

NOVEMBER 1929

WINTER
EDITION

CITIZENS

50¢

Radio Call Book Magazine

and Scientific Digest



SEE PAGE 107

SERVICE - REPAIR - ENGINEERING
POWER AMPLIFICATION - TELEVISION

4 of the 40 Easy Ways to Make \$3⁰⁰ an Hour

In Your Spare Time
in **RADIO**

Below
are a few of
the reports
from those now
cashing in on the
"40 Easy Ways"

THE four plans shown are but a sample of the many ways in which our members are making \$3.00 an hour upwards, spare time and full time, from the day they join the Association. If you want to get into Radio, have a business of your own, make \$50 to \$75 weekly in your spare time, investigate the opportunities offered the inexperienced, ambitious man by the Association.

Our Members Earning Thousands of Dollars Every Week

The Association assists men to cash in on Radio. It makes past experience unnecessary. As a member of the Association you are trained in a quick, easy, practical way to install, service, repair, build and rebuild sets—given sure-fire money-making plans developed by us—helped to secure a position by our Employment Department. You earn while you learn, while you prepare yourself for a big-pay Radio position.

The Association will enable you to buy parts at wholesale, start in business without capital, help you get your share of the \$600,000,000 spent annually for Radio. As a result of the Association, men all over the country are opening stores, increasing their pay, passing licensed operator examinations, landing big-pay positions with Radio makers.



Mail Coupon Today for the FREE HANDBOOK

It is not only chock-full of absorbing information about Radio, but it shows you how easily you can increase your income in your spare time. Mailing the coupon can mean \$50 to \$75 a week more for you.

Radio Training Association of America
4513 Ravenswood Avenue Dept. RCB-11 Chicago, Illinois

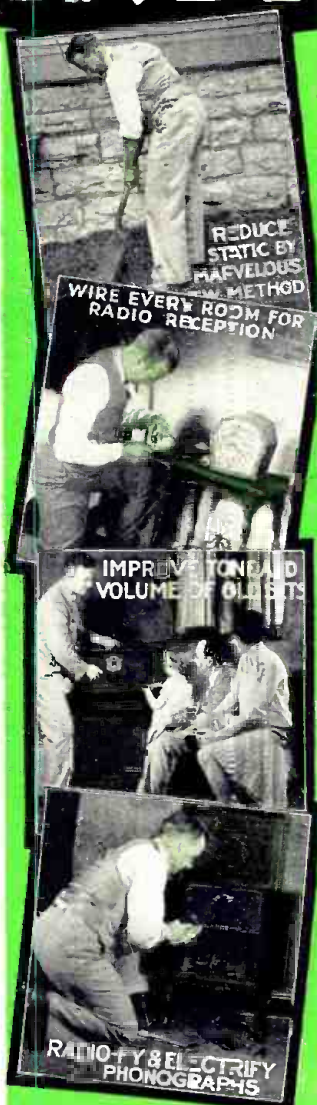

Clears \$3,000.00 Frank J. Deutch, Pa.—"Since joining the Association I have cleared nearly \$3,000.00. It is almost impossible for a young fellow to fail, no matter how little education he has, if he will follow your easy ways of making money."

\$1,100.00 in 6 Weeks J. R. Allen, Calif.—"Have done over \$1,100.00 worth of business in the last 6 weeks. Next month I am going to open up a store of my own. I never knew that money could come so fast and easy."

\$25.00 a Week Spare Time N. J. Friedrich, N. Y.—"I have averaged \$25.00 a week for the last 7 months even though I am not a graduate but just learning."

Training Lands Him Job R. C. Kirk, N. C.—"Your training has been very valuable to me. I landed a job with the big department store out here a few weeks ago because I had my membership card with me. There were a large bunch of applications ahead of me."

ACT NOW If You Wish NO-COST Membership

For a limited time we will give to the ambitious man a No-Cost Membership which need not—should not—cost you a cent. For the sake of making more money now, and having a better position in the future, mail coupon below now. You'll always be glad you did.

Radio Training Association of America
Dept. RCB-11, 4513 Ravenswood Ave., Chicago, Ill.
Gentlemen: Please send me by return mail full details of your Special No-Cost Membership Plan, and also a copy of your Radio Handbook.

Name _____

Address _____

City _____ State _____

2450

SCREEN GRID CHASSIS



FREE
Radio Catalog



A POWERFUL super-sensitive A. C. receiver that answers today's demand for the ultra-modern in a high-grade screen grid receiver. It offers everything you look for that is modern in radio. Nothing has been overlooked to secure outstanding quality—advanced engineering features—or efficient performance.

It is establishing a new standard of perfection in radio design. Incorporating such advanced features as screen grid R. F., power detector, "245" push-pull power audio, dynamic tone quality plus practical scientifically shielded construction, it is blazing a new trail in perfection of circuit design. Its super power assures unusual distance range—its ultra-selectivity adapts it for use in the most congested broadcasting districts. Its remarkable tone quality and tremendous volume win for it the instant admiration of the radio purchaser.

Write Today for this new 196-page catalog full of all the latest in radio showing the new, humless, Screen Grid A. C. all-electric and battery operated sets. Beautiful consoles, dynamic speakers, accessories, parts, kits; in fact, everything in radio and all at rock-bottom wholesale prices. Hundreds of real radio bargains from a Radio House backed by over \$3,000,000 in resources. This book will save you money. Send for it now before you buy anything more in radio supplies!

Use the Coupon

Allied Radio Corporation,
Dept. C-1
711 W. Lake Street, Chicago, Ill.

Please send me your new 1930—196-page radio catalog—which we understand is to be absolutely free.

Name

Address

City State

ALLIED RADIO CORPORATION
711 W. Lake St. Dept. C-1 Chicago, Ill.

Tell 'Em You Saw It in the Citizens Radio Call Book Magazine and Scientific Digest

AERO SHORT-WAVE RECEIVER

GERMANY
FRANCE
HOLLAND
ENGLAND
AUSTRALIA
COSTA RICA
JAVA
NEW-
ZEALAND

SHORT WAVES REACH AROUND THE WORLD



*Complete Factory-Built
All-Wave Receiver*

Aero Overseas Receiver—A-C and D-C Gets Both Short and Long Waves SCREEN GRID

At last—a complete all-wave receiver with which you can get both short and long wave reception.

In the past few years interest in short wave telephony has increased to such an extent that at present there is a demand for a complete short wave receiver. And, in order to make the set even more practical, we have added the long wave feature. Heretofore all short wave adapters in sets which have fallen into the hands of the average layman, have been extremely critical with respect to tuning. In fact, this objection has been so outstanding, as to discourage, rather than encourage, the use of short waves, and as a consequence only experts have been able to get the remarkable performance, long distance and unique programs available on the short waves.

In addition to tuning, there has heretofore been little satisfaction with A-C operation. The hum has been

very objectionable and motorboating has occurred frequently on the higher frequencies.

Bearing these two outstanding faults in mind, Aero Products laboratories, with their intimate knowledge of short-wave requirements, set about to overcome them, and in the *Aero Overseas Four Receiver* has been developed a radio set that gets stations on all waves—both the short as well as the broadcast bands, and with the ease and perfection of the most modern set. A great deal of thought and engineering has made possible in this new receiver, a high degree of sensitivity and unusually easy, simplified tuning. The Aero Overseas Four is comparable to our present-day broadcast sets in operating efficiency and far surpasses any set in its two-fold ability to get everything on the air.

Model A-C, 5 Tubes, including Power Tube—List Price (Without Tubes) \$125.00
Model D-C, 4 Tubes—List Price (Without Tubes) 60.00

AERO PRODUCTS, Inc.

4611 East Ravenswood Avenue Dept. 1089 Chicago, Ill., U. S. A.

AERO PRODUCTS, Inc.,
4611 E. Ravenswood Ave., Dept. 1089,
Chicago, Ill.

Dear Sirs: Send me full particulars of your new all-wave, Aero Overseas Four Receiver for getting stations on broadcast and short waves, also latest information on new developments.

Name.....
Address.....
City..... State.....
State if you are jobber, dealer, set builder or fan:

Enclose remittance of \$60.00 for D-C Model, or \$125.00 for A-C Model, if you order direct from this ad.



Pattern 199 Set Analyzer
 Makes every essential radio service test, including screen grid sets. Simple to operate. Doesn't require a radio engineer to use it. Built to highest standards throughout. Backed by a complete radio data service. Lowest priced, high grade set analyzer.

List Price, \$97.50
 Dealers' Price, \$73.12

Jewell RADIO INSTRUMENTS FOR EVERY SERVICE NEED

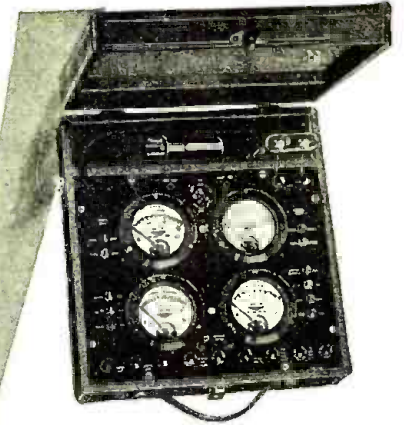

Pattern 409 Set Analyzer
 Has four high grade 3½ inch bakelite case instruments. Gives plate current, plate, filament, and grid voltages simultaneously. Binding posts make all instruments available for independent tests. Backed by the same data service that has made Jewell Pattern 199's famous.

List Price, \$122.50
 Dealers' Price, \$91.88



Pattern 210 Tube Checker

Gives direct reading on all tubes from UX199 to UX250—no mental arithmetic necessary. Adjustable for line variations between 100 and 130 volts. Operates from A. C. service line. Gives individual readings of each plate of double wave rectifier tubes.

List Price, \$65.00
 Dealers' Price, \$48.75

A NEW EDITION of the Jewell booklet, "Instructions for Servicing Radio Receivers," has just been received from the printer. This 64-page booklet contains data on receivers of 38 manufacturers or 139 of the most popular sets.

Furnished Free to Servicemen

This valuable booklet is furnished free to servicemen. Mail the coupon for your copy!

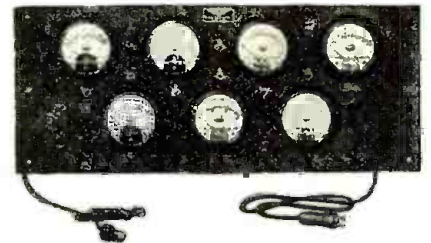

Pattern 581 Test Panel

Provides every requirement for rapid and accurate testing of radio receivers, including screen grid sets. The seven instruments are all large flush type, approximately 5 ins. in diameter.



Jewell Electrical Instrument Company
 1642-G Walnut Street, Chicago

Of course we want your booklet, "Instructions for Servicing Radio Receivers," which contains data on sets of 38 leading radio manufacturers. Please mail without obligation.

Name _____

Address _____

29 YEARS MAKING GOOD INSTRUMENTS

JEWELL

199 Set Analyzer

Tell 'Em You Saw It in the Citizens Radio Call Book Magazine and Scientific Digest

WHAT'S NEWS IN RADIO ?



PILOT Power Packs

No. K-111 for \$16.50
171-A Tubes

Thorough filtration of direct current output, makes hum inaudible. Self-contained rectifier tube. Highly compact. Delivers up to 220 volts. Complete, ready for use. Especially recommended for the A.C. Super-Wasp.

No. K-112 \$19.50
for 245 Tubes

Easily handles two 245's in push-pull plus five or six 227 and 224 types. Variable resistance insures delivery of full rated voltages from the various taps. Delivers up to 300 volts. Ultra-compact. Complete, ready for use.



PILOT Push-Pull AMPLIFIER

[For 245 Tubes]

Here's an amplifier big enough and powerful enough for movie "Talkies" and public address systems. Wherever requirements demand maximum amplification, free from any hint of distortion, this Pilot outfit is recommended. All A, B and C voltages self-contained. Complete in semi-kit form (K-113).

\$39

Hear Foreign Stations with



PILOT SUPER-WASP

BATTERY-OPERATED

\$29.50
Kit K-110 14 to 500 Meters

Short-Wave PLUS Broadcast Reception

Below 200 meters you'll find the real thrill of radio, scores of stations you never knew existed, short-wave programs from European and Australian stations plus all sections of this country and Canada. If you're "fed up" on a hackneyed radio diet, let the Super-Wasp bring you new, exciting adventures. Covers 14 to 500 meter range, making it an ideal combination of Short-wave and Broadcast receiver, utilizing screen-grid tube.

Complete Kit, readily assembled with screw-driver and pliers.

—AND NOW—

An A.C. SUPER-WASP

With this short-wave receiver you hear the world from your electric light socket, made possible by Pilot's specially developed Pilotron 227.

Kit K-115 \$34.50

POWER PACK EXTRA

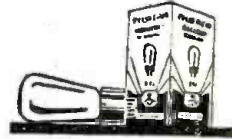

PILOTRONS

Endorsed by Professionals

The original idea behind the Pilotrons was to make a line of radio tubes for a select group of professional radio engineers, custom set-builders, radio researchers, and others whose standards are considerably higher than the general public's. To win endorsement from radio's fustiest folks, Pilotrons had to be outstandingly superior! The constantly mounting demand for Pilotrons required the purchase of an additional tube factory. . . . Now, the general public, learning from radio technicians, insists on Pilotrons, endorsed by professionals.

RADIO'S BIGGEST 50¢ VALUE

brings you membership in Radio International Guild, including the official organ, *Radio Design*—a construction quarterly that sparkles with the latest and greatest radio and short-wave developments! Current issue, together with Membership Pin, Card and Certificate, will be promptly sent on receipt of remittance.

RADIO DESIGN PUB. CO.
103 B'way, Brooklyn, N. Y.

Prices Quoted are for Custom Set-Builders in U. S. A.

Get Pilot's Latest Catalogue from nearest authorized Pilot Dealer or write Direct to Factory.

PILOT RADIO & TUBE CORP.

WORLD'S LARGEST RADIO PARTS PLANT—ESTABLISHED 1908

323 BERRY STREET

BROOKLYN, NEW YORK



TRADE

MARK

Read what BIG money these fellows have made in the RADIO BUSINESS

\$375 One Month Spare Time



"Recently I made \$375 in one month in my spare time installing, servicing, selling Radio sets. And, not so long ago, I earned enough in one week to pay for my course."
EARLE CUMMINGS,
 18 Webster St., Haverhill, Mass.

\$1597 In Five Months



"The N. R. I. is the best Radio school in the U. S. A. I have made \$1597 in five months. I shall always tell my friends that I owe my success to you."
HENRY J. NICKS, JR.,
 302 Safford Ave.,
 Tarpon Springs, Fla.

\$1164 Spare Time Profits



"Look at what I have made since I enrolled, \$1,164—money I would not have had otherwise. I am certainly glad I took up Radio with N. R. I. I am more than satisfied."
HENRY R. HEIKKINEN,
 123 W. Erie St., Chicago, Ill

Over \$1000 In Four Months



"My opinion of the N. R. I. course is that it is the best to be had at any price. When I enrolled I didn't know a condenser from a transformer, but from December to April I made well over \$1000 and I only worked in the mornings."
AL JOHNSON,
 1109 Shelby St., Sandusky, Ohio.

I will show you too how to start a spare time or full time Radio Business of Your Own without capital



Radio's amazing growth is making many big jobs. The world-wide use of receiving sets and the lack of trained men to sell, install and service them has opened many splendid chances for spare time and full time businesses.

Ever so often a new business is started in this country. We have seen how the growth of the automobile industry, electricity and others made men rich. Now Radio is doing the same thing. Its future has already made many men rich and will make more wealthy in the future. Surely you are not going to pass up this wonderful chance for success.

More Trained Radio Men Needed

A famous Radio expert says there are four good jobs for every man trained to hold them. Radio has grown so fast that it simply has not got the number of trained men it needs. Every year there are hundreds of fine jobs among its many branches such as broadcasting stations, Radio factories, jobbers, dealers, on board ship, commercial land stations, and many others. Many of the six to ten million receiving sets now in use are only 25% to 40% efficient. This has made your big chance for a spare time or full time business of your own selling, installing, repairing sets.

So Many Opportunities You Can Make Extra Money While Learning

Many of our students make \$10, \$20, \$30 a week extra while learning. I'll show you the plans and ideas that have proved successful for them—show you

how to begin making extra money shortly after you enroll. G. W. Page, 1807-21st Ave., S., Nashville, Tenn., made \$935 in his spare time while taking my course.

I Give You Practical Radio Experience With My Course

My course is not just theory. My method gives you practical Radio experience—you learn the "how" and "why" of practically every type of Radio set made. This gives you confidence to tackle any Radio problems and shows up in your pay envelope too.

You can build 100 circuits with the Six Big Outfits of Radio parts I give you. The pictures here show only three of them. My book explains my method of giving practical training at home. Get your copy!

I Will Train You At Home In Your Spare Time

I bring my training to you. Hold your job. Give me only part of your spare time. You don't have to be a college or high school graduate. Many of my graduates now making big money in Radio didn't even finish the grades. Boys 14, 15 years old and men up to 60 have finished my course successfully.

You Must Be Satisfied

I will give you a written agreement the day you enroll to refund your money if you are not satisfied with the lessons and instruction service when you complete the course. You are the only judge. The resources of the N. R. I. Pioneer and Largest Home-Study Radio school in the world stand back of this agreement.

Get My Book

Find out what Radio offers you. My 64-page book, "Rich Rewards in Radio" points out the money making opportunities the growth of Radio has made for you. Clip the coupon. Send it to me. You won't be obligated in the least.

Address

**J. E. Smith, Pres.
 Dept. 9YD**

**National Radio Institute
 Washington, D. C.**

This Book points out what Radio offers you. Get a copy!



This coupon is good for a FREE copy of my Valuable Book. Mail it NOW!

J. E. Smith,
 President,
 Dept. 9YD
 National Radio Institute, Washington, D. C.

Dear Mr. Smith: Send me your book. I want to know more about the opportunities in Radio and your practical method of teaching at home in spare time. This request does not obligate me to enroll and I understand no agent will call on me.

Name..... Age.....
 Address.....
 City..... State.....

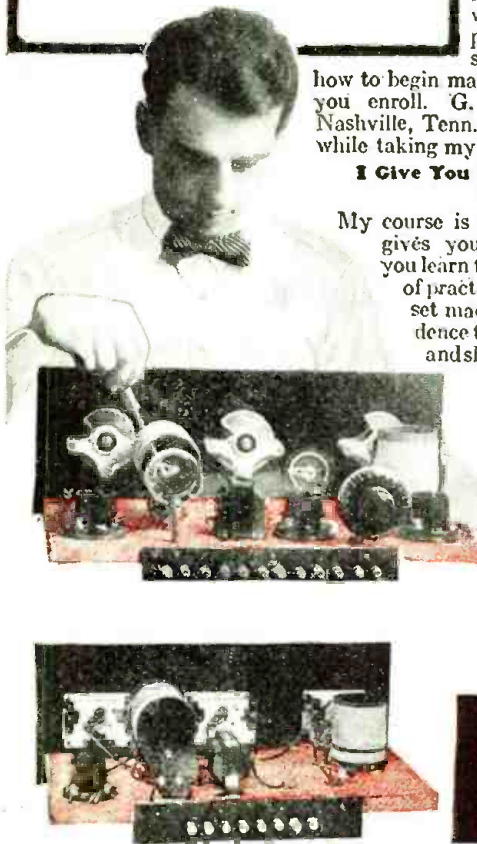

Tell 'Em You Saw It in the Citizens Radio Call Book Magazine and Scientific Digest

BY AUTHORITY OF THE UNITED STATES GOVERNMENT

THERE IS
ONLY ONE
DYNAMIC
SPEAKER



MAGNAVOX

THE ORIGINAL

WITH THE CAN'T-BE-COPIED

REALISM

The U. S. Patent Office has granted to the Magnavox Company exclusive use of the word "DYNAMIC" in connection with radio loud speakers.

Patents may be infringed, trademarks may be borrowed, but performance quality cannot be

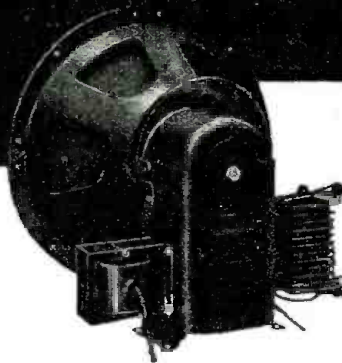

Models 401, 403 and 405
12¼" high, 12" wide, 8¼" deep
10½" cone

copied. The making of a dynamic speaker is an art that was started by the Magnavox Company in 1911 and carried on since that time.

THE MAGNAVOX COMPANY

Factory and Pacific Sales: OAKLAND, CALIF.
Factory and Sales East of the Rockies: CHICAGO, ILL.

Tell 'Em You Saw It in the Citizens Radio Call Book Magazine and Scientific Digest



SCOTT A-C SCREEN GRID 10

Screen Grid Performance Plus!

Eighteen months ago Scott announced a receiver using screen-grid tubes. This model was the result of nearly six months' work in the laboratory. The new 1930 Scott A-C Screen-Grid 10 is therefore the result of two years' actual experience with screen-grid receivers. The performance of this new model is so far in advance of any other receiver on the market today, that there is no standard with which to compare it. It uses ten tubes, three of which are screen-grid. The micro-matched Scott shielded intermediate transformers secure almost unbelievable amplification out of each screen-grid tube.

Unlimited Distance Range

The tremendous power of the new Scott A-C Screen-Grid 10 gives distance reception undreamed of a year ago. Stations come in with more volume than is ever desired. Every station seems like a local. Proof of this is the verification of station 2ME of Sydney, Australia, on March 12th of this year right from the center of Chicago.

Keen Selectivity

There is a different station on every point of the dial. By turning the single drum dial just a degree the most powerful local vanishes. Then, as you turn to the next point, some far off station perhaps a thousand, two thousand, or three thousand miles away thunders in. Another turn and it is gone. Never before has such perfect, sharp, yet easily handled selectivity been built into a receiver. Scott has outdone Scott! The possibilities of this new set actually dwarf the world's record established on the original Scott World's Record Receiver. Remember what it did—brought in 117 different programs from stations, the

closest of which was 6,000 miles to as far away as 8,375 miles, during a 13 week test period. It has challenged the entire radio industry to equal its performance—and none have answered it.

Absolutely Humless

The filter system used in this new Scott Custom-Built A-C Screen Grid 10 is so perfect that every trace of A. C. hum has been eliminated. Bend down, put your ear right up against the speaker, and you find it difficult to believe the receiver is switched on. The downright realism of the tone amazes you, when you hear it with every trace of A.C. hum eliminated.



Custom Set Builders and Dealers

If you are interested in selling the one receiver which has no competition, and at the same time enjoy an absolutely protected market, check the coupon and mail at once.

New Scott Short Wave Converter Tunes as Easily as a Broadcast Receiver

Here is a new kind of short wave converter. Gone forever, is that tricky, critical tuning, formerly required to tune a short wave receiver. A new feature we have developed in the laboratory spreads the stations in each band to what amounts to a tuning dial *twenty inches in diameter*. It brings in voice and code alike with perfect clarity. Listen to stations in England, Germany, France, South

Africa, Australia and New Zealand. You hear them all from 14 to 80 meters. Here is a real *international* receiver. Order a short wave converter when you order your Scott A-C Screen Grid 10—price \$32.50.

MAIL COUPON

The coupon from this announcement will bring you full particulars of the New Scott A-C Screen Grid 10—also pictures and descriptions of the many gorgeous console cabinets especially built for this receiver. Clip the coupon—mail it now—today!

SCOTT TRANSFORMER CO., **Clip Now!**
4450 Ravenswood Ave.,
Chicago, Ill.

CRCB10

- Send me full particulars of the New Scott A-C Shield Grid 10.
- Send me your franchised Set Builders Proposition.

NAME

ADDRESS

TOWN STATE

SCOTT TRANSFORMER CO., 4450 Ravenswood Ave., CHICAGO., ILL.

Tell 'Em You Saw It in the Citizens Radio Call Book Magazine and Scientific Digest

Citizens Radio Call Book Magazine

AND SCIENTIFIC DIGEST

Registered in U. S. Patent Office

Established 1921

Executive Offices:

508 So. Dearborn St., Chicago, Ill.

Member Audit Bureau of Circulations

C. O. STIMPSON, President
D. H. BELL, Secretary-Treasurer
H. ANHEISER, Assistant Treasurer

F. A. HILL, Managing Editor
RICHARD K. PEW, Technical Editor
C. B. BENSON, Advertising Manager
M. R. HARRIS, Circulation Manager

NOVEMBER, 1929

Published January, March, September, November

Vol. 10, No. 4

CONTENTS THIS ISSUE

Roster of Columbia and National Broadcasting Chain Stations.....	10
Latest Revised U. S. Broadcast Station List.....	10-30
Consolidated U. S. Broadcast Stations.....	32
U. S. Broadcast Stations by Frequency.....	34
U. S. Broadcast Stations by States.....	36
Short Wave Relay Broadcast Stations.....	38
Visual Broadcast Stations.....	38
Foreign Broadcast Stations.....	38
Foreign Broadcast Stations (Continued).....	39
Map of U. S.....	40, 41
Mileage Chart of Air Line Distances.....	42, 43
Handy Log Chart.....	44
Ampere Andy's Assistors.....	46, 47, 48
Four Screen Grid Stages Used in National MB-29 Receiver.....	49, 50
Hammarlund Custom Built Screen Grid Band Filter Receiver.....	51, 52
S-M 712 Band Selector Tuner Now Goes in Class With Supers.....	53, 54
Pre-selection Tuning Used in Nelson Model N-30 A. C. Receiver.....	55, 56
Aero Overseas Short Wave A. C. Receiver.....	57, 58
Scott Short Wave Converter.....	59, 60
Latest Amplifier Design with 245 Tubes Seen in S-M 677 Unit.....	61, 62
Pilot Super Wasp Short Wave Receiver.....	63, 64
Mississippi Valley Has Two Models of A. C. Screen Grid Supers.....	65, 66
Diathermy Apparatus May Interfere Over a Broad Reception Area.....	67, 68
RADIO ENGINEERING DEPARTMENT:	
Power Detection Symposium, Contributed by	
Byron B. Minnium, Chief Research Engineer, Stewart-Warner Corp.....	69
McMurdo Silver, President, Silver-Marshall, Inc.....	70
A. Crossley, Chief Engineer, Howard Radio Co.....	70
Ray H. Manson, Vice-President and Chief Engineer, Stromberg-Carlson Telephone Mfg. Co.....	70
E. K. Oxner, Chief Engineer, High Frequency Laboratories.....	70
F. J. Marco, Chief Engineer, Audiola Radio Co.....	70
R. H. Langley, Director of Engineering, Crosley Radio Co.....	71
Production Testing of Audio Frequency Amplifiers.....	71, 72
By Arthur E. Thiessen, Engineering Dept., General Radio Co.....	73, 74, 75
Making a Capacity Bridge.....	73, 74, 75
By R. K. Pew, Technical Editor	
A Break-Down Test for Leaky Condensers.....	76
By R. O. Lewis, Engineering Dept., Grigsby-Grunow Co.....	76
POWER AMPLIFICATION SECTION.....	77, 78, 79, 80
SERVICE AND REPAIR.....	81, 82, 83, 84, 85, 86
SERVICE AND REPAIR SCHEMATICS	
Grebe Synchrophase 7 a. c. Set.....	87
Stromberg-Carlson 635-636 Receiver.....	88
Federal Model H a. c. Receiver.....	89
Freed-Eisemann NR-80 and Supply.....	90
Model 28 and 29 Bosch Receivers.....	91
The Amrad Model 70 a. c. Receiver.....	92
Brunswick No. 3KRO with Panatropes.....	93
A. C. Dayton Navigator Receiver.....	94
Sonora DeLuxe Highboy Model Receiver 5-R.....	95
Philco Receiver Models 86 and 82.....	96
Citizens Three Tube Receiver Uses 224 Tube as Power Detector.....	97, 98
Norden-Hauck Announces New Model Admiralty Super 10 Radio.....	99
Changing Electrical Energy into Sound Is Interesting Step.....	100
PRACTICAL TELEVISION.....	101, 102
A B C OF RADIO.....	103
Recording Equipment for Talkies Uses Many Radio Principles.....	104, 105, 106
Radio-Telephone Equipment Is Used for Railway Communication.....	107, 108
Improved Leutz Seven Seas Console with Phonograph.....	109
New Beam Wireless Installation.....	110
Tones of Big Ben Reproduced Synthetically by Radio.....	111
Baird Tele-Talkie Transmitter Recently Demonstrated.....	112
There Is More in a Storage Battery Than You Might Think.....	113, 114, 115
"Please Stand By for Station Announcement".....	116, 117, 118
With the Accessory and Parts Manufacturers.....	119
Blue Print Page.....	154
Index to Advertisers.....	158

In This Issue

LATEST data on the better known kit receivers is a feature of this present issue, giving readers a wonderful opportunity to find out the trend in modern kit design.

An enlarged Radio Engineering Department will be noticed. In it several of the well known engineers have contributed to a symposium on the use of a 227 or 224 in power detection circuits. Altogether there are eight pages brim full of original material by well known authors. In the Service and Repair Section we give a few of the tube characteristic charts covering a number of the present-day tubes, while further information along this line will be found in the January issue. As usual, there are ten schematics of as many factory built receivers.

Changes in the broadcast allocations made by the Commission a few days before going to press have been taken care of in this present issue, so that the U. S. broadcast station list together with the foreign broadcast station list is the last word in accuracy.

In the Power Amplification Section will be found a number of photographs of installations made by one of our readers, while a very interesting story of the methods by which machinery sounds were produced in David Belasco's latest play is related. We dare say that those who saw the play have often wondered how the spectacle was staged and this article illustrates how it was done.

Photographs of the new type of scanning disc used by one of the television pioneers are given in the Television section. This subject is again beginning to attract some attention, principally because a number of stations are now prepared to broadcast images by radio.

The Editor.

Copyright, 1929, by Citizens Radio Service Bureau, Incorporated, Publishers. Requests for permission to reprint any articles or other matter contained herein must be made in writing to the executive offices.

Citizens Radio Call Book Magazine is published four times a year and is on sale approximately the first of January, March, September and November. Subscription price \$1.75 per year in U. S. A. Canada and Foreign \$2.00 per year, payable in advance. Single copies 50 cents. Remit by check, draft or P. O. order. No foreign stamps or coins accepted. Mail subscriptions to 508 So. Dearborn Street, Chicago. We will not be responsible for cash sent for subscriptions unless registered.

Advertising Representatives:

Chicago—A. B. Mills, 508 So. Dearborn St. Wabash 1901.

New York—(Branch Office)—154 W. 42nd St. Room 1125. Wisconsin 5681.

Entered as second class matter November 15, 1928, at the Postoffice at Chicago, Illinois, under the act of March 3, 1879

Final Tests ... to assure *perfection*

Naturally — every TRIAD Tube is constantly, rigorously tested throughout the entire manufacturing process — a special test follows every individual operation. Yet TRIAD does *more than that!* When completed, each TRIAD Tube is subjected to nine *additional* and *final* tests for vital characteristics — tests so stringent that nothing short of absolute perfection can survive them! This infinite care in manufacture has won for TRIADS their reputation for superior quality — and has made possible that guarantee that goes with every TRIAD Tube — a minimum of six months' satisfactory service or a proper adjustment. You can rely on TRIADS — the tubes backed by an actual Insurance Certificate!

Ask your nearest dealer for TRIADS —
the *insured* radio tubes!

TRIAD MFG. CO., Inc., Pawtucket, R. I.

Tune in on the TRIADORS every FRIDAY evening, 8 to 8:30 Eastern Standard Time, over WJZ and associated NBC Stations.

TRIAD

INSURED

RADIO TUBES

Ask for the tube in the black and yellow triangular box.



FINAL TESTS

Below are listed the nine *final* tests for vital characteristics to which every TRIAD Tube is subjected.

- 1 Gas
- 2 Emission
- 3 Filament Current
- 4 Plate Current
- 5 Oscillation
- 6 Grid Voltage
- 7 Mutual Conductance
- 8 Plate Impedance
- 9 Amplification Constant

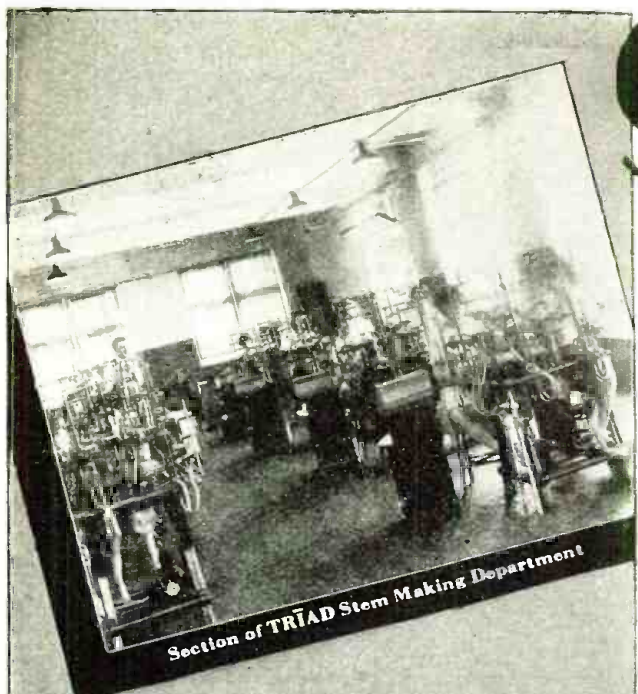

Section of TRIAD Stem Making Department

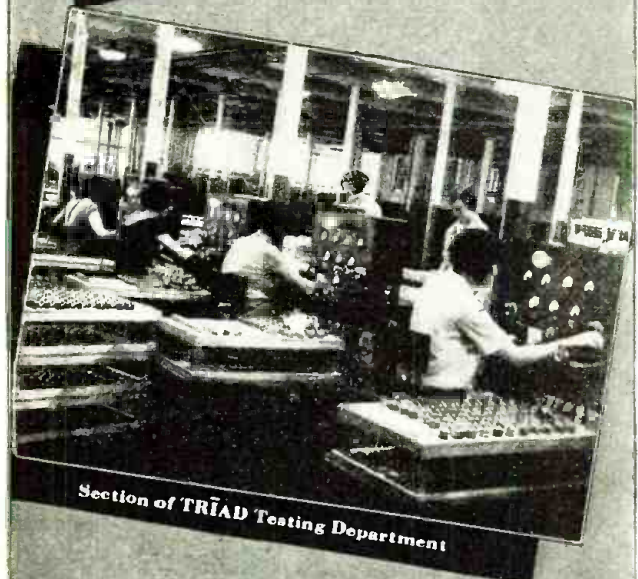

Section of TRIAD Testing Department

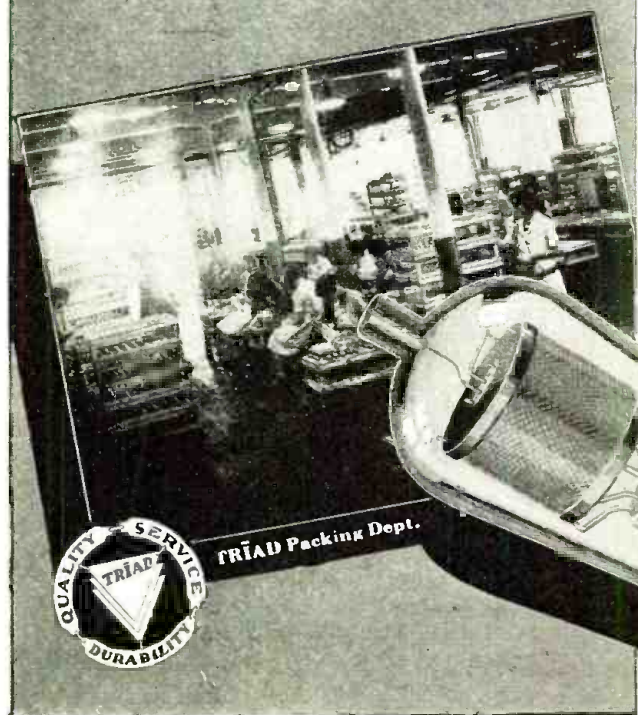

TRIAD Packing Dept.



Tell 'Em You Saw It in the Citizens Radio Call Book Magazine and Scientific Digest

American Broadcasting Stations

Station assignments shown in the following pages were made by the Federal Radio Commission. This list is revised from issue to issue and is therefore up-to-the-minute. Initials such as E, C, M, and P denote Eastern, Central, Mountain and Pacific time.

Stations associated with the National Broadcasting System: WEAJ, WJZ, WEEI, WBZA, WBZ, WTIC, WJAR, WTAG, WCSH, WFI, WLIT, WRC, WBAL, WGY, WGR, WHAM, WCAE, KDKA, WTAM-WEAR, WFJC, WWJ, WJR, WLW-WSAI, WGN-WLIB, WENR, WLS, KYW-KFKX, WCFL, WIBO, KSD, KWK, WOC, WHO, WOW, WDAF, WREN, KSTP, WTMJ, KOA, WHAS, WSM, WMC, WSB, WBT, WPTF, WAPI, WSMB, KVOO, WFAA, KPRC, WOAI, WBAP, WRVA, WJAX, WIOD, KPO, KGO, KFI, KGW, KOMO, KHQ, WEBC, KSL, WKY, KTHS, KFAB, WCKY.

Stations associated with the Columbia Broadcasting System: WADC, WCAO, WNAC, WMAK, WKBW, WMAQ, WBBM, WKRC, WHK, WGHP, WOWO, KMBC, WABC, W2XE, WLBW, KOIL, WCAU, WFAN, WJAS, WEAN, KMOX, WFBL, WSPD, WMAL, WHP, WHEC, WFBM, WAIU, WKBN, CFRB, CKGW, CKAC, CJGC, WWNC, WTAR, WDBJ, WBRC, WDOD, WREC, WLAC, WDSU, KRLD, KLRA, KFJF, KTSB, WIBW, KFH, WISN, WCCO, WRHM, KLZ, KDYL, KHJ, KFRC, KOIN, KVI, KFPY.

KCRC

1370 kc. Enid, Okla., Champlin Refining Co., 100 w. C.

KDB

1500 kc. Santa Barbara, Calif., Santa Barbara Broadcasting Co., 100 w. P.

KDKA

980 kc. East Pittsburgh, Pa., Westinghouse E. & M. Co., 59,000 w. E.

KDLR

1210 kc. Devils Lake, N. D., Radio Electric Co., 100 w.

KDYL

1290 kc. Salt Lake City, Utah, Intermountain Broadcasting Corp., 1000 w. M. "On the Air. Goes Everywhere."

KEJK

1170 kc. Beverly Hills, Calif., R. S. MacMillan, 500 w. P.

KELW

780 kc. Burbank, Calif., Earl L. White, 500 w. P. "The White Spot of the San Fernando Valley."

KEX

1180 kc. Portland, Ore., Western Broadcasting Co., 5000 w. P. "A Public Service Necessity."

KFAB

770 kc. Lincoln, Neb., Nebraska Buick Automobile Co., 5000 w. C. "Home, Sweet Home."

KFAD

620 kc. Phoenix, Ariz., Electric Equipment Co., 500 w. M. "Phoenix, Where Winter Never Comes."

KFBB

1360 kc. Great Falls, Mont., Buttrey Broadcast, Inc., 500 w. M.

KFBK

1310 kc. Sacramento, Calif., James McClatchy Co., 100 w. P.

KFBL

1370 kc. Everett, Wash., Leese Bros., 50 w. P. "The Voice of Puget Sound."

KFDM

560 kc. Beaumont, Tex., Magnolia Petroleum Co., 500 w. C. "Kall for Dependable Magnolene."

KDFN

1210 kc. Casper, Wyo. D. L. Hathaway, 100 w. P.

KFDY

550 kc. Brookings, S. D., State College, 500 w. C.

KFEL

940 kc. Denver, Col., Eugene P. O'Fallon, Inc., 250 w. M. "The Argonaut Station."

KFEQ

560 kc. St. Joseph, Mo., Scroggin & Co., 2500 w. C.

KFGQ

1310 kc. Boone, Iowa, Boone Biblical College, 100 w. C.

KFH

1300 kc. Wichita, Kan., Hotel Lassen, 500 w. C. "Kansas' Finest Hotel, in the Very Heart of God's Country."

KFHA

1200 kc. Gunnison, Colo., Western St. College of Colorado, 50 w.

KFI

640 kc. Los Angeles, Calif., Earl C. Anthony, Inc., 5000 w. P. "National Institution."

KFIF

1420 kc. Portland, Ore., Benson Polytechnic School, 100 w. P.

KFIO

1230 kc. Spokane, Wash., Spokane Broadcasting Corp., 100 w. day, P.

KFIZ

1420 kc. Fond du Lac, Wis., Reporter Printing Co., 100 w. C.

KFJB

1200 kc. Marshalltown, Iowa, Marshall Electric Co., 100 w. C. "Marshalltown, the Heart of Iowa."

KFJF

1470 kc. Oklahoma City, Okla., National Radio Mfg. Co., 5000 w. C. "Radio Headquarters of Oklahoma."

KFJI

1370 kc. Astoria, Ore., KFJI Broadcasters, Inc., 100 w. P.

KFJM

1370 kc. Grand Forks, N. D., University of North Dakota, 100 w. C.

KFJR

1300 kc. Portland, Ore., Ashley C. Dixon & Son, 500 w. P.

KFJY

1310 kc. Ft. Dodge, Iowa, C. S. Tunwal, 100 w. C.

KFJZ

1370 kc. Ft. Worth, Texas, Henry Clay Meacham, 100 w. C.

KFKA

880 kc. Greeley, Colo., Colorado State Teachers College, 500 w. M. Shared.

KFKB

1050 kc. Milford, Kan., J. R. Brinkley, M. D., 5000 w. C. "The Sunshine Station in the Heart of the Nation."

KFKU

1220 kc. Lawrence, Kan., University of Kansas, 1000 w. C. "Up at Lawrence on the Kaw."

KFKX

See under KYW.

KFKZ

1200 kc. Kirksville, Mo., Northeast Missouri State Teachers College, 15 w. C. "Kirksville, the Home of Osteopathy."

KFLV

1410 kc. Rockford Ill., A. T. Frykman, 100 w. C.

KFLX

1370 kc. Galveston, Texas, Geo. Roy Clough, 100 w. C.

Men Who COMPARE Voltage Controls Choose ELECTRADS

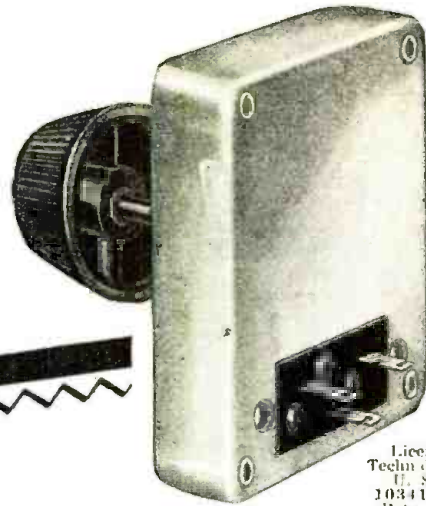

Licensed by Technodyne Corp. U. S. Pats. 1034103-04 & Pats. Pending

ELECTRAD Super-TONATROL

A long-lasting volume control for use with the heavy currents of modern receiver design. Will easily dissipate 5 watts without varying in resistance.

New type resistance element is fused to the surface of an enameled metal plate. Practically all-metal construction promotes rapid heat dissipation.



Pure silver floating contact of new design provides a remarkably smooth action which improves with use owing to a microscopic deposit of silver on the resistance element. Firmly riveted for strength. Bakelite insulation. 7 types for every volume control purpose, including electrical phonograph pickups. List Prices, \$2.40 to \$3.50.

RADIO engineers, manufacturers and custom-set builders **KNOW** that the effective performance of their product depends upon the reliability of the parts they use. They *compare* before making their selection. Quality performance—longer life—most advanced design and construction—all go to make **ELECTRADS** first choice of men who **KNOW** resistances and voltage controls.

Yet, scientifically controlled mass production enables **ELECTRAD** products to be sold at prices which appeal to the pocket-book.

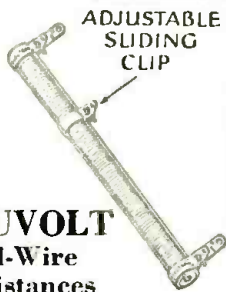

TRUVOLT All-Wire Resistances

The ideal resistance for eliminators and power packs owing to its constant value and long life. Patented winding—directly air-cooled. Nichrome resistance wire is wound around an asbestos covered copper core—then around a grooved fire-clay tube. Accurately rated. Exclusive sliding clip for quick adjustments.

TRUVOLT VARIABLES have same distinctive construction plus knob adjustment. Last longer owing to endwise travel of contact over wire. Greatly simplify eliminator design. All usual resistance values and wattage ratings.

TRUVOLT Variables

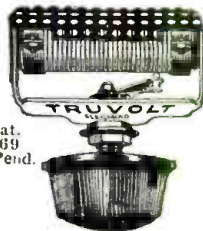

U. S. Pat. 1676869 & Pats. Pend.

The same distinctive air-cooled winding as **TRUVOLT** fixed resistances, plus a control knob for fine adjustments. One-hole mounting. A unique feature of the **TRUVOLT** Variable is that, owing to the patented **TRUVOLT** winding, the contact travels *endwise* over the wire. Lasts longer—operates more smoothly. Sturdy frame, with perforated ventilating shield which aids heat dissipation. Greatly simplifies eliminator design. 22 stock sizes—\$2.50 each.

TRUVOLT Divider

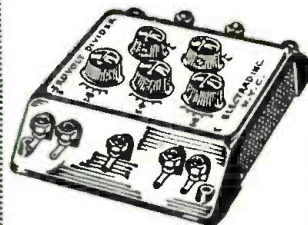

U. S. Pat. 1676869 & Pats. Pend.

The universal voltage divider which eliminates guess-work from voltage calculations. Resistance bank containing five calibrated knobs for instant adjustment of B and C voltages from any type of eliminator. No calculations necessary. Handsome molded Bakelite case—compact—easily mounted. A great time-saver for the radio experimenter. \$10.00.

[ELECTRAD manufactures a complete line of resistance units and voltage controls for all radio and power supply requirements, including Television.]

175 Varick St., New York, N.Y.

ELECTRAD INC.

ELECTRAD, INC., Dept. CH11, 175 Varick Street, New York, N. Y.
 Please send complete information on products checked
 Super-TONATROL ROYALTY All Products
 TRUVOLTS PHASATROL
 Name _____
 Address _____

Tell 'Em You Saw It in the Citizens Radio Call Book Magazine and Scientific Digest

KFMX

1250 kc, Northfield, Minn., Carleton College, 1000 w, C.

KFNF

890 kc, Shenandoah, Iowa, Henry Field Seed Co., 500 w, C. "Known for Neighborly Folks."

KFOR

1210 kc, Lincoln, Nebr., Howard A. Shuman, 100 w, C.

KFOX

1250 kc, Long Beach, Calif., Nichols & Warriner, Inc., 1000 w, P. "Where Your Ship Comes In."

KFPL

1310 kc, Dublin, Texas, C. C. Baxter, 100 w, C. "Baxter's Place."

KFPM

1310 kc, Greenville, Texas, The New Furniture Co., 15 w, C. "Biggest Little Ten Watts on the Air."

KFPW

1340 kc, Siloam Springs, Ark., Rev. Lannie W. Stewart, 50 w, C.

KFPY

1340 kc, Spokane, Wash., Symons Investment Co., 500 w, P.

KFQA

See under KMOX.

KFQU

1420 kc, Holy City, Calif., W. E. Riker, 100 w, P.

KFQW

1420 kc, Seattle, Wash., KFQW, Inc., 100 w, P. "Gateway to Alaska and the Orient."

KFQZ

860 kc, Hollywood, Calif., Taft Radio & Broadcasting Co., Inc., 250 w, P.

KFRC

610 kc, San Francisco, Calif., Don Lee, Inc., 1000 w, P.

KFRU

630 kc, Columbia, Mo., Stephens College, 500 w, C. "Where Friendliness Is Broadcast Daily."

KFSD

600 kc, San Diego, Calif., Airfan Radio Corp., 500 w, P.

KFSG

1120 kc, Los Angeles, Calif., Echo Park Evan. Assn., 500 w, P. "The Church of the Air."

KFUL

1290 kc, Galveston, Texas, W. H. Ford, 1000 w, C. "The City of Perpetual Sunshine."

KFUM

1270 kc, Colorado Springs, Colo., W. D. Corley, 1000 w, M. "Known for Unsurpassed Mountain Scenery."

KFUO

550 kc, St. Louis, Mo., Concordia Theological Seminary, 500 w, C. "The Gospel Voice."

KFUP

1310 kc, Denver, Colo., Fitzsimmons General Hospital, 100 w, M.

KFVD

710 kc, Culver City, Calif., Los Angeles Broadcasting Co., 250 w, P.

KFVS

1210 kc, Cape Girardeau, Mo., Hirsch Battery & Radio Co., 100 w, C. "The City of Opportunity."

KFWB

950 kc, Hollywood, Calif., Warner Bros. Broadcasting, 1000 w, P.

KFWF

1200 kc, St. Louis, Mo., St. Louis Truth Center, Inc., 100 w.

KFWI

930 kc, San Francisco, Calif., Radio Entertainments, Inc., 500 w, P.

KFWM

930 kc, Oakland, Calif., Oakland Educational Society, 500 w, P. "The Most Good to the Most People."

KFXD

1420 kc, Jerome, Idaho, Service Radio Co., 50 w, M.

KFXF

940 kc, Denver, Colo., Pikes Peak Broadcasting Co., 250 w, M. "The Voice of Denver."

KFXJ

1310 kc, Edgewater, Colo., R. G. Howell, 50 w, M. "America's Scenic Center."

KFXM

1200 kc, Ontario, Calif., J. R. Fouche, 100 w, P. "The Voice of the Orange Empire."

KFXR

1310 kc, Oklahoma City, Okla., Exchange Avenue Baptist Church, 100 w, C.

KFXY

1420 kc, Flagstaff, Ariz., Mary M. Costigan, 100 w, M.

KFYO

1420 kc, Abilene, Texas, T. E. Kirksey, 100 w, C. "Breckenridge, the Dynamo of West Texas."

KFYR

550 kc, Bismarck, N. D., Hoskins-Meyer, 500 w, C.

KGA

1470 kc, Spokane, Wash., Northwest Radio Service Co., 5000 w, P.

KGAR

1370 kc, Tucson, Ariz., Tucson Motor Service Co., 100 w, M. "Way Out on the Desert."

KGB

1360 kc, San Diego, Calif., Pickwick Broadcasting Corp., 250 w, P. "Music for the Sick."

KGBU

900 kc, Ketchikan, Alaska, Alaska Radio & Service Co., 500 w, Shared.

KGBX

1370 kc, St. Joseph, Mo., Foster-Hall Tire Co., 100 w.

KGBZ

930 kc, York, Nebr., Geo. R. Miller, 500 w, C. "The Swine and Poultry Station."

KGCA

1270 kc, Decorah, Iowa, Chas. W. Greenley, 50 w, C. Shared.

KGCI

1370 kc, San Antonio, Texas, Liberto Radio Sales, 100 w, C. "Radio Sam at San Antonio."

KGCR

1210 kc, Watertown, S. D., Cutler's Radio Broadcasting Service, Inc., 100 w.

KGCU

1200 kc, Mandan, N. D., Mandan Radio Association, 100 w, M. "The Voice of the West."

KGCC

1310 kc, Wolf Point, Mont., First State Bank of Vida, 10 w, M.

KGDA

1370 kc, Dell Rapids, S. D., Home Auto Co., 50 w.

KGDE

1200 kc, Fergus Falls, Minn., Jaren Drug Co., 50 w, C.

KGDM

1100 kc, Stockton, Calif., E. F. Pepper, 50 w.

KGDR

1500 kc, San Antonio, Texas, Milan Radio Co., Inc., 100 w, C.

KGDY

1200 kc, Oldham, S. Dak., J. Albert Loesch, 15 w, C.

KGEF

1300 kc, Los Angeles, Calif., Trinity Methodist Church, 1000 w, P.

KGEK

1200 kc, Yuma, Colo., Beehler Elec. Equip. Co., 50 w, M. Shared.

KGER

1370 kc, Long Beach, Calif., C. Marwin Dohyns, 100 w, P. "The Service Club of the Air."

KGEW

1200 kc, Ft. Morgan, Colo., City of Ft. Morgan, 100 w, P.

KGEZ

1310 kc, Kalispell, Mont., Chamber of Commerce, 100 w, M. "Located in the Switzerland of America—The Beautiful Flathead Valley."

KGFF

1420 kc, Alva, Okla., D. R. Wallace, 100 w, C.

KGFG

1370 kc, Oklahoma City, Okla., Faith Tabernacle Assn., 100 w, C. "The Whole Gospel to the Whole World."



This Book Has Shown 7143 Men How to Make MORE MONEY

Chock
Full of
Money-Making
Facts!

AND it will do the same for you! All I ask is a chance to prove it.

If you are the sort of a fellow who is content to grind all your life for poor pay you'll not be interested in what it has to tell you.

But if you are looking for an honest-to-goodness opportunity to earn more money — if you look forward to having a business of your own — if you really have **THE WILL TO WIN**—

Then you owe it to yourself to send for this amazing book.

You have never read anything like this straight-from-the-shoulder, intensely human story. Read it and find out how 7143 men—average men, just like yourself—men with the same problems you

are now up against—read how these men let me help them accomplish exactly what you would like to do. Your spare time a few evenings a week is worth money, *real* money. I am ready to pay you for it—from \$25 to \$60 a week. And you can keep your present job.

I don't ask you to take my word for it. I'll give you the names of men who are doing it every day. My plan is simple—thoroughly tested and proven. The facts are there in the book for you to read and judge for yourself.

Investigate. Send for this book and get the whole wealth-bringing story. Convince yourself that I can help you make extra money. Start now by mailing the coupon.

Be sure to give your county.
—J. Matheson Bell, *Pres.*



See for yourself the record of a man who has made \$10,900 out of Ozarka. And another who made \$1750 last year; another \$1645; another \$1848; and so they go—\$1212, \$1708, \$1028 for last year's work. Hundreds of them with their names. Make me prove that what they have done, you can do.

OZARKA, INCORPORATED
120 Austin Avenue, Chicago, Illinois

MAIL THIS COUPON NOW
Gentlemen—I want to know how I can make more money. Please send me a copy of your book, "The Will To Win."
Name.....
Address.....
County.....

Tell 'Em You Saw It in the Citizens Radio Call Book Magazine and Scientific Digest

KGFI

1500 kc. Corpus Christi, Texas. Eagle Broadcasting Co., 100 w, C. "The Voice of West Texas."

KGFI

1420 kc. Los Angeles, Calif., Ben S. McGlashan. 100 w, P, "Keeps Good Folks Joyful."

KGFK

1200 kc. Hallock, Minn., R. W. Lautzenheiser, 50 w, C.

KGFL

1370 kc. Raton, N. Mex., Hubbard & Murphy, 50 w, M.

KGFW

1420 kc, Ravenna, Neb., Otto F. Sothman, 50 w, C.

KGFX

580 kc, Pierre, S. D., Dana McNeil, 200 w, C.

KGGC

1420 kc, San Francisco, Calif., Golden Gate Broadcasting Co., 50 w, P.

KGGF

1010 kc, Ficher, Okla., D. L. Connell, M.D., 500 w, C.

KGGM

1370 kc, Albuquerque, N. Mex., New Mexico Broadcasting Co., 100 w, C.

KGHF

1320 kc, Pueblo, Colo., Ritchie & Finch, 250 w, M.

KGHG

1310 kc, McGehee, Ark., Chas. W. McCollum, 50 w, C.

KGHI

1200 kc, Little Rock, Ark., Berean Bible Class, 100 w, C.

KGHL

950 kc, Billings, Mont., Northwestern Auto Supply Co., 500 w, M.

KGHX

1500 kc, Richmond, Tex., Ft. Bend County School Board, 50 w, C.

KGIQ

1320 kc, Twin Falls, Idaho, Radio Broadcasting Corp., 250 w, M.

KGIR

1360 kc, Butte, Mont., Symons Broadcasting Co., 250 w, M.

KGIW

1420 kc, Trinidad, Colo., Trinidad Creamery Co., 100 w, M.

KGIX

1420 kc, Las Vegas, N. Mex., J. M. Heaton, 100 w, C.

KGJF

890 kc, Little Rock, Ark., First Church of the Nazarene, 250 w, C.

KGKB

1500 kc, Brownwood, Tex., Eagle Publ. Co., 100 w, C.

KGKL

1370 kc, Sar. Angelo, Tex., KGKL, Inc., 100 w, C.

KGKO

570 kc, Wichita Falls, Tex., Wichita Falls Broadcasting Co., 250 w, C.

KGKX

1420 kc, Sandpoint, Idaho, C. E. Twiss and F. H. McCann, 15 w, P.

KGQ

790 kc, Oakland, Calif., General Electric Co., 7500 w, P.

KGRC

1370 kc, San Antonio, Texas, Gene Roth & Co., 100 w, C.

KGRS

1410 kc, Amarillo, Texas, Gish Radio Service, 1000 w, C. Shared.

KGU

940 kc, Honolulu, Hawaii, Marion Mulrony, 1000 w, C. "In the Land of Sunshine, the Future Playground of America."

KGW

620 kc, Portland, Ore., Oregonian Pub. Co., 1000 w, P. "Keep Growing Wiser."

KGY

1200 kc, Lacey, Wash., St. Martins College, 10 w, P. "Out Where the Cedars Meet the Sea." Shared.

KHJ

900 kc, Los Angeles, Calif., Don Lee, Inc., 1000 w, P. "Kindness. Happiness. Joy."

KHQ

590 kc, Spokane, Wash., Louis Wasmer, Inc., 1000 w, P. "In the Friendly City."

KICK

1420 kc, Red Oak, Iowa, Red Oak Radio Corp., 100 w, C.

KID

1320 kc, Idaho Falls, Ida., Jack W. Duckworth, Jr., 250 w, M.

KIDO

1250 kc, Boise, Idaho, F. L. Hill & C. G. Phillips, 1000 w, P.

KIT

1370 kc, Yakima, Wash., C. E. Haymond, 50 w, P.

KJBS

1070 kc, San Francisco, Calif., Julius Brunton & Sons Co., 100 w, P. "The Voice of the Storage Battery."

KJR

970 kc, Seattle, Wash., Northwest Radio Service Co., 5000 w, P.

KLCN

1290 kc, Blytheville, Ark., C. L. Lintzenich, 50 w, C.

KLO

1370 kc, Ogden, Utah, Peery Building Co., 100 w, M.

KLPM

1420 kc, Minot, N. D., E. C. Reineke, 100 w, C.

KLRA

1390 kc, Little Rock, Ark., Arkansas Broadcasting Co., 1000 w, C.

KLS

1440 kc, Oakland, Calif., Warner Bros., 250 w, P. "The City of Golden Opportunity."

KLX

880 kc, Oakland, Calif., Tribune Pub. Co., 500 w, P. "Where Rail and Water Meet."

KLZ

560 kc, Dupont, Colo., Reynolds Radio Co., Inc., 1000 w, M. "The Pioneer Station of the West."

KMA

930 kc, Shenandoah, Iowa, May Seed & Nursery Co., 500 w, C. "Keeps Millions Advised."

KMBC

950 kc, Independence, Mo., Midland Broadcasting Co., 1000 w, C. "The Station Dedicated to Knowledge, Liberty, Divinity and Service."

KMED

1310 kc, Medford, Ore., Mrs. W. J. Virgin, 50 w, P. "See Crater Lake."

KMIC

1120 kc, Inglewood, Calif., Dalton's, Inc., 500 w, P.

KMJ

1210 kc, Fresno, Calif., The Fresno Bee, 100 w, P.

KMMJ

740 kc, Clay Center, Neb., The M. M. Johnson Co., 1000 w, C. The Old Trusty Station."

KMO

1340 kc, Tacoma, Wash., KMO, Inc., 500 w, P.

KMOX

1090 kc, St. Louis, Mo., Voice of St. Louis, Inc., 5000 w, C.

KMTR

570 kc, Hollywood, Calif., KMTR Radio Corp., 1000 w, P. "Your Friend in Hollywood."

KNX

1050 kc, Hollywood, Calif., Western Broadcast Co., 50,000 w, P. "The Voice of Hollywood."

KOA

830 kc, Denver, Colo., General Electric Co., 12,500 w, M.

KOAC

550 kc, Corvallis, Ore., Oregon State Agricultural College, 1000 w, P. "Science for Service."

Service Plus!

It's the *plus* that counts!

Like the "it" in personality, the knockout blow in boxing, or the crashing ace in tennis, it's the punch that counts!

The SUPREME DIAGNOMETER is full of *extra punch!*

Would you patronize a plumber who couldn't stop a leak?

A doctor who couldn't cure a cold?

Then why use servicing equipment that doesn't fill your every need?

That doesn't provide for every test?

That doesn't do justice to your skill?

That doesn't enable you to give service *plus?*

Your customers expect and appreciate SUPREME LEAGUE SERVICE which is the Service *Plus* in radio. You can give SUPREME LEAGUE SERVICE with the SUPREME DIAGNOMETER.



"Set Testers" prove only 29% to 40% efficient in comparison with the SUPREME DIAGNOMETER

Thorough and complete, yet surprisingly simple. The SUPREME RADIO MANUAL gives full instruction and much valuable radio information.

The Only Complete Portable Radio Testing Laboratory

No other radio testing device can anywhere near approach the range, completeness and flexibility of the SUPREME DIAGNOMETER. Make any test you like. Send for ours, which is confidently called "A Test that Challenges Attention." Some of the outstanding features of the SUPREME are:

All tubes tested under actual operating conditions.

Screen grid socket analysis without oscillation.

750 Volt 4 scale A.C. and D.C. meters, 3 scale milliammeter.

Self-contained power plant.

Modulated radiator for testing, synchronizing, neutralizing.

External connections to all apparatus.

Tests both plates '80 type rectifiers.

All continuity tests without batteries.

Universal analyzer plugs.

and a request for complete specifications will reveal numerous other superiorities.

Handy carrying case providing compartments and space for all tools and spare tubes.

750/150/16/4 A.C. Meter.

750/250/100/10 D.C. Meter.

2/12 Ampere-125-25 Milliammeter.

Thermo couple meter for measuring output of a set.

Measures resistances.

Measures capacity of condenser 5 to 9 M.F.D.

Makes all analysis readings.

Supreme Service League



To Radio Owners: Look for this emblem in your radio shop, on the lapel button or card of your service man. It is your guarantee of dependable radio service. Cash in on the prestige the SUPREME SERVICE LEAGUE is building.

Order NOW



Present production permits immediate deliveries but the momentum of sales is such that buyers are cautioned to place their orders now. Reservations will be made against all orders placed for future delivery on specified dates. Make use of this plan to avoid disappointments.

Most good distributors carry the SUPREME DIAGNOMETER in stock. If yours cannot supply you, send order direct on form to right.

SUPREME

Radio Diagonometer

conceivable
Makes every test on any Radio Set-

Supreme Instruments Corp.
345 Supreme Bldg.
Greenwood, Miss.

Please ship SUPREME DIAGNOMETER Model 400-B on basis checked below.

- Net cash \$139.50.
- Time payment plan—\$33.50 cash and 8 monthly payments of \$15.00 each.

All prices are F.O.B. Greenwood, Miss. No dealer's discount.

Date shipment desired.....

Signed.....

Firm Name.....

Street Address.....

City.....

State.....

Please give three or more bank or trade references and names of distributors from whom most purchases are made.

Tell 'Em You Saw It in the Citizens Radio Call Book Magazine and Scientific Digest

- KOB**
1189 kc. State College. N. M., N. M. College of Agri. & Mech. Arts. 10,000 w. M. "The Sunshine State of America."
- KOCW**
1400 kc. Chickasha. Okla., Oklahoma College for Women. 250 w. C.
- KOH**
1370 kc, Reno. Nevada. Jay Peters, Inc., 100 w.
- KOIL**
1260 kc. Council Bluffs. Iowa. Mona Motor Oil Co., 1000 w. C. "The Hilltop Studio."
- KOIN**
940 kc. Portland. Ore., KOIN, Inc., 1000 w. P. "The Station of the Hour."
- KOL**
1270 kc. Seattle. Wash., Seattle Broadcasting Co., 1000 w. P.
- KOMO**
920 kc. Seattle. Wash., Fisher's Blend Station Inc., 1000 w. P.
- KOOS**
1370 kc. Marshfield. Ore., H. H. Hanseth, 50 w. P.
- KORE**
1420 kc. Eugene. Ore., Eugene Broadcast Station. 100 w. P.
- KOY**
1390 kc. Phoenix. Ariz., Nielsen Radio Supply Co., 500 w. M. "Kind Friends Come Back."
- KPCB**
1210 kc. Seattle. Wash., Pacific Coast Biscuit Co., 50 w. P. Shared.
- KPJM**
1500 kc. Prescott. Ariz., Miller & Klahn, 100 w. M.
- KPLA**
1000 kc. Los Angeles. Calif., Pacific Development Radio Co., 1000 w. P.
- KPO**
680 kc. San Francisco. Calif., Hale Bros. & The Chronicle, 5000 w. P. "The City of the Golden Gate."
- KPOF**
880 kc. Denver. Colo., Pillar of Fire, Inc., 500 w. M.
- KPPC**
1200 kc. Pasadena. Calif., Pasadena Presbyterian Church, 50 w. P.
- KPQ**
1210 kc. Seattle. Wash., Taft & Wasmer, Inc., 100 w. P.
- KPRC**
920 kc. Houston. Texas, Houston Printing Co., 1000 w. C. "Kotton Port Rail Center."
- KPSN**
950 kc. Pasadena. Calif., Pasadena Star-News, 1000 w. P.
- KPWF**
1490 kc. Westminster. Calif., Pacific Western Broadcasting Federation, 5,000 w. P.
- KQV**
1380 kc. Pittsburgh. Pa., Doubleday-Hill Elec. Co., 500 w. E. "The Smoky City Station."
- KQW**
1010 kc. San Jose. Calif., First Baptist Church, 500 w. P. "For God and Country."
- KRE**
1370 kc. Berkeley. Calif., First Congregational Church, 100 w. P.
- KREG**
1500 kc. Santa Ana. Calif., Pacific Western Broadcasting Fed., 100 w. P. "Kum West to California."
- KRGV**
1260 kc. Harlingen. Texas, Valley Radio Electric Corp., 500 w.
- KRLD**
1040 kc. Dallas. Texas. KRLD, Inc., 10,000 w. C. "Down Where the Blue Bonnets Grow."
- KRMD**
1310 kc. Shreveport. La., Robert M. Dean, 50 w. C.
- KRSC**
1120 kc. Seattle. Wash., Radio Sales Corp., 50 w. P.
- KSAC**
580 kc. Manhattan. Kan., Kansas State Agricultural College, 500 w. C.
- KSCJ**
1330 kc. Sioux City. Iowa, Perkins Bros. Co., 1000 w. C.
- KSD**
550 kc. St. Louis. Mo., Pulitzer Pub. Co., 500 w. C.
- KSEI**
900 kc. Pocatello. Idaho, KSEI Broadcasting Assn., 250 w. M. "Community Southeast Idaho."
- KSL**
1130 kc. Salt Lake City. Utah, Radio Service Corp., 5000 w. M. "The Voice of the Intermountain Empire."
- KSMR**
1200 kc. Santa Maria. Calif., Santa Maria Valley R. R. Co., 100 w. P. "The Valley of Gardens."
- KSO**
1380 kc. Clarinda. Iowa, Berry Seed Co., 500 w. C. "Keep Serving Others."
- KSOO**
1110 kc. Sioux Falls. S. D., Sioux Falls Broadcasting Assn., 1000 w. C.
- KSTP**
1460 kc. St. Paul. Minn., National Battery Broadcasting Co., 10,000 w. C.
- KTAB**
560 kc. Oakland. Calif., Associated Broadcasters, 500 w. P. "Knowledge. Truth and Beauty."
- KTAP**
1420 kc. San Antonio. Texas. Alamo Broadcasting Co., 100 w. C. "The World's Biggest Little Station."
- KTAT**
1240 kc. Ft. Worth. Texas, Texas Air Transport Broadcasting Co., 1000 w. C.
- KTBI**
1300 kc. Los Angeles. Calif., Bible Institute of Los Angeles, 750 w. P.
- KTBR**
1300 kc. Portland. Ore., M. E. Brown, 500 w. P.
- KTBS**
1450 kc. Shreveport. La., S. R. Elliott and A. C. Steere, 100 w. E.
- KTHS**
1040 kc. Hot Springs. Ark., Chamber of Commerce, 10,000 w. C. "Kum to Hot Springs."
- KTM**
780 kc. Santa Monica. Calif., Pickwick Broadcasting Corp., 500 w. P. "The Station with a Smile."
- KTNT**
1170 kc. Muscatine. Iowa, Norman Baker, 5000 w. C. "The Voice of the Iowa Farmers' Union."
- KTSA**
1290 kc. San Antonio. Texas, Lone Star Broadcast Co., 1000 w. C.
- KTSL**
1310 kc. Shreveport. La., Houseman Sheet Metal Works, Inc., 100 w. C.
- KTSM**
1310 kc. El Paso. Tex., W. S. Bledsoe and W. T. Blackwell, 100 w. C.
- KTUE**
1420 kc. Houston. Texas, Uhalt Electric, 100 w. C.
- KTW**
1270 kc. Seattle. Wash., First Presbyterian Church, 1000 w. P.
- KUJ**
1500 kc. Longview. Wash., F. W. Lovejoy & R. W. Kerfoot, 10 w. P.
- KUOA**
1390 kc. Fayetteville. Ark., University of Arkansas, 1000 w. C.
- KUOM**
570 kc. Missoula. Mont., State University of Montana, 500 w. M.
- KUSD**
890 kc. Vermillion. S. Dak., University of South Dakota, 500 w. C.
- KUT**
1120 kc. Austin. Texas, Kut Broadcasting Co., 500 w. C. "Come to University of Texas."
- KVEP**
1500 kc. Portland. Ore., Schaeffer Radio Co., 15 w. P.
- KVI**
760 kc. Tacoma. Wash., Puget Sound Radio Broadcasting Co., 1000 w. P. "Puget Sound Station."
- KVL**
1370 kc. Seattle. Wash., Arthur C. Bailey, 100 w.
- KVOA**
1260 kc. Tucson. Ariz., R. M. Rieulfi, 500 w.
- KVOO**
1140 kc. Tulsa. Okla., Southwestern Sales Corp., 5000 w. C. "The Voice of Oklahoma."
- KVOS**
1200 kc. Bellingham. Wash., KVOS, Inc., 100 w. M.
- KWCR**
1310 kc. Cedar Rapids. Iowa, Harry F. Paar, 100 w.
- KWEA**
1210 kc. Shreveport. La., William E. Antony, 100 w. C.
- KWG**
1200 kc. Stockton. Calif., Portable Wireless Tel. Co., 100 w. P.

THREE TIMES *the* POWER with the *Lincoln*

PERFECTLY
CONTROLLED

8-40

THE GREATEST ENGINEERED SCREEN GRID SUPER IN RADIO HISTORY

SENSITIVITY
SELECTIVITY
RANGE
TONE
POWER
ONE SPOT



Lincoln 8-40-B

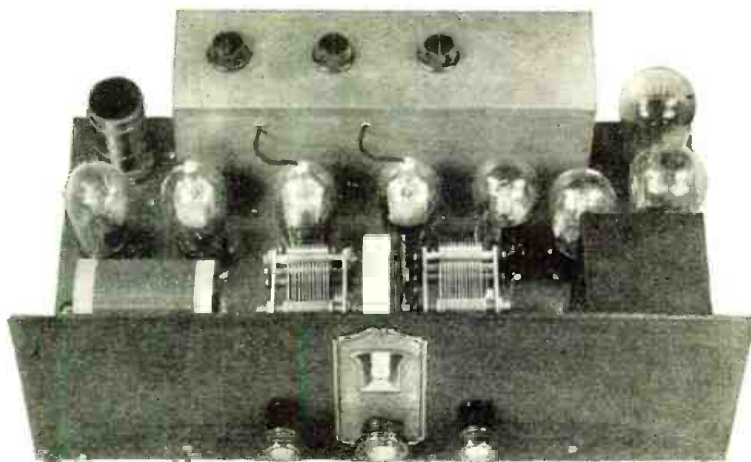

Power Plus Selectivity

THE NEW I. F. AMPLIFIER

Produces a here-to-fore unknown gain per stage, perfectly controlled, allowing every broadcast band to register with clean separation and heavy volume. Set the dial at any point and a station can be tuned in with an adjustment of the trimmer, no matter how far away. Every degree on the dial is "hot."

TUNABLE STAGES

So operative that a slight movement of one control will tune out your local station, producing extreme selectivity which causes stations to actually explode in as dial passes frequency.

DAYLIGHT RECEPTION TELLS THE STORY

Throughout the summer months, the Lincoln 8-40 has pulled in distant reception at high noon, in our laboratory located in a steel-reinforced concrete building in the heart of Chicago. Just imagine what the Lincoln 8-40 would do in your own home.

SETBUILDERS AND DISTRIBUTORS

You can tune into real business without interference from net price catalogs. All sales will be handled direct from our offices with our full co-operation. Write for details covering qualified distributors and special discounts.

LINCOLN RADIO CORPORATION
329 SOUTH WOOD ST. - CHICAGO - ILLINOIS.

Factory Representatives
Australia—New Zealand—Union of
South Africa

JENTS, YORE & WHITEHOUSE
46-48-50 Haig Street
Melbourne, Australia

LINCOLN RADIO CORP., Dept. C
329 S. Wood St., Chicago
Send full information on the
Lincoln 8-40.

Name.....
Address.....
.....

Western Representatives
LINCOLN RADIO SALES AGENCY
200 Davis Street
San Francisco, California

Tell 'Em You Saw It in the Citizens Radio Call Book Magazine and Scientific Digest

- KWJJ**
1060 kc, Portland, Ore., Wilbur Jerman, 500 w, P. "The Voice from Broadway."
- KWK**
1350 kc, St. Louis, Mo., Greater St. Louis Broadcasting Corp., 1000 w, C.
- KWKC**
1370 kc, Kansas City, Mo., Wilson Duncan Broadcasting Co., 100 w.
- KWKH**
850 kc, Kennonwood, La., W. K. Henderson, 5000 w, C.
- KWLC**
1270 kc, Decorah, Iowa, Luther College, 100 w, C.
- KWSC**
1390 kc, Pullman, Wash., State College of Washington, 500 w, P. "The Voice of the Cougars."
- KWWG**
1260 kc, Brownsville, Texas, Chamber of Commerce, 500 w, C. "Good Night, World."
- KXA**
570 kc, Seattle, Wash., American Radio Tel. Co., 500 w, P.
- KXL**
1250 kc, Portland, Ore., KXL Broadcasters, Inc., 500 w, P. "The Voice of Portland."
- KXO**
1200 kc, El Centro, Calif., Irey & Bowles, 100 w, P.
- KXRO**
1420 kc, Aberdeen, Wash., KXRO, Inc., 75 w.
- KYA**
1230 kc, San Francisco, Calif., Pacific Broadcasting Corp., 1000 w, P.
- KYW**
1020 kc, Chicago, Ill., Westinghouse E. & M. Co., 5000 w, C.
- KYWA**
1020 kc, Chicago, Ill., Westinghouse Elec. & Mfg. Co., 500 w, C.
- KZM**
1370 kc, Hayward, Calif., Leon P. Tenney, 100 w, P.
- NAA**
690 kc, 434.5 m, United States Navy Department, Washington, D. C., 1000 w, "Where the Time Signals Originate," E.
- WAAF**
920 kc, Chicago, Ill., Drivers Journal Pub. Co., 500 w daytime, C.
- WAAM**
1250 kc, Newark, N. J., WAAM, Inc., 1000 w, E. "Sunshine Station."
- WAAT**
1070 kc, Jersey City, N. J., Bremer Broadcasting Corp., 300 w.
- WAAW**
660 kc, Omaha, Neb., Omaha Grain Exchange, 500 w daytime, C. "Pioneer Market Station of the West."
- WABC**
860 kc, New York City, N. Y., Atlantic Broadcasting Corp., 5000 w, E.
- WABI**
1200 kc, Bangor, Maine, First Universalist Church, 100 w, E. "The Pine Tree Wave."
- WABO**
See under WHEC.
- WABZ**
1200 kc, New Orleans, La., Coliseum Place Baptist Church, 100 w, C.
- WADC**
1320 kc, Akron, Ohio, Allen T. Simmons, 1000 w, E, shared, "Watch Akron Develop Commercially."
- WAGM**
1310 kc, Royal Oak, Mich., Robert L. Miller, 50 w, E.
- WAIU**
640 kc, Columbus, Ohio, American Insurance Union, 500 w, E. "The Radio Voice of the American Insurance Union."
- WAPI**
1140 kc, Birmingham, Ala., Alabama Polytechnic Institute, 5000 w, C.
- WASH**
1270 kc, Grand Rapids, Mich., Baxter Laundries, Inc., 250 w, C.
- WBAA**
1400 kc, Lafayette, Ind., Purdue University, 500 w, C.
- WBAK**
1430 kc, Harrisburg, Pa., Pennsylvania State Police, 500 w, E. "The Voice of Pennsylvania."
- WBAL**
1060 kc, Baltimore, Md., Consolidated Gas, Elec. Co., 10,000 w, E. "The Station of Good Music."
- WBAP**
800 kc, Ft. Worth, Tex., Carter Publications, Inc., 50,000 w, C.
- WBAW**
1490 kc, Nashville, Tenn., Tennessee Publishing Co., 5000 w, C.
- WBAX**
1210 kc, Wilkes-Barre, Pa., John H. Stenger, Jr., 100 w, E. "In Wyoming Valley, Home of the Anthracite."
- WBBC**
1400 kc, Brooklyn, N. Y., Brooklyn Broadcasting Corp., 500 w.
- WBBL**
1370 kc, Richmond, Va., Grace Covenant Presbyterian Church, 100 w, E. "Richmond, the Gateway North and South."
- WBBM**
770 kc, Chicago, Ill., Atlas Investment Co., 10,000 w, C.
- WBBR**
1300 kc, Rossville, N. Y., People's Pulpit Association, 1000 w, E. "Watch Tower."
- WBBY**
1200 kc, Charleston, S. C., Washington Light Infantry, 75 w, E. "The Seaport of the Southeast."
- WBBZ**
1200 kc, Ponca City, Okla., C. L. Carrell, 100 w, C.
- WBCM**
1410 kc, Bay City, Mich., James E. Davidson, 500 w, E. "Where the Summer Trail Begins."
- WBCN**
See under WENR.
- WBIS**
See under WNAC.
- WBMS**
1450 kc, Fort Lee, N. J., WBMS Broadcasting Corp., 250 w.
- WBNY**
1350 kc, New York, N. Y., Baruchrome Corp., 250 w, E. "The Voice of the Heart of New York."
- WBOQ**
See under WABC.
- WBOW**
1310 kc, Terre Haute, Ind., Banks of Wabash Broadcasting Assn., 100 w, C. "On the Banks of the Wabash."
- WBRC**
930 kc, Birmingham, Ala., Birmingham Broadcasting Co., 500 w, C. "The Biggest Little Station in the World."
- WBRE**
1310 kc, Wilkes-Barre, Pa., Louis G. Baltimore, 100 w, E.
- WBRL**
1430 kc, Tilton, N. H., Booth Radio Laboratories, 500 w, E.
- WBSO**
780 kc, Wellesley Hills, Mass., Babson's Statistical Org., Inc., 250 w, E.
- WBT**
1080 kc, Charlotte, N. C., C. C. Coddington, 5000 w, E, shared, "The Queen City of the South."
- WBZ**
990 kc, Springfield, Mass., Westinghouse E. & M. Co., 15,000 w, E. "The Broadcasting Station of New England."

100% SHIELDING
DYNAMIC
SPEAKER
PUSH PULL AUDIO

RADIO AT ITS BEST



Seven Seas Console

CLARITY and mellowness of tone, hair line selectivity, maximum range and volume without distortion are qualities that all radio builders strive to attain but few achieve. The Seven Seas Console by Leutz, the best that radio experts can produce, gives you all of these desirable features in a set that is equally suitable for use afloat or ashore. And contained in a walnut cabinet by master craftsmen it tastefully harmonizes with the finest furnishings. The Seven Seas Console is also available with complete electric phonograph.

Literature on Request

C. R. LEUTZ, Inc.

Altoona, Pa., U. S. A.

Cables: "Experinfo" New York
 Sales Offices in New York, Los Angeles and Paris

SINGLE DIAL
UNIT
CONSTRUCTION
NINE TUBES

Tell 'Em You Saw It in the Citizens Radio Call Book Magazine and Scientific Digest

WBZA

990 kc, Boston, Mass., Westinghouse E. & M. Co., 500 w, E.

WCAC

600 kc, Storrs, Conn., Connecticut Agricultural College, 250 w, E. "Voice from the Nutmeg State."

WCAD

1220 kc, Canton, N. Y., St. Lawrence University, 500 w, E. "The Voice of the North Country."

WCAE

1220 kc, Pittsburgh, Pa., Kaufman & Baer Co., 500 w, E. "Where Prosperity Begins."

WCAH

1430 kc, Columbus, Ohio, Commercial Radio Service Co., 500 w, E.

WCAJ

590 kc, Lincoln, Neb., Nebraska Wesleyan University, 500 w, C.

WCAL

1250 kc, Northfield, Minn., St. Olaf College, 1000 w, C. "The College on the Hill."

WCAM

1280 kc, Camden, N. J., City of Camden, 500 w, E.

WCAO

600 kc, Baltimore, Md., Monumental Radio, Inc., 250 w, E. "The Gateway of the South."

WCAP

1280 kc, Asbury Park, N. J., Radio Industries Broadcast Co., 500 w, E.

WCAT

1200 kc, Rapid City, S. D., South Dakota State School of Mines, 100 w, M.

WCAU

1170 kc, Philadelphia, Pa., Universal Broadcasting Co., 10,000 w, E. "Where Cheer Awaits U."

WCAZ

1070 kc, Carthage, Ill., Carthage College, 100 w.

WCBA

1440 kc, Allentown, Pa., B. B. Musselman, 250 w, E.

WCBD

1080 kc, Zion, Ill., Wilbur Glen Voliva, 5000 w, C.

WCBM

1370 kc, Baltimore, Md., Baltimore Broadcasting Corp., 100 w, E.

WCBS

1210 kc, Springfield, Ill., Dewing & Meester, 100 w, C.

WCCO

810 kc, Minneapolis, Minn., Northwestern Bdstg., Inc., 15,000 w, C. "Service to the Northwest."

WCDA

1350 kc, New York, N. Y., Italian Educational Broadcasting Co., 250 w, E.

WCFL

970 kc, Chicago, Ill., Chicago Federation of Labor, 1500 w, C. "The Voice of Labor."

WCGU

1400 kc, Coney Island, N. Y., U. S. Broadcasting Corp, 500 w, E.

WCKY

1480 kc, Covington, Ky., L. B. Wilson, 5000 w, E.

WCLB

1500 kc, Long Beach, N. Y., Arthur Faske, 100 w, E. "The Voice of Community Service."

WCLO

1200 kc, Kenosha, Wis., C. Whitmore, 100 w, C.

WCLS

1310 kc, Joliet, Ill., WCLS, Inc., 100 w, C.

WCMA

1400 kc, Culver, Ind., Culver Military Academy, 500 w, C. "The Voice of Culver."

WCOA

1120 kc, Pensacola, Fla., City of Pensacola, 500 w, E. "Wonderful City of Advantages."

WCOC

880 kc, Columbus, Miss., Crystal Oil Co., 500 w, C.

WCOH

1210 kc, Yonkers, N. Y., Westchester Broadcasting Corp., 100 w, E.

WCRW

1210 kc, Chicago, Ill., Clinton R. White, 100 w, C.

WCSH

940 kc, Portland, Me., Congress Square Hotel Co., 500 w, E. "The Voice From Sunrise Land."

WCSO

1380 kc, Springfield, Ohio, Wittenberg College, 500 w, E.

WDAE

620 kc, Tampa, Fla., Tampa Publishing Co., 1000 w, E. "WDAE, the Voice of the Times at Tampa."

WDAF

610 kc, Kansas City, Mo., Kansas City Star Co., 1000 w, C. "Enemies of Sleep."

WDAG

1410 kc, Amarillo, Texas, National Radio & Broadcasting Corp., 250 w, C. "Where Dollars Always Grow."

WDAH

1310 kc, El Paso, Texas, Trinity Methodist Church, 100 w, M.

WDAY

1280 kc, Fargo, N. D., WDAY, Inc., 1000 w, C.

WDBJ

930 kc, Roanoke, Va., Richardson-Wayland Elec. Corp., 250 w, E. "The Magic City."

WDBO

620 kc, Orlando, Fla., Rollins College, Inc., 1000 w, E. "Down Where the Oranges Grow."

WDEL

1120 kc, Wilmington, Del., WDEL, Inc., 250 w, E. "First City of the First State."

WDGY

1180 kc, Minneapolis, Minn., Dr. Geo. W. Young, 1000 w, C.

WDOD

1280 kc, Chattanooga, Tenn., Chattanooga Radio Co., Inc., 500 w, C.

WDRG

1330 kc, New Haven, Conn., Doolittle Radio Corp., 500 w, E.

WDSU

1270 kc, New Orleans, La., Jos. H. Uhalt, 1000 w, C.

WDWF

1210 kc, Providence, R. I., Dutee W. Flint, 100 w, E.

WDZ

1070 kc, Tuscola, Ill., James L. Bush, 100 w.

WEAF

660 kc, New York, N. Y., National Broadcasting Co., Inc., 50,000, w, E.

WEAI

1270 kc, Ithaca, N. Y., Cornell Univ., 500 w, E.

WEAN

780 kc, Providence, R. I., The Shepard Stores Co., 250 w, E. "We Entertain a Nation."

WEAO

550 kc, Columbus, Ohio, Ohio State University, 750 w, E.

WEAR

1070 kc, Cleveland, Ohio, WTAM and WEAR, Inc., 1000 w, E.

WEBC

1280 kc, Duluth, Minn., Head of The Lakes Broadcasting Co., 1000 w, C.

WEBE

1210 kc, Cambridge, Ohio, Roy W. Waller, 100 w, E.

WEBQ

1210 kc, Harrisburg, Ill., First Trust & Savings Bank, 100 w, C.

WEBR

1310 kc, Buffalo, N. Y., Howe'l Broadcasting Co., 100 w, E. "We Extend Buffalo's Regards."

WEBW

600 kc, Beloit, Wis., Beloit College, 350 w, C.

WEDC

1210 kc, Chicago, Ill., Emil Denmark, Inc., 100 w.

WEDH

1420 kc, Erie, Pa., Erie Dispatch-Herald, 30 w, E.

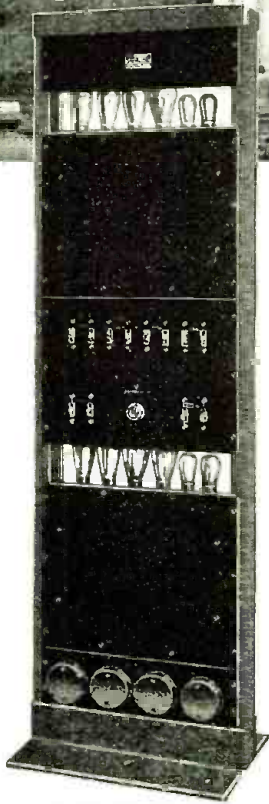

2-V PAM 19

New York Parks are PAM Equipped

In Central Park, New York, programmes such as Goldman's Band, speeches originating in the bandstand, etc., are picked up and amplified by a PAM amplifier similar to that illustrated at the left and fed over wires to twenty-five municipal parks in other sections of the city.



One of
New York's Parks

In each of these other parks is installed a 2V PAM-19 shown above which supplies reproducers located at proper points, thus permitting simultaneous quality reproduction at widely separated points.

The parks in your city are logical prospects for a similar type of equip-

ment. Have you seen your park authorities?

A new 16-page bulletin giving mechanical and electrical characteristics, representative installations, and many new PAM amplifiers will be sent upon receipt of 10 cents in stamps to cover postage. When writing ask for bulletin No. CRCB6.

Main Office:
Canton, Mass.

Samson Electric Co.



Manufacturers Since 1882

Factories at Canton
and Watertown, Mass.

Tell 'Em You Saw It in the Citizens Radio Call Book Magazine and Scientific Digest

- WEEI**
590 kc, Boston, Mass., Edison Elec. Illum. Co., 1000 w, E, "The Friendly Voice."
- WEHS**
1310 kc, Evanston, Ill., Victor C. Carlson, 100 w, C.
- WELK**
1370 kc, Philadelphia, Pa., Howard R. Miller, 100, E.
- WEMC**
590 kc, Berrien Springs, Mich., Emmanuel Missionary College, 1000 w, C, "The Radio Light-house."
- WENR**
870 kc, Chicago, Ill., Great Lakes Radio Broadcasting Co., 50,000 w, C, "Voice of Service."
- WEPS**
1200 kc, Gloucester, Mass., Matheson Radio Co., Inc., 100 w, E.
- WEVD**
1300 kc, New York, N. Y., Debs Memorial Radio Fund, 500 w, E.
- WEW**
760 kc, St. Louis, Mo., St. Louis University, 1000 w, C.
- WFAA**
800 kc, Dallas, Texas, News, 50,000 w, C, "Working for All Alike."
- WFAN**
610 kc, Philadelphia, Pa., Keystone Broadcasting Co., Inc., 500 w, E.
- WFBC**
1200 kc, Knoxville, Tenn., First Baptist Church, 50 w, E.
- WFBG**
1310 kc, Altoona, Pa., William F. Gable Co., 100 w, E, "The Original Gateway to the West and We Wish You All the Very Best."
- WFBJ**
1370 kc, Collegeville, Minn., St. Johns University, 100 w, C, "In the Heart of the Landscape Paradise."
- WFBL**
900 kc, Syracuse, N. Y., The Onondaga Co., Inc., 750 w, E, "When Feeling Blue. Listen."
- WFBM**
1230 kc, Indianapolis, Ind., Indianapolis Power & Light Co., 1000 w, C.
- WFBR**
1270 kc, Baltimore, Md., Baltimore Radio Show, Inc., 250 w, E, "Home of the Star Spangled Banner."
- WFDF**
1310 kc, Flint, Mich., Frank D. Fallain, 100 w, E.
- WFI**
560 kc, Philadelphia, Pa., Strawbridge & Clothier, 500 w, E, "Key City of Industry."
- WFIW**
940 kc, Hopkinsville, Ky., The Acme Mills, Inc., 1000 w, C.
- WFJC**
1450 kc, Akron, Ohio, W. F. Jones Broadcasting, Inc., 500 w, E.
- WFKD**
1310 kc, Philadelphia, Pa., Foulkrod Radio Eng. Co., 50 w, E.
- WFLA**
900 kc, Clearwater, Fla., Clearwater Chamber of Commerce and St. Petersburg Chamber of Commerce, 1000 w, E, "Inviting the World to the Springtime City."
- WGAL**
1310 kc, Lancaster, Pa., Lancaster Elec. Sup. & Const. Co., 15 w, E, "World's Gardens at Lancaster."
- WGBB**
1210 kc, Freeport, N. Y., Harry H. Carman, 100 w, E, "The Voice of the Sunrise Trail."
- WGBC**
1430 kc, Memphis, Tenn., First Baptist Church, 500 w, C, Shared.
- WGBF**
630 kc, Evansville, Ind., Evansville on Air, 500 w, E, "Gateway to the South."
- WGBI**
880 kc, Scranton, Pa., Scranton Broadcasters, Inc., 250 w, E.
- WGBS**
1180 kc, New York, N. Y., General Broadcasting System, Inc., 500 w, E.
- WGCM**
1210 kc, Gulfport, Miss., Gulf Coast Music Co., Inc., 100 w, C.
- WGCP**
1250 kc, Newark, N. J., May Radio Broadcast Corp., 250 w.
- WGES**
1360 kc, Chicago, Ill., Oak Leaves Broadcasting Corp., 500 w, C, "World's Greatest Entertainment Service."
- WGH**
1310 kc, Newport News, Va., Virginia Broadcasting Co., Inc., 100 w, E.
- WGHP**
1240 kc, Detroit, Mich., American Broadcasting Corp., Inc., 750 w, E.
- WGL**
1370 kc, Ft. Wayne, Ind., Allen-Wayne Co., 100 w, C.
- WGMS**
See under WLB.
- WGN**
720 kc, Chicago, Ill., Tribune Co., 25,000 w, C.
- WGR**
550 kc, Buffalo, N. Y., WGR, Inc., 1000 w, E.
- WGST**
890 kc, Atlanta, Ga., Georgia School of Technology, 250 w, E, "The Southern School with the National Reputation."
- WGY**
790 kc, Schenectady, N. Y., General Electric Co., 50,000 w, E.
- WHA**
940 kc, Madison, Wis., University of Wisconsin, 750 w, C.
- WHAD**
1120 kc, Milwaukee, Wis., Marquette University, 250 w, C.
- WHAM**
1150 kc, Rochester, N. Y., Stromberg-Carlson Tel. Mfg. Co., 5000 w, E.
- WHAP**
1300 kc, New York, N. Y., Defenders of Truth Society, Inc., 1000 w, E.
- WHAS**
820 kc, Louisville, Ky., The Courier Journal Co. & Louisville Times Co., 5000 w, C.
- WHAZ**
1300 kc, Troy, N. Y., Rensselaer Polytechnic Institute, 500 w, E.
- WHB**
950 kc, Kansas City, Mo., Sweeney Auto School, 500 w, C.
- WHBC**
1200 kc, Canton, Ohio, St. John's Catholic Church, 10 w, E.
- WHBD**
1370 kc, Bellefontaine, Ohio, F. P. Moler, 100 w, E, "Ohio's Highest Point."
- WHBF**
1210 kc, Rock Island, Ill., Beardsley Specialty Co., 100 w, C.
- WHBL**
1410 kc, Sheboygan, Wis., Press Pub. Co., 500 w, C.
- WHBP**
1310 kc, Johnstown, Pa., Johnstown Automobile Co., 100 w, E, "The Voice of the Friendly City."
- WHBQ**
1370 kc, Memphis, Tenn., Broadcasting Station WHBQ, Inc., 100 w, C.
- WHBU**
1210 kc, Anderson, Ind., Citizens Bank, 100 w, C, "First Hoosier Bank on the Air."
- WHBY**
1200 kc, West De Pere, Wis., St. Norbert's College, 100 w, C.
- WHDF**
1370 kc, Calumet, Mich., C. C. MacLeod, 100 w, C.
- WHDH**
830 kc, Gloucester, Mass., Matheson Radio Co., Inc., 1000 w, E.

Tuned BAND-FILTER

Flat-Top, Straight-Side
10-Kilocycle Selectivity

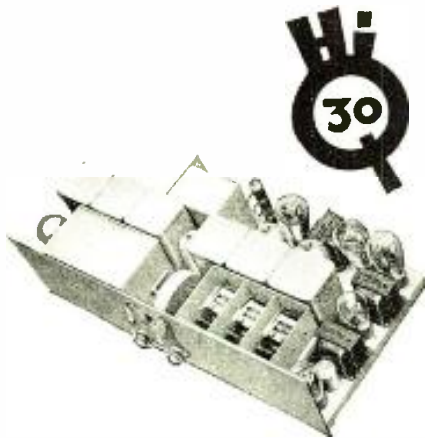

A famous feature exclusive with Hammarlund Receivers for two years.

Gives perfect 10-kilocycle tuning, without cutting side-bands.

Reduces background noises. Improves tone.

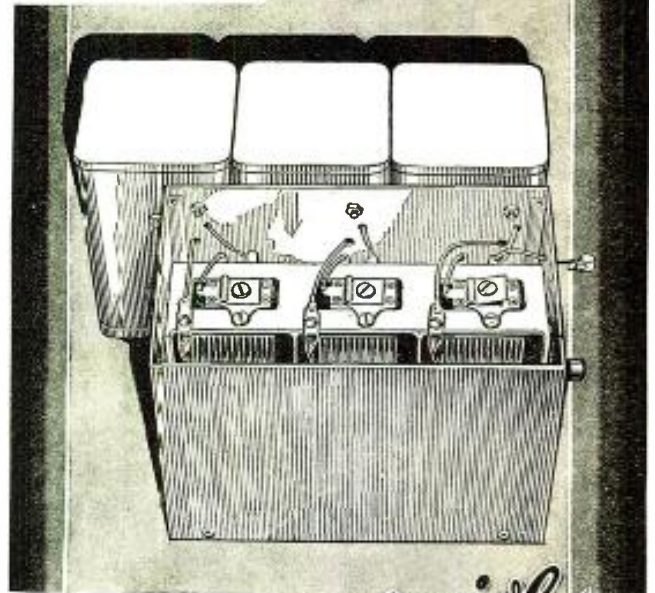

Exclusive

NEVER before, outside of special laboratory models, has there been available to radio constructors such a receiver as the new "HiQ-30."

Its extraordinary features are so far in advance of even previous "HiQ" Models that the loyal army of Hammarlund enthusiasts throughout the world will welcome the "HiQ-30" with nothing short of amazement.

A masterpiece mechanically and electrically, with extraordinary beauty as well. No miscellaneous collection of parts—but *each component specially built* for the characteristics of the circuit and everything to the last screw supplied by the factory.

Perfect selectivity—range limited only by atmospheric conditions—deafening power under velvet control—tone that thrills the music critic—one-dial operation—uses any length antenna—push-pull '45 audio amplifier—permanent phonograph connection—choice of speakers and cabinets, including phono-radio combinations.

Build the "HiQ-30" yourself or we'll recommend a local custom-radio builder to assemble it for you.

Get the "HiQ-30" story *Now*. Mail coupon for 48-page Manual—a wonderful guide book for constructors of modern receivers.

**Completely Wired
Factory-Built Units**

Including Three-Stage Tuned Band Filter—Three-Stage Tuned Screen-Grid Amplifier—Special Power Pack—Six Tuned Circuits—individually and collectively shielded.

The most flexible—the most scientifically perfect—the greatest performing radio of all time.

HAMMARLUND-ROBERTS, INC.
424-438 W. 33rd St., New York



BLACKSTONE
One of nine magnificent "HiQ-30" Special Consoles available from the factory.



WINDSOR
A radio-phonograph combination of rare excellence and distinctive beauty.

**Hammarlund
Custom-Built
RADIO**

Mail Coupon and 25c for "HiQ-30"
HAMMARLUND-ROBERTS, INC., Dept. CR11,
Enclosed 25c (stamps or coin) for "HiQ-30"



MANUAL
424-438 W. 33rd St.
New York

Name _____ Address _____

Tell 'Em You Saw It in the Citizens Radio Call Book Magazine and Scientific Digest

WHDI

1180 kc, Minneapolis, Minn., Wm. Hood Dunwoody Ind. Inst., 500 w, C.

WHDL

1420 kc, Tupper Lake, N. Y., George Franklin Bissell, 10 w, E.

WHEC

1440 kc, Rochester, N. Y., Hickson Electric Co., Inc., 500 w, E.

WHFC

1310 kc, Cicero, Ill., Triangle Broadcasters, 100 w, C.

WHIS

1420 kc, Bluefield, W. Va., Daily Telegraph Printing Co., 100 w, E.

WHK

1390 kc, Cleveland, Ohio, Radio Air Service Corp., 1000 w, E, "Cleveland's Pioneer Station."

WHN

1010 kc, New York, N. Y., Marcus Loew Booking Review, 250 w, E, "Voice of the Great White Way."

WHO

1000 kc, Des Moines, Iowa, Bankers Life Co., 5000 w, C, "W-H-O, Who? Banker's Life, Des Moines."

WHP

1430 kc, Harrisburg, Pa., Pennsylvania Broadcasting Co., 500 w, E.

WIAS

1420 kc, Ottumwa, Iowa, Poling Electric Co., 100 w, C.

WIBA

1210 kc, Madison, Wis., Capital Times Co., 100 w, C.

WIBG

930 kc, Elkins Park, Pa., St. Paul's M. E. Church, 50 w, E.

WIBM

1370 kc, Jackson, Mich., C. L. Carrell, 100 w.

WIBO

570 kc, Chicago, Ill., Nelson Bros. Bond & Mortgage Co., 1000 w, C.

WIBR

1420 kc, Steubenville, Ohio, Thurman A. Owings, 50 w, E, "Where Investments Bring Results."

WIBS

1450 kc, Elizabeth, N. J., New Jersey Broadcasting Co., 250 w, E.

WIBU

1310 kc, Poynette, Wis., W. C. Forrest, 100 w, C.

WIBW

1300 kc, Topeka, Kan., Topeka Broadcasting Assn., Inc., 1000 w, C, "Topeka—Where Investment Brings Wealth."

WIBX

1200 kc, Utica, N. Y., WIBX, Inc., 100 w, E.

WICC

1190 kc, Bridgeport, Conn., Bridgeport Broadcasting Station, Inc., 500 w, E, "The Industrial Capital of Connecticut."

WIL

1200 kc, St. Louis, Mo., Missouri Broadcasting Co., 100 w, C, "A Wave Length Ahead."

WILL

890 kc, Urbana, Ill., University of Illinois, 250 w, C.

WILM

1420 kc, Wilmington, Del., Delaware Broadcasting Co., Inc., 100 w, E.

WINR

1210 kc, Bayshore, N. Y., Radiotel Mfg. Co., 100 w, E, "The Garden Spot of Long Island."

WIOD

560 kc, Miami Beach, Fla., Isle of Dreams Broadcasting Co., 1000 w, E, "Wonderful Isle of Dreams."

WIP

610 kc, Philadelphia, Pa., Gimbel Bros., Inc., 500 w, E, "Watch Its Progress."

WISN

1120 kc, Milwaukee, Wis., Evening Wisconsin Co., 250 w, C.

WJAD

1240 kc, Waco, Texas, Frank P. Jackson, 1000 w, C, shared, "Waco, Texas, All Around It."

WJAG

1060 kc, Norfolk, Neb., Norfolk Daily News, 1000 w, C, "Home of the Printer's Devil."

WJAK

1310 kc, Marion, Ind., J. A. Kautz, 50 w.

WJAR

890 kc, Providence, R. I., The Outlet Co., 250 w, E, "The Southern Gateway of New England."

WJAS

1290 kc, Pittsburgh, Pa., Pittsburgh Radio Supply House, 1000 w, E.

WJAX

1260 kc, Jacksonville, Fla., City of Jacksonville 1000 w, E, "WJAX—W for Wonderful, JAX for Jacksonville."

WJAY

620 kc, Cleveland, Ohio, Cleveland Radio Broadcasting Corp., 500 w, E.

WJAZ

1480 kc, Chicago, Ill., Zenith Radio Corp., 5000 w, C.

WJBC

1200 kc, LaSalle, Ill., Hummer Furniture Co., 100 w, C.

WJBI

1210 kc, Red Bank, N. J., Robt. S. Johnson, 100 w, E.

WJBK

1370 kc, Ypsilanti, Mich., J. F. Hopkins, 50 w, C.

WJBL

1200 kc, Decatur, Ill., Wm. Gusbard Dry Goods Co., 100 w, C.

WJBO

1370 kc, New Orleans, La., Valdemar Jensen, 100 w, C.

WJBT

See under WBBM.

WJBU

1210 kc, Lewisburg, Pa., Bucknell University, 100 w, E, "In the Heart of the Keystone State."

WJBW

1200 kc, New Orleans, La., C. Carlsen, Jr., 30 w, C, "The Serve You Broadcasting Station at New Orleans."

WJBY

1210 kc, Gadsden, Ala., C. J. Black, 50 w, C.

WJDW

1370 kc, Emory, Va., Emory and Henry College, 100 w, E.

WJDX

1270 kc, Jackson, Miss., Lamar Life Ins. Co., 500 w, C.

WJDZ

1310 kc, Winston-Salem, N. C., The Journal Co., 100 w, E.

WJJD

1130 kc, Mooseheart, Ill., Loyal Order of Moose, 20,000 w, C, shared, "Every Child Is Entitled to a High School Education and a Trade."

WJKS

1360 kc, Gary, Ind., Johnson-Kennedy Radio Corp., 500 w, C.

WJR

750 kc, Detroit, Mich., WJR, Inc., 5000 w, E.

WJSV

1460 kc, Mt. Vernon Hills, Va., Independent Pub. Co., 10,000 w.

WJW

1210 kc, Mansfield, Ohio, Mansfield Broadcasting Association, 100 w, E.

WJZ

760 kc, New York City, N. Y., Radio Corporation of America, 30,000 w, E.

WKAQ

890 kc, San Juan, Porto Rico, Radio Corp. of Porto Rico, 500 w, E, "Porto Rico, The Island of Enchantment in the Caribbean Sea."

WKAR

1040 kc, East Lansing, Mich., Michigan State College, 1000 w, E.

WKAV

1310 kc, Laconia, N. H., Laconia Radio Club, 100 w, E, "The Voice of the Winnepesaukee Lake Region."

WKBB

1310 kc, Joliet, Ill., Sanders Bros., 100 k, C.

WKBC

1310 kc, Birmingham, Ala., R. B. Bryoles Furniture Co., 100 w, C.

WKBF

1400 kc, Indianapolis, Ind., Noble Butler Watson, 500 w, C, "We Keep Building Friendships."



TOBE By-Pass-Filter Condenser
Price, 1.0 Mfd., \$1.25



TOBE 400 Line Short Path Condensers
Price, 1.0 Mfd., \$2.00



TOBE 600 Line Condensers for Power Pack Work
Price, 1.0 Mfd., \$2.50



TOBE 1300 Line Hi-Voltage Surgproof
Price, 1.0 Mfd., \$3.50



TOBE Transmitting Condensers
Price, 2.0 Mfd., \$14.00



TOBE Majestic Eliminator Replacement Blocks
Price, "A" Block, \$10.00
"B" Block, \$10.00

SINCE 1922 Tobe apparatus has been standard with Newark Electric Company. During years of examination and test, we have found the apparatus to be rugged, carefully designed and above all faithfully guaranteed. We know of no better line of Condensers to meet the current needs.



New TOBE A Supply
Price \$24.75

Newark Electric Company realizing the importance of radio interference suppression has prepared to extend quick delivery on Filterettes and answer any requests for information on radio interference.



TOBE By-Pass and Filter Condensers
Price, 1 Mfd., \$1.00



TOBE Junior Filterette
Price \$3.50



TOBE Senior Filterette
Price \$7.50



TOBE Filterette No. 110 P.O.
Price \$12.50



TOBE Filterette No. 11
Price \$10.00



TOBE Filterette No. 110
Price \$15.00



TOBE DA Filterette
Price \$5.00

Write for Complete Tobe Catalog and Discounts



NEWARK ELECTRIC CO.
"Nothing But Radio"

226 West Madison Street Chicago, Illinois

WKBH

1380 kc, LaCrosse, Wis., Callaway Music Co., 1000 w, C.

WKBI

1310 kc, Chicago, Ill., Fred L. Schoenwolf, 50 w, C.

WKBN

570 kc, Youngstown, Ohio, W. P. Williamson, Jr., 500 w, E.

WKBO

1450 kc, Jersey City, N. J., Camith Corp., 250 w, E.

WKBP

1420 kc, Battle Creek, Mich., Enquirer-News Co., 50 w, E.

WKBQ

1350 kc, New York, N. Y., Standard Cahill Co., Inc., 250 w, E.

WKBS

1310 kc, Galesburg, Ill., Permil N. Nelson, 100 w, C.

WKBV

1500 kc, Brookville, Ind., Knox Battery & Electric Co., 100 w, C.

WKBW

1470 kc, Buffalo, N. Y., Churchill Evan. Assn., Inc., 5000 w, E.

WKBZ

1500 kc, Ludington, Mich., K. L. Ashbacker, 50 w.

WKEN

1040 kc, Buffalo, N. Y., WKEN, Inc., 1000 w, E.

WKJC

1200 kc, Lancaster, Pa., Kirk Johnson & Co., 100 w, E.

WKRC

550 kc, Cincinnati, Ohio, J. S. Boyd, 500 w, E, "WKRC, K—Kodel, R—Radio, C—Corporation."

WKY

900 kc, Oklahoma City, Okla., WKY Radiophone Co., 1000 w, C.

WLAC

1490 kc, Nashville, Tenn., Life & Casualty Ins. Co., 5000 w, C, "The Thrift Station."

WLAP

1200 kc, Louisville, Ky., American Broadcasting Corp. of Kentucky, 30 w, C.

WLB

1250 kc, Minneapolis, Minn., University of Minnesota, 500 w, C.

WLBC

1310 kc, Muncie, Ind., Donald A. Burton, 50 w.

WLBF

1420 kc, Kansas City, Kan., Everett L. Dillard, 100 w, C, "Where Listeners Become Friends."

WLBG

1200 kc, Petersburg, Va., Robert Allen Gamble, 100 w, E.

WLBL

900 kc, Stevens Point, Wis., Wisconsin Department of Markets, 2000 w, daytime, C, "Wisconsin, Land of Beautiful Lakes."

WLBW

1260 kc, Oil City, Pa., Radio-Wired Program Corp., 500 w, E.

WLBX

1500 kc, Long Island City, N. Y., John N. Brahy, 100 w.

WLBZ

620 kc, Bangor, Me., Maine Broadcasting Co., 250 w, E.

WLCI

1210 kc, Ithaca, N. Y., Lutheran Assn. of Ithaca, 50 w, E.

WLEX

1360 kc, Lexington, Mass., Lexington Air Station, 500 w, E.

WLEY

1420 kc, Lexington, Mass., Lexington Air Station, 100 w, E.

WLIB

See under WGN.

WLIT

560 kc, Philadelphia, Pa., Lit Brothers, 500 w, E, "The Quaker City Siren."

WLOE

1500 kc, Boston, Mass., Boston Broadcasting Co., 100 w.

WLS

870 kc, Chicago, Ill., Agricultural Broadcasting Co., 5000 w, C.

WLSI

See under WDFW.

WLTH

1400 kc, Brooklyn, N. Y., Voice of Brooklyn, Inc., 500 w, E.

WLW

700 kc, Cincinnati, Ohio, Crosley Radio Corp., 50,000 w, E.

WLWL

1100 kc, New York, N. Y., Missionary Society of St. Paul, 5000 w, 6-8 pm, E.

WMAC

570 kc, Casenovia, N. Y., Clive B. Meredith, 250 w, E, "Voice of Central New York."

WMAF

1360 kc, Dartmouth, Mass., Round Hills Radio Corp., 500 w, E.

WMAK

900 kc, Buffalo, N. Y., WMAK Broadcasting System, Inc., 750 w, E.

WMAL

630 kc, Washington, D. C., M. A. Leese Co., 250 w, E.

WMAN

1210 kc, Columbus, Ohio, W. E. Heskitt, 50 w, E.

WMAQ

670 kc, Chicago, Ill., Chicago Daily News, Inc., 5000 w, C.

WMAY

1200 kc, St. Louis, Mo., Kingshighway Presbyterian Church, 100 w, C.

WMAZ

890 kc, Macon, Ga., Macon Junior Chamber of Commerce, 250 w, E, shared, "Watch Mercer Attain Zenith."

WMBA

1500 kc, Newport, R. I., LeRoy Joseph Beebe, 100 w, E.

WMBC

1420 kc, Detroit, Mich., Michigan Broadcasting Co., Inc., 100 w, E.

WMBD

1440 kc, Peoria Heights, Ill., Peoria Heights Radio Laboratory, 500 w.

WMBG

1210 kc, Richmond, Va., Havens & Martin, Inc., 100 w, E, "The Daytime Station."

WMBH

1420 kc, Joplin, Mo., Edwin Dudley Aber, 100 w, C, "Where Memories Bring Happiness."

WMBI

1080 kc, Chicago, Ill., Moody Bible Institute Radio Station, 5000 w, C, shared, "The West Point of Christian Service."

WMBJ

1500 kc, Pittsburgh, Pa., Rev. J. W. Sproul, 100, E.

WMBL

1310 kc, Lakeland, Fla., Benford's Radio Studios, 100 w, E, "Lakeland—The City of Heart's Desire."

WMBO

1370 kc, Auburn, N. Y., Radio Service Laboratories, 100 w, E.

WMBQ

1500 kc, Brooklyn, N. Y., Paul J. Gollhofer, 100 w.

WMBR

1210 kc, Tampa, Fla., F. J. Reynolds, 100 w, E, "WMBR, Everything for Radio at Tampa, Fla."

WMC

780 kc, Memphis, Tenn., Memphis Commercial Appeal, Inc., 500 w, C, "WMC, Memphis, Down in Dixie."

WMCA

570 kc, New York, N. Y., Knickerbocker Broadcasting Co., Inc., 500 w, E, "Where the White Way Begins."

WMES

1500 kc, Boston, Mass., Massachusetts Educational Society, 50 w.

WMMN

890 kc, Fairmont, W. Va., Holt Rome Novelty Co., 250 w, E.

WMPD

1500 kc, Lapeer, Mich., First Methodist Protestant Church, 100 w, E, "Where Many Preach Christ."

WMRJ

1420 kc, Jamaica, N. Y., Peter J. Prinz, 10 w, E, "The Gateway of the Sunrise Trail."

WMSG

1350 kc, New York, N. Y., Madison Square Garden Broadcast Co., 250 w, E.

Why toil for small wages?

RADIO

offers you **BIG PAY!**



Free Book tells how to
Pick the Job You Want
... Many fill it
in only 9 Months

SPEED up your earning capacity ... get out of the low pay rut ... make more money than you ever made before ... in Radio—the big-money business of today. Hundreds of men just like you are earning from \$2,000 to \$25,000 a year in this giant money-making industry.

Astounding World-Wide Opportunities Beckon To You

Be one of the fortunate men to get in on the ground floor of this big-money industry. Broadcasting stations and manufacturers are eagerly seeking capable graduates—and now nation-wide Radio telegraph service, telephony, television, photoradiograms have opened up new and amazing opportunities by the thousands!

Magnificent Laboratory Outfit Makes It Easy To Learn At Home

You don't have to know an antenna from a vacuum tube. By means of this marvelous, simplified home-training course, sponsored by the Radio Corporation of America ... you can now prepare for success in every phase of radio. The remarkable outlay of apparatus given to you with this course ... enables you to learn by actual practice how to solve every problem in Radio work ... such as repairing, installing and servicing fine sets. That's why you, too, upon graduation can have the confidence and ability to command big money.

Only Training Course Backed by Radio Corporation of America

Graduates of this school are always posted in newest up-to-the-minute developments in Radio. That's why they are always in big

A few months of expert training through this "big league" home-laboratory method prepares you for success as a broadcast operator at \$1,800 to \$4,800 a year
—or, as a radio inspector at from \$2,000 to \$4,500 a year.

If you have dash and daring ... if you long for excitement—adventure—thrills ... become a radio operator.
\$90 to \$200 a month (board free) and a chance to see the world.

demand. The progress of Radio is measured by the accomplishments of the great engineers in the huge research laboratories of the Radio Corporation of America. This gigantic corporation sets the standards for the entire industry ... and sponsors every lesson in the course.

Money Back If Not Satisfied

This marvelous home-laboratory training practically insures your success by preparing you thoroughly in every phase of Radio manufacturing, servicing, broadcasting, photoradiograms, television and airplane radio equipment. As a student, you will receive an agreement signed by the president of this school assuring you of complete satisfaction upon completion of your training—or your money will be instantly refunded.

Free!

This fascinating book on Radio's glorious FREE opportunities ... written by one of America's well-known radio experts.



RADIO INSTITUTE OF AMERICA,
Dept. CB 11, 326 Broadway, New York, N. Y.

Gentlemen: Please send me your FREE 50-page book which illustrates the brilliant opportunities in Radio and describes your laboratory-method of instruction at home.

Name

Address

RADIO INSTITUTE OF AMERICA

SPONSORED BY



- WMT**
1200 kc, Waterloo, Iowa, Waterloo Broadcasting Co., 100 w, C.
- WNAC**
1230 kc, Boston, Mass., The Shepard Norwell Co., 1000 w, E.
- WNAD**
1010 kc, Norman, Okla., University of Oklahoma 500 w, C, "The Voice of Soonerland."
- WNAT**
1310 kc, Philadelphia, Pa., Lenning Brothers Co., 100 w, E.
- WNAX**
570 kc, Yankton, S. Dak., Gurney Seed & Nursery Co., Dakota Radio Apparatus Co., 1000 w, C.
- WNBF**
1500 kc, Binghamton, N. Y., Howitt-Wood Radio Co., 50 w, E, "The Voice of the Triple Cities."
- WNBH**
1310 kc, New Bedford, Mass., New Bedford Broadcasting Co., 100 w, E, shared, "The Gateway to Cape Cod."
- WNBK**
1310 kc, Knoxville, Tenn., Lonsdale Baptist Church, 50 w, C.
- WNBO**
1200 kc, Washington, Pa., J. B. Spriggs, 100 w, E.
- WNBR**
1430 kc, Memphis, Tenn., John Ulrich, 500 w, C.
- WNBW**
1200 kc, Carbondale, Pa., Home Cut Glass & China Co., 5 w, E.
- WNBX**
1200 kc, Springfield, Vt., First Congregational Church, Inc., 10 w, E.
- WNBZ**
1290 kc, Saranac Lake, N. Y., Smith & Mace, 50 w, E.
- WNJ**
1450 kc, Newark, N. J., Radio Investment Co., 250 w, E, "The Voice of Newark."
- WNOX**
560 kc, Knoxville, Tenn., Stercki Bros., 1000 w, C, "Smoky Mountain Station."
- WNRC**
1440 kc, Greensboro, N. C., Wayne M. Nelson, 250 w, E.
- WNYC**
570 kc, New York, N. Y., Department of Plant & Structures, 500 w, E, "Municipal Broadcasting Station of the City of New York."
- WOAI**
1190 kc, San Antonio, Texas, Southern Equipment Co., 5000 w, C, "The Winter Playground of America."
- WOAN**
600 kc, Lawrenceburg, Tenn., J. D. Vaughan, 500 w, C, "Watch Our Annual Normal."
- WOAX**
1280 kc, Trenton, N. J., Franklyn J. Wolff, 500 w, E, "Trenton Makes, the World Takes."
- WOBT**
1310 kc, Union City, Tenn., Titsworth's Radio & Music Shop, 15 w, C.
- WOBU**
580 kc, Charleston, W. Va., Charleston Radio Broadcasting Co., 250 w, E.
- WOC**
1000 kc, Davenport, Iowa, Palmer School of Chiropractic, 5000 w, C.
- WOCL**
1210 kc, Jamestown, N.Y., A. E. Newton, 25 w, E.
- WODA**
1250 kc, Paterson, N. J., Richard E. O'Dea, 1000 w, E, "The Voice of the Silk City."
- WOI**
560 kc, Ames, Iowa, Iowa State College, 3500 w, C.
- WOKO**
1440 kc, Poughkeepsie, N. Y., H. E. Smith and R. M. Curtis, 500 w, E.
- WOL**
1310 kc, Washington, D. C., American Broadcasting Co., 100 w, E.
- WOMT**
1210 kc, Manitowoc, Wis., Francis M. Kadow, 100 w.
- WOPI**
1500 kc, Bristol, Tenn., Radiophone Service Co., 100 w, E.
- WOOD**
1270 kc, Grand Rapids, Mich., Walter B. Stiles, Inc., 500 w, C, "The Voice of the Whispering Pines."
- WOQ**
610 kc, Kansas City, Mo., Unity School of Christianity, 1000 w, C.
- WOR**
710 kc, Newark, N. J., L. Bamberger & Co., 5000 w, E.
- WORC**
1200 kc, Auburn, Mass., K. & B. Electric Co., 100 w, E.
- WORD**
1480 kc, Chicago, Ill., People's Pulpit Association, 5000 w, C, "The Watch Tower—Radio WORD."
- WOS**
630 kc, Jefferson City, Mo., State Marketing Bureau, 500 w, C, "Watch Our State."
- WOV**
1130 kc, New York, N. Y., International Broadcasting Corp., 1000 w, E.
- WOW**
590 kc, Omaha, Neb., Woodmen of the World, 1000 w, C, "The Omaha Station."
- WOWO**
1160 kc, Ft. Wayne, Ind., Main Auto Supply Co., 10,000 w, C.
- WPAP**
See under WQAO.
- WPAW**
1210 kc, Pawtucket, R. I., Shartenberg & Robinson, 100 w, E, "The City of Diversified Industries."
- WPCC**
570 kc, Chicago, Ill., North Shore Congregational Church, 500 w, C.
- WPCH**
810 kc, New York, N. Y., Eastern Broadcasters, Inc., 500 w, E.
- WPEN**
1500 kc, Philadelphia, Pa., Wm. Penn Broadcasting Co., 100 w, E, "First Wireless School in America."
- WPG**
1100 kc, Atlantic City, N. J., Municipality of Atlantic City, 5000 w, E.
- WPOE**
1420 kc, Patchogue, N. Y., Nassau Broadcasting Corp., 30 w, E.
- WPOR**
See under WTAR.
- WPRC**
1200 kc, Harrisburg, Pa., Wilson Printing & Radio Co., 100 w, E.
- WPSC**
1230 kc, State College, Pa., Pennsylvania State College, 500 w, day, E, "The Voice of the Nittany Lion."
- WPTF**
680 kc, Raleigh, N. C., Durham Life Insurance Co., 1,000 w, E.
- WQAM**
1240 kc, Miami, Fla., Miami Broadcasting Co., 100 w, E.
- WQAN**
880 kc, Scranton, Pa., Scranton Times, 250 w, E.
- WQAO**
1010 kc, New York, N. Y., Calvary Baptist Church, 250 w, E.
- WQBC**
1360 kc, Utica, Miss., Utica Chamber of Commerce, 300 w, C.
- WQBZ**
1420 kc, Weirton, W. Va., J. H. Thompson, 60 k, E.
- WRAF**
1200 kc, La Porte, Ind., The Radio Club, Inc., 100 w.
- WRAC**
1370 kc, Erie, Pa., C. R. Cummins, 50 w, E.
- WRAP**
1310 kc, Reading, Pa., Avenue Radio & Electric Shop, 100 w, E, "The Schuylkill Valley Echo."
- WRAX**
1020 kc, Philadelphia, Pa., Berachah Church, Inc., 250 w, E.



“Your set is certainly tone-true now, Bill!”

—And indeed it is. Bill knows the difference now between ordinary “radioed” music and that which the AmerTran Power Amplifier and Hi-Power Box gives him. And his friends do, as well.

Anyone can get the same results, just take out the inferior audio system—replace it with the best that money can buy—and your set, no matter how old or out of date will be better

in tone to the most expensive receivers on the market.

The new AmerTran Power Amplifier—push pull for 210 tubes and the improved ABC Hi-Power Box will do the trick or if you do not want to spend that much money use the push-pull amplifier for 171 tubes or a pair of AmerTran De Luxe transformers. Any AmerTran outfit will give you improved reception. See your dealer or write to us today.



AmerTran ABC Hi-Power Box—500 volts DC plate voltage, current up to 110 ma; AC filament current for all tubes for any set. Adjustable bias voltages for all tubes. Price, east of Rockies—less tubes—\$130.00.



Complete 2 stage audio amplifier. First stage AmerTran DeLuxe for UX 227 AC and second stage AmerTran Push-Pull for two 171 or two 210 Power Tubes. Price, east of Rockies—less tubes—\$80.00.

AMERICAN TRANSFORMER COMPANY
Transformer Manufacturers for more than 29 years
98 Emmet St. Newark, N. J.

AMERTRAN

Tell 'Em You Saw It in the Citizens Radio Call Book Magazine and Scientific Digest

WRBC

1240 kc, Valparaiso, Ind., Immanuel Lutheran Church, 500 w, C, "World Redeemed by Christ."

WRBI

1310 kc, Tifton, Ga., Kent's Furniture & Music Store, 20 w, E.

WRBJ

1500 kc, Hattiesburg, Miss., Woodruff Furniture Co., 10 w, C.

WRBL

1200 kc, Columbus, Ga., David Parmer, 50 w, E.

WRBQ

1210 kc, Greenville, Miss., J. Pat Scully, 100 w, C.

WRBT

1370 kc, Wilmington, N. C., Wilmington Radio Association, 100 w, E.

WRBU

1210 kc, Gastonia, N. C., A. J. Kirby Music Co., 100 w, E.

WRC

950 kc, Washington, D. C., Radio Corporation of America, 500 w, E, "The Voice of the Capital."

WREC

600 kc, Whitehaven, Tenn., WREC, Inc., 500 w.

WREN

1220 kc, Lawrence, Kan., Jenny Wren Co., 1000 w, C.

WRHM

1250 kc, Minneapolis, Minn., Rosedale Hospital Co., Inc., 1000 w, C, "Welcome Rosedale Hospital, Minneapolis."

WRJN

1370 kc, Racine, Wis., Racine Broadcasting Corp., 100 w, C.

WRK

1310 kc, Hamilton, Ohio, S. W. Doron & John C. Slade, 100 w, E, "The Voice of Hamilton."

WRNY

1010 kc, New York, N. Y., Aviation Radio Station, 250 w, E.

WRR

1280 kc, Dallas, Texas, City of Dallas, 500 w, C.

WRUF

1470 kc, Gainesville, Fla., University of Florida, 5000 w, E.

WRVA

1110 kc, Richmond, Va., Larus Bros. & Co., Inc., 5000 w, E, "Carry Me Back to Old Virginny."

WSAI

1330 kc, Cincinnati, Ohio, Crosley Radio Corp., 500 w, E, "The Gateway to Dixie."

WSAJ

1310 kc, Grove City, Pa., Grove City College, 100 w, E.

WSAN

1440 kc, Allentown, Pa., Allentown Call Pub. Co., 250 w, E, "We Serve Allentown Nationality." ity."

WSAR

1450 kc, Fall River, Mass., Doughty & Welch Electrical Co., Inc., 250 w, E.

WSAZ

580 kc, Huntington, W. Va., McKellar Electric Co., 250 w, E.

WSB

740 kc, Atlanta, Ga., Atlanta Journal Co., 1000 w, E, "The Voice of the South."

WSBC

1210 kc, Chicago, Ill., World Battery Co., 100 w, C.

WSBT

1230 kc, South Bend, Ind., South Bend Tribune, 500 w, C.

WSDA

See under WSGH.

WSGH

1400 kc, Brooklyn, N. Y., Amateur Radio Specialty Co., 500 w.

WSIX

1210 kc, Springfield, Tenn., 638 Tire & Vulcanizing Co., 100 w, C.

WSM

650 kc, Nashville, Tenn., National Life & Accident Ins. Co., 5000 w, C, "We Shield Millions."

WSMB

1320 kc, New Orleans, La., Saenger Theaters, Inc., & Maison Blanche Co., 500 w, C, "America's Most Interesting City."

WSMK

570 kc, Dayton, Ohio, Stanley M. Krohn, Jr., 200 w, C, "The Home of Aviation."

WSOA

1480 kc, Forest Park, Ill., Radiophone Broadcasting Corp., 5000 w, C.

WSPD

1340 kc, Toledo, Ohio, Toledo Broadcasting Co., 500 w, E.

WSSH

1420 kc, Boston, Mass., Tremont Temple Baptist Church, 100 w, E, "Stranger's Sunday Home."

WSUI

580 kc, Iowa City, Iowa, State Univ. of Iowa, 500 w, C, "The Old Gold Studio."

WSUN

See under WFLA.

WSVS

1370 kc, Buffalo, N. Y., Seneca Vocational School, 50 w, E, "Watch Seneca Vocational School."

WSYR

570 kc, Syracuse, N. Y., Clive B. Merewith, 250 w, E.

WTAD

1440 kc, Quincy, Ill., Illinois Stock Medicine Broadcasting Corp., 500 w.

WTAG

580 kc, Worcester, Mass., Worcester Telegram Pub. Co., Inc., 250 w, E, "The Voice From the Heart of the Commonwealth."

WTAM

1070 kc, Cleveland, Ohio, WTAM & WEAR, Inc., 3500 w, E, "The Voice From the Storage Battery."

WTAQ

1330 kc, Eau Claire, Wis., Gillette Rubber Co., 1000 w, C.

WTAR

780 kc, Norfolk, Va., WTAR Radio Corp., 500 w, E.

WTAW

1120 kc, College Station, Texas, Agri. & Mech. College of Texas, 500 w, C.

WTAX

1210 kc, Streator, Ill., Williams Hardware Co., 50 w.

WTBO

1420 kc, Cumberland, Md., Cumberland Electric Co., 50 w, E.

WTFI

1450 kc, Toccoa, Ga., Toccoa Falls Institute, 250 w, E.

WTIC

1060 kc, Hartford, Conn., Travels Broadcasting Service Corp., 50,000 w, E, "The Insurance City."

WTMJ

620 kc, Milwaukee, Wis., Milwaukee Journal, 1000 w, C.

WTOC

1410 kc, Savannah, Ga., Chamber of Commerce, 500 w, E.

WWAE

1200 kc, Hammond, Ind., Hammond-Calumet Broadcasting Corp., 100 w.

WWJ

920 kc, Detroit, Mich., The Detroit News, 1000 w, E.

WWL

850 kc, New Orleans, La., Loyola University, 5000 w, C.

WWNC

570 kc, Asheville, N. C., Citizens Broadcasting Co., 1000 w, E.

WWRL

1500 kc, Woodside, N. Y., Long Island Broadcasting Corp., 100 W.

WWVA

1160 kc, Wheeling, W. Va., West Virginia Broadcasting Corp., 5000 w, E.

FREE!

LAST CHANCE

YOU can enjoy the perfect reproduction and the unusual convenience of this Midget Cone Speaker **absolutely free**. Manufactured by one of the largest manufacturers in the country, this speaker has innumerable advantages in portability and perfect tone. Ideal for apartment use, or in different rooms of the house, the Midget Speaker is delighting thousands who are now using it.



From Elizabeth, N. J.:

"I received the Midget speaker today. It's great and I am well pleased."

Richard Ogden.

From Ocean Breeze, Cal., W. P. McGuide writes: "I received your Midget Speaker and sure was surprised by its performance. I play all distant stations just as good as any speaker I've had, and it performs dandy."

One of these speakers may be yours absolutely free, by just filling in the coupon below for one year's subscription to the Citizens Radio Call Book Magazine. Because the supply is **limited**, do not delay in sending in the coupon. Remember this is your last chance.

Mail Coupon Today!

CITIZENS RADIO SERVICE BUREAU
508 So. Dearborn St., Chicago, Ill.

Here's my \$1.75 (Foreign \$2.00), for which please send me Citizens Radio Call Book Magazine for one year, beginning September November January March

This subscription entitles me to a free Midget Loudspeaker.

NAME.....

STREET & NO.....

CITY.....STATE.....

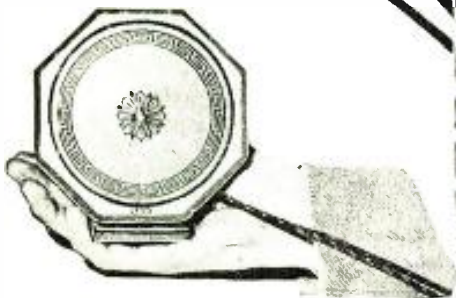

Tell 'Em You Saw It in the Citizens Radio Call Book Magazine and Scientific Digest

Consolidated Broadcast List

Call	Town	Call	Town	Call	Town	Call	Town	Call	Town
KCRC—Enid, Okla.		KGY—Lacey, Wash.		WBAP—Fort Worth, Tex.		WHAS—Louisville, Ky.		WMBQ—Brooklyn, N. Y.	
KDB—Santa Barbara, Calif.		KHJ—Los Angeles, Calif.		WBAY—Nashville, Tenn.		WHAZ—Troy, N. Y.		WMBR—Tampa, Fla.	
KDFN—Casper, Wyo.		KHQ—Spokane, Wash.		WBAX—Wilkes-Barre, Pa.		WHB—Kansas City, Mo.		WMC—Memphis, Tenn.	
KDKA—East Pittsburgh, Pa.		KIC—Red Oak, Ia.		WBBC—Brooklyn, N. Y.		WHBC—Canton, Ohio		WMCB—New York, N. Y.	
KDLR—Devils Lake, N. D.		KID—Idaho Falls, Idaho		WBBL—Richmond, Va.		WHBD—Bellefontaine, Ohio		WMCA—Boston, Mass.	
KDYI—Salt Lake City, Utah		KIDO—Boise, Idaho		WBBL—Chicago, Ill.		WHBF—Rock Island, Ill.		WMEN—Fairmont, W. Va.	
KEIK—Beverly Hills, Calif.		KIT—Yakima, Wash.		WBBI—Rossville, N. Y.		WHBL—Sheboygan, Wis.		WMPN—Lapeer, Mich.	
KEJAW—Burbank, Calif.		KJBS—San Francisco, Calif.		WBBS—Charleston, S. C.		WHBR—Johnstown, Pa.		WMRJ—Jamaica, N. Y.	
KEX—Portland, Ore.		KJR—Seattle, Wash.		WBZ—Ponca City, Okla.		WHBQ—Memphis, Tenn.		WMSG—New York, N. Y.	
KFAB—Lincoln, Neb.		KLCN—Blithville, Ark.		WBCN—Bay City, Mich.		WHBU—Anderson, Ind.		WMT—Waterloo, Ia.	
KFAD—Phoenix, Ariz.		KLO—Ogden, Utah		WBOS—Boston, Mass.		WHBY—West De Pere, Wis.		WNAC—Boston, Mass.	
KFBB—Great Falls, Mont.		KLPM—Minot, N. D.		WBOS—Port Lee, N. J.		WHDF—Calumet, Mich.		WNAD—Norman, Okla.	
KFBK—Sacramento, Calif.		KLRA—Little Rock, Ark.		WBOS—New York, N. Y.		WHDI—Minneapolis, Minn.		WNAT—Philadelphia, Pa.	
KFBI—Everett, Wash.		KLX—Oakland, Calif.		WBOS—New York, N. Y.		WHDL—Tupper Lake, N. Y.		WNAX—Yankton, S. D.	
KFDM—Beaumont, Tex.		KLZ—Dupont, Colo.		WBOS—Terre Haute, Ind.		WHDC—Rochester, N. Y.		WNBH—New Bedford, Mass.	
KFDY—Brookings, S. D.		KMA—Shenandoah, Ia.		WBOS—Birmingham, Ala.		WHFC—Cicero, Ill.		WNBK—Knoxville, Tenn.	
KFEI—Denver, Colo.		KMBC—Independence, Mo.		WBRE—Wilkes-Barre, Pa.		WHIS—Bluefield, W. Va.		WNBW—Memphis, Tenn.	
KFEQ—St. Joseph, Mo.		KMED—Medford, Ore.		WBRL—Tilton, N. H.		WHK—Cleveland, Ohio		WNBX—Springfield, Vt.	
KFGQ—Boons, Iowa		KMIC—Ingewood, Calif.		WBSO—Wellesley Hills, Mass.		WHN—New York, N. Y.		WNBZ—Saranac Lake, N. Y.	
KFH—Wichita, Kans.		KMJ—Fresno, Calif.		WBT—Charlotte, N. C.		WIAS—Ottumwa, Ia.		WNJ—Newark, N. J.	
KFHA—Gunnison, Colo.		KMMJ—Clay Center, Neb.		WBZ—Springfield, Mass.		WIBA—Madison, Wis.		WNON—Knoxville, Tenn.	
KFI—Los Angeles, Calif.		KMO—Tacoma, Wash.		WBZA—Boston, Mass.		WIBG—Elkins Park, Pa.		WNRN—Greensboro, N. C.	
KFIF—Portland, Ore.		KMOX—St. Louis, Mo.		WCAC—Storrs, Conn.		WIBW—Jackson, Mich.		WNYC—New York, N. Y.	
KFIO—Spokane, Wash.		KMTR—Hollywood, Calif.		WCAD—Canton, N. Y.		WIBO—Chicago, Ill.		WOAI—San Antonio, Tex.	
KFIZ—Fond du Lac, Wis.		KNX—Hollywood, Calif.		WCAE—Pittsburgh, Pa.		WIBR—Steubenville, Ohio		WOAN—Lawrenceville, Tenn.	
KFJB—Marshalltown, Iowa.		KOA—Denver, Colo.		WCAJ—Lincoln, Neb.		WIBU—Poyette, Wis.		WOAT—Clinton City, Tenn.	
KFJF—Oklahoma City, Okla.		KOAC—Corvallis, Ore.		WCAK—Columbus, Ohio		WIBW—Topeka, Kans.		WOC—Davenport, Ia.	
KFJI—Astoria, Ore.		KOAC—State College, N. M.		WCAJ—Lincoln, Neb.		WIBX—Utica, N. Y.		WOCL—Jamestown, N. Y.	
KFJM—Grand Forks, N. D.		KOCH—Chickasha, Okla.		WCAK—Northfield, Minn.		WICB—Bridgeport, Conn.		WODA—Paterson, N. J.	
KFJK—Portland, Ore.		KOH—Reno, Nev.		WCAK—Camden, N. J.		WIL—St. Louis, Mo.		WOL—Amen, Ia.	
KFY—Fort Dodge, Ia.		KOIL—Council Bluffs, Ia.		WCAO—Baltimore, Md.		WILM—Wilmington, Del.		WOKO—Poughkeepsie, N. Y.	
KFYZ—Fort Worth, Tex.		KOIN—Portland, Ore.		WCAP—Asbury Park, N. J.		WWR—Bay Shore, N. Y.		WOL—Washington, D. C.	
KFA—Greeley, Colo.		KOL—Seattle, Wash.		WCAT—Rapid City, S. D.		WIOD—Miami Beach, Fla.		WOMT—Manitowoc, Wis.	
KFKB—Milford, Kans.		KOMO—Seattle, Wash.		WCAU—Philadelphia, Pa.		WIP—Philadelphia, Pa.		WOPR—Bristol, Tenn.	
KFKU—Lawrence, Kans.		KOOS—Marshfield, Ore.		WCAZ—Carthage, Ill.		WISN—Milwaukee, Wis.		WOOD—Grand Rapids, Mich.	
KFKX—Chicago, Ill.		KORE—Eugene, Ore.		WCBR—Allentown, Pa.		WJAI—Norfolk, Neb.		WOQ—Kansas City, Mo.	
KFKZ—Kirkville, Mo.		KOY—Phoenix, Ariz.		WCBZ—Zion, Ill.		WJAK—Marion, Ind.		WORC—Newark, N. J.	
KFLY—Rockford, Ill.		KPCB—Seattle, Wash.		WCBM—Baltimore, Md.		WJAS—Jacksonville, Fla.		WORC—Chicago, Ill.	
KFLX—Galveston, Tex.		KPCM—Prescott, Ariz.		WCBZ—Springfield, Ill.		WJAY—Cleveland, Ohio		WORD—Chicago, Ill.	
KFMN—Northfield, Minn.		KPLA—Los Angeles, Calif.		WCCO—Minneapolis, Minn.		WJAZ—Chicago, Ill.		WOS—Jefferson City, Mo.	
KFNF—Shenandoah, Ia.		KPAC—San Francisco, Calif.		WCHA—New York, N. Y.		WJBC—LaSalle, Ill.		WOV—New York, N. Y.	
KFOR—Lincoln, Neb.		KPAC—Denver, Colo.		WCFB—Chicago, Ill.		WJBI—Red Bank, N. J.		WOW—Omaha, Neb.	
KFOX—Long Beach, Calif.		KPAC—Pasadena, Calif.		WCGU—Coney Island, N. Y.		WJBL—Decatur, Ill.		WOWO—Ft. Wayne, Ind.	
KFPD—Dublin, Tex.		KPAC—Seattle, Wash.		WCKY—Covington, Ky.		WJBO—New Orleans, La.		WPAP—New York, N. Y.	
KFPN—Greenville, Tex.		KPAC—Houston, Tex.		WCLB—Long Beach, N. Y.		WJBT—Chicago, Ill.		WPAT—Pawtucket, R. I.	
KFPV—Sioux Falls, S. D.		KPAC—Pasadena, Calif.		WCLC—Kenosha, Wis.		WJBT—New Orleans, La.		WPCC—Chicago, Ill.	
KFPY—Spokane, Wash.		KPAC—Pasadena, Calif.		WCLD—Joliet, Ill.		WJBT—New Orleans, La.		WPCH—New York, N. Y.	
KFOA—St. Louis, Mo.		KPAC—Pasadena, Calif.		WCLM—Chicago, Ill.		WJBT—New Orleans, La.		WPEN—Philadelphia, Pa.	
KFOU—Holy City, Calif.		KPAC—Pasadena, Calif.		WCLM—Chicago, Ill.		WJBT—New Orleans, La.		WPEN—Philadelphia, Pa.	
KFQW—Seattle, Wash.		KPAC—Pasadena, Calif.		WCLM—Chicago, Ill.		WJBT—New Orleans, La.		WPEN—Philadelphia, Pa.	
KFQZ—Hollywood, Calif.		KPAC—Pasadena, Calif.		WCLM—Chicago, Ill.		WJBT—New Orleans, La.		WPEN—Philadelphia, Pa.	
KFRD—San Francisco, Calif.		KPAC—Pasadena, Calif.		WCLM—Chicago, Ill.		WJBT—New Orleans, La.		WPEN—Philadelphia, Pa.	
KFRU—Columbia, Mo.		KPAC—Pasadena, Calif.		WCLM—Chicago, Ill.		WJBT—New Orleans, La.		WPEN—Philadelphia, Pa.	
KFSD—San Diego, Calif.		KPAC—Pasadena, Calif.		WCLM—Chicago, Ill.		WJBT—New Orleans, La.		WPEN—Philadelphia, Pa.	
KFSG—Los Angeles, Calif.		KPAC—Pasadena, Calif.		WCLM—Chicago, Ill.		WJBT—New Orleans, La.		WPEN—Philadelphia, Pa.	
KFUL—Galveston, Tex.		KPAC—Pasadena, Calif.		WCLM—Chicago, Ill.		WJBT—New Orleans, La.		WPEN—Philadelphia, Pa.	
KFUM—Colorado Spgs., Colo.		KPAC—Pasadena, Calif.		WCLM—Chicago, Ill.		WJBT—New Orleans, La.		WPEN—Philadelphia, Pa.	
KFUG—St. Louis, Mo.		KPAC—Pasadena, Calif.		WCLM—Chicago, Ill.		WJBT—New Orleans, La.		WPEN—Philadelphia, Pa.	
KFUP—Denver, Colo.		KPAC—Pasadena, Calif.		WCLM—Chicago, Ill.		WJBT—New Orleans, La.		WPEN—Philadelphia, Pa.	
KFV—Culver City, Calif.		KPAC—Pasadena, Calif.		WCLM—Chicago, Ill.		WJBT—New Orleans, La.		WPEN—Philadelphia, Pa.	
KFVS—Cape Girardeau, Mo.		KPAC—Pasadena, Calif.		WCLM—Chicago, Ill.		WJBT—New Orleans, La.		WPEN—Philadelphia, Pa.	
KFWB—Hollywood, Calif.		KPAC—Pasadena, Calif.		WCLM—Chicago, Ill.		WJBT—New Orleans, La.		WPEN—Philadelphia, Pa.	
KFWF—St. Louis, Mo.		KPAC—Pasadena, Calif.		WCLM—Chicago, Ill.		WJBT—New Orleans, La.		WPEN—Philadelphia, Pa.	
KFWI—San Francisco, Calif.		KPAC—Pasadena, Calif.		WCLM—Chicago, Ill.		WJBT—New Orleans, La.		WPEN—Philadelphia, Pa.	
KFWM—Oakland, Calif.		KPAC—Pasadena, Calif.		WCLM—Chicago, Ill.		WJBT—New Orleans, La.		WPEN—Philadelphia, Pa.	
KFXD—Jerome, Idaho		KPAC—Pasadena, Calif.		WCLM—Chicago, Ill.		WJBT—New Orleans, La.		WPEN—Philadelphia, Pa.	
KFXF—Denver, Colo.		KPAC—Pasadena, Calif.		WCLM—Chicago, Ill.		WJBT—New Orleans, La.		WPEN—Philadelphia, Pa.	
KFXJ—Edgewater, Colo.		KPAC—Pasadena, Calif.		WCLM—Chicago, Ill.		WJBT—New Orleans, La.		WPEN—Philadelphia, Pa.	
KFXM—Ontario, Calif.		KPAC—Pasadena, Calif.		WCLM—Chicago, Ill.		WJBT—New Orleans, La.		WPEN—Philadelphia, Pa.	
KFXR—Oklahoma City, Okla.		KPAC—Pasadena, Calif.		WCLM—Chicago, Ill.		WJBT—New Orleans, La.		WPEN—Philadelphia, Pa.	
KFY—Flagstaff, Ariz.		KPAC—Pasadena, Calif.		WCLM—Chicago, Ill.		WJBT—New Orleans, La.		WPEN—Philadelphia, Pa.	
KFYD—Abilene, Tex.		KPAC—Pasadena, Calif.		WCLM—Chicago, Ill.		WJBT—New Orleans, La.		WPEN—Philadelphia, Pa.	
KFYH—Bismarck, N. D.		KPAC—Pasadena, Calif.		WCLM—Chicago, Ill.		WJBT—New Orleans, La.		WPEN—Philadelphia, Pa.	
KGA—Spokane, Wash.		KPAC—Pasadena, Calif.		WCLM—Chicago, Ill.		WJBT—New Orleans, La.		WPEN—Philadelphia, Pa.	
KGAR—Tucson, Ariz.		KPAC—Pasadena, Calif.		WCLM—Chicago, Ill.		WJBT—New Orleans, La.		WPEN—Philadelphia, Pa.	
KGB—San Diego, Calif.		KPAC—Pasadena, Calif.		WCLM—Chicago, Ill.		WJBT—New Orleans, La.		WPEN—Philadelphia, Pa.	
KGBU—Ketchikan, Alaska.		KPAC—Pasadena, Calif.		WCLM—Chicago, Ill.		WJBT—New Orleans, La.		WPEN—Philadelphia, Pa.	
KGBX—St. Joseph, Mo.		KPAC—Pasadena, Calif.		WCLM—Chicago, Ill.		WJBT—New Orleans, La.		WPEN—Philadelphia, Pa.	
KGBZ—York, Neb.		KPAC—Pasadena, Calif.		WCLM—Chicago, Ill.		WJBT—New Orleans, La.		WPEN—Philadelphia, Pa.	
KGCA—Decorah, Ia.		KPAC—Pasadena, Calif.		WCLM—Chicago, Ill.		WJBT—New Orleans, La.		WPEN—Philadelphia, Pa.	
KGCI—San Antonio, Tex.		KPAC—Pasadena, Calif.		WCLM—Chicago, Ill.		WJBT—New Orleans, La.		WPEN—Philadelphia, Pa.	
KGCR—Watertown, S. D.		KPAC—Pasadena, Calif.		WCLM—Chicago, Ill.		WJBT—New Orleans, La.		WPEN—Philadelphia, Pa.	
KGCU—Mandan, N. D.		KPAC—Pasadena, Calif.		WCLM—Chicago, Ill.		WJBT—New Orleans, La.		WPEN—Philadelphia, Pa.	
KGDX—Wolf Point, Mont.		KPAC—Pasadena, Calif.		WCLM—Chicago, Ill.		WJBT—New Orleans, La.		WPEN—Philadelphia, Pa.	
KGDA—Dell Rapids, S. D.		KPAC—Pasadena, Calif.		WCLM—Chicago, Ill.		WJBT—New Orleans, La.		WPEN—Philadelphia, Pa.	
KGDE—Fergus Falls, Minn.		KPAC—Pasadena, Calif.		WCLM—Chicago, Ill.		WJBT—New Orleans, La.		WPEN—Philadelphia, Pa.	
KGDM—Stockton, Calif.		KPAC—Pasadena, Calif.		WCLM—Chicago, Ill.		WJBT—New Orleans, La.		WPEN—Philadelphia, Pa.	
KGDR—San Antonio, Tex.		KPAC—Pasadena, Calif.		WCLM—Chicago, Ill.		WJBT—New Orleans, La.		WPEN—Philadelphia, Pa.	
KGDY—Oldham, S. D.		KPAC—Pasadena, Calif.		WCLM—Chicago, Ill.		WJBT—New Orleans, La.		WPEN—Philadelphia, Pa.	
KGEF—Los Angeles, Calif.		KPAC—Pasadena, Calif.		WCLM—Chicago, Ill.		WJBT—New Orleans, La.		WPEN—Philadelphia, Pa.	
KGEK—Yuma, Colo.		KPAC—Pasadena, Calif.		WCLM—Chicago, Ill.		WJBT—New Orleans, La.		WPEN—Philadelphia, Pa.	
KGER—Long Beach, Calif.		KPAC—Pasadena, Calif.		WCLM—Chicago, Ill.		WJBT—New Orleans, La.		WPEN—Philadelphia, Pa.	
KGEW—Fort Morgan, Colo.		KPAC—Pasadena, Calif.		WCLM—Chicago, Ill.		WJBT—New Orleans, La.		WPEN—Philadelphia, Pa.	
KGEZ—Kalispell, Mont.		KPAC—Pasadena, Calif.		WCLM—Chicago, Ill.		WJBT—New Orleans, La.		WPEN—Philadelphia, Pa.	
KGF—Alva, Okla.		KPAC—Pasadena, Calif.		WCLM—Chicago, Ill.		WJBT—New Orleans, La.		WPEN—Philadelphia, Pa.	
KGFF—Oklahoma City, Okla.		KPAC—Pasadena, Calif.		WCLM—Chicago, Ill.		WJBT—New Orleans, La.		WPEN—Philadelphia, Pa.	
KGFI—Corpus Christi, Tex.		KPAC—Pasadena, Calif.		WCLM—Chicago, Ill.		WJBT—New Orleans, La.		WPEN—Philadelphia, Pa.	
KGFJ—Los Angeles, Calif.		KPAC—Pasadena, Calif.		WCLM—Chicago, Ill.		WJBT—New Orleans, La.		WPEN—Philadelphia, Pa.	
KGFK—Hickory, N. M.		KPAC—Pasadena, Calif.		WCLM—Chicago, Ill.		WJBT—New Orleans, La.		WPEN—Philadelphia, Pa.	
KGFL—Raton, N. M.		KPAC—Pasadena, Calif.		WCLM—Chicago, Ill.		WJBT—New Orleans, La.		WPEN—Philadelphia, Pa.	
KGFV—Ravenna, Neb.		KPAC—Pasadena, Calif.		WCLM—Chicago, Ill.		WJBT—New Orleans, La.		WPEN—Philadelphia, Pa.	
KGFN—Pierre, S. D.		KPAC—Pasadena, Calif.		WCLM—Chicago, Ill.		WJBT—New Orleans, La.		WPEN—Philadelphia, Pa.	
KGGC—San Francisco, Calif.		KPAC—Pasadena, Calif.		WCLM—Chicago, Ill.		WJBT—New Orleans, La.		WPEN—Philadelphia, Pa.	
KGGF—Picher, Okla.		KPAC—Pasadena, Calif.		WCLM—Chicago, Ill.		WJBT—New Orleans, La.		WPEN—Philadelphia, Pa.	
KGGH—Albuquerque, N. M.		KPAC—Pasadena, Calif.		WCLM—Chicago, Ill.		WJBT—New Orleans, La.		WPEN—Philadelphia, Pa.	
KGHF—Pueblo, Colo.		KPAC—Pasadena, Calif.		WCLM—Chicago, Ill.		WJBT—New Orleans, La.		WPEN—Philadelphia, Pa.	
KGHG—McGehee, Ark.		KPAC—Pasadena, Calif.		WCLM—Chicago, Ill.		WJBT—New Orleans, La.		WPEN—Philadelphia, Pa.	
KGHI—Little Rock, Ark.		KPAC—Pasadena, Calif.		WCLM—Chicago, Ill.		WJBT—New Orleans, La.		WPEN—Philadelphia, Pa.	
KGHJ—Billings, Mont.		KPAC—Pasadena, Calif.		WCLM—Chicago, Ill.		WJBT—New Orleans, La.		WPEN—Philadelphia, Pa.	
KGHK—Richmond, Tex.		KPAC—Pasadena, Calif.		WCLM—Chicago, Ill.		WJBT—New Orleans, La.		WPEN—Philadelphia, Pa.	
KGIQ—Twin Falls, Idaho		KPAC—Pasadena, Calif.		WCLM—Chicago, Ill.		WJBT—New Orleans, La.		WPEN—Philadelphia, Pa.	
KGIR—Butte, Mont.		KPAC—Pasadena, Calif.		WCLM—Chicago, Ill.		WJBT—New Orleans, La.		WPEN—Philadelphia, Pa.	
KGIW—Trinidad, Colo.		KPAC—Pasadena, Calif.		WCLM—Chicago, Ill.		WJBT—New Orleans, La.		WPEN—Philadelphia, Pa.	
KGIX—Las Vegas, N. M.		KPAC—Pasadena, Calif.		WCLM—Chicago, Ill.		WJBT—New Orleans, La.		WPEN—Philadelphia, Pa.	
KGJF—Little Rock, Ark.		KPAC—Pasadena, Calif.		WCLM—Chicago, Ill.		WJBT—New Orleans, La.		WPEN—Philadelphia, Pa.	
KGKB—Brownwood, Tex.		KPAC—Pasadena, Calif.		WCLM—Chicago, Ill.		WJBT—New Orleans, La.		WPEN—Philadelphia, Pa.	
KGKI—San Angelo, Tex.		KPAC—Pasadena, Calif.		WCLM—Chicago, Ill.		WJBT—New Orleans, La.		WPEN—Philadelphia, Pa.	
KGKO—Wichita Falls, Tex.		KPAC—Pasadena, Calif.		WCLM—Chicago, Ill.		WJBT—New Orleans, La.		WPEN—Philadelphia, Pa.	
KGKN—Sandpoint, Idaho		KPAC—Pasadena, Calif.		WCLM—Chicago, Ill.		WJBT—New Orleans, La.		WPEN—Philadelphia, Pa.	
KGO—Oakland, Calif.		KPAC—Pasadena, Calif.		WCLM—Chicago, Ill.		WJBT—New Orleans, La.		WPEN—Philadelphia, Pa.	
KGRC—San Antonio, Tex.		KPAC—Pasadena, Calif.		WCLM—Chicago, Ill.		WJBT—New Orleans, La.		WPEN—Philadelphia, Pa.	
KGRS—Amarillo, Tex.		KPAC—Pasadena, Calif.		WCLM—Chicago, Ill.		WJBT—New Orleans, La.		WPEN—Philadelphia, Pa.	
KGU—Honolulu, T. H.		KPAC—Pasadena, Calif.		WCLM—Chicago, Ill.		W			

HERE IS THE PERFECT BROADCAST RECEIVER

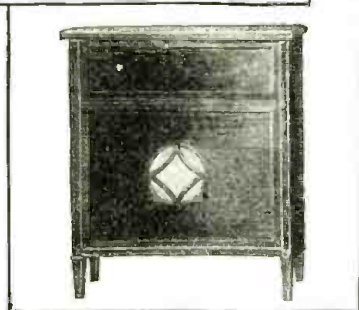

The New Admiralty Super-10 is the very apex of Modern Research Engineering.

It is a brand new receiver for the radio connoisseur which we believe represents final superiority over any broadcast receiver now being manufactured or contemplated.

Strictly custom-built, this new model meets the requirements of those that want the best. It is, in fact, the Highest Class Receiver in the World.

SUPER FEATURES

10 Radio Tubes—Super Power—Complete self-contained electric operation—Exceedingly compact—Simplified controls—Full Vision Tuning Indicators—Uses Heater type A.C. Screen Grid and Power Tubes—Super Selective—Band Pass Filter Effect—Hum Eliminator—Line Voltage regulation—Scientifically correct shielding—Great range with sensitivity control—Minimum antenna requirements—Improved push-pull audio system—Perfect reproduction with great volume—Arranged for Electro-Dynamic Loudspeaker—Adaptable for short-wave television work—Universal wave-length range for use in any part of the

world—Phonograph pickup connection—Special Weston Meters for voltage and tuning resonance—Protected against moisture for tropical and marine installation—Built strictly according to U. S. Navy Standards—Cabinets of finest selected Mahogany and Walnut Exquisite console combinations available—Entirely custom built—Thorough air test by receiving engineers on all classes of reception for range and quality of reproduction—Sold direct from factory and through selected franchise dealers in the principal cities of the United States and foreign countries—Unconditionally guaranteed against defects.

**THE
NEW**

Attractive illustrated descriptive literature on request

ADMIRALTY SUPER-10

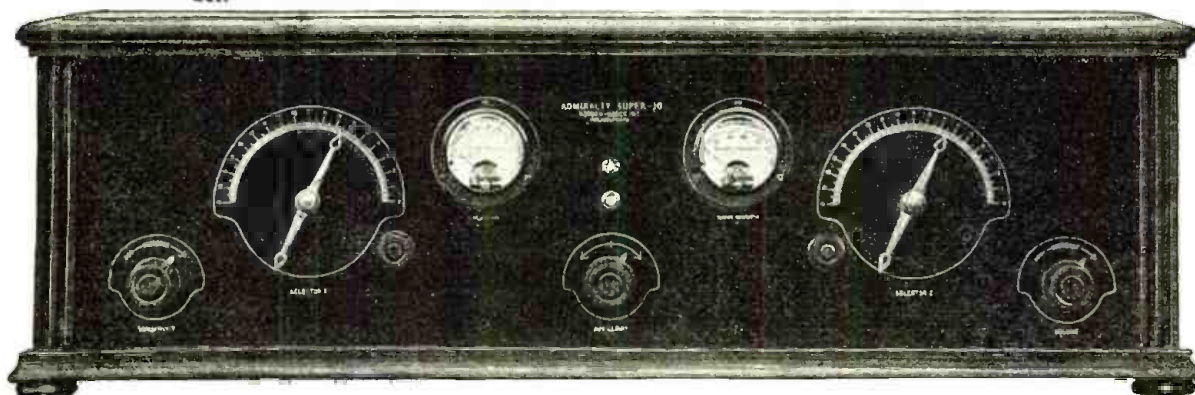

Write, telegraph or cable today!

NORDEN-HAUCK, INC., Engineers

N. W. Cor. Delaware Avenue and South Street

Cable: NORHAUCK

Philadelphia, Pa., U. S. A.

Tell 'Em You Saw It in the Citizens Radio Call Book Magazine and Scientific Digest

U. S. Broadcasting Stations by Frequencies

550 Kilocycles, 545.1 Meters:

KOAC, WGR, WEAQ, WKRC, KFUD, KSD, KFDY, KFYR.

560 Kilocycles, 535.4 Meters:

WLIT, WFI, KFDM, WNOX, WOI, KFEQ, KTAB, KLZ, WIOD

570 Kilocycles, 526.0 Meters:

WNYC, WMCA, WSYR, WMAC, WSMK, WKBN, WNNC, KGKO, WNAX, WPCC, WIBO, KUOM, KXA, KMTR.

580 Kilocycles, 516.9 Meters—Canadian Shared:

WTAG, WOBV, WSAZ, KGFX, KSAC, WSUI

590 Kilocycles, 508.2 Meters:

WEEI, WEMC, WCAJ, WOW, KHQ

600 Kilocycles, 499.7 Meters—Canadian Shared:

WTIC, WCAO, WREC, WOAN, WEBW, KFSD, WCAC

610 Kilocycles, 491.5 Meters:

WFAN, WIP, WDAF, WOQ, KFRC

620 Kilocycles, 483.6 Meters:

WLBZ, WDBO, WDAE, WTMJ, KGW, KFAD, WJAY

630 Kilocycles, 475.9 Meters—Canadian Shared:

WMAL, WOS, KFRU, WGBF

640 Kilocycles, 468.5 Meters:

WAIU, KFI

650 Kilocycles, 461.3 Meters:

WSM

660 Kilocycles, 454.3 Meters:

WEAF, WAAW

670 Kilocycles, 447.5 Meters:

WMAQ

680 Kilocycles, 440.9 Meters:

WPTF, KPO

690 Kilocycles, 434.5 Meters—Canadian Wave:

700 Kilocycles, 428.3 Meters:

WLW

710 Kilocycles, 422.3 Meters:

WOR, KFVD

720 Kilocycles, 416.4 Meters:

WGN, WLIB

730 Kilocycles, 410.7 Meters—Canadian Wave:

740 Kilocycles, 405.2 Meters:

WSB, KMMJ

750 Kilocycles, 399.8 Meters:

WJR

760 Kilocycles, 394.5 Meters:

WJZ, WEW, KVI

770 Kilocycles, 389.4 Meters:

KFAB, WBBM, WJBT

780 Kilocycles, 384.4 Meters—Canadian Shared:

WRSO, WTAR, WPOR, KELW, KTM, WMC, WEAN

790 Kilocycles, 379.5 Meters:

WGY, KGO

800 Kilocycles, 374.8 Meters:

WBAP, WFAA

810 Kilocycles, 370.2 Meters:

WPCH, WCCO

820 Kilocycles, 365.6 Meters:

WHAS

830 Kilocycles, 361.2 Meters:

KOA, WHDH

840 Kilocycles, 356.9 Meters—Canadian Wave:

850 Kilocycles, 352.7 Meters:

KWKH, WWL

860 Kilocycles, 348.6 Meters:

WBOQ, WABC, KFQZ

870 Kilocycles, 344.6 Meters:

WLS, WENR, WBCN

880 Kilocycles, 340.7 Meters—Canadian Shared:

WQAN, WGBI, WCOC, KLX, KPOF, KFKA

890 Kilocycles, 336.9 Meters—Canadian Shared:

WJAR, WMMN, WMAZ, WGST, KGJF, WILL, KUSD, KFNF, WKAQ

900 Kilocycles, 331.1 Meters:

WFRL, WMAK, WKY, WFLA, WSUN, WLBL, KHJ, KSEI, KGBU

910 Kilocycles, 329.5 Meters—Canadian Wave:

920 Kilocycles, 325.9 Meters:

WWJ, KPRC, WAAF, KOMO

930 Kilocycles, 322.4 Meters—Canadian Shared:

WIBG, WDBJ, WBRC, KGBZ, KMA, KFWM, KFWI

940 Kilocycles, 319 Meters:

WCSH, WFIW, KOIN, KGU, KFEL, KFXF, WHA

950 Kilocycles, 315.6 Meters:

WRC, KMBC, KFVB, KPSN, KGHL, WHB

960 Kilocycles, 312.3 Meters—Canadian Wave:

970 Kilocycles, 309.1 Meters:

WCFL, KJR

980 Kilocycles, 305.9 Meters:

KDKA

990 Kilocycles, 302.8 Meters:

WBZ, WBZA

1000 Kilocycles, 299.8 Meters:

WHO, WOC, KPLA

1010 Kilocycles, 296.9 Meters—Canadian Shared:

WQAO, WPAP, WHN, WRNY, KGGF, WNAD, KQW

1020 Kilocycles, 293.9 Meters:

KYW, KFKX, KYWA, WRAX

1030 Kilocycles, 291.1 Meters—Canadian Wave:

1040 Kilocycles, 288.3 Meters:

WKEN, WKAR, KTHS, KRLD

1050 Kilocycles, 285.5 Meters:

KNX, KFKB

1060 Kilocycles, 282.8 Meters:

WBAL, WJAG, KWJJ, WTIC

1070 Kilocycles, 280.2 Meters:

WAAT, WTAM, WEAR, WCAZ, WDW, KJBS

1080 Kilocycles, 277.6 Meters:

WBT, WCBT, WMBI

1090 Kilocycles, 275.1 Meters:

KMOX, KFQA

1100 Kilocycles, 272.6 Meters:

WPG, WLWL, KGDM

1110 Kilocycles, 270.1 Meters:

WRVA, KSOO

1120 Kilocycles, 267.7 Meters—Canadian Shared:

WCOA, WTAW, KUT, WISN, WHAD, KFSG, KMIC, KRSC, WDEL

1130 Kilocycles, 265.3 Meters:

VOV, KSL, WJJD

1140 Kilocycles, 263.0 Meters:

WAPI, KVOO

1150 Kilocycles, 260.7 Meters:

WHAM

1160 Kilocycles, 258.5 Meters:

WWVA, WOWO

1170 Kilocycles, 256.3 Meters:

WCAU, KTNT, KEJK

1180 Kilocycles, 254.1 Meters:

WGBS, KEX, KOB, WGDY, WHDI

1190 Kilocycles, 252.0 Meters:

WICC, WOAI

1200 Kilocycles, 249.9 Meters—Canadian Shared:

WABI, WNBX, WEPS, WORC, WIBX, WHBC, WLAP, WLBG, WNBO, WPRC, WKJC, WNEW, WABZ, WJBW, WBBY, WBBZ, WFBC, WRBL, KGCU, WJBC, WJBL, WWAÉ, WRAF, WMT, KFJB, WCAT, KGDY, KFWF, KFKZ, KGDE, KGFK, WCLO, WHBY, KFXM, KPCC, KXO, KSMR, WIL, KFHA, KVOS, KGY, WMAY, KWG, KGEK, KGEW, KGHI

1210 Kilocycles, 247.8 Meters—Canadian Shared:

WJBI, WGBB, WINR, WCOH, WOCL, WLCI, WPAW, WDFW, WLSI, WMAN, WJW, WEBE, WBAX, WJBU, WMBG, WSIX, WRBU, WJBY, WMBR, WRBO, WPCM, KWEA, KDLE, KGCR, KFOR, WHBU, KFVS, WEBQ, WCRW, WEDC, WCBS, WTAX, WHBF, WIBA, WOMT, KPO, KPCB, WSBC, KDFN, KMJ

1220 Kilocycles, 245.6 Meters:

WCAD, WCAE, WREN, KFKU

1230 Kilocycles, 243.8 Meters:

WNAC, WBIS, WPSC, WSBT, WFBM, KYA, KFIO

1240 Kilocycles, 241.8 Meters:

WGHP, WJAD, WQAM, WRBC, KTAT

1250 Kilocycles, 239.9 Meters:

WGCP, WODA, WAAM, WLB, WGMS, WRHM, KFMX, WCAL, KXL, KIDO, KFOX

1260 Kilocycles, 238.0 Meters:

WLBW, WJAX, KWWG, KRGV, KOIL, KVOA

1270 Kilocycles, 236.1 Meters:

WEAI, WASH, WOOD, WDSU, KWLC, KGCA, KTW, KOL, KFUM, WFBR, WJDZ

1280 Kilocycles, 234.2 Meters:

WCAM, WCAP, WOAX, WDDO, WRR, WDAY, WBCB

1290 Kilocycles, 232.4 Meters:

WNBZ, WJAS, K TSA, KFUL, KLCN, KDYL

1300 Kilocycles, 230.6 Meters:

WBBR, WHAP, WEVD, WHAZ, KFH, WIBW, KGEF, KTBI, KFJR, KTBK

1310 Kilocycles, 228.9 Meters:

WKAV, WEBR, WNBH, WOL, WGH, WRK, WAGM, WDFD, WNAT, WFKD, WHBP, WFBG, WRAW, WGAJ, WSAJ, WBRB, WMBL, WKBC, KGHG, WGBT, WNBK, KRMD, KFFM, WDAH, KFPL, KFNR, WKBS, WRBI, WEHS, WCLS, WKBB, WKBI, WHFC, KWCR, KFJY, KFGQ, WBOW, WJAK, WLRC, WIBU, KFBK, KTSJ, KGEZ, KFUP, KFXJ, KFBK, KGEZ, KMED, WJZD, KTSM, KGCX

1320 Kilocycles, 227.1 Meters:

WADC, WSMB, KID, KGIQ, KGHF

1330 Kilocycles, 225.4 Meters:

WDRG, WTAQ, KSCJ, WSAI

1340 Kilocycles, 223.7 Meters:

WSPD, KFPW, KMO, KFPY

1350 Kilocycles, 222.1 Meters:

WBNY, WMSG, WCDA, WKBQ, KWK

1360 Kilocycles, 220.4 Meters:

WLEX, WMAF, WQBC, WJKS, WGES, KFBK, KGIR, KGB

1370 Kilocycles, 218.8 Meters:

WMBQ, WSVS, WCBM, WBBL, WHBD, WJBK, WIBM, WRAK, WELK, WJBO, WHBQ, WRBT, KGFG, KIT, KGCI, KGRC, KFJZ, KGKL, KFLX, WFBJ, KGDA, KZM, KRE, KGER, KFBL, KWKC, KGBX, WRJN, KGAR, KLO, KOH, KVL, KFJL, KGFL, KGGM, WHDF, KOOS, WGL, KFJM, KCRG, WJJDW

1380 Kilocycles, 217.3 Meters:

WCSO, KQV, KSO, WKBH

1390 Kilocycles, 215.7 Meters:

WHK, KLRA, KUOA, KOW, KWSC, KOY

1400 Kilocycles, 214.2 Meters:

WCGU, WSGH, WSDA, WLTH, WBBC, WCMA, WKBF, KOCW, WBAA

1410 Kilocycles, 212.6 Meters:

KGRS, WDAG, KFLV, WHBL, WBCM, WTOC

1420 Kilocycles, 211.1 Meters:

WMRJ, WBO, WSSH, WIBR, WEDH, WMBQ, WKBQ, WQBZ, KGFF, WHIS, KTAP, KTUE, KFYO, KICK, WIAS, KGGC, WLRF, WMBH, KGFV, KFIZ, KFXV, KGFJ, KFQU, KFXD, KGIX, KFIF, KORE, KXRO, WILM, WPOE, KGIW, KGKX, WHDL, WLEY, KFQW, KLFM

1430 Kilocycles, 209.7 Meters:

WBRL, WHP, WCAH, WGBC, WNBR, WBAK

1440 Kilocycles, 208.2 Meters:

WHEC, WABO, WOKO, WCBA, WNRC, WTAD, WMBD, KLS, WSAK

1450 Kilocycles, 206.8 Meters:

WBMS, WNI, WBS, WKBO, WSAR, WFJC, WTFI, KTBS

1460 Kilocycles, 205.4 Meters:

WJSV, KSTP

1470 Kilocycles, 204.0 Meters:

WKBW, KFJF, WRUF, KGA

1480 Kilocycles, 202.6 Meters:

WJAZ, WORD, WCKY, WSOA

1490 Kilocycles, 201.6 Meters:

WBAW, WLAC, KPWF

1500 Kilocycles, 199.9 Meters:

WMBQ, WLOE, WMES, WNBK, WMBQ, WLEX, WCLB, WWRL, WKBZ, WMPG, WMBJ, WOPI, WPEN, WRBJ, KGKB, KGDR, KGHX, WKBV, KPJM, KVEP, KREG, KDB, KUJ, KGI

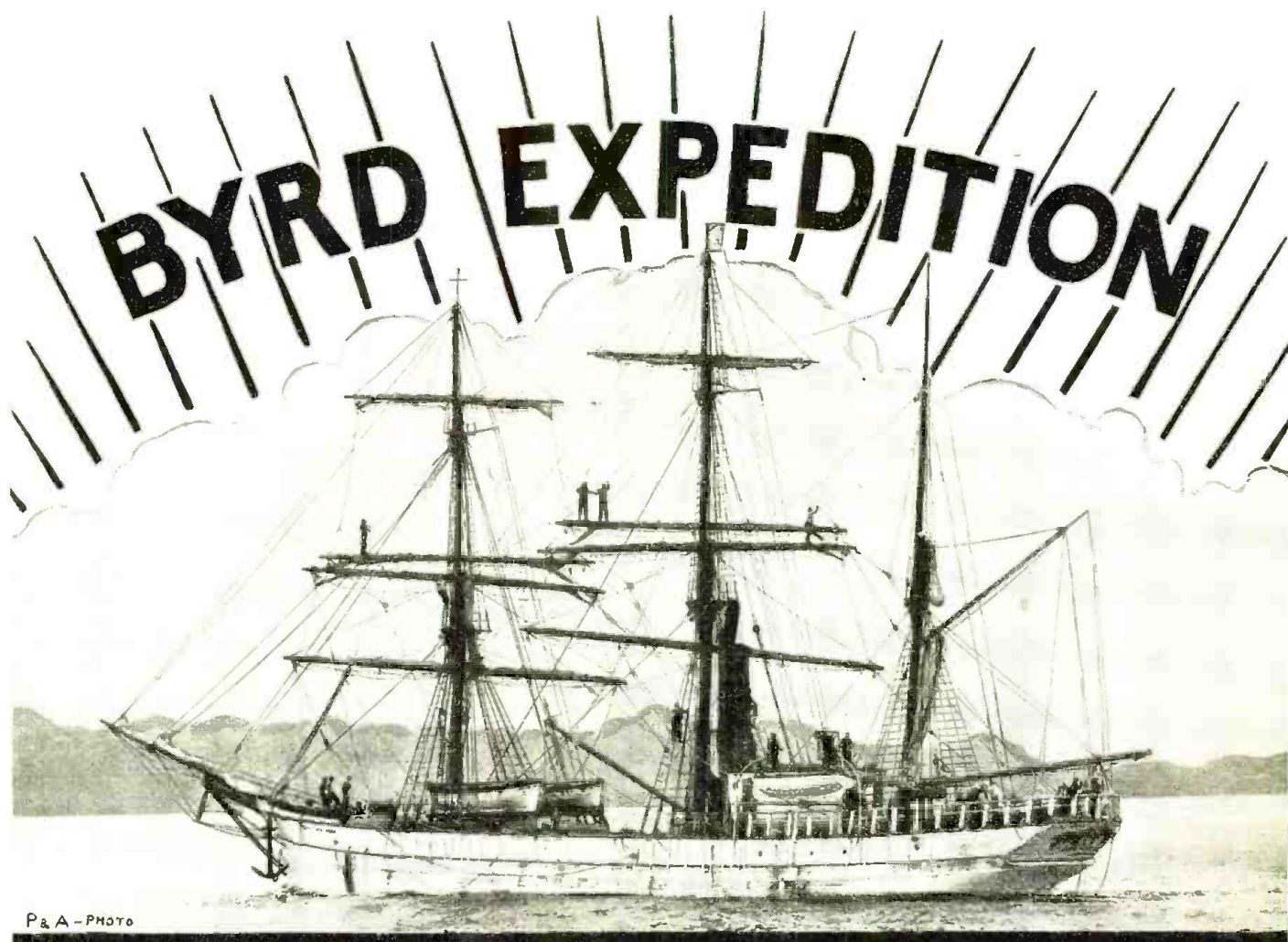

Transmitters and Receivers employ Sangamo Condensers

Away down among the ice barriers of the Antarctic . . . only the dependable operation of short wave transmitters and receivers keeps the Byrd Expedition in touch with the civilized world. Only the snappy kick of short wave equipment affords a plane in trouble the protection of the mother ship.

Not unusual then, the choice of Sangamo 5000-volt Fixed Condensers for the radio equipment. Tested at 5000 volts

d. c. and 3500 a. c. and built to the world radio-known Sangamo standard, amateurs, commercial men and manufacturers have come to rely on Sangamo High Voltage Condensers.

Accurately rated, more than adequately tested and enclosed in an impervious Bakelite molding—these condensers offer the maximum protection in high voltage, high frequency circuits.

SANGAMO ELECTRIC COMPANY
Springfield, Illinois

Sangamo Electric Company of Canada, Ltd., 183 George Street, Toronto, Ont.
Manufacturers of Precision Electrical Apparatus for 30 Years

Tell 'Em You Saw It in the Citizens Radio Call Book Magazine and Scientific Digest

U. S. Broadcasting Stations Listed by States

- ALABAMA**
Birmingham, WBRC, WKBC, WAFI
Gadsden, WJBY
- ALASKA**
Ketchikan, KGRU
- ARIZONA**
Flagstaff, KFXV
Phoenix, KPAA, KOY
Prescott, KPJY
Tucson, KCAR, KVOA
- ARKANSAS**
Blytheville, KLCN
Fayetteville, KGOA
Hot Springs, KTHS
Little Rock, KLRN, KGHJ, KGB
McGehee, KGHG
Siloam Springs, KFPW
- CALIFORNIA**
Berkeley, KRE
Beverly Hills, KEJK
Burbank, KBLW
Culver City, KFVD
El Centro, KXO
Fresno, KFI
Hayward, KZM
Hollywood, KFQZ, KMTR, KNN, KFVB
Holy City, KFQU
Inglewood, KMIC
Long Beach, KFOX, KGER
Los Angeles, KFI, KFSG, KGEF, KGFJ, KHJ, KPLA, KTTI
Oakland, KFWM, KGO, KLS, KLN, KFAB
Ontario, KFXM
Pasadena, KPTC, KPSN
Sacramento, KFHK
San Diego, KFSD, KGB
San Francisco, KFRC, KFWI, KJBS, KPQ, KGGC, KYA
San Jose, KQW
Santa Ana, KWTC
Santa Barbara, KDB
Santa Maria, KSMR
Santa Monica, KTM
Stockton, KGDH, KGW
Westminster, KPWF
- COLORADO**
Colorado Springs, KFUM
Denver, KFEL, KFUP, KFXF, KOA, KPOF
Durango, KZZ
Eggenwiler, KFJX
Fort Morgan, KGEW
Greeley, KFKA
Gunnison, KFIA
Pueblo, KGHF
Trinidad, KGIW
Yuma, KGEK
- CONNECTICUT**
Bridgeport, WICC
Hartford, WTIC
New Haven, WDRG
Storrs, WCAO
- DELAWARE**
Wilmington, WDEL, WILM
- DISTRICT OF COLUMBIA**
Washington, NAA, WMAL, WRC, WOL
- FLORIDA**
Clearwater, WFLA, WSUN
Gainesville, WRFL
Jacksonville, WJAX
Lakeland, WMBH
Miami Beach, WIOD, WQAM
Orlando, WROR
Pensacola, WCGA
Tampa, WDAE, WMBR
- GEORGIA**
Atlanta, WGST, WSB
Columbus, WRBL
Macon, WMAZ
Savannah, WTOG
Tifton, WRBI
Toccoa, WTFI
- HAWAII**
Honolulu, KGU
- IDAHO**
Boise, KIDO
Idaho Falls, KID
Jerome, KFXD
Pocatello, KSEI
Sandpoint, KOKX
Twin Falls, KGIQ
- ILLINOIS**
Carthage, WCAZ
Chicago, KTV, WAAF, WCFL, WCRW, WEDC, WENR, WGES, WKBH, WPCW, WGN, WMAQ, WMBI, WBBM, KYWA, WSBC, WBCN, WIBO, WJAZ, WJBT, WLIB, WLS, WORD, KFKX
Cicero, WHFC
Decatur, WJBL
Evanston, WEHS
Forest Park, WSOA
Galesburg, WKBS
Harrisburg, WEBQ
Joliet, WOLS, WKBB
La Salle, WJBC
Mooseheart, WJJD
Peoria Heights, WMBD
Quincy, WTAD
Rockford, KFLY
Rock Island, WHBF
Springfield, WGBS
Streator, WTAX, WTSU
Tuscola, WJZ
Urbana, WILL
Zion, WCBZ
- INDIANA**
Anderson, WHBU
Brookville, WKBY
Culver, WCMA
Evansville, WGBF
Fort Wayne, WGL, WOVO
Gary, WJKS
Hammond, WWAE
Indianapolis, WFPM, WKBF
Lafayette, WFAA
La Porte, WIAF
Marion, WJAK
Muncie, WUBT
South Bend, WSBT
Terre Haute, WBOW
Valparaiso, WRBC
- IOWA**
Ames, WOI
Boone, KFGQ
Cedar Rapids, KWCR
Clarinda, KSO
Council Bluffs, KOIL
Davenport, WOC
Decorah, KGOA, KWLO
Des Moines, WHO, Ft. Dodge, KFJY
Iowa City, WISU
Marshalltown, KFJB
Muscatine, KNTT
Ottumwa, WIAS
Red Oak, KICK
Shenandoah, KFNF, KMA
Sioux City, KSCJ
Waterloo, WMT
- KANSAS**
Kansas City, WLBF
Lawrence, KFKU, WREN
Manhattan, KSAO
Milford, KFKB
Topeka, WIBW
Wichita, KFH
- KENTUCKY**
Covington, WCKY
Hopkinsville, WFTW
Louisville, WHAS, WLAP
- LOUISIANA**
Cedar Grove, KGGH
Kennerwood, KWKH
New Orleans, WARZ, WJBO, WJBW, WSMR, WWL, WDSU
Shreveport, KTSL, KWEA, KIMD, KTBS
- MAINE**
Bangor, WABL, WLBZ
Portland, WCSH
- MARYLAND**
Baltimore, WCAO, WCBM, WBAJ, WFBR
Cumberland, WTBO
- MASSACHUSETTS**
Auburn, WORC
Boston, WBZA, WEEI, WNAC, WSSH, WMES, WBIS, Dartmouth, WMAF
Springfield, WBZ
Fall River, WSAR
Gloucester, WEPS, WHDH
Lexington, WLEX, WLEY
New Bedford, WNBH
Wellesley Hills, WBSO
Worcester, WTAG
- MICHIGAN**
Battle Creek, WKBP
Bay City, WBCM
Berrien Springs, WEMO
Calumet, WHDF
Detroit, WMBC, WWJ, WJR, WJLP
East Lansing, WKAR
Flint, WFDF
Grand Rapids, WASH, WOOD
Jackson, WIBM
Lapeer, WJPC
Ludington, WKBZ
Royal Oak, WAGM
Ypsilanti, WJBE
- MINNESOTA**
Anoka, WCCO
Collegeville, WFBJ
Duluth, WECB
Fergus Falls, KGDE
Hallock, KGFK
Minneapolis, WGDY, WHDI, WLB, WRHM, WCCO, WGS
Northfield, KFMY, WOAL
St. Paul, KSTP
- MISSISSIPPI**
Columbus, WCOG
Greenville, WRBQ
Gulfport, WCGM
Hattiesburg, WRBJ
Jackson, WJDX
Utica, WQBC
- MISSOURI**
Cape Girardeau, KFVS
Columbia, KFRU
Independence, KMBC
Jefferson City, WOS
Joplin, WMBH
Kansas City, KWKC, WDAF, WOG, WHR
Kirksville, KFYZ
St. Joseph, KGBX, KFEQ
St. Louis, KFWE, KSD, KWE, WEW, WIL, KMOX, KFQO, WMAZ, KFQA
- MONTANA**
Billings, KGHM
Butte, KGIR
Great Falls, KFBB
Kalispell, KGEZ
Missoula, KUOM
Wolf Point, KGCK
- NEBRASKA**
Clay Center, KMMJ
Lincoln, KFAB, KFOR, WOAJ
Norfolk, WJAG
Omaha, WAAW, WOW
Ravenna, KGFV
York, KGBZ
- NEVADA**
Reno, KOH
- NEW HAMPSHIRE**
Laconia, WKAJ
Tilton, WBEL
- NEW JERSEY**
Ashbury Park, WCAP
Atlantic City, WPG
Camden, WCAM
Elizabeth, WBS
Fort Lee, WBMS
Jersey City, WAAT, WKRO
Newark, WAAM, WGCP, WNJ, WOR
Paterson, WODA
Red Bank, WBI
Trenton, WOAK
- NEW MEXICO**
Albuquerque, KGGM
Las Vegas, KGIX
Raton, KGFJ
State College, KOB
- NEW YORK**
Auburn, WMBO
Bay Shore, WNR
Binghamton, WNEF
Brooklyn, WABC, WLTH, WMBQ, WSGH, WSDA
Buffalo, WFRB, WGR, WKRW, WKEN, WSVS, WMAK
Canton, WCAD
Cazenovia, WMAC
Conex Island, WCGU
Freeport, WGBE
Ithaca, WLIC, WEAJ
Jamaica, WJRA
Jamestown, WOCL
- LONG BEACH, WCLB**
Long Island City, WLBX
New York, WBNY, WHN, WJZ, WKBC, WMCA, WMSG, WNYC, WPCB, WPT, WABC, WOV, WQTA, WLWL, WBO, WQDA, WFAF, WEVD, WGSB, WHAP, WPAP
Patchogue, WPOE
Poughkeepsie, WOKO
Rochester, WHAM, WHEC
Rossville, WBBR
Saranac Lake, WNBZ
Schenectady, WGY
Syracuse, WFBI, WSYR
Troy, WHAZ
Tupper Lake, WHDL
Utica, WIPX
Woodhaven, WEVD
Woodside, WWRL
Yonkers, WCOH
- NORTH CAROLINA**
Asheville, WVNC
Charlotte, WBT
Gastonia, WRBU
Greensboro, WNRO
Raleigh, WPTF
Wilmington, WRBT
Winston-Salem, WJZD
- NORTH DAKOTA**
Bismarck, KFYZ
Devils Lake, KDLR
Fargo, WDAY
Grand Forks, KFJM
Mandan, KGCU
Minot, KLPM
- OHIO**
Akron, WADC, WFJC
Bellefontaine, WHBD
Canton, WHBC
Cincinnati, WERE, WSAI, WRCR
Cincinnati, WKRC, WLAJ
Cleveland, WEAR, WHEK, WJAY, WTAM
Columbus, WAIU, WCAH, WEAQ, WMAN
Dayton, WSMK
Hamilton, WRK
Mansfield, WJW
Middleton, WRSO
Springfield, WCSO
Steubenville, WIBR
Toledo, WSPD
Youngstown, WKBW
- OKLAHOMA**
Alva, KGFH
Chickasha, KOCW
Enid, KCRG
Norman, WNAD
Oklahoma City, KFJF, KFKB, KGCN, KGFV, WKY
Picher, KGGF
Ponca City, WBBZ
Tulsa, KVOO
- OREGON**
Astoria, KFJI
Corvallis, KOAC
Eugene, KORE
Marshfield, KOOS
Medford, KMBD
Portland, KEX, KOIN, KFJP, KFJR, KGW, KTBR, KVEP, KWJJ, KXL
- PENNSYLVANIA**
Allentown, WCBA, WSAJ
Allentown, WFBG
Carbondale, WNBW
East Pittsburgh, KDKA
Elkins Park, WIRG
Erie, WEDH, WRAK
Frankford, WFKD
Grove City, WSAJ
Harrisburg, WRAK, WPRC
Johnstown, WHBP
Lancaster, WGAL, WKJC
Le Moyne, WHP
Lewisburg, WJRU
Oil City, WLBW
Philadelphia, WCAU, WFI, WIP, WLIT, WNAT, WRAX, WPEN, WFAN, WELK
Pittsburgh, KQV, WCAE, WJAS
Reading, WRAW
Scranton, WGBL, WQAN, State College, WPSC
Wilkes-Barre, WRAX, WBRB
Wilkesburg, WMBJ
Washington, WNBO
- PORTO RICO**
San Juan, WKAQ
- RHODE ISLAND**
Cranston, WDFW
Newport, WMLA
Pawtucket, WPAW
Providence, WEAN, WJAR
- SOUTH CAROLINA**
Charleston, WBBY
- SOUTH DAKOTA**
Brookings, KFDY, KGOR
Dell Rapids, KGDA
Oldham, KGDY
Pierre, KGFX
Rapid City, WCAT
Sioux Falls, KSOO
Vermillion, KUSD
Watertown, KGRG
Yankton, WNAZ
- TENNESSEE**
Bristol, WOPI
Chattanooga, WDOD
Knoxville, WFCB, WNBZ, WNOX
Lawrenceburg, WOAN
Memphis, WGBS, WBRQ, WMC, WNNR
Nashville, WBAW, WLAC, WSM
Springfield, WSIX
Union City, WOBT
Whitehaven, WREC
- TEXAS**
Abilene, KFYO
Amarillo, KGRS, WDAG
Austin, KUT
Beaumont, KFDM
Brownsville, KWWG
Brownwood, KGBB
College Station, WTAW
Corpus Christi, KGFI
Dallas, KRLD, WFAA, WRR
Dallas, KPDL
El Paso, WDAH, KTSM
Forth Worth, KFJZ, WBAJ, KTAT
Galveston, KFLX, KFUL
Greenville, KFPM
Harlingen, KRGV
Houston, KPRC, KTUE
Richmond, KGHX
San Angelo, KGFY, KGKL
San Antonio, KGDR, KGRC, KTAP, KTSB, WOAI
Waco, WJAD
Wichita Falls, KGKO
- UTAH**
Ogden, KIO
Salt Lake City, KDYL, KSL
- VERMONT**
Springfield, WNBX
- VIRGINIA**
Arlington, NAA
Emory, WJVD
Mt. Vernon Hills, WJVS
Newport News, WGH
Norfolk, WTAR, WFOR
Petersburg, WLBG
Richmond, WBBJ, WMBG, WRVA
Roanoke, WDBJ
- WASHINGTON**
Aberdeen, KXRO
Bellingham, KVOG
Everett, KFBL
Lacey, KGY
Longview, KUJ
Pullman, KWSC
Seattle, KOM, KFQW, KPQ, KJR, KMO, KPCH, KRSC
Kennewick, KUL
Spokane, KFIO, KFPY, KGA, KHQ
Tacoma, KMO, KVI
Yakima, KIT
- WEST VIRGINIA**
Bluefield, WHIS
Charleston, WOHU
Fairmont, WJMN
Huntington, WSAZ
Wheeling, WVAZ
Martinsburg, WQZB
- WISCONSIN**
Beloit, WBER
Eau Claire, WTAQ
Fond Du Lac, KFZ
Kenosha, WGL
La Crosse, WKBH
Madison, WHA, WIRA
Manitowish, WJMT
Milwaukee, WHAD, WISN, WTMJ
Poyntette, WIRU
Racine, WRIN
Sheboygan, WHBL
Stevens Point, WLRJ
West De Pere, WBBY
- WYOMING**
Casper, KDFN



NELSON AC RECEIVER IN PALMER CONSOLE

This very attractive model appeals to those seeking for something different in a fine radio receiver. Slightly modernistic in design, it embodies good taste and graceful lines. Walnut construction throughout, with French doors of diamond matched Oriental walnut set off by carefully selected walnut panels. Equipped with large Jensen DC electro-dynamic speaker.

LIST PRICE \$185, without tubes
This receiver fully described in this issue.

The NEW Nelson AC Receiver A Masterpiece in Radio

THE new Nelson AC Receiver fully utilizes every known advance in radio science. It offers the dealer the advantage of all modern essentials of performance, construction, reliability and dependability, which few receivers on the market today can match. Employing the Selectaphase system of complete tuning under the Technidyne circuit, it gives a new meaning to **Selectivity**. The Nelson AC Receiver actually "pre-selects" the signal and filters out interference and noise before amplification begins.

Uses **nine tubes** in all, five of them in the radio frequency circuit! **Power Detection** that eliminates the noisy intermediate stage! **Push-Pull Audio**, using the new 245 type tubes! Genuine Jensen Electro-Dynamic Speaker—the big 11" size, to take the tremendous power of the highly efficient Technidyne circuit, and reproduce everything, bass or treble, music or voice, in the true, realistic tone re-created by the instrument itself. Here you have **Power . . . Range . . . Tone!**



Note These Features:

AC OPERATION

Practical AC operation assures consistent performance. Oversize air-cooled power transformer, with unique voltage control device makes for more efficient operation and longer tube life.

TIUMLESS

Use of the new A1 heater type tubes insures freedom, from hum and all extraneous noises, which in combination with DC dynamic speaker and large capacity Mershon Filter Condenser means an unusually fine quality of reproduction.

SELECTIVITY

Completely shielded four-in-line tuning condenser and scientifically accurate coils, used in a highly efficient pre-selection circuit, permits a degree of selectivity which easily separates powerful locals and brings in distant stations with the punch of a local.

SUPER-SENSITIVITY

Power detector and improved radio frequency amplifying stages completely eliminates possibility of oscillation, yet maintains 100% sensitivity. Circuit is designed to provide equal amplification over the entire waveband.

APPEARANCE

Consoles are especially designed to incorporate beauty and good taste. Only the finest hard-woods and best craftsmanship enter into their construction. Lustrous hand-rubbed finish and authentic styles fit into any decorative scheme.

DEALERS WANTED

Responsible dealers everywhere will find it to their advantage to know more about the new Nelson AC Radio. Its furniture excellence and true-tone performance makes it a self seller that stays sold. Write today for complete details and dealer's proposition. Desirable territory is still open.

NELSON ELECTRIC COMPANY

508 South Dearborn Street

Chicago, Ill.

"We Ship Faster"

PRICE

Range of prices and styles sufficient to meet with the individual taste and ideas of each user. Large scale production allows price to be kept far below that of any other receiver of equal quality and performance.

POWER DETECTION

Tuned power detector circuit operating at high efficiency, is in keeping with latest engineering practice. Due to impossibility of overloading detector circuit, more volume and purer tone are a matter of course.

"245'S IN PUSH-PULL

Two 245 super power amplifying tubes in the output stage have an output far in excess of a 250 power tube, giving an unsurpassed quality of reproduction which represents the utmost in tonal refinement.

STONE

Large oversize transformers, well designed audio and radio frequency circuits, and a large Jensen dynamic speaker, each carefully matched, all contribute to the wonderful tone quality characteristic of this fine receiver.

TREMENDOUS VOLUME

Perfection in the audio frequency amplifying stages coupled with the large undistorted output of the detector circuit makes possible an ultimate power output of auditorium volume, and from concert volume to a whisper at will.



NELSON AC-30 RECEIVER IN MORTON CONSOLE

A moderately priced console receiver in a lowboy model of distinctly beautiful and graceful lines. Finest walnut and other hardwoods used throughout. Genuine walnut burl overlay with straight grained Oriental walnut instrument panel. Carefully matched diagonal grain sliding doors. Rich hand rubbed finish that fits in any decorative scheme whatever. Equipped with large Jensen electro-dynamic speaker.

LIST PRICE \$170 without tubes

NELSON ELECTRIC COMPANY
 508 SOUTH DEARBORN STREET,
 CHICAGO, ILLINOIS.

Please send me full information regarding the New Nelson AC Receiver, together with details on Dealer Franchise, etc.

Name

Address

DEALER SERVICE MAN CUSTOM SET BUILDER

Tell 'Em You Saw It in the Citizens Radio Call Book Magazine and Scientific Digest

SHORT WAVE RELAY BROADCASTING STATIONS

Table with columns: Call, Owner, United States, Kilocycles, Meters, Call, Owner, Foreign, Kilocycles, Meters. Lists various radio stations and their technical specifications.

VISUAL BROADCASTING STATIONS

Table with columns: Call, Kilocycles, Meters, Owner, Call, Kilocycles, Meters, Owner. Lists visual broadcasting stations and their technical specifications.

FOREIGN BROADCAST STATIONS

Large table with columns: Call, Meters, Call, Meters, Call, Meters. Lists foreign broadcast stations categorized by region (e.g., Afghanistan, Albania, Argentina, Australia, etc.) and their technical specifications.

Call	Meters
CM6HS	Sagua la Grande..... 200
CM6KP	Sancti Spiritus..... 280
CM6MN	Santa Clara..... 210
CM6HS	Santa Clara..... 200
CM6WT	Santiago..... 200
CM8BY	Santiago..... 150
CM8KW	Santiago..... 250
CM6KW	Tuinucu..... 368
CURACAO	
CZECHOSLOVAKIA	
OKR	Bratislava..... 270
	Bratislava..... 300
OKB	Brno..... 342
	Kosice..... 293
	Moravska-Ostava..... 263
OKP	Praha..... 487
	Prague..... 250
DANZIG	
	Danzig..... 453
DENMARK	
	Kalundborg..... 1153.8
	Kalundborg..... 1680
	Kobenhavn..... 281
	Soro..... 1153.8
	Soro..... 1680
DOMINICAN REPUBLIC	
DUTCH EAST INDIES	
JFC	Batavia..... 220.7
ANE	Bandoeng..... 31.86
ANE	Bandoeng..... 15.93
	Bandoeng..... 310
ANI	Malabar..... 17
	Surabaya..... 140
ECUADOR	
EGYPT	
SRE	Cairo..... 255
ETHIOPIA	
ESTONIA	
	Tallinn..... 295
FINLAND	
	Helsingin..... 221
	Lahden..... 1800
	Pietarsaari..... 246
SCG	Porin..... 218
	Tampereen..... 400
	Turun..... 256
	Tammerfors..... 453
	Turku..... 246
	Viipurin..... 291
FRANCE	
PTT	Bordeaux..... 304
	Corsica..... 237
	Grenoble..... 329
	Linnos..... 293
	Lille..... 265
	Lyon..... 466
	Marseilles..... 316
	Montpellier..... 286
	Nice..... 237
FL	Paris..... 1725
	Paris..... 1444
	Paris..... 447
	Rennes..... 272
	Strasbourg..... 346
	Toulouse..... 381
	Toulousse..... 255
FRENCH COLONIES	
SDR	Algiers..... 310
SKR	Constantine..... 42.8
	Hai Phong..... 320
TJA	Tunis..... 1450
GERMANY	
	Aachen..... 453
	Augsburg..... 560
	Berlin I..... 418
	Berlin II..... 283
	Bremen..... 339
	Breslau..... 253
	Dresden..... 319
	Flensburg..... 218
	Frankfurt..... 390
	Freiburg..... 569
	Gleititz..... 325
	Hamburg..... 372
	Hannover..... 500
	Kaiserslautern..... 270
	Kassel..... 246
	Kiel..... 246
	Koln..... 227
	Konigsberg..... 276
	Konigsruherhausen..... 1635
	Langenberg..... 473
	Leipzig..... 259
	Magdeburg..... 283
	Munchen..... 533
	Munster..... 234
	Nurnberg..... 230
	Stettin..... 283
	Stuttgart..... 360
	Zeesen..... 1635
GREAT BRITAIN	
2RD	Aberdeen..... 301
2RE	Belfast..... 242
6RM	Bournemouth..... 288.5
2LS	Bradford..... 288.5
5VA	Cardiff..... 310
5GB	Darentry..... 479
5XX	Darentry..... 1553
2DE	Dundee..... 288.5
2EH	Edinburgh..... 288.5
5SC	Glasgow..... 309
6KH	Hull..... 288.5
2LS	Leeds-Bradford..... 200
6LV	Liverpool..... 288.5
2LO	London..... 356
2ZY	Manchester..... 377
5NO	Newcastle..... 261
5PY	Plymouth..... 288.5
6FL	Sheffield..... 288.5
6ST	Stoke-on-Trent..... 288.5
5SX	Swansea..... 288.5
GREECE	
GUATEMALA	
HAITI	
HHK	Port au Prince..... 361.2
HEDJAZ	
HOLLAND	
	Bloemendaal..... 200
	Hilversum..... 175
	Hilversum..... 1073
HHO	Hilversum..... 298
	Hilversum..... 298
	Huizen..... 1875
	Huizen..... 1875
	Seheveningen..... 1870

Call	Meters
HONDURAS	
HUNGARY	
	Lakihegy..... 550
ICELAND	
	Akureyri..... 192
	Reykjavik..... 192
IRAQ	
IRISH FREE STATE	
6CK	Cork..... 225
2RN	Dublin..... 413
ITALY	
1RO	Bolzano..... 445.9
1GE	Genoa..... 385.1
1MI	Milan..... 500.8
1NA	Naples..... 331.4
	Palermo..... 213
1RO	Rome..... 441.1
1TO	Torino..... 274.2
	Trieste..... 248
ITALIAN COLONIES	
JAPAN	
JOAK	Dairen..... 395
JOFK	Hiroshima..... 353
JODK	Keijo..... 366
JOGK	Kumamoto..... 380
JOCK	Nagoya..... 370
JOBK	Osaka..... 400
JOIK	Sapporo..... 361
JOIK	Sendai..... 390
JOAK	Tokyo..... 345
JUGOSLAVIA	
	Belgrade..... 420
	Ljubljano..... 566
	Zagreb..... 308
LATVIA	
YLZ	Riga..... 525
LIBERIA	
LITHUANIA	
RYK	Kaunas..... 1935
LUXEMBURG	
MEXICO	
XFF	Chihuahua..... 325
XEA	Guadalajara..... 250
XFC	Jalapa..... 475
XFC	Jalapa..... 250
XES	Lerdo..... 548.6
NEY	Merida..... 325
NEX	Mexico City..... 357
NFX	Mexico City..... 357
NEN	Mexico City..... 410
NEM	Mexico City..... 450
NEM	Mexico City..... 470
NFI	Mexico City..... 507
NFA	Mexico City..... 600-500
XEH	Monterey..... 311
XEI	Morelia..... 300
XEP	Oaxaca..... 263
XEE	Puebla..... 312
MONACO	
	Monaco..... 237
MOROCCO	
CNO	Casablanca..... 250
AIN	Casablanca..... 51
	Rabat..... 416
	Rabat..... 724.6
NEWFOUNDLAND	
NEW HEBRIDES	
NEW ZEALAND	
1ZR	Auckland..... 275.2
1ZQ	Auckland..... 252.1
1YA	Auckland..... 333.3
3ZC	Christchurch..... 250
3YA	Christchurch..... 306.1
4ZB	Dunedin..... 277.8
4Z0	Dunedin..... 277.8
4ZL	Dunedin..... 245.9
4ZM	Dunedin..... 461.5
4YA	Dunedin..... 260.9
2ZM	Gisborne..... 277.8
2ZF	Palmerston..... 285.7
2ZK	Wanganui..... 500
2YA	Wellington..... 416.7
NICARAGUA	
NORWAY	
LKA	Alesund..... 453
LKB	Bergen..... 304
LKF	Fredrikstad..... 394
LKH	Hannar..... 570
LKN	Honnalden..... 283
LKO	Lodz..... 493
LKP	Porsgrund..... 453
LKR	Rjukan..... 447
LKM	Tromso..... 453
	Trondheiu..... 1072
PANAMA	
PARAGUAY	
PERSIA	
PERU	
OAX	Lima..... 380
PHILIPPINE ISLANDS	
KZIB	Manila..... 260
KZKZ	Manila..... 270.3
KZRM	Manila..... 413
POLAND	
	Krakow..... 313
	Krakow..... 244
	Katowitz..... 408
	Lodz..... 234
	Lodz..... 335
	Poznan..... 335
	Warszawa..... 214
	Warszawa..... 1411
	Wilno..... 385.1
PORTUGAL	
PIAA	Lisbon..... 305
PORTUGUESE COLONIES	
ROUMANIA	
	Bucharest..... 394
	Bucharest..... 226
	Jassy..... 211
SAAR TERRITORY	
SALVADOR	
AQM	Salvador..... 482
SIAM	

Call	Meters
SPAIN	
EAI18	Almeria..... 251
EAI13	Barcelona..... 462
EAI1	Barcelona..... 344.8
EAI12	Barcelona..... 268
EAI9	Bilbao..... 434.8
EAI3	Cadiz..... 400
EAI16	Cartagena..... 216
EAI5	Las Palmas..... 250
EAI5	Las Palmas..... 350
EAI7	Madrid..... 375
EAI2	Madrid..... 424
EAI25	Malaga..... 100
EAI19	Oviedo..... 268
EAI27	Salamanca..... 453
EAI8	San Sebastian..... 349
EAI17	Seville..... 368
SURINAM	
SWEDEN	
SRE	Roden..... 1200
SCA	Boras..... 231
SCB	Eskilstuna..... 246
SCC	Falun..... 322
SCD	Gavle..... 204.1
SRB	Goteborg..... 322
SCE	Halmstad..... 216
SCG	Halsingborg..... 231
SCH	Horby..... 257
SCI	Indeksvall..... 270
SCI	Jonkoping..... 202
SCI	Kalmar..... 246
SCJ	Karlskrona..... 196
SCK	Karlstad..... 218
SCL	Kiruna..... 246
SCM	Kristinehamn..... 203
SCN	Malmberget..... 436
SCB	Malmo..... 231
SCO	Motala..... 1348
SCV	Norrkopung..... 270
SCW	Orebro..... 237
SBF	Ornskoldsvik..... 218
SCP	Ostersund..... 770
SCP	Saflie..... 246
SBA	Stockholm..... 436
SBD	Sundsvall..... 542
SCQ	Trollhattan..... 270
SCR	Uddevalva..... 283
SCS	Umea..... 231
SCT	Uppsala..... 453
SCU	Varborg..... 283
SWITZERLAND	
HB3	Bale..... 1010
	Berne..... 403
	Geneva..... 760
	Lausanne..... 680
HBZ	Zurich..... 459
TURKEY	
	Angora..... 1806
	Osmanieh..... 1200
	Stamboul..... 1200
UNION OF SOVIET SOCIALIST REPUBLICS	
RA47	Archangel..... 511
RA56	Artemovsk..... 720
RA26	Astrakhan..... 700
RA45	Baku..... 750
RA8	Bogorodsk..... 750
RA30	Dnepropetrovsk..... 383
RA49	Eriwan..... 1050
RA39	Gomel..... 483
RA57	Irkutsk..... 1100
RA7	Ivanovo-Voznesensk..... 337
RA43	Khar'kov..... 1304
RA45	Khar'kov..... 800
RA45	Konark..... 401
RA34	Krasnodar..... 513
RA38	Kliarhor..... 427
RA59	Leninrad..... 351
RA42	Leninrad..... 1000
RA18	Minsk..... 700
	Moscow..... 938
	Moscow..... 825
	Moscow..... 497
RA2	Moscow..... 450
RA4	Moscow..... 450
RA1	Moscow..... 1581
RA7	Nalchik..... 1075
RA13	Nizhni-Novgorod..... 840
RA32	Novorossisk..... 1117
	Nikolaev..... 366
RA40	Odessa..... 411
RA25	Orenburg..... 640
RA64	Petropavlovsk..... 778
RA46	Petrozavodsk..... 765
RA14	Rostov-on-Don..... 820
RA22	Samara..... 800
RA32	Saravov..... 420
RA9	Sevastopol..... 900
	Simferopol..... 476
RA68	Smolensk..... 330
RA72	Smolensk..... 150
	Smolensk..... 565
RA77	Stalino..... 730
RA20	Stavropol..... 550
RA15	Sverilovsk..... 1050
RA27	Tashkent..... 715
RA11	Tiflis..... 370
RA21	Tomsk..... 300
RA44	Tyer..... 370
RA51	Ulyanovsk..... 500
RA16	Vel Ustjuk..... 650
RA17	Vladivostok..... 480
RA41	Vologda..... 875
RA12	Vorenezh..... 950
URUGUAY	
CWOA	Montevideo..... 428.4
CWOH	Montevideo..... 300
CWOO	Montevideo..... 294.1
CWOR	Montevideo..... 391.6
CWOS	Montevideo..... 380
CWSC	Montevideo..... 250
CWOW	Montevideo..... 277.8
CWOW	Montevideo..... 290
CWOW	Montevideo..... 450
CWSI	Montevideo..... 268
CWOS	Salto..... 246
CWOJ	Salto..... 250
UNION OF SOUTH AFRICA	
ZTC	Capetown..... 372
ZTD	Durban..... 398
ZTJ	Johannesburg..... 443.5
ZTJ	Johannesburg..... 32
ZTJ	Pretoria..... 323
VENEZUELA	
AYRE	Caracas..... 375

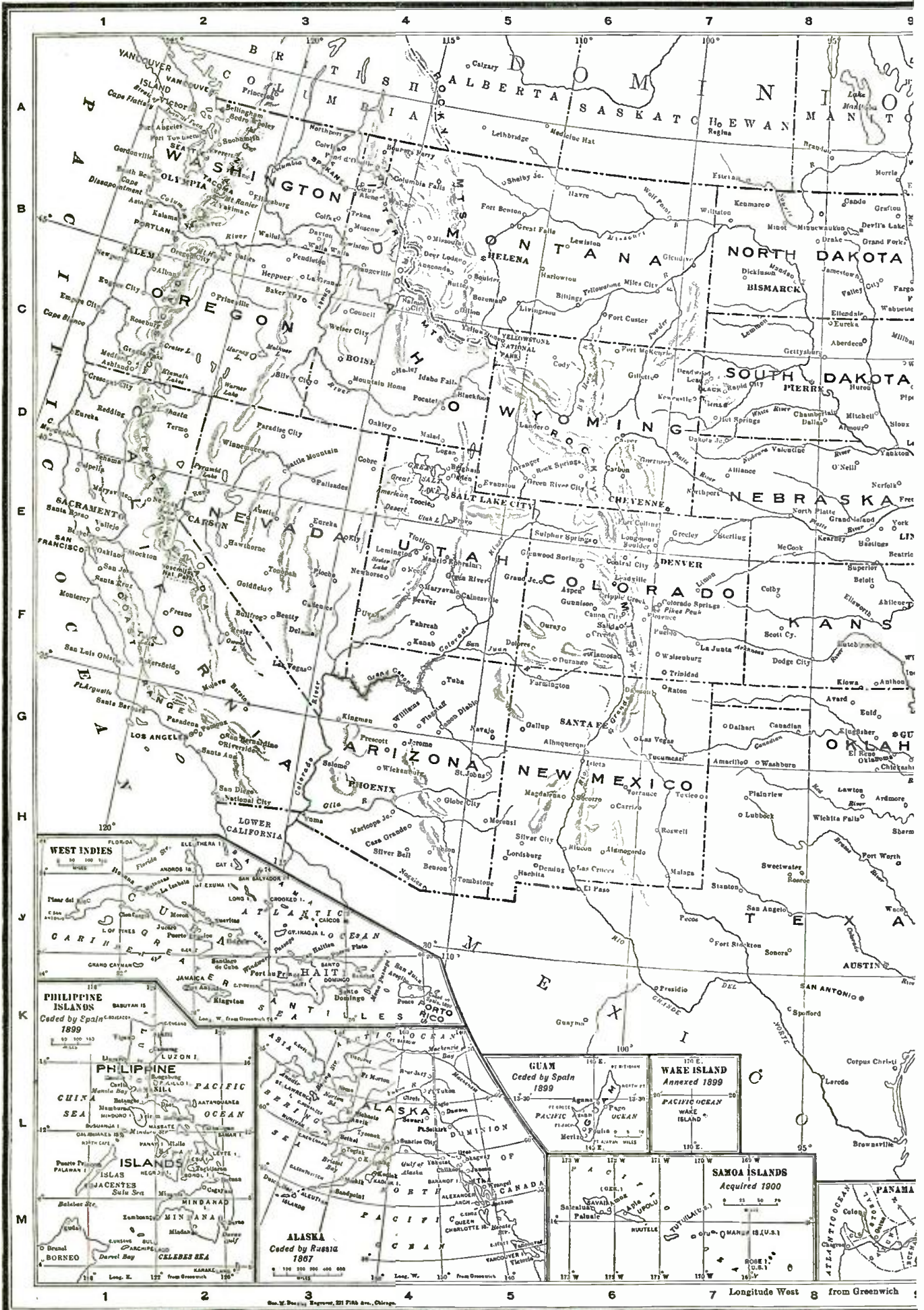

AIR-LINE DISTANCES IN STATUTE MILES

FROM/TO	Albuquerque, N. Mex.	Atlanta, Ga.	Baltimore, Md.	Boise, Idaho	Boston, Mass.	Brownsville, Tex.	Buffalo, N. Y.	Chicago, Ill.	Cincinnati, Ohio	Cleveland, Ohio	Denver, Colo.	Des Moines, Iowa	Detroit, Mich.	El Paso, Tex.	Fargo, N. Dak.	Fort Worth, Tex.	Galveston, Tex.	Hastings, Nebr.	Hot Springs, Ark.	Houghton, Mich.	Jacksonville, Fla.	Kansas City, Mo.	Los Angeles, Calif.	Louisville, Ky.	Memphis, Tenn.
Albuquerque, N. Mex.	1273	1273	1670	774	1967	838	1577	1126	1248	1417	332	833	1360	228	968	561	803	588	773	1252	1492	717	663	1174	938
Atlanta, Ga.	1273	1273	575	1830	933	960	695	583	368	550	1208	738	595	1293	1112	750	688	901	498	947	286	675	1935	317	335
Baltimore, Md.	1670	575	1670	2055	358	1525	273	603	423	305	1505	913	398	1750	1143	1239	1245	1154	964	808	682	962	2313	498	792
Boise, Idaho	774	1830	2055	2266	2266	1610	1872	1453	1663	1754	637	1155	1671	969	975	1263	1538	934	1384	1367	2098	1158	663	1623	1506
Boston, Mass.	1967	933	358	2266	2266	1881	398	849	737	550	1766	1159	613	2067	1304	1574	1598	1415	1302	922	1015	1250	2590	823	1133
Brownsville, Tex.	838	960	1525	1610	1881	1881	1575	1234	1184	1402	1047	1102	1398	682	1445	471	287	1013	650	1543	1025	923	1370	1093	777
Buffalo, N. Y.	1577	695	273	1872	398	1575	454	392	175	175	1368	762	218	1690	923	1221	1289	1019	956	560	880	862	2195	483	802
Chicago, Ill.	1126	583	603	1453	849	1234	583	454	307	307	918	310	236	1249	571	820	954	566	585	367	861	413	1741	268	481
Cincinnati, Ohio	1248	368	423	1663	737	1184	392	249	218	218	1090	509	234	1333	818	839	897	742	569	589	628	541	1892	92	410
Cleveland, Ohio	1417	550	305	1754	550	1402	175	218	218	218	1223	617	94	1521	838	1046	1116	871	797	518	768	700	2044	309	627
Denver, Colo.	332	1208	1505	637	1766	1047	1368	918	1090	1223	607	1153	554	642	642	643	925	353	749	970	1468	555	828	1035	878
Des Moines, Iowa	833	738	913	1155	1159	1102	762	310	509	617	607	545	980	397	397	640	851	256	488	458	1024	180	1433	477	485
Detroit, Mich.	1360	595	398	1671	613	1398	218	236	234	94	1153	545	1475	745	745	1018	1111	800	761	427	832	643	1976	315	621
El Paso, Tex.	228	1293	1750	969	2067	682	1690	1249	1333	1521	554	980	1475	1161	1161	543	723	757	802	1422	1481	836	702	1253	978
Fargo, N. Dak.	968	1112	1143	975	1304	1445	923	571	818	838	642	397	745	1161	1161	973	1218	440	875	393	1400	548	1426	818	882
Fort Worth, Tex.	561	750	1239	1263	1574	471	1221	820	839	1046	643	640	1018	543	973	283	283	544	273	1093	943	460	1212	751	448
Galveston, Tex.	803	688	1245	1538	1598	287	1289	954	897	1116	925	851	1111	723	1218	283	808	375	1277	799	1799	677	1423	807	492
Hastings, Nebr.	588	901	1154	934	1415	1013	1019	566	742	871	353	256	800	757	440	544	808	513	666	666	1178	226	1177	693	591
Hot Springs, Ark.	773	498	964	1384	1302	650	956	585	569	787	749	488	761	802	875	273	375	513	901	901	728	326	1437	480	176
Houghton, Mich.	1252	947	808	1367	922	1543	560	367	589	518	970	458	427	1422	393	1093	1277	666	901	901	1216	633	1787	636	830
Jacksonville, Fla.	1492	286	682	2098	1015	1025	880	861	628	768	1468	1024	832	1481	1400	943	799	1178	728	1216	943	952	2153	595	591
Kansas City, Mo.	717	675	962	1158	1250	923	862	413	541	700	555	180	643	836	548	460	677	226	326	633	952	1352	480	370	370
Los Angeles, Calif.	663	1935	2313	663	2590	1370	2195	1741	1892	2044	828	1433	1976	702	1426	1212	1423	1177	1437	1787	2153	1352	1825	1602	1602
Louisville, Ky.	1174	317	498	1623	823	1093	483	268	92	309	1035	477	315	1253	818	751	807	693	480	636	595	480	1825	319	319
Memphis, Tenn.	938	335	792	1506	1133	777	802	481	410	627	878	485	621	978	882	448	492	591	176	830	591	370	1602	319	319
Miami, Fla.	1810	747	170	2153	188	1695	291	711	568	404	1628	1023	483	1902	1213	1398	1415	1275	1125	849	838	1097	2446	650	953
Minneapolis, Minn.	980	905	948	1140	1125	1335	733	356	603	632	699	235	542	1156	219	870	1087	399	922	272	1192	413	1522	605	700
Missoula, Mont.	895	1790	1947	252	2124	1706	1740	1348	1578	1640	670	1074	1552	1115	819	1312	1595	891	1385	1208	2070	1117	910	1550	1483
Nashville, Tenn.	1117	218	597	1631	941	952	626	394	239	456	1018	523	468	1169	900	643	666	697	370	760	502	472	1777	153	195
New Orleans, La.	1030	427	1001	1713	1359	536	1087	831	708	922	1079	825	938	986	1221	470	288	870	358	1187	511	678	1675	623	358
New York, N. Y.	1810	747	170	2153	188	1695	291	711	568	404	1628	1023	483	1902	1213	1398	1415	1275	1125	849	838	1097	2446	650	953
Norfolk, Va.	1696	507	167	2137	467	1465	435	696	474	429	1562	983	522	1755	1258	1226	1195	1216	955	946	548	1009	2352	528	778
Oklahoma, Okla.	518	753	1173	1138	1490	659	1117	689	755	946	503	469	905	578	786	188	456	357	260	926	988	293	1182	675	422
Omaha, Nebr.	718	815	1026	1044	1280	1061	883	432	620	738	485	122	666	875	390	590	828	135	490	547	1098	165	1312	579	529
Philadelphia, Pa.	1748	663	90	2113	268	1614	278	664	501	343	1575	972	444	1834	1186	1324	1335	1222	1051	827	758	1037	2388	580	878
Phoenix, Ariz.	330	1592	2002	733	2295	1023	1904	1451	1578	1745	585	1154	1685	347	1225	858	1065	901	1094	1550	1800	1045	357	1512	1264
Pittsburgh, Pa.	1498	520	194	1863	478	1424	178	411	258	115	1320	718	208	1592	952	1097	1140	967	825	630	703	784	2135	345	660
Portland, Me.	2015	1022	446	2282	100	1961	438	892	802	603	1803	1197	657	2126	1313	1642	1678	1454	1371	924	1113	1300	2631	892	1205
Portland, Ore.	1107	2172	2367	349	2553	1944	2167	1765	1987	2063	985	1479	1975	1286	1248	1612	1885	1271	1733	1638	2442	1397	825	1953	1852
Richmond, Va.	1628	470	128	2060	471	1428	375	618	399	353	1488	905	445	1695	1180	1170	1154	1142	897	870	953	937	2283	457	722
St. Louis, Mo.	938	467	731	1389	1036	975	662	259	308	490	793	270	452	1033	658	568	697	455	325	591	755	238	1585	242	242
Salt Lake City, Utah	483	1580	1858	292	2099	1317	1701	1260	1450	1567	372	952	1490	689	865	977	1249	708	1116	1242	1840	922	577	1400	1250
San Francisco, Calif.	893	2133	2451	516	2696	1675	2298	1855	2037	2163	946	1547	2087	993	1447	1454	1693	1297	1648	1833	2375	1500	345	1983	1800
Schenectady, N. Y.	1823	840	278	2120	150	1770	249	702	605	408	1618	1012	467	1930	1157	1445	1487	1267	1175	776	960	1107	2445	695	1010
Seattle, Wash.	1178	2180	2341	405	2508	2015	2130	1743	1974	2035	1020	1470	1945	1373	1206	1658	1938	1288	1759	1588	2450	1505	956	1945	1867
Shreveport, La.	764	548	1064	1433	1410	510	1080	725	688	904	799	624	891	752	1002	209	253	615	142	1043	733	326	1420	598	279
Spokane, Wash.	1028	1960	2110	290	2279	1852	1900	1514	1746	1804	827	1243	1715	1238	976	1470	1753	1061	1552	1360	2239	1286	939	1720	1652
Springfield, Mass.	1889	863	282																						

AIR-LINE DISTANCES IN STATUTE MILES

FROM/TO	Miami, Fla.	Minneapolis, Minn.	Missoula, Mont.	Nashville, Tenn.	New Orleans, La.	New York, N. Y.	Norfolk, Va.	Oklahoma, Okla.	Omaha, Nebr.	Philadelphia, Pa.	Phoenix, Ariz.	Pittsburgh, Pa.	Portland, Me.	Portland, Ore.	Richmond, Va.	St. Louis, Mo.	Salt Lake City, Utah	San Francisco, Calif.	Schenectady, N. Y.	Seattle, Wash.	Shreveport, La.	Spokane, Wash.	Springfield, Mass.	Vermillion, S. Dak.	Washington, D. C.
Albuquerque, N. Mex.	1710	980	895	1117	1030	1810	1696	518	718	1748	330	1498	2015	1107	1628	938	483	893	1823	1178	764	1028	1889	742	1648
Atlanta, Ga.	610	905	1790	218	427	747	507	753	815	663	1592	520	1022	2172	470	467	1580	2133	840	2180	548	1960	863	917	542
Baltimore, Md.	958	948	1947	597	1001	170	167	1173	1026	90	2202	194	446	2367	128	731	1858	2451	278	2341	1064	2110	282	1083	33
Boise, Idaho	2368	1140	252	1631	1713	2153	2137	1138	1044	2113	733	1863	2282	349	2060	1389	292	516	2120	405	1433	290	2196	973	2045
Boston, Mass.	1258	1125	2124	941	1359	188	467	1490	1280	268	2295	478	100	2553	471	1036	2099	2696	150	2508	1410	2279	79	1314	392
Brownsville, Tex.	1100	1335	1706	952	536	1695	1465	659	1061	1614	1023	1424	1961	1944	1428	975	1317	1675	1770	2015	510	1852	1805	1161	1493
Buffalo, N. Y.	1184	733	1740	626	1087	291	435	1117	883	278	1904	178	438	2167	375	662	1701	2298	249	2130	1080	1900	325	916	290
Chicago, Ill.	1190	356	1348	394	831	711	696	689	432	664	1451	411	892	1765	618	250	1260	1855	702	1743	725	1514	774	479	591
Cincinnati, Ohio	957	603	1578	239	708	568	474	755	620	501	1578	258	802	1987	399	308	1450	2037	605	1974	688	1746	659	694	403
Cleveland, Ohio	1088	632	1640	456	922	404	429	946	738	343	1745	115	603	2063	353	490	1567	2163	408	2035	709	1804	473	785	303
Denver, Colo.	1732	699	670	1018	1079	1628	1562	903	485	1575	585	1320	1803	985	1488	793	372	946	1618	1020	909	827	1692	468	1490
Des Moines, Iowa	1338	235	1074	523	825	1023	983	469	122	972	1154	718	1197	1479	905	270	952	1547	1012	1470	624	1243	1085	187	895
Detroit, Mich.	1156	542	1552	468	938	483	522	905	666	444	1685	208	657	1975	445	452	1490	2087	467	1945	891	1715	540	705	397
El Paso, Tex.	1662	1156	1115	1169	986	1902	1755	578	875	1834	347	1592	2126	1286	1695	1033	689	993	1930	1373	752	1238	1990	920	1726
Fargo, N. Dak.	1721	219	819	900	1221	1213	1258	786	390	1186	1225	952	1313	1248	1180	658	865	1447	1157	1206	1002	976	1240	284	1141
Fort Worth, Tex.	1150	870	1312	643	470	1398	1226	188	590	1324	858	1097	1642	1612	1170	568	977	1454	1445	1658	209	1470	1495	689	1210
Galveston, Tex.	941	1087	1595	666	288	1415	1195	456	828	1335	1065	1140	1678	1885	1154	697	1249	1693	1487	1938	233	1753	1524	938	1214
Hastings, Nebr.	1468	399	891	697	870	1275	1216	357	135	1222	901	967	1454	1271	1142	455	708	1297	1267	1288	615	1061	1340	167	1139
Hot Springs, Ark.	983	722	1385	370	358	1125	955	260	490	1051	1094	825	1371	1733	897	325	1116	1648	1175	1759	142	1552	1224	605	936
Houghton, Mich.	1545	272	1208	760	1187	849	946	926	547	827	1550	630	924	1638	870	591	1242	1833	776	1588	1043	1360	860	510	813
Jacksonville, Fla.	328	1192	2070	502	511	838	548	988	1098	758	1800	703	1113	2442	953	755	1840	2375	960	2450	733	2239	957	1203	647
Kansas City, Mo.	1247	413	1117	472	678	1097	1009	293	165	1037	1045	784	1300	1397	937	238	922	1500	1107	1505	326	1286	1173	280	943
Los Angeles, Calif.	2355	1522	910	1777	1675	2446	2352	1182	1312	2388	357	2135	2631	825	2283	1585	577	345	2445	956	1457	170	2060	887	1940
Louisville, Ky.	923	605	1550	153	623	650	528	675	579	580	1512	345	892	1953	457	242	1400	1983	695	1945	598	1720	745	663	473
Memphis, Tenn.	878	700	1483	195	358	953	778	422	529	878	1264	660	1205	1852	722	242	1250	1800	1010	1867	279	1652	1055	642	763
Miami, Fla.	1095	1019	2359	821	681	1095	802	1233	1402	1023	1998	1014	1357	2716	831	1067	2098	2603	1229	2740	950	2528	1210	1510	927
Minneapolis, Minn.	1516	1010	1010	695	1050	1019	1047	692	291	985	1279	745	1145	1435	968	464	988	1585	925	1403	859	1173	1056	238	936
Missoula, Mont.	2359	1010	1010	1582	1733	2030	2045	1162	978	1997	932	1754	2133	430	1967	1331	435	762	1978	395	1457	170	2060	887	1940
Nashville, Tenn.	821	695	1582	470	470	758	586	602	604	683	1445	472	1015	1970	526	253	1390	1958	820	1973	470	1752	863	704	567
New Orleans, La.	681	1050	1733	470	470	1173	932	575	845	1090	1318	923	1445	2063	899	599	1433	1923	1259	2098	280	1898	1287	960	968
New York, N. Y.	1095	1019	2030	758	1173	1173	293	1324	1144	83	2142	313	277	2455	287	873	1972	2568	142	2419	1230	2190	120	1189	204
Norfolk, Va.	802	1047	2045	586	932	293	1186	1186	1095	220	2027	316	565	2458	79	771	1925	2510	426	2440	1037	2211	411	1166	145
Oklahoma, Okla.	1233	692	1162	602	575	1324	1186	405	405	1256	843	1013	1550	1488	1122	456	862	1386	1354	1523	297	1324	1412	502	1150
Omaha, Nebr.	1402	291	978	604	845	1144	1095	405	1094	1094	1032	837	1318	1373	1020	352	833	1425	1133	1372	617	1149	1205	115	1012
Philadelphia, Pa.	1023	985	1997	683	1090	83	220	1256	1094	1094	2079	254	360	2419	205	808	1923	2518	205	2388	1153	2159	201	1143	122
Phoenix, Ariz.	1998	1279	932	1445	1318	2142	2027	843	1032	2079	1829	2345	1007	1960	1960	1270	504	652	2152	1112	1067	1020	2220	1043	1980
Pittsburgh, Pa.	1014	745	1754	472	923	313	316	1013	837	254	1829	545	2174	242	699	561	1670	2264	350	2145	939	1918	400	891	188
Portland, Me.	1357	1145	2133	1015	1445	277	565	1550	1318	360	2345	545	2563	565	680	1094	2127	2725	197	2513	1484	2285	159	1345	480
Portland, Ore.	2716	1435	430	1970	2063	2455	2458	1488	1373	2419	1007	2174	2563	2381	2381	1723	636	536	2405	143	1783	295	2488	1293	2360
Richmond, Va.	831	968	1967	526	899	287	79	1122	1020	205	1960	242	565	2381	2381	699	1850	2436	406	2362	985	2133	407	1089	96
St. Louis, Mo.	1067	464	1331	253	599	873	771	456	352	808	1270	561	1094	1723	699	1158	1158	1738	898	1722	466	1500	958	450	710
Salt Lake City, Utah	2098	988	435	1390	1433	1972	1925	862	833	1923	504	1670	2127	636	1850	1158	1158	1738	898	1722	1155	548	2027	785	1845
San Francisco, Calif.	2603	1585	762	1958	1933	2568	2510	1386	1425	2518	652	2264	2725	536	2436	1738	582	2548	2548	680	1655	730	2625	1383	2437
Schenectady, N. Y.	1229	975	1978	820	1259	142	426	1354	1133	205	2152	350	197	2405	406	989	1950	2548	2363	2363	1290	2139	86	1165	313
Seattle, Wash.	2740	1403	395	1973	2098	2419	2440	1523	1372	2388	1112	2145	2513	143	2362	1722	697	680	2363	2363	1820	229	2445	1282	2335
Shreveport, La.	950	859	1457	470	280	1230	1037	297	147	1153	1067	939	1484	1783	985	466	1155	1655	1290	1820	1621	1333	726	1035	1035
Spokane, Wash.	2528	1173	170	1752	1898	2190	2211	1324	1149	2159	1020	1918	2285	295	2133	1500	548	73							

KC	Meters	STATIONS	DIALS		KC	Meters	STATIONS	DIALS	
			1	2				1	2
1500	199.9				1020	293.9			
1490	201.2				1010	296.9			
1480	202.6				1000	299.8			
1470	204.0				990	302.8			
1460	205.4				980	305.9			
1450	206.8				970	309.1			
1440	208.2				960	312.3			
1430	209.7				950	315.6			
1420	211.1				940	319.0			
1410	212.6				930	322.4			
1400	214.2				920	325.9			
1390	215.7				910	329.5			
1380	217.3				900	333.1			
1370	218.8				890	336.9			
1360	220.4				880	340.7			
1350	222.1				870	344.6			
1340	223.7				860	348.6			
1330	225.4				850	352.7			
1320	227.1				840	356.9			
1310	228.9				830	361.2			
1300	230.6				820	365.6			
1290	232.4				810	370.2			
1280	234.2				800	374.8			
1270	236.1				790	379.5			
1260	238.0				780	384.4			
1250	239.9				770	389.4			
1240	241.8				760	394.5			
1230	243.8				750	399.8			
1220	245.8				740	405.2			
1210	247.8				730	410.7			
1200	249.9				720	416.4			
1190	252.0				710	422.3			
1180	254.1				700	428.3			
1170	256.3				690	434.5			
1160	258.5				680	440.9			
1150	260.7				670	447.5			
1140	263.0				660	454.3			
1130	265.3				650	461.3			
1120	267.7				640	468.5			
1110	270.1				630	475.9			
1100	272.6				620	483.6			
1090	275.1				610	491.5			
1080	277.6				600	499.7			
1070	280.2				590	508.2			
1060	282.8				580	516.9			
1050	285.5				570	526.0			
1040	288.3				560	535.4			
1030	291.1				550	545.1			

The *NEW* BRAXTON-KING RECEIVER

A.C. SCREEN GRID SUPERHETERODYNE

QUALITY

*Far Above
the Ordinary*

The new Braxton-King has a fineness of detail, workmanship and appearance that stamps it as an outstanding example of precision radio design.

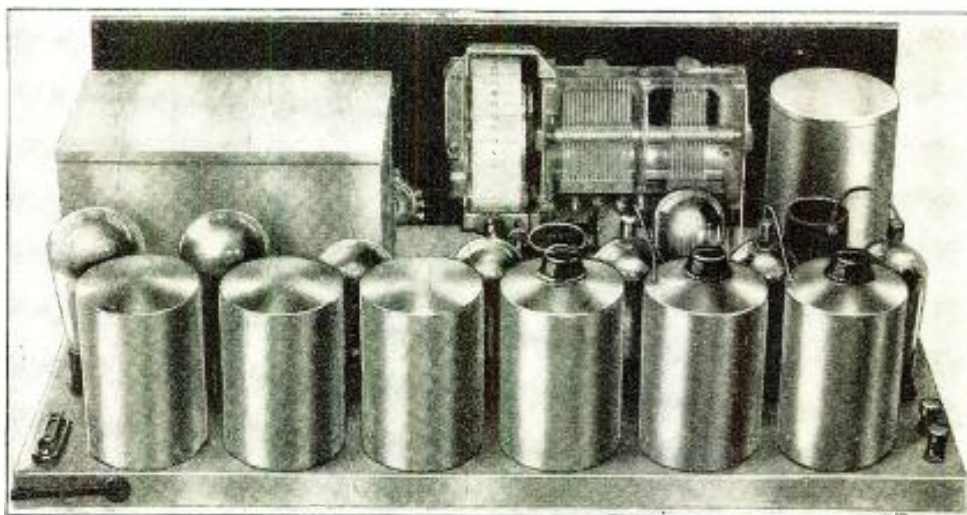

MODEL "A"

Realizing the demand for an A. C. Screen Grid Superheterodyne Tuner unit, we are also producing the Braxton-King Model B. This Tuner is exactly similar in every detail to our Model A with the exception that no power supply or audio amplification is included. It is designed to be used in connection with any standard power amplifier, giving, at moderate cost, a highly efficient one-dial A. C. Superheterodyne.

Price, completely wired.....\$75.00



MODEL B

IN every respect this new Braxton-King is a receiver of extraordinary quality. Two years of continuous work on the Screen Grid Superheterodynes are behind the design—and it has been built to incorporate every advantage that we have found desirable.

One dial, of course—one spot reception—power detection—and push-pull 245's, but of even more importance is the precision intermediate amplifying system with tunable transformers for exact matching and special design for high selectivity and amplification. This perfected intermediate system employs the A. C. Screen Grid tubes at their full effectiveness, building up a tremendous amplification of the incoming signal and providing sensitivity and selectivity of an unusual degree.

In point of detail the Braxton-King is probably unique among radio receivers. Every unit entering into the construction has been chosen because it was the most efficient unit to use, and each receiver is built not as a production problem but as an individual accurate assembly of perfectly matched parts that will function permanently at maximum efficiency.

The Braxton-King is complete, needing no external power supply or audio amplification. It is shipped completely wired and assembled and ready for immediate operation.

Price, completely wired, \$135.00

SET BUILDERS: Regular Set Builders' discount applies on the new Braxton-King Models.

Clip, fill in and mail this coupon. It will bring you complete information and circuit diagram of the new Braxton-King AC Screen Grid Superheterodyne.

Mississippi Valley Radio Company,
914 Pine Street, St. Louis, Mo.

Name.....

Street.....

Town..... State.....

Tell 'Em You Saw It in the Citizens Radio Call Book Magazine and Scientific Digest

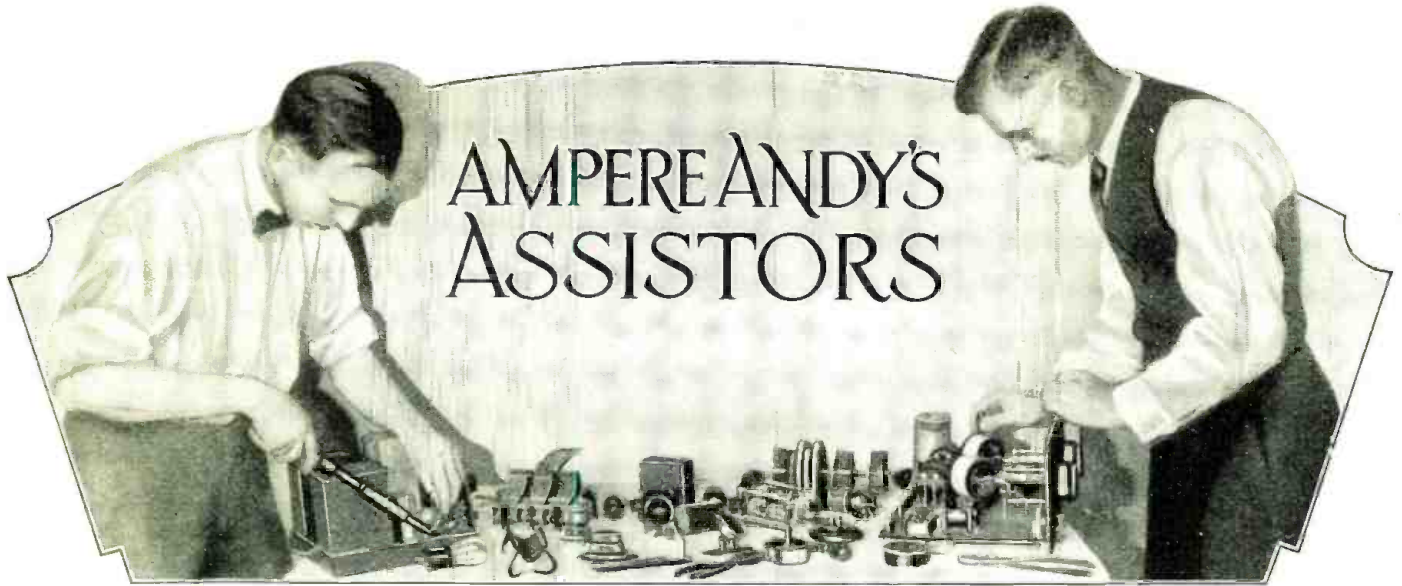

Increasing Rectifier Output by Paralleling Tubes

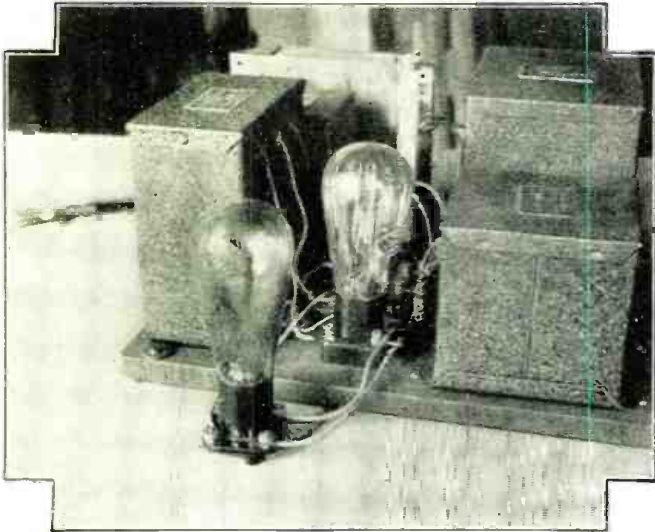

When using a power supply that employs a single 280 rectifier tube there are occasions when it may be desired to increase the current and voltage output of the power supply temporarily. This may be done by taking an extra socket and paralleling the filament by means of flexible wires to the added socket which rests at one side of the power supply and also paralleling the two plates of the 280 rectifier tube. This will give an increased current output of the power supply but is only a temporary expedient. There are other occasions when if the rectifier tube decreases in efficiency, it may be advisable to take another 280 tube which previous experience has shown to be deficient and utilize two of them in parallel until a new rectifier can be purchased.

Plug-In Meter May Be Used to Indicate Line Voltage

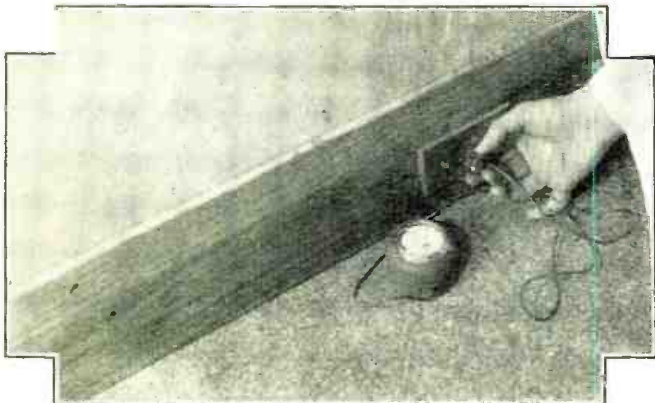

So far no manufacturer of electric radio sets has included an alternating current line meter so that the user may know at all times the

voltage of his supply line. However, in the absence of such a meter on the set many individuals have found it profitable to secure a small 0 to 150 a. c. voltmeter which may be plugged into the wall socket to determine the actual line voltage before setting the voltage control on the receiver. Most of the present day receivers have a voltage control on the power supply so that the unit may be used with a voltage lower or a voltage higher than the usual 110. If one has such a plug-in meter and desires to keep it in the circuit all the time, he may do so by getting a double socket, plugging his power supply into one outlet and the a. c. voltmeter into the other.

Electrostatic Field From Rectifier May Put Hum in Set

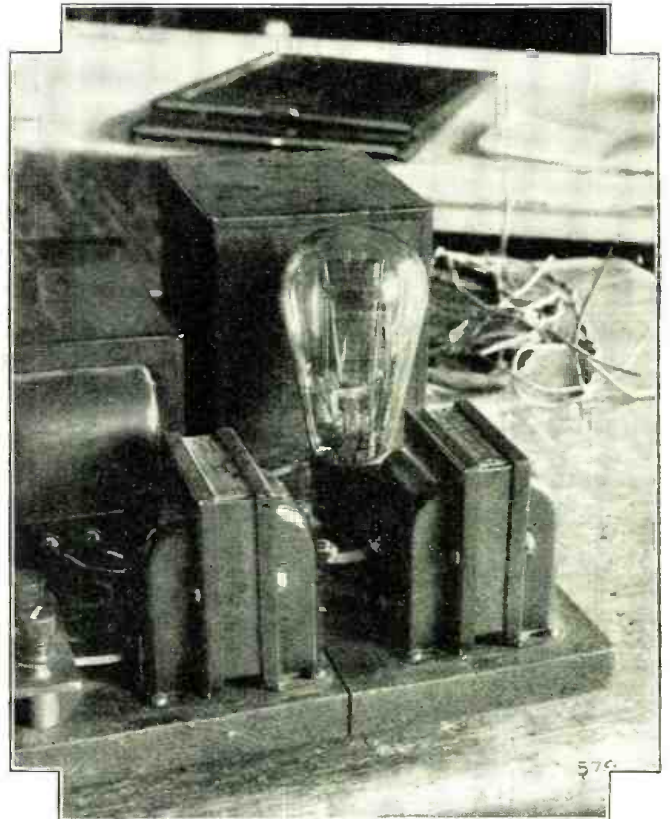

This photograph illustrates very clearly how a rectifier tube should not be placed in building a set. The transformer at the right in the illustration is the first audio transformer and it is located within the electrostatic field of the rectifier which often produces a hum in the receiver. It would have been much better practice to have located the rectifier tube in some other position than the one shown above. This condition does not exist as frequently when the chassis form of construction is used, because under those conditions the rectifier tube is on top of the sub-panel, whereas the audio transformers are usually below and, therefore, out of the electrostatic field.

Insulating Material Used to Damp Out Cabinet Vibrations

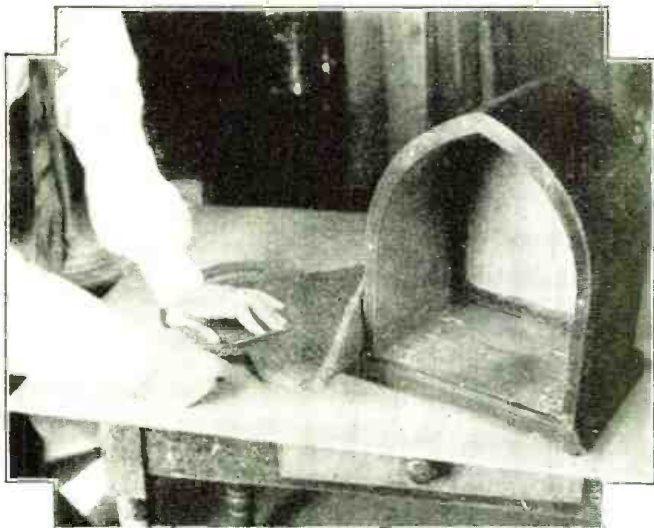

Service and repair men tell us they are often called in to work on a job where the dynamic speaker cabinet will have a resonant frequency set up by the speaker itself and which the ordinary methods of adjustment and placement will not cure. Under some conditions it is possible to place a layer of soft insulating material such as balsa wool on the sides and bottom of the speaker cabinet or the console itself if the speaker is mounted within the console. This insulating cover should be securely tacked to the woodwork in many places, so that it has a tendency to damp out the vibration of the cabinet walls and floor

Input Volume Control May Help Eliminate Distortion

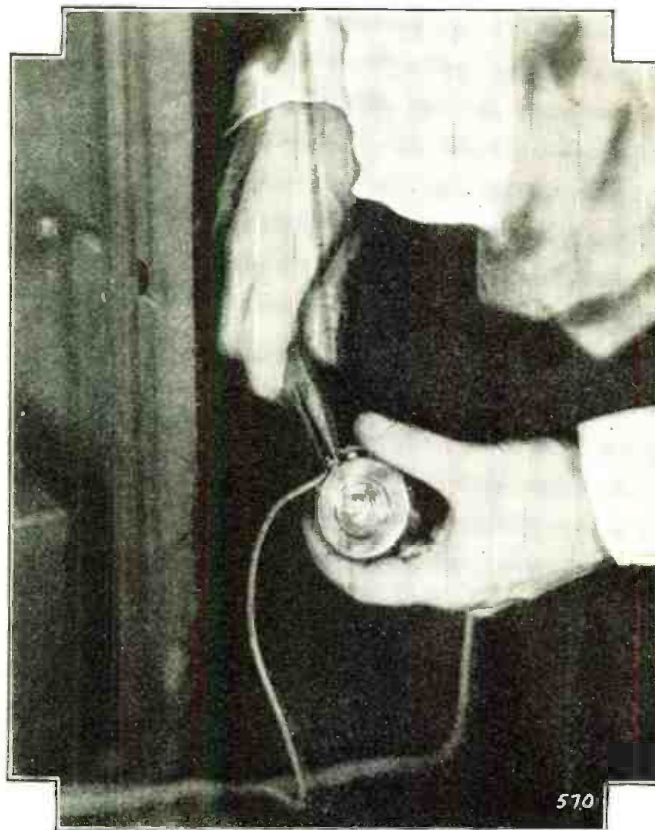

On many of the old style ardio sets the volume control placed in the radio frequency or audio frequency circuit often may give rise to distortion. This distortion may be eliminated by the use of a variable resistance placed from antenna to ground on the receiver. The variable resistance having an open position so that when full volume is desired the control is turned all the way and the circuit opened. Thus the old volume control is turned on to its maximum position or eliminated altogether and the new one used instead. There are also cases where no volume control at all was provided in old style sets and this method permits the set owner to increase or decrease the input from the antenna so that any degree of volume may be secured

Washers Used to Gauge Diameter of Holes to Be Reamed

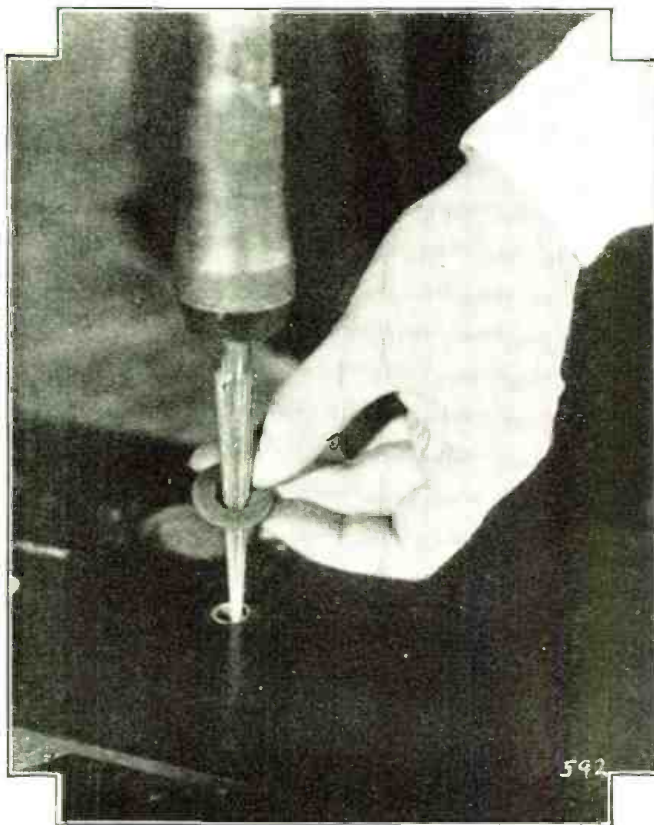

A comedian on the stage used to think it was very comical to ask his foil "How long is a piece of string?" but it isn't very funny when the builder has a number of holes to ream in a panel or subpanel and wants to get all of the holes the same diameter. Naturally there are no stops on a reamer, so the problem becomes rather difficult until the ingenious builder figures out the scheme shown in the above photograph. By using a set of different sized iron washers and placing one on the reamer, the builder may ream until the hole in the panel is the same diameter as the hole in the washer. Further progress will not be possible on account of the presence of the washer. By having several different sized washers it is possible to insure that all holes will be the same size as that particular washer

Cotter Pins Make Good Terminals on Cable Connections

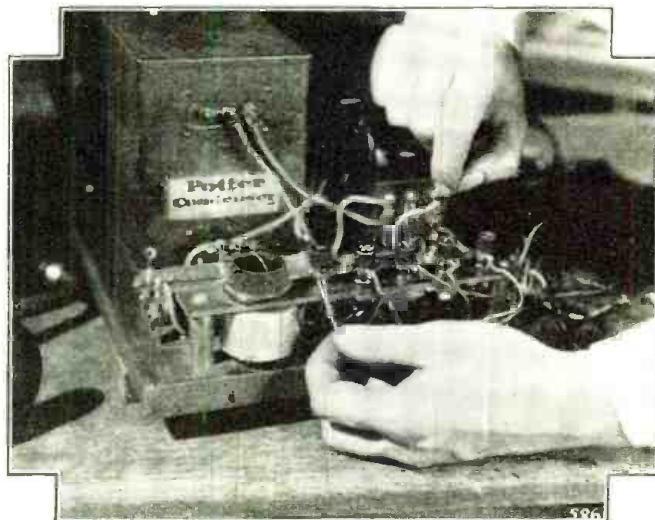

One usually associates cotter pins with automobiles or some other mechanical contrivance, but one enterprising set builder found he could use cotter pins soldered on to the end of his cable connections to eliminate the possibility of frayed wires. These cotter pins are pinched together at the end when being placed through the eye in a binding post and when they spread apart they produce some tension on the sides of the binding post eye. Further tension, of course, may be had by screwing up the binding post top. The wire is placed through the ring at the end of the cotter pin and a couple of turns are taken around the shank and the connection soldered

Measure Power Supply Under Load for True Reading



Voltage measurements under load and voltage measurements without load are two entirely different propositions, as the average service and repair man has found out in his experience with B eliminators separate from the radio set. Many times the customer will attempt to measure the voltages of the B eliminator when the set is not connected thereto and then when the set is hooked up he finds his voltages have dropped all down the line. The only time that a voltage measurement should be made of a B eliminator is when it is connected to its customary load, and the measurement should be made with a high resistance voltmeter to prevent the further dropping of voltages due to current consumption of the meter itself. If the B eliminator is of the type having variable voltage controls, the meter may be placed across the negative B and the desired intermediate voltage is read on the meter. This process may be carried out on all of the voltages required with fairly good assurance that nothing short of a short circuit in the receiver will drop off these voltage readings materially

Short Out Choke Winding to See If Filtering Properly

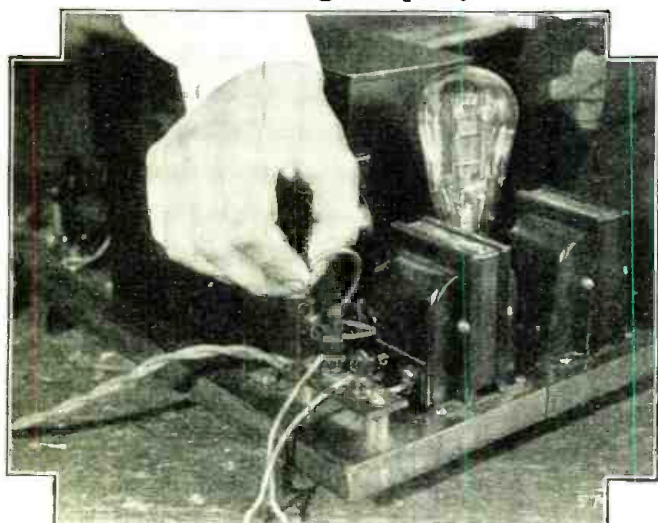

In the absence of an ohmmeter for reading the resistance of a filter choke in a power supply, the expedient illustrated above may be employed by the service man to determine whether or not a portion of the choke winding is performing properly. Almost all of the chokes are of the two-section type, so that by placing a jumper from the center tap of the choke and touching the wire on the outer end of the choke the hum in the set will increase when the first section of the filter is shorted out. Then the jumper may be touched across the second half of the choke and if the hum increases it indicates that both sections of the choke are performing properly. However, if there is no increase in the hum when one section is

shorted out, it may be assumed that particular section has become shorted internally or else is not functioning properly. This test will not determine anything as regards the continuity of winding, since if the choke were burnt open no voltages would be secured on the divider system and consequently no hum could be heard in the speaker

Probe with Bypass Condenser to Locate Hum Source

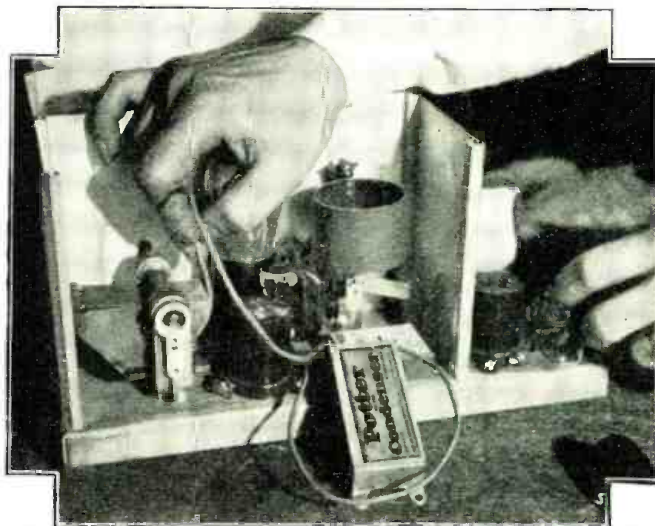

Insufficient filtering in the B eliminator, especially where the eliminator is not the one designed for the particular set you are using, may often give rise to a hum in the set, and even the addition of filter capacity across the terminals of the eliminator may not remove this hum. While the cure suggested above does not always work in every case, nevertheless set builders have had some success in eliminating this type of hum by means of taking a 1 mfd fixed condenser and putting it across different portions of the receiver circuit rather than across the eliminator divider system. In one case the hum was eliminated when the 1 mfd condenser was placed across the plus 22 line in the receiver and the A plus filament line. This happened when the addition of the extra 1 mfd in the power supply did not reduce the hum

Plug-In Coils May Be Built From Tube Bases

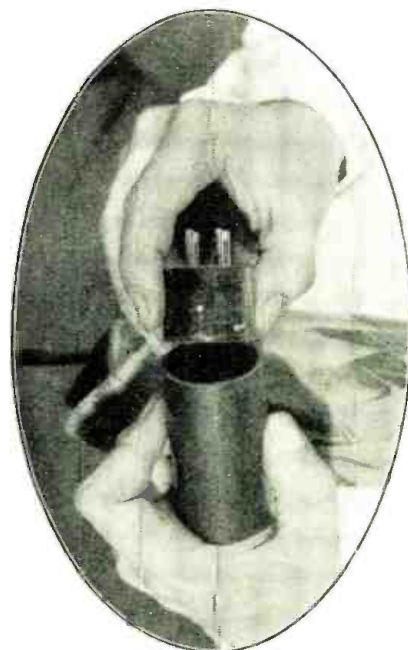

"Make it yourself enthusiasts" may find food for thought in the scheme illustrated in this picture, which represents the home-made construction of plug-in short wave or long wave coils. First take an old four-prong tube base, breaking off the glass and solder wires to the four prongs from the inside of the base. Then secure a piece of insulating tubing of a diameter that just permits its being shoved down over the old tube base. The bayonet pin on the tube base may either be cut off or retained as a guide for the depth the insulating tubing is to go over the tube base. If desired, small holes may be drilled through into the tube base and the structure locked by means of small brads. Then the coil may be wound for any desired wavelength and connections made through the inside of the tube on to the four prongs. This type of construction is only satisfactory where a simple primary and secondary winding is desired. If a regenerative winding is wished, some other method will have to be adopted for the connection, since there are no six-prong sockets

Four Screen Grid Stages Used in the National MB 29 Receiver

Radio Frequency Tuner Built as a Separate Unit to be Operated With Velvetone Amplifier

AT both the trade show and the two consumer shows during the year considerable interest was exhibited by fans and set builders in the National MB 29 a. c. screen grid tuner and power supply designed by the National Company of Malden, Mass.

The tuner in question is illustrated in the photograph shown in Fig. 1 while the photograph in Fig. 2 gives an idea as to the power supply. The schematic diagram of the tuner may be found in Fig. 3, while Fig. 4 discloses the electrical circuit of the audio amplifier and power supply.

Fig. 5 is a graphic wiring diagram for the benefit of home builders who wish an easy method for wiring the receiver.

Sensitivity and Selectivity

In the design of the kit illustrated on these pages the questions of selectivity and quality as well as distant reception have been carefully considered. Four tuned circuits have been used for the purpose of selectivity and the tuning very slightly staggered so as to modify the resonance curves, giving it a flatter top with steep sides.

According to the designers in using four stages of amplification with the a. c. screen grid tubes, the problem of careful shielding was encountered. It was found after a great deal of experimenting that if the coils were shielded, condensers and tubes could be left outside the shielding, providing the leads to the tubes and condensers were short. It was necessary to use a condenser gang which had little capacity between the stator plates. It was also necessary to confine the radio frequency current flowing in each particular stage. This

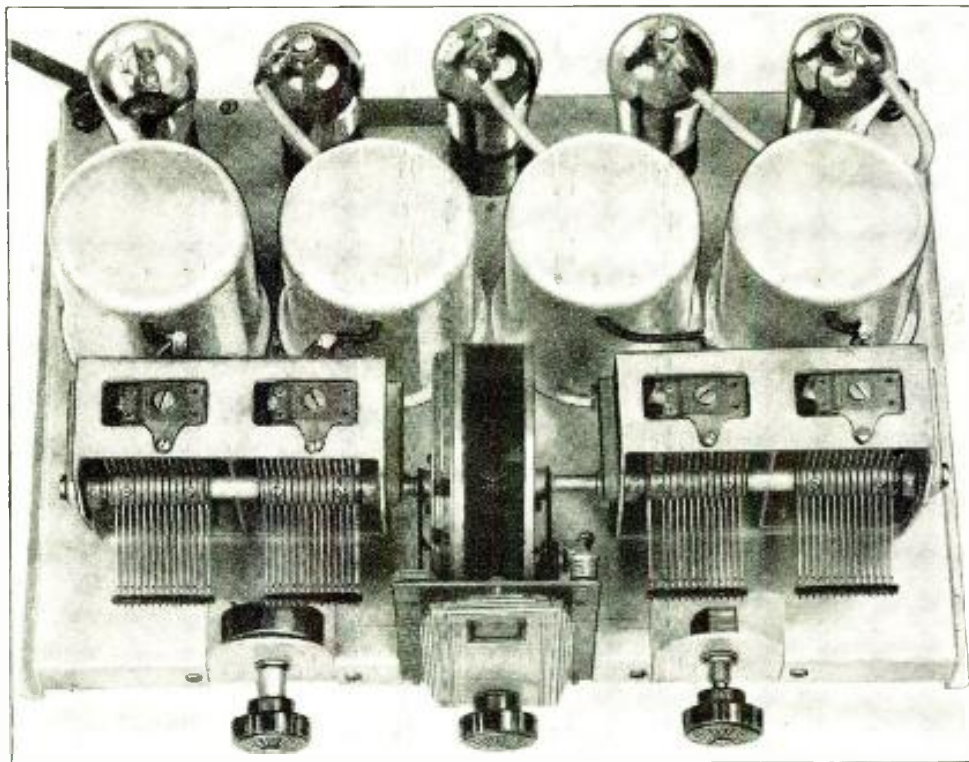

Fig. 1. The tuner portion of the receiver described herein is shown in this photograph

was done by placing the by-pass condenser and the r. f. choke in the plate circuit of each tube inside the shields which contain the coils. In keeping with the trend the kit was made a single control type. An untuned antenna system is used, consisting of a radio frequency choke coil connected in the circuit as shown in Fig. 3. This system has an added advantage besides the single control feature in that the ampli-

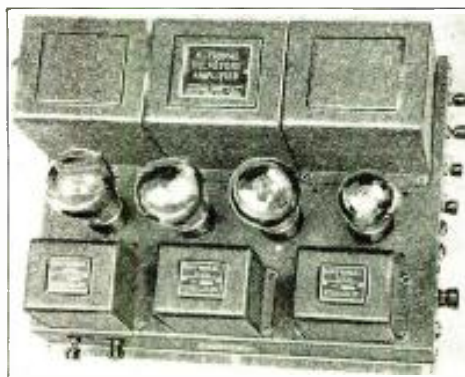

Fig. 2. The Velvetone amplifier and power supply is shown in the above photograph

fication of the radio frequency transformers falls off slightly on the long wave lengths while the choke coil antenna system is more efficient on the long wave lengths. Thus the combination gives a more even gain over the broadcast range than would otherwise be the case.

Assembly and Wiring Easy

Actual construction of the four-stage tuned radio frequency kit set is quite easy, as the National Company provides the base with the sockets in place, and the coils are obtainable in sets of four, all matched.

The leads are brought out from the coils to a small terminal strip mounted on the bottom of the shield. To facilitate wiring, the control grid lead is brought out in two places, one for connecting to the cap of the 22 μ , the other for connection to condenser stator plate.

Variable condensers used in this kit have small trimmer condensers built in each one, the purpose of these being to line up condensers and compensate for any capacity in the wiring. Once the condensers are lined up at minimum capacity, they are so matched that they will tune within one per cent over the broadcast band. This matching accurately allows for about the right amount of staggering in the combined stages, providing that the error is not accumulative. To take care of this, coils and condensers are both numbered so that the right coil is associated with the correct condenser.

In the construction of the set instead of using the shield as a ground, it is better actually to run a piece of bare wire to the various ground connections. This eliminates the possibility of the

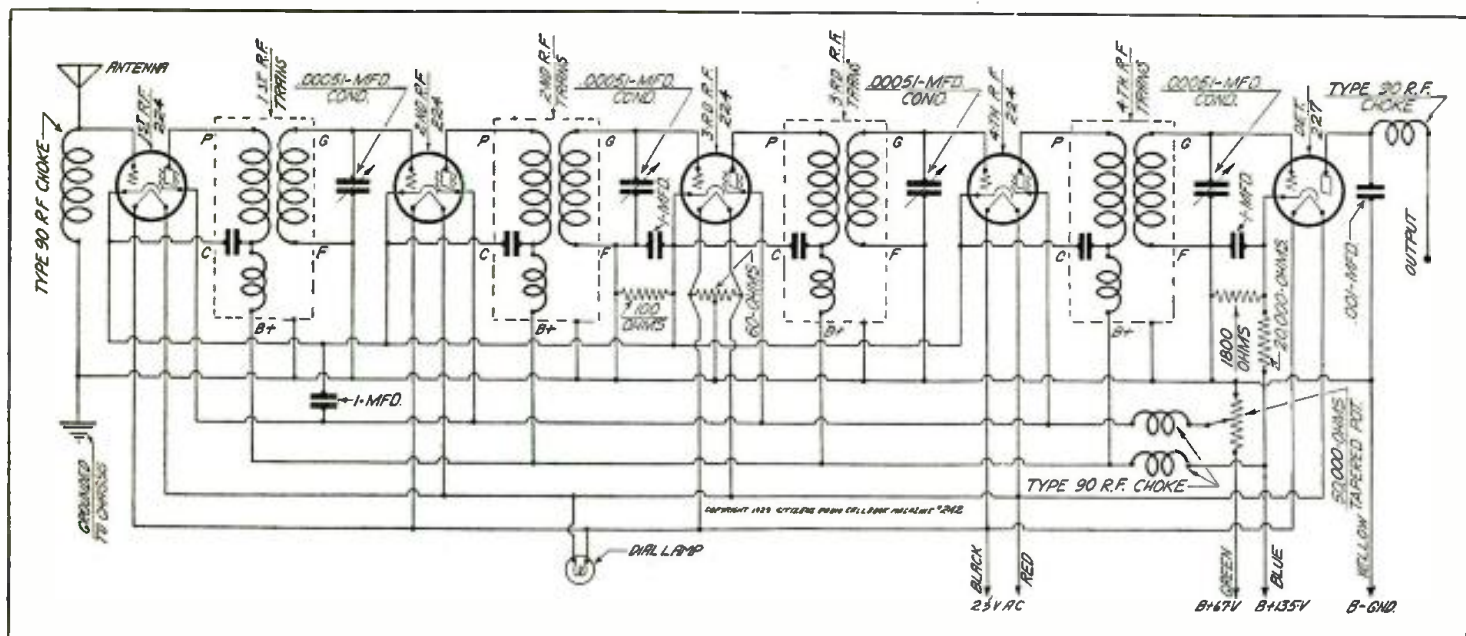

Fig. 3. Electrically the MB 29 tuner is represented in the schematic drawing above

high resistance joint which might make the receiver tune broadly. Again such joints have been the cause of sufficient intercoupling to bring about set oscillation. The ground wire should be connected to the chassis in several different places.

It will be observed that even though one end of the coil is connected to the shield, a wire is also brought out so that the connection may be made to the ground terminals of each condenser. The by-pass condensers in the shield compartments that hold the coils have a connection coming out through the shield marked "cathode." This allows the by-pass radio frequency current to return directly to the cathode of the tube without going through the resistance used to obtain the C bias. These leads should be run as directly as possible to cathode of the tube associated with the transformer. A radio frequency choke, external by-pass condensers and grid biasing resistors are located as shown in the graphic diagram, Fig. 5.

The volume control chosen is a potentiometer of 50,000 ohms connected between the minus B and the plus B 67 volts. The variable arm goes to the screen grid of the tubes through the radio frequency choke coils. In this manner the potential on the screen grid may be varied over a range from 0 to 67 volts. This type of volume control has the advantage of being completely out of any circuit where alternating current is flowing and consequently simply regulates the amount of amplification of the screen grid tubes.

Automatic Steady Bias

One of the features of the MB 29 is the employment of an automatic and steady C bias of proper voltage furnished to the grid of the power detector tube by means of special resistors, the

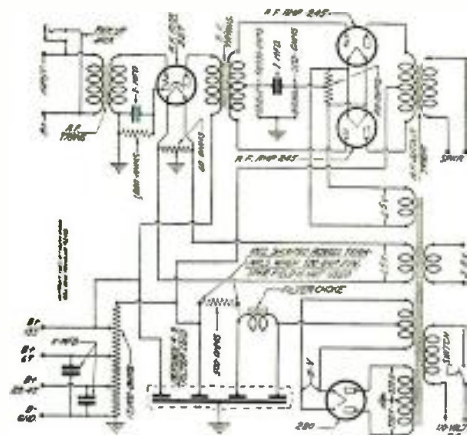

Fig. 4. This diagram shows the circuit of the Velvetone amplifier and power supply

cathode to ground resistor having a value of 1,800 ohms, while the cathode to plus 135 volts resistor has a value of 20,000 ohms. This form of bias re-

sistance connecting in the 227 power detection circuit enables the tubes to be operated at a more efficient value than in the conventional system of automatic grid biasing.

The MB 29 kit may be used with any radio amplifier system the set builder may prefer, although the Velvetone 245 push-pull amplifier was especially designed for this tuner. This amplifier has the correct voltage taps for the tuner and also has a separate winding for filament current for the five heater tubes.

Aside from the use of the new triple-section high-capacity Mershon filter condenser there are several circuit features worth mentioning. Perhaps the most noticeable, from the circuit diagram, is the use of separate filament and plate transformers; which makes possible a reduction of hum, compared

(Continued on page 127)

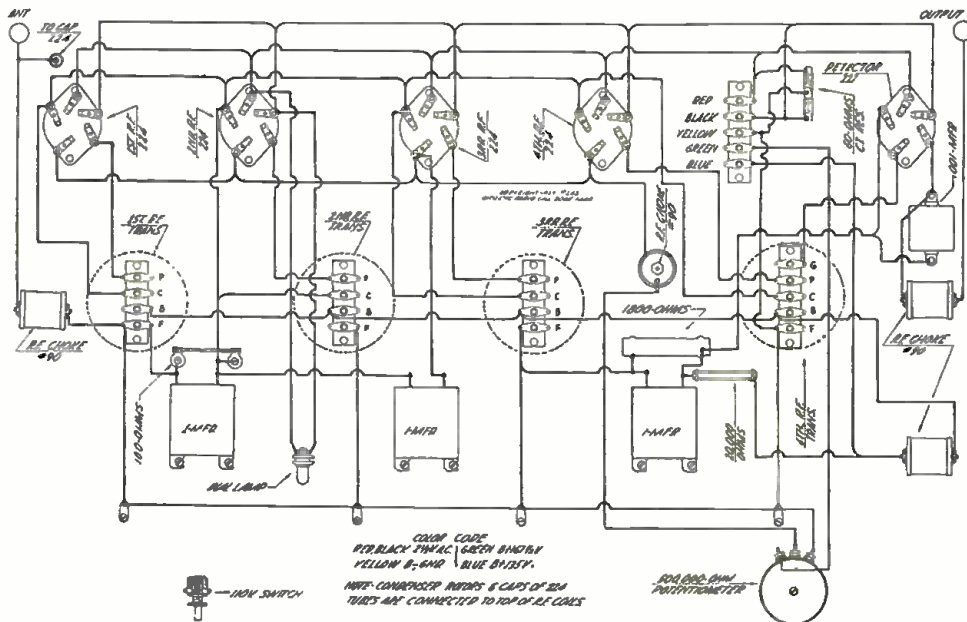

Fig. 5. For the home builder the graphic diagram shown here will serve as a wiring guide

"Hi-Q 30" Model Uses a Band Filter and 3 Tuned R. F. Stages

*Both Band Filter and R. F. Amplifier Tuned by Single Control;
Flat Top Tuning Secured*

DESIGNED by Hammarlund, the "Hi-Q 30" a. c. phono-radio receiver illustrated photographically and schematically on these pages, consists of a three stage tuned band filter or pre-selector, followed by a high gain three stage screen grid tuned radio frequency amplifier, a sensitive detector and a high quality intermediate audio amplifier and a balanced push-pull power amplifier. The nine tubes employed include a voltage regulator and a 280 rectifier, three 221 r. f. amplifiers, a 227 detector, a 227 first audio and two 245 power tubes.

Single Tuning Control

Both the band filter and the radio frequency amplifier circuits are tuned by a single illuminated knob control vernier dial with kilocycle graduations. Shielding has been carried out to an extent usually found only in an experimental laboratory receiver. The copper and aluminum shielding, the six tuned stages and the selective characteristics of band filter tuning provide an excellent degree of selectivity without side band cutting. The completely shielded screen grid amplifier provides most efficient amplification at all broadcast frequencies without unstable or regenerative distortion.



Fig. 1. This photograph shows the receiver mounted in an attractive console. The receiver unit is at the top and the speaker located below and in back of the grille

The 110 volt 60 cycle power supply and audio system is conventional and time tried. Automatic voltage regulation preserves tube efficiency and aids in maintaining a uniform voltage level.

Flat Top Tuning

A high quality band filter system pre-selects a desired signal before amplification. This principle provides flat top tuning, greatly increasing the selectivity without side band cutting and preserves the radio frequency signal's characteristics required for perfect tone. Background noises which so often interfere in the enjoyment of DX reception are reduced to a minimum. The advantages of filter tuning are especially valuable in congested localities where so many local stations exist and much interference producing electrical apparatus is found.

Little Wiring Needed

The complete set is built on a strong metal chassis with no visible wiring. The sub-panel wiring, unit construction, factory assembly, wiring and testing of filter and amplifier units make the construction a simple operation requiring only two or three hours of the set builder's time. The standard sized chassis 7 x 12 $\frac{3}{4}$ x 24 in. allows an unrestricted choice of cabinets. The walnut panel and control knob with the statuary bronze dial escutcheon and switch make the panel arrangement exceptionally pleasing and compact. The radio-phono

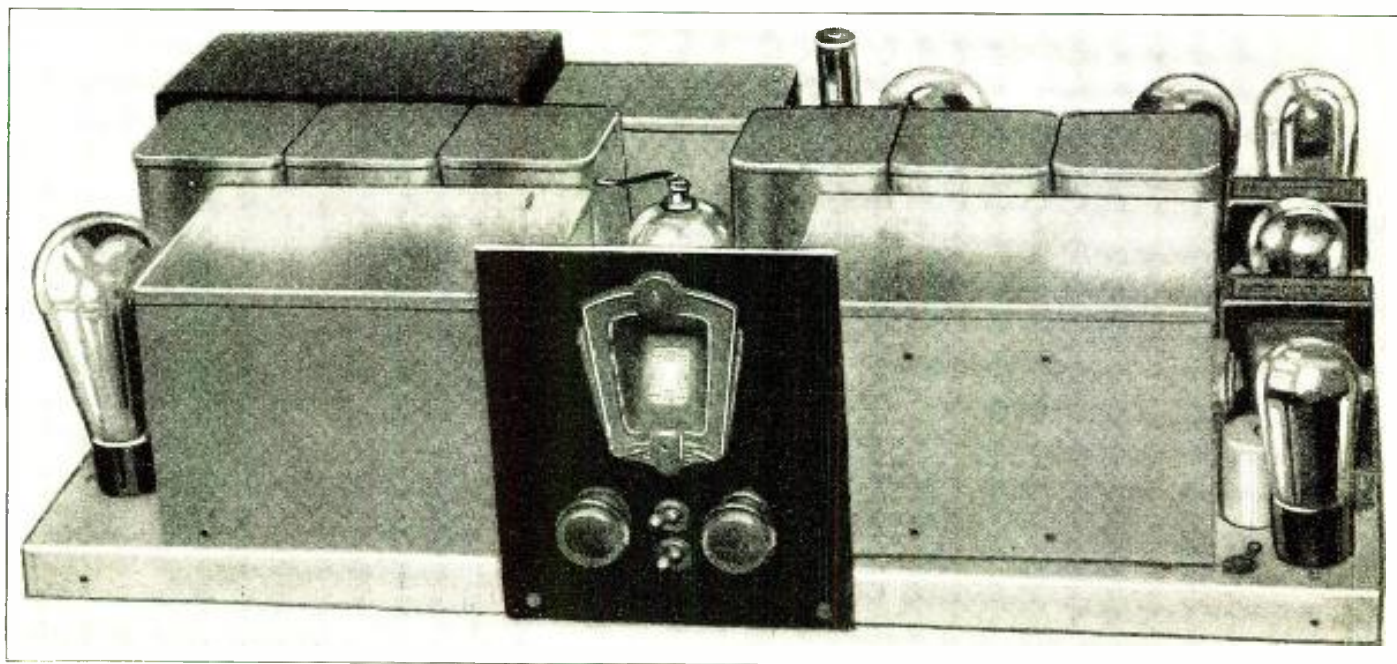

Fig. 2. The completed receiver is shown in this photograph. The band selector is at the left in the front while the three-gang condenser for the tuned r. f. stages is at the right, each being in a shielded compartment

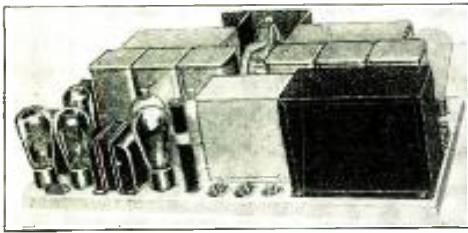

Fig. 3. This is a photograph of the rear of the model described in the accompanying article

switch is mounted on the front panel for convenience of operation.

The "Hi-Q" operates on either an inside or outside antenna. A copper screen tacked on the rear of the cabinet serves for local reception.

Instructions covering the wiring up of the units employed in the receiver are listed below.

Wiring Instructions

The wiring may now be done per Fig. 5 (supplied with kit). It is suggested that a colored pencil be used to mark out each wire on the diagram as that wire is connected. Caution must be exercised in the matter of making correct connections but if the diagram is followed exactly no difficulties will be encountered.

Where wires are joined together, or where other bare surfaces occur, a liberal use of insulating tape is recommended. Ordinary adhesive tape will do if electricians' tape is not available.

The three Electrad "black" resistors are 5000 ohms each, the "green" resistor is 800 ohms, the two "yellow"

resistors are 400 ohms, and the "red" resistor is 2000 ohms. The two Durham midget resistors are 25,000 ohms each and are supplied as part of the foundation unit. The Yaxley center tapped 10 ohm resistor is mounted in place by soldering its center terminal to a lug secured under the nut in the position shown in Fig. 5. Soldering lugs should be used on the terminals of the duplex receptacle and at other points as indicated.

The .001 mfd bypass condenser is supported by its terminals as shown in Figs. 4 and 5. One terminal is soldered to the double lug on the socket mounting screw and the other terminal is soldered to the nearest terminal of the shielded choke. The terminals of the condenser should be bent to make the above connections.

After wiring is completed each connection should be carefully checked to assure proper operation of the receiver. A wrong connection may easily make the difference between perfect results and poor results—or may even cause considerable damage to parts.

A series of voltage tests may be made later, using a high resistance d. c. voltmeter of the double scale type and a triple scale a. c. voltmeter.

The use of an Amperite voltage regulator tube is strongly recommended but where the line voltage is so uniform as to make its use unnecessary, the two terminals of the Amperite socket may be connected together and the connection to the terminal marked 30-V in Fig. 5 must then be moved to the terminal marked 110-V.

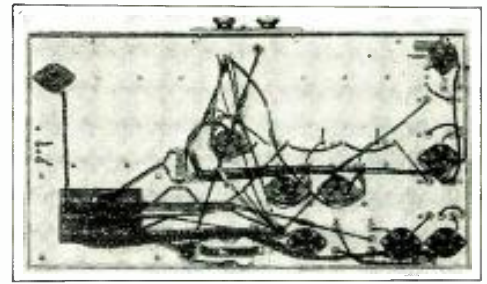

Fig. 4. Since all units are wired, all that the custom builder needs to do is to connect the wired units together, such connections being made at the bottom of the sub-panel. It can be readily seen that very little wiring is required to put the receiver in operation

Balancing Receiver

Now remove the covers of the variable condenser shields and turn the rotor plates of both condensers so that they are fully meshed. Then slide one of the coupling sections over on the short draft in such position that it still engages about 1/16 in. of the long shaft. The set screw in this half of the coupling should now be tightened securely. The other half of the coupling should now be placed so as to engage the first half leaving about 1/32 in. between the end of the tongue and the bottom of the groove. The set screw in this half may now be tightened.

Now turn the dial knob to the right until the stop is reached. The set screws in the drum drive should now be tightened.

If the dial light has not yet been placed in its socket now is the time to (Continued on page 132)

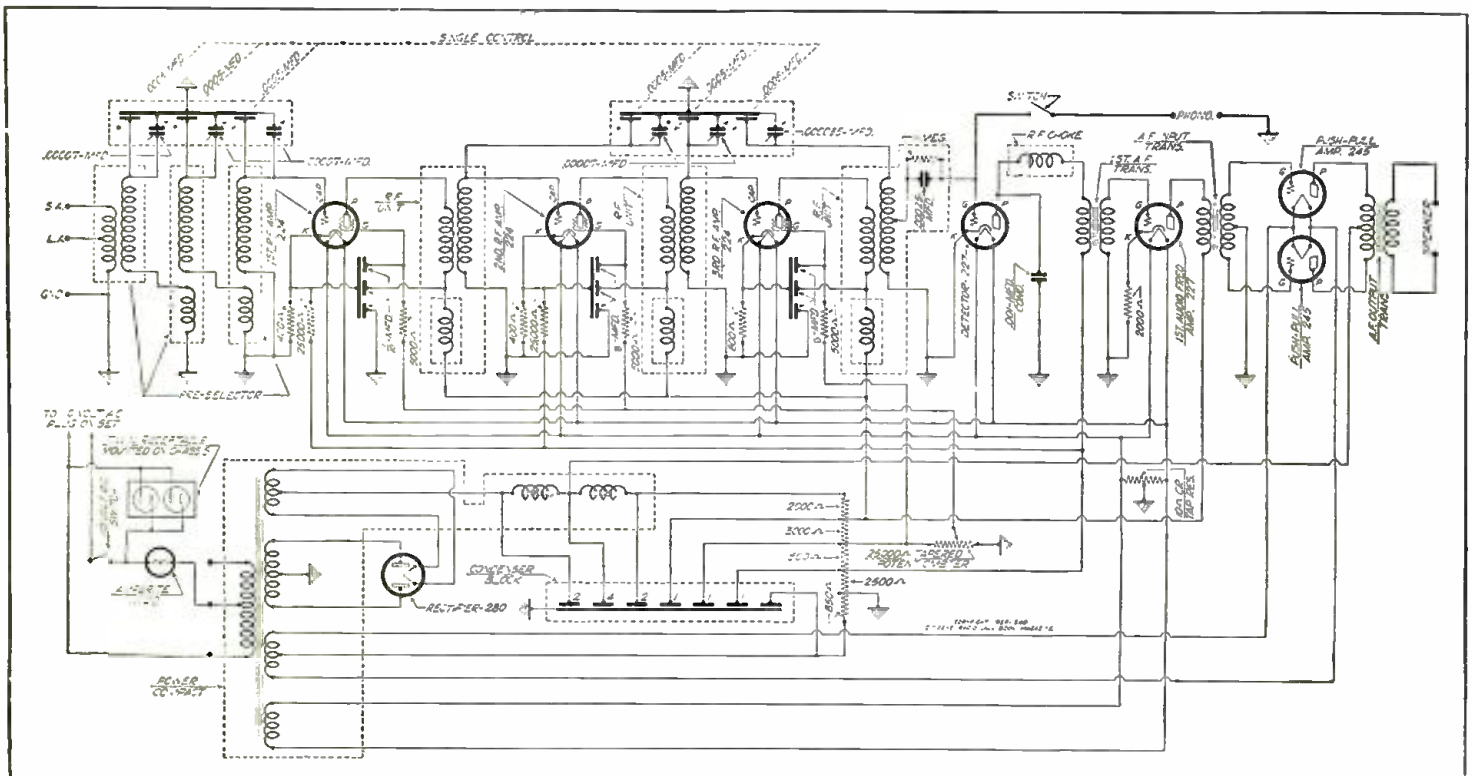

Fig. 5. The schematic diagram of the receiver and its power supply is given in the drawing shown here. The band filter is shown at the top left, while the succeeding tuning section is the one for the radio frequency amplifier

S-M 712 Band Selector Tuner Now Goes in Class With Supers

*A. C. Model Supersedes the 710 With Better Gain and Selectivity:
is Easier to Operate*

THE improvements in amplification at broadcast frequency during the past two years have steadily reduced the margin in performance between superheterodyne and tuned radio frequency receivers until today with the introduction of the Silver-Marshall 712 band selector tuner may be found a tuned radio frequency receiver with superheterodyne performance. The high gain and selectivity associated with superheterodynes are obtained by the use of 22A tubes with specially designed transformers and through the use of five tuned circuits, including a "siamese" or band selector circuit. This receiver has an average sensitivity of "less" than a microvolt per meter, which means that its distance range is limited only by the noise or stray level.

Sargent Rayment Superseded

The Sargent Rayment 710 receiver set a performance record last year which placed it definitely in the superheterodyne class. Verified reception of Japanese, Australian and European stations were so common in some locations as to be almost regular. The S-M 712 tuner and 677 amplifier combination which supersedes the 710 has even greater gain, better selectivity, and is very much simpler to operate and maintain since it is an all a. c. unit and has no trimmers or verniers of any kind.

The superheterodyne circuit was invented at a time when very little amplification could be secured at high frequency in a receiver. Improvements in r. f. amplification at broadcast frequencies have been so great during the last three years that twice the amplification is now secured at broadcast frequencies that was formerly secured at intermediate frequencies. Developments in band

selector circuits with greatly improved selectivity have made it possible to use this added amplification with a minimum of interference on distant stations.

Radio frequency tuners have the advantage over the superheterodyne of requiring fewer tubes (where the transformers are properly designed and there is high gain in each stage) because no first detector and oscillator are necessary and the gain is more uniformly high if the receiver is the single dial type because of the difficulty of maintaining alignment between the oscillator and radio frequency circuits. A certain amount of radio frequency amplification is a necessity in the superheterodyne if

coupler coil of this circuit is detuned to a negligible extent by even a moderately long antenna, although an antenna three or four feet long will normally provide all of the input required for the tuner.

In a band selector circuit, for maximum energy transfer, the product of the resistance of the two coils should equal 6.28 times the frequency in cycles times the mutual inductance. The coils used in this receiver have been so designed that the resistance varies almost directly with the frequency so that optimum energy transfer is secured over the whole band.

The band selector circuit is followed by three straight tuned transformer coupled stages. These have a minimum to maximum gain ratio of one and a half which is very much better than the conventional interstage transformer.

Precautions Taken

Because of the high gain, unusual isolation precautions have been taken. Both the plate and screen grid circuits of each stage are isolated through high impedance chokes. The control grid circuits have their return to one common ground point in each circuit and

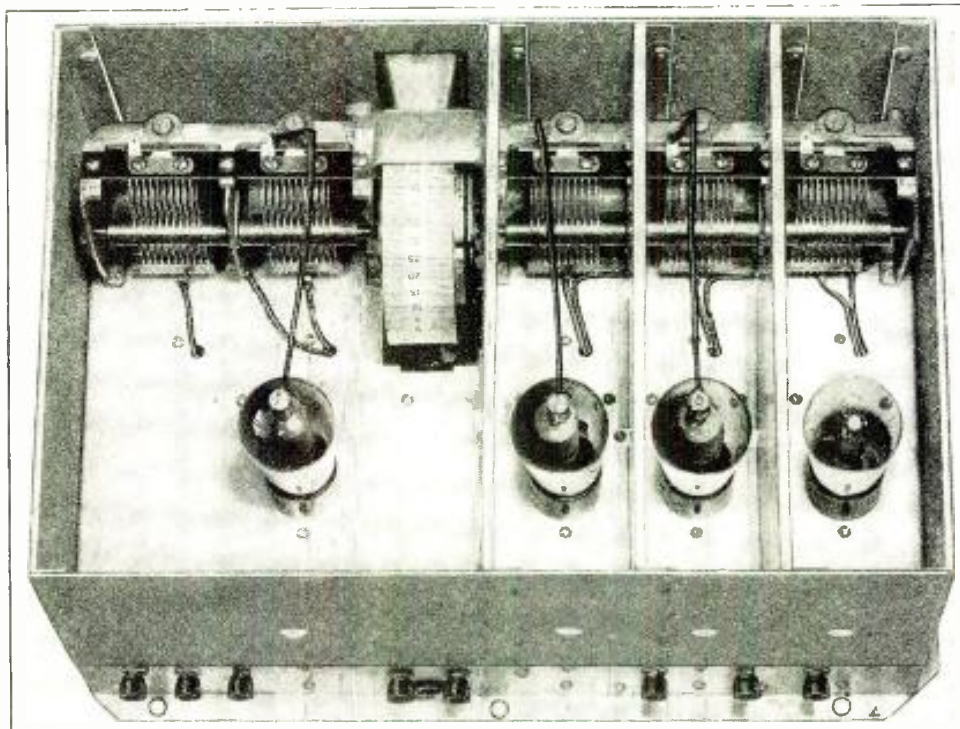

Fig. 1. The tuner of the 712 is shown in this photograph

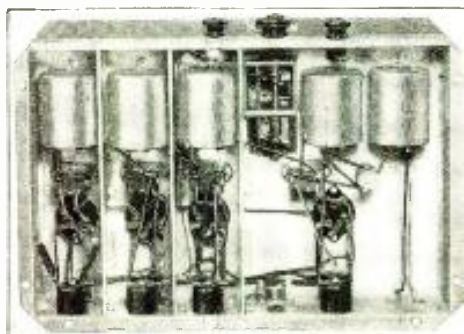

Fig. 2. This is a bottom view of the parts and wiring in the 712

objectionable harmonics and cross-talk are to be eliminated and in practice it is found that a high gain superheterodyne should have at least two stages of radio frequency amplification ahead of the first detector. From this, it is evident a very much simpler and more efficient design can be involved in a high performance radio frequency tuner.

Short Aerial Necessary

In the S-M 712 tuner the antenna is coupled directly to the "siamese" or band pass circuit. The antenna

Pre-Selection Tuning Used in Nelson Model N-30 A. C. Receiver

Inductance and Capacity Network Tunes Signal; Is Then Amplified Through Aperiodic Amplifier

MARKING the entrance of a pre-selector circuit into fan channels comes the announcement of the Nelson model N-30, pictures and diagrams of which are shown on these pages.

As will be seen from an examination of the schematic diagram in Fig. 3, the circuit employed in the N-30 is a pre-selector type built under the Technidyne patents. The pre-selection portion of the circuit is shown at the top left of the schematic drawing, while the amplifier is shown in the lower part of the drawing. Signal enters from the antenna where a network of fixed inductances and variable capacities accomplishes the tuning and filtering. The tuned signal is then led into the grid circuit of the first stage of the Technidyne amplifier and is then amplified through succeeding aperiodic stages until it reaches the detector. The five aperiodic r. f. stages employ the 227 type of tube while the detector also uses this same kind of tube except that detection is accomplished by what is commonly known as power detection. The plate voltage of the detector is approximately 180 volts and the bias on the grid of the detector is approximately 20 volts negative.

Audio in Power Supply

The 245 tube arranged in push-pull arc not located in the receiver proper but are found in the power supply. This supply also has the 280 rectifier furnishing B and C voltages for the receiver.

The Nelson N-30 is designed to use a dynamic speaker having a 6,000 ohm field and for this purpose the Jensen dynamic has been chosen. The output transformer of the receiver is designed to go into the moving coil of the dynamic and will not work satisfactorily through the input transformer ordinarily used on the average speaker.

In order to prevent the possibility of condenser burn-ups, the Mershon filter condenser is used in the rectifier circuit. This is of the electrolytic type and is impervious to voltage surges. The capacity of this condenser is 8 mfd per section, there being three sections, making a total of 24 mfd. Simply analyzed the Mershon condenser consists of rolled aluminum electrodes in a copper case, these electrodes being cov-



Fig. 1. This photograph shows an open view of the console with the Nelson N-30 installed

ered by an oxide film. A coated aluminum sheet is the anode. The oxide film is the dielectric of the condenser and is formed electrolytically in the process of manufacture. A liquid called the electrolyte serves as the cathode and makes contact with the copper containing can to which external connection is made



Fig. 2. The chassis and speaker may be seen at the rear of the console

by clamping to the subpanel of the radio set. Although the Mershon will break down under an applied voltage of over 415, no damage will result unless the amount of leakage current and consequent heating of electrodes and solution causes it to boil. Instantaneous surges of voltage do not damage the film. After the condenser has been unused for several weeks it may take as long as five minutes after the radio set is turned on for the condenser to reform properly. However, after having once been reformed the operation of the condenser is instantaneous thereafter. The normal leakage current of the condenser is $\frac{1}{4}$ milliamperes per microfarad.

The antenna and ground posts are plainly marked. The field wires of the speaker are attached to the binding post marked "speaker field" on the back of the set. The moving coil leads are inserted in the moulded phone tip jack marked "speaker." The leads from the phonograph pick-up are inserted in the moulded phone tip jack marked "phonograph."

Three Control Knobs

Looking at the set from the front there are three control knobs. The control on the left furnishes the volume, the volume being at a maximum when this knob is rotated completely in a clockwise direction. The control in the center is the tuning knob, while the control knob at the right is the "off" and "on" switch. The set is on when this knob is turned in a clockwise direction and off when it is turned in a counter-clockwise direction.

In the back of the set at the left will be found a switch marked "radio-phonograph." For radio reception this switch is turned so the handle points to radio. When the phonograph pick-up is used, this switch is turned so the handle points to phono. When using the set for phonograph reproduction, the volume control should be turned completely off, otherwise both radio music and phonograph music can be heard at the same time. Practically any make of phonograph pick-up may be used with an N-30 with satisfactory results. The phonograph pick-up may be connected to the set and left in position as it is completely short-circuited by the phonograph switch when the switch is turned to "radio."

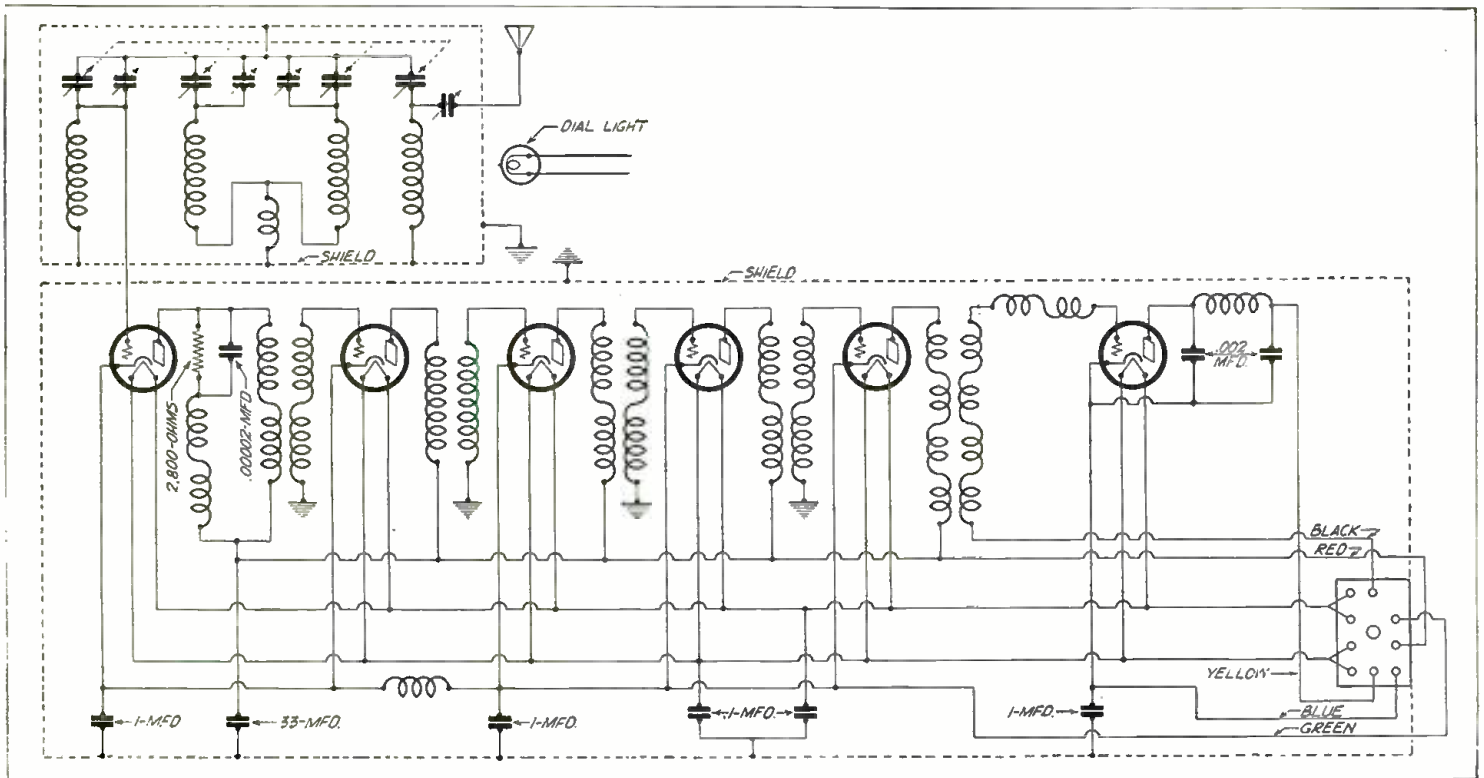

Fig. 3. Schematically the circuit used in the Nelson N-30 is shown in this drawing

It will be noted that the dial is calibrated in kilocycles as well as having the usual degree markings. This calibration, of course, will not be absolutely accurate, as the accuracy depends to a great extent upon the adjustment of the trimmer condensers and since it is necessary that these condensers be adjusted outside of the factory, it will be noted the kilocycle readings may be slightly off. However, the calibration will be close enough to permit locating any broadcast station if its frequency is known.

Special tubes are employed in this receiver and are made for Nelson by Arcturus. In the Technidyne type of amplifier it is imperative that special tubes be used if the maximum selectivity and sensitivity of the set are to be secured. In an emergency the regular 227 tube may be used, but only until a replacement of the proper kind can be found.

Adjusting the Condensers

Before the chassis is installed in the cabinet, the tuning condenser should be adjusted using the tubes with which it is intended to operate the set and the antenna which will be used with the set. The trimmer condensers are adjusted with the insulating screwdriver which is supplied to jobbers and dealers. The following is the procedure for the correct adjustment of the condensers: ground and antenna wires are connected to their respective binding posts on the chassis. The volume is turned completely on. A station should be tuned in at approximately 20 to 25 on the

dial. Adjust the trimmer on the left-hand condenser, as the set is looked at from the front, until maximum volume is obtained. Then adjust the second and third trimmer condensers until maximum volume is obtained. If more sensitivity is desired the main tuning dial should be shifted back and forth slowly until the signal intensity is the greatest and the trimmers can again be

more finely adjusted for the final setting. Number four trimmer should not be varied, as to do so may make it impossible to cover the entire broadcast range. After the set has once been adjusted with a good set of tubes, the only trimmer which will ever need further adjustment will be the antenna trimmer, and this only upon changing the antenna used.

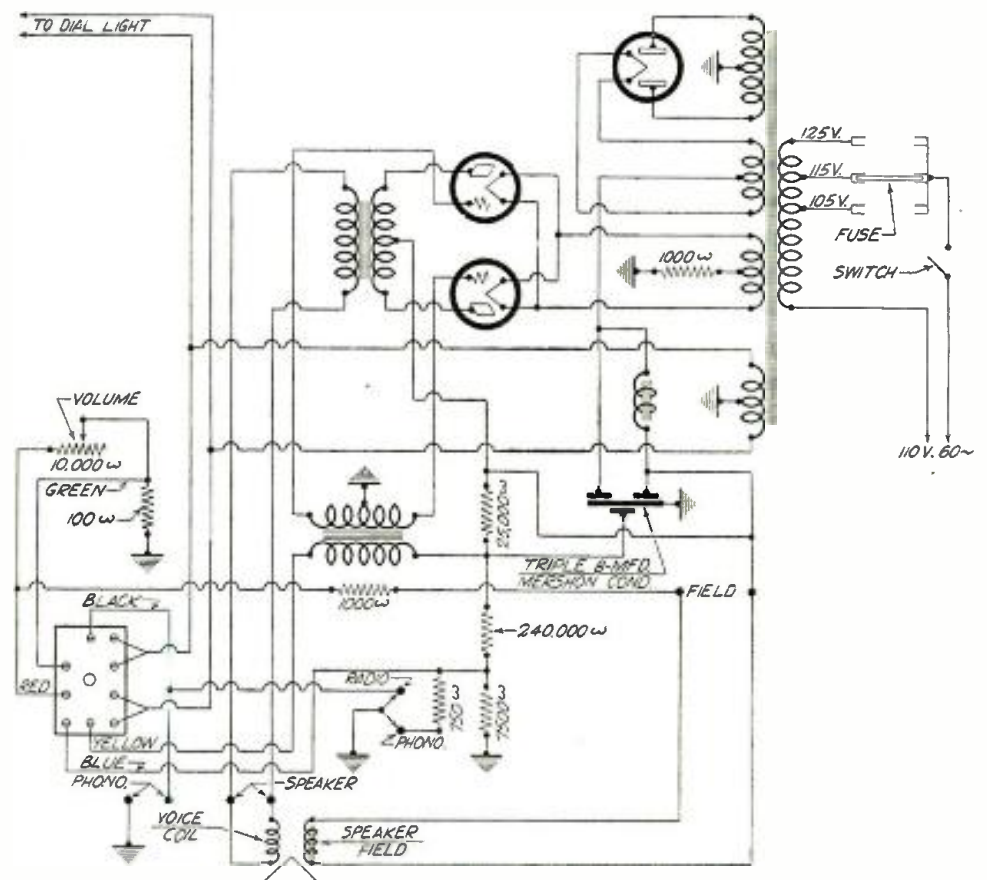

Fig. 4. This diagram is the schematic of the power supply unit for the receiver

Aero Announces "Overseas Four" All Electric Short Wave Set

Novel Tuning Arrangement Permits Following Short Wave Broadcasts; Uses Screen Grid R. F. Stage

OBSERVERS of radio conditions have noted with interest that as progress is made in transmission and reception on the higher frequencies, the listening public shows a greater desire to experience the thrill of transcontinental and transoceanic reception of broadcast programs. No doubt the tendency is towards the use of a complete short wave receiver electrically operated which may be used either alongside a stand-

ard broadcast set or may be operated in another room for reception of short wave programs. While it is true that the adapter idea for converting a standard broadcast receiver into a temporary short wave receiver has many adherents, nevertheless it is readily discernible that there is a growing sentiment for the completely self-contained electrically operated short wave receiver.

Overseas Four Announced

This trend has been observed by Aero Products, Inc., whose recently announced Overseas Four all electric short wave receiver is described in this publication for the first time. An examination of the photographs and the schematic in this article will give the reader a clear idea of the receiver and the possibilities of its use for entertainment purposes.

The photograph shown in Fig. 1 is of the receiver with the top cover removed. At the extreme left in the rear is the 280 full wave rectifier tube which furnishes plate and C voltages for the entire set. The filter choke, its bypass capacitors and the power transformer are contained in the square units at the rear of the receiver sub-panel. The screen grid tube is shown at the extreme left inside of the tube shield. Next to the right is the plug-in short

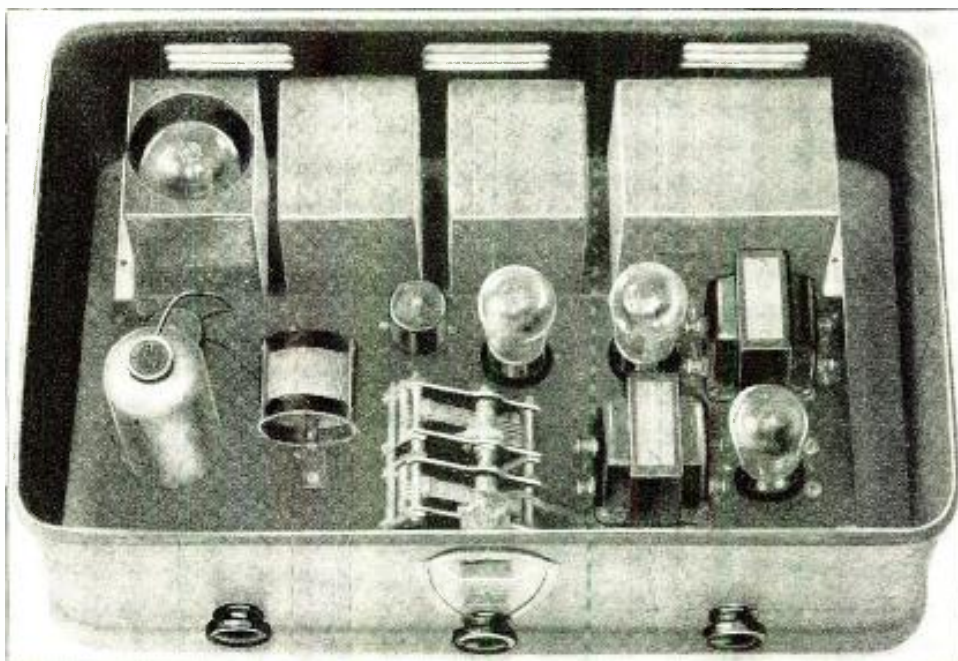

Fig. 1. Here we see the Overseas Four with tubes installed and ready for operation

wave and long wave inductance followed by the tandem tuning condenser, one-half of which is in the circuit for tuning over a portion of the wavelength range and the two sections, or the total capacity, when tuning over the greatest range, which represents the standard broadcast portion of the wavelength of the scale.

Two Controls

In the photograph under Fig. 2 may be seen the front panel of the receiver with its two controls. The one at the left is for regeneration and volume. The control at the center governs the wavelength of the receiver through



Fig. 2. There are only two controls on the panel of the receiver as shown in this photograph. The one at the left is for volume and regeneration while the center control is that of the tandem tuning condenser. The on-off switch is located at the right. The cabinet is of metal and serves as a shield for the receiver

the variable condenser. An on-off switch which starts and stops the power supply is located at the right.

There are five tubes required for the operation of the receiver. One is the type 224 which is employed as a radio frequency amplifier in the first stage. The detector utilizes a 227, which type of tube is also used in the first audio stage. The power stage makes use of a type 112-A whose output is fed into the speaker. The fifth tube is the

280 rectifier which furnishes B and C voltages for the receiver equipment.

Referring to the schematic diagram shown in Fig. 3, it will be seen that energy enters the antenna into a type 65 choke coil located between the grid and ground of the 224 r. f. amplifier. This choke coil is of the aperiodic type and does not require tuning. Bias for the grid of the 224 is secured through the drop across a 200 ohm fixed resistance between the cathode and ground. This resistor is bypassed by a .01 mfd fixed condenser. In the screen grid circuit another choke coil is employed, this being the type 60 and it is bypassed direct to ground from the terminal by a .003 mfd condenser. The tube shield which is used around the 224 is made common with ground. In the plate circuit of the screen grid 224 a second type 60 choke coil is employed, the lower extremity going to 135 volts for the plate of that tube. The screen grid voltage applied to the lower portion of the choke coil in the screen grid lead is 67 volts. The coupling arrangement between the plate of the 224 and the grid inductance of the 227 detector is a .0001 mfd fixed condenser. The grid inductance socket is one having three terminals for the secondary and two for the plate coil. One section of the .00014 mfd tuning condenser is across ground

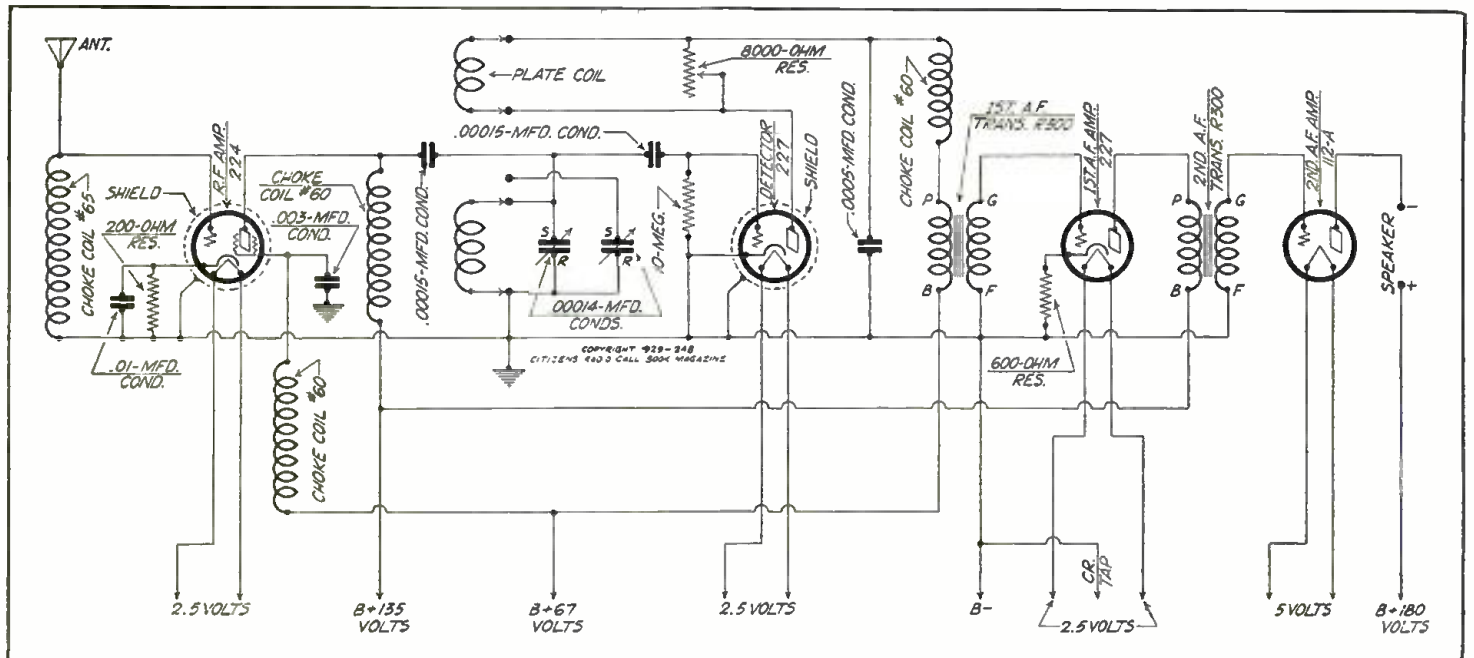

Fig. 3. The schematic diagram of the Aero Overseas Four is printed above. An examination of this will give the reader an idea of the functions of the receiver

and one terminal of the coil socket, while the other section of the variable capacity having .00014 mfd is across ground and the third terminal of the coil socket. By this method the shorter wavelength coils requiring a small capacity for tuning purposes utilize two terminals of the coil socket. When it is desired to increase the capacity range for covering a broader scope on the higher wavelengths coil a strap connection between two terminals of the coil places these two variable condensers in parallel with a resultant broader tuning range. The grid coupling condenser is a .00015 mfd and the leak is a 10 megohm from grid to cathode of the 227. This cathode is also common with ground. A tube shield is not used around the 227 detector to reduce the possibility of linkage between the coil and the tube, because it was not found necessary with latest design coils.

Regeneration Control

Regeneration in this circuit is by means of an 8000 ohm variable resistor placed across the extremities of the plate coil. Both the plate and the grid inductance are located on one plug-in coil so that when switched from one hand to another both circuits are changed simultaneously by merely plugging in a different sized coil. The 8000 ohm variable condenser is used both as a volume and regeneration control. When it is desired to receive telegraph signals the control is thrown all the way over until the detector tube oscillates. When it is used for broadcast reception the control is advanced until the tube is regenerative and in that position maximum volume is secured in the speaker. If less volume is desired the control is retarded.

The regenerative circuit is bypassed

with a .0005 mfd mixed condenser and a third type 60 choke coil is used to prevent r. f. current passing through the winding of the first audio primary. The detector tube plate uses 67 volts, which is the same value as is applied to the screen grid of the preceding tube. On account of grid leak and condenser rectification in the detector tube, the cathode is common with ground. As previously described, the bias for the first audio stage is secured by a 600 ohm resistor placed between cathode and ground on the 227. The filament winding for the first audio goes to a 2.5 volt secondary on the power transformer, whose center tap is common with B negative. The detector filament circuit goes to another 2.5 volt winding and the same is true of the filament circuit of the 224 screen grid.

Bias for the 112-A power tube is provided within the power pack. Filament circuit of this tube is from the 5 volt secondary.

Calibration of Coils

According to the calibration chart of the coils used in this receiver, the first coil tunes from approximately 48 meters to 98 meters; the second coil covers the range from 30 to 56 meters, while the third coil covers the range from 16 to 32 meters. These are the coils supplied with the receiver.

For broadcast operation there are two coils, the smaller one, RC4, tuning from about 175 to 275 meters and the larger one, RC72, tuning from 250 to 550 meters.

Some of the instructions covering the operation of the receiver may be of interest to our readers. The receiver should be set up in a room where it will not be knocked or jarred and conveniently located for antenna and ground

connections. It should be kept away from metal objects, such as stoves and radiators. It is also important that it be protected from moisture or dampness.

A good antenna well insulated is quite necessary. For good results on short waves a length of from 60 to 100 feet including the lead-in is recommended. The antenna may be anywhere from 16 to 50 feet high.

In connecting the receiver up, remove the coils from the case. Remove the tube shield from the screen grid tube socket. Insert the tubes, the 224 at the left, placing the shield over the 224 tube and connecting the shield grid tube cap to the screen grid. A 227 type goes in the last stage to the right, then another 227 to the right of the first one, while the last socket is for a 112-A. The first 227 tube also has a tube shield placed over it. Recheck everything carefully being sure the antenna is properly connected to the antenna binding post. A ground may be connected directly to the case of the receiver. After the speaker terminals have been connected, insert the plug into the 110 volt 60 cycle power supply. If there is an unnecessary hum try reversing the plug in the power supply of the 110 volt source. It usually takes a minute for the tubes to heat up to the proper temperature for best results.

Easy to Operate

This receiver is easy to operate once it is understood that it is not like the average broadcast set. It tunes much more sharply but after once learning its operation and locating the various short wave stations no difficulty will be encountered in finding them again. By means of the calibration chart of the Overseas Four, it is possible to select

(Continued on page 132)

Scott Designs Short Wave Converter for His A. C.—D. C. Supers

Unit Plugged Into First Detector Makes Short Wave Super Out of His Screen Grid Models

BRINGING the Scott line of screen grid superheterodynes, both d. c. and a. c., up to a fuller measure of service, it has just been announced that Scott Transformer Co. is marketing a short wave converter by means of which either the Scott screen grid a. c. 10 or the Scott shield grid 9 broadcast receivers may be converted into short wave superheterodynes, with eight tubes in the case of the shield grid 9 or nine tubes in the case of the a. c. 10. There are two types of the converter, one of the a. c. type for the a. c. 10 super and the d. c. type for the shield grid 9.

Using Tank Condenser

By referring to the schematic wiring diagram shown in Fig. 3, one will observe there are several departures from conventional short wave converter practice. One feature is the fact that a tank condenser .000135 mfd is tuned by means of the small knob on the right-hand side of the converter shown in Fig. 1 and marked "minimum—1—2—3—maximum." The second condenser is a .00007 mfd and is on the dial of the converter. This is the condenser with which the actual tuning is performed. The capacities of these two condensers added together are equal to the capacity of a single condenser that



Fig. 1. This is the first model of the Scott short wave converter described for the first time in the accompanying article

would normally be used to cover the band in a regular short wave receiver or converter. By this method it is clear to see that he has a tuning dial exactly four times as large in effect as the tuning dial on the regular short wave converter or short wave receiver. With the system of tuning condensers employed in the Scott design, it is possible to cover the short wave spectrum with three coils. By the arrangement of a

tank condenser having five tuning positions, it is possible to tune in a broadcast signal on short waves with greater facility than would ordinarily be encountered since the tuning is done with the very small capacity.

In Shielded Can

All of the condensers and the detector tube are completely enclosed and shielded in a very solid burnished copper can. This assists materially in stabilizing the action of the converter and eliminates body capacity without effecting the efficiency of the converter.

Chart Furnished

A calibration chart is furnished with the coils and it will be noted that there are three tuning curves, each of these curves plugging into four sections. For example: Supposing one wished to tune in a station on 28 meters. Coil No. 2 would be plugged in which covers a range between 23 and 40 meters. By setting the tank condenser at "minimum" and setting the main tuning dial somewhere between 50 and 70 degrees, 28 meters should be found. If it is desired to tune in a station on 64 meters, coil No. 3 may be plugged in which covers from 36 to 76 meters. The tank condenser should be set at "1" and be-

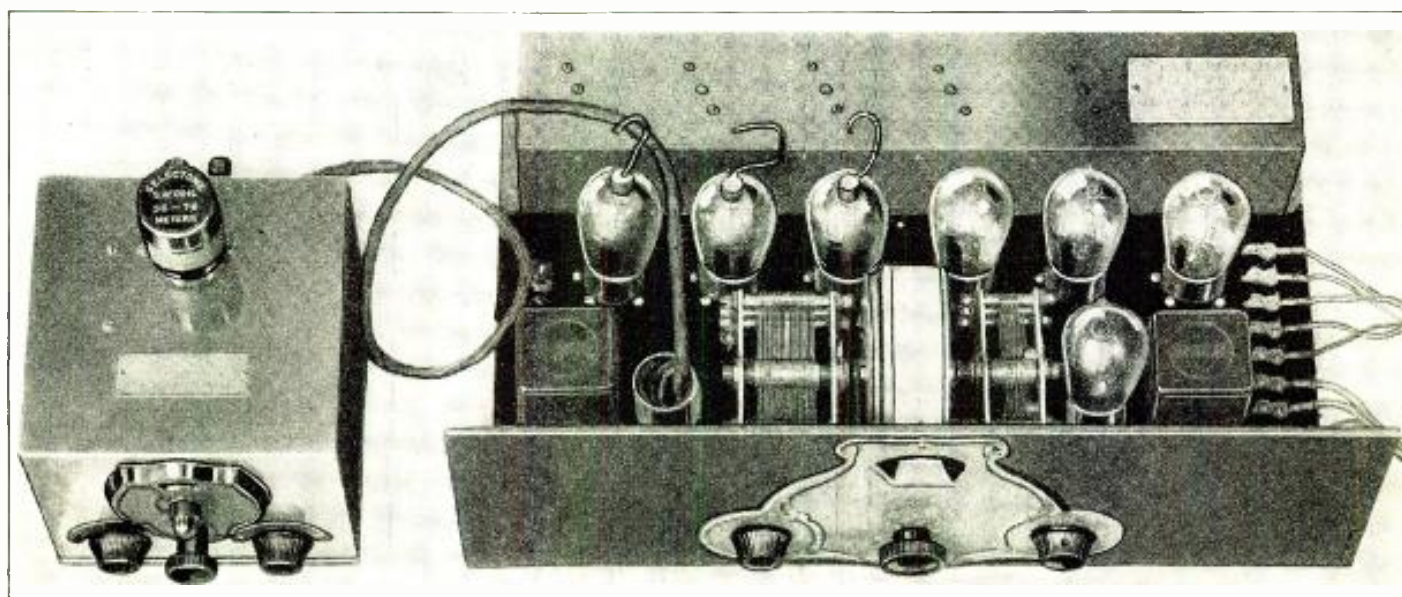

Fig. 2. In this photograph is shown the Scott screen grid a. c. 10 with the converter shown at the left plugged into the first detector socket. Be sure to remove the oscillator tube at the right of the right-hand condenser after plugging in the adapter into the first detector. In the photograph the oscillator tube was left in its socket so that readers could observe the oscillator tube position since if the tube were pulled out the socket could not be seen

Latest Amplifier Design With 245 Tubes Seen in S-M 677 Unit

*Advantage Taken of Revised Voltage Specifications of 280 Rectifier;
Supplies Complete Receiver*

THE latest design trend in amplifiers using two 245 tubes in push-pull is indicated in the S-M 677 amplifier. In this, advantage is taken of the revised voltage specifications for the 280 tube which make it possible to supply the power required for field excitation of a standard d. c. dynamic speaker and for the operation of a complete receiver or an equivalent load with a pair of 245 tubes in push-pull.

About Same Output

It is intended to meet the requirements which were formerly met by a two stage amplifier using a single 250 tube in the output stage. The two 245 tubes in push-pull provide approximately the same undistorted output and have the following advantages: the tubes themselves are much more uniform than the 250 tubes and their input impedance is high and fairly uniform so that the frequency characteristic is not seriously affected with standard production tubes. The operating voltages are lower and by using the same condensers that are used in the 250 tube amplifier a very much higher safety factor is provided at the same cost. The power tubes draw a very high percentage of the total current and in the push-pull arrangement, much less filtration is necessary since moderate amounts of a. c. ripple introduced in either the filament or plate circuit are balanced out in the output circuit. This

makes it possible to secure very much better filtration at the lower d. c. current required for the first stage and receiver tubes. Both these factors combine to make it possible to reduce the a. c. hum to about 25 per cent of that secured in a similar arrangement using a single 250 tube.

Choke in Speaker Field

In the conventional arrangement in which the speaker field is used as the first choke in the filter circuit, the amplifier hum is dependent to a large extent on the type of speaker used. Although a speaker having the proper d. c. field resistance may be used, there is a large variation in the effective inductance of the speaker field at the a. c. values found in the first section of the filter. In the S-M 677 amplifier a four henry choke is placed in series with the speaker field so that the speaker field may be entirely eliminated if necessary when using a speaker with its own field supply without excessive hum. In this case, the field supply binding post should be shunted by a 2000 ohm resistor.

Supplies 40 M.A. at 18 Volts

The amplifier supplies 40 milliamperes at 180 volts d. c. and 7 amperes at 2.5 volts a. c. and will therefore supply the current required by any tuner using four heater tubes; that is, any combination of 227's and 221's.

In addition to the radio input position which may be used with a high impedance pickup, the input transformer is supplied with a special tap intended to work out of pickups having an impedance of from 1600 to 2200 ohms. This improves the gain in the first stage and makes it unnecessary to use an impedance adjusting transformer to work out of a pickup into the usual input transformer as is the case in the conventional amplifier.

Frequency Characteristic

Working out of a 2000 ohm pickup, the frequency characteristic is flat within 2 D. B. (a barely perceptible amount) from 60 to 6000 cycles. The unusually flat characteristic at high frequencies makes it especially well suited to voice reproduction.

Designed for 712

The amplifier described in this article is designed for use principally in conjunction with the S-M 712 pre-selector tuner which is described on pages 53 and 54 of this issue. It will be noted by examining the schematic circuit of the tuner on page 54 and the schematic diagram, Fig. 2, in this article that binding posts are so arranged on both the tuner and the amplifier that connections may be easily made from one to the other.

The 2½ volt binding posts shown at

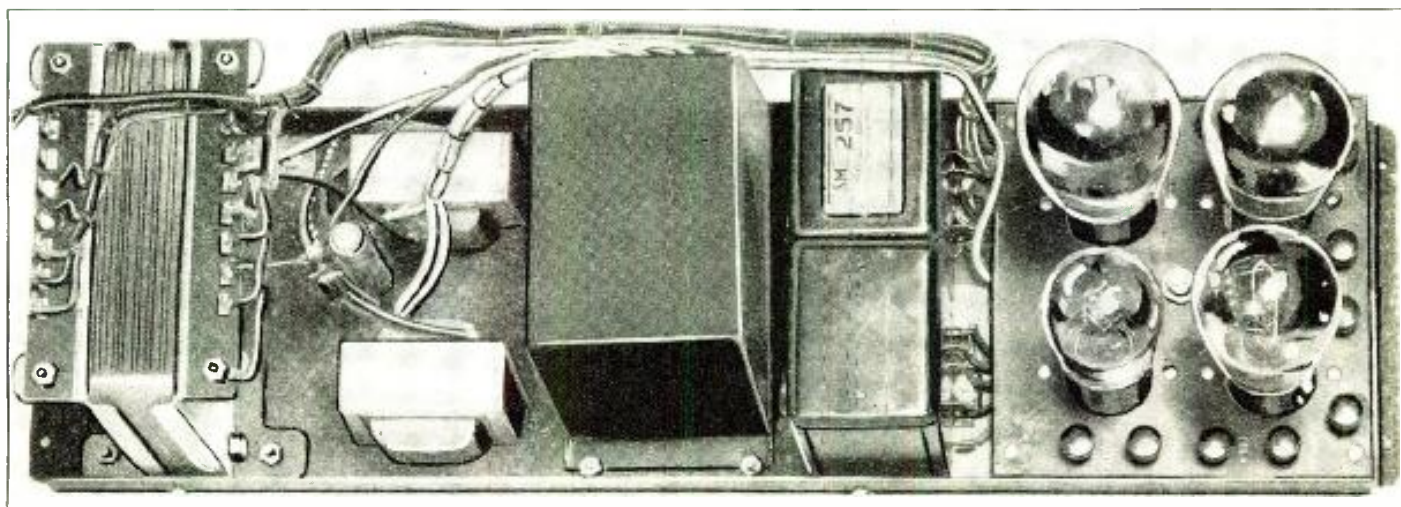

Fig. 1. The S-M 677 amplifier is shown in this photograph without the shielding cover

Screen Grid Tuned R. F. Used in Pilot Super-Wasp S. W. Set

Wavelength Range from 14 to 500 Meters and Double Shielding Features of New Kit

THOUSANDS of radio fans have assembled short-wave receivers that consist for the most part of a plain regenerative detector with one or two stages of audio amplification. A great many of them have enjoyed truly phenomenal results from their inexpensive sets, having heard broadcasting stations in England, Holland, South Africa, Central America, Australia and New Zealand. Some are able to boast of signals loud enough for loud speaker reproduction—all on two or three storage-battery tubes.

All Not Successful

However, a goodly number of these short-wave experimenters have not been so successful, their 'phone reception being confined to American stations like W8XK, W2XAD, W2XAL and a few occasional amateurs. These people for the most part have had considerable experience with broadcast receivers, and of late they have been asking a very logical question:

"Why can't short-wave sets be improved by the addition of tuned r. f. amplifiers, just as the old straight regenerators were improved several years ago for broadcast reception?"

Kruse Tackles It

The Pilot Radio & Tube Corporation decided to tackle the problem, and obtained the services of Robert S. Kruse, well known on short-wave work. He proceeded to beat down the objections offered against tuned screen-grid r. f. for short waves. They were able to produce the new set, called the "Super-Wasp," which has the following features:

1. It uses a tuned 222 radio-frequency stage that actually amplifies and

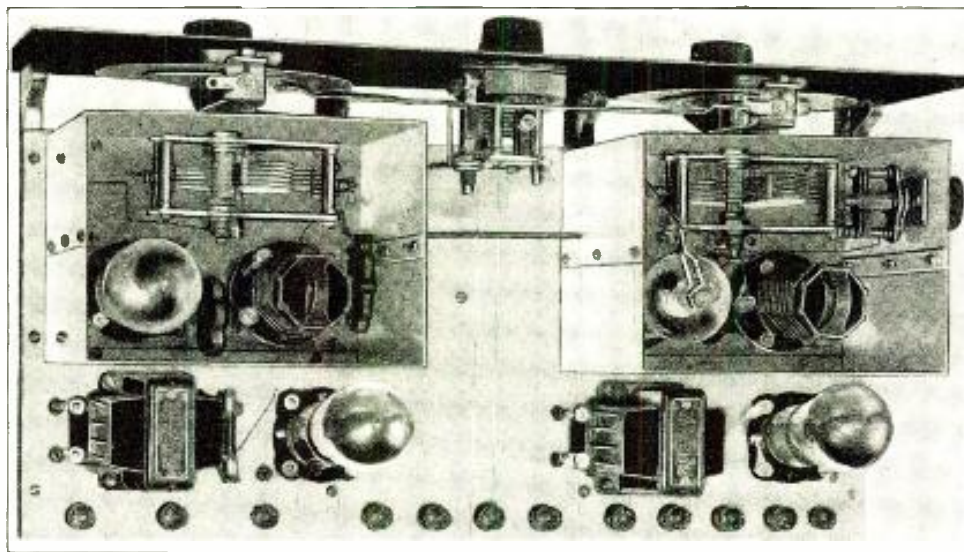

Fig. 1. This photograph shows completed Super-Wasp as built up by technicians in our laboratory

tunes. The tube is not a blocking tube, but an amplifying tube.

2. It will tune down to 14 meters and up to 500. Two sets of plug-in coils (ten coils in all) are supplied with it. Thus it is an all-round receiver, and can always be depended on to produce some signals, on some wavelengths.

3. The increased sensitivity and selectivity provided by the r. f. stage make the reception of short-wave broad-



Fig. 2. The front panel arrangement of the Pilot short wave receiver is illustrated above

casting stations easier than with a highly critical straight regenerator.

4. It is double shielded, there being no interaction between the r. f. and the detector stages.

5. There is absolutely no hand capacity effect.

By examining the accompanying diagram and illustrations one can obtain a good idea of the general electrical and mechanical arrangement. Briefly, what has been provided is this:

Constants of Set

The signals picked up by the aerial pass through the midget coupling condenser to a regular tuned input circuit connected across the grid and filament of the 222 tube. The aerial coil is a plain solenoid on a form which plugs into a five-prong tube socket, while the tuning condenser is a regular .00016 mf. variable. On each of the four small coils (the largest

tuning up to 200 meters) there is merely a single winding, one end connecting simultaneously with the G and P pins, and the other to one of the F posts. On the fifth and largest coil, which takes in the broadcast band, there is a primary in addition to the grid coil, connected to the C post and same aforementioned F post. However, the bridging wire between the G and P posts is absent.

By means of this arrangement, the aerial is coupled to the tuning coils of the four short-wave inductors through the midget condenser. This condenser is too small for the 200-500 meter region, so when the largest coil is plugged in, it is automatically cut out of the circuit and the aerial coupled to the grid coil by means of the more adequate primary winding. There are no switches to be thrown, or wires to disturb.

The plate current for the 222 tube is fed right through the detector grid coil, being kept off the grid of the detector by the grid condenser. As the rotor of the tuning condenser is grounded to the aluminum chassis of the set, the tuning circuit is completed by a .01 mf. condenser. This condenser, in series with the .00016 mf., is too large to have any appreciable effect on the tuning, but prevents the B + 135 from short-circuiting against the framework. A similar

Mississippi Valley Has Two Models of A. C. Screen Grid Supers

One Has Audio and Power Supply On Chassis, Other Is Tuning Unit for Any Power Supply

THE new Braxton-King a. c. screen grid superheterodyne manufactured by the Mississippi Valley Radio Company is supplied in two models. Both are identical as regards their r. f. circuit characteristics and operation, but whereas their model A is a complete screen grid super with the audio units and the power supply built as an integral part of the receiver, the model B is an a. c. screen grid super tuning unit, to be used in connection with any standard power supply.

A considerable amount of research work has been done in developing this receiver with the purpose in mind of producing a screen grid superheterodyne that would give an excellent degree of performance as regards both quality and sensitivity. With the present status of radio design it is no longer a question of receiving distant stations but rather a question of the quality of reception and the ease with which they are received. This factor is dependant on circuit design, the quality of the parts and the skill of workmanship. Each Braxton-King receiver is built, not as a production problem, but as an exact highly synchronized assembly that will perform permanently at top efficiency.

Careful Arrangement

A carefully planned arrangement of parts with complete shielding permits the stable employment of an extremely high gain intermediate frequency amplifying circuit. As in previous models of the Braxton-King each of the intermediate frequency transformers is tunable, a low loss 13 plate condenser being used for this purpose. The advantages of the exact matching which this tunable feature permits are readily apparent in the increased gain and selectivity with the matching condensers properly adjusted.

All of the electrical details of the circuit may be readily seen by an exami-

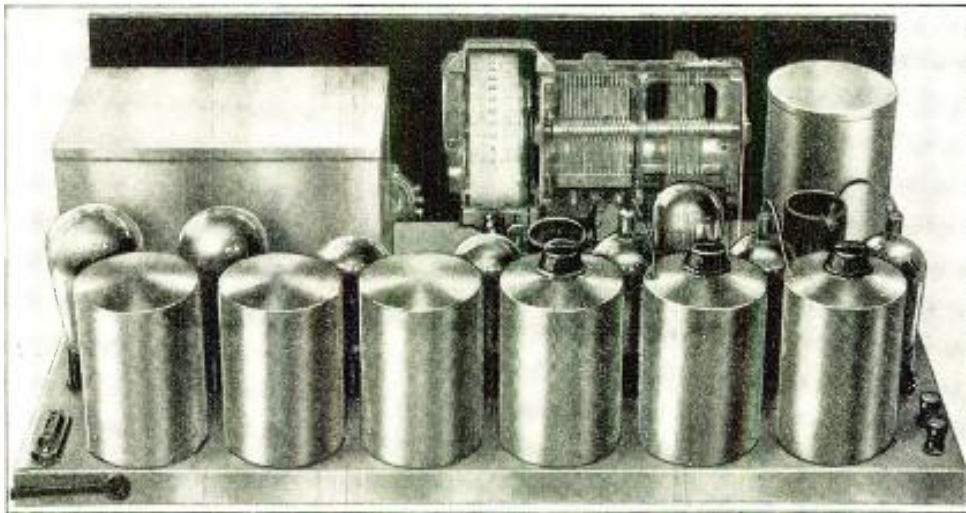

Fig. 1. This is the model A Braxton-King a. c. screen grid super

nation of the schematic diagram in Figure 3. Grid bias for all tubes is secured by the drop through individual resistors between cathode and ground, each being properly by-passed. Two of the grid bias resistors from the 224 tubes are connected in series with a variable 50,000 ohm resistor mounted on the panel of the receiver and used as a volume control. The oscillator circuit is a standard tuned-grid design with the coupling of the windings designed to give proper output and pick-up. Power detection is used for the second detector, this being of the grid bias type providing an output voltage of high degree to the audio amplifying system and giving linear detection with its freedom from harmonics.



Fig. 2. Model B shown here is an a. c. superheterodyne screen grid tuner for use with a standard power amplifier

Tuned Plate I. F.'s

The design of the intermediate frequency transformers is a marked departure from standard practice. Each unit is of the tuned-plate type, this method of tuning giving higher amplification with the 224 tube. The secondary winding is loosely coupled to the tuned primary in order that high selectivity

may be obtained, but the grid end of the secondary winding has its last four turns wound on the primary form, this winding coupling very closely to the plate end of the primary coil. A considerable increase in voltage transfer—and naturally amplification—is affected by this construction, whereas the selectivity is kept at a high degree due to the apparent loose coupling. The condensers tuning the primaries are of a low loss type and are mounted inside the shielding case with their knobs protruding through the top of case for manual adjustment. The proper adjustment of these condensers is made at the factory and the case marked to show setting. However, they should be retuned slightly by the operator in order to compensate for the particular capacities and characteristics of the tubes he is using. Proper adjustment of these matching condensers is an easy matter, as it is simply a question of adjusting to maximum volume on a distant station. Once adjusted, they should be left permanently in position. The transformers are all peaked at a frequency of 475 KC in order that there will be no repeat points on the dial.

Variometer Compensator

The antenna and oscillator coils are both space-wound on threaded bakelite tubing, the construction being of the plug-in type. All windings on the oscillator coil are fixed but the antenna coil has the grid end of its secondary continued to a variable rotor form built in

Diathermy Apparatus May Interfere Over a Broad Reception Area

Most Serious Form of Blanketing Comes From Oscillations Set Up in the Supply Lines

HIGH frequency apparatus, such as is used in the medical profession, has long been one of the most prolific sources of radio interference. Unlike the majority of electrical devices which create interference in their immediate locality only, certain types of high frequency apparatus set up interference which destroys reception over a large area. In fact, in some cases where the supply lines to the apparatus parallel the primary supply or telephone circuits, the disturbance may be spread over a considerable distance and even carried into cities several miles away.

How Interference Spreads

The interference created by this type of apparatus is distributed in several ways. Undoubtedly, the most serious form of interference is that created by oscillations set up in the supply lines to the apparatus. These oscillations will, in a great many cases, entirely blanket reception over the secondary distribution network to which the high frequency apparatus is connected. As previously mentioned, this interference may also be transferred to the primary distribution network and to telephone lines and, of course, by this means cover a much larger territory.

Another form of serious interference is that due to direct radiation from the apparatus. By this means, the interference is transferred not only to radio sets in the immediate vicinity, but also to both the primary

and secondary distribution network. The oscillations thus induced considerably augment those which, due to conductive coupling, are already present in the supply lines. The widespread distribution and intensity of the interference is due to the methods employed in obtaining the frequencies required for diathermy treatments, and to the fact that these frequencies are usually within the broadcast range. Since the apparatus used for generating these frequencies is similar to that used in the operation of spark transmitters, which are now forbidden by Federal law, the difficulty of eliminating interference from this source can readily be appreciated.

Line Filter Required

The first thought that comes to mind is that a single section inductive-capacitive type line filter would prove effective.

This is not the case, however, for several reasons. First of all, the frequency at which the apparatus is operated is not the same for all types of machine; in fact, some apparatus is provided with means whereby the frequency may be varied at the will of the operator. Second, even if a satisfactory line filter were developed, the direct magnetic radiations from the apparatus would couple with the supply wires on the line side of the filter, as well as with telephone or other wired circuits, thus minimizing the effect of the filter. This readily proves the fallacy of attempting to use a simple line filter.

The thought then presents itself that perhaps several filters might be used in various parts of the supply circuit, thus effectively preventing the distribution of interference along the supply lines. This method, however, is practical for us only when the high frequency apparatus is in a relatively isolated location, as it is of course impractical, in a congested district, to which may be in the immediate vicinity of the apparatus. Due to the intensity of the directly radiated interference, even filter every circuit the most elaborate system of line filters would be of no avail in suppressing interference under these conditions.

Shielding Necessary

As the majority of the installations of this type of apparatus are in congested districts, it is plainly evident that not only a line filter but also



Fig. 1. Here is shown an interference screen placed around the apparatus with the patient and the operator inside

†Filterette Type 1
H. F. O.

some means of suppressing the directly radiated interference must be provided. The answer to this problem is shielding.

The application of suitable shielding, however, is not the simple matter it might appear to be. The first shield constructed enclosed only the high frequency generator. This shield effectively prevented the direct radiation of energy from the machine, thus making it possible to determine the most effective type of line filter for preventing the distribution of interference along the power lines.

Single Section Ineffective

Single section filters were found to be ineffective; in fact, it was necessary to go to three sections before complete suppression of the interference was secured. Due to the complications involved in the manufacture of such a filter, further experiments were carried on, with the result a new type of line filter† was developed which was entirely satisfactory for commercial use.

With the development of the line filter which, in connection with the shield, gave satisfactory results, the apparatus was then tried in actual operation. It was found that the interference returned as soon as the machine, even though shielded, was used for treating a patient. This meant, of course, that the patient as well as the apparatus must be satisfactorily shielded.

Type of Screen

As the problem now seemed relatively simple, a screen cage sufficiently large to contain both the apparatus and the patient was constructed. This cage was constructed of copper screening bolted to an angle iron framework, and to all appearances should have been entirely satisfactory. However, upon further experimentation, it was found necessary to solder screening across all

†Filterette H. F. O. used.

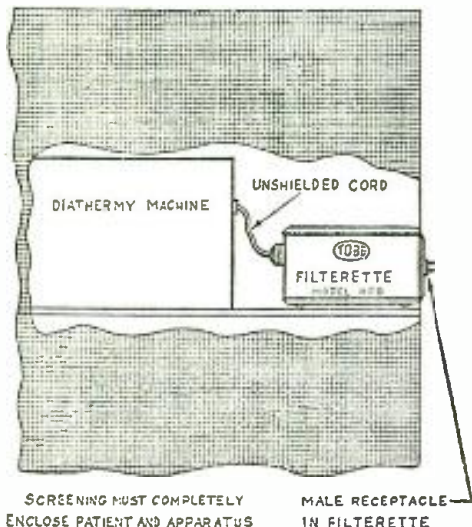

Fig. 2. This shows how the filter is built directly into the screening

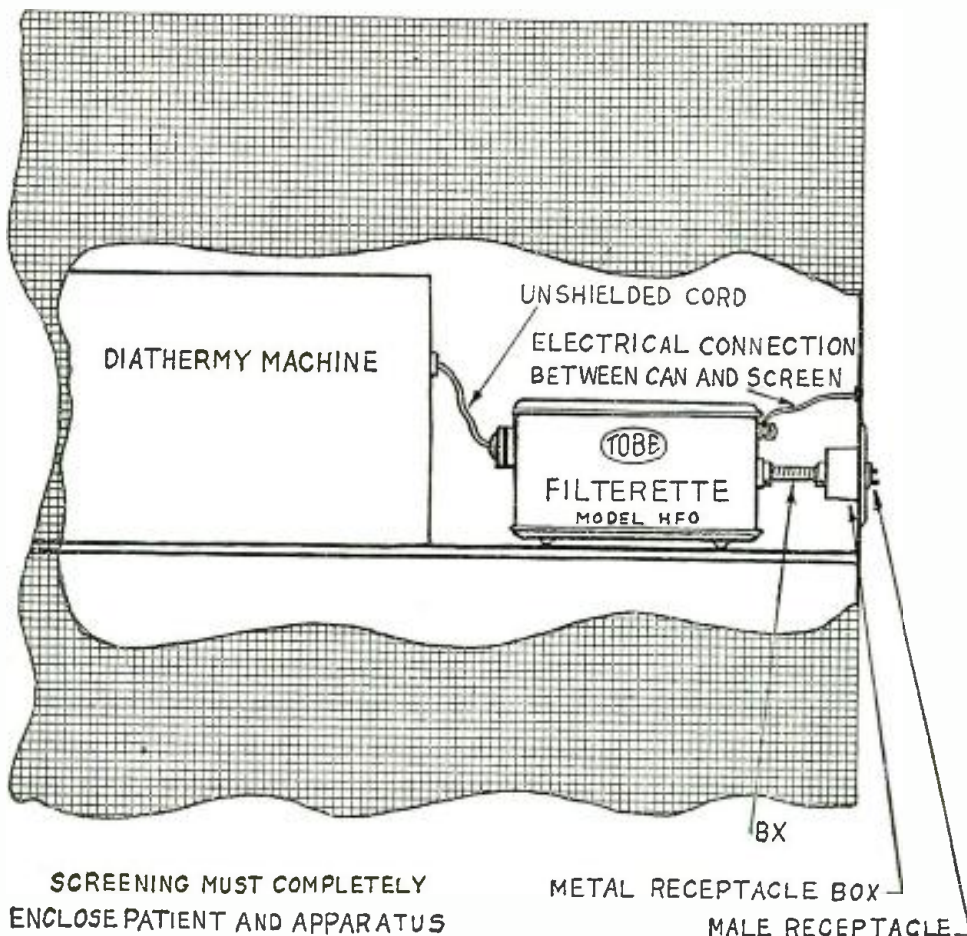

Fig. 3. Enlarged view of the method of building the filter into the screening

the joints in the angle iron framework in order to prevent radiation. As this construction was quite complicated, a third shield was constructed.

In the construction of the third shield, copper screening was again used. A wood frame, however, was substituted for the iron, and the screening was so arranged that firm metallic contact was maintained between screen sections. This shield proved entirely satisfactory.

A fourth screen was constructed on the same principle as previously employed, with the exception that galvanized iron screening was used in place of copper screening. This screen was more satisfactory than the copper screen.

After having finally secured a combination of shield and filter which was satisfactory, further experimentation was carried on in order to determine what precautions were necessary for the satisfactory operation of this equipment.

Further Precautions

First of all, it was found that although with some types of apparatus the door to the cage could be left open without creating serious interference, with other types of apparatus it was necessary to have a complete metallic contact between door edges and cage to secure satisfactory shielding.

Second, it was found that if a drop light were run into the cage, the cord to the light must be completely shielded, and the shield connected to the cage, or

the interference would be distributed through the lighting circuit. This was also true of any bell wires running into the cage; in fact, it was found that absolutely no wiring of any description could be carried through the cage if complete suppression of interference were to be obtained.

Built into Screen

Third, in attaching the filter it was found necessary either to build the filter directly into the screening, as in Fig. 2, or to run the supply wire to the filter in BX or conduit as in Fig. 3, and to attach the latter to the screening. If this were not done, or if a long supply wire were used, even though this wire were run in BX, the shielding was rendered ineffective.

In conclusion, it would appear that although a line filter alone may provide satisfactory suppression of the interference in isolated installations, or where no receivers are operated in the immediate vicinity of the apparatus, this is not always the case. In fact, it is essential that both filtering of the supply line, and complete screening of patient and apparatus, be employed if satisfactory radio reception is to be obtained within several hundred feet of the apparatus.

Helpful Data Available

Readers interested in interference elimination may secure helpful data from the Tobe Deutschmann Corp.

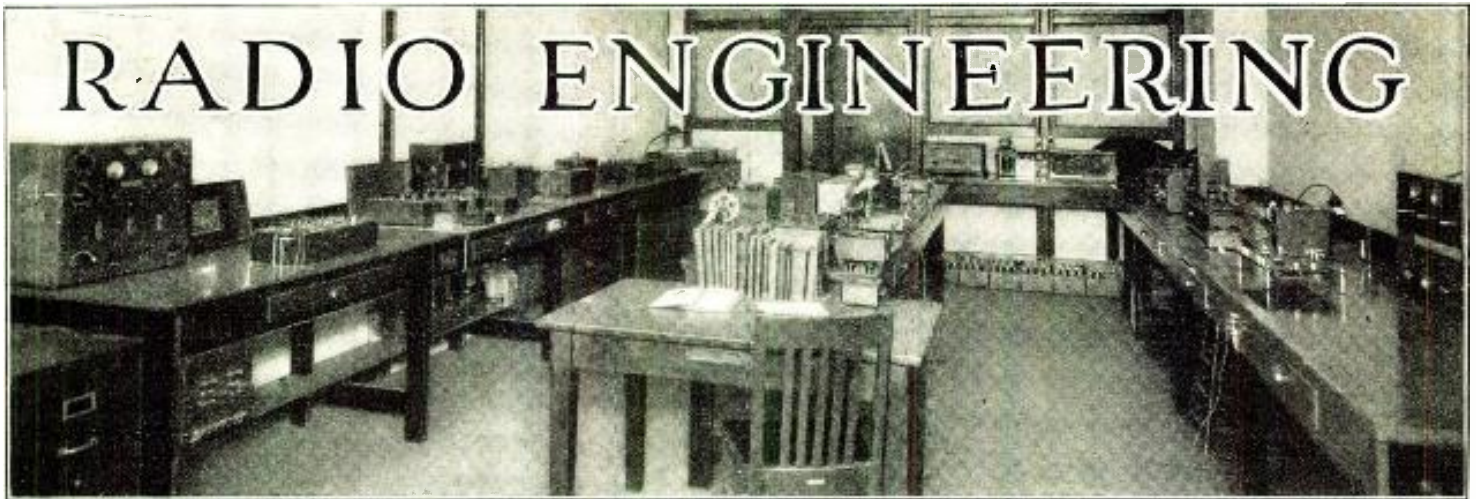

Interesting Thoughts From Engineers On Use of Power Detection

*Diversity of Opinion Concerning 227 and 224 Exists in Industry;
Reader Gets Benefit of Views*

[Ever since the introduction of the 227 and the 224 a wide variety of opinions has been expressed by radio engineers concerning the possibility of using these tubes as power detectors in modern circuits. In keeping with our policy of throwing the columns of this section open to radio engineers for the presentation of their views within the scope of this section, we are printing a number of contributions from engineers well known in the field. We feel certain our readers will be glad to know every phase of the subject under discussion.—Editor.]

By **Byron B. Minnium**

Chief Research Engineer, Stewart-Warner Corporation

THE use of the 224 or 227 (or any other tube, for that matter) as a so-called "power" detector seems clothed in a certain amount of mystery to the average radio fan. Actually the matter is quite a simple one: the advantages and disadvantages of this form of detector, as compared with the grid-condenser grid-leak type, may be briefly stated; and the choice of tube is simply a matter of what the designer wishes to accomplish.

Compared with the grid-condenser grid-leak (hereafter called grid-circuit) detector, the biased (or plate-

circuit) detector, when operated at sufficiently high steady grid and plate voltages, has the following advantages: First, ability to handle more signal energy before the point of overloading is reached; and second, less distortion, especially on highly modulated carrier waves. Its outstanding disadvantages are: First, its relatively high plate impedance, resulting in greater difficulty in coupling it to the tube following it; and second, its low sensitivity. These points will be discussed in detail later.

Swinging Power Tube Grid

The required amount of audio amplification (that which follows detection) obviously depends upon how much power the detector will handle without perceptible distortion. Stated another way, the problem is this: with a signal of sufficient strength to almost overload the detector, we must have at least enough audio-frequency gain to swing the grid of the power tube over its maximum operating range.

With grid-circuit detection, the detector output is quite limited and we ordinarily employ two audio stages in which the inter-tube coupling transformer ratio is from two to four, depending upon the power tube used and other considerations.

Plate circuit detection, when the plate and grid voltages are high enough to constitute so-called "power" detection, allows much greater detector output than does grid-circuit detection and,

for that reason, is ordinarily employed with only one audio stage; or, if two stages are used, the voltage gain per stage is made quite low. The reason for this is obvious because, starting with more power from the detector, we need to amplify it less in order to have a signal of a given magnitude applied to the grid of the power tube.

Now it is plain that, even with "power" detection, we could still use the same amount of audio gain as is used with grid-circuit detection. In doing so, we would simply not work the detector to its limit when fully loading the power tube. This would not be at all undesirable; but for another reason, it is not in line with good design.

Limit Total Gain

Since hum originating in the detector tube is amplified by the succeeding audio stages, it is desirable, *from this standpoint*, to limit the total audio gain to the *least* value which will allow the power tube to be worked to its maximum without perceptible overloading of the detector.

With low audio gain and low detecting efficiency, the over-all sensitivity of our radio receiver will be necessarily low, unless we compensate for it by increasing the gain in the r. f. amplifier. The advent of the screen-grid tube has allowed us to do this. In fact we can more than compensate for the shortcomings of our new detector-audio system and secure even *better* over-all sen-

sitivity than we had with the former system.

The ability to handle highly-modulated carrier waves permits broadcasting stations to increase their degree of modulation, thereby increasing their transmitting range with the same amount of energy radiated in the carrier wave.

Two Factors Govern Choice

The choice between the 224 and 227 tubes as "power" detectors is mainly dependent upon two factors: First, the 224 has a higher detecting efficiency because of its higher amplification factor. Therefore it is correspondingly easier to work the power tube to its limit without overloading the detector. Furthermore, the r. f. end of the receiver is not so heavily burdened in making up for the lack of amplification of the detector-audio-amplifier combination. Second, the 224 has a much higher plate impedance than the 227 and it is therefore more difficult to properly couple it to the power tube, unless resistance or impedance coupling is used—which prevents the use of "push-pull" in the power stage.

The argument usually put forward that we use "power" detectors because of the high gain in modern r. f. amplifiers is, of course, fallacious. The truth is that such high gain r. f. amplifiers permit the use of low-sensitivity "power" detector and their associated low-gain audio systems in spite of this one disadvantage and in order to obtain the benefits of their advantages mentioned above.

By McMurdo Silver

President, Silver-Marshall Co.

DUE to the demand for high quality reproduction of material broadcast by stations using high percentage modulations, manufacturers of radio receivers have been adopting the power detector as a feature of their sets. Either the 227 or 224 tube may be used for this purpose. There are several advantages in using the 224 type tube. For a given input in r. f. volts and a given percentage modulation frequency the voltage across the output circuit for the 224 may be as much as twenty-five times the output of the 227 type tube used similarly. So, although it is possible to use a step up transformer working out of a 227 which is not feasible with the 224, an equal overall gain is not possible, due to the practical limit on the transformation ratio possible with the 227 type tube. The high impedance of a 227 tube used as a power detector limits the practical ratio of transformation to less than 1 to 5. Even with such a ratio, the high and low frequencies are considerably attenu-

ated. It is, therefore, clear that, from the standpoint of sensitivity and fidelity in reproduction, a 224 used as a power detector has a decided advantage over a 227 tube.

By A. Crossley

Chief Engineer, Howard Radio Co.

BRIEFLY, the writer is of the opinion that the 227 tube is to be preferred as a power detector tube because, first, of the difference in price, second, the tube has been accepted after years of good service and third, the plate impedance of this type is such that it can be used very efficiently with the existing types of transformers now standard on the market. The 224 type of detector tube has too high a plate impedance to be used with the regular type of iron core audio frequency transformer and it is necessary to provide additional equipment to obtain the maximum power transfer from 224 tube to first audio frequency amplifying system.

The use of the 224 tube complicates the wiring of a receiver and there is not enough difference in efficiency between either of the tubes to warrant the additional expense of using the 224 tube.

By Ray H. Manson

Vice President and Chief Engineer, Stromberg-Carlson Telephone Mfg. Co.

REGARDING comments on the use of the 227 vs. 224 vacuum tubes as a power detector, this is a subject which is under controversy and is dependent upon the general plan selected by the designer of a radio receiver. If there is a high gain in the radio frequency amplifier and the audio amplifier has certain characteristics, it is satisfactory to use the UY-227 tube as a detector. On the other hand, there are conditions which will allow satisfactory use of the UY-224 tube as a detector. However, careful engineering studies of the complete receiver disclose the following:

1—That the overload characteristics of the UY-224 are not as good as the UY-227.

2—That there is difficulty in making use of the available audio voltage of the detector plate circuit of the UY-224 tube when coupled to present designs of audio amplifiers, particularly push-pull amplifiers.

3—There is danger of sacrificing audio quality when the UY-224 is used as a detector, due to the fact that it is difficult to provide the necessary high impedance circuit into which this tube must work, otherwise the low audio frequencies are badly cut.

The above statements are not complete and are taken at random to show some of the factors which enter into the problem of using the UY-224 as a power detector and which are not present when using the UY-227 as a power detector.

By E. K. Oxner

Chief Engineer, High Frequency Laboratories

WE have had little or no experience with the 227 as a detector with the extremely high negative grid bias such as is now in quite common use; viz., plate circuit conditions, together with grid circuit arrangement producing grid values up to 50 volts negative.

We have made a great many receivers with the 227 as a so-called plate rectification detector with a specially high impedance transformer for a plate load (43 henries at 60 cycles) with control bias of the order of 15 volts. This, of course, does not produce the sufficiently large plate current swing necessary, in our opinion, for the proper use of a single audio stage without overloading.

Bias at No-Signal Level

As for the 224, we are quite in agreement with the manufacturers' recommendation, i. e., that the tube be biased to produce a no-signal plate current of one-tenth m. a. This can be secured with a variety of different combinations of B voltage and K-G resistor. We have not, however, noticed any indication of internal disintegration of which the manufacturers warn with differences of potential between H and K as high as 20 volts, with K positive. This value we are now using and expect to continue with it for the present.

By F. J. Marco

Chief Engineer, Audiola Radio Co.

IREGRET that I am unable to give you any more and complete information regarding the relative merits of the 224 and the 227 tubes as power detectors other than the brief statement concerning Audiola's employment of the 227 at a plate voltage of 180, C bias voltage of 15, plate current .1 m. a. and the plate coupling resistor being of 100,000 ohms.

We do not use the 224 tube as a power detector in any of our models although we have one receiver which utilizes the 227 in a more or less conventional manner. Our laboratories have not done a great deal of experimental work with 224's in this capacity as yet, mainly due to the pressure of production, although I firmly believe

that the tube holds forth a great deal of promise when correctly used.

224 Overloads Easily

I believe that you should point out to your readers the great disadvantage of improper use of the 224 as a power detector when an inappropriate grid bias is used. This tube due to its necessarily low control grid bias as compared to the 227 will overload much more easily on a signal of high amplitude and, therefore, produce the usual "double hump" resonance curve.

By **R. H. Langley**

Director of Engineering, Crosley Radio Corp.

EVERYONE who has given the matter any thought admits that the screen grid tube is a logical and valuable new contribution to radio receiving sets. It eliminates that small feed-back capacity between plate and grid which was the outstanding defect of the three element tubes. All the work that was done to develop methods of balancing, all the neutralizing methods, all the complicated transformers and condensers and wiring, all the careful balancing and re-balancing of the sets, is swept into history by the screen grid tube.

It would seem as if this alone was sufficient reason for using the new tube in the sets that we build today. There are those, however, who hesitate about it. They ask questions about life and uniformity, and wonder whether it would not be the part of wisdom to stick to the tried and proven three element tube. It is the same old story of those for whom the march of progress is too swift. But their questions can be answered, and their doubts will soon be resolved.

Same Filament System

The filament system in the screen grid tube is exactly the same as it was in the well established heater type tube. This answers any question about life. So far as uniformity is concerned, it is perhaps true that the new tube may show a somewhat greater variation for the next few months. But it was the variation in that troublesome feed-back capacity in the old tubes that really caused the trouble, and in the new tubes this capacity has been reduced to a negligible value.

No one claims, of course, that the tremendous amplification of which the new tube is capable, can actually be utilized in a broadcast receiver. No one would want a receiver ten or twenty times as sensitive as last year's models. They were powerful enough to reach down to signals no stronger than the

static and noise on a cold winter night, and any greater sensitivity would be useless.

Makes Better Receiver

But the greater amplification of the screen grid tube can nevertheless be very effectively used to make a much better receiver. With it, it is possible to get considerably greater gain in the radio frequency portion of the set, and thus to cut down on the audio amplification which is needed. This permits the use of resistance coupled audio stages, which give a tremendous advantage in the quality of reproduction. It also permits the use of the bias type of detector, instead of the grid-leak type, which is another great step in the direction of good quality. Both of these features were the dream of set designers years ago, but never until the screen grid tube came, was it possible to utilize them.

Because the tube itself gives greater amplification, it is not necessary to use such high ratios in the radio frequency transformers. This makes possible the use of types of transformers that give practically uniform gain and uniform selectivity over the whole range of broadcast frequencies. Thus while last year's set was quite sensitive in the middle of the dial, and relatively weak at one end or both, the new screen grid

sets are sensitive and selective over the entire dial.

Many Parts Eliminated

Radio frequency transformers for the three element tubes had to have three windings. The third winding was for balancing the feed-back capacity, and with it was associated the troublesome balancing condenser. All these parts are gone in the screen grid set. The saving in parts and wiring complication alone is important, but when it is remembered that these additional parts were tacked onto the tuned circuits, and contributed these losses to cut down amplification and selectivity, the advantages of screen grid tube become more apparent than ever.

The set of today and tomorrow uses screen grid tubes. It is perhaps the most important contribution yet made to broadcast reception.

Wise with Sylvania

ROGER M. WISE for seven years chief engineer of E. T. Cunningham Inc. now occupies a similar position with Sylvania Products Company. This became effective August 1.

Mr. Wise is one of the foremost of radio engineers and his experience embraces fifteen years of intimate contact with every phase of radio activity.

Production Testing of Audio Frequency Amplifiers

By **ARTHUR E. THIESSEN**

(Engineering Dept. General Radio Co.)

HOWEVER much engineering development the manufacturer of an audio-frequency amplifier expends on its design, there remains the problem of comparing the performance of the quantity-produced unit with that of the laboratory model. Without rigorous inspection some defective units

are likely to reach the user, which makes necessary expensive replacements and breeds ruinous ill will.

Some manufacturers check the component parts before assembly and follow this with a supplementary "try-it-and-see-if-it-works" test. This, however, is only partially satisfactory because errors in assembly may still creep in and because any kind of a trial inspection requires highly-competent, specially-trained inspectors if the tests are to mean anything. Even then, it is doubtful whether any listening test can be relied upon to detect small abnormalities in the performance of a high-quality amplifier under production conditions.

When preparing to manufacture their new radio receivers, the Victor Talking Machine Company realized the importance of thorough inspection and the limitations of the usual methods. They



Fig. 1. Audio amplifier test set as built by General Radio for the Victor Talking Machine Co.

asked the General Radio Company to build suitable test equipment, and the engineering departments of the two organizations collaborated on the design of the audio-frequency amplifier test

voltages at each of five selected frequencies (40, 100, 400, 2500, and 6500 cycles) covering the audio-frequency band. At each of these frequencies the voltage of the oscillator is made the

decibels. The voltmeter is the one in the center of the panel.

The input and output networks for making the overload-level test are controlled by the other hand-wheel. As its pointer is moved from left to right in ten successive steps, an attenuation of two decibels per step is removed ahead of the amplifier, and, simultaneously, the same amount is inserted in the output circuit. So long as the amplifier is operating below its overload level, the reading of the voltmeter remains fixed, but, when overload occurs, further increases of input fail to produce proportional increases in the output power. Thus, the overload level is indicated when the output voltage begins to drop off as the test switch is advanced.

In testing an amplifier under working conditions, it is merely necessary to connect it to the test panel by means of a set of flexible leads. With the overload-level switch set at zero the gain test is made at each of the five test frequencies, and, if the reading of the output voltmeter does not deviate from standard by more than a specified tolerance, the amplifier has been shown to have a gain-frequency characteristic like that of the laboratory model. The next step is to set the frequency control at some point—400 cycles, for example—and to advance the overload-level switch until the output voltage begins to fall off. The setting of the switch where this occurs indicates in decibels the overload-level of the amplifier referred to the reference level.

At the extreme lower right of the panel, next to the toggle switch for controlling the power supply to the test set, may be seen two key switches. One of these throws the voltmeter from the amplifier output circuit to the output of the oscillator for checking its voltage.

Since the audio amplifier is intended for use in conjunction with a phonograph pickup (low impedance) as well as the detector tube of the radio receiver, its input circuit has a low- as well as a high-impedance winding. Gain and overload-level tests are made for each winding, and the second key switch makes the necessary internal changes in the test panel.

By means of this extremely rapid check practically all of the possible errors in construction will have been shown up. When the first production-built amplifiers were being tested, several were found to have a sub-normal amount of gain in the middle of the frequency band. Checking them upon the elaborate laboratory gain-measuring set proved that the test panels were operating correctly, but the trouble could not be traced to any fault in the amplifier until it was discovered that

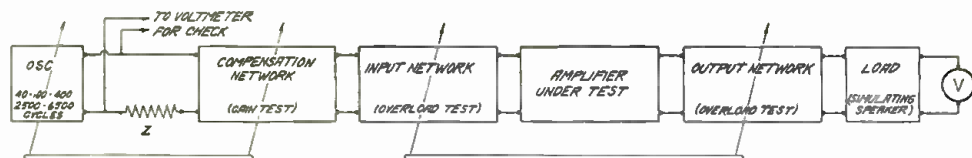

Fig. 2. Schematic of the test panel for making rapid measurements of gain and overload level in amplifiers

set that is described here. It makes possible a speedy and accurate test and is capable of operation by an inspector with no special training.

The most important characteristics of an amplifier's performance are its ability to show the required amount of gain or amplification over the desired frequency range and to deliver the required amount of power without overloading. It was decided that the test of the Victor Company's amplifiers should include an accurate measurement of both these quantities.

The method chosen for making the test for gain is based upon one sometimes used for making measurements in the laboratory. Figure 1 shows it in schematic form. An oscillator operating at the test frequency supplies energy through a calibrated attenuation network to the amplifier, in the output circuit of which is connected a suitable load and a meter for measuring the voltage drop across it. The network is adjusted until the voltage across the load is equal to that measured across the input terminals of the network. Then, if all the terminal impedances between units in the circuit have been properly matched,* the gain of the amplifier is equal to the attenuation or loss in the network. The complete gain-frequency characteristics is obtained by repeating this measurement at as many test frequencies as necessary.

The overload-level test is also based upon a laboratory method for determining where further increases in the input of the amplifier fail to produce proportional increases in the power output. The overload-level is the ratio (expressed in decibels) of this power output to the standard reference level or normal test output† of 50 milliwatts.

The audio test panels as constructed are shown in the schematic diagram of Figure 2. A Hartley oscillator delivers

same by an adjustment of the respective feed-back resistances.

From the standpoint of the inspector using the test set, it is desirable that the power output of the amplifier be constant at every one of the test frequencies, in spite of the fact that the amplifier gain is different for each one. Then

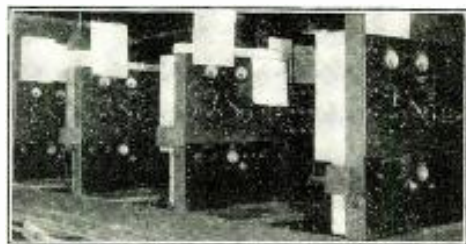

Fig. 3. Four of the six audio amplifier test panels as used by Victor for making production inspection tests on completed amplifiers

it is only necessary for him to note whether or not the load voltmeter deviates from a fixed value marked upon the dial in order to tell whether or not the amplifier is up to standard. This is accomplished by inserting enough attenuation ahead of the amplifier to make the output the same at each frequency. This is the function of the compensation network shown in Figure 2. Both the frequency change and the throwing in of the proper compensation network are made by means of the large handwheel at the left of the panel shown in Figure 3.

An alternating-current-operated vacuum-tube voltmeter is used to measure the voltage across the load and to check occasionally the output voltage of the oscillator. It is sufficiently sensitive to indicate deviations of amplifier gain from normal by as little as one or two

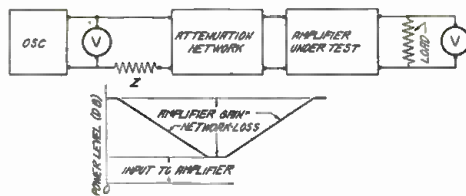

Fig. 4. Outline chart and power level diagram for the gain measuring method used in the amplifier test set. All impedances are assumed to be matched

*This requirement makes necessary the impedance Z . If the oscillator output voltage be maintained constant as shown by the voltmeter, the network behaves as though it were working out of a power source of constant internal electromotive force and internal impedance Z . See K. S. Johnson, *Transmission Circuits for Telephonic Communications* (New York: D. Van Nostrand Co., 1925), Chapter 8, in particular.

†H. R. E. Standard. See *Year Book of the Institute of Radio Engineers* (New York, 1929), p. 107.

the lower-grade wax used for impregnating the power transformers had been inadvertently used in the inter-stage coupling transformers. It is highly probable that a simple listening test would not have found the trouble, yet the accident is one that could happen in any assembly plant.

By the use of the General Radio Company's test panels, the Victor Company makes its production with great speed and accuracy and with a consequently low unit cost of test. The average time necessary for a complete check is about one minute, and the amount of deviation from standard is held to a tolerance of one and one-half decibels. This test compares favorably in accuracy with the more elaborate laboratory measurements requiring considerably more time, equipment, and technical skill. Such high accuracy is justified, for there is no excuse for the manufacturer making heavy investments in research and quality materials unless he is sure that the finished amplifier is as good as the approved laboratory model.

In addition to the check upon the completed amplifier, all of the component raw materials are tested before assembly. All input, inter-stage, and output coupling transformers are inserted in amplifiers of known excellence which are then tested on the test panel. If the amplifier shows normal performance, the transformers are shown to be satisfactory.

Ten of these amplifier test panels have been built for the Victor Company and five more are now in process.

The flexibility of the test set makes it adaptable for use with almost any audio-frequency amplifier, and it may be readily altered to take care of such changes in the design of the amplifier that may be made after production has begun. The method of working out the problem is general enough to show definitely that laboratory methods can successfully be applied to production tests.

New Rating on 280

SYLVANIA Products Company of Emporium, Pa., makers of Sylvania radio tubes, announce a new rating for the SX-280 rectifier tube.

This tube may be operated with as much as 40 volts a. c. applied to each plate of the tube, providing the current drain does not exceed 110 milliamperes. This will allow considerably higher d. c. voltages to be obtained for operation of power tubes.

This change has been made possible because most receivers do not require the maximum output current of the tube which is 125 milliamperes. If more than 110 milliamperes is required, it is best to limit the applied a. c. volt-

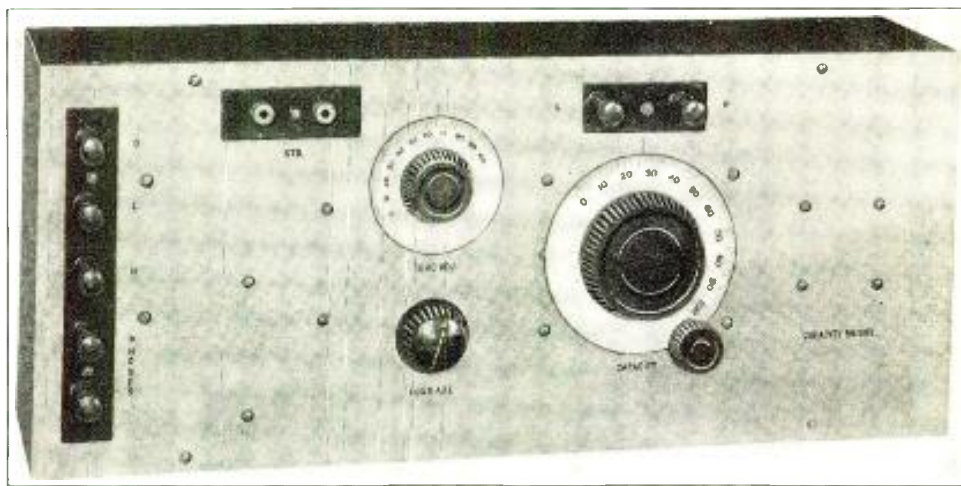

Fig. 1. Front panel view of the completed capacity bridge

age to 350 volts per plate if satisfactory life is desired.

Extensive life tests have been conducted for several months before this new rating has been approved.

Screen Grid Recommendation

THE following changes in operating voltages employed with the Sylvania SY-224 tube are recommended.

The control grid negative bias should be increased from 1½ volts to 2½ volts, while the screen-grid voltage should be raised from 75 volts to 90 volts.

The control grid bias voltage is increased so that a larger grid swing may be handled, especially in the third r. f. stage, without overloading taking place. This will prevent to a large extent carrier modulation. The loss in gain due to increasing the control bias is compensated for by increasing the screen-grid voltage. The plate current will be increased slightly.

If the potential of the screen-grid is varied to control volume it is very necessary that a "bleeder" or shunt resistance be employed to furnish a larger part of the current which flows through

the biasing resistor so that the bias will remain constant regardless of volume control position.

Making a Capacity Bridge

By R. K. PEW
(Technical Editor)

THE service man, the set builder and the repair man very often find the need of a capacity bridge quite helpful whether in the repairing, building or designing of radio equipment.

At the present time the capacity

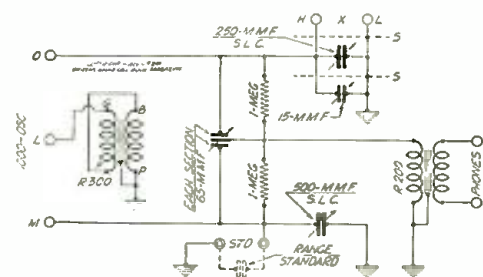

NOTE—IT IS ESSENTIAL THAT THE GENERAL RADIO TYPE 218 AUDIO OSCILLATOR BE USED WITH THIS BRIDGE, & THAT TRANS. R.300 BE CONNECTED AS SHOWN.

Fig. 2. Schematic circuit used in wiring up the job

bridges which are available on the open market do not have a capacity range

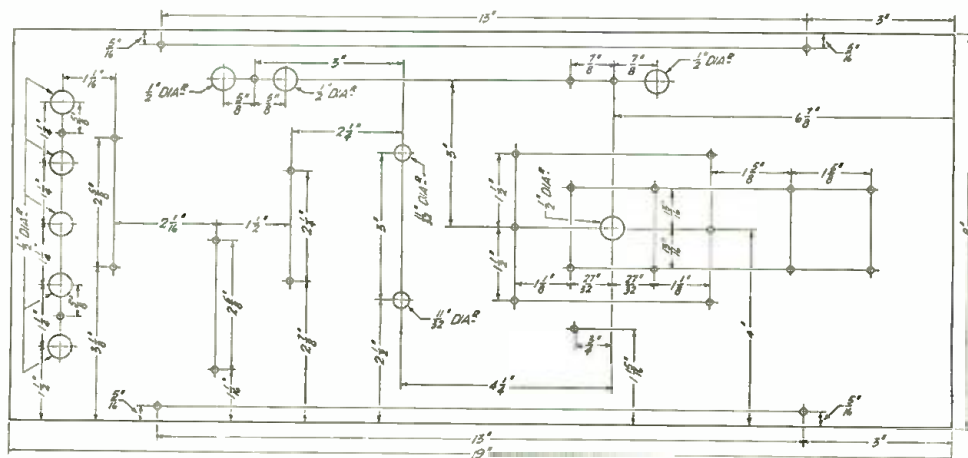

NOTE—UNLESS OTHERWISE SPECIFIED, ALL HOLES ARE 3/16" DRILL.

Fig. 3. Panel layout with all dimensions is shown here. It should be followed religiously for accuracy

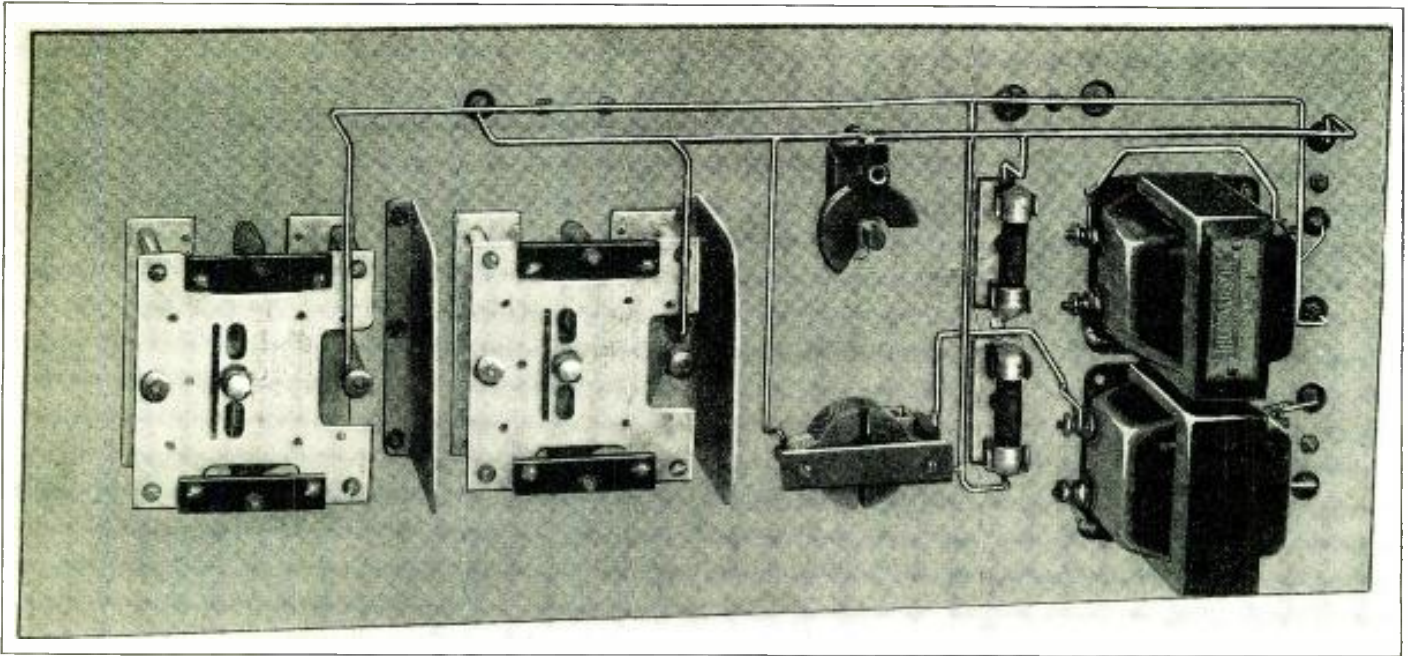

Fig. 4. This picture shows a rear view of the capacity bridge

which is entirely suitable for the uses of the service man, set builder or experimenter. Those capacity bridges which do have suitable ranges for this type of work also have a purchase price which is almost prohibitive to the service man, set builder or experimenter. For these reasons it was considered advisable to design, construct and publish the details of a capacity bridge which would have a range suitable for these purposes with an accuracy great enough to be entirely dependable for the problems at hand; also for the price to be within the means of the average fan.

In the design of the capacity bridge for the use in the average non-designing laboratory, there had to be considered accuracy, speed and rapidity of operation, simplicity of construction and parts. It is believed the capacity

bridge herewith described fulfills the requirements to such an extent that it would be a very desirable instrument in any of the aforementioned classes of work.

May Increase Range

The lowest capacity which is possible to be measured on this bridge is approximately .0000024 micro-farads. Then by the use of four range standards the range may be increased to approximately .01 mfd. It would be quite possible to increase this range to 1, 2, 3 or 4 mfd but it is very difficult to obtain standards with little enough variation that could be used with the .00025 mfd variable in the bridge. Also the power factor of the majority of bypass condensers is sufficiently high that a correct null point would be difficult to obtain in most cases. Therefore, we

have not increased this range to cover the high value of condensers. Furthermore the absolute capacity of bypass and filter condensers in the usual radio circuit is not critical enough to warrant the addition of the range standard which would prove undoubtedly very expensive.

The circuit of this bridge as will be noted in the schematic diagram in Fig. 2 is of the typical Wheatstone type and uses the capacity substitution method, the bridge being fed by a 1000 cycle oscillator and a null point being obtained by the use of head phones in the output circuit of the bridge. In order that the bridge be direct reading or nearly so it is quite necessary that that variable condenser be of straight line capacity or as nearly so as possible. It should also have as low a power factor and phase angle as pos-

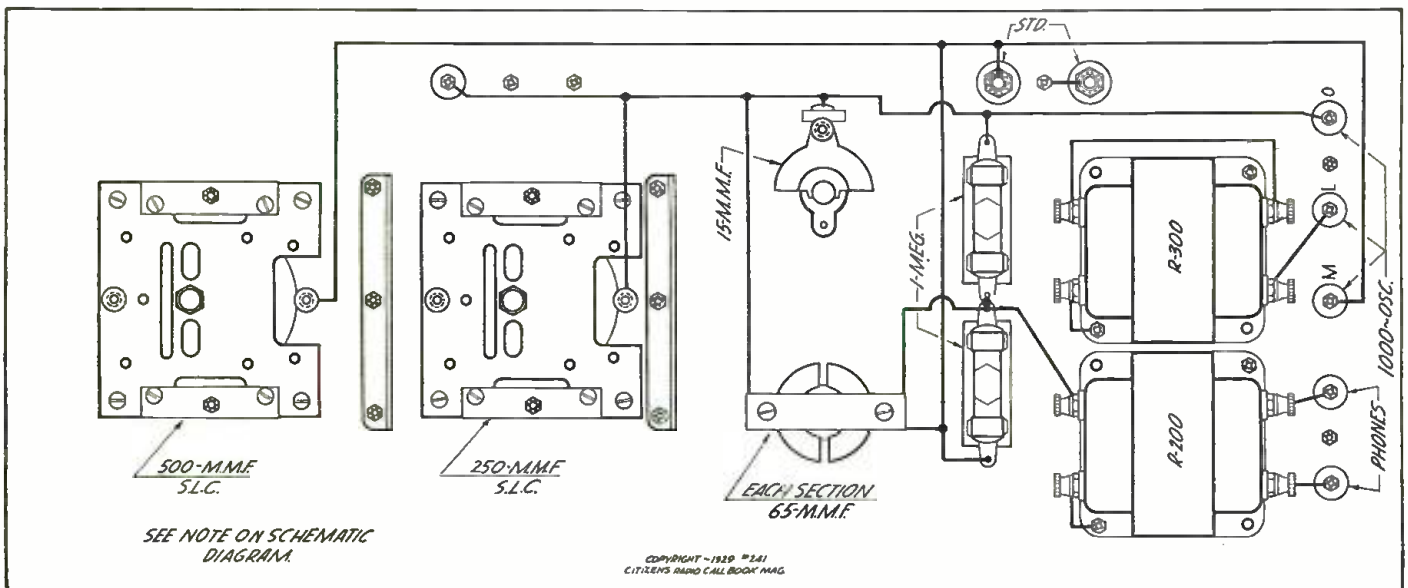

Fig. 5. A graphic drawing of the parts and the wiring is illustrated above

sible. For these reasons the National condensers have been picked. It will be noted that one, which is the variable, is .00025 mfd capacity and the semi-fixed standard is .0005 mfd capacity; the coupling transformer is the Thordarson R-300 and the telephone coupling transformer is the Thordarson R-200. In reference to these two condensers and the two transformers it is absolutely imperative that these particular makes and types be used in this bridge, otherwise it may not be possible to get a satisfactory null point, the panel will be "hot" and the capacity readings may not be in accord with the object of this design. The zero balance condenser and the loss adjustment condenser, the grid leaks and the grid leak clips, binding posts, etc., may be readily substituted if so desired, but if other than these are substituted the accuracy of the results obtained when these substitutions are made cannot be guaranteed.

Follow Dimensions Carefully

It will be noted that there is a panel layout drawing and a graphic wiring diagram and details of dimensions for the laying out of this panel. We wish to advise very strongly that this bridge be constructed from these drawings and every part and every dimension copied exactly.

It is also necessary to use a General Radio type 213 1000 cycle audio oscillator with this bridge connected as is shown in the drawing. No other oscillator or system of connections will operate at all satisfactorily.

The theory of operation of any Wheatstone bridge is that if a voltage is applied across one side of the bridge and all four sides or any two adjacent sides are equal, no current will flow in the opposite side of the bridge. Therefore, if the 1000 cycle note is impressed on the input of the bridge and the bridge is in balance, no current will flow in the output, therefore no signal will be heard in the 'phones. The method of operating this bridge is to balance the bridge for zero or minimum capacity. Therefore, if a capacity is added to any one arm of the bridge it will be thrown out of balance and the signal will be heard until the opposite arm has sufficient capacity added to balance the bridge. There has been placed on both sides of the variable condenser a shield. The purpose of these shields is so that when the rotor is turned the capacity coupling between the standard condenser and the two adjacent condensers will remain constant.

The loss adjustment condenser was constructed from two Hammarlund 65 mmf midget condensers. This is very

readily done by the removing of the stator from one of the condensers and connecting it to the other stator by means of the bakelite strip running across the bottom of the two stators and being fastened by 6/32 machine screws into the holes already provided in the bottom of the stator shafts. The panel as used is of aluminum approximately 3/16 in. thick. Care should be used in the drilling of the aluminum panel as drills very readily "creep" and turn over at the edges of the hole. It is necessary that a very sharp drill is used. It would be well to wire the bridge with No. 12 solid bus wire, as this is very rigid, which is quite necessary.

The two 1 megohm grid leaks should be as close as possible in value but it is not essential that they be closer than 10 per cent of each other. After the bridge has been constructed and wired it is then ready for adjustment. The type 213 oscillator should be connected to the bridge as illustrated and turned on. The variable standard condenser should be turned to maximum capacity and the dial set at zero. This is very important and should be done with care. Upon connecting the phones it will very probably be found that the thousand cycle signal is very loud. The semi-fixed condenser should then be rotated preferably with some insulated material such as a bakelite rod or wood sticks until as good a null point as possible is reached. The zero adjustment condenser should be set at approximately 50 degrees of the dial or one-half capacity. Then rotate the loss adjustment condenser and it probably will be found that a perfect null point is reached. The bridge is then balanced and the .0005 mfd semi-fixed condenser should be left in this position and not moved. If a condenser is then placed across the unknown capacity binding post, the bridge will be out of balance until the variable condenser is turned which decreases its capacity to a like amount as the unknown condenser. Therefore, if the amount of decreased capacity is known, the capacity of the unknown condenser will be known. Inasmuch as the condenser used is a straight line capacity, it will have a certain amount of capacity for every division on the dial. This capacity will probably be equal over 90 per cent of the dial reading, that is, from zero to 90, the reading of the dial. Therefore, if the capacity factor per division of the dial is 2.4 mmf and we find that the dial reading is 10, after the bridge has been balanced and the unknown condenser connected, we will multiply the dial reading 10 by 2.4 which would be 24 mmf. As it is probable that there are no two condensers that have identically the same capacity,

it would be well after constructing and testing the bridge to have it calibrated to obtain the correct factor of capacity per degree of dial reading.

How to Measure

Now consider that we are going to measure a condenser from the start. Turn the capacity dial to exactly zero. Then turn the zero adjustment condenser and the loss adjustment condenser simultaneously until the perfect null point has been reached. After this has been set do not change the zero adjustment condenser while making measurements as this will destroy the value of the capacity dial reading. The unknown condenser is then placed across the X binding post with as short a lead as possible. The capacity dial is then rotated until the null point is reached. It may be found necessary to change the loss adjustment condenser to compensate for the change in losses between the standard capacity condenser and the condenser under measurement, but do not under any other condition change the zero adjustment condenser. When the null point is reached note the reading on the capacity dial and multiply it by the capacity factor in the bridge and you will have the capacity of the unknown condenser. To increase the range of the bridge over .00025 mfd it is necessary to add to one side of the bridge a standard condenser. In this particular instance we have added four condensers having the values of .00025, .0005, .001 and .01 mfd. Sangamo mica condensers were selected and have the advantage of having threaded bushings for connections. In this may be screwed General Radio plugs which fit into the range standard jack very conveniently with a minimum amount of increased capacity. These four range standards should be calibrated to six or eight places to determine their absolute capacity in order to obtain accurate results. In order to use these condensers to measure values above .00025 mfd the following steps are taken: First, the bridge should be balanced at zero setting of the capacity dial. Then insert the standard condenser and connect the unknown condenser. The bridge should then be balanced as in the previous case. The value of the unknown capacity is merely the dial reading of the capacity dial times the capacity factor of the bridge plus the capacity of the standard condenser.

It will be readily seen that all types of variable condensers may be calibrated for capacity or three or four gang condensers may be lined up for capacity and measured up for accuracy of stages, fixed and midget variable condensers may be very readily, simply and quickly calibrated.

Parts Required

The following parts are required for the construction of the capacity bridge here described:

- 1—8 x 19 x 3/16-inch aluminum panel
- 1—Thordarson R-300 transformer
- 1—Thordarson R-200 transformer
- 1—National .0005 mfd SLC condenser
- 1—National .00025 mfd SLC condenser
- 2—Hammarlund 65 mmf condensers
- 1—Hammarlund 15 mmf condensers
- 2—Amsco 2 megohm grid leaks

- 2—Amsco mountings
- 7—Eby binding posts
- 3—Bakelite strips
- 8—General Radio 274-P plugs
- 2—General Radio 274-J jacks
- 1—General Radio 303 vernier dial
- 1—General Radio 310 dial
- 1—General Radio 213 audio oscillator
- 1—Sangamo .00025 mfd mica condenser
- 1—Sangamo .0005 mfd mica condenser
- 1—Sangamo .001 mfd mica condenser
- 1—Sangamo .01 mfd mica condenser

A Production Breakdown Test For Leaky Condensers

By R. O. LEWIS

Engineering Dept., Grigsby-Crunow Co.

THE ideal breakdown test should indicate the condenser which breaks down, without rupturing or blackening the material around the puncture. This is true, because it is necessary to examine the puncture in the laboratory to determine the cause of breakdown. Also, the apparatus used for breakdown test must not furnish enough energy, or current through the puncture, to melt the foil back from the puncture, causing the condenser to heal itself temporarily. A condenser self healed is almost certain to break down later in someone's power unit. This comes about by the formation of carbon and water, from the wax and paper, when the heat due to the heavy current breaks down these materials chemically. The carbon is already a conductor, also the water in combination with the materials of which the paper is composed makes an excellent electrolyte through which current will readily pass.

When the lamp is once lighted or flashed the voltage can be reduced more than twenty volts below the flash voltage, with the glow still apparent, but much less pronounced. After the lamp is flashed and the voltage is then reduced the glow persists growing more faint, as the current through the lamp decreases, until at about 100 to 200

microamperes it becomes invisible and the current drops to zero.

It is best to select the lamp for use from several, as some lamps cease to glow at higher current values and are therefore less sensitive as leak indicators, but can be used as short indicators on a life test.

Curve of Neon Lamp

A characteristic curve of a neon lamp used for test purposes is shown in Figure 6. The flash voltage at which this particular lamp lights is 146 volts. The curve shows that the voltage can be reduced to 118.5 volts before the current is reduced to zero. The glow disappears when the voltage has reached 119 volts. The current at which the glow disappears is less than 100 microamperes.

The resistance values of the lamp for calculation can be taken directly from the curve as the voltage divided by the current at any particular point on the curve gives the resistance. Thus at 120 volts the current is 200 microamperes

(Continued on page 126)

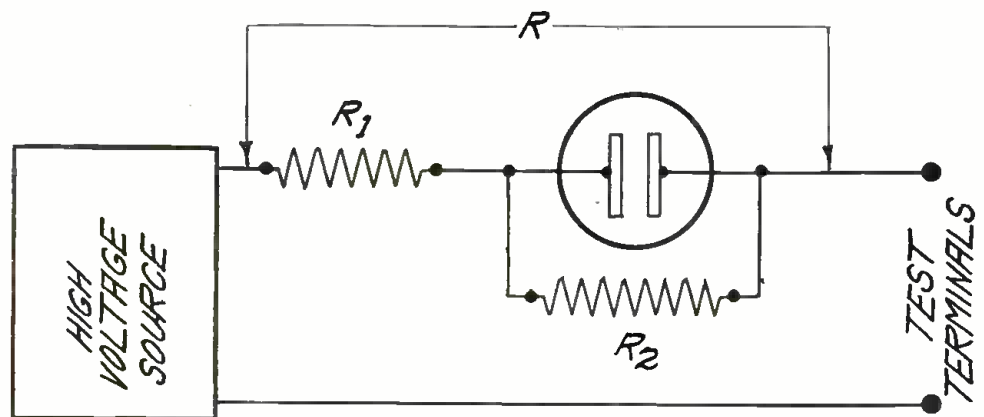

Figure 7

Rugged Test Set

A rugged test set, which will do the above mentioned things and in addition detect a condenser which does not blow but shows a leakage current of less than 200 microamperes, can be constructed at low cost.

The apparatus consists of the usual high voltage source, a pair of resistors and a small one hundred volt neon lamp. The arrangement is shown in Figure 7.

R_1 is the current limiting resistor, it limits the current to a low value which does not overload the neon lamp or burn the condenser. R_2 is the voltage resistor. When the current flows through R_2 a voltage is built up across the lamp causing it to light.

The neon lamp has a characteristic as follows: When a d. c. voltage across the lamp is steadily increased from zero, there is no apparent current flowing, until a certain definite voltage is reached. Then, the lamp flashes or a glow appears on one of the electrodes.

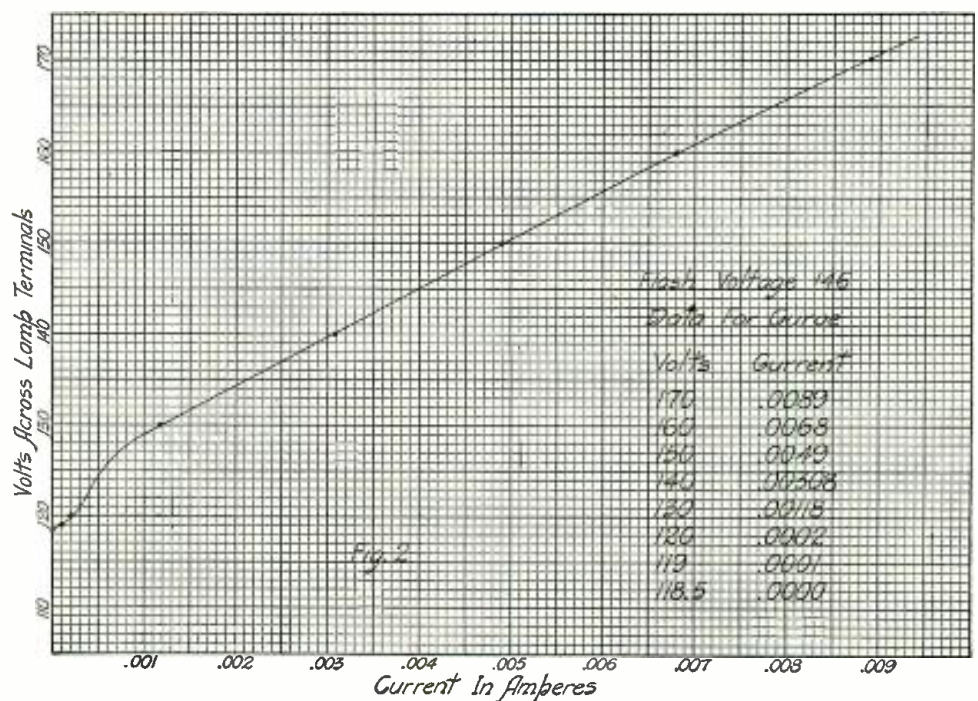
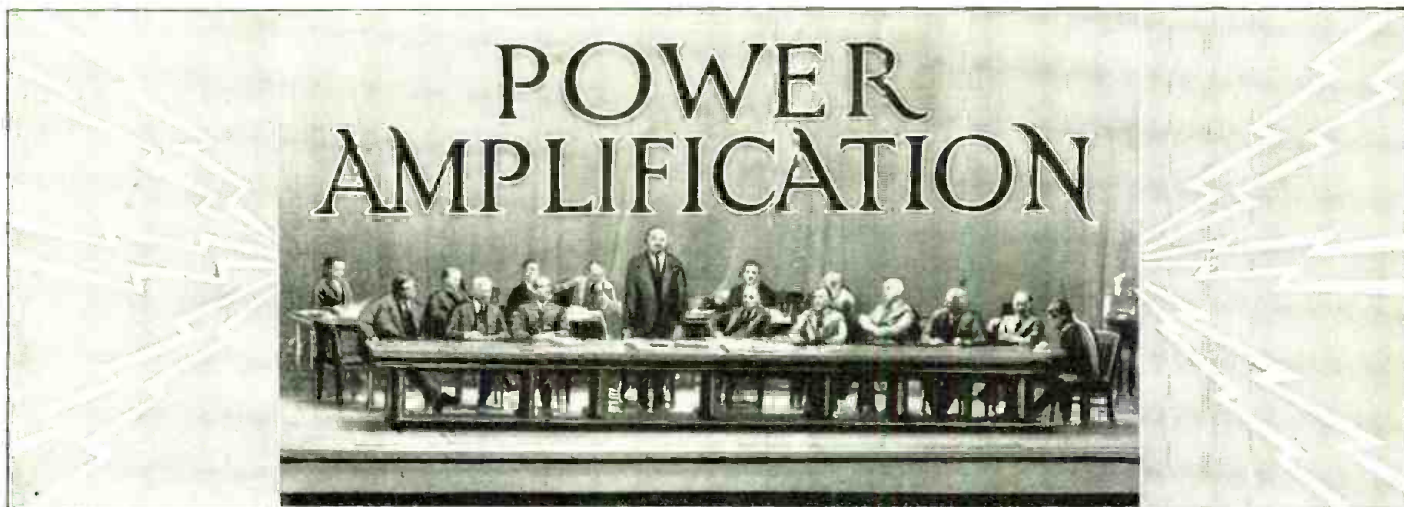

Figure 6



Amplifier for Belasco Play

DAVID BELASCO in his production of "Mima" used an amplifier to produce the various stage sounds he needed and also for the amplification of the orchestral music.

The amplifier was constructed in such a manner as to make it suitable for all purposes for which an amplifier could be used. It was designed so that it could be transported and set up in a theater in a short space of time.

The setting for the play represented a gigantic machine which extended out into the auditorium.

Where to Put Orchestra?

The pit that is generally used for the musicians was made a part of the scene and a great deal of the action took place there. As a large orchestra was needed for the many music cues a new

Fig. 1. This photograph shows the elaborate mechanical set-up required for the Belasco play described in this section

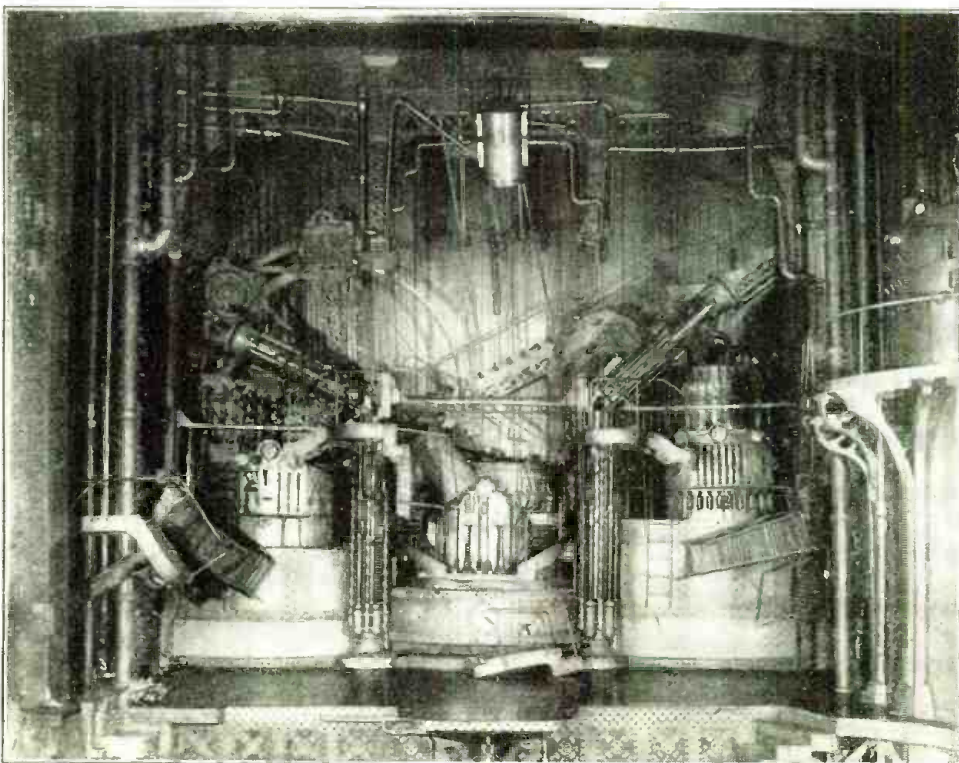
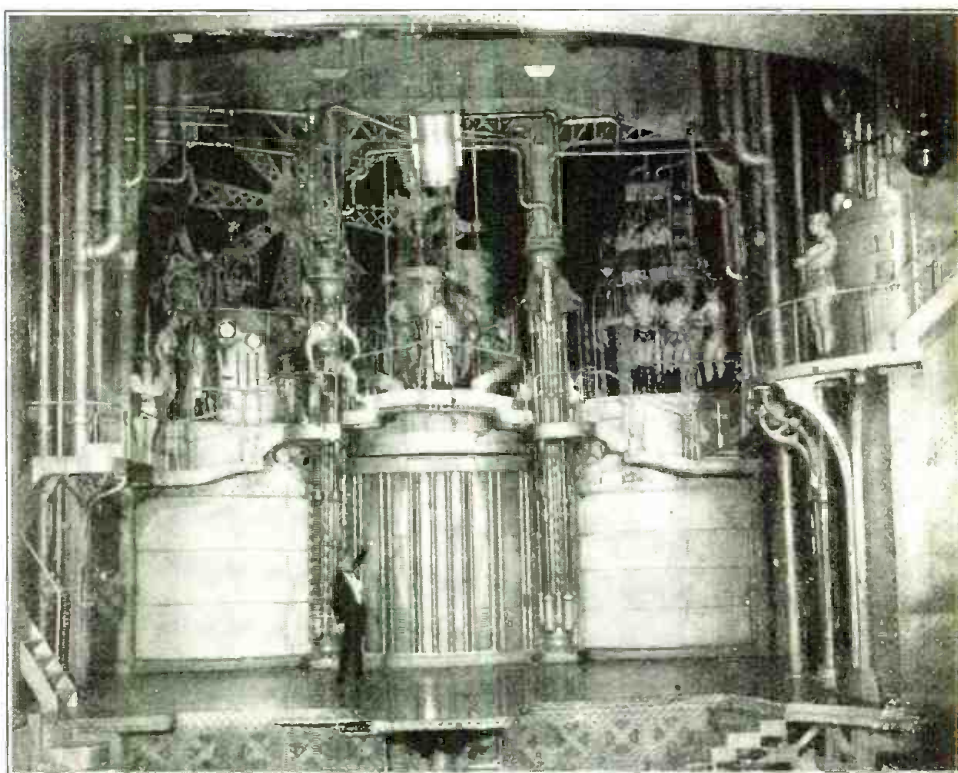

place had to be found for the musicians.

The stage was overcrowded with scenery, so that the only available space where the musicians could be placed was in the fly-gallery.

The large setting was enclosed with a cyclorama which extended from the stage to the grid-iron, which being made of heavy oil cloth kept the sound of the music from reaching the auditorium. But amplification solved the problem. Two three button microphones were placed in the fly-gallery which were connected to the input panel of the amplifier.

The input panel consisted of two AmerTran mixers, a Thordorson microphone transformer and three stages of impedance coupled amplification, using Thordarson Autoformers.

The input panel was coupled to an

Fig. 2. A thrilling moment in the play "Mima" when the machinery was wrecked

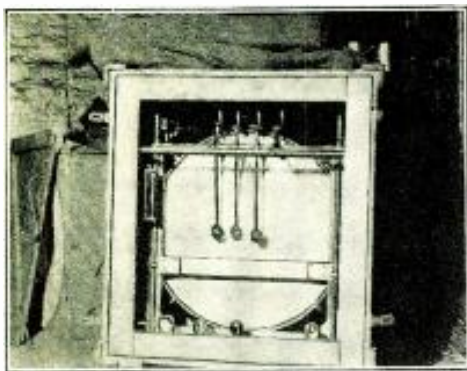

Fig. 3. This is one of the drums used in producing sound effects to simulate noises of heavy machinery in full operation

amplifier using one stage of straight audio and one stage of push-pull.

The first stage using a 112-A tube the push-pull stage using 4-250 tubes in parallel. In the first stage a Thordarson R-300 transformer was used, the push-pull transformers were also Thordarson.

Locating the Speakers

The output of this panel was fed to three giant dynamic units made by the Amplion Co. which were attached to three exponential horns, these were made by the Racon Co.

One of the speakers was hung in the center of the stage over the proscenium arch, with the opening facing the back of the stage, the others were placed in the first entrance back of the proscenium and almost against the side walls. The openings were faced slightly back stage and not directly at the audience. It was found through experiment that better quality was obtained when the speakers were not directed toward the auditorium. The speaker on the right was under the fly-gallery on which the musicians were playing and where the microphones were placed, but curiously there was no howl created in the speaker, a thing that generally happens when the microphones are placed in such close proximity to the speaker. This proves that it is best not to depend too much upon theory. Small changes in conditions may reverse the entire order of things.

For the sound effects various devices were used and these were actuated by motors.

The device that created the sound, a motor and a two button Amplion microphone was placed inside of a box. The microphone was connected to an input, the arrangement being identical to the one that was used for the music.

The modulator was set for maximum amplification and the volume was controlled by 2-400 ohm resistances on the mixer. the panel having two mixers one effect could be brought on after the other and any degree of sound could be

obtained from barely audible to maximum.

Making the Noises

The sound effects in this instance were used to create noises that would be produced by heavy machinery in full operation. Mechanical bass drums in boxes produced the deep tones. On one of the drums a piece of tin was interposed between the beaters and the head and this was fastened only at the lower edge, the tin being loose gave a metallic vibration.

A whirring sound was produced by a snare drum. A motor had a wooden disk attached to its shaft on which were fastened two straps and the centrifugal force created by the speed of the motor threw these straps outward and as they struck the drum head in a succession of rapid beats they produced a continuous whirring sound.

Another effect was composed of a small motor on the shaft of which was fastened a thin metal disk, the edge of the disk having a series of perforations, the protruding edges of which struck a piece of thin brass held in a clamp and which was adjustable, so that the pres-

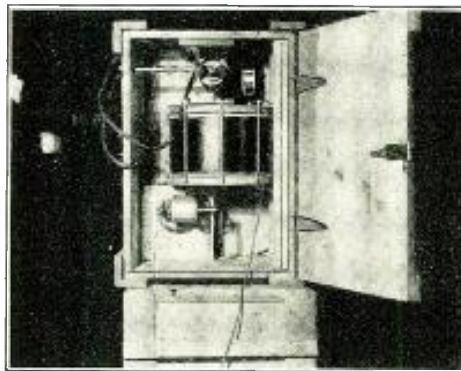

Fig. 4. Another one of the drums which produced a whirring sound in the play "Mima"

sure could be varied against the perforations. By regulating the pressure the sound was varied and could be reduced from a high metallic whirr to a low metallic beat.

Power Supply Portable

The power supply for the amplifier consisted of two Esco generators, made by the Electric Specialty Co. of Stamford, Conn. The one which supplied the current for the filaments was a dynamometer having an output of 17 amps. at ten volts.

The B supply was a motor generator, the generator having a split winding, and gave voltages of 135 and 500.

Both sets had a field rheostat for voltage regulation. The generators were installed in separate metal lined boxes with hinged covers. When the covers were closed the boxes were ready for transportation.

The filters and chokes for the A and

B were installed on the two lower shelves of the cabinet.

The current for the microphones was supplied from a six volt storage battery. The 10 volt generator supplied the current for the fields of the dynamic speakers and a resistance was used to cut this to 7 volts. One of the panels was used as an amplifier for records. Two Stromberg Carlson pick-ups were used on two electric turntables.

Each panel was built on a shelf that could be drawn out of the cabinet for examination or repairs.

On the input panels there were 4 milliammeters which were used for the readings of the microphone current and to keep a check on the microphones. These are a necessity as the microphones would get packed. Each panel was provided with jacks so that a milliammeter could be inserted at any stage for testing the circuit or to check up on the condition of the tubes.

What Play's About

During the theater season of 1929, all of New York talked about the extraordinary production that was produced by David Belasco at a tremendous expense. The name of this play was "MIMA" and was taken from the story called the "RED MILL." The name "RED MILL" gives one a better idea of what the play consisted of than the name "MIMA," due to the fact that the whole stage setting was one stupendous machine. The entire stage was torn up and rebuilt in order to facilitate the many details necessary for the complete construction of this big machine.

Over 100 electric motors were used to drive the moving mechanisms, all of which were built of the genuine parts such as worm gears, reciprocating shafts, huge flywheels and mammoth cylinders. The appearance of the setting was very impressive.

Devil Designs Machine

The story reads that this machine was designed by the devil and it took him about a million years to complete its assembly. So large was its construction

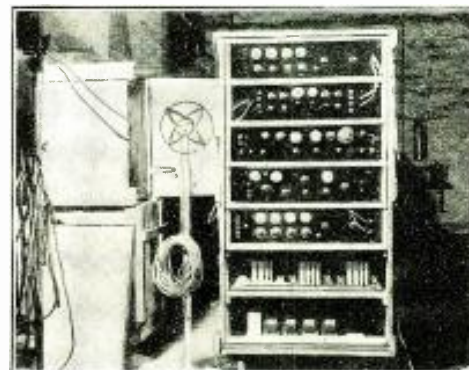

Fig. 5. The control panels each mounted on top of the other are shown in this photograph

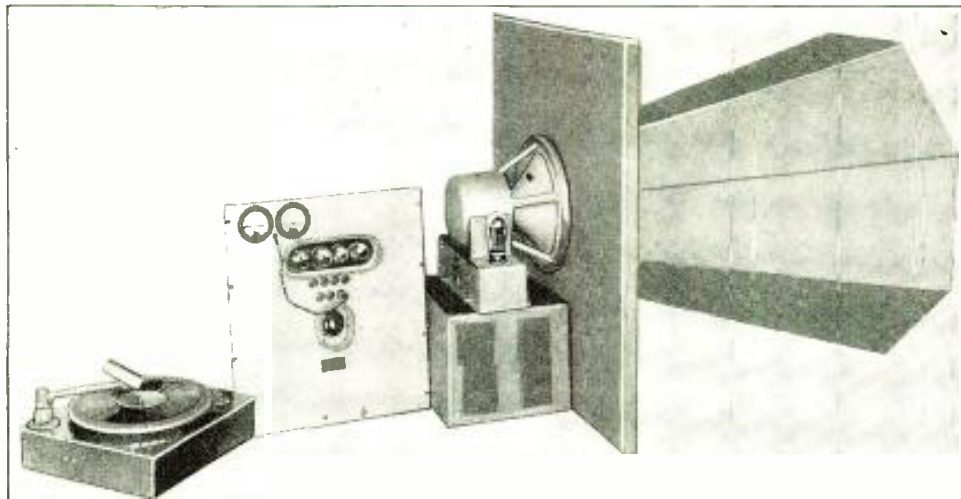

Fig. 6. The installation pictured above is one of the several which form a permanent exhibit in our laboratories. In this job the AmerTran public address amplifier is used with a Best speaker and Baffleboard Co. baffle

on the stage of the Belasco Theater that there was no room for the orchestra. Therefore, to supply music to the audience, the orchestra had to be located in a small room back of the stage. The next program was to carry the music from this orchestra out to the audience; also, to do justice to the massive appearance of this stage setting, proper sounds of great volume were necessary to duplicate the sound of a huge machine in motion. This problem was solved through the combined efforts of Mr. Hartman, who is the head of Belasco's technical staff, and the acoustic engineers of the Amplion Corporation of America.

Makes Own Installation

ONE of our readers, Edward M. Scribner of Schoharie, N. Y., sent us photographs and a description of a public address system that is used in his home town theater. On account of the number of requests for material of this sort we are quoting his letter in full:

Built in 2 Decks

"I am enclosing several photos of our theater music outfit which we (Minard Spateholtes and myself) made according to your article in the Janu-



Fig. 7. Firemen's Hall, Schoharie, N. Y., where the device is in use. Outfit in room with window to right of entrance on front shown on right of picture. Hall 100 feet long and 40 feet wide

ary issue of your Call Book. In order to reserve all the room possible and to make the unit more compact we made it a 'double decker' having on the bottom shelf the power and filament supply unit together with plate resistors and all condensers. Extra condensers were placed in the bank to make changeover to a new one should one break down very easy. The condensers

Watch For It

In the January issue of the CITIZENS RADIO CALL BOOK MAGAZINE will appear a description of the installation of the Natural Sound Amplifying System for distributing music and speech from one park to twenty-five other parks in the City of New York. This contract was awarded to the Natural Sound Amplifying System, Inc., of Philadelphia and New York.

The points of origin are located in Central Park, Manhattan, and Prospect Park, Brooklyn, from where the sound is distributed to twenty-five other parks in the five boroughs of the City of New York through fire department wire headquarters in each of the five boroughs over approximately six hundred miles of the fire department cable system.

—Editor.

were not in a block as you described them but were made up of single units. A metal strap holds them in place as well as grounds all the metal containers which are soldered to the supporting strap. The top unit or shelf contains the amplifier, transformers, grid resistances, center tap resistances and the various jacks (one inserted in the plate circuit of each tube including the rectifier tubes to measure plate current instantaneously without the use of a test set, etc.) and switches.

"Now one 150 m. a. milliammeter

and one 10 m. a. milliammeter will make all of the plate current readings of the set by simply plugging in on the desired jack. The jacks and meters are so situated so as to make it impossible to plug the 10 meter into the 250 or 281 plate circuits. This is done by making the length of the cord on the plugs going to the meters of certain lengths. On the left of the panel (also not shown) is a switch for cutting in records, microphone or radio at will without changing connections with wires, etc. On the right of the set there is another switch (not shown) which gives any desired selection of output impedances from the S-M 248 transformer.

Be Careful of Hum

"Now to tell you what was used and the plan of the layout. All the transformers used were Silver-Marshall. The choke coil was also Silver-Marshall. In mounting the first two transformers care must be exercised or an abnormal amount of hum will be experienced. The first transformer S-M 255 is mounted on end as is the second S-M 257 and the mounting is so made as to make them movable. This aids greatly in doing away with considerable hum. And by all means ground the device before the set is turned on to determine the position of the various parts.

"The volume control for the amplifier is a 100,000 ohm potentiometer. We tried several places to use this but the most satisfactory was by hooking one end of the resistance strip to post No. 3 of the first transformer, the other end of the resistance being grounded and connecting the movable arm to the grid of the 227 tube. We also discovered that a center tap on the 281's rid the apparatus of some hum.

Two Turntables Used

"Now to the turntables. Two turntables were used. Each electrically driven by induction motors. Each turntable was 12 in. in diameter. The electric pick-ups are Pacent DeLuxe. Several were tried but Pacent seemed to give the best results. Our fading devices and volume controls are very stable and simple in operation giving the best results from all types that we tried.

"The speakers used are as follows:



Fig. 8. Complete set up of amplifier and turntables

One Peerless 7 in. cone and one remodeled Magnavox horn type made over into a cone. Both are dynamics. Hum from speakers inaudible 10 feet away. Photo shows Peerless 7 in. cone mounted on 1 in. wood casing. The front is plaster board. The speaker is mounted on a shelf and set snug against the front of the case but not bolted fast by any means. The speakers set at the angle to the screen shown.

"The turntables and amplifier are enclosed in a little room off the main auditorium at the back. As you will notice from the picture of the interior of the theater the floor is flat using chairs for seats. This affords the possibilities of dancing and suppers. The room is so located that the volume can be readily adjusted to bring out certain records soft or loud as desired. The booth is directly above and a telephone system makes communication very easy. The interior of the theater being very high (36 feet) and the side walls with no hangings makes reproduction or orches-

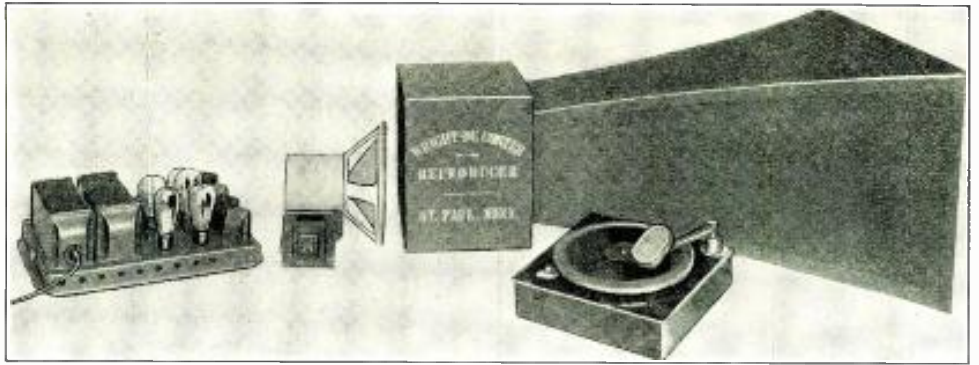

Fig. 9. In this photograph is shown the Samson PAM amplifier and the Wright-DeCoster dynamic speaker and flare. This is another of the units in the permanent demonstration in our laboratory

Free Street Movies

"The season at the Firemen's Hall is now over as we have during the summer months free street movies. It was at first planned to use this for music for them as heretofore no music whatever accompanies the picture. The Board of Trade were very enthusiastic about it at first and wanted it but they thought that it could be rented and operated for them for about \$7.50 a night including music, etc. Well, I gave them a different idea of it. Danger of damage in transporting and the tubes blowing out made it utterly impossible to do it for that amount and then there is the music to consider also. The plan was to have them buy whatever extra records were necessary and these in turn become our property for the use of the rest of the records.

"It seems that it will not go on the street. We might, however, put it on one night for our own curiosity to see just how it will work. Then the Board of Trade will look more friendly to it and perhaps we will get the job. It will

be of great value to us to try it so that we may further the development of it in whatever ways we can.

"Recently I have placed a new fader control for changing over records. This consists of a center tapped potentiometer. I bought a 250,000 ohm resistor and soldered a center tap on it. This by the way was a graphite resistor with the small U shaped wired on it to take the brunt of the wear from the sliding arm of the potentiometer. It, of course, is used also as a volume control for the individual record but as I told you before the main volume control is located in the grid circuit of the 227.

"We are now attempting to make an adapter to use it with a Majestic radio set for stepping out the volume and preserving the tone quality. The results of this will be sent you as soon as the tests are made.

"I have your summer edition of the Call Book and find the article concerning the Silver-Marshall 720 using Uy-224 tubes just what I want. I have considerable of the parts especially the condensers. The small fixed condensers $\frac{1}{4}$ mf that I have are considerably larger than those shown in your cuts of the set."

P. A. and Speaker Exhibit

SO much interest has been created in power amplification work, especially as it refers to theatre, dance hall and other entertainment installations that we have put together a permanent demonstration exhibit in our laboratories at 508 South Dearborn Street, Chicago, Illinois. Two of the participants in the permanent demonstration are shown in Figures 6 and 9 in this section. The first one is the AmerTran public address amplifier in connection with a Best speaker and a Baffleboard Co. baffle; the second installation is one employing a Samson PAM amplifier and Wright-DeCoster dynamic speaker and flare.

Those contemplating installations of this type will have an opportunity of calling at our laboratories where these installations may be inspected.

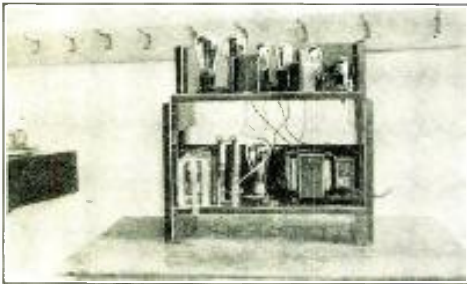

Fig. 10. This is the power amplifier. In the top deck are located the main tubes and transformers, grid bias and meters. From left to right: first two 250's, then two 226's followed by a 227. Lower shelf contains plate and filament voltages, plate resistances, condensers and filter system

tra and stage acts quite difficult but with our outfit we have not had the least trouble with acoustics. It simply is grand and spell it with a capital G. Only Victor electric cut records are used.

"To give you an idea of just how faithful the reproduction is Mayor P. E. Taylor of Schoharie says that it is the best he has ever heard including Vitaphone, Phototone, Movietone and Photophone. Mr. Taylor is a very ardent movie fan and knows what he is talking about. Matt Merenese, a veteran in moving pictures, having written several movie plays himself, says that it is the most natural of all musical reproducing devices including the above, as did Mr. Taylor, that he has ever heard. He praises it for its fullness of tone quality and freedom from needle scratch. John Fain, fire chief, says equally as well of it as do the rest. Very few people attending the movies know how it is done and most think it is like the talkies.

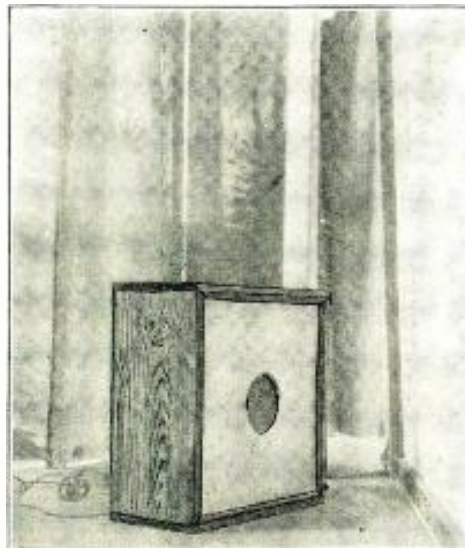

Fig. 11. This shows the Peerless 7 in. dynamic speaker on the stage. The box is 1 in. wood, 12 in. wide and 2 ft. square. There is no back to it. The front is plaster board and the speaker sets snug against it. There are two such speakers, one at either end of screen



Radio Test Table

At the recent radio shows in New York and Chicago the Weston Electrical Instrument Corp. of Newark, N. J., had on demonstration a radio test table, a photograph of which is given on this page, Figure 1. The schematic wiring diagram involved in the radio test table is shown in Figure 2 on the next page.

For the benefit of those who might have a desire to build up such a test table in their work shop or service department, we are giving herewith the list of material required for the construction of such a table. The first portion of the list of parts comprises those units which are available from Weston, while the remainder of the parts lists shows the material which is to be obtained from other sources.

List of Parts

- 1—Model 301 milliammeter, 1.5 m. a.
- 2—Model 301 voltmeters, 15 v. (1000 ohms per volt.)
- 1—Model 301 milliammeter, 15 m. a.
- 1—Model 476 voltmeter, 750/150/16/8/4 volts.
- 1—Model 301 voltmeter, 100 volts, (1000 ohms per volt.)
- 1—Model 301 voltmeter, 8 volts, (1000 ohms per volt.)
- 1—Model 476 condenser meter, 1.5/15 mfd.
- 1—Model 301 voltmeter. 750/250 volts, (1000 ohms per volt.)

All the above instruments are provided with Bakelite cases.

- 1—150 m. a. shunt for 1.5 m. a. milliammeter.
- 2—135,000 ohm multipliers to increase 15 volt range to 150 volts.
- 1—150 m. a. shunt for 15 m. a. milliammeter.
- 2—20,000 ohm multipliers for 750 volt a. c. range.
- 1—80 ohm multiplier for 16 volt a. c. range.
- 1—40 ohm multiplier for 8 volt a. c. range.

- 1—500,000 ohm multiplier for 750 volt d. c. range.
- 1—Cord, plug and adapter.
- 1—Filament selector switch and dial.
- 2—Single pole, double throw push buttons.
- 1—Single pole, single throw (closed) push button.
- 1—Bakelite panel, 28 x 14 x 3/16 inches, engraved.
- 4—Yaxley double pole, double throw switches.
- 1—Yaxley single pole, double throw switch.
- 1—Yaxley single pole, single throw switch.
- 2—A. C. outlets.
- 2—Switches for outlets.
- 19—Eby binding posts.
- 1—Eby UX type socket.
- 1—Eby UY type socket.
- Misc. nuts, screws, bolts, etc.

Western Electric Tubes

With the increase in public address work being performed and the amount of service which such systems require, we have had many requests from readers for the characteristics of tubes made by the Western Electric Co.

Very few of the Western Electric tubes are available to the general public because these tubes are furnished either to radiophone broadcasting stations operating under A. T. & T. or in connection with power amplifiers or public address systems built by the Western Electric Co. However, there is an exception in the case of the 205 and the 216 type tubes, which are not restricted. Accordingly we are giving in the table below the characteristics of the two tubes not restricted by the Western Electric Co. Perhaps this information will be useful to many of those who have written for this data.

No. 205-D Vacuum Tube:

- Normal filament current, 1.60 amperes
- Normal filament voltage, 4 to 5
- Normal plate voltage as amplifier, 200 to 300
- Normal plate voltage as oscillator, 350
- Normal grid voltage as amplifier, —10 to —20
- Normal plate current, 15 to 30 milliamperes
- Plate to filament impedance, 3000 to 4500 ohms
- Maximum safe plate voltage, 350
- Amplification constant, 6 to 7.5

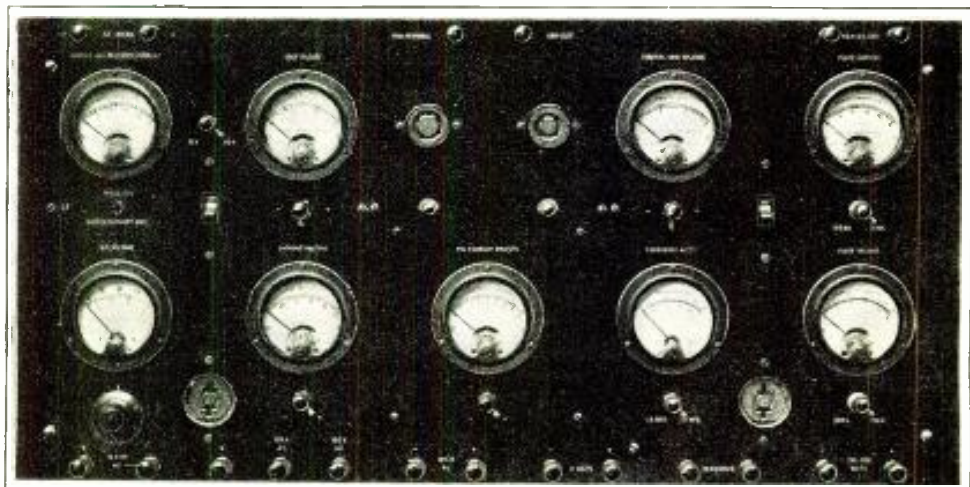

Figure 1

Marvin Tube Characteristics

Type Number	Filament Terminal Voltage	Filament Current (Amperes)	Detector Bias (Megohms)	Detector "B" Voltage	Detector Plate Current (M. A.)	Amplifier "B" Voltage	Amplifier "C" Voltage	Amplifier "C" Bias Resistor (Ohms)	Screen Grid "B" Voltage	Screen Grid Current (M. A.)	Plate Resistor (Ohms)	Amplifier Plate Current (M. A.)	A. C. Plate Resistance (Ohms)	Mutual Conductance (Micromhos)	Voltage Amplification Factor	Maximum Undistorted Output (Milliwatts)	Purpose
MX-199	3.3	.06	---	45	---	90	4.5	1,910	---	---	---	2.35	15,600	425	6.6	---	Det. & Amp.
MX-201-A	5.0	.25	---	45	---	90	4.5	1,910	---	---	---	2.35	11,300	725	8.2	---	Det. & Amp.
MX-222	3.3	.132	---	---	---	135	1.5	750	45	2	---	1.5	850,000	350	300	---	Amplifier
MX-226	1.5	1.05	---	---	---	135	9.0	1,730	---	---	---	5.2	7,800	1,050	8.2	---	Amplifier
MY-227	2.5	1.75	---	90	---	180	13.5	2,250	---	---	---	6.0	8,800	1,000	8.8	---	Det. & Amp.
MY-224	2.5	1.75	---	---	---	180	1.5	283	75	1.8	---	4.0	400,000	1,050	420	---	R. F. Amp.
MX-120	3.3	.132	---	---	---	135	22.5	3,360	---	---	---	6.7	6,300	525	3.3	110	Power
MX-112	5.0	.50	---	---	---	135	9.0	1,285	---	---	---	7.0	5,000	1,640	8.2	300	Power
MX-171	5.0	.50	---	---	---	180	40.5	2,025	---	---	---	20.0	2,000	1,500	3.0	700	Power
MX-245	2.5	1.5	---	---	---	250	50.0	1,515	---	---	---	33.0	1,900	1,850	3.5	1,800	Power
MX-250	7.5	1.25	---	---	---	450	80.0	1,455	---	---	---	55.0	1,800	2,100	3.8	5,000	Power

NOTE:—Divide C bias resistor value in ohms by number of tubes paralleled (or push pulled) to get proper C bias resistance.

Maximum continuous plate watts, 15
 Maximum intermittent plate watts, 20
 Watts output as an oscillator, 5

No. 216-A Vacuum Tube:

Normal filament current, 1.0 amperes
 Normal filament voltage, 5 to 6 volts
 Normal plate voltage, 130 volts
 Maximum safe plate voltage, 160 volts
 Maximum plate current, 6.5 milliamperes
 Grid voltage, —9 volts
 Plate filament impedance, 5900 ohms
 Amplification constant, 5.9

Constant Resistance Control

THERE have been objections in the past to the usual type of volume control when used on a phonograph pick-up or on an amplifier, the principal objection being that in the variation of the volume the impedance of either the input or output circuit is changed.

However, we now note that a new type of constant resistance volume control known as the Tonatrol type U is being marketed by Electrad, Inc., of New York.

This particular constant resistance volume control has been designed primarily to control the volume of the phonograph pick-up. The basic difference between this volume control and the ordinary rheostat or potentiometer type of control is that varying the volume does not effect the impedance of either the input or output circuit. A smooth and noiseless volume control therefore results.

Type U Tonatrol has three terminals. The two bottom terminals of the Tonatrol connect to the phonograph pick-up terminals while one of the bottom terminals and the top terminal connect either directly to the grid and filament terminal of the detector tube or to the input terminals of a pick-up transformer.

This constant resistance volume control may also be used to control the volume of individual speakers connected to the same amplifier providing the power supplied to each speaker does not exceed two watts. Individual speaker volume may be varied without effecting the sound amplitude of the speakers connected in the same circuit. In this case the terminals at the bottom connect to the amplifier output terminals while the speaker terminals connect to one of the bottom terminals and the top terminal.

Potter Replacements

FOR the benefit of those having service calls on Majestic, Brown or similar B eliminators, we are giving herewith the code numbers of Potter condensers which may be substituted without any alteration in the wiring. On the Majestic Master B eliminator which is a 60 mil 150 volt job Potter condenser code 4359 should be used;

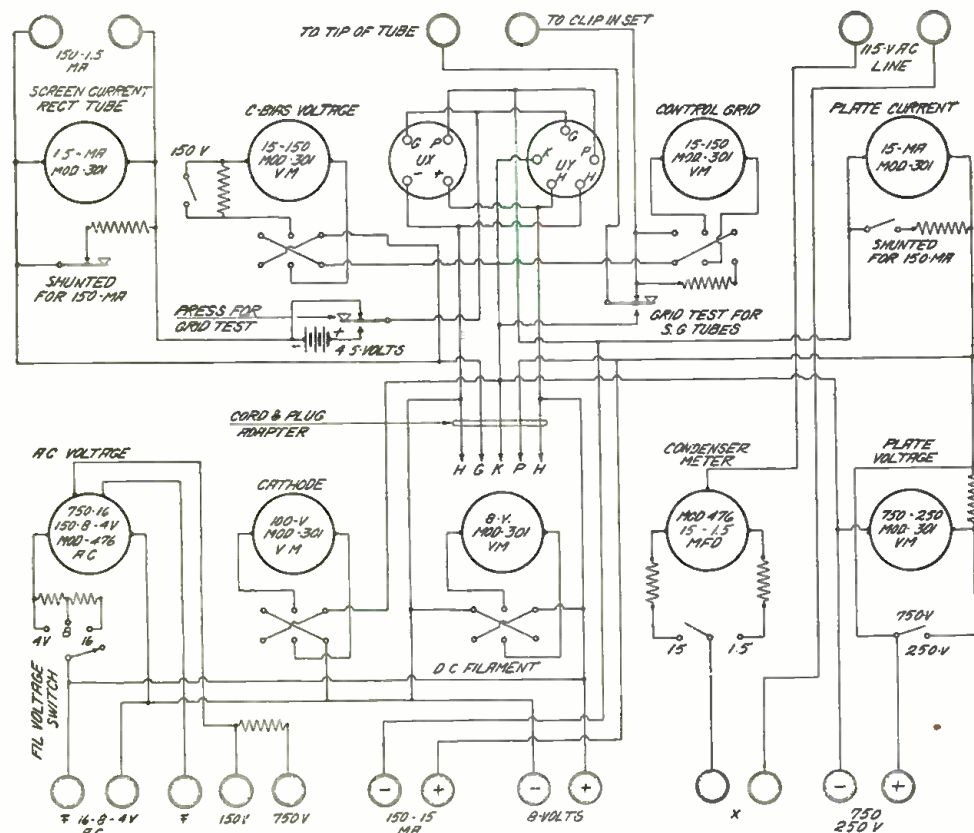

Figure 2

on the Brown B Super Power one to twelve tube capacity Potter code 4360 should be employed. In the case of the Majestic Super B eliminator Potter condenser 4347 is substituted. Potter condenser 4343 may be used in the Majestic Special Master B eliminator which is a 60 mil at 180 volts job. In the case of the Majestic Standard B eliminator Potter condenser type is 4341.

Sell Sets to Police

NEW YORK'S blue coats are to have 200 cruising cars equipped with receiving sets to intercept department orders flashed from a new short-wave transmitter installed in police headquarters. Each set, placed in one of the speedy runabouts of the department, will be constantly tuned to station WPY at headquarters. A gong will sound in the receiving set, so that patrolmen may listen-in for orders. The

dispatches will be by radio telephone—since it would otherwise be necessary to train at least 200 patrolmen as operators.

Other cities are already making use of radio keeping in touch with patrolmen. In some cities the usual broadcasting stations are employed for flashing police reports. While at first thought this would seem poor practice, inasmuch as criminals may be notified of police movements, as a matter of fact there is very little lost since criminals can tune in short-wave signals quite as well as broadcast signals if they wish to do so. Meanwhile, broadcasting the police bulletins serves to inform the public at large, who in many instances are thus in position to help the police, particularly in such matters as missing cars, suspicious characters, missing persons and so on.

Perhaps receivers for picking up big city police broadcasts can be sold to police departments in smaller cities.

Recommended Connections

OUR editorial department has recently received a technical pamphlet prepared by the engineering department of Electrad, Inc. It covers several recommended methods for controlling volume in radio receivers and phonograph pick-ups. A description is given of the super Tona-trol which should be of interest to our readers. Those desiring a copy of this pamphlet may secure it upon application to Electrad, Inc., 173 Varick Street, New York City.

Pigtail Resistors Simplify Wiring

THE advent of the socket-power radio set has brought about a demand for various resistance values to be inserted in the circuit for such functions as grid-biasing, grid-suppressing, voltage dividing, voltage drop and

Sonatron Tube Characteristics

Type Number	Filament Terminal Voltage	Filament Current (Amperes)	Detector Bias (Megohms)	Detector "B" Voltage	Detector Plate Current (M. A.)	Amplifier "B" Voltage	Amplifier "C" Voltage	Amplifier "C" Bias Resistor (Ohms)	Screen Grid "B" Voltage	Screen Grid Current (M. A.)	Plate Resistor (Ohms)	Amplifier Plate Current (M. A.)	A. C. Plate Resistance (Ohms)	Mutual Conductance (Micromhos)	Voltage Amplification Factor	Maximum Undistorted Output (Milliwatts)	Purpose																	
X 199	3	.06	2-9	45	1	90	4½	—	—	—	—	2.5	15,500	425	6.6	7	R.F. Det. A.F.																	
X 200A	5	.25	2-3	45	1.5	—	—	—	—	—	—	—	30,000	666	20	—	Det.																	
X 201A	5	.25	2-9	45	2	90	4½	—	—	—	—	2.5	11,000	725	8	15	R.F. Det. A.F.																	
X 226	1.5	1.05	—	—	—	90	6	1,714	—	—	—	3	10,000	800	8	55	A.F.																	
						135	9	1,500	—	—	—	3.5	9,400	875	8.2	20	R.F. A.F.																	
						180	13½	1,800	—	—	—	6	7,400	1,100	8.2	70	A.F.																	
Y 227	2.5	1.75	2-9	45	2	—	—	—	—	—	—	—	7.5	7,000	1,170	8.2	160	A.F.																
						¼-1	90	7	—	—	—	—	—	—	—	—	—	—	—	Det.														
						—	90	6	2,000	—	—	—	—	—	—	—	—	—	—	Det.														
						—	135	9	1,800	—	—	—	—	—	—	—	—	—	—	—	Det.													
X 240	5	.25	2-5	135	.3	135	1½	7,500	—	—	200,000	.2	150,000	200	30	—	—	Pwr. Detection																
																			2-5	180	.4	180	3	15,000	—	—	200,000	.2	150,000	200	30	—	—	Det. Res. A.F.
																			—	135	1½	—	—	—	—	—	—	—	—	—	—	—	—	R.F.
X 222	3.3	.132	—	—	—	180	+22½	—	—	—	—	.15	850,000	350	300	—	—	R.F.																
																			180	+22½	—	—	—	—	—	—	—	—	—	—	—	—	—	A.F.
Y 224	2.5	1.75	—	—	—	180	1½	375	+75	—	—	—	4	400,000	1,050	420	—	R.F.																
X 112A	5	.25	—	—	—	90	4½	818	—	—	—	—	5.5	5,300	1,500	8	120	Pwr. Detection																
						135	9	1,285	—	—	—	7	5,000	1,600	8	185	Pwr.																	
						157½	10½	1,105	—	—	—	9.5	4,700	1,700	8	275	Pwr.																	
						90	16½	1,650	—	—	—	10	2,500	1,200	3	130	Pwr.																	
X 171A	5	.25	—	—	—	135	27	1,625	—	—	—	16	2,200	1,360	3	330	Pwr.																	
						180	40½	2,025	—	—	—	20	2,000	1,500	3	700	Pwr.																	
						250	18	1,800	—	—	—	10	6,000	1,330	8	340	Pwr.																	
X 210	7.5	1.25	—	—	—	300	22½	1,737	—	—	—	13	5,600	1,450	8	600	Pwr.																	
						350	27	1,687	—	—	—	16	5,150	1,550	8	925	Pwr.																	
						400	31½	1,750	—	—	—	18	5,000	1,600	8	1,325	Pwr.																	
						425	35	1,944	—	—	—	18	5,000	1,600	8	1,540	Pwr.																	
						180	33	1,269	—	—	—	26	1,950	1,800	3.5	750	Pwr.																	
X 245	2.5	1.5	—	—	—	250	50	1,562	—	—	—	32	1,900	1,850	3.5	1,600	Pwr.																	
						300	54	1,542	—	—	—	28	2,100	1,800	3.8	900	Pwr.																	
X 250	7.5	1.25	—	—	—	350	63	1,400	—	—	—	45	1,900	2,000	3.8	2,350	Pwr.																	
						400	70	1,272	—	—	—	55	1,900	2,000	3.8	3,250	Pwr.																	
						450	84	1,527	—	—	—	55	1,800	2,100	3.8	4,650	Pwr.																	
						—	—	—	—	—	—	—	—	—	—	—	—	—	—	—	—													
						—	—	—	—	—	—	—	—	—	—	—	—	—	—	—	—	—												

NOTE:—Divide C bias resistor value in ohms by number of tubes paralleled (or push pulled) to get proper C bias resistance.

Cunningham Tube Characteristics

Type Number	Filament Terminal Voltage	Filament Current (Amperes)	Detector Bias (Megohms)	Detector "B" Voltage	Detector Plate Current (M. A.)	Amplifier "B" Voltage	Amplifier "C" Voltage	Amplifier "C" Bias Resistor (Ohms)	Screen Grid "B" Voltage	Screen Grid Current (M. A.)	Plate Resistor (Ohms)	Amplifier Plate Current (M. A.)	A. C. Plate Resistance (Ohms)	Mutual Conductance (Micromhos)	Voltage Amplification Factor	Maximum Undistorted Output (Milliwatts)	Purpose
CX-299	3.3	.063	2-5	22-45	1.5	45	1.5	1,500	---	---	---	1.0	19,500	320	6.6	---	Det. & Amp.
						67.5	3.0	1,765	---	---	---	1.7	16,500	380	6.6	---	Det. & Amp.
						90	4.5	1,800	---	---	---	2.5	15,000	425	6.6	7.0	Det. & Amp.
CX-300-A	5.0	.25	2-3	45	1.5	45	1.5	---	---	---	---	---	30,000	670	20.0	---	Detector
						45	1.5	---	---	---	---	0.9	18,500	430	8.0	---	Det. & Amp.
CX-301-A	5.0	.25	2-5	45	1.5	45	1.5	---	---	---	---	1.7	14,000	570	8.0	---	Det. & Amp.
						67.5	3.0	1,765	---	---	---	2.5	11,000	725	8.0	15.0	Det. & Amp.
						90	4.5	1,800	---	---	---	3.0	10,000	800	8.0	55.0	Det. & Amp.
CX-340	5.0	.25	2-5	135	.3	---	---	---	---	---	---	---	---	---	---	---	Amplifier
						180	.4	---	---	---	---	0.2	150,000	200	30.0	---	Amplifier
						180	3.0	---	---	---	---	0.2	150,000	200	30.0	---	Amplifier
CX-322	3.3	.132	---	---	---	135	1.5	9,100	45	.15	---	1.5	850,000	350	290	---	Amplifier
						180	1.5	2,380	22.5	6.0	250,000	0.3	150,000	400	290	---	Amplifier
CX-326	1.5	1.05	---	---	---	90	6.0	1,700	---	---	---	3.7	9,400	875	8.2	20	Amplifier
						135	9.0	1,500	---	---	---	6.0	7,400	1,100	8.2	70	Amplifier
						180	13.5	1,800	---	---	---	7.5	7,000	1,170	8.2	160	Amplifier
C-327	2.5	1.75	2-5	45	2.0	90	6.0	2,000	---	---	---	3.0	10,000	900	9.0	---	Det. & Amp.
						135	9.0	1,800	---	---	---	5.0	9,000	1,000	9.0	---	Det. & Amp.
						180	13.5	2,250	---	---	---	6.0	9,000	1,000	9.0	---	Det. & Amp.
C-324	2.5	1.75	---	---	---	180	1.5	---	75	---	---	4.0	400,000	1,050	420	---	Det. & Amp.
						90	16.5	5,160	---	---	---	3.2	7,700	428	3.3	---	Power
CX-220	3.3	.132	---	---	---	135	22.5	3,220	---	---	---	7.0	6,600	500	3.3	110	Power
						90	4.5	850	---	---	---	5.5	5,300	1,500	8.0	---	Power
						135	9.0	1,300	---	---	---	7.0	5,000	1,600	8.0	120	Power
CX-112-A	5	.25	---	---	---	157	10.5	1,050	---	---	---	9.5	4,700	1,700	8.0	185	Power
						180	13.5	1,350	---	---	---	9.5	4,700	1,700	8.0	275	Power
						90	19	1,900	---	---	---	10.0	2,500	1,200	3.0	130	Power
CX-371-A	5.0	.25	---	---	---	135	29.5	1,850	---	---	---	16.0	2,200	1,360	3.0	330	Power
						157	35.5	2,000	---	---	---	18.0	2,150	1,400	3.0	---	Power
						180	43	2,150	---	---	---	20.0	2,000	1,500	3.0	700	Power
CX-345	2.5	1.5	---	---	---	180	33	1,350	---	---	---	26.0	1,950	1,800	3.5	780	Power
						250	50	1,550	---	---	---	32.0	1,900	1,850	3.5	1,600	Power
CX-310	7.5	1.25	---	---	---	180	12.0	1,715	---	---	---	7.0	7,000	1,100	8.0	---	Power
						250	22	1,800	---	---	---	10.0	6,000	1,330	8.0	340	Power
						350	31	1,950	---	---	---	16.0	5,150	1,550	8.0	925	Power
CX-350	7.5	1.25	---	---	---	425	39	1,950	---	---	---	18.0	5,000	1,600	8.0	1,540	Power
						300	54	1,500	---	---	---	35	2,000	1,900	3.8	1,500	Power
						350	63	1,400	---	---	---	45	1,900	2,000	3.8	2,350	Power
						400	70	1,300	---	---	---	55	1,800	2,100	3.8	3,250	Power
						450	84	1,550	---	---	---	55	1,800	2,100	3.8	4,650	Power

NOTE:—Divide C bias resistor value in ohms by number of tubes paralleled (or push pulled) to get proper C bias resistance.

so on. Inasmuch as the exact resistance values can be determined precisely in advance, due to positive and known conditions in the circuit, there is no longer need for trying different resistance values as in the past. Therefore, the resistor can be made to be permanently incorporated in the circuit, and now takes the form of the pigtail resistor, which is soldered in place.

An inspection of any of the more popular makes of radio sets discloses pigtail resistors scattered about the wiring. It may be surprising to learn that the resistors, in the better type sets, are usually of the metallized type, using a metallized filament enclosed in a glass tube, similar to the well-known grid leak, for modest current-handling requirements, or using a metallized filament enclosed in a heavy ceramic tubing in the case of the power-ohm for

handling heavy current. The ceramic mass serves to radiate the heat generated in the filament, resulting in a greater current-handling capacity. Today, the metallized powerohms are available in 1/2 watt, 1 watt and 2 watt capacities, as well as in a wide range of resistance values, with cast metal ends for application in clip holders, or again with tinned copper pigtails cast directly into the cast metal ends for permanent application in any circuit.

High Voltage Condensers

IT is noted in the recent booklet entitled "Audio Transformers By Sangamo," printed by the Sangamo Electric Co. at Springfield, Ill., mention is made of condensers within specially close limits to rated capacity. High voltage condensers with an a. c. test

rating of 1750 and d. c. test rating of 2500 volts are available in capacities from .002 to .01 mfd, while in the 3500 volt a. c. test and 5000 volt d. c. test these high voltage condensers are available in capacities of .00004 to .002 mfd. Those interested in Sangamo products may secure a copy of the booklet referred to by addressing the company at the address given above.

Line Ballasts Eliminate Guesswork

THE outstanding refinement in this season's socket-power radio sets, according to J. E. Smith, President, National Radio Institute, is the line ballast for the automatic regulation of the applied line voltage. This device is practically essential, for line voltage is the last variable or uncertain

factor involved in the refined a. c. set. Many radio sales have heretofore been lost in territories with low line voltages, because of the poor performance, and, contrariwise, many hundred hours of tube life have been sacrificed in territories with high line voltages. With the line ballast, however, a uniform and satisfactory performance is assured.

Library Needs Old Copies

WE are advised by the director of the New York Public Library, 5th Avenue and 42nd Street, New York City, N. Y., that they are in need of all numbers of Volumes 1 to 7 inclusive of this magazine in order to complete their files.

Inasmuch as these numbers are now out of print at this office, the only possible manner in which the library could complete its files would be through the generosity of some of our readers who may have certain volumes which they no longer care to retain. We feel sure the New York Public Library would be very grateful for any such additions to their files.—Editor.

Interference Hints

WE are making excerpts from a recent bulletin from the R. C. A. Service Division which may help other service men:—

“When Radiolas are installed in some city locations, such as apartment houses, hotels and office buildings, it is possible that the level of noise compared with the signal strength of the desired station may be such that the station cannot be received without an objectionable noise background. This noise may be defined as inductive interference from electrical devices such as elevator motors, generators, violet ray machines, professional equipment, etc. It may have no apparent radio frequency peak, or it may have a broad peak. The effect of the noise may be divided into the following three general classes:

(a) Where the noise level is zero with no antenna or ground, but is equally great on either an indoor or outdoor antenna.

(b) Where the noise is equally great with the antenna and ground either connected or disconnected.

(c) Where the noise level is greater when the outside antenna is connected than when an inside antenna is used; the inside antenna, however, not giving sufficient pick-up for satisfactory reception.

“A simple method that will usually increase the ratio of signal to noise and thereby obtain satisfactory reception is as follows:

“Erect as long and high an antenna as possible. and then couple it to the

antenna lead of the receiver through a small coupling condenser. This condenser with a 200 foot antenna should be about .0003 mfd. in capacity. The effect of the long antenna is to increase the pick-up to a point where it will be proportionately higher than the noise level. The series condenser then reduces the effective antenna capacity and limits the input energy to the receiver, thereby avoiding any broad tuning effects that might be present in some receivers. It does not, however, change the noise to signal ratio and generally a setting of the volume control that will give room volume, will not be sufficiently advanced to give a noise background.

“In the case of Radiola 44 and 46 this method will give good results, but the series condenser must not be greater than .00025 on large antennas.

“If the foregoing suggestions do not give the desired results one of the following remedies must be applied, the exact remedy depending on the particular location and conditions.

“In (a) where the noise level is zero with no antenna or ground connected, but equally great with either an indoor ant that the interference is not being brought into the receiver over the power supply lines. It has been found in such cases that an antenna five feet long in-

Eveready Tube Characteristics

Type Number	Filament Terminal Voltage	Filament Current (Amperes)	Detector Bias (Megohms)	Detector "B" Voltage	Detector Plate Current (M. A.)	Amplifier "B" Voltage	Amplifier "C" Voltage	Amplifier "C" Bias Resistor (Ohms)	Screen Grid "B" Voltage	Screen Grid Current (M. A.)	Plate Resistor (Ohms)	Amplifier Plate Current (M. A.)	A. C. Plate Resistance (Ohms)	Mutual Conductance (Micromhos)	Voltage Amplification Factor	Maximum Undistorted Output (Milliwatts)	Purpose
ER-201-A	5.0	.250	---	---	90	4.5	---	---	---	---	---	2.5	11,000	725	8	15	Det. & Amp.
					135	9.0	---	---	---	---	3.0	10,000	800	8	55	Det. & Amp.	
ER-226	1.5	1.05	---	---	90	6.0	1,700	---	---	---	---	3.5	9,400	875	8.2	20	Amplifier
					135	9.0	1,500	---	---	---	6.0	7,400	1,100	8.2	70	Amplifier	
					180	13.5	1,800	---	---	---	7.5	7,000	1,170	8.2	160	Amplifier	
ER-227	2.5	1.75	---	---	90	6.0	2,000	---	---	---	---	3.0	10,000	900	9.0	20	Det. & Amp.
					135	9.0	1,800	---	---	---	5.0	9,000	1,000	9.0	65	Det. & Amp.	
					180	13.5	2,250	---	---	---	6.0	9,000	1,000	9.0	140	Det. & Amp.	
ER-224	2.5	1.75	---	---	180	1.5	---	75	---	---	---	4.0	400,000	1,050	420	---	Det. & Amp.
					180	3.0	---	90	---	---	---	3.5	425,000	1,050	450	---	Det. & Amp.
ER-112-A	5.0	.250	---	---	90	4.5	800*	---	---	---	---	5.5	5,300	1,500	8.0	30	Power
					135	9.0	1,300*	---	---	---	7.0	5,000	1,600	8.0	120	Power	
					180	13.5	1,350*	---	---	---	10.0	4,700	1,200	8.0	300	Power	
ER-171-A	5.0	.250	---	---	90	16.5	1,700*	---	---	---	---	10.0	2,500	1,200	3.0	130	Power
					135	27.0	1,700*	---	---	---	16.0	2,200	1,360	3.0	330	Power	
					180	40.5	2,000*	---	---	---	20.0	2,000	1,500	3.0	700	Power	
ER-245	2.5	1.5	---	---	150	28.0	1,200	---	---	---	---	24.0	2,100	1,700	3.5	400	Power
					200	38.0	1,400	---	---	---	25.0	2,000	1,750	3.5	900	Power	
					250	50.0	1,500	---	---	---	32.0	1,900	1,850	3.5	1,600	Power	
ER-250	7.5	1.25	---	---	250	45.0	1,600	---	---	---	---	28.0	2,100	1,800	3.8	900	Power
					350	63.8	1,400	---	---	---	45.0	1,900	2,000	3.8	2,300	Power	
					450	84.0	1,500	---	---	---	55.0	1,800	2,100	3.8	4,600	Power	

*Resistance values based on D. C. operation with grid return to negative filament. For A. C. operation add 2.5 volts to the grid bias and change grid resistance accordingly.

DeForest Tube Characteristics

Type Number	Filament Terminal Voltage	Filament Current (Amperes)	Detector Bias (Megohms)	Detector "B" Voltage	Detector Plate Current (M. A.)	Amplifier "B" Voltage	Amplifier "C" Voltage	Amplifier "C" Bias Resistor (Ohms)	Screen Grid "B" Voltage	Screen Grid Current (M. A.)	Plate Resistor (Ohms)	Amplifier Plate Current (M. A.)	A. C. Plate Resistance (Ohms)	Mutual Conductance (Micromhos)	Voltage Amplification Factor	Maximum Undistorted Output (Milliwatts)	Purpose
401A	5	.25	---	22.5-45	---	45	1½	1,666	---	---	---	.9	18,500	430	8	---	R.F. Det. A.F.
						67½	3	1,765	---	---	---	1.7	14,000	570	8	---	R.F. A.F.
						90	4½	2,250	---	---	---	2	10,000	725	8	---	R.F. A.F.
426	1.5	1.05	---	---	---	135	9	3,600	---	---	---	2.5	10,500	750	8	---	A.F.
						90	6	1,351	---	---	---	3.7	9,400	870	8.2	---	R.F. A.F.
						135	12	4,000	---	---	---	3	10,000	820	8.2	---	A.F.
427	2.5	1.75	---	45	---	180	16½	4,342	---	---	---	3.8	9,400	870	8.2	---	A.F.
						90	6	2,000	---	---	---	3	11,300	725	8.2	---	Det. R.F. A.F.
						135	9	1,800	---	---	---	5	11,000	820	8.2	---	A.F.
424	2.5	1.75	---	---	---	180	3	697	90	.3	---	4	400,000	1,050	420	---	R.F.
						180	3	697	90	.3	---	4	400,000	1,050	420	---	R.F.
						135	1.5	909	45	.15	---	1.5	850,000	350	290	---	R.F.
412A	5	.25	---	45	---	90	3	958	---	---	---	4.8	5,300	1,500	8	---	Det. A.F.
						135	9	1,551	---	---	---	5.8	5,000	1,600	8	195	A.F.
						157½	10½	1,329	---	---	---	7.9	4,700	1,700	8	---	A.F.
471A	5	.5	---	---	---	90	16½	1,500	---	---	---	11	2,500	1,200	3	---	A.F.
						135	27	1,687	---	---	---	16	2,200	1,360	3	---	Pwr.
						157½	33	1,833	---	---	---	18	2,150	1,400	3	---	Pwr.
410	7.5	1.25	---	---	---	180	40½	2,025	---	---	---	20	2,000	1,500	3	700	Pwr.
						180	12	1,714	---	---	---	7	7,600	1,100	8.5	---	Pwr.
						250	18	1,500	---	---	---	12	6,300	1,330	8.5	---	Pwr.
445	2.5	1.5	---	---	---	350	27	1,687	---	---	---	16	5,600	1,500	8.5	---	Pwr.
						425	35	1,891	---	---	---	18.5	5,450	1,550	8.5	1,500	Pwr.
						180	33	1,269	---	---	---	26	2,150	1,350	3.5	---	Pwr.
450	7.5	1.25	---	---	---	250	50	1,562	---	---	---	32	2,000	1,750	3.5	1,600	Pwr.
						250	45	1,464	---	---	---	28	2,100	1,800	3.8	900	Pwr.
						350	63	1,400	---	---	---	45	2,000	2,000	3.8	2,350	Pwr.
						400	70	1,274	---	---	---	55	2,100	2,100	3.8	3,250	Pwr.
						450	84	1,527	---	---	---	55	2,100	2,100	3.8	4,650	Pwr.

NOTE:—471-B tube is same as 471-A except current is only .25 ampere.

NOTE:—Divide C bias resistor value in ohms by number of tubes paralleled (or push pulled) to get proper C bias resistance.

side the room picked up as much noise as when an entire outside antenna lead-in was used. This indicated that the noise is within the building and, in the case of the outside antenna, is being picked up on that portion of the lead-in that enters and goes through the building. In such cases the receiver should be located close to the point where the outside lead-in enters the building. If this is impractical the set can be placed in any location and a copper braid placed over the inside portion of the lead-in wire. This braid is not grounded. If the noise level is still appreciable a good receiver ground with a short lead must be obtained. A long lead is not desirable, as it may pick up noise.

"In (b) the noise is picked up with no antenna or ground connected to the receiver. This indicates the noise is entering the receiver through the power lines. In this case filters must be placed in the power supply at the source of the noise or at the receiver, depending on conditions.

"The usual procedure for connecting a filter is, the condensers are connected

next to the device causing the interference. When connected next to a radio set the connections should be reversed. The condensers in this case are connected to the line side of the choke.

"If the trouble is cleared up in this manner when the antenna and ground are disconnected, but again appears with the use of the antenna system, the remedies suggested in (a) must also be applied.

"In (c) the noise is greater when the outside antenna is connected than when an inside antenna is used. The use of the inside antenna, however, does not give sufficient pick-up for satisfactory reception. In this case the pick-up is probably occurring on the lead-in wire between the set and the antenna. Copper braid should be placed over the entire lead-in from the receiver to the flat portion of the antenna. Also changing the direction of the antenna should be tried and the lead-in connected from the end of the antenna that gives the best results. The copper braid should not be grounded. The conditions existing in any locality must be analyzed and placed in its correct category. A

little patience and experimenting will usually result in a satisfactory installation."

Jewell Has Service Data

PRESENT day radio service has none of the slap-bang, hit-or-miss guess work of the past if we are to consider the type of information prepared for the service men who work on factory built receivers.

Guesswork has been supplanted by actual figures. Operating values of voltage, current, resistance and capacity are known. A departure from operating values at once tells the trouble and most likely the cause.

Dope on Radiolas

Recently we came across the Jewell instructions for servicing radio receivers, prepared by the engineering department of the Jewell Electrical Instrument Co. And in it we found a wealth of material of genuine help to the service man. Because of many requests for operating values on the Radiola line we

(Continued on page 129)

Grebe Synchrophase Seven A. C. Set

SHOWN schematically on this page is the diagram of the Grebe Synchrophase Seven a. c. set and power supply made by A. H. Grebe & Co., Richmond Hill, N. Y. The receiver uses seven tubes, five 226, one 227, one 171-A and one 280 rectifier.

The input stage of the receiver is arranged for employment with either a long or a short antenna. The grid circuits of the first, second, third and fourth tubes are identical as far as tuning and suppression are concerned. The familiar Grebe binocular coils are used to couple the tuned stages. These coils are space wound with 20-38 Litz wire for efficiency and are carefully matched for assembly in the set. This type of radio frequency transformer possesses practically no external field. The only interstage shielding consists of small plates between the tuning condensers preventing feedback between the grid leads of the tube. Necessity for further shielding is eliminated by the use of the binocular coils and the proper arrangement of the wiring.

The volume control used on the receiver is a 2500 ohm maximum variable resistance placed across the primary of the last radio frequency transformer where it affords complete control of the incoming signal before reaching the detector so excessively

strong signals will not introduce distortion in that stage by overloading the tube. A tone color control is also provided and consists of five fixed condensers arranged on a switch so that they are cut in across from the grid to the ground of the 171-A power tube.

Local Reception Switch

Another novel connection which is used for local work consists of a switch of the plate circuits of the first r. f. amplifier, which when set on locals places a fixed resistance across the primary of the second radio frequency transformer and allows the receiver to be operated against strong local stations without overloading. When it is desired to pick up distant signals the switch is open and the fixed resistance is eliminated from the circuit.

The power unit has only two direct current terminals and delivers a total rectified voltage to the receiver terminal strip through the cable to be divided as required by the resistances inside of the set. Between the filament and C minus a 2,500-ohm resistor is inserted which provides the desired C bias for the power tube. A 300-ohm resistor between the 226 filament circuit and deck provides the C bias for these tubes in the same manner as that of the power tube. Finally a 20,000-ohm resistor be-

tween the 226 plate supply tap and detector drops the voltage on the detector plate to the desired value. Since no grid bias is required on the detector the cathode is grounded directly to the set.

Balancing the Hum

This system of voltage distribution permits Grebe to carry out a scheme of 120 cycle hum elimination. The filter system designed allows some hum to remain in the d. c. supply to the set. This is later balanced out in the set through the voltage distribution system. The amount of hum is in the right phase and just sufficient to cancel the effect of hum remaining in certain parts of the set without the necessity for variable hum adjustment. An important feature of the hum balance system is the 1 mfd. condenser and the 4,500-ohm resistance in series with the B plus terminal and the power tube center tapped filament resistor. The by-pass condensers between intermediate and detector voltage supply points and ground provide a resistance capacity filter eliminating the feed-back generally termed motor-boating. The two small 1 mfd. condensers between the ground and two filament bus bars of the 226 tubes prevent radio frequency feed-back which might cause the receiver to oscillate.

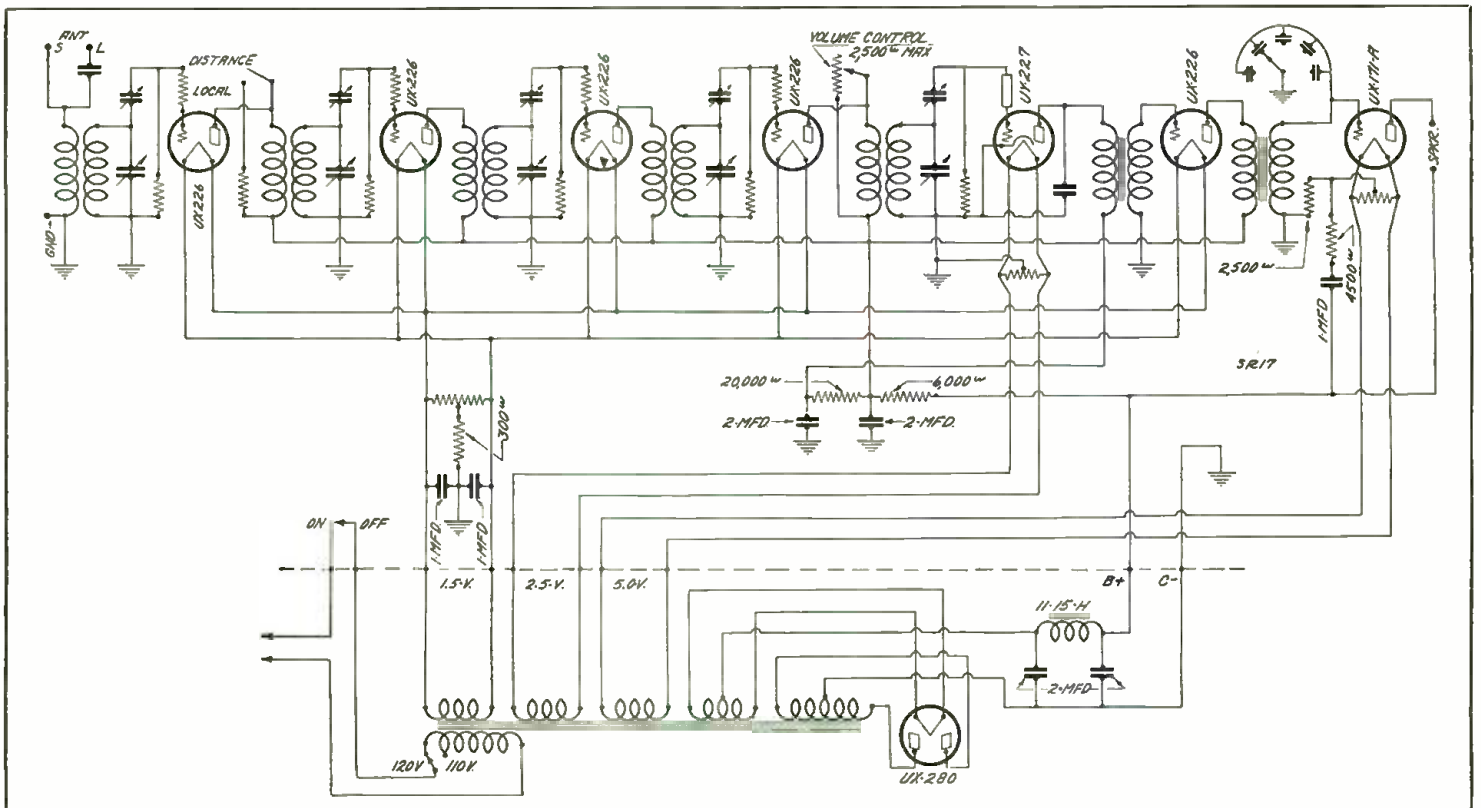

Fig. 1. Schematic wiring of the Grebe Synchrophase Seven A. C. and its power supply is shown in the above illustration

Stromberg-Carlson 635-636 Receiver

RECEIVER models 635 and 636 made by the Stromberg-Carlson Telephone Mfg. Co., Rochester, N. Y., and shown schematically on this page are self contained. All tubes of the receiver with the exception of the output tube and the rectifier are the 227 heater type. The output tube is the 171-A, while the rectifier is the 280 full wave.

Tuning System

The tuning system consists of one tuned antenna stage and three stages of tuned and neutralized radio frequency amplification. The antenna stage is a tuned coupling stage, the r. f. transformers are completely shielded, while one control operates all tuning capacitors simultaneously. The tuning capacities are aligned electrically by means of padding capacitors connected across them. The r. f. stages are stabilized by means of balancing capacitors and neutralizing inductances which are a part of the secondary coils of the r. f. transformers.

Plate rectification or grid bias method of detection is employed. Two stages of high quality transformer coupled audio amplification are used. The secondary of each audio transformer is shunted with a 1 megohm resistor to obtain the desired audio frequency characteristic. The output of the audio system is coupled to the loud speaker by means of the 60 henry choke and a 2 mfd. capacitor. A correctly designed high frequency cut-off type of

audio filter is included in the audio output system. Insulated tip jacks are provided in the rear of the chassis for loud speaker connection. A phonograph pick-up jack is provided in the front panel.

Volume Control

The volume control consists of two separate units operated simultaneously by the same knob. The primary of the antenna transformer has a 10,000-ohm potentiometer shunted across it with a variable contact knob. This controls the amount of signal admitted into the radio frequency amplifier. The second unit is a 10,000-ohm variable resistor shunted across the primary of the third r. f. transformer and controlling the amount of signal admitted into the detector.

The heaters of the three r. f. and first audio tubes are connected in parallel but with separate twisted pair connections to each tube from the power transformer secondary which supplies approximately 2.3 volts, and has a grounded center tap for hum balance. A separate secondary supplies approximately 2.3 volts to the detector tube heater. A 10-ohm potentiometer with its variable contact grounded for hum balance is shunted across the current supply of this tube. The filaments of the audio output tube and the dial light are connected in parallel and are supplied with approximately 4.5 volts. A 20-ohm potentiometer with its variable

contact grounded for hum balance is shunted to this current supply.

The plates of the radio frequency and first audio tubes are supplied with approximately 110 volts d. c., the detector plate with 36 volts and the audio output tube with 180 volts. The r. f. and first audio plate supply is by-passed to ground by a 3 mfd. capacitor. The plate supply of the radio frequency tubes is by-passed to the cathode of each radio frequency by a .5 mfd. capacitor. The detector plate supply is by-passed to ground by a 3 mfd. capacitor. Any radio frequency current present in the detector plate circuit is by-passed to cathode by a .002 mfd. capacitor.

Grids of the r. f. detector and first audio tubes are all returned to ground. Grids of the r. f. and first audio tubes are biased negatively approximately 5 volts with respect to the cathode by means of a 1,500-ohm resistor between each cathode and ground. The detector tube grid is biased negatively approximately 3.5 volts with respect to the cathode by means of a 10,000-ohm resistor connected between the cathode and ground. These biasing resistors are by-passed by .5 mfd. capacitors in the r. f. stages and by a 1 mfd. capacitor in the detector stage. Power equipment supplies approximately 40.5 volts bias to the grid of the 171A.

The primary circuit of the power transformer has a high-low switch which compensates for a high or low line.

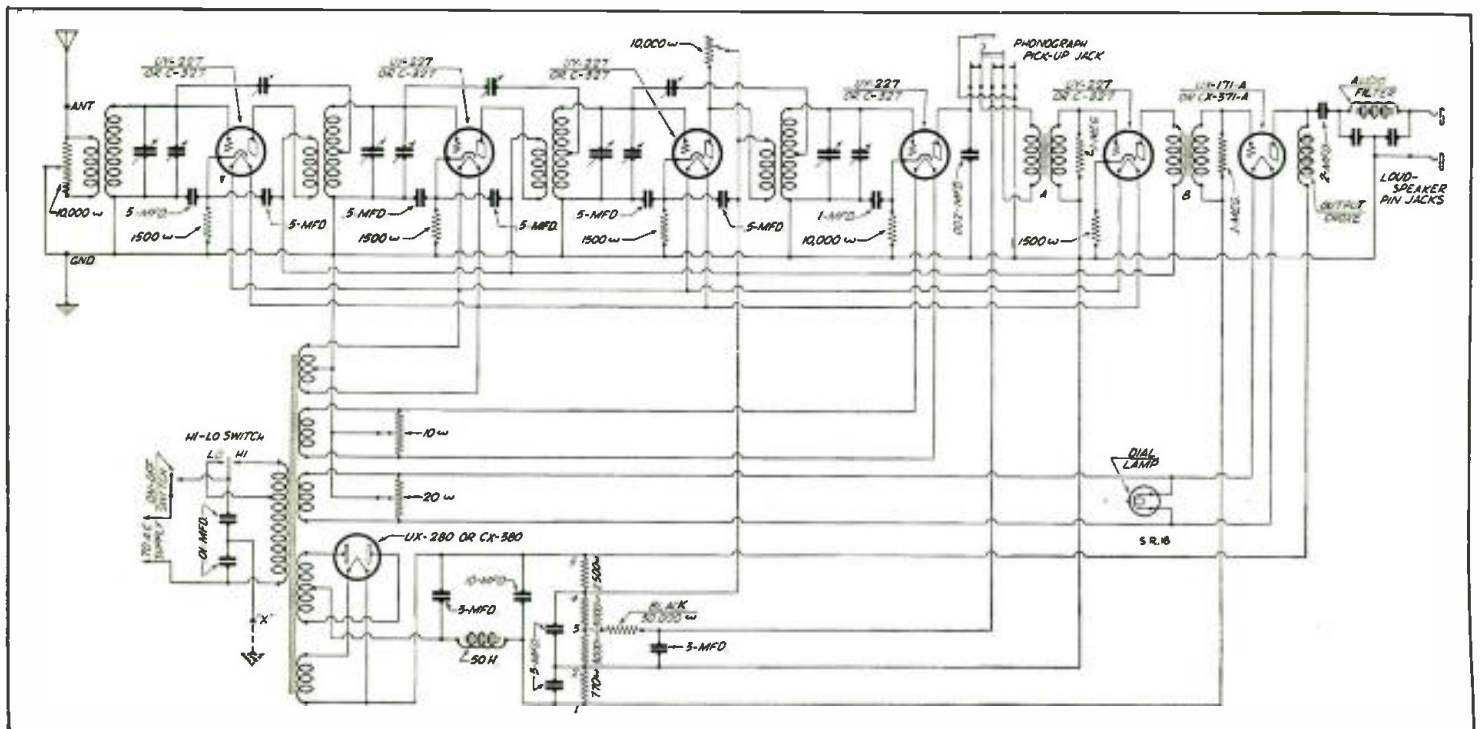

Fig. 2. In this schematic circuit are shown all of the details of the Stromberg-Carlson 635 and 636 receiver complete with power supply

Federal Model "H" A. C. Receiver

MADE by the Federal Radio Corp., Buffalo, N. Y., the model "H" a. c. receiver is described on this page. It is shown in the schematic Fig. 3 which is both the receiver and the power supply portion.

As will be seen from the circuit diagram no grid suppressors are inserted to prevent oscillation. Due to the placing of the r. f. coils mutually at right angles and due to shielding the variable condensers, the receiver is stable and free from oscillation. The volume control is a 500,000 ohm potentiometer shunted across the secondary of the last radio frequency transformer.

The three tuning condensers are of the sliding plate type and are ganged to the single dial control. A vernier knob is provided to the right of the main tuning control which by means of a link motion causes a change in ca-

capacity of the antenna condenser sufficient to allow for the different antennas that may be used.

Power Supply Compact

The power unit is very compact and is housed inside the cabinet directly behind the chassis. A cable is used to feed all of the A, B and C voltages from the power unit to the receiver. The power transformer primary has three taps which provide for voltage ranges of 100 and 110, 110-120 and 120-130 volts. There are six secondaries on the transformer instead of the usual five, one lights the 280 rectifier, one provides plate voltage of the 280 rectifier, one lights the power tube and pilot light, one the r. f. tube, one the detector and one the first audio frequency tube. The first audio frequency tube is heated from a separate winding

in order that hum may be kept at the lowest possible level. It will be noticed that there are two 40 ohm variable resistances across two of the secondaries. These are adjusted so that all trace of hum disappears and need not be readjusted by the owner.

The output of the rectifier tube feeds into the filter system which consists of the usual two filter chokes and filter condensers. Fixed resistors are used to secure the proper plate voltages for the detector and amplifier tubes. C biases are secured by causing the plate currents of the respective tube to flow through resistors inserted in the center tap lead. It will be noted that with this particular arrangement the frame of the receiver is both at C minus and B minus potential and that all grid returns are simply grounded to get the proper bias.

Set delivers 1½ watts to the speaker.

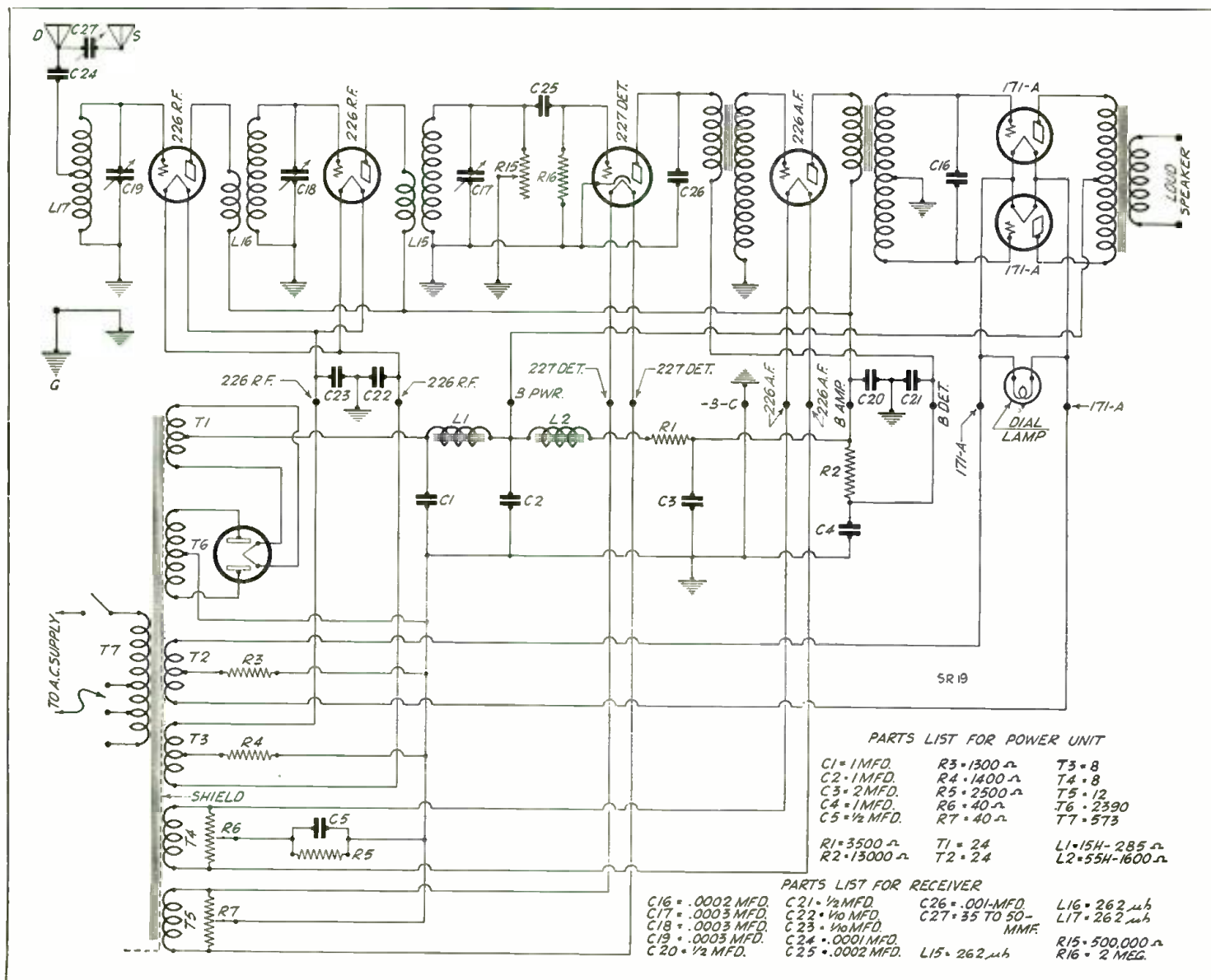

Fig. 3. The schematic diagram printed above gives the electrical arrangement of the Federal Model "H" receiver and its power supply

Models 28 and 29 Bosch Receivers

THE model 28 receiver made by American Bosch Magneto Corp. at Springfield, Mass., consists of the standard chassis and standard push-pull power pack mounted in a table model cabinet. The two units are covered by a single shield and the receiver and power unit are already interconnected. Installation of this model consists in connecting the reproducer, antenna, ground, attachment cord, and inserting the tubes.

Use Set Tester

A variable tap switch is provided to take care of line voltages between 100 and 130 volts. It is absolutely essential that the service man determine the maximum line voltage to which the receiver is to be connected. Voltage readings should be made depending on load conditions of the line so that the best average voltage may be ascertained. For this purpose the service man should either use the model 537 Weston a. c. and d. c. radio set tester or the Jewel model 199 a. c. and d. c. set analyzer.

When the receiver is in operation it is desirable to interchange the location of the type 226 tubes to obtain maximum performance. Always switch the receiver off by means of the main switch before changing tubes. Any type 226 tube which works poorly in any radio

frequency socket should be placed in the first audio socket.

On the model 28 the speaker jacks are connected on the rear of the power unit at the left of the receiver. These jacks fit any standard cord tips. Since the output transformer of the push-pull stage eliminates direct current in the speaker jacks attention to polarity is unnecessary.

Adjusting R. F. Stages

The fact that no signal will come through a stage which is perfectly balanced, providing the tube filament is not lighted, is utilized to adjust the receiver should it become necessary to balance the radio frequency stages.

A modulated radio frequency oscillator made by Bosch is used to provide a signal for the receiver to pick-up. A powerful local broadcast station may also be employed, preferably one coming in at from 30 to 50 on the dial scale. When using the oscillator turn the station selector dial to about 40 degrees. Then tune the oscillator until the signal is picked up by the receiver. When using the broadcast signal simply tune it in for maximum volume.

Make sure that the clarifier and selector dial are set at a position of maximum volume. This is important. Turn the volume control fully on.

Now remove the tube from the first radio frequency socket and replace it by a type 226 which has had one of its filament prongs sawed off. The tube must otherwise be in good condition. Do not use a burned out tube.

Due to the fact that the one filament prong has been removed the tube will not light and if the stage is in balance no signal will be heard. If, however, the signal is heard, adjust the nut of the first r. f. balance condenser with the service tool until the signal disappears. If the nut is turned beyond the balance point the signal will again come in. Leave the nut at the point of minimum volume. This completes the balance of the first stage. Second and third stages are balanced in exactly the same manner using the adjusting nut of the second r. f. balance condenser and the third r. f. balance condenser.

Align After Balancing

Alignment of the set must be done after the receiver is balanced. To do this simply adjust the nut of the second r. f. alignment condenser, the third r. f. alignment condenser and the detector alignment condenser to the point of maximum volume. The regular tubes are employed in this adjustment, the special balancing tube not being employed.

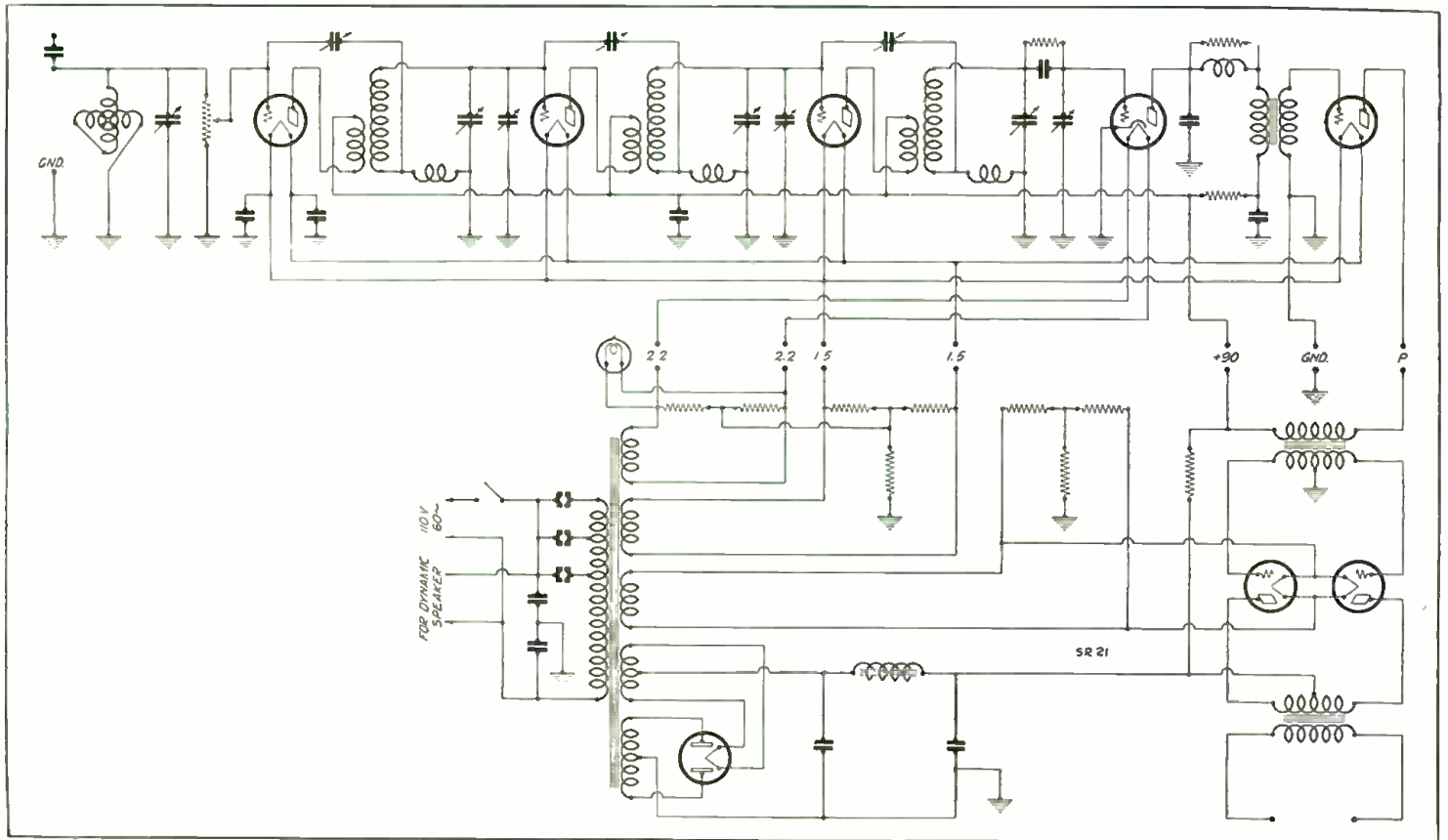

Fig. 5. This wiring diagram gives the schematic circuit of the Bosch Models 28 and 29 described on this page

Brunswick No. 3KRO with Panatrope

BRUNSWICK model 3KRO is made by the Brunswick-Balke-Collender Co. of Chicago. This particular model has in it the Panatrope with Radiola. The circuit used in the X802 radio chassis is a six tube radio frequency circuit employing an untuned input, three stages of tuned radio frequency, detector and two audio stages.

Untuned Input

The untuned input consists of a 2000 ohm resistor in the form of a potentiometer, the antenna and ground being connected to the ends of the resistance and the contact arm connected to the grid of the first r. f. amplifier tube. The variable resistance serves as a volume control, the resistor being in two sections, one of which is of a low resistance and the other high resistance in order to give gradual adjustment.

The necessity for stabilizing resistors has been eliminated by the use of three coil (two primaries and one secondary) transformers in the second and third r. f. stages. In the first r. f. the transformer has an auxiliary secondary winding which is used in conjunction with a small variable capacitor for regulating regeneration in the second 226. The small capacitor is adjusted at the factory and a paper seal placed over the hole in the chassis. If this capacitor is ever readjusted, place new seal over hole.

Any undesirable hum in the speaker must be minimized by one or more of the following methods: Reverse the connections of the power supply plug; interchange the 226 tubes until a satisfactory arrangement is found; make sure that the 280 rectifier is not a low emission tube. It is possible a section of the condenser across the 226 filament

Possible Troubles

Audio howl may be caused by one or more of the following defects: Compensating condenser not adjusted correctly. Open connections to the a. f. condensers on the under part of the chassis, or open connections in one of the condensers. An open ground connection on the radio chassis or a poor ground installation. Open radio frequency coil. Open or shorted resistor in the socket power unit. In some cases it may be found that the 227 is causing the audio howl and if such is the case the tube should be replaced.

The schematic diagram of the socket power unit is shown in Fig. 8. It will be seen that the 280 is used as a rectifier. Filaments of all tubes are supplied with raw a. c. at the proper voltages, three mid tapped resistors being used to minimize hum. Grid bias voltages are obtained by using the voltage drop across resistances connected in the plate return lead. Due to

use of a series resistance arrangement for securing the different plate voltages, all tubes must be in good condition in order to prevent overloading of other tubes. This method also makes possible the use of smaller filter capacity.

Inasmuch as the impedance output unit is incorporated in the socket power unit, the phone tip jacks are placed in a convenient position in the lower part of the power supply.

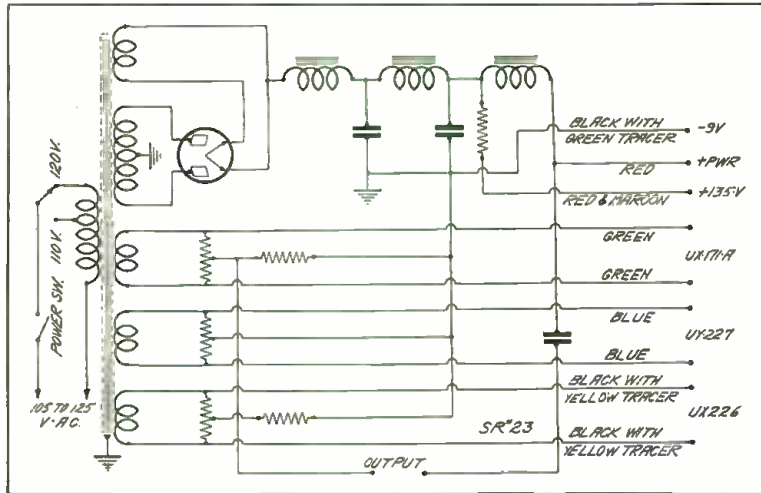

Fig. 8. In this diagram is shown the schematic circuit of socket power unit X-341 used with the 3KRO equipment shown on this page

is shorted. This condenser is one of the two located on the under side of the chassis and is composed of two 1/2 mfd sections with the center tap grounded. A defective center tapped resistor in the socket unit will also cause abnormal hum. Proper contacts should be made at all grounding connections on the chassis in order to prevent undesirable hum. Improper connections may also cause unsatisfactory operation.

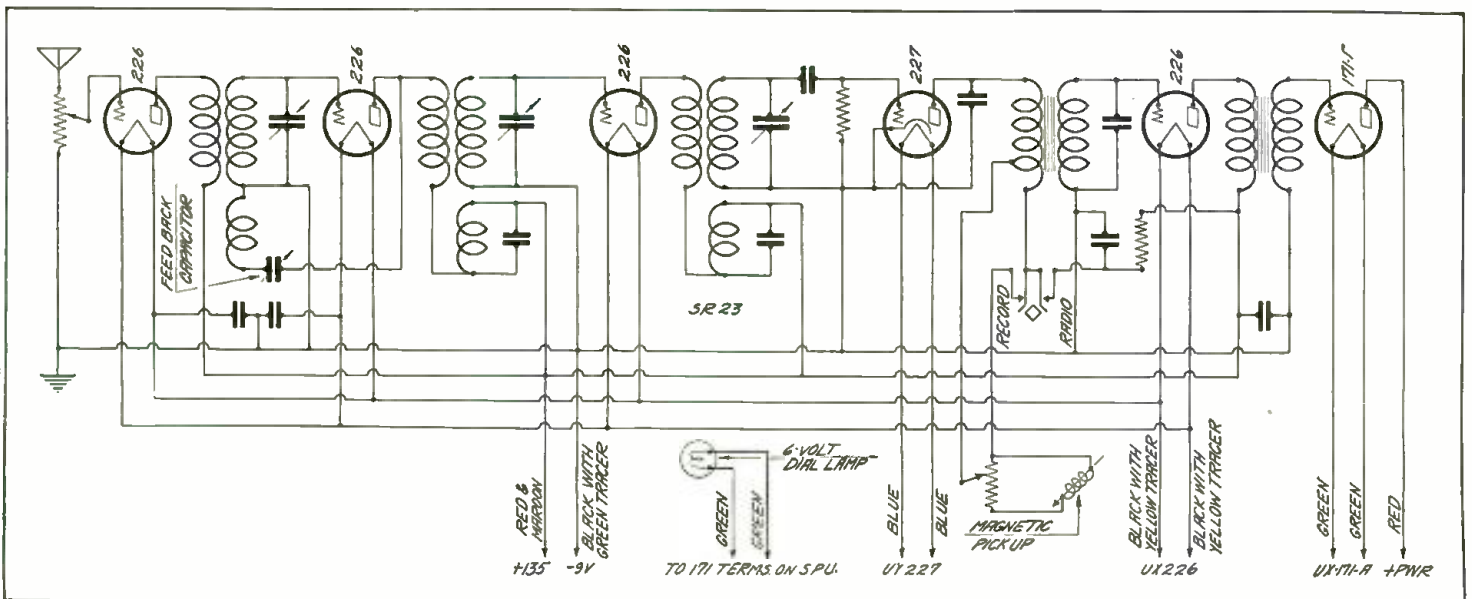

Fig. 9. The schematic diagram of the Brunswick Model 3KRO shows electrical connections of the chassis No. X802

Sonora De Luxe Highboy Model 5R

USING the Loftin and White circuit, the receiver illustrated on this page is made by the Sonora Phonograph Co. of New York, N. Y. The tuner unit consists of three stages of tuned r. f. and detector. The circuit is combined electro-magnetic and electro-static, constant coupled tuned r. f.

Four Tuned Stages

Tuning is effected by means of four variable condensers. The rotating plates operate from a master shaft and are grounded to the tuner case. Fixed plates are insulated from ground and connected to the grid of the corresponding tube. The variable condenser on the right-hand end of the master shaft is the antenna tuning circuit condenser. The capacity of this condenser may be slightly changed without disturbing the setting of the other tuning condensers by means of the antenna fine tuning control directly below it. This adjustment will be found quite helpful for distant reception for cutting out interference from other broadcasting stations operating on a wave near the one being received.

Each variable condenser has a small adjusting fin or blade mounted close to one end of the bank of stationary blades and is grounded to the case. This blade adjusts the capacity of the condenser so

that maximum amplification and sharp tuning is obtained for any wavelength throughout the entire range. If the setting of this blade has been altered it will reduce the sensitivity of the set and may be readjusted by tuning in a very weak or distant signal and reducing the volume control until the signal is barely audible. Then move the blade until maximum signal is received and lock the fin in this position.

The tuning control is operated by means of a pulley and belt attached to the center of the tuner case. The reduction or turning ratio between this shaft and the master shaft of the variable condenser is about 2.5 to 1. Geared to the master shaft is the dial which is calibrated in wavelengths. This dial rotates by means of a friction clutch. If the pointer on the radio panel of the cabinet does not indicate correctly the wavelength of the station received, the dial may be moved ahead or retarded by turning the tuning control knob until the movable plates of the variable condenser are all of the way in or all of the way out and then tightly grasping the calibrated dial with the fingers and moving the dial ahead or back to indicate the correct wavelength received. Once the dial has been set to indicate correctly the wavelength of a station received, all other readings will also indi-

cate correctly.

To control the volume on the signal received a variable resistance of about 2,000 ohms is mounted in the shielded compartment of the detector tube on the left side of the tuner cabinet.

Connections in Cable

A multi-conductor cable connects the tuner unit to the amplifier unit. This cable consists of six conductors which carry the filament and plate voltages to the tuner. A separate conductor, not included in the cable, connects the output of the detector to the primary winding of the audio amplifier unit. The antenna and ground leads are brought out separately and terminate at the antenna and ground binding posts.

The power amplifier unit consists of one stage of transformer coupled audio, one stage of push-pull transformer coupled power amplification. The primary of the first audio transformer receives its energy from the output of the detector tube. The secondary of this transformer has a separate winding for Sonora low impedance magnetic pick-up. The push-pull input transformer receives its energy from the first audio amplifier tube and supplies the grid to the two push-pull amplifier tubes. The plate leads of these tubes are connected to an output or step-down transformer.

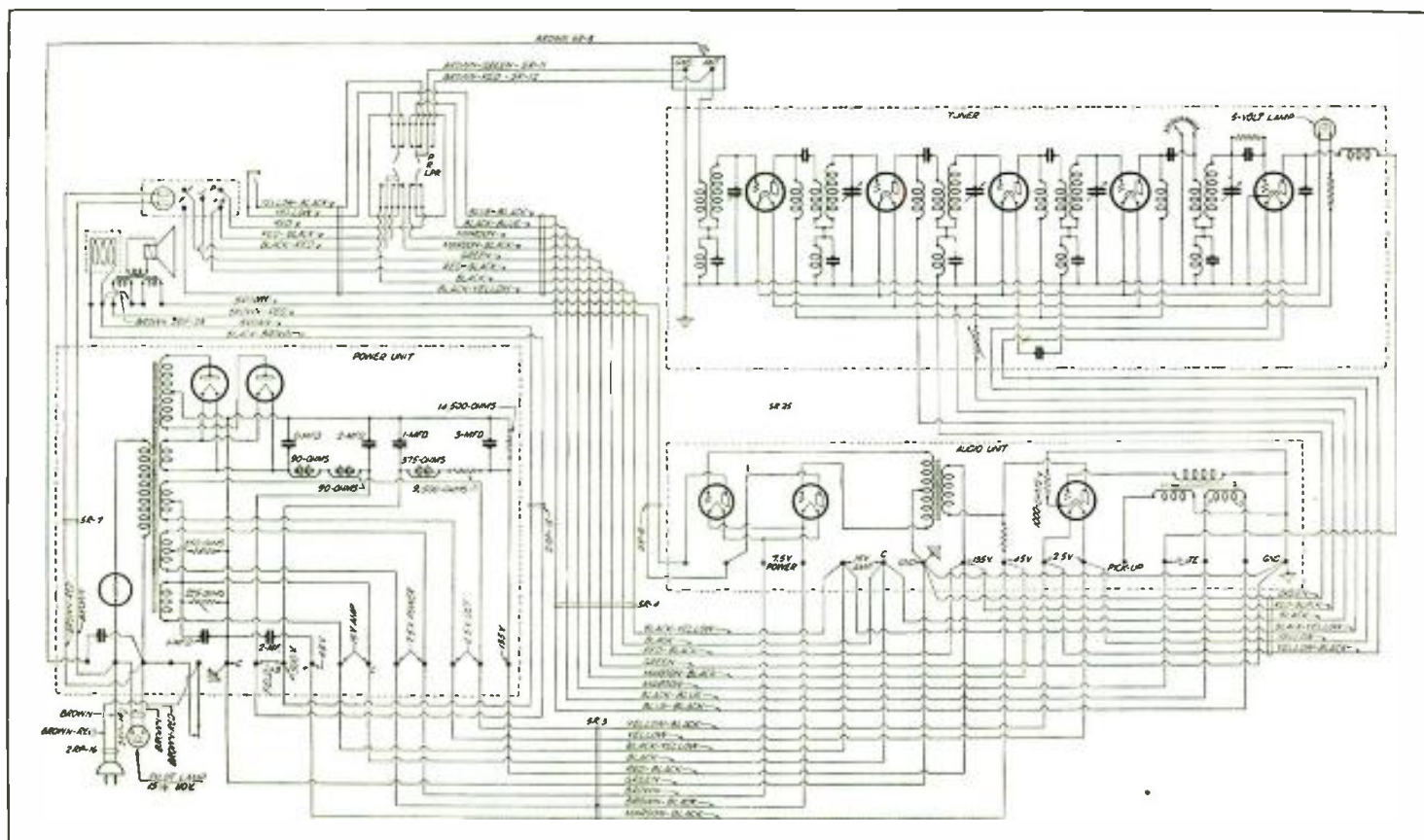

Fig. 12. In this diagram are shown the receiver constants and those of the power supply together with the inter-connecting cables for linking the two units. The model number is 5R

Philco Receiver Models 86 and 82

SHOWN schematically on this page is the Philco electric radio, models 86 and 82, manufactured by the Philadelphia Storage Battery Co. of Philadelphia, Pa.

For a service man the best method of neutralizing is by means of a dummy tube and an oscillator. When adjusting the neutralizing condensers use an antenna consisting of a single wire 25 feet long supported by insulators at least 2 feet away from any parallel wall or floor and a good ground connection. Connect the attachment plug to a light socket and have the switch in the "on" position. Set the station selector between 40 and 50. Adjust the oscillator until a signal is heard in the receiver, then tune the receiver to the strongest signal. Final setting of the receiver scale should be approximately 45. Turn the volume control to full volume.

Selecting Dummy Tube

Remove the third (next to the detector) r. f. tube, which is a 226, and insert a dummy tube. [The dummy tube may be made by selecting a 226 which gives normal results when used in a receiver and by sawing off one of the filament prongs about $\frac{1}{8}$ inch below the bakelite base of the tube. With the prong cut off at this point it will not make contact in the socket, so the filaments of the tube will not light. Carefully test a number of tubes by using them in one of the r. f. stages of the

receiver and select one which gives average normal results.]

With the regular tube removed, the signal should be strong. With the dummy inserted, the volume should diminish. Correct adjustment of the neutralizing condenser is obtained when the minimum signal point is reached. This adjustment is quite critical and should be made using a special wrench of fibre or other insulating material.

Repeat this procedure for the second r. f. and the first r. f. stage. It is important the neutralizing be done with the volume control on full and with the receiver scale setting between 40 and 50. After neutralizing receiver should not oscillate at any point on scale.

When adjusting the compensating condenser use an antenna previously described. Set the station selector between 40 and 50 and turn the range control so that the rotor is half way meshed with the stator. Do not change this position throughout the adjustment. Adjust the oscillator until a signal is heard in the speaker and then tune the receiver to the strongest signal without changing the setting of the range control. Final setting should be approximately 45. The regular tubes in the receiver are used in this adjustment.

Using a special wrench made of fibre or some other dielectric, turn the adjusting screws of the compensating condenser. With the volume control on

full shut down the output of the oscillator until the signal is barely audible. This can be done by moving the oscillator away from the receiver until the proper signal strength is obtained. Then adjust each one of the three compensating condensers until the maximum volume is obtained. It is not necessary to adjust the three in any special order, simply make sure each is adjusted for maximum signal.

It is very important that the receiver be retuned after each of the compensating condensers is adjusted. Use the station selector for this tuning. A change in the adjustment of the compensating condenser will change the station selector setting one or more divisions for maximum signal strength. Do not change the range control.

After adjusting the three compensating condensers, as explained above, then disconnect the oscillator and with the volume control of the receiver on full test the receiver to see whether or not it is oscillating. Do this by turning the station selector knob slowly the complete scale from zero to 100.

If the receiver oscillates at any point on the scale, give the first compensating condenser one-eighth to one-quarter of a turn in a clockwise direction. Do not turn it more than one-quarter of a turn, usually less will be sufficient to prevent oscillating. If this does not stop the oscillating, recheck both the neutralizing and compensating adjustments.

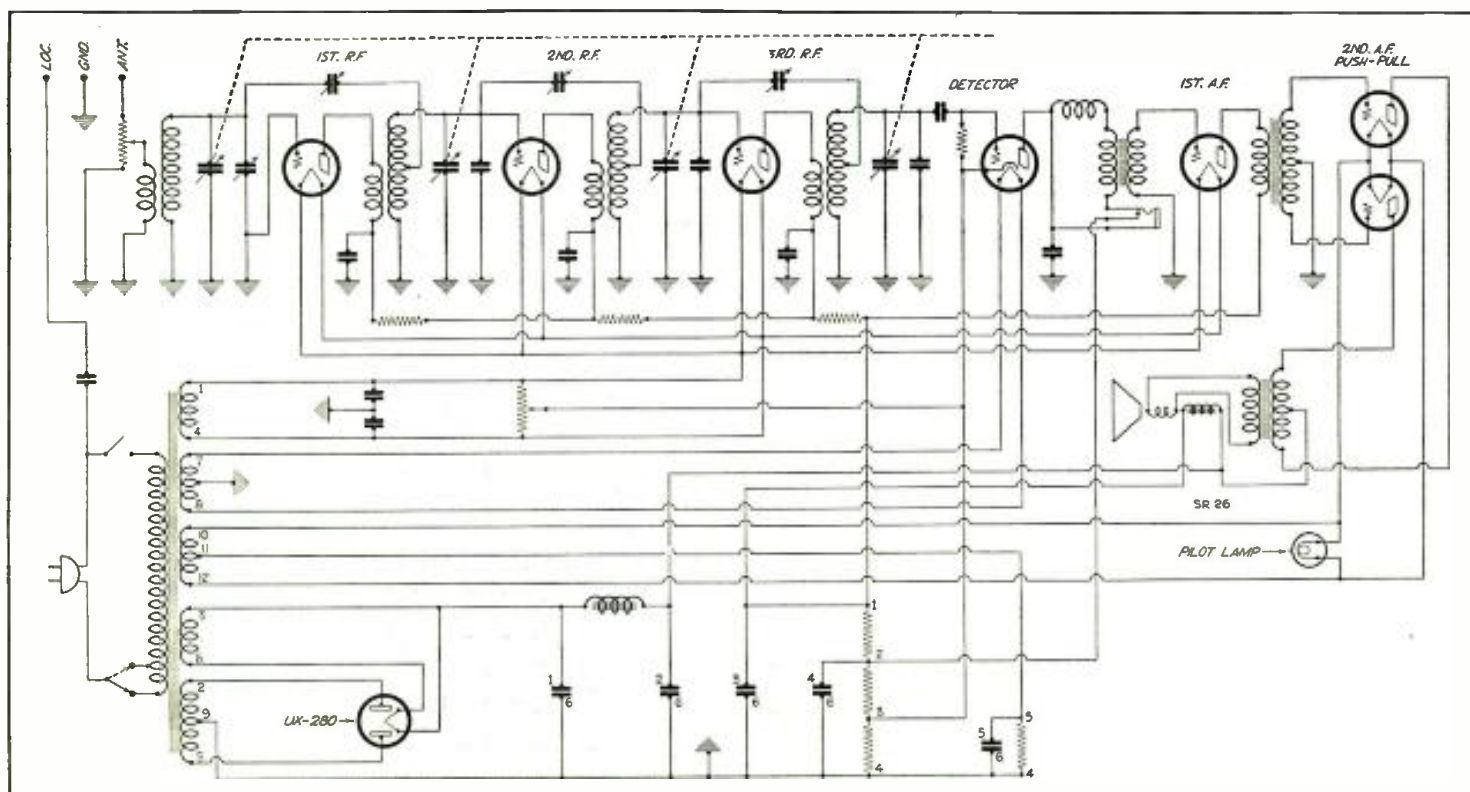

Fig. 13. This schematic diagram shows the electrical portions of the Philco receiver described on this page

Citizens 3 Tube Receiver Uses 224 Tube As a Power Detector

Compact Set Operated from Electric Light Line; Ample Volume For the Average Home

FOR some time past our readers have been desirous of having a design of a small receiver using not more than three tubes and operated from the electric light line. Ordinarily the design of such a receiver would be comparatively simple if it were only agreeable that not much was to be expected from the set in the way of performance. This is all that would be possible with the ordinary 201-A tubes or the 227 tubes, but with the introduction of the 224 and the 245 it has become easier to design a small set and still have quality reproduction with considerable volume.

Quality and Volume

While it is not intended that the receiver described in the following text should have the selectivity which other sets having a greater number of tuned stages possess, nevertheless it has creditable performance, good tone quality and ample volume for the home of the average individual.

The photograph shown in Fig. 1 will give the builder an idea of how the completed receiver should look. Looking at the rear of the photograph the detector stage at the left and the antenna stage at the right were photographed without the shielding cans. The two-gang condenser is located on the front panel and subpanel in such a manner that the trimmer sections are at the top, so the individual using the set may line up the two condensers without any difficulty. The on and off switch is seen at the left looking from the rear, while the volume control is at the right of this photograph.

Wiring is Cabled

In the picture shown in Fig. 2 the builder may see how the bottom of the

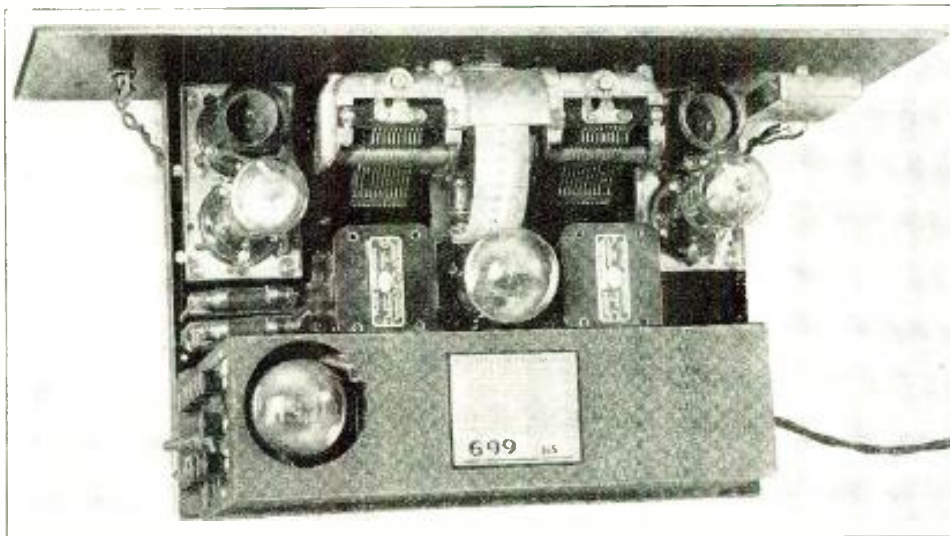

Fig. 1. The completed receiver is shown in this photograph

subpanel looks. All of the wiring has been cabled. Three subpanel brackets have been used instead of two on account of the heavy weight of the power supply, which is located at the rear of the subpanel. All parts, as condensers, resistors and radio frequency chokes are located on the under side of the subpanel, as the photograph will show.

The schematic of the power supply is shown in Fig. 3. This power unit is completely wired and has binding posts for the different voltages at one end. All that is necessary to do is to place the power pack on the back of the subpanel and anchor in place.

Smooth Volume Control

For the receiver itself the schematic diagram is shown in Fig. 4. Analyzing this diagram we see that the energy from the antenna goes through the resistor having a value of 25,000 ohms,

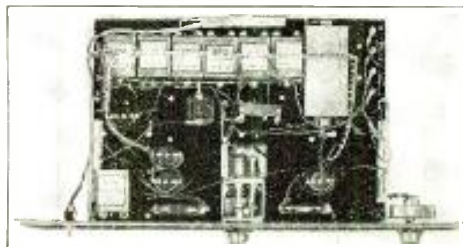

Fig. 2. Here is a bottom view of the receiver subpanel

to ground and the bottom of the primary of the first r. f. transformer which is a 132-A Silver-Marshall plug-in coil. The top of the primary goes to the movable arm of the Electrad volume control resistance. When the arm of the variable resistor is at the bottom of the resistance, the volume is least and when the arm is at the top of the resistor the energy picked up from the antenna

is at a maximum. The degree of control is very smooth.

The secondary circuit of the 132-A r. f. transformer is tuned by means of the first section of the .00035 mfd gang condenser. Its rotor is at ground potential while the stator goes to grid. The cathode of the 224 tube used in the first stage has a 400-ohm resistance between it and ground, the resistor being bypassed with a .5 mfd condenser. The plate circuit of the 224 leads into the primary of the second 132-A r. f. transformer. If it is desired, a by-pass condenser may be placed between ground and the junction of the 132-A's primary and the r. f. choke which is in the plus 180 volt line. In the schematic diagram, Fig. 4, this optional condenser is shown in dotted lines. Its value is .5 mfd.

Power Detector Tube

The secondary circuit of the second r. f. transformer is the same as that of the first as far as the inductance and capacity is concerned. However, in the cathode circuit a 15,000-ohm resistor is placed to ground, by-passed by a .5 mfd condenser. This resistor supplies necessary bias on the grid of the 224 for power detection. The plate circuit of the power detector is by-passed to ground with a .001 mfd condenser and has an r. f. choke in series with the plate and the 200 henry choke which is paralleled by a 250,000-ohm resistor. The

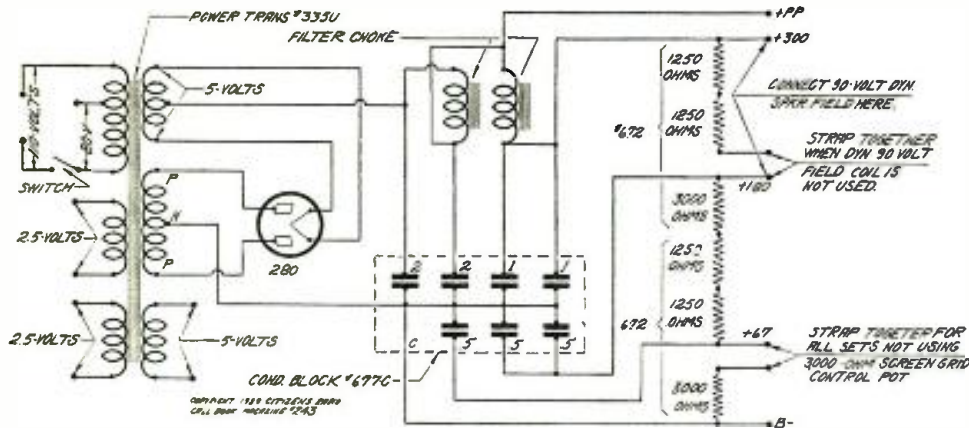

Fig. 3. Power supply schematic is shown in the above drawing

plate supply on the second 224 is also 180 volts.

Input from the plate of the power detector to the grid of the 245 is through a .1 mfd fixed condenser with a 1 megohm resistor from grid to ground. The resistor used for supplying the grid bias for that stage has a value of 1,565 ohms and is located between the center tap of the 245 filament supply and ground. It is also by-passed with a .5 mfd condenser.

The resistance values as used in this receiver have been selected after laboratory tests to give the greatest amount of gain and, therefore, would suggest that these specifications be followed religiously, especially the grid biasing resistances in the cathode circuits of the two 224 tubes. If stable operation is to be had it will be necessary to use all chokes and condensers as illustrated.

Condenser Speaker Coupling

The plate circuit of the 245 has in series with it a 30 henry choke across one end of which the speaker terminals are taken through a 1 mfd coupling condenser. The return for the other speaker terminal is through the center tap of the 10-ohm resistance across the filament supply for the 245 tube. On account of the voltage at the speaker terminal being rather high it is suggested that an exceptionally good 1 mfd condenser be used. The schematic circuit shows a 1 mfd condenser, although in the construction of the set a 2 mfd was employed.

The screen grids of the two 224 tubes have an r. f. choke in each lead and a .5 mfd condenser by-passing directly from the terminal to ground. The screens are operated at 67 volts approximately.

The voltage values as obtained from the resistors and B eliminator on the power detector have been selected so that the tube is operating just below the point where it will draw grid current.

Align at Band Middle

In operation it will be necessary to first line up the two tuned stages. To

do this turn the volume control for maximum volume on a weak station. Then with a screw-driver shift the trimmer condenser of the left section looking at the set from the front until strongest signal is heard. Then without moving the drum dial shift the right-hand trimmer section until maximum volume is secured. If the trimming is done on a station at about midway on the broadcast band it will be found that the stages will be lined fairly well throughout the entire spectrum. In making the aligning adjustment be sure that the shielded covers are in place.

Two R. F. Coil Types

There are two types of r. f. transformers that may be used in the set if desired. The 132-A was used in the model described in this issue and it has a 50-turn primary. The 132-B type has only 35 turns in the primary. It is essential that both transformers be of the same type, that is, if the 50-turn winding is desired in the antenna stage then the 50-turn winding will have to be used in the detector stage.

The audio system of one stage of 245 has as nearly a perfect linear response curve as is possible to obtain. Curves plotted from RMS voltage inputs and outputs of the 224 detector and the 245 power tube reveal the fact that the power tube will overload sooner than the detector, and assuming that the

operator will not work the 245 beyond the overload point, it is easily seen that the detector will never be worked near the top of the curve.

Official Parts List

Parts from which this receiver was constructed are shown in the list below.

- 1—Silver-Marshall 669 power unit
- 1—Sangamo type E 30 henry output impedance
- 1—Sangamo type F 200 henry plate impedance
- 1—DeJur Amsco .00035 two gang condenser with dial
- 2—Silver-Marshall shielding cans
- 2—Silver-Marshall 132-A coils
- 4—Silver-Marshall 5 prong sockets, No. 512
- 1—Silver-Marshall 4 prong sockets, No. 511
- 1—Electrad antenna type super Tona-trol
- 1—Frost a. c. line switch
- 4—Electrad grid leak mountings
- 1—Durham 1/4 megohm heavy duty resistor
- 1—Durham 1 megohm resistor
- 1—Durham 400 ohm resistor
- 1—Durham 15,000 ohm resistor
- 1—Electrad B 1565 ohm resistor
- 4—Silver-Marshall 275 r. f. chokes
- 1—Sangamo .001 mica condenser
- 1—Potter 2 mfd 400 volt condenser
- 6—Potter 1/2 mfd condenser
- 1—Potter .1 mfd condenser
- 2—Pr. Silver-Marshall sub-panel brackets
- 1—Frost 10 ohm center tapped resistance
- 4—Eby binding posts
- 2—Triad, Cunningham or Arcturus 224 tubes
- 1—Triad, Cunningham or Arcturus 245 tube
- 1—Triad, Cunningham or Arcturus 280 tube
- 1—7 x 21 x 3/16 in. front panel
- 1—10 x 14 x 3/16 in. sub-panel

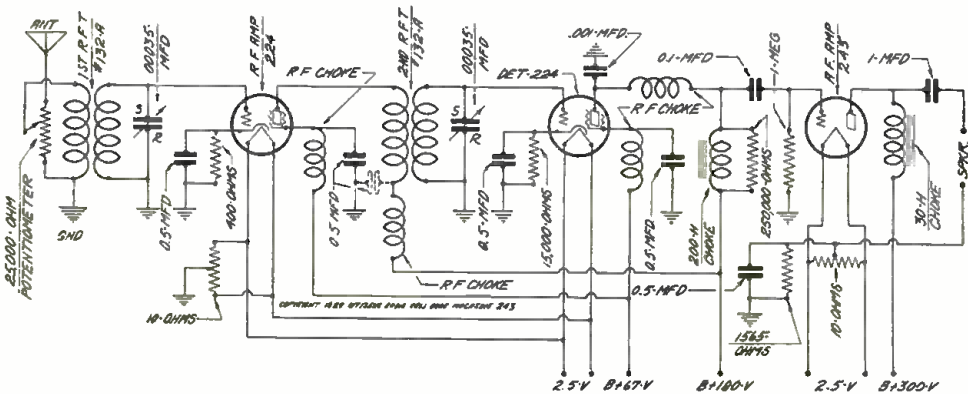

Fig. 4. The receiver may be wired from this schematic drawing

Norden-Hauck Announce New Model Admiralty Super-Ten Radio

Double Tuning Control, Resonance Meter, Push-pull 250 Stage, and Screen Grid Tubes in Receiver

DESIGNED for the custom built trade, Norden-Hauck, Inc., Philadelphia, Pa., have recently announced a new Admiralty model known as the Admiralty Super 10.

The photograph in Fig. 1 gives a top and front view of the chassis which is built up complete with power supply. A front panel view of the receiver is shown in the photograph, Fig. 2. There are two selector dials, one at the left and one at the right for tuning. The meter at the right is a tuning indicator and shows when resonance between the circuits is established. The meter at the left indicates the line voltage. At the extreme left of the panel is a sensitivity control, while at the right of the panel is a volume control. An auxiliary control is placed in the center of the panel at the bottom.

Short Wave Range Too

The receiver is regularly equipped for 200 to 500 meters and 18 to 80 meter range, using removable coil system. Special coils may be furnished on order. The designers guarantee selectivity of one per cent of wavelength on signals of equal intensity.

The set is recommended particularly for private residences and also adaptable for special installation in clubs, apartments, schools, hotels, hospitals, auditoriums, yachts, motor-boats, scientific expeditions.

The chassis is constructed entirely of No. 14 gauge aluminum pierced for mounting the various instruments. The wiring is extra heavy and double insulated, while heavy aluminum and copper shielding is used at all points advisable.

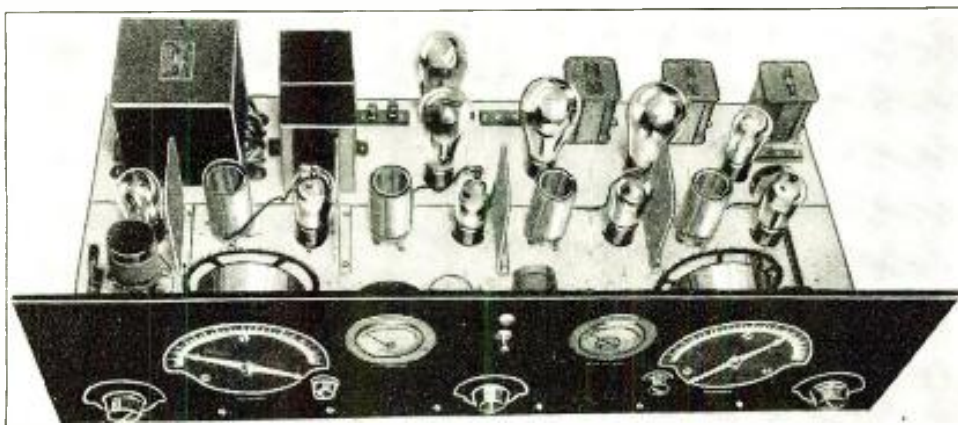

Fig. 1. This photograph shows a top view of the chassis with shields removed

Several microfarads of by-pass condensers are used in the receiver circuit. All are of the self-healing type and trouble proof.

All transformers and coils are wound on natural bakelite tubing with insulated wire and each coil is arranged to eliminate any possible interaction with others. The removable coils have smooth action plug bases.

Jacks are provided in the rear for loud speaker and phonograph connections. The entire installation is operated by the panel switch on the receiver.

Power Detection Used

Four UX-224 screen grid tubes and two UY-227 tubes are used in the r. f. amplifier, one 224 as a power detector, one 227 as a first audio stage and two 250 tubes in push-pull for power amplification. The power supply contains two 281 rectifiers arranged in a full wave circuit.

The current supply in the Admiralty Super 10 has heavy transformers and the filter condensers are self-healing.

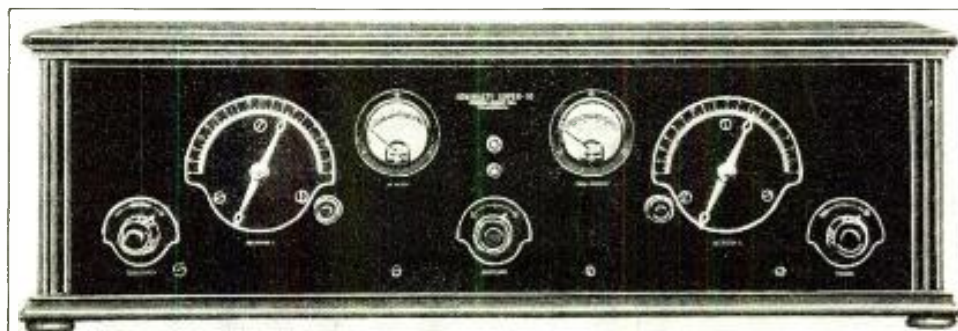

Fig. 2. The front panel of the Admiralty Super 10 is shown in this photograph

The voltage dividing resistors are vitreous enamel and the entire unit is properly fused for full protection of the parts.

Great care has been taken to prevent any possible distortion in the audio amplifier. Parallel plate feed is used so that only voice currents flow in the audio transformer which prevents core saturation.

In keeping with the receiver Norden-Hauck have designed a 10-inch dynamic speaker known as their model N-50. Since the amplifier in the receiver uses two 250 tubes in push-pull requiring an output in excess of 12 watts, it is necessary that the speaker be designed to handle that amount of power without distortion.

Another unusual feature of the new receiver is the arrangement for reception on short waves. This is obtained by a removable coil system. It is only necessary to change two coils to alter the wavelength range. Although the receiver is equipped to operate between 200 and 550 meters, plug-in coils may be used for experimental reception on television work between 18 and 80 meters as desired.

The receiver may be had in a table model of solid mahogany or walnut, or it may be secured as a console model of the same wood. Still another model is the highboy, which is also of mahogany or walnut as desired. Both the console and the highboy models contain the Norden-Hauck 10-inch free edge dynamic speaker referred to previously in the article.

All receivers are given a thorough air test at night by receiving engineers on all classes of reception for sensitivity, selectivity and quality of reproduction.

Changing Electrical Energy Into Sound Is Interesting Step

If Fidelity, Efficiency and Noise Freedom Are Demanded Reproducer Design is Difficult



Fig. 1. Here is a busy corner of the machine shop where presses, lathes, milling machines, grinders, drill and tap presses do the work required to make a dynamic speaker

Like many other modern wonders, only simple materials are used. The materials are metals, paper, leather and bakelite. The best must be used, but there is more than material in a radio speaker. There are brains. The care in design, the excellency and accuracy of construction, the methods of assembly, are the crux of a speaker. Many speakers have excellent raw materials, but the genius back of it, the corps of experts co-operating, planning, and thinking are what make the good speakers the truly fine instruments they are.

Tour of Factory

To illustrate the quality of the speaker, let's take a tour through the Magnavox factory, beginning with the machine shop where can be seen the start of a speaker.

This is where the raw metals, steel, brass, and copper are cut, punched, twisted, turned and ground until they take the forms necessary for a loud speaker.

Presses, lathes, and milling machines, grinders, drill and tap presses do the work. The machines are carefully arranged in order so that the work for one particular part starts from one end



Fig. 2. A corner of the assembly room is shown in this photograph where assembly work is accomplished in two steps. In the right foreground the cone housings, the cones and the movable coils are being assembled

MOST types of energy transformations are difficult, especially if the change is from one type of energy to another. To change heat energy or to change the quality of electricity is not as hard a thing as to change electrical energy to sound energy. To transform water power to electrical power requires some rather intricate machinery. To change coal to mechanical or electrical energy is not simple. Neither is it easy to make intelligible sounds from electrical impulses. This is the function of a loud speaker.

In radio broadcasting and receiving, there are many transformations. Sound waves are converted into electrical waves. The electricity flows through tubes, through coils, through condensers and finally out into the air. In the receiver the reverse process takes place. Electricity is changed to many different forms, and finally becomes once more sound. It is wonderful that such things can be done with electricity.

Electricity to Sound

From electricity to sound is quite a step. When utmost fidelity, efficiency, and freedom from extraneous sounds are demanded, the design of a radio reproducer is a very difficult problem. It is the final link in a complicated and ingenious chain. Every link must be good, the speaker above all, as it is the final link and the only instrument by which the others can be tested and compared.

of a group as raw material and finishes as a complete speaker part. Complicated and ingenious dies blank out the parts. Other presses form them to shape. Lathes face and finish surfaces. Milling machines cut off and square angles. Grinding machines finish to exact size. The work is clamped in jigs, drilled and tapped, and all through the operations are the inspectors, measuring, gauging, and examining.

Punch Press Useful

A punch press is an exceedingly useful machine. It has the accuracy of a microscope, the brains of a man, and the strength of giants. From a flat piece of metal are formed field coil cases, cone housings, speaker bases and all the little intricate parts necessary. A flat piece of iron is put under the press. A heavy die hits it. The piece is cut to shape. Another press pierces the holes. The next machine forces it into shape. Another operation and the part is accurately shaped. A lathe trims the edges. Then drill presses. Holes are threaded. The part is carefully gauged and is ready for the enamel.

In a corner of the shop are automatic lathes. Feeding raw material, cutting, drilling, threading, facing and leaving the finished part in a bin without any attention beyond occasional inspection.

Accuracy is the slogan. The toler-
(Continued on page 125)

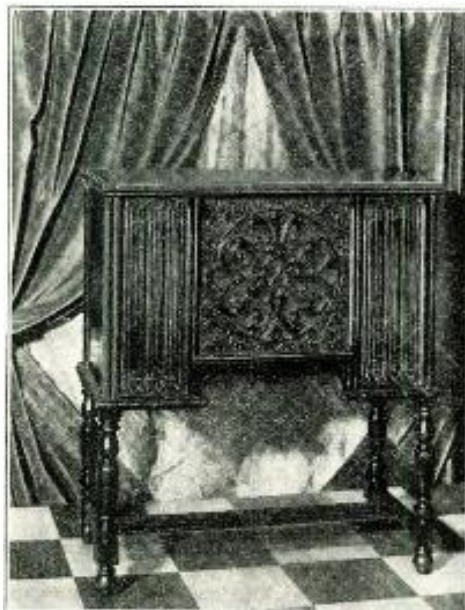

Fig. 3. The finished product is placed in its console. This particular model is known as Campanile and is Magnavox' deluxe model



PRACTICAL TELEVISION



Laboratory Television Amplifier

ACCORDING to the engineering staff of the International Resistance Co. although present-day audio amplifiers perform well enough for the requirements of the average broadcast listener-in, there are times and places calling for more precise devices. With the advent of television promised at an early date, a far more accurate amplifier will be necessary than we now have available in everyday practice, since the eye is harder to fool than the ear. Hence the following brief outline of a precision resistance-coupled amplifier particularly intended for a laboratory or television application.

Free From Feedback

The audio amplifier we are now dealing with is positively free from feedback troubles, microphonic howls, distortion and so on. It may be employed in conjunction with a radio, a phonograph or a television pickup. It provides a gain of approximately 55 decibels, and an undistorted power output of 1½ watts over a frequency band of 30 to 10,000 cycles.

As will be noted in the accompanying Fig. 1, the amplifier in question employs four tubes, namely, a UX-240 (high Mu), a UX-201-A, a UX-112-A, and a UX-250, wired in cascade or successive stages. In the laboratory the amplifier can be mounted in bread-board form, with sponge-rubber feet attached at the corners to minimize vibration. At the edges of the board, binding post strips may be arranged for input and output posts, with a long binding post strip at the rear to accommodate the supply voltages. Insulated filament wires are placed underneath the mounting board. The first three tubes have their filaments heated by a 6-volt stor-

age battery, while a 7½-volt winding on the power transformer supplies the filament current for the 250 power tube.

Only the highest grade resistors should be employed. Noise, excessive resistance change with load, and marked resistance fluctuations with varying weather conditions, cannot be tolerated in a precision amplifier. The use of metallized resistors throughout is therefore recommended, of proper resistance value and current-handling capacity for each function.

pling resistance between the plate of the 240 to the grid of the 201-A has a value of .75 megohm and a rating of 1 watt. The series resistor between the grid of the 201-A and the negative 100 volt bias tap is a .5 megohm with a rating of 1 watt. Filament current is handled by the ¾ ampere.

In the plate circuit of the 201-A the plate resistor is 75,000 ohms with a 2 watt rating, the coupling resistor is a .25 megohm, 1 watt, while the series grid resistor is a .25 megohm, 1 watt.

The plate circuit of the 112-A has a resistor with a value of 45,000 ohms with a rating of 5 watts, while the coupling resistor to the grid of the 250 tube is a .25 megohm, 1 watt, and the series resistor in that grid circuit is of the same value.

The filter condensers used across the input and output of the rectifier system are 4 mfd with a voltage rating of 1300 volts.

The filter condenser across the center section of the filter choke is a 2 mfd with the same 1300 volt rating. The filter choke used in the experimental set-up was an Amerchoke type 557. That portion of the resistance network between the ground terminal and minus 240 is a 5000 ohm, 100 watt, rating. This same value of resistance and current rating is used in the upper section of the resistance network illustrated in Fig. 2. The center section of the resistance network is a 50,000 ohm resistance with 50 watts capacity.

Reproduction Faithful

The reproduction of recorded and broadcast music or speech, using this amplifier, is truly remarkable in conjunction with one or more high-grade loud-speakers. The balance struck between high and low frequencies is immediately apparent in crisp, under-

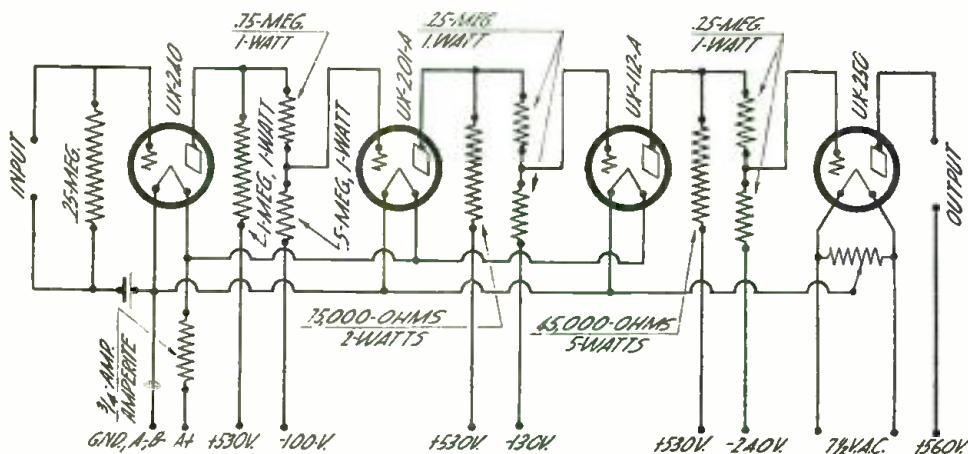

Fig. 1. Constants of the laboratory television amplifier described here is shown in the above schematic

The power supply illustrated in Fig. 2 delivers 800 volts at 75 milliamperes for the B and C requirements of the amplifier. The power transformer is provided with three center-tapped secondaries, namely, two of 7½ volts and one of 1,500 volts. A pair of UX-281 rectifiers, low-resistance chokes, three high-voltage filter condensers and a voltage-divider network, complete the power supply. For the preliminary setup, approximate voltages are indicated in Fig. 2. Readjustments may be made to take care of the slight differences in tubes and other equipment.

Circuit Values

The input resistor illustrated in the schematic diagram, Fig. 1, has a value of .25 megohm. The plate resistor used in the plate circuit of the 240 tube has a value of 1 megohm with a current dissipating capacity of 1 watt. The cou-

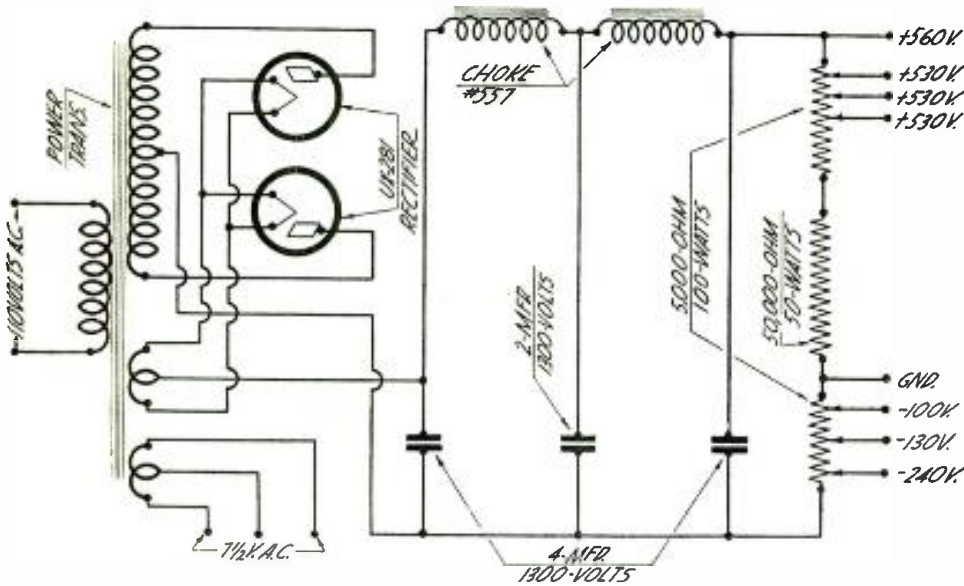

Fig. 2. The power supply is wired in accordance with this diagram

standable speech and sparkling music, together with deep, mellow and rich musical rendition of accompaniments. In connection with laboratory studies and television, this amplifier provides the desired straight line amplification for maximum fidelity of reproduction, as contrasted with the usual pleasing distortion or acoustical compromise of the average broadcast amplifier and loud-speaker combination.

Jenkins Announces Scanner

AN ingenious combination of scanning drum and selector shutter has just been demonstrated by the Jenkins Television Corporation engineers. The new arrangement, which takes the place of the Jenkins scanning drum with light-conducting rods and four-plate neon glow lamp, is far simpler, cheaper and more efficient in matters of detail and illumination. In fact, not only are the silhouette or Jenkins radiomovies received with crisp, sharp, sparkling back-and-pink definition, but half-tone pictures are also handled by the same scanning mechanism with excellent results. With experimental transmissions of a closeup film of a girl by the Jenkins W2XCR station, the new scanning mechanism can reproduce the

animated pictures with sufficient detail so that the features are readily identified by the lookers-in. There is also a considerable increase in illumination, due to the use of a standard neon lamp with large plates, instead of the former

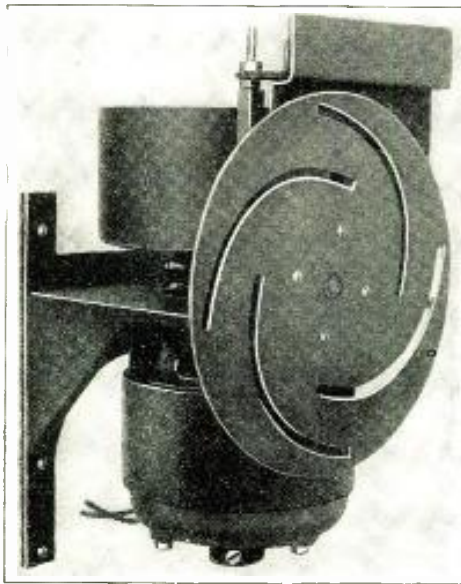

Fig. 2. The mechanics of the Jenkins Television which weaves television signals into animated pictures on the home screen. This simplified arrangement comprises the scanning drum at the top, containing the vertically mounted neon glow lamp; a selector shutter in front; and the synchronous motor which maintains a driving speed in step with the transmitter. This compact assembly fits into a cabinet with recessed opening or shadow box containing the magnifying lens for enlarging the television images



Fig. 1. Television transmitting station of the Jenkins Television Corporation in Jersey City, N. J. The 5-kilowatt transmitter is shown at right; operator's table and pick-up amplifiers in center; monitoring television scanner at left

small plates of the four-plate neon lamp. With the elimination of the revolving contact switch gear for flashing the multiple plates in proper turn, the present mechanism presents a minimum of noise in operation.

The main point about this new Jenkins development, however, is that a scanner can be produced at a relatively

low cost. With the elimination of the elaborate scanning drum with light-conducting rods and multiple-plate neon lamp, the equipment is reduced to simplest and most economical terms, yet the performance is remarkably improved. The use of a novel selector shutter in combination with a small scanning drum, so that the drum rotates four times in flashing each 48-line picture, results in retaining the compact dimensions of the Jenkins technique.

Cages for Televisionists

FOR good and sufficient reasons, television workers are being placed in wire cages, these days. The reasons are purely electrical, and not psychological. In brief, the men who handle the delicate film pick-up mechanism which converts film images into radiomovie signals, for transmission over Station W2XCR, the Jenkins television transmitter in Jersey City, N. J., are obliged to work in grounded copper mesh cages which keep out all stray radio signals or inductive disturbances.

The pick-up apparatus and amplifier for radiomovies are exceptionally delicate and susceptible to extraneous interference. Unusual precautions must be taken by way of thorough shielding against stray radio signals as well as inductive disturbances within the laboratory building and even from outside sources. Aside from the large copper mesh cage, which serves as a general shielding of all the apparatus, there are individual copper covers and partitions for the various pieces of sensitive equipment, while the critical conductors are copper sheathed. Only in this manner, we are assured, can satisfactory television signals be broadcast, free from troublesome streaks and specks due to interference.

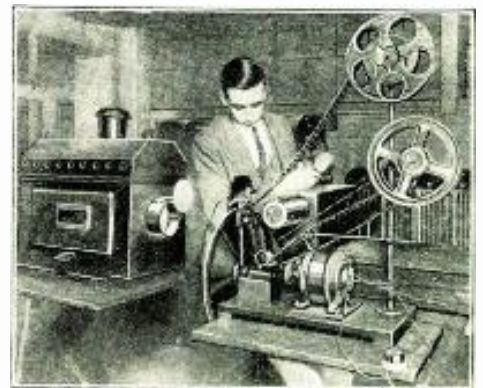

Fig. 3. The present Jenkins television studio is really an elaborate film pick-up apparatus shown in this view. The pictures are recorded on motion picture film which is placed in this machine. As each picture passes through the mechanism, it is scanned by a pencil of light and casts a shadow on a photoelectric or light-sensitive cell. The cell translates light values into electrical values, which in turn are impressed on the outgoing radio wave

The ABC of Radio

History of Dial Marking

RADIO dials were first marked in numbers only. Sometimes dials used the 0-100 system. At other times the dials were graduated in geometric degrees. Both of these methods served only as reference points. They both made it necessary for the operator to fish for a new station. With the improvement of receiver design, it became practical to calibrate the dials. These dials were marked sometimes in wavelengths, sometimes in kilocycles, and occasionally in both. A few manufacturers went so far as to include not only kilocycles and wavelengths, but also added a reference scale. The use of this multiple system was often as confusing as it was helpful.

The Federal Radio Commission and scientific organizations have adopted the use of kilocycles only. No cross-reference is being made to wavelengths. The broadcast band has been laid out on the basis of a 10-kilocycle separation between stations. The band extends from 550 to 1500 kilocycles.

This uniform spacing makes a kilocycle dial a convenient reference dial as well. The tendency in new receiver design is decidedly in favor of marking dials with but a single scale, that of kilocycles.

Mystery of Skip Distance

TO many, uninitiated to the mystery and romance of radio, the phenomenon known as "skip distance" proves to be the most puzzling, according to J. E. Smith, President of the National Radio Institute of Washington, D. C.

The layman, unfamiliar with the characteristics of radio transmitting, might reasonably assume that the closer one happens to be to a broadcast station the stronger would be the signals received. More than likely, that is true in the case of the ordinary long-wave station.

However, in the case of a short-wave transmitter, "skip distance" enters into the situation and reverses things considerably. For instance, it is possible that a short-wave transmitter in New York, operating on much less power

than is ordinarily used by the long-wave stations, may be picked up in Australia with such volume as to be heard all over the room. At the same time, these same signals may be picked up with great difficulty or, perhaps not picked up at all, by receivers located less than 500 miles from the transmitter. The signals seem to skip over certain areas entirely only to reappear at much greater distances. This, in short, explained Mr. Smith, is the effect known as "skip distance." It presents many problems in short wave transmission, especially between land stations and planes in flight.

Bettering Tone Quality

WHILE there is nothing new in shunting the usual transformer secondary with high resistance, it is surprising how little this simple method of improving tone quality is employed today. Nevertheless, there is hardly a transformer that will not be improved somewhat by the use of resistance across its secondary. This is especially marked in the case of the cheaper transformers with their pronounced frequency response peaks which are effectively flattened by introducing resistance.

Small fixed condensers are sometimes employed across the primary of transformers for the purpose of cutting off higher frequencies and producing a more pleasing tonal quality. Such practice is sometimes the cause of certain resonant effects in a circuit, hence should be applied with due caution. It is better practice to employ the proper resistance across the secondary of the second transformer, as well. This reduces the volume slightly, but improves the tone quality.

Just what resistance to employ is difficult to state, since it is dependent on so many variables. The range may be anywhere from 50,000 ohms to 200,000 ohms, in some cases even higher, to obtain the proper tone quality without sacrificing volume. Hence a variable resistor, such as the Clarostat with its resistance range or from practically zero to 5 megohms, provides the precise resistance for any arrangement.

Likes Junior Set

CLARENCE SPARROW, 8623 — 109th St., Richmond Hill, N. Y., tells his experience with the Junior set which appeared in these columns:

"In your summer edition, pages 47 and 48, you gave the Junior set. I made this up last Saturday afternoon and it was sure a surprise. Pittsburgh, Baltimore, Rochester, Atlantic City came in with plenty of volume and as clear as a bell. WABC gave trouble, so put in midget condenser and rheostat to control the juice. It works 50 per cent better. Could not this set be improved with another tube and condenser to control distance?"

"Made a Bodine twin-eight which you published last year and have been using it all along, but this last set of yours has remarkable tone and would give up the other if I could only get further distance, like the Bodine. I must compliment you on this four tuber and all who have heard it say it is a wonder."

Electrical Spiders

ELECTRICAL spiders quite as ingenious and capable as the usual spiders, are now employed by the radio industry in spinning many miles of resistance filament consumed each month both here and abroad. These spiders—if potential license be permitted—are the machines employed in spinning a hair-like glass thread which is subsequently coated with a deposit to form metallized filament. Mounted either in a glass tube or a ceramic tube, with metal caps, the final product is known as a metallized resistor or a metallized powerohm.

In supplying the steadily increasing demand for metallized resistors, including power requirements as well as receiving circuit requirements proper, something like 2,500,000 feet, or about 470 miles, of metallized filament will be produced during 1929. The entire supply for the world at large is made by a battery of electric spiders in one of the plants of the International Resistance Company of Philadelphia, Pa. Each electrical spider takes a special glass rod of about $\frac{3}{8}$ inch diameter, presses one end against an electrically-

(Continued on page 128)

Recording Equipment for Talkies Uses Many Radio Principles

*Both Film and Disc Recording Undergoing Constant Changes to
Find the Perfect Method*

PART II

By J. E. SMITH*

(The first part of this article on Talkies was published in the September, 1929, issue of this magazine. In this installment Mr. Smith brings the subject up to date.—Editor.)

1. PHONOFILM.

PHONOFILM was developed by Dr. Lee De Forest, to whom belongs the credit of making sound pictures a commercial possibility. Dr. De Forest demonstrated his Phonofilm in many theatres in 1923 and proved the commercial practicality of sound pictures.

However, it was not until 1926 the Vitaphone was demonstrated to the public, Fox-Case Movietone in 1927, and Western Electric Movietone in 1928. The Phonofilm is a photographic system which records a sound track of constant width but of varying density, and a Phonofilm sound track is similar to a Movietone track.

5. PHOTOTONE.

Phototone is a system in which the sound is recorded on discs and in this particular it is similar to the Vitaphone system. There is one major difference, however, namely, that Vitaphone records are recorded and reproduced at a turntable speed of 33 revolutions per minute, whereas in the Phototone system records are recorded and reproduced at 78 revolutions per minute,

*President, National Radio Institute, Washington, D. C.

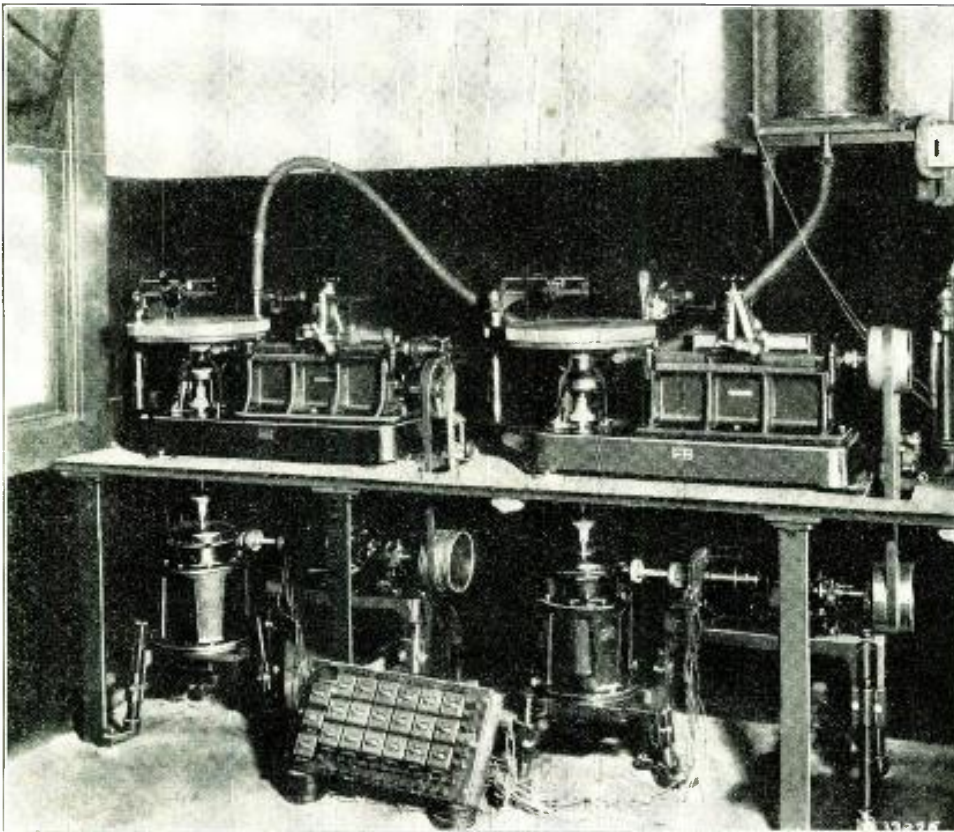

Photo Bell Telephone Laboratories

Fig. 1. Here is shown one of the Vitaphone disc recording machines

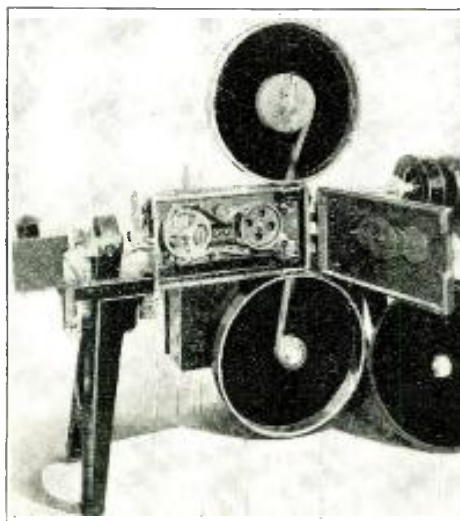

Photo Bell Telephone Laboratories

Fig. 2. This machine records sound on film in contrast to the method used in Fig. 1

which is the standard speed at which ordinary phonograph records are operated.

6. MADALATONE.

Madalatone is a photographic recording system and it differs from other photographic methods in that the latter have all produced a sound track along the edge of the film, which is either of varying density and constant width or of varying width and constant density. Also, in other systems the sound has been picked off the film by passing a sharply focussed beam of light of high-intrinsic brilliancy through the

sound track as it is passed through the projector during the course of reproduction, and due to the varying density, or the varying width of the sound track, the light coming out the other side of the film varies in accordance with the variations in the sound track. This variable light is picked up by a photo-electric cell, which, true to its characteristics, changes the light variations into electrical variations. The latter are amplified and applied to the loud-speakers, which change the electrical variations back into sound again. Now in the Madalatone system the sound is engraved on the film and is picked off the film by means of a reproducing device which is set into mechanical vibration. This vibration is changed into electrical energy, amplified, and then transformed back into sound again through the medium of the



Photo Bell Telephone Laboratories

Fig. 3. Vitaphone play-back equipment is shown above

output horns. No photo-electric cell is required in the Madalato system.

Vitaphone Recording

A. STUDIO.

The studio in which sound pictures are recorded must be either sound-proof or acoustically treated, so that sounds from outside do not penetrate, to be picked up by the microphones within the studio and thus interfere with the sound record being made. The interior of a sound-recording studio is acoustically treated so that it will not be too reverberant and thus effect all sorts of reverberation, echo and extraneous sounds.

Sound energy once produced in a studio will continue to exist until it is absorbed and this rate of absorption will be very low if the studio is surrounded by hard-reflecting surfaces. If not acoustically treated, it is possible that the rate of absorption within a studio would be so low that a word spoken in a usual tone of voice would be audible for several seconds afterwards, which would mean that the dozen or so syllables following the word in question would blend into the decaying sound of the word and render understanding extremely difficult.

On the other hand, a sound-recording studio should not be too dead. It should have some life to it. Thus the life of a studio is a function of the walls surrounding the studio, the ceiling, the floor, and the persons and articles within the studio. When a sound shot is being made, it is obviously desirable to pick up only the sound pertaining to the action being filmed and all extraneous noises only aid in bringing up the ground noise and are, therefore, a detriment to high-grade recording.

In making sound pictures, a motion-picture camera is used to record the action and microphones are used to

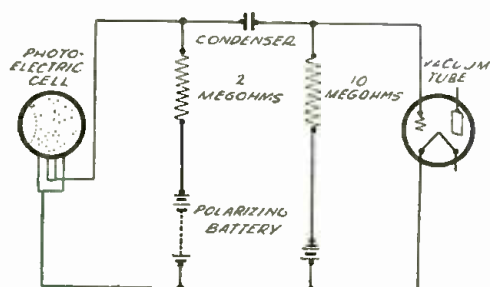

Fig. 4. Schematically this diagram shows the photo-electric circuit

pick up the sounds to be recorded. Every possible precaution is taken to keep the noise from the camera and its driving motor from getting into the microphones. In Vitaphone recording, the camera and cameraman are placed in a sound-proof booth with a window in the front through which the picture is taken.

There is a junction box in the side of the studio wall which will allow for the plugging-in of six condenser-type microphones. These condenser-microphones consist of a condenser-transmitter unit, which is attached directly to the condenser-transmitter amplifier. The latter is enclosed in a shielded tubular case and provides one stage of amplification with an output transformer having a 50-ohm secondary winding.

These condenser-microphones are usu-

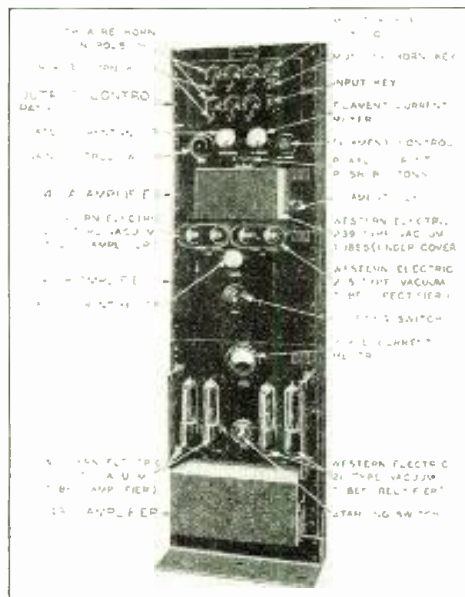

Photo Bell Telephone Laboratories

Fig. 5. One of the standard amplifier racks is illustrated in the above photograph

ally suspended from the top of the studio and are equipped with 75 feet of cable, on the far end of which there is a plug which is inserted into the receptacle in the junction box. There are five leads in the condenser-microphone cable, which are properly shielded and they carry the following energy: +6 and -200; -6; +200; and two leads from the 50-ohm output of the condenser-transmitter amplifier, which are connected through to one of the input positions on a six-position mixing panel.

B. MIXING PANEL.

The pick-up man then places the microphones in their proper position on the set, and the output energy of all the microphones in use is brought to a mixing panel. There the monitor man sits, in a sound-proof enclosure overlooking the activities on the stage. There is a monitor horn at one end of

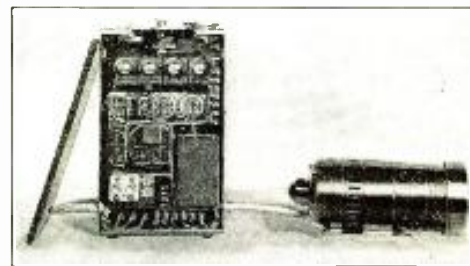

Photo Bell Telephone Laboratories

Fig. 6. At the right is a generator for the control panel, the rear of which is shown at the left

the monitor room, by means of which the monitor man gets a true perception of the quality of the sounds being picked up and whether there is a proper balance between the different microphones or not.

At the mixer position there is a separate control on each individual microphone in use to obtain a good balance, and there is a master control on the total output from the mixer for obtaining the proper level. This level can be read on a volume-indicator meter on the master control panel at the mixer position.

C. AMPLIFIER ROOM.

The output of the mixer is connected through to the amplifier room where it is first applied to the input of a W. E. 8-C amplifier, which is a three-stage transformer-impedance coupled unit having a gain of about 81 TU.

The 500-ohm output of the W. E. 8-C amplifier is connected to what is termed a bridging network. A volume-indicator meter, with an extension to the mixer position, is connected across the bridging network. By means of this meter it is possible to read the sound level on the net-work at all times, and by means of the meter extension at the monitor man's position, the latter is able to read the level there at all times. It is by this means that the sound to be recorded is kept at a predetermined level at the recorder.

A number of amplifiers are connected to the net-work in parallel. These amplifiers are called bridging amplifiers and are so designed that five

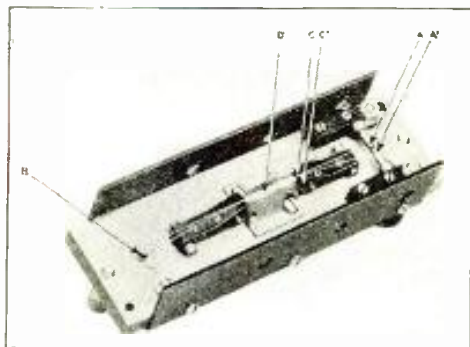

Photo Bell Telephone Laboratories

Fig. 7. The heart of the talkies is in the light valve pictured above

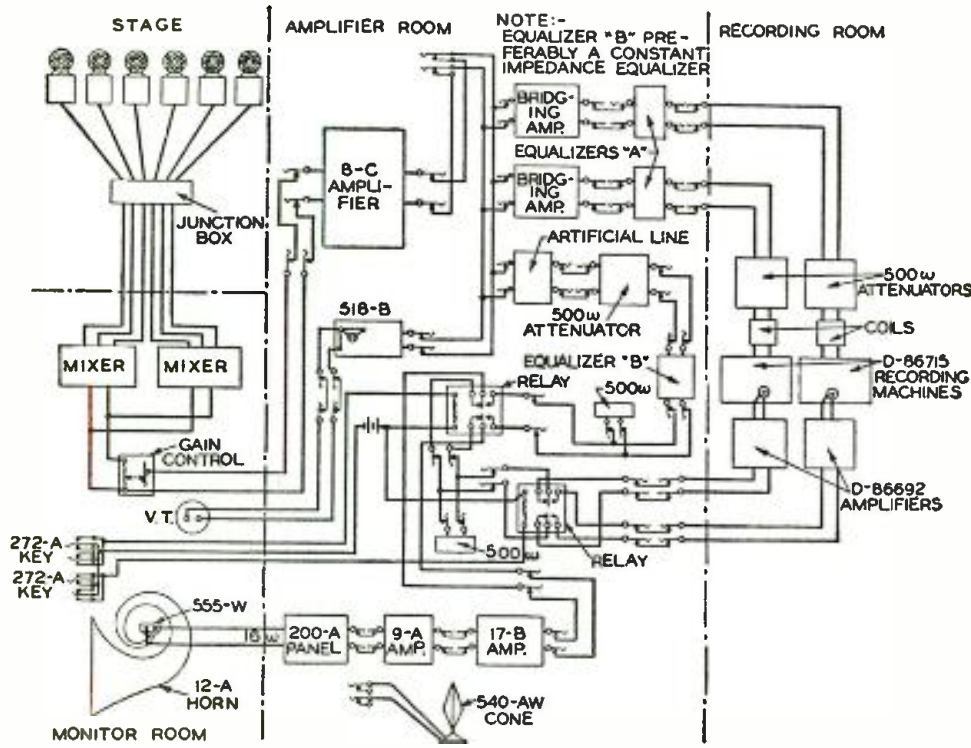

Fig. 8. A typical studio operating arrangement is set forth in the illustration above

of them can be bridged across a 500-ohm circuit without trouble. Each one of these bridging amplifiers feeds a disc recorder. If there are two disc recorders in use, the two bridging amplifiers are required.

D. DISC RECORDERS.

The 500-ohm output of the bridging amplifier is connected to a 20 TU attenuator, which is variable in 2 TU steps, and which has an impedance of 500 ohms, in and out. This attenuator is of use where it is desirable to record with a number of disc machines and

have the level different on each one.

The output from the attenuator is carried through to the recorder control box where it passes through a double-pole double-throw switch, the latter being used to either terminate the line from the bridging amplifier output in the 500-ohm signal coil on the recorder or in a 500-ohm resistor, depending upon which way the switch is thrown. There is another switch and a rheostat on the recorder control box which is used to control the current through the recorder field coil winding.

A disc recording machine is really a

high-grade lathe. There is a turntable, which is driven at a constant speed of 33 revolutions per minute and all fluctuations in speed are eliminated from the turntable by means of an oil damper in series with the driving mechanism, which damps out mechanical surges.

The recorder or cutter is mounted over the turntable and is given a lateral motion so that it cuts a spiral groove in the wax disc which is placed on the turntable. The lateral movement is usually such that the "pitch" of the grooves on the disc are about 11 millimeters, or in other words, there are about 92 grooves per inch.

The cutting stylus, which is made of sapphire, cuts a groove in the wax, which is between 6 and 7 millimeters wide and between 2 and 3 millimeters in depth. When sound currents are passed through the signal coil on the cutter, the cutting stylus is given a lateral motion and, therefore, cuts a side-to-side track in the course of making a sound record.

E. SYNCHRONIZATION.

Synchronization is accomplished by means of an electrical interlock system. The motors which drive the camera mechanism and the ones that drive the disc recorders have their stator windings all connected to the same 220-volt a. c. supply. The rotors of all these motors are connected in parallel to the rotor windings of an a. c. motor, which is a part of the distributor. The distributor consists of a d. c. control box. This d. c. motor is connected, by means of a shaft, to an a. c. motor which forms the rest of the distributor. All of the

(Continued on page 123)

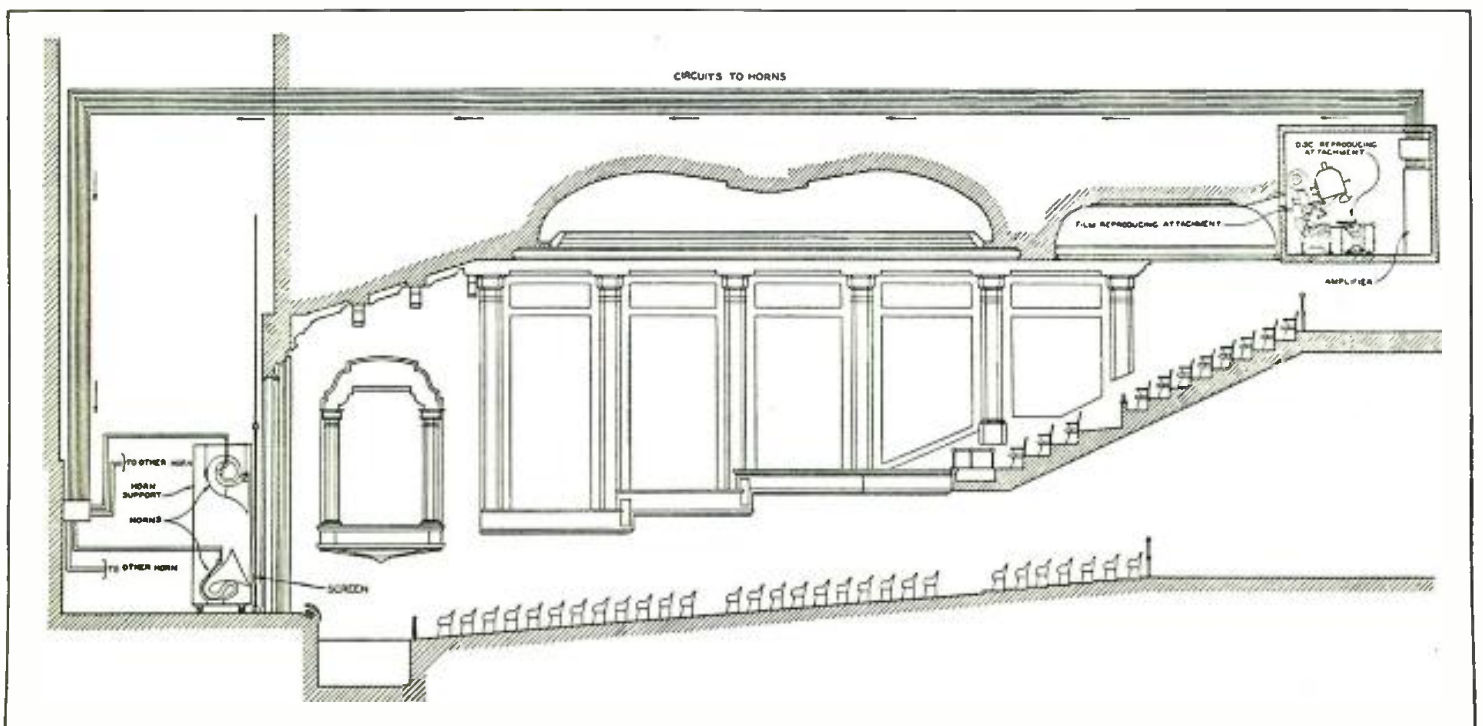

Fig. 9. Movie patrons seldom think of the mechanics involved in the talkies so this general theater layout may be of some interest

Radio Telephone Equipment Is Used for Railway Communication

Engine Man in Locomotive Cab May Talk to Conductor in Caboose; No Radio Knowledge Needed

THE development of radio equipment for front and rear-end telephone service on freight trains has been proceeding for some time under the direction of the General Electric Co. in cooperation with Committee No. 12, telegraph and telephone section of the American Railway Association, and the New York Central Railroad. The initial tests were made with a locomotive and caboose lent by the New York Central Railroad located in the Schenectady works of the General Electric Company.

After determining in a general way what were the requirements for handling this kind of work, especially designed sets were placed on a standard caboose and a type L2 locomotive. The first run was made on July 20, 1927, between Selkirk and Utica. This trip



Photo courtesy General Electric Co.
Fig. 1. New York Central locomotive 2724 showing antenna for radio equipment mounted on tender

clearly showed the value of the apparatus. A train of 124 cars was used and frequent telephone messages with regard to handling the train were communicated between the front and rear ends.

After a further period of tests under operating conditions on the main line of the New York Central, further changes were made in the equipment. The resulting apparatus described here has demonstrated its particular adaptability for use on moving trains. Application does not involve any new principles and the only problems to be solved have been those connected with mechanical design and mounting of apparatus to adapt it to railroad service.

No Radio Knowledge Needed

This radio equipment is designed to provide telephone communication between the engine and caboose. Two-way conversation can be carried on between the man in the caboose and those in the engine and the design of the apparatus has been so simplified that no knowledge of radio is required by those using the equipment.

Mechanical construction of the apparatus enables it to withstand successfully the severe operating conditions encountered in railroad service. Both the locomotive and caboose installations

are arranged with spring suspension wherever needed in order to absorb shocks and to prevent damaging the apparatus. In addition the locomotive installation is made weather-proof so that the apparatus may be installed on the deck of the tender.

Normal equipment installed in the locomotive end consists of the transmitter, receiver unit, power unit, antenna, control unit, microphone, loud speaker and the turbine driven generator.

The first three items are installed on the tender tank; the next three units are installed in the cab of the locomotive while the turbine driven generator is installed in the usual manner on the locomotive proper.

The units installed in the caboose are the transmitter-receiver unit, power unit, antenna, control unit, microphone, loud speaker, 32 volt storage battery, battery

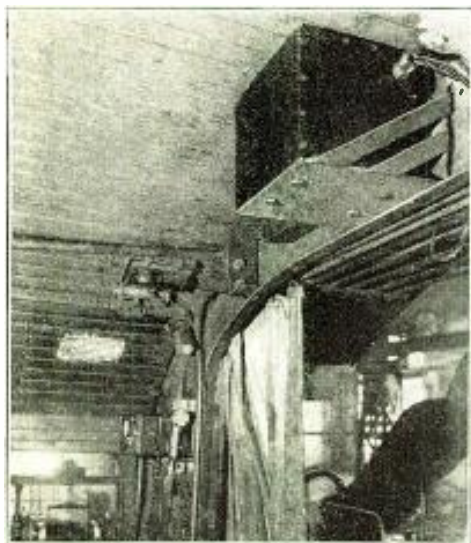

Photo courtesy General Electric Co.
Fig. 2. The control unit of the transmitter and loud speaker is shown installed in a locomotive cab

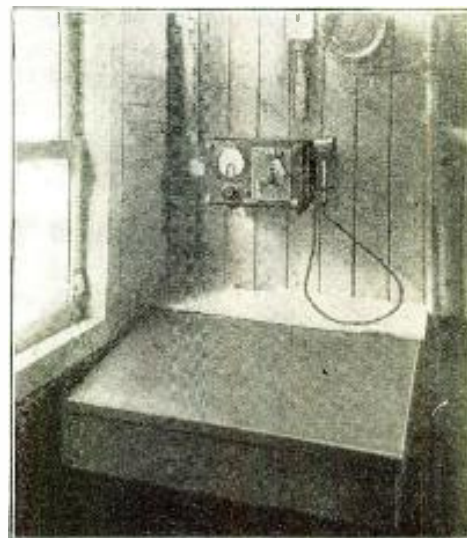

Photo courtesy General Electric Co.
Fig. 3. This installation of the control unit is placed in the caboose of the train



Photo courtesy General Electric Co.

Fig. 4. The railing around the top of the tender contains the antenna for the transmitting system while the radio equipment itself is housed in the two metal cases shown on top of the tender

charging panel and axle driven battery charging generator. The last three items of this list are of the standard train lighting type and are installed on the caboose in the manner similar to the usual coach installation except that the storage batteries may be installed inside the caboose under some of the benches.

50 Watt Rating

The normal rating of the radio transmitter is 50 watts, which is the power delivered to the antenna by the transmitter. The radio transmitter and the radio receiver are each designed to operate on any one frequency within the band from 2,300 to 2,750 kilocycles (130 to 109 meters). This frequency band is one of those at present assigned for mobile radio communication. The apparatus is so arranged that suitable adjustments for any one operating frequency within this band may be conveniently made on the transmitter and receiver. If new rulings by the Federal Radio Commission should require operation on frequencies slightly above or below those specified, the apparatus can be designed for service with the new frequency assignment. The present 2,300 to 2,750 kilocycle band has been selected for several reasons which make it particularly satisfactory for train communication.

The type of signal provided by this equipment is known as the simplex radio telephony. With this system a small push button mounted on the

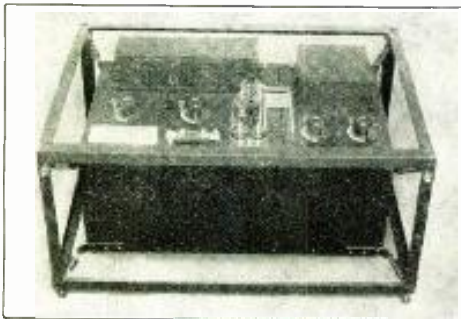

Photo courtesy General Electric Co.

Fig. 5. Mounted on springs at the four corners the Simplex train communication equipment transmitter-receiver is pictured above

microphone is pressed when anyone desires to talk to the other installation. When the push button is released the local apparatus is automatically connected for receiving conditions. By means of this arrangement the radio transmitter is in operation only during the time the push-button is depressed for talking. The radio receiver is, however, maintained in a receiving or stand-by condition at all times so that it is always prepared for any incoming calls which may be put through from the other end of the train. Simplex telephone equipment of this type permits the maximum number of channels to be obtained in the given frequency band, minimizes interference, reduces the power drain required and permits the apparatus itself to be designed for maximum simplicity.

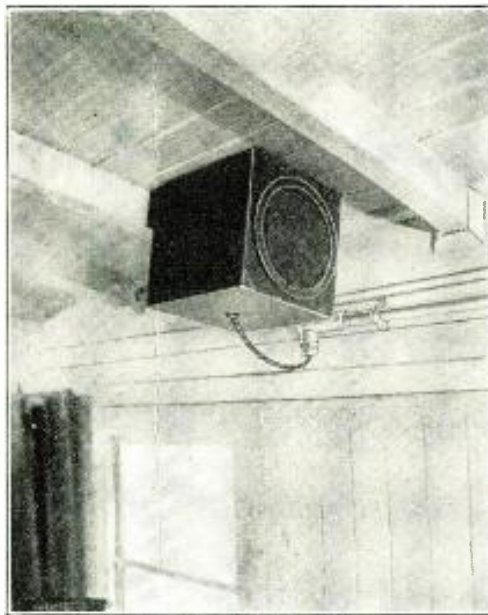

Photo courtesy General Electric Co.

Fig. 6. The speaker installation as made in the caboose is shown here being attached to the ceiling of the car

Tubes and Functions

The radio transmitter uses four vacuum tubes as follows: one PR11A as a master oscillator, one PR11A as a radio power amplifier, one PR11A as the modulator and one PJ8 as the speech amplifier and audio oscillator.

The radio receiver uses the following tubes: one PJ8 as a radio amplifier, one PJ8 as detector and two PJ8's as audio amplifiers.

Power supply for the equipment on the locomotive end is obtained from a turbine driven generator. At the caboose end power is obtained from a 32-volt storage battery, which in turn is charged by the axle driven generator. The equipment at each end draws a current of approximately 32 amperes at 32 volts while transmitting, and a current of approximately 5 amperes at 32 volts while receiving.

Fig. 1 shows a New York Central

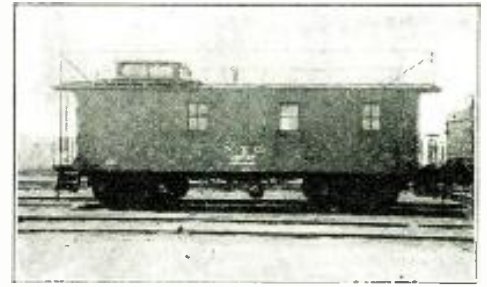

Photo courtesy General Electric Co.

Fig. 7. This photograph illustrates the antenna and axle driven generator for the train communication installation on the New York Central caboose

locomotive No. 2724 equipped for radio. The radio equipped caboose is shown in Fig. 7. The antenna may be plainly seen in this view of the caboose. The belt driven generator used to charge the storage battery is mounted under the caboose. This may also be seen.

The apparatus mounted in the locomotive cab is shown in Fig. 2. The control unit is mounted back of the engine man's seat and is provided with a clamping mechanism for the microphone. A small meter on the control unit indicates the current flowing in the transmitting antenna and serves as a check on the correct operation of the transmitting equipment. The microphone is a special anti-noise type so designed that the majority of the engine noises, noises due to running conditions are not picked up by the microphone and transmitted. By speaking with the lips close to the microphone good quality of speech may be obtained with a complete elimination of extraneous noises. The loud speaker is mounted on the top center section of the cab room and is so arranged that the opening for the sound is directly towards the engine. It is strongly built and produces a volume of sound sufficient to overcome the noises in the cab. It may also be seen in Fig. 2.

The photograph in Fig. 8 shows the engine man using the equipment in the cab. When the microphone is removed from the control unit the necessary circuits are closed to start automatically

(Continued on page 124)



Photo courtesy General Electric Co.

Fig. 8. The engine man is here shown using the microphone of the radio equipment in the cab of a locomotive

Improved Leutz "Seven Seas" Console Has Phonograph Combination

Electrical Phonograph Feature Increases Utility of Well Known Custom Built Radio Set

DESCRIBED originally in our September, 1929, issue, the Leutz "Seven Seas" console has been further refined and is now being offered with built-in electric phonograph. A few lines regarding the new Seven Seas console may be in order at this time.

Speaking in general terms, the Leutz "Seven Seas" console is a refined form of screen-grid radio-frequency receiver. It employs three stages of tuned r. f. using screen-grid tubes, a first audio, and a push-pull audio using two 250 power tubes. The output is fed to a twelve-inch dynamic speaker, and there is sufficient power available to operate several external dynamic speakers if desired.

Screen Grid Possibilities

Although much is being said these days about screen-grid circuits, it is well to note that the potentialities of the screen-grid r. f. amplifier are far from realized in many production receivers, due to insufficient shielding and other shortcomings in design and construction. In the case of the "Seven Seas" console, the shielding is of the most advanced and thorough kind. Since space is not at a premium in this set, as contrasted with the cramped chassis of the usual broadcast receiver, the shielding is arranged in the form of individual compartments for each stage, and with more than ample spacing, so that the r. f. losses are reduced to an absolute and negligible minimum. It is well to recall that C. R. Leutz, the designer of the present set, introduced the first shielded set for broadcasting back in

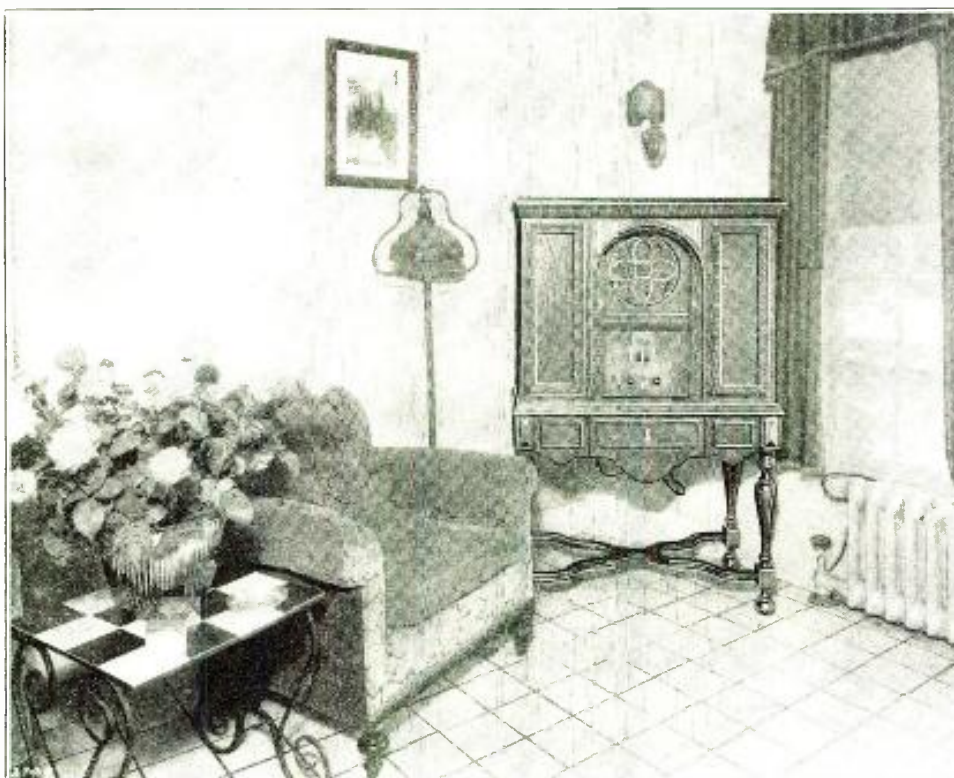

Fig. 1. The photograph here shows the latest model made by Leutz. The dynamic speaker is at the top, the receiver at the bottom of the console. The phonograph combination is in the lower center drawer and may be seen opened in Fig. 2

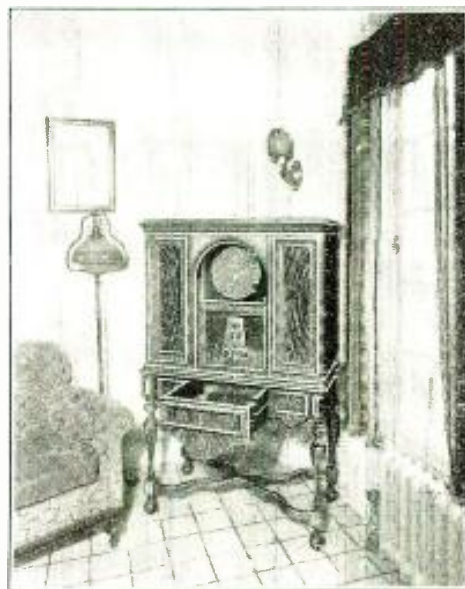

Fig. 2. The Improved Leutz model described in the accompanying article is shown photographically above. The center drawer contains the electric phonograph combination

1921, and has always been an advocate of good shielding. In addition to the tubes and inductances, the gang condensers, mounted on the front of the main container, are entirely shielded, with each stator (or grid) shielded from the next stator. This permits operating the r. f. stages at high efficiency. In fact, the sensitivity of the "Seven Seas" is such that, using an aerial only a few feet long, it is possible to tune in signals from distances of 1,000 to 1,500 miles, with good loud-speaker volume, during average summer weather. Reports

of daylight reception of 500 to 750 miles have frequently been received by the builder.

Retains the 250 Tube

Despite the high gain in the screen-grid r. f. amplifier, the first audio stage has not been dispensed with as in other high-grade screen-grid circuits of today. Mr. Leutz is a firm believer in the first audio stage, particularly when striving for the enormous volume obtainable from present-day power tubes. Furthermore, instead of using the popular 245 power tube, he has insisted on the 250 or largest power tube, so that the "Seven Seas" console, as in the case of a powerful, high-priced car, is never used to its fullest capacity. The result is an excellent clarity and easy flow of loud-speaker rendition, which is free from the slightest trace of strain or overloading.

A novel form of coupling is employed between the detector and the first

(Continued on page 130)

Digest of Science



Plotting Street Car Noises

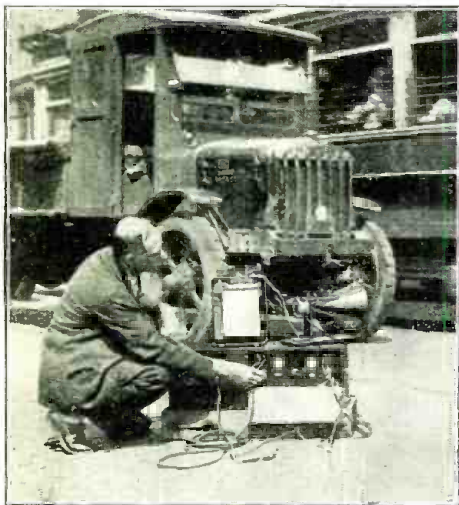

P. & A. Photo

Using a special noise recording instrument and working on a Chicago street, Prof. J. E. Tuthill, of the University of Illinois, is seeking to learn what makes the noise a street car produces traveling along city streets. He hopes to find a way of eliminating the noise.

New Beam Wireless

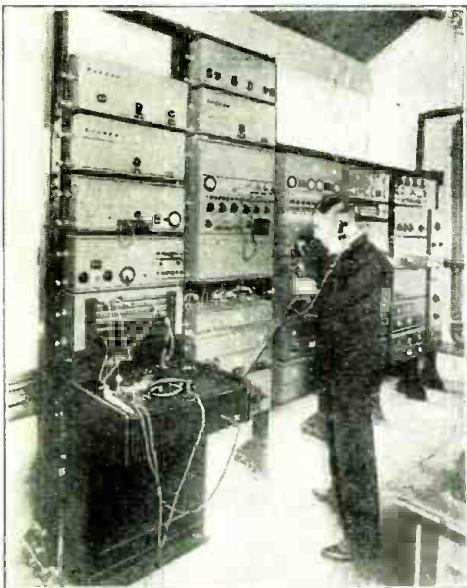

P. & A. Photo

An invention which is expected to revolutionize long distance wireless telephony and telegraphy will shortly undergo intensive tests in London, England. It is known as the Marconi-Mathieu Multiplex Apparatus, and is the combined efforts of Guglielmo Marconi and Mr. Mathieu, research engineer for Mr. Marconi. By means of this apparatus wireless telephony and telegraphy can be simultaneously operated on the same length wave by the Marconi beam system. Photo shows Mr. Mathieu with the receiving apparatus at the Bridgewater, England, beam station.

Relieving the Farmer



P. & A. Photo

While his body toils in his cornfield, Jesse Lincoln's mind is enjoying entertainment from all corners of the country. He is a farmer living near Liberty, Mo., and says, since he has placed a small two-tube radio set to his corn cultivator, the corn rows do not seem near so long now.

New Radio Photo Transmitter

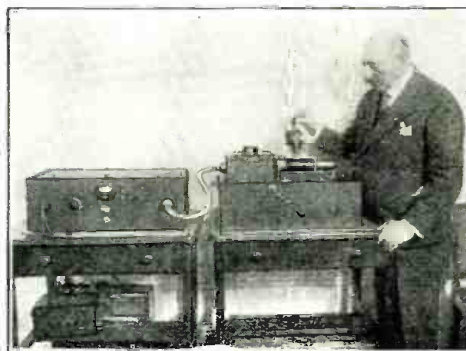

Wide World Photo

A new radio transmitter which transmits photographs, maps, etc., has recently been perfected by Capt. Otho Fulton and will transmit over either radio, wireless or telephone lines. One of the features of this machine, which has already been adopted in practically every country in Europe for the sending of weather charts, maps and the finger-prints of criminals, is that it is small and portable. Three and one-half to four minutes is all the time required.

Voice of St. Louis



This photograph shows the new transmitter at station KMOX, St. Louis, which was operated continuously for 186½ hours during the Jackson-O'Brine endurance flights.

German Plane Radio

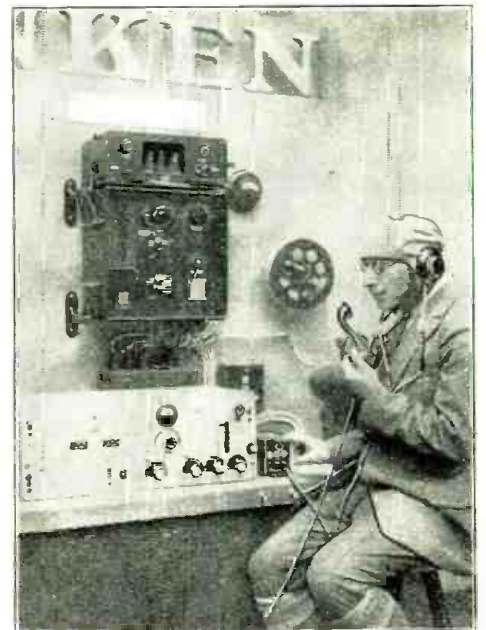

P. & A. Photo

Marking quite a contrast to the usual airplane radio sets is the complete radio equipment for airplanes at one of the exhibitions in Germany.

Plane Direction Finder

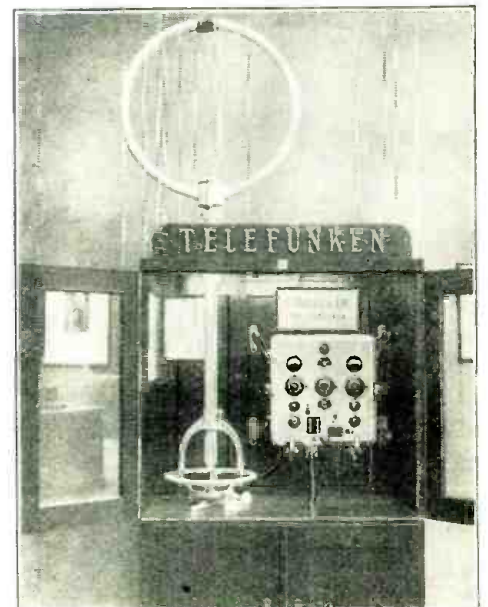

P. & A. Photo

The German radio equipment for airports enables location of plane in the air from which messages are received. Similar apparatus is used at sea.

Slot Talkie Machine



P. & A. Photo

An automatic "dime-in-the-slot" talking motion picture machine in an enclosed box-like apparatus was recently demonstrated by Robert C. Belgau, the inventor. When a coin is inserted, tiny red and blue "footlights" flash on, a curtain rises displaying a glazed glass screen approximately 24 inches wide by 20 inches high, and after the footlights are automatically dimmed the picture is flashed on the screen.

World's Smallest Voice

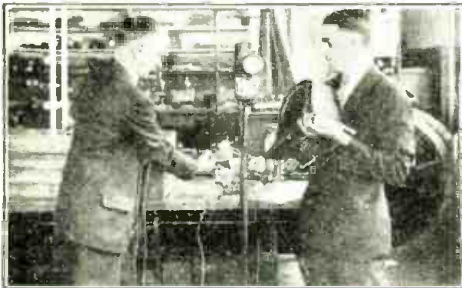

Wide World Photo

L. A. Hawkins, left, of the G. E. research laboratory, is holding a small piece of uranium before laboratory apparatus known as the Geiger counter, which amplifies the noise of exploding atoms so they can be heard. As they are heard in the loud speaker, this is held up before the "mike." Thus the "Voice of the Atoms" was recently broadcast over WGY.

Still at It

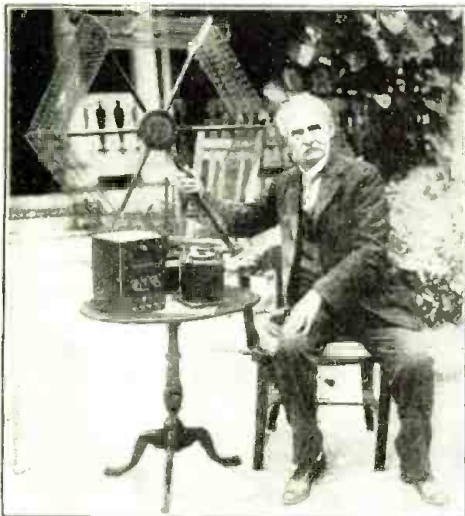

Wide World Photo

Dr. James Harris Rogers of underground radio fame is still active, despite his 80 odd years. During the war Dr. Rogers discovered he could intercept official reports of the German naval and military forces. Officials of the United States Government made very valuable use of his discovery.

Synthetic Chimes

The voice of Big Ben, London's famous clock, has been synthetically reproduced in the United States by radio station KDKA of the Westinghouse Electric and Manufacturing Co. KDKA first introduced the sound of the great old timekeeper to its listeners by relaying it from London through a short receiving set. Hearing these mellow sounds coming from his speaker, Dr. Frank Conrad, assistant chief engineer of the Westinghouse Co., conceived the idea of reproducing the same sound artificially. He turned his idea over to V. E. Trouant, radio engineer (shown in photograph) for application, and as a result the replica of Big Ben is broadcast by KDKA exactly upon the hour. The sound is not mentioned by the announcer. It simply is a note in the background of the program whether it be talking or music. At periods when the time is given by the announcer the syn-

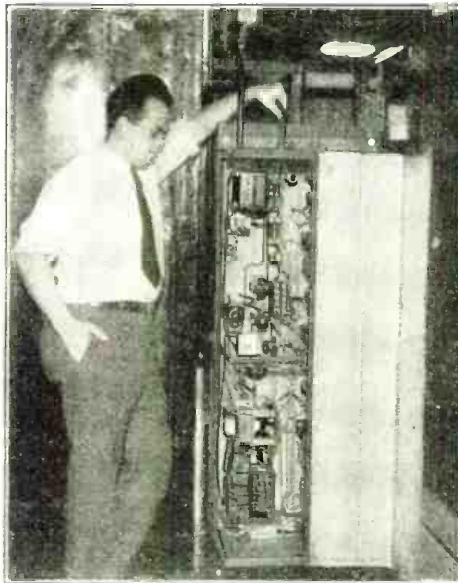

thetic bell is not used. When the sound is described as synthetic, exactly that is meant. It does not mean that a bell has been made which approximates the sound made by the London time-piece. Instead Big Ben is imitated by frequencies imposed on the radio set in Pittsburgh, which do not become sound until they reach the radio speaker. The tone is created by a number of oscillators, each one giving a certain frequency. These frequencies were selected through an analysis of Big Ben's tones. By combining the frequencies the same signal is carried to the transmitter and sent out on the air as would be produced by sounding the bell itself into a microphone. To insure absolute accuracy the artificial bell is set off by a second's beat pendulum clock which operates in a vacuum. The pendulum is made of an alloy which is unaffected by change in temperature. There are no mechanical connections to the clock, only electrical. The impulse from the pendulum controls a set of gears which in turn close the contact between the pendulum and the group of oscillators exactly on the hour. Then the synthetic bell is reproduced on thousands of speakers throughout the country, telling the listeners that another hour has passed.

Radio Veteran

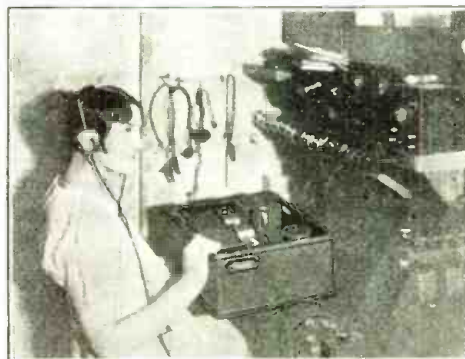

This "youthful veteran" has tested 160,000 receiving sets since she started working for the Crosley Radio Mfg. Co., in Cincinnati eight years ago. She is one of the most expert inspectors in the industry.

Tube Testing

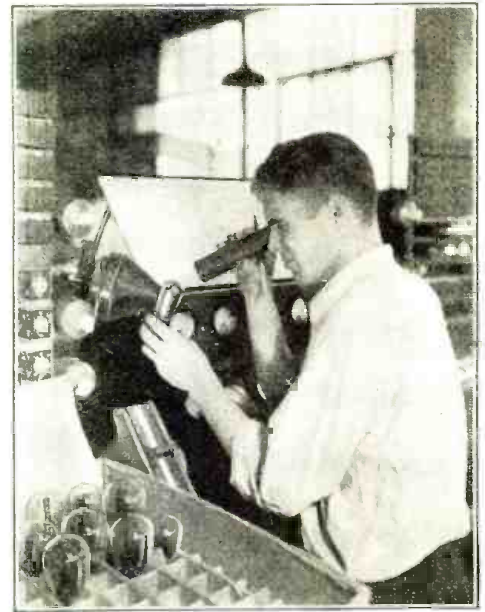

The human element as well as the mechanical is an important agency in the accurate testing of tubes, as is shown in the above scene in the laboratories of E. T. Cunningham, Inc., the radio tube company. Here the trained eye of the testing expert is examining the condition of the inner elements of a tube, aided by a magnifying glass and a special lamp.

Corn Stalks to Gas

The proposed utilization of corn stalks to be converted into gases starts with their removal from the field where they now serve only to harbor the corn borer. The stalks are collected in a closed fermentation tank and the farmer's household wastes are disposed of by running them into the same tank, where they provide

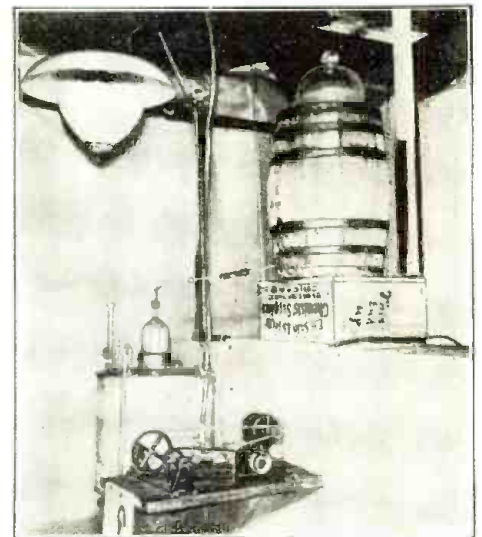

Wide World Photo

the necessary nitrogenous materials for the bacteria conducting the fermentation. The outcome is a gaseous mixture of carbon dioxide and methane, or marsh gas, which has a heat value equal to the ordinary gas supplied in cities. The gas could be used to run a generator and to charge storage batteries, supplying the farmer with electric light. The experiments were conducted by Prof. A. M. Buswell of the University of Illinois and his assistant, G. S. Boruff. The photograph shows the apparatus used in converting the corn stalks into gas.

Blind Plane Flies and Lands Safely

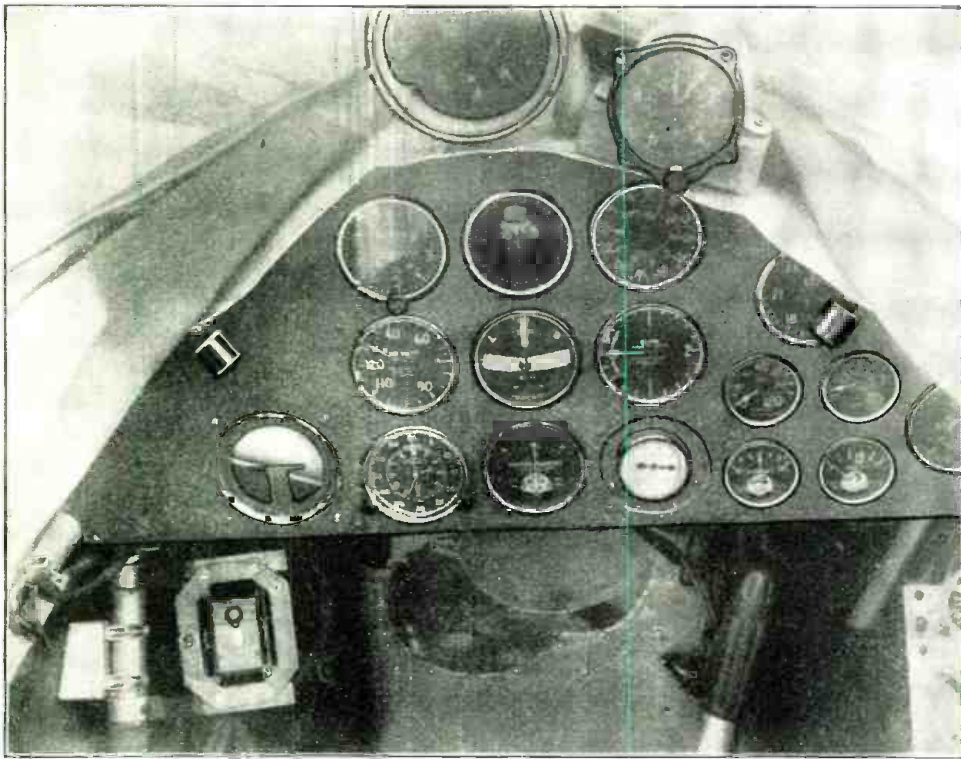

Wide World Photo

Man's greatest enemy in the air—fog—was conquered recently at Mitchel Field when Lieutenant James H. Doolittle took off, flew over a fifteen-mile course and landed again without seeing the ground or any part of his plane by the illuminated instrument board. The occasion was a final development of the Daniel Guggenheim Fund for the promotion of aeronautics and marked the first instance in which a pilot negotiated a complete flight while flying blind. Photo shows the instrument board of Lieutenant Doolittle's plane with the auxiliary instrument for

blind flying mounted. In the upper right-hand corner is the special altimeter which registers in 10-foot units instead of 100-foot units. In the lower left-hand side of the board is a Sperry Horizon which gives the pilot an artificial horizon for balance. Immediately below and mounted on the steel fuselage tubing is the radio direction finder which by means of two reeds enables the pilot to keep on a given course set by radio beacons. The other instruments are standard equipment on most planes.

Performs Impossible

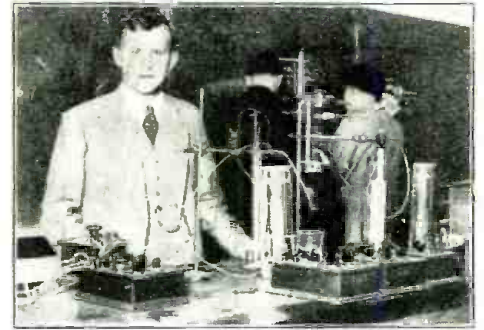

P. & A. Photo

Dr. K. F. Bohnhoeffer, young German scientist, who was an infantryman during the world war, has upset the scientific world by splitting an element, heretofore considered indivisible. He took hydrogen gas and changed it to an hitherto unknown form which he called parahydrogen. He demonstrated his feat before members of the American Chemical Society meeting at Minneapolis, Minn. Photo shows Dr. K. F. Bohnhoeffer with the apparatus he used to split the hydrogen, a basis element into a new form.

Count Water Drops



P. & A. Photo

Exhibited recently was a unique device for tallying the drops of water electrically. The water confined in a container drips rapidly on the mechanism, which is recorded on a meter attached to the contrivance. According to experts the counting is not rapid enough to undertake the measurement of the drop capacity of the ocean. It is the invention of Veeder-Root, Inc., of Hartford, Conn. Photo shows J. T. Quinlan demonstrating the water drop counting device.

Crime News Via Radio



Wide World Photo

Photo shows Commissioner Whaler using the new radio receiving unit which has recently been installed in his car. The commissioner has requested 500 of these machines to be installed in the department cars.

English Tele-Talkie Transmitter

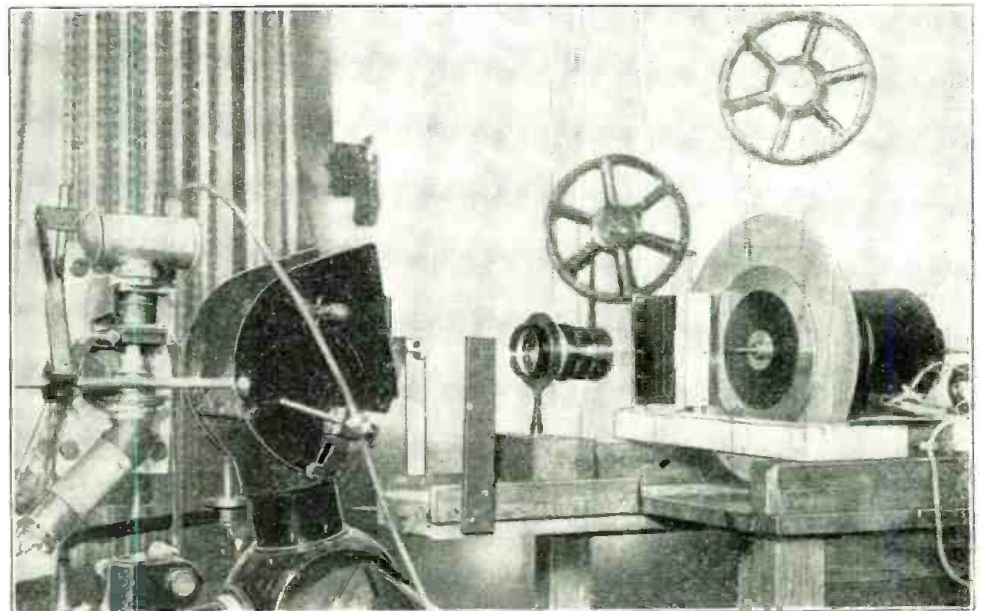

Wide World Photo

Photo shows a view of the television transmitter used in England by John L. Baird, Scottish inventor, which he uses to broadcast films and voices over the program of broadcasts. This is the essen-

tial part of the image and sound converter applied to a modern English broadcasting station when he recently demonstrated the system before a group of noted scientists and representatives of the British post office and the British Broadcasting Co.

There's More in a Storage Battery Than You Might Think

*Contrary to a Popular Idea Battery Does Not "Store" Anything;
Electro-Chemical Action in Next Article*

PART I

ALTHOUGH the day of the all-electric receiver is here, there are still many thousands of battery-operated receivers in use, especially in the rural districts where alternating current is not available. While there are a great many battery substitutes or eliminators available which are more convenient to operate and take care of, there is no substitute for the quiet, smooth and reliable operation of a good storage battery. By popular request we are publishing a series of articles prepared by the technical staff on the theoretical operation, care and maintenance of the lead-acid storage battery. While these articles are primarily intended for radio batteries, all conditions outlined in these articles are also true of automobile batteries and farm lighting batteries, with the exception of the Edison, steel-nickel cell, which will not be discussed due to the comparatively few in use.

The popular conception of the storage battery is that it literally stores up electricity, which has been passed through it during the process of charging. This is entirely a misconception of the true state of charging. The electric current which is passed through a battery when it is on charge

causes certain chemical changes to take place within it. These chemical changes are just reversed when the battery delivers current to the radio set, motors, lights, or automobile starter. The electricity from a storage battery is the result of an electro-chemical change during charging and discharging and not the releasing of something previously

stored or accumulated therein. The storage battery should, therefore, be considered as a reservoir for the electrical energy, which is required to operate the radio receiver, lights, or starting motor with an automobile. The energy so used in doing this work discharges the battery and it is then necessary to recharge the battery by some means, such as a generator, or a rectifier. Any storage battery will wear out eventually and the length of time that it will operate satisfactorily depends upon two things, the care in the manufacture of the storage battery and the care that is given them while they are in service. While it is not possible to see what goes on within the storage bat-

Contains Many Parts

The lead-acid storage battery is made up of many parts. The positive group of plates and the negative group of plates (the number of plates depends upon the capacity of the battery), the wooden or threaded rubber insulators, which go between the plates, the plate connectors, straps, the hard rubber jars, the hard rubber cap, the vent plugs, the top connector bar, the sealing compound which is used to seal the cap to the hard rubber jar, the electrolyte or acid and the wooden or hard rubber case which houses the entire unit. Each of these individ-

ual parts are made from certain specifications of certain materials. As the most important part of the storage cell, are the plates, these will be considered first.

There are two general types of battery plates, the Faure and the Plante. The Faure plate is the pasted type, which is almost universally used in the manufacture of all types of lead-acid

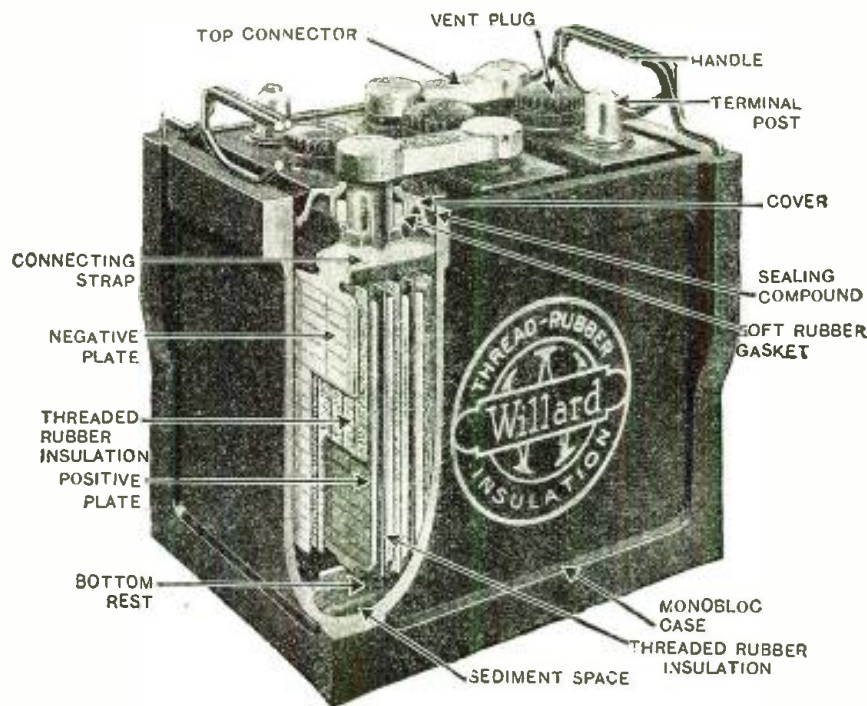

Fig. 1. A cut-out section of the storage cell showing the relative position of all parts contained



Fig. 2. A cross section of a storage cell showing separators, cap, post, plates and sediment pits

stored or accumulated therein. The storage battery should, therefore, be considered as a reservoir for the electrical energy, which is required to operate the radio receiver, lights, or starting motor with an automobile. The energy so used in doing this work discharges the battery and it is then necessary to recharge the battery by some means, such as a generator, or a rectifier. Any storage battery will wear out eventually and the length of time that it will operate satisfactorily depends upon two things, the care in the manufacture of the storage battery and the care that is given them while they are in service. While it is not possible to see what goes on within the storage bat-

Fig. 3. A skeleton grid before pasting



Illustrations Courtesy of Willard Storage Battery Co.



Fig. 4. A finished pasted and dried plate

storage batteries. There are several steps in the manufacture of a Faure pasted plate and these will be discussed in the order of manufacture. The grid is the skeleton of the plate, just as the bones of the body are the skeleton of the body. This performs the function of supporting the active material, which is of a very mechanically weak nature, and conducting the current to and from the cell. This grid is made of a lead antimony alloy, which is poured into a mould in a molten state. Pure lead is entirely too soft and also is very easily attacked by the electrolyte and, therefore, antimony is added to give the desired stiffness to the plate and resistance to the action of the electrolyte in the cell. The amount of antimony usually varies in different makes, depending upon the opinion of the engineering department of the manufacturer. In most cases it will probably average from eight to ten per cent. The casting of the grid is usually done by hand and requires considerable skill, as the proper composition of the metal and the temperature of both metal and mold being of great importance in securing perfect grids. If the metal is not kept at a constant temperature, there will result what is known as a "cold shot." A "cold shot" consists of an improper filling out of the ribs of the grid, which results from variations in temperature of the metal. The dross must also be kept free from the metal, as this will accumulate in the ribs and cause the rib to be physically weak and very probably rejected by the inspection department. The grids for the positive and the negative plates are identical and therefore no classification is made at this point. The grids are usually cast in pairs of two, which is quite logical and speeds up production to a great extent.

Pasting the Grids

When the grid castings have cooled, they are removed from the mould and passed to a trimming machine, which trims off the casting gates and the rough edges, trims the flash and straightens them. The grids are then given a



Fig. 5. A wooden separator showing the grooves in one side

very rigid inspection and those which show defects, such as shrunken or missing ribs, or "blow holes," are rejected and sent to the lead smelter, where they are refined for reclamation of the lead, which is, of course, used again. The grid is then ready for what is called pasting. In Fig. 3 the completed grid after having been trimmed and inspected is illustrated and is now ready for the pasting process.

There are a great many different formulas for the pastes which are applied to the plates and later converted into active material and each is generally considered as a trade secret by the manufacturer who uses it. However, the basis of all pastes, an oxide of lead, which may be either red lead (Pb_3O_4), litharge (PbO), or a mixture of the two, which is made into a paste with a liquid, such as diluted sulphuric acid (H_2SO_4). The reason for mixing



Fig. 6. This illustration shows a typical threaded rubber insulator

the oxides with a liquid is so that a paste is formed of such consistency that application to the grid is possible and to introduce at the same time the proper amount of binding or setting agent, which will give porosity and bind together the active material, especially so in the positive plate. The red lead oxide usually predominates in the positive plate and litharge in the negative. This combination requires the least energy in forming the oxide to active material. The lead oxide as used in the formula for a paste are dry powders and in this dry condition could not be applied to the grid as they would fall out. When mixed with a liquid to make a paste, the greater coherence enables them to be applied to the grid without falling out. Sulphuric acid will put the oxide in the desired pasty condition, but has the disadvantage of causing a chemical action to take place, which changes a considerable portion of the oxide to lead sulphate, which makes the paste stiff and almost impossible to apply to the grid. Therefore, when sulphuric acid is used, it is necessary to work very fast after the oxides are mixed with the sulphuric acid to form the paste. In addition to the lead oxide, the paste may also contain some binding material, such as ammonium or magnesium sulphate (MgSO_4), which will tend to bind the particles of the

Fig. 7. A magnified portion of a threaded rubber insulator, showing the cotton threads



active material together. The paste as used in the negative plate may contain a certain amount of lamp black, which gives a greater porosity.

Forming the Plates

After the plates are pasted, they are dipped and dried. Drying is effected either by letting them dry in the open air or are placed in rooms or tunnels where air is blown over them. The plates may then be handled without a loss of paste from the grid. The next step in the manufacture of plates is to change the lead oxide into active material, which makes the cell operative. This process is what is called forming and is practically nothing but a very prolonged charge at a very low rate. This forming process usually takes several days. In some factories the plates are placed in tanks which have slotted grooves in them and the plates are then placed in these slots, alternating positive and negative plates. The plates are then immersed in a very weak solution of sulphuric acid (H_2SO_4). A very low charging current is then passed through the complete unit. In other factories the positive plates and the negative plates are formed in separate tanks against what is called dummy electrodes. The passage of a very weak current through the plates and the electrolyte gradually changes the mixture of lead oxide and lead sulphate, forming brown peroxide of lead (PbO_2) on the positive plate and a gray, spongy metallic lead on the negative plate. The formation by the current of lead peroxide and spongy lead on the positive and negative plates would take place if a composition of the two pastes were identical. The difference in composition of the pastes for positive and negative plates is for the purpose of securing the property of porosity and physical condition best suited to each. When the forming process is complete, the plates



Fig. 8. The positive and negative plates ready for assembly with the separators

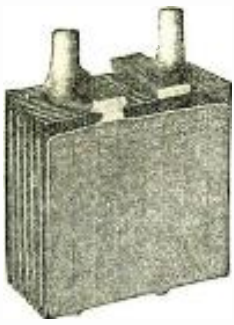

Fig. 9. A cell unit ready for placing in the jar

are then washed and dried. The washing process is necessary as the plates have accumulated a certain amount of acid and if let dry in air the chemical action of the air on the acid would cause heating and lead sulphate would be formed in excess quantity and the plate would not be healthy. The plates are then dried and ready for use in the battery. In Fig. 4 is shown the same grid after having been pasted and dried. This plate is now ready for the forming process.

The finished plates may be very easily recognized by their colors. The negative plate will be a dark slate gray and the positive plate will be a chocolate brown. The plates are then burned into what is called "groups" by a strap which connects them at the top, as may be seen in Fig. 8. The number of plates per group is determined by the amount of capacity desired per cell. The more capacity desired the greater the number of plates. There is always one more negative plate than there are positive plates. There will always be an even number of positive plates and an odd number of negative plates.

Separators as Insulators

Inasmuch as if two of the plates should happen to touch, it would cause a short circuit and discharge the battery it is quite necessary that some means of insulation be had between the plates. The most common method of insulation is to place between the plates what is called a separator. This is usually made of wood, which is of a very porous nature. The most used woods are Port Orford cedar, basswood or cypress. Redwood and cherry are also used to some extent. The wood that is used for these separators is first cut into strips of the correct thickness and are then passed through a grooving machine, which cuts small grooves on one side. These grooves extend across the entire face of the separator. The strips are then sawed to the correct length and are then treated by means of boiling in a warm alkaline solution for approximately 24 hours to neutralize any organic acid, such as acetic acid, CH_3COOA , which the wood naturally contains. The presence of acid in the separator would render unsatisfactory battery action and possibly damage the battery. The separator is placed between the positive and nega-

tive plates with the grooves always towards the positive plate and also the grooves are always in a vertical position, which will permit any shedding of the positive plate to drop down to the bottom of the jar into the sediment pit. Some makes of batteries use a double separator which is the conventional wooden separator which we have just described plus a thin sheet of hard rubber which contains a great many fine perforations. The rubber separator is placed between the positive plate and the wooden separator. This perforated rubber sheet is usually called a retainer, the purpose of which is to hold the active material of the positive plate in place and prevent as much shedding as possible. The slots in these retainers are of such size and in such great numbers that it will not very greatly hinder the passage of the acid to and from the plate surface. Farm lighting batteries and other batteries having a very low current drain do not require as rapid a



Fig. 10. A completed cell unit ready for assembling into the case

passing of electrolyte as those undergoing heavy duty service. Therefore, the wooden separator may be entirely dispensed with and a slotted rubber separator used. The objection to the wooden separator is that it is attacked by the electrolyte and will deteriorate in a length of time, which will, of course, cause shorts between plates. The Willard Storage Battery Co. has developed what is called a threaded rubber insulator. This consists of a corrugated rubber sheet through which have been placed thousands of cotton threads, such thread being as long as the separator is thick. The electrolyte is then carried through the separator by means of capillary action through these threads. These cotton threads are so numerous that an unusually rapid diffusion of electrolyte is obtained when exceptionally high current drains are taken from the battery. Fig. 6 shows one of these threaded rubber insulators as it appears to the eye and Fig. 7 shows a magnified section of this insulator showing the cotton threads which pierce the rubber. These insulators will not wear out within the life limit of the plate.

The positive and negative plate groups are then placed together as illustrated in Fig. 8. The separators are then inserted between the positive

and negative plates with the grooves in a vertical position, facing the positive plate. The completed cell unit with the separators in place is illustrated in Fig. 9. It is then ready for assembly into a cell unit. The unit is then placed in the hard rubber jar and the hard rubber cap is fitted over the post. Some sort of a seal is usually made between the post and the hard rubber cap, such as a lead seal or a soft rubber ring seal. A nut is then generally screwed down on the threaded portion of the post, which makes a tight connection, to prevent any leaking of acid. Sealing compound is then poured around the edge of the hard rubber cap which also seals the cap to the jar, making the complete cell unit leakproof. This cell unit is illustrated in Fig. 10. The cell is then filled with electrolyte to a point $\frac{3}{8}$ of an inch above the separator top, as illustrated in Fig. 11.

In batteries where a hard rubber case is used, the hard rubber jars are not generally used but partitions are provided in the case along with the sediment pits which, of course, take the place of the jars very readily. In this case the cell elements are placed directly in the partitions, the caps fastened on, sealed, and the top connectors burned into place. The battery is then ready for use.

Another Article Coming

In the succeeding articles in this series, there will be described the factors in the determination of capacity ratings. The effect on capacity ratings of high and low temperatures the correct electrolyte densities to be used at different operating temperatures and

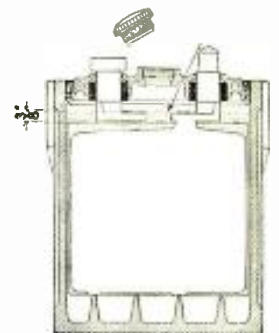

Fig. 11. Cross section of cell showing height at which the water should be maintained

the effects on plates of high temperatures. Charging rates and the effects on plates of undercharging and overcharging. These will be described and illustrated the electro-chemical changes which take place within the lead acid storage cell when it is charged and discharged. There will also be described the causes and corrections of sediment shorts, buckled and warped plates, disintegrated plates and separators, starved plates, mushy plates, normal and chronic sulphation. There will also be other information which should be useful to the user of a lead acid storage cell especially in non-a. c. districts.

EVERYONE possessing a radio receiver is familiar with the slogan which is made the title of this article, but not every listener is acquainted with the many steps and processes that go on behind the simple statement of "Please stand by for station announcement." While it may be a comparatively easy job to the average listener to bring music into his home via the radio set, nevertheless it isn't quite so easy for all of the machinery to be set in motion that insures the reception of a perfect program from the standpoint of tonal quality and volume.

On the technical staff of the National Broadcasting Co., or any other chain system, the unseen and seldom mentioned people behind the radio scene, falls the real responsibility of success or failure of the broadcast.

Long before the broadcast is made



Photo courtesy National Broadcasting Co.

Fig. 1. Dr. Alfred N. Goldsmith, N. B. C. consulting engineer, and O. B. Hansen, N. B. C. manager of plant operations and engineering, standing before a section of the main control board during a recent transatlantic broadcast

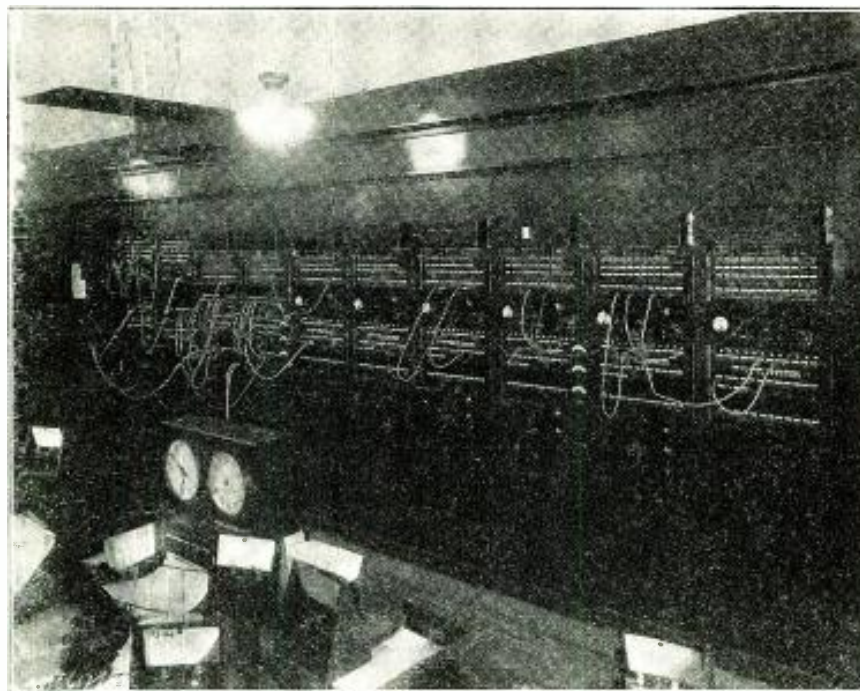

Photo courtesy National Broadcasting Co.

"Please Stand By for Station Announcement"

Process by Which Chain Programs Reach the Listener Is Interesting—Miles of Wire Involved and Hundreds of Employees on Watch Constantly to Insure Perfect Transmission

the technical workers must be on the job. Microphones must be placed to pick up the music and any old place won't at all do for the microphones. The room or hall in which the orchestra is to play is tested for acoustics. Then the placement of the orchestra is worked out. Every instrument is located in a certain position with regard to the microphone. Brass and percussion are furthest away with reed in the middle ground and the strings close up. This is done in order to obtain proper balance. With an orchestra in proper balance the brasses play their important part without muffling the sweet notes of the strings. With the problem of microphone and orchestral placement worked out, wires between the place of the broadcast and the main control room of the chain system must be tested. Sometimes it is necessary to mute the room with heavy hangings in order to eliminate objectionable echoes. Two microphones are often used, one directly in front of the orchestra and the other hung from the ceiling to give an auditorium effect.

Preliminary Work

A microphone mixing panel and an amplifier are then set up in the broad-

casting place in such a way that the operator of the mixing panel may have a clear view of the orchestra.

Everything is now ready for the broadcast. In order to trace the music from the orchestra to the home of the average listener, we will take one bit of sound. Assume the clarinet player, happy because of a solo passage in the orchestration, has just caused a bleated "waa-waa" to sound. The vigilant microphone instantly picks up the "waa waa" and sends it over a short length of wire to the mixing panel. Here the technical qualities of the "waa waa" are revealed by a visible needle set in a small black box on top of the operator's control board.

Watch Volume Carefully

If the needle jumps too far across the dial, the operator knows that there is too much volume and his hand, never off the control knob, tones down the sounds that are going out on the air. If

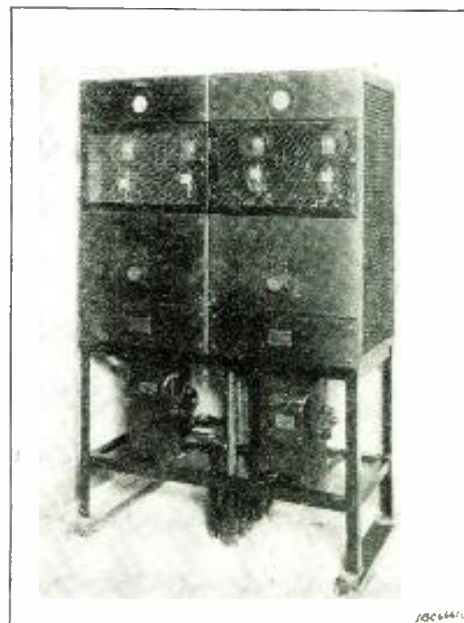

Photo courtesy National Broadcasting Co.

Fig. 2. Speech amplifier of station WJZ of the National Broadcasting Co. system



Photo courtesy National Broadcasting Co.

Fig. 3. George McElrath, operating engineer for the National Broadcasting Co., who was in charge of the company's installation for the inaugural broadcast at Washington last March, is shown testing the many microphones used for the pick-up. Miss Alice Brazer, McElrath's secretary, is assisting him on the delicate inspection

the "waa waa" is faint and weak, the operator builds up its volume.

After the musical note has been properly regulated, it goes to the amplifier where it is built up or boosted in order to go the several miles of telephone wire to the main control room in the chain headquarters. In order to eliminate ordinary wire noises, always present on telephone circuits, the clarinet note goes through another amplifying system and through a special device known as a pad. The pad acts as a filter separating the wire noises from the broadcast music.

At the central control room, such as the one illustrated at the beginning of this article, another needle on a volume indicating meter provides an additional means of checking the music before it goes on the air.

After being amplified, the "waa waa" goes to the big switchboard in the central control room and is borne over telephone wires to the WEAF transmitter at Bellmore, Long Island. At Bellmore the music note enters the radio transmitting apparatus and then goes out on the invisible ether channel to be picked up by the receiving set of



Photo courtesy National Broadcasting Co.

Fig. 4. Engineers of the National Broadcasting Co., George McElrath, right, N. B. C. operating engineer, and Albert E. Johnson, N. B. C. Washington Division engineer, shown in front of the United States Capitol arranging for the broadcasting of Herbert Hoover's inaugural address



Photo courtesy National Broadcasting Co.

Fig. 6. The late John B. Daniel, National Broadcasting Co. announcer, shown in a characteristic pose

the average listener. At the transmitter the "waa waa" is again boosted.

If the program is being broadcast over a network, the music leaves the main switchboard over a dozen or more telephone wires for radio transmitters scattered from coast to coast. Yet while Bellmore is just a few miles from New York and Kansas City is many hundreds of miles, the music goes on the air from the two stations at the same time.

Diagram of Processes

It will be seen from the diagram in Fig. 5 that the voice or music starts on its journey at the microphone, this being located in the studio. Then it courses through the mixer and a three stage amplifier equipped with a level

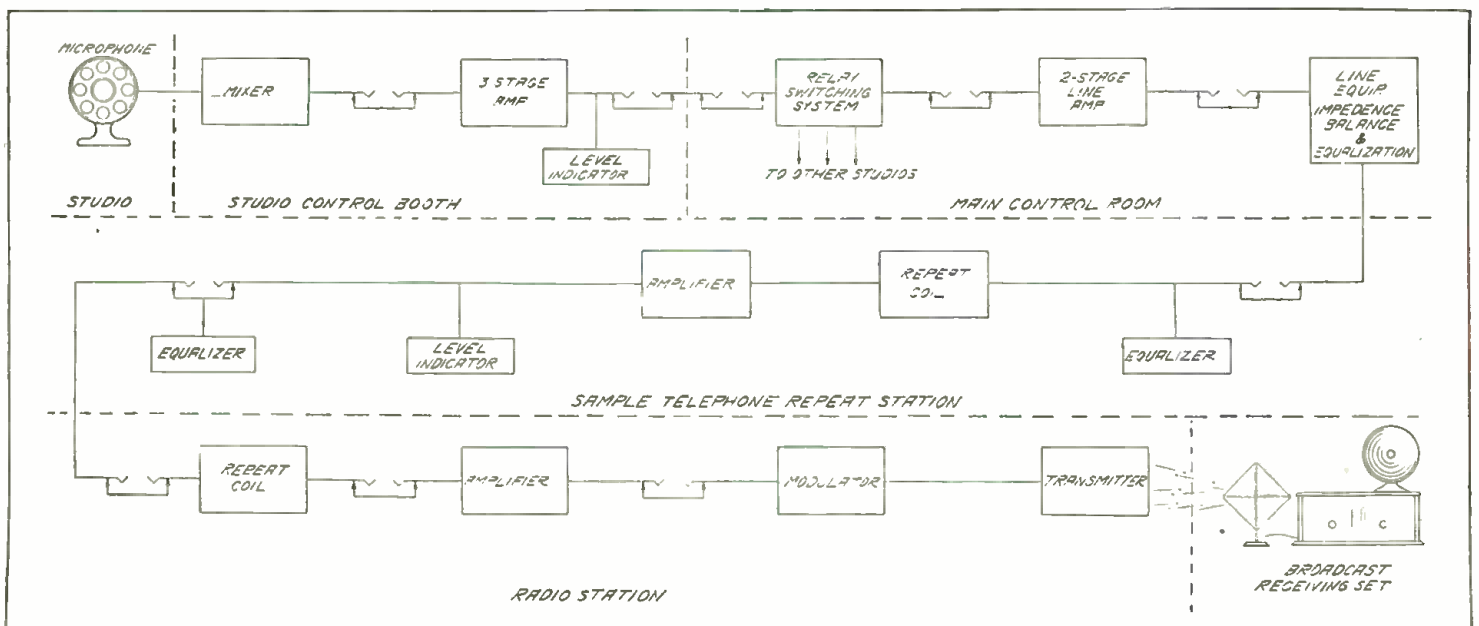

Fig. 5. The graphic diagram above shows the sequence of the broadcast transmission from the time it is placed before the microphone until the time that it is picked up by the broadcast receiving set

indicator, this apparatus being in the studio control booth. From there it goes to the main control room, which consists of a relay switching system to other studios, a two stage line amplifier and line equipment for impedance balancing and equalization. In the center of the diagram is shown a sample telephone repeat station which consists of an equalizer, a repeat coil, another amplifier, a level indicator and another equalizer. This sample telephone repeater may represent either a mile of wire or a thousand miles of wire, depending on the distance between the main control room and the furthest station linked with the chain. In the radio station the musical notes enter a repeat coil, then an amplifier, then into the modulator of the transmitter and thence into the transmitter itself to be sent out over the air. The final stage in the entire process is the broadcast receiving set and the speaker.

Although the function shown in the diagram in Fig. 5 seems to be rather bald, and lifeless, nevertheless in each one of the processes there is involved the presence of not only one technician but many. The number of men employed in handling the program depends largely on the location itself. For example, in the studio only the control operator might be required, aside from the announcer. However, in the main control room there are several employees and when the repeater stations are considered it brings the total

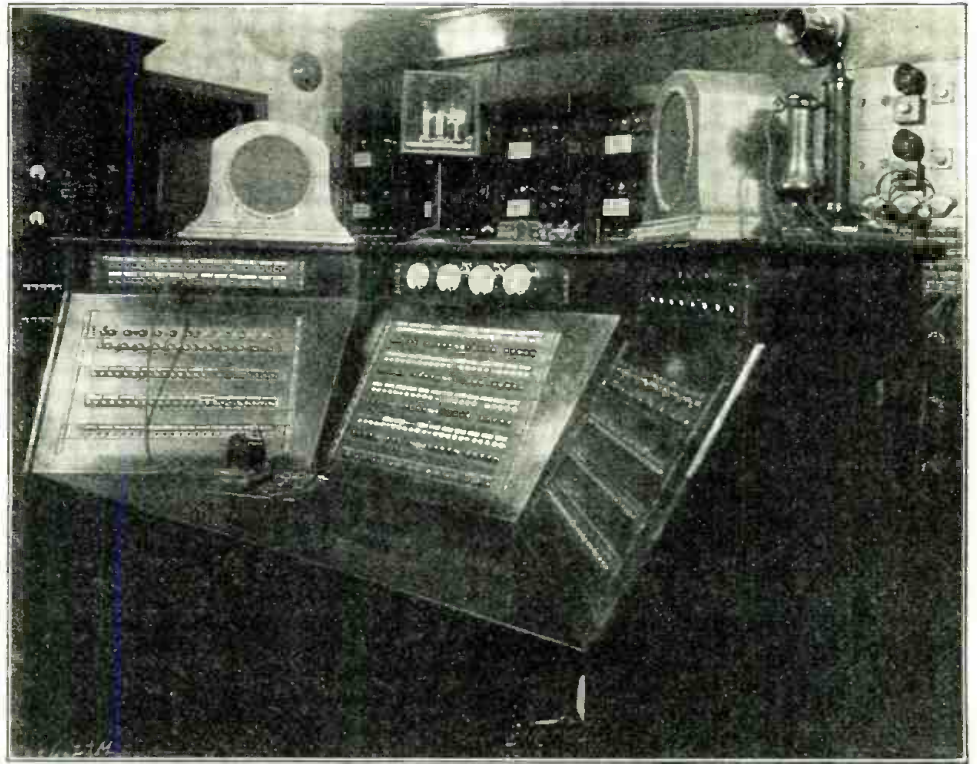

Photo courtesy National Broadcasting Co.

Fig. 7. The above view is of the network superintendent's control desk in the National Broadcasting Co.'s building

up to a large number, because the entire line must be patrolled. Then again when one considers the number of long distance telephone lines that are used for the linking together of long chain networks, the total of workers is rather amazing.

Those who are statistically inclined might like to figure out the number of miles of wire involved in these programs when a network consists of 30 or 40 stations in as many parts of the country and a wire hook-up is made from each of these distributing points back to the central studio in New York. In addition to the chain employees on the chain's own system, there is also some one at each of the broadcast stations to look after the interests of the network program.

Vigilant Employees

The fact that a hitch seldom occurs on a chain program is but evidence of the alertness and the patience of all of the employees involved as well as a tribute to the smooth working properties of the vast broadcasting system. And this does not alone apply to the electrical technique of broadcasting but to the announcing as well.

For example, recently Milton J. Cross, veteran WJZ announcer of the National Broadcasting staff, has been awarded the first prize for diction. At the same time William G. Hay now announcer at the WMAQ station at Chicago, which is one of the Columbia system's outlets, was awarded honorable mention. Announcers on the chain system undergo a rigorous training to insure that there shall be no slip in the continuity of the program being broadcast. Announcements and situations are often rehearsed weeks in advance and gone over and polished up until they fairly scintillate with interest. The day

(Continued on page 131)

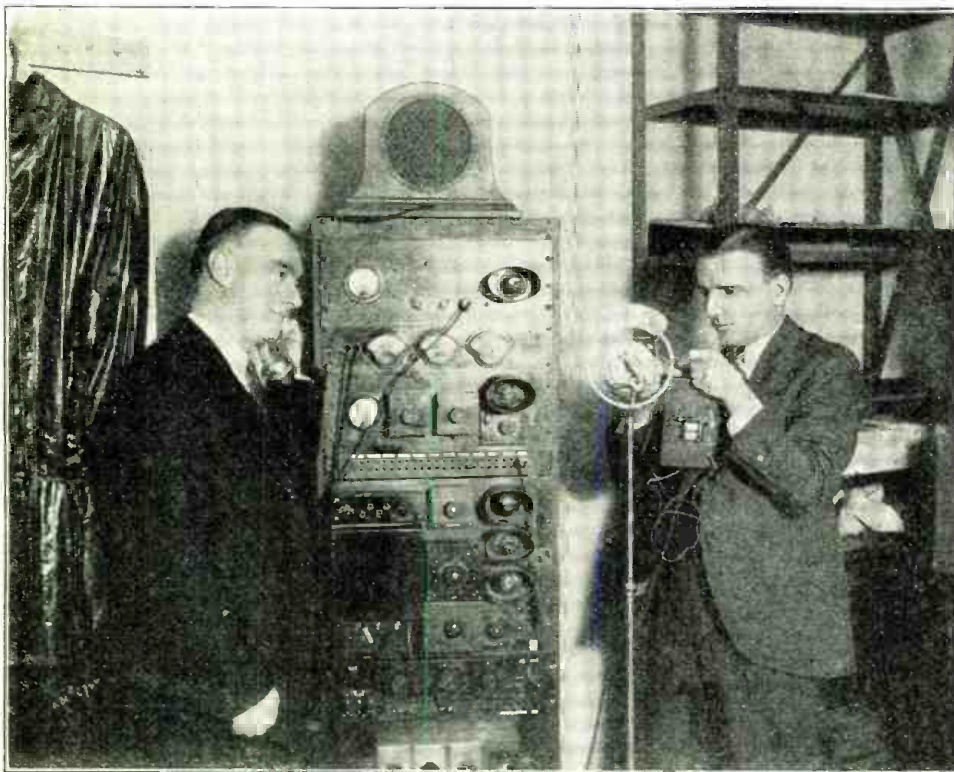
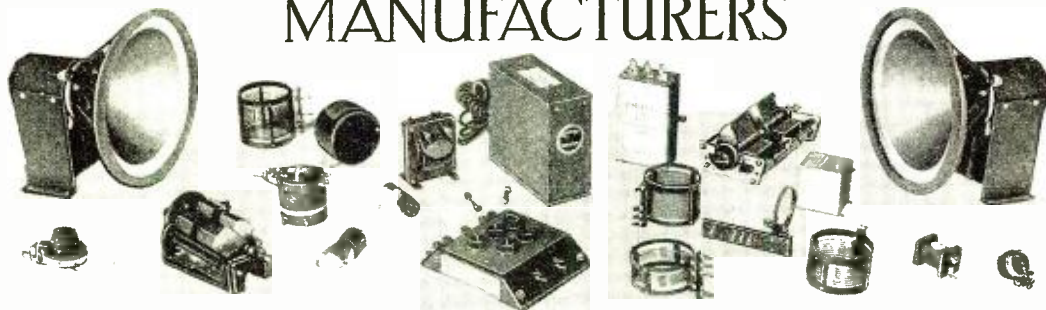

Photo courtesy National Broadcasting Co.

Fig. 8. This picture shows George McElrath (right), N. B. C. operating engineer, testing a microphone, while A. R. Cullen (left), of the N. B. C. engineering department checks the behavior of a portable control panel. Back of Cullen may be seen one of the N. B. C. plant operation and engineering department rain-coats, which is more likely to be used to shelter expensive equipment than the man who operates the broadcasting apparatus in case of rain

WITH THE ACCESSORY & PARTS MANUFACTURERS



Number of Tests Made Possible with the Supreme Diagonometer

EVER since the increase in the number of alternating current operated sets service men have been finding that service work became more complex than ever and that test work could not be accomplished merely with a C battery and a voltmeter. Accordingly the trend on the part of makers of test sets for service men has been to include within their units circuit arrangements that will take care of almost any



Fig. 1. This illustration shows the top of the Supreme diagonometer described in the accompanying article

conceivable condition that might arise in the servicing of a. c. or d. c. sets.

This has been particularly noted with respect to the Supreme Diagonometer manufactured by the Supreme Instrument Corp., Greenwood, Miss. One of these test sets has recently been operated in our laboratory and many features of interest to service and repair men have been observed.

In this article are shown three views of the instrument itself, the illustration in Fig. 1 being a front view of the instrument installed in a convenient carrying case with space for all tools and spare tubes. The photograph in Fig. 2 illustrates the diagonometer removed from the case and showing adapters and all accessories that go with the instrument. In Fig. 3 the rear of the Supreme diagonometer is photographed and gives the service man an idea of the pin jacks located on the back side of the instrument through which access can be had to all of the apparatus contained therein for external use. With the multiplicity of circuits contained in the instrument tray and the numerous combinations that can be affected, there is almost no limit to the tests and functions of this equipment.

The Model 400-B which is illustrated in this article is provided with a self-contained power plant for performing functions where various predetermined voltages are required.

Power Plant Inside

Within the instrument as a part of the power plant is a stepdown transformer tapped in the secondary for using ordinary house lighting a. c. to provide the voltages required. This power transformer has a 110 volt 60 cycle primary winding with the tapped secondary furnishing voltages of 1.5, 2.5, 3.3, 5, 7.5, 10.3 and 15 volts with a selector switch arrangement for connecting any one of these voltages to the filament circuits of the tube testing sockets as desired. By the use of the selector switches the plate and oscillating circuits are automatically closed, at the same time disconnecting the power plant from other parts of the instrument. Through the use of a master plunger in the 110 volt a. c. line jack, it is possible to take readings of the line voltage being supplied the power plant primary at anytime during the test, thus permitting the service man to make allowances in his test for line voltage variation. When powered from the a. c. lighting circuit meters and parts of the instrument are given maximum protection through the use of protection resistors and other devices.

For Balancing Condensers

Realizing the necessity for proper synchronization of vari-

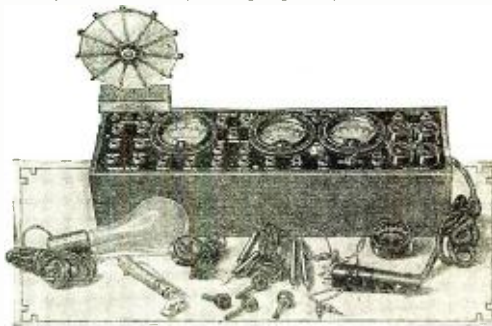

Fig. 2. In this illustration is shown the tray removed from the case. All accessories that go with the instrument are grouped in the front of the tray

able condensers for maximum receiving set operation. Supreme engineers have given particular attention to this problem. As a result there are made available in this instrument two accurate meter methods for accomplishing this adjustment. The
(Continued on page 131)

SM

Here's the Very Tuner for Rack-and-Panel and All "Class" Installations

Never was there a tuner like the new S-M 712! Built along the peculiar lines of design which resulted last year in the unprecedented supremacy of the Sargent-Rayment 710, the 712 embodies every advantage and every essential engineering feature of its famous predecessor. Yet, along with its peculiarly perfect shielding, its five tuned circuits, and its precision coils, it has brand new features which add wonderfully to the charm of its outstanding performance—all-electric operation, strictly one-dial control (no verniers), band-selector tuning, power detection—culminating in a radio receiver which the most exacting engineer may be proud to install anywhere.

Even in rack-and-panel construction, where the finest possible performance is required, regardless of cost, the S-M 712 is absolutely ideal—and there are no projecting flanges on the front side of the tuner to prevent a neat job of bolting direct to any panel. *Low-impedance power detector permits its use with any standard amplifier.*

The 712 uses 3-'24 tubes, and 1-'27. It requires only 180 volts B, and 2½ volts for heaters. Price only \$64.90 net, less tubes, in shielding cabinet shown. Component parts total \$40.90.

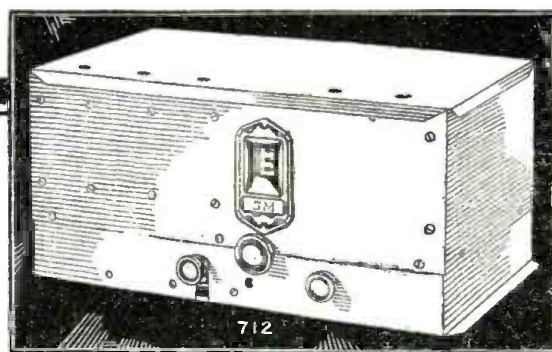

The new S-M 677 forms a perfect power supply, as well as an audio amplifier of appropriate superior quality, for use with the 712, or for records. Special input transformer has high ratio, ideal for phonograph pickup. Tubes required: 1-'27, 2-'45, 1-'80. Power comes from any 105 to 120 volt, 60 to 50 cycle source. Wired complete, less tubes \$58.50. Component parts total \$43.40. (For 25-40 cycle current S-M 67725 costs \$72.50 wired.)

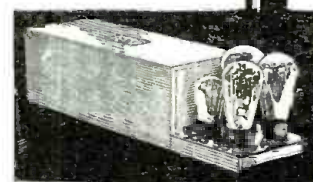

S-M 722 and 735 Show Marvelous Performance at Surprisingly Low Cost

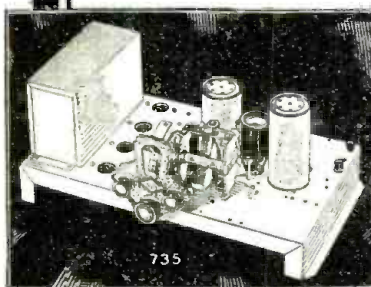

The first complete a.c.-operated short-wave receiver is the new S-M 735, which costs, wired complete with built-in ABC power unit, less tubes, only \$64.90. Tubes required: 1-'24, 2-'27, 2-'45, 1-'80. Component parts total \$44.90. 735DC, for battery use, is also described completely in the new S-M catalog—see coupon.

Broadcast reception approaching wonderfully close to the 712's magnificent standard can now be had in the S-M 722 (using 3-'24 tubes, 1-'27, 2-'45, 1-'80) at only \$74.75 net, complete with ABC power unit, less tubes.

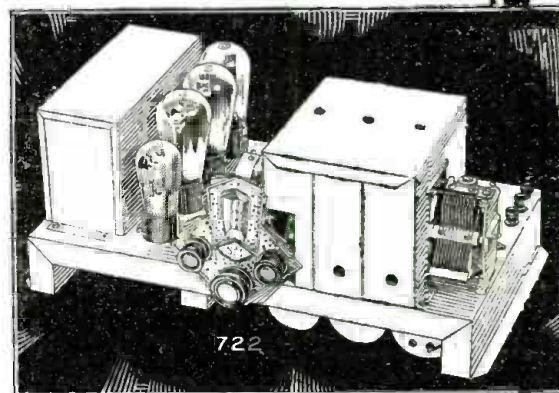

Silver-Marshall, Inc.
6413 West 65th Street, Chicago, U. S. A.
Please send me, free, the new Fall S-M. Catalog; also sample copy of The Radiobuilder.

For enclosed.....in stamps, send me the following:

- 50c Next 12 issues of The Radiobuilder
- \$1.00 Next 25 issues of The Radiobuilder.
- S-M DATA SHEETS** as follows, at 2c each:
- No. 3. 730, 731, 732 Short-Wave Sets
- No. 4. 255, 256, etc. Audio Transformers
- No. 5. 720 Screen Grid Six Receiver
- No. 6. 740 "Coast-to-Coast" Screen Grid Four
- No. 7. 675 ABC High-Voltage Power Supply
- No. 8. 710 Sargent-Rayment Seven
- No. 9. 675 PD Phonograph-Radio Amplifier
- No. 10. 720 AC All-Electric Screen-Grid Six
- No. 12. 669 Power Unit
- No. 14. 722 Band-Selector Seven
- No. 15. 735 Round-the-World Six
- No. 16. 712 Tuner (Development from the Sargent-Rayment)
- No. 17. 677 Power Amplifier for use with 712

Detailed suggestions on 712 rack-and-panel installation are to be found in the RADIO-BUILDER for October—also new data on television amplification. If you are not getting it regularly—use the coupon!

Custom builders have profited immensely through the Authorized S-M Service Station franchise. If you build professionally, write us.

SILVER-MARSHALL, Inc.
6413 West 65th St., Chicago, U. S. A.

.....Name
.....Address

Tell 'Em You Saw It in the Citizens Radio Call Book Magazine and Scientific Digest

SM Recommended by S-M for Their Custom Receivers



The Best in Radio—
 (Left)—This beautiful lowboy cabinet is provided with genuine walnut veneer top and side panels, and front side panels of high-lighted, fiddle-back mahogany, all beautifully and harmoniously finished. Overall, 38½" high, 24½" wide, and 15½" deep; set compartment, 9" by 19½" by 12½" deep; speaker compartment, 12" by 21" by 12½" deep. No. 211SM Cabinet, \$18, net.

The Best in Cabinets—

(Right)—Top and sides of genuine mahogany plywood, front side panels of walnut with Carpathian elm overlays, and other like overlays on the five-ply "V" matched African walnut sliding doors, contribute to the surpassing beauty of this highboy. Overall, 50½" high, 27½" wide, and 16½" deep; speaker compartment, 12" by 23" by 13½" deep; set compartment, 9" by 23" by 13½" deep. No. 217SM Cabinet, price, \$30.00 net.

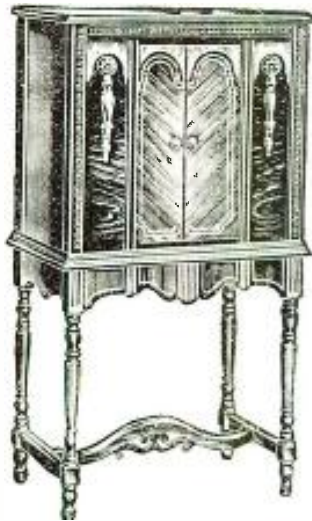

For combination phonograph and radio installation, this walnut cabinet with its butt-walnut full-folding doors is particularly excellent. A sliding drawer for phonograph turntable, pickup, and motor is provided in the speaker compartment, and special provision is made in the lower drawer for the S-M 677 Amplifier. Overall 54½" high, 33¼" wide, and 18" deep; set compartment, 9" by 27½" by 12" deep; speaker compartment, 12" by 28½" by 13" deep. No. 229SM, price, \$56.40 net.

Any of the above cabinets will take the S-M 712 and 677, 735, 722, or 735DC. If your jobber does not handle these special S-M cabinets, write us direct, enclosing 25% deposit if you wish the cabinets shipped C. O. D. (2% off for cash).



I. A. Lund Corporation

Cabinets by a Cabinet Maker

1018-1024 S. Wabash Ave. Chicago, Ill., U. S. A.



National Distributors S-M Parts and Receivers

The newest, the best, in radio—with S-M's superiority in tone-range, selectivity, and all other factors making for excellence—is offered in these receivers and parts. We handle the complete S-M line of parts and receivers. Get our new catalog—save through our speedy service and prices! We have a real surprise this year—**WE PAY THE POSTAGE—WE PAY THE FREIGHT.** (See 1930 Catalog for details.)

NET Price List (less tubes):

712 TUNER—677 AMPLIFIER
 No. 2W-36154. 712 TUNER. Completely Wired. S-M price, \$63.60
 \$64.90. Your NET
 No. W-36155. 712 TUNER. Complete Kit of Parts. S-M price \$40.90. Your NET 40.08
 No. 2W-0714. Type 677 wired for 110 V. 50-60 cycle operation. S-M price, \$58.50. Your NET 57.33
 No. 2W-0716. Type 677 in Kit Form. S-M price, \$43.40. Your NET 42.53

Our Stock Number	S-M Number	Name	S-M Price	Your Net Price
2W-36152	722	BAND-SELECTOR SEVEN (Wired)	\$74.75	\$73.25
2W-36153	722	Component parts of 722	52.90	51.84
2W-36156	735	SHORT-WAVE RECEIVER (Wired)	64.90	63.60
2W-36157	735	Component parts of 735	44.90	44.00
2W-36158	735DC	SHORT-WAVE RECEIVER (Wired, d.c.)	44.80	43.90
2W-36159	735DC	Component parts of 735DC	26.80	26.26
W-16209	131P	Plug-In Coil (163-343 meters)	.75	.73
W-16211	131Q	Plug-In Coil (273-592 meters)	.90	.88
(Above coils permit 735 and 735DC to cover Broadcast bands)				
2W-3354	707	Cabinet (for 735, 735DC, and 722)	7.75	7.60
2W-3353	211SM	Lowboy Cabinet	18.00	17.64
2W-3351	217SM	Highboy Cabinet	30.00	29.40
2W-3352	229SM	Combination Cabinet	56.40	55.27
2W-0705	690	AUDITORIUM AMPLIFIER (3 stage)	147.00	144.06
2W-0711	691	AUDITORIUM AMPLIFIER	147.00	144.06
2W-0710	69025	AUDITORIUM AMPLIFIER (25 cycles)	172.00	168.56
2W-0704	679	AUDITORIUM AMPLIFIER (250 tube)	62.50	61.25
2W-0715	67225	AUDIO AMPLIFIER (for 25 cycles)	72.50	71.05
2W-07106	678PD	Phono-Radio Amplifier (250 tube)	47.40	46.45
2W-3606	678PD	Component parts of 678PD	39.00	38.22
2W-0103	850	DYNAMIC SPEAKER UNIT (a.c.)	35.10	34.40
2W-0104	851	DYNAMIC SPEAKER UNIT (d.c.)	29.10	28.52
2W-3792	675	ABC Power Unit	37.80	37.04
2W-07108	675	Component parts of 675	32.97	32.31
2W-0709	669	ABC Power Supply for '45 tubes	28.30	27.73
2W-6708	669	Component parts of 669	23.08	22.62
W-4791	223	Hi-Mu Audio Transformer*	5.40	5.29
W-4786	225	First Stage Audio Transformer*	5.40	5.29
W-4787	226	Second Stage Audio Transformer*	5.40	5.29
W-1704	227	Push-Pull Interstage Transformer*	4.80	4.70
W-1707	228	Universal Output Choke*	4.80	4.70
W-1710	229	Dynamic Speaker Output Transformer*	4.80	4.70
W-1706	248	Universal Output Choke*	4.20	4.12
W-4788	255	First Stage Audio Transformer*	3.60	3.53
W-4789	256	Second Stage Audio Transformer*	3.60	3.53
W-4756	255M	Microphone Transformer*	4.80	4.70
W-1703	257	Push-Pull Input Transformer*	4.20	4.12
W-1735	258	Push-Pull Output Choke*	3.00	2.94
W-1720	230	Push-Pull Input Transformer	6.00	5.88
W-1721	231	Push-Pull Output Transformer	6.00	5.88
W-1717	220	Audio Transformer	4.80	4.70
W-1724	331	Clough-System Filter Unichoke	4.80	4.70
W-1779	338U	Filter Choke	2.10	2.06
W-1737	324	Power Transformer (750 volt)	15.00	14.70
W-1767	32425BU	Power Transformer (for 25 cycles)	18.75	18.37
W-4749	327	Power Transformer (550 volt)	9.00	8.82
W-1769	337U	Power Transformer (for '45 tubes)	10.00	9.80
W-1773	33725U	Power Transformer (for 25 cycles)	12.50	12.25

SHURE BROTHERS CO.

335 West Madison Street Chicago, Illinois

SHURE BROTHERS COMPANY, Dept. 332, 335 West Madison Street, Chicago, Ill.
 Please send your new big catalog of S-M and other makes of parts, sets, and radio supplies, with net POSTPAID PRICES.
 Name.....
 Address.....

SM

Have You Ever Tried Dealing With a House That Can Give You Personal Service?

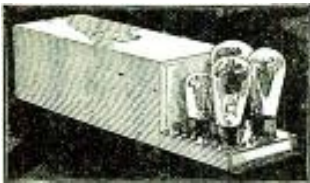

It Will Pay You To Write Us about the S-M 712 and 677

RADIO PARTS COMPANY

311 STATE STREET -:- MILWAUKEE, WIS.

SM

24-Hour Delivery on Your S-M 712

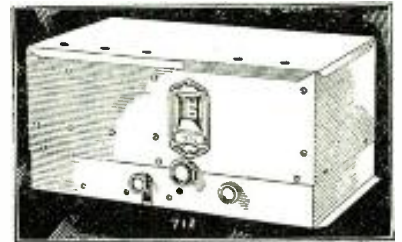

We Have Complete Stock of All S-M Receivers and Parts
SETBUILDERS: Write for wholesale catalog.

WEDEL COMPANY

Established 1888
 520 Second Avenue Seattle, Wash.

SM

On the West Coast It's Electric Supply Company for 712 and All S-M Parts

Dealers Send for Our One Hundred Page Free Mail Order Catalog Just Off the Press.

ELECTRIC SUPPLY COMPANY
 325 13th ST., OAKLAND, CALIF.

Please send me your dealer's and setbuilder's FREE Radio Catalog. Mark X

I am a dealer.....Setbuilder.....I have a store.....

Name.....

Address.....

FREE RADIO BOOK



WHOLESALE PRICES

This Wholesale Catalog Will Save You Money

Write today for our large illustrated new Catalog "C-1." Everything new in radio, including the new Screen Grid A. C. humless all-electric sets, as well as battery operated sets, priced as low as \$15.95.

ALLIED RADIO CORPORATION

711 W. LAKE ST. CHICAGO

You Build Better, When You Buy Right



Junior Rheostat

Small in size, but a master instrument. Ask your dealer to show you the exceedingly fine adjustment and velvet smooth action. Diameter, 1-7/16 inches.



Twin Jack

Economy in assembly and dependability in service recommend the Twin Jack. Efficient double contact springs and handsome Bakelite cap with following markings: "SPEAKER," "PHONE," "FIELD," "+ -."

VOLUME CONTROLS
 PHONE PLUGS
 RESISTANCES

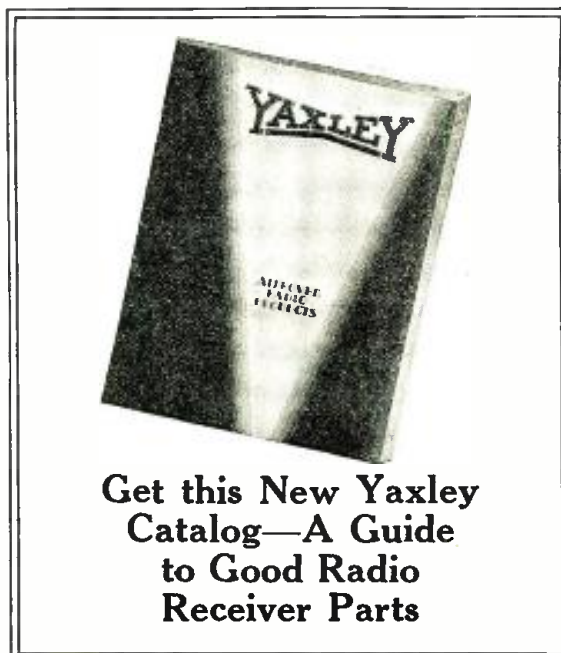

Get this New Yaxley Catalog—A Guide to Good Radio Receiver Parts

YAXLEY MFG. CO.
 Dept. C, 1528 W. Adams St. Chicago, Ill.



Air-Cooled Rheostat

Has watch-like precision, smooth, quiet action and extremely close adjustment. Meets the exacting requirements of a volume control in phonograph pick-ups.



Radio Convenience Outlets

Meet every radio wiring need. Brushed brass or Bakelite, single plates or in gangs of many combinations. Easy to install. Fit standard electrical outlet box or may be attached directly to lath or studding.

SWITCHES
 SOCKET ASSEMBLIES
 TERMINAL CLIPS

Tell 'Em You Saw It in the Citizens Radio Call Book Magazine and Scientific Digest

Recording Equipment for Talkies Uses Many Radio Principles

(Continued from page 106)

motors on the distributor system (that is, camera and disc recorder motors), run at the same speed as the distributor.

From the foregoing analysis of the method of synchronization in the Vitaphone recording system, it can be seen that there are two main requirements. First, that all of the driving motors must be lined up together and they must all start at the same instant, and run at exactly the same speed. This requirement is taken care of by the fact that all the rotors are electrically tied together, which means that when energy is applied they will all be electrically interlocked. The second requirement is that the speed shall be constant at all times. This is more important to the sound than to the picture because if there is the slightest variation in speed there will be a relatively similar variation in the pitch of the sounds being recorded on the wax disc. The d. c. distributor motor, whose speed is controlled by the d. c. control box, takes care of this second general requirement.

F. SUMMARY.

When a sound shot is to be taken by the Vitaphone method, the cameras in the studio and the disc recorders in the recording room are all lined up electrically. All machines start at the same instant, come up to normal running speed at the same time, and run at the same constant speed. Therefore, the action that is recorded on the film is exactly synchronized with the sounds that are recorded on the wax disc.

Vitaphone records are made from the wax discs on which the sound is recorded and the finished records look about the same as standard phonograph records, with the exception that Vitaphone records are 16 inches in diameter. They will play for approximately ten minutes, and the sound groove starts at the center instead of at the edge.

Movietone Recording

A. INTRODUCTION.

In view of the fact that we have discussed the Western Electric Vitaphone system of recording, which is a phonographic system, it is now in order to discuss the Fox-Case Movietone system, which is a photographic system.

B. STUDIO AND AMPLIFIERS.

In the Fox-Case system of Movietone recording, the studio requirements are just the same as those discussed under Vitaphone-Studio, but in Movietone recording, the amplifiers are installed right in the studio and operated there.

If several microphones are used, their outputs are brought to a mixing panel where the individual outputs from the separate microphones are controlled to strike a balance and the total output from all of the microphones is controlled to maintain the proper recording level.

The output from the mixer is connected to the input of a W. E. 8-B amplifier. (The 8-B amplifier is similar to the 8-C, the latter being a later model and embodying several modifications not incorporated in the former.)

The W. E. 8-B amplifier has two output circuits which allow for a 500-ohm output from the amplifier or a 4,000-ohm output. In the Fox-Case Movietone system, the 4,000-ohm output is used, and this energy is applied across the terminals of the recording lamp, which is sometimes called the flashing lamp. The commercial name for this is the aeo-light.

C. AEO-LIGHT.

The aeo-light is the heart of the Fox-Case Movietone system in that it is the means for changing electrical-current variations into light variations which are, in turn, applied to the negative film.

SERVICE MEN Use Potter Replacement Blocks and By-pass Units for Service Work



Code	Eliminator used with	Price
4341	Majestic Standard "B"	\$10.00
4343	Majestic Special Master	11.00
4347	Majestic Super "B"	12.00
4359	Majestic Master "B"	11.50
4360	Brown "B" Super Power (Green Brown)	11.00

22-54	Zenith ABC Power Supply ZB-9	\$12.00
572-S	Mohawk AC (27-28) 226 Type Power Unit	12.00
572-S	Stewart Warner	12.00



POTTER BY-PASS CONDENSERS

Code	Cap. D.C.	Working Voltage D.C.	Size	Price
A-1	.1 Mfd.	160	5/8" x 3/4" x 1-3/16"	\$0.60
A-2	.25 "	160	" " "	.70
A-3	.5 "	160	" " "	.75
A-101	.1 "	200	" " "	.70
A-102	.25 "	200	" " "	.75
A-301	.1 "	400	" " "	.85
A-401	.1 "	500	" " "	1.00



Code	Cap. D.C.	Working Voltage D.C.	Size	Price
AA-4	1. Mfd.	160	1-13/16" x 3/4" x 2"	\$0.90
AA-103	.5 "	200	" " "	.90
AA-302	.25 "	400	" " "	1.00
AA-303	.5 "	400	" " "	1.25
AA-402	.25 "	500	" " "	1.25

POTTER FILTER BLOCKS

RR-245	Condenser Block for single and push-pull 245 type tube amplifiers	\$19.75
T-2900	Condenser Block for the single 250 type tube amplifier	20.00
T-2950	Condenser for the push-pull 250 type tube amplifier	22.50
T-2098	Condenser Block for single 210 type tube amplifier..	20.00
T-280-171	Condenser Block for power pack with 280 type tube rectifier	18.00



Code	Cap. D.C.	Working Voltage D.C.	Size	Price
T 307-2-104	1. Mfd.	200	1 7/16" x 4 1/2" x 4 3/4" high	\$8.50
	1. Mfd.	200		
	4. Mfd.	400		
T 307	4. Mfd.	400	1 7/16" x 4 1/2" x 4 3/4" high	6.25
T 405	2. Mfd.	600	1 7/16" x 4 1/2" x 4 3/4" high	3.75
T 407	4. Mfd.	600	2 1/8" x 4 1/2" x 4 3/4" high	6.75
T 504	1. Mfd.	1000	1 7/16" x 4 1/2" x 4 3/4" high	2.75
T 505	2. Mfd.	1000	1 7/16" x 4 1/2" x 4 3/4" high	5.25
T 506	3. Mfd.	1000	2 1/8" x 4 1/2" x 4 3/4" high	7.75
T 604	1. Mfd.	1250	1 7/16" x 4 1/2" x 4 3/4" high	3.50
T 635	2. Mfd.	1250	2 1/8" x 4 1/2" x 4 3/4" high	6.75

The Potter Co.

North Chicago, Illinois
A National Organization at Your Service

The New Model 547 Radio Set Tester

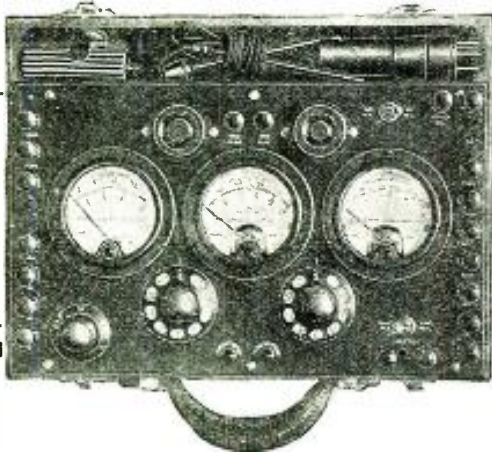

- saves time
- simplifies testing
- increases sales

Service men remember the time when radio set testing required hours of time and satchels full of equipment. The model 537 reduced radio set testing to its utmost simplicity and made radio servicing a profitable business instead of a necessary evil.

NOW—Model 547—for A.C. and D.C. Receivers meets the service testing requirements of radio's latest developments, even taking into account the number of new tubes, sets and circuits. Handsome in appearance, it is light, but rugged, convenient and complete.

Provided with three instruments, carrying case, removable cover, panels and fittings of sturdy bakelite.

A.C. Voltmeter—750/150/16/8,4 volts. Only one selector switch is necessary.
D.C. Voltmeter—high range increased to 750 volts.
Other ranges—250/100/50/10/5 volts.
D.C. Milliammeter—double range 100/20 M.A. provides for lower readings with better scale characteristics.

Tests—On A.C. sets the heater voltage and plate current can be read throughout the test while the D.C. voltmeter may be indicating plate bias or cathode voltage.

Self-contained, double-sensitivity continuity test provided. This can also be used for measuring resistance as well as testing for open circuits. Grid test can be made on A.C. or D.C. screen-grid tubes—also the '27 tubes when used as a detector—without the use of adapters. Two sockets on the panel—UY tube adapters eliminated.

Weston
PIONEERS
SINCE 1888

INSTRUMENTS

WESTON ELECTRICAL INSTRUMENT CORP.,
574 Frelinghuysen Ave., Newark, N. J.

The term "AEO" was derived from the three words, Alkaline Earth Oxide, by taking the first letter in each word. This seemed a fitting term to use because the coating on the negative electrode of this flashing lamp is an Alkaline Earth Oxide, and it is this coating which gives to the light the inherent properties which make it adaptable to sound pictures.

The aeo-light is a tubular-shaped lamp, about 6 inches long and 1 inch in diameter, inside of which there is a filament-shaped negative electrode and adjacent to this electrode there is a plate which is the positive electrode. The negative electrode, or filament, is covered with Barium Strontium, and the gaseous content of the aeo-light is about as follows: 1½ per cent nitrogen; 3 per cent neon; and 95½ per cent helium.

When about 350 volts, direct current, is applied across the "aeo-light," in series with 12,000 ohms, a bluish white glow is established within the tube. The d. c. voltage varies with different lights and is usually made of such a value that there will be a current of about 10 milliamperes flowing through the aeo-light circuit. The function of 12,000 ohms is to stabilize the aeo-light circuit, because with a gaseous tube of this type, after the gap between electrodes has become ionized, the impedance of this path is liable to become lower and lower until it is practically a short circuit. The stabilizing resistor obviates this possibility.

When the aeo-light is energized with the d. c. voltage and normal direct current is flowing through its circuit, it is very sensitive to changes in voltage across its terminals; therefore, if the alternating current output from the W. E. 8-B amplifier is applied across the aeo-light terminals, it causes the brilliancy of the glow within the tube to vary in accordance with variations in the applied sound energy.

The aeo-light is placed in a tube in the back of the motion-picture camera, the inner end of which tube has a minute slit, about 100 millimeters long and 1 millimeter wide, and it is through this little slit that light shines from the aeo-light through to the film, which is passing the aperture in the end of the aeo-light tube at the rate of 90 feet per minute during the course of operation.

D. SYNCHRONIZATION.

In the Fox-Case Movietone system of recording sound pictures the action being recorded by the camera always bears a constant relation to the sound being recorded, because in this system the sound is recorded on the same negative that the picture exposures are made on and they are, therefore, always in synchronism. The action is recorded at the front of the camera and the sound is recorded at the back of the camera through the medium of the aeo-light, which is inserted through a tube in the back.

Radio Telephone Equipment Is Used for Railway Communication

(Continued from page 108)

the radio transmitter power unit. Then when the small push-button on the handle of the microphone is depressed the equipment is ready for talking.

The equipment mounted on the tender is shown in Fig. 4. The larger of the two metal boxes which are mounted close together contains the transmitter-receiver unit, while the smaller box contains the power unit. Both of these boxes are substantially constructed to withstand severe blows and a double seal is used on the cover to exclude moisture, water or snow from the apparatus inside. The antenna consists of a heavy iron pipe mounted around the outer deck of the tender. This pipe is supported on heavy Micalox posts, making a very substantial installation entirely in keeping with steam locomotive construction.

Tell 'Em You Saw It in the Citizens Radio Call Book Magazine and Scientific Digest

Spring Suspension Used

The receiver-transmitter assembly with spring mounting is shown in Fig. 5. The vacuum tubes extend above the top of the panel in order to provide sufficient ventilation for them. At the same time they are protected by means of a perforated metal cover. A system of snubbers, not shown in the photograph, is also provided with the transmitter-receiver assembly. Experience has shown that the type of suspension adopted permits the apparatus successfully to withstand severe shocks as well as the normal vibration without any danger to the unit in the assembly.

Installation of the transmitter-receiver is made in one of the lockers of the caboose. The same type of spring suspension is used for the unit employed on the locomotive end. Control unit mounted above the conductor's desk in the caboose is shown in Fig. 3. This unit performs the same function and is operated in the same manner as that in the locomotive cab. A small switch for turning on or off the entire equipment which may be locked in off position is provided on the control unit. This prevents unauthorized persons from operating the apparatus. The loud speaker mounted near the top of the caboose roof is shown in Fig. 6. This is the same type of speaker as used in the locomotive and is so mounted that the sound is directed towards the conductor's desk.

Changing Electrical Energy Into Sound Is Interesting Step

(Continued from page 100)

ances, the amount that a part may vary from the standard, are small and the inspectors strict. Everything is precise, regulated, carefully adjusted so that parts are finished with hair-splitting accuracy. It is not merely pride that enforces this high class workmanship, it is necessity. A radio speaker is a delicate, complicated piece of apparatus and to function perfectly, even after years of hard service, watchlike precision must be maintained.

After the machine shop comes the spraying room. All the metal parts must be carefully cleaned of every vestige of grease and dirt, dried, and sprayed with a durable enamel. The pieces that must be handled a great deal and must be finished with precision are electro-plated with a thin, tough, rust-proof finish.

In another room, the paper cones are cut. A special paper is used. For the speaker to be free from any rattles, and to be sensitive, this cone material must be very strong and still very light. This special paper combines these things admirably. It is very strong, which provides a large factor of safety against rattles, while forming a very light, thin diaphragm. In the same room, the cone flanges are cut from high grade, flexible leather. These are glued to the edge of the cone and hold the outer edge of the cone in position without retarding the motion. A special gluing machine applies the glue to fasten the two parts and insures a tight, lasting joint.

Moving Coil Is Delicate

Next we move to the room where the moving coils are made. This is the most delicate part of the entire instrument. As with the cones, these must be very light and very strong. Special jigs have been made to make these coils. One machine winds paper strips into coil frames. Another winds the wire. The next trims the ends to the precise size. Another to smooth the ends. The next to fasten the leads.

This is the part that undergoes the most rigid inspection of all. The size is carefully gauged, the roundness is tested, the number of turns is accurately measured, conductivity, in-

THE TECHNICAL DEPARTMENTS OF

80%
OF THE GREAT RADIO MANUFACTURERS SPECIFY
POLYMET PRODUCTS

Emphasizes the "INSIDE" as well as the "OUTSIDE"

APPROVED CONSOLE 55

An important consideration toward the success of this set was made by the Polymet Manufacturing Corporation, makers of dependable and modern essential radio parts—a consideration that clinched this instrument in Stewart-Wasson's opinion. "Stewart-Wasson's Earrier sets that are well known for their quality cannot be made without quality parts."

Polymet Products make the difference! Stewart-Wasson Corporation, 1000 Broadway, New York City, N. Y.

the technical departments of 80% of the great radio manufacturers specify Polymet Products for their sets.

POLYMET MANUFACTURING CORPORATION

This statement appeared in our Saturday Evening Post advertising. The publishers investigated its truth before we could use it. We were glad they did for now you can know that "80% equip with Polymet" is not so many words, but so much fact.

Doesn't such overwhelming endorsement of

POLYMET

Radio Set Essentials speak for itself?

Use the Quality Parts used by the Industry—

- Polymet Filter Blocks . . . Transformers . . .*
- Mica Condensers . . . Resistors . . . Coil Windings*
- . . . By-Pass Condensers . . . Plugs and Connectors*

POLYMET MANUFACTURING CORP.
839-B East 134th St., New York City

Tell 'Em You Saw It in the Citizens Radio Call Book Magazine and Scientific Digest

Like a Car with a Balked Gas Lever—in heavy traffic

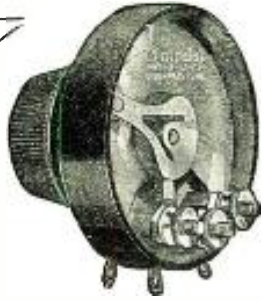

Your foot on the gas brings a jerky response . . . you're holding up traffic that's anxious to move.

Your variable resistance feeds the "gas" to your radio receiver . . . and there's all the difference in the world if it's a CENTRALAB.

Quiet, even flow of current without a crackle or a sputter . . . that's CENTRALAB performance. . . . a scientifically constructed precision control for the modern radio receiver.

Write for Free Booklet on "Volume Controls and Voltage Controls—Their Uses"

Centralab

CENTRAL RADIO LABORATORIES
20 Keefe Avenue Milwaukee, Wis.

Remarkable!

In dignified beauty within and without—in luxurious comfort—THE DRAKE rightfully takes its place among the great hotels. In location it surpasses them all. Here the sun-swept waves of blue Lake Michigan invite your gaze; yet a few minutes' exhilarating walk and you are in the midst of the sights and sounds and surging movement of Chicago's world-famous Loop. Rates as low as \$5.00 a day single room with bath; \$6.00 double. The ideal year 'round home—special discounts for extended stays. Write for Illustrated Booklet, Edition 23.

Under the Blackstone management
the world's standard in hotel service



Lake Shore
Drive and
Michigan Avenue

HOTEL
CHICAGO

sulation, strength, tightness, are all checked to insure good performance and long life.

Now we have watched all the parts being made. The next step is assembly. This is the room where the separate parts flow together and form a complete speaker. Assembly is done in two parts. The first step assembles the cone housing, the cone, the movable coil, and the core into a complete cone-head. The other assembly subdivision is the magnetic structure, the speaker base, the input transformer, and the rectifying system to transform alternating current to direct current for the electro-magnetic field when the speaker is to be used with the alternating house current.

Jigs are used everywhere. The entire cone head assembly is done in one machine that holds the parts in correct relation and enables the operators to complete the sub-assembly without removing the housing from this single master jig.

The final assembly, that of attaching the cone head to the magnetic structure and the base is very simple, due to the superior design of the Magnavox speakers. Three screws do the work. None of these are adjustments, all they do is to hold the parts together.

Testing Is Final Step

Next we move to the testing department. This is the final step and the one that provides the final check on all the work. A large amplifier, amplifying phonograph music provides the testing medium. With the aid of a throw-over switch, the speaker on test is compared against a standard. By using this testing method, the speakers are tested under actual operating conditions. Any flaw is always detected here if, by some chance, it could have slipped by the sub-assembly inspections.

All that remains to be done is to pack and ship. As an extra precaution, the units are wrapped, and securely fastened in strong wooden boxes.

Now we have finished our inspection. We have seen the raw material enter, seen it take shape, seen it combined, seen it tested until it finally emerged as radio loud speakers.

Radio Engineering Department

(Continued from page 76)

$$\text{or } .0002 \text{ amperes. } \frac{120 \text{ volts}}{.0002 \text{ amperes}} = 600,000 \text{ ohms.}$$

The neon tube will last many months in service if the limiting resistor R_1 is of such value that the starting current is limited to 2,000 microamperes.

The resistance of the neon lamp at 2,000 microamperes is 134.5 volts

$$\frac{134.5 \text{ volts}}{.002 \text{ amperes}} = 67,250 \text{ ohms. The values of voltage and}$$

current being taken from the curve. If the high voltage source (Fig. 7) is 1,000 volts, then under starting condition before the condenser is charged, the total resistance of R_1 in series with R_2 and the neon lamp must be 500,000 ohms to limit the current to .002 amperes or 2,000 microamperes. Total resist-

$$\text{ance, starting condition } R = 500,000 = R_1 + \frac{(R_2 \times 67250)}{(67250 + R_2)}$$

Now R_2 must be of such value that the sensitivity of the apparatus is not seriously affected. Any current by-passed by the resistor R_2 does not flow through the lamp. The maximum resistance that the lamp reaches while there is still a visible glow is about 1,190,000 ohms, while the current is 100 microamperes (from curve Figure 6). The ratio of the total current through the parallel circuit (lamp and R_2) to the current through the lamp determines the sensitivity. We can decrease the sensitivity of the lamp 30 per cent and still leave the resistance R_2 small enough to stabilize the operation of the

Tell 'Em You Saw It in the Citizens Radio Call Book Magazine and Scientific Digest

lamp. Then with 130 microamps through the parallel circuit at 119 volts, the resistance of the parallel circuit will be 119 volts

$$\frac{000130 \text{ amps}}{119 \text{ volts}} = 916,000 \text{ ohms}$$

000130 amps

$$916,000 = \frac{R_2 \times 1,190,000}{R_2 + 1,190,000} \text{ solving for } R_2 \text{ we find}$$

$R_2 = 3,980,000$ ohms. Approximately 4 meg. Now we can substitute the value for R_2 into the equation for the starting condition and solve for R_1 . Using the approximate value for R_2

$$R = 500,000 = R_1 + \frac{4,000,000 \times 67,250}{67,250 + 4,000,000}$$

$$R = 500,000 - 66,000 \text{ approx.} = 434,000 \text{ ohms.}$$

Then in Fig. 1 $R_1 = 434,000$ ohms

$$R_2 = 4,000,000 \text{ ohms (4 megs.)}$$

On the production line one such combination of resistors and lamp is used in series with each tap of the condenser bank, to cut down the time necessary for the test, and to indicate the tap which is broken down or is leaky. The condenser bank is set in a jig, which makes contact with each terminal and applies the voltage to each terminal through a separate lamp with its associated resistances. Each lamp lights indicating that each tap is making contact and that the condenser is charging. If all taps are connected to perfect condensers, each lamp ceases to glow when the bank is charged, or when charging current becomes less than 130 microamperes. If there is a breakdown or leak the lamp continues to glow, which is connected to the tap for that condenser. If any lamp does not light the condensers are not connected to the tap due to open circuit.

Charging Cycle

The cycle of time required for the condensers to charge, depends on the number of condensers connected to any single tap, the time for three microfarads, being less than four seconds.

This test set is used in the production line as the last test before the condenser bank is assembled in the power unit, as a follow-up on the regular breakdown tests. It takes out those condensers which have broken down and self healed, those which are leaky, and breaks down condensers which are weakened by the previous tests. The condensers which break down on this test set can readily be examined in the laboratory because the puncture is not ruptured and blackened over a wide area as they are on the regular type of equipment. All in all, it acts as a monitor of the product and does not turn out merchandise which is injured by testing.

Four Screen Grid Stages Used in National MB 29 Receiver

(Continued from page 50)

with the use of a single transformer for this purpose. Both the plate and filament transformers are wound with wire much heavier than generally customary, in order to supply A and B voltages for any r. f. amplifier-tuner with which the amplifier may at any time be used.

Because of the high capacity of the Mershon condenser, a single filter section is ample for the push-pull stage. Another section is then added for the first stage plate supply as well as the external voltage taps (all of which should be operated as near hum-free as possible, if there is to be no hum in the loud speaker). A circuit novelty which works out exceedingly well is interposed at this point; it is the manner of connecting the third section of the Mershon condenser so that it provides exceedingly effective by-passing and tank-capacity service for the first audio stage, in addition to its filtering action. Thus,

Thordarson Transformers and Chokes

For Use With

"245" Type Power Tubes and "224" Screen Grid Power Detectors



Input Couplings

Single "245" tube, from any radio amplifying tube, use any one of three transformers..... (R-400 especially suited to "226" and "227" tubes)	R-260 R-300 R-400	\$5.00 8.00 9.00
Push-Pull "245" tube, from any audio amplifying tube. Use 1-to-1 ratio input transformer.....	T-2408	\$8.00
Use 2-to-1 ratio input transformer.....	T-2922	12.00
Screen grid power detector "224" to any single power tube, use "Autoformer" for choke-resistance type of standard circuit.....	R-190	\$5.00
Screen grid power detector "224" to any push-pull power tubes use R-190 Autoformer for parallel feed to detector plate and 2-to-1 coupling transformer.....	T-2922	\$12.00

Speaker Couplings

Single "245" tube to dynamic speaker with built-in transformer, to cone speaker, or to magnetic speaker—Use either one of two transformers.....	T-2876 T-2901	\$ 6.00 12.00
Use choke-condenser coupling, employing one choke.....	R-196	5.00
Single "245" tube to moving coil of dynamic speaker—Use transformer.....	T-2902	\$12.00
Push-pull "245" tubes to dynamic speaker with built-in transformer, to cone speaker, or to magnetic speaker—Use coupling transformer.....	T-2880	\$12.00
Use choke coupling, employing double choke.....	T-2420	8.00
Push-pull "245" tubes to moving coil of dynamic speaker—Use either one of two transformers.....	T-2629 T-2903	\$10.00 12.00

Filament Supplies

For six "224" screen grid tubes or six "227" tubes—Use filament transformer (10.5 amps at 2.5 volts).....	T-3660	\$9.00
For two "224" tubes or two "227" tubes and one or two "226" tubes use double voltage transformer.....	T-3081	\$6.00

Power Compacts

For filament current, plate current and bias on "245" push-pull power stage, also plate current for set. Contains filter chokes. Uses one 280 rectifier tube.....	R-245	\$24.00
For filament current, plate current and grid bias on single "245" power tube and one "226" audio tube, also plate current for set. (Requires extra T-3081 filament transformer.) Contains filter chokes.....	R-480	\$17.00

THORDARSON RADIO TRANSFORMERS

Thordarson Electric Manufacturing Co.

Transformer Specialists Since 1895

WORLD'S OLDEST AND LARGEST EXCLUSIVE TRANSFORMER MAKERS

Huron and Kingsbury Streets, Chicago, Ill., U.S.A.

Tell 'Em You Saw It in the Citizens Radio Call Book Magazine and Scientific Digest

FREE!!

with a year's subscrip- tion to the Citizens Radio Call Book Magazine



The Famous WARD needs no introduction. Heating Elements will not burn out; either A. C. or D. C., 110-115 volts draws 100 watts. Six feet of heater cord, standard 2-piece separable plug, ebony finish handle, brass plated barrel, $\frac{3}{8}$ -in. diamond-shaped tip, temperature 500 degrees maintained, handle remains cool. Handle insulated against possible short. A genuine high-grade electric iron. Lava rock core approved and listed as standard by Underwriters' Laboratories.

**A most useful household article.
Can be used to solder anything
that requires soldering**

Send in the coupon below and receive the iron absolutely free with a year's subscription to the Citizens Radio Call Book Magazine—for only \$1.75. Hurry—this offer is limited—mail coupon today.

**Iron Is Guaranteed by Manufacturer for
One Year—Hurry—This Offer
Is Limited**

Citizens Radio Service Bureau
508 So. Dearborn Street, Chicago, Ill.

Here's my \$1.75 (Foreign \$2.00), for which please send me a Ward Electric Soldering Iron free and enter my subscription for the Citizens Radio Call Book Magazine for one year starting with the

Sept. Nov. Jan. March issue.

Name.....

Street and Number.....

City.....State.....

both the push-pull stage and the input stage have their own independent tank condensers.

Lining Up Condensers

After the set is completely assembled and wired, all that it is necessary to do is to line up the condensers for maximum reception at the lower end of the dial by means of the trimmers to compensate for differences in capacity due to the wiring. Connect the set to a short antenna, say 20 feet long, and tune in some weak station on the low wave lengths. Should the set tend to oscillate, change the screen grid tubes around, as the a. c. screen grid tubes which are at present available are not as uniform in their characteristics as the more widely used 201-A. If there is only a slight tendency to oscillate, this may be eliminated by slightly decreasing the volume control. The lined up condensers should then be slightly adjusted so that the weak station comes in the loudest or nearly so, and the receiver should then tune sharply all over the dial and have a tremendous amount of gain.

Official Parts List

The National MB 29 kit comprises the following:

- 1 National chassis with five tube sockets
- 4 National r. f. choke coils
- 3 1.0 mfd condensers
- R-3 1,800 ohm resistor
- R-4 100 ohm resistor
- R-2 60 ohm resistor
- R-1 50,000 ohm variable resistor, special taper
- R-5 20,000 ohm resistor
- 4 National special r. f. transformers complete with self-contained by-pass condensers and r. f. choke coils
- 4 National type M variable condensers with zero adjustments
- 1 National type H drum dial
- 1 .001 mfd mica by-pass condenser
- 2 Binding posts with insulating washers
- 1 Pkg. Corwico Braidite hookup wire
- 4 Triad. Arcturus or Cunningham 221 tubes
- 1 Triad, Arcturus or Cunningham 227 tube

S-M 712 Band Selector Tuner Now Goes in Class With Supers

(Continued from page 54)

- 1—Yaxley 840C 40 ohm center tapped resistor
- 1—Durham 10,000 ohm two-watt (green) resistor
- 1—Durham 60,000 ohm one-watt (blue) resistor
- 2—Polymet .00015 small moulded condensers
- 3—Carter RU-400 400 ohm resistors
- 1—H. & H. 1561 on-off switch
- 2—KK 817 $1\frac{1}{8}$ -in. brown wood knobs
- 1—KK 816 $1\frac{3}{8}$ -in. brown wood knob
- 8—Moulded binding posts
- 1—Set of hardware and hook-up wire

ABC of Radio Department

(Continued from page 103)

heated die, and extrudes a hair-like filament which is then pulled along and wound on a large reel similar to a bicycle wheel with the tire removed. Because of the fine diameter and flexibility of the glass thread, it does not break even when considerably bent.

Subsequently, the glass filament is transferred to a coating machine in which the glass thread is first passed through an alcohol bath then rubber and polished by cloth pads, followed by the coating and the electric furnace with a gaseous atmosphere. The colloidal coating forms a tough, positive and indestructible conductor of minute thickness about the glass thread. The resistance per unit length is continuously checked

Tell 'Em You Saw It in the Citizens Radio Call Book Magazine and Scientific Digest

up during coating. Finally, the filament is broken into 12-inch lengths and placed in large glass tubes.

Mississippi Valley Has Two Models of A. C. Screen Grid Supers

(Continued from page 66)

Such units can be readily connected to the Braxton-King Type B tuner, giving the owner at moderate cost a highly engineered one dial a. c. screen grid super. Most of these power amplifiers are electrically operated throughout, while others have the first stage operating from storage battery and the second stage from a. c. In this case, the first stage can be easily re-wired to take a 227 tube, the filament supply being taken from the 2½-volt filament transformer on the model B tuner.

Jewell Has Service Data

(Continued from page 86)

are printing herewith extracts covering Radiolas as shown in the Jewell manual.

RADIOLA—Model 30A

Note: For "A" volt tests adjust controls on panel so that reading on first tube tested is that shown. This gives an average condition of operation and a margin of safety in all tests.

Readings Plug in Socket of Set—
Tube in Tester

Tube No.	Type of tube	Position of Tube 1st R.F. det., etc.	Tube Out			Cathode	Plate	N'rm'l M.A. Test	Plate Grid M.A. Test	Plate M.A. Ch'ge
			A Volts	B Volts	A Volts					
1	199	1st Det.	6.5	47	3.2	26	7
2	199	1st I. F.	6.7	73	2.9	72	7	2	3
3	199	Tuned R. F.	76	3.4	74	7	2	3
4	199	2nd I. F.	80	2.9	84	7	2	3
5	199	Oscillator	80	3.0	79	7	2.6	4.2
6	199	2nd Det.	38	2.9	38	2	1.4	0
7	199	1st A. F.	8.6	2.9	74	7	2.4	3.6
8	171	Power Amp.	5.5	2.10	43	16	24
9	281	Rectifier	7	45
10	281	Rectifier	7	45

RADIOLA—Model 32

Readings are approximately the same as on model 30A except a 210 power tube is used in last A. F. stage and 2—281 rectifier tubes are used. These three tubes operate on a filament voltage of 7. The plate voltage of the 210 tube is 425 volts, normal milliamperes 22, grid test 42, indicating a change of 20 M. A. The output of rectifier tubes is approximately 60 M. A. each.

RADIOLA—Model 60

Readings Plug in Socket of Set—
Tube in Tester

Tube No.	Type of tube	Position of Tube 1st R.F. det., etc.	Tube Out			Cathode	Plate	N'rm'l M.A. Test	Plate Grid M.A. Test	Plate M.A. Ch'ge
			A Volts	B Volts	A Volts					
1	227	Ant. Coup.	2.35	148	2.2	144	18.0	25	1.0	3.0
2	227	1st R. F.	2.35	148	2.2	144	18.0	25	1.0	3.0
3	227	1st Det.	2.35	84	2.2	70	9.0	0	1.0	3.0
4	227	1st I. F.	2.35	148	2.2	144	18.0	25	1.0	4.0
5	227	2nd I. F.	2.35	148	2.2	144	18.0	25	1.0	4.0
6	227	Oscillator	2.35	118	2.2	70	0.0	0	7.0	7.0
7	227	2nd Det.	2.35	162	2.2	157	18.0	0	1.0	3.0
8	171A	1st Audio.	5.00	178	4.8	157	31.5	15.0	17.0
9	280	Rectifier	5.00	4.8	19.0
10

Note: The above readings were taken with a line voltage of 117 volts. The volume control should be set centrally with the line vertical in order to get the above readings. The "C" voltage on tubes 1, 2, 4 and 5 will vary from 9 to 27 volts, depending on the position of this volume control, hence these readings are taken at the middle point.

RADIOLA—Model 64

Line Voltage 112—Volume Control Full

Readings Plug in Socket of Set—
Tube in Tester

Tube No.	Type of tube	Position of Tube 1st R.F. det., etc.	Tube Out			Cathode	Plate	N'rm'l M.A. Test	Plate Grid M.A. Test	Plate M.A. Ch'ge
			A Volts	B Volts	A Volts					
1	227	Ant. Coup. St.	2.5	128	2.4	124	25	13.5	3.4	7.8
2	227	Tuned R. F.	2.5	128	2.4	124	25	16.0	3.3	7.1
3	227	Tuned 1st Det.	2.5	80	2.4	75	25	16.0	0.2	2.9
4	227	1st I. F.	2.5	128	2.4	124	9	13.5	3.4	7.8
5	227	2nd I. F.	2.5	128	2.4	124	9	13.5	3.4	7.8
6	227	Oscillator	2.5	80	2.4	75	25	13.5	7.0	7.6
7	227	2nd Det.	2.5	180	2.4	176	25	13.5
8	227	Vol. Control	2.5	80	2.4	75	4
9	250	Power	7.5	584	7.2	392	65	52	55
10	281	Rectifier	7.4	50
11	281	Rectifier	7.4	50

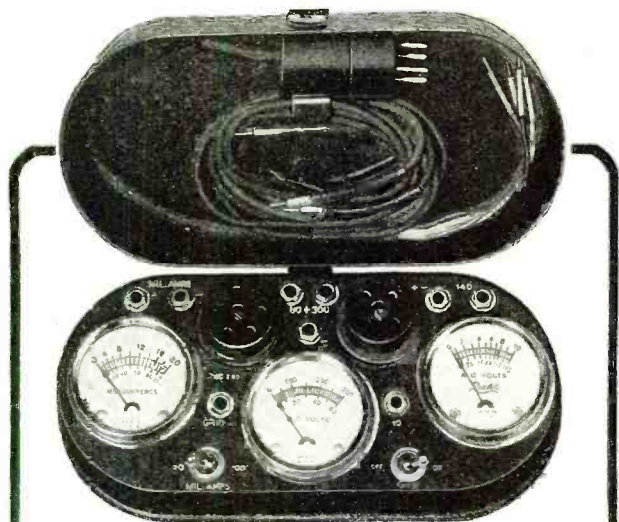

Readrite

Model 245

SET AND TUBE TESTER

List Price \$20

Tests Screen-Grid

A SUPERB new model especially designed for A sets using the 245 power tube. Simple to use. Easy to carry. Supremely practical. Extra cords with tip jack connections, permit use of each meter individually. Checks line voltage.

Self contained. Seamless drawn metal cover with leather handle. Beautiful baked enamel finish. Rugged. Compact. Accurate. Unique. An outstanding value. It is sure to please you.

NET TO DEALER

\$12



READRITE METER WORKS
Est. 1904
10 COLLEGE AVE. BLUFFTON, OHIO

Tell 'Em You Saw It in the Citizens Radio Call Book Magazine and Scientific Digest

Let us
Welcome you
to DETROIT



Hotel FORT SHELBY

HOTEL Fort Shelby offers the dual advantage of a hushed, peaceful environment . . . and immediate proximity to the financial, theatrical and shopping centers of downtown Detroit. With its new 22 story addition, equipped with the most modern comforts and appointments (including Servidors) 900 attractive rooms are available to our guests.

Whether your choice be one of the many very comfortable rooms at \$3 or \$4 a day, or one of the richly furnished suites with an enchanting view of city, river and Canadian shore, you will enjoy a special sense of value at this hotel. At your request (by letter or wire), we'll reserve tickets to theaters, concerts and sporting events.

Look for the large green sign atop the 22nd floor. Write for direct motor route to the hotel. Attendants promptly take care of arriving cars.

J. E. FRAWLEY, *Managing Director*
**Lafayette and First
DETROIT**

Improved Leutz "Seven Seas" Console Has Phonograph Combination

(Continued from page 109)

audio amplifier transformer, namely, the parallel plate feed. The detector plate is fed through a high impedance choke and resistor in parallel, and the primary of the audio transformer is coupled to the plate through a blocking condenser. The blocking condenser blocks the plate current but passes the audio currents which are the only ones required in the primary of the audio transformer. Otherwise, if the detector plate current were allowed to pass through the primary of the audio transformer with its high-grade iron core, the core would become permanently magnetized to an extent that would cause distortion with age. Eventually, the transformer would become useless. The same system is also employed in coupling the first audio plate to the primary of the push-pull input transformer. An additional advantage of this system is that the direct current component cannot interfere with or distort the audio currents.

Self-Healing Condensers Used

The power plant of the "Seven Seas" console employs two 281 rectifiers for full-wave rectification, together with a high-grade filter circuit. Self-healing filter condensers are employed, so that if any condenser is ruptured by an abnormally high surge, this breakdown will automatically heal again and the condenser can continue in satisfactory service. The dynamic speaker field is included in the filter circuit, serving as a choke, instead of utilizing crudely rectified a. c. as in many present-day sets.

In the new "Seven Seas" console model, the single-control tuning feature is retained, in the form of a split drum which may be tuned as a single unit or, for exceptionally weak signals, may be worked as two units for utmost precision in

tuning. Whereas the 250 power tubes were optional in the former model, they are standard equipment in the new model.

Twelve-Inch Dynamic

Two features, previously confined to sets of much higher price, are now included in the new model. The first is a 12-inch dynamic built-in loud-speaker of sufficient capacity to handle any volume with true tone and total lack of distortion. The second and most desirable feature is the incorporation of a high-grade electrical phonograph, built into a drawer in the bottom of the cabinet. The presence of this electric phonograph feature would never be suspected, for the drawer, when closed, is flush with the front of the cabinet, which resembles the classic radio console in every way. The phonograph feature includes an electric turntable motor with speed regulator and automatic governor, as well as a balanced pick-up, a scratch filter, and a volume control. A simple switch throws the amplifier system from "Radio" to "Phonograph," and no external wires or adapters are required. The tone quality of electrically reproduced records, taking advantage of the improved audio amplifier with two 250 power tubes in push-pull and the giant 12-inch dynamic speaker, is quite remarkable and on a par with the reproduction of sound pictures in the better class theatres.

For those who do not desire the phonograph feature, the "Seven Seas" console is available in the new model without phonograph, including the same 12-inch dynamic, the 250 power amplifier, the adjustable selectivity device, front panel illumination, volume control, and so on.

The illumination of the new model is another advanced feature. The old-fashioned brilliant pilot light has been eliminated. It is now replaced by a special form of indirect illumination that bathes the entire operating part of the console with a soft glow, and no direct light source is visible. The cabinet console is made of selected walnut, with all locked

3-STAGE BAND FILTER and R. F. AMPLIFIER UNITS



completely wired, shielded and tested. Band Filter for 10-kilocycle selectivity. Flat-top tuning without side-band cutting. R. F. Amplifier with amazing amplification of 3 Screen-Grid tubes. Both units complete in every detail, except tubes, for immediate installation.

completely wired, shielded and tested. Band Filter for 10-kilocycle selectivity. Flat-top tuning without side-band cutting. R. F. Amplifier with amazing amplification of 3 Screen-Grid tubes. Both units complete in every detail, except tubes, for immediate installation.

SHIELDED POLARIZED R. F. CHOKE



A radio-frequency choke specially developed for modern high-gain shield-grid receivers. Aluminum-shielded and polarized. Minimum external field. No undesired coupling to cause circuit instability or feed-back. High inductance, low distributed capacity. Efficient, compact. Sub-panel connections.

New DRUM DIAL PANEL PLATE



Richly embossed, pebbled bronze, in the modern mode. It has grace and charm appropriate to the superb dial mechanism back-panel, that delighted thousands of set builders last season. The control knob can be mounted anywhere on the panel. Illuminated scale.

NEW!
Members of the Famous
HAMMARLUND
RADIO FAMILY

Each year, as Hammarlund facilities grow and Hammarlund reputation for quality is more firmly entrenched, new aids to the radio builder are presented. Here are five of Hammarlund's latest perfected devices, in addition to the famous "Midline" Condenser, which has never been surpassed since its introduction more than three years ago. The Hammarlund policy of progressive conservatism is your assurance of scientific accuracy and finest workmanship in any product bearing the Hammarlund imprint.



Write Dept. CB11 for folders

HAMMARLUND MANUFACTURING CO.
424-438 W. 33rd Street, New York

AUDIO TRANSFORMERS Including PUSH-PULL

Designed for fidelity of response over the audible frequency range with a sharp cut-off at the high frequency noise level. Large cross-section core of specially treated laminations permits high primary currents without saturation. Completely shielded. Pictorial terminal leads for sub-panel connection.



SCREEN-GRID TUBE SHIELD

Essential for '22 and '24 type shield-grid tubes to insure full advantage of their great amplification. Aluminum, with a soft rubber grommet at top to protect control grid outlet. Designed for use with sub-panel sockets. Mounting screws and control grid connector included with each shield.



The Famous "MIDLINE" CONDENSER

More than three years the favorite of engineers and advanced radio fans—and still new in the sense that its features and workmanship from the beginning were so far ahead that its popularity has steadily increased and its leadership still stands unchallenged. All standard capacities.

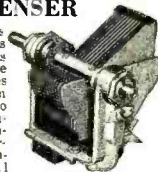

joints, and the exterior is beautifully finished with matched grain. The design is attractive yet conservative, insuring permanency of style.

The new "Seven Seas" console is regularly supplied for 110-volt, 60-cycle alternating current, but on special order it may be supplied for any other alternating current supply. Also, it can be operated on direct current supply, by means of a small motor-generator set.

Screen Grid Tuned R. F. Used in Pilot Super-Wasp S. W. Set

(Continued from page 64)

- sockets (for 222 and detector tubes).
- 2—No. 213 four-prong sockets (for audio tubes).
- 2—Pairs grid-leak clips.
- 1—No. 758 3-megohm grid leak.
- 1—No. 750 100,000-ohm grid leak.
- 1—No. 50B fixed condenser, .0001 mf.
- 1—No. 130 r. f. choke coil.
- 5—No. 59 fixed condensers, .01 mf.
- 2—Sets of plug-in coils, made especially for the Super-Wasp: Nos. 601A and 601D.
- 4—Packages of hardware, including thirteen binding posts, ten sets of insulating bushings for them, four lengths of spaghetti tubing, 12 feet of tinned copper wire, all necessary nuts, bolts and washers, Mueller clip for connection to screen-grid tube, and six special double-end lugs for mounting of fixed condensers.

Library Needs Old Copies

WE are advised by the director of the New York Public Library, 5th Avenue and 42nd Street, New York City, N. Y., that they are in need of all numbers of Volumes 1 to 7 inclusive in order to complete their files.

Inasmuch as these numbers are now out of print at this office, the only possible manner in which the library would complete its files would be through the generosity of some of our readers who may have certain volumes which they no longer care to retain. We feel sure the New York Public Library would be very grateful for any such additions to their files.—Editor.

"Please Stand By For Station Announcement"

(Continued from page 118)

of the hit-or-miss announcing or extemporaneous time killing has been passed for some time as far as the chain systems are concerned. These forms of announcement may be perfectly legitimate for the individual stations in their local relations, but when an advertiser is paying big money for time on the air, it is only natural that everything shall be worked out so that clocklike precision and accuracy shall be obtained. In striving for this, of course, the average listener has been considered, since he is the one who might tire easiest with a bore-some or disjointed program.

With two large chains in existence, such as the National Broadcasting System and the Columbia Broadcasting Co., the listener in every quarter of the country is assured of ample entertainment of a high grade type. There is no limit to the choice of program awaiting the listener. All he has to do is turn on the set and select the one that pleases him most.

YOUR RADIO CAN BE ONLY AS GOOD AS ITS SPEAKER

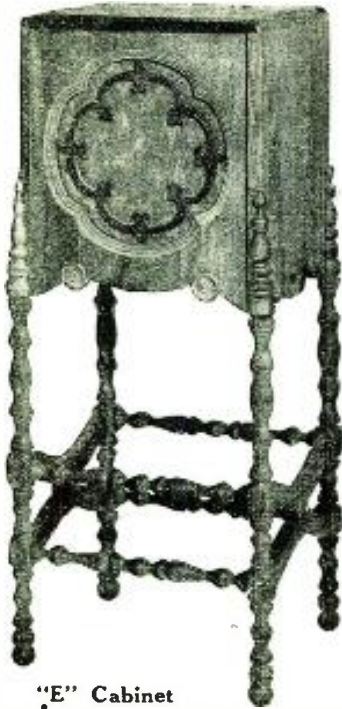

"E" Cabinet
Small Console Model

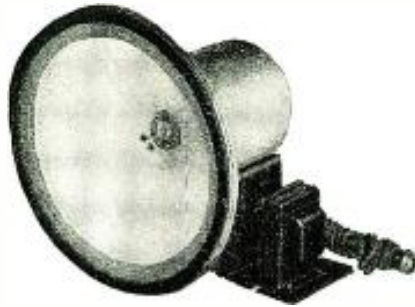

"D" Cabinet
Table Model

"The Speaker of the Year"

**PERFECT YOUR RECEPTION WITH
A WRIGHT-DeCOSTER REPRODUCER**

*Write Department "K" for descriptive folder of chassis
and different cabinet models*

WRIGHT-DeCOSTER, Inc.



ST. PAUL, MINNESOTA

Aero Announces "Overseas Four" All Electric Short Wave Set

(Continued from page 58)

the coil you wish for the wave band desired. For example: If one wishes to receive a station on 245 meters, coil No. 2 may be used and the tuning dial set for about 62 to 65 degrees. Turn the volume control slowly to the left. After it has been turned about one-half way around a hissing sound will be heard. This indicates the receiver is oscillating. It is thus brought to a point where best voice and music reception is obtained.

This issue of the magazine as well as other issues contain up-to-date data on short wave broadcast stations so that the average user will find plenty of entertainment with which to pass away the time. A log of the set may be readily made up so that it will always be easy to turn to a given broadcast station.

"HI-Q 30" Model Uses a Band Filter and 3 Tuned R. F. Stages

(Continued from page 52)

do so. The indicator drum should then be centered with the escutcheon aperture and rotated until the 100 mark is exactly even with the indicating points and its set screw tightened.

The tubes should be placed in their respective sockets, the shields placed over the screen grid tubes and the connectors placed over their control grid caps.

After setting the "on" and "off" switch on the panel to the

"off" position, the receiver may be connected to the 110 V. 60 cycle line using the silk cord with its connectors provided with the parts. The duplex receptacle is for the purpose of providing 110 volts a. c. for operation of a 110 volt a. c. dynamic speaker and a 110 volt a. c. phonograph motor. This permits the use of but one cord between the receiver cabinet and the wall outlet. This duplex receptacle is wired in such a manner that the a. c. current to both the speaker and the phonograph motor is controlled by the main switch on the set panel.

Connect the loud speaker and the antenna and ground wires. The "on" and "off" switch may now be turned on and if all connections have been made correctly the filament of the 280 and 245 tubes should slowly come to a red glow. The heater filaments of the 224's and 227's should glow brightly. If one of the tubes fails to light it may be tried in another socket *of the same number*. It would be well, however, to use a set of tested tubes. If a tested tube fails to light a careful check of the connections to its socket will reveal the trouble.

Assuming that all tubes light properly advance the volume control to the half or three-quarters point and rotate the tuning dial slowly until a station is heard. Then alternately reduce the volume control and readjust the tuning dial until the best tuning adjustment is secured.

Although all possible matching adjustments have been made at the factory, the final adjustment of the six equalizers can only be made after the receiver is in actual operation. One of these equalizers is connected across each section of the two triple gang condensers. In adjusting them a wooden or other insulated screw-driver is convenient.

Preliminary synchronizing may now be accomplished by adjusting each equalizing condenser for loudest signal. It is extremely important that the value be kept at a low point dur-

Tell 'Em You Saw It in the Citizens Radio Call Book Magazine and Scientific Digest

KOLSTER



Kolster Model K-45 using Electric Tuning and Remote Control and housed in a cabinet of extraordinary beauty.

... another leader who standardizes on DURHAM Resistors and Powerohms

KOLSTER!—another great name in radio—another great leader who has set the pace in quality receivers for many years—another leader who has long recognized the superiority of the metallized principle upon which DURHAM Resistors and Powerohms are manufactured. Yes, KOLSTER is another of America's quality receivers which standardizes on Durham resistance units . . . because they are absolutely unfailling both in accuracy and uniformity. DURHAMS may cost a slight fraction more than average resistances, but their aid to quality reception is well worth the slight difference in price. Furthermore, their presence in a receiver is a guide to the quality of other parts. Write for engineering data sheets, samples for testing and complete literature. Please state ratings in which you are interested.

DURHAM Metallized RESISTORS and POWEROHMS are available for every practical resistance purpose in radio and television circuits. 500 to 200,000 ohms in power types; 1 to 100 Megohms in resistor types; ratings for all limited power requirements; standard, pigtail or special tips.



DURHAM

METALLIZED

RESISTORS and POWEROHMS

INTERNATIONAL RESISTANCE CO., 2006 Chestnut St., Philadelphia, Pa.

ing these adjustments, as otherwise a false setting may be made.

Final Balancing

When this adjustment has been completed the receiver will be found to track fairly well and the final adjustment may now be made by tuning in a weak station at around five or ten on the dial, and carefully resetting each equalizer for loudest signal, taking care to keep the volume control as low as possible. Theoretically, adjustment of the equalizers can be accomplished most accurately at the lowest broadcast wavelength, that is at 200 meters, which should be received with the dial at 5 degrees.

Operation of Set

On account of the three stage input filter or pre-selector used in the Hi-Q-30 the length of the antenna used does not have a very marked effect on the selectivity of the receiver. There are two antenna binding posts, one for a long and one for a short antenna. In general a long antenna may be considered as one having an overall length, including lead-in, of seventy-five feet or more, and such an antenna should normally be connected to the middle of the three binding posts. A shorter outside or indoor antenna will in general give best results if connected to the post marked "short antenna." However, the most efficient connection can best be determined by experiment under actual operating conditions. When testing for best results, it will generally be necessary to slightly readjust the first equalizer when shifting the antenna from one post to the other. When the best connection for a particular set and location has been secured this first equalizer can be finally adjusted, preferably at a low dial setting, after which

no further change should be necessary.

Ordinarily, best reception is had when the receiver is accurately tuned to the incoming signal and the volume control setting reduced to the lowest point for the desired amount of sound from the loud speaker. In no case should the receiver be detuned to reduce the volume, as when this is done the quality of the output from the loud speaker is quite materially affected. As stated previously the volume control and the tuning dial should be operated with the *lowest* setting of the volume control.

Official Parts List

Parts required for building the "Hi-Q-30" are shown below:

- 1 Hammarlund Hi-Q 30 foundation unit
- 1 Hammarlund No. BS-3 three stage band filter unit
- 1 Hammarlund No. RF-3 three stage screen grid amplifier unit
- 1 Hammarlund No. SD Knob Control drum dial
- 1 Hammarlund No. SPC shielded polarized r. f. choke
- 1 Hammarlund No. AF-2 first stage audio transformer
- 1 Hammarlund No. AF-1 push-pull input transformer
- 1 Hammarlund No. AFM push-pull output transformer
- 1 Hammarlund No. PS-45 power supply unit for push-pull '45s
- 3 Hammarlund No. TS Screen grid tube shields
- 1 Aerovox No. CHQ-30 filter condenser block
- 3 Aerovox No. BP-3 triple bypass condensers
- 1 Yaxley No. 810-C center tapped 10 ohm resistor
- 1 Pr. Yaxley No. 422 insulated phono tip jacks
- 1 Yaxley No. 401-S speaker twin tip jack
- 1 Electrad No. RHQ-30 voltage divider
- 1 Electrad No. 3 flexible grid resistor, 1500 ohms
- 3 Electrad No. 3 flexible grid resistors, 400 ohms

Tell 'Em You Saw It in the Citizens Radio Call Book Magazine and Scientific Digest

CORWICO VULCAN LIGHTNING ARRESTER

Also Dissipates Accumulated Static Charges



\$1.00

\$100 Guarantee
With Each
Arrester

Every radio set should be protected from damage by lightning. The best insurance is to equip your set with a Corwico Lightning Arrester. A \$100 guarantee against lightning damage is enclosed with each Corwico Vulcan Arrester.

Static Ejection Improves Reception

The Corwico Vulcan Lightning Arrester is made in accordance with a new principle that dissipates accumulated static charges, thus improving radio reception.

If your dealer cannot supply you with a Corwico Vulcan Lightning Arrester order one direct.



ANTENNA KIT

Consists of Highest Quality Equipment

Now is the time to look over your aerial, lead-in wires, etc. For very little cost you can have a complete new equipment. Buy a Corwico Antenna Kit No. 4. It contains everything necessary for a complete new aerial outfit. The materials are all of the highest quality, representing an unusual bargain for only two dollars and fifty cents.



\$2.50

If your dealer cannot supply you with a Corwico Antenna Kit order one direct.

CORNISH WIRE COMPANY
30 CHURCH ST., NEW YORK CITY

MAKERS OF THE FAMOUS



BRAIDITE HOOK-UP WIRE

- 3 Yaxley No. 3 flexible filter resistors, 5000 ohms
- 1 Electrad Royalty volume control potentiometer 2500 ohms special taper
- 1 Eby No. 6-11 2-prong tube socket marked "Amperite"
- 1 Eby No. 6-11 4-prong tube socket marked 280
- 2 Eby No. 6-11 4-prong tube sockets marked 245
- 2 Eby No. 6-11 5-prong tube sockets marked 227
- 3 Eby No. 6-11 5-prong tube sockets marked 224
- 1 Eby triple binding post strip
- 1 Hart & Hegeman No. 20510 phono toggle switch
- 1 Hart & Hegeman No. 20510 line toggle switch
- 1 Sangamo "Illini" mica fixed condenser .001 mfd
- 1 Beaver-Arrow handle cap, cord connector and silk cord
- 1 Beaver No. L-14 duplex receptacle
- 1 Arrow No. 8339 plug type midget receptacle

With the Accessory and Parts Manufacturers

(Continued from page 119)

thermo-coupled method is used almost universally in factory practice. Both methods employed provide accurate meter readings so that perfect alignment can be made over the various points of the dial range.

For the average simply constructed, single tuning control comprising not more than three gang condensers, an audible method of indicating resonance may be preferred by many service men because of their greater familiarity with this method. This method has been recommended by some radio

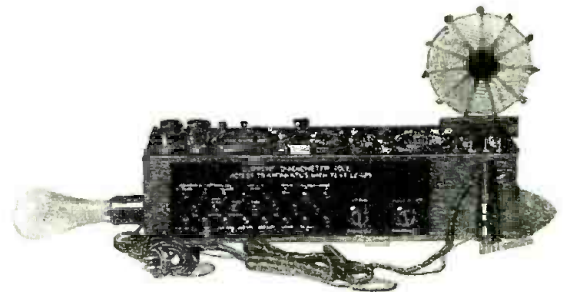

Fig. 3. This illustration gives an idea as to the pin jacks located on the back side of the instrument through which access can be had to all of the apparatus contained therein for external use

manufacturers and is in more or less general use. For the condenser alignment of such sets by this method one of the radio frequency harmonics of the Supreme modulated radiator using a 112 or other good oscillating tube, of a frequency between 1000 and 1500 k. c. or within whatever other frequency range may be recommended by the radio manufacturer, should be tuned in on the radio and all tuning condensers set for maximum signal strength of the same signal. All units should then be in close approximate resonance over the whole tuning range.

However, it is a well known fact that the ear affords less appreciation of quantitative values than does the eye and a visual method of indicating resonance, other things being equal, is to be preferred to any audible method.

The d. c. voltmeter of the model 400-B indicates the strength of any output signal of a radio set when connected to the speaker terminals through a self-contained thermo-coupled and especially designed transformer. The modulated radiator may be used in the manner described above for setting up a

Tell 'Em You Saw It in the Citizens Radio Call Book Magazine and Scientific Digest

signal to which the radio to be synchronized may be tuned. Since the strength of the output signal increases as resonance within the set is approached the meter will show an increased reading as each of the tuned circuits of the receiver is brought to resonance. The maximum reading will have been obtained when all of the circuits are in resonance.

The a. c. voltmeter of all models of the Supreme Diagonometer may be used for indicating gauged tuning condenser alignment by measuring the alternating or pulsating component of the output signal of a receiver. This component, other features being equal, is governed by the synchronous relation of the tuning condensers of the receiver. The reading on the a. c. voltmeter approaches maximum as resonance is approached. The modulated radiator may be used for setting up the signal to be amplified by the receiver for output measurement.

The commercial method of testing tubes in general use is by what is commonly known as the grid bias method. Here indirect indication of mutual conductance is obtained but no indication given of other important contributing factors such as amplification constant reactance of inherent tube capacity and impedance.

For Testing Tubes

In the Supreme method of tube testing oscillation is built up in the tube and the actual characteristics of the tube are determined by the extent to which amplitude of oscillations can be increased. The meter registers the amount of current passing at the time the tube has ceased to build up amplitude of oscillations. A button may then be pressed shorting out the oscillatory circuit and the needle drops back to the point indicating the current passing over the electrons normally emitted by the filament. Charts showing the readings of normal tubes are provided with which comparison may be made and any material deviation from these standards indicates tube deficiency or impairment.

The diognometer described herein will make every known socket analysis test registering all voltages both with load and without load, indicating open circuits or proving continuity of circuits. With this it is possible to obtain a cathode reading either positive or negative in circuits employing the heater type tubes; to obtain screen grid and control grid readings and to make all socket analysis in screen grid circuits without introducing oscillation into these circuits.

A uniform analyzer plug possessing many unusual advantages is another feature of the diognometer. This plug makes possible all analyzes (except UV base) with the use of one adapter. In addition to providing for standard UX or UY tube sockets, it has a vertical testing projection for the attachment of the control grid of screen grid tubes and two horizontal contact plugs for attaching the trolley connections of overhead heater type tubes. All connections are brought to the instrument through the same cable. Another feature of this plug is a snap catch which will prevent its becoming separated from the adapter when plugged into a tube socket with tight fitting contact. At the same time the adapter can be easily and instantly removed when desired by pressing a button to release the snap catch.

Arrester Has Filter Circuit and Static Reducer

ALTHOUGH lightning arresters were known long before radio became the national pastime, they have been used for years with practically no changes or improvements in design. The early types of arresters were made to protect heavy electrical apparatus, power lines and telephone and telegraph equipment.

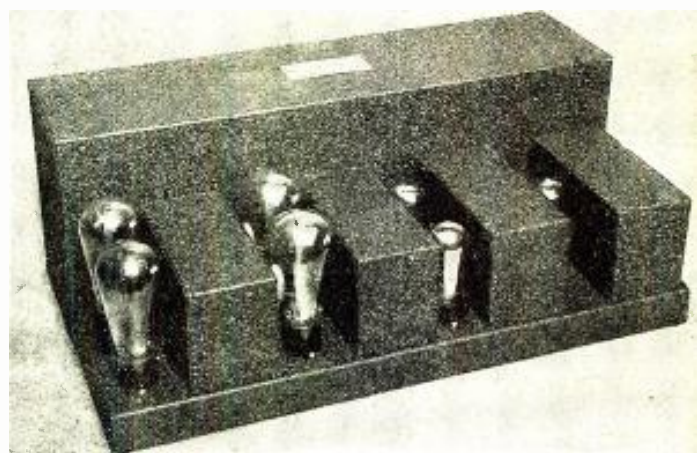

250-3 Stage Push-pull Power Amplifier
 Frequency range 25 to 8000 cycles
 Average gain in amplification . . . 74.5 db.
 Maximum deviation from average . . 4.3 db.
 Undistorted output 15.0 watts
 Signal input for full output . . .05 to .10 volts
 Power supply . . . 110-220 volts 50/60 cycles
 Input and output impedance can be arranged to suit a wide variation in conditions
 List price \$500.00

Win Installation Contracts



POWER AMPLIFIERS

(Licensed under patents of Radio Corp. of America)

WHERE high quality of reproduction is the deciding factor . . . where an important and profitable installation for radio distribution hinges on the performance of the Power Amplifier . . . the high gain and flat amplification curve of FERRANTI Power Amplifiers make their superiority immediately and obviously apparent. For installation in Hotels, Apartments, Clubs, Schools, Restaurants, Churches, Outdoor Parks, Ballrooms, Stores, Laboratories, Y. M. C. A's, Private Homes, and Steamships.

Engineering Information will be furnished upon request

FERRANTI, INC.

130 W. 42nd Street Desk 911 New York, N. Y.

245-3 Stage Push-pull Power Amplifier
 Frequency range 25 to 8000 cycles
 Average gain in amplification 60 db.
 Maximum deviation from average . . . 5 db.
 Undistorted output 4.5 watts
 Signal input for full output . . .05 to .10 volts
 Power supply 110 volts 50/60 cycles
 Input and output impedance can be arranged to suit a wide variation of conditions
 List price \$350.00



Tell 'Em You Saw It in the Citizens Radio Call Book Magazine and Scientific Digest



GET DISTANCE!

The World at Your Fingertips

Baird

SHORTWAVE RECEIVER

WITH a good Shortwave receiver like you assemble from any BAIRD Kit you can enjoy entertainment from all parts of the world. Seventy-eight stations in 21 foreign countries and 49 in U. S. broadcast on Shortwaves. Listen to England, France, Spain, South Africa, South America and even far away Japan and Australia.

BAIRD Shortwave Kits are most scientifically designed; easily and quickly assembled. OCTOCOILS slow the tuning and enable you to receive tremendous distance and listen to it on loud speaker.

BAIRD KIT—No. 1-T
Complete one tube kit; ready for assembling in only 30 minutes. Aluminum base and panel. Wave length Range, 16-100 meters. \$29.50

BAIRD KIT—No. 2-T
A two tube, tuned antenna circuit using Screen Grid tube; assembled easily in one hour; Aluminum base and panel. Wave length range, 16-550 meters, with 10 OCTOCOILS. \$39.50

BAIRD KIT—No. 4-T
Kit composed of detector, tuned antenna Screen Grid R-F and 2 stages audio with power tube in last stage. Only two hours to assemble. Two complete sets OCTOCOILS give range of 16-550 meters. . . . a UNIVERSAL receiver. Complete parts. \$59.50



OCTOCOILS for Shortwave Reception

Most efficient, most rugged and finest Shortwave Coils ever designed. Size 3 5/8" high, 1 7/8" diameter. Plug into ordinary tube socket. Wound with Nos. 12-14-16-25 enameled wire. Set of 4 . . . covering wave length 16 to 225 meters. \$5

If your dealer cannot or will not supply you we will ship, charges prepaid, on receipt of price.

SHORTWAVE & TELEVISION LAB., INC.
70 Brookline Ave., Desk 41 Boston, Mass.

Shortwave & Television Lab., Inc.,
70 Brookline Avenue, Desk 41, Boston, Mass.

Enclosed find \$..... for which ship me, all charges prepaid, the items I have checked below.

No. 1-T, BAIRD Shortwave Kit \$29.50 No. 2-T, BAIRD Shortwave Kit \$39.50

No. 4-T, BAIRD Shortwave Kit \$59.50 OCTOCOILS . . . One Complete Set of four. \$5.00

If you only wish further information on the above, check the item and check here.

Name.....

Street.....

City..... State.....

When radio receivers came into general use, existing lightning arresters were reduced in size and given a new job to perform. While it is true that these arresters did give a measure of protection, they were not designed for radio sets.

Now, after almost ten years of radio, a lightning arrester specifically designed for radio sets, makes its appearance. This arrester is designed by Alex G. Heller, Chief Engineer of the Insuline Corporation of America, and possesses features never before incorporated in lightning arresters.

First of all, it gives protection against lightning and static discharges. Secondly, it acts as a double fuse protection for the radio receiver. Third, it filters static, thus increasing the enjoyment of radio reception, even during periods of electrical disturbances.

The Electrostatic Arrester incorporates and combines several well-known, time-tried principles. It employs the usual high resistance leak from aerial to ground. This leak is of special resistance material, offering very high resistance to weak radio currents, but low resistance to powerful static or lightning discharges. Hence, the high potential currents due to lightning, pass easily to the ground, whereas the radio currents, being of low potential, pass into the set.

A static shield, which is a distinctive feature of this arrester, is placed over the ground terminal and is so shaped that it shields the set connection from the electrostatic field set up across the aerial and ground connections by the high frequency atmospheric electricity. Excessive static is thus bypassed to the ground and this prevents direct sparking between the aerial and set terminals. The shield also serves the purpose of adding a minute electrostatic capacity across the high



Fig. 4. Recently announced by the Insulite Corp. of America, the Electrostatic Arrester is illustrated above

resistance element of the arrester. This is advantageous, resulting in more quiet operation of the receiver.

A choke coil and condenser are also incorporated in the arrester, being connected between the aerial and the set terminals. The constants of the coil and the condenser have such values that they permit the radio currents to pass into the set unobstructed, yet they offer a very high impedance to static discharges of high frequency (low wave length) forcing them to take the path of least resistance to the ground. As a matter of fact, the inductance of the coil, in combination with the capacity of the condenser and the ohmic resistance of the high resistance element combine to form the well-known filter circuit. This circuit is capable of filtering out certain troublesome frequencies of static electricity picked up by the aerial. Furthermore the additional loading effect makes the aerial system more efficient, thus resulting in increased sensitivity and volume.

The insulating property of the condenser protects the set from short-circuits due to accidental contact of the aerial with electric light or power lines. In the event that the condenser should fail, the choke coil in the arrester provides a secondary protection, since it is wound with fine wire, which will burn out before any harm can be done to the set. This arrester, therefore, affords double fuse protection.

F. & H. Radio Laboratories Announce Duo-Lae Speaker

THIS speaker is made by the F. & H. Radio Laboratories in two different models; one using an inductor dynamic speaker, and the other a Tronamic model, which is of the super-magnetic type. The inductor dynamic is for use with machines which employ a one to one output transformer or equivalent, between the radio set and the speaker. The

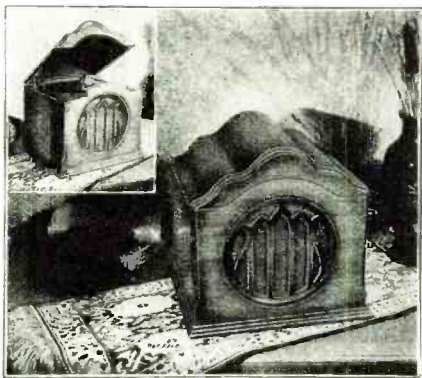

Fig. 5. This illustration shows the Duo-Lae speaker combination made by the F. & H. Radio Laboratories

Tronamic model is designed for all general type machines, including battery sets. The speaker, as well as the phonograph equipment is permanently connected to the radio set, through adapters, and an automatic switch is employed at the volume control which changes from one to the other instantly. The size of the cabinet is: 13 in. wide by 11 in. deep by 12 in. high. Finished in two-tone walnut finish.

Electrad Creates a New Layer-Wound High Resistance

THIS addition to the well known Electrad line of radio resistances and voltage controls is recommended particularly for use as a plate resistor, multipliers for voltmeters and general laboratory work.

The finest grade of Nichrome resistance wire is wound in generously insulated layers around a selected refractory tube.

The entire unit is covered with a heavy coating of moisture-proof enamel of unusual elasticity, baked on at only 400 degrees to prevent loosened connections and fractured wire. Contact bands and soldering lugs are of Monel metal. The lugs are solder-dipped for easy soldering. All parts expand equally under load.

The overall length of the unit is 2 inches, with a maximum outside diameter of 3/8 inches. It is made with resistance ratings from 10,000 to 250,000 ohms.

Durham "Midget" Saves Space

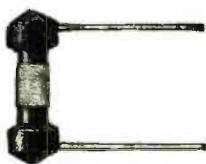

SPACE saving to a great many set manufacturers today is almost as essential as money saving, and in order to meet both of these necessities, the International Resistance Company of Philadelphia have designed what they term their "Midget" resistor.

This resistance unit is known as their Durham Type MF4 1/2 Midget—a very compact and substantially made unit, and well adapted to use in the UX-222 type tube.

These Durham Midget units are supplied by the International Resistance Company in all ranges of from approximately 250 ohms to 5 megohms.

ASTON CABINETS

For Beauty and Quality

Model No. 225

RADIO and PHONOGRAPH

A fine example of perfection in every detail, full information sent on request.

Dealers and Set Builders Write for Our New 1929 Catalog

It will give you full details of this beautiful cabinet, as well as description of many other pleasing ASTON models. Our attractive discounts will interest you.

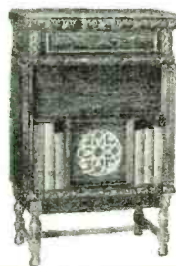

ASTON
Cabinet Manufacturers
1223-1229 W. Lake St.
Chicago, Illinois
Distinctive Originality
in Design of
High Grade Radio Cabinets

Use a REESONATOR

TRADE MARK

for Selectivity—Distance—Clarity

Bring your set up to date! For all sets using an untuned floating or antenna tube, such as Atwater Kent models 30-32-35-37-38, Crosley Bandbox, Radiola models 16-17-18-33-51, Dayfan, Edison, and many other machines. Attaches across aerial and ground leads without tools in less than a minute.

It will enable you to tune sharper and plays with dance volume, stations which are barely audible or sometimes entirely inaudible without it. Requires tuning only when additional selectivity or power is required. Attractively constructed from hard rubber and bakelite in a highly polished rich mahogany color. Guaranteed against defects in material and workmanship for a period of six months. Get a Resonator from your dealer today,

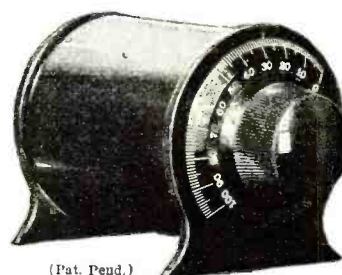

(Pat. Pend.)
\$4.75 COMPLETE Not a wave trap
Over 30,000 satisfied users.

Thousands of These Instruments are being shipped to large concerns in foreign countries (New Zealand, Australia, Hawaiian Islands, etc.) who attach them to the radio sets which they sell. They inform us that without the use of the Resonator it is practically impossible to obtain good reception, due to the fact that broadcasting stations are so distant.

We Guarantee Satisfaction Try one for three days at our risk. If not thoroughly satisfied your money will be cheerfully refunded.

F & H RADIO LABORATORIES

Dept. 110, Fargo, N. D.
Ref.: Fargo National Bank
Dun's or Bradstreet's

Dealers—Over sixty leading wholesalers carry this item in stock.

SEND COUPON NOW
F. & H. RADIO LABORATORIES

Dept. 110 Fargo, North Dakota
I enclose check or money order for \$4.75 for which send me a Resonator postpaid.
Send Resonator C. O. D.
Send Dealers' Proposition.
Please send Literature.
Send Name of Jobber.

Name.....
Address.....State.....

Tell 'Em You Saw It in the Citizens Radio Call Book Magazine and Scientific Digest



Leading the Field in Quality and Dependability

IN the Aerovox Wireless Corporation, you will find a dependable source of supply for quality condensers and resistors. Aerovox paper condensers are accurate, ruggedly made, have a high safety factor and are non-inductively wound, using 100% pure linen paper as insulation material. They are thoroughly impregnated and protected against moisture, have a high insulation resistance and low power factor.

Aerovox mica condensers are the standards of the industry. A complete line of resistors for every requirement includes Pyrohm vitreous enamelled resistors in fixed and tapped combinations, Lavite non-inductive resistors, Metalohm grid leaks, wirewound grid suppressors and center-tapped resistors in all standard and special values.

Send for Complete Catalog

Complete specifications of all Aerovox units, including insulation specifications of condensers, current-carrying capacities of resistors and all physical dimensions, electrical characteristics and list prices of condensers and resistors are contained in a complete 20-page illustrated catalog which will be sent gladly on request.



Choice of 1200 Newest RADIO VALUES



SEND for our 1930 Wholesale Catalog. Filled with exceptional values in parts, kits, short wave kits, screen grid radios, push pull audio radio and consoles.

FREE *Guaranteed Merchandise at Wholesale Prices* CATALOG

WESTERN RADIO MFG. CO.
"The Big Friendly Radio House"
128 West Lake Street Chicago, Ill.

The New SCREEN GRID SETS

FREE RADIO CATALOG

Free Radio Book

148-page catalog of bargains. Everything in radio at wholesale prices. New, humless, Screen Grid, A. C. all-electric and battery operated sets. Accessories, parts and kits. Complete sets as low as \$15.95.

Chicago Salvage Stock Store
509 So. Wabash Ave., Dept. 131
CHICAGO



Pigtail Leads on Durham Resistors for Replacements

THE International Resistance Company announces an interesting development in resistors which are supplied to the manufacturing trade, as well as to jobbers and service stations for use in connection with replacements of resistors in power packs and alternating current sets.

The resistance unit is known as their Durham Type MF4-2;



Fig. 6. This illustrates the Type M. F. 4-2 Durham resistance unit described in the accompanying text

a very ruggedly made unit, the tinned wire pigtail leads being simultaneously moulded with the end of the unit.

Each of the resistors go through an operation, which is unique, consisting of the "flashing" of the resistance unit at twice its normal rating, which in the case of the MF-4 unit rated at 1 watt, means a "flash" load for five minutes at 2 watts.

These metallized resistors are supplied by the International Resistance Company in all ranges of from approximately 250 ohms to 10 megohms.

New Hammarlund Products Include Audio and Assembled R. F. Units

COMPLETE units for the audio and radio channels, separate audio units as well as many special r. f. components for screen grid receivers—the result of more than 5,800 hours of interesting experimenting—have just been brought out by the Hammarlund Manufacturing Company, Inc., 424 West 33rd Street, New York City. The apparatus specially constructed to enable the design of these parts costs \$10,000, while the tools made to permit their manufacture cost \$55,000.

Band Pass Filter

The new parts include a three stage radio frequency band filter designed to work into a screen grid radio frequency amplifier; a three stage screen grid radio frequency amplifier unit; a shielded polarized radio frequency choke; a group of audio amplifying apparatus which includes straight and push-pull transformers, and a power supply for the receiver as well as for a pair of 245 tubes, this containing a specially designed power transformer, voltage divider, condenser block and choke unit.

The three stage band filter unit, BS-3, is a completely wired and assembled three stage band filter pre-selector tuning unit, containing a matched .0005 mfd three gang Battleship midline condenser housed in an aluminum shield, and a set of three special radio frequency filter coils, each enclosed in a copper can. This unit affords absolute flat top tuning, producing a pure radio frequency signal for entrance into the r. f. and a. f. amplifying channels.

The companion unit of the BS-3 is the three stage screen grid r. f. amplifier, RF-3, also completely wired and assembled. This also contains a matched .0005 mfd three-gang Battleship midline condenser, enclosed in an aluminum can with partitions shielding each condenser, and three matched r. f. coils in separate copper cans, each can also containing a shielded r. f. choke. The r. f. unit which feeds into the detector also con-

tains a metallized grid leak and mica condenser. Both the BS-3 and RF-3 units are tested and sealed before leaving the factory.

Shielded R. F. Choke

The shielded choke, SPC, is housed in an aluminum shell and is polarized. The polarization, together with the choke's high inductance and low distributed capacity permits a total absence of an external field, preventing feedback and consequent receiver instability.

To further prevent feedback and permit greater amplification, there is the aluminum screen grid tube shield, TS. The control grid outlet which protrudes through the top of the shield is protected with soft rubber grommet. This prevents vibration as well as accidental shorts. It is designed for use with sub-panel sockets of the Eby type.

The first stage audio frequency transformer, AF-2, has a ratio of 1½ to 1, while the ratio of the push-pull input transformer, AF-4, is 2 to 1, on each side.

The primaries of both transformers are very large. This coupled with the use of treated laminations grouped in a special way into unusually large cores permits uniform amplification from as low as 16 cycles to as high as 4,800 cycles.

One of the output transformers, AF-M, is an impedance matching unit designed to match 245 tubes to magnetic speakers, while the other AF-D works directly into the moving coil of a dynamic speaker. This unit takes the place of the impedance matching transformer usually supplied with the speaker. The large cores of treated laminations which are also used here, prevent current saturation, thus affording true energy transfer.

All these transformers are enclosed in enameled steel cases with pigtail terminal leads for sub-base connection.

Another 13,000-foot factory unit has been added to the facilities of Hammarlund Mfg. Co., 424-428 W. 33rd Street, New York.

This latest addition has been made necessary by an increase in the Hammarlund business and with the additional floor space greater production may be secured.

Seven Tonatrol Models Made For Circuit Connections

SEVERAL interesting methods for connecting variable resistors are shown schematically in the little descriptive folder covering the Super Tonatrol recently announced by Electrad, Inc., 173 Varick St., New York City.

There are seven types of these Tonatrols which will adequately meet most of the usual volume control requirements of modern circuits. Super Tonatrol type No. 1 is a 25,000-ohm potentiometer type for control of the antenna input volume. Antenna connects to No. 1, ground and ground connection of coupler to No. 3, antenna connection of coupler to No. 2. The fixed resistance is always between antenna and ground, the arm going to the top of the antenna inductance for increase or decrease of volume.

A second use of a Super Tonatrol type No. 2 is a 10,000-ohm potentiometer with a resistance curve especially adaptable for screen grid bias control for screen grid tubes in radio frequency amplifiers. The exact value of the fixed series resistance may be ascertained by consulting the table supplied with that unit. This same type No. 2 may also be used for control of plate voltage of 227 tubes in radio frequency amplifiers.

The third use of the Super Tonatrol No. 3 is as a 50,000-ohm rheostat for voltage control of the grid bias in radio frequency amplifiers. It enables a more even and accurate control. A table of fixed resistance values in various circuits is supplied in the carton.

Type No. 3 is a 10,000-ohm rheostat especially adaptable for plate voltage shunt control. The table of values is also included in the literature.

The NEW H-F-L Mastertone Laboratory Made Receiver

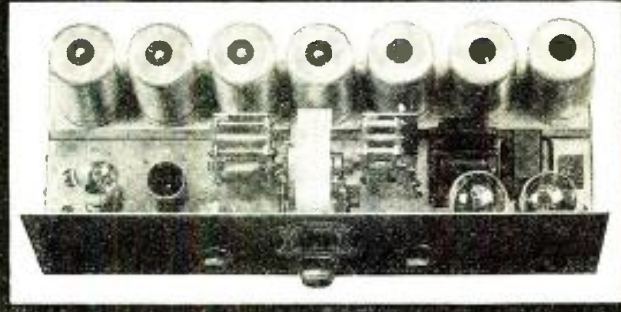

Completely Built and Assembled by H-F-L Engineers—Shipped ready to Operate

After two years of tireless research and tests under all conditions, H. F. L. engineers have perfected the **Mastertone**—a radio that sets an entirely new standard of performance.

Such startling realism! Such unflinching accuracy. Its great power and sweet tone will thrill you. Its keen sensitivity and positive 10 Kilocycle selectivity will amaze you. With only a wire screen or metal base aerial built in the cabinet, the **Mastertone** gets distant stations sharply, clearly and distinctly over entire musical scale, with magnetic, dynamic or horn speakers, and without a bit of hum.

THE MASTERTONE in Detail

All metal completely shielded chassis: 7x21 x 7½ inch. Fits nearly all consoles. 11 tubes operating at peak efficiency (5-224; 3-227; 2-245; 1-280). Single dial positive one-spot tuning; Humless AC Operation; Uses 5 Screen-Grid tubes, 5 Tuned R. F. Circuits; High Power Screen-Grid Detector, with 175 volts impressed on plate; Automatic line voltage control inbuilt holds voltage against fluctuating; 100-volt DC dynamic field supply incorporated; 3-stage phonographic amplifier; Finest quality precision made parts.

Built by Hand—Yet Low Priced

Quality—not quantity—the H. F. L. Mastertone standard. One demonstration will convince you that it's the master receiver of all times. Fully guaranteed.

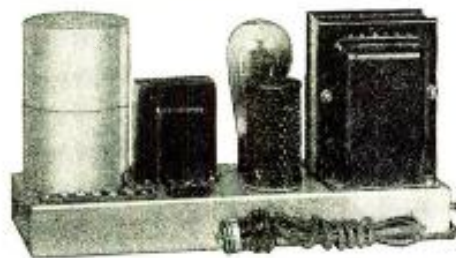

H. F. L.

Power Master

Not an ordinary power pack, but a specially developed unit of the Mastertone, built separately to simplify installation. Has oversized transformer, full wave type 280 rectifier tube.

**Write Today for Complete Description and Price—
Send Coupon Below**

HIGH FREQUENCY LABORATORIES
28 North Sheldon St., Dept. 11 Chicago, Ill.

High Frequency Laboratories,
28 North Sheldon St.,
Dept. 11, Chicago, Ill.

Gentlemen:

I am interested in the new H. F. L. Mastertone laboratory made receiver. Send me complete details and price.

Name.....

Address.....

Tell 'Em You Saw It in the Citizens Radio Call Book Magazine and Scientific Digest

Make \$75 to \$100 a week!
Starts You Charging Batteries



Let me show you how to make big money right from the start. I've prepared a **FREE** book explaining all details. First week's profit pays for all equipment. You can get all the battery charging business in your community with my Service Station Charger—it's years ahead of ordinary chargers—handles 50% to 70% more batteries. I explain everything—start you in a business of your own and put you on the way to big money. Write for **FREE BOOK**.

C. F. HOLMES, Chief Engineer, Dept. G
 Independent Electric Works
 4912 N. Clark St.
 Chicago, Ill.

FREE BOOK—Just Out

Big Profits

FREE 148 Page Book
of BARGAINS ~ Everything in RADIO

Largest Radio Store in the World

Write for new 148-page book of radio bargains from this immense store—full of all the latest in radio. New, humless, Screen Grid, A. C. all-electric and battery operated sets. Beautiful consoles, accessories, parts and kits at astounding prices.

CHICAGO SALVAGE STOCK STORE
 509 So. Wabash Ave. Dept. 131 Chicago



A LEADING Hotel of this Popular Resort. Rooms—Single—Double or ensuite with private baths. Unexcelled cuisine and service. . . . American Plan. . . .

Ownership Management
MARY L. BIÖREN
 Also under same management
 The Boscobel and Ocean Avenue Hotel, Ocean Grove, N. J.

MARLBOROUGH HOTEL
 ASBURY PARK, N. J.
 "ON THE ATLANTIC"

Public Visits New Submarine



Hundreds of persons visited the navy yard at Washington, D. C., recently to inspect one of Uncle Sam's largest types of submarines, which is tied up at the dock for public inspection. This undersea craft, the S-48, carries a crew of 40 men and four officers. Lieutenant Commander William Lorenz is in command

Reports Success of Malaria Treatment

The new malaria treatment of general paralysis has been successful in arresting the disease in 38 out of 100 patients so treated, Dr. Paul O'Leary of Rochester, Minn., has reported to the American Medical Association. Observation of the group of 100 patients extended over five years. The 38 patients in whom the disease is arrested have been restored to economic efficiency to the extent of supporting themselves and their families.

The outcome of general paralysis or paresis, the end-results of syphilis, has heretofore invariably been fatal, death coming after a long period of both mental and physical disability and suffering. The important feature of the results reported by Dr. O'Leary is that regardless of the prolongation of life, the 38 patients in whom the disease is arrested are able to resume their normal activities, instead of languishing in some hospital or institution, a continual and increasing burden to themselves and their families.

Besides the 38 arrested cases, 31 patients now show improvement. Seventeen have not benefited and 14 are dead. Of these 14, only 5 died of malaria, the other deaths being due to the paresis, to accident, suicide and various diseases.

The principle of the malaria treatment is that the fever produced in the patient's body by the disease is able to kill the resistant organisms causing the general paralysis. In some patients who did not react to the malaria treatment, Dr. O'Leary and his associates used injections of typhoid vaccine. This treatment is less severe but the results are less striking. Cases of arrest of the paralysis are fewer and slower in development.

Tell 'Em You Saw It in the Citizens Radio Call Book Magazine and Scientific Digest

Earth as Power House Yields 200,000,000 Amperes

THE earth itself is a huge electric dynamo generating enough current to supply light, heat and other electrical needs to the ten largest cities in the United States for at least one million years. Recent researches on thermal reactions inside the earth, conducted by Dr. Ross Gunn, civilian scientist of the Naval Research Laboratories, and inventor of a short wave oscillator and airplane altimeter that have been taken by the radio and aircraft industries, indicate that the earth is the greatest known electrical wonder in the universe.

Dr. Gunn has published a theoretical treatise on his studies in the Physical Review. The intricate theoretical problem of the earth's electrical condition showed that the currents generated inside the earth amount to more than 200,000,000 amperes. Dr. Gunn is careful to emphasize that this tremendous source of energy is unavailable for use by man. Like atomic energy, it will be kept in Nature's storehouse for the use of the generations of perhaps a million years in the future, he says.

According to Dr. Gunn, the tremendous electrical currents

Planes Take Part in Navy Games

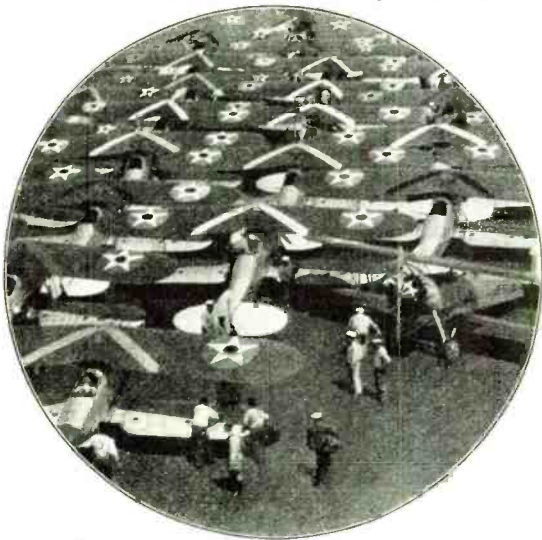

A view from the bridge of the U. S. S. Saratoga during the recent war games off Panama, showing the numerous planes of the ship's air unit on the deck waiting to take off and participate in the maneuvers

that are produced inside the earth arise from the motions of the tiny electrical charges known as electrons. The motions are caused by the very high temperatures existing well inside the earth's crust.

Due to a peculiar and complicated type of interaction the electrons are caused to drift around the earth's axis of rotation. This drift of electrons constitutes an electric current which is so large that, if it were sent through the huge cable supporting Brooklyn Bridge, it would melt them in less than a thousandth of a second.

The presence of the currents that flow in the hot interior of the earth may be detected by anyone who cares to observe the action of a magnetic compass on the surface of the earth, says Dr. Gunn, for it is precisely these deep-seated electric currents that orient the compass needle in a north-south direction. He adds that it has been known for thousands of years that the earth behaved like a giant magnet, but the mechanism by which this magnetism was produced was not understood.

The study pursued by Dr. Gunn sheds much light on the manner in which the earth was originally formed.



THE largest, heaviest dynamic now available—especially adapted for use in theatres, public address systems, auditoriums and wherever tremendous volume, with undistorted output is required. Dwarfs all others in performance, size and appearance.

A Few Facts about the Best Theatre Dynamic

- Over 4 miles of copper wire on the coil.
- Special Magnetic Steel Housing.
- Flux density in magnetic lines, 114,000 (far greater than any other dynamic speaker).
- Diaphragm 13-5/16"
- Length 17-15/32"
- Width front to back 9-13/16"
- Height 14-13/32"
- Weight 53 lbs.
- For operation on 105 to 120 volts AC, 50 to 60 cycles.
- Write for information on the 6 volt DC model.

The Best Theatre Dynamic will entirely alter your present conception of speaker performance.

Send the coupon for full information about this remarkable speaker. Now ready in two sizes. Chassis only, Theatre model—\$125.00 less tubes. Home model \$95.00 less tubes. (Also models for D. C. operation).

BEST Theatre DYNAMIC for HOME and THEATRE



Best Manufacturing Company
1200 Grove Street, Irvington, N. J.

Please send me full details of the great Best Dynamic Speaker.

Name _____

Address _____

I am a dealer service man theatre owner
(PLEASE CHECK)

Tell 'Em You Saw It in the Citizens Radio Call Book Magazine and Scientific Digest

Two essentials for perfect radio results



I. C. A. Electrostatic the new principle static-reducing arrester

The I. C. A. Electrostatic gives you four important advantages: 1—Lightning Arrester. 2.—Static Noise Reducer. 3.—Fuse Protection. 4.—\$100.00 Free Insurance Bond. The lightning arrester feature employs the silicate of carbon principle that offers very high resistance to powerful lightning discharges. The shield over the ground terminal shields the set connection from the electrostatic field between the aerial and ground con-

nections. This acts as a static noise reducer. Also, a choke coil and condenser are connected between the aerial and set terminals. This aids in filtering static noises inducted into the set through the aerial. As a further protection, the choke coil is wound with wire that acts as a fuse and breaks the circuit, thus saving the set. Every set, new or old, should have an I. C. A. Electrostatic for the greatest protection and the best results.

Resistovolt or Antennavolt

And every A. C. set needs a Resistovolt or an Antennavolt to save costly tubes from blow-out caused by line surges and over-loading, also to save the set in case of short circuit. Both Resistovolt and Antennavolt are made in two models: Light Duty for sets consuming 125 watts, and Heavy Duty for 250 watts. Resistovolt is \$1.75 and Antennavolt is \$2.25. Antennavolt is the same as Resistovolt in



Price \$1.75

every respect except that Antennavolt has a connection enabling the use of the house-wiring as an antenna, thus reducing static and enhancing reception.

No A. C. set owner can afford to be without either Resistovolt or Antennavolt. It means absolute protection against blown-out tubes and damages caused by short circuit in the set.

INSULINE CORP. OF AMERICA

78-80 Cortlandt Street, New York, N. Y.

Send for 1929-30 catalogue showing latest radio and television apparatus.



FREE RADIO CATALOG

THE NEW SCREEN GRID RECEIVERS

WRITE TODAY

Send for large, new illustrated Catalog "C-1" showing the latest of everything in radio—featuring the new Screen Grid, A. C. all-electric sets at wholesale prices.

ALLIED RADIO CORPORATION

711 W. LAKE ST. CHICAGO



GUARANTEED RADIO SERVICE

Repairing—Testing—Designing and Electrifying

WE are completely equipped to repair and test any make Receiver or Power Device. Our high class workmanship, together with modern testing equipment, enables us to rapidly locate the defects involved in your receiver in a scientific manner. All work is guaranteed and our charges are no more than paid for inferior workmanship.

DEALERS, JOBBERS AND MANUFACTURERS—Let us give you an estimate for repairing and servicing all your defective radio apparatus. Our prices are low and the workmanship is of the highest class obtainable.

RADIO SERVICE LABORATORIES, Inc.
440 So. Dearborn St. Phone Harrison 2870 Chicago, Ill.

Living Cells Observed Under Ultra-Violet Light

ULTRA-VIOLET radiation, the "invisible light" that plays so conspicuous a part in present-day health culture, has been drafted into the service of the laboratory scientist, searching for the inner secrets of the workings of living cells. Although they are themselves invisible to the human eye, they can cause other objects to shine in the dark with a light known as fluorescence.

A microscopic technique taking advantage of this property was described at the meeting of the Thirteenth International Physiological Congress at Boston by Dr. P. Ellinger and Dr. A. Hirt, of the Heidelberg University. They injected into the organisms to be studied a dye known as fluorescein so called because of the brilliancy of its fluorescent light when irradiated with ultra-violet rays. Cells impregnated with this dye show up every minute detail of their structure as though etched in fire, and the activities of every particle of protoplasm in them can be watched with the highest powers of the microscope.

Congressmen Get Synthetic Tan

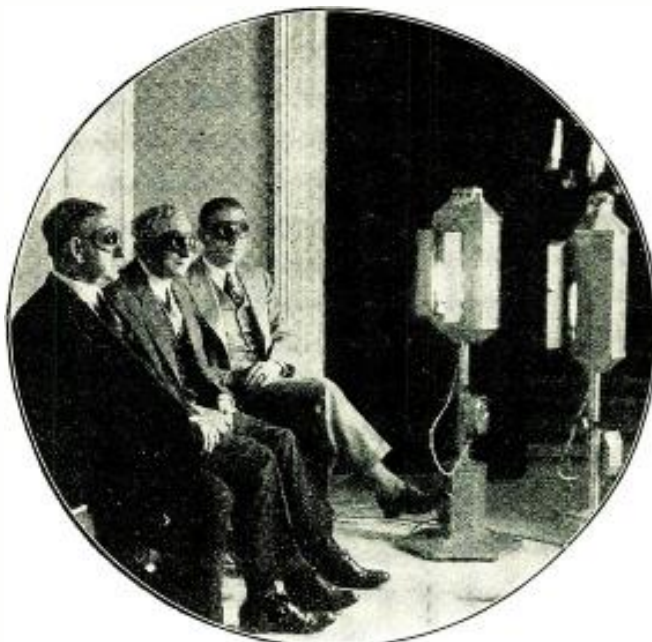

Photo shows congressmen acquiring a coat of synthetic tan under the powerful rays from the recently developed sun light arcs, which have been installed in the shower rooms of the House Office Building. Left to right: Representative L. C. Dyer of Missouri, Representative Frederick N. Zihlman of Maryland and Representative C. L. McLeod of Michigan

Government Radio Station to Check Frequencies

RADIO stations of ships, broadcasters or amateurs will have little excuse for departing from their assigned frequency or wave length after December. Then the constant frequency station of the Department of Commerce will be in operation at Grand Rapids, Nebraska, engineers will listen in to all kinds of stations, and check their frequency. Whenever one is found to be deviating from the place assigned, the operators will be immediately notified. Or if the station operators believe their station to be deviating, a telephoned request to the constant frequency station will result in an immediate test and report.

The instruments of the station will be installed in a two-story brick structure on a 50 acre tract and will be operated by a staff of about 20 men. The antennae will be 70 feet high and will stretch in all directions. Some will be as long as two miles. One, especially for receiving signals from Europe.

Tell 'Em You Saw It in the Citizens Radio Call Book Magazine and Scientific Digest

"Singing Crystal" May Make Possible More Accurate Clocks

A CRYSTAL of quartz, similar to those used in radio stations to keep the wavelength constant, may make possible a new era of accurate clock making. Experiments at the Bell Telephone Laboratories by Dr. W. A. Marrison, have shown that such a crystal may be made to perform the work of a clock pendulum. Already he has constructed a timepiece that compares in accuracy with the very best of observatory clocks until a few years ago. Since a pendulum is not required, the crystal clock does not require the firm pier on which observatory clocks must be mounted. The crystal clock could be used in a tall office building, on shipboard, or even in aircraft if needed.

When a quartz crystal, properly cut, is placed between two metal plates, and a vibrating electric current applied to them, the crystal can be made to oscillate at a certain rate. By varying the size of the crystal, the rate at which it vibrates can be regulated, and the crystal maintains the same rate with great accuracy. This is used in crystal controlled radio stations.

But a much higher accuracy is needed for a laboratory standard, and this has been attained by Dr. Marrison. His

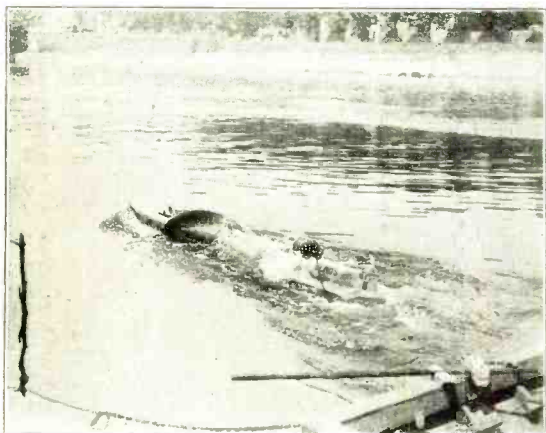

Wide World Photo

The "Venus," a small model of a new idea in future ocean liners, which its inventor, Jean Vignaud, is testing off the Ile de La Jette, France. An ocean liner copied from the model could cross the Atlantic in 30 hours, according to the inventor.

apparatus has been developed primarily as a standard of frequency. The application as a clock is a by-product, but one which may eventually prove of greater importance.

Three crystals are used by Dr. Marrison, each vibrating 100,000 times a second. Each crystal is enclosed in a thickly padded chamber, to prevent temperature changes, and the whole is covered with a glass bell jar, so that the air pressure and humidity may also be kept constant. Three separate oscillating electric circuits from vacuum tubes keep the crystals running, so from each unit there comes an alternating electric current, changing exactly 100,000 times a second. Any one of these three crystals can be connected with the clock, through the medium of another electrical circuit called a "submultiple generator," also using vacuum tubes. One of these takes in the 100,000 cycle current and gives out current alternating 1,000 times a second. This current operates a motor, geared to the clock face in such a way that it keeps accurate time when the crystal vibrates accurately. A contact on this clock gives an electrical impulse every second.

Though the clock has not been running long enough to check its accuracy over long periods, shorter observations show it to keep a constant rate within about a hundredth of a second a day.

SHORT WAVE With Your Present Receiver

Experience reception on short waves, by attaching a "Submariner" to your present receiver, whether AC or DC. There is a model for every need and requires no changes of any kind to your receiver. Only a few seconds is required to attach or detach.



Users of "Submariners" in U. S., England, Holland, Germany, Australia and many other distant countries broadcasting. In addition to hearing broadcasting from these far countries, thousands of code messages have been received from every part of the world.

THE SUBMARINER

has been sold in all parts of the world since 1926 and is not only the pioneer, but its many improvements enable every set owner to secure as efficient results as the best short wave receiver could give, with only a fraction of its cost. The "J" feature, an exclusive "Submariner" achievement, gives five times greater volume than any other adapter. Prices, AC or DC, are: Fixed wave band, 16-32 meters, \$17.50. Fixed wave band, 16-32 meters, "J" feature, \$22.50. Interchangeable coil model, 12-160 meters, \$22.50. "J" feature and interchangeable coil, 12-160 meters, \$27.50.

Will be sent prepaid on receipt of price, or C.O.D. if \$1.00 accompanies order. Dealers and Jobbers write for sales proposition.

J-M-P MFG. CO., INC.

3432 Fond du Lac Avenue

Milwaukee, Wis.

At Last - Restful Reception! X-L SENTINEL Radio Time Switch



Set the SENTINEL Radio Time Switch, Climb Into Bed and Enjoy Radio as You Never Have Before!

Now you can relax and really enjoy your radio. No need to sit up. Should the music lull you to sleep it's all right—X-L SENTINEL Time Switch turns off reception at the time set. Type ADS . . . works on A.C. or D.C. Electric sets or sets with eliminators. Type AB . . . for sets using "A" and "B" Batteries. X-L SENTINEL saves current and wear on tubes. Can be used also on window displays and neon signs.

ONLY \$6.75 LIST

X-L LINK

Link Provides 100% Voltage Control Plus 5 Exclusive Features

1. Double Socket outlet for A.C. Set and Dynamic Speaker—or for "A" and "B" Eliminators.
2. It is Antenna and perfect Ground.
3. Line Switch.
4. Fuse protection for entire set.
5. Perfect link between set and light socket.

See Dealer—or Send Direct

Enjoy the thrill of these wonderful new radio conveniences. No installation on either. Just plug into light socket. Postage paid if cash with order. C.O.D. plus postage. Order TODAY. Be sure to specify type of Sentinel wanted.

X-L RADIO LABORATORIES
1224 Belmont Ave., Dept. 502-P, Chicago

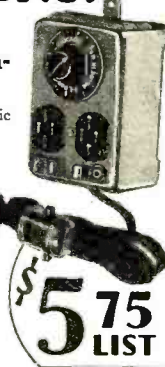

\$5.75 LIST

Tell 'Em You Saw It in the Citizens Radio Call Book Magazine and Scientific Digest

**FREE
RADIO BOOK**



**WHOLESALE
PRICES**

**Everything in
Radio at Wholesale**

We supply every radio need from our mammoth stock of parts and sets of the most modern design. Lowest wholesale prices. Immediate service. Write for big, illustrated Catalog "C-1" full of bargains. Sets as low as \$15.95.

**ALLIED RADIO
CORPORATION**
711 W. LAKE ST. CHICAGO

Service Testing Instruments

FOR the past several months the engineers of the General Radio Company have been developing three new instruments for the radio serviceman's laboratory. As soon as the final inspection tests have been completed, descriptive literature will be sent to all those who have requested it.

The new apparatus will supplement the line of GENERAL RADIO SERVICE-TEST INSTRUMENTS, which includes a direct-reading ohmmeter, a capacity meter, and a mutual-conductance meter. The latter tests screen-grid tubes as easily as it tests triodes, with no changes in the internal connections and with no special attachments.

GENERAL RADIO Co

30 State Street
Cambridge, Mass.

274 Brannan Street
San Francisco, Cal.

LIFELONG UNDERGROUND AERIAL

Reduces static and other noises, gives you better reception. No more lightning danger, no more poles and wires on the house. ITS GUARANTEED FOR LIFE AND ONLY \$4.00 PREPAID.



Dealers Write for Big Discounts

Expert Radio Shop

14236 Indiana Ave.
Detroit, Michigan

RADIO BARGAINS

Brand New 7 tube A. C. sets \$36.75 guaranteed. Used radios as low as \$9.90. Power transformers and chokes: No. 1003 Sec. 400 V. 7 1/2 V. C. T. to first chokes. 7 1/2 V. C. T. 2.5 V. C. T. to case 1 1/2 V. 3 chokes. For one 281. one 250. one 227. four 226.....\$5.00
No. 1002 Sec. 450 V. 7 1/2 V. C. T. to first choke. 7 1/2 V. C. T. 2 1/2 V. C. T. to case 1 1/2 V. 3 chokes. For one 281. one 250. four 226.....\$4.75
No. 875 Secondary 375 volts—375 volts. 5. 5. 2 1/2. 1 1/2 and 1 1/2 high and low primary and 2 chokes. For 280. two 171A. five 226 and one 226.....\$4.25
Complete list upon request.

CHAS. HOODWIN CO., 4240 LINCOLN AVE., DEPT. M4, CHICAGO, ILL.
Dealers in Bankrupt Radio Stocks

Would Break Belgian Radium Monopoly

THE Belgian monopoly of radium, indispensable in the modern treatment of cancer, has led to such a revolt in medical circles, that it is confidently expected that American money will soon be put into radium mines in Colorado and Utah, and possibly also in West Africa.

Just how cheaply radium can be produced from American ores in Colorado and Utah, it will not be known until the Bureau of Mines does considerably more experimental work.

Provision for such experimentation will be made in a bill to be introduced in the House this fall.

At present, it is believed that it probably would cost at least \$22,000 per gram to recover radium from American ores.

It is charged that Belgian interests produce it for \$10,000 per gram, while selling it for \$70,000 per gram.

In West Africa, it is claimed that radium can be extracted from pitchblende for \$8,000 per gram.

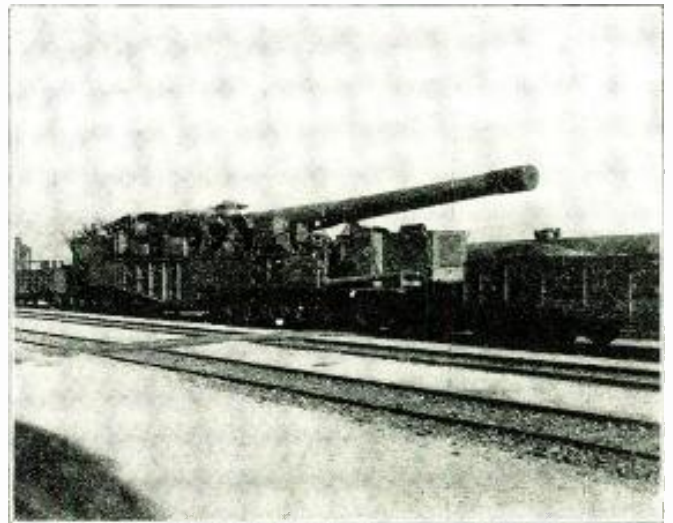

Wide World Photo

The largest and heaviest gun ever transported across the United States. It is for the Benicia Arsenal near San Francisco. More defense for the Golden Gate. Built at Watervliet, N. Y.; weight is 736,000 pounds; length, 95 feet overall; shoots a 14-inch shell weighing 1,660 pounds; powder charge, 463 pounds; maximum range, 42,000 yards, or about 24 miles. Photo shows the gun on a flat car en route to Benicia Arsenal. It is so constructed that it can be used on a permanent emplacement or with the troops in the field.

Why Actors Enjoy Tragic Roles

THE actress who weeps through a tragic love scene and has her audience weeping with her is probably thoroughly enjoying the evening's work. The actor who is so despicable a character that the audience yearns to come up on the stage and take a hand in his downfall probably has no feeling of repugnance toward his part in the drama.

This personal relation of the actor toward his roles has now been studied by a psychologist, Prof. John T. Metcalf, of the University of Vermont. Speaking before the International Congress of Psychology, Prof. Metcalf said that the actor enjoys his work when he is satisfied with his art, and his work is unpleasant when he feels his own shortcomings.

To what extent an actor feels the emotions he portrays has long been a matter of interest and dispute. Prof. Metcalf has concluded that the actor does imaginatively identify himself with some person and situation outside of himself. And the more fully he is capable of this, the more successful he will be in conveying the desired effect to the audience. But if he begins to experience the real sensations of anger or sorrow, he slips up in his art, for then he is behaving in a real and practical way instead of using his art to represent an imagined situation in the realm of unreality.

Tell 'Em You Saw It in the Citizens Radio Call Book Magazine and Scientific Digest

Radio Aids Check on Bird Migration

THE age-old problem of where birds go in winter may be solved by the assistance of radio.

Prof. Johannes Thienemann at a bird station at Rossitten, East Prussia, was able, by means of requests for information via microphone, to get valuable check-ups on the movements of a group of storks released after number bands had been attached to their legs at the beginning of the fall migratory season last year.

Band numbers sent in by interested members of his radio audience showed that five days after the storks' release on September 26, they were in the Carpathian mountains of Czecho-Slovakia. By October 10 they were near Messini in the southwest of Greece, having flown approximately 1250 miles in two weeks, almost due south. This checks previous experiments with stork migration made in Germany, but the use of the radio naturally speeds up considerably the process of gathering the required information. Whether the experiment will be repeated again this fall is not yet known.

New Fireproofing Formula

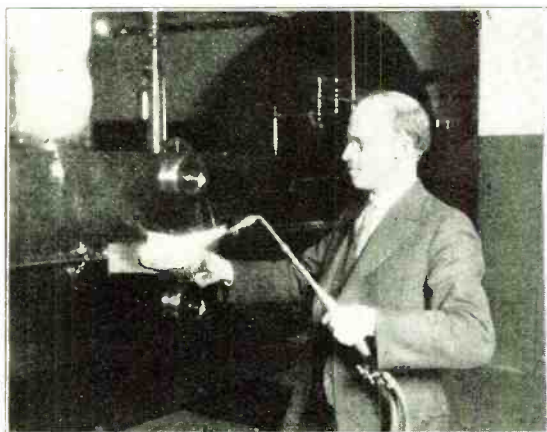

Wide World Photo

Said to be the first fire and insect proofing process, which once applied acts permanently, a new formula completed by a doctor and a dentist in Los Angeles is being observed with interest by scientists and fire department officials. Known as conite, the fireproofing formula is the result of several years of experimentation by Dr. O. T. Hodnefeld, a Los Angeles optometrist, and Dr. W. W. Shartel, a dentist. Tests made with wood and paper treated with the new chemical compound show that the materials treated with conite do not burn in temperatures reaching 6,000 degrees. Dr. O. T. Hodnefeld holding pieces of canvas and paper impregnated with conite under an oxy-acetylene flame of between 5,000 and 6,000 degrees Fahrenheit.

Holes in Submarines Patched Under Water

A NEW method for quickly patching holes in disabled submarines under water has been tested by U. S. Navy officials and pronounced successful. The device looks something like a pneumatic hammer, but employs charges of high explosive to drive steel studs through the shell of the sunken vessel, fastening an emergency patch over the rent. It is the invention of Robert Temple, of Denver.

The advantages claimed for the new submarine patcher are great speed in emergency operations, and ease of handling under water. The method now in use requires a comparatively slow-working air drill, dragging many feet of cumbersome hose behind it. The new tool drives a steel stud, three and one-half inches by one-half inch, through a half-inch steel plate at a single blow. It makes no noise, and complete safety for the operator is claimed.

FOR UNITS THAT ARE PARTICULARLY ADAPTED TO A. C. AND SCREEN GRID CIRCUITS SPECIFY FROST RADIO

FROST RADIO

YOU SHOULD SEND FOR THE LATEST EDITION OF OUR CATALOG BEFORE SELECTING ANY UNITS FOR YOUR RECEIVER

Mail the Coupon Now
HERBERT H. FROST, Inc.
 Main Office and Factory
 Elkhart, Indiana

HERBERT H. FROST, Inc. C. B. 11-29
 160 North La Salle St., Chicago, Ill.

Send me the latest edition of your catalog of Frost Radio Units and Combinations suitable for A. C. and Screen Grid use.

Name.....
 Address..... City..... State.....

For
PERFECT PLAY
use

ARCTURUS
BLUE A-C LONG LIFE TUBES
Clear Humless Reception

ARCTURUS RADIO TUBE COMPANY, NEWARK, N. J.

Tell 'Em You Saw It in the Citizens Radio Call Book Magazine and Scientific Digest

\$175.00

**K O L S T E R
DYNAMIC REPRODUCER**

Combined with

**210 Power Amplifier
and "B" Supply Unit**

\$ 49⁵⁰
(without tubes)

Special

(without tubes)

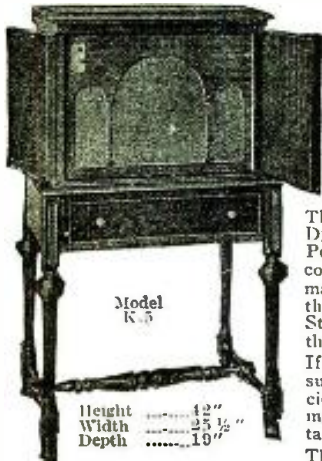

This famous genuine Kolster K-5, AC Electro-Dynamic Reproducer is complete with a 210 Power Amplifier and "B" Supply Unit all self-contained on a steel frame. This real fine matched rugged Unit weighs 45 lbs. without the Cabinet. The Cabinet itself is Pencil-Striped Walnut, beautifully designed with Cathedral grille.

If desired, the 210 Power Amplifier will also supply 22, 67 and 90 volts "B" current, sufficient for any set using up to 8 tubes. An automatic voltage regulator tube, UX-874, maintains the "B" voltage silent and steady.

This Electro-Dynamic Reproducer can be used with any battery or AC set, replacing the last audio stage, or be used with all tubes of the set. Wherever used it will bring out every shading and range of tone; every note is reproduced with utmost faithfulness, pure and undistorted. It will modernize any radio receiver.

Uses 1—UX-210, 2—UX-281 and 1—UX-874 tubes.

A 20-ft. cable is included with each instrument. Operates direct from 50-60 cycle, 110-120 volt AC current.

Brand new in original factory cases and guaranteed. Every Reproducer is serial-numbered and has factory guarantee tag enclosed.

AMERICAN SALES COMPANY

19-21 Warren Street

New York City

JEEMS

EASY TROUBLE SHOOTER

The Quick Method for Locating Trouble in Your Receiver

REVISED to include all of the forty licensed factory sets as well as super-heterodynes, this handy chart is highly recommended by service and repair men as a valuable asset in the work shop.

Accurate, Sure, Complete, Practical

By Mail, 50c

Roberts Radio Service

Caxton Building

Chicago, Illinois

**Danger of Lightning in Airplanes
Relatively Small**

ALTHOUGH the danger of being struck by lightning is greater to the person flying in an airplane than to the person standing away from trees on the ground, it is not a very serious risk in the view of weather experts.

Only about one bolt of lightning out of every hundred reaches the ground, so for this reason the danger from lightning is greater in the upper air. Most lightning flashes travel from one part to another of the same cloud in a path approximately parallel to the earth's surface. The airplane may fly into the path of such a lightning flash, in which case it would be struck though not necessarily severely damaged.

The frame of an all-metal plane does not offer any added hazard, in the opinion of weather experts. If anything, the metal plane should be the safer, for the frame of such a plane would absorb or carry off the discharge of electricity in a manner similar to the action of a lightning rod. It is believed that planes could be equipped with brush dischargers, or other appliances that would make them lightning-proof.

The danger from thunder storms would still remain, however, for the turbulent winds which always accompany thunder and lightning present a serious hazard to the aviator. There is only a relatively small chance that a plane would be struck by lightning even when flying through an electrical storm, for at a distance of 100 feet from the path of the lightning the plane would be safe. But the flyer is bound to strike the winds. And severe winds, especially the winds blowing up and down which one meets in a thunder storm, may easily completely demolish a light airplane.

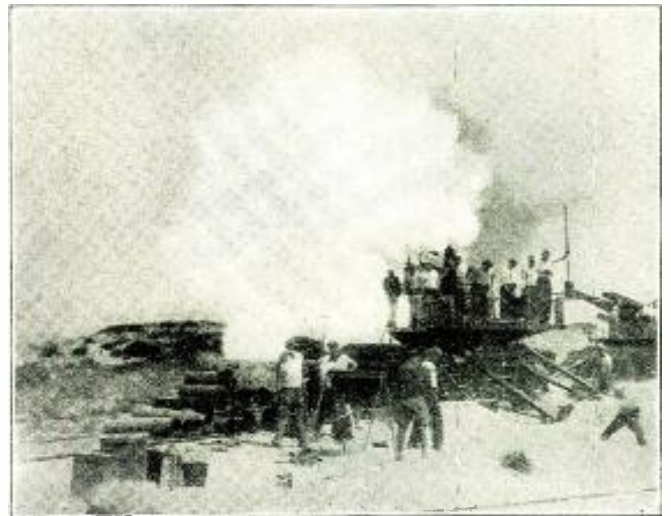

Wide World Photo

The 52nd Coast Artillery firing one of the new "G. P. F. Rifles" during the battle manoeuvres at Fort Story, Virginia Beach

Hardest Compound Cuts "Uncuttable" Metals

TUNGSTEN carbide, the hardest compound known to science, and for years a mere curiosity, has now begun to find extensive commercial use. With it, hard alloys, such as manganese steel and armor plate, can be machined in lathes, planers and shapers, says Dr. Samuel L. Hoyt, of the General Electric Co., in a report to the Engineering Foundation, soon to be published in "Research Narratives."

One of the constituents of this remarkable substance is tungsten, the familiar metal of which the filaments of our electric lamps are made. Though years of research resulted in a process of making tungsten so soft that it could be drawn into fine wires, when combined with carbon, it makes a substance second in hardness only to the diamond. Tungsten carbide will scratch a sapphire, second hardest natural mineral.

Tell 'Em You Saw It in the Citizens Radio Call Book Magazine and Scientific Digest

Commercial Radio Station Checks Time of Earthquakes

THE dots and dashes of radio transmission from an ordinary commercial station are now checking the times of southern California earthquakes. At the Seismological Laboratory of the California Institute of Technology at Pasadena, the code messages from the station are continually received, and recorded by a flashing light on a revolving sheet of photographic paper. An accurate clock is recorded on the same sheet, so that the exact time of any dot or dash may be determined.

Scattered throughout southern California are a number of other seismograph stations, co-operating with the central station. At each of these is a similar automatic radio recorder, continually taking down the messages of the station. A clock, in which accuracy is not essential, records its ticks on the same sheet with the radio records. The same clock makes similar marks on the sheet on the seismograph drum, where the earthquakes are recorded.

In use, this permits the seismologists to tell the exact time at which the earthquake waves reach any station. For instance, suppose an earthquake record begins while the station is sending the word "ship." At Pasadena the record starts on the letter "s," while at Santa Barbara it begins on the letter "h." As the signals arrived at both stations simultaneously, the difference is due to the greater time it takes the wave to travel to Santa Barbara, and from the records of the standard clock at the central station this time may be precisely measured.

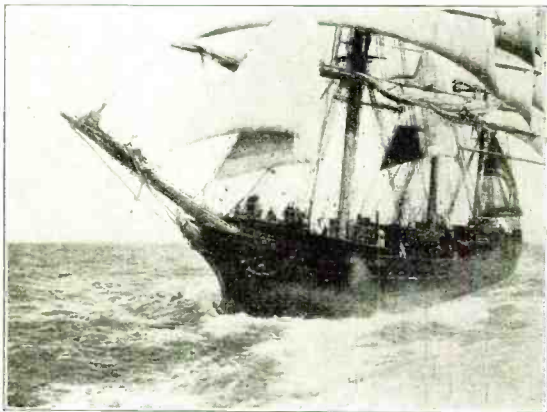

Wide World Photo

The "Star of Alaska" passing through the Golden Gate on her last voyage with the salmon fishing fleet in Alaska, which now numbers but two of the old sailing ships of the days before steam took their place

Ultraviolet Windows Tested by Government

HOW to let the ultraviolet rays of the sunlight through the window into home and schoolroom was discussed by Dr. W. W. Coblenz, physicist of the U. S. Bureau of Standards at Washington, in a report to the Illuminating Engineering Society. He reported his tests upon various window glasses and other materials and suggested that for effective results the material should not transmit less than 45 to 50 per cent of the ultraviolet rays in the sunlight.

Various commercial makes of glasses, after being stabilized by exposure to sunlight, ranged from only one-half to one per cent to 59 per cent transmission, with four out of nine greater than 40 per cent. Dr. Coblenz used a wave length of 302 millimicrons as a division point between the ultraviolet rays and the rest of the sunlight.

EXCELLO Radio Consoles

For Beauty and Distinction

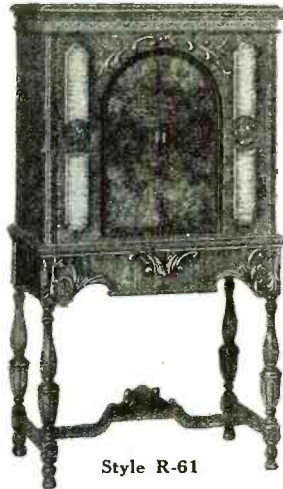

Style R-61

WITH quality and refinement of design, materials and craftsmanship, Excello Consoles incorporate unusual technical skill in meeting all conditions contributing to excellence of reception.

Excello Products Corporation
4820-28 W. 16th Street
Cicero, Ill.

FREE 148 Page Book of BARGAINS - Everything in RADIO

OUR IMMENSE STOCK

on display in this 148-page book. Our large radio store offers you bargains in complete sets as low as \$15.95. Send for this 1930 catalog of beautiful consoles, accessories, parts, kits and the new, humless, Screen Grid, A. C. all-electric sets.

CHICAGO SALVAGE STOCK STORE
509 So. Wabash Ave., Dept. 131
CHICAGO

Choice of 1200 Newest RADIO VALUES



SEND for our 1930 Wholesale Catalog. Filled with exceptional values in parts, kits, short wave kits, screen grid radios, push pull audio radio and consoles.

FREE CATALOG Guaranteed Merchandise at Wholesale Prices

WESTERN RADIO MFG. CO.
"The Big Friendly Radio House"
128 West Lake Street Chicago, Ill.

Tell 'Em You Saw It in the Citizens Radio Call Book Magazine and Scientific Digest

BUILT TO GIVE PERFORMANCE-PLUS!

The NATIONAL Velvetone Amplifier Power Supply is an RCA licensed push-pull power amplifier, sold completely wired, and designed for finest performance with the MB-29. Write today for complete information.

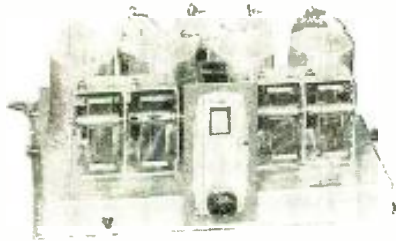

4 SCREEN-GRID Tubes for utmost sensitivity and distance.—a newly designed system of Power Detection necessary to get the most out of the modern high-percentage-modulation broadcasts.—Band-Pass Tuning for complete separation of stations without any cutting of side-bands.—these are only three of the outstanding features of the new NATIONAL MB-29 Tuner.

The shielded aluminum chassis, precision matched

coils, new NATIONAL Projector Dial and Weld-Built Condensers, all make possible the construction of an A. C. Receiver which combines the clean-cut finish and appearance of the finest factory-built model with the quality and perfection of a custom-built job.

There are available a selection of beautifully finished and specially priced consoles and tables for housing the MB-29, in various popular combinations.

NATIONAL SCREEN-GRID

NATIONAL COMPANY INC.
ENGINEERS AND MANUFACTURERS
61 SHERMAN ST., MALDEN, MASS.

Est. 1914 W. A. Reedy, Pres.

MB-29

NOW OPEN
in New York
The HOTEL
GOVERNOR CLINTON
OPPOSITE PENNSYLVANIA R. R. STATION

New York's new hotel truly expressive of the greatest city. 1200 pleasant rooms each with Servidor, bath, circulating ice water and radio provisions.

Rooms from **\$3.00**

General Manager
E. G. KILL

31ST STREET **7TH AVENUE**

The Celotex Theatre Horn

THE non-resonant characteristics of the CELOTEX THEATRE HORN permits a quality of reproduction that is startling in its reality. There is an entire absence of echoing and reverberation, which gives a fidelity to the original tone that has never before been attained where a directional horn has been used.

List Price, \$68.00

Write us for Our **JOBBER'S Proposition**

BAFFLE BOARD CO. 624 Madison Avenue, New York City, N. Y.

FREE RADIO BOOK **WHOLESALE PRICES**

WHOLESALE PRICES

Tremendous stock and sales volume, with rapid turn-over to the thousands of radio dealers we serve enable us to quote the lowest wholesale prices on standard sets and parts. New, humless, Screen Grid, A. C. all-electric sets. Write for latest, new illustrated Catalog "C-1."

ALLIED RADIO CORPORATION
711 W. LAKE ST. CHICAGO

Tell 'Em You Saw It in the Citizens Radio Call Book Magazine and Scientific Digest

CLAROSTAT

Not merely a product; nor again an entire line of products; nor still again a resistance for every conceivable purpose. More than all that, it is the name of a service dedicated to

Aids to Better Radio

ranging from improved wave interception to detector action, radio and audio amplification, volume control, tone quality and all manner of new and experimental applications.

WRITE for data on Clarostat line or ask your dealer about it. Better still, send 25c in stamps or coin for "The Gateway to Better Radio."

CLAROSTAT MFG. CO., Inc.

SPECIALISTS IN RADIO AIDS

285 North 6th Street :: Brooklyn, New York

IN PHILADELPHIA

The **Hotel PENNSYLVANIA**
39th AND CHESTNUT STS.

600 FINE, LARGE OUTSIDE ROOMS
EACH WITH BATH from \$3.00 DAILY



UNRESTRICTED PARKING
SPLENDID RESTAURANTS
CHOICE LOCATION,
NEW and MODERN

Wavy Line Reveals Musicians' Faults

TEACHING singers and other musicians their art by showing them their defects visually, may now be possible with a device demonstrated by Westinghouse engineers. It is called the "projection osiso," and was developed by C. Anderson, of the Westinghouse laboratory at Newark, in conjunction with W. B. White, acoustic engineer of the American Steel and Wire Co. The sound waves are picked up by a microphone, the currents are amplified and cause oscillations in a tiny mirror. A spot of light is reflected from the mirror to a revolving mirror, which reflects it to the screen, where it appears as a straight or wavy line, according to whether or not any sound enters the microphone.

For some years similar methods have been used for sound analysis. In the National Academy of Sciences, in Washington, there is a device of this kind. For six years it has been one of the most popular of the Academy's exhibits. Visitors speak into a mouthpiece, and directly above it a quivering spot of green light traces out the forms of the sound waves of their voices. Another instrument for the same purpose, called the phonodeik, was invented by Dayton C. Miller, of the Case School of Applied Science, in Cleveland, and used by him during the war to study the sound vibrations from big guns. Later he used it for studying voices of singers, and the sounds from musical instruments.



Wide World Photo

With the perfection of the "automat" feeder, which purveys food from any angle and leaves the infant's hands free, the possibility of baby's nursing bottle slipping from tiny hands and crashing to the floor is eliminated

One suggested use of the new instrument is in teaching. Photographs can be made of the sound waves of expert musicians, and the student, with these before him beside the osiso screen, can seek to imitate them. As an illustration of the value of the instrument, it was stated that one pianist found, with its aid, that he could play a single note with 18 different gradations.

Radio Absolved as Weather Disturber

THE rush of radio waves through the ether has not made Paris hotter or colder, dryer or rainier than in the years before the invention of wireless, Joseph Sanson, French engineer and meteorologist, has concluded as a result of a study of weather records for the past two centuries. To determine the validity of claims that radio does influence weather he traced unusual weather and found that for France, at least, the same sort of irregularities were present in past years as have been evident in the decade since the wide use of wireless.

FREE 148 Page Book of BARGAINS - Everything in RADIO

Astounding Radio Values

Complete sets as low as \$15.95. This is only one of the many radio bargains in our new 1930 catalog just off the press. New, humless, Screen Grid, A.C. all-electric and battery operated sets. Also beautiful consoles, accessories, parts and kits. All at wholesale prices.

CHICAGO SALVAGE STOCK STORE
509 So. Wabash Ave., Dept. 131
CHICAGO

HERE'S YOUR CALL BOOK DECEMBER 1929 ISSUE

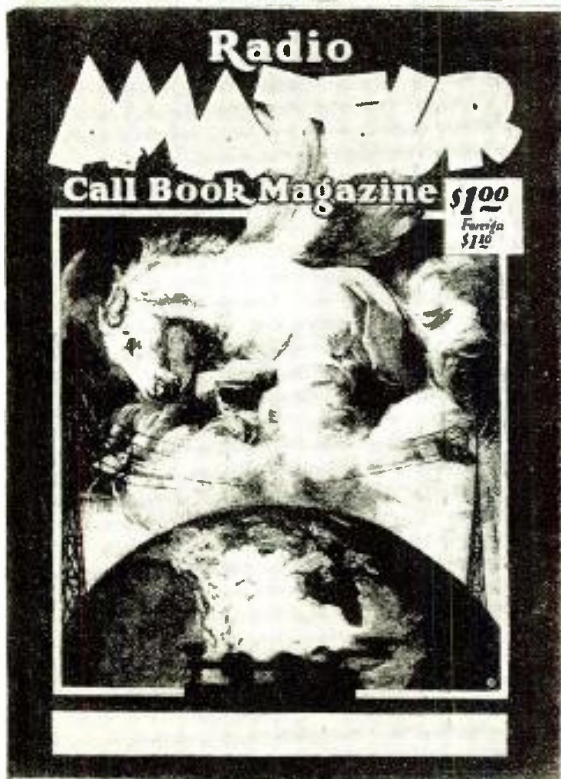

NEW AMATEUR CALLS have been assigned in many countries. Due to the adoption of the new Prefixes, many lists of amateur calls have been changed completely. Radio AMATEUR Call Book for December, 1929, is the ONLY publication giving latest correct information on these calls. The issue also includes hundreds of U. S. and Canadian amateur calls just recently assigned.

We were sold out early on the September issue, so use the coupon and get your big DECEMBER number NOW.

NEW PREFIXES now in use by amateurs in all parts of the world. You need this issue to identify stations heard, as the old Intermediate system has been replaced by the new Prefixes, such as D, OA, X, ZS, etc. We have the most complete list published.

WHO'S WHO ON SHORT WAVES

A brand new section, giving frequency, call, and location of commercials, shortwave fones, television stations, etc., to be heard between 3,000 and 30,000 Kilocycles. Amateur bands are shown in heavier type, so that you can quickly find stations heard above and below the various bands.

Lists published elsewhere are no longer reliable, due to many changes in call letters and shifting of commercial frequencies. This is THE LIST you have been waiting for, giving hundreds of stations heard nightly all over the world.

Radio AMATEUR Call Book, Inc.
508 S. Dearborn St., Chicago, Ill.

Here's my \$3.25 (Outside U. S. and Canada \$3.50) for the September, December, 1929, March and June, 1930, numbers. Single copies \$1.00 (Foreign \$1.10).

Name Call

Street

City State



False Economy Is Costly

Nothing is likely to prove as costly as a cheaply made, over-rated condenser or resistor.

Whether you are a manufacturer, professional set builder or experimenter, you cannot afford the high cost of a cheap condenser or resistor.

Aerovox condensers and resistors are conservatively rated and thoroughly tested. They are not the most expensive, nor the cheapest, but they are the best that can be had at any price.

A Complete Catalog with illustrations and detailed descriptions may be obtained free of charge on request.



The Aerovox Research Worker is a free monthly publication that will keep you abreast of the latest developments in radio. Your name will be put on the mailing list free of charge on request.

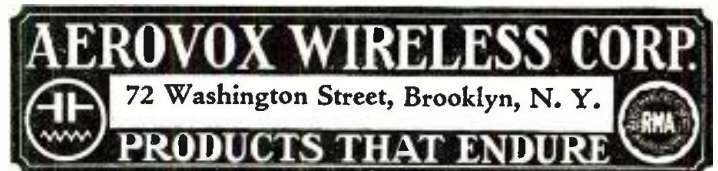

SAVE MONEY ON RADIO!

**We Offer Big Bargains
On Nationally Known Products!**

WHOLESALE PRICES on nationally-known merchandise! Biggest discounts on standard equipment. TREMENDOUS SAVINGS. Everything shown in our newest 1930 Catalog—just out! *Nothing to compare with it!* Immediate personal service on all your orders.

LAFAYETTE SCREEN GRID RECEIVER

A Sensation!

30-Day Free Trial!

The 1930 Lafayette Screen-Grid Radio Set is the sensation of the field. We offer you an opportunity to sell this tremendously popular receiver to people who want the finest in radio. Most liberal discounts to dealers and agents. Because of the tremendous demand for the Lafayette it sells at a price amazingly low.

The 1930 Lafayette has every new feature of radio construction. All Electric Volume Screen-Grid Selectivity 245-Push Pull Amplification Illuminated Single Dial Control Clearest Reception of Any Set on the Market! 30 Different Cabinet Models. Finest custom-built work. AND—A 30-DAY FREE TRIAL ON EVERY LAFAYETTE SET. UNCONDITIONALLY GUARANTEED!

NEWEST 1930 CATALOG

Get Yours Free—Mail Coupon!

DEALERS—AGENTS—Mail the coupon below AT ONCE for your FREE copy of the new 1930 Wholesale Radio Service Catalog. See our money-saving bargains—beautifully reproduced in color. Over 200 pages of big specials. You buy under our "Satisfaction or money back guarantee." Get your copy today. *Rush coupon!*

Mail to: **WHOLESALE RADIO SERVICE COMPANY**
36 Vesey Street, Dept. B-19, New York City

Name.....

Street.....

Town..... State.....

Tell 'Em You Saw It in the Citizens Radio Call Book Magazine and Scientific Digest



**Whatever Your Requirements
Here Are Sockets and Adapters That
Will Meet Your Needs
Which Shall We Send You?**

ADAPTERS

GROUP A—Adapters for Adapting Any Tube to Any Socket

- 419X For adapting UX199 Tubes to UV201A Sockets
- 421X For adapting UX Tubes to WD11 Sockets
- 429 For adapting UV199 Tubes to UV201A and UX Sockets
- 967 For adapting UV201A Tubes to UX Sockets
- 968 For adapting WD11 Tubes to UX Sockets
- 999 For adapting UX Tubes to UV199 Sockets

GROUP B—Connectorails for Adding Power Tubes to Any Set

- 112 For using 112 or 171 Tubes in Battery Sets with UV201A Sockets
- 120 For using 120 Tubes on sets converted from UV201A to 199 Dry Cell Tubes
- 171 For using 112 or 171 Tubes in battery sets with UV201A or UX Sockets
- 420 For using 120 Tubes in sets with 199 tubes and limited headroom
- 920 For using 112, 120, 171 Tubes in sets with UV199 Sockets

GROUP C—Adapters for Converting Battery Sets to A. C.

- 926GT (Orange) Adapter with Bypass Condensers and Y Tap Resistor for Power Tube
- 926 (Red) Adapter with Bypass Condensers and Y Tap Resistor for Audio Tube
- 927UY Adapter for 1Y227 Detector Tubes with leads to Heater Prongs

GROUP D—Adapters for Electric Pickup

- 949 Universal for connecting Electric Pickup fitting either four or five prong tubes into grid circuit (As illustration of 949 reversed) For connecting Electric Pickup to plate circuit of A. C. or D. C. Sets.
- 946 For connecting Electric Pickup to plate circuit of D. C. Sets
- 948 For connecting Electric Pickup with plate circuit of A. C. Sets
- 950 For connecting Electric Pickup with grid circuit of A. C. or D. C. Sets
- 951 For connecting Electric Pickup with grid circuit of D. C. Sets

GROUP E—Adapters for Connecting Power Amplifiers to Any Set

- 933 Adapter for attaching A. C. Sets to Power Amplifiers or Electric Phonographs
- 947 Recommended by Victor for connecting Radiola 16 to Electrola Power Amplifier
- 952 Recommended by Samson for connecting PAM Amplifiers to A. C. Sets (no R. F. Bypass Condenser)
- 952A Recommended by Samson for connecting PAM Amplifiers to A. C. Sets with R. F. Bypass condenser
- 953A Recommended by Samson for connecting PAM Amplifiers to D. C. Sets with R. F. Bypass Condenser
- 953 Recommended by Samson for connecting PAM Amplifiers to D. C. Sets (no R. F. Bypass Condenser)

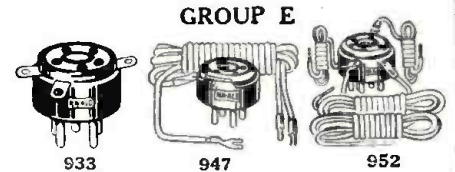

GROUP E

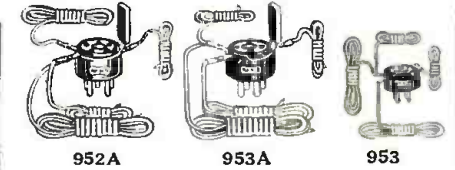

GROUP F

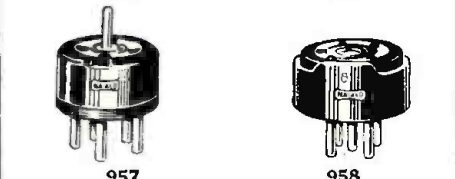

GROUP G

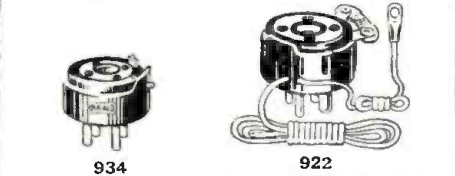

GROUP G—Miscellaneous Adapters

- 944E 4 hole, 4 prong adapter 7/8 inches high with all connections through
- 944 (Not illustrated) as 944E except 3/4 inches high
- 956E 5 hole, 5 prong adapter 7/8 inches with all connections through
- 955 (Not illustrated) as 956E except 3/4 inches high
- 921s For cushioning microphonic tubes in either UX or UV201A Sockets
- 934 Adapter with grid resistor for oscillation control
- 922 For adapting any socket for UX222 Shielded Grid Tube

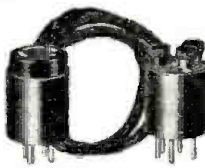

Special Adapter Made for Victor

GROUP F—Adapters Especially for Set Analyzers and Testing Equipment

- 932 Twin Adapter for testing UX222 Shielded Grid Tubes in Jewell Testers
- 942 Twin Adapters for testing 5 prong A. C. Tubes in Jewell Testers
- 957 Weston 4 hole, 5 prong Adapter with top center stud
- 958 Weston 5 hole 4 prong Adapter with extra center prong
- 945 For adapting 4 prong UX Tubes to 5 prong UY Sockets
- 954 For adapting 5 prong UY Tubes to 4 prong UX Sockets

SOCKETS

- 400 DeLux Socket with neck and slot for Bayonet Pin
- 422 NA-ALD Small Space 4 prong Socket for below panel soldering
- 423 NA-ALD Small Space 5 prong Socket for below panel soldering
- 424 NA-ALD 4 prong Socket with 2 mounting holes for above or below panel mounting, below panel soldering
- 425 NA-ALD 5 prong Socket with 2 mounting holes for above or below panel mounting, below panel soldering

SOCKETS

- 426 NA-ALD 4 prong A. C. Socket, UX type, with contacts for above panel soldering
- 427 NA-ALD 5 prong A. C. Socket, UX type, with contacts for above panel soldering
- 428 NA-ALD 4 prong Small Space Socket especially for Rectifier Tubes, for above panel soldering
- 481XS NA-ALD 4 prong Microphone Socket with mounting base
- 482S NA-ALD 4 prong Microphone Socket for direct panel mounting



482S

Dept. C **ALDEN MANUFACTURING CO.** Brockton, Mass.



400



422



423



424



425



426



427



428



481SX

Tell 'Em You Saw It in the Citizens Radio Call Book Magazine and Scientific Digest

LEARN TELEGRAPHY WITH TELEPLEX

Be an expert Morse or Continental Code Operator. **BIG PAY—TRAVEL—FUN—ADVENTURE!** After a few short weeks of practical study with Teleplex you will be an expert operator. This amazing instrument teaches you right in your own home. Works like a phonograph. No knowledge needed—beginners learn **AT ONCE! NOT A SCHOOL.**

FREE 10 DAYS TRIAL: Try the Teleplex right in the privacy of your own home. Convince yourself that you can learn the code. We give you 10 days **FREE TRIAL.** Send for full details **AT ONCE!**

TELEPLEX COMPANY, 72 Cortlandt Street, Dept. A-16, New York, N. Y.



ARE YOU TRAVELING



to **Chicago, St. Louis, Detroit, Philadelphia or Boston?**

Be assured of pleasant hotel accommodations, suiting your requirements, at attractive rates in above cities. Write, stating number in party, date of arrival and sort of accommodations required—full information, including motor route if requested, will be sent without charge. Avail yourself of this free service today.

Representing Hotels of Outstanding Merit

- | | |
|------------------|---------------------------|
| CHICAGO | DETROIT |
| The GRAEMERE | The GREATER |
| The ALBION SHORE | WHITTIER |
| The EMBASSY | The GRANT |
| The CHURCHILL | PHILADELPHIA |
| The MARTINIQUE | MAYFAIR HOUSE |
| The SHOREHAM | BOSTON (Brookline) |
| The WASHINGTON | LONGWOOD |
| ST. LOUIS | TOWERS |
| The ROOSEVELT | |

AFFILIATED HOTELS BUREAU
Room 1001, 127 N. Dearborn St.
CHICAGO

GUARANTEED RADIO SERVICE

Repairing—Testing—Designing and Electrifying

WE are completely equipped to repair and test any make Receiver or Power Device. Our high class workmanship, together with modern testing equipment, enables us to rapidly locate the defects involved in your receiver in a scientific manner. *All work is guaranteed* and our charges are no more, than paid for inferior workmanship.

Dealers, Jobbers and Manufacturers—Let us give you an estimate for repairing and servicing all your defective radio apparatus. Our prices are low and the workmanship is of the highest class obtainable.

RADIO SERVICE LABORATORIES, Inc.
440 So. Dearborn St. Phone: Harrison 2870 Chicago, Ill.

Essential to
MODERN RADIO!

ENJOY steady radio reception with uniform volume—clear and sweet—undisturbed by the ever-changing quality of your house electric supply. Makes tubes last longer and perform better. Saves money.

AMPERITE Corporation
561 BROADWAY, NEW YORK



AMPERITE
Self-Adjusting
LINE VOLTAGE CONTROL

DEMAND AMPERITE
in the radio you buy or build. No radio can be modern without AMPERITE.

Write Dept. CR11 for **FREE Illustrated Folder**

Ready Now!

A "BINKS QUALITY" Small Spray Unit

for only **\$59.50 COMPLETE**



BINKS NEW "HURLEY" UNIT

It's here—a smaller model of the famous Binks Portable Industrial Spray Units—combining the utmost in efficiency, durability, portability, economy and convenience—and of the same rugged, dependable quality which has characterized all Binks Products for over thirty years.

Developed and perfected to supplement our larger spray units, the "Hurley" does real professional work, yet because of its weight (only 47 pounds) it is easily carried to any job. At its low price—made possible by production on a large scale basis—it represents the outstanding value in spray equipment today. Just think of it—a real, pressure spray outfit with a Binks New Pressure Cup Spray Gun giving a 4-inch flat spray, a full quart size all steel patented leak-proof container, and a 1/4 H. P. General Electric Motor for only \$59.50 complete.

Write today for descriptive folder giving complete specifications

BINKS MANUFACTURING COMPANY
3104 Carroll Avenue Chicago, Ill.

FREE RADIO CATALOG

THE NEW SCREEN GRID RECEIVERS

WHOLESALE PRICES

Here is the most up-to-date stock of parts, accessories and sets—including the new Screen Grid, A. C. all-electric sets. Write for Catalog "C-1" quoting special wholesale prices.

ALLIED RADIO CORPORATION
711 W. LAKE ST. CHICAGO

OUR DRAFTING ROOM



This staff of highly trained draftsmen is continually preparing the most accurate and complete full size blue prints of radio receivers and power packs obtainable.

Blue prints are available on all circuits described in the CALL BOOK. Each set of prints is composed of all the necessary drawings prepared in such complete detail and accuracy as to enable an inexperienced builder to duplicate in every respect the receivers built in our laboratory, thus assuring positive success and the greatest satisfaction.

PLEASE ORDER BLUE PRINTS BY NUMBER AND NAME

No. 12	Madison-Moore Super-heterodyne Receiver using 201-A Tubes.....	\$1.00	No. 123	World's Record Super Ten & Power Pack (6 drawings).....	\$1.00
No. 14	Browning-Drake 4 Tube Receiver Using Audio Frequency Amplification.....	1.00	No. 147	Custom-built Model Madison-Moore International One-Spot A. C.—Sub-panel Job (6 drawings).....	1.00
No. 32	Scott "World's Record" Super Eight.....	1.00	No. 162	National Screen Grid Five (5 drawings).....	1.00
No. 37	Madison-Moore "One-Spot" Receiver.....	1.00	No. 167	Scott World's Record SG Nine "Power Pack Operated" (4 drawings).....	1.00
No. 50	Improved Browning-Drake.....	1.00	No. 172	Remler 1929—115 K. C. SG Super (3 drawings).....	1.00
No. 58	"World's Record" Super Nine.....	1.00	No. 179	Lincoln 8-30 One-Spot Super—(3 drawings).....	1.00
No. 64	Aero Seven Tube T. R. F. Receiver (5 drawings).....	1.00	No. 198	Tyrman 72 A. C. Super.....	1.00
No. 68	Improved Remler 45 K. C. Super-heterodyne Receiver (5 drawings).....	1.00	No. 218	Aero International Four Receiver (4 drawings).....	1.00
No. 73	Magnaformer Super-heterodyne Receiver (5 drawings).....	1.00	No. 226	Hammarlund-Roberts Hi-Q 29 Receiver, Master A. C. model (5 drawings).....	1.00
No. 79	Silver-Marshall High Amplification Super-heterodyne Receiver (5 drawings).....	1.00	No. 231	Custom-built Model World's Record Shield Grid A. C. 10 (4 drawings).....	1.00
No. 93	Kuickerbocker Four (5 drawings).....	1.00	*No. 241	Capacity Bridge (3 drawings).....	1.00
No. 99	Magnaformer 9-8 A. C. (5 drawings).....	1.00	*No. 246	Pilot Super-Wasp Short Wave Receiver (3 drawings).....	1.00
No. 115	Tyrman Amplimax "70" Shielded Grid (6 drawings).....	1.00			

GRAPHIC WIRING DIAGRAMS

No. 20	Silver-Marshall Improved 7 Tube Super-heterodyne Receiver.....	\$0.60	No. 195	Junior 2 Tube Receiver.....	\$0.10
No. 101	World's Record Economy Super 8.....	.60	No. 196	Aero A. C. Short Wave Converter.....	.60
No. 134	Nine-in-Line A. C. Operated.....	.60	No. 200	Silver-Marshall Phonograph Amplifier.....	.60
No. 136	Citizens Crystal Receiver.....	.60	No. 202	Silver-Marshall 730 Four Tube Receiver.....	.60
No. 154	Silver-Marshall 4 Tube Shield Grid Receiver.....	.60	No. 204	Sanzamo Push-Pull Lab. Amplifier.....	.60
No. 160	Thordarson 210 Power Compact.....	.60	No. 210	Silver-Marshall 6 Tube Receiver (using output choke).....	.60
No. 165	Citizens SG Booster Stage.....	.60	No. 213	Junior 4 Tube Receiver.....	.10
No. 166	Silver-Marshall SG Six (no output choke).....	.60	No. 221	Modulated Oscillator.....	.60
No. 170	Silver-Marshall SG Super Nine.....	.60	No. 225	Silver-Marshall 720 A. C. Shield Grid Six.....	.60
No. 174	Sargent-Rayment Seven Receiver.....	.60	No. 225	Hollister A. C. Super Eight.....	.60
No. 178	Silver-Marshall 731 Short Wave Adapter.....	.60	No. 236	S-M 722 A. C. Screen Grid Receiver.....	.60
No. 182	Hallardson A. C. 56—T. R. F.....	.60	No. 237	S-M 735 Short Wave Receiver, A. C.....	.60
No. 183	National Short Wave Receiver.....	.60	*No. 242	National Screen Grid MB-29 Receiver.....	.60
No. 185	Silver-Marshall "Coast to Coast" Four.....	.60	*No. 244	S-M S. G. A. C. 712 Rec. (to be used with 677 Power Pack).....	.60
No. 187	Citizens Special Short Wave Receiver.....	.60	*No. 245	S-M 677 Power Pack (to be used with 712 Receiver).....	.60

SCHEMATIC WIRING DIAGRAMS

No. 164a	Thordarson 250 Power Supply and Amplifier.....	\$0.50	No. 223a	Silver-Marshall 720 A. C. Shield Grid Six.....	\$0.50
No. 170a	Silver-Marshall SG Super Nine.....	.50	No. 225a	Hollister A. C. Super Eight.....	.50
No. 171a	Thordarson Dealer's Amplifier.....	.50	No. 233a	Keystone Electric 67 Receiver Kit.....	.50
No. 174a	Sargent-Rayment Seven Receiver.....	.50	No. 234a	HFL Mastertone Receiver, A. C.....	.50
No. 183a	National Short Wave Receiver.....	.50	No. 236a	S-M 722 A. C. Screen Grid Receiver.....	.50
No. 185a	Silver-Marshall "Coast to Coast" Four.....	.50	No. 237a	S-M 735 Short Wave A. C. Receiver.....	.50
No. 187a	Citizens Special Short Wave Receiver.....	.50	No. 238a	Lincoln 8-40 Screen Grid A. C. Super.....	.50
No. 191a	Scott World's Record SG Nine "Battery Operated".....	.50	No. 239a	C. R. Leutz "Seven Seas" Console Receiver.....	.50
No. 196a	Aero A. C. Short Wave Converter.....	.50	No. 240a	Remler Type 111 Screen Grid Receiver and Amplifier.....	.50
No. 197a	Aero A. C. 21 (Heterophase Receiver).....	.50	*No. 242a	National Screen Grid MB-29 Receiver.....	.50
No. 202a	Silver-Marshall 730 4 Tube Receiver.....	.50	*No. 243a	Citizens 3 Tube Rec. using 224 Tube as Power Detector.....	.50
No. 203a	HFL Special Nine A. C. Super.....	.50	*No. 244a	S-M S. G. A. C. 712 Rec. (to be used with 677 Power Pack).....	.50
No. 211a	Magnaformer 1929 A. C. Super.....	.50	*No. 245a	S-M Power Pack (to be used with 712 Receiver).....	.50
No. 220a	Thordarson R-480 Power Amplifier (171 Push-Pull).....	.50	*No. 249a	Hammarlund-Roberts Hi-Q 30.....	.50
No. 221a	Modulated Oscillator.....	.50	*No. 250a	Braxton-King A. C. S. G. Super Model A.....	.50

FACTORY BUILT RECEIVER SCHEMATICS

No. SR 1	All-American Mohawk 6 and Power Supply.....	\$0.50	No. SR14	Freshman 2-N-12 and Power Unit.....	\$0.50
No. SR 2	All-American Mohawk 8 and Power Supply.....	.50	No. SR15	Stefinite Model 261 and Supply.....	.50
No. SR 3	Acme A. C. 7 and Power Supply.....	.50	No. SR16	Howard Green Diamond Set, Model 8.....	.50
No. SR 4	Acme A. C. 4 and Power Supply.....	.50	*No. SR17	Grebe Synchrophase 7 A. C. Set.....	.50
No. SR 5	Crosley Gembox A. C. Model 608 and Power Pack.....	.50	*No. SR18	Stromberg-Carlson 635-636 Receiver.....	.50
No. SR 6	Crosley D. C. Showbox, Model 705.....	.50	*No. SR19	Federal Model "H" A. C. Receiver.....	.50
No. SR 7	The Majestic Receiver, Model 70.....	.50	*No. SR20	Freed-Eisemann NR-80 and Supply.....	.50
No. SR 8	Kolster 4 Tube Chassis and Supply.....	.50	*No. SR21	Bosch Model 28 and 29.....	.50
No. SR 9	Spartan A. C. 80 Receiver and Pack.....	.50	*No. SR22	Amrad Model 70 A. C. Receiver.....	.50
No. SR10	Bremer-Tully Model 7-70 and Supply.....	.50	*No. SR23	Brunswick No. 3KRO Receiver.....	.50
No. SR11	DayFan 5080 Receiver and Supply.....	.50	*No. SR24	A. C. Dayton Navigator.....	.50
No. SR12	Balkite Model A Receiver and Pack.....	.50	*No. SR25	Sonora DeLuxe Model 5-R Receiver.....	.50
No. SR13	Fada 7 A. C. Model and Type C Unit.....	.50	*No. SR26	Philco Model 86 and 82 Receiver.....	.50

* Circuits described in Present issue.

Any of the above blue prints will be sent postpaid by return mail upon receipt of the proper amount or they can be obtained from any of the Radio jobbers advertising in this publication. C. O. D. orders not accepted.

CITIZENS RADIO SERVICE BUREAU 508 SOUTH DEARBORN STREET 7TH FLOOR—CHICAGO, ILLINOIS

Tell 'Em You Saw It in the Citizens Radio Call Book Magazine and Scientific Digest

LOWER RATES
When You Go To
CLEVELAND

EVERY ROOM WITH BATH
NOW **\$2** **\$2.50** **\$3**

300 Clean Modern Rooms



HOTEL AUDITORIUM
EAST SIXTH AT ST. CLAIR AVE.
W. H. BYRON, Manager



There's an air of hospitality that you'll like
AT THE HOTEL
PICCADILLY
227 WEST 45th ST. OF BROADWAY
NEW YORK

ADJACENT TO EVERY ACTIVITY
600 BRIGHT SUNLIT ROOMS
→→→ EACH WITH BATH, ←←←
ELECTRIC FAN, ICE WATER
SINGLE ROOM ^{no} BATH \$3.00
DOUBLE ROOM ^{no} BATH \$4.50
EXCEPTIONAL RESTAURANT and GRILLE
WIRE AT OUR EXPENSE FOR RESERVATIONS
F. D. SOFIELD - MANAGING DIRECTOR

**Tune in
on
This**



**New
RADIO COURSE**

IT PROVIDES an easy way to prepare for a good position in radio work. It furnishes a broad knowledge of radio that applies to the job at hand whether that job be the simple act of removing a tube or figuring on the most modern installation. It explains the technicalities of radio in clear, understandable language, first laying a fine mathematical background.

There is no better way for you to succeed in radio than to study this new course of the International Correspondence Schools. Every day new students are finding that out. The course is endorsed by leading radio experts and radio manufacturers.

Mark and mail the coupon today and let us tell you what it can do for you.

Mail the coupon for FREE booklet

INTERNATIONAL CORRESPONDENCE SCHOOLS
Box 8318-D, Scranton, Penna.

Without cost or obligation, please tell me all about the
NEW RADIO COURSE

Name _____
Street Address _____
City _____ State _____

Electrify Your Radio for Only \$6.85
Townsend "B" Power Unit COMPLETE

Why discard your present good set when you can electrify it for only \$6.85, and banish the annoyance and expense of buying new "B" batteries?



Over 150,000 Townsend "B" Power Units Now in Use

Hooked up in a few minutes. Use same tubes—no changes. You'll be amazed at the improvement in reception and distance getting. Send name and address today for full details, proof and Free Trial Offer.

TOWNSEND LABORATORIES, 726 Townsend St., Chicago

Tell 'Em You Saw It in the Citizens Radio Call Book Magazine and Scientific Digest

Classified Advertisements

Advertisements in Classified Section, 25 cents per word each insertion, minimum 10 words, payable in advance. Final closing dates, Aug. 10, for September issue; Oct. 10, for November issue; Dec. 10, for January issue; Feb. 10, for March issue. No display or all caps copy accepted.

GUARANTEED Service on all makes of Radio Sets, Power Amplifiers, Power Units, Authorized Sales and Service Station for Scott World Record, H. F. L. Masterton and Silver-Marshall Radio Products, Reasonable Prices. Astland Radio Laboratories 411 So. Astland Blvd., Chicago, Ill. Phone Hammarket 5826.

WANTED—Men to work with National Radio Service organization. No selling scheme. Radio Doctors, Inc., Dept. C, Essex St., Salem, Mass.

DIES—Light stampings. R. L. Nortwed, Mitchell, South Dakota.

REMARKABLE! New! Phantom Aerial, Eliminates outside aerial. Wonder for distance. Instantly attached. \$2.75 Postpaid. Monarch Radio Corp., 8328 Vernor, Detroit, Mich.

UNUSUAL Horoscope—Consisting of extensive four-page horoscope and Astro Analysis. Send 50c and birth date. Money refunded if dissatisfied. No stamps. Prof. Bolles, Box 125, Cranford, N. J.

ARE you moving to California? We maintain a luxuriously furnished and appointed Hotel Apartment Building. Just a few minutes from the heart of the city. Quiet and cozy. Complete hotel service. Rates are very reasonable: \$25.00 weekly, \$100.00 monthly, for lovely two-room apartment with every convenience. Inspect our apartments before you locate in Los Angeles. El Cortez, 516 W. 31st St., Los Angeles, California.

MEASUREMENT and Calibration Service. Calibration of Amateur Wavemeters: 1 to 5 Points, \$0.50 per point calibrated; 5 to 10 Points, \$0.40 per point calibrated; 10 to 20 Points, \$0.30 per point calibrated; 20 or more Points, \$0.25 per point calibrated. Blueprints of Curves: 1 Blueprint, \$1.00; 2 Blueprints, \$1.50; 3 Blueprints, \$1.75; 4 Blueprints or more, \$0.50 each; Additional Copies, \$0.20 each. Variable Air Condensers: 1 Per Cent Accuracy, \$0.10 per point calibrated; .1 Per Cent Accuracy, \$0.20 per point calibrated; (Ten points per condenser is usually sufficient). Blueprints of Curves: Same as wavemeter curves. Fixed Condensers: Capacity at 1000 cycles, \$0.25 each. Measurement of Fixed and Variable Condensers: Power Factor, Phase Angle and A. C. Series Resistance. Prices on Request. Intermediate Frequency Transformers: Measurement of Resonant Peak Frequency, \$0.75 each; Frequency response and static amplification characteristic curve, \$1.50 each. (I. F. transformers will not be matched). R. F. Transformers: Pure Inductance, \$1.00 each; Apparent Inductance, \$1.00 each; Distributed Capacity, \$1.00 each; Fundamental Frequency, \$1.00 each; Pure Inductance Matched, \$1.00 each; Apparent Inductance Matched, \$0.50 each. Measurement or Calibration of: Voltmeters, Microvoltmeters, Ammeters, Milliammeters and Microammeters. Any type of laboratory or service equipment built to order. The Parkland Laboratories, 1660-62 E. 71st St., Chicago, Ill.

TROUBLE shooting in Superheterodyne Circuits is simplified with the Jensen Super Chart. Practically every known combination is instantly available to locate trouble in this circuit. Costs little—does much. 50c brings the chart, with full directions for its operation. Stamps (U. S.), Coin or Check. Roberts Radio Service, Caxton Bldg., Chicago, Ill.

LEARN the wireless code. Anyone can do it in our evening with the Roberts Short Cut. This system was designed by a former Naval Officer to enable students to master the wireless code in the shortest possible time. No mechanical apparatus needed, just take this short cut and you will be able to read the interesting messages sent from ships at sea and other messages sent in Continental Wireless Code. Failure impossible. The Roberts System costs so little, why not send for it today. 50c Stamps (U. S.), Coin or Check. Short Cut sent postpaid. Roberts Radio, 775 Caxton Bldg., Chicago, Ill.

ENGLAND offers large market for American Radio Merchandise. We are the Largest Distributors of Radio Merchandise in the British Empire and Continental Europe. Manufacturers desiring to offer their products to this fertile field are requested to communicate with E. E. Heaver, Sales Manager, The Rothermel Radio Corporation, Ltd., 24-26 Maddox St., London, W. I.

CATALOG—Write for your copy (1930). Full List, Kits, Parts, Accessories. Low Prices. Nelson Electric Co., 508 S. Dearborn St., Chicago, Ill.

SUPERHETERODYNE for sale. The record breaker Magnaformer 9-8, in beautiful \$200.00 Console (Pier-son), has Thordarson B Eliminator. Complete with Tubes, Loop, Dynamic Speaker. \$500.00 value for best offer over \$150.00. Wonderful value. Will demonstrate. Radio Service Laboratories, 440 S. Dearborn St., (Room 675), Chicago, Ill.

IN TROUBLE—Does your set perform as it should? Our completely equipped Laboratory is at your service and our charges are no more than any repair shop. Why not have your work done by experts with years of experience and a completely equipped laboratory. Correspondence solicited from those who desire to have sets repaired, tested, changed over, revived, rebuilt. Estimate will be given in advance on work required. Radio Service Laboratories, 440 S. Dearborn St., Chicago, Ill.

CUSTOM built radio sets out perform any other type sets on the market. Superheterodynes hold all records for distance and selectivity. Why not get the best? We build any type set or power amplifier to order. Radio Service Laboratories, Inc., 440 S. Dearborn St., Chicago, Ill.

POSTAGE stamps for collections. Interesting and instructive. We have single stamps and small and large collections for sale. Write for catalog. Metropolitan Stamp Co., Coans Theatre Bldg., 42nd and Broadway, New York City.

ARE you building a house? We will show you how to wire same for Radio. Write us your problems—our service department will show you how. Taxley Mfg. Co., attention Mr. Sparrow, 9 S. Clifton St., Chicago, Illinois.

THIS CLASSIFIED SECTION IS A PERMANENT ADDITION TO THIS PUBLICATION

IF you have anything special to sell—a small lot to clean out, or a special story to tell, this section will serve your purpose in the cheapest possible way and bring results that will be amazing.

Next issue on sale, January 1st. Four issues yearly, September, November, January and March.

TRY THIS CLASSIFIED SECTION

The Charge Is Small—The Returns Most Gratifying

Tell 'Em You Saw It in the Citizens Radio Call Book Magazine and Scientific Digest



TELEVISION RADIOMOVIES

POHL Scanning Disks must be right for the FEDERAL TELEGRAPH CO., a number of U. S. RADIO INSPECTORS and many Radio Fans and Experimenters are using them.

- 12" flexible cardboard Scanning Disks ready for 1/4" shaft mounting, mailed anywhere, each\$0.75
- G-10 Neon Lamp75
- Standard Neon Lamp, plate size 1 1/2"x1 1/2"..... 4.50
- Standard Scanning Disks made of 1/16" aluminum.
- 12"with Aluminum flange for mounting on 3/8" shaft, each 6.50
- 12" without mounting, for any size shaft. Mention shaft size, each 5.00

There is no advantage in a larger than 12" disk, as much can be done with a magnifying or reading glass about 3" in diameter which will bring the picture up to this size.

3" Reading Glass, each.....\$1.50
All Scanning Disks can be had with any number of holes on spiral.

You can be sure of a square deal as my slogan is "YOU MUST BE SATISFIED." Prices are low because I do not issue circulars or descriptive matter. The best test is to try them. I am Television-Pioneer-Scanning-Disk-Maker. Remember that the development of Television is dependent on you, Radio Fans, Amateurs and Experimenters of today, who will reap the rewards in this field as future Television Engineers, just as the present Radio Engineers were yesterday's Experimenters, Amateurs and Fans who made radio what it is today.

ARTHUR M. POHL

(Formerly Pohl Brothers)

3541 Michigan Ave. DETROIT, MICH.

STATEMENT OF THE OWNERSHIP, MANAGEMENT, CIRCULATION, ETC., REQUIRED BY THE ACT OF CONGRESS OF AUGUST 24, 1912

OF CITIZENS RADIO CALL BOOK MAGAZINE AND SCIENTIFIC DIGEST, published four times yearly at Chicago, Illinois, for April 1, 1929. State of Illinois, County of Cook, ss.

Before me, a notary public in and for the state and county aforesaid, personally appeared Chas. O. Stimpson, who, having been duly sworn according to law, deposes and says that he is the Editor of the CITIZENS RADIO CALL BOOK MAGAZINE AND SCIENTIFIC DIGEST and that the following is, to the best of his knowledge and belief, a true statement of the ownership, management (and if a daily paper, the circulation), etc., of the aforesaid publication for the date shown in the above caption, required by the Act of August 24, 1912, embodied in section 411, Act of August 24, 1912, printed on the reverse of this form, to wit:

1. That the names and addresses of the publisher, editor, managing editor, and business managers are: Publisher, Citizens Radio Service Bureau, Chicago, Ill.; Editor, Chas. O. Stimpson, Chicago, Ill.; Managing Editor, Fred A. Hill, Chicago, Ill.; Business Manager, D. H. Bell, Chicago, Ill.

2. That the owner is (if owned by a corporation, its name and address must be stated and also immediately thereunder the names and addresses of stockholders owning or holding one per cent or more of total amount of stock. If not owned by a corporation, the names and addresses of the individual owners must be given. If owned by a firm, company, or other unincorporated concern, its name and address, as well as those of each individual member, must be given): Citizens Radio Service Bureau, Chicago, Ill.; Chas. O. Stimpson, Chicago, Ill.; D. H. Bell, Chicago, Ill.; H. Ahlweiser, Chicago, Ill.

3. That the known bondholders, mortgagees, and other security holders owning or holding 1 per cent or more of total amount of bonds, mortgages, or other securities are (if there are none, so state): There are none.

4. That the two paragraphs next above, giving the names of the owners, stockholders, and security holders, if any, contain not only the list of stockholders and security holders as they appear upon the books of the company but also, in cases where the stockholder or security holder appears upon the books of the company as trustee or in any other fiduciary relation, the name of the person or corporation for whom such trustee is acting, is given; also that the said two paragraphs contain statements embracing affiant's full knowledge and belief as to the circumstances and conditions under which stockholders and security holders who do not appear upon the books of the company as trustees, hold stock and securities in a capacity other than that of a bona fide owner; and this affiant has no reason to believe that any other person, association, or corporation has any interest direct or indirect in the said stock, bonds, or other securities than as so stated by him.

5. That the average number of each issue of this publication sold or distributed, through the mails or otherwise, to paid subscribers during the six months preceding the date shown above is (this information is required from daily publications only):

CHAS. O. STIMPSON, Editor.

Sworn to and subscribed before me this 20th day of March, 1929.

(SEAL) NELLIE E. RYAN, (My commission expires July 25, 1932.)

Be a Radio Expert

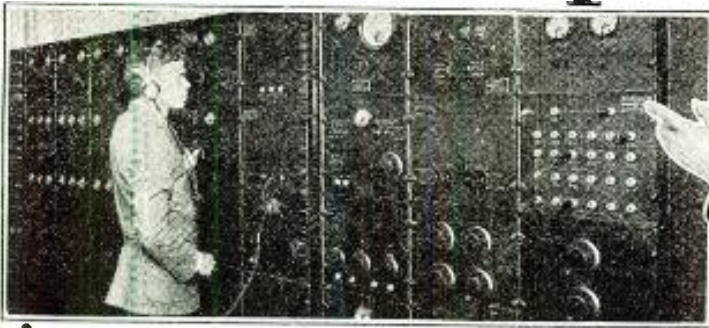

J. E. Smith Pres.

I've trained hundreds of fellows at home in their spare time for Big Pay Radio Jobs.

Look at These Earnings

Has Made \$10,000 More in Radio



"I can safely say that I have made \$10,000 more in Radio than I would have made if I had continued at the old job. When I enrolled with you I didn't know a volt from an ampere. I advise all ambitious young men to get into Radio. There is no greater opportunity."

Victor L. Osgood, 7101 Bay Parkway, Brooklyna, N. Y.

\$500 a Month

"When I enrolled with N. R. I. I was a motorman on a trolley car. Now I have a fine, fast-growing Radio business. I have \$2800 in the bank and about \$300 worth of Radio stock. I made it all since graduating less than six months ago."

Richard Butler, 3535 Sheffield St., Philadelphia, Pa.

\$3,000 a Year

"I cannot give too much credit to the N. R. I. for what I have been able to do in Radio. I have averaged \$3000 a year for the past three years. I am in the Radio business. I consider all the success I have obtained so far due entirely to your training."



Fred A. Nichols, Hereford, Colo.

I give you a home experimental laboratory. You can design and build 100 circuits with it. Here are two ~



This Book Free!



This is Radio's Biggest Year

A great training made greater-Television now included

Television can easily and quickly become as big as the whole Radio field is today. That's why you ought to know all about the different systems for sending and receiving pictures—there are many good jobs right ahead. Jennings, Cooley's, Bell's, Baird's, Bell's, Alexander's methods are covered in our course. Your Radio training will be absolutely complete when you hook up with N. R. I.

Learn at Home

Don't lose a minute from your job. All I ask is part of your spare time. My practical method of training with six big outfits of Radio parts makes learning at home easy, fascinating, a pleasure. Boys 14, men up to 60 have finished my course successfully. You don't need a high school education. Many of my most successful graduates didn't even finish the grades.

You Must Be Satisfied

The day you enroll I'll give you a contract agreeing to refund every penny of your money if you are not satisfied with the lessons and instruction I give you.

Get This Book AT ONCE

"Rich Rewards in Radio" shows where the big jobs are, what they pay, what others are making. It has started hundreds of fellows on the road to bigger money who thought success was not for them. Get a copy. Not the slightest obligation. Do it Now.

J. E. SMITH, President

Dept. 9YDD, National Radio Institute, Washington, D. C.



Mail Coupon NOW

J. E. SMITH, President, Dept. 9YDD, National Radio Institute, Washington, D. C.

Dear Mr. Smith: Send me your book, "Rich Rewards in Radio." I want to know about the money-making opportunities in Radio and your practical method of training men at home in their spare time to become Radio experts. This request does not obligate me.

Name.....Age.....
Address.....
City.....State.....

Tell 'Em You Saw It in the Citizens Radio Call Book Magazine and Scientific Digest

Index to Advertisers

A

Aero Products, Inc..... 2
 Aerovox Wireless Corp.....138-151
 Affiliated Hotels Bureau.....153
 Alden Manufacturing Co.....152
 Allied Radio Corp.....
1-122-142-144-149-153
 American Sales Co.....146
 American Transformer Co..... 29
 Amperite Corporation153
 Arcturus Radio Co.....145
 Aston Cabinet Manufacturers.....137
 Auditorium Hotel155

B

Baffle Board Co.....149
 Best Manufacturing Co.....141
 Binks Mfg. Co.....153

C

Cameradio Co.148
 Central Radio Laboratories.....126
 Chicago Salvage Stock Store.....
138-140-147-148-150-160
 Citizens Radio Service Bureau
 (Blue Prints)154
 Citizens Radio Service Bureau
 (Subscription Offers)31-128
 Clarostat Mfg. Co., Inc.....150
 Classified Advertisements Page.....156
 Cornish Wire Co.....134

D

Drake Hotel, The.....126

E

Electrad, Inc. 11
 Electric Supply Co.....122
 Excello Products Corp.....147
 Expert Radio Shop.....144

F

F & H Radio Laboratories.....137
 Ferranti, Inc.135
 Fort Shelby Hotel.....130
 Frost, Inc., Herbert H.....145

G

General Radio Co.....144
 Governor Clinton, The Hotel.....149

H

Hammarlund Mfg. Co.....131
 Hammarlund-Roberts, Inc..... 23
 High Frequency Laboratories.....139
 Hoodwin Co., Chas.....144

I

Independent Electric Works.....140
 Insuline Corp. of America.....142
 International Correspondence
 Schools155
 International Resistance Co.....133

J

J. M. P. Mfg. Co., Inc.....143
 Jewell Electrical Instrument Co..... 3

L

Leutz, Inc., C. R..... 19
 Lincoln Radio Corp..... 17
 Lund Corp., I. A.....121

M

Magnavox Co., The..... 6
 Marlborough Hotel140
 Midwest Radio Corp.....Third Cover
 Mississippi Valley Radio Co..... 45
 Muter Co., Leslie F.....Fourth Cover

N

National Co., Inc.....149
 National Radio Institute.....5-157
 Nelson Electric Co..... 37
 Newark Electric Co..... 25
 Norden-Hauck, Inc. 33

O

Ozarka, Incorporated 13

P

Pennsylvania, The Hotel.....150
 Piccadilly Hotel155
 Pilot Radio & Tube Corp..... 4
 Pohl, Arthur M.....157
 Polymet Mfg. Corp.....125
 Potter Co., The.....123

R

Radio Amateur Call Book.....151
 Radio Institute of America..... 27
 Radio Parts Co.....122
 Radio Service Lab., Inc.....142-153
 Radio Training Association of
 AmericaSecond Cover
 Readrite Meter Works.....129
 Roberts Radio Service.....146
 Royal-Eastern Electrical Supply
 Co.159

S

Samson Electric Co..... 21
 Sangamo Electric Co..... 35
 Scott Transformer Co.....7
 Shortwave & Television Lab., Inc.....136
 Shure Brothers Co.....121
 Silver-Marshall, Inc.120
 Supreme Instruments Corp..... 15

T

Teleplex Co.153
 Thordarson Electric Mfg. Co.....127
 Townsend Laboratories155
 Triad Mfg. Co., Inc..... 9

W

Wardman Park Hotel.....148
 Wedel Company122
 Western Radio Mfg. Co.....138-147
 Weston Electrical Instrument
 Corp.124
 Wholesale Radio Service Co.....151
 Wright-DeCoster, Inc.132

X

X. L. Radio Laboratories.....143

Y

Yaxley Mfg. Co.....122

SEND for New 1930

Radio and Electrical Wholesale Trade Catalog

→ IT IS FREE ←

Royal-Eastern's New 1930 General Wholesale Trade Catalog has been compiled to place before you a most comprehensive line of high-grade merchandise, at lowest wholesale prices.

Every worth-while radio, electrical and sporting goods item is featured at lowest wholesale prices. Being the largest radio and electrical mail order house in the East, we can serve you best. We buy no seconds. We have no job lots. Only fresh and clean products in original factory cartons.

Same day shipping service—and, Royal-Eastern never substitutes.

With our large warehouses and a background of thirty-two years of service to the trade, we are in a position to render the same service to you as has been our custom in the past.

Official authorized headquarters for New Hammarlund HiQ30 and Silver-Marshall.

Best Credit Rating!

OUR BANKING AFFILIATIONS AND DEPOSITORIES

The National City Bank of New York, N. Y.
Irving Trust Co., New York, N. Y.
Brooklyn National Bank, Brooklyn, N. Y.
Bank of Manhattan, Long Island City, N. Y.
Huguenot Trust Co., New Rochelle, N. Y.

*32 Years
Service to
the Trade*

**Send for Catalog Today!
IT'S FREE!**

*32 Years
Service to
the Trade*

Royal-Eastern Electrical Supply Company

16-18 West 22nd Street

Brooklyn, N. Y.

Branch Warehouses:

Long Island City, N. Y.

New York, N. Y.

New Rochelle, N. Y.

Tell 'Em You Saw It in the Citizens Radio Call Book Magazine and Scientific Digest

Everything in RADIO! at *Lowest* WHOLESALE PRICES

Get this ... CATALOG

This big book of 148-pages—rich from cover to cover with radio bargains—is yours for the asking. It contains all the latest radio devices and improvements—sets, accessories, parts and kits—profusely illustrated. No radio need is overlooked. Everything in this big book is available at wholesale prices, and many items are spotlighted as Specials at truly astounding reductions. To be without this book is to miss your greatest buying opportunity in radio. Every page points the way to money-saving. Never before have such startling values been offered—made possible by our tremendous buying power and low cost of operation. Quick deliveries and expert cooperation assured to all our clients. A trial order will make you a regular customer, just as it has thousands of our pleased customers.

Clip the Catalog Coupon, and mail it today!



New SCREEN-GRID Models

Marvelous offerings in new, Humless, Screen Grid A. C. all-electric and battery operated sets; a wide range of beautiful consoles, from the small table model types to the most ornate and artistic or radio furniture; dynamic speakers of tremendous volume and richest tone; accessories, parts and kits in wide variety—in fact, everything that is standard, as well as everything that is new, in Radio. Get this book today!

Price-saving COUPON

Chicago Salvage Stock Store
Dept. 131
509 So. State St., Chicago, Ill.
Kindly send me (free of charge and postpaid)
your new 148-page Book of Radio Bargains.

Name.....
Address.....
City..... State.....

CHICAGO SALVAGE STOCK STORE
World's Largest Radio Store
509 So. State St. Dept. 131 Chicago, Ill.

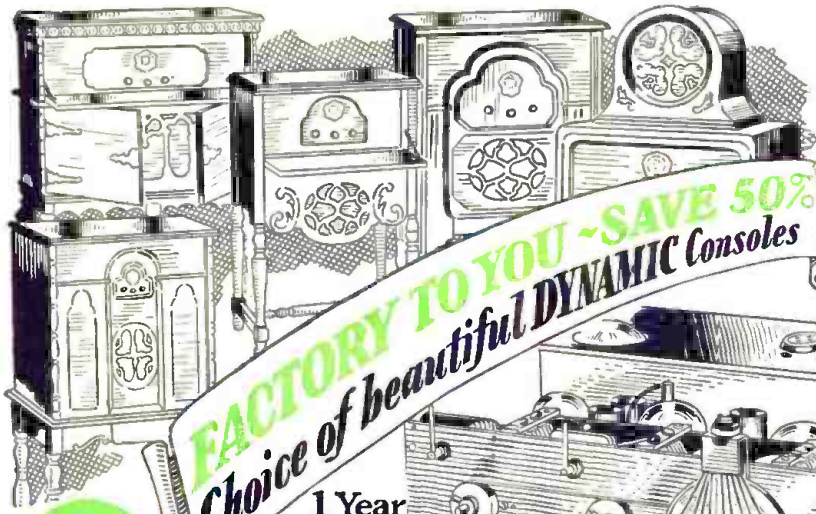

FACTORY TO YOU - SAVE 50%
Choice of beautiful DYNAMIC Consoles

1 Year Guarantee

TRY IT 30 DAYS FREE
BEFORE YOU BUY

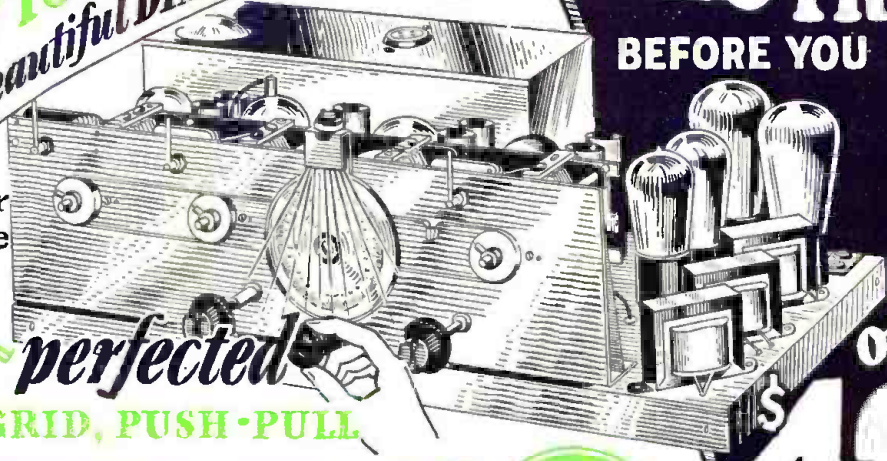

9 tube-perfected
SCREEN GRID, PUSH-PULL

MIRACO
 TRADE MARK REGISTERED

\$49⁸⁸ ONLY
COMPLETELY ASSEMBLED

CATHEDRAL TONED, SUPER SELECTIVE, POWERFUL DISTANCE GETTER

Compare with costliest sets before you buy!

You needn't send us a cent! America's big, old, reliable Radio Factory springs its 10th Anniversary Surprise in high-grade full-year guaranteed sets at history's lowest prices! With its latest perfected Screen-Grid, push-pull, super-powered and hum-free AC electric Miraco's—you are guaranteed satisfaction, values and savings unsurpassed.

At our risk compare a Miraco with highest priced radios, for 30 days in your home. Surprise and entertain your friends—get their opinions. Unless 100% delighted, don't buy! Your decision is final—no argument!

Only marvelously fine radios, of latest perfected type, at rock-bottom prices, can back up such a guarantee. Send postal or coupon for *Amazing Special Factory Offer!*

Don't Confuse with Cheap Radios
 With Miraco's rich, clear cathedral tone, quiet operation, razor-sharp separation of nearby stations, tremendous "kick" on

distant stations and latest improvements—you'll be the envy of many who pay 2 or 3 times as much!

Send for proof that delighted thousands of Miraco users cut through locals, get coast to coast, with tone and power of costly sets. Miraco's are custom-built of finest parts—product of 10 years' successful experience. Approved by Radio's highest authorities.

Deal Direct with Big Factory
 Miraco outfits reach you splendidly packed, rigidly tested with everything in place ready to plug in! No assembling! Entertain yourself 30 days—then decide. Liberal year's guarantee on each set. Play safe, save lots of money, insure satisfaction—deal direct with Radio's old, reliable builders of fine sets—10th successful year. **SEND POSTAL OR COUPON NOW!**

MIDWEST RADIO CORPORATION
 531-DN Miraco Building, Cincinnati, Ohio

Pioneer Builders of Sets — 10th Successful Year

I am greatly pleased with my AC-9 Miraco. Am getting stations everywhere. It sure out-performs any radios I ever heard that sell for twice the price. Neighbors and friends say it is the best they ever heard. E. W. Delbridge, Decatur, Ill.

User Agents Wanted!
Exclusive Territory

DEMONSTRATOR SENT GET OUR PROPOSITION

Excels \$425 Outfit
 My 30 days trial on my Miraco AC-9 is up and if you would offer me \$200 extra for it back, I would tell you nothing doing. We had some very expensive sets in our home, one a \$125 9-tube AC set. Thanks to you I have a set that gets any and all stations. I have got stations in 45 states, also Cuba and Canada. It is beyond words to tell you what we think of our wonderful bargain. I will always praise Miraco's to everyone—J. W. LAUBACK, Barborton, Ohio.

Coupon brings proof like this from people in YOUR locality, too.

SPECIAL ELECTRIC AC-7
\$39.85

BATTERY SET \$29.90

THIS COUPON IS NOT AN ORDER

Get our Send No Money 10th Anniversary Offer
Dealers Write! - mail coupon right Now!



BEAUTIFULLY ILLUSTRATED LITERATURE

AMAZING SPECIAL FACTORY OFFER, TESTIMONY OF NEARBY USERS—

Free!

All the proof you want—of our honesty, fairness, size, financial integrity, radio experience and the performance of our sets—including Amazing Factory Offer—sent without obligation!

MIDWEST RADIO CORP.
 531-DN Miraco Bldg.,
 Cincinnati, Ohio.

WITHOUT OBLIGATION, send latest literature, AMAZING SPECIAL FREE TRIAL FACTORY OFFER, testimony of nearby users, etc.

User Agent Dealer Check here if interested in an EXCLUSIVE TERRITORY PROPOSITION

NAME ADDRESS



LOCAL
STATIC!
—end it NOW
with

MUTER DEPENDABLE INTERFERENCE FILTERS

CLEAR-TONED, perfect music coming from your speaker. Or a program to which you are listening intently for every word. Then, suddenly—crackle—sizzle—roar! The program distorted, cut up, ruined.

How many times has this happened to you? Probably only a nearby motor or electrical appliance, acting as a broadcasting station of its own, setting up local disturbance. But the end, just the same, of radio enjoyment.

End this nuisance of man-made static once and for all with the MUTER DEPENDABLE INTERFERENCE FILTER.

Made in two types

1. **The Junior:** For direct connection to radio set. Capacity type, with large factor of safety for use on 110 volt A. C. Priced at \$5.00.
2. **The Senior:** For use in connection with electrical or mechanical devices causing local disturbances. Capacity inductance—rated for use on 110 volt A. C., on devices not exceeding 5 amp. current draw. The Senior may also be used in the same manner as the Junior, in direct connection with the radio set, offering an additional inductance to eliminate disturbances. Priced at \$7.50.

If your dealer cannot supply you, send direct

LESLIE F. MUTER COMPANY

8440 South Chicago Avenue, Chicago



The JUNIOR

Produced by the manufacturers of the Muter Ultra-Dynamic Speaker—the new speaker of glorious tone. Replace that old magnetic speaker with a MUTER.

