

Stromberg-Carlson

**RADIO RECEIVER
SERVICE MANUAL**

and

**INSTALLATION AND
MAINTENANCE INSTRUCTIONS**

ISSUED BY STROMBERG-CARLSON (AUSTRALASIA)
LTD. IN THE INTERESTS OF STROMBERG-CARLSON
AUTHORISED DISTRIBUTORS AND DEALERS

Stromberg-Carlson

General Service Bulletin

FOREWORD



THESE instructions apply generally to all Stromberg-Carlson Radio Receivers, except where otherwise stated. For more detailed service instructions covering any particular Model, reference should be made to the individual service bulletin issued for each Model. It is our endeavour to furnish our Distributors and Dealers with the fullest possible information covering our Receivers, so as to enable them intelligently to effect service repairs at a minimum cost in time and material.

We therefore ask that you carefully file this general service bulletin with its special cover, and bind in with it the individual service bulletins we will send you from time to time.

SERVICE TO CUSTOMERS.

Distributors and Dealers will have long since discovered that prompt and efficient service to existing customers is by far the best way of promoting new sales, therefore, let your motto be "Above all—service."

The Stromberg-Carlson Warranty issued with each Receiver protects the interests of customers, Dealers and ourselves, but it is essential that all of the conditions in regard to both registration and service be faithfully carried out. It is our settled policy to sell our Receivers only through "Authorised Stromberg-Carlson Dealers," as this is the best means of ensuring proper service to the purchaser and, at the same time, assisting the Dealer to build up a lasting business with maximum goodwill. Our Warranty only holds good provided the Receiver is purchased through an Authorised Stromberg-Carlson Dealer.

STROMBERG - CARLSON

GENERAL SERVICE BULLETIN (*Continued*)

INSTALLATION.

Every care should be taken properly to instal Radio Receivers as many complaints are traceable to faulty installation.

Aerial, Out-Door: Out-Door Aerials are seldom required in Metropolitan areas, except for interstate reception with the smaller Receivers. The aerial should be of the single wire type from 40 to 80 feet long, measuring from the extreme end of the wire along to the point of connection of the lead-in wire and then including the length of lead-in wire itself to the aerial terminal of the Receiver. The actual length, of course, also depends on the space available and also on the distance the Receiver is located from the nearest broadcasting station; if this distance is short, then it may be found necessary to restrict the length of the aerial to 40 feet, or perhaps shorter, which is best ascertained by the actual tests. If the distance between the two points of erection of the aerial is considerably more than the length required, then the aerial can best be shortened by cutting the aerial wire at the point required to give the correct length and inserting a small egg type porcelain insulator. The aerial wire should be preferably stranded wire of not less than 7/22 S.W.G., or its equivalent in mechanical strength in a solid wire. Care should be taken to avoid erecting aerials above unprotected electric light wires and, if this cannot be avoided, proper precautions should be adopted in accordance with the "Fire Underwriters" rules. Advice on this point is always available from the local Electric Supply Company. The lead-in wire must be first connected to a standard Stromberg-Carlson Lightning Arrester (approved by Fire Underwriters). Entry to the building must be by means of a porcelain or other approved insulating tube. The Receiver should be located as near as possible to the point of entry.

Aerial, In-Door: This should consist preferably of rubber covered flexible copper wire neatly run round the picture rail and thence direct to the aerial terminal of the Receiver (no Lightning Arrester being required). Its length should be from 15 to 40 feet, according to the type of Receiver and the proximity to a broadcasting station

STROMBERG - CARLSON

GENERAL SERVICE BULLETIN (*Continued*)

likely to cause interference. Generally about 20 to 25 feet gives good average results.

Earth: A good and a short earth is very desirable for best and quiet reception. The earth wire should be 7/22 S.W.G. or equivalent copper wire, neatly secured by staples to the skirting or wall and run by the most direct route, avoiding as much as possible too many right angle turns, to the nearest water pipe. The water pipe should be thoroughly cleaned and the earth wire connected to it by means of a special earth clip. An important point to remember is that a long earth wire acts precisely the same as a long aerial so far as selectivity is concerned, so that the importance of a short earth wire will be seen, particularly when Receivers are located near broadcasting stations.

RECEIVER.

It is always desirable for the Dealer to test the Receiver and accessories he proposes to use before delivery to the customer, as nothing creates a worse impression with a new customer than to connect up the Receiver and find that it will not work. Always see, therefore, that the Receiver and accessories are tested at your shop, where you have proper facilities. The Receiver should be unpacked and placed in position and connected up in the following order:—

Electric Models:

A. Check the line voltage with an A.C. Voltmeter with a single reading, preferably 0-300 Volts, and see that the voltage is within the limits provided for in the Receiver. The Receiver voltage can be varied within limits by shifting the power flex to the required tapping beneath the Chassis. (See service instructions for the particular model concerned.)

B. Connect aerial and earth wires to Receiver.

C. Place correct Valves in their respective sockets, in accordance with the instructions accompanying the Receiver.

D. See that Speaker is correctly connected.

E. Plug into electric light or power socket and then switch on.

F. Tune in in accordance with instructions for the particular Receiver.

STROMBERG - CARLSON

GENERAL SERVICE BULLETIN (*Continued*)

Battery Models:

- A. Connect aerial and earth wires to Receiver.
- B. Connect speaker.
- C. Connect the "A," "B," and "C" Batteries carefully, as shown on the Instruction Card for the particular Receiver. Use only good, heavy duty "B" Batteries. Be sure to see that the "C" Battery is properly connected, and is the right value, particularly for the last audio stage. Remember that if the "C" Battery is too low the "B" Battery current consumption will be high. In order to guard against burning out the valves by connecting the "B" Battery to the "A" Battery leads, a separate two-way cable is provided for the "A" Battery in the larger Receivers.
- D. Place test leads of your D.C. Voltmeter in the Filament holes of one of the Valve Sockets, and if this registers 4 Volts it indicates the "A" Battery is connected to the correct leads and the Valves may now be inserted in the sockets.
- E. The Receiver may now be switched on and operated in accordance with the instructions accompanying it.

LOUD SPEAKERS.

There are two types of loud Speakers in general use, viz.: Electro-Dynamic and Magnetic. The following points should be observed in connection with both installation and maintenance.

Dynamic, Rectifier Type.

This type is furnished with the step down Power Transformer which connects to the mains. The low voltage A.C. current is rectified by means of a metal type rectifier and a heavy current at low voltage is thus furnished to the speaker field coil. The

STROMBERG - CARLSON

GENERAL SERVICE BULLETIN (*Continued*)

moving coil of the speaker is connected through an input Transformer (usually mounted on the speaker frame or adjacent to it) to the speaker Jacks of the Receiver. This input Transformer is a step-down type with a ratio, varying with different makes, from 17 to 1 up to 25 to 1, with the high side connected to the speaker Jacks of the Receiver. If by any means the Transformer is removed, therefore, see that it is re-connected in the right way.

Dynamic D.C. Voltage Field Coil Type.

This type is standard on our Receivers. It has a field coil with a resistance of from 7,200 to 7,500 ohms. The maximum D.C. Voltage to be applied is 300 volts, which gives a drain of 40 milliamperes through the field coil. This D.C. supply is obtained by connecting the field coil through a standard flex, one side to one of the filament terminals of the rectifier tube, and the other side to chassis (earth).

NOTE: All of our 1931 Electric Receivers, except Model 22, are designed to operate with this type. If it is desired to use a Dynamic Speaker with Model 22 or similar models, the rectifier type Dynamic should be used.

Magnetic Speaker.

Where Magnetic Speakers are connected to Receivers having no output Transformer or output filter, it is essential that they be connected with the right polarity, that is, positive terminal of Speaker to positive jack of Receiver. If markings are indistinct, try both ways, and the correct way will easily be recognised by the fuller tone of the Speaker.

You should always explain to your customers not to overload unnecessarily any Speaker by operating it too loudly.

PHONOGRAPH COMBINATIONS.

When installing Radio Phonograph Combination Models, the following points should be observed:—

A. Check up connections between electric motor and manual or automatic "On-Off" Switch controlling it to see that it is properly

STROMBERG - CARLSON

GENERAL SERVICE BULLETIN (*Continued*)

linked up with the power circuit, usually by means of a special flex and porcelain connector provided on the back of the chassis of the radio receiver. If in doubt, check up with your A.C. Voltmeter. Be careful not to confuse it with the special lead coming out from the chassis which furnishes 250/300 volts direct current for the field of the Dynamic Speaker.

B. Check over leads from Pick-up and follow them through to the correct pick-up jacks on the Radio Receiver.

C. See that turn-table fits snugly on the centre spindle and that pick-up arm swings freely. Loud tone needles should be used for low impedance flexible armature Type 3-A Pick-up, and soft tone needles for high impedance Type 2-B Pick-up.

D. Check up all mounting screws, such as those holding the Receiver in position, Speaker unit, fixing bolts, and generally check up to make sure there are no loose parts in the whole combination likely to cause a rattle during operation.

E. Study the operating instructions and properly instruct the customer in all the small details of operation, for close attention to this will surely save you a number of service visits.

MAINTENANCE.

General.

A radio receiver, like a fine motor car, requires a small amount of maintenance from time to time. In order to handle this maintenance to the customer's satisfaction and the dealer's profit, the dealer must have on hand certain measuring instruments, tools, etc., for checking the operation of the radio receivers. A moderate stock of replacement parts should also be carried.

THE EQUIPMENT FOR CHECKING INSTALLATIONS AND THE STOCK OF REPLACEMENT PARTS WILL SAVE THE CUSTOMER TIME AND ANNOYANCE IF HIS RADIO RECEIVER NEEDS ATTENTION, AND WILL SECURE FOR THE DEALER THE CUSTOMER'S GOODWILL, PRICELESS ADVERTISING AND REPEAT BUSINESS.

STROMBERG - CARLSON

GENERAL SERVICE BULLETIN (Continued)

Instruments and Equipment.

In addition to the usual tools, such as pliers, wire cutters, screw-drivers, etc., the Dealer's maintenance man should be equipped with spare standard valves (which should be replaced immediately they fall below standard), and preferably with two high grade Jewell Voltmeters, one suitable for measuring alternating current line voltages, whilst the other should be of the direct current type with an internal resistance of from 300 to 1,000 ohms per volt, suitable for measuring D.C. voltages and preferably with low and high scale readings. In preference to the above two instruments, we would, however, strongly recommend the more costly but more satisfactory Jewell Pattern 199 A.C.-D.C. Analyser, which enables the maintenance man to diagnose rapidly a fault in a radio Receiver, stage by stage. Full details of these and other Jewell measuring instruments may be had on application.

INSPECTION AND TESTING.

General.

The inspection and testing of an installation of a radio receiver should be done systematically and an established procedure followed. Such an orderly routine makes an excellent impression on the customer and gives him confidence in the man doing the work. While each maintenance man generally works out his own procedure, suggestions are given in this section as a basis.

The maintenance man should be neat in his work as well as methodical. Some material, such as canvas, should be part of his equipment, so that he can cover up rugs, floors, or tables when he sets equipment on them. He should also be prepared to go over the cabinets, after the job is completed, to remove finger marks, dust, etc.

Valves.

EXPERIENCE SHOWS THAT A GREAT MAJORITY OF COMPLAINTS OF FAULTY OPERATION OF RADIO RECEIVERS ARISES FROM DEFECTIVE VALVES. THEREFORE, THE DEALER SHOULD BE DEFINITELY CERTAIN THAT THE

STROMBERG - CARLSON

GENERAL SERVICE BULLETIN (*Continued*)

VALVES PLACED IN THE RECEIVER AT THE TIME OF INSTALLATION ARE CAPABLE OF PROPER OPERATION. ALSO THE MAINTENANCE MAN SHOULD CARRY VALVES WITH HIM THAT HAVE BEEN CHECKED FOR OPERATION, AND HE SHOULD BE SURE THAT THE VALVES IN ANY INSTALLATION INSPECTED ARE WORKING PROPERLY, EVEN THOUGH THEY WERE NOT THE CAUSE OF COMPLAINT.

Aerial and Earth.

The aerial and earth installation is very often the cause of poor operation, and should be checked every time a Receiver is inspected, particular care being taken that where selective and sensitive aerial jacks are provided, that the aerial is connected in the jack most suitable for the particular local conditions. In the case of outside aerial, see that it is not making contact with a metal roof, pipe, etc., and so short circuiting to earth.

Line Voltage.

Always measure the line voltage on electric sets both at initial installation and at each inspection. If the line voltage is more than 5% high, repeat checks should be made at different times of the day, and if the voltage remains consistently high, the internal voltage tap on the power transformer should be altered to maximum, but in the event of it already being on maximum, arrangements should be made to instal a Line Voltage Regulator. In general, all of our Power Transformers on electric sets have three tappings, viz.: 240, 250, and 265. For localities where the correct voltage is 240, receivers are issued using the 250 tap. Where the line voltage standard is 250, receivers are issued on the 265 tap. Where the standard voltage is 230, receivers should be connected on the 240 tap, and will operate satisfactorily unless the actual voltage registers below 225, in which case our special Power Transformer should be used.

ANALYSIS OF FAULTS.

We outline below several classes of unsatisfactory operation and their

STROMBERG - CARLSON

GENERAL SERVICE BULLETIN (*Continued*)

causes. Whilst the causes shown will not cover all cases, we believe they will take care of almost any contingency which may arise in connection with the maintenance of Radio Receivers.

No Signal.

Speaker cord not plugged in jacks, or plugged in without making proper connection. Defective or poorly adjusted pick-up switch. Aerial disconnected or earthed. Defective valves. Line voltage discrepancies. Shorting or bad contacts in condenser gang, or midget condenser. Screen grid clips making poor contact. Damaged valve sockets. Dry or broken solder joints.

Weak Signal.

Poor aerial. Line voltage too low, or in battery sets, A., B., or C voltages too low. Defective valves. Damaged Speaker coils. Damaged radio or audio chokes or filters. Poorly adjusted pick-up switch. Screen grid clip broken or open circuit. Damaged valve socket. Circuit discrepancy or dry solder joints.

Broad Tuning.

Defective valves. Aerial connected to sensitive instead of selective jack. Aerial too long. Earth too long.

Fading.

Natural (atmospheric) causes. Defective valves. Broadcast station trouble. Aerial contacting to earth. Bad power point connection, or in the case of battery sets, dirty battery terminals. Extreme line voltage fluctuation. Nearby oscillating Receivers. Local electrical interference.

Poor Audio Quality.

This may be caused by Speaker, Receiver, or Broadcast Station.

1 (a). SPEAKER (Magnetic Type). Armature touching pole pieces. Cone pin bent, or cone injured.

1 (b). SPEAKER (Dynamic Type). Off centre. Moving coil earthed. Field coil faulty.

STROMBERG - CARLSON

GENERAL SERVICE BULLETIN (*Continued*)

2. RECEIVER. Defective valves. Defective audio transformer. Open or short circuited bias resistance. Improper filament B or C voltages.

3. BROADCAST STATION. Bad modulation. Fading distortion.

Hum.

Faulty valves. Open or unbalanced filament centre tap. Coupling from lighting circuit or electrical apparatus. Broadcast station hum. Telephone line hum (relay programme).

Noise.

Local interference. Atmospheric conditions. Defective electric light house wiring or accessories. Faulty valve. Loose connections or dry joints in Receiver. Loose aerial and earth connections. Short circuit contacts in gang or midjet condensers. Intermittent earthing of speaker coil.

Oscillation.

Faulty valves. Poor earth. Loose shield over coil or valve. Faulty by-pass condensers. Poor earth contact on rotor plates. Wrong plate or screen voltages.

Special Cases of Faulty Operation.

Receiver too close to powerful broadcast station. Receiver located in a position shielded by natural obstructions.

CONCLUSION.

The maintenance man with years of experience in radio servicing knows only too well special locality conditions exist in Australia. For instance, a Receiver in one locality will receive some stations perfectly, but other stations weak and distorted. No adjustments or alterations to the Receiver will cure such troubles. These special conditions exist in many parts throughout Australia, and that is one reason why relay stations are being erected. All such problems as these should be explained to the customer in simple language, so as to remove any doubts he may have that the trouble is due to faulty Receiver construction.

AUSTRALASIAN BROADCASTING STATIONS

A complete list of the broadcasting stations in Australia and New Zealand. The call signs, wave lengths, and programme schedules are given in full.

Call Sign	Metres	Name and Location.	Hours on the Air—Sydney Time.
7ZL	517	National Broadcasting Station, Hobart.	11.30 a.m. to 1.30—3 to 4.30—6.15 to 10 p.m.
3AR	484	National Broadcasting Station, Melbourne.	8.15 a.m. to 11—Noon to 12.30—2 to 5.45—6.15 to 10.30 p.m.
4YA	461.5	New Zealand Broadcasting Co., Dunedin.	1.30 p.m. to 3—3.30 to 8.30 p.m.
2FC	451	National Broadcasting Station, Sydney.	7 a.m. to 8.15—10.30 to 12.30—1 to 2.27—2.30 to 4.30—5.45 to 7.58—8 to 11.30.
6WF	435	National Broadcasting Station, Perth.	9.30 a.m. to 10.30—12 to 1.15—2.30 to 4.15—5.30 to 7—7.45 to 9.50—10 to 1 a.m.
2YA	416.7	New Zealand Broadcasting Co., Wellington.	1.30 p.m. to 3—3.30 to 8.30 p.m.
5CL	411	National Broadcasting Station, Adelaide.	8 a.m. to 9—11.30 to 2.30—3.30 to 5—6.30 to 8.10—8.16 to 11.30 p.m.
4QG	395	National Broadcasting Station, Brisbane.	7.30 a.m. to 8.30—11 to 2—3 to 4.30—6 to 7.55—8 to 11 p.m.
3LO	375	National Broadcasting Station, Melbourne.	7 a.m. to 8.15—10.30 to 12.30—1 to 3—3 to 4.30—5.45 to 11.30 p.m.
2BL	351	National Broadcasting Station, Sydney.	8.15 a.m. to 11—12 to 2—2.30 to 5.45—6.15 to 7.58—8 to 11.30 p.m.
7HO	337	Findlays Pty. Ltd., 80 Elizabeth Street, Hobart.	8 a.m. to 9—12.30 to 2—6.30 to 10.30 p.m.
1YA	333.3	New Zealand Broadcasting Co., Auckland.	1.30 p.m. to 3—3.30 to 9.30 p.m.
4RK	322	National Broadcasting Relay Station, Rockhampton.	Not yet in operation.
3UZ	322	Oliver J. Nilsen & Co., 45 Bourke St., Melbourne.	9 a.m. to 12—5.30 to 10.15 p.m.
2GB	316	Theosophical Broadcasting Station Ltd., Sydney.	10 a.m. to 12—2 to 3.10—5.15 to 7.6—8 to 11.30 p.m.
5DN	313	5DN Pty. Ltd., 2 Montpelier St., Parkside, Adelaide.	Not operating to schedule.
3YA	306.1	New Zealand Broadcasting Co., Christchurch.	2.30 p.m. to 3—3.30 to 6.30—6.30 to 8.30 p.m.
2WG	303	Friendly Farmer Syndicate, Wagga	Not yet in operation.
6ML	297	Musgroves Ltd., Lyric House, Murray St., Perth	1 p.m. to 2—2.30 to 4—5 to 6—7.45 to 12 p.m.
4GR	294	Gold Radio Service, Ruthven St., Toowoomba	Noon to 1 p.m.—Evening sessions irregular.
2UE	293	Electrical Utilities Supply Co., Radio House, Sydney	7.15 a.m. to 8.30—9.30 to 11.30—6 to 10.15 p.m.

AUSTRALASIAN BROADCASTING STATIONS (Continued)

Call Sign	Metres	Name and Location.	Hours on the Air—Sydney Time.
2CA	285	A. J. Ryan, Canberra, F.C.T.	Not yet in operation.
2KY	280	Trades Hall, Goulburn Street, Sydney	10 a.m. to noon—6 to 10 p.m.
7LA	275	Wills & Co. Pty. Ltd., 7 Quadrant, Launceston.	Not yet in operation.
2UW	267	Radio Broadcasting Ltd., Paling's Bldgs., Sydney.	10.30 a.m. to 2—5.15 to 6.40—7 to 10.30 p.m.
2MK	260	Mockler Bros., Howick St., Bathurst.	Not operating to schedule.
4CH	256	R. W. Gaskin, Charleville.	Not yet in operation.
3DB	255	3DB Broadcasting Station Pty. Ltd., Melbourne	7 a.m. to 8.30—11.0 to 1.45—2.15 to 11 p.m. Sat. & Sun Evngs. only.
4MK	252	Williams' Agencies Ltd., Mackay.	Not yet in operation.
5KA	250	Sport Radio Broadcasting Co. Ltd., Adelaide.	8 a.m. to 9—2.30 to 3.30—6.15 to 10.30 p.m.
2NC	241	National Broadcasting Relay Station, Newcastle.	Same as 2FC.
4TO	238	Amalgamated Wireless (Asia), Townsville.	Not yet in operation.
3WR	238	Wangaratta Broadcasting Co. Ltd., Wangaratta.	Not yet in operation.
3TR	234	Gippsland Broadcasting Service, Trafalgar Ltd., T'gar.	Not yet in operation.
4BC	233	J. B. Chandler & Co., 43 Adelaide St., Brisbane.	2.30 p.m. to 3.30—5.45 to 10.30 p.m.
3BA	231	Balliarat Broadcasters Pty. Ltd.	7 p.m. to 10 p.m.
5AD	229	Advertiser Newspapers Ltd., Adelaide.	10.30 a.m. to 12.30—3.30 to 5.30—6.30 to 10.30 p.m.
2AY	227	Charles Rice, Radio House, Albury.	Not yet in operation.
2XN	224	G. W. Exton, Lismore.	7 p.m. to 9 p.m.
3KZ	222	Industrial Printing and P'lishing Co., Carlton, N.3.	Testing.
4BK	217	Brisbane Broadcasting Co., Brisbane	Not yet in operation.
3GL	214	Geelong Broadcasters Pty. Ltd., Geelong.	Not yet in operation.
3HD	212	Airsales Broadcasting Co., Civic Building, Newcastle.	11 a.m. to 1—6 to 10 p.m.
3BO	207	Amalgamated Wireless (Asia), Bendigo.	Not yet in operation.
2MV	205.4	The Moss Vale Broadcasting Service Ltd., Moss Vale.	Not yet in operation.
2GN	201.34	Russell's Ltd., Dealers, Goulburn, N.S.W.	Not yet in operation.
2MO	200	M. J. Oliver, Gunnedah.	Not operating.

INSTALLATION

of the

ROAMER AUTOMOBILE RECEIVER

with

Instructions for the Elimination of Ignition Interference



(1) Before installing the Roamer Receiver in a car or motor boat, it is essential that the ignition system and general car wiring should be thoroughly overhauled and inspected for loose or poor contacts, leakages, etc. Defective wiring should be replaced.

(2) Generally speaking, it should not be necessary to shield any unit or any of the wiring in the engine compartment under the hood. Should, however, the ignition coil or high tension switch be mounted on the Driver's side of the engine bulkhead, it will be necessary to either shield these units, or in the case of the ignition coil remove it to the engine side of the bulkhead.

(3) The sources of interference may be classified under two headings:

- (a) Ignition interference due to high frequency surges in the spark plugs and associated wiring.
- (b) Low frequency interference generally traceable to the charging system, such as commutation ripple from the charging generator.

(4) The standard method of eliminating interference from the high frequency ignition system is to fit suppressors to each of the spark plugs and to the main H.T. lead from the distributor head. From tests conducted on both old and new spark plugs under compression equivalent to that encountered in the cylinder head, with the gap adjusted to .015 or .02 of an inch, no effect on the intensity of the spark can be observed with or without the standard suppressors.

(5) The standard method of eliminating interference from the low frequency charging system is to fit a 1 or 2 microfarad condenser between the main charging brush and the return brush on the generator.

(6) Should the interference still be noticeable after the foregoing standard equipment has been fitted, the following tests should be conducted in order to determine the source of the remaining interference. All tests being made with the engine hood down.

USEFUL INFORMATION

on

RESISTANCES

The colour code usually employed for fixed resistances is that of the Radio Manufacturers' Association (U.S.A.). This is known as the R.M.A. Standard Resistor Colour Code.

Under this code, each resistor is marked with three colours, definitely to identify it, each colour representing a figure. The body colour represents the first figure of the resistance value. One end is coloured to represent the second figure, while a dot of colour represents the number of ciphers (or noughts) following the first two figures.

The key to the R.M.A. colour code is as follows:—

Figure.	Colour.	Figure.	Colour.
0	Black	5	Green
1	Brown	6	Blue
2	Red	7	Violet
3	Orange	8	Grey
4	Yellow	9	White

The colour combinations for some of the more common values of fixed resistances are tabulated below. The table below gives the resistance value and its corresponding colour arrangement.

Resistance.	Body A	End B	Dot C
200 ohms	Red	Black	Brown
300 "	Orange	Black	Brown
500 "	Green	Black	Brown
1,000 "	Brown	Black	Red
1,500 "	Brown	Green	Red
2,000 "	Red	Black	Red
2,500 "	Red	Green	Red
3,000 "	Orange	Black	Red
3,500 "	Orange	Green	Red
4,000 "	Yellow	Black	Red
5,000 "	Green	Black	Red
6,000 "	Blue	Black	Red
8,000 "	Grey	Black	Red
9,000 "	White	Black	Red
10,000 "	Brown	Black	Orange
12,000 "	Brown	Red	Orange
15,000 "	Brown	Green	Orange
17,000 "	Brown	Violet	Orange
20,000 "	Red	Black	Orange
25,000 "	Red	Green	Orange
30,000 "	Orange	Black	Orange
40,000 "	Yellow	Black	Orange
50,000 "	Green	Black	Orange
75,000 "	Violet	Green	Orange
100,000 "	Brown	Black	Yellow
150,000 "	Brown	Green	Yellow
200,000 "	Red	Black	Yellow
250,000 "	Red	Green	Yellow
300,000 "	Orange	Black	Yellow
400,000 "	Yellow	Black	Yellow
500,000 "	Green	Black	Yellow
1 Megohm	Brown	Black	Green
1.5 "	Brown	Green	Green
2 Megohm	Red	Black	Green
2.5 "	Red	Green	Green
3 "	Orange	Black	Green
4 "	Yellow	Black	Green
5 "	Green	Black	Green

USEFUL INFORMATION—Continued.

This table gives some colour combinations with their corresponding resistance value.

Body.	Colour.		Resistance in Ohms.
	End.	Dot.	
Brown	Black	Red	1,000 ohms
Brown	Black	Orange	10,000 "
Brown	Green	Orange	15,000 "
Brown	Black	Yellow	100,000 "
Brown	Black	Green	1,000,000 "
Red	Black	Brown	200 "
Red	Black	Red	2,000 "
Red	Black	Orange	20,000 "
Red	Green	Orange	25,000 "
Red	Black	Yellow	200,000 "
Red	Green	Yellow	250,000 "
Red	Black	Green	2,000,000 "
Orange	Black	Brown	300 "
Orange	Black	Red	3,000 "
Orange	Black	Orange	30,000 "
Yellow	Black	Red	4,000 "
Green	Black	Brown	500 "
Green	Black	Red	5,000 "
Green	Black	Orange	50,000 "
Green	Black	Yellow	500,000 "
Grey	Black	Red	8,000 "

Should the exact resistance desired not be available, a combination of resistances at hand can usually be made to give the value sought. There are two ways in which resistances may be combined—(a) in series, (b) in parallel.

(a) Resistors in series have a total resistance equal to the sum of the individual resistances, thus:—

$$R = r_1 + r_2 + \text{etc.}$$

where R is total resistance and $r_1, r_2, \text{etc.}$, are the individual resistances.

(b) Resistors in parallel have a resultant value given by the formula:

$$R = \frac{1}{\frac{1}{r_1} + \frac{1}{r_2} + \text{etc.}}$$

For example, placing a 500 ohm and a 1000 ohm resistance in parallel gives:—

$$R = \frac{1}{\frac{1}{500} + \frac{1}{1,000}} = 333.3 \text{ ohms.}$$

Causes of "Cutting Out" or Sudden Changes in Volume

One of the most annoying faults in a modern A.C. receiver, encountered by service men, is the elusive "cutting-out" or intermittent fluctuation in the level of reproduction.

The fault is often elusive, since it appears and disappears at odd intervals without apparent cause. The switching on or off of an electric circuit in the vicinity of the receiver will often restore normal operation. Touching the grid cap of one of the valves acts in a similar manner and restores normal volume. In fact, any transient voltage induced into the receiver results in a "trigger-action" and temporarily restores normality.

For these reasons, a faulty chassis brought into a factory or test bench for observation will, as likely as not, fail to exhibit the symptoms of "cutting-out." The continual interference associated with a factory or test room appears to act on the source of the trouble and prevent its manifestation, thus rendering the task of the service man even more difficult.

A review of these faults is submitted herewith, in the hope that they will prove of assistance to service men who may encounter similar troubles on our receivers and on those of other makes. This summary is the result of observations taken over an extended, both in the laboratory and test rooms and in the field. We have been greatly assisted in compiling this report by the ready co-operation of our Distributors and Dealers.

Some of the main causes of "cutting-out" may, for convenience, be grouped as follows:—

- (1) Resistors
- (2) Capacitors
- (3) High-resistance contacts
- (4) Valves
- (5) Causes external to the chassis.

(1) RESISTORS.

The carbon type of resistor is particularly prone to internal changes in resistance, and in some cases, due to microscopic fractures in the material, to intermittent open circuit.

As these structural fractures are more or less microscopic, a slight surge or transient voltage will result in an arc, and temporarily bridge the fracture. The continual expansion and contraction of the resistor material, due in turn to the wide variations in temperature encountered in operation, undoubtedly cause or aggravate these structural fractures. A receiver may thus be in use for some time before this fault manifests itself in signal fluctuations.

The ordinary methods of testing carbon resistors for this fault are apt to be misleading. Substitution, although tedious, would seem to be one way of locating the faulty unit. A stage by stage check will often narrow the field of test to one particular section of the receiver.

The oscillator-mixed cathode resistor and the plate and screen resistors in the Intermediate Frequency and second detector should be examined.

(2) CAPACITORS.

Small Radio Frequency and by-pass capacitors are sometimes the cause of signal fluctuation. Both mica and paper capacitors offend in this direction. Of the two types, the paper capacitors (probably due to the difficulty of attaching permanent leads to the foil) are somewhat more prone to develop intermittent high resistance contacts or leaky shorts. Here again it is somewhat difficult to detect the offending unit. A small electrical surge or mechanical jar may be sufficient to temporarily overcome the high resistance contact and so restore normal operation.

Examine the cathode, plate and screen by-pass capacitors and the coupling capacitor between the detector and audio valve.

(3) HIGH-RESISTANCE CONTACTS.

In a radio chassis there are a number of points where the continuity of a circuit must, of necessity, rely upon the metallic pressure contact or spring contact. Valve sockets, grid clips, speaker sockets, pick-up jacks, volume controls and the contacts to the rotor sections of the gang capacitor are examples of such pressure contacts.

While a weak or loose contact will generally cause signal fluctuation, the fault need not necessarily be due to lack of tension. A thin film of oxide on one, or both of the points of contact will result in a high resistance, especially to the weak Radio Frequency currents. Here again we have a reason for the rather baffling fault of a sudden drop in volume, and the equally sudden restoration in volume. The latter condition occurs when the high resistance contact has been removed by an obvious mechanical jar or the less obvious electrical transient. The transient may result from the switching off or on of the receiver itself, or an electric light or power circuit in the vicinity of the receiver.

To cure this fault it is necessary to clean the surfaces of contact (preferably with fine emery paper) and, where necessary, increase the tension of the contacts.

Under the heading of High Resistance Contacts, we must also include loose, broken and unsoldered or dry joints.

While every effort is made in the process of manufacturing and assembly to avoid dry joints, a small percentage would appear to defy detection and pass all visual and electrical tests, only to manifest later, the delay in manifestation being due, no doubt, to the slow oxidization of the metal surfaces. The location and cure of these joints or loose contacts are somewhat more obvious.

(4) VALVES.

In analysing the sources of signal fluctuation in receivers, a number of cases have been observed where the fault was definitely traced to a particular valve. Unfortunately, valve checkers and analysers are of little value in locating this type of defect.

Irregular cathode emission, thermostatic valves, sporadic ionization of the gas content in the valve, are some of the probable causes.

Instances have also been found where the control grid wire made poor or intermittent contact with the grid cap.

Changing the valves, stage by stage, should indicate the defective unit.

(5) CAUSES EXTERNAL TO THE CHASSIS.

Under this heading we may list the aerial, the earth and the power connections.

Thoroughly inspect the aerial, making sure that it does not swing against any metallic or partly earthed object, and that the joints are well soldered and the lead-in well insulated. Also make sure that the lead-in is well gripped under the aerial terminal on the chassis.

The earth lead should also be inspected for continuity of circuit, and especially examine the contact to the water-pipe, or buried plate.

These contacts, in most instances, rely upon pressure only, and in the case of water pipes, the only reliable method is by means of an approved clamp with a screw biting into the surface of the pipe. This clamp should be attached to the last section of the pipe before it enters the ground.

Loose fittings in the electric light or power connections may result in signal fluctuation. Electric supply mains, in certain areas, are subject to voltage variations, these variations being reflected in a corresponding rise or fall in the signal level.

SUMMARY.

The elusive causes of "cutting-out" or sudden changes in signal level, cannot be reduced to any one common origin. The main cause, however, would appear to be due to intermittent high resistance contacts—whether in the internal construction of the component, such as a resistor or capacitor, or to one of the many points in a receiver where the continuity of a circuit relies upon the pressure-contact of two metallic surfaces.

It must be admitted that the location of this type of fault may prove a tedious task, but close observation will generally narrow the field of search to one section of the circuit, and, by the process of elimination, the fault may then be traced to its source.

STROMBERG - CARLSON (AUSTRALASIA) LIMITED

Influence of Atmospheric Conditions on Radio Reception

The influences controlling a radio wave between the Transmitting Station and the Receiver are rarely appreciated, and the operator of a Radio Receiver is seldom aware of the fact that the strength and quality of Radio Reception are governed by a number of external influences between these two points.

A brief study of some of these influences will assist us in obtaining a better understanding and appreciation of our Radio Receivers, and especially of some of the vagaries encountered in the reception of distant stations.

In the first place, it should be explained that the radio waves from the Broadcast Station consist of what are commonly called "Ground Waves" and "Sky Waves." Ground Waves, as the name implies, follow the earth's curvature, but, unfortunately, die out or are absorbed at a radius of about 100 miles from the station. These Ground Waves are responsible for the strong and steady signals within the service area of the station, being more or less unaffected by the various influences which affect the Sky Waves.

The Sky Waves are radiated through the atmosphere. Whilst it is these waves which make long-distance reception possible, they are most susceptible to external influences and consequently vary considerably.

The fact that radio reception (of broadcast signals) is much stronger at night than by day, is well known; the reason, however, is not so generally understood.

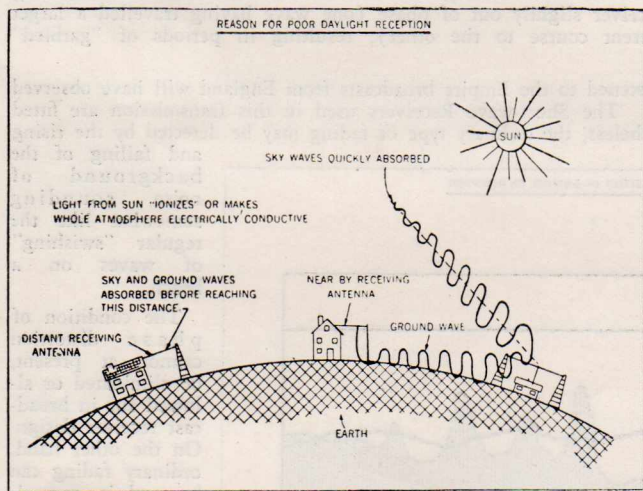

During the daylight hours, the sun is radiating and bombarding the atmosphere with electrons; this electronic stream "ionizes" the atmosphere, making it electrically conductive. It is this conductive atmosphere which quickly absorbs the Sky Waves and renders distant reception of over three to four hundred miles, by day, extremely rare. After sunset, the ionization of the lower strata of atmosphere quickly disappears, leaving

an upper strata of rarified atmosphere, which acts as a reflector or mirror for the Sky Waves. This reflecting layer is known as the "Heaviside" layer (after Oliver Heaviside, the English scientist, who first advanced this theory), and is located between 40 to 200 miles above the earth's surface.

If it were not for the existence of this reflecting surface of ionized gases, the reception of broadcast signals beyond a distance of about 200 to 400 miles would be impossible, since the Sky Waves travelling in a straight line would pass out of our atmosphere into space.

As it is, these Sky Waves, on striking this layer are reflected back (as light from a mirror) to the earth's surface. The under-surface or contour of the layer is continually changing in its height and angle of incidence, with respect to the earth's surface. Sometimes these changes are rapid; at other times slow, according to the weather and other atmospheric conditions which may prevail at the time. Apart from the daily effect of the sun's electrical bombardment upon the atmosphere, there is the seasonal effect,

reception being better in winter than in the summer months of the year. In addition, recent experiments have shown that the planets in their orbits, being electrically charged masses, effect this electronic stream from the sun.

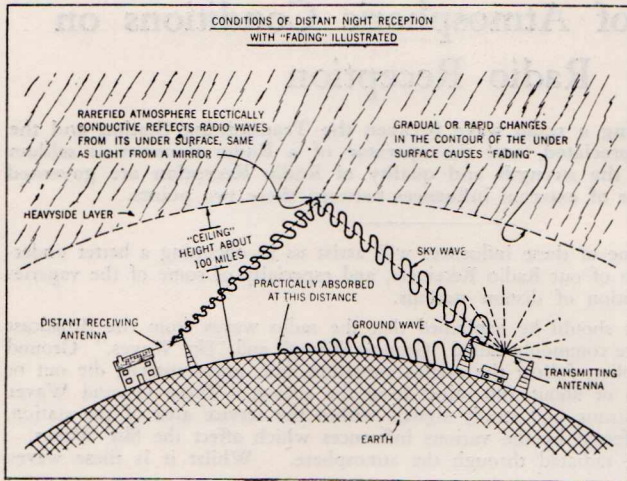

The eleven-year sun spot cycle also governs radio reception for the same reason — for instance, we are now in a period of this eleven-year cycle when distant receipt is at its best, and foreign stations are being received in Australia at abnormal strength.

This gradual or rapid change in the Heaviside layer naturally interferes with the steady reflection of the Sky

Waves, and results in the "fading" of signal strength, so noticeable over long distances.

There is another type of interference, due to the same phenomena, which generally, but not necessarily, accompanies "fading." This is the condition where the quality of reception varies, and is due to waves coming from two or more directions, and combining at the aerial of the Receiver slightly out of phase (one wave having travelled a larger distance or by a different course to the other), resulting in periods of "garbled" reproduction.

Those who have listened to the Empire broadcasts from England will have observed this periodic distortion. The Short-wave Receivers used in this transmission are fitted with A.V.C., but nevertheless, the ordinary type of fading may be detected by the rising

and falling of the background of noise, sounding somewhat like the regular "swishing" of waves on a beach.

The condition of phase distortion cannot, at present, be eliminated or allowed for in broadcast receiver design. On the other hand, ordinary fading can be, and is, controlled in Receivers fitted with an efficient Automatic Volume Control such as is incorporated in the higher-priced units of the Stromberg-Carlson line.

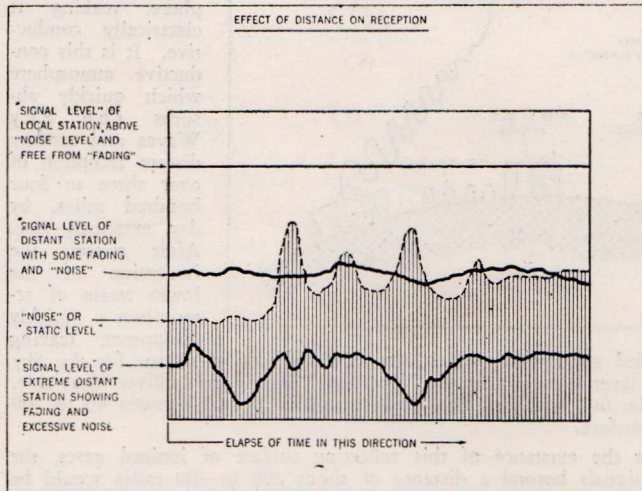

Whilst it is conceded that the best reception, free from interference and fading, is that obtained from the local stations, there is still a fascination in the "picking-up" of far distant stations, and this in itself is an added incentive to considering the purchase of a STROMBERG-CARLSON RECEIVER.

STROMBERG - CARLSON (AUSTRALASIA) LIMITED

Stromberg-Carlson

SERVICE MANUAL No. 22

Radio Receiver Model 22x.

ALL-ELECTRIC TWO VALVES AND RECTIFIER

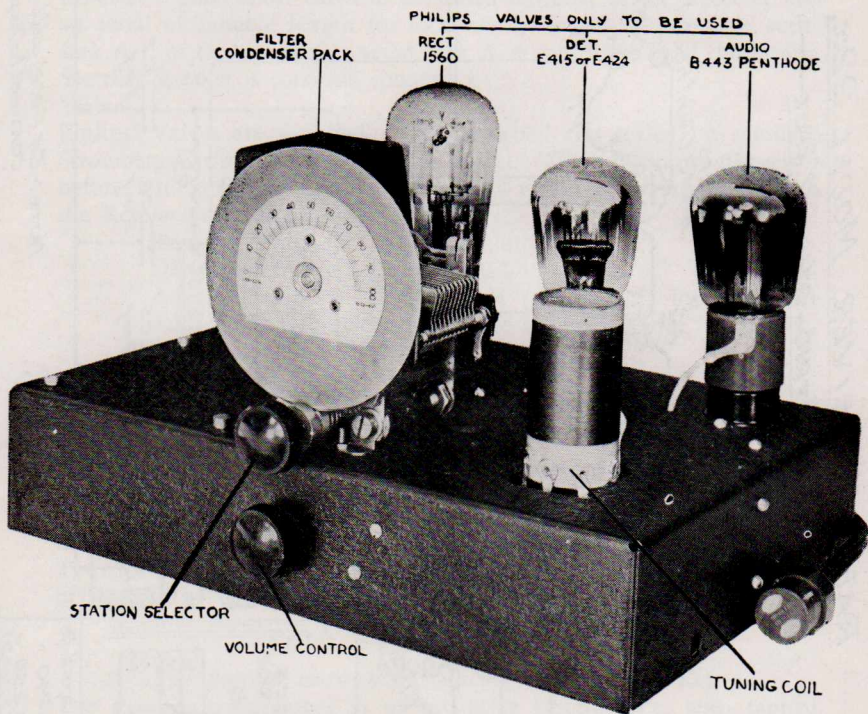

Chassis of 22x Model

This Service Bulletin is issued free of charge to all Authorised Stromberg-Carlson Distributors and Dealers. Applications for additional copies should be made direct to Stromberg-Carlson (Australasia) Ltd.

RADIO RECEIVER MODEL 223C

— ALL ELECTRIC - 2 VALVES & RECT. —

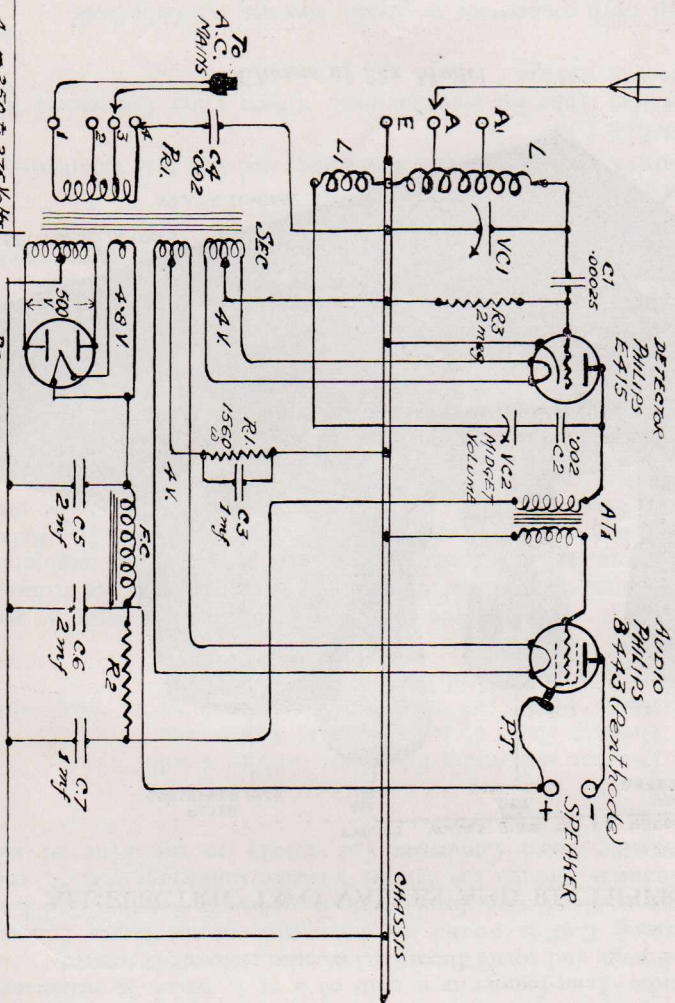

- 1 & 4 - 250 to 275 Kc/Ks
- 1 & 2 - 225 to 240 "
- 1 & 3 - 240 to 250 " (ISSUED)

NOTE: C_4 (0.002) will in some cases connect to Tap 1 not Tap 4.

DRAWING No 12
 DRAWN BY N 9
 Approved
 15-1-1931

STROMBERG-CARLSON (ASIA) LIMITED
 - SYDNEY - AUSTRALIA -

CHANGES

STROMBERG - CARLSON

SERVICE BULLETIN No. 22 (*Continued*)

Radio Receiver Model 22x.

ALL-ELECTRIC TWO VALVES AND RECTIFIER.

This Receiver is generally similar to Model 22, which it supersedes. It has been re-designed to simplify wiring and to incorporate several added refinements, such as the addition of the anti-hum Modulator Condenser and an improved Filter system.

General.

Instal in accordance with instructions in the general Service Bulletin, taking care to check up the A.C. Line Voltage. The Receiver is issued with the Power flex connected for use on 240 Volt circuit. If the locality has a different voltage supply, refer to circuit diagram and alter the taps accordingly.

Connect a good short earth to the earth terminal of the Receiver and an aerial of suitable length for local conditions to the sensitive aerial Jack A-1, or to the selective aerial Jack A, according to local conditions. See that Speaker is correctly connected.

Valves.

Philips' Valves are supplied, tested, matched and sealed, in standard Stromberg-Carlson cartons, for each model. When testing the Receiver before issue to the customer, the actual valves to be supplied with the Receiver should be used for the test.

Rectifier: Philips 1560 (Type 280).

Detector: Philips E.415 or E.424.

Audio: Philips B.443 Penthode (the flexible lead near the Audio socket connects to the side terminal of the Penthode).

Dial Lamp: 4 or 6 Volt type.

Operation.

This Receiver is of the simple regenerative type, the upper control knob selects the stations, whilst the lower control knob controls reaction and, at the same time, volume.

Speaker.

This Model is designed for Magnetic Speakers, but the Dynamic type may be used, provided they are of the A.C. Rectifier type, as the Power Transformer on the Model 22 is not designed to carry the extra load of the D.C. Field type Dynamic.

TECHNICAL DESCRIPTION.

(To be read in conjunction with Drawing No. 12)

The **Power Transformer** is of the layer wound type, with tapped primary to suit various line voltages from 225 up to 275. A special Condenser C.4 (.002 mf.) is connected from one side of the primary to earth to cut out A.C. hum modulation. Try plug in A.C. mains socket both ways for minimum modulation hum. Two centre tapped 4 volt windings supply the Filaments of the Detector and Audio Valve. A 4.8 volt winding furnishes current for the Rectifier Filaments with a 500 volt centre tapped winding for the Rectifier Plates.

The **Power Filter** consists of a single Filter Choke F.C., with a 2 mf. Condenser on the input side, and a similar capacity on the output.

STROMBERG - CARLSON

SERVICE BULLETIN No. 22 (*Continued*)

The Plate and extra Grid of the Penthode is supplied from the output end of the Filter Choke, but the Detector Plate is supplied at a lower voltage through Resistance R.2 (30,000 ohms). This resistance is by-passed with C.7, 1 mf. Condenser.

The **Bias Resistance**, R.1, 1560 ohms, by-passed with C.3, 1 mf. Condenser, is connected between the centre tap of the Audio Filament winding and chassis.

The **Audio Transformer** is a ratio of 6 to 1, which is satisfactory with one stage and where the input into the Detector is limited.

The **Tuning Coil** is wound on the outside of the larger Former, whilst the smaller Former fixed within it carries the Reaction Coil L.1, which connects through the Midget Variable Condenser V.C. 2, and the protective Fixed Condenser C.2 (.002) to the Plate of the Detector.

Voltages.

Detector and Audio Filaments: 3.75 to 4 volts.

Detector Plate: 65 to 75 volts at 4 to 6 mas.

Audio Plate: 165 to 175 volts from 8 to 12 mas. with 18 to 20 volts Grid Bias.

Faults.

These models are of simple and strong construction, with a low current consumption, so that the possible service troubles are reduced to a minimum, and this statement has been proved by the negligible number of service troubles reported on the previous Model 22. Refer to General Service Bulletin as to the general type of faults to be met with, and their cause.

The following are possible faults in this model:—

No Reaction.

Examine Midget Variable to see that plates are not shorted. Test reaction coil for open circuit.

No Voltage.

(a) Detector Plate. Examine joints on Resistance R.2.

(b) Audio Plate. Open circuit Filter Choke or open circuit Speaker.

High Plate Current.

Audio Valve. Check R.1 Bias Resistance, and C.3 Bias Condenser.

All Voltages Low.

Test Rectifier Tube for emission loss. Check Filter Condensers for breakdown or leakage.

Noise.

Check all earth connections to chassis, and test R.3 Grid Leak.

Replacement Parts.

When ordering replacement parts, you will ensure getting the right part if you quote, wherever possible, the indicating letter and number shown on the drawing for the particular part you require.

Stromberg-Carlson

STROMBERG-CARLSON
SERVICE BULLETIN, No. 35C.

Stromberg-Carlson Model 35c Superheterodyne Short Wave Selector

ALL ELECTRIC, TWO VALVES AND RECTIFIER.

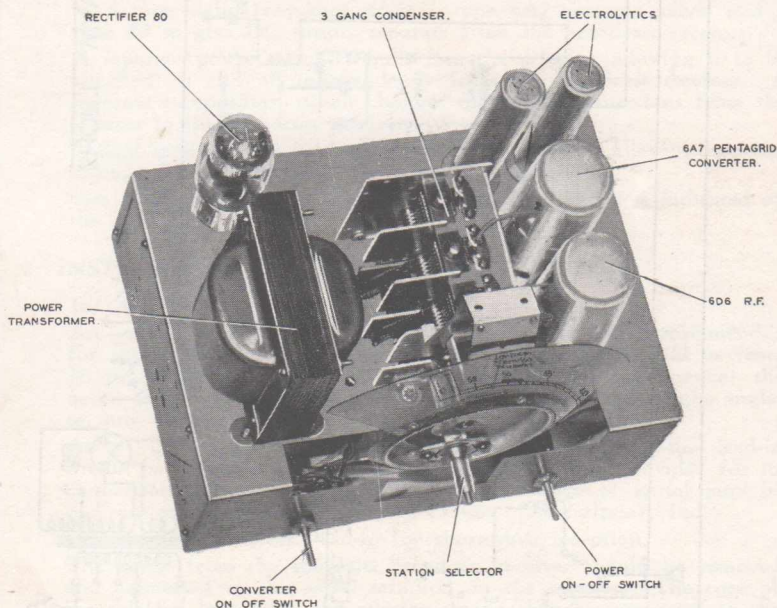

Chassis of Model 35C

This Service Bulletin is issued free of charge to all authorised Stromberg-Carlson Dealers. Applications for additional copies should be made direct to the nearest Distributor.

Stromberg-Carlson (Australasia) Ltd. reserves the right to make changes in design details at any time without incurring any obligations to install same on radio receivers previously sold.

Stromberg-Carlson Model 35c Superheterodyne Short Wave Selector

ALL ELECTRIC, TWO VALVES AND RECTIFIER.

1. GENERAL DESCRIPTION OF SELECTOR:

The Model 35C Selector is designed to be used in conjunction with a standard broadcast receiver to make available reception on the short-wave bands. The tuning range is from 19 to 53 metres. This range is covered by one set of coils, and includes the four important internationally assigned short-wave broadcast bands of 19, 25, 31, and 49 metres respectively.

The selector is a 3-valve superheterodyne type using a type 6D6 valve as a tune radio frequency stage, a type 6A7 detector valve, and a type 80 to give DC supply separate from the broadcast receiver.

A separate power switch is built into the selector, allowing it to be switched on and off independently from the broadcast receiver. A separate two-position switch changes the aerial connections from the selector to the broadcast receiver.

A dual ratio drive is used when tuning the selector, allowing accurate tuning of short-wave stations.

The location of the 19, 25, 31, and 49 metre bands is indicated on the dial of the selector.

2. INSTALLATION INSTRUCTIONS:

(a) Aerial.

An outdoor aerial is the most efficient, and is strongly recommended for short-wave reception. The length of this aerial should be from 30 to 50 feet. In noisy areas (due to electrical interference) the aerial should be erected as far as possible from, and at right angles to, any electric power or light mains.

As a further precaution against undesirable pick-up, the lead-in should be a special transposed type, terminals being provided for its connection on the selector. Details of this type of aerial may be had on application to Stromberg-Carlson (Australasia), Ltd.

Do not use a shielded lead-in for short-wave reception.

The aerial from the standard broadcast receiver should be removed and connected to the aerial terminal on the selector. The core of the shielded lead from the selector should then be connected to the aerial terminal of the standard receiver, and the outer shield connected to the earth terminal of the receiver.

(b) Earth.

The chassis should be connected to earth by means of an insulated wire attached to a water pipe by an approved clamp. It is preferable to connect the earth lead to the last section of the pipe where it enters the ground, thus avoiding the high resistance contacts at the joints. Should a water system not be available, an efficient earth may be obtained by driving a metal pipe or burying about four square feet of metal sheeting in moist earth; the connection to the metal should preferably be soldered.

SERVICE BULLETIN, No. 35C—(Continued)

(c) Trimmer Adjustments.

The trimmer capacitors on the coil assembly are adjusted and sealed at the factory at the time of calibration. These adjustments should on no account be touched or seals broken unless a specially calibrated oscillator and indicating instrument are available, whereby such adjustments can be successfully carried out.

In any repairs or adjustments, the above remarks in regard to the coil assembly should be carefully noted.

3. OPERATION:

(a) When short-wave reception is desired, the selector switch (left-hand knob) should be turned to the right after switching the power on with the right-hand knob on the selector. The standard receiver should be tuned to 600KC (500 metres), and left in that position. The exact position can be determined by rocking the dial of the broadcast receiver around this position until the maximum noise level or hiss is obtained. The hiss will not be very loud, as the selector has been designed for low noise level.

All tuning will now be done on the selector, the desired volume level being obtained by using the volume control on the standard receiver.

4. VALVES:

All Receivers leaving the factory are equipped with valves inserted into the sockets. If for any reason it becomes necessary to remove the valves, care should be taken to see that each one is replaced in the socket from which it was taken. The photograph of the chassis on page 1 shows the type and function of the valves and their exact location.

Function of Valve.	Type of Valve.
R.F.	6D6
Pentagrid Converter	6A7
Rectifier	80

5. VOLTAGES:

Valve.	Plate.	Screen.	Cathode.
6D6	240	95	-3
6A7	240	95	-3
Oscillator Section	160	—	—

The voltmeter used should have an internal resistance of 1000 ohms per volt, and all voltages are measured from the above designated valve prongs to chassis, with the line voltage at 240.

6. COMPONENTS:

The numbers refer to the position of the components on the assembly panel.

- | | |
|-----------------|-----------------|
| 1. Blank. | 4. 50,000 ohms. |
| 2. 50,000 ohms. | 5. 300 ohms. |
| 3. 50,000 ohms. | 6. 300 ohms. |

N.B.—BEFORE LEAVING A STROMBERG-CARLSON RADIO RECEIVER IN A CUSTOMER'S HOME, SEE THAT EVERYBODY WHO IS LIKELY TO HANDLE THE RECEIVER FULLY UNDERSTANDS ITS OPERATION. BY SO DOING MANY

Stromberg-Carlson

SERVICE BULLETIN No. 36

Radio Receiver Model 36

ALL-ELECTRIC, SCREEN-GRID, THREE VALVES
AND RECTIFIER

For all Receivers of this Model with Serial Numbers under 5000—
(for Receivers with Serial Numbers over 5000 see Service Manual
No. 36A.)

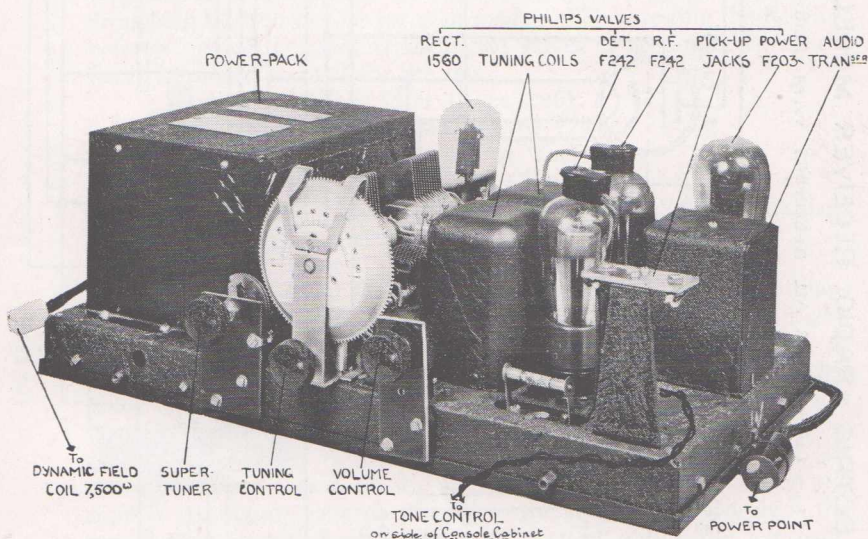

Chassis of 36 Model

This Service Bulletin is issued free of charge to all Authorised Stromberg-Carlson Distributors and Dealers. Applications for additional copies should be made direct to Stromberg-Carlson (Australasia) Ltd.

STROMBERG - CARLSON

SERVICE BULLETIN No. 36 (Continued)

Radio Receiver Model 36

ALL-ELECTRIC, SCREEN-GRID, THREE VALVES AND RECTIFIER.

This Receiver utilises our original Model 44 Chassis and Pack Can, but with improved Power Transformer and Filter.

Circuit.

One stage of Screen-Grid Radio Frequency, Screen-Grid Detector, and one Power Audio (Type 245).

General.

Instal in accordance with the instructions in the General Service Bulletin, taking care to check up the A.C. Line Voltage. The Receiver, except in special cases, is issued for use on 240-volt Circuits. If the locality is a different voltage supply, or is subject to high voltage fluctuations refer to the diagram and alter tappings accordingly. The Receiver should be connected up in accordance with the instructions accompanying it, and particular attention should be paid to making the earth connection as short and direct as possible, whilst the aerial should be of such length (generally from twenty-five to forty feet) as will give the most satisfactory results for selectivity.

Valves.

Philips Valves are tested, matched and supplied in sealed standard Stromberg-Carlson cartons for each model. When testing the Receiver before issue to the customer the actual valves to be supplied with the Receiver should be used for the test.

Rectifier: Philips 1560 (Type 280).

R.F. Stage: Philips F.242 (Type 224).

Detector: Philips F.242 (Type 224).

Power Audio: Philips F.203 (Type 245).

Dial Lamp: 2.5 volt circuit, but 3.8 or 4 volt lamp is utilized to ensure long service.

Speaker.

This Model is designed for a Dynamic Type Speaker with 7500 ohms D.C. field coil, and lead wires are furnished to supply the field coil.

Operation.

This Receiver is not of the re-generator type, but the facilities provided allow for such fine tuning that it may be brought to oscillation point when it is desired to get maximum selectivity and sensitivity. The centre control knob is the station selector. The knob on the left provides vernier tuning on the aerial circuit, whilst the knob on the right is the volume control. Fitted to the side of the Console is the special tone control knob. For good average results the left hand knob may be set in the most suitable position for the particular aerial being used, and need not be further used except on special occasions.

TECHNICAL DESCRIPTION.

(To be read in conjunction with Drawing No. 14)

The **Power Transformer** is of the layer wound type, with tapped primary to suit various line voltages from 225-275. These tappings are brought out on a strip attached to the Power Transformer. The Power Transformer and Filter Apparatus are mounted on a plate,

STROMBERG - CARLSON

SERVICE BULLETIN No. 36 (Continued)

which fits into the Power Pack Can. Should it be necessary to alter the taps, slot the top of the holes in the side of the Power Can, and the Power Pack may then be lifted out without the necessity of unsoldering the wires beneath the Receiver.

Two centre tapped 2.5 volt windings supply the filaments, one for the R.F. and Detector stage and the other for the Power Audio. A 4.8 volt winding furnishes current for the Rectifier filament with a 650 volt centre tapped winding for the Rectifier Plates.

The **Power Filter** consists of two tapped filter chokes with specially tested filter Condensers. These chokes and condensers are mounted on a plate with the Power Transformer and housed in the one Power Can. The **Tuning Condensers** are our 23 plate brass type with a five plate vernier tuning condenser on the aerial. The Tuning Coils are specially matched in conjunction with the Tuning Condenser and are shielded with drawn copper shields.

The **Potential Divider** is located beneath the Chassis, whilst the bias resistance R.3, 1450 ohms is wound on a bobbin and by-passed with the 2 m.f. Condenser C.5.

The **Audio Transformer** A.T.1 is our standard heavy core type No. 44 Radio 4-1 with a high impedance primary suitable for the Screen-Grid Detector.

The **Volume Control** is a 900 ohm, wire wound, Potentiometer, which controls the grid bias on the R.F. Valve.

Pick-Up Terminals are provided. If when installing a Pick-Up the switch is required, it should be inserted in the Grid Lead, not more than 6 inches from the Pick-Up Jack.

Voltages.

R.F.—A. 2.35 to 2.5 volts.

B. 120/140 volts.

C. 1.5—12 volts according to position of Volume Control.

D. (Screen) 50/60 volts.

Detector—A. 2.35/2.5 volts.

B. 200/275 volts.

Power Audio—A. 2.35/2.5 volts.

B. 200/215 volts.

C. 35/40 volts.

Rectifier—A. 4.8 volts.

B. 650 volts across plates.

Faults.

Refer to General Service Bulletin, Pages 7-10, for general faults which may occur. The following faults may occur through rough handling in transport:—

No Signals.—Examine Super-tuner five-plate Condenser for short circuit—also main tuning gang. See that connections to tuning coils are not open circuit.

Replacement Parts.

When ordering replacement parts mention, wherever possible, the indicating letter and number shown on the drawing for the particular part you require.

Stromberg-Carlson

SERVICE BULLETIN No. 45

Radio Receiver Model 45

ALL-ELECTRIC, SCREEN-GRID, FOUR VALVES

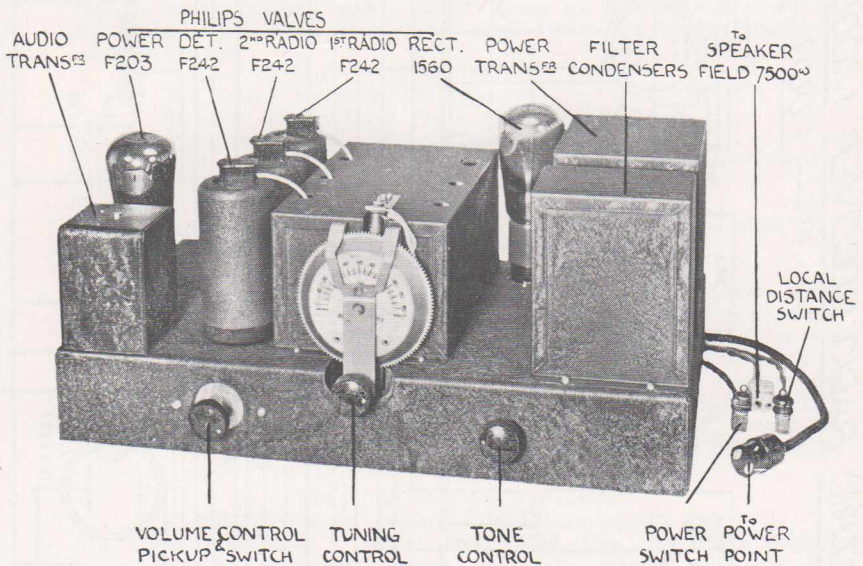

Chassis of 45 Model

This Service Bulletin is issued free of charge to all Authorised Stromberg-Carlson Distributors and Dealers. Applications for additional copies should be made direct to Stromberg-Carlson (Australasia) Ltd.

— ALL ELECTRIC RADIO RECEIVER MODEL - 45 —
— FOUR VALVES AND RECTIFIER —

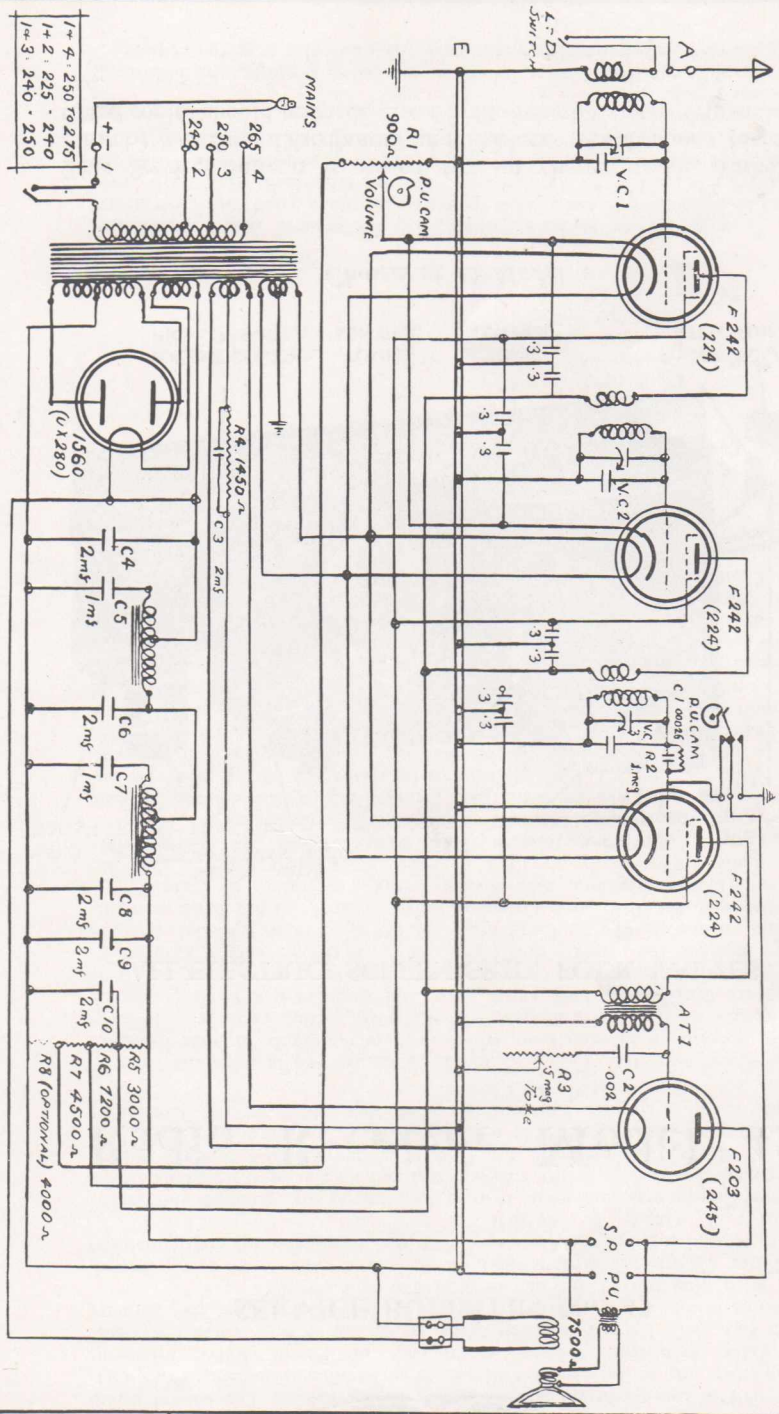

CHANGES

DRAWN. J.S.
EXAMINED BY
APPROVED BY
DIRECTOR
APRIL 28 1931

STROMBERG CARLSON AUSTRALASIA
SYDNEY LIMITED
DRAWING No 16

STROMBERG - CARLSON

SERVICE BULLETIN No. 45 (*Continued*)

Radio Receiver Model 45

ALL-ELECTRIC, SCREEN-GRID, FOUR VALVES AND RECTIFIER.

This Receiver is built on the same size Chassis as the Model 36 Receiver described in Service Manual 36A, and is equipped with our new standard Power Plant, together with our new standard three gang, straight line frequency condensers and individual valve shields.

Circuit.

Two stages of tuned screen-grid R.F. screen-grid Detector and one type 245 Power Audio.

General.

Instal in accordance with the instructions in the General Service Bulletin, taking care to check up the A.C. Line Voltage. The Receiver, except in special cases, is issued for use on 240 volt Circuits. If the locality is a different voltage supply or is subject to high voltage fluctuations, refer to the diagram and alter tapings accordingly. The Receiver should be connected up in accordance with the instructions accompanying it, and particular attention should be paid to making the earth connection as short and direct as possible, whilst the aerial should be of such length (generally twenty-five to forty feet) as will give the most satisfactory results for selectivity.

Valves.

Philips Valves are tested, matched and supplied in sealed standard Stromberg-Carlson cartons for each model. When testing the Receiver before issue to the customer, the actual valves to be supplied with the Receiver should be used for the test.

Rectifier: Philips 1560 (Type 280).

R.F. Stages: Philips F.242 (Type 224).

Detector: Philips F.242 (Type 224).

Power Audio: Philips F.203 (Type 245).

Dial Lamp: 2.5 volt circuit, but 3.8 or 4 volt lamp is utilised to ensure long service.

Speaker.

This Model is designed for a Dynamic type Speaker, with 7500 ohms D.C. Field coil and lead wires are furnished to supply the field coil.

Operation.

This Receiver is not of the regenerator type. The centre control knob is the Station Selector. The knob on the left is the volume control which when turned right off automatically switches on the Pick-Up. The knob on the right is the tone control. At the left of the Cabinet is a switch which in one position makes for better reception of nearby Broadcasting Stations, and in the other position makes for greater sensitivity on distant Stations. This is called the Local Distant Switch. On the other side of the Cabinet is the Power Switch allowing of the Receiver to be switched on and off independently of the switch at the electric power socket.

TECHNICAL DESCRIPTION.

(*To be read in conjunction with Drawing No. 16*)

The Power Transformer is of the layer wound type, with tapped primary to suit various line voltages, from 225-275 volts. If voltage is less than 225 a special transformer is provided.

The core of laminated stalloy is oversize. The windings are brought out by means of high grade insulated flexible wires, and the Transformer is sealed in a steel container with the highest grade insulating compound of a high melting point. The wires from the Transformer terminate on a double terminal strip beneath the chassis and this facilitates testing. The colour code for the wires leading from the Transformer are as under, but servicemen are warned that this colour code may be slightly changed from time to time owing to wire manufacturers being unable to furnish the necessary colours when required.

COLOUR CODE.

Black, start of primary; *Green*, No. 2 tap; *Blue*, No. 3 tap; *Red*, No. 4 tap; *Whites* (2), start and finish of high tension; *Maroon*, centre tap of high

STROMBERG - CARLSON

SERVICE BULLETIN No. 45 (Continued)

tension. All of the above are taped together in one cable. The second group taped together are as follows:—*Yellows* (2), Rectifier Filament; *Reds* (2), Power Valve Filament; *Maroon*, centre tap of Power Valve Filament; *Spagbetti* (2), A.C. Valve Filaments; *Black*, centre tap of A.C. Valve Filaments. **NOTE.**—In some transformers an extra tap is furnished on the primary (orange with blue tracer) for use on 200/220 volt circuits.

Power Filter Chokes are layer wound on two cores, each choke being tapped. These are located beneath the Chasses. Each coil terminates on a strip marked "S" (start), "T" (tap), "F" (finish).

The **Filter Condensers** and main by-pass Condensers are grouped and sealed with a special preparation in the smaller steel can on top of the Chassis. One side of all of the Condensers in the Pack is commoned and brought out by means of one red lead. Each blue lead represents 1 m.f. and each black lead represents 2 m.f. By-pass Condensers, other than those in the Condenser Pack Can, are located beneath the Chassis.

NOTE.—Condensers C.2, C.3, C.4, and C.13 are located beneath the Chassis. C.13 is to prevent modulation hum, which is more noticeable in some localities than in others, and which is aggravated usually by a long earth wire. These Receivers are tested on a long earth wire, and Condenser C.13 is connected in the most effective way in each particular Receiver. In some cases it is connected between the primary and earth. It is, of course, a mica Condenser. Two banks of special by-pass Condensers are provided in this Model, and are located between the R.F. and Detector Valve sockets. Each bank contains four .3 m.f. Condensers, one side of each being common to the case.

Tuning Coils are specially shielded in solid drawn copper cans, and are easily removable. To remove coil, unsolder wires, take out the central single screw from the base plate, and the coil immediately comes clear.

Pick-Up Switch. As will be seen from the drawing, a cam on the Volume Control Spindle causes the Pick-Up lead to be connected to the grid. When radio is in use the cam disconnects this Pick-Up lead and connects it to earth.

Audio Transformer is a special 4-1 heavy core type with a high impedance layer wound primary to suit the screen-grid detector.

Tuning Condensers (3 gang) are of the straight line frequency type. Should it be necessary to reline the aerial Condenser to suit any particular aerial, this should be done by means of a fibre tube through the hole nearest the back of the covering can. If a tube is not available use a screwdriver very carefully. Do not line up on any station below 25 on the dial.

Volume Control is a wire wound potentiometer, 900 ohms, controlling the grid bias on the radio frequency valves.

Voltages—R.F.—A. 2.35 to 2.5 volts.

B. 180/200 volts.

C. 1-12 volts according to position of volume control.

D. (Screen) 80-85 volts.

Detector—A. 2.35 to 2.5 volts.

B. 180/200 volts.

C. Nil.

D. 80/85.

Power Audio—A. 2.35 to 2.5 volts.

B. 240/250 volts.

C. 45/50 volts.

Rectifier—A. 4.8 volts to 5 volts.

B. 700/750 volts across plates.

Faults.

Refer to General Service Bulletin, pages 7-10, for general faults which may occur, but this Receiver is built with apparatus having a good factor of safety, and little trouble should be experienced. As we frequently meet with cases where faulty or unreliable rectifier valves are used, and so cause serious damage to the Power Unit, particular care should be taken to see that the valves we supply or recommend are used with the Receiver.

Replacement Parts.

When ordering replacement parts, mention, whenever possible, the indicating letter and number shown on the drawing for the particular part you require.

Stromberg-Carlson

STROMBERG - CARLSON

SERVICE BULLETIN No. 53

Stromberg-Carlson Model 53 Superheterodyne

ALL ELECTRIC FOUR VALVES AND RECTIFIER

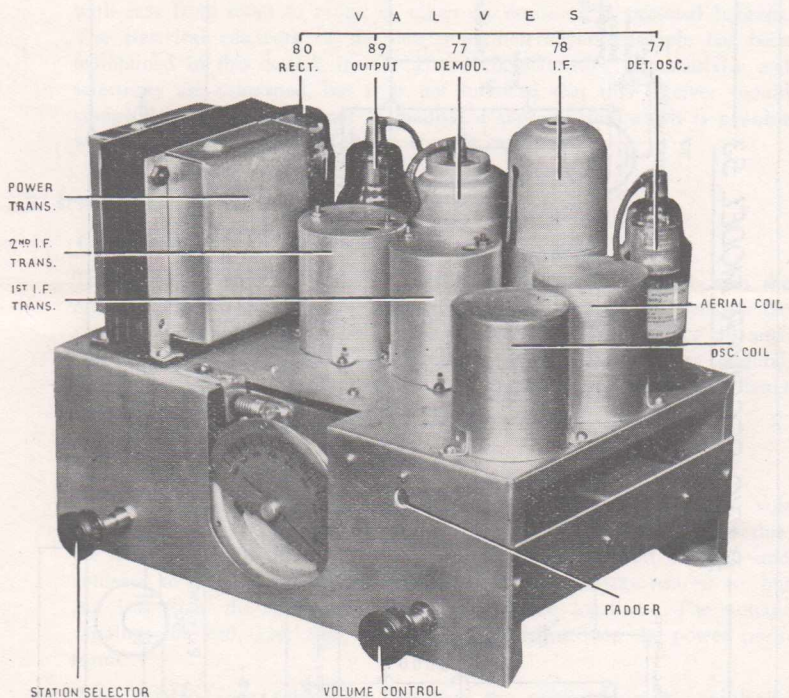

Chassis of Model 53

This Service Bulletin is issued free of charge to all authorised Stromberg-Carlson Dealers. Applications for additional copies should be made direct to the nearest Distributor.

Stromberg-Carlson (Australasia) Ltd. reserve the right to make changes in design details at any time without incurring any obligations to instal same on radio receivers previously sold.

STROMBERG-CARLSON (AUSTRALASIA) LIMITED
 SYDNEY AUSTRALIA

DRAWING No Z138

CHANGES

DRAWN J.W.S.
 EXAMINED [Signature]
 APPROVED [Signature]

DATE 25-7-'33

RADIO RECEIVER MODEL 53

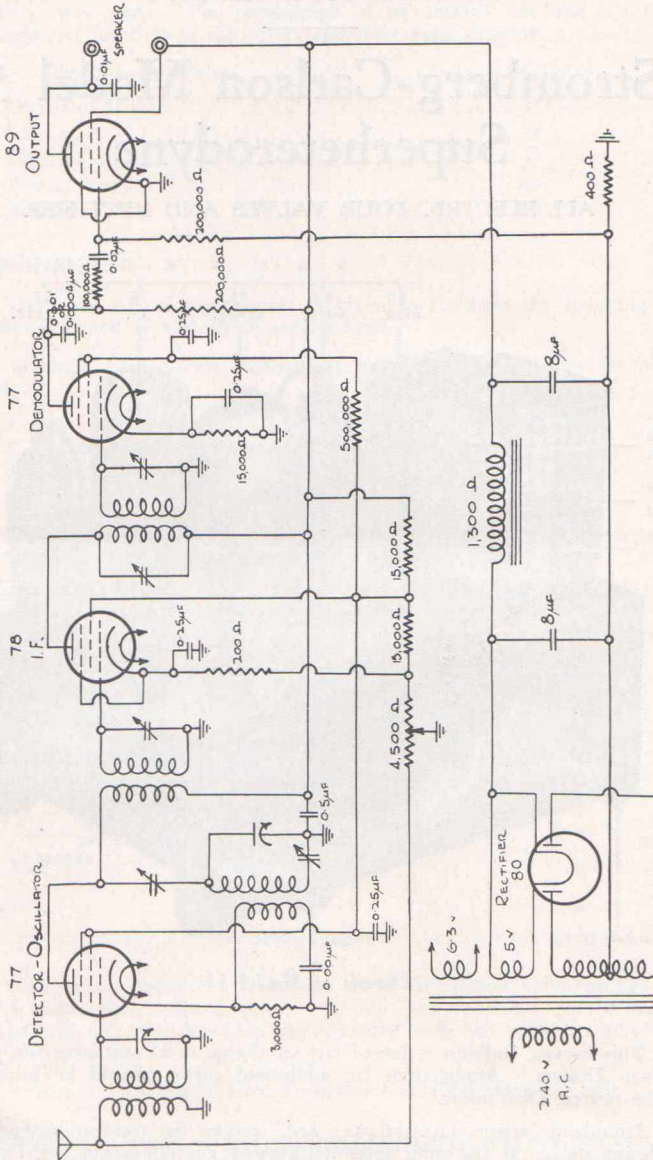

STROMBERG - CARLSON

SERVICE BULLETIN No. 53 (Continued)

Page 3

Stromberg-Carlson Model 53 Superheterodyne

ALL ELECTRIC FOUR VALVES AND RECTIFIER

1. GENERAL DESCRIPTION OF RECEIVER:

This receiver has been designed as a compact and portable model for use where such attributes are of primary importance.

The 53 Model is particularly adaptable as an additional receiver in the home for use in bedrooms, lounge room, verandahs, etc. It may be carried with ease from room to room, or taken on vacations as personal luggage. The electrical efficiency of the new super-heterodyne principle has been maintained in this model, insofar as the characteristics of sensitivity and selectivity are concerned, but it is not intended that this receiver should compete in the power output or quality of reproduction which is possible with the larger Stromberg-Carlson console models.

2. INSTALLATION INSTRUCTIONS:

(a) Aerial.

The sensitivity of this model is such that the aerial supplied with the receiver, placed along the picture moulding in a room, or beneath the carpet, will prove satisfactory. Care should be taken to place all such indoor aerials, as far away as possible from electric light or power conduits, and in particular, clear of all unshielded flexible leads, since these latter are prolific radiators of undesirable electrical impulses.

(b) Voltage Adjustment Panel.

Before leaving the factory the power lead is connected to the 240 volt tapping on the power transformer. If the line voltage differs from this, the power lead should be unsoldered from the 240 volt tapping and soldered to the tapping which is marked with the voltage nearest to, but not less than, the measured line voltage in the locality. The voltage tappings for 200, 220, 240, 260 volts are designated on the power transformer.

When making any adjustment, see that the power plug is completely removed from the socket of the supply source.

(c) Trimmer Adjustments.

The tuning adjustments on the gang capacitor (the variable gang tuning condenser) and the trimmer capacitors on the Intermediate Frequency Transformers (tuned to 465 k.c.) are adjusted at the factory at the time of calibration. These adjustments should on no account be touched unless a specially calibrated oscillator and indicating instrument are available whereby such adjustments can be successfully carried out. In any repairs or adjustments the above remarks in regard to the gang capacitor and intermediate transformers should be carefully noted.

STROMBERG - CARLSON

SERVICE BULLETIN No. 53 (Continued)

Page 4

3. VALVES:

All Receivers leaving the factory are equipped with valves inserted into the sockets. If for any reason it becomes necessary to remove the valves, care should be taken to see that each one is replaced in the socket from which it was taken. The photograph of the chassis on Page 1 shows the type and function of the valves and their exact location.

Function of Valve.	Type of Valve.
Oscillator-Mixer	77
I.F.	78
Detector	77
Power Pentode	89
Rectifier	80

4. COMPONENTS:

The following list of components is given to facilitate the servicing of the Receiver and as a guide to replacements.

The numbers refer to the position of the component on the assembly panel.

- | | |
|--------------------|---------------------|
| 1. .001 microfarad | 8. .0004 microfarad |
| 2. 3000 ohms | 9. 200,000 ohms |
| 3. 15,000 ohms | 10. 100,000 ohms |
| 4. 15,000 ohms | 11. .02 microfarad |
| 5. 200 ohms | 12. 200,000 ohms |
| 6. 15,000 ohms | 13. 400 ohms |
| 7. 500,000 ohms | 14. .01 microfarad |

Capacitor block: 4 red leads 0.25 microfarad.
1 yellow lead 0.5 microfarad.

5. VOLTAGES:

Valve.	Screen	Plate	Cathode
Det.-Osc. 77	85, 110*	190	5
I.F. 78	85, 110*	190	2, 45*
2nd Det. 77	12, 15*	—	4
Output 89	190	190	0

All voltages are measured from the above designated valve prongs to chassis base, with volume control at full "on" position, except those marked with an asterisk which are measured with the volume control at the "off" position.

The voltmeter used should have a resistance of 1000 ohms per volt.

N.B.—BEFORE LEAVING A STROMBERG-CARLSON RADIO RECEIVER IN A CUSTOMER'S HOME, SEE THAT EVERYBODY WHO IS LIKELY TO HANDLE THE RECEIVER FULLY UNDERSTANDS ITS OPERATION. BY SO DOING MANY UNNECESSARY SERVICE CALLS WILL BE AVOIDED.

Stromberg-Carlson

STROMBERG-CARLSON
SERVICE BULLETIN No. 54

Stromberg-Carlson Model 54 UNIVERSAL A.C.-D.C. Superheterodyne

ALL ELECTRIC FOUR VALVES AND RECTIFIER

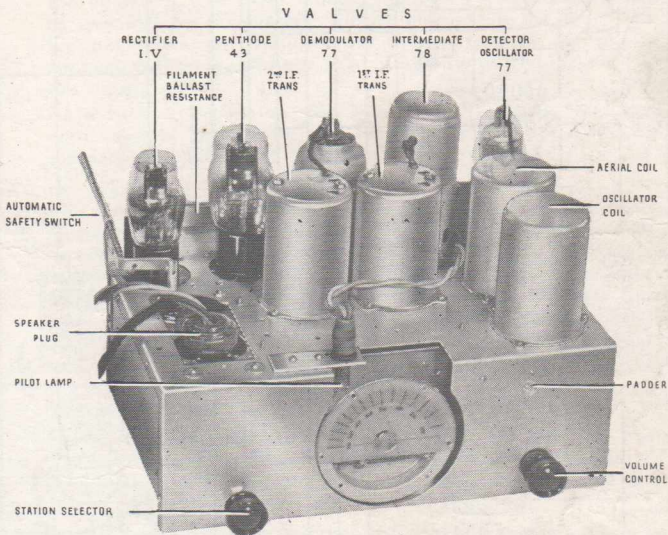

Chassis of Model 54

This Service Bulletin is issued free of charge to all authorised Stromberg-Carlson Dealers. Applications for additional copies should be made direct to the nearest Distributor.

Stromberg-Carlson (Australasia) Ltd. reserve the right to make changes in design details at any time without incurring any obligations to instal same on radio receivers previously sold.

Stromberg-Carlson Model 54**UNIVERSAL A.C.-D.C.****Superheterodyne****ALL ELECTRIC FOUR VALVES AND RECTIFIER****1. GENERAL DESCRIPTION OF RECEIVER:**

The Universal A.C.-D.C. Model is particularly adapted to areas where the electric supply is direct current.

A number of such areas are at present in the process of conversion to an alternating current supply. In these circumstances the 54 Receiver is ideal, in that it operates with equal efficiency on either A.C. or D.C. supplies.

The electrical efficiency, compactness and portability of the 53 "Younger Set" Model have been maintained in the 54 Universal Model.

2. INSTALLATION INSTRUCTIONS:**(a) Safety.**

Every precaution has been taken to render the 54 A.C.-D.C. Receiver perfectly safe. Nevertheless, due care should be exercised in the installation of this type of receiver. The metal gauze, which protects the chassis in the table model, should be connected to a good earth, as specified by the electric supply authorities.

Do not make any adjustments to the receiver, aerial, or any lead connected thereto, without first of all disconnecting the receiver from the supply mains.

As a further protection, the 54 chassis has been fitted with an automatic switch, which—on the removal of the protective back on the cabinet—opens both of the power leads to the chassis.

(b) Aerial.

The sensitivity of this model is such that the aerial supplied with the receiver, placed along the picture moulding in a room, or beneath the carpet, will prove satisfactory. Care should be taken to place all such indoor aerials as far away as possible from electric light or power conduits, and, in particular, clear of all unshielded flexible leads, since these latter are prolific radiators of undesirable electrical impulses.

CAUTION. When an outdoor aerial is installed on any A.C.-D.C. receiver, care should be taken to place the aerial well clear of buildings, and to particularly avoid any possibility of bodily contact being made between the aerial and any metal roofing.

In the Stromberg-Carlson A.C.-D.C. Model the aerial is normally protected by two specially selected condensers. Only on the very remote possibility of the two condensers breaking down would there be any danger from contact with the aerial circuit.

(c) Voltage Adjustment Panel and Power Connections.

Before leaving the factory the power lead is connected to the 240 volt tapping on the ballast resistor. If the line voltage differs from this, the power lead should be unsoldered from the 240 volt tapping and soldered to the tapping which is marked with the voltage nearest to, but not less than, the measured line voltage in the locality. The voltage tappings for 220, 240, 260 volts are designated on the ballast resistor. The three-wire power cable consists of the two power leads, red and black, and an earth lead, green.

When connected to D.C., it is imperative that the RED lead be connected to the POSITIVE and the BLACK to the NEGATIVE of the supply mains. If reversed the filaments will light but the receiver will not operate.

When connected to A.C. it is preferable for the RED lead to be connected to the ACTIVE and the BLACK to the NEUTRAL of the supply mains.

STROMBERG - CARLSON

Note.—To ascertain ACTIVE, check with test lamp (240 volt) between line and earth. The ACTIVE will be indicated by the lamp lighting. No light will be observed between NEUTRAL and earth.

When making any adjustment, see that the power plug is completely removed from the socket of the supply source.

(d) Trimmer Adjustments.

The tuning adjustments on the gang capacitor (the variable gang tuning condenser) and the trimmer capacitors on the Intermediate Frequency Transformers (tuned to 465 k.c.) are adjusted at the factory at the time of calibration. These adjustments should on no account be touched unless a specially calibrated oscillator and indicating instrument are available whereby such adjustments can be successfully carried out. In any repairs or adjustments the above remarks in regard to the gang capacitor and intermediate transformers should be carefully noted.

3. VALVES:

All Receivers leaving the factory are equipped with valves inserted into the sockets. If for any reason it becomes necessary to remove the valves, care should be taken to see that each one is replaced in the socket from which it was taken. The photograph of the chassis on Page 1 shows the type and function of the valves and their exact location.

Function of Valve.	Type of Valve.
Oscillator-Mixer	77
I.F.	78
Detector	77
Power Pentode	43
Rectifier	1.V.

4. COMPONENTS:

The following list of components is given to facilitate the servicing of the Receiver and as a guide to replacements.

The numbers refer to the position of the component on the assembly panel.

1. .001 microfarad	8. .001 microfarad
2. 5000 ohms	9. 200,000 ohms
3. 11,000 ohms	10. 100,000 ohms
4. 11,000 ohms	11. .02 microfarad
5. 200 ohms	12. 500,000 ohms
6. 15,000 ohms	13. 25 microfarads + 500 ohms
7. 500,000 ohms	14. .004 microfarad

Capacitor block: 4 red leads 0.25 microfarad.
1 yellow lead 0.5 microfarad.

5. VOLTAGES:

Valve.	Screen.	Plate.	Cathode.
Det.-Osc. 77	65, 85*	155	5
I.F. 78	65, 85*	155	2, 35*
2nd Det. 77	20	50	3
Output 43	155	155	20

All voltages are measured from the above designated valve prongs to the common negative bus, with volume control at full "on" position, except those marked with an asterisk, which are measured with the volume control at the "off" position.

The voltmeter used should have a resistance of 1000 ohms per volt.

N.B.—BEFORE LEAVING A STROMBERG-CARLSON RADIO RECEIVER IN A CUSTOMER'S HOME, SEE THAT EVERYBODY WHO IS LIKELY TO HANDLE THE RECEIVER FULLY UNDERSTANDS ITS OPERATION. BY SO DOING MANY UNNECESSARY SERVICE CALLS WILL BE AVOIDED.

Stromberg-Carlson

STROMBERG-CARLSON
SERVICE BULLETIN No. 55A

Stromberg-Carlson Model 55A UNIVERSAL A.C.-D.C. Superheterodyne

ALL-ELECTRIC, FOUR VALVES AND RECTIFIER

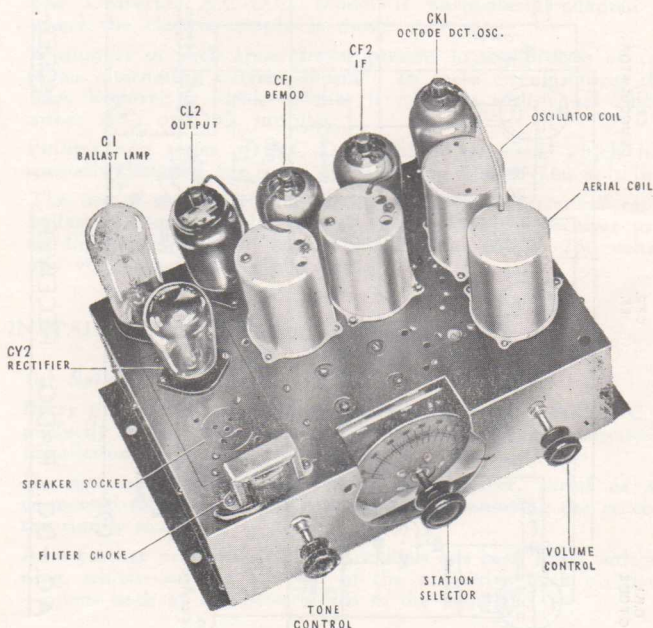

Chassis of Model 55A

This Service Bulletin is issued free of charge to all authorised Stromberg-Carlson Dealers. Applications for additional copies should be made direct to the nearest Distributor.

Stromberg-Carlson (Australasia) Ltd. reserves the right to make changes in design details at any time without incurring any obligations to install same on radio receivers previously sold.

Stromberg-Carlson Model 55A

UNIVERSAL A.C.-D.C.

Superheterodyne

ALL-ELECTRIC, FOUR VALVES AND RECTIFIER

1. GENERAL DESCRIPTION OF RECEIVER:

The Universal A.C.-D.C. Model is particularly adapted to areas where the electric supply is direct current.

A number of such areas are at present in the process of conversion to an alternating current supply. In these circumstances the model 55A Receiver is ideal, in that it operates with equal efficiency on either A.C. or D.C. supplies.

Philip's new series of A.C.-D.C. Valves are used, which have been specially designed for series operation on 200 to 260 volt lines.

The use of the current regulating tube, the "Barretter" replaces the ballast resistor of earlier models, and allows the receiver to be used on lines in which the voltage varies from 160 to 260 volts without any voltage taps being changed.

2. INSTALLATION INSTRUCTIONS:

(a) Safety.

Every precaution has been taken to render the 55A A.C.-D.C. Receiver perfectly safe. Nevertheless, due care should be exercised in the installation of this type of receiver.

Do not make any adjustment to the receiver, aerial or any lead connected thereto, without first of all disconnecting the receiver from the supply mains.

As a further protection, the 55A chassis has been fitted with a two-pin plug, which—on the removal of the protective back on the cabinet—opens both of the power leads to the chassis.

(b) Aerial.

The sensitivity of this model is such that an aerial placed along the picture moulding in a room, or beneath the carpet, will prove satisfactory. Care should be taken to place all such indoor aerials as far away as possible from electric light or power conduits, and, in particular, clear of all unshielded flexible leads, since these latter are prolific radiators of undesirable electrical impulses.

CAUTION.—When an outdoor aerial is installed on any A.C.-D.C. receiver, care should be taken to place the aerial well clear of buildings, and to particularly avoid any possibility of bodily contact being made between the aerial and any metal roofing.

SERVICE BULLETIN No. 55A (Continued)

In the Stromberg-Carlson A.C.-D.C. Model the aerial is normally protected by two specially selected condensers. Only on the very remote possibility of the **two condensers** breaking down would there be any danger from contact with the aerial circuit.

When connected to D.C., it is imperative that the **RED** lead be connected to the **POSITIVE**, and the **BLACK** to the **NEGATIVE** of the supply mains. If reversed the filaments will light, but the receiver will not operate.

When connected to A.C. it is preferable for the **RED** lead to be connected to the **ACTIVE**, and the **BLACK** to the **NEUTRAL** of the supply mains.

Note.—To ascertain **ACTIVE**, check with test lamp (240 volt) between line and earth. The **ACTIVE** will be indicated by the lamp lighting. No light will be observed between **NEUTRAL** and earth.

When making any adjustment, see that the **power plug** is completely removed from the socket of the supply source.

(d) Trimmer Adjustments.

The tuning adjustments on the gang capacitor (the variable gang tuning condenser) and the trimmer capacitors on the Intermediate Frequency Transformers are adjusted at the factory at the time of calibration. These adjustments should on no account be touched unless a specially calibrated oscillator and indicating instrument are available whereby such adjustments can be successfully carried out. In any repairs or adjustments the above remarks in regard to the gang capacitor and intermediate transformers should be carefully noted.

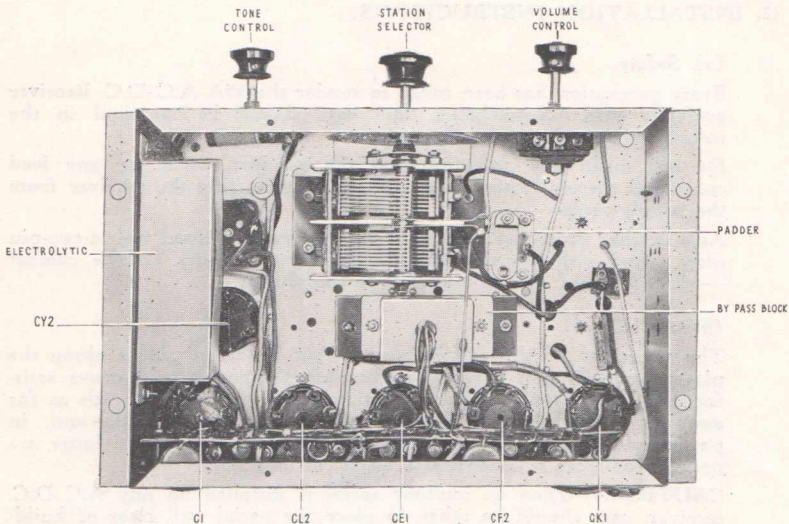

Under Chassis View of Model 55A

SERVICE BULLETIN No. 55A (Continued)

3. VALVES:

All Receivers leaving the factory are equipped with valves inserted into the sockets. If for any reason it becomes necessary to remove the valves, care should be taken to see that each one is replaced in the socket from which it was taken. The photograph of the chassis on page 1 shows the type and function of the valves and their exact location.

Function of Valve.	Type of Valve.
Octode Oscillator-Mixer	CK1
I.F.	CF2
Detector	CF1
Power Pentode	CL2
Rectifier	CY1
"Barretter" Ballast Lamp	C1

4. COMPONENTS:

The following list of components are given to facilitate the servicing of the receiver and as a guide to replacement.

The numbers refer to position of the components on the assembly panel.

- | | |
|------------------------|-------------------------|
| 1. 50,000 microfarad. | 9. .0001 ohm. |
| 2. .1 ohm. | 10. 100,000 ohms. |
| 3. 200 ohms. | 11. .02 microfarad. |
| 4. 25 microfarad. | 12. .004 ohm. |
| 5. 15,000 ohms. | 13. 200,000 microfarad. |
| 6. 20,000 ohms. | 14. .02 microfarad. |
| 7. 20,00 ohms. | 15. 400-2 |
| 8. 200,000 microfarad. | 16. 25 microfarad. |

Capacitor Block: 4 red leads, 0.25 microfarad.
1 yellow lead, 0.5 microfarad.

5. VOLTAGES:

Valve.	Plate.	Screen.	Cathode.
Octode Det.-Osc. CK1	50	200	1.5 to 7
I.F. CF2	50	200	1.5 to 7
2nd Det. CF1	50	80	2
Output CL2	150	180	17

All voltages are measured from the above designated valve prongs to the common negative bus, with volume control at full "on" position, except those marked with an asterisk, which are measured with the volume control at the "off" position.

The voltmeter used should have a resistance of 1000 ohms per volt. Note.—All screens are series fed through resistances so that indicated voltage will vary slightly when different types of meters are used to measure the voltage.

N.B.—BEFORE LEAVING A STROMBERG-CARLSON RADIO RECEIVER IN A CUSTOMER'S HOME, SEE THAT EVERYBODY WHO IS LIKELY TO HANDLE THE RECEIVER FULLY UNDERSTANDS ITS OPERATION. BY SO DOING MANY UNNECESSARY SERVICE CALLS WILL BE AVOIDED.

STROMBERG-CALSON

The following is a list of the various items...

- 1000
- 1000
- 1000
- 1000
- 1000
- 1000
- 1000
- 1000

The following is a list of the various items...

- 1000
- 1000
- 1000
- 1000
- 1000
- 1000
- 1000
- 1000

Category	Item	Value	Total
...
...
...
...

The following is a list of the various items...

UNIVERSITY SERVICE CALLS WILL BE ANSWERED...

Stromberg-Carlson

STROMBERG-CARLSON
SERVICE BULLETIN, No. 56/565

Stromberg-Carlson Models 56/565 Superheterodyne

ALL-ELECTRIC, FOUR VALVES AND RECTIFIER

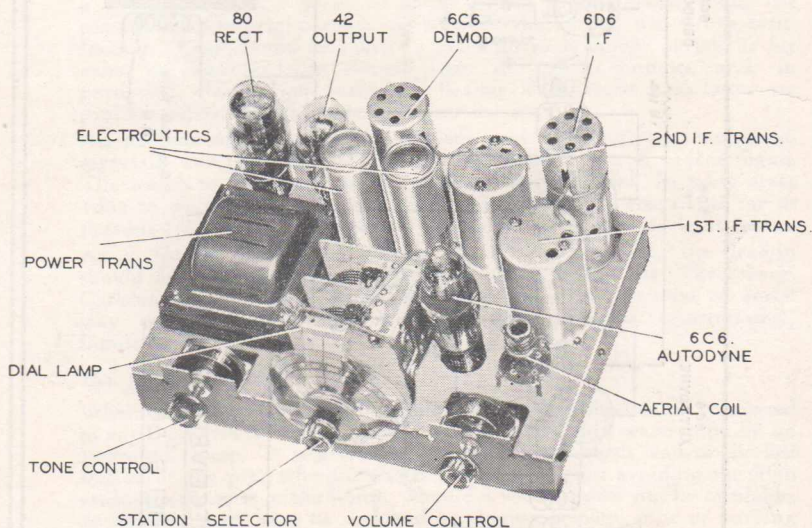

Chassis of 56/565 Model.

This Service Bulletin is issued free of charge to all authorised Stromberg-Carlson Dealers. Applications for additional copies should be made direct to the nearest Distributor.

Stromberg-Carlson (Australasia) Ltd. reserves the right to make changes in design details at any time without incurring any obligations to install same on radio receivers previously sold.

STROMBERG - CARLSON (AUSTRALASIA) LIMITED
 SYDNEY, AUSTRALIA

DRAWING No. Z 288

CHANGES

DRAWN *2533*
 EXAMINED
 APPROVED MGN. DIRECTOR
 DATE 6 . 6 . 35

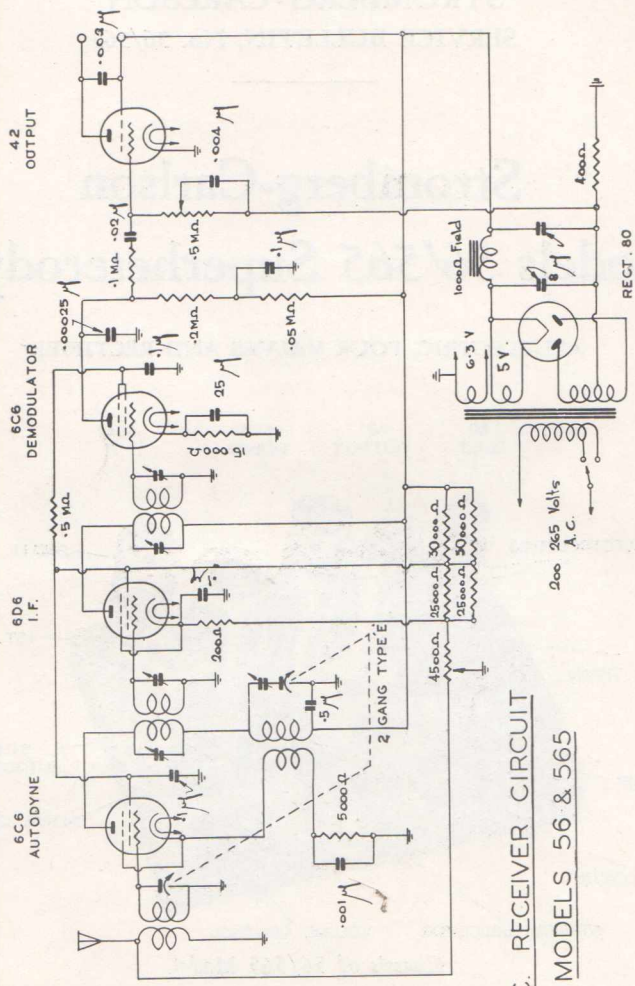

A.C. RECEIVER CIRCUIT
 MODELS 56 & 565

Stromberg-Carlson Models 56/565 Superheterodyne

ALL-ELECTRIC, FOUR VALVES AND RECTIFIER

1. GENERAL DESCRIPTION OF RECEIVER:

This Receiver employs the improved superheterodyne circuit designed and developed in the Stromberg-Carlson laboratories.

By the use of carefully designed components and layout in the chassis it has been possible to achieve exceptional results.

The Model 56 is used in a well-designed mantel cabinet, and the Model 565 is the same chassis in a console cabinet.

2. INSTALLATION INSTRUCTIONS:

(a) Aerial.

The sensitivity of this model is such that for broadcasting reception a well-insulated wire about 20 or 30 feet in length, placed along the picture moulding in a room, or beneath the carpet, will prove satisfactory. Care should be taken to place all such indoor aerials as far away as possible from electric light or power conduits, and, in particular, clear of all unshielded flexible leads, since these latter are prolific radiators of undesirable electrical impulses.

An outdoor aerial is the most efficient, and is strongly recommended, especially for long-distance daylight reception on the broadcast band. The length of this aerial should be from 30 to 50 feet. In noisy areas (due to electrical interference) the aerial should be erected as far as possible from and at right-angles to any electric power or light mains. As a further precaution against undesirable pick-up, the lead-in should be a special shielded type as employed in the "Stromberg-Carlson Aerial Noise Eliminator Kit." Details of this type of aerial may be had on application to Stromberg-Carlson (Australasia), Limited.

(b) Earth.

When required by the wiring rules the chassis should be connected to earth by means of an insulated wire attached to a water pipe by an approved clamp. It is preferable to connect the earth lead to the last section of the pipe where it enters the ground, thus avoiding the high resistance contacts at the joints. Should a water system not be available, an efficient earth may be obtained by driving a metal pipe or burying about four square feet of metal sheeting in moist earth; the connection to the metal should preferably be soldered.

(c) Voltage Adjustment Panel.

Before leaving the factory the voltage switch is set to the 230/260-volt setting. If the line voltage differs from this, the switch should be set to the position nearest to, but not less than the measured line voltage in the locality. The voltage tappings for 200/230, 230/260 volts are designated on the back of the chassis. The adjustment is readily carried out by means of a screwdriver on removing the danger plate.

When making any adjustment, see that the power plug is completely removed from the socket of the supply source.

SERVICE BULLETIN, No. 56/565 (Continued)

(d) Trimmer Adjustments.

The trimmer capacitors on the variable condenser, coil assembly, and the trimmer capacitors on the Intermediate Frequency Transformers (tuned to 460 k.c.) are adjusted and sealed at the factory at the time of calibration. These adjustments should on no account be touched or seals broken unless a specially calibrated oscillator and indicating instrument are available, whereby such adjustments can be successfully carried out.

In any repairs or adjustments, the above remarks in regard to the coil assembly and intermediate transformer should be carefully noted.

3. OPERATION.

(a) The more sensitive and selective the Receiver is the more care should be taken in its operation and tuning to obtain the best results. In Models 56 and 565 the left-hand knob is the "tone control," the centre knob is the tuning control, the right-hand knob is the volume control. Improper tuning will affect the quality of reproduction. Care should be taken to keep the volume control well down, then adjust the tuning control to the point of maximum undistorted signal, thereafter adjusting the volume to the desired level.

(b) Tone Control.

The left-hand knob is the Tone Control. For normal or "brilliant" reception turn Tone Control to right. Where the background of noise is objectionable (as sometimes occurs on long-distance reception) turn the Tone Control to the left.

For the reception of local or strong interstate stations the Tone Control should be at the "brilliant" position in order that the full range of musical frequencies and overtones may be enjoyed.

4. VALVES:

All Receivers leaving the factory are equipped with valves inserted into the sockets. If for any reason it becomes necessary to remove the valves, care should be taken to see that each one is replaced in the socket from which it was taken. The photograph of the chassis on page 1 shows the type and function of the valves and their exact location.

Function of Valve.	Type of Valve.
Autodyne	6C6
I.F.	6D6
Second Detector	6C6
Output	42
Rectifier	80

5. SPEAKER:

The speaker in this Model is the Dynamic or moving coil type and is matched to the output valve. The field coil being used at the date of issue of this Bulletin has a resistance of 1000 ohms. The speaker terminates in a four-pin plug at the Receiver chassis.

THIS PLUG SHOULD NOT BE REMOVED WHILE THE CURRENT IS TURNED ON.

SERVICE BULLETIN, No. 56/565 (Continued)

6. VOLTAGES:

	Valve.	Plate.	Screen.	Cathode.
6C6	Autodyne	250	90	7
6D6	I.F.	250	90	Variable 3 to 35
6C6	Second Detector	—	—	—
42	Output	250	250	—

Bias for the type 42 is obtained by a resistor in the negative lead, and is 16 volts. The plate and screen of the 6C6 second detector are fed through 200,000 ohms and 500,000 ohms respectively from 250 volts and 90 volts respectively.

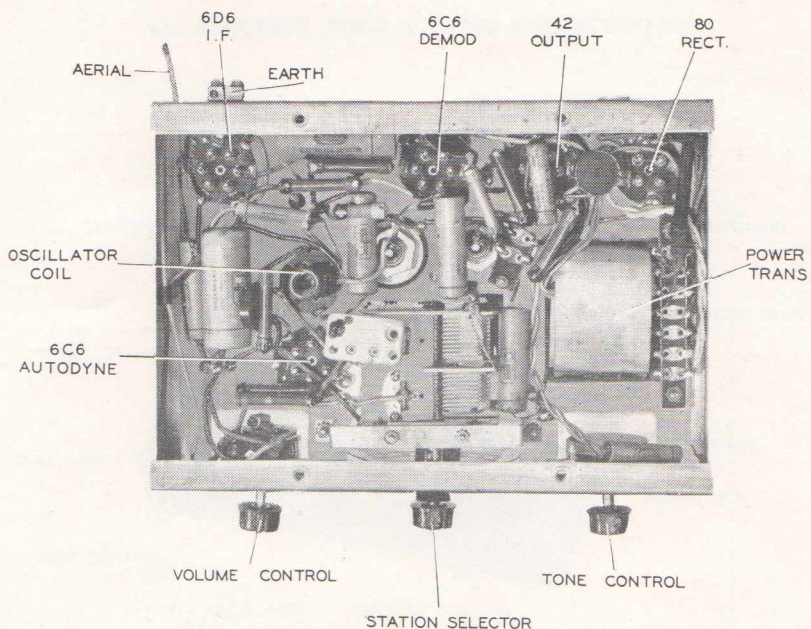

Under Chassis View of Models 56/565

N.B --BEFORE LEAVING A STROMBERG-CARLSON RADIO RECEIVER IN A CUSTOMER'S HOME, SEE THAT EVERYBODY WHO IS LIKELY TO HANDLE THE RECEIVER FULLY UNDERSTANDS ITS OPERATION. BY SO DOING MANY UNNECESSARY SERVICE CALLS WILL BE AVOIDED.

THE SERVICE BULLETIN (Continued)

VEGETABLES

Quantity	Price	Weight	Notes
100	100	100	...
100	100	100	...
100	100	100	...
100	100	100	...

...

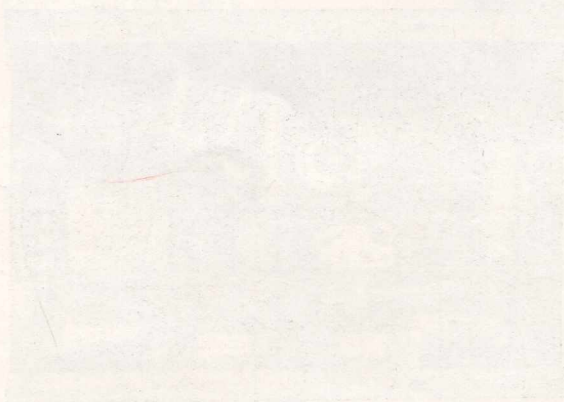

...

...

... LEAVING A STATIONER...
 ... IN A CUSTOMER'S HOME...
 ... TO HANDLE THE RECEIPT...
 ... THE OPERATION BY SO DOING MANY...
 ... SERVICE CALLS WILL BE AVOIDED.

Stromberg-Carlson

SERVICE BULLETIN No. 64

Radio Receiver Model 64

ALL ELECTRIC, SCREEN-GRID, SIX VALVES AND RECTIFIER.

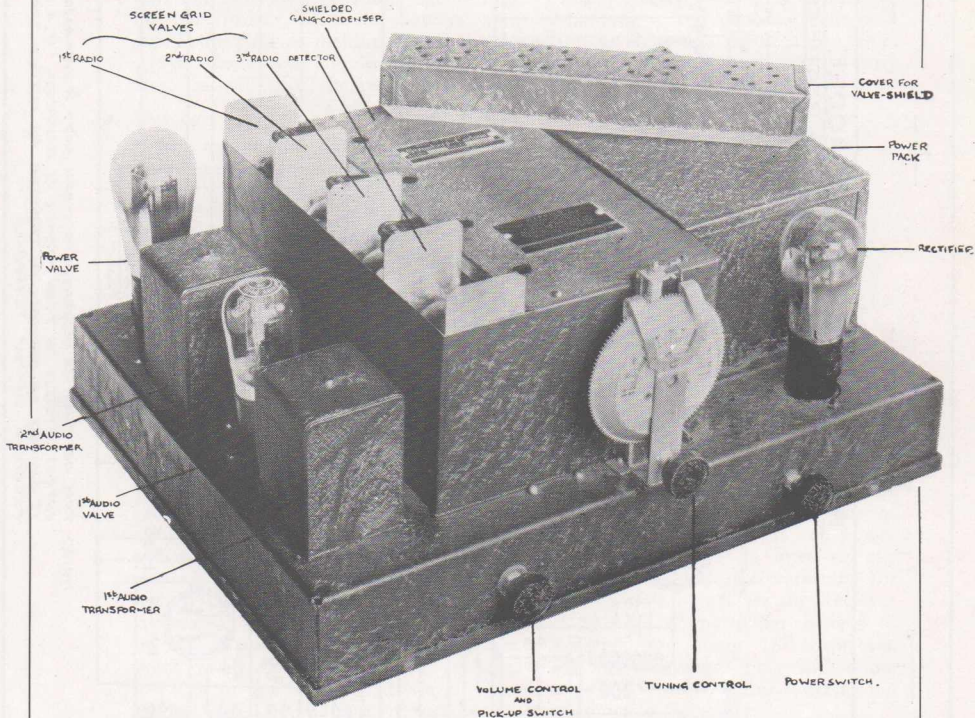

Chassis of 64 Model

This Service Bulletin is issued free of charge to all Authorised Stromberg-Carlson Distributors and Dealers. Applications for additional copies should be made direct to Stromberg-Carlson (Australasia) Ltd.

STROMBERG-CARLSON

SERVICE BULLETIN No. 64

Radio Receiver Model 64

ALL ELECTRIC, SCREEN-GRID, SIX VALVES AND RECTIFIER.

NOTE.—The manufacture of this model will cease as from May, 1931, and will be replaced by a new model 66, available in June, 1931.

This Receiver has been designed for maximum distance reception. It is built on our large type Chassis and is equipped with our brass straight line capacity type tuning Condensers.

Circuits.

Three stages of screen grid radio frequency, detector and two stages of audio.

General.

Instal in accordance with the instructions in the General Service Bulletin, taking care to check up the A.C. Line Voltage. The Receiver, except in special cases, is issued for use on 240 volt circuits. If the locality is a different voltage supply or is subject to high voltage fluctuations refer to the diagram and alter tapings accordingly. The Receiver should be connected up in accordance with the instructions accompanying it and particular attention should be paid to making the earth connection as short and direct as possible, whilst the aerial should be of such length (generally twenty-five to forty feet) as will give the most satisfactory results for selectivity.

Valves.

When testing the Receiver before issue to the customer the actual valves to be supplied with the Receiver should be used for the test.

Rectifier: Philips 1560 (Type 280).

1st, 2nd, 3rd R.F.: Philips F.242 (Type 224).

Detector and 1st Audio: Philips F.209A (Type 227).

Second Audio (Power): Philips F.203 (Type 245).

Dial Lamp.

2.5 volt circuit, but 3.8 or 4 volt lamp is utilized to ensure long service.

Speaker.

This model is designed for a Dynamic type Speaker with 7500 ohms D.C. field coil and lead wires are furnished to supply the field coil.

Operation.

The centre control knob is the station selector. The knob on the left is the volume control, which when turned right off automatically switches on the pick-up. The knob on the right is the tone control, although on some of the first models where the tone control was not fitted this knob is the power switch. Where the tone control is fitted the power switch is fitted on the side of the Cabinet. The volume control should be adjusted carefully for strong local signals, otherwise double peak tuning will occur. If the Receiver is located very near a Broadcast Station it will be of particular benefit to insert an ordinary "on-off" switch in the aerial lead about 18" from the point where it plugs into the aerial jack of the Receiver. This will allow the user to open the switch for use on strong local stations (thus working on an 18" aerial) and close it for distant stations when necessary.

TECHNICAL DESCRIPTION.

(To be read in conjunction with Drawing No. 10)

The power Transformer is of the layer wound type with tapped primary to suit the various line voltages from 225 to 275 volts.

The core is of laminated stallo and the windings are brought out by means of high grade insulated flexible wires and terminated on special strips to facilitate testing. As will be seen from the Drawing, separate 2.5 volt

STROMBERG-CARLSON

SERVICE BULLETIN No. 64 (Continued)

windings are provided for the A.C. valves and the power valve respectively, together with a 4.8 volt winding for the rectifier filament, and a 650 volt centre tapped winding for the rectifier plate.

The Filter Chokes are of the tapped type, wound on heavy laminated cores.

The Filter Condensers are in individual cans attached to a plate.

The Power Transformer, Filter Chokes and Filter Condensers are located beneath the same cover on top of the Chassis. Special By-pass Condensers, made up in groups of 4/ .3 m.f. per can, are located beneath the Chassis between the R.F. Valve sockets.

The Potential Divider is located beneath the Chassis, and care should be taken to see that the fine wire connections to the lugs are not damaged in any way when making tests.

The Tone Control fitted on the later models is not shown on the drawing, but consists of a .002 m.f. Condenser connected to the grid of the last valve, the other side of the Condenser being connected through a 500,000 ohm variable resistance to earth.

Tuning Coils are specially shielded in drawn copper cans, the latter being held to the Chassis by two threaded lugs and fixing nuts.

Tuning Condensers (4 gang) are carefully lined up before leaving the Factory, but, should they require re-lining due to rough transport, the trimmers are accessible through the holes in the top of the Condenser Can shield. Use a $\frac{3}{8}$ " fibre tube with hexagonal opening one end, line up on a weak signal between 250 and 350 metres wave length.

Pickup Switch. As will be seen from the drawing a cam on the Volume Control Spindle causes the Pickup lead to be connected to the grid. When radio is in use the cam disconnects this Pickup lead and connects it to earth.

Audio Transformers are our standard $3\frac{1}{2}$ to 1 heavy core type.

The Volume Control is a wire wound potentiometer 900 ohms controlling the grid bias on the radio frequency valves.

Voltages—1st, 2nd and 3rd R.F.

- A. 2.5 volt.
- B. 135/140 volt.
- C. Bias 1.75 to 9 volts (according to position of volume control).
- D. Screen 60/65 volts.

Detector—A. 2.45 volts.

B. 45 volts.

C. Nil.

1st Audio—A. 2.5 volts.

B. 200 volts.

C. 12 volts.

2nd Audio Power—A. 2.5 volts.

B. 220/240 volts.

C. 40/50 volts.

Faults.

Refer to General Service Bulletin, Pages 7-10, for general faults which may occur, but this Receiver is built with apparatus having a good factor of safety and little trouble should be experienced. As we frequently meet with cases where faulty or unreliable Rectifier Valves are used and so cause serious damage to the Power Unit particular care should be taken to see that the Valves we supply or recommend are used with the Receiver.

Replacement Parts.

When ordering replacement parts give full details indicating, wherever there is likely to be any doubt, on what part of the circuit they are required.

Stromberg-Carlson

STROMBERG-CARLSON
SERVICE BULLETIN, No. 355

Stromberg-Carlson Model 355 Superheterodyne

ALL-ELECTRIC, FOUR VALVES AND RECTIFIER

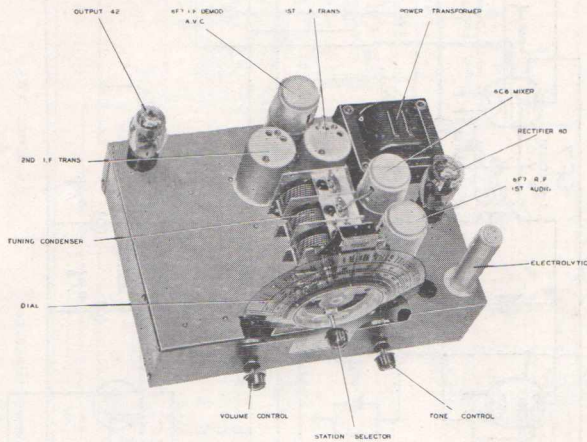

Chassis of 355 Model.

This Service Bulletin is issued free of charge to all authorised Stromberg-Carlson Dealers. Applications for additional copies should be made direct to the nearest Distributor.

Stromberg-Carlson (Australasia) Ltd. reserves the right to make changes in design details at any time without incurring any obligations to install same on radio receivers previously sold.

N.B.—BEFORE LEAVING A STROMBERG-CARLSON RADIO RECEIVER IN A CUSTOMER'S HOME, SEE THAT EVERYBODY WHO IS LIKELY TO HANDLE THE RECEIVER FULLY UNDERSTANDS ITS OPERATION. BY SO DOING MANY UNNECESSARY SERVICE CALLS WILL BE AVOIDED.

Stromberg-Carlson Model 355 Superheterodyne

ALL-ELECTRIC, FOUR VALVES AND RECTIFIER

1. GENERAL DESCRIPTION OF RECEIVER:

This Receiver is a 5-valve superheterodyne, employing the famous duplex circuit developed in the Stromberg-Carlson (Australasia) Ltd. laboratories.

By the use of this circuit it is possible to achieve results comparable with those obtained from receivers using at least one additional valve. The outstanding features of this Receiver are its excellent reproduction, high sensitivity and extremely low noise level. The delayed automatic volume control is most efficient, and should prove an excellent feature for country users.

2. INSTALLATION INSTRUCTIONS:

(a) Aerial.

The sensitivity of this model is such that for broadcasting reception a well-insulated wire about 20 or 30 feet in length, placed along the picture moulding in a room, or beneath the carpet, will prove satisfactory. Care should be taken to place all such indoor aerials as far away as possible from electric light or power conduits, and, in particular, clear of all unshielded flexible leads, since these latter are prolific radiators of undesirable electrical impulses.

An outdoor aerial is the most efficient, and is strongly recommended, especially for long-distance daylight reception on the broadcast band. The length of this aerial should be from 30 to 50 feet. In noisy areas (due to electrical interference) the aerial should be erected as far as possible from and at right-angles to any electric power or light mains. As a further precaution against undesirable pick-up, the lead-in should be a special shielded type as employed in the "Stromberg-Carlson Aerial Noise Eliminator Kit." Details of this type of aerial may be had on application to Stromberg-Carlson (Australasia), Limited.

(b) Earth.

The chassis should be connected to earth by means of an insulated wire attached to a water pipe by an approved clamp. It is preferable to connect the earth lead to the last section of the pipe where it enters the ground, thus avoiding the high resistance contacts at the joints. Should a water system not be available, an efficient earth may be obtained by driving a metal pipe or burying about four square feet of metal sheeting in moist earth; the connection to the metal should preferably be soldered.

(c) Voltage Adjustment Panel.

Before leaving the factory the voltage switch is set to the 240-volt setting. If the line voltage differs from this, the switch should be set to the position nearest to, but not less than the measured line voltage in the locality. The voltage tappings for 200, 220, 240, 265 volts are designated on the back of the chassis. The adjustment is readily carried out by means of a screwdriver on removing the danger plate.

When making any adjustment, see that the power plug is completely removed from the socket of the supply source.

SERVICE BULLETIN, No. 355 (Continued)

Page 4

(d) Trimmer Adjustments.

The trimmer capacitors on the variable condenser, coil assembly, and the trimmer capacitors on the Intermediate Frequency Transformers (tuned to 450 k.c.) are adjusted and sealed at the factory at the time of calibration. These adjustments should on no account be touched or seals broken unless a specially calibrated oscillator and indicating instrument are available, whereby such adjustments can be successfully carried out.

In any repairs or adjustments the above remarks in regard to the coil assembly and intermediate transformer should be carefully noted.

3. OPERATION.

(a) Automatic Volume Control.

This Model is so designed that the signal voltages fed to the audio system, tend to adjust themselves to a constant level. This signal level is manually controlled and should be adjusted to the desired volume on a station of moderate or high power. The automatic feature will then tend to maintain this volume at a constant level on different signals of wide variations in intensity.

The effects of fading being thus reduced to an absolute minimum, constant attention to the volume control is obviated, especially on the reception of weak and distant stations.

(c) Tone Control.

The right-hand knob is the Tone Control. For normal or "brilliant" reception turn Tone Control to right. Where the background of noise is objectionable (as sometimes occurs on long-distance reception) turn the Tone Control to the left.

For the reception of local or strong interstate stations the Tone Control should be at the "brilliant" position in order that the full range of musical frequencies and overtones may be enjoyed.

4. VALVES:

All Receivers leaving the factory are equipped with valves inserted into the sockets. If for any reason it becomes necessary to remove the valves, care should be taken to see that each one is replaced in the socket from which it was taken. The photograph of the chassis on page 1 shows the type and function of the valves and their exact location.

Function of Valve.	Type of Valve.
R.F., 1st Audio	6F7
Autodyne	6C6
I.F.A.V.C. Det.	6F7
Output	42
Rectifier	80

5. SPEAKER:

The speaker in this Model is the Dynamic or moving coil type, and is matched to the output valve. The field coil being used at the date of issue of this Bulletin has a resistance of 1000 ohms. The speaker terminates in a four-pin plug at the Receiver chassis.

THIS PLUG SHOULD NOT BE REMOVED WHILE THE CURRENT IS TURNED ON,

SERVICE BULLETIN, No. 355 (Continued)

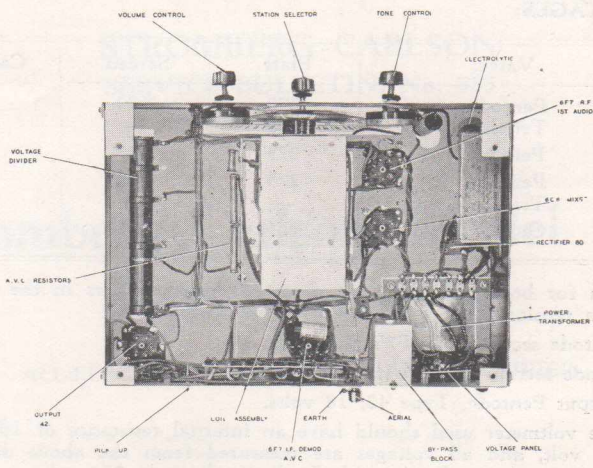

6. PICK-UP JACKS:

Provision is made at the back of the Chassis for the attachment of a Phonograph Pick-up. To operate the pick-up, remove the metal bar between the centre and bottom jacks, and connect the leads from the pick-up to the centre and top jacks, as illustrated.

The metal bar must be replaced when the Receiver is again required for radio operation.

The Volume Control on the Receiver may be used to regulate the audio output from the pick-up.

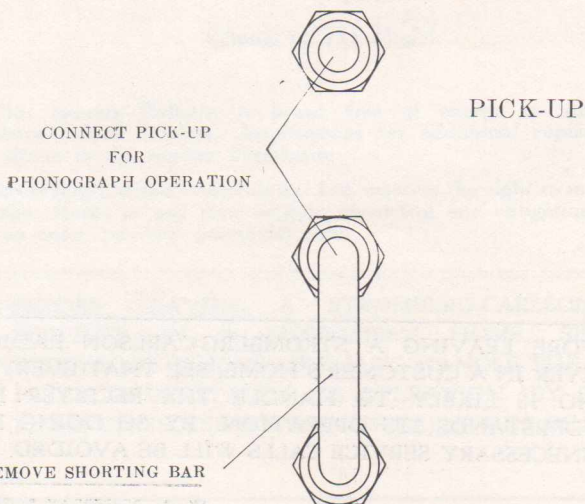

SERVICE BULLETIN, No. 355 (Continued)

Page 6

7. VOLTAGES:

	Valve.	Plate.	Screen.	Cathode
6F7	Pentode	275	100	0
	Triode	100	—	
6C6	Pentode	275	100	7
6F7	Pentode	275	100	0
	Triode	—	—	—
42	Output	265	275	0

Bias for both 6F7's and 42 obtained from resistors in the negative high tension lead.

Pentode sections of 6F7's, 1.5 volts.

Triode section of 6F7 (in R.F. stage), 18 volts.

Output Pentode, Type 42, 18 volts.

The voltmeter used should have an internal resistance of 1000 ohms per volt, and all voltages are measured from the above designated valve prongs to chassis, with the line voltage at 240 volts.

8. COMPONENTS:

The numbers refer to the position of the component on the assembly panel.

- | | |
|-----------------------|---------------------|
| 1. Blank. | 6. 200,000 ohms. |
| 2. 0.0001 microfarad. | 7. .02 microfarad. |
| 3. 1 megohm. | 8. 0.2 megohm. |
| 4. .02 microfarad. | 9. .004 microfarad. |
| 5. Blank. | |

Capacitor Block: 4 red leads, 0.25 microfarad.
1 yellow lead, 0.5 microfarad.

N.B.—BEFORE LEAVING A STROMBERG-CARLSON RADIO RECEIVER IN A CUSTOMER'S HOME, SEE THAT EVERYBODY WHO IS LIKELY TO HANDLE THE RECEIVER FULLY UNDERSTANDS ITS OPERATION. BY SO DOING MANY UNNECESSARY SERVICE CALLS WILL BE AVOIDED.

STROMBERG - CARLSON

NOTES ON 355A REVISED CIRCUIT:

Valve.	Voltages.		
	Plate.	Screen.	Cathode.
6F7 Pentode	275	100	0
Triode	100	—	—
6A7 Pentode	275	100	0
Triode	180	—	—
6F7 Pentode	275	100	24 volt
Triode	—	—	—
42 Output	265	275	0

Bias for 6A7, 6F7 and 42 obtained from resistors in the negative high tension lead.

Pentode section 6F7, 6A7: 1.5 volts.

Triode section of 6F7 (in R.F. stage): 18 volts.

Output Pentode, Type 42: 18 volts.

The voltmeter used should have an internal resistance of 1000 ohms per volt, and all voltages are measured from the above designated Valve prongs and Chassis, with the line voltage at 240 volts.

Components.

The numbers refer to the position of the component on the assembly panel:—

- | | |
|-----------------------|--------------------|
| 1. 300 ohms. | 6. .02 microfarad. |
| 2. 4000 ohms. | 7. 50,000 ohms. |
| 3. .00025 microfarad. | 8. 200,000 ohms. |
| 4. 1 megohm. | 9. .04 microfarad. |
| 5. 100,000 ohms. | 10. 500,000 ohms. |

Capacitor Block:—4 red leads, 0.25 microfarad.
1 yellow lead, 0.5 microfarad.

The intermediate frequency on the Model 355A is 175 K.C.

Stromberg-Carlson

STROMBERG-CARLSON
SERVICE BULLETIN No. 405

Stromberg-Carlson Model 405

FOUR-VALVE, BATTERY-OPERATED

Superheterodyne

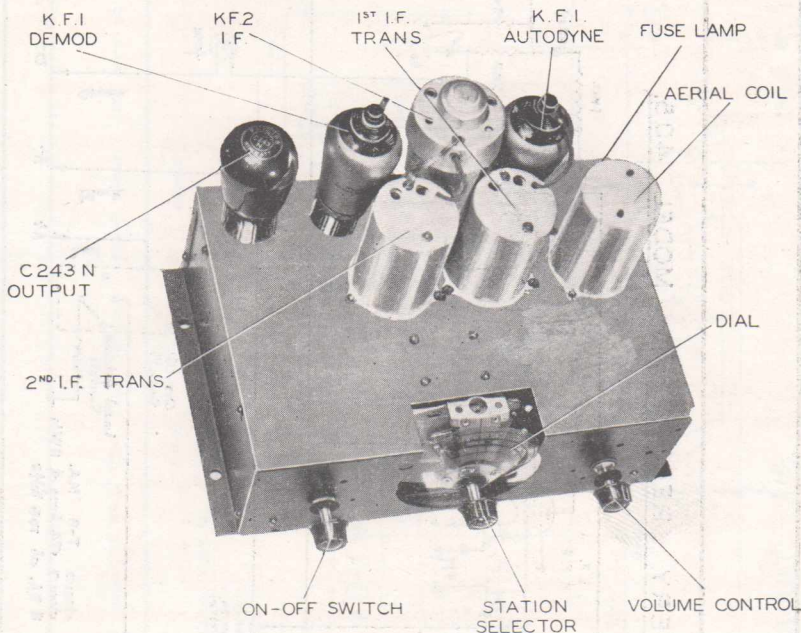

Chassis of Model 405.

This Service Bulletin is issued free of charge to all authorised Stromberg-Carlson Dealers. Applications for additional copies should be made direct to the nearest Distributor.

Stromberg-Carlson (Australasia) Ltd. reserves the right to make changes in design details at any time without incurring any obligations to install same on radio receivers previously sold.

N.B.—BEFORE LEAVING A STROMBERG-CARLSON RADIO RECEIVER IN A CUSTOMER'S HOME, SEE THAT EVERYBODY WHO IS LIKELY TO HANDLE THE RECEIVER FULLY UNDERSTANDS ITS OPERATION. BY SO DOING MANY UNNECESSARY SERVICE CALLS WILL BE AVOIDED.

SERVICE BULLETIN, No. 405 (Continued)

Stromberg-Carlson Model 405

FOUR-VALVE, BATTERY-OPERATED

Superheterodyne**1. GENERAL DESCRIPTION OF RECEIVER:**

This receiver is a 4-valve battery-operated superheterodyne, designed for use on the broadcast band from 200 to 550 metres. The receiver has been designed to obtain the maximum in sensitivity, selectivity, and quality consistent with a minimum consumption of both "A" and "B" batteries.

The tuning adjustment on the gang capacitor (variable tuning condenser), and the trimmer capacitors on the Intermediate Frequency Transformers (tuned to 465 K.C.) are adjusted and sealed at the factory at the time of calibration.

These adjustments should on no account be touched, or the seals broken, unless a specially calibrated oscillator and indicating instrument are at hand whereby such adjustments can be successfully carried out. In any repairs or adjustments the above remarks in regard to the gang capacitor and intermediate transformers should be carefully noted.

2. BATTERIES:

(i.) "A" Battery—This is a 2-volt storage battery or equivalent 2-volt battery, having a (recommended) capacity of at least 80 ampere-hours. The "A" battery drain is 0.74 ampere.

(ii.) "B" Batteries—These comprise three heavy-duty 45-volt batteries. The "B" Battery consumption varies with the adjustment of the volume control, averaging about 8 M.A.

To connect the battery leads correctly, reference should be made to the designation tabs on the leads, and to the colour code as shown on the circuit diagram on Page 2.

The "A" battery and the three "B" batteries may be placed on the lower shelf of the speaker compartment of the cabinet.

3. INSTALLATION INSTRUCTIONS:**(a) Aerial.**

The sensitivity of this model is such that an aerial placed along the picture moulding in a room, or beneath the carpet, will prove satisfactory. Care should be taken to place all such indoor aerials as far away as possible from electric light or power conduits, and, in particular, clear of all unshielded flexible leads, since these latter are prolific radiators of undesirable electrical impulses.

An outdoor aerial is the most efficient. The length of this aerial should be from 32 to 50 feet. In noisy areas (due to electrical interference) the aerial should be erected as far as possible from, and at right angles to, any electric power or light mains.

(b) Earth.

The chassis should be connected to earth by means of an insulated wire attached to a water pipe by an approved clamp. It is preferable to connect the earth lead to the last section of the pipe where it enters the ground, thus avoiding the high resistance contacts at the joints. Should a water system not be available, an efficient earth may be obtained by driving a metal pipe or burying about four square feet of metal sheeting in moist earth; the connection to the metal should preferably be soldered.

SERVICE BULLETIN, No. 405 (Continued)

4. OPERATION:

There are three positions on the "on-off" switch: fully to the left, off; centre position, long-distance reception; right, local reception. The local reception position should be used whenever a powerful local station is being received.

In this model the left-hand knob is the "on-off" switch; the right-hand knob is the volume control; and the centre knob is the tuning control. Improper tuning will affect the quality of reproduction. Care should be taken to keep the volume control well down, then adjust the tuning control to the point of maximum undistorted signal, thereafter adjusting the volume to the desired level. Judicious use of the volume and tuning controls in the Model 405 will assist in the economy of battery consumption.

5. VOLTAGES:

Valve	Function	Plate	Screen	Bias.
KF1	Det. Osc.	127	127	—
KF2	I.F.	127	127	—8 to —.5
KF1	Second Detector	—	—	—
C243N	Output Pentode	127	127	—

7. COMPONENTS:

The following list of components are given to facilitate the servicing of the receiver, and as a guide to replacement.

The numbers refer to position of the components on the assembly panel.

- | | | |
|-------------------|----------------------|----------------------|
| 1. 10 ohms. | 6. .5 microfarad. | 11. 100,000 ohms. |
| 2. .1 microfarad. | 7. .1 microfarad. | 12. .02 microfarad. |
| 3. 150 ohms. | 8. 100,000 ohms. | 13. 500,000 ohms. |
| 4. 25 microfarad. | 9. .1 microfarad. | 14. .002 microfarad. |
| 5. — | 10. .001 microfarad. | |
- 100,000 ohms, half-watt between 11 and 12, side "b."

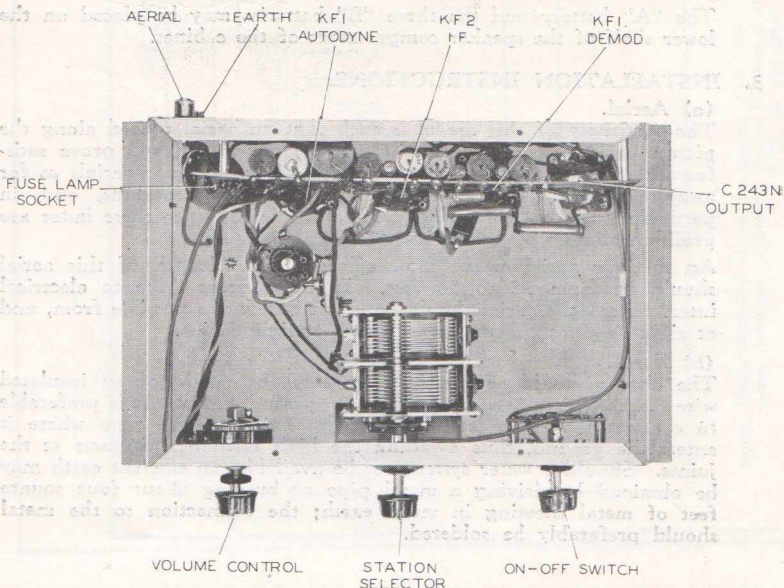

CHANGES

DRAWN 223
 EXAMINED
 APPROVED *[Signature]* DIRECTOR
 DATE 5 6 35

High tension current drain 7-8 MA at 135V. Low tension current drain .62 amp at 2 volts.

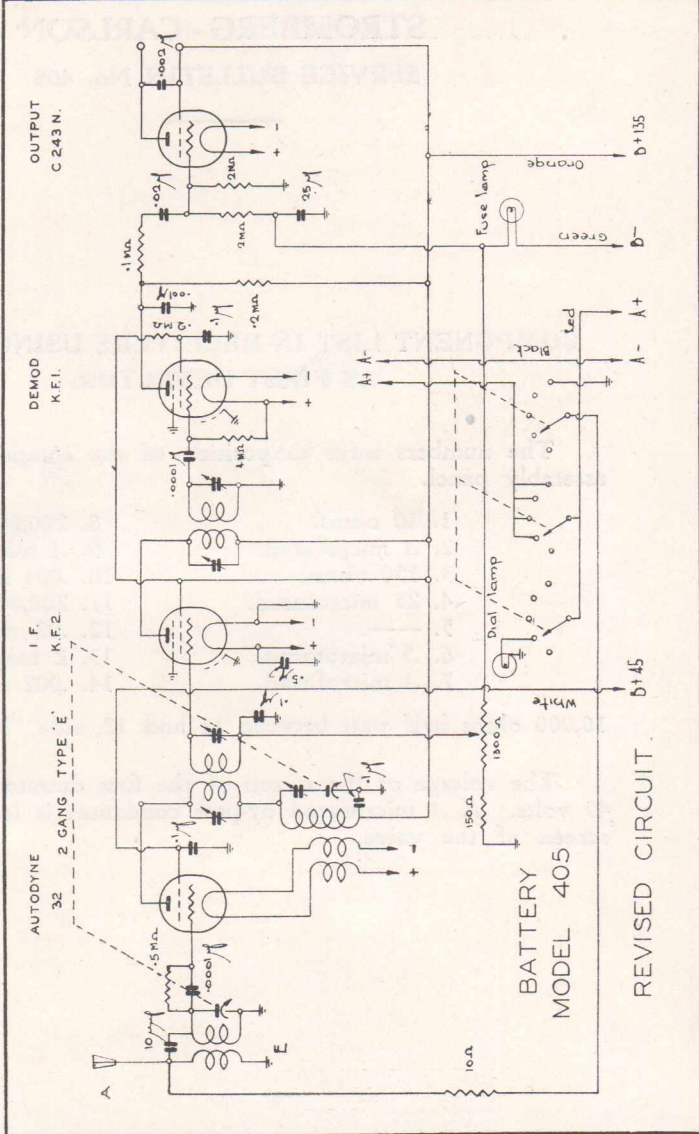

BATTERY
 MODEL 405

REVISED CIRCUIT.

STROMBERG-CARLSON

STROMBERG - CARLSON SERVICE BULLETIN No. 405

COMPONENT LIST IN RECEIVERS USING TYPE 32 AS FIRST DETECTOR.

The numbers refer to position of the components on the assembly panel.

- | | |
|-------------------|----------------------|
| 1. 10 ohms. | 8. 200,000 ohms. |
| 2. .1 microfarad. | 9. .1 microfarad. |
| 3. 150 ohms. | 10. .001 microfarad. |
| 4. 25 microfarad. | 11. 200,000 ohms. |
| 5. ———. | 12. .02 microfarad. |
| 6. .5 microfarad. | 13. 2 megohms. |
| 7. .1 microfarad. | 14. .002 microfarad. |

10,000 ohms half watt between 11 and 12, side "b."

The voltage of the screen of the first detector, type 32, is 45 volts. A .1 microfarad by-pass condenser is located on the screen of the valve.

Stromberg-Carlson

STROMBERG-CARLSON
SERVICE BULLETIN No. 406

Stromberg-Carlson Model 406

FOUR-VALVE, BATTERY-OPERATED

Superheterodyne

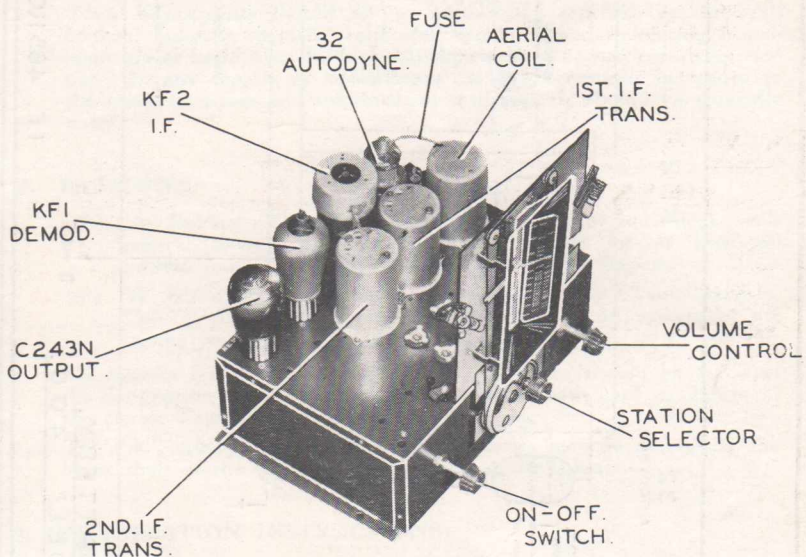

Chassis of Model 406

This Service Bulletin is issued free of charge to all authorised Stromberg-Carlson Dealers. Applications for additional copies should be made direct to the nearest Distributor.

Stromberg-Carlson (Australasia) Ltd. reserves the right to make changes in design details at any time without incurring any obligations to install same on radio receivers previously sold.

STROMBERG - CARLSON (AUSTRALASIA) LIMITED
 SYDNEY AUSTRALIA

DRAWING No 773

CHANGES

DRAWN *Shel*
 EXAMINED *Alan*
 APPROVED MGN, DIRECTOR
 DATE 13-1-36

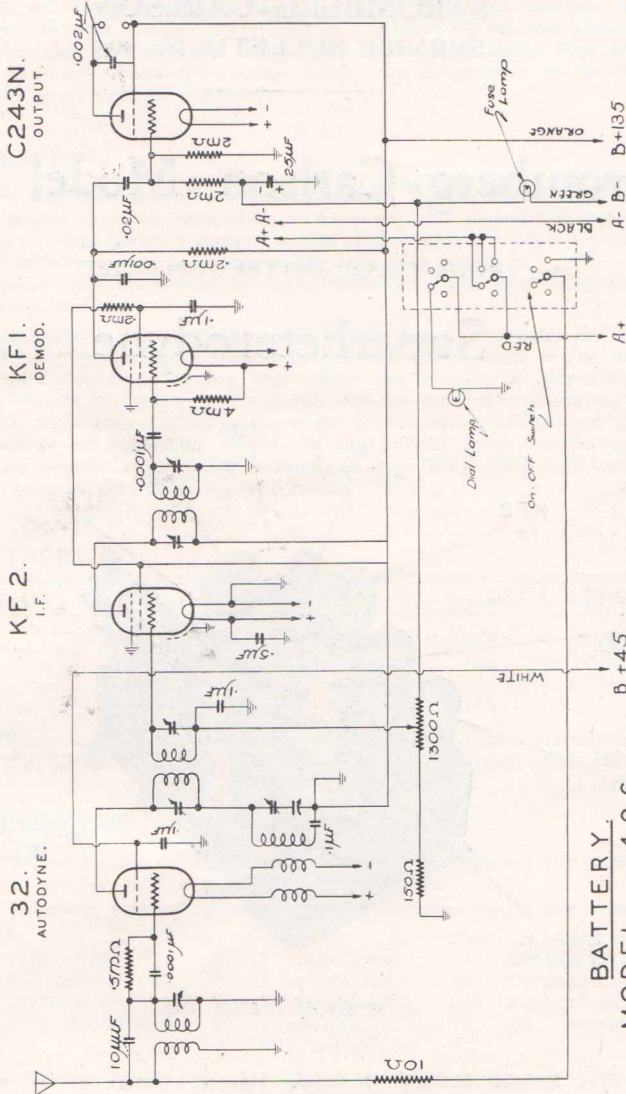

I.F. 465 KC.

BATTERY MODEL 406.

SERVICE BULLETIN No. 406 (Continued)

Stromberg-Carlson Model 406

FOUR-VALVE, BATTERY-OPERATED

Superheterodyne

1. GENERAL DESCRIPTION OF RECEIVER:

This receiver is a 4-valve battery-operated superheterodyne, designed for use on the broadcast band from 200 to 550 metres. The receiver has been designed to obtain the maximum in sensitivity, selectivity, and quality consistent with a minimum consumption of both "A" and "B" batteries.

The tuning adjustment on the gang capacitor (variable tuning condenser), and the trimmer capacitors on the Intermediate Frequency Transformers (tuned to 465 K.C.) are adjusted and sealed at the factory at the time of calibration.

These adjustments should on no account be touched, or the seals broken, unless a specially calibrated oscillator and indicating instrument are at hand whereby such adjustments can be successfully carried out. In any repairs or adjustments the above remarks in regard to the gang capacitor and intermediate transformers should be carefully noted.

2. BATTERIES:

- (i.) "A" Battery—This is a 2-volt storage battery or equivalent 2-volt battery, having a (recommended) capacity of at least .80 ampere-hours. The "A" battery drain is 0.62 ampere.
- (ii.) "B" Batteries—These comprise three heavy-duty 45-volt batteries. The "B" Battery consumption varies with the adjustment of the volume control, averaging about 8 M.A.

To connect the battery leads correctly, reference should be made to the designation tabs on the leads, and to the colour code as shown on the circuit diagram on Page 2.

The "A" battery and the three "B" batteries may be placed on the lower shelf of the speaker compartment of the cabinet.

3. INSTALLATION INSTRUCTIONS:

(a) Aerial.

The sensitivity of this model is such that an aerial placed along the picture moulding in a room, or beneath the carpet, will prove satisfactory. Care should be taken to place all such indoor aerials as far away as possible from electric light or power conduits, and, in particular, clear of all unshielded flexible leads, since these latter are prolific radiators of undesirable electrical impulses.

An outdoor aerial is the most efficient. The length of this aerial should be from 30 to 50 feet. In noisy areas (due to electrical interference) the aerial should be erected as far as possible from, and at right angles to, any electric power or light mains.

SERVICE BULLETIN No. 406 (Continued)

(b) Earth.

The chassis should be connected to earth by means of an insulated wire attached to a water pipe by an approved clamp. It is preferable to connect the earth lead to the last section of the pipe where it enters the ground, thus avoiding the high resistance contacts at the joints. Should a water system not be available, an efficient earth may be obtained by driving a metal pipe or burying about four square feet of metal sheeting in moist earth; the connection to the metal should preferably be soldered.

4. OPERATION:

There are four positions on the "on-off" switch: Fully to the left, off; second position, long-distance reception and dial lamps on; third position, long-distance reception and dial lamps off; fourth position, fully to the right, local reception and dial lamps off. The local reception position should be used whenever a powerful local station is being received.

In this model the left-hand knob is the "on-off" switch; the right-hand knob is the volume control; and the centre knob is the tuning control. Improper tuning will affect the quality of reproduction. Care should be taken to keep the volume control well down, then adjust the tuning control to the point of maximum undistorted signal, thereafter adjusting the volume to the desired level. Judicious use of the volume and tuning controls in the Model 406 will assist in the economy of battery consumption.

5. VOLTAGES:

Valve	Function	Plate	Screen	Bias.
32	Det. Osc.	125	45	—
KF2	I.F.	125	125	- 10 to - .5
KF1	Second Detector	—	—	—
C243N	Output Pentode	125	125	—

KF1 screen series fed from B max. through 200,000 ohms.

7. COMPONENTS:

The following list of components is given to facilitate the servicing of the receiver, and as a guide to replacement.

The numbers refer to position of the components on the assembly panel.

- | | | |
|-------------------|----------------------|----------------------|
| 1. 10 ohms. | 6. .5 microfarad. | 11. 200,000 ohms. |
| 2. .1 microfarad. | 7. .1 microfarad. | 12. .02 microfarad. |
| 3. 150 ohms. | 8. 200,000 ohms. | 13. 2 megohms. |
| 4. 25 microfarad. | 9. .1 microfarad. | 14. .002 microfarad. |
| 5. — | 10. .001 microfarad. | |

100,000 ohms, half-watt between 11 and 12, side "b."

N.B.—BEFORE LEAVING A STROMBERG-CARLSON RADIO RECEIVER IN A CUSTOMER'S HOME, SEE THAT EVERYBODY WHO IS LIKELY TO HANDLE THE RECEIVER FULLY UNDERSTANDS ITS OPERATION. BY SO DOING MANY

Amplora Radio Receiver Model 492

All Electric 3 Valves and Rectifier

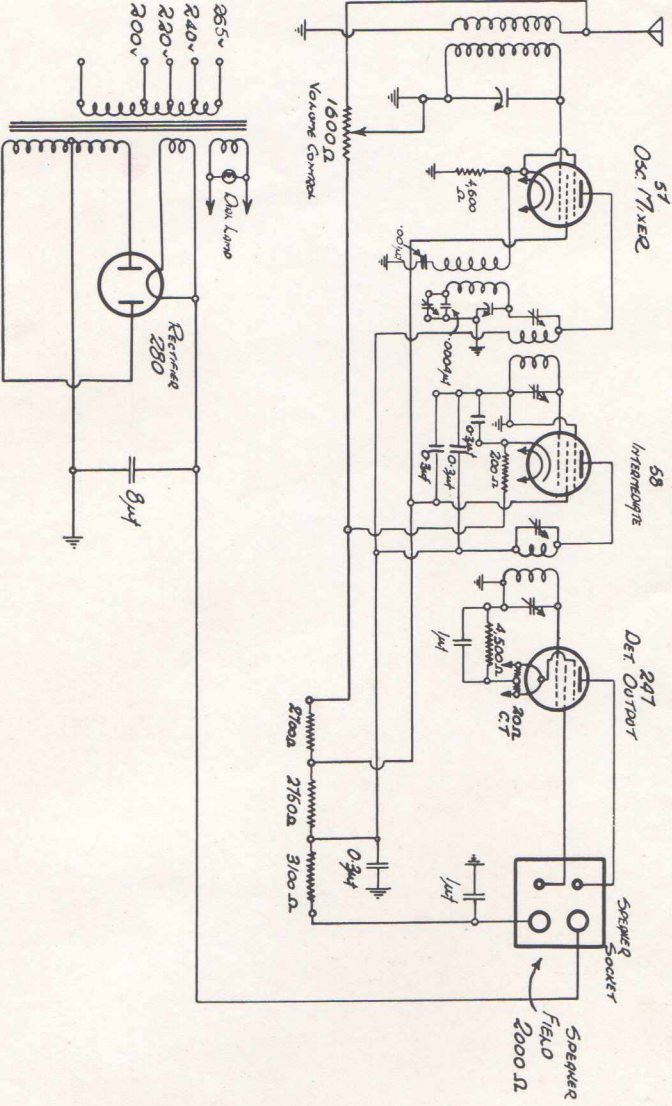

CHANGES

STROMBERG CARLSON (AUSTRALASIA) LIMITED
SYDNEY AUSTRALIA

Drawn J.W.S.
Examined S.M.A.
Approved [Signature]
Date 17-11-32

Drawings No 2

Stromberg-Carlson

Page 1

SERVICE BULLETIN No. 504

Radio Receiver Model 504

BATTERY-OPERATED, SUPERHETERODYNE, FIVE VALVES

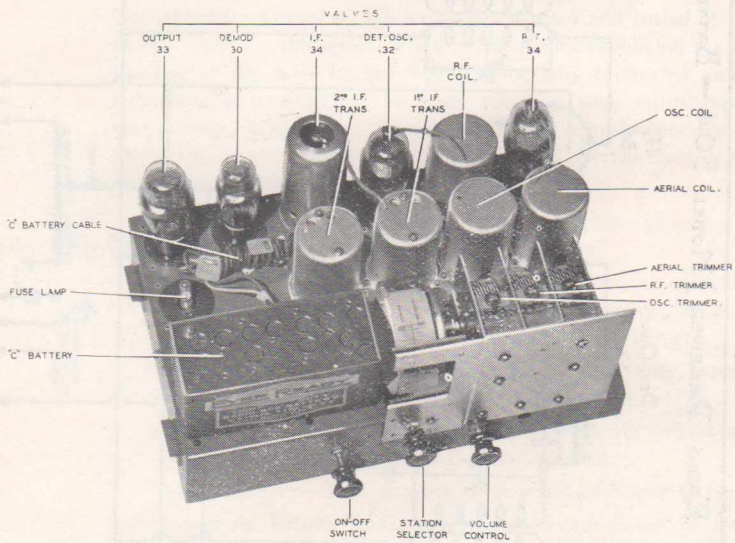

Chassis of Model 504

This Service Bulletin is issued free of charge to all authorised Stromberg-Carlson and Audiola Dealers. Applications for additional copies should be made direct to the nearest Distributor.

Stromberg-Carlson (Australasia) Ltd. reserves the right to make changes in design details at any time, without incurring any obligations to install same on Radio Receivers previously sold.

RADIO RECEIVER MODEL 504 - BATTERY

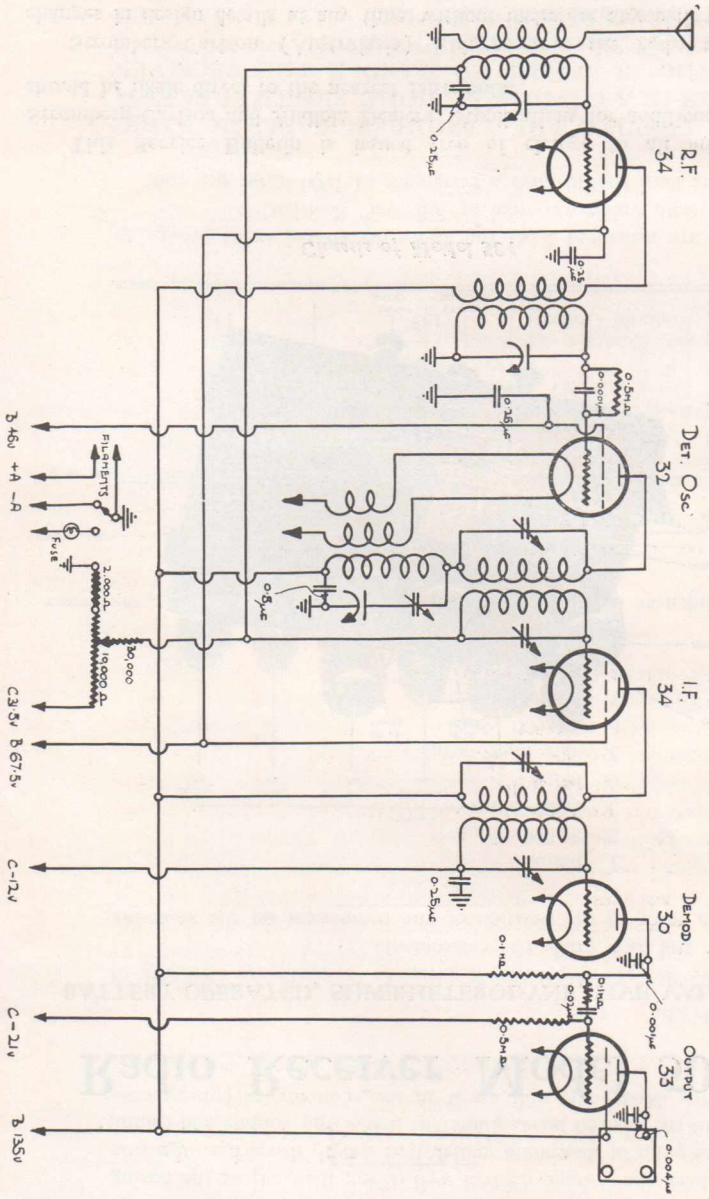

<p style="text-align: center;">STROMBERG-CARLSON (AUSTRALASIA) LIMITED SYDNEY AUSTRALIA</p>	<p style="text-align: center;">CHANGES</p>
<p>Dwg No 2167</p> <p>Drawn <i>J.D.S.</i></p> <p>Examined <i>S.P.H.</i></p> <p>Approved <i>M.H. Director</i></p> <p>Date 12-3-33</p>	<p>2.45V (+A -A)</p> <p>2.45V (+B -B)</p> <p>2.45V (+C -C)</p> <p>2.15V</p>

SERVICE BULLETIN No. 504 (Continued)

Radio Receiver Model 504

BATTERY-OPERATED, SUPERHETERODYNE, FIVE VALVES

1. GENERAL DESCRIPTION OF RECEIVER.

The Model 504 Battery-operated Receiver has been designed with a view to obtaining the maximum in sensitivity, selectivity and quality, consistent with a minimum consumption of both the A and B batteries. The tuning adjustments on the gang capacitor (variable tuning condenser) and the trimmer capacitors on the Intermediate Frequency Transformers (tuned to 175 k.c.) are adjusted and sealed at the factory at the time of calibration. These adjustments should on no account be touched or the seals broken unless a specially calibrated oscillator and indicating instrument are to hand whereby such adjustments can be successfully carried out. In any repairs or adjustments the above remarks in regard to the gang capacitor and intermediate transformers should be carefully noted.

2. BATTERIES.

(i.) *A Battery*—This is a 2-volt storage battery or equivalent 2-volt battery, having a (recommended) capacity of at least 80 ampere-hours. The A Battery drain is 0.5 ampere.

(ii.) *B Batteries*—These comprise three heavy duty, super, or (recommended) "Superdyne" 45-volt batteries.

The B Battery consumption varies with the adjustment of the volume control, averaging about 12 M.A.

(iii.) *C Battery*—This consists of a small 31.5-volt C type battery. To connect the battery leads correctly, reference should be made to the designation tabs on the leads, and to the colour code as shown on the circuit diagram on page 2.

The A battery and the three B batteries may be placed on the lower shelf of the speaker compartment of the cabinet. The C battery rests on the chassis as shown in the instruction card.

3. OPERATION.

The more sensitive and selective the receiver is, the greater the care to be taken in the operation and tuning to obtain the best results. In this model the left-hand knob is the "on-off" switch, the right-hand knob is the volume control, and the centre knob is the tuning control.

STROMBERG - CARLSON

Page 4

SERVICE BULLETIN No. 504 (Continued)

Improper tuning will affect the quality of reproduction. Care should be taken to keep the volume control well down, then adjust the tuning control to the point of maximum undistorted signal, thereafter adjusting the volume to the desired level. Judicious use of the volume and tuning controls in the Model 504 will assist in the economy of battery consumption.

4. COMPONENTS.

The following list of components is given to facilitate the servicing of the Receiver and as a guide to replacements.

The numbers refer to the position of the component on the assembly panel.

1. blank
2. 30,000 ohms
3. 2,000 ohms
4. blank
5. .001 microfarad
6. 100,000 ohms
7. 100,000 ohms
8. .02 microfarad
9. .5 microfarad

Condenser Block: 4 Red Leads, .25 microfarad
1 Yellow Lead, .5 microfarad

5. VOLTAGES.

Valve	Function	Screen Volts	Plate Volts
234	Radio Frequency	67.5	135
232	Det.-Oscillator	45	135
234	I.F.	67.5	135
230	2nd Detector	—	70
233	Pentode Output	135	135

All voltages are measured from the above designated valve prongs to chassis base, with volume control at full "on" position.

The voltmeter used should have a resistance of 1000 ohms per volt.

N.B.—BEFORE LEAVING THE STROMBERG-CARLSON RADIO RECEIVER IN A CUSTOMER'S HOME, SEE THAT EVERYBODY WHO IS LIKELY TO HANDLE THE RECEIVER FULLY UNDERSTANDS ITS OPERATION. BY SO DOING MANY UNNECESSARY SERVICE CALLS MAY BE AVOIDED.

Stromberg-Carlson

STROMBERG-CARLSON
SERVICE BULLETIN No. 504-M

Radio Receiver Model 504-M

FIVE VALVE BATTERY-OPERATED SUPERHETERODYNE

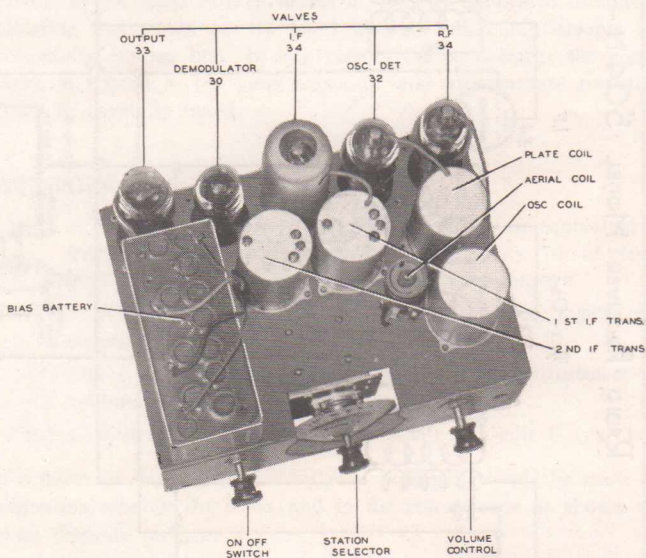

Chassis of Model 504-M

This Service Bulletin is issued free of charge to all authorised Stromberg-Carlson Dealers. Applications for additional copies should be made direct to the nearest Distributor.

Stromberg-Carlson (Australasia) Ltd. reserves the right to make changes in design details at any time without incurring any obligations to install same on radio receivers previously sold.

STROMBERG - CARLSON (AUSTRALASIA) LIMITED
 SYDNEY AUSTRALASIA

DRAWING No 234

CHANGES

DESIGN I.W.S.
 EXAMINED C.M.
 APPROVED
 MAIN DIRECTOR
 DATE 7-6-34

RADIO RECEIVER MODEL 504M - BATTERY

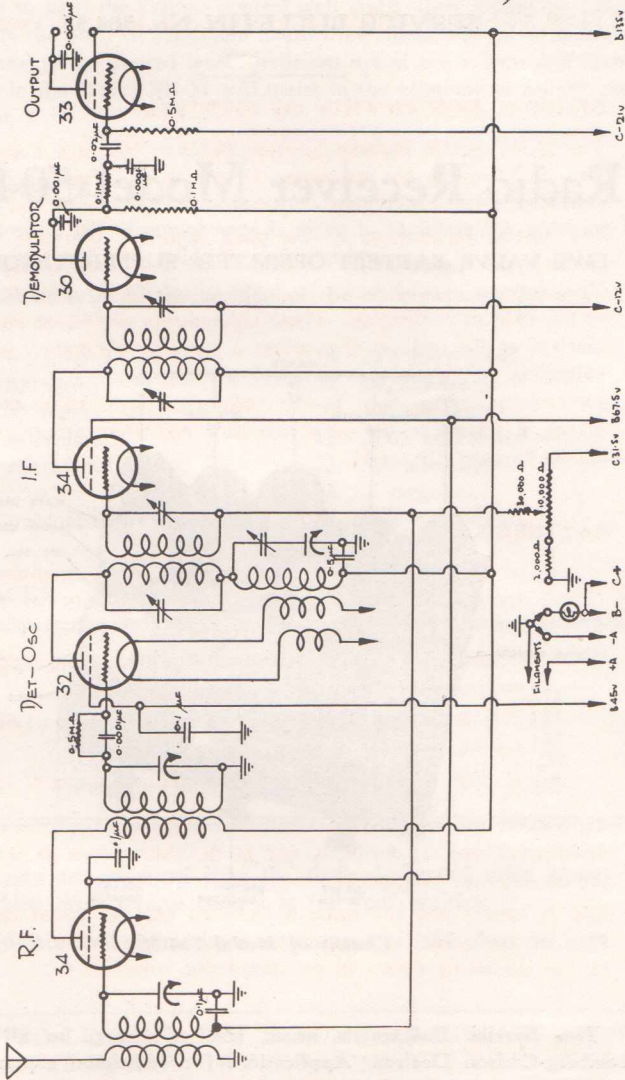

SERVICE BULLETIN No. 504-M (*Continued*)

Page 3

Radio Receiver Model 504-M**FIVE VALVE BATTERY-OPERATED, SUPERHETERODYNE****1. GENERAL DESCRIPTION OF RECEIVER.**

The Model 504-M Battery-operated Receiver has been designed with a view to obtaining the maximum in sensitivity, selectivity and quality, consistent with a minimum consumption of both the A and B batteries.

The tuning adjustments on the gang capacitor (variable tuning condenser) and the trimmer capacitors on the Intermediate Frequency Transformers (tuned to 175 k.c.) are adjusted and sealed at the factory at the time of calibration. These adjustments should on no account be touched or the seals broken unless a specially calibrated oscillator and indicating instrument are to hand whereby such adjustments can be successfully carried out. In any repairs or adjustments the above remarks in regard to the gang capacitor and intermediate transformers should be carefully noted.

2. BATTERIES.

(i.) *A Battery*—This is a 2-volt storage battery or equivalent 2-volt battery, having a (recommended) capacity of at least 80 ampere-hours. The A Battery drain is 0.5 ampere.

(ii.) *B Batteries*—These comprise three heavy duty, super, or (recommended) "Superdyne" 45-volt batteries.

The B Battery consumption varies with the adjustment of the volume control, averaging about 12 M.A.

(iii.) *C Battery*—This consists of a small 31.5-volt C type battery.

To connect the battery leads correctly, reference should be made to the designation tabs on the leads, and to the colour code as shown on the circuit diagram on page 2.

The A battery and the three B batteries may be placed on the lower shelf of the speaker compartment of the cabinet. The C battery rests on the chassis as shown in the instruction card.

3. OPERATION.

The more sensitive and selective the receiver is, the greater the care to be taken in the operation and tuning to obtain the best results. In this model the left-hand knob is the "on-off" switch, the right-hand knob is the volume control, and the centre knob is the tuning control.

SERVICE BULLETIN No. 504-M (Continued)

Page 4

Improper tuning will affect the quality of reproduction. Care should be taken to keep the volume control well down, then adjust the tuning control to the point of maximum undistorted signal, thereafter adjusting the volume to the desired level. Judicious use of the volume and tuning controls in the Model 504-M will assist in the economy of battery consumption.

4. COMPONENTS.

The following list of components is given to facilitate the servicing of the Receiver and as a guide to replacements.

The numbers refer to the position of the component on the assembly panel.

- | | |
|-------------------|-----------------------|
| 1. .1 microfarad. | 8. .001 microfarad. |
| 2. 30,000 ohms. | 9. 100,000 ohms. |
| 3. 1,000 ohms. | 10. 100,000 ohms. |
| 4. .1 microfarad. | 11. .0001 microfarad. |
| 5. .1 microfarad. | 12. .02 microfarad. |
| 6. | 13. .5 megohm. |
| 7. .5 microfarad. | 14. .004 microfarad. |

5. VOLTAGES.

Valve	Function	Screen Volts	Plate Volts
234	Radio Frequency	67.5	135
232	Det.-Oscillator	45	135
234	I.F.	67.5	135
230	2nd Detector	—	70
233	Pentode Output	135	135

All voltages are measured from the above designated valve prongs to chassis base, with volume control at full "on" position.

The voltmeter used should have a resistance of 1000 ohms per volt.

N.B.—BEFORE LEAVING THE STROMBERG-CARLSON RADIO RECEIVER IN A CUSTOMER'S HOME, SEE THAT EVERYBODY WHO IS LIKELY TO HANDLE THE RECEIVER FULLY UNDERSTANDS ITS OPERATION. BY SO DOING MANY UNNECESSARY SERVICE CALLS MAY BE AVOIDED.

Stromberg-Carlson

STROMBERG-CARLSON
SERVICE BULLETIN, No. 505

Stromberg-Carlson Model 505

FIVE VALVE BATTERY-OPERATED SUPERHETERODYNE.

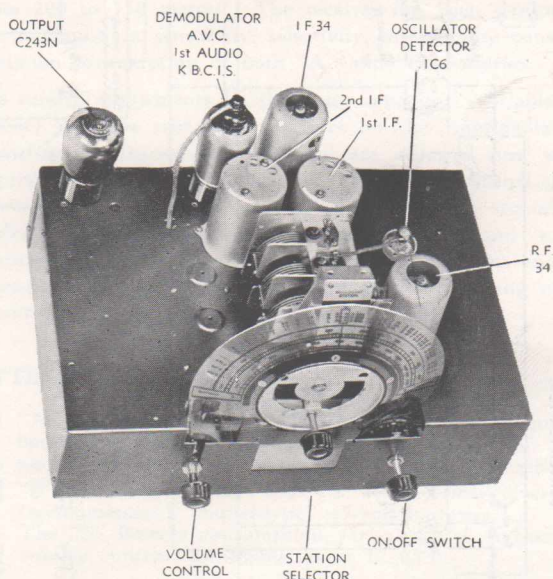

Chassis of Model 505

This Service Bulletin is issued free of charge to all authorised Stromberg-Carlson Dealers. Applications for additional copies should be made direct to the nearest Distributor.

Stromberg-Carlson (Australasia) Ltd. reserves the right to make changes in design details at any time without incurring any obligations to install same on radio receivers previously sold.

Stromberg-Carlson Model 505 Superheterodyne

FIVE VALVE BATTERY-OPERATED SUPERHETERODYNE.

1. GENERAL DESCRIPTION OF RECEIVER:

This receiver is a 5-valve battery-operated superheterodyne with Automatic Volume Control, designed for use on the broadcast band from 200 to 550 metres. The receiver has been designed to obtain the maximum in sensitivity, selectivity, and quality consistent with a minimum consumption of both "A" and "B" batteries.

The tuning adjustments on the gang capacitor (variable tuning condenser) and the trimmer capacitors on the Intermediate Frequency Transformers (tuned to 175 k.c.) are adjusted and sealed at the factory at the time of calibration. These adjustments should on no account be touched, or the seals broken, unless a specially calibrated oscillator and indicating instrument are to hand whereby such adjustments can be successfully carried out. In any repairs or adjustments the above remarks in regard to the gang capacitor and intermediate transformers should be carefully noted.

2. BATTERIES:

- (i.) "A" Battery—This is a 2-volt storage battery or equivalent 2-volt battery, having a (recommended) capacity of at least 80 ampere-hours. The "A" battery drain is 0.5 ampere.
- (ii.) "B" Batteries—These comprise three heavy-duty, super, or (recommended) "Superdyne" 45-volt batteries.
The "B" Battery consumption varies with the adjustment of the volume control, averaging about 12 M.A.

To connect the battery leads correctly, reference should be made to the designation tabs on the leads, and to the colour code as shown on the circuit diagram on Page 2.

The "A" battery and the three "B" batteries may be placed on the lower shelf of the speaker compartment of the cabinet.

3. INSTALLATION INSTRUCTIONS:

(a) Aerial.

The sensitivity of this model is such that an aerial placed along the picture moulding in a room, or beneath the carpet, will prove satisfactory. Care should be taken to place all such indoor aerials as far

SERVICE BULLETIN, No. 505 (Continued)

Page 4

away as possible from electric light or power conduits, and, in particular, clear of all unshielded flexible leads, since these latter are prolific radiators of undesirable electrical impulses.

An outdoor aerial is the most efficient. The length of this aerial should be from 32 to 50 feet. In noisy areas (due to electrical interference) the aerial should be erected as far as possible from, and at right angles to, any electric power or light mains.

(b) Earth.

The chassis should be connected to earth by means of an insulated wire attached to a water pipe by an approved clamp. It is preferable to connect the earth lead to the last section of the pipe where it enters the ground, thus avoiding the high resistance contacts at the joints. Should a water system not be available, an efficient earth may be obtained by driving a metal pipe or burying about four square feet of metal sheeting in moist earth; the connection to the metal should preferably be soldered.

4. OPERATION:

(a) Battery Switch.

A three position operating switch is used. When turned fully to the left, the receiver is switched off; both the "A" and "B" battery supplies being disconnected. When turned fully to the right, the

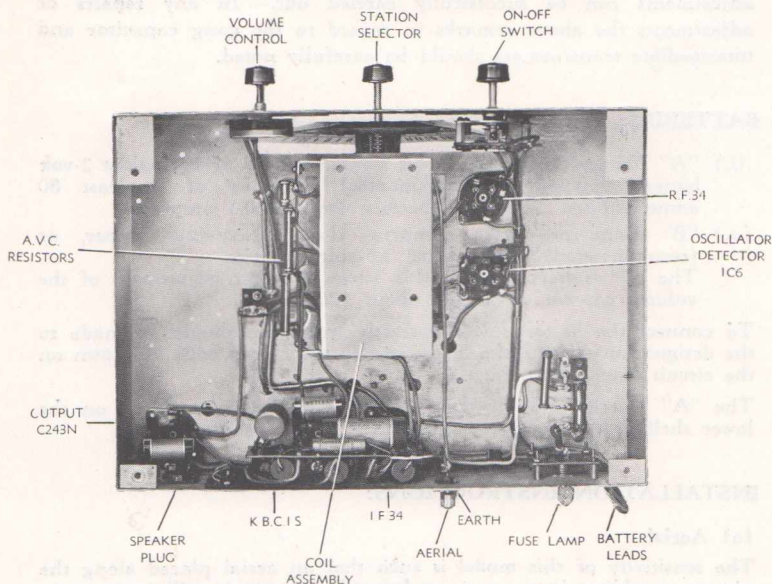

SERVICE BULLETIN, No. 505 (Continued)

Page 5

receiver is ready to operate, and a pilot light is switched on. After tuning to the required station, the switch should then be turned to the centre position. This will extinguish the pilot light only, so removing drain from the battery, and the set will operate in the normal manner.

(b) Automatic Volume Control.

This Model is so designed that the signal voltages fed to the audio system, tend to adjust themselves to a constant level. This signal level is manually controlled and should be adjusted to the desired volume on a station of moderate or high power. The automatic feature will then tend to maintain this volume at a constant level on different signals of wide variations in intensity.

The effects of fading being thus reduced to an absolute minimum, constant attention to the volume control is obviated, especially on the reception of weak and distant stations.

5. PICK-UP JACKS:

Provision is made at the back of the Chassis for the attachment of a Phonograph Pick-up. To operate the pick-up, remove the metal bar between the centre and bottom jacks, and connect the leads from the pick-up to the centre and top jacks, as illustrated.

The metal bar must be replaced when the Receiver is again required for radio operation.

The Volume Control on the Receiver may be used to regulate the audio output from the pick-up.

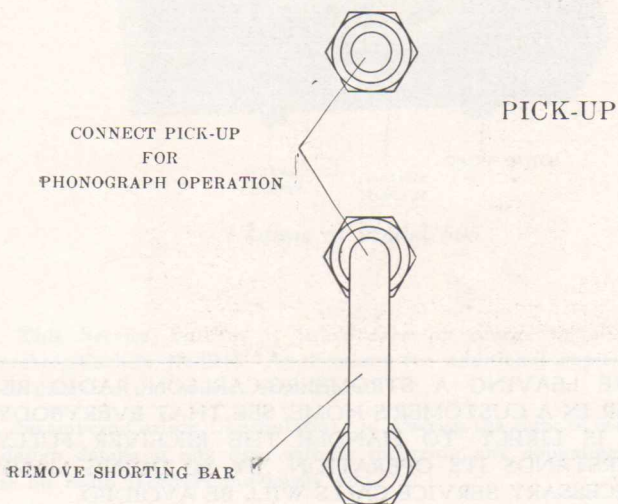

SERVICE BULLETIN, No. 505 (Continued)

Page 6

6. VOLTAGE:

Valve.	Plate.	Screen.	Bias.
34 RF	130	—	-3
1C6 Tetrode section ..	130	—	-3
Oscillator „ ..	—	—	—
34 I.F.	130	—	-3
KBC1S	—	—	-3
C243N Output Tube ..	130	—	-6

All screens and oscillator plate are fed through a 15,000 ohm series resistor from the maximum high tension.

7. COMPONENTS.

The following list of components are given to facilitate the servicing of the receiver and as a guide to replacement.

The numbers refer to position of the components on the assembly panel.

- | | |
|--------------|------------------------|
| 1. .1mf. | 6. 15,000 ohms |
| 2. .001 mf. | 7. .2 megohm |
| 3. 1 megohm | 8. .02 mf. |
| 4. .1 megohm | 9. .5 megohm |
| 5. .02 mf. | Between 1 and 6 .5 mf. |

N.B.—BEFORE LEAVING A STROMBERG-CARLSON RADIO RECEIVER IN A CUSTOMER'S HOME, SEE THAT EVERYBODY WHO IS LIKELY TO HANDLE THE RECEIVER FULLY UNDERSTANDS ITS OPERATION. BY SO DOING MANY UNNECESSARY SERVICE CALLS WILL BE AVOIDED.

Stromberg-Carlson

STROMBERG-CARLSON
SERVICE BULLETIN No. 506

Stromberg-Carlson Model 506

FIVE VALVE BATTERY-OPERATED

Superheterodyne

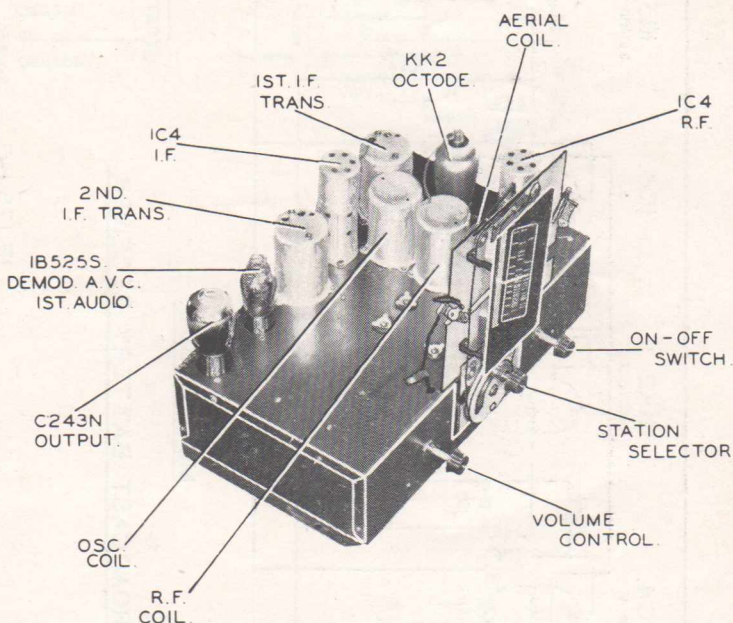

Chassis of Model 506

This Service Bulletin is issued free of charge to all authorised Stromberg-Carlson Dealers. Applications for additional copies should be made direct to the nearest Distributor.

Stromberg-Carlson (Australasia) Ltd. reserves the right to make changes in design details at any time without incurring any obligations to install same on radio receivers previously sold.

STROMBERG - CARLSON (AUSTRALASIA) LIMITED
 SYDNEY AUSTRALIA

DRAWING NO 771.

CHANGES

DRAWN *[Signature]*
 EXAMINED *[Signature]*
 APPROVED MGN DIRECTOR
 DATE 17-12-35

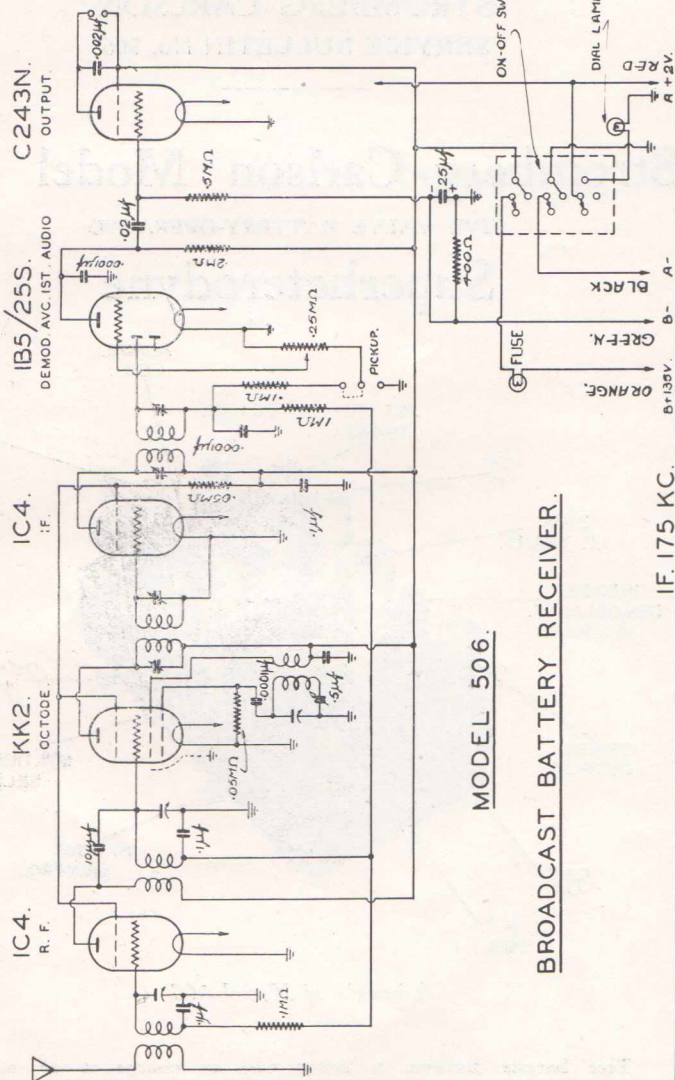

MODEL 506.

BROADCAST BATTERY RECEIVER.

I.F. 175 KC.

Stromberg-Carlson Model 506

FIVE VALVE BATTERY-OPERATED

Superheterodyne

1. GENERAL DESCRIPTION OF RECEIVER.

This receiver is a 5-valve battery-operated superheterodyne with Automatic Volume Control, designed for use on the broadcast band from 200 to 550 metres. The receiver has been designed to obtain the maximum in sensitivity, selectivity, and quality consistent with a minimum consumption of both "A" and "B" batteries.

The tuning adjustments on the gang capacitor (variable tuning condenser) and the trimmer capacitors on the Intermediate Frequency Transformers (tuned to 175 k.c.) are adjusted and sealed at the factory at the time of calibration. These adjustments should on no account be touched, or the seals broken, unless a specially calibrated oscillator and indicating instrument are to hand whereby such adjustments can be successfully carried out. In any repairs or adjustments the above remarks in regard to the gang capacitor and intermediate transformers should be carefully noted.

2. BATTERIES.

(i.) "A" Battery—This is a 2-volt storage battery or equivalent 2-volt battery, having a (recommended) capacity of at least 80 ampere-hours. The "A" battery drain is 0.63 ampere. The "B" battery consumption varies with the adjustment of the volume control, averaging about 13 m.a.

(ii.) "B" Batteries—These comprise three heavy-duty, super, or (recommended) super-service 45-volt batteries.

To connect the battery leads correctly, reference should be made to the designation tabs on the leads, and to the colour code as shown on the circuit diagram on Page 2.

The "A" battery and the three "B" batteries may be placed on the lower shelf of the speaker compartment of the cabinet.

3. INSTALLATION INSTRUCTIONS:

(a) Aerial.

The sensitivity of this model is such that an aerial placed along the picture moulding in a room, or beneath the carpet, will prove satisfactory. Care should be taken to place all such indoor aerials as far away as possible from electric light or power conduits, and, in particular, clear of all unshielded flexible leads, since these latter are prolific radiators of undesirable electrical impulses.

An outdoor aerial is the most efficient. The length of this aerial should be from 30 to 50 feet. In noisy areas (due to electrical interference) the aerial should be erected as far as possible from, and at right angles to, any electric power or light mains.

(b) Earth.

The chassis should be connected to earth by means of an insulated wire attached to a water pipe by an approved clamp. It is preferable to connect the earth lead to the last section of the pipe where it enters the ground, thus avoiding the high resistance contacts at the joints. Should a water system not be available, an efficient earth may

SERVICE BULLETIN No. 506 (Continued)

be obtained by driving a metal pipe or burying about four square feet of metal sheeting in moist earth; the connection to the metal should preferably be soldered.

4. OPERATION:

(a) Battery Switch.

A three-position operating switch is used. When turned fully to the left, the receiver is switched off; both the "A" and "B" battery supplies being disconnected. When turned fully to the right, the receiver is ready to operate, and a pilot light is switched on. After tuning to the required station, the switch should then be turned to the centre position. This will extinguish the pilot light only, so reducing the drain from the battery, and the set will operate in the normal manner.

(b) Automatic Volume Control.

This Model is so designed that the signal voltages fed to the audio system tend to adjust themselves to a constant level. This signal level is manually controlled and should be adjusted to the desired volume on a station of moderate or high power. The automatic feature will then tend to maintain this volume at a constant level on different signals of wide variations in intensity.

The effects of fading being thus reduced to an absolute minimum, constant attention to the volume control is obviated, especially on the reception of weak and distant stations.

5. PICK-UP JACK:

Provision is made at the back of the Chassis for the attachment of a Phonograph Pick-up. To operate the pick-up, remove the metal bar between the centre and bottom jacks, and connect the leads from the pick-up to the centre and top jacks, as illustrated.

The metal bar must be replaced when the Receiver is again required for radio operation.

The Volume Control on the Receiver may be used to regulate the audio output from the pick-up.

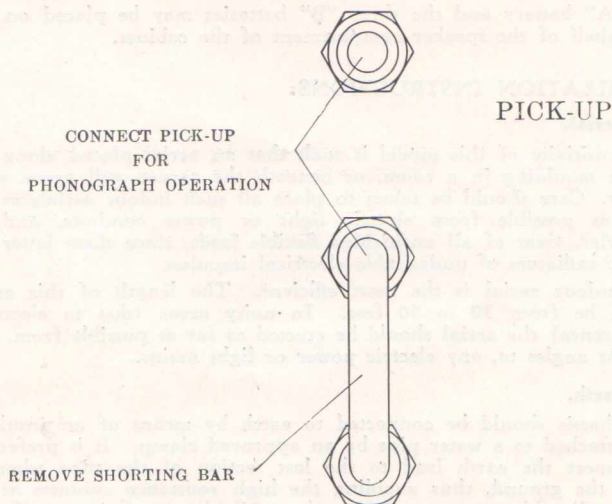

SERVICE BULLETIN No. 506 (Continued)

6. VOLTAGES:

Valve.	Plate.	Screen.	Bias.
1C4 R.F.	130	—	—
KK2 Pentode	130	—	—
Triode	130	—	—
1C4 I.F.	130	—	—
1B5-25S	60	—	—
C243N Output	130	130	— 5

The 1C4 and KK2 screens are fed through a 50,000 ohm series resistor from the max. high tension.

N.B.—BEFORE LEAVING A STROMBERG-CARLSON RADIO RECEIVER IN A CUSTOMER'S HOME, SEE THAT EVERYBODY WHO IS LIKELY TO HANDLE THE RECEIVER FULLY UNDERSTANDS ITS OPERATION. BY SO DOING MANY UNNECESSARY SERVICE CALLS WILL BE AVOIDED.

(Continued) 1914-1915 INTELLECTUAL PROPERTY

Year	Patent No.	Inventor	Assignor
1914	1,234,567	J. H. Smith	ABC Corp.
1915	1,345,678	M. N. Jones	DEF Ltd.
1916	1,456,789	P. Q. Brown	GHI Inc.
1917	1,567,890	R. S. White	JKL Co.
1918	1,678,901	T. U. Black	MNO & Co.
1919	1,789,012	V. W. Green	PQR & Sons
1920	1,890,123	X. Y. Blue	STU & Partners

Notes: The above list is based on the records of the United States Patent Office for the years 1914-1920. It is not intended to be a complete list of all patents granted during this period.

Copyright 1920 by W. A. Pepperday & Co. Ltd. All rights reserved. This document is the property of W. A. Pepperday & Co. Ltd. and is loaned to you for your information only. It is not to be reproduced or distributed without the written consent of W. A. Pepperday & Co. Ltd.

Stromberg-Carlson

STROMBERG - CARLSON

SERVICE BULLETIN No. 533

Stromberg-Carlson Model 533 Superheterodyne

ALL ELECTRIC FOUR VALVES AND RECTIFIER

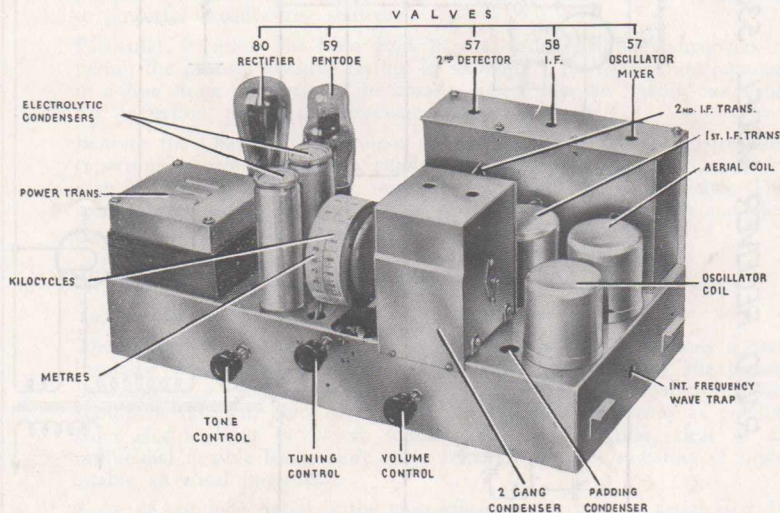

Chassis of Model 533

This Service Bulletin is issued free of charge to all authorised Stromberg-Carlson Dealers. Applications for additional copies should be made direct to the nearest Distributor.

Stromberg-Carlson (Australasia) Ltd. reserve the right to make changes in design details at any time without incurring any obligations to instal same on radio receivers previously sold.

STROMBERG - CARLSON

SERVICE BULLETIN No. 533 (Continued)

Page 3

Stromberg-Carlson Model 533 Superheterodyne

ALL ELECTRIC FOUR VALVES AND RECTIFIER

1. GENERAL DESCRIPTION OF RECEIVER:

This Receiver employs the improved superheterodyne circuit designed and developed in the Stromberg-Carlson Laboratories.

The Tone Control on this model has been incorporated to enable the operator to manually regulate the tonal quality of the receiver to suit the wide and varying range of reception conditions.

All the components and the R.F. Valves on this Model have been carefully and thoroughly shielded to a degree hitherto not attained commercially in Australia, the result being that this Model does not "pick-up" or amplify unwanted signals and extraneous electrical impulses. This condition is particularly desirable in "noisy" locations and in areas close to powerful broadcasting stations.

Particular attention has been paid to the outlay of the components to permit the greatest possible facility in servicing. The Valves are mounted in a line along the back of the chassis, where they are readily accessible for inspection, testing or replacement.

Beneath the Chassis all the minor components consisting of resistors and capacitors, are mounted on a single strip and are plainly numbered for ease in checking their values, testing voltages and general servicing. This method of assembly also contributes to the mechanical strength and electrical efficiency of the Chassis.

2. INSTALLATION INSTRUCTIONS:

(a) Aerial.

The sensitivity of this model is such that in most installations a well insulated wire about 20 to 30 feet in length, placed along the picture moulding in a room, or beneath the carpet, will prove satisfactory. Care should be taken to place all such indoor aerials, as far away as possible from electric light or power conduits, and in particular, clear of all unshielded flexible leads, since these latter are prolific radiators of undesirable electrical impulses.

Since an out-door Aerial is the most efficient, this type of aerial is to be preferred—especially where facilities for such are already obtainable. In country areas, where the maximum receptivity of the receiver is desired, an outdoor aerial of from 30 to 50 feet in length is recommended.

In noisy areas (due to electrical interference) the aerial should be erected as far as possible from and at right angles to any electric power or light mains.

As a further precaution against undesirable pick-up the lead-in should be of the shielded type with the outer sheath connected to earth.

(b) Earth.

The chassis should be connected to earth by means of an insulated wire attached to a water pipe by an approved clamp. It is preferable to connect the earth lead to the last section of the pipe where it enters

STROMBERG - CARLSON

Page 4

SERVICE BULLETIN No. 533 (Continued)

the ground, thus avoiding the high resistance contacts at the joints. Should a water system not be available, an efficient earth may be obtained by driving a metal pipe or burying about four square feet of metal sheeting in moist earth, the connection to the metal should preferably be soldered.

(c) Voltage Adjustment Panel.

Before leaving the factory the power lead is connected to the 240 volt tapping on the power transformer. If the line voltage differs from this, the power lead should be unsoldered from the 240 volt tapping and soldered to the tapping which is marked with the voltage nearest to, but not less than, the measured line voltage in the locality. The voltage tappings for 200, 220, 240, 260 volts are designated on the power transformer.

When making any adjustment, **SEE THAT THE POWER PLUG IS COMPLETELY REMOVED FROM THE SOCKET OF THE SUPPLY SOURCE.**

(d) Trimmer Adjustments.

The tuning adjustments on the gang capacitor (the variable gang tuning condenser) and the trimmer capacitors on the Intermediate Frequency Transformers (tuned to 465 k.c.) are adjusted and sealed at the factory at the time of calibration. These adjustments should on no account be touched or the seals broken unless a specially calibrated oscillator and indicating instrument are available whereby such adjustments can be successfully carried out. In any repairs or adjustments the above remarks in regard to the gang capacitor and intermediate transformers should be carefully noted.

3. OPERATION:

(a) General.

The more sensitive and selective the Receiver is the more care should be taken in its operation and tuning, to obtain the best results. In model 533 the left-hand knob is the "Tone Control"; the centre knob is the tuning control; the right-hand knob is the volume control. Improper tuning will affect the quality of reproduction. Care should be taken to keep the volume control well down, then adjust the tuning control to the point of maximum undistorted signal, thereafter adjusting the volume to the desired level. The 533 Receiver is a very sensitive instrument and with the volume control adjusted to, or near to, its maximum position a certain amount of background noise and hiss is inevitable. In general, the greater the sensitivity the greater the noise level. This condition, however, will only be noticed when the receiver is adjusted for very distant and weak signals. Interstate reception will be normally obtained with ease and greater volume and margin. Every care has been taken to design the receiver so that the ratio of noise level is kept as low as possible consistent with high sensitivity.

(b) Tone Control.

Under the normal conditions of reception, such as from a good local station, the tone control should be set at the "off" position, that is, turned as far as possible to the right. The Receiver is now set for "Brilliance" and the full range of audio frequencies from the highest to the lowest notes will be reproduced in their true values. Under conditions of noisy reception whether due to natural static, local electrical interference, or when receiving weak or distant stations, more

STROMBERG - CARLSON

SERVICE BULLETIN No. 533 (Continued)

pleasing reception will result with the tone control turned to the "on" position; this will result in a "Mellow" tone, free from the high frequency background of noise, so disturbing under the conditions outlined. The tone control may, of course, be set at any intermediate position, between "Brilliant" and "Mellow" to suit the condition of reception or the taste of the operator.

4. VALVES:

All Receivers leaving the factory are equipped with valves inserted into the sockets. If for any reason it becomes necessary to remove the valves, care should be taken to see that each one is replaced in the socket from which it was taken. The photograph of the chassis on Page 1 shows the type and function of the valves and their exact location.

Function of Valve.	Type of Valve.
Oscillator-Mixer	57
I.F.	58
Detector	57
Power Pentode	59
Rectifier	80

5. SPEAKER:

The speaker in this Model is the Dynamic or moving coil type, and is matched to the pentode output valve. The field coil being used at the date of issue of this Bulletin has a resistance of 1000 ohms. The speaker terminates in a four-pin plug at the receiver chassis.

THIS PLUG SHOULD NOT BE REMOVED WHILE THE CURRENT IS TURNED ON.

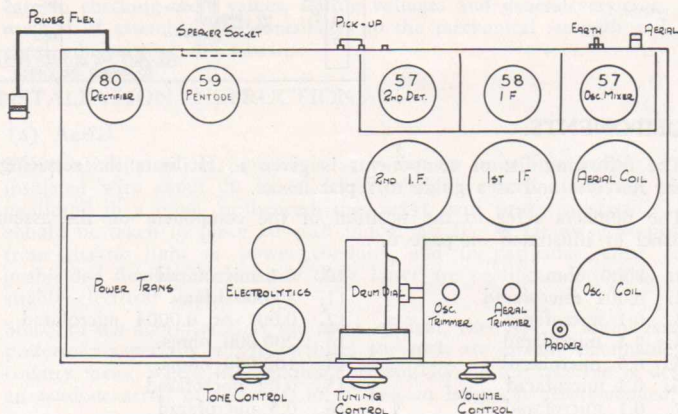

6. PICK-UP JACKS:

Provision is made at the back of the chassis for the attachment of a phonograph pick-up. Unless the receiver is issued from the factory as a phono-radio combination, the pick-up jacks are shorted with a metal bar which must not be removed unless it is desired to insert a pick-up into the terminals. When the pick-up is in use, care must be taken to see that the volume control on the receiver is turned right off, thereafter using the volume control supplied with the pick-up.

STROMBERG - CARLSON

Page 6

SERVICE BULLETIN No. 533 (Continued)

7. VOLTAGES:

All voltages shown in the chart on Page 6 are those which should be obtained when using a 0-10-120-300-600 volt voltmeter having a resistance of 1,000 ohms per volt. Voltages shown below 10 are to be read on 0-10 scale, those below 120 on the 0-120 scale, those below 300 on the 0-300 scale, and those above 300 on the 0-600 scale. It is important to note that other voltmeters having different internal resistances will give voltage readings different from those mentioned in the following table. Therefore, a 1,000 ohm. per volt voltmeter should be used.

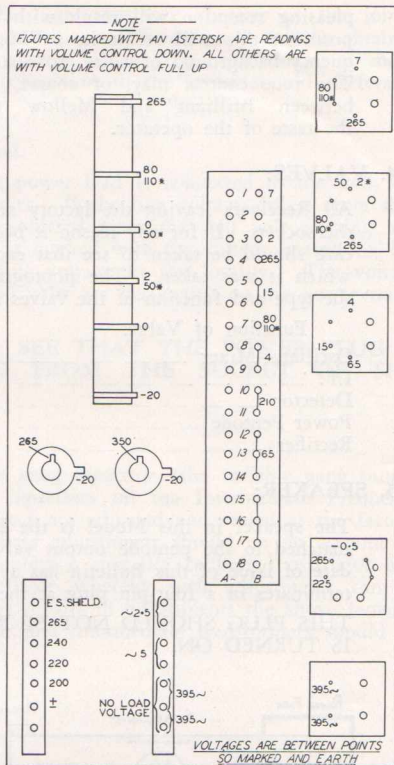

8. COMPONENTS:

The following list of components is given to facilitate the servicing of the Receiver and as a guide to replacements.

The numbers refer to the position of the component on the assembly panel as illustrated on page 6.

- | | |
|---------------------|--------------------------------|
| 1. 8000 ohms. | 10. 0.1 microfarad |
| 2. 0.001 microfarad | 11. 50,000 ohms. |
| 3. 0.1 microfarad | 12. 0.001 or 0.0004 microfarad |
| 4. 0.1 microfarad | 13. 200,000 ohms. |
| 5. 0.5 microfarad | 14. 100,000 ohms. |
| 6. 0.1 microfarad | 15. 0.02 microfarad |
| 7. 0.1 microfarad | 16. 0.5 microfarad |
| 8. 0.5 microfarad | 17. 0.004 microfarad |
| 9. 15,000 ohms. | |

Voltage Divider Values: 5,300 ohms, 2,500 ohms, 150 ohms, 220 ohms.
Speaker Field: 1,000 ohms.

9. FAULTS:

A list of probable faults with their causes is given below. Having located the fault, it is necessary to adjust or repair the component in question or, if beyond repair, to remove and replace it with a good component.

STROMBERG - CARLSON

Page 7

SERVICE BULLETIN No. 533 (Continued)

(a) No Signals.

1. Examine the house power socket for disconnection.
2. Speaker plug not properly in socket or failing to make contact.
3. Defective valves or valves failing to make contact in sockets, or screen-grid clips making faulty connection.
4. Defective 80 Rectifier or 59 Pentode Valve.
5. Defective dynamic speaker due to disconnection in the transformer or voice coil.
6. Disconnection in voltage-divider.
7. Defective by-pass condenser.
8. Resistor or condenser shorting to frame or burnt out.
9. Volume control moving arm shorting to frame.

(b) No Signals when Audio End appears in Good Order.

1. Intermediate Frequency Transformer leads shorting to frame or open circuit coils.
2. Defective Detector-Oscillator Valve.
3. Defective resistor in cathode circuit of Detector-Oscillator Valve.
4. Defective oscillator coil or aerial coil. (See C.6.)
5. Grid Clip off valve or shorting to frame.

(c) Weak Signals.

1. Aerial trimmer not properly adjusted. See installation instructions 2 (d).
2. Trimmers on gang-condenser out of adjustment. Access to these trimmers is provided on the top of the gang shield.
3. Insufficient line voltage or voltage set at wrong tapping. See 2 (c).
4. Defective dynamic speaker. See a. (5).
5. Defective valves, or valves failing to make proper contact in sockets.
6. Defective aerial bobbin. In most instances it will not be possible to rectify these on site, they should be returned to the factory for repair.
7. Aerial filter circuit open-circuit or shorting to frame.

(d) Weak Signal with Distortion.

1. Secondary of I.F. Transformer or their leads shorting to frame.
2. Defective 57 or 59 valve.
3. Defective coupling condenser (from plate of detector to grid of pentode).
4. Valve Sockets or grid clips making poor contact.

(e) Poor Quality and/or Overloading Accompanied by Hum.

1. Receiver not correctly tuned.
2. Speaker cone assembly off centre and touching sides. Rectify by adjusting screw in centre of speaker cone.
3. Defective valve, particularly the 59 Valve.
4. Defective or burnt out resistors in plate circuit of detector or grid circuit of pentode.
5. Defective Resistor in cathode circuit of second detector.
6. Distortion is sometimes due to an "out of phase" condition of the reflected waves from Broadcasting Stations, and is not attributable to any fault in the receiver.

STROMBERG - CARLSON

Page 8

SERVICE BULLETIN No. 533 (Continued)

(f) Howling and Microphonism.

1. Defective Valves.
2. Defective Speaker.

(g) Excessive Hum.

1. Defective Speaker.
2. Defective Valves, particularly Pentode.
3. Defective or shorted resistors.
4. Defective coupling condenser (plate of detector to grid of pentode).
5. Shorting bar across pick-up terminal missing or making defective contact.

(h) Fading.

1. Natural atmospheric causes.
2. Defective Valves.
3. Broadcast station troubles.
4. Defective aerial due to its periodic contact with nearby objects as a result of swinging.
5. Extreme line voltage fluctuation. This Model is designed to operate between 200-260 volts. Any deviation from this will cause undesirable effects.
6. Loose or high resistance joints. Visually examine all soldered connections and when necessary test with a pair of pliers.

(i) Noise.

1. Remove aerial and earth from receiver. If noise ceases, the trouble is due to local interference such as flashing signs, refrigerators, proximity of power transformers, lifts or tram wires.
2. Atmospheric disturbances such as static. Direct attention of user to this phenomenon particularly during summer months.
3. Defective house lighting circuit. Check electric light and power sockets, switches, extension cords and electrical accessories for bad connections.
4. Defective valves due to loose elements.
5. See h (6.)
6. Defective Speaker. Check adjustment of voice coil and examine rear of cone.
7. Aerial intermittently touching surrounding objects.
8. Defective resistor.

N.B.—BEFORE LEAVING A STROMBERG-CARLSON RADIO RECEIVER IN A CUSTOMER'S HOME, SEE THAT EVERYBODY WHO IS LIKELY TO HANDLE THE RECEIVER FULLY UNDERSTANDS ITS OPERATION. BY SO DOING MANY UNNECESSARY SERVICE CALLS WILL BE AVOIDED.

Stromberg-Carlson

STROMBERG - CARLSON
SERVICE BULLETIN No. 534

Stromberg-Carlson Model 534 Superheterodyne

ALL ELECTRIC FOUR VALVES AND RECTIFIER

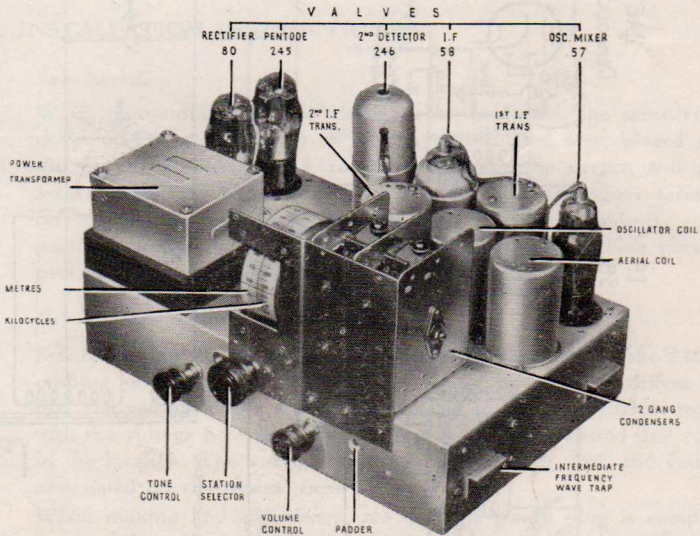

Chassis of Model 534

This Service Bulletin is issued free of charge to all authorised Stromberg-Carlson Dealers. Applications for additional copies should be made direct to the nearest Distributor.

Stromberg-Carlson (Australasia) Ltd. reserve the right to make changes in design details at any time without incurring any obligations to instal same on radio receivers previously sold.

STROMBERG-CARLSON (AUSTRALASIA) LIMITED
 SYDNEY AUSTRALIA

DRAWING NO Z153

CHANGES

DRAWN T.W.S.,
 EXAMINED *Aut.*
 APPROVED S.J.T.M.
 DATE 2-11-33

RADIO RECEIVER MODEL 534

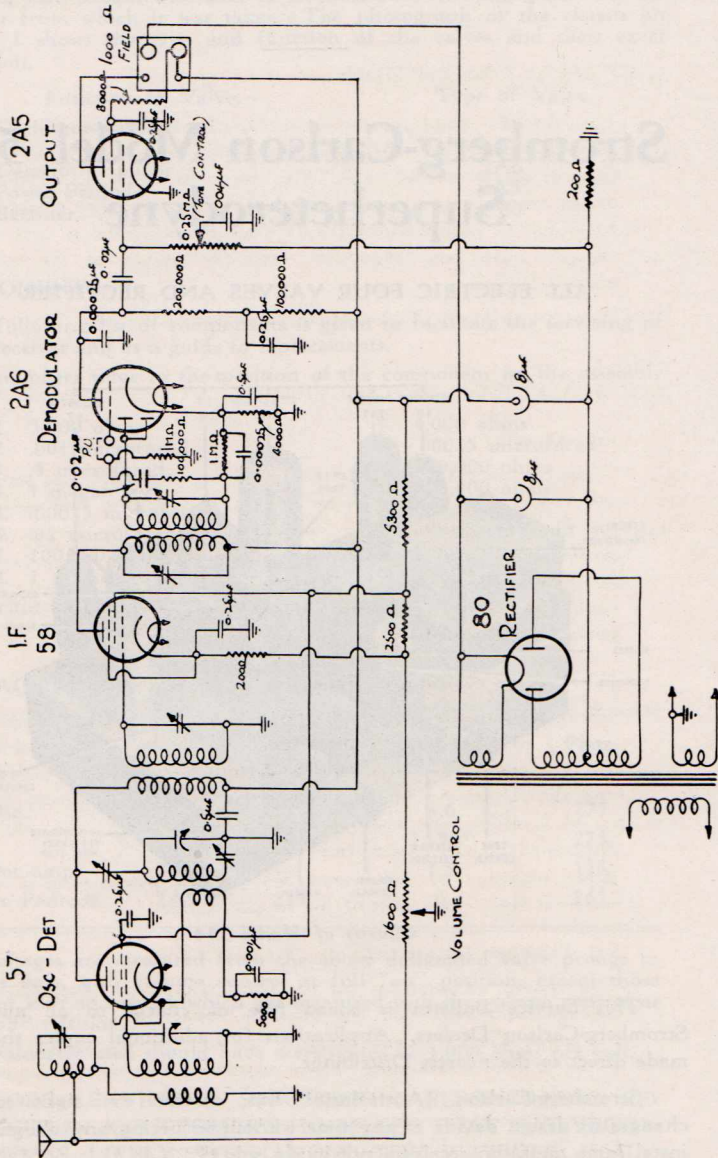

SERVICE BULLETIN No. 534 (Continued)

Page 3

Stromberg-Carlson Model 534 Superheterodyne

ALL ELECTRIC FOUR VALVES AND RECTIFIER

1. GENERAL DESCRIPTION:

This receiver employs the latest superheterodyne circuit design and takes advantage of the new duo-diode high mu triode, combined detector and amplifier valve. The new pentode is also employed. This design results in a still further advance in the quality of reproduction. In order to obtain correct acoustical balance, much care and forethought have been expended upon the design of the cabinet and speaker baffle.

The "noise-level" of this model is exceptionally low.

2. INSTALLATION INSTRUCTIONS:

(a) Aerial.

While an outdoor aerial is always to be preferred, the sensitivity of this model is such that 20 to 30 feet of insulated wire, placed along the picture moulding in a room, or beneath the carpet, will prove satisfactory. Care should be taken to place all such indoor aerials, as far away as possible from electric light or power conduits, and in particular, clear of all unshielded flexible leads, since these latter are prolific radiators of undesirable electrical impulses.

(b) Voltage Adjustment Panel.

Before leaving the factory the power lead is connected to the 240 volt tapping on the power transformer. If the line voltage differs from this, the voltage switch should be adjusted to the tap which is marked with the voltage nearest to, but not less than, the measured line voltage in the locality. The voltage tappings for 200, 220, 240, 260 volts are designated on the power transformer.

When making any adjustment, **see that the power plug is completely removed from the socket of the supply source.**

(c) Trimmer Adjustments.

The tuning adjustments on the gang capacitor (the variable gang tuning condenser) and the trimmer capacitors on the Intermediate Frequency Transformers (tuned to 465 k.c.) are adjusted at the factory at the time of calibration. These adjustments should on no account be touched unless a specially calibrated oscillator and indicating instrument are available whereby such adjustments can be successfully carried out. In any repairs or adjustments the above remarks in regard to the gang capacitor and intermediate transformers should be carefully noted.

STROMBERG - CARLSON

SERVICE BULLETIN No. 534 (Continued)

Page 4

3. VALVES:

All Receivers leaving the factory are equipped with valves inserted into the sockets. If for any reason it becomes necessary to remove the valves, care should be taken to see that each one is replaced in the socket from which it was taken. The photograph of the chassis on Page 1 shows the type and function of the valves and their exact location.

Function of Valve.	Type of Valve.
Oscillator-Mixer	57
I.F.	58
Detector-amplifier	2A6
Power Pentode	2A5
Rectifier	80

4. COMPONENTS:

The following list of components is given to facilitate the servicing of the Receiver and as a guide to replacements.

The numbers refer to the position of the component on the assembly panel.

1. 5,000 ohms	9. 4,000 ohms
2. .001 microfarad	10. .00025 microfarad
3. .5 microfarad	11. 200,000 ohms
4. 1 megohm	12. 100,000 ohms
5. .00025 microfarad	13. —
6. .02 microfarad	14. .02 microfarad
7. 100,000 ohms	15. 8,000 ohms
8. 1 megohm	16. —

Capacitor block: 4 red leads 0.25 microfarad.
1 yellow lead 0.5 microfarad.

5. VOLTAGES:

Valve.	Screen.	Cathode	Plate.
Det.-Osc. 57	95, 130*	4.6	275
I.F. 58	95, 130*	2, 50*	275
2nd Det.-amp. . . . 2A6	—	1.5	125
Output Pentode . . . 2A5	235	0	265

All voltages are measured from the above designated valve prongs to chassis base, with volume control at full "on" position, except those marked with an asterisk which are measured with the volume control at the "off" position.

The voltmeter used should have a resistance of 1,000 ohms per volt.

N.B.—BEFORE LEAVING A STROMBERG-CARLSON RADIO RECEIVER IN A CUSTOMER'S HOME, SEE THAT EVERYBODY WHO IS LIKELY TO HANDLE THE RECEIVER FULLY UNDERSTANDS ITS OPERATION. BY SO DOING MANY UNNECESSARY SERVICE CALLS WILL BE AVOIDED.

Stromberg-Carlson

STROMBERG-CARLSON
SERVICE BULLETIN No. 544

Stromberg-Carlson Model 544 UNIVERSAL A.C.-D.C. Superheterodyne

ALL ELECTRIC FOUR VALVES AND RECTIFIER

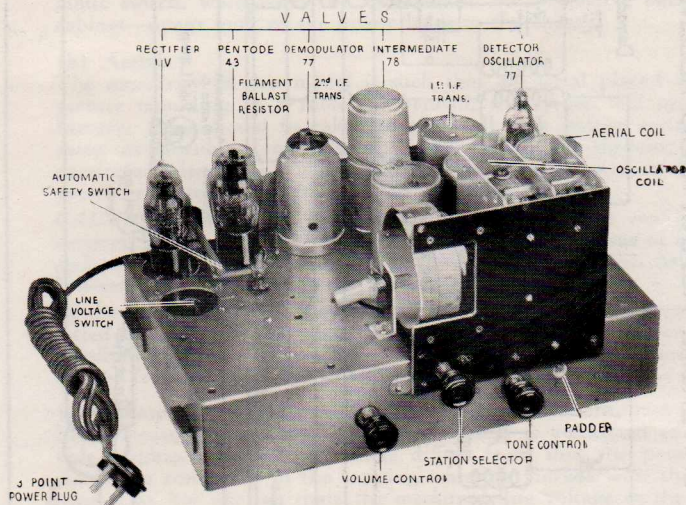

Chassis of Model 544

This Service Bulletin is issued free of charge to all authorised Stromberg-Carlson Dealers. Applications for additional copies should be made direct to the nearest Distributor.

Stromberg-Carlson (Australasia) Ltd. reserve the right to make changes in design details at any time without incurring any obligations to instal same on radio receivers previously sold.

Stromberg-Carlson Model 544 UNIVERSAL A.C.-D.C. Superheterodyne

ALL ELECTRIC FOUR VALVES AND RECTIFIER

1. GENERAL DESCRIPTION OF RECEIVER:

The Universal A.C.-D.C. Model is particularly adapted to areas where the electric supply is direct current.

A number of such areas are at present in the process of conversion to an alternating current supply. In these circumstances the 544 Receiver is ideal, in that it operates with equal efficiency on either A.C. or D.C. supplies.

2. INSTALLATION INSTRUCTIONS:

(a) Safety.

Every precaution has been taken to render the 544 A.C.-D.C. Receiver perfectly safe. Nevertheless, due care should be exercised in the installation of this type of receiver.

Do not make any adjustments to the receiver, aerial, or any lead connected thereto, without first of all disconnecting the receiver from the supply mains.

As a further protection, the 544 chassis has been fitted with an automatic switch, which—on the removal of the protective back on the cabinet—opens both of the power leads to the chassis.

(b) Aerial.

The sensitivity of this model is such that an aerial placed along the picture moulding in a room, or beneath the carpet, will prove satisfactory. Care should be taken to place all such indoor aerials as far away as possible from electric light or power conduits, and, in particular, clear of all unshielded flexible leads, since these latter are prolific radiators of undesirable electrical impulses.

CAUTION. When an outdoor aerial is installed on any A.C.-D.C. receiver, care should be taken to place the aerial well clear of buildings, and to particularly avoid any possibility of bodily contact being made between the aerial and any metal roofing.

In the Stromberg-Carlson A.C.-D.C. Model the aerial is normally protected by two specially selected condensers. Only on the very remote possibility of the *two* condensers breaking down would there be any danger from contact with the aerial circuit.

(c) Voltage Adjustment Panel and Power Connections.

Before leaving the factory the power switch is connected to the 240 volt tapping. If the line voltage differs from this, the power switch should be connected to the tapping which is marked with the voltage nearest to, but not less than, the measured line voltage in the locality. The voltage tappings for 220, 240, 260 volts are designated on the power switch. The three-wire power cable consists of the two power leads, red and black, and an earth lead, green.

When connected to D.C., it is imperative that the RED lead be connected to the POSITIVE and the BLACK to the NEGATIVE of the supply mains. If reversed the filaments will light but the receiver will not operate.

When connected to A.C. it is preferable for the RED lead to be connected to the ACTIVE and the BLACK to the NEUTRAL of the supply mains.

Note.—To ascertain ACTIVE, check with test lamp (240 volt) between line and earth. The ACTIVE will be indicated by the lamp lighting. No light will be observed between NEUTRAL and earth.

When making any adjustment, see that the power plug is completely removed from the socket of the supply source.

STROMBERG - CARLSON

(d) **Trimmer Adjustments.**

The tuning adjustments on the gang capacitor (the variable gang tuning condenser) and the trimmer capacitors on the Intermediate Frequency Transformers (tuned to 465 k.c.) are adjusted at the factory at the time of calibration. These adjustments should on no account be touched unless a specially calibrated oscillator and indicating instrument are available whereby such adjustments can be successfully carried out. In any repairs or adjustments the above remarks in regard to the gang capacitor and intermediate transformers should be carefully noted.

3. VALVES:

All Receivers leaving the factory are equipped with valves inserted into the sockets. If for any reason it becomes necessary to remove the valves, care should be taken to see that each one is replaced in the socket from which it was taken. The photograph of the chassis on Page 1 shows the type and function of the valves and their exact location.

Function of Valve.	Type of Valve.
Oscillator-Mixer	77
I.F.	78
Detector	77
Power Pentode	43
Rectifier	1.V.

4. COMPONENTS:

The following list of components is given to facilitate the servicing of the Receiver and as a guide to replacements.

The numbers refer to the position of the component on the assembly panel.

- | | |
|--------------------|--------------------|
| 1. .001 microfarad | 9. .001 microfarad |
| 2. 4000 ohms | 10. 200,000 ohms |
| 3. .5 microfarad | 11. 100,000 ohms |
| 4. 15,000 ohms | 12. .02 microfarad |
| 5. 15,000 ohms | 13. 750 ohms |
| 6. 200 ohms | 14. 25 microfarad |
| 7. 15,000 ohms | 15. .01 microfarad |
| 8. .5 megohm | 16. .02 microfarad |

Capacitor block: 4 red leads 0.25 microfarad.
1 yellow lead 0.5 microfarad.

5. VOLTAGES:

Valve.	Screen.	Plate.	Cathode.
Det.-Osc. 77	65, 85*	155	5
I.F. 78	65, 85*	155	2, 35*
2nd Det. 77	20	50	3
Output 43	155	155	20

All voltages are measured from the above designated valve prongs to the common negative bus, with volume control at full "on" position, except those marked with an asterisk, which are measured with the volume control at the "off" position.

The voltmeter used should have a resistance of 1000 ohms per volt.

N.B.—BEFORE LEAVING A STROMBERG-CARLSON RADIO RECEIVER IN A CUSTOMER'S HOME, SEE THAT EVERYBODY WHO IS LIKELY TO HANDLE THE RECEIVER FULLY UNDERSTANDS ITS OPERATION. BY SO DOING MANY UNNECESSARY SERVICE CALLS WILL BE AVOIDED.

Stromberg-Carlson

STROMBERG-CARLSON
SERVICE BULLETIN No. 554

Stromberg-Carlson Model 554 Superheterodyne

ALL-ELECTRIC, ALL-WAVE

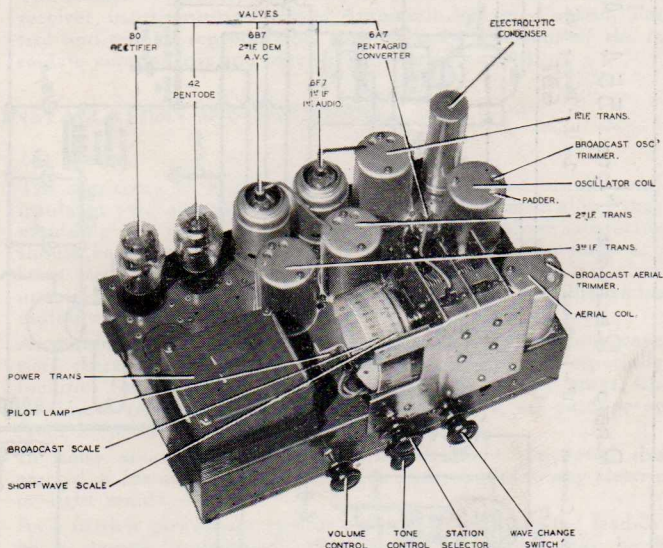

Chassis of 554 Model

This Service Bulletin is issued free of charge to all authorised Stromberg-Carlson Dealers. Applications for additional copies should be made direct to the nearest Distributor.

Stromberg-Carlson (Australasia) Ltd. reserves the right to make changes in design details at any time without incurring any obligations to install same on radio receivers previously sold.

Stromberg-Carlson Model 554 Superheterodyne

**ALL-ELECTRIC, ALL-WAVE
FOUR VALVES AND RECTIFIER**

1. GENERAL DESCRIPTION OF RECEIVER:

This model employs the latest superheterodyne principles and, in addition, incorporates the short-wave spectrums, 16 to 95 metres.

By means of a special circuit, developed by the Stromberg-Carlson (Australasia) Limited Laboratories, it is now possible to offer a receiver having 7-valve performance, within the compass of 5 valves.

This new development employs the latest dual-purpose valves, the 6A7, 6F7 and 6B7. This circuit must not be confused with the Reflex principle and its attendant limitations.

The Model 554 offers, therefore, a combined broadcast and short-wave receiver, incorporating Delayed Automatic Volume Control, Tone Control and quality reproduction, possible only by means of the most up-to-date components and efficiently designed circuits.

2. INSTALLATION INSTRUCTIONS:

(a) Aerial.

The sensitivity of this model is such that in most installations a well-insulated wire about 20 to 30 feet in length, placed along the picture moulding in a room, or beneath the carpet, will prove satisfactory. Care should be taken to place all such indoor aerials as far away as possible from electric light or power conduits, and in particular, clear of all unshielded flexible leads, since these latter are prolific radiators of undesirable electrical impulses.

An outdoor aerial is the most efficient, especially for short-wave reception, therefore this type of aerial is to be preferred—especially where facilities for such are readily obtainable. In country areas, where the maximum receptivity of the receiver is desired, an outdoor aerial of from 30 to 50 feet in length is recommended.

In noisy areas (due to electrical interference) the aerial should be erected as far as possible from and at right angles to any electric power or light mains.

As a further precaution against undesirable pick-up, the lead-in should be a special "transposed" type, details of which may be had on application to Stromberg-Carlson (Australasia) Ltd.

Do not use shielded lead-in wire for short-wave reception.

(b) Earth.

The chassis should be connected to earth by means of an insulated wire attached to a water pipe by an approved clamp. It is preferable to connect the earth lead to the last section of the pipe where it enters the ground, thus avoiding the high resistance contacts at the joints. Should a water system not be available, an efficient earth may be obtained by driving a metal pipe or burying about four square feet of metal sheeting in moist earth; the connection to the metal should preferably be soldered.

SERVICE BULLETIN No. 554 (Continued)

(c) Voltage Adjustment Panel.

Before leaving the factory the power lead is connected to the 240-volt tapping on the power transformer. If the line voltage differs from this the power lead should be unsoldered from the 240-volt tapping and soldered to the tapping which is marked with the voltage nearest to, but not less than, the measured line voltage in the locality. The voltage tappings for 200, 220, 240, 260 volts are designated on the power transformer.

When making any adjustment, see that the power plug is completely removed from the socket of the supply source.

(d) Trimmer Adjustments.

The tuning adjustments on the gang capacitor (the variable gang tuning condenser) and the trimmer capacitors on the Intermediate Frequency Transformers (tuned to 465 k.c.) are adjusted and sealed at the factory at the time of calibration. These adjustments should on no account be touched or the seals broken unless a specially calibrated oscillator and indicating instrument are available whereby such adjustments can be successfully carried out. In any repairs or adjustments the above remarks in regard to the gang capacitor and intermediate transformers should be carefully noted.

3. OPERATION:

(a) Automatic Volume Control.

This Model is so designed that the signal voltages fed to the audio system, tend to adjust themselves to a constant level. This signal level is manually controlled and should be adjusted to the desired volume on a station of moderate or high power. The automatic feature will then tend to maintain this volume at a constant level on different signals of wide variations in intensity.

The effects of fading being thus reduced to an absolute minimum, constant attention to the volume control is obviated, especially on the reception of weak and distant stations.

(b) Wave-band or Selector Control.

The Wave-band Control (right-hand knob) is a three-position switch. In its normal position, with the white indicating spot in the vertical centre, the Receiver operates on the Broadcast band, from 200 to 550 metres. With the switch tuned to the left or anti-clockwise position (red spot vertical) the Receiver operates on the short-wave band, from 16 to 40 metres. With the switch turned to the right or clockwise position (green spot vertical) the Receiver operates on the short-wave band, from 40 to 95 metres. See Fig. 1.

The dial is calibrated in three bands to correspond with the foregoing switch positions.

(c) Tone Control.

The lower centre knob is the Tone Control. For normal or "brilliant" reception turn Tone Control to right. Where the background of noise is objectionable (as sometimes occurs on long-distance reception) turn the Tone Control to the left.

For the reception of local or strong interstate stations the Tone Control should be at the "brilliant" position in order that the full range of musical frequencies and overtones may be enjoyed.

SERVICE BULLETIN No. 554 (Continued)

4. VALVES:

All Receivers leaving the factory are equipped with valves inserted into the sockets. If for any reason it becomes necessary to remove the valves, care should be taken to see that each one is replaced in the socket from which it was taken. The photograph of the chassis on page 1 shows the type and function of the valves and their exact location.

Function of Valve.	Type of Valve.
Pentagrid Converter	6A7
First I.F. and First Audio	6F7
Second I.F., Demodulator, A.V.C.	6B7
Power Pentode	42
Rectifier	80

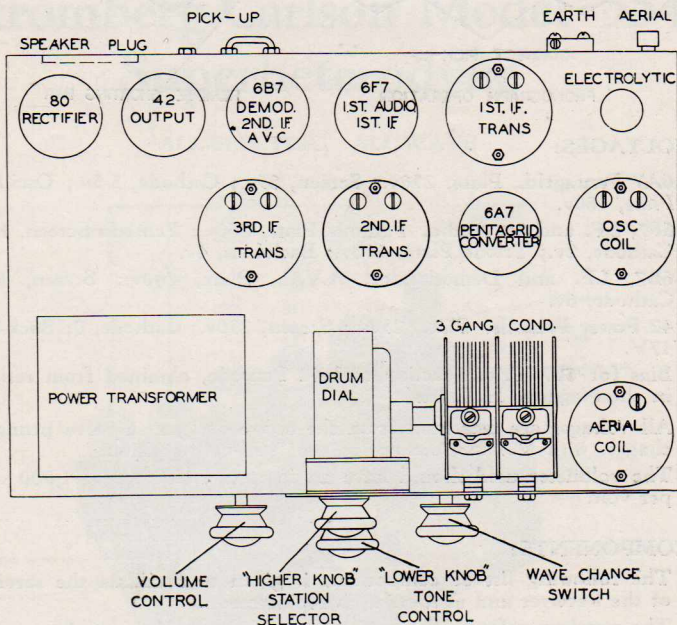

(Diagram showing layout of components.)

5. SPEAKER:

The speaker in this Model is the Dynamic or moving coil type, and is matched to the output valves. The field coil being used at the date of issue of this Bulletin has a resistance of 1,000 ohms. The speaker terminates in a five-pin plug at the Receiver chassis.

THIS PLUG SHOULD NOT BE REMOVED WHILE THE CURRENT IS TURNED ON.

6. PICK-UP JACKS:

Provision is made at the back of the Chassis for the attachment of a Phonograph Pick-up. To operate the pick-up, remove the metal bar between the centre and right-hand jacks and connect the leads from the pick-up to the centre and left-hand jacks, as illustrated.

The metal bar must be replaced when the Receiver is again required for radio operation.

SERVICE BULLETIN No. 554 (Continued)

The Volume Control on the Receiver may be used to regulate the audio output from the pick-up.

Some makes of Magnetic Pick-ups deliver comparatively low voltages, and in such cases, where these are used, an audio transformer of approximately 1-3 ratio should be used between the pick-up and Receiver.

PICK-UP

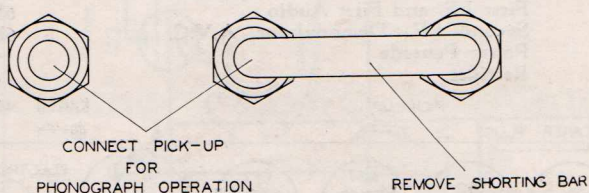

7. VOLTAGES:

6A7 Pentagrid. Plate, 250v.; Screen, 85v.; Cathode, 3-5v.; Oscillator Plate, 180v.

6F7, I.F. and 1st Audio. Pentode Plate, 260v.; Pentode Screen, 85v.; Cathode, 2v.; Triode Plate, 100v.; Back-bias, 4v.

6B7, I.F. and Demodulator, A.V.C. Plate, 260v.; Screen, 85v.; Cathode, 6v.

42 Power Pentode. Plate, 250v.; Screen, 230v.; Cathode, 0; Back-bias, 17V.

Bias for 6F7 Triode section and 42 Pentode, obtained from resistors in the Negative H.T. lead.

All voltages are measured from the above designated valve prongs to chassis, with Volume Control at the "full-on" position.

The voltmeter used should have an internal resistance of 1,000 ohms per volt.

8. COMPONENTS:

The following list of components is given to facilitate the servicing of the Receiver and as a guide to replacements.

The numbers refer to the position of the component on the assembly panel.

- | | |
|--------------------|----------------------|
| 1. .02 microfarad. | 9. .1 microfarad. |
| 2. 100,000 ohms. | 10. 100,000 ohms. |
| 3. .1 microfarad. | 11. .02 microfarad. |
| 4. .1 microfarad. | 12. 70,000 ohms. |
| 5. 1,000 ohms. | 13. .001 microfarad. |
| 6. 300 ohms. | 14. .02 microfarad. |
| 7. 2 megohms. | 15. 8,000 ohms. |
| 8. 1 megohm. | 16. .1 microfarad. |

Capacitor Block: 4 red leads, 0.25 microfarad.
1 yellow lead, 0.5 microfarad.

N.B.—BEFORE LEAVING A STROMBERG-CARLSON RADIO RECEIVER IN A CUSTOMER'S HOME, SEE THAT EVERYBODY WHO IS LIKELY TO HANDLE THE RECEIVER FULLY UNDERSTANDS ITS OPERATION. BY SO DOING MANY UNNECESSARY SERVICE CALLS WILL BE AVOIDED.

Stromberg-Carlson

STROMBERG-CARLSON
SERVICE BULLETIN No. 564

Stromberg-Carlson Model 564 Superheterodyne

ALL-ELECTRIC, ALL-WAVE
FOUR VALVES AND RECTIFIER

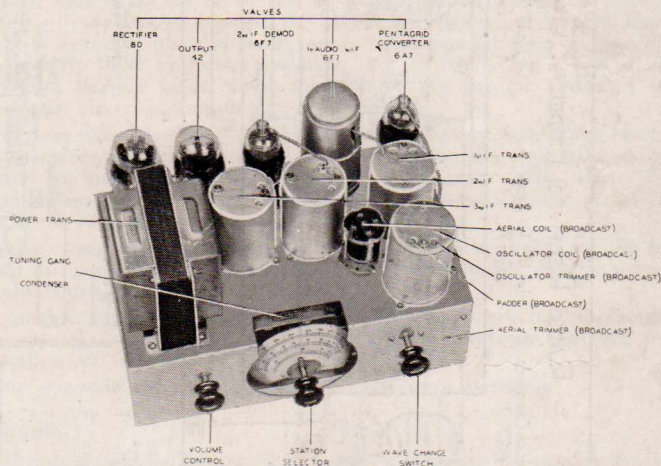

Chassis of 564 Model

This Service Bulletin is issued free of charge to all authorised Stromberg-Carlson Dealers. Applications for additional copies should be made direct to the nearest Distributor.

Stromberg-Carlson (Australasia) Ltd. reserves the right to make changes in design details at any time without incurring any obligations to install same on radio receivers previously sold.

Stromberg-Carlson Model 564 Superheterodyne

ALL-ELECTRIC, ALL-WAVE FOUR VALVES AND RECTIFIER

1. GENERAL DESCRIPTION OF RECEIVER:

This model employs the latest superheterodyne principles and, in addition, incorporates the short-wave spectrums, 16 to 95 metres.

By means of a special circuit, developed by the Stromberg-Carlson (Australasia) Limited Laboratories, it is now possible to offer a receiver having 7-valve performance, within the compass of 5 valves.

This new development employs the latest dual-purpose valves, the 6A7, and 6F7. This circuit must not be confused with the Reflex principle and its attendant limitations.

The Model 564 offers, therefore, a combined broadcast and short-wave receiver and quality reproduction, possible only by means of the most up-to-date components and efficiently designed circuits.

2. INSTALLATION INSTRUCTIONS:

(a) Aerial.

The sensitivity of this model is such that in most installations a well-insulated wire about 20 to 30 feet in length, placed along the picture moulding in a room, or beneath the carpet, will prove satisfactory. Care should be taken to place all such indoor aerials as far away as possible from electric light or power conduits, and in particular, clear of all unshielded flexible leads, since these latter are prolific radiators of undesirable electrical impulses.

An outdoor aerial is the most efficient, especially for short-wave reception, therefore this type of aerial is to be preferred—especially where facilities for such are readily obtainable. In country areas, where the maximum receptivity of the receiver is desired, an outdoor aerial of from 30 to 50 feet in length is recommended.

In noisy areas (due to electrical interference) the aerial should be erected as far as possible from and at right angles to any electric power or light mains.

As a further precaution against undesirable pick-up, the lead-in should be a special "transposed" type, details of which may be had on application to Stromberg-Carlson (Australasia) Ltd.

Do not use shielded lead-in wire for short-wave reception.

(b) Earth.

The chassis should be connected to earth by means of an insulated wire attached to a water pipe by an approved clamp. It is preferable to connect the earth lead to the last section of the pipe where it enters the ground, thus avoiding the high resistance contacts at the joints. Should a water system not be available, an efficient earth may be obtained by driving a metal pipe or burying about four square feet of metal sheeting in moist earth; the connection to the metal should preferably be soldered.

(c) Voltage Adjustment Panel.

Before leaving the factory the power lead is connected to the 240-volt tapping on the power transformer. If the line voltage differs from this the power lead should be unsoldered from the 240-volt tapping and soldered to the tapping which is marked with the voltage nearest to, but not less than, the measured line voltage in the locality. The voltage

SERVICE BULLETIN No. 564 (Continued)

Page 4

tappings for 200, 220, 240, 260 volts are designated on the power transformer.

When making any adjustment, see that the power plug is completely removed from the socket of the supply source.

(d) Trimmer Adjustments.

The tuning adjustments on the gang capacitor (the variable gang tuning condenser) and the trimmer capacitors on the Intermediate Frequency Transformers (tuned to 465 k.c.) are adjusted and sealed at the factory at the time of calibration. These adjustments should on no account be touched or the seals broken unless a specially calibrated oscillator and indicating instrument are available whereby such adjustments can be successfully carried out. In any repairs or adjustments the above remarks in regard to the gang capacitor and intermediate transformers should be carefully noted.

3. WAVE-BAND OR SELECTOR CONTROL:

The Wave-band Control (right-hand knob) is a three-position switch. In its normal position, with the white indicating spot in the vertical centre, the Receiver operates on the Broadcast band, from 200 to 550 metres. With the switch tuned to the left or anti-clockwise position (red spot vertical) the Receiver operates on the short-wave band, from 16 to 40 metres. With the switch turned to the right or clockwise position (green spot vertical) the Receiver operates on the short-wave band, from 40 to 95 metres.

The dial is calibrated in three bands to correspond with the foregoing switch positions.

4. VOLTAGES:

Valve	Function	Cathode	Screen	Plate
6A7 Pent.	Pent. Converter	2-22*	60-80*	155
.. Triode..	—	—	—	155
6F7 Pent.	1st I.F.	1-21*	60-80*	250
.. Triode..	1st A.F.	—	—	90
6F7 Pent.	2nd I.F.	1-21*	60-80*	250
.. Triode..	Demodulator	—	—	—
42 ..	Output	—	250	240
80 ..	Rectifier	—	—	—

All voltages measured with volume control full on, except where marked with an asterisk; voltages so designated are measured with volume control in the "off" position.

Voltage developed across bias resistor in negative lead, 17.5 volts.

5 COMPONENTS:

The following list of components is given to facilitate the servicing of the Receiver and as a guide to replacements.

The numbers refer to the position of the component on the assembly panel.

- | | |
|----------------------|----------------------|
| 1. .1 microfarad. | 8. .1 microfarad. |
| 2. 200 ohms. | 9. .001 microfarad. |
| 3. .5 microfarad. | 10. 70.000 ohms. |
| 4. .0001 microfarad. | 11. .02 microfarad. |
| 5. 100,000 ohms | 12. .5 megohm. |
| 6. .1 microfarad. | 13. 350 ohms. |
| 7. .5 microfarad. | 14. .004 microfarad. |

N.B.—BEFORE LEAVING A STROMBERG-CARLSON RADIO RECEIVER IN A CUSTOMER'S HOME, SEE THAT EVERYBODY WHO IS LIKELY TO HANDLE THE RECEIVER FULLY UNDERSTANDS ITS OPERATION. BY SO DOING MANY UNNECESSARY SERVICE CALLS WILL BE AVOIDED.

Stromberg-Carlson

SERVICE BULLETIN No. 572

Page 1

Model 572 "Roamer" Radio Receiver for Automobiles and Motor-Boats

BATTERY-OPERATED, SUPERHETERODYNE, FIVE VALVES.

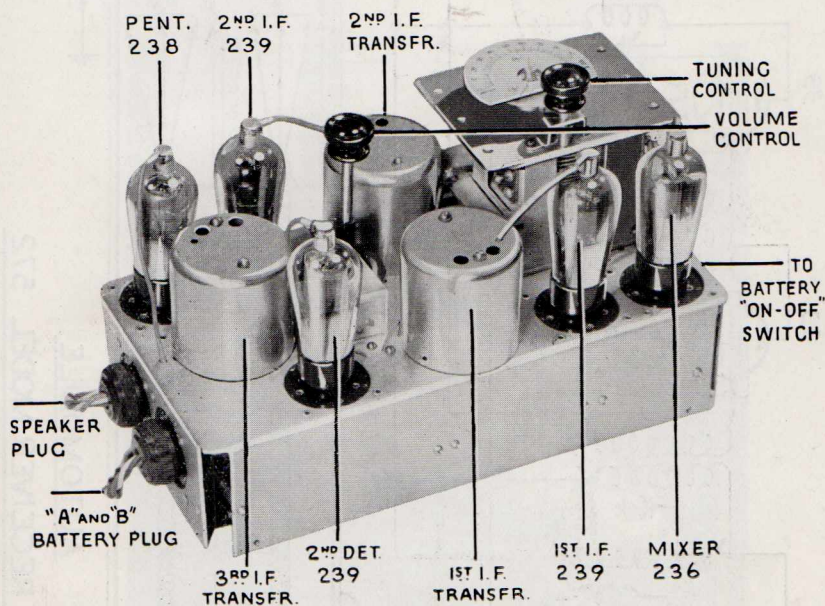

Chassis of Model 572

This Service Bulletin is issued free of charge. Applications for additional copies should be made direct to Stromberg-Carlson (Australasia) Limited, 72-76 William Street, Sydney, New South Wales.

CHANGES

Drawn **M.S.**
 Examined **S.P.C.**
 Approved _____
 Director
 Date **8-10-'32**

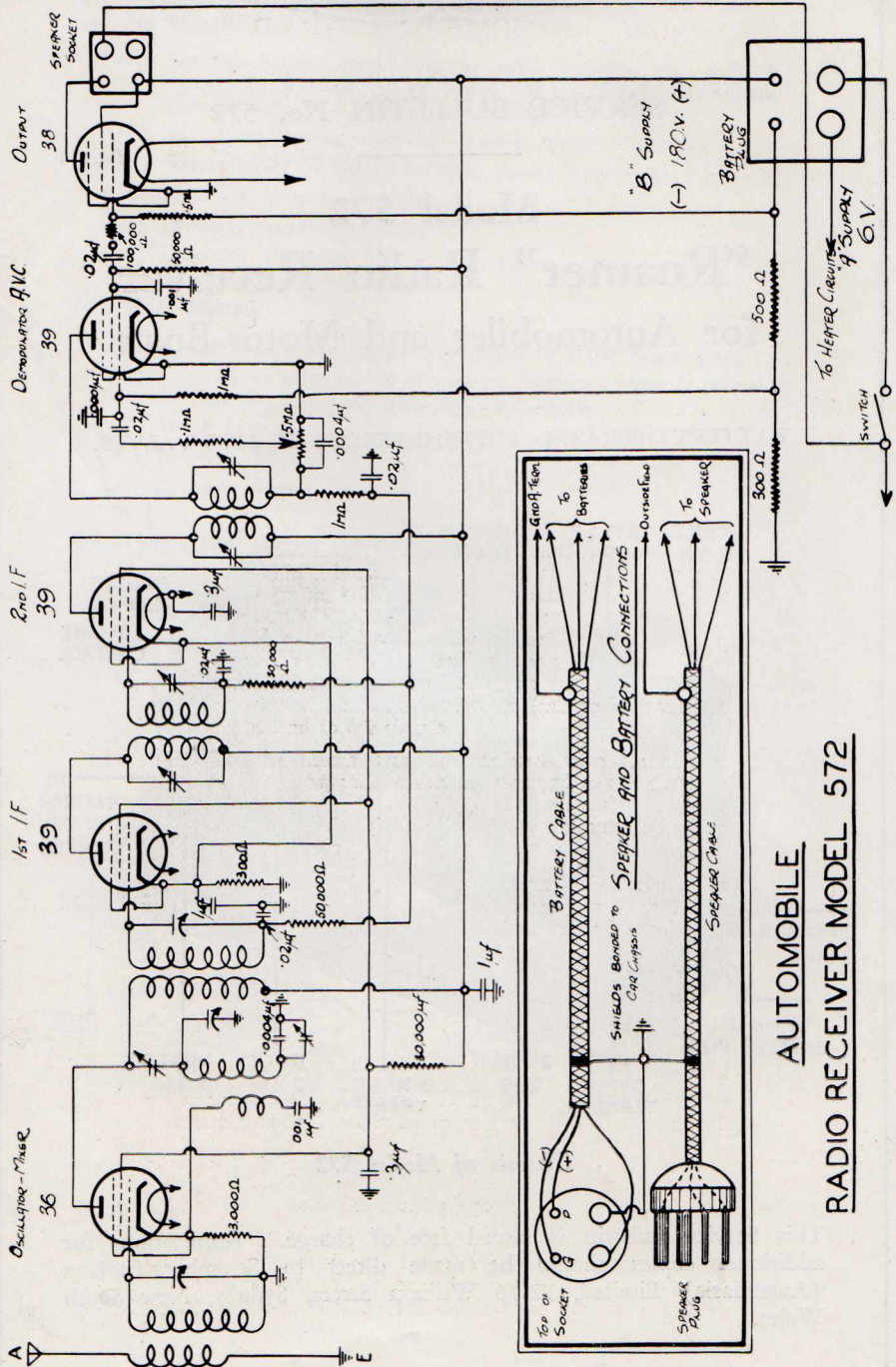

AUTOMOBILE
RADIO RECEIVER MODEL 572

Stromberg-Carlson "Roamer" Radio Receiver for Automobiles and Motor-Boats

BATTERY-OPERATED, SUPERHETERODYNE, FIVE VALVES.

This Receiver is designed specially for use in automobiles, taxis, omnibuses and motor-boats. It incorporates the well-known superheterodyne principle and is provided with Automatic Volume Control to obviate continual attention to the manually-operated volume control which would otherwise be necessary under the rapidly changing conditions of radio reception during journeys from one place to another.

1. GENERAL INSTALLATION INSTRUCTIONS:—

The correct installation of the Receiver is of the utmost importance. Every care should be taken to see that the instructions given in this Service Manual are closely followed, otherwise unsatisfactory results will be obtained.



STROMBERG - CARLSON

Page 4

SERVICE BULLETIN No. 572 (Continued)

(a) Placement of Receiver.

The Receiver is designed in compact form and is totally enclosed in a metal case of such proportions that it may easily be placed in a position that no interference is caused with the car carrying capacity or leg-room. In the majority of motor-cars the most convenient spot is on the floor board between the front seat and the gear-change unit, as shown in the illustration on page 3. In this position it may be affixed to the floor by the special angle-brackets which are already welded to the sides of the metal cabinet.

If, however, this location is not suitable, there are numerous other positions which will suggest themselves when the design of the particular motor-car is examined.

(b) Aerial.

There are numerous methods of installing the aerial, but each type and make of motor-car should be treated according to its mechanical structure. The three following methods have been found satisfactory:—

- (i.) Three to six square feet of fine mesh copper gauze inserted between the tonneau cloth and the wooden ribs of the car roof. In this case, care should be taken to see that no part of the gauze can get into contact with the metal portions of the car body. The aerial lead should be insulated flexible wire shielded with copper braid, should be soldered to the metal gauze, and brought down one of the upright channel ribs to the receiver. It is important that the copper braided shield of the lead be bonded to the car chassis at some convenient place. Before replacing the tonneau cloth, test for continuity between the gauze and the aerial lead, also see that there is no contact or leakage between aerial and aerial lead to car chassis.
- (ii.) Ten to fifteen feet of insulated wire threaded through insulated supports which are clamped to the chassis beneath the floor boards. As in (i), the lead from the aerial proper must be of the shielded type and the outside braiding must be bonded to the car chassis.
- (iii.) An aerial which is supported by stand-off insulators on top of the tonneau, as shown in the diagram on Page 5. It should be erected about 3 to 4 inches high and should consist of one single turn, looped around three sides of the car. The lead-in through the tonneau and the insulators should be arranged with cemented rubber bushings to render them watertight. The lead-in should be shielded.

(c) Lay-out of Components.

For the lay-out of components appearing on top of the chassis, reference should be made to the photograph on Page 1.

(d) Elimination of Interference.

- (i.) Thoroughly clean the spark plugs and if any are old or burned, replace them.
- (ii.) Check up the air-gap between the distributor rotor and the brush contacts; this should be about four thousandths of an inch. Where brush-type distributors are used see that the contact blocks and brushes are clean, and contact surfaces smooth.

STROMBERG - CARLSON

Page 5

SERVICE BULLETIN No. 572 (Continued)

- (iii.) See that the brushes and commutator on the generator are clean and that they have smooth bearing surfaces so that sparking at this point is reduced to a minimum.
Having checked and rectified where necessary the foregoing, fit the suppressors (supplied with each receiver), one each on to each spark-plug terminal and one on to the centre or common lead from the distributor head.
Switch on the receiver at the "on-off" switch, turn volume control full on, and set the tuning-control in such a position that it does not bring in a station, and start car engine. If the interference is still excessive, proceed as follows:—
- (iv.) By-pass with a 1-microfarad condenser either side of the ammeter to frame.
- (v.) By-pass the leads on the generator to frame.
- (vi.) Pipe lines and controls coming in from the engine compartment often carry interference. Placing one hand on the aerial terminal of the receiver (with aerial disconnected) and the other hand under the instrument panel, is a good method of finding the offending unit. A great increase in noise when the hand is near a radiating unit will indicate the source. Bond all such units to frame.
- (vii.) Reversing the low tension leads to the transformer ignition coil often reduces interference.
- (viii.) Where the ignition coil is mounted on the instrument panel, shield the coil and leads through to the engine compartment.
- (ix.) Shield the high-tension lead from the coil to the distributor-head and, in some cases, the low-tension lead from the coil to the breaker.
- (x.) Where a roof antenna is used, it may be necessary either to place a small choke in series with the dome-light circuit or insert a switch so that the circuit is disconnected when the receiver is in operation. By-passing this circuit may also prove effective.
- (xi.) In special cases, where the interference is coming in over the battery leads, a small choke consisting of 20 turns of No. 18 cotton-covered wire, wound on a wooden former of about 3-inch diameter, placed in series with the "high" side of the "A" battery, will cure the trouble.

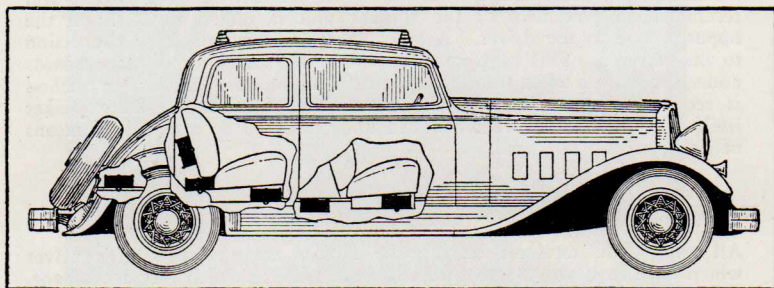

Diagram shows various positions which may conveniently house the "B" Batteries or "B" Battery Eliminator. The aerial on top of tonneau is as described in 1 (b) (iii.).

STROMBERG - CARLSON

Page 6

SERVICE BULLETIN No. 572 (Continued)

2. BATTERIES:—

- (i.) "A" Battery.—The receiver is designed to operate from the 6-volt car battery. The grounded polarity of a car battery differs in the various makes, some being grounded at the positive pole, others at the negative pole.

The "A" battery lead from the receiver is of the shielded type. The inner and insulated lead should be joined to the ungrounded pole of the car battery whilst the outer shield should be connected to the grounded pole.

- (ii.) "B" Batteries.—The receiver is designed to operate from 180 volts with a total drain of 20 milliamps. Four blocks of 45 volt "B" batteries connected in series and connected as per diagram, will automatically supply both "B" and "C" voltages to the receiver in the correct proportion.

The placement of the batteries is mostly a matter of convenience, and the diagram on Page 5 shows the various positions in a car which may conveniently house the batteries.

The leads from the batteries to the receiver are to be of the shielded type and the cable shielding should be electrically bonded to the car chassis.

- (iii.) Fuses are supplied with battery cables, one in the "A" battery and one in the "B" battery cable. These fuses should be placed as close to their respective batteries as possible, and are a protection against short circuits in the receiver, components or cables themselves. Should one of these fuses "blow," the cause should be ascertained before it is replaced. The fuses are housed in an insulated rod and can be removed by unscrewing knurled end section.

Note.—Approved battery eliminators which are capable of supplying 180 volts and 20 m.a., may be used instead of the "B" batteries. Such units must be housed in watertight and electrically shielded cases, and, as in the case of batteries, all leads must be shielded and the shield electrically bonded to the car chassis.

3. LOUD-SPEAKER.

The speaker is a specially designed dynamic type for automobile receivers, the field of which operates from the 6-volt car battery. The logical and recommended placement of the speaker unit is under the dash on the opposite side to the driver. A shielded cable is supplied for connection to the receiver. This cable may be run in a channel in the floor boards under the mat or taken through and below the boards. The former method is recommended, as it keeps the cable clear of moisture. The speaker itself is housed in a special wooden unit, ready to be attached by means of bolts, to the bulkhead.

4. VALVES.

All automobile receivers leaving the factory are equipped with valves which have been tested and matched to the receiver which they accompany. The photograph on Page 1 shows the exact location of the valves, whilst the schedule given on Page 7 shows their type and function.

The valves used are of the six-volt type, and on account of their mechanical robustness are ideally adapted to withstand vibration.

STROMBERG - CARLSON

SERVICE BULLETIN No. 572 (Continued)

Function of Valve.	Type of Valve.
Oscillator-Mixer	236
1st I.F.	239
2nd I.F.	239
Detector and A.V.C.	239
Output Pentode	238

5. OPERATION.

To facilitate operation, the Controls are located upon the top of the receiver and consist of Volume and Tuning Controls only. Both the driver and the front-seat passenger can tune-in without inspecting the tuning-dial if necessary.

The Battery "On-Off" Switch is located at the side of the receiver in a convenient position.

6. VOLTAGES.

All voltages given in the table below are those which should be obtained when using a 0-60-120-300 volt voltmeter having a resistance of 1,000 ohms per volt. Voltages shown below 60 are to be read on the 0-60 scale, those below 120 on the 0-120 scale, and those above 120 on the 0-300 scale. It is important to note that other voltmeters having different internal resistances will give voltage readings different from those mentioned in the following table. Therefore a 1,000 ohm per volt voltmeter should be used.

VOLTAGES — With 180 Volts Total Supply.

Valve	Filament.	Plate Volts	Screen Volts	Bias	Plate Current
Oscillator- Mixer 236	6.0	165	85	5	1.5 m.a.
I.F. 239	6.0	165	85	3 (min.)	4.0 m.a.
I.F. 239	6.0	165	85	3 (min.)	4.0 m.a.
Det. A.V.C. 239	6.0	80 (Screen Terminal)	—	7	1.6 m.a.
Pentode 238	6.0	165	160	17	8.5 m.a.

STROMBERG - CARLSON

Page 8

SERVICE BULLETIN No. 572 (Continued)

7. FAULTS.

(a) No Signals.

- (i.) Examine battery connections to receiver, check "A" and "B" voltages at receiver end of cables. If test shows "no voltage" examine fuses and battery connections.
- (ii.) Battery or speaker plugs not making proper contact.
- (iii.) Valves faulty or failing to make contact in sockets.
- (iv.) Defective by-pass condenser.
- (v.) Defective resistor.
- (vi.) Defective oscillator, R.F. or I.F. coils.

(b) Weak Signals.

- (i.) Aerial trimmer not properly adjusted to aerial being used.
- (ii.) Trimmer or gang out of adjustment (access to these is provided by removing the name plate on outer case).
- (iii.) Weak batteries.
- (iv.) Defective Speaker.
- (v.) Defective Valves.

(c) Noise (from sources other than car ignition).

- (i.) Aerial making intermittent contact with metal portions of car.
- (ii.) Defective valves or loose valve sockets.
- (iii.) Defective resistors, or units touching metal frame of receiver.
- (iv.) Defective battery connections, or loose bonding to car chassis.
- (v.) Loose or high resistance joints.

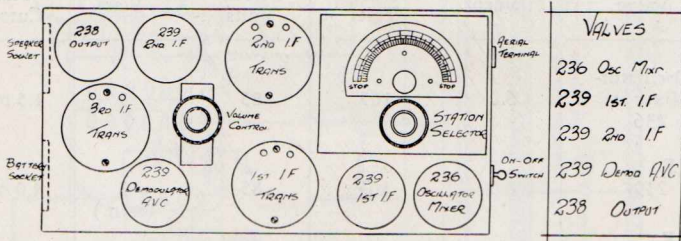

Stromberg-Carlson

STROMBERG-CARLSON
SERVICE BULLETIN No. 574

Stromberg-Carlson Model 574 Superheterodyne

ALL ELECTRIC FOUR VALVES AND RECTIFIER

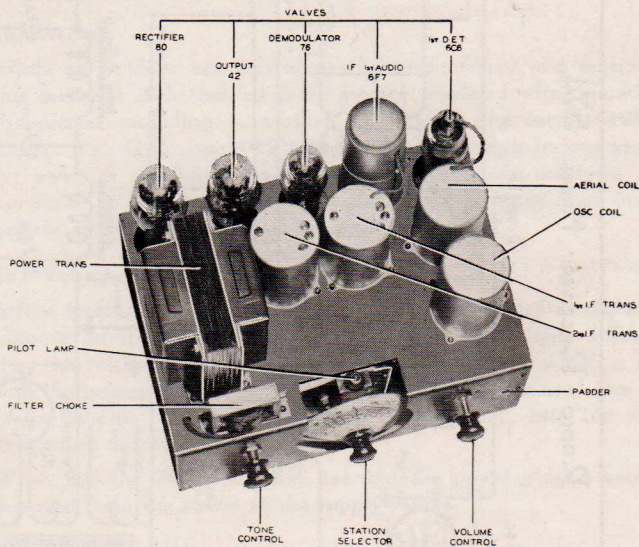

Chassis of Model 574

This Service Bulletin is issued free of charge to all authorised Stromberg-Carlson Dealers. Applications for additional copies should be made direct to the nearest Distributor.

Stromberg-Carlson (Australasia) Ltd. reserves the right to make changes in design details at any time without incurring any obligations to install same on radio receivers previously sold.

Hromberg-Carlson (Australasia) Limited
 Sydney - Australasia

Drawing No Z227

CHANGES

Drawn J.W.S.
 Examined [Signature]
 Approved [Signature]
 Mgr./Director

DATE 22-5-34

RADIO RECEIVER MODEL 574

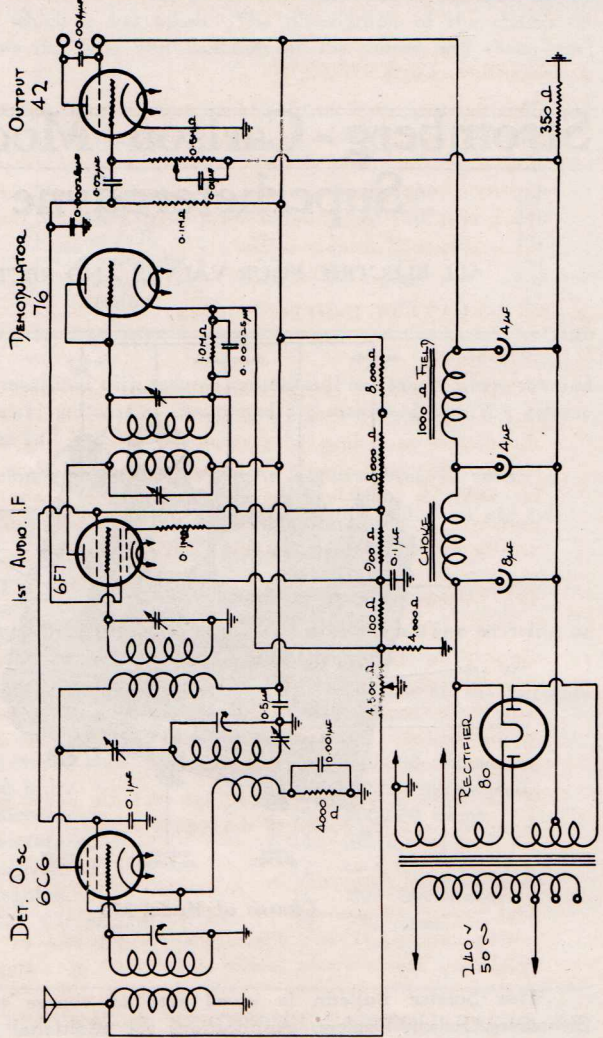

Stromberg-Carlson Model 574 Superheterodyne

ALL ELECTRIC FOUR VALVES AND RECTIFIER

1. GENERAL DESCRIPTION:

This receiver employs the latest superheterodyne circuit design and takes advantage of the new multi-purpose valves. The new pentode is also employed. This design results in a still further advance in the quality of reproduction. In order to obtain correct acoustical balance, much care and forethought have been expended upon the design of the cabinet and speaker baffle.

2. INSTALLATION INSTRUCTIONS:

(a) Aerial.

While an outdoor aerial is always to be preferred, the sensitivity of this model is such that 20 to 30 feet of insulated wire, placed along the picture moulding in a room, or beneath the carpet, will prove satisfactory. Care should be taken to place all such indoor aerials as far away as possible from electric light or power conduits, and in particular, clear of all unshielded flexible leads, since these latter are prolific radiators of undesirable electrical impulses.

(b) Voltage Adjustment Panel.

Before leaving the factory the power lead is connected to the 240 volt tapping on the power transformer. If the line voltage differs from this, the voltage switch should be adjusted to the tap which is marked with the voltage nearest to, but not less than, the measured line voltage in the locality. The voltage tappings for 200, 220, 240, 260 volts are designated on the power transformer.

When making any adjustment, see that the power plug is completely removed from the socket of the supply source.

(c) Trimmer Adjustments.

The tuning adjustments on the gang capacitor (the variable gang tuning condenser) and the trimmer capacitors on the Intermediate Frequency Transformers (tuned to 465 k.c.) are adjusted at the factory at the time of calibration. These adjustments should on no account be touched unless a specially calibrated oscillator and indicating instrument are available whereby such adjustments can be successfully carried out. In any repairs or adjustments the above remarks in regard to the gang capacitor and intermediate transformers should be carefully noted.

SERVICE BULLETIN No. 574 (Continued)

Page 4

3. VOLTAGES:

All Receivers leaving the factory are equipped with valves inserted into the sockets. If for any reason it becomes necessary to remove the valves, care should be taken to see that each one is replaced in the socket from which it was taken. The photograph of the chassis on Page 1 shows the type and function of the valves and their exact location.

Valve	Function	Cathode	Screen	Plate
6C6	Pent. Converter	4	85-110*	240
6F7	Pent. 1st I.F.	2-25*	85-110*	240
"	Triode 1st A.F.	—	—	90
76	Demodulator	—	—	—
42	Output	—	240	230
80	Rectifier	—	—	—

All voltages measured with volume control full on, except where marked with an asterisk; voltages so designated are measured with the volume control in the full "off" position.

Voltage developed across bias resistor in negative lead, 17 volts.

The voltmeter used should have a resistance of 1,000 ohms per volt.

4. COMPONENTS:

The following list of components is given to facilitate the servicing of the Receiver and as a guide to replacements.

The numbers refer to the position of the component on the assembly panel.

- | | |
|-----------------------|-----------------------|
| 1. .001 microfarad. | 8. 100,000 ohms. |
| 2. 5,000 ohms. | 9. .00025 microfarad. |
| 3. .5 microfarad. | 10. 100,000 ohms. |
| 4. .1 microfarad. | 11. .02 microfarad. |
| 5. .1 microfarad. | 12. — |
| 6. 1 megohm. | 13. .004 microfarad. |
| 7. .00025 microfarad. | 14. 350 ohms. |

N.B.—BEFORE LEAVING A STROMBERG-CARLSON RADIO RECEIVER IN A CUSTOMER'S HOME, SEE THAT EVERYBODY WHO IS LIKELY TO HANDLE THE RECEIVER FULLY UNDERSTANDS ITS OPERATION. BY SO DOING MANY UNNECESSARY SERVICE CALLS WILL BE AVOIDED.

Stromberg-Carlson

STROMBERG-CARLSON
SERVICE BULLETIN No. 584

Stromberg-Carlson Model 584 UNIVERSAL A.C.-D.C. Superheterodyne

ALL ELECTRIC FOUR VALVES AND RECTIFIER

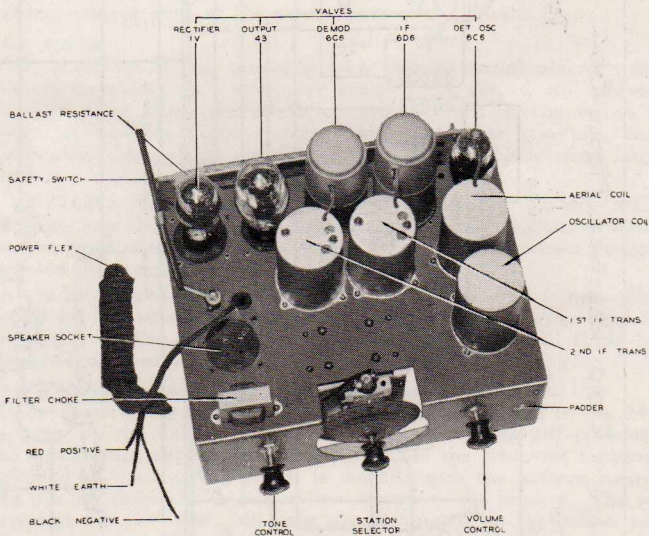

Chassis of Model 584

This Service Bulletin is issued free of charge to all authorised Stromberg-Carlson Dealers. Applications for additional copies should be made direct to the nearest Distributor.

Stromberg-Carlson (Australasia) Ltd. reserves the right to make changes in design details at any time without incurring any obligations to install same on radio receivers previously sold.

SERVICE BULLETIN No. 584 (Continued)

Page 3

Stromberg-Carlson Model 584

UNIVERSAL A.C.-D.C.

Superheterodyne

ALL ELECTRIC FOUR VALVES AND RECTIFIER

1. GENERAL DESCRIPTION OF RECEIVER:

The Universal A.C.-D.C. Model is particularly adapted to areas where the electric supply is direct current.

A number of such areas are at present in the process of conversion to an alternating current supply. In these circumstances the 584 Receiver is ideal, in that it operates with equal efficiency on either A.C. or D.C. supplies.

2. INSTALLATION INSTRUCTIONS:

(a) Safety.

Every precaution has been taken to render the 584 A.C.-D.C. Receiver perfectly safe. Nevertheless, due care should be exercised in the installation of this type of receiver.

Do not make any adjustments to the receiver, aerial, or any lead connected thereto, without first of all disconnecting the receiver from the supply mains.

As a further protection, the 584 chassis has been fitted with an automatic switch, which—on the removal of the protective back on the cabinet—opens both of the power leads to the chassis.

(b) Aerial.

The sensitivity of this model is such that an aerial placed along the picture moulding in a room, or beneath the carpet, will prove satisfactory. Care should be taken to place all such indoor aerials as far away as possible from electric light or power conduits, and, in particular, clear of all unshielded flexible leads, since these latter are prolific radiators of undesirable electrical impulses.

CAUTION. When an outdoor aerial is installed on any A.C.-D.C. receiver, care should be taken to place the aerial well clear of buildings, and to particularly avoid any possibility of bodily contact being made between the aerial and any metal roofing.

In the Stromberg-Carlson A.C.-D.C. Model the aerial is normally protected by two specially selected condensers. Only on the very remote possibility of the two condensers breaking down would there be any danger from contact with the aerial circuit.

(c) Voltage Adjustment Panel and Power Connections.

Before leaving the factory the power lead is connected to the 240 volt tapping on the ballast resistor. If the line voltage differs from this, the power lead should be unsoldered from the 240 volt tapping and soldered to the tapping which is marked with the voltage nearest to, but not less than, the measured line voltage in the locality. The voltage tappings for 220, 240, 260 volts are designated on the ballast resistor. The three-wire power cable consists of the two power leads, red and black, and an earth lead, white.

When connected to D.C., it is imperative that the RED lead be connected to the POSITIVE and the BLACK to the NEGATIVE of the supply mains. If reversed the filaments will light but the receiver will not operate.

When connected to A.C. it is preferable for the RED lead to be connected to the ACTIVE and the BLACK to the NEUTRAL of the supply mains.

Note.—To ascertain ACTIVE, check with test lamp (240 volt) between line and earth. The ACTIVE will be indicated by the lamp lighting. No light will be observed between NEUTRAL and earth.

When making any adjustment, see that the power plug is completely removed from the socket of the supply source.

SERVICE BULLETIN No. 584 (Continued)

Page 4

(d) Trimmer Adjustments.

The tuning adjustments on the gang capacitor (the variable gang tuning condenser) and the trimmer capacitors on the Intermediate Frequency Transformers (tuned to 465 k.c.) are adjusted at the factory at the time of calibration. These adjustments should on no account be touched unless a specially calibrated oscillator and indicating instrument are available whereby such adjustments can be successfully carried out. In any repairs or adjustments the above remarks in regard to the gang capacitor and intermediate transformers should be carefully noted.

3. VALVES:

All Receivers leaving the factory are equipped with valves inserted into the sockets. If for any reason it becomes necessary to remove the valves, care should be taken to see that each one is replaced in the socket from which it was taken. The photograph of the chassis on Page 1 shows the type and function of the valves and their exact location.

Function of Valve.	Type of Valve.
Oscillator-Mixer	6C6
I.F.	6D6
Detector	6C6
Power Pentode	43
Rectifier	1.V.

4. COMPONENTS:

The following list of components is given to facilitate the servicing of the Receiver and as a guide to replacements.

The numbers refer to the position of the component on the assembly panel.

- | | |
|---------------------|---------------------|
| 1. .001 microfarad. | 9. 200,000 ohms. |
| 2. 5000 ohms. | 10. 100,000 ohms. |
| 3. 15,000 ohms. | 11. .02 microfarad. |
| 4. 15,000 ohms. | 12. 750 ohms. |
| 5. 200 ohms. | 13. 25 microfarads. |
| 6. 15,000 ohms. | 14. .02 microfarad. |
| 7. 500,000 ohms. | 15. |
| 8. .001 microfarad. | 16. 150 ohms. |

Capacitor block: 4 red leads 0.25 microfarad.
1 yellow lead 0.5 microfarad.

5. VOLTAGES:

Valve.	Screen.	Plate.	Cathode.
Det.-Osc. 6C6	65, 85*	155	5
I.F. 6D6	65, 85*	155	2, 35*
2nd Det. 6C6	20	50	3
Output 43	150	150	20

All voltages are measured from the above designated valve prongs to the common negative bus, with volume control at full "on" position, except those marked with an asterisk, which are measured with the volume control at the "off" position.

The voltmeter used should have a resistance of 1000 ohms per volt.

N.B.—BEFORE LEAVING A STROMBERG-CARLSON RADIO RECEIVER IN A CUSTOMER'S HOME, SEE THAT EVERYBODY WHO IS LIKELY TO HANDLE THE RECEIVER FULLY UNDERSTANDS ITS OPERATION. BY SO DOING MANY UNNECESSARY SERVICE CALLS WILL BE AVOIDED

Stromberg-Carlson

STROMBERG-CARLSON
SERVICE BULLETIN, No. 588

Stromberg-Carlson Model 588 Superheterodyne

DUAL-WAVE BATTERY-OPERATED RECEIVER.

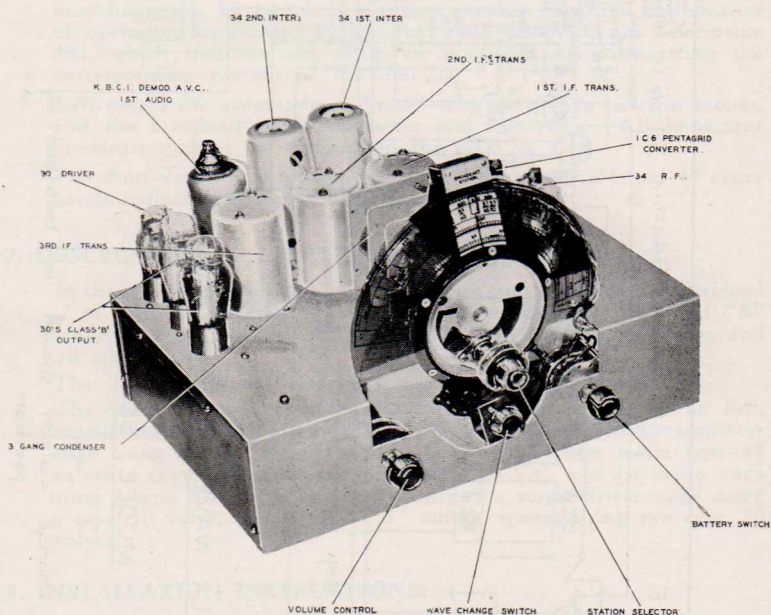

Chassis of Model 588

This Service Bulletin is issued free of charge to all authorised Stromberg-Carlson Dealers. Applications for additional copies should be made direct to the nearest Distributor.

Stromberg-Carlson (Australasia) Ltd. reserves the right to make changes in design details at any time without incurring any obligations to install same on radio receivers previously sold.

STROMBERG-CARLSON (AUSTRALASIA) LIMITED
 SYDNEY, AUSTRALIA

DRAWING No. Z 283

CHANGES

DRAWN *[Signature]*
 EXAMINED *[Signature]*
 APPROVED MGN. DIRECTOR
 DATE 30.1.35

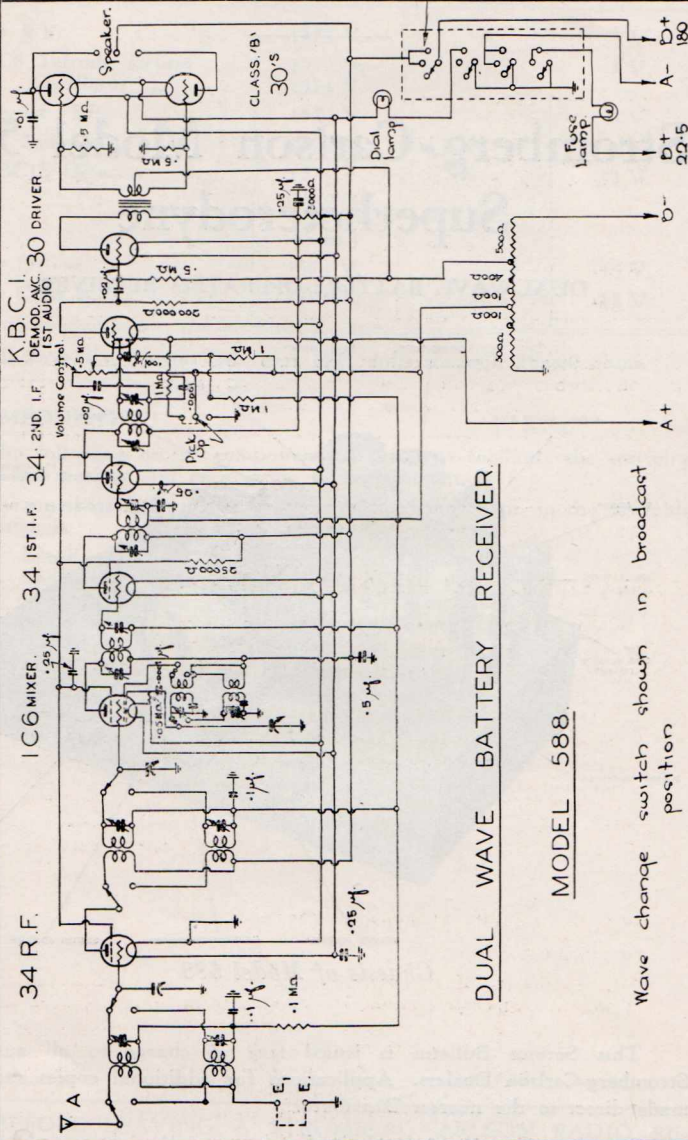

DUAL WAVE BATTERY RECEIVER.

MODEL 588.

Wave change switch shown in broadcast position

Stromberg-Carlson Model 588 Superheterodyne

DUAL-WAVE BATTERY-OPERATED RECEIVER.

1. GENERAL DESCRIPTION OF RECEIVER:

This 8-valve, two-band battery-operated superheterodyne Receiver provides excellent reception of both standard wave and short-wave broadcasting stations. One band is the usual broadcast band from 200 to 500 metres, and the other a short-wave band from 19-53 metres. This latter band includes the four important internationally assigned short-wave broadcast bands at 19, 25, 31 and 49 metres, respectively.

High sensitivity, excellent selectivity, automatic volume control, and good fidelity characterise this receiver. The tuning ranges are quickly interchangeable by means of a rotary switch. Ease and convenience of operation are assured by the dual ratio drive and the Selectorlite dial, which indicates the range in operation by illuminating the corresponding portion of the dial.

Both ranges are accurately calibrated—the short-wave band in metres, and the broadcast band in metres and kilocycles. All important broadcast stations are marked on the dial.

The short-wave range has the location of the 19, 25, 31 and 49 metre bands indicated by heavy black lines.

2. DESCRIPTION OF ELECTRICAL CIRCUIT:

In this model, the valves have been chosen and the circuit so designed as to give the greatest efficiency consistent with low "A" and "B" battery consumption. The eight valves are operated at 2 volts and .58 amperes.

The "B" battery drain is approximately 15 milliamperes.

The circuit is of the superheterodyne type, and consists of an R.F. amplifying stage using a type 34 valve, a combined detector-oscillator stage using a 1C6 valve, two I.F. amplifying stages using type 34 valves, a combined diode second detector, A.V.C. and 1st audio stage using a type KBC1S valve (Philips series) a single driver stage using a type 30 valve, and a class "B" output system using two type 30 valves.

3. INSTALLATION INSTRUCTIONS:

(a) Aerial.

The sensitivity of this model is such that for broadcasting reception a well-insulated wire about 20 or 30 feet in length, placed along the picture moulding in a room, or beneath the carpet, will prove satisfactory. Care should be taken to place all such indoor aerials as far away as possible from electric light or power conduits, and, in particular, clear of all unshielded flexible leads, since these latter are prolific radiators of undesirable electrical impulses.

An outdoor aerial is the most efficient, and is strongly recommended, especially for long-distance daylight reception on the broadcast band. The length of this aerial should be from 30 to 50 feet. In noisy areas (due to electrical interference) the aerial should be erected as far as possible from and at right-angles to any electric power or light mains. As a further precaution against undesirable pick-up, the lead-in should be a special shielded type as employed in the "Stromberg-

Carlson Aerial Noise Eliminator Kit." Details of this type of aerial may be had on application to Stromberg-Carlson (Australasia), Limited.

Do not use shielded lead-in wire for short-wave reception.

(b) Earth.

The chassis should be connected to earth by means of an insulated wire attached to a water pipe by an approved clamp. It is preferable to connect the earth lead to the last section of the pipe where it enters the ground, thus avoiding the high resistance contacts at the joints. Should a water system not be available, an efficient earth may be obtained by driving a metal pipe or burying about four square feet of metal sheeting in moist earth; the connection to the metal should preferably be soldered.

(c) Batteries.

(i) "A" battery.—This consists of a 2-volt 40-60 ampere-hour accumulator.

(ii.) "B" and "C" batteries.—these comprise 4 heavy duty or super 45-volt batteries.

To join the battery leads correctly to the batteries, reference should be made to the designation tabs to the leads and to the colour code, as shown in the circuit diagram on Page 2 hereof.

The four "B" batteries may be housed in the back of the cabinet on the lower shelf—two on the right, and two on the left hand side of the loud-speaker.

The "A" battery may then be placed in between the "B" batteries, or on the floor immediately behind the cabinet.

(d) Trimmer Adjustments.

The trimmer capacitors on the variable condenser, coil assembly, and the trimmer capacitors on the Intermediate Frequency Transformers (tuned to 450 k.c.) are adjusted and sealed at the factory at the time of calibration. These adjustments should on no account be touched or seals broken unless a specially calibrated oscillator and indicating instrument are available, whereby such adjustments can be successfully carried out.

In any repairs or adjustments the above remarks in regard to the coil assembly and intermediate transformer should be carefully noted.

4. OPERATION:

(a) Battery Switch.

A three position operating switch is used. When turned fully to the left, the receiver is switched off; both the "A" and "B" battery supplies being disconnected. When turned fully to the right, the receiver is ready to operate, and a pilot light is switched on. After tuning to the required station, the switch should then be turned to the centre position. This will extinguish the pilot light only, so removing drain from the battery, and the set will operate in the normal manner.

(b) Automatic Volume Control.

This Model is so designed that the signal voltages fed to the audio system, tend to adjust themselves to a constant level. This signal level is manually controlled and should be adjusted to the desired volume on a station of moderate or high power. The automatic feature will then tend to maintain this volume at a constant level on different signals of wide variations in intensity.

The effects of fading being thus reduced to an absolute minimum, constant attention to the volume control is obviated, especially on the reception of weak and distant stations.

SERVICE BULLETIN, No. 588 (Continued)

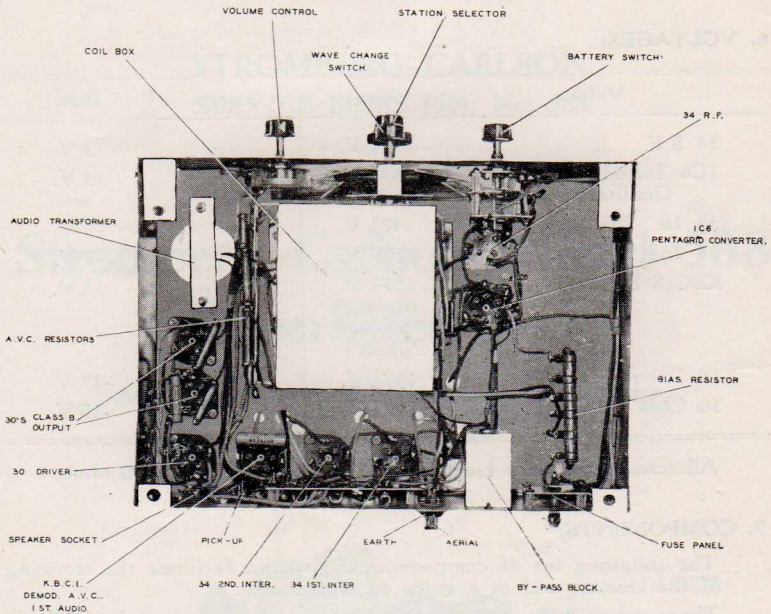

5. PICK-UP JACKS:

Provision is made at the back of the Chassis for the attachment of a Phonograph Pick-up. To operate the pick-up, remove the metal bar between the centre and bottom jacks, and connect the leads from the pick-up to the centre and top jacks, as illustrated.

The metal bar must be replaced when the Receiver is again required for radio operation.

The Volume Control on the Receiver may be used to regulate the audio output from the pick-up.

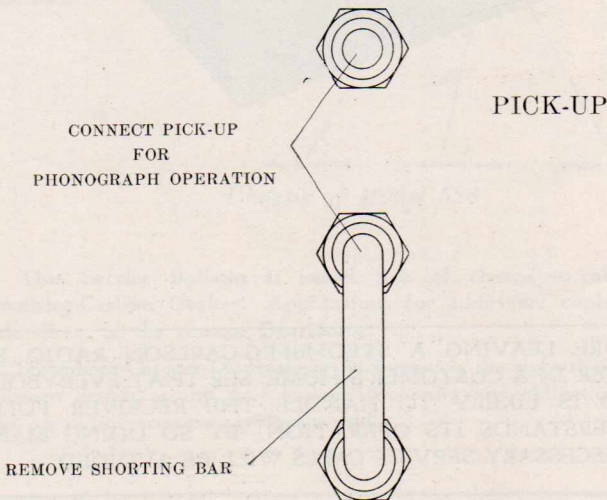

SERVICE BULLETIN, No. 588 (Continued)

6. VOLTAGES:

Valve.	Plate.	Screen.	Bias.
34 R.F.	157½ V.	—	-3 V.
1C6 Tetrode section ..	157½ V.	—	-3 V.
Oscillator „ ..	157½ V.	—	—
34 1st I.F.	157½ V.	—	-3 V.
34 2nd I.F.	157½ V.	—	-3 V.
KBC1S Detector	157½ V. (through 200,000 ohms.)	—	-3 V.
30 Driver	157½ V.	—	-15 V.
30 Class B.	157½ V.	—	-15 V.

All screens are series fed from 157½ volts through 25,000 ohms.

7. COMPONENTS.

The following list of components is given to facilitate the servicing of the receiver and as a guide to replacement.

The numbers refer to the position of the component on the assembly panel.

- | | |
|-----------------|------------------|
| 1. Blank. | 6. 200,000 ohms. |
| 2. 25,000 ohms. | 7. .02 mf. |
| 3. 1 megohm. | 8. ½ megohm. |
| 4. .0001 mf. | 9. Blank. |
| 5. .02 mf. | |

N.B.—BEFORE LEAVING A STROMBERG-CARLSON RADIO RECEIVER IN A CUSTOMER'S HOME, SEE THAT EVERYBODY WHO IS LIKELY TO HANDLE THE RECEIVER FULLY UNDERSTANDS ITS OPERATION. BY SO DOING MANY UNNECESSARY SERVICE CALLS WILL BE AVOIDED.

Stromberg-Carlson

STROMBERG-CARLSON
SERVICE BULLETIN No. 604

Stromberg-Carlson Model 604 Superheterodyne

ALL-WAVE, BATTERY-OPERATED
RADIO RECEIVER

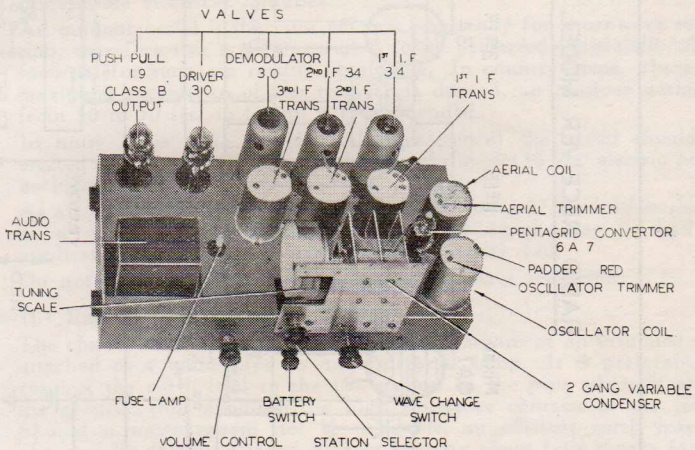

Chassis of 604 Model

This Service Bulletin is issued free of charge to all authorised Stromberg-Carlson Dealers. Applications for additional copies should be made direct to the nearest Distributor.

Stromberg-Carlson (Australasia) Ltd. reserves the right to make changes in design details at any time without incurring any obligations to install same on radio receivers previously sold.

Stromberg-Carlson Model 604

ALL-WAVE, BATTERY-OPERATED RECEIVER

1. GENERAL DESCRIPTION OF RECEIVER:

This Model employs the latest superheterodyne principles, and has been primarily designed as a high-quality battery-operated Receiver. In accordance with the Stromberg-Carlson policy of making available to the public the achievements of the foremost radio laboratories, the Model 604 incorporates the short-wave spectrums.

In this model, the valves have been chosen and the circuit so designed to give the greatest efficiency consistent with low "A" and "B" battery consumption. The six valves are operated at 6 volts and 0.62 ampere. The "B" battery drain is approximately 15 milliamperes.

The Model 604 offers, therefore, a broadcast receiver of outstanding quality, performance and economy with the additional features of a most efficient short-wave receiver.

2. INSTALLATION INSTRUCTIONS:

(a) Aerial.

The sensitivity of this model is such that in most installations a well-insulated wire about 20 to 30 feet in length, placed along the picture moulding in a room, or beneath the carpet, will prove satisfactory. Care should be taken to place all such indoor aerials as far away as possible from electric light or power conduits, and in particular, clear of all unshielded flexible leads, since these latter are prolific radiators of undesirable electrical impulses.

An outdoor aerial is the most efficient, especially for short-wave reception, therefore this type of aerial is to be preferred—especially where facilities for such are readily obtainable. In country areas, where the maximum receptivity of the receiver is desired, an outdoor aerial of from 30 to 50 feet in length is recommended.

In noisy areas (due to electrical interference) the aerial should be erected as far as possible from and at right angles to any electric power or light mains.

As a further precaution against undesirable pick-up, the lead-in should be a special "transposed" type, details of which may be had on application to Stromberg-Carlson (Australasia) Ltd.

Do not use shielded lead-in wire for short-wave reception.

(b) Earth.

The chassis should be connected to earth by means of an insulated wire attached to a water pipe by an approved clamp. It is preferable to connect the earth lead to the last section of the pipe where it enters the ground, thus avoiding the high resistance contacts at the joints. Should a water system not be available, an efficient earth may be obtained by driving a metal pipe or burying about four square feet of metal sheeting in moist earth; the connection to the metal should be soldered.

(c) Batteries.

(i) A Battery.—This consists of a 6 volt, 80-100 ampere-hour accumulator.

(ii) B and C Batteries.—These comprise 4 heavy duty or Super 45 volt batteries.

To join the battery leads correctly to the batteries, reference should be made to the designation tabs on the leads, and to the colour code, as shown in the circuit diagram on page 2.

The four B batteries may be housed in the back of the cabinet on the lower shelf, two on the right and two on the left-hand side of the loud speaker. The A battery may then be placed in between the B batteries or on the floor immediately behind the cabinet.

(d) Trimmer Adjustments.

The tuning adjustments on the gang capacitor (the variable gang tuning condenser) and the trimmer capacitors on the Intermediate Frequency Transformers (tuned to 465 k.c.) are adjusted and sealed at the factory at the time of calibration. These adjustments should on no account be touched or the seals broken unless a specially calibrated oscillator and indicating instrument are available whereby such adjustments can be successfully carried out. In any repairs or adjustments the above remarks in regard to the gang capacitor and intermediate transformers should be carefully noted.

(e) Wave-band or Selector Control.

The Wave-band Control (right-hand knob) is a three-position switch. In its normal position, with the white indicating spot in the vertical centre, the Receiver operates on the Broadcast band, from 200 to 550 metres. With the switch tuned to the left or anti-clockwise position (red spot vertical) the Receiver operates on the short-wave band, from 16 to 40 metres. With the switch turned to the right or clockwise position (green spot vertical) the Receiver operates on the short-wave band, from 40 to 95 metres.

The dial is calibrated in three bands to correspond with the foregoing switch positions.

3. VALVES AND VOLTAGES.

6A7 Pentagrid Converter, plate 157 volts, screen 67 volts, oscillator plate 157 volts, filament 6 volts.

34 I.F. (two stages), plates 157 volts, screen 67 volts, filament 2 volts.

30 Demodulator, plate 60 volts, filament 2 volts.

30 A.F. Driver, plate 157 volts, filament 2 volts.

19 "Class B" Push-pull Output, plates 157 volts, filament 2 volts.

The bias voltages are measured on the Potential Divider, Demodulator —10.5 volts, A.F. Driver —8.5 volts. Output —6 volts.

Variable bias, measured at volume control —2 to —22.5 volts.

The voltmeter used should have a resistance of 1,000 ohms per volt.

4. COMPONENTS.

The following list of components is given to facilitate the servicing of the Receiver and as a guide to replacements.

The numbers refer to the position of the component on the assembly panel.

- | | |
|---------------------|---------------------|
| 1. — | 7. 100,000 ohms. |
| 2. 30,000 ohms. | 8. .02 microfarad. |
| 3. 1,000 ohms. | 9. 500,000 ohms. |
| 4. 25 microfarads. | 10. .004 microfarad |
| 5. .001 microfarad. | 11. 500,000 ohms. |
| 6. 100,000 ohms. | |

Capacitor block: 4 red leads 0.25 microfarad.
1 yellow lead 0.5 microfarad.

N.B.—BEFORE LEAVING A STROMBERG-CARLSON RADIO RECEIVER IN A CUSTOMER'S HOME, SEE THAT EVERYBODY WHO IS LIKELY TO HANDLE THE RECEIVER FULLY UNDERSTANDS ITS OPERATION. BY SO DOING MANY UNNECESSARY SERVICE CALLS WILL BE AVOIDED.

Stromberg-Carlson

REPAIR
 SERVICE BULLETIN No. 632

Page 1

Model 632 Superheterodyne Radio Receiver

ALL-ELECTRIC, SCREEN GRID, FIVE VALVES AND RECTIFIER.

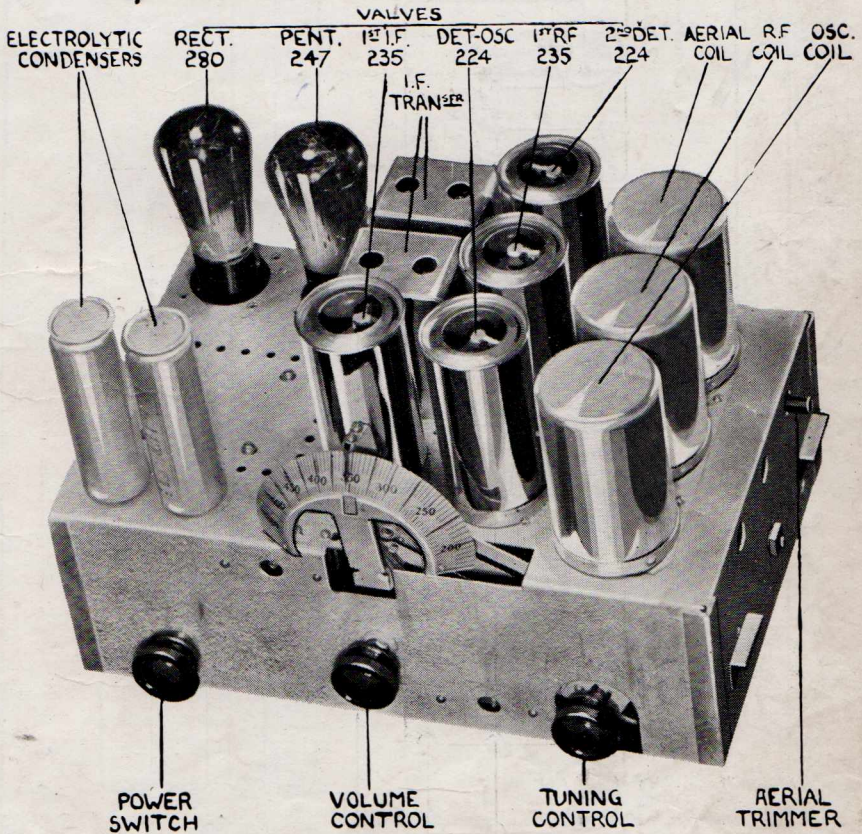

Chassis of 632 Model

This Service Bulletin is issued free of charge to all Authorised Stromberg-Carlson Distributors and Dealers. Applications for additional copies should be made direct to Stromberg-Carlson (Australasia) Ltd.

STROMBERG CARLSON AUSTRALASIA LIMITED
 STONEY AUSTRALIA

DRAWING No 35

CHANGES

DRAWN *J.P.B.*
 EXAMINED *J.P.N.*
 APPROVED
 DATE 25-3-32

*Radio Receiver Model 632-Superhet
 All Electric 5 Valves and Rectifier*

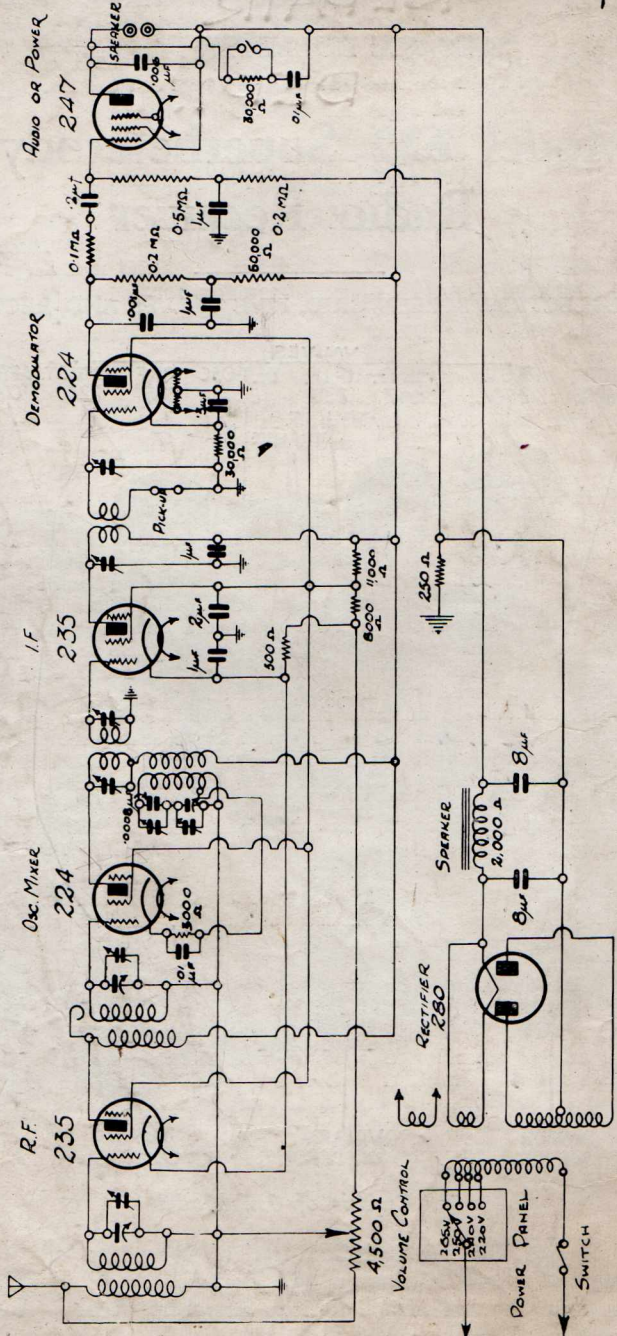

STROMBERG - CARLSON

SERVICE BULLETIN No. 632 (Continued)

Page :

Stromberg-Carlson Radio Receiver Model 632

ALL-ELECTRIC, SUPERHETERODYNE, FIVE VALVES
AND RECTIFIER.

This Receiver incorporates the well-known superheterodyne principle, which gives sufficient selectivity and sensitivity for the reception of local and inter-state stations, without over-lapping, at loud-speaker volume. The chassis is floated on rubber buffers inside the cabinet, to guard against any damage which may be caused by jolting in transit and to prevent any microphonic disturbances which otherwise might occur in service.

1. GENERAL INSTALLATION INSTRUCTIONS:—

(a) Aerial and Earth.

The usual procedure of a well-insulated outside aerial and short, well-connected earth should be followed. The aerial should not exceed 40 feet in length and, when an outside aerial cannot be provided, the looping of the wire around the picture rail will probably produce satisfactory results. To meet the special demands of a customer, the aerial may be looped around the inside of the radio cabinet, but this practice is not recommended as it limits the sensitivity of the receiver.

(b) Voltage Adjustment Panel.

Examine the Voltage Adjustment Panel, located at the rear of the chassis, by removing the cover-plate marked "Danger," previously making certain that the *power-plug is out of the socket*. It is not sufficient merely to switch off the current, the power-lead and socket *must be totally disconnected* from the mains. The voltage switch will be found to be marked or calibrated (on the chassis) in volts, thus, 220, 240, 250 and 265, and the switch arm must be set on one of these numbers which is nearest to, but not less than, the standard voltage of the mains to which the set is connected.

(c) Lay-Out of Components.

For the lay-out of components appearing on the top of the chassis, reference should be made to page 1 of this bulletin.

(d) Aerial Trimmer.

After installation, this Model should be finally adjusted to work at maximum efficiency with the aerial to be used. To do this, proceed as follows:—

Tune the receiver to some station around the low-wave length end of the scale—say, 200 to 250 metres—turn the volume control down until the incoming signal is just audible, then adjust by hand the small trimmer on the right-hand side of the chassis until a point of maximum signal is obtained. Once obtained this adjustment should not be altered. The tuning adjustments on the gang capacitor (the variable gang tuning condenser) and the trimmer capacitors on the Intermediate Frequency Transformers (tuned to 175 k.c.) are adjusted and sealed at the factory, at the time of calibration. These adjustments should on no account be touched or the seals broken unless a specially calibrated oscillator and indicating instrument are available, whereby such adjustments can be successfully carried out. In any repairs or adjustments, the above remarks in regard to the gang capacitor and intermediate transformers should be carefully noted.

STROMBERG - CARLSON

SERVICE BULLETIN No. 632 (Continued)

Page 4

2. VALVES.

All receivers leaving the factory are equipped with Valves inserted in the sockets. If for any reason it becomes necessary to remove the Valves, care should be taken to see that each one is replaced in the socket from which it was taken. The photograph of the chassis on page 1 shows the type and function of the valves and their exact location.

Rectifier	Type 280
Power Pentode	Type 247
Oscillator-Mixer	Type 224
Inter-Frequency	Type 235
Second Detector	Type 224
Radio Frequency	Type 235

3. SPEAKER.

The Speaker in this model is the Dynamic or moving coil type, and is matched to the pentode output valve. The field coil being used at the date of issue of this Bulletin has a resistance of 2000 ohms. Every receiver is tested for "hum-level" before leaving the factory. However, on some installations where special line fluctuations exist, any excessive hum thus noticed may sometimes be reduced by reversing the two inner leads on the loud speaker terminal strip. The Speaker connections terminate with a 4-pin plug at the receiver chassis. *This plug should not be removed while the current is turned on.*

4. OPERATION.

The more sensitive and selective the Receiver is the more care should be taken in its operation and tuning to obtain the best results. In Model 632 the left hand knob is the "on-off" power switch; the centre knob is the volume control, the right hand knob is the tuning control. Improper tuning will affect the quality of reproduction. Care should be taken to keep the volume control well down, then adjust the tuning control to the point of maximum undistorted signal, thereafter adjusting the volume to the desired level.

The 632 Receiver is a very sensitive instrument and, with the volume control adjusted to, or near to, its maximum position, a certain amount of background noise and hiss is inevitable. In general, the greater the sensitivity the greater the noise level. This condition, however, will only be noticed when the Receiver is adjusted for very distant and weak signals. Interstate reception will be normally obtained with ease and great volume and margin. Every care has been taken to design the receiver so that the ratio of noise level is kept as low as possible consistent with high sensitivity.

5. AUTOMATIC CLARIFIER.

This is an attachment fitted to the volume control to reduce the background noise when the Volume Control is approaching its maximum position of sensitivity. By this method the full tonal range of the receiver is available for all local and the more powerful interstate stations, while on very distant and weak signals, where the full sensitivity of the receiver is used, the noise level is automatically reduced.

6. PICK-UP JACKS.

Provision is made at the back of the chassis for the attachment of a phonograph pickup. Unless the receiver is issued from the factory as a phono-radio combination, the pickup jacks are shorted with a metal bar which must not be removed unless it is desired to insert a pick-up into the terminals. When the pickup is in use, care must be taken to see that the volume control on the receiver is turned right off, thereafter using the volume control supplied with the pickup.

7. VOLTAGES.

All voltages given in the undermentioned table are those which should be obtained when using a 0-60-120-300 volt voltmeter having a resistance of 1000 ohms. per volt. Voltages shown below 60 are to be read on 0-60 scale, those below 120 on the 0-120 scale, and those above 120 on the 0-300 scale. It is important to note that other voltmeters having

REVISED STROMBERG - CARLSON & AUDIOLA

SERVICE BULLETIN No. 633 and No. 693

VOLTAGES:

All voltages shown in the chart on Page 6 are those which should be obtained when using a 0-10-120-300-600 volt voltmeter having a resistance of 1,000 ohms. per volt. Voltages shown below 10 are to be read on 0-10 scale, those below 120 on the 0-120 scale, those below 300 on the 0-300 scale, and those above 300 on the 0-600 scale. It is important to note that other voltmeters having different internal resistances will give voltage readings different from those mentioned in the following table. Therefore, a 1,000 ohm. per volt voltmeter should be used.

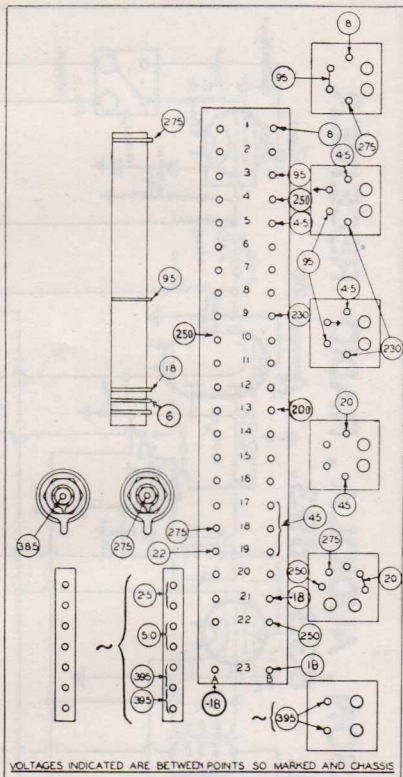

COMPONENTS:

The following list of components are listed to facilitate the servicing of the Receiver and as a guide to replacements.

The numbers refer to the position of the component on the assembly panel as illustrated.

- | | |
|--------------------------|-----------------------|
| 1. 8000 ohms. | 13. 0.5 microfarad |
| 2. 0.001 microfarad | 14. 0.0004 microfarad |
| 3. 0.1 microfarad | 15. 0.5 megohm |
| 4. 0.1 microfarad | 16. 0.02 microfarad |
| 5. 300 ohms. | 17. 0.0004 microfarad |
| 6. 0.5 microfarad | 18. 100,000 ohms. |
| 7. 0.02 microfarad | 19. 100,000 ohms. |
| 8. 0.1 microfarad | 20. 0.02 microfarad |
| 9. 100,000 ohms. | 21. 200 ohms. |
| 10. 0.1 microfarad | 22. 0.006 microfarad |
| 11. 1 megohm | 23. 25 microfarads |
| 12. 2 megohms | 24. 0.5 megohm. |
| 13b. to 18a. 8,000 ohms. | |

Voltage Divider values: 5300 ohms. (Field in Dual Speakers), 2500 ohms. 400 ohms. and 200 ohms.

Stromberg-Carlson

STROMBERG-CARLSON
SERVICE BULLETIN, No. 635.

Stromberg-Carlson Model 635 Superheterodyne

ALL-ELECTRIC, DUAL-WAVE

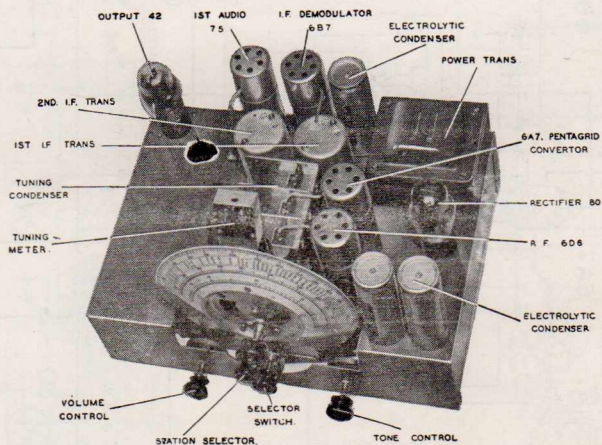

Chassis of 635 Model

This Service Bulletin is issued free of charge to all authorised Stromberg-Carlson Dealers. Applications for additional copies should be made direct to the nearest Distributor.

Stromberg-Carlson (Australasia) Ltd. reserves the right to make changes in design details at any time without incurring any obligations to install same on radio receivers previously sold.

N.B.—BEFORE LEAVING A STROMBERG-CARLSON RADIO RECEIVER IN A CUSTOMER'S HOME, SEE THAT EVERYBODY WHO IS LIKELY TO HANDLE THE RECEIVER FULLY UNDERSTANDS ITS OPERATION, BY SO DOING MANY UNNECESSARY SERVICE CALLS WILL BE AVOIDED.

Stromberg-Carlson Model 635 Superheterodyne

**ALL-ELECTRIC, DUAL-WAVE
FIVE VALVES AND RECTIFIER**

1. GENERAL DESCRIPTION OF RECEIVER:

This Model employs the latest superheterodyne principles, and has been designed to meet the demands of both high quality broadcast and short-wave reception.

The receiver is a 6-tube broadcast and short-wave receiver, having two wave bands. One band is the usual broadcast band from 200 to 500 metres, and the other is a short-wave band from 19-53 metres. This latter range has been covered by means of one set of coils, and includes the four important internationally assigned short-wave broadcast bands at 19, 25, 31, and 49 metres respectively. Thus, in addition to providing fine programmes from the usual broadcast stations, this receiver permits direct reception from principal short-wave broadcast transmitters in all parts of the world.

Short-wave facilities in this receiver are designed as integral parts of the apparatus. The tuning ranges are quickly interchangeable by means of a rotary switch. Ease and convenience of operation are assured by the dual ratio drive and the "Selectorlite" dial which indicates the range in operation by illuminating the corresponding portion of the dial. Both ranges are accurately calibrated, the short-wave band in metres, and the broadcast band both in metres and kilocycles. All important broadcast stations are also marked on the dial.

The short-wave range has the location of the 19, 25, 31, and 49 metre band indicated by heavy black lines.

2. INSTALLATION INSTRUCTIONS:

(a) Aerial.

The sensitivity of this model is such that for broadcasting reception a well-insulated wire about 20 or 30 feet in length, placed along the picture moulding in a room, or beneath the carpet, will prove satisfactory. Care should be taken to place all such indoor aerials as far away as possible from electric light or power conduits, and, in particular, clear of all unshielded flexible leads, since these latter are prolific radiators of undesirable electrical impulses.

An outdoor aerial is the most efficient, and is strongly recommended, especially for short-wave and long-distance daylight reception on the broadcast band. The length of this aerial should be from 30 to 50 feet. In noisy areas (due to electrical interference) the aerial should be erected as far as possible from and at right-angles to any electric power or light mains.

As a further precaution against undesirable pick-up, the lead-in should be a special "transposed" type, terminals being provided for its connection. Details of this type of aerial may be had on application to Stromberg-Carlson (Australasia), Limited.

Do not use shielded lead-in wire for short-wave reception.

SERVICE BULLETIN, No. 635 (Continued)**(b) Earth.**

The chassis should be connected to earth by means of an insulated wire attached to a water pipe by an approved clamp. It is preferable to connect the earth lead to the last section of the pipe where it enters the ground, thus avoiding the high resistance contacts at the joints. Should a water system not be available, an efficient earth may be obtained by driving a metal pipe or burying about four square feet of metal sheeting in moist earth; the connection to the metal should preferably be soldered.

(c) Voltage Adjustment Panel.

Before leaving the factory the voltage switch is set to the 240-volt setting. If the line voltage differs from this, the switch should be set to the position nearest to, but not less than the measured line voltage in the locality. The voltage tapings for 200, 220, 240, 265 volts are designated on the back of the chassis. The adjustment is readily carried out by means of a screwdriver on removing the danger plate.

When making any adjustment, see that the power plug is completely removed from the socket of the supply source.

(d) Trimmer Adjustments.

The trimmer capacitors on the coil assembly, and the trimmer capacitors on the Intermediate Frequency Transformers (tuned to 450 k.c.) are adjusted and sealed at the factory at the time of calibration. These adjustments should on no account be touched or seals broken unless a specially calibrated oscillator and indicating instrument are available, whereby such adjustments can be successfully carried out. In any repairs or adjustments the above remarks in regard to the coil assembly and intermediate transformer should be carefully noted.

3. OPERATION:**(a) Automatic Volume Control.**

This Model is so designed that the signal voltages fed to the audio system tend to adjust themselves to a constant level. This signal level is manually controlled and should be adjusted to the desired volume on a station of moderate or high power. The automatic feature will then tend to maintain this volume at a constant level on different signals of wide variations in intensity.

The effects of fading being thus reduced to an absolute minimum, constant attention to the volume control is obviated, especially on the reception of weak and distant stations.

(b) Visual Tuning Meter.

Since the Automatic Volume Control tends to keep the signal at a constant level, it would be difficult to tune to exact resonance by aural means (except on very weak signals). With a Visual Tuning Meter, however, tuning to exact resonance is always possible, and since improper tuning adversely affects the quality of reproduction, the correct tuning for any station is most important, and this condition is easily and quickly attained by means of the Visual Tuning Meter.

NOTE.—It may be observed that on one or two of the Australian Broadcasting Stations better quality is obtained by slightly detuning—to a point where the Tuning Meter Indicator is somewhat below the maximum swing. This effect is due to the method of carrier modulation employed by such Broadcasting Stations, and not to any defect in the Receiver nor to the method of tuning.

SERVICE BULLETIN, No. 635 (Continued)

6. PICK-UP JACKS:

Provision is made at the back of the Chassis for the attachment of a Phonograph Pick-up. To operate the pick-up, remove the metal bar between the centre and bottom jacks, and connect the leads from the pick-up to the centre and top jacks, as illustrated.

The metal bar must be replaced when the Receiver is again required for radio operation.

The Volume Control on the Receiver may be used to regulate the audio output from the pick-up.

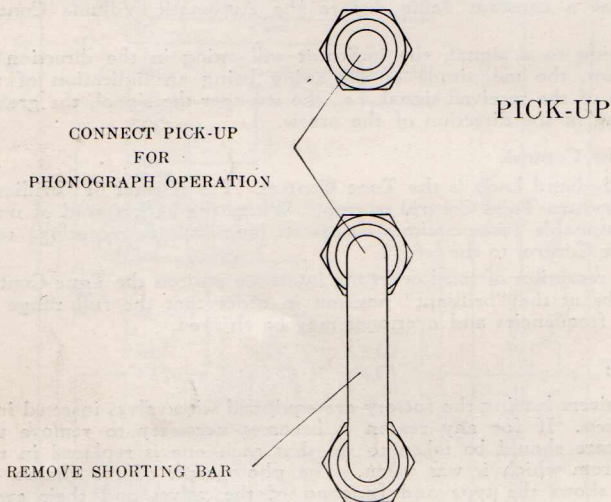

7. VOLTAGES:

Valve.	Plate.	Screen.	Cathode.
6D6	275	90	0
6A7	275	90	0
6B7	Osc. Plate 190	90	1.5
75	—	—	1.5
42	265	275	0

Bias for 6D6, 6A7, and 42 obtained from resistors in the negative H.T. lead. 6D6 and 6A7, 1.5 volts; 42, 18 volts. All voltages are measured from the above designated valve prongs to chassis with the line voltage at 240 volts.

The voltmeter used should have an internal resistance of 1000 ohms per volt.

8. COMPONENTS:

The numbers refer to the position of the component on the assembly panel.

- | | |
|-----------------------|---------------------|
| 1. 300 ohms. | 6. 4000 ohms. |
| 2. 0.0001 microfarad. | 7. 50,000 ohms. |
| 3. 1 megohm. | 8. 0.2 megohm. |
| 4. 0.1 megohm. | 9. 0.02 microfarad. |
| 5. 0.2 microfarad. | |

Capacitor Block: 4 red leads, 0.25 microfarad.
1 yellow lead, 0.5 microfarad.

S T R O M B E R G - C A R L S O N

STROMBERG - CARLSON SERVICE BULLETIN, No. 635.

ADDITIONS TO THE COMPONENT PANEL:

Commencing with serial No. 29304, the component panel for Model 635 will be as under:—

- | | |
|-----------------------|--------------------|
| 1. 300 ohms. | 6. 4000 ohms. |
| 2. 0.0001 microfarad. | 7. 50,000 ohms. |
| 3. 100,000 ohms. | 8. 200,000 ohms. |
| 4. 100,000 ohms. | 9. .04 microfarad. |
| 5. .02 microfarad. | 10. 30,000 ohms. |

.01 microfarad condenser connected between lugs No. 7 and 10.

An extra section of the wave change switch is attached to the coil unit. Its purpose is to short circuit the high note, and open circuit the low note compensation on the short-wave bands.

STROMBERG - CARLSON (AUSTRALASIA) LIMITED
 SYDNEY, AUSTRALIA

DRAWING No.

CHANGES

DRAWN *G.H.*

EXAMINED

APPROVED

MGN. DIRECTOR

DATE 10.6.35

MODIFIED CIRCUIT SHOWING TONE
 COMPENSATION. THIS ADDITION
 IS OPERATED FROM SERIAL No. 29304

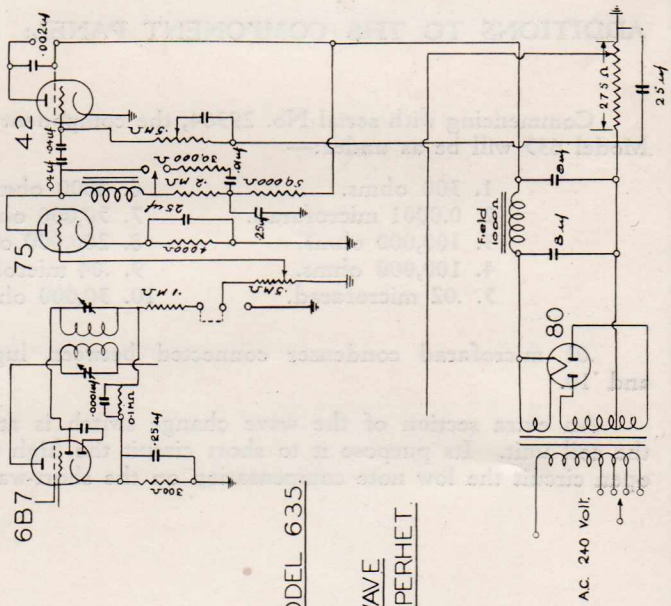

MODEL 635

DUAL WAVE
 SUPERHET

Stromberg-Carlson

Page 1

SERVICE BULLETIN No. 703

Radio Receiver Model 703

BATTERY-OPERATED, SUPERHETERODYNE, SEVEN VALVES

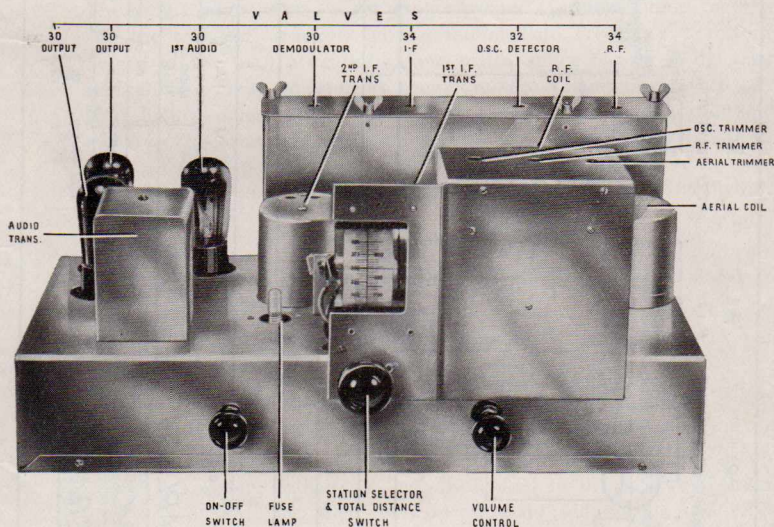

Chassis of Model 703

This Service Bulletin is issued free of charge to all authorised Stromberg-Carlson and Audiola Dealers. Applications for additional copies should be made direct to the nearest Distributor.

Stromberg-Carlson (Australasia) Ltd. reserves the right to make changes in design details at any time, without incurring any obligations to install same on Radio Receivers previously sold.

Radio Receiver Model 703

BATTERY-OPERATED, SUPERHETERODYNE, SEVEN VALVES

1.

The 703 Receiver has been developed from the popular 802-B battery-operated model, and incorporates a number of improved features.

The 703 model employs the autodyne principle, thereby eliminating the necessity for a separate oscillator.

A further decrease in the already low battery consumption of the 802-B has been accomplished in the 703 chassis, rendering this model exceptionally economical in operation without in any way sacrificing the quality of reproduction, or the power output.

The general installation instructions, and much of the data contained in the 802-B Service Bulletin, is applicable to the 703 Battery-operated Receiver.

The tuning adjustments on the gang capacitor (variable tuning condenser) and the trimmer capacitors on the Intermediate Frequency Transformers (tuned to 175 k.c.) are adjusted and sealed at the factory at the time of calibration. These adjustments should on no account be touched or the seals broken unless a specially calibrated oscillator and indicating instrument are to hand whereby such adjustments can be successfully carried out. In any repairs or adjustments the above remarks in regard to the gang capacitor and intermediate transformers should be carefully noted.

2. BATTERIES.

(i.) *A Battery*.—This consists of a 2 volt, 40-60 ampere-hour accumulator.

(ii.) *B and C Batteries*.—These comprise 4 heavy duty or Super 45 volt batteries.

To join the battery leads correctly to the batteries, reference should be made to the designation tabs on the leads, and to the colour code, as shown in the circuit diagram on page 2.

The four B batteries may be housed in the back of the cabinet on the lower shelf, two on the right and two on the left-hand side of the loud speaker. The A battery may then be placed in between the B batteries or on the floor immediately behind the cabinet.

3. OPERATION.

The more sensitive and selective the receiver is, the greater the care to be taken in the operation and tuning to obtain the best results. In this model the left-hand knob is the "on-off" switch, the right-hand knob is the volume control, and the centre knob is the tuning control. The centre

STROMBERG - CARLSON

Page 4

SERVICE BULLETIN No. 703 (Continued)

knob or Tuning Control also functions as a Local-Distance Switch. For full sensitivity, push switch in. For the reception of strong local signals, pull switch out. Improper tuning will affect the quality of reproduction. Care should be taken to keep the volume control well down, then adjust the tuning control to the point of maximum undistorted signal, thereafter adjusting the volume to the desired level. Judicious use of the volume and tuning controls in the Model 703 will assist in the economy of battery consumption.

4. COMPONENTS.

The following list of components is given to facilitate the servicing of the Receiver and as a guide to replacements.

The numbers refer to the position of the component on the assembly panel.

- | | |
|--------------------|---------------------|
| 1. blank | 10. blank |
| 2. .02 microfarads | 11. .001 microfarad |
| 3. 30,000 ohms | 12. 100,000 ohms |
| 4. .1 microfarad | 13. .02 microfarad |
| 5. 25 microfarads | 14. 100,000 ohms |
| 6. 2,000 ohms | 15. 500,000 ohms |
| 7. 1,600 ohms | 16. blank |
| 8. 250 ohms | 17. .01 microfarad |
| 9. 1,000 ohms | |

Condenser Block: 4 Red Leads, .25 microfarads
1 Yellow Lead, .5 microfarads

5. VOLTAGES.

Valve	Function	Screen Volts	Plate Volts
232	Radio Frequency	67.5	157.5
232	Det.-Oscillator	45	157.5
234	I.F.	67.5	157.5
230	2nd Detector	—	80
230	Driver	—	30
230 }	Push-Pull	—	148.5
230 }	Class B	—	148.5

All voltages are measured from the above designated valve prongs to chassis base, with volume control at full "on" position.

The voltmeter used should have a resistance of 1000 ohms per volt.

N.B.—BEFORE LEAVING THE STROMBERG-CARLSON RADIO RECEIVER IN A CUSTOMER'S HOME, SEE THAT EVERYBODY WHO IS LIKELY TO HANDLE THE RECEIVER FULLY UNDERSTANDS ITS OPERATION. BY SO DOING MANY UNNECESSARY SERVICE CALLS MAY BE AVOIDED.

Stromberg-Carlson

Page 1

SERVICE BULLETIN No. 703

Radio Receiver Model 703

BATTERY-OPERATED, SUPERHETERODYNE, SEVEN VALVES

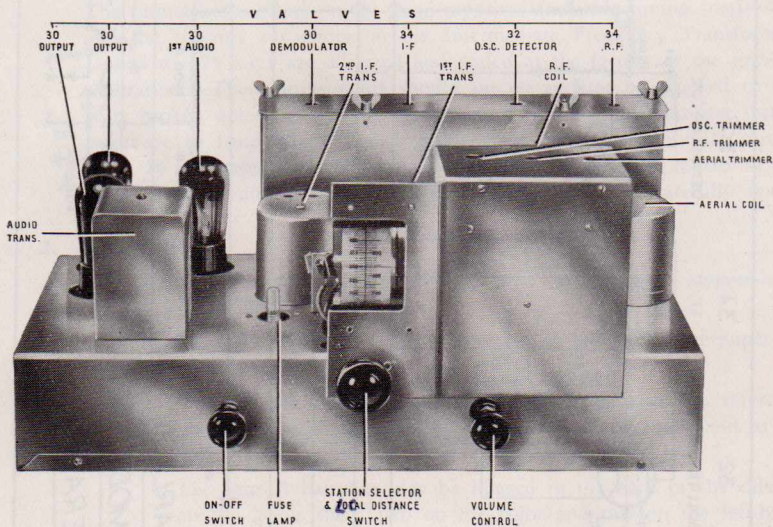

Chassis of Model 703

This Service Bulletin is issued free of charge to all authorised Stromberg-Carlson and Audiola Dealers. Applications for additional copies should be made direct to the nearest Distributor.

Stromberg-Carlson (Australasia) Ltd. reserves the right to make changes in design details at any time, without incurring any obligations to install same on Radio Receivers previously sold.

STROMBERG-CARLSON (AUSTRALASIA) LIMITED
 SYDNEY AUSTRALIA

Drawing No Z134

CHANGES

DRAWN T.W.S
 EXAMINED F.J.Y.
 APPROVED DIRECTOR
 DATE 14-7-33

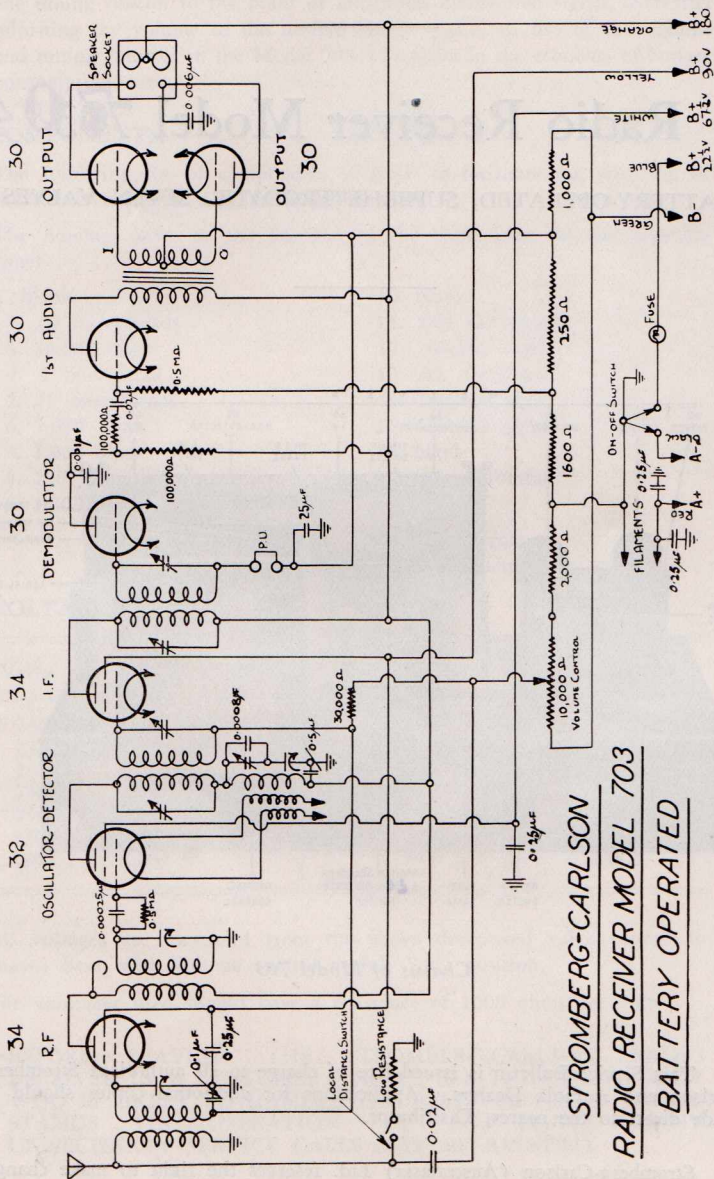

STROMBERG-CARLSON
RADIO RECEIVER MODEL 703
BATTERY OPERATED

Radio Receiver Model 703

BATTERY-OPERATED, SUPERHETERODYNE, SEVEN VALVES

1.

The 703 Receiver has been developed from the popular 802-B battery-operated model, and incorporates a number of improved features.

The 703 model employs the autodyne principle, thereby eliminating the necessity for a separate oscillator.

A further decrease in the already low battery consumption of the 802-B has been accomplished in the 703 chassis, rendering this model exceptionally economical in operation without in any way sacrificing the quality of reproduction, or the power output.

The general installation instructions, and much of the data contained in the 802-B Service Bulletin, is applicable to the 703 Battery-operated Receiver.

The tuning adjustments on the gang capacitor (variable tuning condenser) and the trimmer capacitors on the Intermediate Frequency Transformers (tuned to 175 k.c.) are adjusted and sealed at the factory at the time of calibration. These adjustments should on no account be touched or the seals broken unless a specially calibrated oscillator and indicating instrument are to hand whereby such adjustments can be successfully carried out. In any repairs or adjustments the above remarks in regard to the gang capacitor and intermediate transformers should be carefully noted.

2. **BATTERIES.**

(i.) *A Battery.*—This consists of a 2 volt, 40-60 ampere-hour accumulator.

(ii.) *B and C Batteries.*—These comprise 4 heavy duty or Super 45 volt batteries.

To join the battery leads correctly to the batteries, reference should be made to the designation tabs on the leads, and to the colour code, as shown in the circuit diagram on page 2.

The four B batteries may be housed in the back of the cabinet on the lower shelf, two on the right and two on the left-hand side of the loud speaker. The A battery may then be placed in between the B batteries or on the floor immediately behind the cabinet.

3. **OPERATION.**

The more sensitive and selective the receiver is, the greater the care to be taken in the operation and tuning to obtain the best results. In this model the left-hand knob is the "on-off" switch, the right-hand knob is the volume control, and the centre knob is the tuning control. The centre

STROMBERG - CARLSON

Page 4

SERVICE BULLETIN No. 703 (Continued)

knob or Tuning Control also functions as a Local-Distance Switch. For full sensitivity, push switch in. For the reception of strong local signals, pull switch out. Improper tuning will affect the quality of reproduction. Care should be taken to keep the volume control well down, then adjust the tuning control to the point of maximum undistorted signal, thereafter adjusting the volume to the desired level. Judicious use of the volume and tuning controls in the Model 703 will assist in the economy of battery consumption.

4. COMPONENTS.

The following list of components is given to facilitate the servicing of the Receiver and as a guide to replacements.

The numbers refer to the position of the component on the assembly panel.

- | | |
|--------------------|---------------------|
| 1. blank | 10. blank |
| 2. .02 microfarads | 11. .001 microfarad |
| 3. 30,000 ohms | 12. 100,000 ohms |
| 4. .1 microfarad | 13. .02 microfarad |
| 5. 25 microfarads | 14. 100,000 ohms |
| 6. 2,000 ohms | 15. 500,000 ohms |
| 7. 1,600 ohms | 16. blank |
| 8. 250 ohms | 17. .01 microfarad |
| 9. 1,000 ohms | |

Condenser Block: 4 Red Leads, .25 microfarads
1 Yellow Lead, .5 microfarads

5. VOLTAGES.

Valve	Function	Screen Volts	Plate Volts
232	Radio Frequency	67.5	157.5
232	Det.-Oscillator	45	157.5
234	I.F.	67.5	157.5
230	2nd Detector	—	80
230	Driver	—	30
230 }	Push-Pull	—	148.5
230 }	Class B	—	148.5

All voltages are measured from the above designated valve prongs to chassis base, with volume control at full "on" position.

The voltmeter used should have a resistance of 1000 ohms per volt.

N.B.—BEFORE LEAVING THE STROMBERG-CARLSON RADIO RECEIVER IN A CUSTOMER'S HOME, SEE THAT EVERYBODY WHO IS LIKELY TO HANDLE THE RECEIVER FULLY UNDERSTANDS ITS OPERATION. BY SO DOING MANY UNNECESSARY SERVICE CALLS MAY BE AVOIDED.

Stromberg-Carlson

STROMBERG-CARLSON
SERVICE BULLETIN No. 734

Stromberg-Carlson Model 734 Superheterodyne

ALL-ELECTRIC, ALL-WAVE

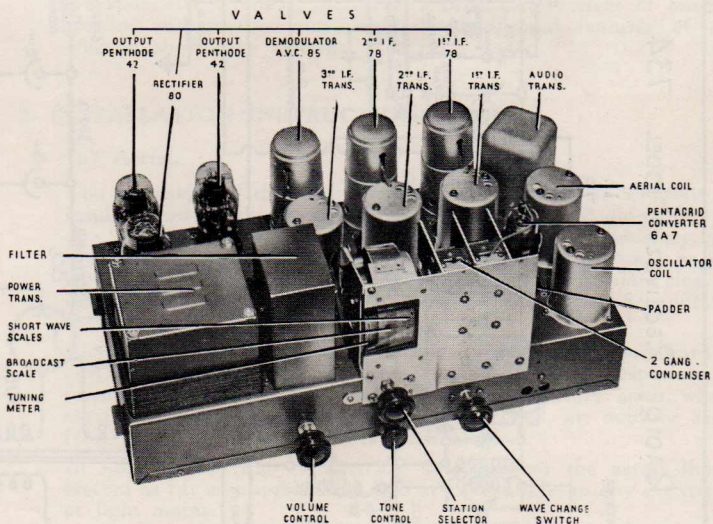

Chassis of 734 Model

This Service Bulletin is issued free of charge to all authorised Stromberg-Carlson Dealers. Applications for additional copies should be made direct to the nearest Distributor.

Stromberg-Carlson (Australasia) Ltd. reserves the right to make changes in design details at any time without incurring any obligations to instal same on radio receivers previously sold.

STROMBERG-CARLSON (AUSTRALASIA) LIMITED
 SYDNEY AUSTRALIA.

DRAWING No Z163

CHANGES

DRAWN J.W.S.
 EXAMINED *[Signature]*
 APPROVED
 MAN DIRECTOR
 DATE 24-1-34

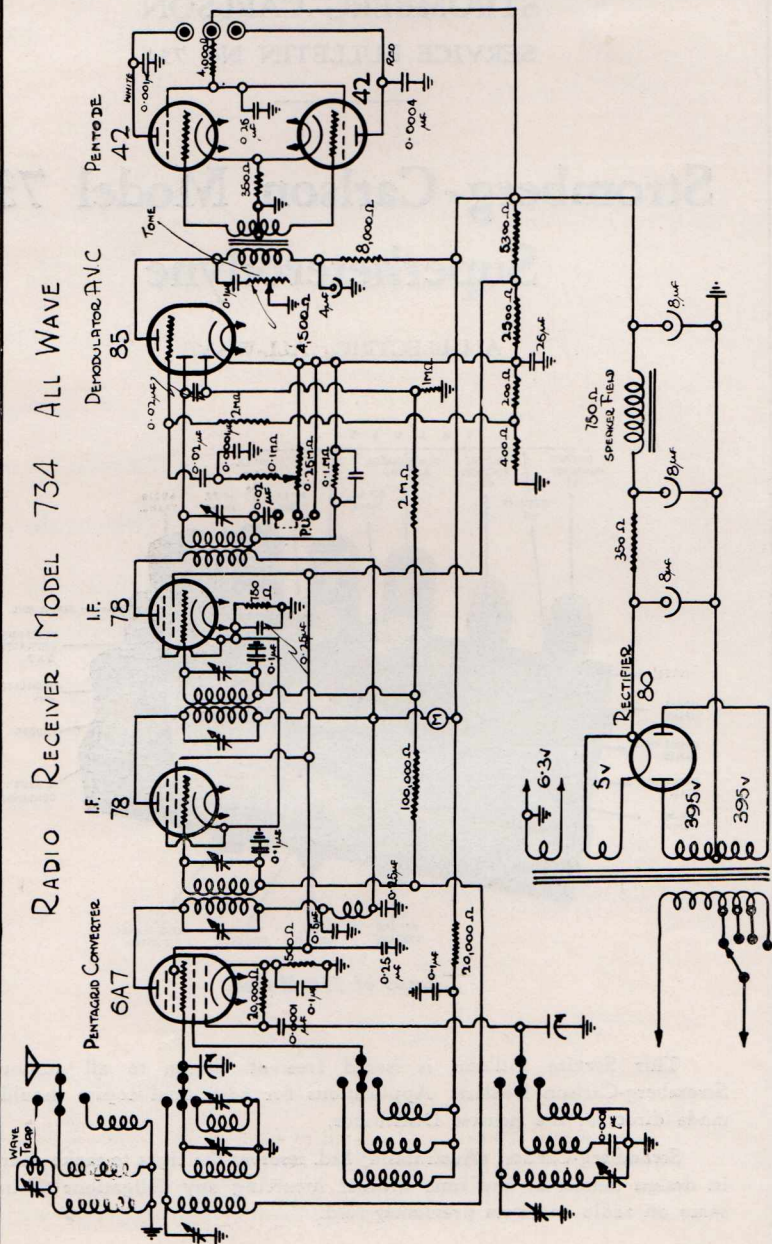

Stromberg-Carlson Model 734

Superheterodyne

**ALL-ELECTRIC, ALL-WAVE
SIX VALVES AND RECTIFIER**

1. GENERAL DESCRIPTION OF RECEIVER:

This Model employs the latest superheterodyne principles, and has been primarily designed as a high-quality Broadcast Receiver. In accordance with the Stromberg-Carlson policy of making available to the public the achievements of the foremost radio laboratories, the Model 734 incorporates the short-wave spectrums.

It must, of course, be conceded that the best reception—free from interference and fading—is that obtained from the local or strong interstate stations. Nevertheless, there is a distinct fascination in the “picking-up” of far-distant or overseas stations.

The Model 734 offers, therefore, a broadcast receiver of outstanding quality and performance, with the additional features of a most efficient short-wave receiver.

2. INSTALLATION INSTRUCTIONS:

(a) Aerial.

The sensitivity of this model is such that in most installations a well-insulated wire about 20 to 30 feet in length, placed along the picture moulding in a room, or beneath the carpet, will prove satisfactory. Care should be taken to place all such indoor aerials as far away as possible from electric light or power conduits, and in particular, clear of all unshielded flexible leads, since these latter are prolific radiators of undesirable electrical impulses.

An outdoor aerial is the most efficient, especially for short-wave reception, therefore this type of aerial is to be preferred—especially where facilities for such are readily obtainable. In country areas, where the maximum receptivity of the receiver is desired, an outdoor aerial of from 30 to 50 feet in length is recommended.

In noisy areas (due to electrical interference) the aerial should be erected as far as possible from and at right angles to any electric power or light mains.

As a further precaution against undesirable pick-up, the lead-in should be a special “transposed” type, details of which may be had on application to Stromberg-Carlson (Australasia) Ltd.

Do not use shielded lead-in wire for short-wave reception.

(b) Earth.

The chassis should be connected to earth by means of an insulated wire attached to a water pipe by an approved clamp. It is preferable to connect the earth lead to the last section of the pipe where it enters the ground, thus avoiding the high resistance contacts at the joints. Should a water system not be available, an efficient earth may be obtained by driving a metal pipe or burying about four square feet of

SERVICE BULLETIN No. 734 (Continued)

Page 4

metal sheeting in moist earth; the connection to the metal should preferably be soldered.

(c) Voltage Adjustment Panel.

Before leaving the factory the power lead is connected to the 240-volt tapping on the power transformer. If the line voltage differs from this the power lead should be unsoldered from the 240-volt tapping and soldered to the tapping which is marked with the voltage nearest to, but not less than, the measured line voltage in the locality. The voltage tappings for 200, 220, 240, 260 volts are designated on the power transformer.

When making any adjustment, see that the power plug is completely removed from the socket of the supply source.

(d) Trimmer Adjustments.

The tuning adjustments on the gang capacitor (the variable gang tuning condenser) and the trimmer capacitors on the Intermediate Frequency Transformers (tuned to 465 k.c.) are adjusted and sealed at the factory at the time of calibration. These adjustments should on no account be touched or the seals broken unless a specially calibrated oscillator and indicating instrument are available whereby such adjustments can be successfully carried out. In any repairs or adjustments the above remarks in regard to the gang capacitor and intermediate transformers should be carefully noted.

3. OPERATION:**(a) Automatic Volume Control.**

This Model is so designed that the signal voltages fed to the audio system, tend to adjust themselves to a constant level. This signal level is manually controlled and should be adjusted to the desired volume on a station of moderate or high power. The automatic feature will then tend to maintain this volume at a constant level on different signals of wide variations in intensity.

The effects of fading being thus reduced to an absolute minimum, constant attention to the volume control is obviated, especially on the reception of weak and distant stations.

(b) Visual Tuning Meter.

Since the Automatic Volume Control tends to keep the signal at a constant level, it would be difficult to tune to exact resonance by aural means (except on very weak signals). With a Visual Tuning Meter, however, tuning to exact resonance is always possible, and since improper tuning adversely affects the quality of reproduction, the correct tuning for any station is most important, and this condition is easily and quickly attained by means of the Visual Tuning Meter.

NOTE.—It may be observed that on one or two of the Australian Broadcasting Stations better quality is obtained by slightly detuning—to a point where the Tuning Meter Indicator is somewhat below the maximum swing. This effect is due to the method of carrier modulation employed by such Broadcasting Stations, and not to any defect in the Receiver nor to the method of tuning.

SERVICE BULLETIN No. 734 (Continued)

Should complete silence be desired when tuning over the dial the Manual Volume Control may be turned to the "off" position and the tuning performed visually by observing the swing of the Tuning Meter Indicator, then turning up the manual control when the desired setting is obtained.

When the Receiver is first turned on, the indicator on the Tuning Meter will move down to a fixed position.

On tuning to a signal the indicator will rise, the height of the swing being an indication of the strength of the received signal; i.e., the stronger the signal the greater the vertical swing.

It is interesting to note the wide variations of intensity from incoming signals as observed by the swing of the indicator on the Tuning Meter, at the same time noting that the volume of the Receiver is being maintained at a constant value due to the Automatic Volume Control Device.

(c) Wave-band or Selector Control.

The Wave-band Control (right-hand knob) is a three-position switch. In its normal position, with the white indicating spot in the vertical centre, the Receiver operates on the Broadcast band, from 200 to 550 metres. With the switch tuned to the left or anti-clockwise position (red spot vertical) the Receiver operates on the short-wave band, from 16 to 40 metres. With the switch turned to the right or clockwise position (green spot vertical) the Receiver operates on the short-wave band, from 40 to 95 metres. See Fig. 1.

The dial is calibrated in three bands to correspond with the foregoing switch positions.

(d) Tone Control.

The lower centre knob is the Tone Control. For normal or "brilliant" reception turn Tone Control to right. Where the background of noise is objectionable (as sometimes occurs on long-distance reception) turn the Tone Control to the left.

For the reception of local or strong interstate stations the Tone Control should be at the "brilliant" position in order that the full range of musical frequencies and overtones may be enjoyed.

4. VALVES:

All Receivers leaving the factory are equipped with valves inserted into the sockets. If for any reason it becomes necessary to remove the valves, care should be taken to see that each one is replaced in the socket from which it was taken. The photograph of the chassis on page 1 shows the type and function of the valves and their exact location.

Function of Valve.	Type of Valve.
Pentagrid Converter	6A7
First I.F.	78
Second I.F.	78
A.V.C.-Detector	85
Power Pentodes Push-Pull	42
Rectifier	80

SERVICE BULLETIN No. 734 (Continued)

Page 6

5. SPEAKER:

The speaker in this Model is the Dynamic or moving coil type, and is matched to the output valves. The field coil being used at the date of issue of this Bulletin has a resistance of 750 ohms. The speaker terminates in a five-pin plug at the Receiver chassis.

THIS PLUG SHOULD NOT BE REMOVED WHILE THE CURRENT IS TURNED ON.

6. PICK-UP JACKS:

Provision is made at the back of the Chassis for the attachment of a Phonograph Pick-up. To operate the pick-up, remove the metal bar between the centre and right-hand jacks and connect the leads from the pick-up to the centre and left-hand jacks, as illustrated.

The metal bar must be replaced when the Receiver is again required for radio operation.

The Volume Control on the Receiver may be used to regulate the audio output from the pick-up.

Some makes of Magnetic Pick-ups deliver comparatively low voltages, and in such cases, where these are used, an audio transformer of approximately 1:3 ratio should be used between the pick-up and Receiver.

PICK - UP

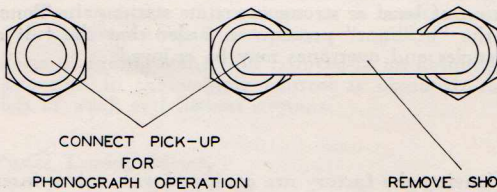

SERVICE BULLETIN No. 734 (Continued)

7. VOLTAGES:

Valve.	Plate.	Screen.	Cathode
6A7 Pentagrid	{ 250 Anode 185	90	4
77 I.F.		90	3
77 I.F.	250	90	3
85 Duo-Diode Triode	190	—	Bias 10
42 + 42 Push-Pull	250	230	17

All voltages are measured from the above designated valve prongs to chassis (except Bias on the 85) with Volume Control at the "full-on" position.

The voltmeter used should have an internal resistance of 1,000 ohms per volt.

8. COMPONENTS:

The following list of components is given to facilitate the servicing of the Receiver and as a guide to replacements.

The numbers refer to the position of the component on the assembly panel.

- | | |
|---------------------|------------------------|
| 1. 0.1 microfarad. | 10. 0.0001 microfarad. |
| 2. 100,000 ohms. | 11. 100,000 ohms. |
| 3. — | 12. 0.02 microfarad. |
| 4. 750 ohms. | 13. 2 megohm. |
| 5. 0.1 microfarad. | 14. 0.1 microfarad. |
| 6. 2 megohm. | 15. 8,000 ohms. |
| 7. 1 megohm. | 16. 350 ohms. |
| 8. 0.02 microfarad. | 17. 4,000 ohms. |
| 9. 25 microfarad. | |

- Small Panel: 18. 500 ohms.
 19. 0.1 microfarad.
 20. 0.1 microfarad.
 21. 20,000 ohms.

Large Voltage Divider: 5,300, 2,500, 200, 400 ohms.

Small " " 350 ohms.

Capacitor Block: 4 red leads, 0.25 microfarad.
 1 yellow lead, 0.5 microfarad.

N.B.—BEFORE LEAVING A STROMBERG-CARLSON RADIO RECEIVER IN A CUSTOMER'S HOME, SEE THAT EVERYBODY WHO IS LIKELY TO HANDLE THE RECEIVER FULLY UNDERSTANDS ITS OPERATION. BY SO DOING MANY UNNECESSARY SERVICE CALLS WILL BE AVOIDED.

Stromberg-Carlson

STROMBERG-CARLSON
SERVICE BULLETIN, No. 736.

Stromberg - Carlson Model 736 Superheterodyne

ALL-ELECTRIC, DUAL-WAVE
SIX VALVES AND RECTIFIER

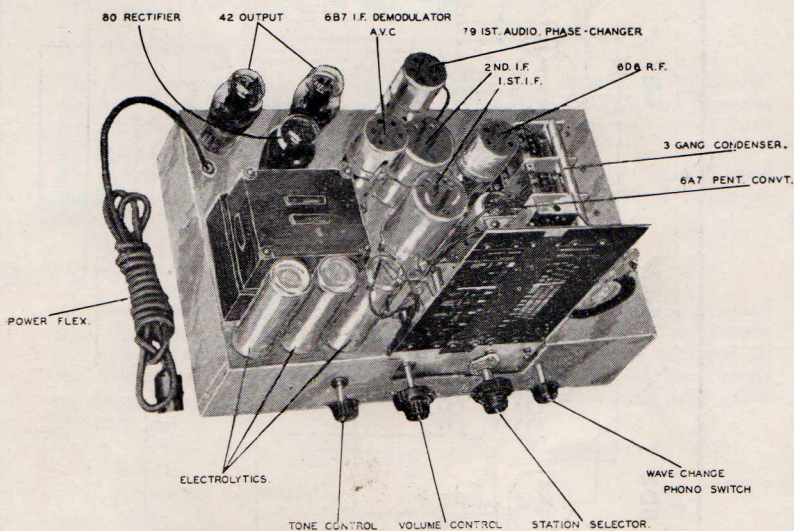

Chassis of 736 Model.

This Service Bulletin is issued free of charge to all authorised Stromberg-Carlson Dealers. Applications for additional copies should be made direct to the nearest Distributor.

Stromberg-Carlson (Australasia) Ltd. reserves the right to make changes in design details at any time without incurring any obligations to install same on radio receivers previously sold.

Stromberg-Carlson Model 736

Superheterodyne

**ALL-ELECTRIC, DUAL-WAVE
SIX VALVES AND RECTIFIER**

1 GENERAL DESCRIPTION OF RECEIVER:

This Model employs the latest superheterodyne principles, and has been designed to meet the demands of both high quality broadcast and short-wave reception.

The receiver is a 7-tube broadcast and short-wave receiver, having two wave bands. One band is the usual broadcast extending from 195 to 570 metres, and the other a short-wave band from 16.8 to 51 metres. The extension of the broadcast range has been made so that stations located on the extreme ends of the band can be correctly tuned.

The short-wave range has been covered by means of one set of coils, and includes the five important internationally assigned short-wave broadcasting bands at 16.8, 19, 25, 31, and 49 metres respectively. Thus, in addition to providing fine programmes from the usual broadcast stations, this receiver permits direct reception from principal short-wave broadcast transmitters in all parts of the world.

Short-wave facilities in this receiver are designed as integral parts of the apparatus. The tuning ranges are quickly interchangeable by means of a rotary switch, which also controls the gramophone pick-up operation. Ease and convenience of operation are assured by the dual ratio drive and the open-faced Selectorlite dial. Both ranges are accurately calibrated—the short-wave band in metres, and the broadcast band in kilocycles. All important broadcast stations are also marked on the dial.

The short-wave range has the location of the 16.8, 19, 25, 31, and 49 metre bands indicated by heavy white lines.

Excellent reproduction of the full audio frequency range up to 6000 cycles is obtained from the specially designed resistance coupled (paraphase) push-pull audio system, which includes tone compensation to replace any loss of high audio frequencies caused by highly selective radio frequency circuits.

2. INSTALLATION INSTRUCTIONS:

(a) Aerial.

The sensitivity of this model is such that for broadcasting reception a well-insulated wire about 20 or 30 feet in length, placed along the picture moulding in a room, or beneath the carpet, will prove satisfactory. Care should be taken to place all such indoor aerials as far away as possible from electric light or power conduits, and, in particular, clear of all unshielded flexible leads, since these latter are prolific radiators of undesirable electrical impulses.

An outdoor aerial is the most efficient, and is strongly recommended, especially for short-wave and long-distance daylight reception on the

SERVICE BULLETIN, No. 736 (Continued)

Page 4

broadcast band. The length of this aerial should be from 30 to 50 feet. In noisy areas (due to electrical interference) the aerial should be erected as far as possible from and at right-angles to any electric power or light mains.

As a further precaution against undesirable pick-up, the lead-in should be a special "transposed" type, terminals being provided for its connection. Details of this type of aerial may be had on application to Stromberg-Carlson (Australasia), Limited.

Do not use shielded lead-in wire for short-wave reception.

(b) Earth.

Where required by the wiring rules of the S.A.A., the chassis should be connected to earth by means of an insulated wire attached to a water pipe by an approved clamp. It is preferable to connect the earth lead to the last section of the pipe where it enters the ground, thus avoiding the high resistance contacts at the joints. Should a water system not be available, an efficient earth may be obtained by driving a metal pipe or burying about four square feet of metal sheeting in moist earth; the connection to the metal should preferably be soldered. If a transposed or any other type of balanced aerial system is not being used, and the rules call for the chassis not being earthed, then a radio earth may be connected to the terminal marked E_1 .

(c) Voltage Adjustment Panel.

Before leaving the factory the voltage switch is set to the 240-volt setting. If the line voltage differs from this, the switch should be set to the position nearest to, but not less than the measured line voltage in the locality. The voltage tappings for 200-230, 230-265 volts are designated on the back of the chassis. The adjustment is readily carried out by means of a screwdriver on removing the danger plate.

When making any adjustment, SEE THAT THE POWER PLUG IS COMPLETELY REMOVED FROM THE SOCKET OF THE SUPPLY SOURCE.

(d) Trimmer Adjustments.

The trimmer capacitors on the coil assembly, and the trimmer capacitors on the Intermediate Frequency Transformers (tuned to 392 k.c.) are adjusted and sealed at the factory at the time of calibration. These adjustments should on no account be touched or seals broken unless a specially calibrated oscillator and indicating instrument are available, whereby such adjustments can be successfully carried out. In any repairs or adjustments the above remarks in regard to the coil assembly and intermediate transformer should be carefully noted.

3. OPERATION:**(b) Automatic Volume Control.**

This Model is so designed that the signal voltages fed to the audio system tend to adjust themselves to a constant level. This signal level is manually controlled and should be adjusted to the desired volume on a station of moderate or high power. The automatic feature will then tend to maintain this volume at a constant level on different signals of wide variations in intensity.

The effects of fading being thus reduced to an absolute minimum, constant attention to the volume control is obviated, especially on the reception of weak and distant stations.

(b) Visual Tuning Meter.

Since the Automatic Volume Control tends to keep the signal at a constant level, it would be difficult to tune to exact resonance by aural means (except on very weak signals). With a Visual Tuning Meter, however, tuning to exact resonance is always possible, and since improper tuning adversely affects the quality of reproduction, the correct tuning for any station is most important, and this condition is easily and quickly attained by means of the Visual Tuning Meter.

Should complete silence be desired when tuning over the dial the Manual Volume Control may be turned to the "off" position and the tuning performed visually by observing the swing of the Tuning Meter Indicator, then turning up the manual control when the desired setting is obtained.

When the Receiver is first turned on, the indicator on the Tuning Meter will move across to a fixed position.

It is interesting to note the wide variations of intensity from incoming signals as observed by the swing of the indicator on the Tuning Meter, at the same time noting that the volume of the Receiver is being maintained at a constant value due to the Automatic Volume Control Device.

On tuning to a signal, the indicator will swing in the direction of the arrow, the magnitude of the swing being an indication of the strength of the received signal, i.e., the stronger the signal, the greater the swing in the direction of the arrow.

(c) Tone Control.

The left-hand knob is the Tone Control. For normal or "brilliant" reception turn Tone Control to right. Where the background of noise is objectionable (as sometimes occurs on long-distance reception) turn the Tone Control to the left.

For the reception of local or strong interstate stations the Tone Control should be at the "brilliant" position in order that the full range of musical frequencies and overtones may be enjoyed.

4. VALVES:

All Receivers leaving the factory are equipped with valves inserted into the sockets. If for any reason it becomes necessary to remove the valves, care should be taken to see that each one is replaced in the socket from which it was taken. The photograph of the chassis on page 1 shows the type and function of the valves and their exact location.

Function of Valve.	Type of Valve.
R.F.	6D6
Pentagrid Converter	6A7
I.F.A.V.C. Det.	6B7
1st A.F. Phase Changer	79
Output	42 + 42
Rectifier	80

5. SPEAKER:

The speaker in this Model is the Dynamic or moving coil type, and is matched to the output valve. The field coil being used at the date of issue of this Bulletin has a resistance of 1000 ohms. The speaker terminates in a seven-pin plug at the Receiver chassis.

THIS PLUG SHOULD NOT BE REMOVED WHILE THE CURRENT IS TURNED ON.

SERVICE BULLETIN, No. 736 (Continued)

Page 6

6. PICK-UP JACKS:

Provision is made on the back of the chassis for the attachment of a Phonograph Pick-up. The pick-up is brought into operation by turning the wave change switch fully to the left. The operation of the switch also removes any possibility of any radio programmes being heard while the pick-up is in use. The pick-up may be left permanently connected when the switch is changed back for radio operation.

The volume control on the Receiver may be used to regulate the audio output from the pick-up.

7. VOLTAGES:

Valve.	Plate.	Screen.	Cathode.
6D6	250	—	2
6A7	250	—	2
6B7	Osc. Plate 180	—	8
79	250	—	—
42's	100	—	—
	240	250	17

The screens of the 6D6, 6A7, and 6B7 are series fed through 50,000 ohms from 250 volts.

All voltages are measured from the above designated valve prongs to chassis, with the line voltage at 240 volts.

The voltmeter used should have an internal resistance of 1000 ohms per volt.

8. COMPONENTS:

The numbers refer to the position of the component on the assembly panel.

Panel No. 1.—On Back of Chassis.

- | | | |
|------------------|-------------------|-------------------|
| 1. 100,000 ohms. | 7. 200,000 ohms. | 13. 200,000 ohms. |
| 2. .0001 mf. | 8. .001 mf. | 14. 20,000 ohms. |
| 3. 100,000 ohms. | 9. 50,000 ohms. | 15. .5 mf. |
| 4. .1 mf. | 10. .1 mf. | 16. .1 mf. |
| 5. 2000 ohms. | 11. 500,000 ohms. | 17. 500,000 ohms. |
| 6. 25 mf. | 12. 20,000 ohms. | |

Panel No. 2.—Across Chassis.

- | | |
|-----------------|---------------|
| 1. 50,000 ohms. | 6. .1 mf. |
| 2. .1 mf. | 7. 1000 ohms. |
| 3. 100 ohms. | 8. .1 mf. |
| 4. .1 mf. | 9. .1 mf. |
| 5. 300 ohms. | 10. .1 mf. |

N.B.—BEFORE LEAVING A STROMBERG-CARLSON RADIO RECEIVER IN A CUSTOMER'S HOME, SEE THAT EVERYBODY WHO IS LIKELY TO HANDLE THE RECEIVER FULLY UNDERSTANDS ITS OPERATION. BY SO DOING MANY UNNECESSARY SERVICE CALLS WILL BE AVOIDED.

Stromberg-Carlson

SERVICE BULLETIN No. 802

Page 1

Radio Receiver Models 802A and 802B

BATTERY-OPERATED, SUPERHETERODYNE, EIGHT VALVES

NOTE.—The Model 802A uses type 232 Valves in the Intermediate Frequency and Radio Frequency stages. Models marked 802B use type 234 Valves instead.

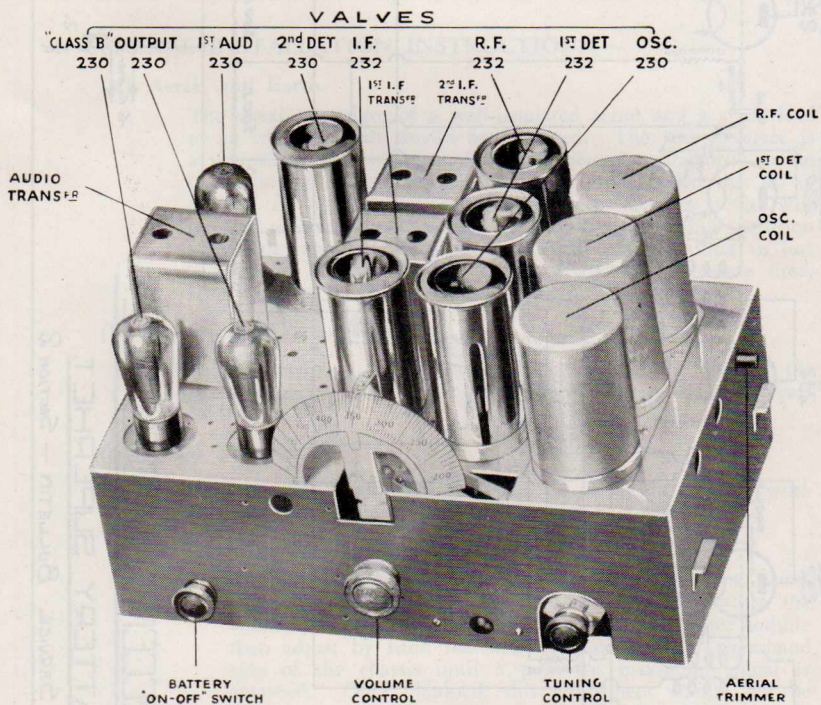

This Service Bulletin is issued free of charge to all Authorised Stromberg-Carlson Distributors and Dealers. Applications for additional copies should be made direct to Stromberg-Carlson (Australasia) Ltd.

STROMBERG CARLSON (AUSTRALASIA) LIMITED SYDNEY AUSTRALIA		DRAWING NO
CHANGES		DRAWN IWS
		EXAMINED S.P.T.H.
		APPROVED
		DIRECTOR
		DATE 21-7-32

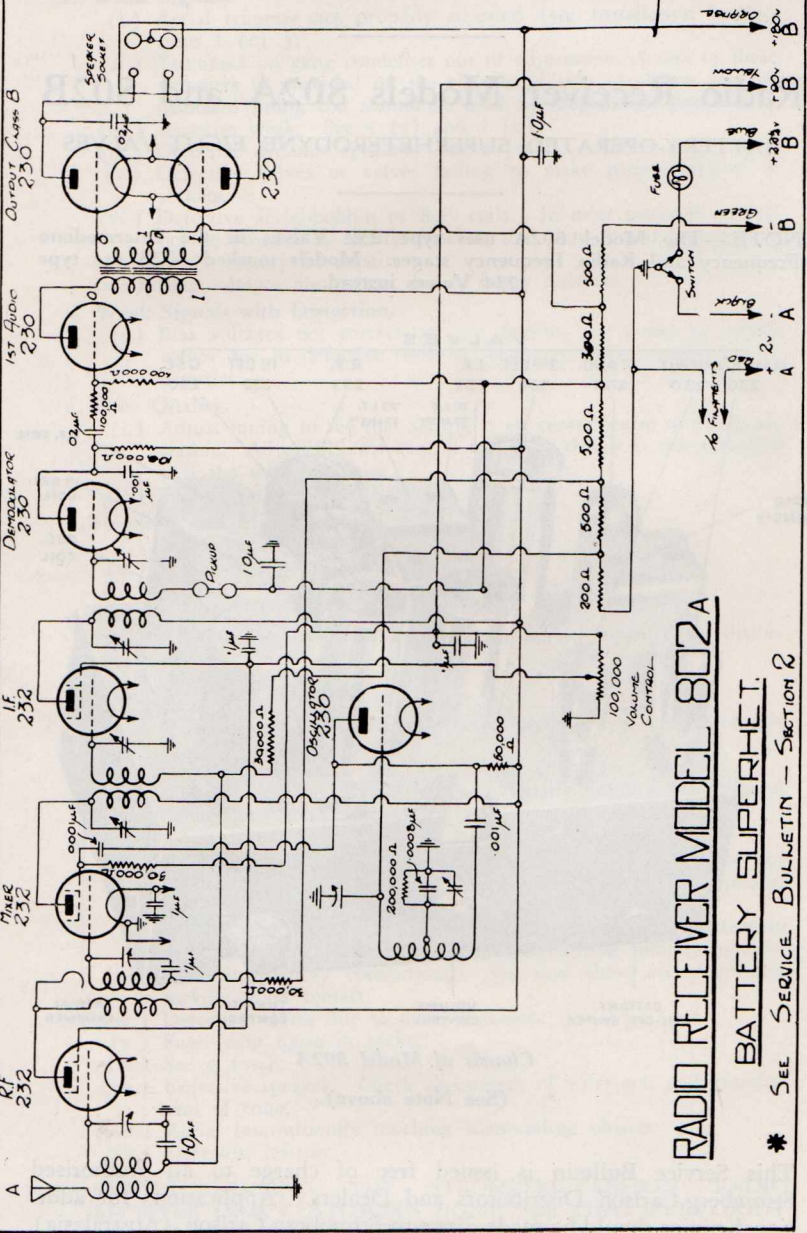

RADIO RECEIVER MODEL 802A

BATTERY SUPERHET.

* SEE SERVICE BULLETIN - SECTION 2

Radio Receiver Models 802A and 802B

BATTERY-OPERATED, SUPERHETERODYNE, EIGHT VALVES

(The 802A uses Type 232 Valves in the Intermediate Frequency and Radio Frequency stages, but the 802B uses 234 instead—see paragraph 2 on page 5).

This Receiver is designed specially for satisfactory service, with low battery current consumption, in areas where electric power is not available. The Model 802 has a sufficient sensitivity over the whole wave-length band to ensure daylight reception with satisfactory volume and clarity and, since it incorporates the well known superheterodyne principle, the selectivity is such that broadcast stations may be received without interference and overlapping. It uses one tuned radio stage, oscillator, two intermediate frequency stages feeding into a detector and one audio stage which drives two 230 type valves in "Class B" amplification and comprises eight valves in all.

1. GENERAL INSTALLATION INSTRUCTIONS:—

(a) Aerial and Earth.

The usual procedure of a well-insulated aerial and a short lead to an efficient earth should be followed. The 802 Receiver is a very sensitive instrument and will operate satisfactorily on an indoor aerial. However, it is strongly recommended that 40 to 60 feet of outdoor aerial be used, since such an aerial will transfer greater signal strength to the receiver. This condition allows the volume control to be turned back, resulting in less background of noise and interference and, at the same time, economises in B battery consumption.

(b) Lay-Out of Components.

For the lay-out of components appearing on the top of the chassis reference should be made to the photograph which appears on Page 1.

(c) Aerial Trimmer.

After installation this Model should be finally adjusted to work at maximum efficiency with the aerial to be used.

To do this proceed as follows:—

Tune the receiver to some station around the low wave-length end of the scale—say, 200 to 250 metres—turn the volume control down until the incoming signal is just audible then adjust by hand the small trimmer on the right-hand side of the chassis until a point of maximum signal is obtained. Once obtained, this adjustment should not be altered.

The tuning adjustments on the gang capacitor (variable tuning condenser) and the trimmer capacitors on the Intermediate Frequency Transformers (tuned to 175 k.c.) are adjusted and sealed at the factory at the time of calibration. These adjustments should on no account be touched or the seals broken unless a specially calibrated oscillator and indicating instrument are to hand whereby such adjustments can be successfully carried out. In any repairs or adjustments the above remarks in regard to the gang capacitor and intermediate transformers should be carefully noted.

STROMBERG CARLSON (AUSTRALASIA) LIMITED SYDNEY AUSTRALIA	DRAWING NO
CHARGES	DRAWN W.B. EXAMINED S.T.A. APPROVED DIRECTOR DATE 26-7-32

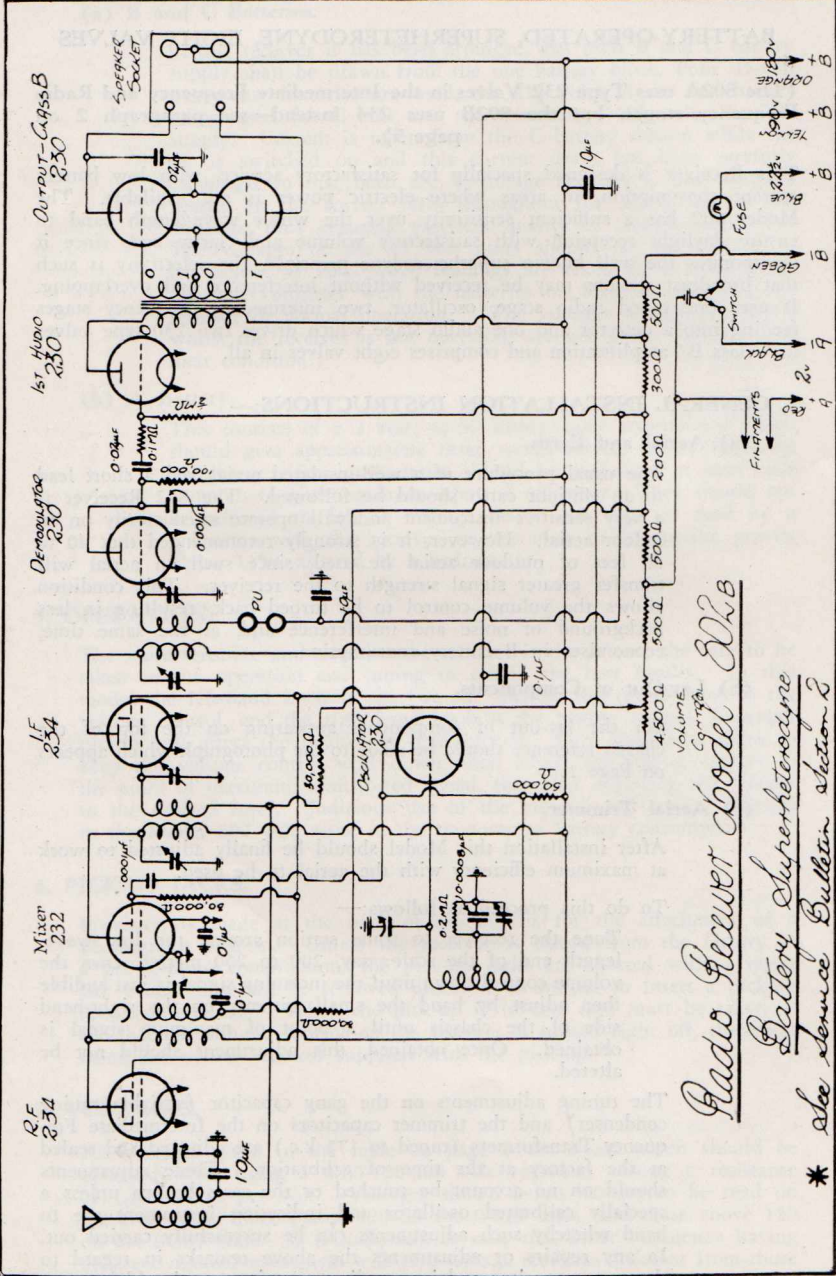

Radio Receiver Model 22B
 Battery Superheterodyne
 * See Service Bulletin Station 2

STROMBERG - CARLSON

SERVICE BULLETIN No. 802 (Continued)

Page 5

(d) Batteries.

- (i.) *A Battery*.—This consists of a 2 volt, 40-60 ampere-hour accumulator.
- (ii.) *B and C Batteries*.—These comprise 4 heavy duty 45 volt dry cells.

To join the battery leads correctly to the batteries, reference should be made to the Instruction Card which accompanies every Model 802. For further details of current consumption, etc., see 4 (a) and 4 (b) of this Bulletin.

The four B batteries may be housed in the back of the cabinet on the lower shelf, two on the right and two on the left-hand side of the loud speaker. The A battery may then be placed in between the B batteries or on the floor immediately behind the cabinet.

(e) Fuse Lamp.

As soon as the battery connections have been carefully checked, screw the Fuse Lamp into the socket as indicated on the Instruction Card. The purpose of the Fuse Lamp is to protect the valves in cases where the A and B battery leads have become inadvertently reversed. It should be noted that the receiver will not operate if this lamp is missing, making bad contact or burnt out.

2. VALVES.

All Battery-operated Receivers leaving the factory are supplied with valves which have been tested and matched to the receiver which they accompany. Since these valves are less robust than the A.C. type of valves they are not shipped in the sockets of the chassis but are carefully packed to avoid unnecessary jolting in transit. The photograph on page 1 shows the type and function of the valves and their exact location.

It should be noted that the manufacturer reserves the right to vary without notice the types of valves used in the Model 802 as per the following schedule. These variations will be recognised by the letters A and B being suffixed to the model number.

Function of Valve.	Model 802A.	Model 802B.
Radio Frequency	232	234
Inter. Frequency	232	234
Mixer	232	232
Oscillator	230	230
2nd Detector	230	230
1st Audio	230	230
"Class B" Pushpull	230 }	230 }
Output	230 }	230 }

3. SPEAKER.

The Speaker in this model is the Dynamic or moving coil type and is matched to the "Class B" push-pull output from two 230 Type valves. The combination of a dynamic speaker and "Class B" amplification in a battery-operated receiver is of recent development and for the first time allows a battery operated receiver to operate with output, power and fidelity comparable with all-electric model, at the same time considerably conserving the battery consumption.

STROMBERG - CARLSON

Page 6 **SERVICE BULLETIN No. 802 (Continued)**

4. BATTERIES:—

(a) B and C Batteries.

In this receiver it has been arranged that both B and C battery supply shall be drawn from the one battery block. Four 45-volt heavy-duty batteries are used, the $22\frac{1}{2}$ volts in the first battery being used for C bias and the remaining $157\frac{1}{2}$ volts for "B" supply. Current is taken from the C battery section while the set is switched on and this current drain has been carefully calculated so that both the B voltage and the C bias voltages remain in the correct ratio throughout the useful life of the batteries, thus ensuring excellent quality of reproduction.

The voltages of the 45 volt units should not be allowed to fall below 35 volts when readings are taken on a 1,000 ohms per volt voltmeter with the batteries on load, i.e., feeding the receiver in normal operation. (The voltages of batteries taken whilst the receiver is not operating are not a true indication of their condition.)

(b) A Battery.

This consists of a 2 volt, 40-60 ampere-hour accumulator which should give approximately three weeks service before requiring a recharge. Storage batteries should be re-charged at least once a month to give maximum life and efficiency. They should not be allowed to fall in voltage below 1.8 volts as read by a voltmeter with the receiver in operation or in specific gravity below 1150, as read by a hydrometer.

5. OPERATION.

The more sensitive and selective the receiver is the greater the care to be taken in the operation and tuning to obtain the best results. In this model the left-hand knob is the "on-off" switch, the centre knob is the volume control, and the right-hand knob is the tuning control. Improper tuning will affect the quality of reproduction. Care should be taken to keep the volume control well down, then adjust the tuning control to the point of maximum undistorted signal, thereafter adjusting the volume to the desired level. Judicious use of the volume and tuning controls in the Model 802 will assist in the economy of battery consumption.

6. PICK-UP JACKS.

Provision is made at the back of the chassis for the attachment of a phonograph pick-up. Unless the receiver is issued from the factory as a phono-radio combination, the pick-up jacks are shorted with a metal bar which must not be removed unless it is desired to insert a pick-up into the terminals. When the pick-up is in use, care must be taken to see that the volume control on the receiver is turned right off, thereafter using the volume control supplied with the pick-up.

7. VOLTAGES.

All voltages given in the table on page 7 are those which should be obtained when using a 0-60-120-300 volt voltmeter having a resistance of 1,000 ohms per volt. Voltages shown below 60 are to be read on the 0-60 scale, those below 120 on the 0-120 scale, and those above 120 on the 0-300 scale. It is important to note that other voltmeters having different internal resistances will give voltage readings different from those mentioned in the following table. Therefore a 1,000 ohm per volt voltmeter should be used.

STROMBERG - CARLSON

SERVICE BULLETIN No. 802 (Continued) Page 7

7. VOLTAGES (Continued).

Valve	Fila- ment	Bias (Grid)	Screen	Plate Volts	Plate Current
RF		(232) (234)			
232 or 234	2.0	2 2 (a) 22 (b)	67.5	157.5	1.5 m.a. (a) Nearly zero (b)
Mixer					
232	2.0	5	67.5	157.5	0.2 m.a.
Oscillator					
230	2.0	0	—	60-80	1 m.a.
Intermediate Frequency		(232) (234)			
232 or 234	2.0	2 2 (a) 22 (b)	67.5	157.5	1.5 m.a. (a) Nearly zero (b)
2nd Detector (Demodu- lator)					
230	2.0	12v.	—	100	.2 m.a.
1st Audio					
230	2.0	As read on Divider (See circuit) 12v.	—	157.5	2 m.a.
Output Class B					
2 230	2.0	15v.	—	157.5	1 m.a. total with no Signal

(a) = Volume control full on.

(b) = Volume control in "off" position.

Bias voltages given are those measured at valve sockets. Actual bias voltages measured on bias potential divider (see circuit) are:—

R.F. and I.F.	(232) 3 volts (234) 3 to 22 volts
Mixer	7.5 volts
2nd Detector	12 volts
Audio	12 volts
Output	15 volts

8. FAULTS:—

A list of probable faults with their causes is given below. Having located the fault it is necessary to adjust or repair the component in question or if beyond repair, to remove and replace it with a good component.

a. No Signals.

- (i.) Examine battery connections and battery switch on receiver, also battery cable.
- (ii.) Speaker plug not properly in socket or failing to make contact.
- (iii.) Valves failing to make contact in sockets.
- (iv.) Defective valves.
- (v.) Defective dynamic speaker due to disconnection in transformer or voice coil.
- (vi.) Defective by-pass condenser.
- (vii.) Resistor or condenser shorting to frame or burnt out.
- (viii.) Fuse Lamp not in socket, making faulty contact or burnt out.

b. No Signals When Audio End Appears in Good Order.

- (i.) Open circuit in volume control.
- (ii.) Intermediate frequency transformer shorting to frame or open circuit.
- (iii.) Defective oscillator valve.
- (iv.) Defective resistor in plate circuit of oscillator valve or defective grid resistor in oscillator circuit.
- (v.) Defective resistor in grid circuit of mixer valve.
- (vi.) Defective oscillator coil or R.F. coils. See c (vi.)

STROMBERG - CARLSON

Page 8

SERVICE BULLETIN No. 802 (Continued)

8. FAULTS (Continued):—

- (vii.) Fuse lamp blown or not making contact in socket.
- (viii.) Pick-up shorting bar missing or making defective contact.
- c. Weak Signals.**
 - (i.) Aerial trimmer not properly adjusted (see Installation Instructions 1 (c)).
 - (ii.) Trimmers on gang condenser out of adjustment. Access to these trimmers is provided on the right-hand side of chassis and an insulated lining rod should be used for adjustment purposes.
 - (iii.) Batteries weak. See 4 (a) and 4 (b).
 - (iv.) Defective dynamic speaker. See a (v.).
 - (v.) Defective valves or valves failing to make proper contact in sockets.
 - (vi.) Defective aerial-bobbin or R.F. coils. In most instances it will not be possible to rectify these on site; they should be returned to the factory for repair.
 - (vii.) Bias voltages not correct due to faulty resistors.
- d. Weak Signals with Distortion.**
 - (i.) Bias voltages not correct on 2nd detector, 1st audio or output valves due to defective resistors, defective audio transformer or batteries.
- e. Poor Quality.**
 - (i.) Adjust tuning to see that setting is on central point of broadcast station. Adjust volume control to ensure that it is not advanced past the overload point.
 - (ii.) Fading (atmospheric).
- f. Howling and Microphonism.**
 - (i.) Defective valves.
 - (ii.) Defective speaker.
 - (iii.) Defective batteries.
- g. Fading.**
 - (i.) Natural (atmospheric) causes—may be accompanied by distortion.
 - (ii.) Defective valves.
 - (iii.) Broadcast station troubles.
 - (iv.) Defective aerial due to its periodic contact with nearby objects as a result of swinging.
 - (v.) Defective batteries. See 4 (a) and 4 (b).
 - (vi.) Loose or high resistance joints. Visually examine all soldered connections and, if necessary, test with a pair of pliers.
- h. Noise.**
 - (i.) Remove aerial and earth from receiver. If noise ceases the trouble is due to local interference—static, electric light plants, etc.
 - (ii.) Natural atmospheric disturbances such as static. Direct attention of user to this phenomenon particularly during summer months.
 - (iii.) Defective battery connections. See that these are clean and making good contact.
 - (iv.) Defective valves due to loose elements.
 - (v.) Fuse lamp loose in socket.
 - (vi.) See g (vi.).
 - (vii.) Defective speaker. Check adjustment of voice coil and examine rear of cone.
 - (viii.) Aerial intermittently touching surrounding objects.
 - (ix.) Defective resistor.

N.B.—BEFORE LEAVING THE STROMBERG-CARLSON RADIO RECEIVER IN A CUSTOMER'S HOME, SEE THAT EVERYBODY WHO IS LIKELY TO HANDLE THE RECEIVER FULLY UNDERSTANDS ITS OPERATION. BY SO DOING MANY UNNECESSARY SERVICE CALLS MAY BE AVOIDED.

Stromberg-Carlson

STROMBERG - CARLSON
SERVICE BULLETIN, No. 836.

Stromberg - Carlson Model 836 Superheterodyne

A.C.-D.C. DUAL WAVE
SEVEN VALVES AND RECTIFIER

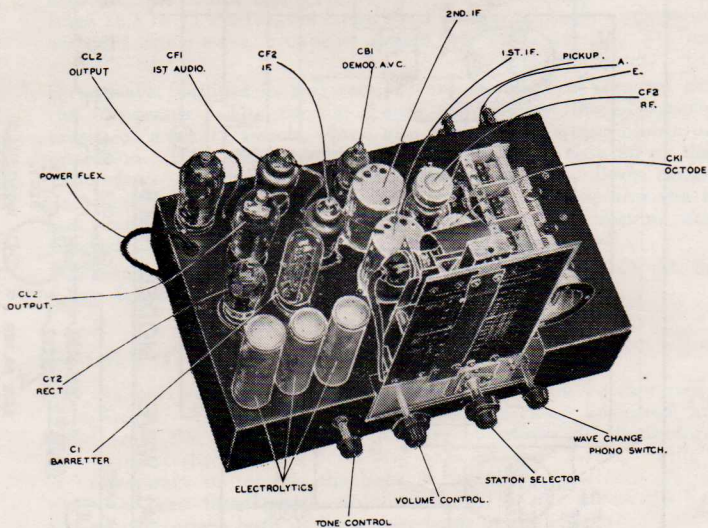

Chassis of 836 Model.

This Service Bulletin is issued free of charge to all authorised Stromberg-Carlson Dealers. Applications for additional copies should be made direct to the nearest Distributor.

Stromberg-Carlson (Australasia) Ltd. reserves the right to make changes in design details at any time without incurring any obligations to install same on radio receivers previously sold.

STROMBERG - CARLSON (AUSTRALASIA) LIMITED
 SYDNEY, AUSTRALIA

DRAWING No. 756

DRAWN *[Signature]*
 EXAMINED *[Signature]*
 APPROVED MGN. DIRECTOR
 DATE 5 - 11 - 35.

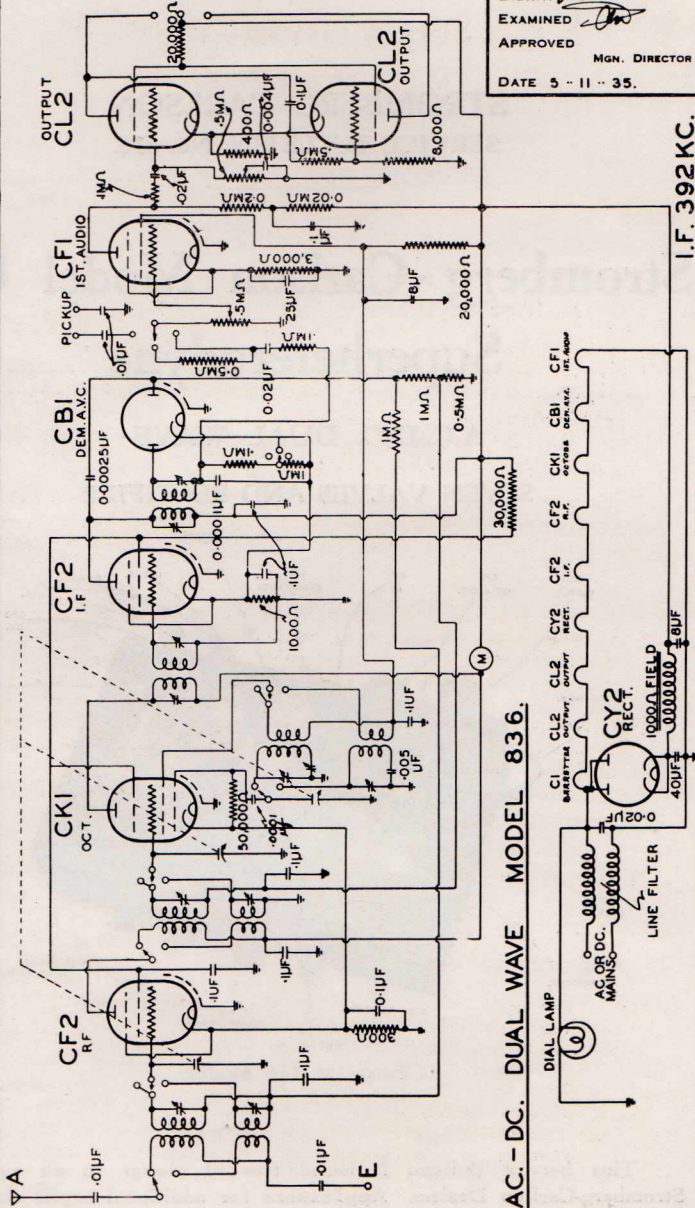

AC-DC. DUAL WAVE MODEL 836.

I.F. 392 KC.

Stromberg-Carlson Model 836

Superheterodyne

A.C.-D.C. DUAL WAVE SEVEN VALVES AND RECTIFIER

1. GENERAL DESCRIPTION OF RECEIVER:

This model employs the latest Superheterodyne principle, using Philip A.C.-D.C. series of valves, including the current limiting "Barretter" valve, which replaces the ballast resistor. It has been designed to operate with equal efficiency on both A.C. and D.C. mains. An efficient line filter is built into the receiver to reduce line noises, which are sometimes bad in D.C. areas.

The receiver may be used on line voltages ranging from 160 to 260 volts without any adjustment to the receiver.

The receiver is an 8-valve broadcast and short-wave receiver covering the broadcast band from 195 to 570 metres, and the short-wave band from 16.8 to 51 metres, the latter band including the five internationally assigned short-wave broadcast bands of 16.8, 19, 25, 31, and 49 metres.

Short-wave facilities in this receiver are designed as integral parts of the apparatus. The tuning ranges are quickly interchangeable by means of a rotary switch, which also controls the gramophone pick-up operation. Ease and convenience of operation are assured by the dual ratio drive and the open-faced Selectorlite dial. Both ranges are accurately calibrated—the short-wave band in metres, and the broadcast band in kilocycles. All important broadcast stations are also marked on the dial.

The short-wave range has the location of the 16.8, 19, 25, 31, and 49 metre bands indicated by heavy white lines.

2. INSTALLATION INSTRUCTIONS:

(a) As with any A.C./D.C. receiver, due care must be exercised in its installation. The aerial, radio earth, and pick-up terminals are isolated from the interior of the receiver by means of condensers, and they project through the protective back on the cabinet. This makes it unnecessary to remove the back to install the receiver. A two-pin plug has been fitted which, on the removal of the protective back on the cabinet, opens both of the power leads to the chassis.

Caution.

Should it be necessary, for any service reason, to remove the chassis from the cabinet and run it on a test bench, care must be taken that the earthed side of the supply line (normally the neutral for an A.C. service and the negative for D.C. service) is connected in such a manner that it goes to the chassis, and that the active side of the line does not. This can be readily ascertained by connecting a lamp or indicating meter of suitable type A.C. or D.C. between the chassis and earth before switching the receiver on. If the lamp lights or the meter registers, then the supply line will have to be reversed, otherwise it will be possible for the operator to receive a shock.

When making any adjustment, see that the power plug is completely removed from the socket of the supply source.

SERVICE BULLETIN, No. 836 (Continued)

5. SPEAKER:

The speaker in this Model is the Dynamic or moving coil type, and is matched to the output valve. The field coil being used at the date of issue of this Bulletin has a resistance of 1000 ohms. The speaker terminates in a seven-pin plug at the Receiver chassis.

THIS PLUG SHOULD NOT BE REMOVED WHILE THE CURRENT IS TURNED ON.

6. PICK-UP JACKS:

Provision is made on the back of the chassis for the attachment of a Phonograph Pick-up. The pick-up is brought into operation by turning the wave change switch fully to the left. The operation of the switch also removes any possibility of any radio programmes being heard while the pick-up is in use. The pick-up may be left permanently connected when the switch is changed back for radio operation.

The volume control on the Receiver may be used to regulate the audio output from the pick-up.

7 VOLTAGES:

Valve.	Plate.	Screen.	Cathode.
CF2, RF	225	85	3
CK1, Mixer	225	85	3
CF2, IF	225	85	2.5
CB1, Dem. A.V.C.	—	—	2.5
CF1, 1st Audio	25	100	3
CL2 + CL2, Output	220	110	20
CY2, Rectifier	—	—	300

All these voltages are measured from the above designated valve prongs to chassis with the line voltage at 240 volts.

The voltmeter used should have an internal resistance of 1000 ohms per volt.

8. COMPONENTS:

- | | | |
|----------------|-------------------|-------------------|
| 1. .01 mf. | 5. 100,000 ohms. | 13. .02 mf. |
| 2000 volt test | 6. 25 mf. | 100,000 ohms. |
| 2. .01 mf. | 7. 3000 ohms. | between 12A & |
| 2000 volt test | 8. — | 13B. |
| 3. .02 mf. | 9. .1 mf. | 14. 8000 ohms. |
| 4. .0001 mf. | 10. .1 mf. | 15. 500,000 ohms. |
| 100,000 ohms | 11. 20,000 ohms. | 16. .1 mf. |
| between 3B and | 12. 200,000 ohms. | 17. 20,000 ohms. |
| 4A. | | |

N B --BEFORE LEAVING A STROMBERG-CARLSON RADIO RECEIVER IN A CUSTOMER'S HOME, SEE THAT EVERYBODY WHO IS LIKELY TO HANDLE THE RECEIVER FULLY UNDERSTANDS ITS OPERATION. BY SO DOING MANY UNNECESSARY SERVICE CALLS WILL BE AVOIDED.

SERVICE BULLETIN NO. 200 (Continued)

Page 2

It is noted in this report that the engine is mounted on the front of the car and is driven by the front wheels. The engine is of the type known as a "front engine" and is of the type known as a "front engine".

The engine is mounted on the front of the car and is driven by the front wheels. The engine is of the type known as a "front engine" and is of the type known as a "front engine".

MOTOR JACK

The motor jack is a device which is used to raise the car from the ground. It is of the type known as a "motor jack" and is of the type known as a "motor jack".

The motor jack is a device which is used to raise the car from the ground. It is of the type known as a "motor jack" and is of the type known as a "motor jack".

VOLTAGER

Volts	Current	Power	Efficiency
100	1.00	100	100
110	1.10	121	110
120	1.20	144	120
130	1.30	169	130
140	1.40	196	140
150	1.50	225	150
160	1.60	256	160
170	1.70	289	170
180	1.80	324	180
190	1.90	361	190
200	2.00	400	200

The voltage regulator is a device which is used to regulate the voltage of the battery. It is of the type known as a "voltage regulator" and is of the type known as a "voltage regulator".

The voltage regulator is a device which is used to regulate the voltage of the battery. It is of the type known as a "voltage regulator" and is of the type known as a "voltage regulator".

COMMENTS

1. The engine is of the type known as a "front engine" and is of the type known as a "front engine".
2. The motor jack is a device which is used to raise the car from the ground. It is of the type known as a "motor jack" and is of the type known as a "motor jack".
3. The voltage regulator is a device which is used to regulate the voltage of the battery. It is of the type known as a "voltage regulator" and is of the type known as a "voltage regulator".
4. The battery is of the type known as a "lead-acid battery" and is of the type known as a "lead-acid battery".
5. The car is of the type known as a "sedan" and is of the type known as a "sedan".

It is noted in this report that the engine is mounted on the front of the car and is driven by the front wheels. The engine is of the type known as a "front engine" and is of the type known as a "front engine".

Stromberg-Carlson

STROMBERG-CARLSON
SERVICE BULLETIN, No. 888.

Stromberg-Carlson Model 888 Superheterodyne

DUAL-WAVE BATTERY-OPERATED RECEIVER.

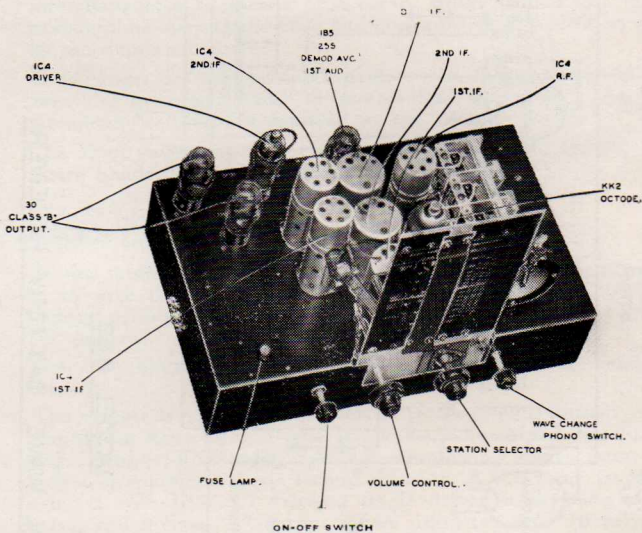

Chassis of Model 888.

This Service Bulletin is issued free of charge to all authorised Stromberg-Carlson Dealers. Applications for additional copies should be made direct to the nearest Distributor.

Stromberg-Carlson (Australasia) Ltd. reserves the right to make changes in design details at any time without incurring any obligations to install same on radio receivers previously sold.

Stromberg-Carlson Model 888 Superheterodyne

DUAL-WAVE BATTERY-OPERATED RECEIVER.

1. GENERAL DESCRIPTION OF RECEIVER:

This 8-valve, two-band battery-operated superheterodyne Receiver provides excellent reception of both standard wave and short-wave broadcasting stations. One band is the usual broadcast band from 200 to 500 metres, and the other a short-wave band from 16.5 to 51 metres. This latter band includes the five important internationally assigned short-wave broadcast bands at 16.8, 19, 25, 31 and 49 metres, respectively.

High sensitivity, excellent selectivity, automatic volume control, and good fidelity characterise this receiver. The tuning ranges are quickly interchangeable by means of a rotary switch, which also controls the gramophone operation. Ease and convenience of operation are assured by the dual ratio drive.

Both ranges are accurately calibrated—the short-wave band in metres, and the broadcast band in metres and kilocycles. All important broadcast stations are marked on the dial.

The short-wave range has the location of the 16.8, 19, 25, 31 and 49 metre bands indicated by heavy white lines.

2. DESCRIPTION OF ELECTRICAL CIRCUIT:

In this model, the valves have been chosen and the circuit so designed as to give the greatest efficiency consistent with low "A" and "B" battery consumption. The eight valves are operated at 2 volts and .78 amperes.

The "B" battery drain is approximately 13 milliamperes standing current.

The circuit is of the superheterodyne type, and consists of an R.F. amplifying stage using a type IC4 valve, a combined detector-oscillator stage using a KK2 valve, two I.F. amplifying stages using type IC4 valves, a combined diode second detector, A.V.C. and 1st audio stage using a type IB5/25S valve, a single driver stage using a type IC4 valve, and a class "B" output system using two type 30 valves.

3. INSTALLATION INSTRUCTIONS:

(a) Aerial.

The sensitivity of this model is such that for broadcasting reception a well-insulated wire about 20 or 30 feet in length, placed along the picture moulding in a room, or beneath the carpet, will prove satisfactory. Care should be taken to place all such indoor aerials as far away as possible from electric light or power conduits, and, in particular, clear of all unshielded flexible leads, since these latter are prolific radiators of undesirable electrical impulses.

An outdoor aerial is the most efficient, and is strongly recommended, especially for long-distance daylight reception on the broadcast band. The length of this aerial should be from 30 to 50 feet. In noisy areas

SERVICE BULLETIN, No. 888 (Continued)

Page 4

(due to electrical interference) the aerial should be erected as far as possible from and at right-angles to any electric power or light mains. As a further precaution against undesirable pick-up, the lead-in should be a special shielded type as employed in the "Stromberg-Carlson Aerial Noise Eliminator Kit." Details of this type of aerial may be had on application to Stromberg-Carlson (Australasia) Limited.

Do not use shielded lead-in wire for short-wave reception.

(b) Earth.

The chassis should be connected to earth by means of an insulated wire attached to a water pipe by an approved clamp. It is preferable to connect the earth lead to the last section of the pipe where it enters the ground, thus avoiding the high resistance contacts at the joints. Should a water system not be available, an efficient earth may be obtained by driving a metal pipe or burying about four square feet of metal sheeting in moist earth; the connection to the metal should preferably be soldered.

(c) Batteries.

(i) "A" battery.—This consists of a 2-volt 40-60 ampere-hour accumulator.

(ii.) "B" and "C" batteries.—these comprise 4 heavy duty or super 45-volt batteries.

To join the battery leads correctly to the batteries, reference should be made to the designation tabs to the leads and to the colour code, as shown in the circuit diagram on Page 2 hereof.

The four "B" batteries may be housed in the back of the cabinet on the lower shelf—two on the right, and two on the left hand side of the loud-speaker.

The "A" battery may then be placed in between the "B" batteries, or on the floor immediately behind the cabinet.

(d) Trimmer Adjustments.

The trimmer capacitors on the variable condenser, coil assembly, and the trimmer capacitors on the Intermediate Frequency Transformers (tuned to 392 k.c.) are adjusted and sealed at the factory at the time of calibration. These adjustments should on no account be touched or seals broken unless a specially calibrated oscillator and indicating instrument are available, whereby such adjustments can be successfully carried out.

In any repairs or adjustments, the above remarks in regard to the coil assembly and intermediate transformer should be carefully noted.

4. OPERATION:**(a) Battery Switch.**

A three position operating switch is used. When turned fully to the left, the receiver is switched off; both the "A" and "B" battery supplies being disconnected. When turned fully to the right, the receiver is ready to operate, and a pilot light is switched on. After tuning to the required station, the switch should then be turned to the centre position. This will extinguish the pilot light only, so removing drain from the battery, and the set will operate in the normal manner.

(b) Automatic Volume Control.

This Model is so designed that the signal voltages fed to the audio system tend to adjust themselves to a constant level. This signal level

is manually controlled and should be adjusted to the desired volume on a station of moderate or high power. The automatic feature will then tend to maintain this volume at a constant level on different signals of wide variations in intensity.

The effects of fading being thus reduced to an absolute minimum, constant attention to the volume control is obviated, especially on the reception of weak and distant stations.

5. PICK-UP JACK:

Provision is made on the back of the chassis for the attachment of a phonograph pick-up. The pick-up is brought into operation by turning the wave change switch fully to the left. The operation of the switch also removes any possibility of any radio programmes being heard while the pick-up is in use. The pick-up may be left permanently connected when the switch is changed back for radio operation.

6. VOLTAGES:

Valve.	165	Screen.	Bias.
IC4 RF	165	50	Nil
KK2 Octode, Pentode Section	165	50	Nil
KK2 Oscillator Section	165	—	—
IC4 1st IF	165	50	Nil
IC4 2nd IF	165	50	-.75
IB5, 25 S: Dem. Avc. 1st Audio	60	—	Nil
IC4 Driver	165	165	-11
30's Class B	165	—	-14

All screens are series fed from maximum high tension through 50,000 ohms.

7. COMPONENTS:

The following list of components is given to facilitate the servicing of the receiver and as a guide to replacement.

The numbers refer to the position of the components on the assembly panel.

- | | |
|------------------|------------------|
| 1. .01 mf. | 6. 200,000 ohms. |
| 2. .1 mf. | 7. .0001 mf. |
| 3. 3000 ohms. | 8. 100,000 ohms. |
| 4. 200,000 ohms. | 9. .0001 mf. |
| 5. .02 mf. | 10. 50,000 ohms. |

N.B --BEFORE LEAVING A STROMBERG-CARLSON RADIO RECEIVER IN A CUSTOMER'S HOME, SEE THAT EVERYBODY WHO IS LIKELY TO HANDLE THE RECEIVER FULLY UNDERSTANDS ITS OPERATION. BY SO DOING MANY UNNECESSARY SERVICE CALLS WILL BE AVOIDED.

STROMBERG-CARLSON (Continued)

The following information is furnished for the purpose of providing a basis for the determination of the amount of the dividend to be paid to the shareholders of the corporation.

The following information is furnished for the purpose of providing a basis for the determination of the amount of the dividend to be paid to the shareholders of the corporation.

Year	Dividend	Total
1934	100.00	100.00
1935	100.00	100.00
1936	100.00	100.00
1937	100.00	100.00
1938	100.00	100.00
1939	100.00	100.00
1940	100.00	100.00
1941	100.00	100.00
1942	100.00	100.00
1943	100.00	100.00
1944	100.00	100.00
1945	100.00	100.00
1946	100.00	100.00
1947	100.00	100.00
1948	100.00	100.00
1949	100.00	100.00
1950	100.00	100.00
1951	100.00	100.00
1952	100.00	100.00
1953	100.00	100.00
1954	100.00	100.00
1955	100.00	100.00
1956	100.00	100.00
1957	100.00	100.00
1958	100.00	100.00
1959	100.00	100.00
1960	100.00	100.00
1961	100.00	100.00
1962	100.00	100.00
1963	100.00	100.00
1964	100.00	100.00
1965	100.00	100.00
1966	100.00	100.00
1967	100.00	100.00
1968	100.00	100.00
1969	100.00	100.00
1970	100.00	100.00
1971	100.00	100.00
1972	100.00	100.00
1973	100.00	100.00
1974	100.00	100.00
1975	100.00	100.00
1976	100.00	100.00
1977	100.00	100.00
1978	100.00	100.00
1979	100.00	100.00
1980	100.00	100.00
1981	100.00	100.00
1982	100.00	100.00
1983	100.00	100.00
1984	100.00	100.00
1985	100.00	100.00
1986	100.00	100.00
1987	100.00	100.00
1988	100.00	100.00
1989	100.00	100.00
1990	100.00	100.00
1991	100.00	100.00
1992	100.00	100.00
1993	100.00	100.00
1994	100.00	100.00
1995	100.00	100.00
1996	100.00	100.00
1997	100.00	100.00
1998	100.00	100.00
1999	100.00	100.00
2000	100.00	100.00
2001	100.00	100.00
2002	100.00	100.00
2003	100.00	100.00
2004	100.00	100.00
2005	100.00	100.00
2006	100.00	100.00
2007	100.00	100.00
2008	100.00	100.00
2009	100.00	100.00
2010	100.00	100.00
2011	100.00	100.00
2012	100.00	100.00
2013	100.00	100.00
2014	100.00	100.00
2015	100.00	100.00
2016	100.00	100.00
2017	100.00	100.00
2018	100.00	100.00
2019	100.00	100.00
2020	100.00	100.00
2021	100.00	100.00
2022	100.00	100.00
2023	100.00	100.00
2024	100.00	100.00
2025	100.00	100.00
2026	100.00	100.00
2027	100.00	100.00
2028	100.00	100.00
2029	100.00	100.00
2030	100.00	100.00

The following information is furnished for the purpose of providing a basis for the determination of the amount of the dividend to be paid to the shareholders of the corporation.

The following information is furnished for the purpose of providing a basis for the determination of the amount of the dividend to be paid to the shareholders of the corporation.

The following information is furnished for the purpose of providing a basis for the determination of the amount of the dividend to be paid to the shareholders of the corporation.

The following information is furnished for the purpose of providing a basis for the determination of the amount of the dividend to be paid to the shareholders of the corporation.

