

ATWATER  
KENT  
RADIO  
INSTRUCTION  
BOOK  
*Vol. 3*



# ATWATER KENT RADIO INSTRUCTION BOOK

Vol. 3

PART No. 7852

PRICE 50 CENTS

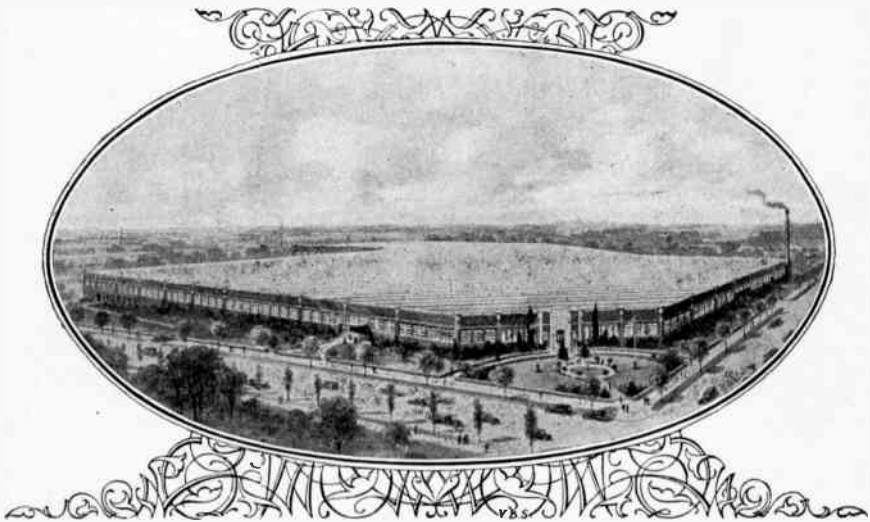

ATWATER KENT MFG. COMPANY

4700 Wissahickon Avenue

*Philadelphia*

## PREFACE

*This book has been prepared with the idea of helping owners of Atwater Kent Receiving Sets to get the most out of their radio installation with the least possible trouble and expense. We have endeavored to answer, before they are asked, most of the questions that arise in the minds of the beginner in Radio and many that might trouble an experienced operator.*

*We earnestly recommend that before you purchase any additional equipment or attempt to install and operate your Receiving Set, you read over most carefully PARTS I and II of this book.*

---

Copyright, 1926

Form 334. Printed in U. S. A., July, 1926

# Part I.

## INSTALLATION

### CHAPTER 1.

#### Equipment Necessary for Installing any Type of Atwater Kent Radio Receiving Set

**RADIO SPEAKER OR PHONOGRAPH ATTACHMENT.** A high grade receiving set is worthy of a high grade speaker—in fact the speaker or phonograph attachment that you select will have a very great deal to do with the success of your radio installation. For this reason we strongly recommend that you use an Atwater Kent Radio Speaker or Phonograph Attachment, with your receiving set. If you have already purchased another make of speaker or phonograph attachment, we suggest that you immediately arrange to try out an Atwater Kent, noting the improvement in the volume and quality of tone delivered by the Atwater Kent apparatus. See page 48. Section 1.

**TUBES FOR ALL MODELS.** 5-volt, UX or CX base,  $\frac{1}{4}$  ampere tubes are required for all Models. It is recommended that all tubes be tested by the dealer before delivery and it is essential that tubes used in the Radio Frequency and Detector tube sockets be of the same make or manufacture. Sec. 2.

**BATTERIES. FOR ALL MODELS.** Three kinds are necessary, viz: an "A" battery, a set of "B" batteries and a "C" battery. The "A" battery should be of the storage type, 6-volts, and 80, 90, 100 or 120 ampere-hour capacity, unless a trickle charger is used when batteries of smaller capacity may be used with success. For "B" batteries it is recommended that two (2) 45-volt, heavy duty, dry cell batteries be used. For a "C" battery, a  $4\frac{1}{2}$ -volt dry cell battery. Sec. 3.

**BATTERY CABLE FUSE BLOCK.** It is recommended that a fuse block having the approval of the Underwriters' Laboratories, and made up of from four to six plugs or cartridge fuses, be inserted between the ends of the battery cable wire and the "A" and "B" batteries. Fuses with two (2) ampere capacity should be used for the "A" battery wires and Fuses with one (1) ampere capacity should be used for the "B" battery wires. For further details see page 22. Sec. 4.

**USE OF POWER TUBE.** A  $\frac{1}{2}$  ampere power tube, using a 135 or 180 volts on the plate, can be used in the last audio stage if desired. This will require additional "B" and "C" batteries. For information see Sec. 6, page 39. Sec. 5.

**USE OF A SPECIAL DETECTOR TUBE.** A special  $\frac{1}{4}$  ampere detector tube may be used in the detector tube socket of all models. For further information see Sec. 4, page 38. Sec. 6.

## For an outside Antenna Installation

(See Illustration 9, Page 13)

- Sec. 7. **ANTENNA WIRE.** 100 feet of 7-strand No. 22 gauge, phosphor bronze or copper. Bronze wire is recommended, as it is less liable to stretch and sag.
- Sec. 8. **LEAD-IN AND GROUND WIRE.** No. 14 Rubber Covered, stranded, of sufficient length to reach from the antenna to the Receiving Set and from the Receiving Set to the ground, and also from the lightning arrester to its ground. Usually 50 feet is more than sufficient.
- Sec. 9. **GROUND CLAMPS.** Two (2). One used for grounding the set and the other for grounding the lightning arrester.
- Sec. 10. **LIGHTNING ARRESTER.** One that bears the approval of the Underwriters' Laboratories.
- Sec. 11. **INSULATORS.** (Strain Type.) Usually two are sufficient. They should be of the large size and preferably made of porcelain or glass.
- Sec. 12. **A PORCELAIN TUBE.** Usually 10 inches long, to be used for insulating the lead-in wire where it enters the building.
- Sec. 13. **INSURANCE UNDERWRITERS' CERTIFICATE OF INSPECTION.** In order that your radio installation may not affect the validity of your fire insurance policies, it is recommended that when your installation is complete, you secure a certificate of approval from the Insurance Underwriters having jurisdiction in your locality.

## For an inside Antenna Installation

- Sec. 14. **ANTENNA AND GROUND WIRE.** A sufficient length of some light weight insulated wire, either stranded or solid, such as No. 18 Bell Wire.
- Sec. 15. **GROUND CLAMP.** Only one is necessary as a lightning arrester and its ground, etc., are not required for an inside antenna installation.
- Sec. 16. **INSURANCE UNDERWRITERS' CERTIFICATE.** (See Sec. 13).

Identification of Model Number of Receiving Sets. If you are in doubt as to the Model Number of your set, refer to the serial number name plate. This name plate is located **inside** the lid of the Wooden Cabinet Sets, and on the **back** of the Model 35.

## CHAPTER 2.

## General Information About Antennas

**T**HE function of the antenna is to collect the electrical waves radiated from the various broadcasting stations and carry this electrical energy, via the antenna lead-in wire, to the receiving set. Sec. 1.

To quote a homely simile, we might liken the antenna to the gutter on your roof and the lead-in wire to the down spout or rain conductor. A short gutter will collect and deliver to the down spout but a small amount of water—a very long gutter will deliver too much water for the down spout to handle. A radio antenna that is *too short* will not collect enough electrical energy, broadcast from distant stations, to enable you to tune in the signals. An antenna that is *too long* will collect so much electrical energy sent out from nearby broadcasting stations, that you will be unable to tune them out—that is, your set will not be “selective.”

Again, referring to our simile, a gutter that drains a roof shaded by trees or other overhanging obstacles will not collect as much rain water as a gutter that drains a roof completely exposed to the elements, therefore your antenna should be raised as far as possible above trees, chimneys, etc., and the walls of your own, or adjoining buildings, so that it may have a chance to collect all the radio waves possible to collect.

Again, if a gutter is filled with leaves, dirt or ice, it will not deliver all the water to the down spout, for varying amounts will spill over the edge and drop to the ground. Likewise your antenna will not deliver all the electrical energy to your receiving set (through the lead-in wire), if it is so placed that it touches, *or is even too near to* (but not touching) other wires, metal roofs, gutters, chimneys, trees and the like, for the electricity will run from the antenna through these conductors to the ground, instead of to the ground through the lead-in wire and your receiving set.

This simile holds good for an inside as well as an outside antenna, for, instead of an inside antenna being affected by overhanging trees, nearby metal gutters, etc., it can be affected by nearby metal girders, metal lath, pipes, wires, etc., concealed in the walls of a building. Some suggestions for overcoming these difficulties are given under the section dealing with the installation of inside antennas.

Models, 20 Compact, 30 and 35 will function to best advantage when an **outside** antenna is used; while a properly installed **inside** antenna will usually give very satisfactory results when used with the Model 32.

Section 2. OUTSIDE ANTENNAS.

An excellent outside antenna for Atwater Kent Receiving Sets is one composed of a single wire 80 feet in length in a straight line, stretched at least 30 feet above the ground and at least 10 feet above all trees, roofs, chimneys, etc. over which it passes, and 10 feet away from all walls, trees and the like. The lead-in wire might be anywhere from 15 to 35 feet in length, or a combined length of antenna and lead-in wire of from 95 to 115 feet.

Unfortunately it is difficult to give definite instructions as to the antenna you should erect, for after all is said and done, the antenna you will install will depend mostly on your location and surroundings.

If you live out in the great open spaces, and at a considerable distance from broadcasting stations, you will no doubt find that an antenna which is considerably *longer* than 80 feet will give you most satisfactory results.

If, on the other hand, you live in a big city with its network of telephone, electric light and electric power wires, numerous local broadcasting stations and its many other forms of local interference, you will very likely get the most satisfactory results with an antenna which is considerably *shorter* than 80 feet in length.

Another determining factor is your physical location. That is to say, if your property is only 20 feet wide by 50 feet deep you cannot very well erect an antenna 80 feet long in a straight line—if the building you live in is only a few stories in height and is surrounded by towering buildings, you cannot be expected to raise your antenna 10 feet above their walls.

On the whole we recommend the installation of an antenna that is too long rather than too short, for, it is much easier to shorten an antenna after it is installed than it is to lengthen it in a straight line after it is installed. See illustration 39, page 38.

In order to assist you in selecting the type of outside antenna that most nearly fits your requirements, we give on the following pages several diagrammatic pictures of typical antenna installations.



## OUTSIDE ANTENNAS

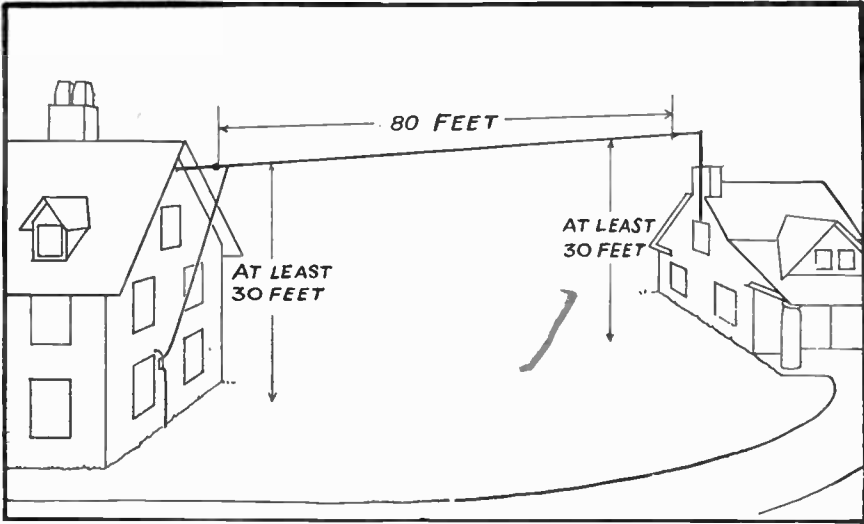

Illustration 1.

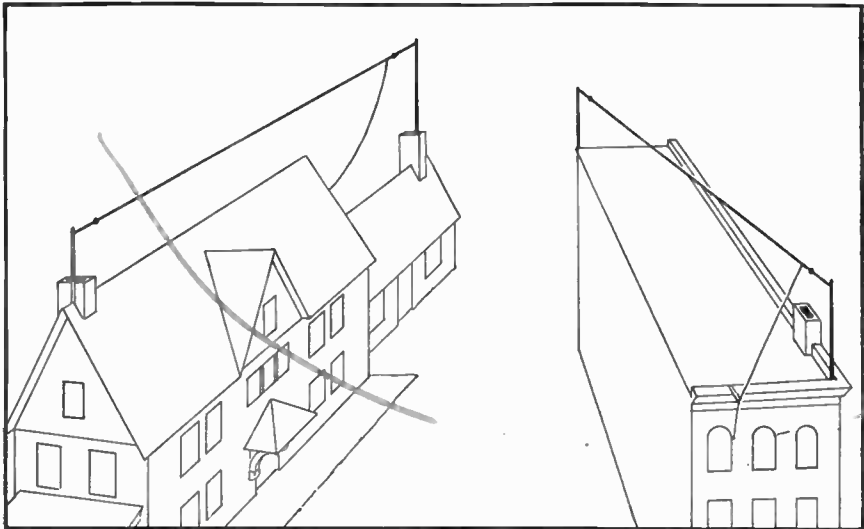

Illustration 2.

## OUTSIDE ANTENNAS

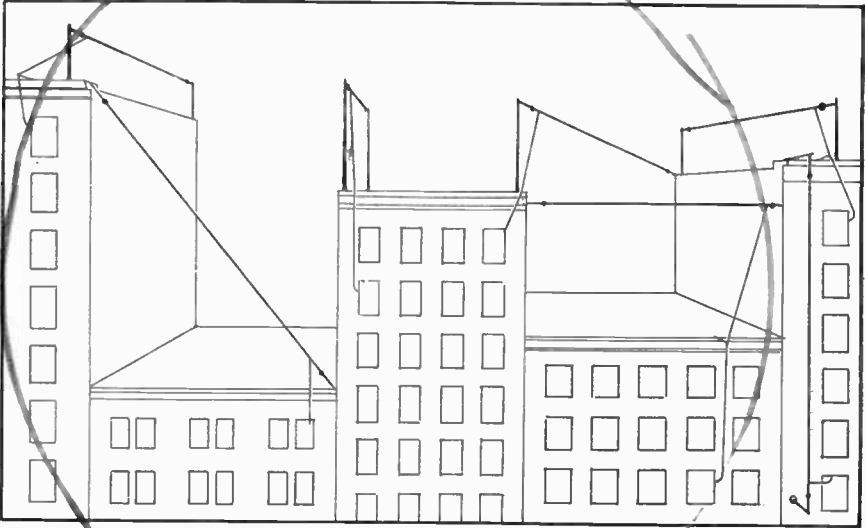

Illustration 3

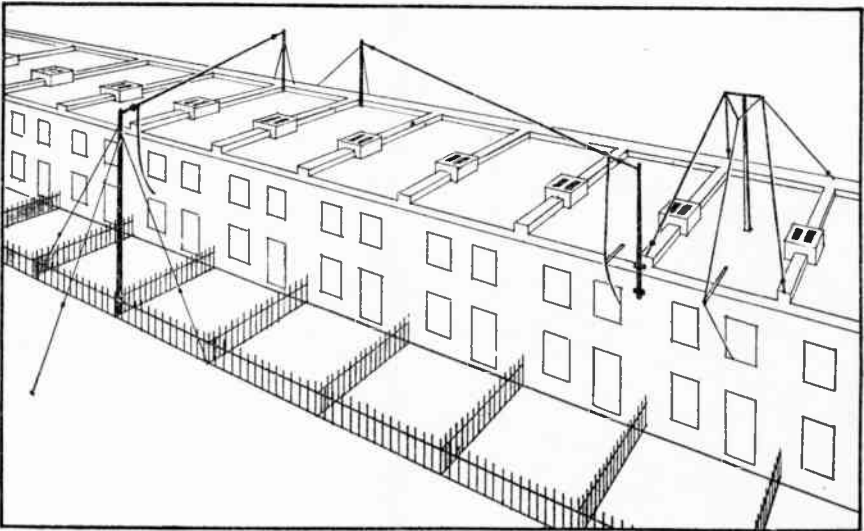

Illustration 4

## INSIDE ANTENNAS.

Sec. 3

Whenever possible we recommend a full sized, *outside* antenna but, where this is impossible, very good results can be obtained from a properly installed inside antenna. In planning an inside antenna, endeavor to place it as high as possible in the building—in the attic or in a room on the top floor of the building.

Illustrations 5 and 6 show respectively an attic and a top floor room installation, both of which have been quite successful. The type of antenna shown in Illustration 6 is also suitable for an attic installation.

In either case insulated wire is preferable, although not absolutely necessary, and the wires should be strung at least 2 feet 6 inches apart and 3 feet or more apart, if possible. In planning antennas of this character it should be remembered that doubling the number of wires does not double the effectiveness of the antenna. In other words, two wires each 40 feet in length or four wires each 20 feet in length are not the equal of a single wire 80 feet in length in a straight line. Hence it is desirable that the total length of the wires used should amount to considerably more than eighty feet, wherever this is possible.

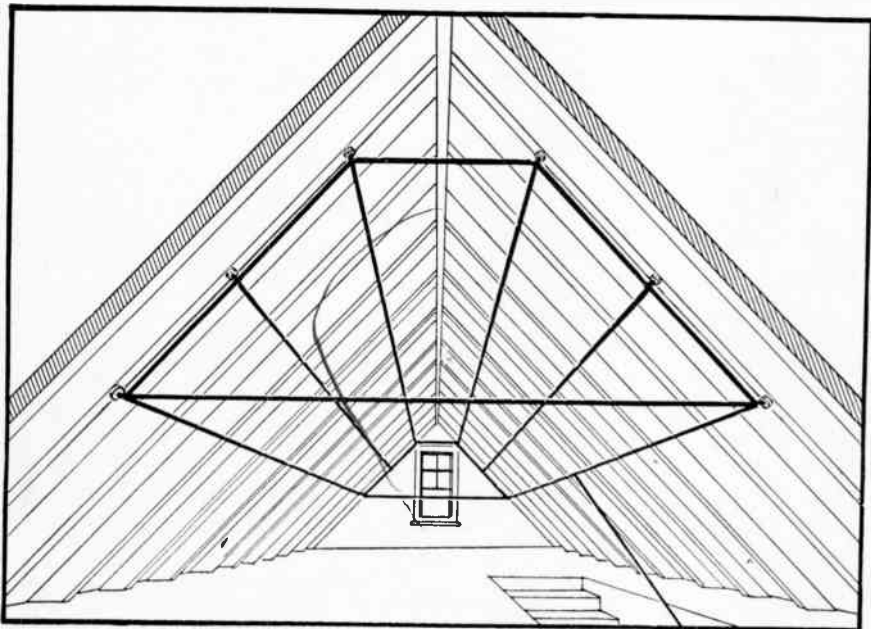

Illustration 5

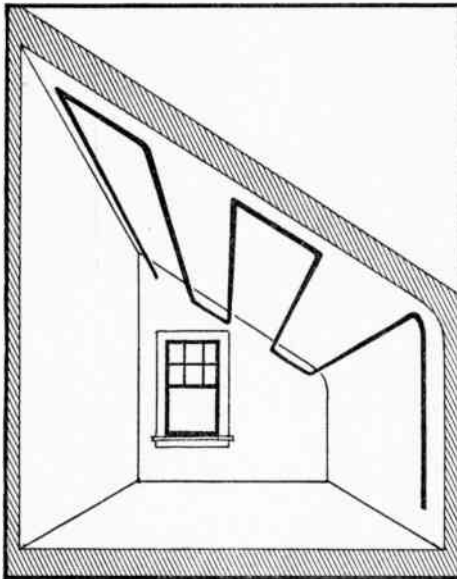

Illustration 6

In installing an antenna in an unfinished attic it is advisable to string the wires on porcelain insulators. *Do not allow the wires to touch electric light wires, and when it is necessary for the antenna wires to pass over or under electric light wires, they should be encased in porcelain tubes or other approved insulating material.*

Illustration 7 shows an excellent type of antenna for use in a Living Room or any other room of fairly large dimensions. Usually the antenna wire is laid along the top of a picture moulding and held in place with glass headed tacks or light wire nails. But it may also be tacked to the top of the base board.

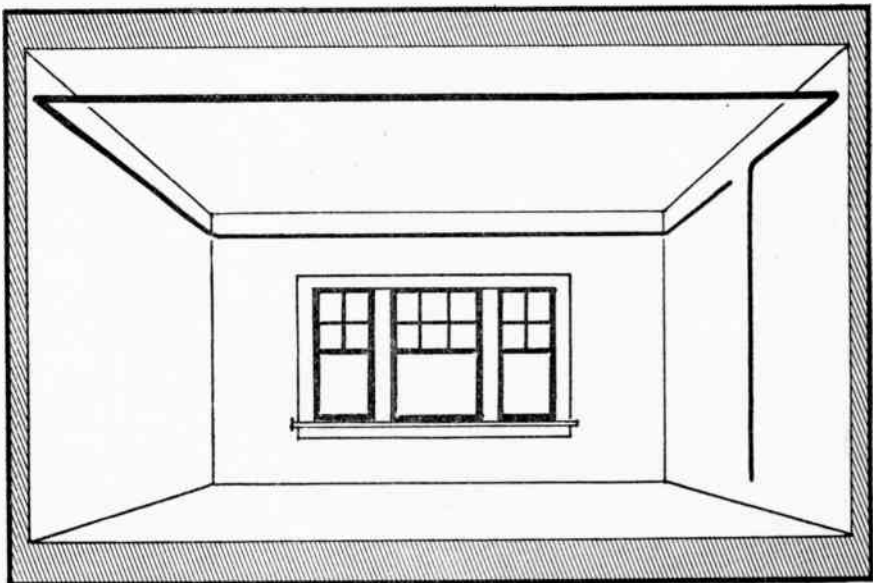

Illustration 7

Where there are several small rooms, it is often found practical to string the wire around the walls of several of the rooms, taking care that the wire does not cross itself at any point nor come closer to itself than the breadth of the average doorway.

Illustration 8 shows two other types of inside antennas, one—a square spiral under a rug and the other encircling the window casing. Both are particularly useful in a building of steel construction as they remove the antenna as far as possible from the steel girders that are built into the wall immediately above the picture moulding or below the base board.

If the spiral antenna is over 80 feet in length, it should give excellent results with all models of Atwater Kent Receiving Sets. If it is less than 80 feet, but longer than 25 feet, it should give satisfactory results with the Model 32. The antenna encircling the window casing should only be used with the Model 32. Other short antennas for the Model 32 will be found satisfactory, provided they are more than 25 feet in length.

The results obtained with all inside antennas and particularly the short ones, will depend to a large degree on the distance it is located above the ground (earth) and the amount of steel construction in the building.

For ground wire installation see Illustration 9, Page 13.

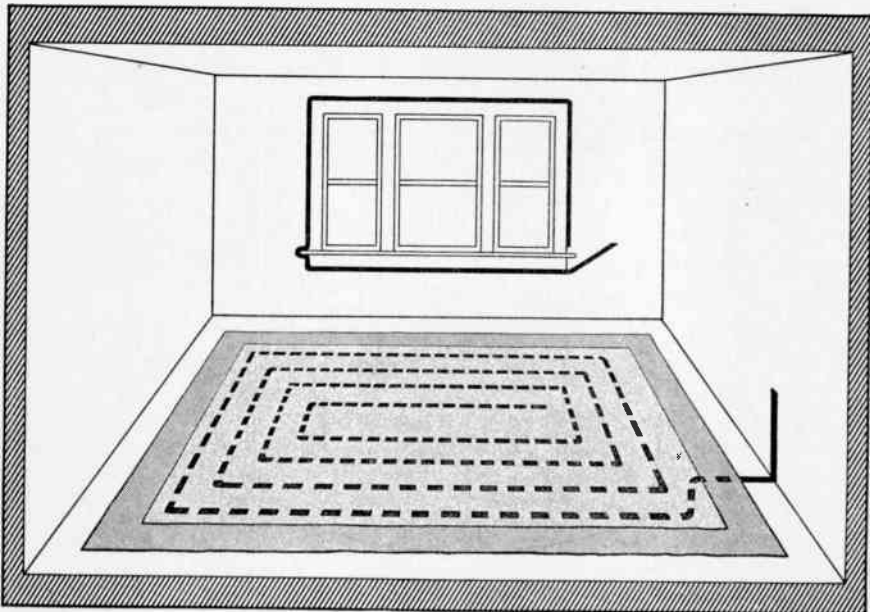

Illustration 8

Sec. 4. ERECTING AN OUTSIDE ANTENNA. (see Illustration 9).

In erecting your antenna, care should be taken to see that the antenna wire is tightly stretched, and that the screw eyes or other terminals be firmly attached to a non-moving surface. Otherwise your antenna will be apt to be broken down by an accumulation of ice or snow, or blown down in a gale.

For this reason trees are not a desirable anchorage for antenna terminals. If a tree is the only possible place to attach one end of your antenna, be sure to use a pulley and counter-weight. If long poles are used to support your antenna, they should be made rigid by the use of guy wires, or a pulley and counter-weight should be used.

The wheel of the pulley (P) should be of large diameter so that the continued movement of the rope over it will not quickly wear the rope through.

Usually the supporting wires CC are composed of pieces cut from the coil of antenna wire. They should be long enough to make the insulators BB at least two feet from the terminal supports DD, or nearby cornices, etc.

When a counter-balanced arrangement is used, the supporting wire C should be *as short as possible*, and the rope R long enough to place insulator B at least two feet beyond all nearby branches. If attached to a tree the supporting wire C should be incased in a piece of garden hose, or otherwise prevented from cutting into the bark.

The lead-in wire E should be soldered firmly to the antenna and the joint bound tightly with electric tape. It should be made to enter the building as far as possible above the ground and *should not be run near to the ground wire F*, nor near and parallel to metal gutters, rain-conductors, electric light and telephone wires, gas, water or heating pipes.

The lightning arrester's ground wire should follow as nearly as possible a straight line from the lightning arrester to its ground.

In most localities it is allowable to ground the lightning arrester on a metal pipe (or other metal object) embedded in the earth or on an exterior or interior water pipe. In order that you may conform to your local requirements, we recommend that you secure a copy of your local "Fire Underwriters' Regulations."

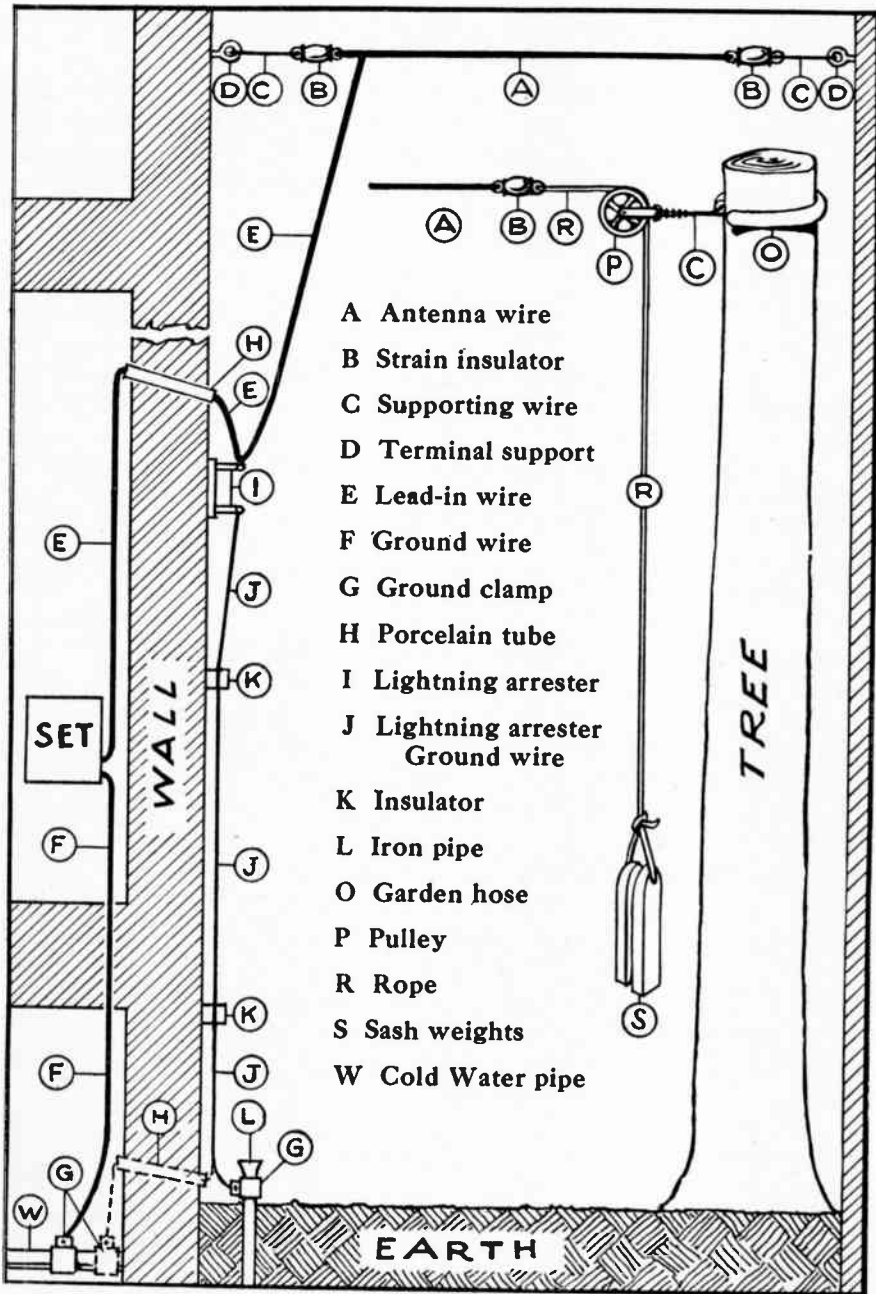

Illustration 9  
 DETAIL DRAWING OF AN OUTSIDE ANTENNA INSTALLATION

## CHAPTER 3.

### Installing the Receiving Set

Sec. 1. **LOCATING THE RECEIVING SET AND RADIO SPEAKER.** In the first place, the Receiving Set and Radio Speaker should be located in that part of the house or apartment where the whole family may have a chance to enjoy it. This usually means the living or sitting room, main hall, enclosed porch or in fact any place where the family and friends congregate.

In the second place, try to place the Receiving Set where it can be reached without the necessity of standing up or leaning over in an uncomfortable position. A small table, book-rack, piano bench, desk or other small piece of furniture will make an excellent place on which to put the Receiver, and it should be located near where artificial light is available, for use at night.

The speaker is usually located close to the receiving set, in order to have it near the operator when distant stations are being tuned in, although this is not absolutely necessary. By adding to the length of the cable supplied with the speaker or phonograph attachment, either may be placed in any part of the room. For further information see Part III, Sections 7 and 8.

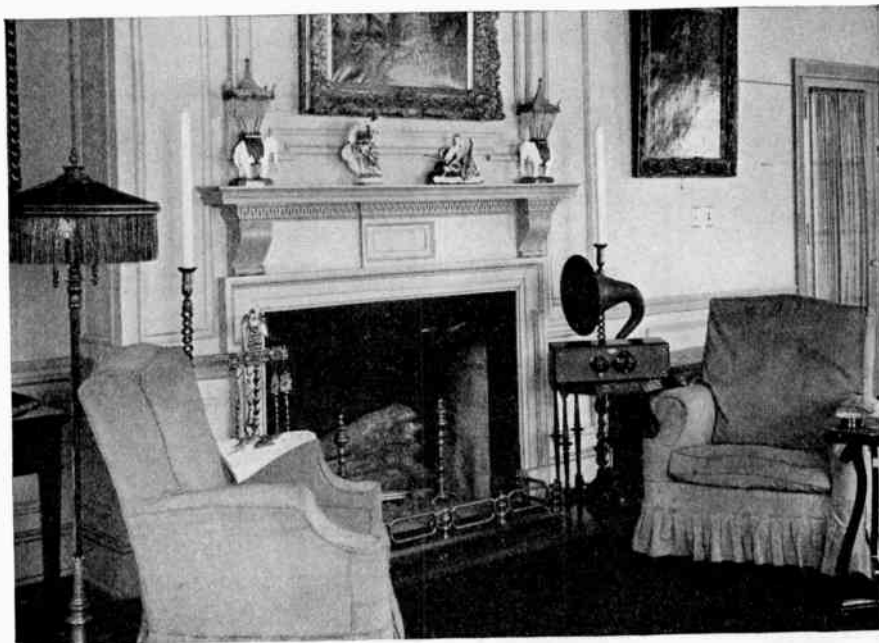

Illustration 10

In the home of Mary Roberts Rinehart—Set and Speaker are conveniently placed between the open fire place and the big arm chair.



In order to help you select a place to put your receiver, we give here-with several views showing how other owners of Atwater Kent Radio have installed their Receiving Sets and Speakers.



Illustration 11

In the home of Irvin Cobb (above) and Julian Street (at the right), the Model 20 Compact rests on a little end table.



Illustration 13



Illustration 12

An interesting setting in the home of Wallace Irwin.



Illustration 14

Booth Tarkington has placed his receiver in a corner of the hallway.

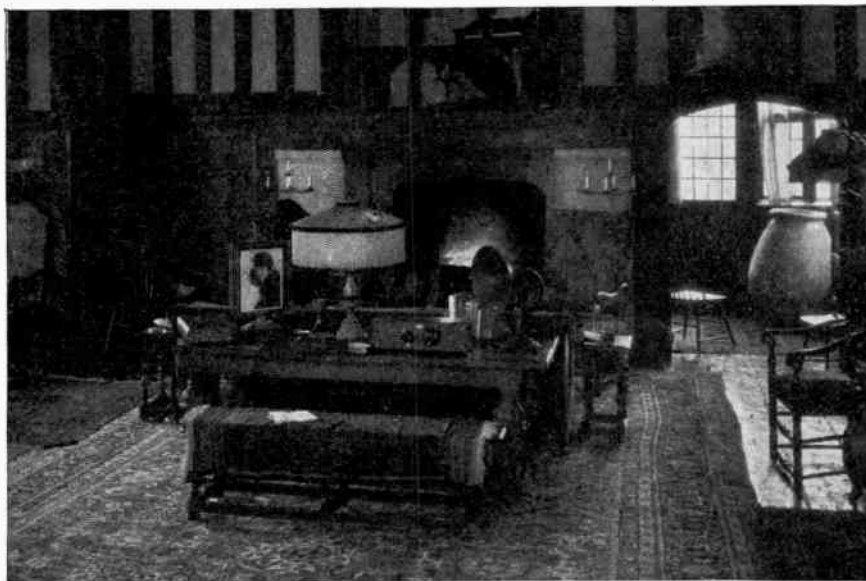

**Illustration 15**

On a corner of the big table, Clare Briggs, the Cartoonist, has placed his Model 30 with the Speaker close by.



**Illustration 16**

This unique and attractive setting is Burton Holmes' idea of a radio installation.

**LOCATING THE BATTERIES.** The best place to put the batteries Sec. 2. is in the cellar or basement, placing them immediately under the receiving set, so that they will be as near to it as possible.

If it is impracticable to locate the batteries in the cellar or basement, they may be concealed by placing them in an "Atwater Kent Battery Container" (see page 48 for full description) or back of a couch, in a closet, bookcase or other convenient place. However, we do not advise the placing of storage batteries in, or near fine furniture, unless special precautions are taken to guard against damage by the acid contained in all storage batteries.

**SPACE OCCUPIED BY "A," "B" AND "C" BATTERIES.** "A" Sec. 3. batteries must always be placed on their bottoms, and this must be done carefully so that no acid is spilled out. "A" batteries come in a variety of sizes, depending on the make and their ampere hour capacity. The average of the larger sizes are as follows: 9 inches high by 7 inches wide and from 9 to 12 inches long for 80 to 120 ampere hour capacity batteries. "Dry cell" "B" and "C" batteries may be placed in any of the positions shown in illustrations 17 to 21, inclusive. Wiring connections are explained and illustrated on pages 21, 22, 23 and 39.

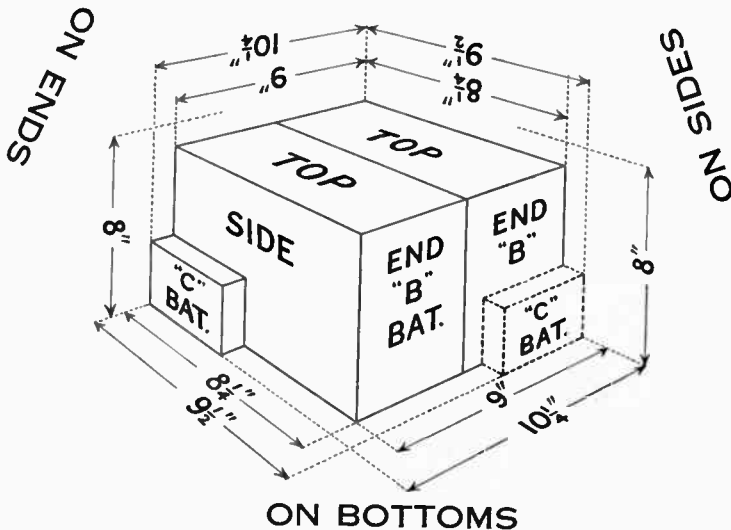

Illustration 17  
 TWO 45-VOLT, HEAVY DUTY "B" BATTERIES  
 AND ONE 4½-VOLT "C" BATTERY

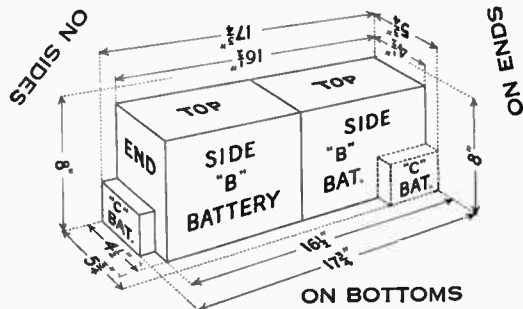

Illustration 18

TWO 45-VOLT, HEAVY DUTY, DRY CELL "B" BATTERIES  
ONE 4½-VOLT DRY CELL "C" BATTERY

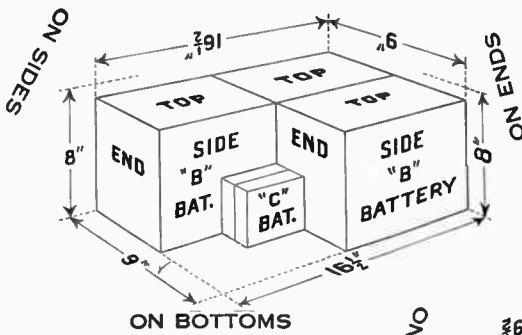

Illustration 19

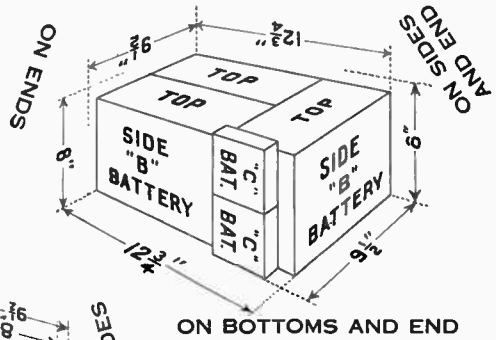

Illustration 20

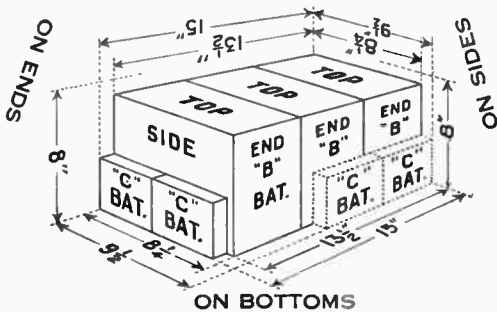

Illustration 21

THREE 45-VOLT, HEAVY DUTY, DRY CELL "B" BATTERIES  
AND TWO 4½-VOLT "C" BATTERIES

## Connecting the Speaker or Phonograph Attachment to Receiving Set. Sec. 4.

**For Special Information Regarding Connecting Speaker Cable and Antenna and Ground Wires to the Model 35, see Pages 24 and 25.**

### FOR MODELS 30 and 32

This is done by passing the terminals of the speaker cable through the hole in the back or end of the cabinet marked "Radio Speaker." (See illustration on pages 26 and 27.)

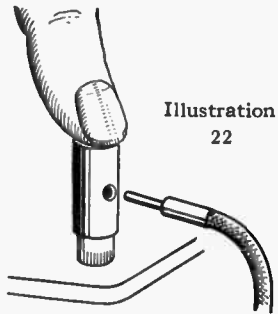

By pressing down on the top of the binding post, opposite the designation "Red Tracer Lead," a small hole will be opened in the side of the binding post. (Illustration 22.) Insert the end of the **red and black wire** in this hole and remove the pressure from the top of the post. It will spring up and lock the end of the wire securely in place. (Illustration 23.) Now follow the same method in connecting the "black lead" to its binding post.

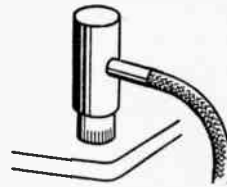

Illustration 23

### MODEL 20 COMPACT

In the Model 20 Compact, a special clip type binding post is used. Attachment of the Speaker wires is made through the single hole in the back of the Cabinet marked "Speaker," by pushing the terminals of the black wire and red-and-black wire into their respective spring clips located inside the cabinet. (Illustration 24).

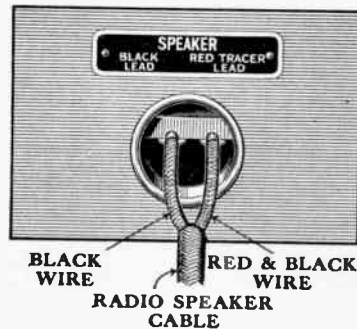

Illustration 24

### Sec. 5. Connecting the Antenna Lead-in to Receiving Set

Next, scrape off about  $\frac{1}{4}$  inch of insulation from the end of the "antenna lead-in wire," **scrape it clean and bright** and insert it in the hole in its binding post and then do the same with the "ground wire." For location of binding posts, see pages 26, 27 and 28.

### Sec. 6. CONNECTING RECEIVING SET TO GROUND. The next step is to attach one end of the ground wire to the binding post marked "GROUND." For location of binding posts, see pages 26, 27 and 28.

The remaining end of the ground wire should be attached to a *cold water pipe as near as possible to where it enters the building*. See illustration 9 on page 13. If this is impossible, use any convenient hot water or radiator pipe, *but never a gas pipe*. The objection to a hot water or radiator pipe is the fact that the current must flow through the entire heating system to reach the incoming cold water pipe and thence to the ground (earth) outside. The use of a gas pipe for a ground is against the rules of the Fire Underwriters.

To make a proper joint between ground wire and water pipe, file or scrape to shiny brightness, a band completely around the pipe, and clamp the wire, by means of the ground clamp, as tightly as possible on this spot, using screw driver and pliers or wrench.

**Connections to Antenna and ground binding posts are made as explained in Section 4, Page 19.**

### Sec. 7. RUNNING CABLE TO BATTERIES. If batteries are located in the cellar or basement, the battery cable can be run through the floor by boring a $\frac{1}{2}$ -inch hole through it. If in a closet, book-case or special battery container, run the battery cable along the floor close to the base board. The cable may be lengthened by splicing. If this be done all joints should be soldered and carefully protected with adhesive tape. Due to loss of "A" battery current, it is inadvisable to make total length of cable more than 20 feet.

All excess cable should be coiled up *at the battery end of the installation*, that is, away from the Receiving Set. In coiling the cable near storage batteries, care should be taken that it is not laid, or does not pass over the top of storage batteries, otherwise the cable or wire covering is apt to be eaten away by the acid fumes.

**CONNECTING BATTERY CABLE TO BATTERIES.** On this page and the pages following are wiring diagrams showing the proper connections of the cable leading from the receiving set to the batteries. *Follow the diagram carefully in making your battery connections.*

Sec. 8.

Be sure that all storage battery binding posts are bright and clean and that nuts are screwed down tightly, using pliers if necessary. If the storage battery does not have binding posts it is suggested that two lead-coated battery "pinch clips" be purchased and soldered to the ends of the battery cable red and black wires.

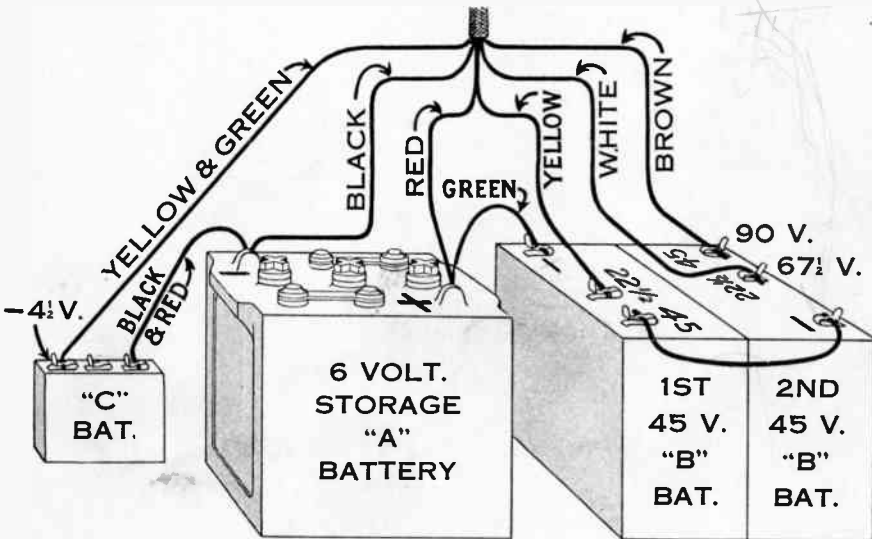

Illustration 25

**WIRING DIAGRAMS FOR MODELS 30, 32, 35 AND 20 COMPACT**

See Illustration 26 if Fuse Block is used;  
and Illustration 27 if Battery Charger is used.

Sec. 9. **BATTERY CABLE FUSE BLOCK.** The battery cable fuse block is recommended for the same reason that fuses are installed in all house electric light and power circuits which are to be approved by the Fire Underwriters.

The fuse block should be fixed firmly to a rigid support and as near to battery terminals as it is conveniently possible to locate it. The wires leading from the fuse block to the battery terminals should be stiff and heavily insulated. No. 14 rubber covered (electric light) wire is recommended.

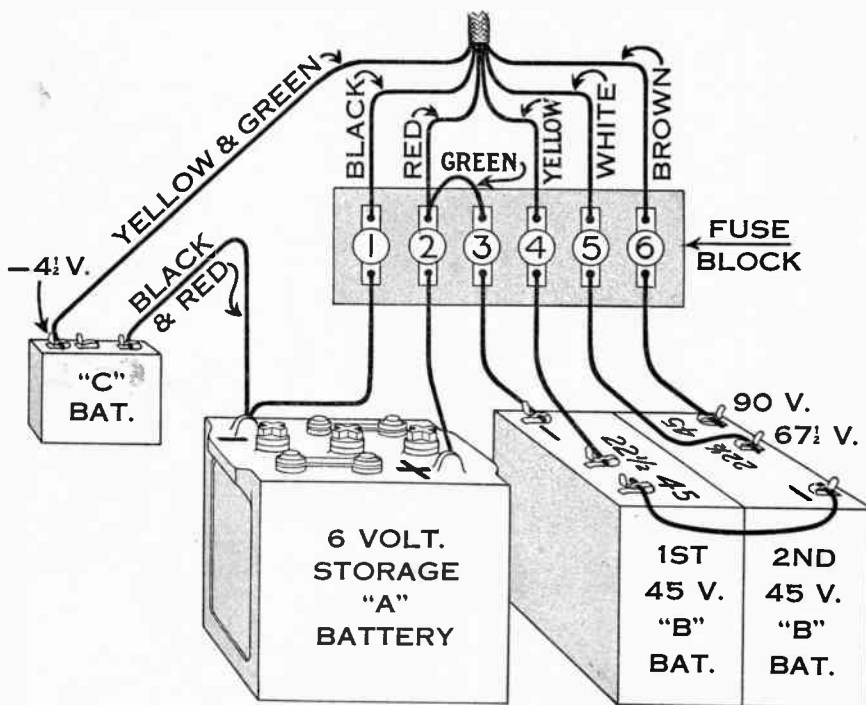

Illustration 26

SHOWING RELATIVE POSITIONS OF FUSE BLOCK, BATTERY CABLE WIRES AND BATTERIES.

Fuses 1 and 2, each 2-ampere capacity. Fuses 3, 4, 5 and 6 should be 1-ampere capacity.



**CONNECTING STORAGE BATTERY TO BATTERY CHARGER.** Sec. 10.

It is recommended that a two-way switch be used as a means of connecting the storage battery to a battery charger. It is preferable to have the storage battery located at some distance from the charger and switch, as illustrated below.

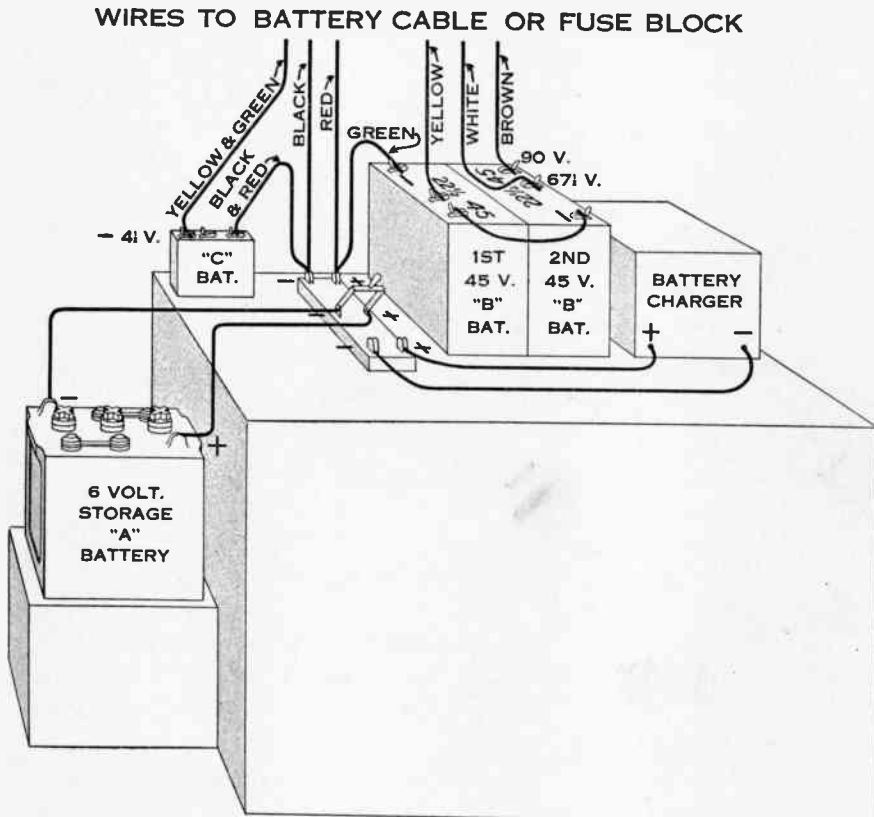

Illustration 27

**WIRING DIAGRAMS, SHOWING INSTALLATION OF TWO-WAY SWITCH AND BATTERY CHARGER**

See Illustration 26 for method of installing Fuse Block.

Sec. 11. SPECIAL INFORMATION FOR MAKING WIRING CONNECTIONS, ETC., TO THE MODEL 35.

The Model 35 differs from other Atwater Kent receivers in that the tubes and wiring connections, inside the set, are reached through an opening in the bottom of the set instead of the top.

The first thing to do after placing the Model 35 in a desired spot is to lift it up and turn it over, so that it rests on its top with the "Station Dial" and "Volume Control" pointing towards the back and away from you. (See illustration opposite.)

**CONNECTION OF SPEAKER CABLE, ANTENNA LEAD-IN AND GROUND WIRES:** This is done by passing the terminals of the speaker cable through the hole in the cabinet marked "Radio Speaker." (See illustration on opposite page.) By pressing down on the top of the binding post, opposite the designation "Red Tracer Lead," a small hole will be opened in the side of the binding post. Insert the end of the **red and black wire** in this hole and remove the pressure from the top of the post. It will spring up and lock the end of the wire securely in place. Now follow the same method in connecting the "black lead" to its binding post. See illustrations on page 19.

Next, scrape off about  $\frac{1}{4}$  inch of insulation from the end of the "antenna lead-in wire" and insert it in the hole in its binding post and then do the same with the "ground wire." For location of these binding posts see page opposite.

Keep the set in its upside down position until all the tubes have been inserted and tested—for method to be followed see pages 29 and 30.

When all tubes are in their place and burning properly, **and before you have turned the set right side up**, reach over and turn the "Station Dial" slowly to right and left. If there are any broadcasting stations on the air and within range, you should hear them. If you do, your set is working properly and can now be turned right side up. **Do this by lifting** and turning the front (dial side), up **and towards you**. If your tubes have been properly inserted in their sockets, there will be no danger of their slipping out as the sockets are made to hold tubes firmly in place and upside down.

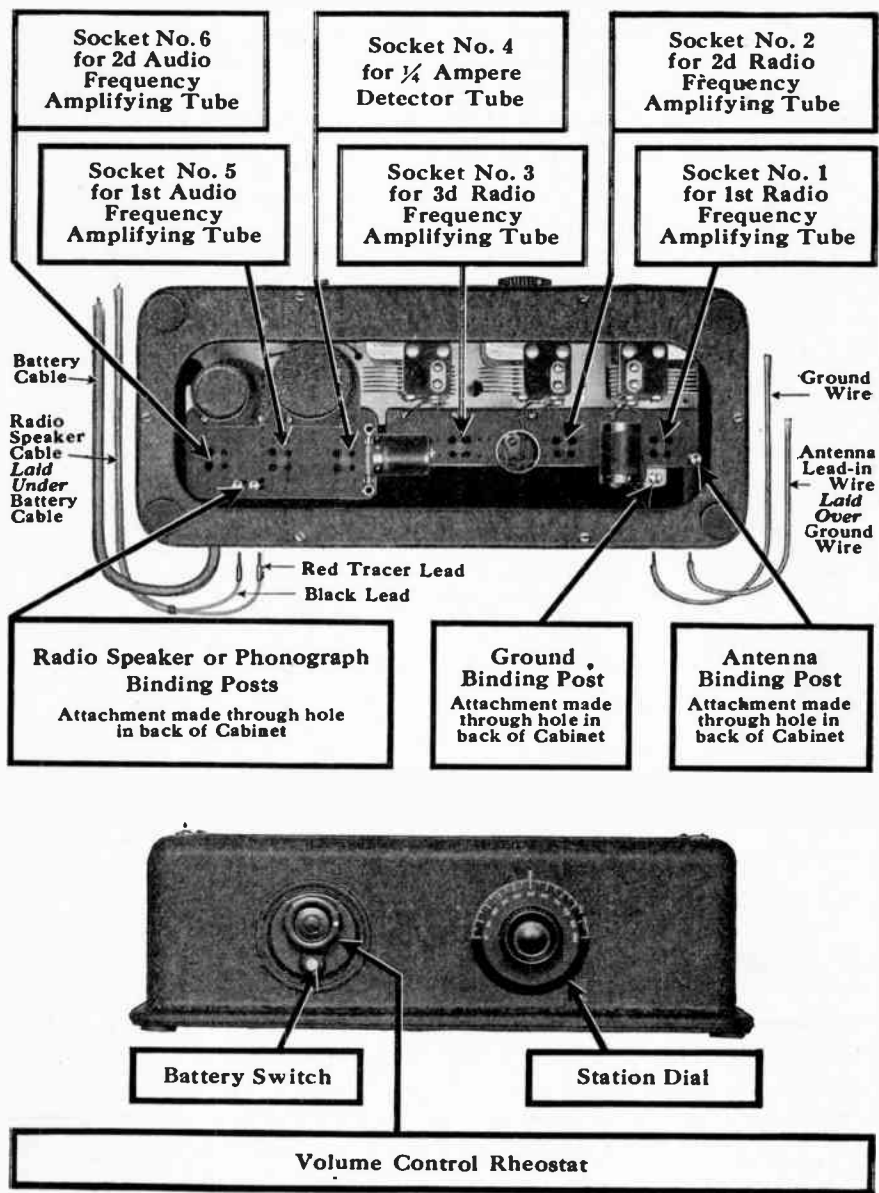

Illustration 28  
LOCATION OF CONTROLS, ETC., MODEL 35

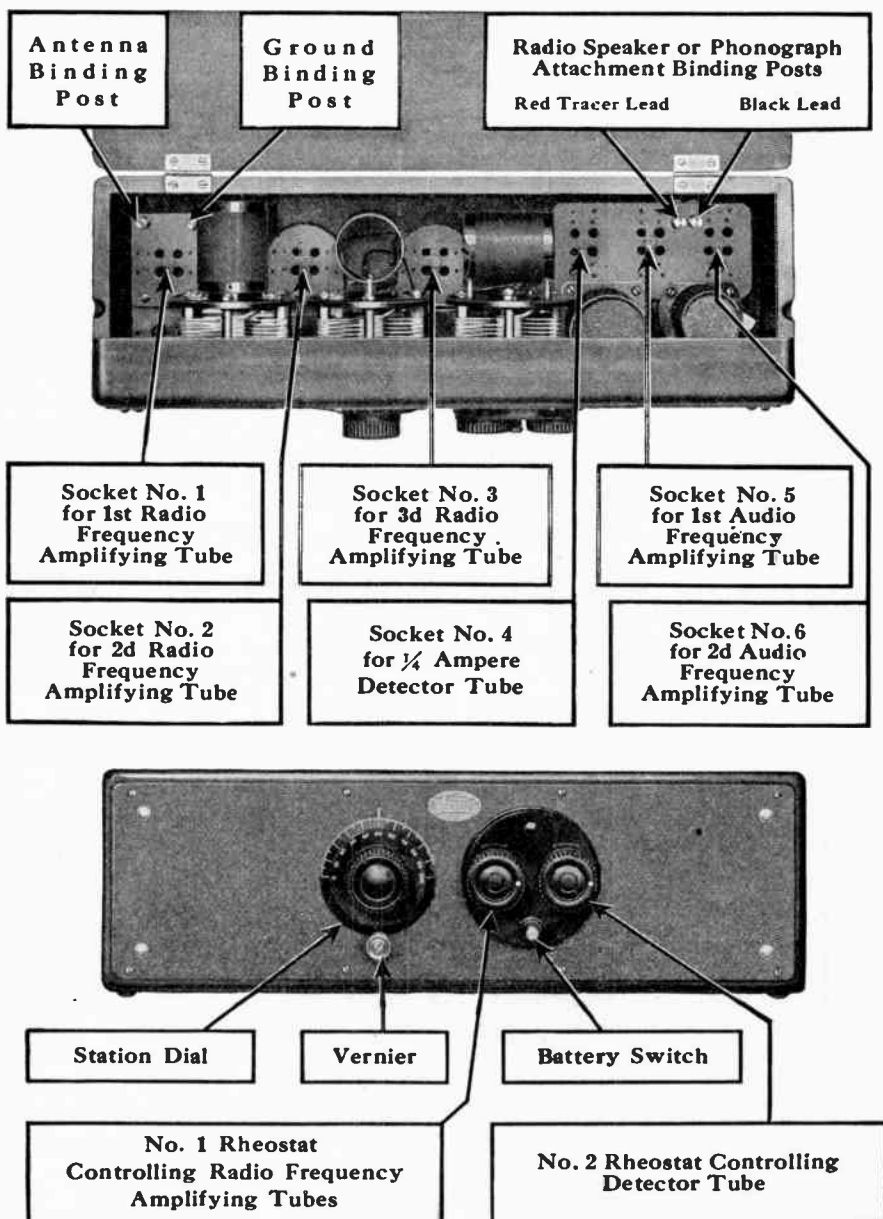

Illustration 29  
 LOCATION OF CONTROLS, ETC., FOR MODEL 30

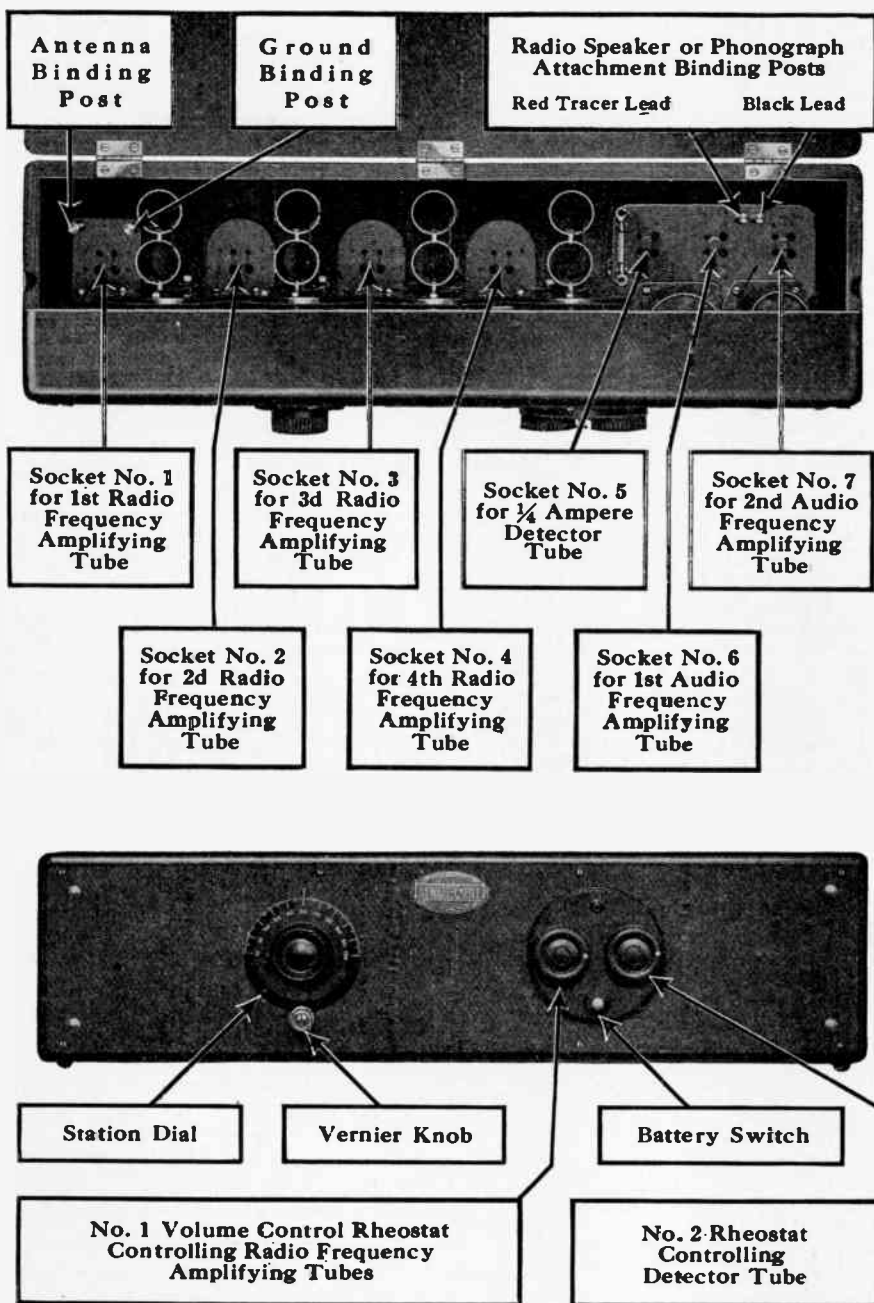

Illustration 30

LOCATION OF CONTROLS, ETC., MODEL 32

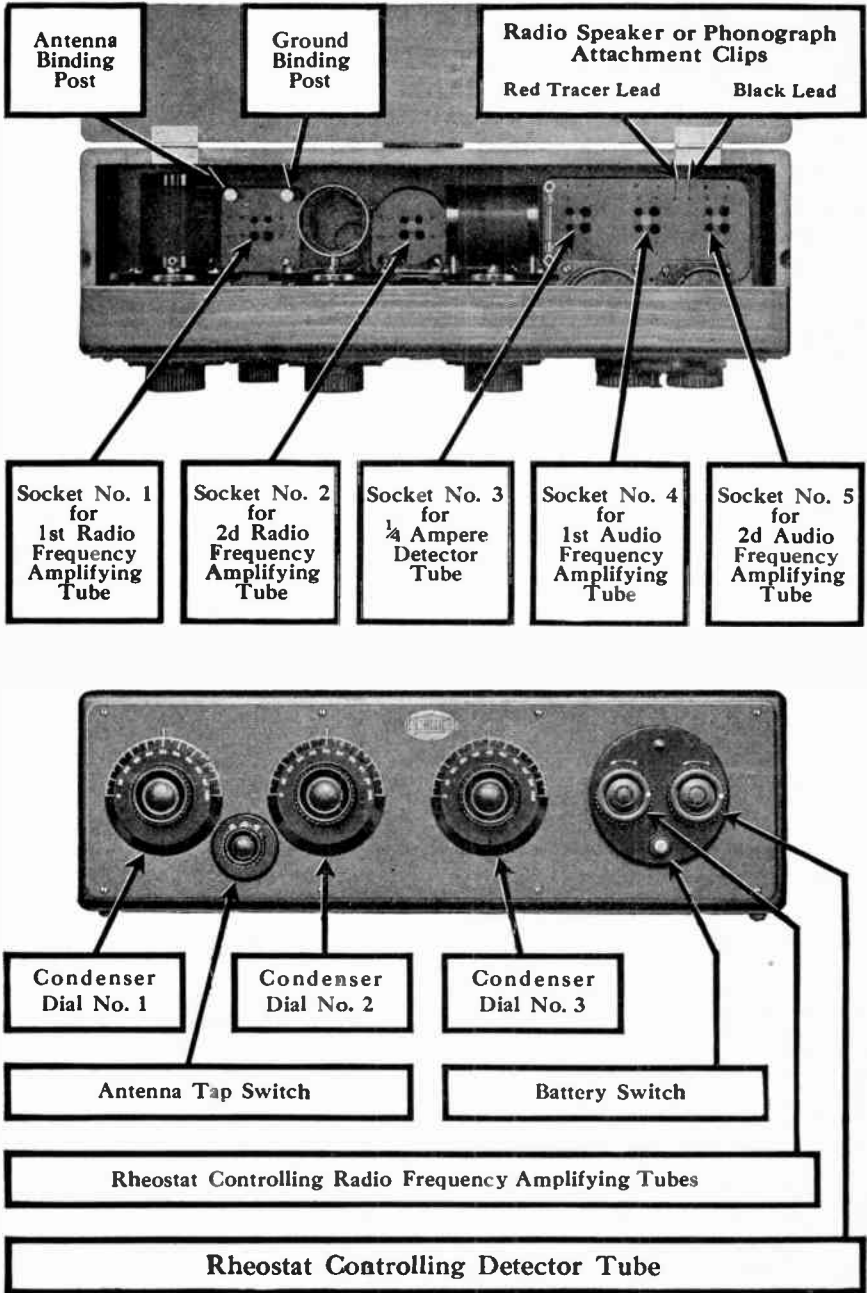

Illustration 31

LOCATION OF CONTROLS, ETC., MODEL 20 COMPACT

**CAUTION:** *Be sure and check most carefully all battery connections before proceeding further.*

**INSERTING TUBES AND TESTING.** (Refer to illustrations on Sec. 12. pages 25 to 28 incl.) After all battery connections have been made and checked, insert *one* tube (see Secs. 13 and 14), in any one of the tube sockets and pull *out* the battery switch. Now turn *both* rheostat knobs to the right (clockwise). About three-quarters of their total turning distance should be sufficient. The Model 35 has but *one* rheostat. When lighted, the tube should glow but faintly with a dull golden color, sometimes difficult to see in the day time.

If the tube does *not* light up, *again check all battery connections*, as it is possible that you have attached an "A" battery connection to a "B" battery binding post, thus allowing considerably more than 5 volts to be applied to the tube filament, and have burned out the tube. If the battery connections are *absolutely correct*, try another tube in the socket, as tubes are sometimes found to be imperfect after purchase.

By inserting one tube and testing, as outlined above, you will be safeguarded against the possibility of burning out all your tubes in case you have made a mistake in your wiring connections.

If the first tube you insert *burns properly*, you can now proceed to insert the rest of the tubes in the remaining sockets.

These tubes each have two thick and two thin prongs, which must be fitted into the large and small holes which form the tube sockets in the receiving set.

**INSERTING TUBES IN MODELS 32, 30 AND 20 COMPACT.** Sec. 13. Facing the front or dial side of the set, insert tubes in the Radio Frequency sockets, by turning the tubes so that the little brass pins (protruding from the sides of their bases) point to the **BACK** of the set. To insert tubes in the Detector Tube and Audio Amplification sockets, turn the tubes so that pins point towards the **LEFT** side of receiving set. See illustrations 32 and 33 on the following page.

When prongs are in their proper holes, press down on tube until base rests firmly on socket plate.

### INSERTION OF TUBES IN MODELS 32, 30 AND 20 COMPACT.

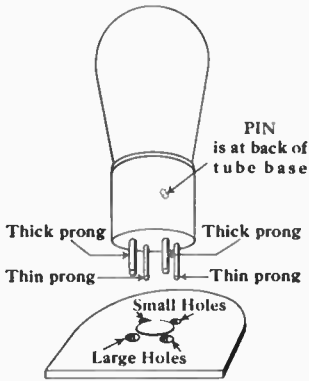

Illustration 32  
Radio Frequency Sockets

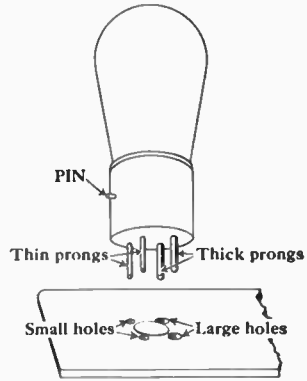

Illustration 33  
Detector and Amplifying Sockets

Sec. 14. **INSERTING TUBES IN MODEL 35.** Facing the back of the set, while it is upside down, insert tubes in sockets 1, 2 and 3 by turning the tubes so that the little brass pins (protruding from the sides of their bases) point to the **BACK** of the set that is towards you. To insert tubes in sockets 4, 5 and 6, turn the tubes so that pins point towards the **RIGHT** end of receiving set. When prongs are in their proper holes, press down on tube until base rests firmly on socket plate.

### INSERTION OF TUBES IN MODEL 35

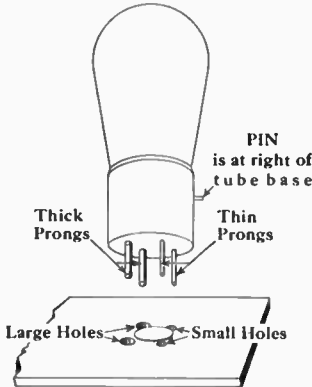

Illustration 34  
Sockets 4, 5 and 6

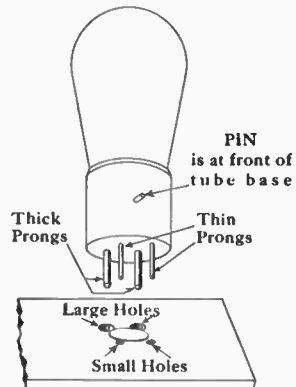

Illustration 35  
Sockets 1, 2 and 3

Sec. 15. **ADJUSTING THE ANTENNA TAP SWITCH.** (Model 20 Compact, only.) Turn the switch so that the contact spring rests on tap 2, the center tap. For further information see **PART III, Section 10.**



**SUMMARY.** If you have followed instructions carefully, you now have your **RECEIVING SET** properly connected to the **ANTENNA** and **GROUND**, the **SPEAKER** or **PHONOGRAPH ATTACHMENT** and the **BATTERIES**. Your **TUBES** are all in their sockets and **BURNING PROPERLY**, because the **BATTERY SWITCH** is pulled **OUT** and **THE RHEOSTATS** are turned about **THREE QUARTERS** to the **RIGHT** (clockwise).

You are now ready to **RECEIVE BROADCASTING**.

## Part II. OPERATION

---



Illustration 36

**ONE DIAL RECEIVING SETS.** Stations may be brought in with Sec. 1. the utmost ease by merely turning the Station Dial to the right or left between 0 and 100. After a signal has been heard, a finer adjustment of the Station Dial will bring in maximum volume. The vernier is for very fine adjustment. To use it, simply press it in and turn.

Volume—that is, loudness—may be regulated by adjusting the Volume Control Rheostat. For less volume, turn the rheostat to the left—counter clockwise. For more volume, turn to right—clockwise. Do not be alarmed if the rheostat becomes hot after continued operation of the set.

Rheostats do **not** completely shut off the current, although usually no signal can be heard when they are turned all the way to the left, therefore—**Be sure to push in the battery switch when you are through operating the set.**

Sec. 2. **SELECTING STATIONS:** Due to the difference in “day and night range” (see PART V, Section 1 for further information), the best results in radio reception will be obtained after night fall. In fact, your first attempt to bring in a station may not be successful because you make this attempt in the day time when no nearby station is broadcasting. If you will refer to your newspaper, you can readily find out at what hour the various stations will be “on the air.”

Your newspaper will also give the stations’ **WAVE LENGTH** in meters. By referring to the following diagrams you can tell where a station should “come in” on your Station Dial.

As an example, a station sending on 360 meters should be heard by turning the Station Dial (Model 30 or 32), around to approximately 39, and one broadcasting on 496 meters should be received at a point correspondingly higher, or approximately 77. (See illustration 37).

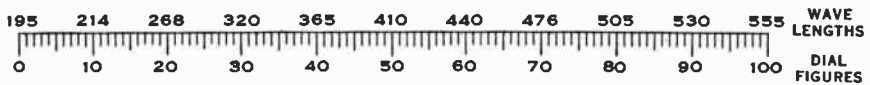

Wave Length Diagram for Models 30 and 32

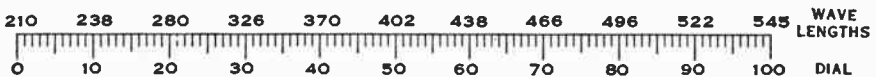

Wave Length Diagram for Model 35

Sec. 3. **LOGGING THE DIAL:** The dial setting of any station heard may be written down on the Log Card, supplied with the set. Any stations so listed can be instantly returned to by again turning the Station Dial to the setting written in the Log, *provided of course, that the station is broadcasting and within range.*

**THREE DIAL RECEIVERS.** Due to the difference in “day and night range” (see PART V, Section 1 for further information), the best results in radio reception will be obtained after night fall, although even a beginner should experience no difficulty in tuning in a “local broadcasting station” (one that is located within a few miles radius) in daylight hours. Sec. 4.

In order to select the broadcasting stations nearest to you, refer to your local newspaper and see what stations are broadcasting at the particular time you are ready to start tuning. Your paper should not only give you the nearest stations broadcasting, but also their respective WAVE-LENGTHS.

Table on page 35 gives the Wave Lengths of a number of well known broadcasting stations with the DIAL SETTINGS that brought in their broadcasting, using the Model 20 Compact. Refer to the table, *and pick out from it the Wave Length most nearly corresponding to the Wave Length of the station you wish to try to tune in.* Now turn the dials of your receiving set so that the numbers (or divisions) engraved on their outer rims, corresponding to the numbers given in the table, *come directly under the little white line engraved on the receiving set,* as shown in illustration 37.



Illustration 37

As your particular receiving set may vary slightly from the one used to secure the dial settings given in the table, or if you are endeavoring to tune in a station with a slightly *longer* or *shorter* wave length than any given in the column headed "WAVE LENGTH," your first setting of the dials may not bring the desired results. In this case the dial to the right (dial No. 3) should be turned a *division* or so to the *right*. Then dial No. 2 should be turned a *division* or so to the *right* and dial No. 1 should be revolved *slowly several divisions to right and left of the number given in the table*.

If no results are obtained continue the operation outlined above by turning dial No. 2 a division or so *to the right*, then dial No. 3 a division or so *to the right*, and revolve dial No. 1 *to right and left several divisions*. Continue this operation until all the dials have been turned so that they are five or six divisions to the right of the numbers given in the table.

If, after turning the dials to the right as outlined above, you do not hear signals, *return your dials to the original setting* (the numbers given in the table) and proceed to follow the instructions given in the above paragraphs, only *this time turn the dials to the left*.

When voices or music are once heard, the dials should *each be very slowly* turned to right and left, until maximum volume and clearness are obtained.

Experience will soon show you whether *your* settings should be lower or higher than those given in the accompanying table. The reason that you are instructed to turn dial No. 1 *several divisions to right and left* instead of but a division or so in one direction, is that your setting for dial No. 1 will practically never correspond to the setting given in our table, as the setting of your dial No. 1 depends on the size of the antenna you have installed.

Do not be discouraged if your first attempts at tuning bring more or less disappointing results; practice makes perfect, and in a very short time you should be able to tune in practically any desired station with rapidity and sureness.

Sec. 5. **VOLUME CONTROL.** For less volume—that is, loudness—turn the volume control rheostat to the left—counter clockwise. For more volume—turn the rheostat to the right—clockwise.

**Note**—Be sure to push in the battery switch when you are through operating the set.

**LOGGING THE DIALS.** When once a station has been tuned in, it can again be tuned in by turning the dials to the same setting, *provided, of course, that the same station is broadcasting and that atmospheric conditions are the same or better than when the station was originally tuned in.* Sec. 6.

### DIAL SETTINGS FOR MODEL 20 COMPACT

Sec. 7.

CITY	CALL LETTERS	WAVE LENGTH	DIAL SETTINGS				
			1			2	3
			Tap 1	Tap 2	Tap 3		
Hastings.....	KFKX	288.3		23		24	24
Atlantic City.....	WPG	299.8		25		26	26
Providence.....	WJAR	305.9		27		28	28
Pittsburgh.....	KDKA	309.1		28		29	29
Buffalo.....	WGR	319.0		30		31	31
Cincinnati.....	WSAI	325.9		31		32	32
Springfield.....	WBZ	333.1		32		33	33
Zion.....	WCBD	344.6		35		36	36
Detroit.....	WWJ	352.7		36		37	37
Schenectady.....	WGY	379.5		42		43	43
Philadelphia.....	WFI	394.5		46		47	47
Newark.....	WOR	405.2		48		49	49
Minn.- St. Paul.....	WCCO	416.4		51		52	52
Cincinnati.....	WLW	422.3		52		53	53
Atlanta.....	WSB	428.3		54		55	55
Jefferson City.....	WOS	440.9		58		59	59
Chicago.....	WMAQ	447.5		60		61	61
New York.....	WJZ	454.3		62		63	63
Pittsburgh.....	WCAE	461.3		64		65	65
Los Angeles.....	KFI	469.0		66		67	67
Boston.....	WEEI	475.9		68		69	69
Davenport.....	WOC	483.6		71		72	72
New York.....	WEAF	491.5		74		75	75
Philadelphia.....	WOO	508.2		79		80	80
Chicago.....	KYW	535.4		90		91	91
St. Louis.....	KSD	545.1		94		95	95

**IT IS RECOMMENDED** that as soon as you feel thoroughly familiar with the operation of your set that you read carefully PART III of this book, dealing with the improvement of reception.

## Part III.

# IMPROVING RECEPTION

---

**Sec. 1. DETERMINING WHICH OF YOUR TUBES ARE BEST SUITED FOR THE RADIO FREQUENCY AND DETECTOR TUBE SOCKETS.** It is quite usual to find that out of every set of tubes bought for your receiving set, certain of them will give better results when used in certain sockets than when used in any of the other sockets. Hence it is a good plan to take steps to determine which tubes are best suited for these particular sockets.

The test should be made as follows: Tune in a rather distant station, one that does not come in with any great volume. Turn the Volume Control Rheostat all the way on. With all tubes burning, *interchange* tubes from sockets 1 and 2 (see pages 25 to 28 for location of sockets). Note carefully any betterment in reception, then replace the tubes in their original sockets and try the same experiment by interchanging the tubes from sockets 1 and 3. Then interchange 1 and 4. If yours is a six or seven tube set, proceed with the experiment until you have tried out all the tubes you have.

It may be necessary to try the same experiment with certain tubes over again several times before you can be sure which one brings in the very best results, when placed in socket No. 1.

When you finally determine which tube is best for Socket No. 1, *leave it there* and proceed to try the same test with the remaining tubes, by placing them alternately in Socket No. 2. If yours is a *five* tube set, proceed with the test *by placing the remaining tubes alternately in Socket No. 3*, the Detector Tube Socket. If it is a six tube set, proceed trying the remaining tubes in sockets 3 and 4. If it is a seven tube set, proceed trying out the remaining tubes in sockets 3, 4 and 5.

The remaining tubes will doubtless prove satisfactory when placed in the last two sockets—the Audio Amplification Tube Sockets, *however*, if any of your tubes were found to give very weak signals when tested in the Radio Frequency Amplification and Detector Tube Socket, *they should be immediately returned to your dealer to be tested*, so that they may be returned to the manufacturer, if found defective.

**Note:—**If you are using a special detector tube, or a special power tube in the last audio amplification socket, do not include these tubes in the above test.

**ALTERING THE LENGTH OR HEIGHT OF AN OUTSIDE AN- Sec. 2.**  
**TENNA.** If, after you have made the tests and experiments with your Tubes, you still feel that you are not getting the best possible results in the way of reception, you might find it advantageous to study over your present antenna installation with the idea of bettering it.

The two things that your antenna has most to do with, are volume and selectivity. If you think you should be getting more volume, you might experiment with ways and means of lengthening your antenna, *preferably in a straight line.* If this is impossible and your antenna is very short, that is, under 50 feet in length, you might try placing two or more wires in parallel. This applies to an outside antenna, only. Details showing how the wires should be spaced and attached to the "spreaders," etc., are shown in illustration 38. *It should be noted, however, that doubling the number of wires does not double the effectiveness of the antenna.* As an example, two wires each forty feet long, stretched parallel to each other are not twice as effective as one forty foot wire, nor are they equal to a single wire 80 feet long in a straight line.

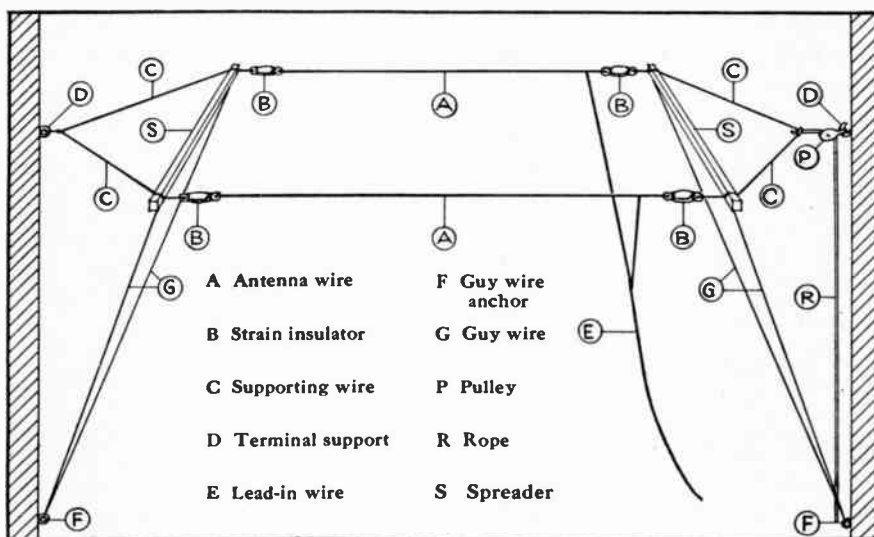

Illustration 38

Note: The minimum width of the "Spreaders" should not be less than 2 ft. 6 in. and 3 ft. or more if possible.

If you have ample volume, but lack selectivity, it may be that your antenna is *too long*. In this case the remedy should be easy to apply—simply shorten your antenna by cutting off a piece from the end furthest from the lead-in, as illustrated below.

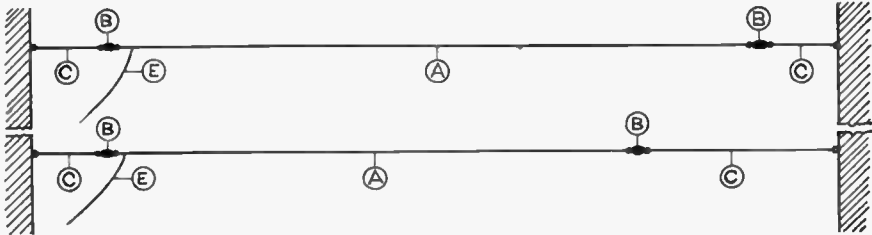

Illustration 39

Showing how an Antenna can be shortened without changing its terminal supports.

Another method of increasing volume is to *raise your antenna higher above the ground*. And by "ground" we do not mean simply the earth, but any surface that may act as a ground, such as a roof, tree, chimney or the like. Speaking generally, an antenna cannot be raised too high, unless by so doing the lead-in wire is increased in length to such an extent as to make the combined length of antenna and lead-in so great as to affect selectivity.

Sec. 3. **IMPROVING INSIDE ANTENNAS.** If you have an inside antenna and seem to lack volume, try a series of experiments by running a wire in other places than you now have it. For instance—if your antenna now runs around the picture mould, try one under a rug, as your room may be surrounded with steel girders or metal lath. Or, better still, try a **short outside antenna**, hung from the roof to your window, or from your window to a point ten or fifteen feet above the ground (see illustration, Page 8).

Sec. 4. **USING A SPECIAL DETECTOR TUBE.** Increased volume can often be secured by the use of a  $\frac{1}{4}$  ampere detector tube. This is most often true where it is necessary to use a **short inside antenna**.

Note particularly the amount of "B" battery voltage required for best results. This information will be found in the instruction sheet packed in the carton in which the tube is shipped.



**USING A SEPARATE "B" BATTERY FOR THE DETECTOR TUBE.** Often a slight whistling noise occurs after the "B" batteries have been used for some time, caused by the fact that the No. 1 battery supplies current to the Detector as well as the Amplifying Tubes, thus weakening the first "B" battery before the others are affected. When this whistling occurs the first "B" battery should be replaced. In order to guard against this possible trouble, some owners use a separate "B" battery to supply current to the Detector Tube, altering their wiring connections as follows: The "yellow" wire is run to the 22½ volt tap of the extra battery. The "green" wire is run to the minus tap of the extra battery and a special wire is run from the minus tap of the extra battery to the minus tap of the first of the regular "B" batteries.

**USING A POWER TUBE.** Increased volume and general improvement in reception may be obtained by placing a special power tube in the last audio amplification socket.

The use of this type of tube requires the use of additional "B" and "C" battery voltage. For the exact voltages, see the instructions packed in each power tube carton.

The addition of one or more "B" and "C" batteries can be readily made, as indicated in the diagram shown in illustration 40.

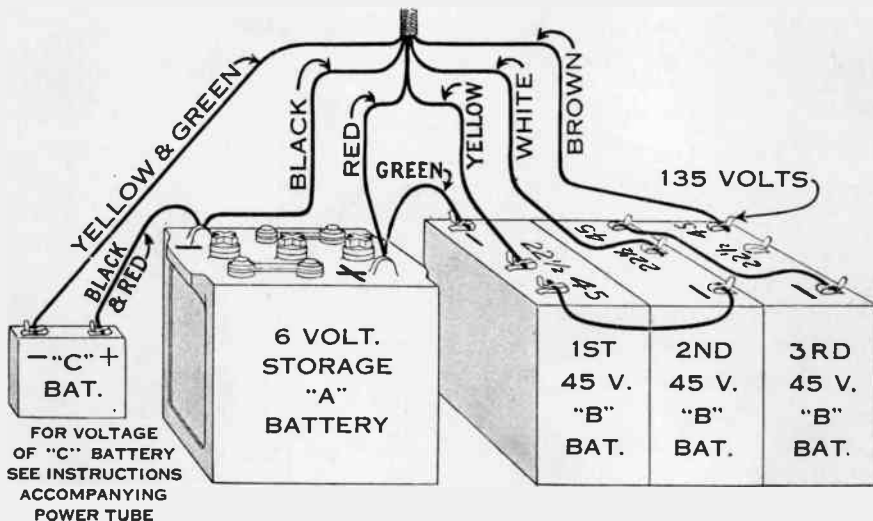

Illustration 40

WIRING DIAGRAM FOR MODELS 30, 32, 35 AND 20 COMPACT  
USING A POWER TUBE IN THE LAST AUDIO SOCKET

Sec. 7. **CHANGING THE LOCATION OF THE SPEAKER OR PHONOGRAPH ATTACHMENT.** While it is usually desirable to have the Radio Speaker located *close to the Receiving Set*, so that it is easily heard when tuning in a distant station, it is sometimes found advantageous to move it to another part of the room so that the natural acoustical properties of the room can be used to maximum advantage.

Sec. 8. **USING ONE OR MORE RADIO SPEAKERS IN ADDITION TO THE ORIGINAL SPEAKER OR PHONOGRAPH ATTACHMENT.** If your receiving set is located in an unusually large room and you wish to entertain a goodly number of people, either seated or dancing, it is recommended that you try the effect of using one or two Radio Speakers *in addition* to your original Speaker or Phonograph Attachment. They should be placed in widely separated parts of the room and should be wired in parallel—that is, all red tracer wires should go to one binding post on the receiving set and all black wires to the other.

Additional Speakers may also be placed in other rooms in your house, such as your bedroom, nursery, or servants' quarters. Any reasonable number of Speakers may be used at the same time.

While the use of more than one Speaker slightly decreases the volume of sound heard from each Speaker, but the volume of sound, in all parts of the room, is of practically the same intensity.

Sec. 9. **ADJUSTING ATWATER KENT SPEAKERS OR PHONOGRAPH ATTACHMENTS.** The adjustment mechanism is not to be considered as an aid to better tuning, to be constantly changed. All Speakers and Phonograph Attachments are tested for volume and tonal quality, and *are adjusted by experts*, before leaving our factory. Under ordinary conditions, and when used with Atwater Kent Receiving Sets, the factory adjustment should prove entirely satisfactory.

If, however, the adjustment has been tampered with or is not just as it should be, due to some other cause, it is very easily readjusted. Simply tip back the Speaker on its base, while a powerful station is tuned in, and turn the knurled cap (located in its base) to right or left until maximum volume and clearness are obtained. Usually, it is best to start

by turning to the right (clockwise) until the music or voices suddenly become muffled, often accompanied by a rattle and general loss in volume. Then, *very slowly and carefully* turn the knurled cap to the left (counter clockwise) until the voices or music suddenly come out clear, loud and free from rattle. STOP ADJUSTMENT AT THIS POINT—to turn further only reduces the clarity and volume of tone. The Phonograph Attachment is adjusted in the same manner.

**CHANGING THE ANTENNA TAP SWITCH. MODEL 20 COMPACT, ONLY.** In PART I, under the heading "LOCATING AND ERECTING THE ANTENNA," we explained to you how too *short* an antenna will not collect enough electrical energy to enable you to tune in distant broadcasts, and how too *long* an antenna will collect so much electrical energy from nearby stations that you will be unable to tune them out—that is, your set will not be "selective." The Antenna Tap Switch is for the purpose of overcoming these difficulties. When placed on Tap 1 it has the effect of *shortening* your antenna, thereby *increasing the selectivity* of your set. When placed on Tap 3 it has the effect of *lengthening* your antenna, thereby *increasing volume*. It was because of this difference in the results obtained, when the first and third taps are used, that we directed you to use Tap 2 when you made your first attempt to tune your set. Sec. 10.

If the combined length of your antenna and lead-in are unusually *long*, you will no doubt secure best results by using Tap 1 or Tap 2. If the combined length of your antenna and lead-in is comparatively *short*, best results should be secured with Tap 2 or Tap 3. But do not hesitate to change your antenna taps, even during reception of broadcasting, in order to secure maximum selectivity and volume.

When tuning in stations whose dial readings on the 2nd and 3rd dial lie between 0 and 20 on the dials, best results will be obtained by using the 1st or 2nd antenna tap.

**NOTE:** Changing the antenna taps will change the readings of dial No. 1, that is, Tap 1 will give higher readings, while Tap 3 will give lower readings than those given in the Dial Setting Tables.

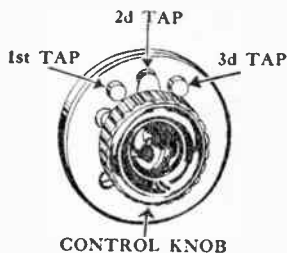

Illustration 41  
ANTENNA TAP SWITCH  
MODEL 20 COMPACT

## Part IV. MAINTENANCE

---

Proper care of your batteries will go further towards assuring continued and successful operation of your receiving set than any other thing you can do. Many times when poor reception is blamed on the receiving set, the fault lies with the operator, who has neglected to keep storage batteries charged or has allowed dry batteries to run down until they are practically worthless.

- Sec. 1. **CARE OF STORAGE BATTERIES.** All first-class manufacturers of storage batteries supply their customers with full information as to the proper care and maintenance of their batteries. *Be sure to get their printed instructions and read them through carefully.*

*CAUTION: Never use a lighted match, candle or other flame to see if the battery needs to be filled with water, as the fumes of the acid inside are explosive. If your battery is located in a dark room use a regular electric light or flash light, or disconnect the battery and carry it to the daylight or to a place where an electric light is located.*

- Sec. 2. **CHARGING STORAGE BATTERIES.** To possess your own battery charging apparatus is an advantage, but care should be exercised in its installation and use. Always disconnect *both* the wires (running from the battery to the receiving set) from the storage battery before connecting the battery charger wires to the storage battery and starting the charger.

A better method is to use a two-way switch (see illustration 27, page 23) in which case all chance for accident is reduced to a minimum.

*In either case, always turn off the charger at the house current socket, before reconnecting the battery to receiving set.*

*The frequency with which it will be necessary for you to charge your battery will depend on the ampere hour capacity of the particular battery you possess, and the length of time you use your set between charges; to determine this a frequent check should be kept on charging by use of a "hydrometer" unless some other means is included with the battery. The use of a voltmeter is not recommended for checking the "A" battery as it does not give a true indication of the "A" battery's condition, but a battery should be charged at least once each month whether the receiving set has been used or not, so the deterioration in the battery will be prevented.*

*The length of time* your battery should be charged at any one time will depend upon its capacity (in ampere hours) and the rate with which your charger charges, but always check by use of a hydrometer unless some other means is included with your particular battery.

Due to the fact that corrosive fumes are given off from storage battery when it is being charged by a high rate charger, it is recommended that it be removed from any cabinet or other piece of fine furniture while being charged, unless special provision has been made for the escape of the gases generated in the battery during charging. This is not necessary when a "trickle charger" (low rate charger) is used.

It is advisable to allow an hour's time to intervene between the time that you stop charging your battery and the time you begin to use your set, if a high rate charger is used, otherwise you may be bothered with a crackling noise during reception. This will not be the case if a trickle charger is used.

**CARE OF DRY "B" BATTERIES.** Run down "B" batteries are one of the most frequent causes of poor reception. *In order to guard against this trouble we recommend that you purchase a high-grade "voltmeter" and test the voltage of your "B" batteries at frequent intervals.* A 45-volt "B" battery is practically useless when it registers *less than 34 volts.* A 22½-volt battery when it registers *less than 17 volts.* As one "dead" cell or battery will stop the flow of current through all the rest, it must be removed and replaced with a new one to secure satisfactory results. Sec. 3.

"C" Batteries should last several months, but their voltage should be checked occasionally, and if it is found to be as low as 3 volts, it should be replaced with a new one.

**TUBES.** As all tubes deteriorate in time, it is suggested that at least once a year all tubes be taken to your dealer for testing, or borrow an extra tube (one known to be perfect) and try it out in each socket in turn, thus comparing each of your old tubes with it. Sec. 4.

**WIRING CONNECTIONS.** Due to jarring and vibration, wiring connections are sometimes loosened, and it is recommended that at least once a month all connections, made to either "A" or "B" batteries by means of screw binding posts, be gone over and tightened up. Sec. 5.

## Part V.

### Some Causes of Poor Reception

---

- Sec. 1. **DAY AND NIGHT RANGE.** Reception of broadcasting is always very much better after night fall. It is considered good reception conditions when a standard five tube set will bring in satisfactory broadcasting from stations located not more than 200, or even 100 miles away, *in the day time*. Whereas, under the same conditions the same set will bring in with volume and clearness, *at night*, stations located more than 1000 miles distant.
- Sec. 2. **ATMOSPHERIC CONDITIONS.** One of the most usual causes of poor reception is due to atmospheric conditions. If you suddenly experience trouble in bringing in more or less distant stations, and your tubes are comparatively new and your batteries seem all right when tested, call up one or more neighbors and find out if they are experiencing the same difficulty—if they are, you can feel pretty sure that your trouble is not due to any part of your radio installation. However, if your neighbors are *not* experiencing the difficulty that you are encountering, you had better go over your complete installation in order to locate the possible cause of the trouble. Some of these possible causes are as follows:
- Sec. 3. **LOOSE OR CORRODED WIRING CONNECTIONS.** Try tightening all knurled nuts and examine all connections to see that they are bright and clean.
- Sec. 4. **DEFECTIVE LIGHTNING ARRESTER.** Test for this trouble by disconnecting the wire leading from the arrester to its ground, and see if it makes any difference in reception—if it does, put in a new lightning arrester.
- Sec. 5. **DEFECTIVE OR WORN OUT TUBES.** See PART IV., Sec. 4.
- Sec. 6. **ANTENNA GROUNDED OR BROKEN DOWN.** Examine your antenna and make sure it is not broken down, or that it has not sagged down on, or near some object that is grounding it. Or it may be that other wires, branches of a tree or the like, have sagged down or been blown across your antenna. Follow this examination of your antenna by a study of your lead-in, from where it is attached to the antenna to where it is attached to the receiving set. See PART I. Chapt. 2. Sec. 4.
- Sec. 7. **CABLE FROM RECEIVING SET TO BATTERIES IMPROPERLY PLACED.** See PART I, Chapt. 3, Sec. 7.

**FUSE BURNT OUT.** If you have installed a series of fuses (as Sec. 8. recommended in Part I, Chapt. 3, Sec. 9) it may be that one or more of these fuses has been burned out, due to a short circuit in the wires running between the fuse block and the Receiving Set, or in the wiring of the set itself. Or one of your tubes may be defective.

Examination of your fuses will quickly tell whether any of them have been burned out. If this be the case, *do not replace it with a new one until you have located the trouble and have had it corrected.*

**"FADING."** The "fading" of signals, which means that the voices or Sec. 9. music first come in distinctly, then fade away only to come in strongly after a short period of time, can hardly be classed as poor reception, for, as a rule this condition will be found to exist with only one or two stations on a given evening, while broadcasting will be heard from other and equally distant stations, without intermission or fading of any kind. Fading is attributed to atmospheric conditions that are more or less localized and therefore do not affect all broadcasting reception on any given night.

## Part VI.

### Some Causes of Disturbing Noises

---

Noises that disturb the pleasure of Radio Reception can be divided roughly into two classes: noises generated in some part of your Radio Installation—usually easily remedied, and noises due to conditions outside of your Radio Installation—often difficult or impossible to remedy.

To find out whether the disturbing noise is generated *inside* of your Radio Installation, tune in a station and then disconnect the antenna lead-in and ground wires from the receiving set. *If the noise continues*, it is no doubt due to something *inside* of your installation—most likely your batteries. Look to your "A" battery terminals to be sure they are not corroded, but are bright and clean. Next, test your "B" batteries and note whether all cells register the required voltage. See PART IV, Sec. 3.

A **CRACKLING, SIZZLING NOISE** is usually due to run down "B" batteries, and can be remedied by replacing the exhausted batteries with new ones.

A SLIGHT WHISTLING NOISE is often due to the fact that the No. 1 "B" battery, which supplies the Detector, as well as the Amplifying Tubes, is run down or exhausted, even though the rest of the batteries (or cells) are in excellent condition. By replacing the first "B" battery with a new one this trouble should disappear. See PART III, Sec. 5.

A CONTINUED SINGING NOISE. Heard while the set is connected to the antenna and ground. Sometimes due to the fact that the Radio Speaker is placed too close to the Receiving Set—try moving it further away from the set and see if the noise stops.

A WHISTLE WHICH VARIES AS YOU TURN THE DIAL. Due to a broken or poor ground Connection. Remove ground from cold water pipe, clean contact and replace.

If you are using a radiator or any other ground than a cold water pipe—try running a temporary ground to a cold water pipe and see if it overcomes the difficulty.

**OTHER NOISES, DUE TO CONDITIONS OUTSIDE OF  
YOUR RADIO INSTALLATION, ARE AS FOLLOWS:**

AN INTERMITTENT BUZZING. A strong, intermittent buzzing is usually caused by a commercial or governmental radio sending station.

AN INTERMITTENT "PEEPING" NOISE. An intermittent "peeping" noise, varying in intensity and sounding like the chirping of a little bird, is usually caused by an amateur sending station.

A CONSTANT, HIGH PITCHED WHISTLE. This is known as a "heterodyne whistle" and is due to the fact that another station is broadcasting on very nearly the same wave length as the station you have turned in. As a rule, it is best to give up attempting to tune in the station you are endeavoring to tune in, until the other station has signed off.

SCREECHING OR "BOB WHITE CALLS." These noises vary in intensity and are usually due to some other receiver that is being tuned in, in your immediate neighborhood. Nothing can be done to remedy this trouble—it is a case of "grin and bear it." *However, you should remember that your Atwater Kent Set does not radiate, hence it does not annoy others as your neighbor is annoying you.*

A CONSTANT CRACKLING, CLATTERING AND CRASHING. Usually due to static electricity generated in the upper atmosphere, which is picked up by your antenna wire and runs through your receiving set to the earth (ground). These noises are known as "static," and while a perfectly harmless phenomena, are at times exceedingly annoying. Nothing can be done to remedy them, but a change in the weather will entirely dispel them and reception will again be "as clear as a bell."



**A CONSTANT HUMMING.** Usually due to a dynamo located somewhere in your immediate neighborhood, or even at a distance, in which latter case the hum of the dynamo is transmitted through electric light or power wires, near which you have placed your antenna or lead-in. This is particularly apt to be the case if your antenna *parallels* electric light or power lines. By changing the location, or altering the direction of your antenna, you may be able to eliminate, or at least reduce this trouble.

**A CONTINUED OR INTERMITTENT BUBBLING.** Often due to a so-called "leak" in a nearby high powered electric transmission line and most apt to be noticed in wet weather.

**OTHER NOISES.** There are numerous other conditions that may cause annoying noises, such as certain types of Oil Burners, Electric Refrigerators, Washing Machines, etc., also X-Ray, Moving Picture or Violet Ray machines, located either in the same building that you are in or in your immediate neighborhood. Or near you may be an arc light, flashing electric sign, an electric welder or a similar electric device. Likewise, any piece of apparatus using an electric motor, such as a vacuum cleaner, electric elevator, air pump, vibrator, child's toy, etc., is apt to cause annoyance at various times.

Trolley lines passing within any reasonable distance of your set will be sure to affect it. Likewise, automobiles passing close by on the street, will at times, affect radio reception.

**CONCLUSION.** In concluding we would like to impress upon you that *almost invariably* you will find that poor reception, disturbing noises and other like troubles are *not* due to any defect in your Atwater Kent Receiving Set, Radio Speaker or Phonograph Attachment, provided they have not been tampered with since leaving our factory.

All parts used for the assembly of Receiving Sets are thoroughly tested, and the completed sets are carefully inspected and tested for actual receipt of signals. All Speakers are tested for tonal quality and volume, and are adjusted to give maximum results.

If you experience trouble of any kind in operating your set, *first* study over your installation, starting with your batteries, then the battery connections, tubes, antenna, lead-in and ground, before you decide that the trouble lies in the receiving set or radio speaker. If, after carefully examining and testing the various parts of the installation, as suggested in the various parts of this book, you are convinced that the receiving set or speaker is at fault, *do not attempt to locate and remedy the trouble yourself, but take the set or speaker to your dealer for examination by experts.*

# ATWATER KENT RADIO SPEAKERS

**T**HE apparatus which transforms the electrical impulses generated in the Receiving Set into audible sound, is called a Radio Speaker.

This wonderful piece of mechanism is a most important part of a radio installation, for it must be capable of *re-creating* the music, voices and other sounds exactly as they were broadcast, otherwise false notes, distorted voices and noisy vibrations will be the result

Only after months of scientific research and almost endless tests and experiments were Atwater Kent Radio Speakers and Phonograph Attachments offered to the public. As a result, their ability to re-create voices, music and other sounds is truly marvelous!

No Atwater Kent Receiving Set is complete without one, and the full beauty and clearness of your Receiver's reception of broadcasting will not be appreciated until you have heard it re-created by an Atwater Kent Radio Speaker.

Atwater Kent Radio Speakers and Phonograph Attachments are made complete in the Atwater Kent Factory and each Radio Speaker and Phonograph Attachment is thoroughly tested and adjusted to give best results before being packed for shipment.

If you have not already purchased an Atwater Kent Radio Speaker, it will pay you to secure one from your dealer and give it a thorough trial.

All Atwater Kent Radio Speakers are designed to take the volume and current of the new power tubes using 135 to 180 volts on the plate.

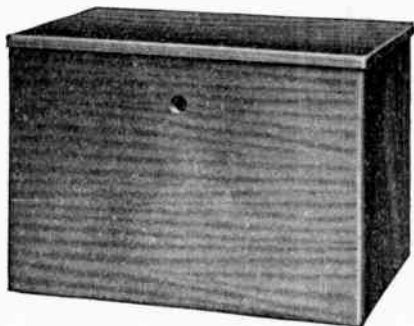

Illustration 42

## Battery Containers

These Containers are substantially made, and finished in a rich mahogany brown. The lids are not hinged, but are so constructed as to be quickly and easily removed, giving convenient access to all batteries, for testing, etc., without removing them from the container.



## Warranty

*All Atwater Kent Receiving Sets, Radio Speakers and Phonograph Attachments are warranted to be perfect when they leave our plant. A printed warrant and guarantee covering the terms on which we will replace or repair defective equipment accompanies each piece of Atwater Kent Apparatus.*