



# DX NEWS

*the magazine of the  
National Radio Club*

— SINCE 1933 —

VOLUME 51

ISSUE 20

FEBRUARY 27, 1984

NO MUSINGS column this week, no mail delivered monday, so....next week we will have another one of those double sized MUSE sections. Inside as a replacement, of sorts, is another super you-build-it article by Mark Connelly. (Keep those articles coming our way Mark. And the same goes to all the rest of you! - HQ)

APRIL FOOLS ISSUE material should be in our hands here no later than MARCH 24th. And PLEASE keep it clean and so forth, (stuff on FM and other spectrums will be fine as this is the issue almost everything goes!!) So, dig out those funny items and get them to us real soon, there isn't much time left!!

MEDIUMWAVE GUIDE, 5th edition, compiled by Robert Chester and presented by the Australian Radio DX Club. More info and facts on this book can be found on page 8 inside.

NRC NIGHT PATTERN BOOK UPDATER 34 Maps, each contain new stations not shown on the current maps, can be inserted as a change page or you can redraw them onto your original book pages. Maps are same scale as set presently used. Patterns are drawn sharp and are as accurate as can be found anywhere!! US\$3.50 this price includes shipping !!! Order from the Publication Center. And please allow 4 to 6 weeks for delivery.

From J.G. Herkimer, "For Sale: NRC 3 Foot Altazimuth loop, constructed by Steve Bohac, in brand new condition. (used once) \$165.00 Prefer local pickup. Reason for selling: I have two of them! James G. Herkimer, 3255 South Drive, Caledonia, NY 14423 (716) 538-4868 [Caledonia is 17 miles south of Rochester]"

Remaining Publishing Schedule for Volume 51:

| ISSUE | MASTHEAD DATE | PUB SESSION DATE | ISSUE | MASTHEAD DATE | PUB DATE  |
|-------|---------------|------------------|-------|---------------|-----------|
| 21    | MARCH 5       | FEBRUARY 26      | 26    | MAY 7         | APRIL 29  |
| 22    | MARCH 12      | MARCH 4          | 27    | JUNE 11       | JUNE 3    |
| 23    | MARCH 19      | MARCH 11         | 28    | JULY 16       | JULY 8    |
| 24    | APRIL 2       | MARCH 25         | 29    | AUGUST 20     | AUGUST 12 |
| 25    | APRIL 16      | APRIL 8          | 30    | SEPTEMBER 24  | SEPT 16   |

Oh yea, almost forgot. Hope you like the new type found on this page, we've noticed that you've noticed, thanks for the postcards. And yes, we will probably use this from now on (Dr. Gruis will be glad to hear this, hi- mike). Also word from the NRC Data Center, they say that all orders of the address label, those ordered by Feb 1st, are now in your hands. Also please check over your mailing label, found on the back page, make sure your name is correct and the address is proper with the right 'street' or 'drive' or whatever, if that part pertains that is. If you didn't get this issue then your address label is wrong, hi. Also, thanks for those sending in your votes for keeping mike in the lake, the extended peace and quiet is greatly appreciated around here. ("here-here", "yea", = [comments from HQ staff])

## CPC TESTS

NONE scheduled for the near future. And please, if possible, when scheduling a test with a station try to get as much lead time as possible, preferably a month in advance would be nice. Thanks.

## LOOK INSIDE:

NO Musings Column this week. Look for it next issue.

|                 |                            |                          |
|-----------------|----------------------------|--------------------------|
| 2.....AM Switch | 9.....Seven Passive Tuners | 20.....Verie Game Column |
| 3.....DDXD      | 18.....Stn Profile - CKNX  | 22.....Ramblin' Back     |
| 7.....IDX       | 19.....Contests update     | 23.....HAP Page          |

**THE WORLD'S OLDEST AND LARGEST ALL MEDIUM-WAVE DX CLUB**

# AM SWITCH

JERRY STARR  
C/O WSRD RADIO  
401 N. BLAINE AVENUE  
YOUNGSTOWN, OHIO 44505

### CALL LETTER CHANGES

| Old call:               | New call: | Old call:                    | New call: |
|-------------------------|-----------|------------------------------|-----------|
| 620 WLFF SC Cayce       | WABX      | 1340 KBBL TX Lubbock         | KFMX      |
| 660 *New AZ Window Rock | KTNN      | WMKE WI Milwaukee            | WBCS      |
| 760 *New MA Leicester   | WVNE      | 1360 KFIV CA Modesto         | KZUN      |
| 900 KREH LA Oakdale     | KICR      | 1380 KZUL AZ Parker          | KLPZ      |
| 980 WRC DC Washington   | WRRC      | 1400 WXAM VA Charlottesville | WKAV      |
| 1080 WZTQ WV Hurricane  | WVKV      | 1440 WQVL SC Greenville      | WSSL      |
| 1100 *New MO Webb City  | KKLL      | 1450 WQCN GA Savannah        | WWAM      |
| 1120 *New CO Limon      | KLIM      | 1490 WKEM FL Immokalee       | WZOR      |
| 1210 *New WY Afton      | KRSV      | 1550 *New WY St. Stephens    | KIGB      |
| 1270 KROI NV Sparks     | KORY      | 1580 WCLS GA Columbus        | WIZY      |
| 1280 KBOF OR Eugene     | KYKN      | 1590 WJBT NY Brockport       | WASB      |
| 1300 WLUY TN Nashville  | WNQM      |                              |           |

### APPLICATIONS FOR NEW STATIONS

|                                       |
|---------------------------------------|
| 700 VA Reston: 1000 D1                |
| 730 FL Lake Placid: 250 D1            |
| 750 MO Eldon: 1000 D1                 |
| 1110 NC Highlands: 10000 D1           |
| 1180 RI Hope Valley: 1000 (500 CH) D1 |
| 1460 FL Lake Mary: 1000/5000 U4       |

### GRANTS FOR NEW STATIONS

|                              |
|------------------------------|
| 880 NV Lovelock: 1000/250 U1 |
| 1210 WY Afton: 5000/250 U1   |

### APPLICATIONS FROM EXISTING FACILITIES

|   |
|---|
| 1000 KMLD CA Vista: night power to 1000 |
| 1300 WIMG NJ Ewing: night power to 5000 |

### GRANTS TO EXISTING FACILITIES

|  |
|--|
| 1170 WDTB MI Diamondale: to 1180 kHz 1000 D1 |
|--|

### OTHERNESS

Interesting to note that the new facility in Afton, WY was also granted a CP for a new FM station (KRSV-FM) at the same time. It is very rare to see grants made for new AM and FM facilities in the same city to the same company at the same time. St. Mary, WV was the last time, that was in 1982, can't remember when it happened before that. And, by the way, we ought to award some sort of prize to the member who can accurately guess how many times calls on 1340 in Milwaukee have been changed to WMKE and WBCS and back. According to my records, it's been WMKE five times and WBCS four times. Anybody know exactly what this is all about?

All for now, more if it happens.

73 and Good DX,

*Derry & BKF*

Jerry Starr & Buffalo K. Foonman

### No more big band sound

WMLJ-AM 1250, Bangor, has dropped the big band sound in favor of a more contemporary music format. According to Johnny Walker, program director, "the market just wasn't large enough to support a highly specialized format such as the 'Music of Your Life'..."

"As an adult, AM-music station, WMLJ will play 'the best pop hits, standards and ballads of the '60s through the '90s,'" Walker said. Featured artists will include Barry Manilow, Barbra Streisand, Kenny Rogers, Steve Lawrence and Eddie Gormet.

The Federal Communications Commission recently granted WMLJ permission to extend operating hours to 6 p.m. daily.

REMINDER: For those of you that write overseas, we remind you that all clubs within ANARC, of which we are part, have agreed to protest to those countries that continue to practice intentional jamming of international shortwave broadcasts. We ask that you send a letter or postcard to stations in those countries protesting their practice of intentional jamming.

# DOMESTIC DX DIGEST

DAVE SCHMIDT  
42 CHELWYNNE RD.  
CASTLE HILLS  
NEW CASTLE, DE 19720

Here is the NRC column which is almost as exciting as a visit to GLEN CAMPBELL, PA (there is such a place!). When sending your items in, please use only one side of the paper, type or neatly write, EST, skip a line (leave some space) between items, and all that jazz. And were off again:

### SPECIAL:

- 680 WCNN GA NORTH ATLANTA - Power is 25000/10000 U2, not on CP yet per call to station. (WIZ-CT)
- 1120 WQXM GA GORDON - 2/5 1805-1816 in the clear w/non stop EZL music, ID for AM & FM, ads then off w/no official s/off. (KG-PA)
- 1210 KASY WA AUBURN - Noted 1/30 running AN w/female anc'r, ID 0412 o/WCAU, now running 2500/1000 U1, soon to be 10000/1000 U1 w/hopes eventually go to 10000/5000 U2. (DKK-CA) Sked now NSP as of 1/30. (BH-WA) Who'll be the 1st to hear them on the east coast? (DS)
- 1300 WLUY TN NASHVILLE - 1/15 1805 female anc'r w/end of news, ID's location, CW music, ex-WMAK. (NAP-AL)
- 1440 WBGA GA BRUNSWICK - 1/23 2045 brief fade in w/local talk, time check, ID, ex-WGIG. (NAP-AL)
- 1560 KGHO WA HOQUIAM-ABERDEEN - 1/18 2100 1st day on PSSA operation w/BPL/EZL music, s/off mentions to tune 95.3 FM, left over from Top 40 days. (BH-WA) I don't care much for leftovers!(DS)
- 1580 WIBY GA COLUMBUS - 2/4 2100 w/ID as 24 hour Christian station, ex-WCLS. (NAP-AL)

### WATI

All Day Country

### DX TESTS:

- 1580 WZKY NC 1/30 poor u/WSRF w/music and ID's. (KG-PA)

WADC--

### FREQUENCY CHECKS:

- 1st Mon - KQIK-1260 2/6 0300-0315 per list w/TT, code ID's. (BH & NH-WA)
- 2nd Fri - WHBG-1360 w/TT per list. (DS-DE)
- WRTA-1240 w/TT per list. (DS-DE)
- WSHP-1480 not noted. (DS-DE)
- WRAW-1340 not heard. (DS-DE)
- 2nd Wed - WHUB-1400 0145-0150 w/TT, ID's each 2 minutes. (DS-DE)

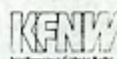

### EMERGENCY BROADCASTS:

- 540 WLIX NY BAY SHORE-ISLIP - 1/18 1811-1824 good w/explanation as to why on past 1800 s/off, snowstorm traffic reports and cancellations, said would be on til 1900. (JB-NY)
- 790 KFGO ND FARGO - 2/4 on non-DA after sunset w/blizzard info. (WCM-ND)
- 1560 WFSP WV KINGWOOD - 1/18 0701 all alone w/ID and storm related information. (JB-NY)

### MIDDAY - MIDNITE:

- 550 WSAU WI WAUSAU - 1/28 1435 fair w/MoR, ads. (SP-WI)
- WSVA VA HARRISONBURG - 1/17 1800 very good w/weather, AP news. (JB-NY)
- WHLM PA BLOOMSBURG - 1/17 1800 faded in o/WSVA w/weather, jingle/ID and rock music. (JB-NY) Hard or soft rock? (DS)
- 560 WFIL PA PHILADELPHIA - 1/17 1807 strong w/weather, oldies and using "Famous 56" slogan, sounded like the old WPIL of 10 to 15 years ago! (JB-NY)
- WFRB MD PROSBURG - 1/29 1700 strong w/dual AM-FM ID into news. (JB)
- 590 WARM PA SCRANTON - 1/21 1642 good in CKEY null w/community calendar activities and notes. (JB-NY) Things to do in Pittston? (DS)
- KID ID IDAHO FALLS - 2/5 2000 much wanted, usually to much KUGN/KHQ but in fairly good tone w/Herb Alpert music, nice jingle/ID, CBS news, KUGN partially nulled. (BH & NH-WA)
- 610 CHNC PQ NEW CARLISLE - 1/17 1855 ID in French, news and weather. (JK)
- 620 WSKQ NJ NEWARK - 1/17 1803 very strong w/"Ka-Coo" slogan in Spanish during what may have been a newscast. (JB-NY)
- 640 KGVW MT BELGRADE - 2/3 1858-1901 Christian music, program schedule change, ID and UPI news, best signal on this guy yet!(WCM-ND)
- 680 WPTF NC RALEIGH - 1/21 2203 good w/NBC news, weather and ID, oldies request program. (SP-WI)
- 730 WJMT WI MERRILL - 1/28 1438 fair w/PSA, ID. (SP-WI)
- WPMW KY MADISONVILLE - 1/31 1839 fading up to a readable level w/ID then CW music. (HJH-PA) Murphy is wrong again! (DS)
- WMTC KY VANCELEVE - 2/4 1807-1815 steady atop channel w/news, sports, weather, short religious program and s/off, hours given as 0600-LSS Mon. thru Sat., 1200 til 1700 Sun. (DS-DE)

1340  
WIZE

730 WLIL TN LENOIR CITY - 2/4 1814 briefly noted in pause of WMTC w/ s/off, to return 0600. (DS-DE)

790 WSGW MI SAGINAW - 1/28 1440 fair w/ID, pop music. (SP-WI)

860 CBFK2 SK SASKATOON - 1/25 2258 "Ici Radio Canada" then local ID in French then back to CBC snow, poor w/CFPR nulled. (NH-WA)

900 CKBI SK PRINCE ALBERT - 1/24 2115 ID into Barry Manilow song, fair w/CJVI nulled. (NH-WA)

930 WSOC NC CHARLOTTE - 2/1 1745-1755 o/all w/weather, TV Channel 9 promo, PSA, pop music and AM 93 announcements. (KG-PA)

1070 WAPI AL BIRMINGHAM - 2/4 1750 surfaced briefly thru the mob w/ID, ad then faded quickly. (TF-CT)

WIBC IN INDIANAPOLIS - 2/4 1855-1900 MoR music, local news, ID, good signal. (TF-CT) Used to be on AN show also until CHOK took over. (DS)

WKDR NY PLATTSBURGH - 2/4 1704-1715 CNN news, ABC sports, long promo on weekend talk show, detailed s/off w/no SSB. (TF-CT)

WNCT NC GREENVILLE - 2/4 1717-1741 CW music, clustered ads, ID. (TF)

WFLI TN LOOKOUT MTN - 2/4 1805 CW music mixing w/WKOK. (TF-CT)

WJKK WV BECKLEY - 2/4 1758 religious program by Unity Radio, ID into full data s/off. (TF-CT) Tony went camping, folks. (DS)

1080 KVNI ID COEUR D'ALENE - 2/5 2004 ID into local news, fair w/KWJJ nulled. (NH-WA)

1110 WTIS FL TAMPA - 2/5 1747-1813 contemporary gospel, ID as the "Love for Inspirational Radio in Tampa Bay", no WBT. (TF-CT)

WJML MI PETOSKEY - 1/25 1810-1815 way o/WBT w/ad, weather, pop music and "JML" ID's, evidently a high power PSA. (KG-PA)

1150 WCRK TN MORRISTOWN - 2/4 1853 promo for St Valentines Contest, CW music, had the channel to itself. (TF-CT) OK, Tony, rub the salt in the wound....it feels so nice-hi! (DS)

WYNS PA LEHIGHTON - 1/31 1740-1800 on PSSA w/pop music, clustered ads, PSA's, weather, and "Y 115" ID's, full data s/off (except for power) and SSB. (KG-PA)

1190 KADE CO BOULDER - 2/5 1919 ID, rock music, no sign of WOWO. (EB-MO)

1200 KPNW ND W. FARGO - 1/25 1650-1700 xlt signal (20 db o/S9) w/call in numbers and add. for prayer requests, religious music.(KG)

1210 KGYN OK GUYMON - 2/1 2331 creaming all the new clear busters w/local news, freq. now a mob scene evenings. (DKK-CA) Riots next? 1/31 2130-2140 someone here w/UNC-Clemson basketball.(JK-MD)

1230 UNID GRASS VALLEY - 2/1 2315-2400 finally heard this one w/basketball game, way u/KTMS/KWSU, lots of KOIT-1260 splash.(DKK-CA)

1250 KNCO CA BELLEVILLE - 1/26 2100 w/sports, weather, ID. (SP-WI)

1260 WIBV IL DEARBORN - 1/25 1825-1835 o/all w/pop music, weathers, ads, and ID. (DKK-CA)

1310 WNIC MI WICKFORD - 1/22 1716 CNN news feed, RI weather (taped), lost to WFEA, 1st time noted here. (TF-CT)

1370 WMYD RI BATON ROUGE - 2/5 1823 good, steady signal w/many contest promo's, CW music w/traces of St. Petersburg, I believe, nothing else in auroral conditions. (HJH-PA)

1410 WMML AL MOBILE - 2/5 1840 all alone w/xlt signal w/CW music and "M and L" ID's, ex-WUNI. (HJH-PA) (TF-CT)

KQV PA PITTSBURGH - 1/28 1710 news, ID, clobbering semi-local WPOP.

1420 WBRD FL BRADENTON - 2/5 1906 ending local news report w/ID, traces of WCOJ at times. (HJH-PA)

WRGG GA COLUMBUS - 2/5 2000 taking WBRD's place w/jingle/ID at this time into CBS news, Bulldogs basketball promo and MYL type music. (HJH-PA)

1430 WIRE IN INDIANAPOLIS - 1/22 2225 good w/CW music, ID. (SP-WI)

1440 KPRO CA RIVERSIDE - 2/1 2235-2255 assumed to be the one w/Lakers-Denver basketball w/KVON, no ID heard. (DKK-CA)

KMED OR MEDFORD - 2/1 2321 w/ads, ID, pop music way u/KVON. (DKK-CA)

1460 KSO IA DES MOINES - 1/21 2214 good w/CW music, ID. (SP-WI)

WPDQ FL JACKSONVILLE - 2/5 1849 good w/B/Sol music, PDQ ID's, nothing else noted here. (HJH-PA)

KENO NV LAS VEGAS - 2/1 1920-1935 w/pop/CW music, blocked 2 minute segments of ads, minor KEST-1450 splash. (DKK-CA)

1470 WMBD IL PEORIA - 1/16 2150 sports and contest promo, 1st time noted here in many years. (JK-MD) Remember the days when they ruled the channel on their AN show? (DS)

1480 WMQM TN MEMPHIS - 1/24, 1/25 1805 w/local news, TN Job Service report, weather and religious program. (JK-MD)

1540 KASA AZ PHOENIX - 2/5 1930 CW/Gospel song fair-good thru KZLA, promo for weekday religious feature, ID. (BH & NH-WA)

WPXZ PA PUNXSUTAWNEY - 1/18 1708-1730 s/off, in the clear after PA news, Paul Harvey report, sports, ads and full data s/off.(KG)

1550 KQXI CO ARVADA - 2/4 1829-1833 o/KQWB w/Christian format, best signal heard yet on this one. (WCM-ND)

1550 WORL TN OAK RIDGE - 1/17 1759 noted w/s/off on truck radio while driving home. (JK-MD) The truck or the radio? (DS)

WJLY PA BRADDOCK - 1/29 1713 good w/ID noted during s/off. (JB-NY)

1560 WAGL SC LANCASTER - 1/21 1709 fair in WQXR fade w/local ad, jingle/ID and CW music. (JB-NY)

1570 WBUZ NY FREDONIA - 1/21 1734 fair w/weather and MoR music, apparently on PSSA power. (JB-NY)

WCLR AL ONEONTA - 2/6 1829 fair w/s/off w/slow "Dixie". (WPT-DC)

WTWB FL AUBURNDALE - 2/6 1814 fair w/s/off w/mention of studio and transmitter locations. (WPT-DC)

WSWV VA PENNINGTON GAP - 1/17 1745 caught s/off on this elusive VA station, VA #116 logged and 30th on 1570 for me. (JK-MD)

1580 WLIM NY PATCOGUE - 1/18 1748-1800 very good w/s/off o/CBJ w/EZL music and storm related cancellations. (JB-NY)

1590 WONX IL EVANSTON - 1/26 2020-2058 fair/good w/Spanish vocals and talk, some WAKR, English ID at 2058. (SP-WI)

MIDNITE - MIDDAY:

550 KAPY CA BAKERSFIELD - 1/30 0435 atop w/PSA then CW music, o/KOY, KSFO-560 was off. (DKK-CA)

560 CJKL ON KIRKLAND LAKE - 1/17 0051 good w/jingle/ID, rock music, all alone on the channel. (JB-NY)

600 KSJB ND JAMESTOWN - 1/17 0041 weak w/jingle/ID, CW music w/WICC.(JB)

610 KDAL MN DULUTH - 1/19 0004 assumed to be them w/weather and giving wind chill as -48 at Duluth/Superior airport, followed by Larry King. (JB-NY)

660 UNID 2/4 0042-0100 noted syndicated Top 40 countdown program, didn't catch name, looped NNW in WNBC's null, who? (REO-MO)

710 KAPZ AR BALD KNOB - 1/18 0838 w/ad, jingle/ID, fair-good signal.(REO)

780 UNID 1/28 2014-2021 talk noted u/WBBM then some type of classical or EZL music, looped WNW, no Cuban present, KROW? (REO-MO) Other than the wrong section....sorry 'bout that! (DS)

880 WMDB TN NASHVILLE - 1/18 0826 w/B/Sol music, xlt signal w/no sign of KRVN. (REO-MO)

910 KOYN MT BILLINGS - 2/2 0829-0832 o/rest w/CW music, ID and agriculture report, 1st time noted. (WCM-MD)

WKCN SC N. CHARLESTON - 2/7, 2/8 0600-0700 mostly atop w/CNN and local news, weather, time and ads. (KG-PA)

\*WSBA PA YORK - 2/8 0035-0056 likely the one running PoP type tones here, usually fair/good here nites. Just CKLY noted strong mixing w/OC and tones. (DS-DE)

940 WECO TN WARTBURG -2/6 0700 noted w/full data s/on w/SSB. (NAP-AL)

990 CBW MB WINNIPEG - 1/18 0821 1/talk show, local ID and mention of Gibbon on 1400, xlt signal. (REO-MO)

1130 KAAB AR BATESVILLE - 1/30 0808-0810 w/local news and weather, good but soon faded. (REO-MO)

WPUB SC CAMDEN - 2/8 0718 w/full data s/on in WNEW null, soon covered by WPYB. (KG-PA)

WPYB NC BENSON - 2/9 0700-0715 strong in WNEW's null w/full data s/on, 23rd Psalm, weather and CW music. (KG-PA)

1170 WOBN NJ LAKEWOOD - 2/4 0645-0650 fairly good in WVVA's null w/vocal SSB, s/on, MoR music, weather, Toms River ad. (KG-PA)

1210 \*WCAU PA PHILADELPHIA - 1/30 0042 noted on ET w/TT. (WPT-DC)

1220 WSLM IN SALEM - 1/21 0720 w/local weather, ID, fair-good in mess.(REO)

1230 \*WEEB PA BASTON - 2/6 0020-0115+ very strong w/TT, no ID's but signal nulled the same as WEEB and their AN program (now CW) was missing. (KG-PA)

KFPW AR PORT SMITH - 2/6 0000 surfaced briefly w/ID, CBS news. (EB-MO)

1250 WKBR NH MANCHESTER - 1/17 0820 good w/spot for car dealer, weather.(JB)

WREN KS TOPKA - 2/6 0101 NBC news, contest promo, ID. (EB-MO)

1280 WEXI FL JACKSONVILLE - 2/8 0635-0659 way o/all on 500 watt PSA w/news, talk and ads. (KG-PA)

1300 \*UNID 2/8 0120-0220+ very strong TT, various pitches way o/WFBR/WERE, no ID's noted, looping NE/SW. (DS-DE)....2/8 0120-0155+ very strong o/WFBR w/TT, no ID's, possibly WXPB but no offfreq. growl noted. (KG-PA) The growl is still here, methinks it was WKCY-VA....(DS)

KMPS WA SEATTLE - 1/30 0300-0400 atop w/CW music, many ID's, w/ slight bits of KWKW. KYNO was off, but on OC. (DKK-CA)

1310 KEIN MT GREAT FALLS - 1/30 0330-0400 w/CW music, KDIA off. (DKK-CA)

KFSB MO JOPLIN - 2/2 0810-0814 w/ID, MO news, good but faded.(REO-MO)

1330 KPH KS WICHITA - 2/2 0816 w/trivia question, good but faded quickly to KUKU. (REO-MO)

KUKU MO WILLOW SPRINGS - 2/2 0816-0819 fair-good w/talk, local news, local ads. (REO-MO)

1340 WMRK AL SELMA - 2/5 0055 clear ID in noise while hanging out here, faded up w/ID then quickly gone. (JK-MD)

# INTERNATIONAL DX DIGEST

CHUCK HUTTON  
1035 LATHAM ROAD  
DECATUR, GA 30033  
(404) 633-1198  
BEFORE 2300 ELT

Times are GMT. For ELT subtract 5 hours. Deadlines are usually Monday

- 6
- 1340 WTRN PA TYRONE - 1/18 0738 noted briefly w/ID and sports. (JB-NY)  
 KKBK NM AZTEC - 1/29 0758-0802 o/din w/Country Crossroads, ID and AP news. (WCM-ND)
- 1350 KDIO MN ORTONVILLE - 1/30 0833-0840 alone w/MoR format. (WCM-ND)  
 1360 KPQP CA SAN DIEGO - 1/30 0330 another saught for call change, pop's up w/K-Pop ID thru KPIV/heavy KERN-1370 splash. (DKK-CA)
- KAMT WA TACOMA - 1/30 0300 w/full data s/off, to return 0745, so likely AN6, off MM's. (DKK-CA)  
 KXOL TX FT WORTH - 2/2 0825 good w/ID and time check, temp check, into CW music. (REO-MO)
- 1380 \*WGUS SC N AUGUSTA - 1/23 0135-0145+ way o/all w/ET w/102 FM audio.(KG)  
 1400 WMSL AL DECATUR - 2/7 0113 w/ID u/KTTS. (EB-MO)  
 1410 KLEM IA LE MARS - 2/1 0912-0915 o/rest w/community notes and ad.(WCM)  
 1420 WHEZ WV KENOVA - 1/23 0124-0140 in the clear w/MYL type music, PSA, and ad for write in offer giving add. & calls for WTOR, Huntington, WV, ID's were for WHEZ! (KG-PA)
- WRCG GA COLUMBUS - 1/23 0140 briefly atop w/ID and slogan "The Great Entertainer". (KG-PA)  
 KITI WA CENTRALIA - 2/4 0330-0505 noted in/out w/others w/pop/rock music, female anc'r, ID on hour and AI news. (DKK-CA) My! 2/7 0008 two short blasts of 1000 hertz tone noted, strong signal, off w/no ID, WLET f/c listed at this time. (DS-DE)
- \*UNID  
 1450 WTSV VT BRATTLEBORO - 2/4 0137 noted atop several times w/ID, only one worth noting. (HJH-PA)  
 1460 \*UNID 1/29 0110-0230+ w/TT of various hertz, no ID, strong o/WCMB and looped west. (KG-PA)
- 1470 CJVB BC VANCOUVER - 1/31 0930-0944 barging atop w/ads, promos, ID, news/weather into polka which led to more or less pop music, then into sports report, 1st time noted. (DKK-CA) Fun city!
- 1490 WVGB SC BEAUFORT - 1/30 0027 fair w/ID by female. (WPT-DC)  
 1510 KKNW WA MOUNTLAKE TERRACE - 2/6 1135 faded up o/KGA w/ID and rock music, non stop but soon lost. (BH & NH -WA)
- 1530 KCTT AR YELLEVILLE - 1/21 0802 fair w/WCKY w/ID, temp. check. (REO-MO)  
 1560 KLTJ MO MACON - 1/30 0830 w/ad, station ID, CW music, good but soon lost to KTUI. (REO-MO)
- 1580 \*WSRF FL FT LAUDERDALE - 2/3 0036 xint o/CBJ w/weather, Surf 16 ID's and ad, signal dropped abruptly at times so may have been an ET during Reg. sked. (JB-NY) T'was indeed! (DS)
- \*WPGC MD MORNINGSIDE - 1/16 0548 weak w/ID, music on ET. (JK-MD)  
 \*WLMJ NY PATCHOGUE - 1/30 0012 noted w/ID on ET. (JK-MD)  
 1600 KBBX UT CENTERVILLE - 1/31 0914 atop ending religious program, ID into another program, caught tail end of s/off later in day, 25 minutes after scheduled time!). (DKK-ca.....

## TIS:

- 1610 KIB744 PA GETTYSBURG - 1/23 2103 noted evenings with Anguilla weak or noted present....run by national park service w/directions to gettysburg battle field and eisenhower farm....local here days....jk-md....

paul swearingen dept....

now this thing finally gives up....can't shift into caps.....so will send the credits along for mike to type up and hope it comes out in a language close to english....we'll hold rk's beacon report and a load of station addresses til next week.....good dx....

|        |   |  |
|--------|---|--|
| KG-PA  | Kermit Geary, Walnut Port, PA               | R390A, HQ180, LW, SM2                  |
| BH-WA  | Bill Hardy, Aberdeen, WA                    | FRG-7, SM-1                            |
| NH-WA  | Nancy Hardy, Aberdeen, WA                   | FRG-7, SM-1                            |
| WIZ-CT | The Wiz Wizard of Poughonock, CT            | HQ145, Looped.                         |
| HJH-PA | Harry Hayes, Wilkes Barre, PA               | HQ-180, SM-2                           |
| EB-MO  | Eric Bueneman, Hazelwood, MO                | Superadio 11, SM-2                     |
| DKK-CA | Don Kaskey, San Francisco, CA               | HQ140x, SM-2                           |
| JK-MD  | Joe Kureth, Uniontown, MD                   | SX43, Short LW                         |
| WPT-DC | Bill Townshend, Wash. DC                    | ICFS5W                                 |
| REO-MO | Rick Overmann, Florissade, MO               | Superadio                              |
| NAP-AL | Neal Perdue, Falkville, AL                  | R390A, RF2900, Kowalski Loop, LW       |
| SP-WI  | Sheryl (The Girl) Paszkiewicz Manitowoc, WI | DX302, DX400, MFJ-1020 Loop Inside, LW |
| JB-NY  | Jerry Bond, Rochester, NY                   | HQ140XA, Loop                          |
| TF-CT  | Tony Fitcherbert, Fairfield, CT             | ICFS5W, RF2900                         |
| WCM-ND | Bill Moser, Wisner, ND                      | Zenith 731, Loop, LW                   |

(D.S. - The bill is on it's way, hi. -HQ)

- 540 NICARAGUA R. Corporacion, Managua YANU 0230-0245 "Radio Corporacion, transmitiendo beisbol" and play-by-plays, xint 2/2. (Krueger)
- 550 VENEZUELA YVKE R. Mundial Caracas on w/sports pgm covering South America and Caribbean areas, ID at 0352 followed by "Musica Mundial" LA mx 0348 2/9, good. (Frodge)
- 555 NICARAGUA YNS R. Diez y Nueve de Julio, Chinandega man w/EE pop mx, women with ID, QRM de 1st CW 0451 2/1. Poor. (Krueger)
- 580 JAMAICA Geline RJR with rei pgm, RJR promo and sds, Caribbean mx, 0501 possible SS snner (not likely at all-CH) 0455 1/30 poor. (Frodge)
- 580 VENEZUELA YVME LV de 1a Fe Maracibo with SID and sung anthem 0400-0404, man with full ID 2/9 good. (Frodge)
- 620 CUBA CMDA/CMGN Colon man with noticias de Cuba to 0305, R. Hebeide ID and H. Hebeide Cadena Nacional ID, man with beisbol after mx // 570 0300 2/1 good. (Frodge)
- 650 HONDURAS LV de Centro America HRVW San Pedro Sula 0250-0304 "ests es LV de Centro America en San Pedro Sula, La Voz de Honduras" during newscst, xint 2/2. (Krueger)
- 655 EE SALVADOR San Salvador YSS man and woman with news and sports, feature on a German visitor, ID and futbol pgm 0405 1/10 fair. (Frodge)
- 660 HONDURAS LV de Honduras HRN, Tegucigalpa 0304-0307 xint w/SS mx, ID 2/2. (Krueger)
- 670 CUBA CMBC R. Liberacion, Arroyo Arena with radio y TV cubana promos by men and woman, R. Liberacion ID also SS beisbol at 0130 after pips 0125 1/21 fair. (Frodge)
- 720 UNID men with LA beisbol, ID as "Emisora Boliver" at 0455 2/9 w/ WUN, poor. (Frodge)
- 690 HONDURAS R. honduras, Tegucigalpa 0344-0555 good w/EE and SS MoR vocals, national mx, "Buenos noches Honduras; buenos noches centro-americanos, desde Tegucigalpa, Radio Honduras" our not s/off; went back to news, 1st 2/9. (Krueger)
- 940 HAWAII Weipshu AHW 2/6 0913 fair signal w/deep fades, caw mx, promos for syndicated shows, slogans include "K-Dee-On, country radio, AM-94". Much stronger for legal ID 1000 and back to caw. Rare KPRE SP made this possible, last logged this as AHW before KPRE went NSP. Cwlb weak to nil. (The Hardy family)
- 1000 MEXICO XBOY Mexico 0300-0308 full call letter ID 0300 into mx summary and "La nucleo Oro" slogan, xint 2/9. (Krueger)
- 1012 COLOMBIA HJZD R. Panzenu, Monteria ex 1020 per WRTVH; reported at 1000 in the 1/9/04 DAK-many ID's by men, some sounded like "Radio Panzenu-ur"-lite SS vocal mx. Detected by severe net at 1010 o/ CRRB. "Radio Panzenu es la emisora...equi Monteria, la capital (de Cordoba)...squi Radio Panzenu" it and net disappeared at 0354 2/1, good. (Frodge)
- 1015 UNID LA 0312-0320 strong carrier but low modulation, looping more SA than CA so maybe Ecuador. Only item noted was Bonnie Tyler's "Total eclipse of the Heart" 2/9. (Krueger)
- 1040 COLOMBIA Barranquilla in very strong 2/b 0250 w/many Caracol mentions, 0259 into noticias. (N. Hardy)
- 1040 COLOMBIA HJAI R. Tropical, Barranquilla man with beisbol, one team is Hojas o/u HION and WHO 0352 2/2 poor. (Frodge)
- 1040 DOMINICAN REPUBLIC HION Santo Domingo R. Central ID and headlines then man with MoR vocals o/u HJAI and WHO 0400 2/2 poor. (Frodge)
- 1070 CUBA Gusntansmo CEML men with beisbol-possible Radio Rebelde relAY AND WOMAN W/NEWS AT #8) )#88 07U CHOK 0338 2/2 fair. (Frodge)
- 1072 COLOMBIA HJAG Em. Atlantico, Barranquilla noted as 1070v in WRTVH; detected by severe net on CHOK. "Atlantico" ID's, LA vocals, man and woman anners, severe fades 0406 2/7. Heard again but much weaker at 0307 2/9. Good. (Frodge)
- 1080 CUBA CHCU R. Cadena Habana, Guines man and woman w/EZL mx, pro Nicaragua spots, RCN ID 0301 and mx continues 0240 2/7 fair. (Frodge)
- 1110 HAWAII Kinei KHEI 2/6 1600 ending instrumental mx, legal ID by man who then read the 6 o'clock news report. Poor, barely made out the ID, but definitely Hawaii thanks to time check, loop bearing, good ex to Hawaii all morning, and daylight paths east of us. No sign of KBND; KPIP's SS mx nulled. (Hardy family)
- 1260 MEXICO R. Capital XEL, Mexico 0141-0153 fair over/under the 3P Miamian w/ads, man carted "Radio Capital" ID's, SS vocals 2/9. (Krueger)

1555 CAYMAN ISLANDS Gun Bluff men with call-in pgm, GRM de WQXR 0111 2/7, poor. (Prodge)

???? MONTERRAT R. Canada International (via Radio Antilles) 2259-2330 fair w/conclusion of RR, IS then RE news. In regards to 10XD #17 this is an experimental HCI relay from R. Antilles on 740, 930 and 1450 (St. Vincent) 2230-2330. (Krueger) And on what frequency might I ask?? CH

The faithful few, muchly appreciated this time around!

Hill Herdy/Nancy Herdy Aberdeen WA PHG?, SK1  
 Harold Prodge Midland, MI DXJ02, 185' LW, loop  
 Terry Krueger Largo, FLA NYO, RF2900



This latest edition (the 5th) contains full details of frequencies, powers, schedules, transmitter sites, slogans, programming, addresses, plus latest QSL policies. Much of the information has been obtained directly from the stations, and is unavailable in this form in any other publication. New information on South Pacific stations is given.

The new Guide also lists proposed new stations, and new channels, as an outcome of the Geneva Plan for mediumwave broadcasting. It includes a special listing of Australian and New Zealand stations, arranged in order of call-sign. Relay facilities are also featured, with Networking information. The Guide is 36 pages, offset printed.

All previous editions of the Mediumwave Guide have proven very popular with DX listeners around the world, and all earlier issues were sold out. The Guide is being made available to communications listeners on a world-wide basis, and is available from:

Price: Within Australia: A\$4.00.  
 Other countries:

- (a) Surface mail: A\$4.00 (or US\$4.00 or 9 IRC's);
- (b) Airmail: A\$5.00 (or US\$5.00 or 12 IRC's).

Payment can be made in Australian or American banknotes, IRC's, Bank-draft, or International Money Order. Personal cheques, issued by banks outside of Australia, cannot be accepted. Payments should be made for credit of the AUSTRALIAN RADIO DX CLUB.

- SAMPLE PAGE -

| Freq (MHz) | Call | Location                             | Power (W) | Notes                    |
|------------|------|--------------------------------------|-----------|--------------------------|
| 1000       | 422  | Burman (St. James Island, Australia) | 50        | 24 hours 24/7 "Radio 10" |
| 1010       | 422  | St. James Island, Australia          | 50        | 24 hours 24/7 "Radio 10" |
| 1015       | 422  | St. James Island, Australia          | 50        | 24 hours 24/7 "Radio 10" |
| 1020       | 422  | St. James Island, Australia          | 50        | 24 hours 24/7 "Radio 10" |
| 1025       | 422  | St. James Island, Australia          | 50        | 24 hours 24/7 "Radio 10" |
| 1030       | 422  | St. James Island, Australia          | 50        | 24 hours 24/7 "Radio 10" |
| 1035       | 422  | St. James Island, Australia          | 50        | 24 hours 24/7 "Radio 10" |
| 1040       | 422  | St. James Island, Australia          | 50        | 24 hours 24/7 "Radio 10" |
| 1045       | 422  | St. James Island, Australia          | 50        | 24 hours 24/7 "Radio 10" |
| 1050       | 422  | St. James Island, Australia          | 50        | 24 hours 24/7 "Radio 10" |
| 1055       | 422  | St. James Island, Australia          | 50        | 24 hours 24/7 "Radio 10" |
| 1060       | 422  | St. James Island, Australia          | 50        | 24 hours 24/7 "Radio 10" |
| 1065       | 422  | St. James Island, Australia          | 50        | 24 hours 24/7 "Radio 10" |
| 1070       | 422  | St. James Island, Australia          | 50        | 24 hours 24/7 "Radio 10" |
| 1075       | 422  | St. James Island, Australia          | 50        | 24 hours 24/7 "Radio 10" |
| 1080       | 422  | St. James Island, Australia          | 50        | 24 hours 24/7 "Radio 10" |
| 1085       | 422  | St. James Island, Australia          | 50        | 24 hours 24/7 "Radio 10" |
| 1090       | 422  | St. James Island, Australia          | 50        | 24 hours 24/7 "Radio 10" |
| 1095       | 422  | St. James Island, Australia          | 50        | 24 hours 24/7 "Radio 10" |
| 1100       | 422  | St. James Island, Australia          | 50        | 24 hours 24/7 "Radio 10" |
| 1105       | 422  | St. James Island, Australia          | 50        | 24 hours 24/7 "Radio 10" |
| 1110       | 422  | St. James Island, Australia          | 50        | 24 hours 24/7 "Radio 10" |
| 1115       | 422  | St. James Island, Australia          | 50        | 24 hours 24/7 "Radio 10" |
| 1120       | 422  | St. James Island, Australia          | 50        | 24 hours 24/7 "Radio 10" |
| 1125       | 422  | St. James Island, Australia          | 50        | 24 hours 24/7 "Radio 10" |
| 1130       | 422  | St. James Island, Australia          | 50        | 24 hours 24/7 "Radio 10" |
| 1135       | 422  | St. James Island, Australia          | 50        | 24 hours 24/7 "Radio 10" |
| 1140       | 422  | St. James Island, Australia          | 50        | 24 hours 24/7 "Radio 10" |
| 1145       | 422  | St. James Island, Australia          | 50        | 24 hours 24/7 "Radio 10" |
| 1150       | 422  | St. James Island, Australia          | 50        | 24 hours 24/7 "Radio 10" |
| 1155       | 422  | St. James Island, Australia          | 50        | 24 hours 24/7 "Radio 10" |
| 1160       | 422  | St. James Island, Australia          | 50        | 24 hours 24/7 "Radio 10" |
| 1165       | 422  | St. James Island, Australia          | 50        | 24 hours 24/7 "Radio 10" |
| 1170       | 422  | St. James Island, Australia          | 50        | 24 hours 24/7 "Radio 10" |
| 1175       | 422  | St. James Island, Australia          | 50        | 24 hours 24/7 "Radio 10" |
| 1180       | 422  | St. James Island, Australia          | 50        | 24 hours 24/7 "Radio 10" |
| 1185       | 422  | St. James Island, Australia          | 50        | 24 hours 24/7 "Radio 10" |
| 1190       | 422  | St. James Island, Australia          | 50        | 24 hours 24/7 "Radio 10" |
| 1195       | 422  | St. James Island, Australia          | 50        | 24 hours 24/7 "Radio 10" |
| 1200       | 422  | St. James Island, Australia          | 50        | 24 hours 24/7 "Radio 10" |

SEVEN PASSIVE TUNERS

Mark Connelly - WAIION DX Labs - January 1984

A passive tuner has preselection as its primary function. Preselection is of increasing importance as few DXers live in areas with no strong local stations capable of spur/image production. Preselection is especially useful to DXers using lower-priced solid-state receivers having wideband input RF amplification. Such receivers do not offer the 'crunch-proof' operation of some of the 'top-buck' solid-state gear and of many of the old tube-type stalwarts such as the HQ-180A and the R390A. With any decent length of wire capable of capturing weak DX, many receivers crumple up like an accordion and give urban and suburban dxers headache-producing local-station images and spurs instead of the desired DX.

Use of a tuner can go a long way towards solving such problems. One must remember that the gain of a passive tuner is generally about unity: the received signal is about the same as if the wire were connected directly to the receiver -- BUT, with the important consideration that, in general, spurs will be removed (thereby allowing longer-than-previously-useful wires to be utilized).

For those wanting actual gain, use either an active tuner such as APT-2 or APT-3, or use a Broadband Amplifier module between a passive tuner's output and the receiver's input. Figure 8 of the 'Modular Phasing Systems' article gives a schematic for a broadband amplifier card which may be readily mounted in a mini-box. Changing R5 of that card from 100 ohms to 33 ohms will beef up the gain a bit more. The amplifier's output should be routed out through a low-value resistor (about 33 ohms) in series with a DC-blocking capacitor (.1 uF).

The seven tuners to follow fall into two overall groups: Passive Series-L-C Tuners (PST's) and Passive Parallel-L-C Tuners (PPT's).

PST's have been the traditional favorite as phasing-unit input tuners. As they are tightly coupled to the antenna, tuning ranges are influenced greatly by antenna length: if many different length aeriels are to be used, this may be perceived as a disadvantage, as the difficulty in memorizing or looking up a whole batch of frequency-range switch position tables would tend to slow down tuning agility in a good-opening fast-frequency-hopping type operation. The advantage of the PST, because of tighter coupling, is somewhat more signal coupled to the receiver, phaser output module, or broadband amplifier input.

PPT's offer somewhat looser coupling. The critical factor is how much antenna-to-tank coupling capacitance will produce maximum tuner output consistent with spur-rejection and good Q. In PPT designs, 47 pF generally is best throughout the MW broadcast band, although for short aeriels operated on the lower half of the band, better results could be obtained with greater coupling capacitance, in the order of 100 pF or more. Similarly, if Beverage-length aeriels are being used, tuning sharpness above 1 MHz could be improved somewhat by decreasing the coupling capacitor to approximately 27 pF. In general, 47 pF does well for the vast majority of medium-wave PPT situations encountered.

A big advantage of the PPT is much more reliable frequency range switch settings, settings less influenced by antenna length than those of PST-style tuners. Furthermore, PPT's often provide sharper tuning (when not Q-spoiled) than PST's.

It has been found that use of inductive voltage divider schemes has been of great value in making the tuners 'work into' a wide variety of output impedances.

A big problem with many tuner designs heretofore published in DX magazines is that a given tuner will work well with some receivers and yet be useless with others.

Some receivers have a very low input impedance. A portable receiver using a ferrite rod antenna often uses a coupling coil of as few as 3 turns on the rod. That coil is usually grounded on one end; the other end goes to the external antenna jack. The input impedance of such a configuration may be less than an ohm DC resistance in series with a small inductance, perhaps less than 10 uH.

Many communications receivers have input impedances in the order of 50 to 75 ohms, primarily resistive.

Car radios may have very high input impedances, sometimes principally reactive.

The inductive voltage divider principle permits tuner operation with most conceivable receiver, amplifier, or phaser-output-module input impedances. Some signal is wasted in this process, but by careful design, loss can be minimized. Using an inductance-division ratio of between 8:1 and 16:1 has proved to offer optimal performance.

Passive tuners, in general, are to be used with aeriels of minimum length approximately 1/16 of a wavelength (e.g. 18.8 meters / 61.5 feet at 1 MHz.). Use of a broadband amplifier module after the tuner may allow somewhat shorter wires to be tuned. Really short wires, car whips, bedsprings, etc. should be tuned with an FET-input active tuner such as APT-2 or APT-3.

10

All passive tuners described hereafter offer an output-level 'gain' potentiometer (R2 of Figures 1-4, 6, 7; R1 of Figure 5). This pot is necessary so that the tuner can be operated into a receiver or amplifier without overloading it with potentially-spur-causing signals on frequencies other than that of operation. This pot adjusts the level of RF out of the tuner without noticeably influencing tank circuit Q or the peak-yielding settings of the tuning capacitor and frequency range switch.

All tuners except the Mini-MWPPT (Figure 5) provide a second pot [R1] which is used to spoil Q as well as to adjust 'gain'. This pot is generally used only in PHASING applications: set it to CCW (max. Q) otherwise.

The main tuning capacitor (C1 of all tuners) can be either a miniature mica-dielectric type (e.g. Mouser 24TR210 or GC/Calctro A1-232) or the larger air-dielectric type of metal construction (e.g. Mouser 524-A1-227 or GC/Calctro A1-227). If the miniature type is used, the tuner can be constructed in Radio Shack's largest mini-box, the 270-238 (approx. 5.25 x 3 x 2.125 inch). Use of the air-variable capacitor will mandate a larger chassis: the Bud CU-3005A / Mouser 537-TF-779 (5 x 4 x 3 inch) would then be the preferred box.

Note that PST's require C1 to be 'floated above ground' (= isolated from contact with chassis). See the recent MWDX-2 article on ideas of how to accomplish this.

The vernier, or fine, tuning capacitor (C2 of Figures 1-4, 6, 7) is used primarily in phasing applications. It, and its series fixed capacitor, may be eliminated from the tuner if no phasing is to be done.

Choices of vernier capacitors include the Mouser 530-189-0565-1 (no series cap. needed) and the GC/Calctro A1-225. The A1-225 is larger than the Mouser unit (it also costs more), but it is easier to mount in a secure fashion; it also turns more easily.

Inductors greater than 1 mH (1000 uH) should be Mouser 43LH or 43LJ series. Those of 1000 uH or less can be Mouser 43 HH, 43 LR, or 43 LS series; or equivalent units made by J.W. Miller, Nytronics, Delevan, Caddell-Burns, Dale, Krystinel, or other vendors.

Function switches (S1, all tuners) are simple DPDT (on/off/on) toggle types (e.g. Radio Shack 275-620). S2 of Figures 5 and 7 can be the same type switch. The 6-position / 2-pole frequency range switches (S3 of Figures 1-4, 6, 7) are Radio Shack 275-1386. Pots, fixed resistors, and fixed capacitors may be obtained from a variety of sources.

The antenna-input jack (J1) and the ground-input jack (J2) are Radio Shack 174-662 insulated binding-post banana jacks: use the red one for J1 and the black one for J2. Space J1 and J2 0.75 inch apart to permit the use of double-plug connectors and adapters.

RF-output connector J3 (all tuners) can be female BNC, UHF, RCA phono, N, SMA, F, or other coaxial type. J4 (figures 3, 4, and 5) is Radio Shack 274-712 car jack.

Initial setup of a completed tuner entails setting length switch to normal, all pots to fully counterclockwise, and the tuning and vernier capacitors to center (half-meshed). Running the frequency-range switch through its positions will help to ascertain the proper range; that with the strongest wanted-frequency signal. The Dier should make a 'look-up table' for frequency-range switch settings (similar to Table 1 of the recent APT-2 article). If wires of considerably-different lengths will be used, more than one such table may be needed - especially with PST's.

Of interest to beginners is Figure 5, the 'Mini-MWPPT'. This tuner is about the simplest design possible. Anyone should be able to throw this thing together in an hour or less. Parts expenditure should be under \$25. Every MW DXer who uses a longwire antenna should make one of these boxes. This is meant to be a 'bare-bones' type module designed for easy operation. The Mini-MWPPT is not meant to be an input to a phasing system; the Q-pot and several other phasing-oriented features have been omitted for the sake of simplicity.

All tuners described work best when operated into a receiver having a metal chassis shielding internal receiver components. Operation with portables using ferrite rod aerials may be influenced somewhat by the direct pickup of the ferrite rod. Sometimes offsetting tuner's tuning capacitor from peak can cause a dip - this is a crude sort of phasing whereby the tuner's output is phased against the ferrite rod's direct pickup. Such phasing is usually a hit-or-miss proposition, not something as dependable as the operation of a dual-tuner phasing unit.

Good grounding is important, especially for the proper operation of PST type tuners. The metal chassis of communications receivers plugged into mains is often a sufficient ground. Otherwise, use a pipe, mains, rod, vehicle chassis or other suitable ground connection. An otherwise - unused longwire or Beverage can sometimes be used as a 'dummy ground' at poor-conductivity DXpedition sites lacking other readily-available grounds.

The figures to follow should provide good starting points for experimenters -- these include:

- Figure 1 LWPPT (Longwave Passive-Parallel-L-C Tuner)
- Figure 2 LWPST (Longwave Passive-Series-L-C Tuner)
- Figure 3 MWPPT (Medium-wave Passive-Parallel-L-C Tuner)
- Figure 4 MWPST (Medium-wave Passive-Series-L-C Tuner)
- Figure 5 Mini-MWPPT (Miniature MW Passive-Parallel-L-C Tuner)
- Figure 6 TBPPT (Tropical-Band Passive-Parallel-L-C Tuner)
- Figure 7 TBPST (Tropical-Band Passive-Series-L-C Tuner)

FIGURE 1

Design Band 130-600 KHz.

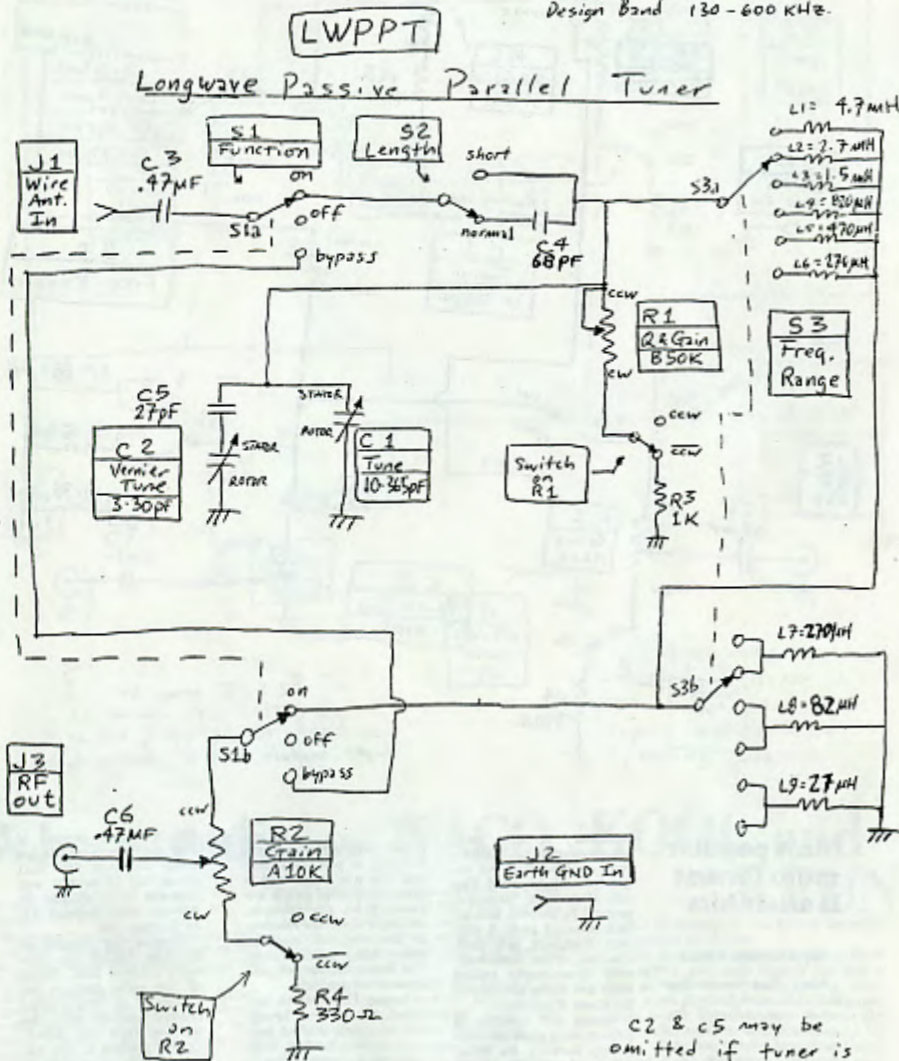

C2 & C5 may be omitted if tuner is not to be used as an input module in a phasing system.

⑫ FIGURE 2

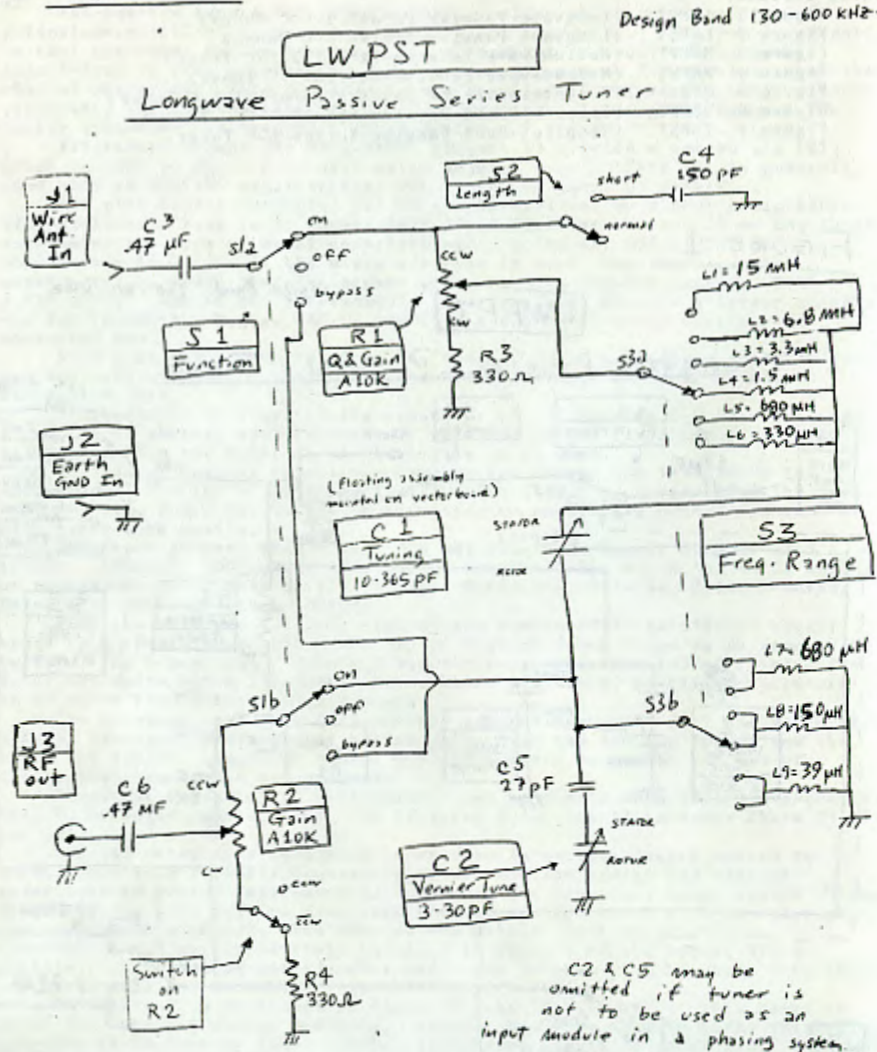

### Most popular radio format is adult hits

By Michael Weiss

More than one in four U.S. radio stations carry an adult contemporary format—a middle-of-the-road mixture of current and past favorites—according to a survey by the 2,000-member National Radio Broadcasters Association.

The Washington-based trade organization polled nearly 7,600 stations nationwide and obtained responses from 3,497 outlets.

Of FM stations surveyed, 27 percent have adult con-

temporary formats. Next are country music, 21 percent; contemporary hit radio (previously called Top 40), 17 percent; "beautiful music," 13 percent; and album-oriented rock, 9 percent. Religious, soft rock, classical, urban contemporary (previously called soul) and oldies are carried by about 3 percent.

Among AM stations, 28 percent have adult contemporary formats. An equal number broadcast country music. Other formats are news-talk, 9 percent; oldies, 7 percent; contemporary hit radio, 5 percent; and big band, 5 percent. Religious, urban contemporary, "beautiful music" and soft rock are carried by less than 4 percent of those surveyed.

The numbers of outlets carrying a particular format are not necessarily a measure of what people are listening to. For example, although there are relatively few news-talk stations, many enjoy good ratings. The format is, however, expensive to produce.

Among FM stations surveyed, 96 percent broadcast in stereo, while 4 percent of AM outlets have adopted the new technology. AM stereo receivers are not yet widely available. The study noted that "although there is some interest in its [AM stereo's] future prospects," it is not overwhelming.

More than half of AM outlets target programming to people 25 to 54 years

old. About 35 percent of FM stations also design their formats for that group, but 32 percent seek listeners 18 to 49, and 21 percent have targeted 18- to 34-year-olds.

Despite the changes in listening habits, the survey's authors said, "Most of the radio stations responding to our survey seemed content with the formats they are airing. Only 4 percent of the stations indicated an interest in changing formats."

Dallas Morning News/  
Independent Press

CHICAGO SUN-TIMES

FIGURE 3

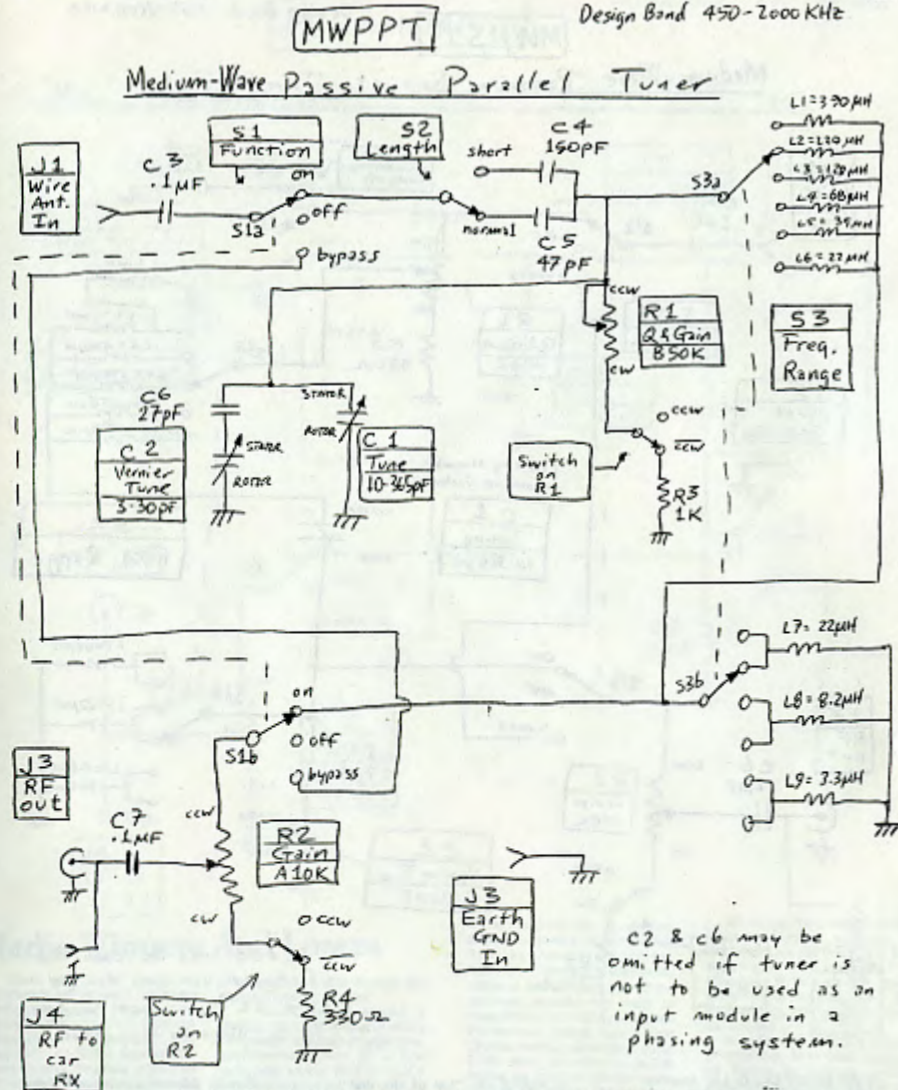

## Where radio is WACO, KOOL and KFUN

By PENNY PAGANO  
Los Angeles Times Service

Radio station WACO is in Waco, Texas — that makes sense. And station KOOL is right where you'd expect it, in Cody, Wyo.

But did you know that KBET, KENO, KLUC and KFUN are all in Las Vegas? Or that WCOW is in the middle of dairy country in Sparta, Wis., and KORN is in the corn capital of Mitchell, S.D.?

And then there are the acronyms. In Chicago, WLS meant the "world's largest store" when the station was owned by Sears, Roebuck and Co., and WGN was named by its original owner, the Chicago Tribune, for the "world's greatest newspaper."

Broadcast call signs, often called the license plates of the radio highway, are the letters assigned by the Federal Com-

munications Commission to identify the nation's more than 9,350 radio stations and 1,400 television stations.

They also trace the early days of radio and leave clues about how the country has grown.

"There isn't much of this folklore and tradition written down," says former FCC commissioner Rosel H. Hyde. "You have to find some of the survivors."

An international agreement in 1927 first apportioned letters among nations. U.S. domestic radio stations were assigned K and W. Canada has C and Mexico is X.

KDKA in Pittsburgh was one of the earliest stations on the air.

The first stations were assigned three call letters, and radio experts say only a few of them had much meaning when they were originally issued. For example, when a Des Moines station went on the air in 1924 without call letters, early listeners wanted to know who was broadcasting. So the station — where Ronald "Dutch" Reagan became a sports announcer — adopted the letters WHO.

With the proliferation of radio stations in the 1920s, the need for more call signs led to the current four-letter combinations.

Some station owners carved their initials on their radio frequencies. WMAL in Washington, D.C., stood for the M.A.

MWPST

Design Band 450-2000 KHz.

Medium-Wave Passive Series Tuner

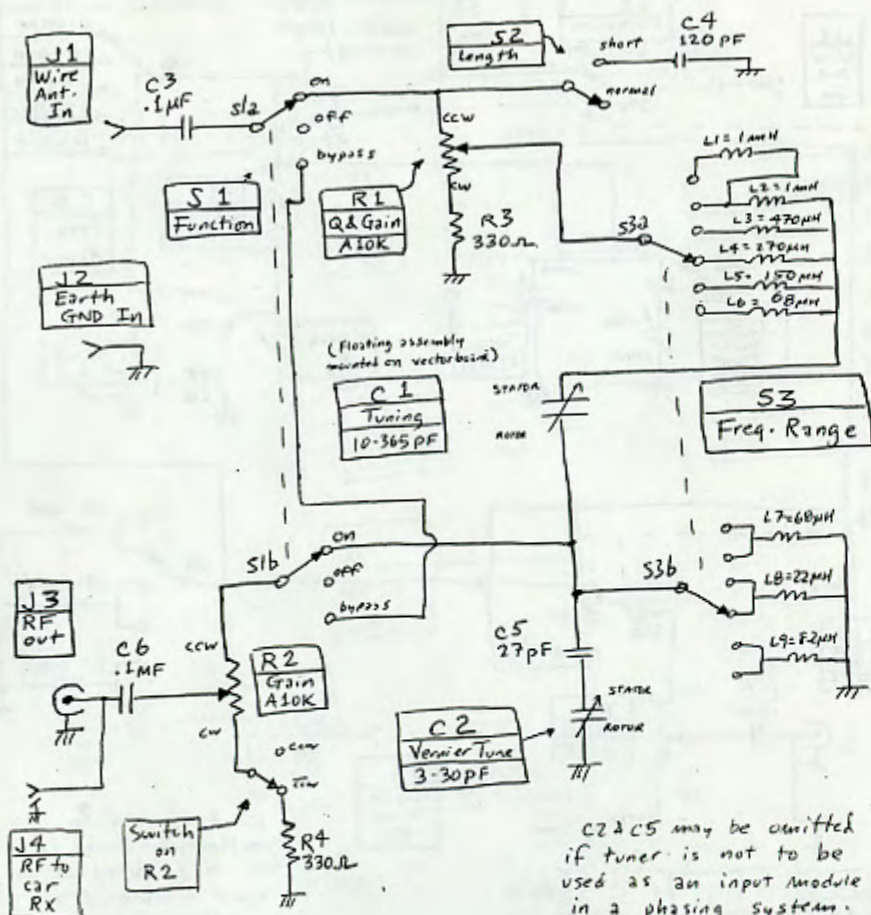

Leese Optical Co. in Los Angeles. KFAC's owner was the Fuller Auburn Cord automobile dealership. WEVD in New York was launched as a memorial to Eugene V. Debs and the Socialist Workers Party. WGAY in Washington was named for its founder, western music promoter Connie B. Gay.

When the desired letters already were assigned to other stations or sometimes to ships at sea, they were brokered, bought and moved.

Ted Turner, for example, wanted to use the letters WTBS for his Atlanta television station, but he found that they already belonged to a small FM radio station owned by the Massachusetts Institute of Technology. "We wanted to be TBS, just like CBS," he recalled recently. Turner got his way. "I gave them \$50,000 to release the call letters," he said.

Similarly, when a Washington station wanted the letters WTOP

to signify the "top of the dial," they got the letters from a police station in the Midwest.

Some stations like to glorify local landmarks: the San Francisco cable cars are temporarily out of commission for repairs, but listeners can still tune in to radio station KABL. Where weather is important, it turns up in call letters, as in KSNO in Aspen, Colo.; KSUN and KOOL in Phoenix; and WETT in Ocean City, Md.

WSB in Atlanta stands for Welcome South, Brother; WIOD in Miami stands for Wonderful Isle of Dreams; KIMN in Denver used to be KFEL, which its original owner, Gene O'Fallon, reportedly insisted stood for "can't find enough liquor." KFWB in Los Angeles, now owned by Westinghouse Broadcasting, originally belonged to Warner Brothers, and the letters stood for Keep Filming. Warner Brothers. During World

War II, the message became Keep Fighting, Warner Brothers.

Traditionally, call letters have been assigned and cleared for good taste by the FCC. In 1963, the commission gave itself new authority to settle disputes over whether one sign too closely resembled another.

Earlier this month, in the spirit of deregulation, the FCC voted to relinquish its role as the arbiter of good taste and arbitrator of disputes. In the future, disputes will be left to the courts, and the FCC's only job will be to issue new call signs and make sure that they are not already in use.

Last year the FCC reversed an earlier decision and approved the letters WSEX for a station in Arlington, Ill. Other stations are already on the air with call letters including KOKE in Austin, WYNO in Nelsonville, Ohio, and WSUX in Seaford, Del.

VIA S. KAMP

Mini-MWPPT

Design Band 500-1700 KHz

"Mini" Medium-Wave Passive Parallel Tuner

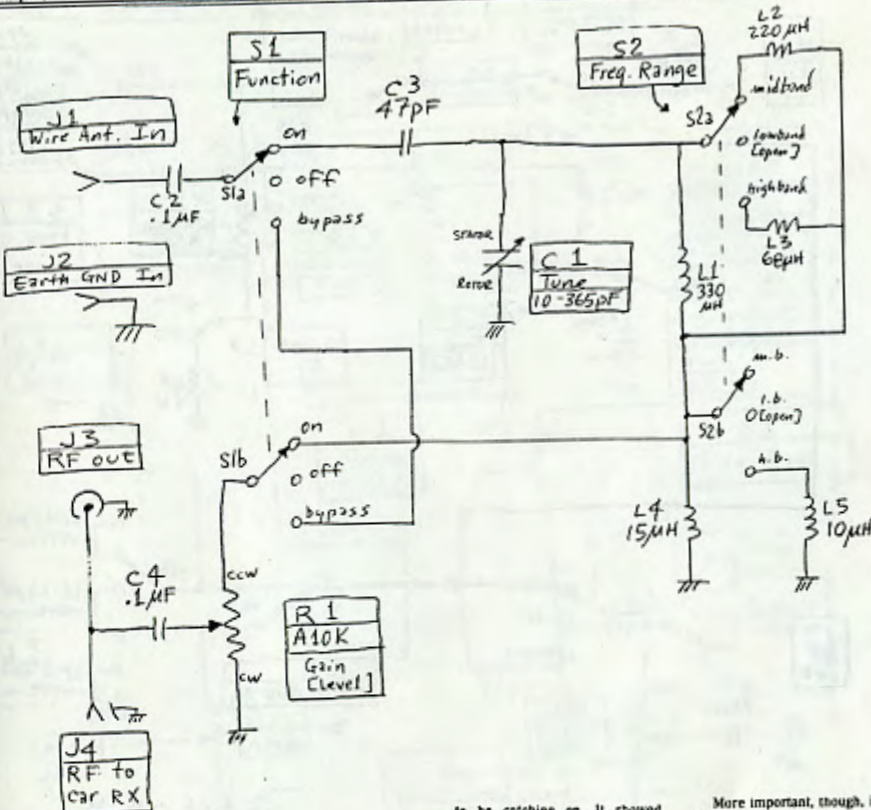

Radio Winners And Losers

There was a lot riding on Arbitron's just-released fall radio ratings. At the very least, the two groups waiting for FCC approval to assume ownership of KWK (AM and FM) and KSHE undoubtedly were looking for some indication of whether the present formats were viable. And everyone who follows the business was wondering whether KHTR could continue its remarkable performance.

Here, then, the winners and losers in the radio ratings derby:

**WINNERS:**

- KEZK pulled 8.1 percent of the overall listening audience, a number that general manager Matt Mills says is the highest in the station's history.
- KEZK's format is now mixing vocal numbers by real singers in with the elevator music, and the combination seems to have been embraced by female listeners in record numbers. The station's strongest time period is weekdays, from 10 a.m. to 3 p.m., when it is the dominant station with adults.
- KSHE returned to its first-place position with young men, and in the process may have saved its album-oriented-rock format

from extinction. The station was especially strong at night.

- KYKY turned around a sinking trend that probably would have meant a format change from adult-contemporary if it had continued. As it is, KYKY made a very strong showing among men, doubling and tripling its audience in some age categories and time periods. Yet at the same time, it lost female listeners, which puts the station in the position of having to change its sales pitch to advertisers.
- KWK (AM and FM) also reversed a ratings slide that had been brought on by virtually no spending on promotions while KHTR got a foothold with a hotter sound and heavy spending. While showing across the board improvement, the bulk of KWK's improved numbers seems to have come from teens tired of KHTR. Even these better numbers, however, may not convince its soon-to-be owners, Robinson Broadcasting, that there's enough support in St. Louis to sustain both KWKs, KHTR and KSHE, all of which appeal to similar audiences.
- KCFM's format of hit vocals from the last five decades appears

to be catching on. It showed distinct increases in almost all time/age/sex categories, especially morning drive-time, although the absolute size of the audience remains very small by comparison with its competitors. For example, among women aged 25-54 in morning drive time, about 2,700 were listening to KCFM during an average quarter hour, up from last spring. The leader in the category, KMOX, was down from previous showings, but still had an average of 33,000 listeners in the category.

- WIL-AM posted modest gains at best, but any improvement by AM music stations these days must be considered a notable achievement. While far from the audience levels of better days, the station's morning male audience seems to have staged a comeback, perhaps a function of the return of Wilkie to on-air duty in St. Louis. Tragically, Wilkie — Robert Wilkinson — was killed in an auto accident Monday.
- LOSERS:**
- KHTR seems to have peaked. The station lost listeners and share of audience in almost every time period and age/sex category. Promotional spending was off, which undoubtedly contributed to the station's showing.

More important, though, is the hi-radio format's tendency to wear listeners out over time. The only way to keep burn-outs to a minimum is to keep the music fresh while making sure the station stays the place to hear all the hits.

In addition, KHTR's on-air personalities have been popping up lately in various menial capacities on sister station KMOX, a move that cannot help but weaken KHTR's esprit de corps. And as popular as the "Hot Hit Video" TV show has been for Channel 4, it doesn't seem to have helped KHTR much.

- Speaking of KMOX, this was anything but a good rating book for the station. Compared with its performance a year ago, the station lost listeners in virtually all time periods. Some of that can be attributed to 1982's baseball Cardinals, whose world championship helps inflate the station's numbers above normal levels.
- KSD (AM and FM) also lost listeners, compared with the last rating period. The AM country station's problems were far more pronounced than the FM's.

The stations' bright spot was KSD-FM's morning drive-time, which posted gains in important male and female categories.

BY LOUIS POST VIA RICH EDDIE



16 **FIGURE 6**

**TBPPT**

Design Band 1500-6200 KHz

Tropical Bands Passive Parallel Tuner

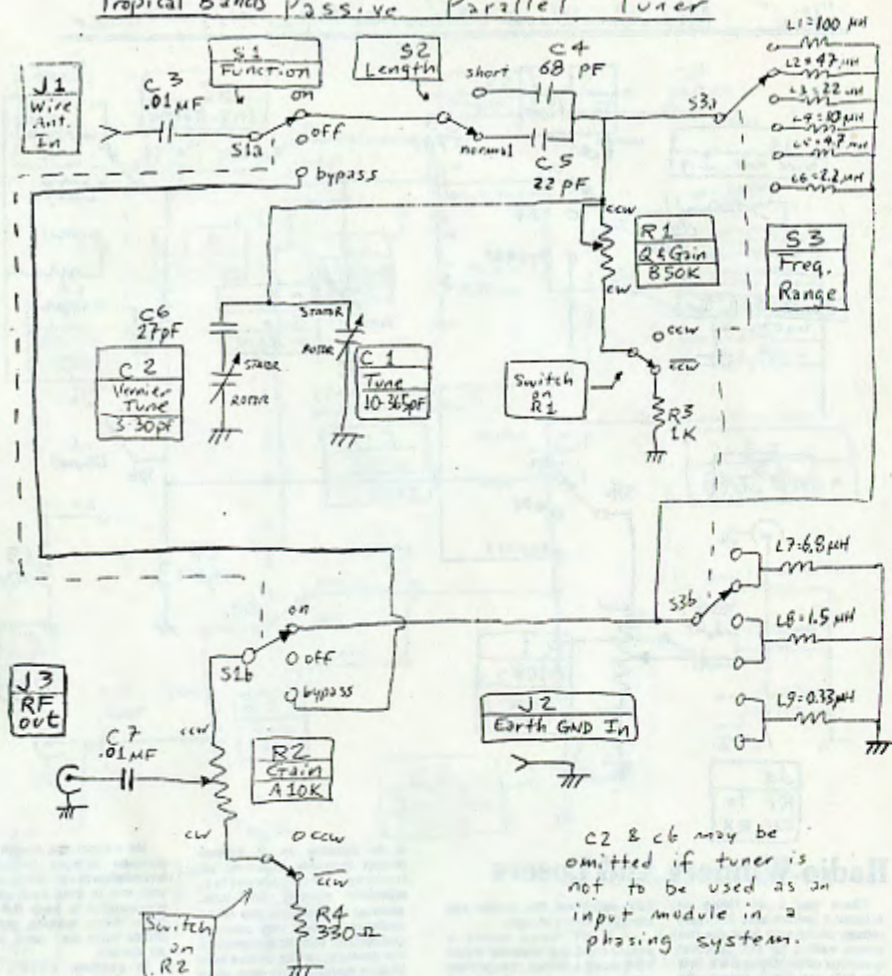
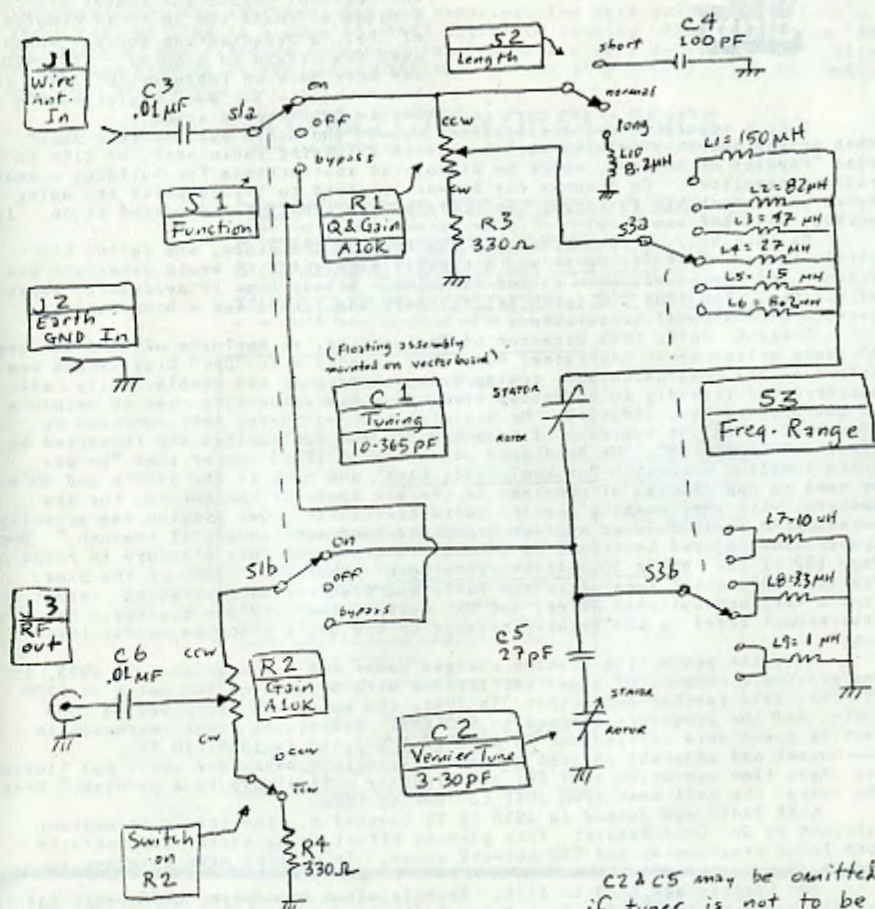

**FIGURE 7**

**TBPST**

Design Band 1500-6200 KHz

Tropical Bands Passive Series Tuner



500 Watts  
710 Kcys.

66 COMM BLDG SEATTLE, WASH.

**"THE QUEEN CITY STATION"**

We are pleased to acknowledge and verify your reception of the  
*Fate Hawk* Program at 10:00 P.M. S.T. on Feb. 1st, 1986.

**K-I-R-O**

This is an official verification of Cuban Radio Commercial Station

500 WATTS **CMQ** 640 KILOCYCLES

ADVERTISER PUBLISHING CO. LTD  
HONOLULU HAWAII  
**KGU**  
250 Kilocycles  
250 Watts  
"Hawaii's Adventure" Hawaii's Oldest Daily Magazine

FARGO (AP) - An amateur radio operator who was stranded with his wife and two children on a highway took inventory of other marooned motorists and transmitted reports to a radio station until his car ran out of fuel.

Gary Woodbury, Barney, left Fargo for home about 5 p.m. Saturday and became stuck two hours later in a winter storm on south-bound Interstate 29 after driving about 25 miles, he said.

"It was as far as we could go," he said. "We couldn't see anything."

Using repeater radio facilities in Fargo, he patched into a telephone circuit and called KFGO Radio in Fargo from his car, he said.

"Then I got out of the car and took inventory of who was out there," he said. "I got the names of all the people out there and gave

them to the radio station. They put the names out over the air."

Seven other vehicles with about 21 people were stranded nearby, he said.

Woodbury kept sending updated reports to the radio station until his car ran out of fuel about 4 a.m. Sunday, he said.

Other cars stranded nearby also began running out of fuel before help arrived about 8:30 a.m. and their occupants moved from car to car, huddling with fellow travelers to keep warm, he said.

"Everybody made it through the night and then when help came, it all came at once," he said. "Two Richland County deputy sheriffs and two snowplows came out of Fargo at the same time."

C2 & C5 may be omitted if tuner is not to be used as an input module in a phasing system.

Bismarck Tribune  
February 7, 1984



TONY FITZHERBERT  
356 JACKMAN AVENUE  
FAIRFIELD, CT 06430



CKNX - 920 KHz

Out on the flat agricultural expanse of Western Ontario, swept by howling winter storms, and blessed by bountiful crops in the late summer, in the regional population center of Wingham is found the AM-FM-TV complex of CKNX, a broadcasting success which owes its origin to a hobby. CKNX-920 was born back on February 20, 1926, in the rear of W.T. "Doc" Cruickshank's little Main Street store.

Doc, a popular local businessman, owned "The Radio and Electric Shop". When he was not busy talking with customers or fixing radio sets, he like to read "Popular Mechanics", where he discovered instructions for building a small radio transmitter. On a snowy day he was inspired to try to build it, using spare parts from his workshop. He finished his creation and turned it on. It worked, and CKNX was born!

He then built a tiny studio in the back of the store, and called his little station "JOKE" - as it was a novelty with which he would entertain his friends and customers, when he had the time. Nobody took it seriously, least of all Doc. The idea did catch on, as there was a need for a broadcasting service with a local orientation.

Scott C. Reid, CKNX Director of Engineering, an employee of CKNX for over 45 years writes about his former boss "Our founder W.T. "Doc" Cruickshank was indeed a very remarkable man, coming from a very poor and humble family, mild mannered and friendly to everybody even after his astounding rise to eminence in the broadcasting industry. He was, for the most part, self educated in electronics and the business of broadcasting and was admired and respected by all in the industry". Mr Reid also notes in a 6-17-83 letter that "We are quite familiar with the National Radio Club and back in the 1930's and 40's we used to run special DX programs in the wee hours of the morning for its members, with very amazing results quite frequently. Our station was actually established in 1926 as an amateur broadcast band non-commercial venture." Doc Cruickshank enjoyed hearing from DX'ers. Evidence of this pleasure is found on Page 122 of the NRC's 50th Anniversary Book, where, in 1930, at the time, Station IOBP, still located in the Radio and Electric Shop verified report from a very accomplished DX'er, and NRC member, the late Joe Brauner - Mr. Cruickshank added to the printed message on the QSL a gracious handwritten note.

Over the years, the station changed power and frequencies. In 1933, it was granted a commercial broadcast license with a power of 100 watts on 1200 KHz Mr. Reid further notes that "In 1941, the power was increased to 1000 watts, and the frequency changed to 920 KHz. Subsequent power increases in daytime power were carried out in 1959 (2.5 Kw) and in 1968 (10 Kw). Co-channel and adjacent channel station allocations have (and still do) limited our night time operation to 1 Kw, and probably will always be a problem." Over the years, the call went from JOKE to IOBP to CKNX.

CKNX Radio was joined in 1956 by TV Channel 8 - the result of another interest by Doc Cruickshank. This pioneer effort today serves Wingham with both local programming and CBC network shows. It's local news coverage is superb.

Doc Cruickshank died in 1971. Shortly after his death, CKNX Radio and TV was purchased by the London Free Press Publishing Company, owners of CPPL AM-FM-TV in London, Ontario. The operation of the stations was left to the nucleus of the management personnel hired by Doc Cruickshank.

In May, 1977, CKNX-FM joined with CKNX family. FM-102 today features contemporary music and extensive regional news coverage.

CKNX broadcasts a country music format. In early days, it was known as the "Voice of Community Service". "The Ontario Farm Station", and "Home Town Radio". The country format is augmented by extensive local news coverage, earning the station the role of an essential, and enjoyable part of the life of the 3000 Wingham residents, plus hundreds of scattered rural denizens in the farming hamlets scattered up and down the eastern shore of Lake Huron.

In March, 1962, a fire destroyed both the radio and TV facilities. After a brief silent period, CKNX, returned to the air from temporary facilities.

Today a modern broadcast complex serves the agricultural communities of Western Ontario. The transmitter facilities are located on Highway 4, 3 1/2 miles South of Wingham. The 10,000 watt day pattern emits from three 220 foot high towers in line East to West, and the 1000 watt night pattern originates from two 220 foot towers, in line North to South. The night signal has been heard - and verified in both Windsor and Fairfield, Connecticut.

19 Today CKNX-920 is both a tribute to the imagination and creativity of its founder, Doc Cruickshank, and an integral part of the town of Wingham, as it informs and entertains its listeners, with up to the minute news, and fine country music.

The Editor would like to thank Scott C. Reid, CKNX Director of Engineering and friend of the National Radio Club, for his help in sharing both information on the stations, and his memories, for this profile. He took a great deal of time in a June 17, 1983 letter to develop this information, and, in addition, acknowledges reception reports with a very detailed verification. It is also fitting to recognize CKNX as a friend of the Club - and the hobby for over 50 years.

## A COLLECTION OF CLASSICS

RARE and UNUSUAL QSL's

compiled by JERRY STARR

The Verification Section was assigned to me since I am the fortunate trustee of two of the largest verification collections ever amassed, those of the late Joe Brauner and Norm Maguire. In addition, members were asked to submit copies of their prized verifs for possible inclusion in this section. The decision of what to include was difficult indeed, given the few pages here and the 10,000-plus verifications on hand. Unfortunately some of those submitted had to be left out simply because the copy quality was not sufficient for reproduction. Since there are hundreds of other rare and interesting QSL's that could not be included, I will be sending a large file to the publishers of DX News and hopefully we will be able to initiate a new section featuring vintage verifs on a regular basis in the magazine.

### AMATEUR BROADCASTING STATION 10 B.P.

25 WATTS 1000 HERTZ CYCLES

THE RADIO & ELECTRIC SHOP

WINGHAM, ONT.

Wishes to thank you for your communication and hereby verifies your reception of our program of Dx Dec 1978 as the selections mentioned comply with our log. 10B.P. is maintained by radio fans, and does no advertising, the station is entirely home made. Wingham is a town of 2400 population and is the only town in Canada having a broadcasting station. Our operating hours are given on the back page.

May we have the pleasure of hearing from you again?

Yours truly,

W. Brauner  
recommends Mr. Brauner for giving report on reception. Just what I wanted.

Left: In radio's infancy all stations were amateurs. By 1930 one still was in Canada. The "only town" statement refers to "town" as opposed to "city".

## CONTESTS

ROBERT KRAMER  
6416 N. RICHMOND  
CHICAGO, IL 60645

### CONTEST STANDINGS as of 2/12/84

|                    | A   | B  | C  | D | E | F | G | H | I  |
|--------------------|-----|----|----|---|---|---|---|---|----|
| George Sherman, MN | 431 | 49 | 44 | 0 | 0 | 0 | 8 | 5 | -- |
| Bill Hardy, WA     | 258 | 31 | 0  | 0 | 0 | 0 | 6 | 7 | 07 |
| Jim Renfrew, NY    | 251 | 42 | 0  | 0 | 0 | 0 | 7 | 3 | 04 |
| Paul Stephan, CT   | 250 | 32 | 0  | 0 | 0 | 0 | 7 | 4 | 03 |
| Nolan Stephany, NY | 245 | 37 | 0  | 0 | 0 | 0 | 7 | 3 | 03 |
| Nancy Hardy, WA    | 233 | 31 | 0  | 0 | 0 | 0 | 5 | 7 | 07 |
| Arnie Littek, ON   | 170 | 37 | 0  | 0 | 0 | 0 | 4 | 3 | 03 |
| Karl Forth, IL     | 89  | 39 | 0  | 0 | 0 | 0 | 2 | 0 | -- |
| Bruce Conti, RI    | 61  | 38 | 0  | 0 | 0 | 0 | 0 | 2 | 03 |
| Mike Hogan, IL     | 46  | 21 | 0  | 0 | 0 | 0 | 1 | 0 | -- |

### NONCONTESTANT

Me 550 52 46 42 0 0 4 5 --

See last report to determine the meaning of the symbols.

# VERIFICATION GAME

Wayne Heinen  
1642-C S. Idalia Cir.  
Aurora, CO 80017

PLEASE PUT ALL CONTRIBUTIONS TO THIS COLUMN IN FREQUENCY ORDER - THANKS ALL !!

|      |         |   |       |      |        |                         |    |
|------|---------|---|-------|------|--------|-------------------------|----|
| 540  | CJSB1u  | Zella Dawkins Coordin-<br>ator of BC Services | JM    | 1220 | KZEE1b | Dave Solonson M         | JH |
|      | WL1X1   | John Bennett CE                               | PS    |      | WSLM1m | Don H Martin CE         | JH |
| 550  | KFRM1   | Abram Burnett                                 | JH    | 1240 | WFTN1  | Barry Simmons GM        | JH |
| 570  | WNAX1   | Jerry Oster OpM                               | JH    | 1260 | KG111b | Gloria Muraszko         | PO |
| 590  | WOW1    | Harry C. Stutzman CE                          | JH    | 1270 | KIML1  | Harvey P.D. Hetland COP | JH |
|      | WRTH1   | James E. White CE                             | JH    | 1280 | WANS1  | Richard Luth CE         | JH |
| 600  | WCAOq   | Erich Stummingal ESu                          | JM    |      | WSAT1  | Jim Graham CE           | KG |
| 610  | KRKEq   | Robert Leech CE                               | JH    |      | WHVRq  | E.L. Sherman VP/CE      | JM |
| 640  | WMSO1m  | Kaye DeAtley SalesM                           | KG    |      | WMCp1  | Daryl Hancock CE        | JM |
| 690  | CBUq    | D.J. Harner                                   | WH    | 1290 | WSBL1  | Tom Williford PD        | BP |
| 710  | CJRN1   | Wm McDougall CE                               | HH    |      | WHYm   | Harry Hyman GM          | JM |
| 740  | WBAMq   | Thomas Jones III CE                           | PS    | 1300 | WXPXr  | Paul Wensko E           | KG |
|      | WGSN1   | Marc Sophos ACE                               | PS    |      | 1      | Neil J. Rodino GM       | DS |
| 747  | JOIBq   | u/u   | WH    |      | WAVZ1  | Bill Elliot CE          | PO |
| 750  | WHEBq   | Tony Vaccaro CE                               | PS    | 1310 | WNSY1  | Will Bevis CE           | HH |
| 780  | WABS1m  | Steve Cross                                   | KG    |      | 1      | Herman Wood CE          | HH |
| 790  | KKBQ1   | Jon Bennett CE                                | JH    | 1320 | WQIK1b | Bill Mize GM            | KG |
|      | WAEB1   | Wayne Frederick ACE                           | PS    |      | KWHNq  | Ken Blevins CE          | JH |
| 800  | WLADq   | u/u CE  | PS    | 1330 | KWL01m | Mike Soar CE            | JH |
|      | CHAB1b  | Mike Soar CE                                  | JH    | 1340 | WROD1  | Sheila A. Mullett OFM   | JM |
| 810  | KAPE1   | Gary Kabrick CE                               | JH    | 1350 | WROD1  | Troy Pennington         | JM |
| 820  | WAITq   | Dave Dybas CE                                 | PO    |      | KRNTq  | Bill Swenbergen CE      | JM |
| 830  | WCCOq   | u/u   | PS    |      | WLOVb  | but no verie!           | JM |
| 850  | WDEL    | u/u CE  | PS    |      | WANCL  | Lester Seidenberg CE    | JM |
| 890  | WHNC1   | Terry Freitag CE                              | PO    |      | WBBR1m | Jonathan Timko PD       | JM |
| 900  | KHOZ1   | Mary Fleenor PD                               | JH    |      | WRKMm  | Reggie L Honey P        | JM |
| 910  | KPOFq   | R.B.Dallenbach GM                             | JH    |      | WNVA1  | John R DuVal IV PD      | JM |
|      | KAMD1   | Bill Sdearly SalesM                           | JH    |      | WN1Km  | Clif Mills COP          | PO |
| 930  | WFMD1m  | John Fieseler COP                             | JM    | 1360 | KSCJq  | u/u CE                  | JH |
| 940  | WECO1m  | Carl Stump P                                  | WH/JM | 1370 | WGOHr  | u/u                     | JM |
| 950  | KRRP1b  | Ray Arthur GM                                 | JH    |      | KDTH1m | Marc Karrmann CE        | JH |
|      | KJRC1   | Kathy Banning Secy                            | JH    |      | KAWW1  | Charlet E Howell M      | BP |
|      | WQBE1   | Lester Lovejoy CE                             | HH    |      | WNYD1  | Lee Blair GM            | JM |
|      | WPEN1fm | Charles Fritz                                 | PO    | 1380 | WTOB1  | Tom Findley             | KG |
| 960  | WPCN1   | Janet Buynak SM                               | PO    |      | WBBX1  | Mark Ericson PD         | PO |
|      | WSBYq   | Bernie Spanks CE                              | KG    | 1390 | WEOK1m | Bud Williamson ACE      | PO |
|      | WNGR1   | Bill Shipp AstM                               | KG    |      | KMRY1  | John G Enoch P          | JH |
| 980  | WTRYf   | David Abdoe CE                                | PO    | 1400 | WAMQ1  | Neil Hart GM            | DS |
|      | KMBZ1m  | Dale Wolf ESu                                 | BP    | 1410 | WDOE1m | Dan Warren PD           | JM |
|      | KFWB1m  | Richard Rudman EngM                           | JH    |      | WIZM1  | Gene Vehling CE         | JH |
| 1000 | WXTN1   | Fanny Cochran EngM                            | JH    |      | KCLO1  | Dave Barnett CE         | JH |
|      | KKIM1b  | Joe Muench OpM                                | BP    | 1420 | WVJS1b | Michael Flenning DoE    | JH |
| 1010 | KBBW1   | Randall B Tighe CE                            | JH    |      | WINI1  | Dale Adkins TD          | JH |
|      | KXEN1m  | Bernie Harville Jr GM                         | JH    |      | WCEDq  | Larry Fisher CE         | DS |
|      | KIND1   | Nelson Rupard                                 | JH    | 1430 | KXOW1  | Bob Henderick SalesM    | BP |
| 1030 | KCTA1   | Nathan Lindsey DoE                            | JH    |      | KKOZ1  | Bob Moore DJ            | BP |
| 1050 | WHG11m  | J Christopher Dixon                           | PD    |      | KEES1  | D. Johnson TRFD         | BP |
|      | WJSJ1   | Chris Roberts PD                              | JM    |      | WDEX1  | Paul Mapes E            | BP |
|      | WGAT1m  | Mike Long COP                                 | JM    |      | WIREq  | Bob Watkins GM          | BP |
|      | WPAG1   | Patrick Seeneey ACOp                          | JM    |      | WZYXr  | u/u                     | JM |
| 1060 | WHFBq   | Steven R Messer CE                            | KG    | 1440 | WNYG1  | Joe Brewer VP           | JM |
|      | KLSM1   | Bill Atwell PD                                | BP    |      | WNYG1  | Bob Maddox PD           | PS |
| 1070 | WKOK1   | John Keller Jr VP/ENG                         | JM    | 1450 | WIINq  | Marvin Pincus CE        | KG |
|      | WINA1   | Pat Wilson PD                                 | JM    |      | WNWZ1  | Tyrone Dickerson P      | KG |
|      | CBAlq   | Sylvia Roy                                    | PO    | 1460 | WNCN1m | Jack Kerman Nx          | KG |
| 1080 | WYCH1   | Sam F Cooper VP/GM                            | KG    |      | WEZJ1  | Paul Estes GM           | BP |
| 1110 | KTEK1b  | Virginia Eernisse BusM                        | KG    |      | KRNY1  | Richard Roessler GM     | WH |
|      | WHIMr   | u/u CE  | PO    |      | KSOL   | Timothy Boots CE        | JH |
| 1120 | WIZY1   | Al Parker OpM                                 | KG    |      | WWS    | Sue Bahner              | JM |
|      | WNYS1b  | Ray St. James PD                              | KG    | 1470 | WRGA   | Michael McDougald P     | JM |
| 1130 | KYOO1   | u/u   | BP    |      | KUTYr  | P Dale Ware VP/GM       | WH |
|      | WSJPL   | Greg DeLaney                                  | BP    |      | KWRD1  | Mrs Helen Dean GM       | WH |
|      | WAMG1   | Lee Raines GM                                 | JM    |      | WSRO1  | John Swiridale          | PO |
| 1150 | KNED1   | Lee Anderson COP                              | JH    |      | 1      | Tom McAuliffe           | PO |
|      | KSAL1   | D.A. Enghardt                                 | JH    | 1480 | KBEA1  | Robert Ingram           | BP |
| 1170 | WAMBq   | u/u CE  | JM    |      | KLEO1  | Terry Michaels Op       | JH |
|      | WJCC1   | Steven J Callahan CE                          | JM    |      | WAME1  | Fred Roberts CE         | JM |
| 1190 | WHIYf   | Rice Towry                                    | KG    |      | WSAYfm | Tom Crockett CE         | JM |
|      | WL1B1   | Paul Sanchez CE                               | PO    | 1510 | KDVE1  | Dan Hubbard GM          | JH |
| 1210 | KREW1b  | u/u M   | WH    |      | WAUK1m | Rick Gundrum PD         | JM |
| 1220 | KLCOL   | Betty Orainer APD                             | BP    | 1520 | WKZQ1  | Bill Files CE           | KG |
|      | KZYM1   | Don Zimmer GM                                 | KG    | 1530 | KNBO1  | Will Shell DJ           | JH |
|      |         |   |       |      | KECK1m | R.M. Simonsen CE        | JH |
|      |         |   |       |      | KCLR1m | Robert Martinez M       | BP |

|      |        |                   |        |      |        |                    |    |
|------|--------|-------------------|--------|------|--------|--------------------|----|
| 1540 | WSWG1  | Charles White OpM | JH     | 1580 | KNIX   | Eric Schecter ACE  | JH |
|      | KXELq  | John A Bauer      | JH     |      | WBG1   | Ken Courtright GM  | JM |
| 1550 | KKJO1  | Bruce Allen PD    | JH     |      | WAMB1  | Joseph Simon PD    | JM |
|      | KHB1   | Gary Foxe OpM     | JH     |      | WLMQ   | u/u VP             | PS |
|      | WNTN1  | Robert Wolf CE    | JM     |      | WVKO1  | John Marocchi      | PS |
|      | WVAB1m | Steven Soldingr   | OJM/PS | 1590 | WMIM1  | David Donlin P/GM  | PS |
|      | 1m     | Ed French P       | JM     |      | KQYK   | u/u                | BP |
|      | WWW1   | Tony Edmondson DJ | HH     |      | KHEN1  | Tom Keith Nx D     | JH |
| 1560 | WSD1   | Don Kern          | HH     | 1600 | KOGLT  | Jim Baker PD       | JH |
|      | KDDA1b | Allan Eastham GM  | JH     |      | KMD01  | Tim McKenney M     | JH |
| 1570 | WOKZ1m | Walter Brink      | JM     |      | WRBN1m | Don Jones CE       | JM |
|      | KMYZ1  | Vicky Shaw OffM   | BP     |      | WIXYp  | Mike Williamson TD | JM |
|      | KLOV1  | Andy Loomis       | JH     |      | WNSTm  | Tom O'Toole MxD    | JM |
| 1580 | KZIAL  | u/u               | JH     |      |        |                    |    |

Contributors:  
WELCOME! to new Contributors!

John Herman - OK JH  
Paul Stephan - CT PS  
Patrick O'Connor - NH PO

Thanks to my continuing supporters!

Dave Schmidt - DE DS  
Kermit Geary - PA KG  
Hank Holbrook - MD HH  
Bill Prater - MO BP  
John Malicky - PA JM

WH is the typists

If one combines the abbreviations you can obtain the most used titles as found on most verifications. Of course as soon as this hits print ten more will show up. Try to keep list for reference. WH

LETTER BEHIND THE NAMES MEANS:

A - Announcer (if used alone)  
A - Assistant (when combined)  
C - Chief  
D - Director  
E - Engineer  
G - General  
M - Manager  
O - Owner  
P - President (alone)  
- Program (combined)  
T - Technician (if used alone)  
- Technical (when combined)

Doubles & Triples etc

Eng - Engineering  
Bus - Business  
DJ - Disc Jockey  
Mx - Music  
Nx - News  
o - office  
OF - Office  
Op - Operator (alone)  
- Operation (C)  
Secy - Secretary  
SlS - Sales  
Su - Supervisor  
Sx - Sports  
Trf - Traffic  
VP - Vice President

The First  
**AM Stereo**  
in Iowa

GREAT COUNTRY!

**KSO**  
Radio



JOAN ORR'S  
CAPE ACOUSTICS

IS ON THE AIR  
SAT. & SUN. - 10 A.M. - 2:00 P.M.

**WVLC** AM 1370  
"The Voice of the Lower Cape"



A unique blend of acoustic music drawing from many genres like:  
James Taylor, Van Morrison  
Emmylou Harris, David Grisman  
Joan Armatrading, Bonnie Raitt

Sponsored in part by:

Mean Song Cafe - Brewster Golf Course  
Cave Cyle - Orleans  
The Berkey Neck Lounge - E. Orleans  
Fisherman's Coffee House - Woods Hole  
Woods Hole - Orleans  
Woods Hole - Orleans  
Foreign Affairs Auto - Orleans  
Pete's Larkin Guitar Studio - Yarmouthport  
Digital Hi-Fi - Danversport  
Hudson Riding Stable & Bicycle Shop - Race Point, Freetown  
Brewster Inn & Chandler House - Brewster  
1807 House - Freetown  
DeCar Classics - Brewster

### NEEDED RADIO INVENTIONS by Irving J. Saxl, Ph.D.

With the new year upon us, and based upon the background of a great array of new devices and methods which are made possible by the advanced radio techniques of the past year, dreams surge onward toward new possibilities which some luck amateur (experimenter) may one day attain. RADIO NEWS often receives inquiries from men who believe they have found new things, from persons who feel that there is a definite need for certain inventions, and last but not least, from industries which are looking forward to new designs that will increase the range of radio and various electronic applications and will create profitable enterprises.

#### CAN YOU INVENT THESE?

1. An entirely new and practical low-priced television system.
2. A combination of known television ideas into a new and practical low-priced television system.
3. A portable pocket-size transmitter and receiver with self-contained power supply capable of working a distance of 25 miles.
4. A perfect system of eliminating static in radio reception that can be attached to any set.
5. An automatic volume-control system that entirely eliminates fading and that would bring in all stations, local and distant, with exactly the same volume.

Some you win, some you lose, and some fall in the same category as finding a cure for the common cold....

## Boy Shoots Xmtr

by A. Adam Glenn

Norfolk VA... A 16-year-old male recently shot up the new transmitter site of WTAR/WTLY AM-FM with a rifle, causing over \$7,000 in damages.

He was arrested by Hampton, VA police several days later, and has since pleaded guilty to charges of breaking and entering, and property destruction.

The suspect, whose name is being withheld because of his age, is now in his parents' custody, according to Police Lieutenant B.G. Pierce.

Police are also working on the probability that another person was involved in the crime, although no one has yet been charged, Pierce said.

The apparently motiveless act occurred late afternoon 29 November at the site outside Norfolk, which was being prepared for full time use in early January.

The station suffered damage to remote control gear, processing equipment, oscilloscopes, and S1Ls/TSLs at the site, according to WTAR CE John Zaub.

"There were over 30 rounds fired," Zaub said. "There was at least one slug in each piece of gear, and the remote control unit had 10 shots fired into it."

He took out the oscilloscope to use for target practice," Zaub added, "and also cut every wire at the site, including the phone lines."

The youth gained entrance to the transmitter building, described by Zaub as "cement block with a solid steel door," by prying open the louvers which ventilate the transmitter's emergency generator.

The station still intends to begin using the site full-time in late January, but hopes to insure future security there with the addition of an alarm system, sensors on the doors and bars on the louvered opening.

Despite these measures, Zaub worried that "when you're out in the boonies, there's just not very much you can do."

"But any radio station is really vulnerable," he said. *VIA FAX ONLY*

**whnd 56 am**

6305 Vineyard Drive, Monroe, MI 48161



**WNAX-570**

YANKTON, SO. DAKOTA 57078

**5-STATE RADIO**



Your bids go to the Address at the right and NOT TO NRC HQ. Orders for direct sale items and for All bids should be sent to:

SAM BARTO  
47 PROSPECT PLACE  
BRISTOL, CT 06010

MAKE YOUR CHECKS & MONEY ORDERS OUT TO "HAP"

This page brought to you as a Public Service of the NRC

**HAP DIRECT SALE ITEMS:** The following stickers/decals are available for \$.25 each or any 5 for \$1.00: RBI (large) (small), Die Lutherische Stunde, CFRB, Radio Bare, Radio Superstar, KVDB, CFCR, CKUA, CFCN, CFCN, CKRD, CKGY, Radio Monte Carlo, Radio 210, WEMP, Disco-99, WBWA, EMR, KPLU, WQXR Amateur Radio, Radio Reporter, WJRG, WBW, Radio Teens, RCI, RFI (blue) (red), 6KY, Radio Vatican (small) (semi-cir) (square), WCBW, KCFM, ANARC (small), CFTI, RNE, WDR (rock) (small), Radio 270, KFQC, 55-Country, Radio Derby, Rete Quattro, Polakie Radio, ORF, Radio Budapest, Metro Radio, KBOI, KPNN, KKKD, WEZX, WCFI, WLUP, KROY, ELGL, KLOS, WINS and ESPN.

**HAP BID ITEMS:** ITEM #348: Radio Veritas (Philippines) 1984 staff calendar, m/c-very nice! #349: Netherlands World Broadcasting - a feature publication by R.D. Haslach. This book contains @ 110 pages on the history of radio in Holland with dozens of old and rare photographs! #350: Radio Obrera (Spain) sticker (3.5" cir) m/c. #351: 4XD (New Zealand) sticker (1.5x7.5") blue, white-one of the oldest stations in the world!! #352: RAIM (Hawaii) sticker (4x7") blue, white. #353: Radio Vatican 1984 calendar in English, m/c-very nice. #354: Radio Vatican 1984 calendar in French. #355: Radio Vatican 1984 calendar in German. #356: Radio Vatican 1984 calendar in Polish. #357: Radio Vatican 1984 calendar in Italian. #358: Europe #1 (FRG) sticker (2.5x7.5") blue, B&W. #359: HCJB-FM (Ecuador) sticker (3x8") B&W. #360: Radio Forth (Scotland) decal (5x6") m/c. #361: Radio 3 Stuttgart (FRG) sticker (5x5") m/c-nice! #362: Deutschlandfunk (FRG) sticker (5x6") m/c. #363: Radio Cayman sticker (3.5x12") orange, B&W-rare! #364: Radio Nottingham (UK) decal (3x7.5") m/c. #365: Radio Munich (FRG) decal (4x6") blue, white. #366: Radio Tirol (Italy) sticker (3.5x4") red, B&W. #367: Radio Libertaire (France) sticker (3.5x4") B&W-nice! #368: CFRB staff photo card (3.5x5.5") B&W. #369: KNUI (Hawaii) sticker (4x7.5") red, white. #370: WYFR sticker (4x6") yellow, B&W. #371: 4GG (Australia) sticker (6.5" cir) m/c-beauty! #372: KOME large 1984 wall calendar (13"x3") m/c-beautiful!! #373: Radio Mexico sticker (3x4.5") m/c. #374: Radio Nacional do Brasil sticker (3.5" cir) m/c-nice! #375: Peter Flowers Radio (Italy) sticker (3x6.5") m/c. #376: VOA sticker (3" cir) red, white, blue. #377: Radio 210 (UK) decal (4.5" cir) m/c. #378: Radio Italia metallic sticker (4.5" cir) m/c-beautiful! #379: Bayerischer Rundfunk (FRG) sticker (4" cir) blue, B&W. #380: Italia-TV sticker (3.5" cir) m/c. #381: CFOX sticker (4.5" cir) m/c-beauty! #382: LBC (Italy) sticker (3x5") white, purple. #383: Radio Vatican QSL card (4x6") m/c. #384: Radio Mediterranean (Malta) sticker (4" cir) red, white, blue. #385: Radio Luna Perugia (Italy) sticker (3x4.5") blue, B&W. #386: Radio Koper-Capodistria (Yugoslavia) sticker (2.5x3") m/c-rare! #387: Peter Flowers Radio sticker (2x19") white, green-nice! #388: 4FFF (New Zealand) sticker (3x6") red, white. #389: Red Rose Radio (UK) decal (5x5") m/c. #390: Radio Veritas sticker (3x10") yellow, B&W-rare! #391: Radio Japan 3 different QSL cards (4x6") m/c. #392: Voice of Asia (Taiwan) pin, m/c-beautiful!! #393: Radio Tirol Wundervoll (Italy) sticker (2.5x4") red, B&W. #394: Radio West (UK) pen, m/c-nice! #395: Voice of Tomorrow (US-Pirate) QSL card (3x5") B&W. #396: BBSI Radio (Italy) sticker (1x7") m/c. #397: World Scout Bureau QSL card (3.5x5") red, B&W. #398: RRI (DDR) cloth pennant (5x8") red, blue, white. #399: RRI (DDR) cloth pennant (6x10") m/c with Bear emblem. #400: REE (Spain) cloth pennant (5x9") m/c. #401: RAE (Argentina) paper pennant (5x8") m/c-nice! #402: Radio Nederland address book (2.5x3") red, gold. #403: Radio Nederland money pouch (3x3") B&W. #404: WVI (Virgin Islands) sticker (3x5") blue, white. #405: Radio Milano International poster (12x16") m/c-nice! #406: Radio 210 metal badge (1.5" cir) red, B&W. #407: Radio 210 pencil, red, gold. #408: Radio Nederland cloth pennant (4x6") m/c. #409: RRI (DDR) plastic litter bag (11x17") m/c. #410: Radio Banconara Sciu (Italy) metallic sticker (2x4.5") m/c-very nice! #411: Radio Veritas cloth pennant (3x5.5") blue, white. #412: Radio Veritas cloth pennant (4x8") m/c. #413: Radio Veritas cloth pennant (4x8") yellow, blue, white. #414: HRVC (Honduras) cloth 22nd Anniversary cloth pennant (6x11") blue, B&W. #415: Radio Korea double sided paper pennant (4x8.5") m/c-nice! #416: Radio Tampa-NSB (Japan) sticker silver, black-sharp! #417: Radio Clyde (Scotland) decal (2.5x23") red, white. #418: KTAC large m/c station poster. #419: Radio Sweden poster (12x16") m/c. #420: ANARC metal badge (1.5" cir) B&W-rare! #421: BBC-World Service (UK) metal badge (1.5" cir) red, white, blue. #422: WDR Radio (FRG) pen, blue, B&W. #423: RRI (DDR) stick pin, blue, white. #424: Radio Polonia stick pin, red, white, silver. #425: 6MFP (Australia) cloth sew-on arm patch, blue, white, orange-very nice! #426: South Coast Radio (Ireland) decal (6x6") red, B&W. #427: 4ZA (New Zealand) sticker "Kiwi Bird with Flag" (5" cir) m/c-beautiful!! Hope there is something here for you!

**ADDITIONAL DIRECT SALE ITEMS:** The following items are available at the quoted prices: WLPX, WMMR and WNET metal badges at \$.25 each; mini-B&W posters at \$.25 each from Radio London, Radio Nord, Voice of Syncon, Radio West, Radio Diana (car) (woman), Radio Caroline and Radio Fil Rose; RRI and Radio Feking book markers at \$.25 each; WMMR book covers at \$.25 each; metal "Antenna" badge at \$.25 each; RCI plastic station pennants at \$1.50 each; WMMR large litter bags at \$.50 each; RCI DJ photo card at \$.50 each; KIVI-TV plastic litter bag at \$.50 each. HAP THANKS: A very big thank you goes out to the following people who have made recent donations: Dave Platt, Edward Mitkus, Charles Fox, John Bryant, Don McCants, Joe Talbot, Josh Giffin, Arthur Cushman, Michael Tuggle, Mark Warner and Bill Matthews. Thank you... Sam. Almost forgot one of my good friends Don Moore down Honduras way.

**ADDRESS:** Please send your orders for direct sale items and your bids to Sam Barto, 47 Prospect Place, Bristol, CT, 06010 USA. Please try to keep a minimum order on direct sale items to at least \$3.00. Thank you... Sam.

**REQUEST:** We wish to make the 1984 ANARC Convention in Toronto the best ever. We desperately need any and all types of radio and TV station promotional items. These include stickers, decals, pens, pins, mugs, books, records, T-Shirts, etc. We are asking you, our supporters and friends, to help us out. Please contact your local stations to see what may be available. We will gratefully accept all donations... Sam.