

Windpower
for your hamshack

NOVEMBER 1978 / \$1.25

HAM RADIO HORIZONS

**BUILD A LOW COST
3-BAND BEAM**

**WILL ORR LOOKS AT
THE HAM BANDS**

**HOW TO USE
NOISE BRIDGE**

**LATEST FREQUENCY
ALLOCATION CHART**

40

PO



Easy to use

Drake accessories

designed with the user in mind

Drake 7077 Dynamic Desk Microphone



- Audio and level characteristics custom designed to match the transmit audio requirements of the Drake TR-7.
- Features both VOX and PTT operation without modification.
- Includes coil cord and plug wired for direct installation to the Drake TR-7.
- Style and color provide a beautiful match to the Drake 7-Line.
- Size 4.3"W x 5.8"D x 9.3"H (10.9 x 14.7 x 23.6 cm). Wt. 1 lb, 7 oz (650 g).

Drake 7077
High Impedance
Desk Microphone ... \$45.00

Drake "Dry" Dummy Loads —no oil required—

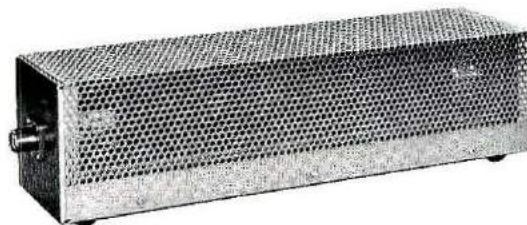

Drake
DL-1000



Drake
DL-300

Model 1551 Drake DL-1000

- 1000 watts for 30 seconds, with derating curve to 5 minutes. Designed to accept Drake FA-7 cooling fan for extended high power operation.
- VSWR of 1.5:1 max. 0-30 MHz.
- Provided with SO-239 coax connector, and rubber feet for desk or bench use.
- Size 14 x 3.6" (35.6 x 9.1 cm). Wt. 2 lbs (910 g)

Price \$39.95

Model 1550 Drake DL-300

- 300 watts for 30 seconds, with derating curve to 5 minutes.
- Built-in PL-259 coax connector for direct connection to rear of transceiver or transmitter—no jumper coax necessary.
- VSWR of 1.1:1 max. 0-30 MHz 1.5 max. 30-160 MHz.
- Ideal as bench test device for amateur or commercial hf and vhf gear.
- Small size fits conveniently in any field service tool box. 6.7 x 2.08" (17.0 x 5.3 cm). Wt. 11 oz (310 g)

Price \$19.95

To receive a FREE Drake Full Line Catalog, please send name and date of this publication to:

R. L. DRAKE COMPANY



DRAKE

540 Richard St., Miamisburg, Ohio 45342
Phone: (513) 866-2421 • Telex: 288-017

LONG'S 550 ANTENNA SPECIAL

CALL TOLL FREE

1-800-633-3410

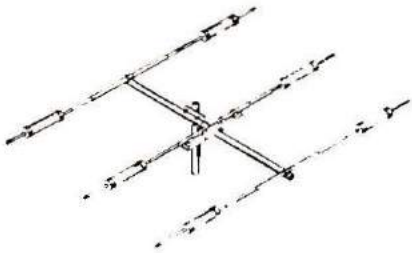
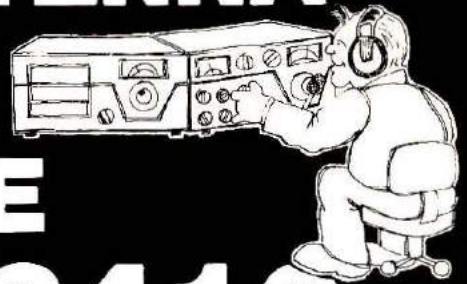

MOSLEY TA-33 Jr

3-element beam features: Gain 10.1 dB (over isotropic source). Front to back 20dB. 1 KW PEP SSB input. VSWR at resonance 1.5/1 or better. Longest element 26'8". Wind surface 4.0 sq. ft.

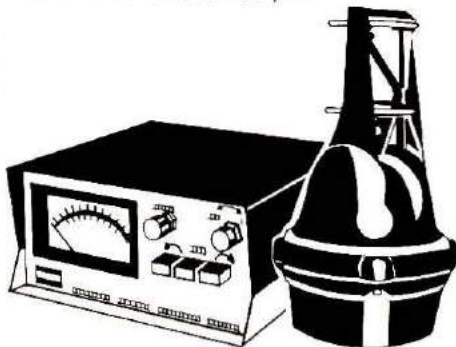

CDE CD-44 antenna rotor

Wind load capability 4.0 sq. ft. when mounted inside tower, 2.5 sq. ft. when mast mounted with supplied adapter. Includes control box and illuminated meter.

ROHN 25G 50 ft tower

Complete with four 10' sections, plus an 8' 25AG-3 3" OD top section. "Hot Dip" galvanized inside and out to resist corrosion better than any other tower.

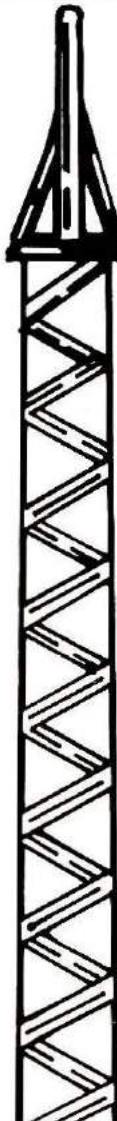

order now and save 151.55

Shipped freight prepaid anywhere in the continental USA!



YOUR COST
\$550

List Price 701.55

Special includes:

- 50 ft. ROHN tower with AS25G rotor plate List 304.60
- CDE CD-44 antenna rotor List 154.95
- 100 ft. RG 8/u foam coax List 25.00
- 100 ft. 8 conductor rotor cable List 20.00
- MOSLEY TA-33 Jr. 3-element beam .. List 197.00



Long's Electronics



MAIL ORDERS: P.O. BOX 11347 BIRMINGHAM, AL 35202 • STREET ADDRESS: 2808 7TH AVENUE SOUTH BIRMINGHAM, ALABAMA 35233

Remember, you can Call Toll Free: **1-800-633-3410** in the U.S.A. or call **1-800-292-8668** in Alabama for our low price quote. Store hours: 9:00 AM til 5:30 PM, Monday thru Friday.

THIS MONTH'S

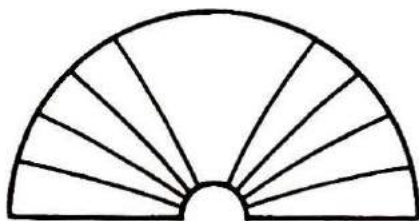

HORIZONS

Windpower For Your Hamshack

Most amateurs who use beam antennas are aware of the force the wind can exert on towers and hardware — sometimes with unhappy results. How many have thought about harnessing that power and putting it to work? Few locations are suited to using windpower on a full-time basis, but it can be a very useful supplement to the energy you get from the power company. WA1IAO tells you what to look for in a site, and how to build a wind-powered generator from common hardware.

What Can You Expect?

Bill Orr, a seasoned old timer, antenna experimenter, and DXer *par excellence* tells the beginner about the peculiarities, characteristics, and personalities of the various Amateur Radio bands. Modes, transmitter and antenna requirements, skip distances, and the amateurs who use them are all covered. From local "rag-chews" to the moon and back, and contacts via OSCAR, W6SAI's comments open a window on the wide, wide world of Amateur Radio.

Amateur Radio in the African Bush

A short-term DX-expedition that doubles as a vacation for the

operators is one thing — living and working in a rare DX spot is altogether something else. Do you remember Tanganyika (now part of Tanzania)? How about Kenya and Uganda? Here's the story of how amateur radio served as a link to the outside world from those countries, became an emergency line for medical help, and provided many amateurs with some fascinating contacts and sought-after QSL cards. Some of the exciting moments are related by author N. Steven-Hubbard, who, as VQ4NSH, operated within view of Kilimanjaro.

Noise Bridge Uses

You can check your antenna for resonance by using a transmitter and SWR meter, by using laboratory instruments, or you can just cut it to the recommended size and hope for the best. There's an easier way — an inexpensive, versatile, and accurate noise bridge. The expert on noise bridges, K6NY, tells you how it's done in clear and understandable terms.

Telephone Conversation With The Media — A Sketch In One Act

A fun encounter between a ham and the press. Perhaps there's more truth than fiction in this little episode by WB8QWP.

Is Your Station Really Safe?

Besides protecting your ham station and its equipment with fuses and circuit breakers, you can do several other things to ensure its safety. In this article about designing your station, W8FX explains what's needed to guarantee safety in the ham shack. Also included are some tips on what to do during emergencies.

All About Passive Filters

Sooner or later you're going to need a filter in your ham gear. These devices are necessary to tame unwanted frequencies and pass wanted frequencies. The filter article in this month's *Horizons*, by WA1TWT, is without doubt one of the easiest-to-understand treatments of an otherwise complex subject we've ever seen. It all begins on page 50.

A Construction Project for Antenna Enthusiasts

This month we present a homebrew antenna using wire elements for the three high-frequency bands: 10, 15, and 20 meters. Materials should cost next to nothing — most can be obtained from salvage yards or your junk box. The antenna features small size, wide bandwidth, and good environmental appearance.

The Cover

Alternative energy sources are the in thing these days, and tapping into windpower is one way to go. Wind-driven generators can be bought or built, and author WA1IAO built the 1-kW system shown on our cover. He tells you about it starting on page 12. Photograph taken at the Manchester (Connecticut) Radio Club Field-Day site by W1SL.

HAM RADIO HORIZONS November, 1978, Volume 2, No. 11. Published monthly by Communications Technology, Inc., Greenville, New Hampshire 03048. One-year subscription rate, \$10.00; three-year subscription rate, \$24.00. Second-class postage paid at Greenville, New Hampshire 03048 and additional offices.

This NEW MFJ Versa Tuner II . . .

has SWR and dual range wattmeter, antenna switch, efficient airwound inductor, built in balun. Up to 300 watts RF output. Matches everything from 1.8 thru 30 MHz: dipoles, inverted vees, random wires, verticals, mobile whips, beams, balanced lines, coax lines.



NEW, IMPROVED MFJ-941B HAS . . .

- More inductance for wider matching range
- More flexible antenna switch
- More sensitive meter for SWR measurements down to 5 watts output



\$89⁹⁵

Transmitter matching capacitor. 208 pf. 1000 volt spacing.

Sets power range, 300 and 30 watts. Pull for SWR.

Meter reads SWR and RF watts in 2 ranges.

Efficient airwound inductor gives more watts out and less losses.

Antenna matching capacitor. 208 pf. 1000 volt spacing.

Only MFJ gives you this MFJ-941B Versa Tuner II with all these features at this price:

A SWR and dual range wattmeter (300 and 30 watts full scale) lets you measure RF power output for simplified tuning.

An antenna switch lets you select 2 coax lines direct or thru tuner, random wire/balanced line, and tuner bypass for dummy load.

A new efficient airwound inductor (12 positions) gives you less losses than a tapped toroid for more watts out.

A 1:4 balun for balanced lines. 1000 volt capacitor spacing. Mounting brackets for mobile installations (not shown).

With the NEW MFJ Versa Tuner II you can run your full transceiver power output — up to 300 watts RF power output — and match your

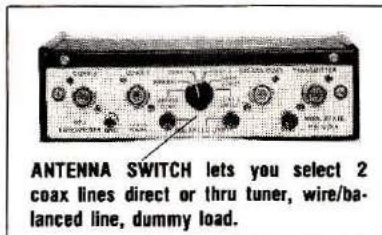

ANTENNA SWITCH lets you select 2 coax lines direct or thru tuner, wire/balanced line, dummy load.

transmitter to any feedline from 160 thru 10 Meters whether you have coax cable, balanced line, or random wire.

You can tune out the SWR on your dipole, inverted vee, random wire, vertical, mobile whip, beam, quad, or whatever you have.

You can even operate all bands with just

one existing antenna. No need to put up separate antennas for each band.

Increase the usable bandwidth of your mobile whip by tuning out the SWR from inside your car. Works great with all solid state rigs (like the Atlas) and with all tube type rigs.

It travels well, too. Its ultra compact size 8x2x6 inches fits easily in a small corner of your suitcase.

This beautiful little tuner is housed in a deluxe eggshell white Ten-Tec enclosure with walnut grain sides.

S0-239 coax connectors are provided for transmitter input and coax fed antennas. Quality five way binding posts are used for the balanced line inputs (2), random wire input (1), and ground (1).

NEW 300 WATT MFJ VERSA TUNER II'S: SELECT FEATURES YOU NEED.

NEW MFJ-945 HAS SWR AND DUAL RANGE WATTMETER.

\$79⁹⁵



Same as MFJ-941B but less 6 position antenna switch.

NEW MFJ-944 HAS 6 POSITION ANTENNA SWITCH ON FRONT PANEL.

\$79⁹⁵



Same as MFJ-941B but less SWR/Wattmeter.

NEW MFJ-943 MATCHES ALMOST ANYTHING FROM 1.8 THRU 30 MHz.

\$69⁹⁵



Same as MFJ-941B, less SWR/Wattmeter, antenna switch, mounting bracket. 7x2x6 in.

ULTRA COMPACT 200 WATT VERSA TUNERS FOR ALL YOUR NEEDS.

MFJ-901 VERSA TUNER MATCHES ANYTHING, 1.8 THRU 30 MHz.

\$59⁹⁵



Efficient 12 position air inductor for more watts out. Matches dipoles, vees, random wires, verticals, mobile whips, beams, balanced lines, coax. 200 watts RF. 1:4 balun, 5x2x6 in.

MFJ-900 ECONO TUNER MATCHES COAX LINES/RANDOM WIRES.

\$49⁹⁵



Same as MFJ-901 but less balun for balanced lines. Tunes coax lines and random lines.

MFJ-16010 RANDOM WIRE TUNER FOR LONG WIRES.

\$39⁹⁵



1.8 thru 30 MHz. Up to 200 watts RF output. Matches high and low impedances. 12 position inductor. S0-239 connectors. 2x3x4 inches. Matches 25 to 200 ohms at 1.8 MHz. Does not tune coax lines.

For Orders **Call toll-free 800-647-1800**

Order any product from MFJ and try it. If not delighted, return within 30 days for a prompt refund (less shipping).

Order today. Money back if not delighted. One year unconditional guarantee. Add \$2.00 shipping/handling. For technical information, order/repair status, in Mississippi, outside continental USA, call 601-323-5869.

Order By Mail or Call TOLL FREE 800-647-1800 and Charge It On



MFJ ENTERPRISES

P. O. BOX 494
MISSISSIPPI STATE, MISSISSIPPI 39762

NEW

HF VERTICALS BY CUSHCRAFT

10-15-20 METERS



ATV-3 Cushcraft's ATV-3 multiband vertical provides low VSWR operation for both SSB and CW on 10, 15, and 20 meters. Matched to 50 ohms, built-in connector mates with standard PL-259. Stainless-steel hardware is used for all electrical connections. The ATV-3 is a compact 166 inches (4.2 meters) tall. Rated at 2000 watts PEP.

10-15-20-40 METERS



ATV-4 The Cushcraft ATV-4 four-band vertical antenna has been optimized for wide operating bandwidth on 10, 15, 20, and 40 meters. SWR is less than 2:1 over the CW and SSB segments of 10, 15, and 20. The 2:1 SWR bandwidth on 40 meters is approximately 240 kHz; may be quickly and easily adjusted to favor any part of the band. Coaxial fitting takes 50-ohm transmission line with PL-259 connector. Overall height, 233 inches (5.9 meters). Rated at 2000 watts PEP.

10-15-20-40-80 METERS

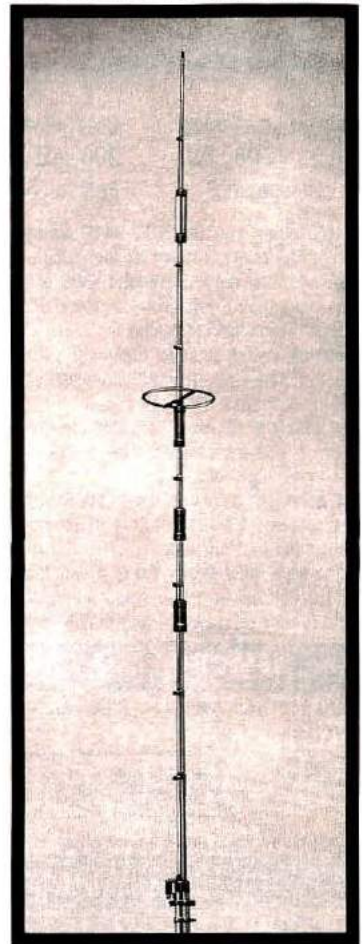

ATV-5 The ATV-5 trapped vertical antenna system has been engineered for five-band operation on 80 through 10 meters. The high Q traps are carefully optimized for wide operating bandwidth: 2:1 SWR bandwidth with 50-ohm feedline is 1 MHz on 10 meters; more than 500 kHz on 15 and 20 meters; 160 kHz on 40 meters; and 75 kHz on 80 meters. Instructions are provided for adjusting resonance to your preferred part of the band, CW or SSB. Built-in coaxial connector takes PL-259. Nominal height, 293 inches (7.4 meters). Rated at 2000 watts PEP on all bands.

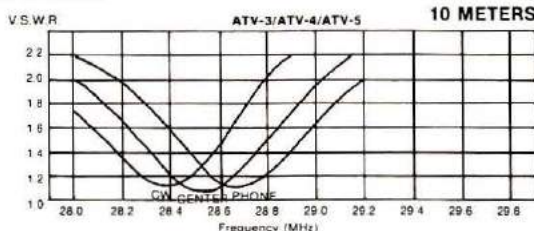
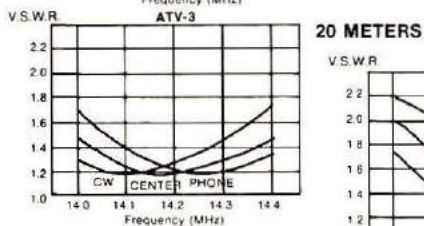
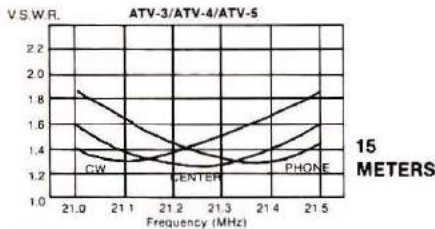

UPS SHIPPABLE

cushcraft
CORPORATION

THE ANTENNA COMPANY

IN STOCK WITH DEALERS WORLDWIDE
P.O. BOX 4680, MANCHESTER, NH 03108

November, 1978
Volume 2, Number 11

HAM RADIO HORIZONS

T.H. Tenney, Jr., W1NLB
Publisher
James R. Fisk, W1HR
Editor-in-Chief

Editorial Staff

Thomas F. McMullen, Jr., W1SL
Managing Editor
Patricia A. Hawes, WA1WPM
Executive Editor
Martin Hanft, WB1CHQ
Administrative Editor
Charles J. Carroll, K1XX
Joseph J. Schroeder, W9JUV
Alfred Wilson, W6NIF
Assistant Editors

Publishing Staff

C. Edward Buffington, WB1AMU
Assistant Publisher
Fred D. Moller, Jr., WA1USO
Advertising Manager
James H. Gray, W1XU
Assistant Advertising Manager
Susan Shorrock
Circulation Manager

Copyright 1978 by Communications
Technology, Inc. Title registered
at U.S. Patent Office

Subscription rates are
\$10.00 per year, worldwide

Microfilm copies
are available from
University Microfilms, International
Ann Arbor, Michigan 48103

Cassette tapes of selected articles
from *Ham Radio Horizons* are available to
the blind and physically handicapped
from Recorded Periodicals
919 Walnut Street, 8th Floor
Philadelphia, Pennsylvania 19107

Ham Radio Horizons
is published monthly by
Communications Technology, Inc
Greenville, New Hampshire 03048
Telephone 603-878-1441

CONTENTS

Windpower For Your Amateur Station	12	
John J. Shelley, WA1IAO		
Propagation and The Ham Bands	24	
William I. Orr, W6SAI		
Amateur Radio In Safariland	30	
N. Steven Hubbard, Ex-VQ4NSH		
Use A Noise Bridge	38	
Jack Althouse, K6NY		
The Press and I	42	
Paul R. Kalahar, WB8QWP		
Designing Your Own Station, Part 3	44	
Karl T. Thurber, Jr. W8FX		
Know Your Filter Circuits	50	
Paul G. Schreier, WA1TWT		
A Simplex Three-Band Antenna	56	
John P. Tyskewicz, W1HXU		
Activities Calendar	92	Horizons Locator 82
Ad Check	94	Newsline 11
Ad Scan	87	Post Box 66
Advertiser's Index	94	Product Showcase 68
Benchmarks	62	Propagation Chart 91
DX Forecaster	90	This Month's Horizons 2
Focus and Comment	8	

THE VIEW FROM HERE



November 27th marks the 55th anniversary of one of Amateur Radio's most memorable events — the first *two-way* Amateur communications across the Atlantic Ocean. It was a hard-won goal, its path marked with failure and frustration, but when the Atlantic, at last, had been spanned, it was conquered by short-wave Amateur Radio, on wavelengths that previously were considered to be useless.

The first Transatlantic tests, in December, 1920 were a dismal failure, as were another series of tests conducted in February, 1921. The 250 or so British stations which were listening for prearranged signals from the United States on a wavelength of 200 meters (1.5 MHz) jammed each other so badly with radiations from their own regenerative receivers that they couldn't hear any signals from across the pond!

A second Transatlantic test was scheduled for December, 1921. In November, Paul Godley, 2XE, designer of the famous Paragon receiver, sailed from New York with two receivers under his arm — one a standard regenerative set with two stages of audio amplification, the other a 10-tube Armstrong superheterodyne built especially for the tests.

With this superhet and a wire antenna 1300 feet long installed on the Androssan moor on the coast of Scotland, not far from Glasgow, Godley heard the first Stateside signals coming through in the wee hours of the morning on December 8th. Over the next few days Godley copied the signals of 27 different American amateur stations; on December 12th he received the first complete message from the United States to Europe on the "short waves." British amateurs also participated in the tests, and when all the reports were analyzed it was discovered that W. F. Burne, G2KW, actually made the *first* positive identification of an American amateur signal.

During similar tests a year later, two European stations, F8AB in Nice, and G5WS in London, were heard by amateurs along the east coast of the United States, and many American signals were logged in Europe, but two-way communications were not established (but probably only because no one apparently took the initiative to try).

A fourth series of Transatlantic tests were scheduled for late 1923. However, these carefully laid plans were totally upset by the enterprise of one man, Leon Deloy, F8AB. Deloy came to the States during the summer of 1923 where he met with John Reinartz, 1XAM, and Fred Schnell, 1MO. Deloy picked up much valuable advice from his talks with Reinartz and Schnell, and before returning to France he acquired a new Grebe receiver and the details of a "trick" circuit which, he was told, would "go down to about 100 meters" (3 MHz). Up until that time all the Transatlantic tests had been conducted on a wavelength around 200 meters.

Deloy put his new 100-meter station on the air in early autumn, and having satisfied himself that everything was in working order, cabled Schnell that he would transmit on 100 meters between 0200 and 0300 GMT on November 26, 1923. The signals from F8AB were heard by Schnell and Reinartz almost from the first dot he transmitted, but the Americans were not ready to transmit back. Unlike Deloy, who presumably did not think it was necessary to obtain official permission to transmit on such a short wavelength, Schnell had to seek the necessary authority from the Radio Supervisor in Boston.

On November 27th Schnell received special permits from Boston for himself and Reinartz. Late that night (early morning in Europe) they were both on the air. For an hour Deloy called the United States and then sent two messages. At 0330 GMT he signed off and asked for acknowledgement. Long calls followed from 1MO and 1XAM. Then came the eagerly awaited reply — Deloy had clearly heard both stations. Reinartz was asked to stand by as Deloy transmitted to Schnell, "R R QRK UR SIGS QSA VERY ONE FOOT FROM PHONES ON GREBE FB OM HEARTY CONGRATULATIONS THIS IS A FINE DAY — PSE QSL." It was, indeed, a fine day.

Jim Fisk, W1HR
editor-in-chief

ICOM stacks it all in your favor.



All ICOM radios significantly exceed FCC specifications limiting spurious emissions.

HF/VHF/UHF AMATEUR AND MARINE COMMUNICATION EQUIPMENT

DISTRIBUTED BY:



ICOM

ICOM WEST, INC.
Suite 3
13256 Northrup Way
Bellevue, Wash. 98005
(206) 747-9020

ICOM EAST, INC.
Suite 307
3331 Towerwood Drive
Dallas, Texas 75234
(214) 620-2780

ICOM CANADA
7087 Victoria Drive
Vancouver B.C. V5P 3Y9
Canada
(604) 321-1833



FOCUS & COMMENT

A letter I received the other day started me thinking about the differences between Amateur Radio in the old days and today. The letter was only one of many of similar vein, but it triggered the comparison process. Surely, if a number of people are thinking along the same lines the subject is worth a bit of examination.

"Things sure were simple in the old days," the writer stated, "you just plugged a key into the cathode or B- line and worked people. No dozens of transistors between the key and the rig." Other writers have expressed similar observations about the complexity of today's equipment and the utter simplicity of yesteryear's rigs.

They're right, things were more simple. My first rig was a brute-force oscillator (6L6) which consumed more power than a lot of complete transceivers today, followed by an 807 amplifier which generated something like 80 to 100 watts on 80 meters, and who knows how much up through the rest of the spectrum. The rig never got me into trouble because there were no neighbors with stereo, fm, TV, or electronic organ consoles to be bothered by the harmonics and other "garbage" put forth by the circuitry of the day.

My first Amateur Radio field day was in a remote part of the Appalachian mountains, and the rigs used were primitive, even for those days. The mainstay of the weekend was a pair of 807s, hooked up as a push-pull, cross-coupled oscillator; it was a 100-watt vfo! Keying was done in the B- lead from the power supply, and a neophyte such as I soon learned that you kept your fingers off the metal parts of the key, and, just to be sure, you *never* touched the receiver while you were transmitting. Negative 800 volts packs just as much a wallop as positive 800!

Yes, things were simpler then — we didn't have parents just waiting to find some excuse for a law suit if their youngster stuck his finger in the wrong place. There was no OSHA or similar branch of government inspecting TV sets and other electronic gadgetry to see if the chassis was "live" with ac from the power cord. There were no hundreds of one-eyed monsters within a mile of our rig, all waiting to turn their viewers into irrational adversaries at the touch of a microphone or key.

The Amateur bands were simpler, too. You could sometimes tune several *kilocycles* between signals on the 20-meter band, and there was so much room on 40 and 80 meters that several well-known amateurs had their own "unofficial" frequencies staked out without arousing the ire of the rest of us. Key clicks? No problem — just move away from them, up the band a bit. Frequency drift? The receivers were generally so broad that most operators never noticed it unless you really overcoupled power out of the oscillator. Chirp? Everyone had it, even many of those stations using crystal control.

But, like the rest of the world with its increasing population and resulting restrictions on freedom, Amateur Radio has grown. It has become more complex, and vastly more crowded. The simple techniques will still work, to be sure, but our fellow hams cannot put up with them. (Nor can our non-ham neighbors.) Fortunately, technology has advanced in a manner that will allow us to continue to enjoy our hobby. There are few among us who would opt for the oldtime two-mode bands (CW and a-m) rather than our present SSTV, RTTY, CW, ssb, fm, a-m, ATV, and more.

And how about the marvelous high-speed CW I hear zipping about the bands? Modern circuitry has allowed it to be clean, crisp, and intelligible at 80+ words per minute. It was a rare cathode-keying and bug combination that could put out clean dots and dashes at more than 35 wpm. Voice modulation? Just tune across 75 or 20 meters sometime, count the stations you hear, and then give them 6 to 8 kHz of space instead of the 2.3 to 3 they now occupy. Where did the band go?

Yes, things were simpler, and those days are nice to contemplate and perhaps feel a brief sense of loss over. Progress is often a hard lump to swallow, especially when it runs head-on into experience and habit. But I'm positive that Amateur Radio couldn't live without it.

Thomas McMullen, W1SL
Managing Editor

Full Features and Superior Performance ST-6000 RTTY DEMODULATOR

Select Rx & Tx Shifts
Accurately Tuned Rx Filters
Crystal Controlled Tx Tones
True Transceive Operation

Invert Both Rx Demod,
and Tx Tones

Data Status Indicators
Loop 1 Post-Autostart Pre-Autostart



Hard-Limiting [FM]
or
Non-Limiting [AM]
Reception

Correct for
Bias Distortion

Correct For
Multi-Path Distortion

Local Loop Operation

Autostart with:
◦ Motor Control
◦ Mark Hold
◦ Antispace

Tuning Oscilloscope
[Front Panel Controls]
Meter Indicator Option
Also Available

Automatic Tx/Rx Station
Control with Keyboard
Operated Switch [KOS]



Why not have the best?

The HAL ST-6000 Demodulator offers outstanding performance, versatility, and ease of operation. The Receive Demodulator features multiple-pole active filters available for "high" or "low" tones. These filters are frequency-matched to the transmit tone crystals for true transceive operation. Input bandpass filters, discriminator filters, and post-detection filters are carefully designed and tested for optimum weak-signal recovery. The ST-6000 has an internal loop power supply, 2 loop keyers, RS-232, MIL-188C, and CMOS data I/O, and rear panel connections to data and control circuits for connection to UART and computer devices. Use it with the HAL DS-3000 KSR for the best in RTTY performance.

\$595.00

Write today for HAL's latest RTTY catalog.



HAL COMMUNICATIONS CORP.
Box 365
Urbana, Illinois 61801
217-367-7373

For our Overseas customers:
see HAL equipment at:
Richter & Co.; Hannover
I.E.C. Interrelco; Bissone
Vicom Imports; Auburn, Vic., Australia

THE SWITCH IS ON!

Not only is the big move to switch to the Wilson Mark Series of Mini-Hand-Held Radios, but now the switch is on the Mark!

Wilson Electronics, known for setting the pace in 2m FM Hand-Helds, goes one step beyond!

AT NO EXTRA CHARGE: all Mark Series Radios now will include a switch for you to control the power of operation. This will enable you to use the high power when needed, then later switch to low power to conserve battery drain for extended operation.

IN ADDITION: all Mark Series Radios now have an LED Battery Condition Indicator conveniently mounted on the top plate. A quick peek will reassure you of a charged battery in the radio.

Wilson hand-helds have been known world-wide for exceptional quality and durable performance. That's why they have been the best selling units for years.

Now the Mark Series of miniature sized 2-meter hand-helds offers the same dependability and operation, but in an easier to use, more comfortable to carry size . . . fits conveniently in the palm of your hand.

The small compact size battery pack makes it possible to carry one or more extra packs in your pocket for super extended operation time. No more worry about loose cells shorting out in your pocket, and the economical price makes the extra packs a must.

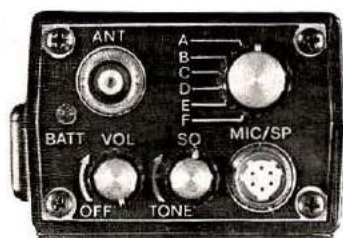

Conveniently located on top of the radio are the controls for volume, squelch, accessory speaker mike connector, 6 channel switch, BNC antenna connector and LED battery condition indicator.

Optional Touch Tone™ Pad available.

To obtain complete specifications on the Mark II and Mark IV, along with Wilson's other fine products, see your local dealer or write for our Free Amateur Buyer's Guide.

— NOW SWITCHABLE —
MARK II: ≈ 1 & 2.5 watts
MARK IV: ≈ 1.5 & 4.5 watts

SPECIFICATIONS

- Range: 144-148 MHz
- 6 Channel Operation
- Individual Trimmers on TX and RX Xtals
- Rugged Lexan® outer case
- Current Drain: RX 15 mA
TX - Mark II: 500 mA
TX - Mark IV: 900 mA
- 12 KHz Ceramic Filter and 10.7 Monolithic Filter included.
- 10.7 MHz and 455 IKz IF
- Spurious and Harmonics: more than 50 dB below carrier
- BNC Antenna Connector
- .3 Microvolt Sensitivity for 20 dB Quieting
- Uses special rechargeable Ni-Cad Battery Pack
- Rubber Duck and one pair Xtals 52/52 included
- Weight: 19 oz. including batteries
- Size: 6" x 1.770" x 2.440"
- Popular accessories available: Wall Charger, Mobile Charger, Desk Charger, Leather Case, Speaker Mike, Battery Packs, and Touch Tone™ Pad.



Illustrated is Wilson's BC-2 Desk Top Battery Charger shown charging the Mark Series Unit or the BC-4 Battery Pack only.

Consumer Products Division
Wilson
Electronics Corp.

4288 South Polaris Avenue • P. O. Box 19000 • Las Vegas, Nevada 89119
Telephone (702) 739-1931 • TELEX 684-522

NEWSLINE

BALLOON MOBILE AMATEUR RADIO provided the Double Eagle II with vital communications as the 112 foot high balloon became the first lighter-than-air craft to cross the Atlantic. The balloonists, operating as W5OCP on 14325 kHz, maintained contact with their ground crew in Bedford, Massachusetts, using an Atlas transceiver.

Though None Of The Three balloonists were themselves Amateurs, there were Amateurs (including W5OCP) in the Eagle II's ground support crew. The Atlas had been taken along for compact, lightweight backup communications, and when the crew found themselves without other communications halfway through their trip, their emergency use of Amateur frequencies under paragraph 1381 of the International Radio Regulations was appropriate.

Another Adventurer, Naomi Uemura, JG1QFW, was in Washington in late August for a press conference and a celebration of his accomplishment: reaching the North Pole solo. With much of the trip's communications burden carried by Amateur Radio, lots of good PR should result.

AMATEURS PUTTING HR REPORT or other items of "general interest to Amateurs" on the air as a "QST" are generally well within the FCC's rules, but should be discreet with respect to some types of stories. True news stories pose no problem, but job offerings should probably not be aired at all; announcements of new products, forthcoming books, and the like should be treated strictly as news without price or "where to buy" details, to avoid any appearance of commercialism. The rules do not appear to be as restrictive for 2-way contacts, however, as they are for QSTs.

LORAN-A IS GOING TO CONTINUE plaguing 160-meter buffs a bit longer than had been expected. The Coast Guard has requested a six-month extension of the obsolete navigation system, and Secretary of Transportation Brock Adams has approved the request.

The New Shutdown Date for Gulf of Alaska and West Coast Loran-A is December 31, 1979, while the Atlantic Seaboard, Gulf of Mexico, and Caribbean systems are to follow suit a year later. The KH6s aren't affected, however, as Loran-A in the Islands is still due to leave the air July 31, 1979.

AMATEUR RADIO found a receptive audience at the August hearings in Chicago on the revision of the Communications Act of 1934. Barry Bayer, K9CFV, an attorney and a director of the Chicago FM Club, represented the Amateur Service before Congressman Russo's group. In his presentation, Barry highlighted Amateur contributions in both public service and technology, and made specific recommendations of change pertinent to Amateurs. In support of his oral presentation, Barry also provided the committee with an eight-page written document.

Congressman Russo seemed quite interested in Barry's proposals for Amateur Radio, even interrupting him at times to ask for elaborations and suggesting that he work up the kind of definition of Amateur Radio that the act should include. The half dozen or so Amateurs attending the session all agreed they'd had a very fair, albeit brief, hearing, and that the efforts made by Barry and the group working with him - W9CI, W9HPG, W9MOL, and others of the Chicago QCWA chapter, plus members of the Chicago FM Club - had been very worthwhile.

FCC's Present Amateur Study Guides are "adequate and consistent with the privileges permitted each class of license," reported a QCWA task force. The QCWA President W6ATC and Secretary K4LMB reported its favorable conclusions in a meeting with John Johnston at the FCC late in August.

Telephone Interconnection will be prohibited for both the General Mobile Radio Service (UHF-CB) and the Industrial Radio Services. In a Report and Order on Docket 20846, the Commissioners decided that the autopatch and other direct radio-telephone links being provided to users by GMRS and industrial system operators are indeed Common-Carrier functions and not appropriate to those services.

Though This Decision does not bear directly on Amateur autopatch and phone-patch use, it certainly indicates a train of Commission thought that could bode ill for Amateurs.

DRAKE ANNOUNCED THREE NEW pieces of equipment at the W9DXCC's annual meeting in Chicago in September. The MN-2700 is a 2000-watt 160-10 meter antenna-matching network capable of working into coax, balanced lines, or a long-wire antenna. It's to be on the market around the end of the year.

A New Low-Priced, all-band transceiver is also in Drake's planning, though further downstream. At this early stage they'd like suggestions from interested Amateurs as to what such a rig should include - write W8AD at Drake. Drake is also planning a new desk-top kilowatt linear, styled to be compatible with the TR-7 and the new low-cost transceiver.

2X1 CALLSIGNS are proving popular with Extras. AG prefixes are already being heard from the 4th and 6th call areas, and AF prefixes are in use by 2s and 5s. The rest of the continental U.S. apparently hasn't gotten past the ADs.

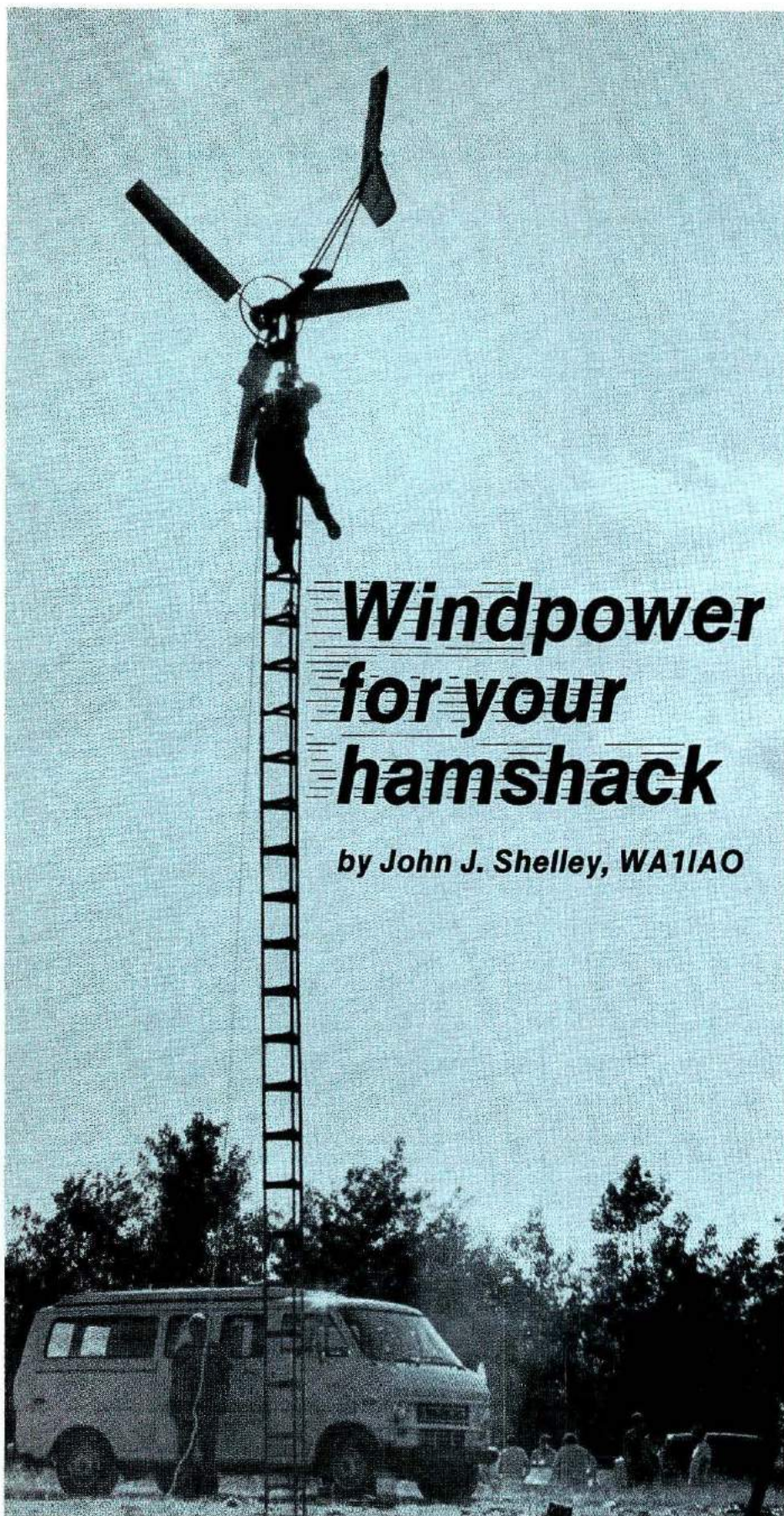

Windpower for your hamshack

by John J. Shelley, WA1IAO

Great sums of money are being spent by both the government and private enterprise in an effort to find efficient ways to use wind energy. Many hours have been invested in designing and testing huge windmills with blades of up to nine meters (30 feet) long, mounted on towers that are equally impressive and capable of cranking out thousands of kilowatts. Other designs which show promise appear to be overgrown eggbeaters, expanded versions of attic ventilating systems, and collections of steel drums. Most of them work, to some extent, but the refinements and technology necessary to make the systems productive are beyond the average amateur who wants to tap into a little "free" power for his home or radio equipment.

Many of the old-timers can remember the two- and three-bladed wind-powered generators that saw a spurt of popularity in the 1920s and 1930s. They provided power for small lighting systems, ran some pumps or other machinery, and occasionally powered a radio receiver for the latest in news and entertainment. Some of them are still available in out-of-the-way places, and bring a premium price when rebuilt by a skilled mechanic. The expansion of commercial electricity into the rural areas forced most of those generators into early retirement.

The wind is still there, however, and it is now the "in" thing to find and use alternative sources of energy; blades can be seen spinning in many locations today. Before you rush out and start buying hardware, though, there are a few things you should consider.

Site selection

If you want to know where the wind is, go fly a kite. Try it for several days and during different conditions; what is happening on the ground does

not necessarily indicate conditions up where the kite (or windmill) will be. Move around to locate the area with least turbulence. A steady wind is more useful than a gusty one that changes direction and velocity at frequent intervals.

The altitude of best wind conditions will indicate how

wind speeds and directions at ground level, where people walk around and planes take off and land. It is not uncommon for the wind to be almost calm near the ground but to have the windmill cranking out full power at the 18-meter (60-foot) level.

is given as $1/2 \rho AV^3$, or $1/2$ the air density (ρ) \times windmill area (A) \times windspeed (V^3). This means that cold, dense, air will give more power than will hot air, and a larger mill, of course, will be more powerful. The important factor is the velocity — the

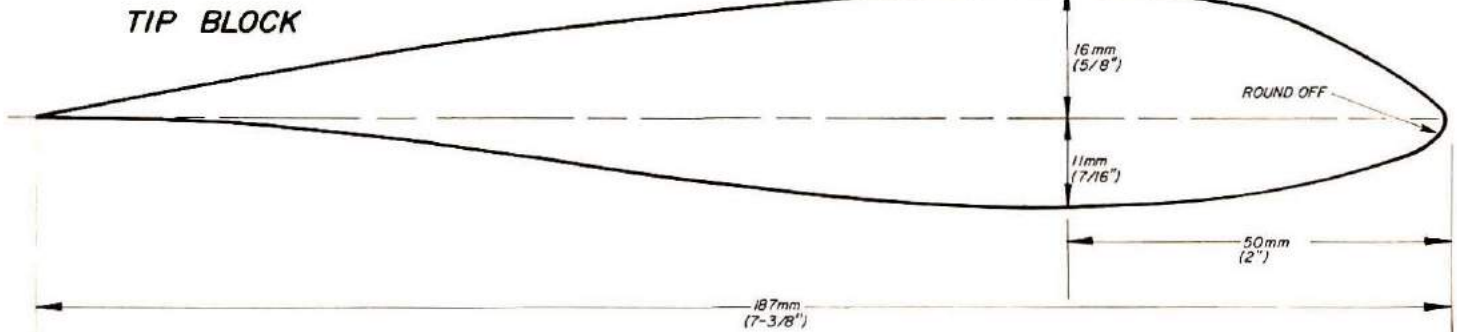

Fig. 1. Blade-tip blocks are made of wood and shaped to the desired airfoil, as shown here approximately full size. The blocks should be approximately 25.4 mm (1 inch) thick. Apply a good penetrating moisture-sealant varnish to the end grain.

high you must make the tower to hold the generator, but you should figure on nine meters (30 feet) as a starting point for an exposed location. Trees, buildings, and nearby terrain will modify that height, almost always in the upward direction. Foliage in the surrounding area will be a factor; wind patterns will differ from winter to summer. Where I live, in New England, summer winds are usually the least favorable for producing power.

The local weather report will tell you very little about winds in specific areas or at any useful altitude. They report

There are some really bad places to locate a windmill, notably on the lee side (downwind) of a hilltop. Surprisingly, the very top of a hill may not be good either. This is because the inertia of the mass of air rushing up the slope causes it to "overshoot," leaving a pocket of either calm or turbulent air under it. These sites can be used, however, it's just a matter of finding the right spot and the correct tower height to tap into the air stream.

How much power?

The power in a wind stream

power does not change evenly as the velocity does. There are minor changes up to about 16 km/h (10 mph), but the changes are radical above that speed and become a major factor. For instance, a 3-meter (10-foot) turbine will have the power to light a 100-watt bulb in a 16 km/h (10 mph) wind, but at twice that speed there is a yield of 800 watts (2^3 , or $2 \times 2 \times 2$) or more.

This is not all purely a positive factor in the design. If a machine is made to be efficient with the usual, or average, winds in a particular area, it will not necessarily be

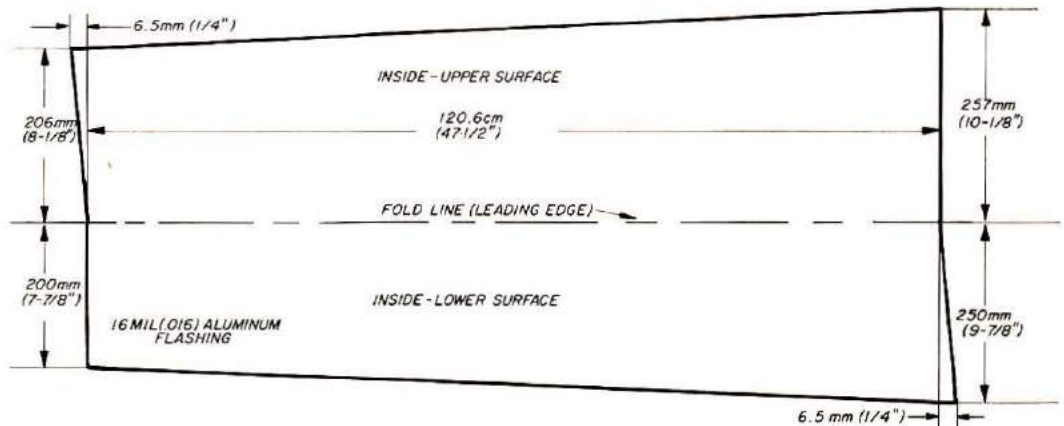

Fig. 2. A sheet of 16-mil aluminum flashing material should be cut as shown for each blade. Note that two of the corners are not square. This is to allow for skewing of the sheet when it is formed into a blade.

safe at higher speeds unless designed strong enough to handle the stresses involved. It is not unusual for velocities to double or triple during short

km/h (10 mph). As the wind becomes stronger it would be desirable to have a varying load to keep the output voltage constant, but, for most applications, this is not necessary. When full power is

severe storms, at which time the mill should be stowed (deactivated) by folding the tail assembly parallel to the blades.

The turbine described in this article employs all these principles in a lightweight, durable, but inexpensive arrangement that can be built with materials readily available in hardware stores and junkyards.

Building the machine

My wind turbine has three blades, fabricated from flashing-aluminum sheet, which have a nonlinear twist to their surfaces so the airfoil presents a different angle of attack at the tip than at the base of the blade. The blades are mounted to a hub assembly in such a manner that a centrifugal mechanism can change their pitch, thus providing automatic feathering (speed control) as wind speed increases. The hub assembly is coupled to the generator by means of a modified bicycle-wheel and V-belt arrangement. A tail-vane keeps the blades headed into the wind, except in case of storms, when a release mechanism can be activated to turn the vane to one side, thereby positioning the blades parallel to the wind. Slip rings are used to transfer power across the rotary joint at the top of the support mast.

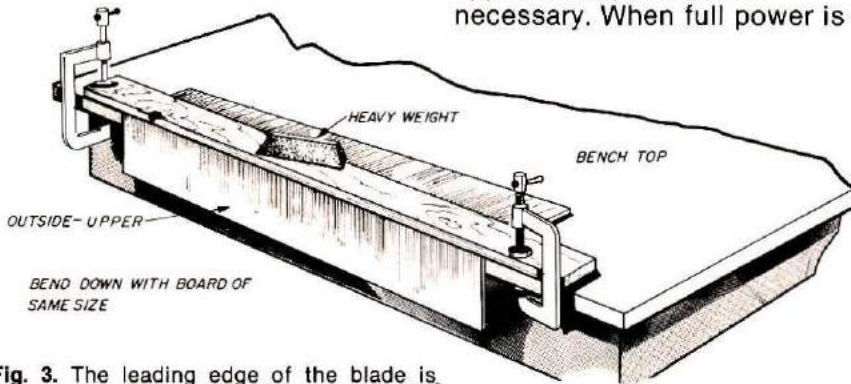

Fig. 3. The leading edge of the blade is started by forming a bend over the edge of a workbench. A board, C-clamps, and weights are used to keep the stationary part from slipping.

periods of time, so a generator that is developing 1 kW at 35 km/h (22 mph) will produce 8 kW at 70 km/h (44 mph), on up to 64 kW in a 141 km/h (88 mph) wind. This is almost 86 true horsepower. Therefore, the machine must be strong enough to withstand the power equivalent to that of a large automobile (or be designed to avoid developing that much power in high winds).

Designing a thousand-watt wind turbine has been a valuable education for me in many arts and sciences. One cannot just shape a blade, fix it to a generator, and place it on a pole. The generator has to produce power up to a given wind speed, and then taper off to prevent overloading the electrical and mechanical system during high winds. It should also be capable of being disabled for safety during storms.

Desirable features

A summary of the operations involved in a wind-electric system is as follows: a wind-operated vane-switch connects the generator field to a battery, (much as an automobile ignition switch does) when the wind reaches some predetermined velocity, say 16

reached at somewhere near 35 km/h (22 mph), there must be a provision for reducing the efficiency of the blades so as not to exceed the safe rotational speed and electrical power output. If the load is increased there is a danger of burning out the generator. If higher-capacity components are used, you will waste money and effort trying to use these infrequent high-velocity winds.

One answer to overspeed protection is mechanical governing, which feathers the blades and spoils their lift factor, thus making them less

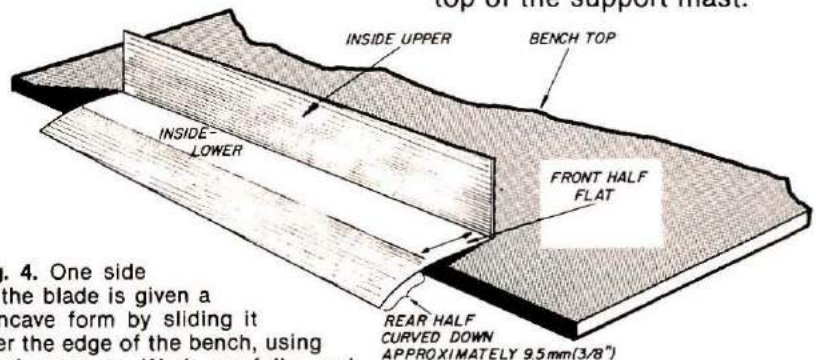

Fig. 4. One side of the blade is given a concave form by sliding it over the edge of the bench, using hand pressure. Work carefully, and keep the pressure even so as not to form wrinkles (which will eventually cause cracks).

efficient. This system should react to sudden gusts, loss of load or excitation, and be able to handle excess wind velocity up to the point of

There are some interesting problems involved in forming the airfoil for the blades, so approach them slowly and do the job carefully. Blades are the

high-speed parts of the mill, and any imbalance or poor workmanship here will show up as inefficiency or vibration. An out-of-balance blade assembly, in a high wind, can destroy itself (and perhaps the tower as well) in short order.

Blade forming

To start, make three wooden blade-tip blocks 2.5 cm (1 inch) thick, as shown in Fig. 1.

Thoroughly saturate them with varnish for weatherproofing. Then, mark and cut a sheet of 16-mil aluminum flashing as in Fig. 2. Fold it to a 90-degree bend as in Fig. 3. A concave surface is formed in the rear half of the underside by sliding it over the edge of the bench.

Be sure that the metal forms a smooth curve downward, see Fig. 4. Then cut out a wooden form according to Fig. 5, and clamp its right-hand end to a bench or large board. Lean the lower trailing edge of the folded metal over the top of the form, block the right-leading edge with a heavy weight to keep it from moving forward, and also lean the weight over the blade to keep it from rising off the bench during the twisting operation. The upper surface is then pressed over, by using a board 2/3 the length of the blade, so that the trailing edges come together over the form. The board is used to keep the metal from kinking. Align the metal, weights, and blocks so that the trailing edges slightly protrude over the near edge of the form. Place a weight on the folding board to hold it down. Insert a tip block and clamp it down near the trailing edge (Fig. 6). The blade now has a linear twist and has to be

shaped over the nonlinear form. This should be carefully done, keeping in mind that the true airfoil is not as important at the base as it is at the tip, and a

be even, so, during the next step, when you drill holes for rivets, be sure that each center-punch mark is 5 mm (3/16 inch) in from the innermost edge.

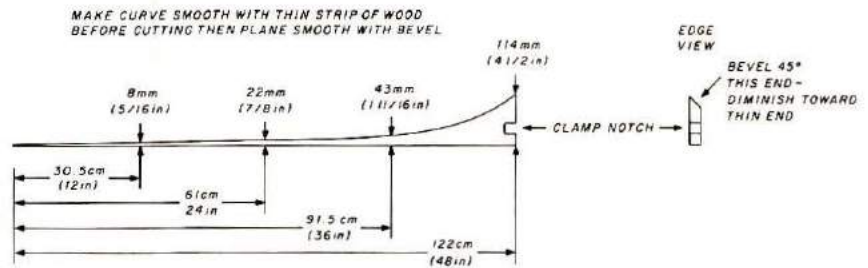

Fig. 5. The trailing edge of the blade must be given a twist, so that the airfoil near the tip is at a different angle of attack from that at the hub. Make a wooden form as shown here and clamp it to the edge of your workbench. Note that the upper surface is tapered, and the taper faces away from you when you press the blade to the form.

smooth curve yields a stronger blade. Kinks will cause popping and eventual cracking.

Starting at the tip of the blade, gradually push the trailing edges together against the form and clamp them at intervals of 12 cm (5 inches). Repeat the process a few times, loosening the clamps and allowing the metal to slip as each clamp is removed and replaced. When the edges fit the form closely they will not

The upper and lower trailing edges may slip as much as 12 mm (1/2 inch) under or over the other. The meeting points of the trailing edges should be the same on all three blades (see Fig. 6B).

Start the holes for rivets 19 mm (3/4 inch) from the tip end, and drill them at 50-mm (2-inch) intervals. If the curve is held carefully while you drill the holes, the rivets will bring the skin back to proper shape. The key to obtaining smooth, strong blades is to work slowly and carefully, and not to use excessive pressure in any one place. Use 3-mm (1/8-inch) aluminum rivets to join the trailing edges.

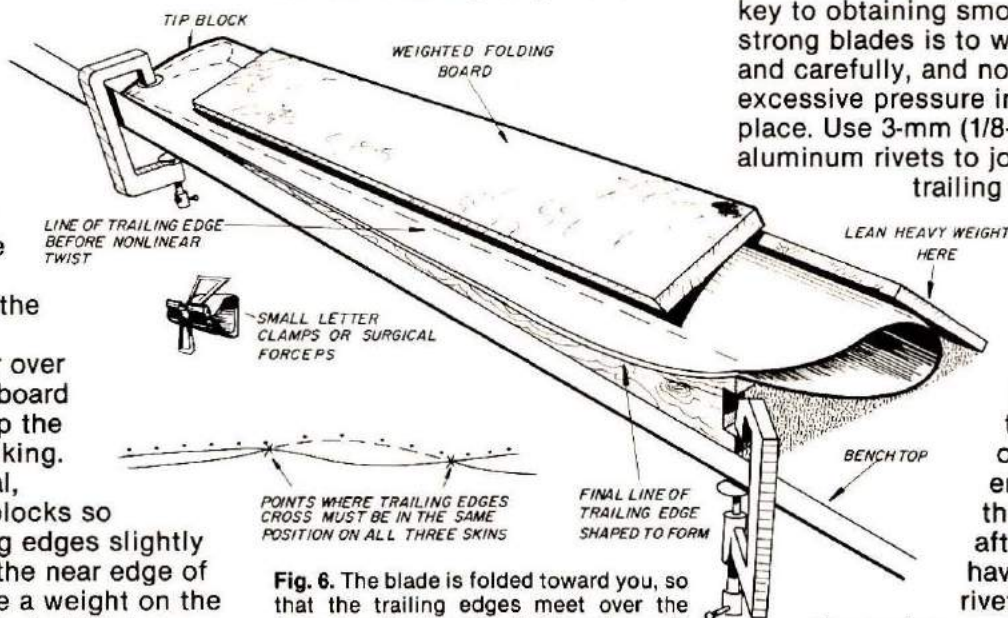

Fig. 6. The blade is folded toward you, so that the trailing edges meet over the form described in Fig. 5. The edges will cross at two points along their length. The location of the crossing-points must be the same on all three blades. Several small clamps are used to hold the edges together.

The pattern for the base former is obtained by tracing the outline of the base ends of all three skins, after they have been riveted, on a piece of paper. Use a common chord line from tip to tip. Superimpose all three traced outlines, and, using a French

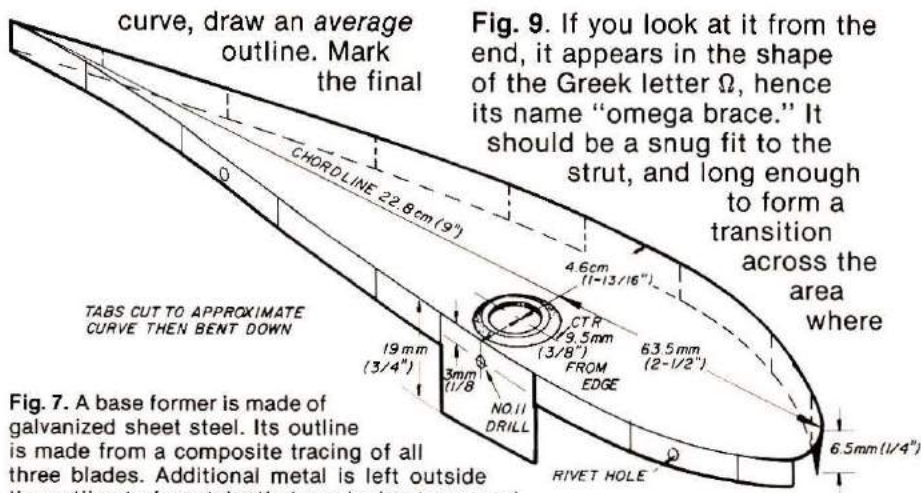

Fig. 7. A base former is made of galvanized sheet steel. Its outline is made from a composite tracing of all three blades. Additional metal is left outside the outline to form tabs that can be bent over and riveted inside the base of the blade. The hole for the support rod is "dimpled," or cone-shaped, to make a tight fit to the rod. Note the longer tab adjacent to the support-rod hole.

outline 1.5 mm (1/16 inch) inside the average one. Transfer this outline to a piece of sheet metal by using carbon paper. On the outer edges of this outline add 6.5-mm (1/4-inch) tabs, which will later be bent over and riveted to the skin. The length of each tab, between slits, is determined by the sharpness of the curve (see **Fig. 7**).

The base-former has two functions: it forms the skin to an airfoil at the base of the blade (near the hub), and it provides a mechanical connection between the blade and the strut/shaft assembly from the hub. The hole for the strut should be drilled or punched slightly undersize and then worked open from the inside by using a tapered punch or rounded tool. This will form a cone-shaped surface and edge that will provide a tight fit to the strut.

The blade needs some stiffening along its length, which is provided by a full-length strut and an "omega" brace. The strut is a piece of thin-wall steel tubing (conduit), 137 cm (54-1/4 inches) long. The brace is made of 1.5-mm (1/16-inch) aluminum which has been formed over a piece of rod or conduit as shown in

Fig. 9. If you look at it from the end, it appears in the shape of the Greek letter Ω , hence its name "omega brace." It should be a snug fit to the strut, and long enough to form a transition area where

the shaft ends and the strut continues alone.

Before you insert a strut in a blade, form a slight bow in the piece of conduit. If the bend is approximately 19 mm (3/4 inch) high near the center, the strut can exert pressure on the surface of the blade from the inside. This forms a more rigid blade and helps keep the rivets from working loose. Note that the bow will be toward the front of the assembled blade — facing the wind.

To obtain a centerline for marking and drilling the blade and strut, temporarily assemble the wooden tip former, the strut, and the base former. Use a steel tape, or wire stretched tightly between the tip and the base

of the blade to mark the center line. You can use a predrilled omega brace to locate the holes for it. The brace and strut are fastened by means of pop-rivets, with the first hole for a rivet in the hollow strut located 17.8 cm (7 inches) from the base of the blade. There should be a rivet every 7.6 cm (3 inches) along the centerline from there to the tip. The shaft and strut together will be drilled and tapped with a 10-24 (M5) thread at a point 29.5 cm (11-9/16 inches) from the inner end of the shaft (see **Fig. 10**).

After the strut and brace have been drilled and riveted in place, the base former can be positioned and the tabs riveted to the skin. The tip former is fastened by small wood screws.

Hub assembly

An automotive front-wheel hub offers a rugged means of mounting the blades; I used one from an American Motors Rambler. A second one is used for the azimuth-bearing assembly that allows the mill to follow the wind

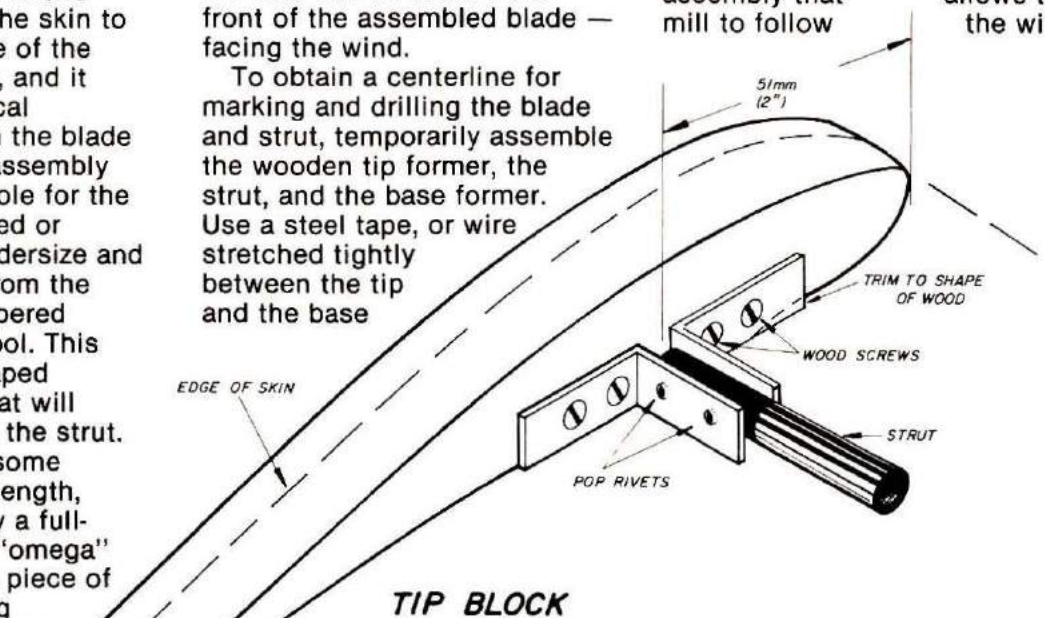

Fig. 8. Tip blocks are attached to the blade-reinforcing strut by small pieces of angle stock. They are installed parallel to the chord line, which means that some metal will have to be trimmed from one of them so as not to interfere with the aluminum skin.

direction. Threaded rods are mounted to the hub flange as shown in Fig. 11. These rods provide a means for pulley mounting, wobble

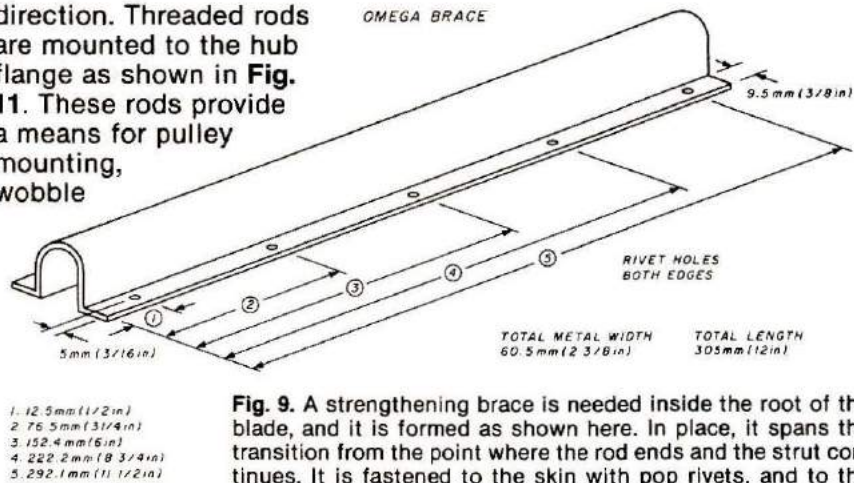

Fig. 9. A strengthening brace is needed inside the root of the blade, and it is formed as shown here. In place, it spans the transition from the point where the rod ends and the strut continues. It is fastened to the skin with pop rivets, and to the rod/strut with screws.

adjustment, blade tracking, and pitch-control-mechanism mounting.

The blade speed requires an 8-to-1 step up to drive the generator, which is accomplished by means of a bicycle wheel. I made new hub plates to mount the wheel to the threaded rods in the hub assembly. These plates are

drilled as shown in Fig. 13. Any other means of providing a V-belt drive pulley with a diameter of 60 cm (24 inches) will be fine, as long as you can mount it to the hub assembly and allow for adjustment to remove wobble.

The main plate for the hub assembly must be made with great care to maintain balance

This is the main plate as seen from the front. The blade-support rods go through bearing blocks and are secured by a small bolt at their inner ends. The nuts and bolts have been drilled through and cotter pins inserted for security against vibration. Two metal washers with a Teflon washer between are used to lessen friction when the rods rotate (photo by W1SL).

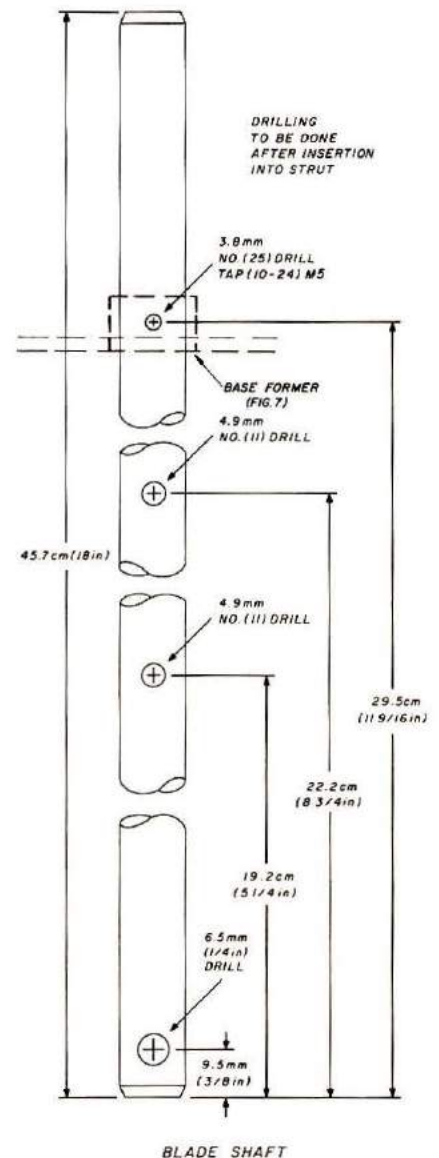
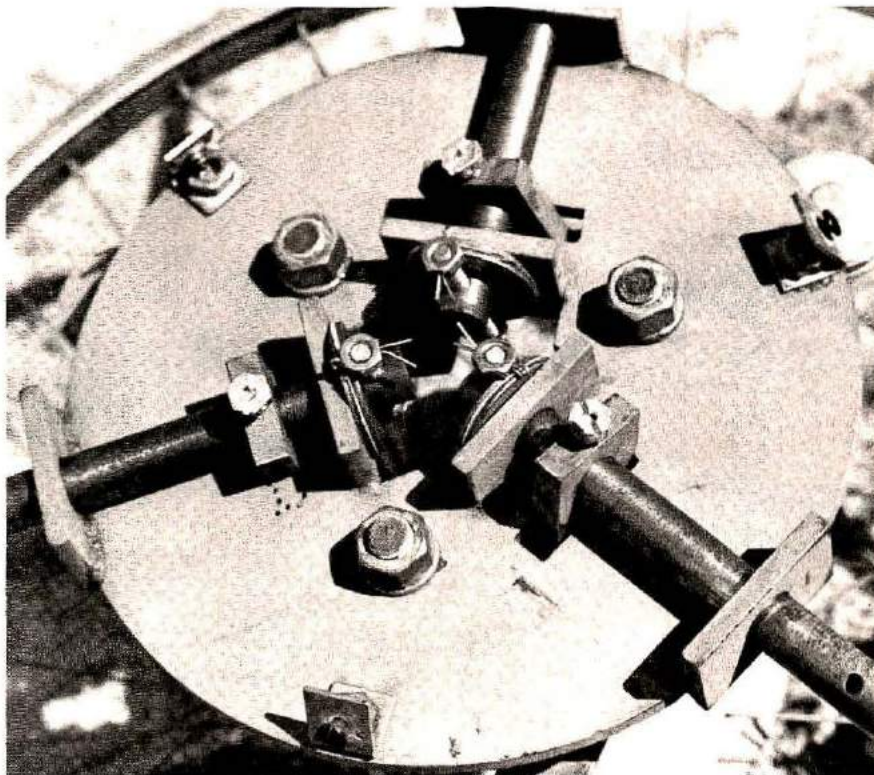
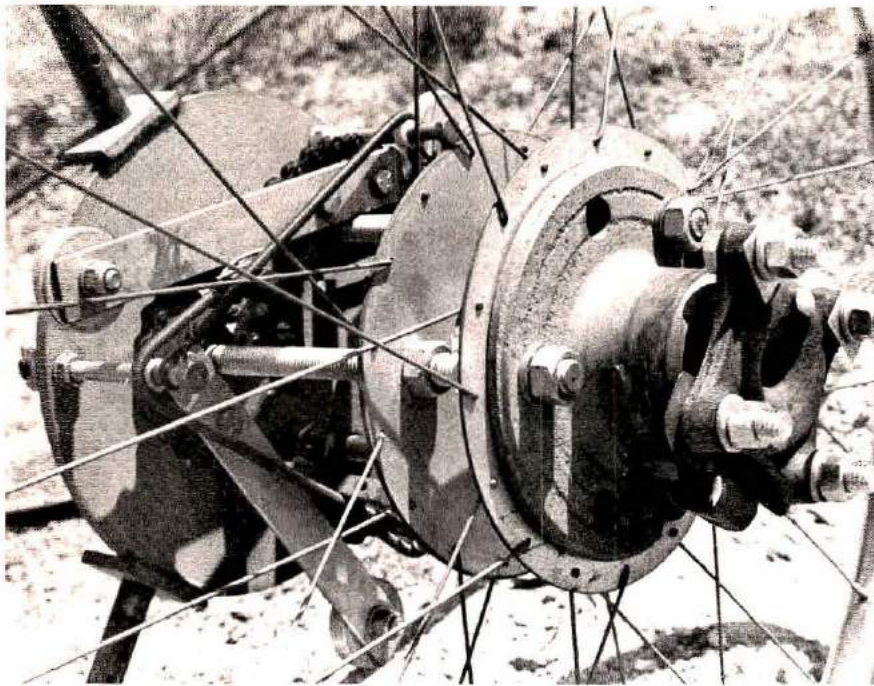

Fig. 10. The blade-support shaft is made of steel, approximately 16 mm (5/8 inch) diameter. It must fit inside the steel tubing that is used as a reinforcing strut over the length of the blade. You may have to machine the rod slightly to obtain a snug, but not pressed, fit. The rod extends approximately 34.9 cm (13-3/4 inches) into the strut.

and symmetry. It is a steel disk 22.8 cm (9 inches) in diameter, 6.5 mm (1/4 inch) thick, see Fig. 12. Three pairs of uprights (bearing blocks) must be welded to the disk at the 120-degree positions. The holes in these uprights must be carefully aligned and smooth. The rods for the blades must rotate freely, but with a minimum of play, in these holes.



The hub assembly as seen from the rear, before mounting to the channel-iron support. The automotive hub is at the right with a brush assembly to provide electrical contact across the bearing. The wheel hub has been drilled to accept three equally spaced threaded rods, which support the blade plate and feathering mechanism. Two of the three centrifugal arms, with washers for added weight, can be seen, along with a portion of the bicycle-chain drive. The bicycle spokes have been rethreaded into new hub plates which were made to fit the threaded rods. Note that the spoke holes in one plate are offset so they fall between those in the other plate (photo by W1SL).

Blade feathering

This mechanism is the secret of blade control at high wind speeds. Weights on the end of lever arms are allowed to move outward by centrifugal force,

and this outward movement is translated into a twisting motion by means of the bicycle chain and sprocket assembly.

The chain moves small levers (Fig. 14) (one on each blade shaft) to change the pitch of the blade and decrease its efficiency as the wind speed increases.

The leaning action of the levers means that the bolt connecting them to the bicycle chain will describe an arc as it moves back and forth. This arc is accommodated by allowing the sprockets to move along the threaded rod as they turn. It may be difficult to find sprockets of the correct diameter and pitch for the space available. I made mine by filing the edges of ordinary pipe flanges to accept the chain, as shown in Fig. 15. A 42-link chain is used. You do not need to form teeth around the entire circumference of the flange, but only the portion where the chain will be in contact with it. The levers are held in the low-speed position by coil springs which pass around an adjacent post and connect to the next one in order to have enough length for proper action. The weights and arms must work against this spring to feather the blades at high speeds.

The "underside" of the blades will face the wind, and they will turn counterclockwise

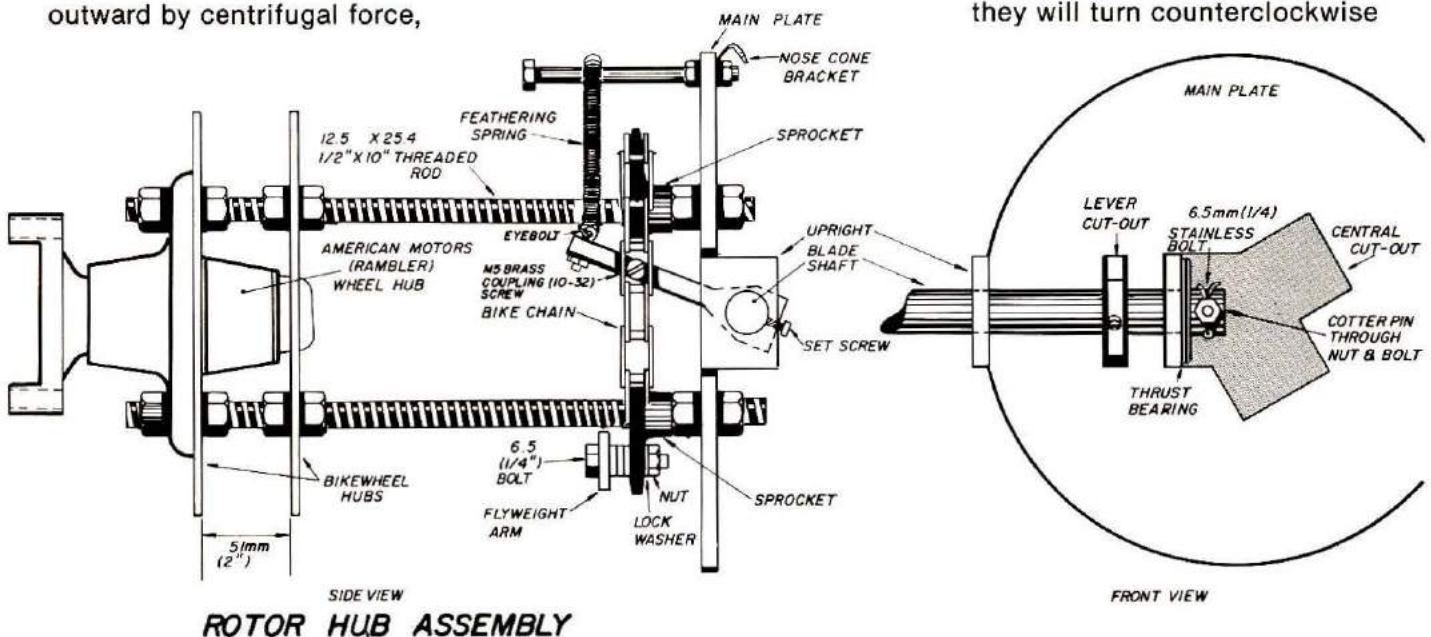

ROTOR HUB ASSEMBLY

Fig. 11. A bearing for the hub assembly is provided by a front-wheel hub from an automobile. The flange is drilled to accept three threaded rods which support the hubs for a bicycle wheel, the main hub plate, and blade-feathering sprockets.

when viewed from the front. At their resting position, with the springs just starting to offer resistance to the feathering arms, the trailing edge should be set back 6.5 mm (1/4 inch) from the leading edge.

Balance the assembly in a draft-free space that is high enough to allow the blades to turn without hitting the floor or ceiling. The tip blocks should be filed and sanded to a smooth, streamlined contour, and then varnished for weatherproofing. You can do most of the coarse balancing at that time. Final balancing can be done by adding small wood screws to the lightest blade. To make the balance more precise, use light oil on the bearings during the process, and replace the oil with a good grease before the mill is installed on its tower.

Base and generator mount

A piece of steel U-channel serves as a base to mount the mill to the vertical support and bearing. It also forms a mount for the tail assembly, the generator bracket, and holds the blade-hub assembly at the front. The channel is 61 cm (24 inches) long, and 12.7 cm (5 inches) wide. A piece of 6.5-mm (1/4-inch) steel plate is welded in a vertical position at the front and drilled to accept the bolts from the wheel hub. A hole is drilled near the center of the channel to accept the vertical bearing (another Rambler wheel hub in my case). Note that both bearing

assemblies must be bypassed with slip rings and brushes to bleed off any static electricity built up by the wind. (This is important — several cases of bearing failure have been

provides a mount for the generator also holds a piece of insulating board with brushes that transfer power to the slip rings on the vertical support. These brushes are strips of brass or bronze alloy, bent into a shallow V shape, and have blocks of graphite (replacement generator brushes will do nicely) fastened to the outer ends.

Tail assembly

A windmill needs some means of keeping it facing into the wind, and I used an aluminum vane as a steering system. The supporting structure is a leaning tripod made of thin-wall conduit, mounted on a small disk on the base channel. This disk is held in place (with the tail pointed back) by a spring-loaded locking pin. This is a safety feature that must not be overlooked. If severe winds arise, you simply pull the lanyard and

disengage the locking pin, allowing the tail assembly to rotate 90 degrees, thus positioning the windmill blades parallel to the wind and out of danger. The tail, disk, pin, and spring assembly is shown in Fig. 17. Note that the dimension from the center of the vertical support to the tip of the vane must be greater than the distance from the center of the vertical support to the tip of a blade at its outermost position. This is to ensure that the tail will control the mill as the wind shifts.

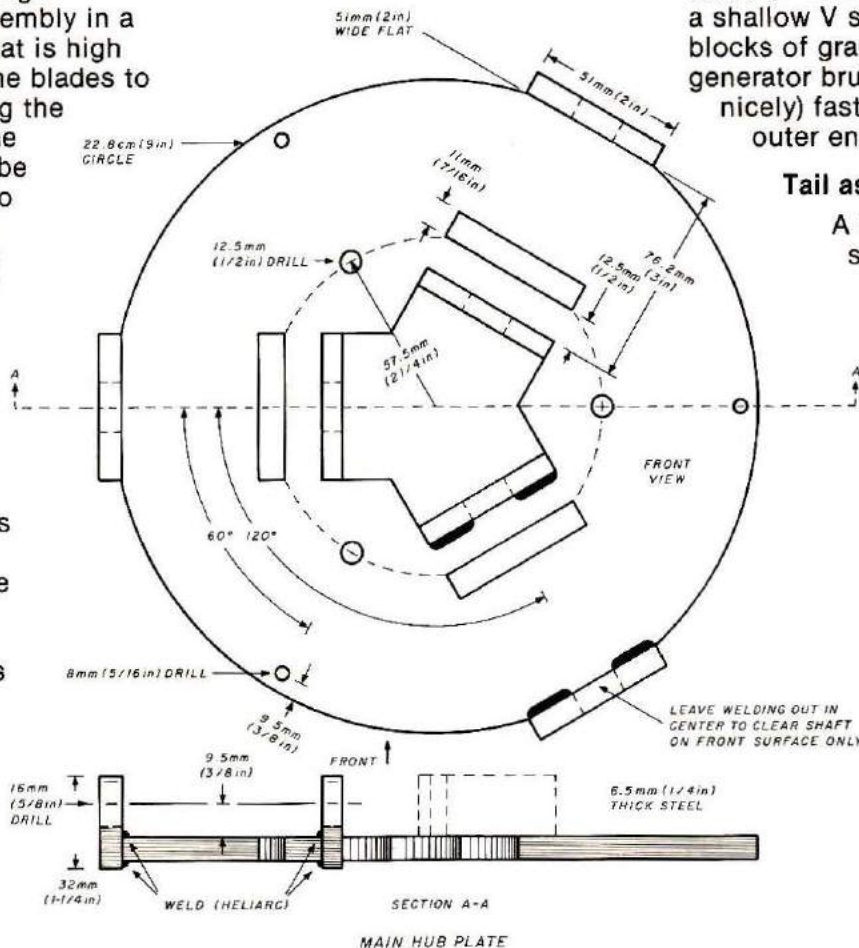
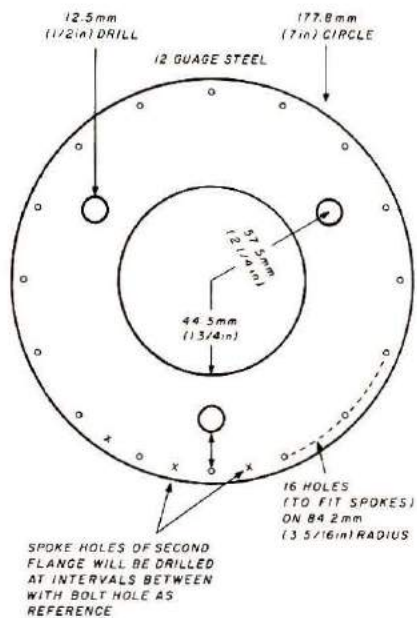

Fig. 12. The main hub plate supports the blades and provides bearing surfaces for the blade-support rods. To a large degree, this provides balance and symmetry for the blade assembly, so be very precise in welding the upright tabs and in boring the holes for the blade rods.

attributed to static buildup.)

The generator (alternator) is mounted below the base channel on two pieces of steel angle stock. Short pieces of pipe are used as spacers to align the generator pulley below the main driving pulley. Another bracket of angle stock provides a means of adjusting and maintaining tension on the V-belt to the generator. You can mount two small alternators rather than one large one, if you like — as shown in Fig. 16B.

The angle bracket that



BIKE WHEEL PULLEY HUB

Fig. 13. A new hub assembly is required for the generator-drive wheel. Holes must be drilled to accept the bicycle spokes, and also for the threaded rods from the automobile hub.

Vertical support

This section covers two areas of concern: the mechanical arrangement that holds the mill in the air, and the transferring of power from the generator across the vertical bearing assembly. For a vertical support, I used galvanized pipe and

corner of a large square tower in one installation, and clamped in the vertical support atop a triangular Rohn tower in another instance. If you use one of the popular triangular

rings to be routed inside, down to the batteries or other load to be driven by the generator. Be sure that the holes have no sharp edges, or else place insulating grommets in them to

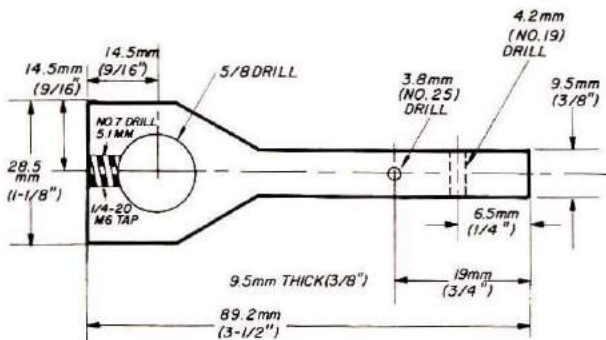

FEATHERING ARM

Fig. 14. Feathering levers clamp to the blade rods, and are connected to the bicycle chain to obtain a leaning motion. You'll need three of them.

steel towers as a support, be sure it is guyed to withstand some severe stress and vibration. Also, be sure that the top guy wires are clear of the spinning blades of the mill.

Electrical power (and field-excitation voltage) is transferred across the vertical bearing assembly by means of a set of slip rings and brushes. I found that an easy way to make the rings was to saw sections from a piece of 7.5-cm

protect the wires. The generator wiring diagram is shown in **Fig. 19.**

Testing

Before you install the generator on top of a tower, you should give it a thorough test for both mechanical and electrical performance. I mounted the blade, generator, and base assembly on a section of tower atop a van and drove at different speeds

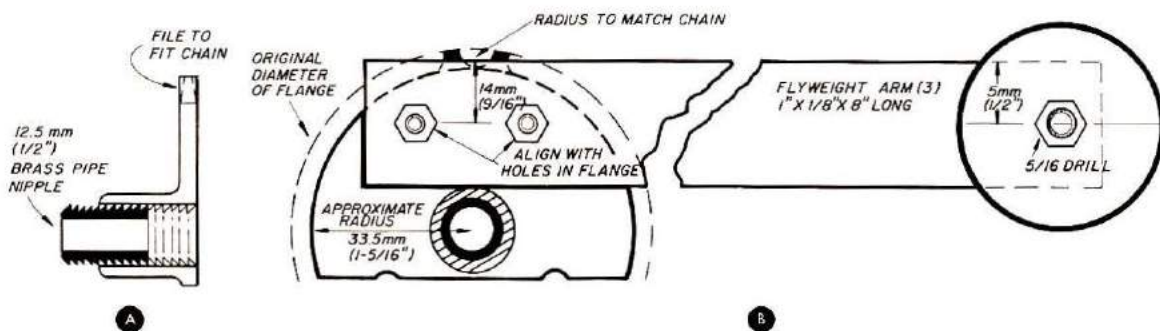

Fig. 15. Because of the dimensions of the hub assembly, I had to make my own sprockets. Pipe flanges were filed down to fit the chain, and brass sleeves were threaded into them for bearings.

welded a steel plate to the top. This plate was drilled to accept the four mounting bolts from the Rambler wheel hub. If you use a different spindle, you can make a mounting plate to fit.

The pipe was bolted to a

(3-inch) copper pipe. The rings are supported on the galvanized pipe by strips of plastic insulation such as polystyrene, Bakelite, or nylon, see **Fig. 18.** Holes in the pipe permit the wires from the slip

to check things out. If you do likewise, be sure that the vehicle will keep the mill high enough that the blades will not hit the pavement. Watch out for overhead branches and wires. And find an isolated spot to

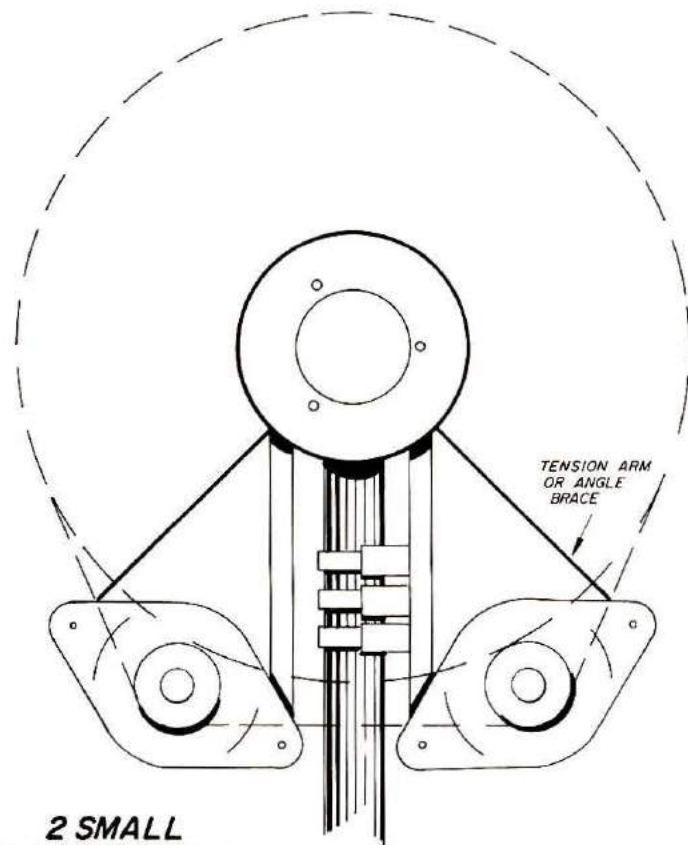
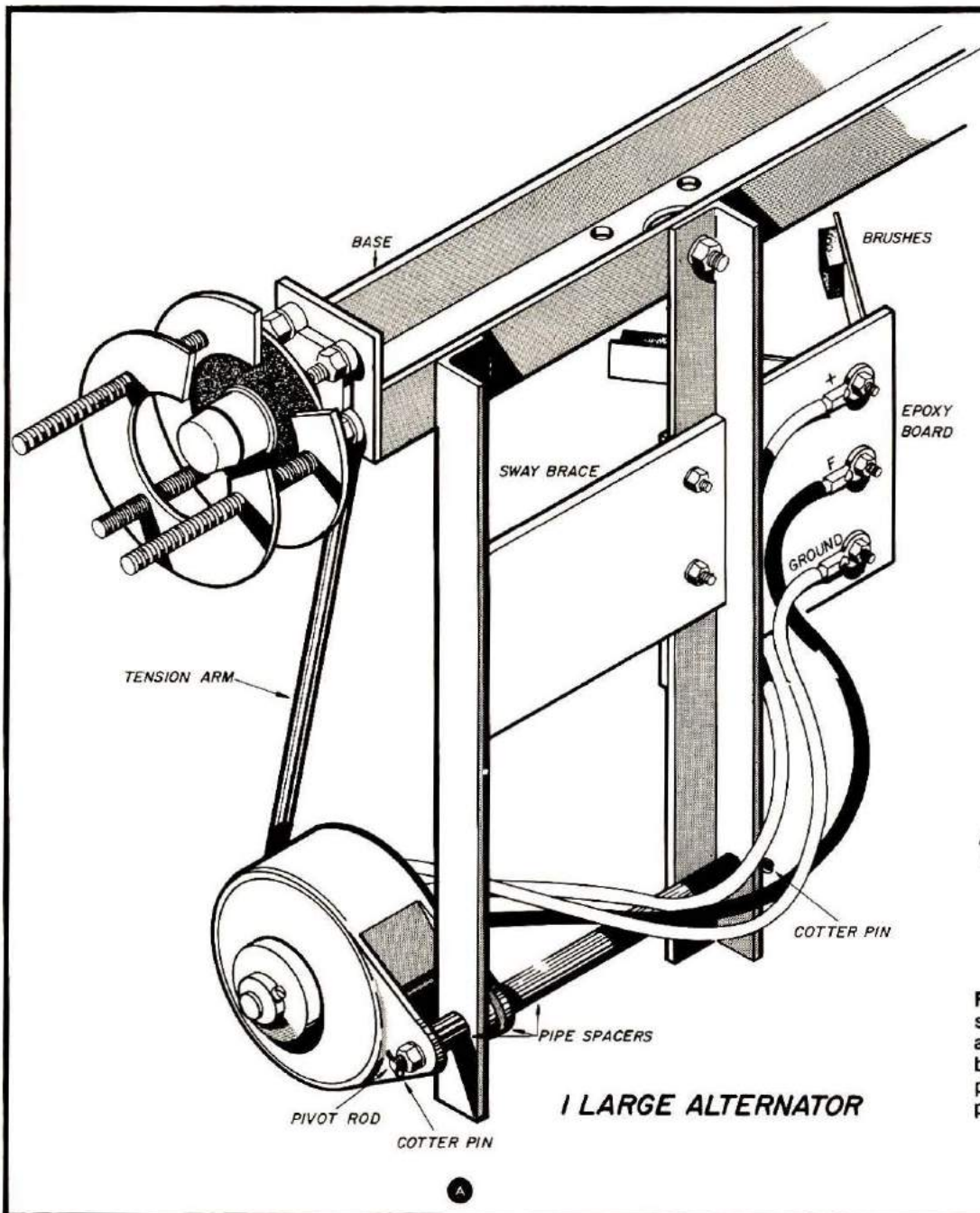

2 SMALL ALTERNATORS

ONE OFFSET 1/2" BEHIND THE OTHER FOR 2 BELTS

B

Fig. 16. You can mount one large alternator or two smaller ones, as shown. If you use two small ones, set one back 12.5 mm (1/2 inch) and use two drive belts from the bicycle rim. Threaded rod proved to be inadequate to hold the alternator in tension against the belt — a piece of angle iron, slotted to allow adjustment of belt tension, is preferable.

SLIP RINGS & MAST TOP

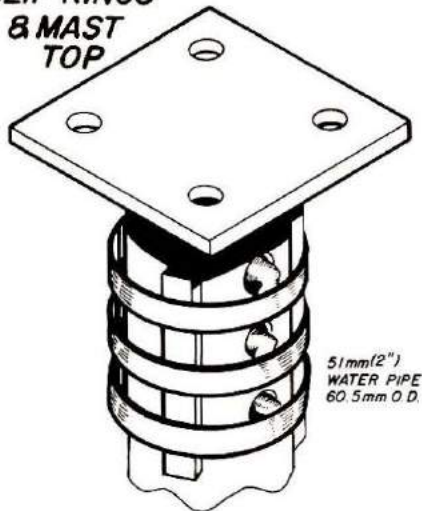

Fig. 18. A plate is welded to the top of a piece of iron pipe, and drilled to accept the bolts from an automotive wheel hub. The slip rings are held in place by strips of plastic. The brushes are mounted on a piece of insulating board behind the generator, as shown in Fig. 16. Wires from the rings go through insulated holes into the pipe, then down the tower to the batteries or other load.

drive in — this is not a project for a crowded highway. You might have to get permission to use a private road.

The load you use for the tests will depend upon how you have the generator wired. I connected the alternator so that it would provide a higher-than-normal voltage, and used a bank of automotive headlamps for the load. The lamps were arranged so that they could be connected in series or series/parallel to vary the load placed on the generator. The arrangement you build will depend upon what you want to do with the power. A standard 12-volt alternator can be used to charge a car battery, which can power a mobile or portable rig pressed into home service. If you want to use part of the output as heat or light, then a high-voltage system makes more sense. You can, of course, charge more than one battery in series. Another consideration is that a high-voltage, low-current system has lower losses caused by the

resistance of the wire, and there is also less wear on the brushes and slip rings.

As you test the generator, note the voltage and current output at different speeds. If the blade-feathering arms are working properly, the output should cease to rise at speeds above approximately 22 mph. Adjust the tension on the feathering-arm springs, and vary the weight (number of washers) on the centrifugal arms, until this condition is obtained.

Field excitation

An alternator requires an excitation voltage applied to its field winding in order to generate power. This voltage must be disconnected when the alternator is not producing, otherwise it will drain the battery between charging periods. A simple wind-actuated switch will do the job

nically. I used an ordinary hacksaw blade attached to a microswitch. A blade 25 cm (10 inches) long proved to be adequate. Wind turbulence around the top of the tower made the position of the switch noncritical, but you can try different locations to find the most reliable spot. The wind should be strong enough to keep the mill spinning at a reasonable speed before the switch closes.

Shields and locknuts

The working parts of the mill should be protected from the elements, especially where lubrication is involved. I made a nose cone to cover the feathering mechanism by cutting a half circle of flashing material and riveting the sections together. Small L-brackets serve to fasten the cone to the main spinner plate. It is easy to fashion shields for

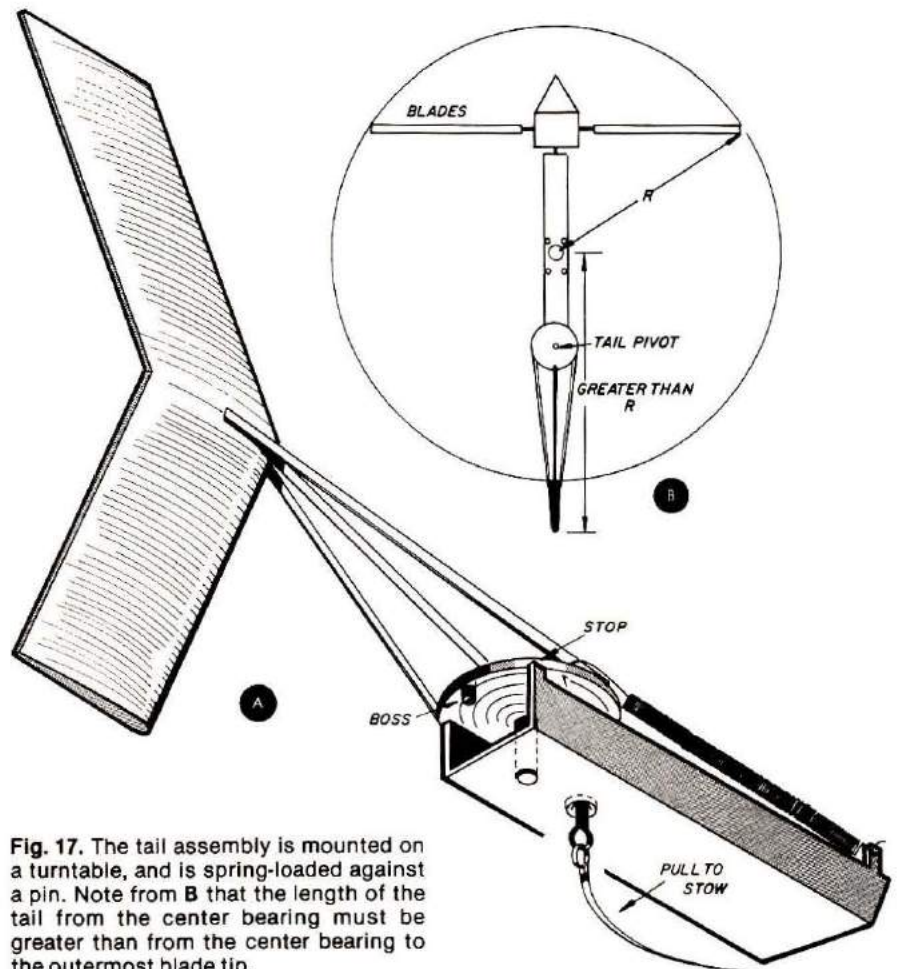

Fig. 17. The tail assembly is mounted on a turntable, and is spring-loaded against a pin. Note from B that the length of the tail from the center bearing must be greater than from the center bearing to the outermost blade tip.

the generator and slip rings from this same thin aluminum, which is readily cut with shears.

As a final precaution before installing the generator on top of its tower, check to see that everything is secure. Vibration will loosen almost anything up

there, so use double nuts wherever possible in order to lock hardware in place. In some cases, such as the generator support bolts, it would be better to drill the nut and bolt and use cotter pins or safety wire to keep them in place.

A note on personal safety —

The generator as set up on a temporary tower at the Manchester, Connecticut 1978 Field-Day site. The nose cone, and the aluminum shrouds for the generator and bearing have not been installed (photo by W1SL).

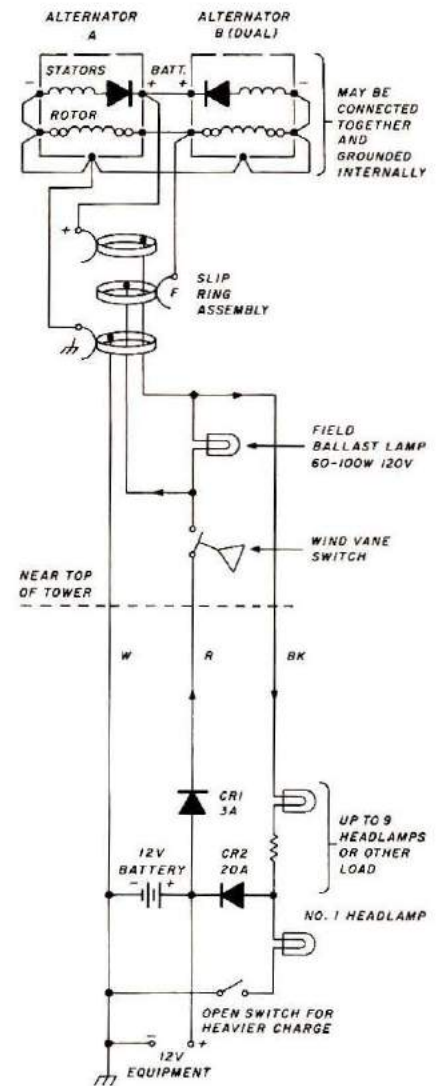

Fig. 19. The wiring diagram for the system. Two alternators in parallel are shown here, but if you use only one, just ignore the one on the right. The batteries and loads you use will depend upon the capability of your alternator and how you excite the field. More field current will provide higher-voltage output, up to the capacity of the windings and the rectifier diodes. CR1 provides initial excitation when the wind-vane switch closes, and then the ballast lamp regulates the field current. Check the wiring on your alternator before hooking it up — some have the field internally grounded and some do not.

always tie the blades in place when you are working on top of the tower. It is easy for a gentle wind to start the blades spinning before you know it. You could be severely injured, or knocked off the tower, at even modest blade speeds.

HRH

VHF	50	144	220	420
10	28.0		29.0	30.0
15	21.0			21.0
20	14.0			
40	7.0	7.1		
80	3.5	3.6		
160	1.8	1.9	2.0	

WHAT CAN YOU EXPECT

The CBer-turned-Novice is at once confronted with the delicious choice of operating on one or more Amateur Radio bands scattered throughout the high frequency spectrum. Each band has its own characteristics and peculiarities and, historically, ham operators have tended to congregate on one band or another, finding other hams of similar interests. The Novice starts out on CW, operating within certain restricted bands set aside just for him; but let's look at what happens when Novices go on to become Generals, and the whole wide world of Amateur Radio stands before them.

The HF bands — 160 to 6 meters

The 160-meter band (1800 to 2000 kHz) is really the oldest amateur band, and most Amateur Radio activity was concentrated in this region in the early 1920s before the long-

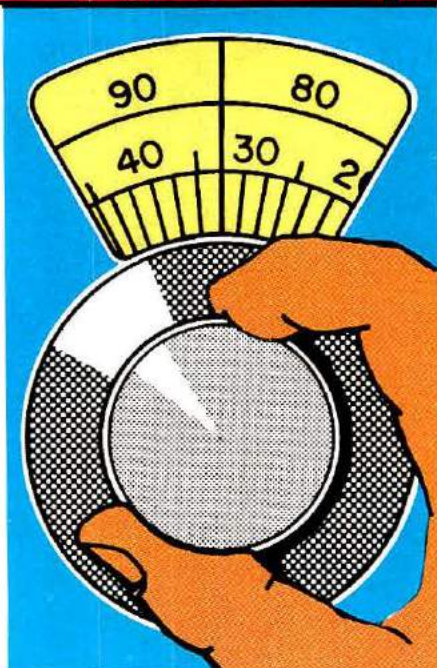

BY WILLIAM I. ORR, W6SAI

Your interest in Amateur Radio will lead you, in time, to many different bands. What will you find there, and how can you make the best use of them? This overview of the Amateur bands from 160 meters to 24,000 MHz will help you decide.

FROM THE HAM BANDS

distance capabilities of the higher frequencies were discovered. In the United States and Canada today, the 160-meter band is divided on a regional basis into eight 25-kHz segments, with various day-night power input limitations and restrictions imposed, depending on the region and the time of intended operation. The permitted power input to an amateur transmitter in the 160-meter band ranges from 25 to 1000 watts. Amateur operation is segmented in this crazy-quilt fashion because the band is shared with LORAN (Long Range Navigation) stations operated by the United States Coast Guard. Amateur operation is restricted in power and area of operation with respect to LORAN stations, which are located in the Great Lakes area, along the eastern and western seaboard of the United States, and in Hawaii.

Generally speaking, the 160-meter band is considered a

"rag-chewer's" band, and supports many CW and ssb nets and round tables. At night, especially in the winter months, the 160-meter band offers some good DX possibilities, with frequent transcontinental and transoceanic QSOs (contacts) taking place.

LORAN stations emit a series of high-power pulses that sound like a buzzing noise to the casual listener. Most hams steer clear of LORAN stations, even if they are distant, because reception through the racket is difficult. This band is a "sleeper," but once more is gaining in popularity and slowly coming to life as more equipment for 160-meter operation becomes available. There is also the possibility that someday LORAN may be greatly reduced or eliminated entirely, and the entire band returned to the amateurs for their exclusive use — a happy day for most old timers. Unfortunately, at present, no Novice privileges exist in the 160-meter band.

The 80-Meter band (3500 to 4000 kHz) contains the Novice sub-band of 3700-3750 kHz. Many Novices "cut their teeth" in this band, which is often full of QRM (interference) caused by the large number of stations that operate there. Daytime operation is generally limited to contacts of 500 miles or less, but as the sun sets and radio conditions change, long-distance DX contacts are quite common, especially during the winter night hours. During the summer months the 80-meter band, like the 160-meter band, has a high static level, and poor radio conditions limit long-distance contacts. But when radio conditions are good, stations from all over the world may be heard on the 80-meter band. The top portion of the band (3775-4000 kHz) is reserved for phone operation and many sideband (ssb) signals may be heard here at all times of day or night.

Because of the interference created by large numbers of stations operating in the Novice band, many Novices go to bed early and get up in the early morning hours when the band is relatively quiet — to enjoy their contacts while many of their fellow amateurs are still "in the sack."

There's also a lot of non-amateur interference in the 80-meter band. European shortwave broadcast stations can be heard during the winter months near the top of the phone band and often foreign fishing boats operate both CW and ssb at various spots in the 80-meter band. So you'll have a lot of company in this popular amateur band — and some of the company you may not like!

The 40-meter band (7000 to 7300 kHz) contains the Novice sub-band of 7100-7150 kHz. The 40-meter band is high enough in frequency to be called a DX band, although plenty of local contacts take place on this band during the daylight hours. DX operation, however, is severely hampered on the 40-meter band by broadcasting stations and jamming transmitters. In other regions of the world, the range of 7100-7300 is shared between shortwave broadcasting and amateur stations. In addition, many broadcast stations have moved lower in frequency, nearly to the 7000-kHz edge of the band. As a result, the whole band is a mess during the evening hours. In areas of Europe and Asia, the 40-meter band is either restricted as far as ham operation goes, or is unusable because of the chaotic interference (QRM). As a result of an international frequency conference some years ago, international broadcasting was permitted in the 40-meter band, and that band has become of less value to the amateurs because of this shared service.

In spite of the racket, plenty of DX can be worked on the 40-meter band. The top portion (7150-7300 kHz) is reserved for

phone operation and you'll hear plenty of ssb signals in this region at all times of day and night. Look around 7200 kHz for ssb DX signals popping up from all over the world during the cooler months of the year.

The 20-meter band (14.0 to 14.35 MHz) is the most popular band for DX work. Right now, the band is open to almost all parts of the world at some time during the year. During the summer months, the band is active until the late evening hours, but during the winter months the band closes down at sunset. During the spring and fall months, the band often opens over the *long path* with signals arriving from a direction 180 degrees opposite to their normal direction of arrival along the Great Circle path. For example, Australian stations can be heard on the East Coast in the afternoon hours as they arrive after travelling over Africa and the Indian Ocean. And on the West Coast, European signals can be heard as they arrive by way of Australia. Long path DX also occurs on 40 and 80-meters, but it is more elusive and takes considerable skill, high power, and a good antenna to take advantage of this mode of communication. On 20 meters it is quite commonplace and gives beginner and old timer alike a big thrill. Unfortunately, there's no Novice band on 20 meters. Hurry up and get your General ticket and join in the fun!

The 20-meter band is the DX band where beam antennas become popular. Forty and eighty meter beams are very large and usually out of the question for the majority of operators, but the 20-meter Yagi beam has a "wingspan" of only about 36 feet (11 meters). The quad beam, moreover, is even more compact, being only about 16 feet (5 meters) on a side. Unlike CB radio antennas, high frequency radio amateur beams tend to be horizontally polarized, whereas vertical

polarization is used by the majority of CBers.

The 15-meter band (21.0 to 21.45 MHz) contains the Novice sub-band of 21.1-21.2 MHz. This long-distance DX band has more erratic characteristics than the 20-meter band. During certain years, particularly during the fall and spring months, the 15-meter band is alive with DX signals, arriving via both the long and short Great Circle routes. During some years, when sunspots are numerous, the band may remain open for DX 24 hours a day, particularly in the southern part of the United States. At the present time the sunspot cycle is on the increase, and conditions will be excellent during the winter 1978-79 DX season.

At certain times of the year, north-south radio conditions are particularly good and South and Central American stations boom in with amazing signal strength. During the summer the 15-meter band supports quite reliable communication out to 1500 miles (2500 km) or so, particularly during the late afternoon hours. However, as the home-town rooters say of a losing football team, "Wait until next year!" Radio conditions are predicted to improve, and by 1979 the 15-meter band should be a Novice's delight, with DX stations from all over the globe booming in like locals!

The 10-meter band (28.0 to 29.7 MHz). Within the 10-meter band is the Novice sub-band of 28.1 to 28.2 MHz. The 10-meter band is not far removed from the CB channels and radio conditions at 10 meters are similar to those on the CB 11-meter range. Right now, DX signals are improving, and the winter 1978-79 season should see the band jumping. Under better radio conditions, the 10-meter band is without doubt the most popular DX band for radio

hams. The great width of the band (1700 kHz) provides room for a large number of radio amateurs, and the long skip distance prevents nearby amateurs from hearing each other, thus dropping the overall interference level. The 10-meter band is the poorest in the summer months, aside from those intermittent short-skip conditions already noted for both 11 and 15 meters. During the coming years, the 10-meter band will come to life and support intercontinental DX during the evening hours.

The "top end" of the 10-meter band is specialized in that fm signals are allowed to operate here, and the output channels of the OSCAR space satellite for Radio Amateurs fall in this region.

During the "ups" and "downs" of radio conditions, the 10-meter band supports a number of local rag-chew nets, and you can easily spot these as you tune across the band. An increasing number of Novices are using the 10-meter band as they become aware of the interesting possibilities this chunk of spectrum presents.

It should be noted that the second harmonic of stations operating in the 10-meter band falls directly into television channel 2, and the higher harmonics of the transmitter fall into the higher TV channels.

Amateur Radio equipment operating in the Novice 10-meter band, in particular, can produce severe television interference on some sets if the equipment is not properly shielded and filtered. The subject of television interference (TVI) will also be covered in a future article. Suffice it to say that the problem of TVI can be greater in the 10-meter Novice band than it is in the other Novice bands.

The 6-meter band (50.0 to 54.0 MHz) was created from what was to have been TV channel 1.

This channel never came into use, so the spectrum for it was assigned to the Amateur Radio Service. TVI can be severe for hams working on 6 meters, because the band is cheek-to-jowl with TV channel 2 and uncomfortably close to channel 3. Most hams crowd up at the low end of 6 meters so as to be as far away from the TV channels as possible.

In addition, in areas where channel 2 is in operation, a considerable amount of "spillover" from the television transmitter invades the top end of 6 meters, sounding like a raspy buzz-saw. This wipes out a lot of the 6-meter band in some areas of the country, leaving only the bottom portion of the band (near 50 MHz) clear enough for radio communication.

Normally, the six-meter band is considered to be good only for *line of sight* communications, but enough long-distance DX contacts have been made to indicate that unusual modes of propagation seem to flourish in this portion of the spectrum. Future issues of *Ham Radio Horizons* will carry articles outlining these interesting and useful means of long-distance communication that make the 6-meter band interesting to newcomer and old-timer alike.

The VHF bands — two meters and up

The very high frequency (vhf) amateur bands represent a new and interesting world for the Novice newcomer. At the present time, no assignment for Novice operation in these bands is available, although this may be modified sometime in the future.

Of the vhf bands, the most popular one is the 2-meter band (144-148 MHz). The top half of the band is occupied by the world of fm (frequency modulation). Vhf *repeater* stations, located on high ground around the major cities of the United States (and other

Frequency Spectrum Chart

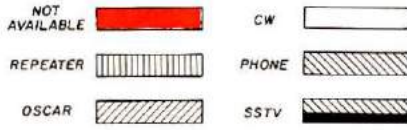

TECHNICIAN LICENSEES have privileges of all Novice frequencies and General frequencies above 50 MHz.

CW permitted on all frequencies available to that license

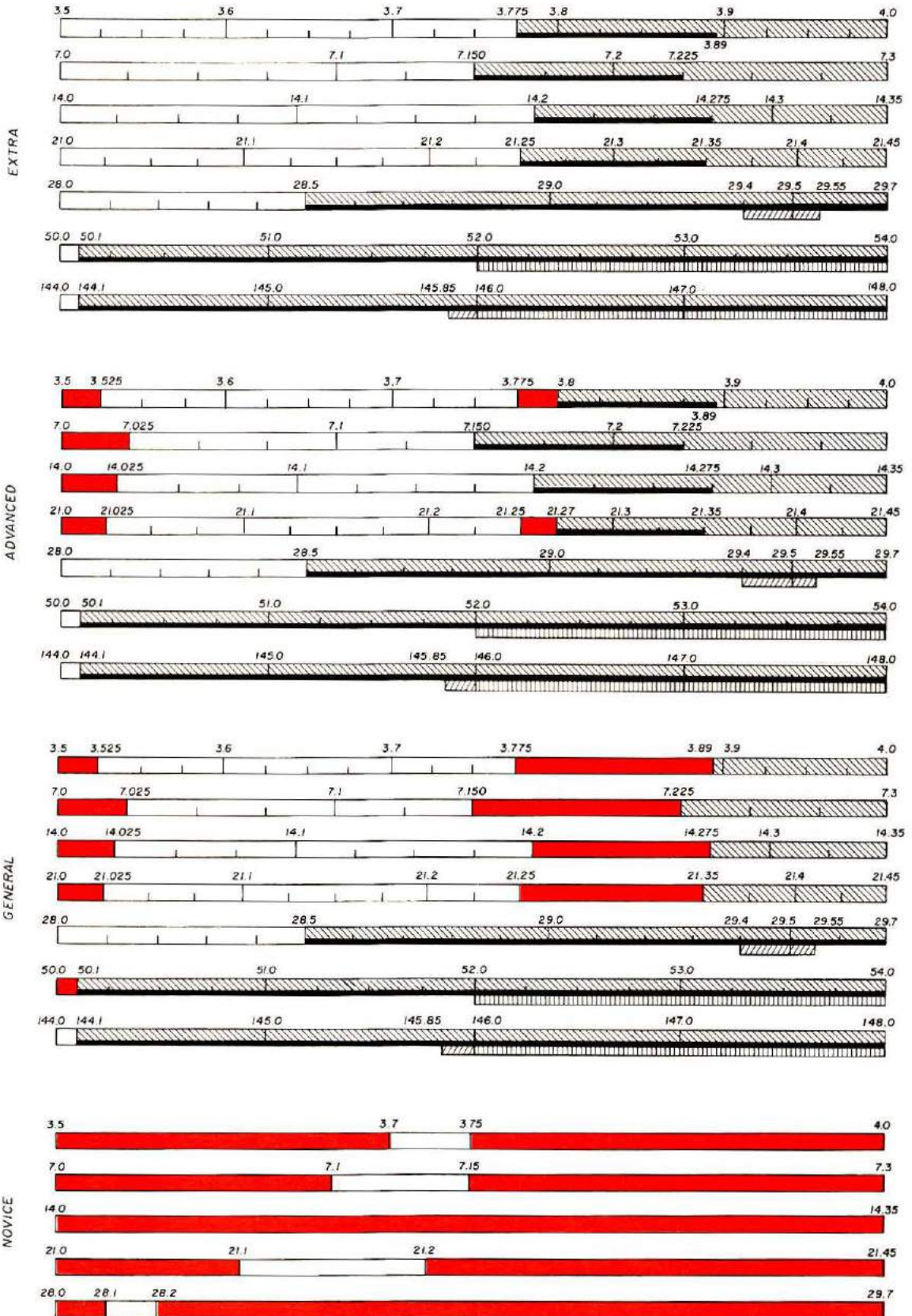



It's easier

Dx'er
Contester • Trafficman
Ragchewer

Telex headphones and headsets make it easier to enjoy the hobby. Whether you prefer lightweight or full cushioned comfort, there's a high performance Telex product that will help make you a better operator. See yours...at better ham outlets everywhere, or write...

PRODUCTS OF SOUND RESEARCH
TELEX
COMMUNICATIONS, INC.

9600 ALDRICH AVE. SO., MINNEAPOLIS, MN 55420 U.S.A.
Telephone: 612-884-4051, telex: 29-7053

Europe: 22, rue de la Legion-d'Honneur, 93200 St. Denis, France.
telephone: 820-98-46, telex: 63-0013

countries) provide instantaneous and automatic relay points for both mobile and fixed stations. Operation is channelized, much as in the CB region, and each repeater may have hundreds of users. Some repeaters are restricted as to who may use them, and others are used for other means of transmission than voice. But most of the repeaters are available to all users as a common mode of communication, and the 2-meter band in large metropolitan areas is alive with the voices of amateurs.

At the low end of the 2-meter band can be found a small group of experimenters who communicate with each other by bouncing their signals off the moon, or off ionized meteor trails! Amazing as it may seem, intercontinental communication is carried on by moon reflection on the 2-meter band, which is normally thought of as a short-range communications band! Some amateurs are active on 2-meter single sideband (ssb) and others communicate through the amateur Oscar space satellite which functions on this band. Occasionally, unusual weather conditions permit direct vhf communication over distances of 1000 miles or so. Once thought of as a local band, the 2-meter band is proving to be extremely versatile, and new discoveries of its capabilities are being made every day. For the newcomer to Amateur Radio, the most outstanding characteristic of the band is the fm activity and large number of repeater stations that dominate the top portion of the band.

Higher in frequency than the 2-meter band is the 220-225 MHz amateur band. (At these frequencies the "meters" designation has been dropped). This band is shared with radar in the United States and, in certain areas of the country, "spillover" from radar makes the band a buzzing headache. Generally speaking, the

characteristics of the 220-225 MHz are much the same as those of the 2-meter band. There are many fm repeaters in this band and most communication is of the short-range variety. In the future, the possibility exists that a portion of "220," as it is called, may be turned over to the Citizens Radio Service for expansion!

Additional vhf bands exist above the 220 MHz band, all the way up to 24,000 MHz! The so-called "450 band" (420-450 MHz) is popular for experimenters and widely used for amateur fm, television, and moonbounce communication. Since a whole issue of *Ham Radio Horizons* could be devoted to "450" and the higher bands, it will suffice to say that the future of Amateur Radio surely lies in this fascinating portion of the spectrum. Plenty of surprises await the amateur who ventures into these unusual and rewarding slices of the communication spectrum.

Justice cannot be done to the amateur bands in such a short review but, in conclusion, each band has merits and wonders of its own. To the Novice amateur I say, "Get your Technician or General class license and come on in, the water's fine!" **HRH**

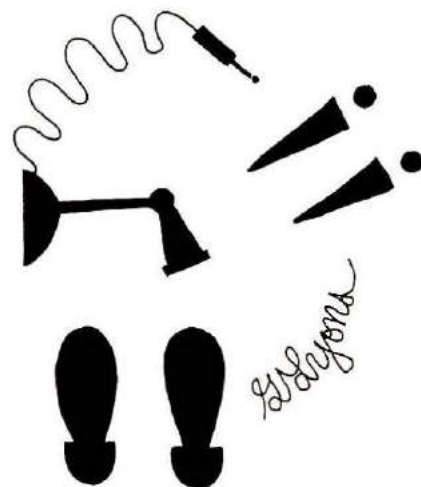

"Yes, dear, you have a dead mike, but it's not necessary to notify the coroner!"

WHERE RELIABILITY & ACCURACY COUNT

INTERNATIONAL CRYSTALS

70 KHz to 160 MHz

HOLDER TYPES

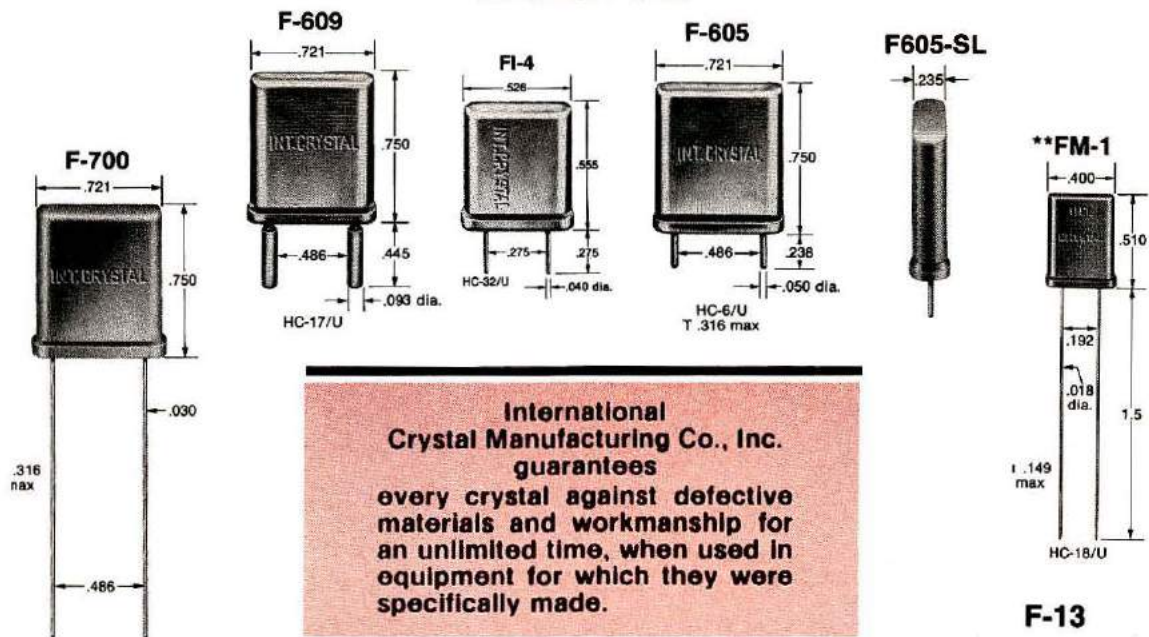

**International
Crystal Manufacturing Co., Inc.
guarantees
every crystal against defective
materials and workmanship for
an unlimited time, when used in
equipment for which they were
specifically made.**

CRYSTAL TYPES

- (GP) for "General Purpose" applications
- (CS) for "Commercial" equipment
- (HA) for "High Accuracy" close temperature tolerance requirements

International Crystals are available from 70 KHz to 160 MHz in a wide variety of holders.

WRITE FOR INFORMATION

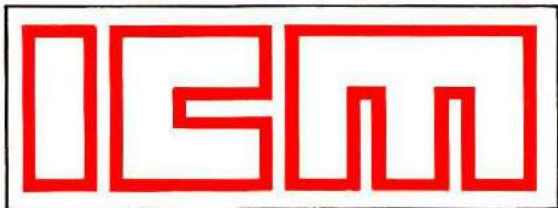
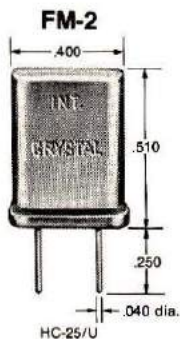

INTERNATIONAL CRYSTAL MFG. CO., INC.
 10 North Lee, Oklahoma City, Oklahoma 73102
 405/236-3741

Signals from SAFARILAND

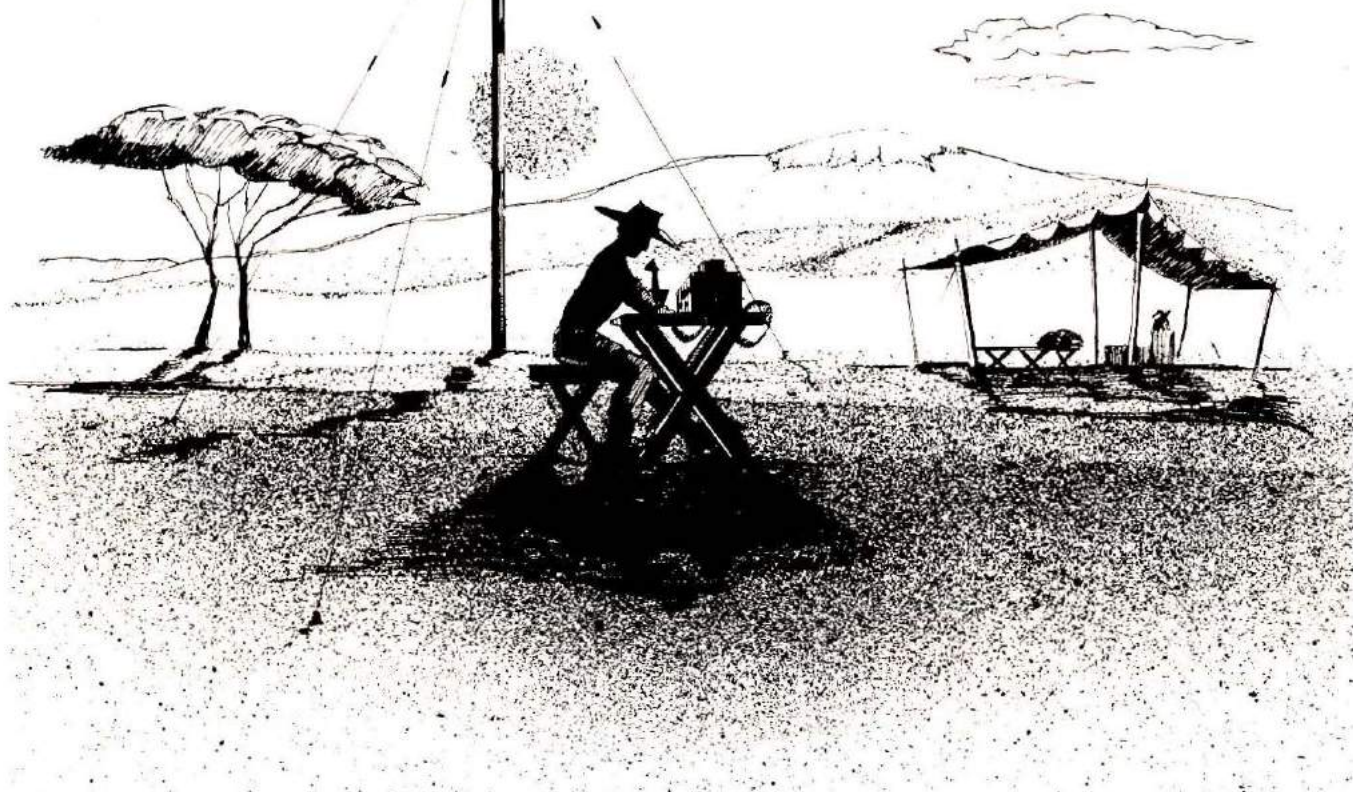

BY N. STEVEN-HUBBARD,
ex-VQ4NSH

The year was 1947 and the place was the great rolling plains of East Africa. To the southeast were the low mountains of Ngong, while directly south, nearly one hundred miles away, could be seen the dramatic protrusion of Kilimanjaro Mountain, rising thousands of feet from the wide plain of Masai country. This was the sand-colored plain with patches of washed-out green, waterholes, and streams vital to the herds of animals that populate the area.

There were thousands of zebra, wildebeest, antelope of several varieties, and an occasional pride of lion. On a small hill in this rather ordinary African landscape, an American-made box-body car (station wagon) was standing only a dozen or so yards from six young lions and three adults, all of them in mixed attitudes of rest and play.

Had you observed the car more closely, you would have seen that it was a little unusual. The car had a tubular metallic structure on the roof, and, even more surprising, a thin wire rose vertically from

the rear window for at least two hundred feet. At the upper end of this wire was a large, but flimsy-looking, balloon. One of the two people in the car was talking into a microphone at intervals, while another voice seemed to be coming from behind the rear seat. The voice was accented in tones that were clearly not native to a British colony, but would be right in place in New York City.

"Good-night Pete, you had better get some sleep — it must already be tomorrow in Manhattan. This is VQ4NSH standing by for other W calls. From sunny Africa, this is

VQ4NSH calling CQ."

Needless to say, I was rarely passed up for that kind of romantic contact and I suppose that I must have had literally thousands of contacts with United States amateurs in the few years between the end of World War II and 1953, when I finally left Africa to come permanently to live in America.

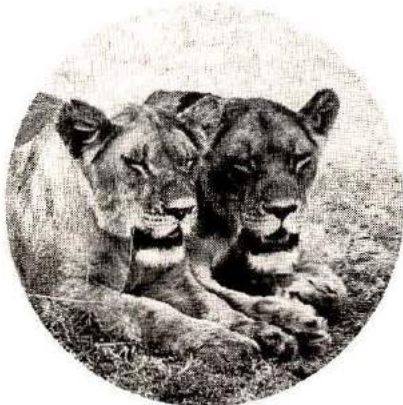

I had gone to Africa as a young man before the outbreak of the European war, to serve with the British Colonial Government. I later spent fifteen years in Kenya, Uganda, Tanganyika, and other nearby territories, gaining an intimate knowledge of the lands, languages, and peoples of this exotic part of the world.

I can best illustrate the remoteness of this land by the address on a QSL card I once received. The fact that I received it at all is a tribute to the persistence of the post offices involved. It was addressed to my name and my call sign at "Nairobi, Bombay, South Africa."

African unity

Before most African areas became independent of the Colonial powers, the people were tightly integrated into units whose major loyalties were to tribal institutions, but with only weak attachments to the idea of national government. The Colonial government's main task was to extend these tribal aims toward the concept of national unity.

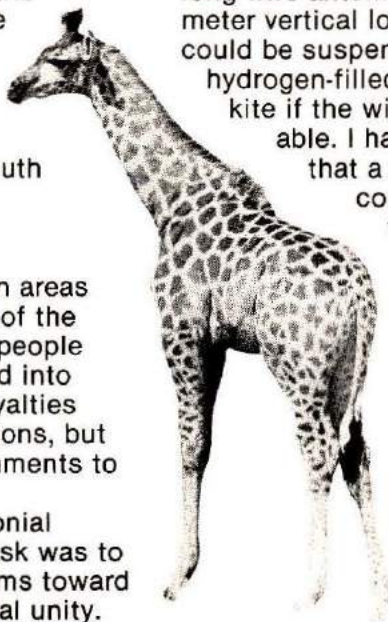

This turned out to be a task of enormous difficulty, and one which was only minimally successful, as can be so clearly seen in the recent histories of nearly all African nations. Things like rail transport, medical and health services, tele-communications, and postal services are not limited to single territories. Thus, these and other technical services can be unified for several contiguous areas; my work in my last period of service was to build the tele-communications network of the East African territories. Eventually, I directed the training of people to operate and expand the system. In 1947 we designed and built an inter-racial technical college for this purpose.

The station

One of the non-Government activities that was generated at the site of this institution was radio station VQ4NSH, both base and mobile. The "box-body" (local term for station wagon) was fitted out exclusively with gear modified from United States ex-military equipment. VQ4NSH mobile, when fully operational, had three separate transmitters on 40, 20, and 10 meters, two HRO receivers, a two-element 10-meter beam, several portable long-wire antennas, and a 40-meter vertical longwire which could be suspended from a

hydrogen-filled balloon or a kite if the wind were favorable. I have to report

that a number of DX conversations suffered at times

due to wind failure, but I will say that if you know that your antenna is likely to fall around your ears at any unpredictable moment, the efficiency of information

passing is remarkably high, and the air waves become less cluttered with asinine verbiage!

Each transmitter supplied about thirty watts of rf power when operated from a 24-Vdc base pack which could be selectively switched for series or parallel connections, thus using the car's 6-V generator



for primary energy. The surplus 24-28 V equipment was great for this purpose. I also had another, rather small, 10-meter transceiver in the front compartment, the transmitter of which would put out no more than three watts. Hooking this up to my beam and using the two HRO receivers in duplex with two antennas, I regularly worked Europe, North America, and Australia with usually good signal strength.

The life style of a senior officer in that African Colonial service at that time was very demanding. We worked and played hard and our lives were full, exciting, and rewarding. We felt we filled an important function in the future development of the new Africa.

I had a roomy house on a hill, and my amateur station was in one wing. I had a number of transmitters and receivers and an antenna farm with beams, a quad, and a couple of rhombics. The transmitter power allowed by our government was 150 watts, but the remote location and optimum topography more than compensated for power restrictions. A four-wavelength stacked rhombic forty feet in the air on a prominence, with the nearest static generator

twenty miles away, constitutes almost ideal transmitting and receiving conditions, especially when you are already at six thousand feet above sea level! Any kind of signal defect was attributable only to conditions in the ionosphere; as these years were periods of high sunspot activity — and therefore of well-behaved refractive ionizing layers — even this condition was in our favor. There were never more than a dozen active hams in the whole of East Africa, so we had no need to compete with each other for band space, and no irate neighbors complaining about parasitic signals interfering with baseball games.

Actually, the only part of the total population that had the remotest interest in baseball were the few Americans and the United States Consulate in Nairobi, with whom I had made friends quite early on, and to whom I was able to be of some help. It is very easy for sophisticated people of the Western world to feel completely lost and confused when they are precipitately thrust into a world so different from our own. Often, the outcome is immediate and severe culture shock. It was easy to help alleviate some of this distress among my American friends by arranging contacts with their relatives and families. One such instance was particularly satisfying.

A Thanksgiving success

My wife and I had heard from our friends about the occasion of Thanksgiving and had recognized the overtones of nostalgia in our friends' enthusiastic description, so we planned a surprise for some of them. We made some discreet inquiries, requiring detective

work and some subtle questioning. We found out home addresses and names and made some very specific area calls, like "CQ Rochester, New York," and planned a very specific rendezvous. We did this for three different stations and crossed our fingers for an active ionosphere on the right day. We also talked to one of our best friends in New Jersey, and the ladies had long sessions on rather special recipes. Some of these were new to us, but we rallied around with a few friends in the restaurant business and got our cook-in-training to set up a "real" American Thanksgiving dinner party. The dinner was a great success and, over coffee, I casually asked everybody if they had ever seen an amateur radio station in operation. We moved into the "shack" and I casually made a call, five minutes before our very carefully organized rendezvous, to check band conditions; they were excellent!

When I called Rochester, and the Economics Councilor discovered that his wife and two daughters were on the other end of the transmission, you can imagine everybody's delight. After similar success with calls to Miami and Chicago, the evening was voted a tremendous success — and I am sure I made some friends for our fraternity as a consequence.

Of course, there were other occasions of this kind, one of which had a delightful sequel. A year or so after our reputation had been made with the United States Consulate, MGM from Hollywood arrived in Kenya to shoot parts of one of their spectaculars called *King Solomon's Mines*,

and we got somewhat involved in this. We got to know not only some of the characters in the movie, but, of greater interest to us, some of the people who do the film work. The chief of photography, Robert Surtees, was one of them, and he turned out to be a well-known ham in his home area.

I remember that they were having trouble getting word back from the home studios concerning the color density and sound level of their test films, and were worried about their schedules because of this. I offered them the use of my station and they got direct information right out of their color and sound labs; this made them very happy. Four years later we were in Hollywood and spent several good days there with Bob and his family — my daughter got to



The country and the people

The equatorial areas of Africa — from the lowland coasts to the high uplands where permanent snows cover the mountain tops — are not heavily populated. When we first travelled in the far west of the United States and Canada, we constantly remarked how much it reminded us of the highlands of central Africa. Of course, the real contrasts exist in the people. Not that people, whoever they are, vary significantly in their fundamental characteristics, but they do exhibit a bewildering array of styles for expressing these characteristics. We, who are so deeply immersed in technical paraphernalia and our knowledge of the ways in which our world

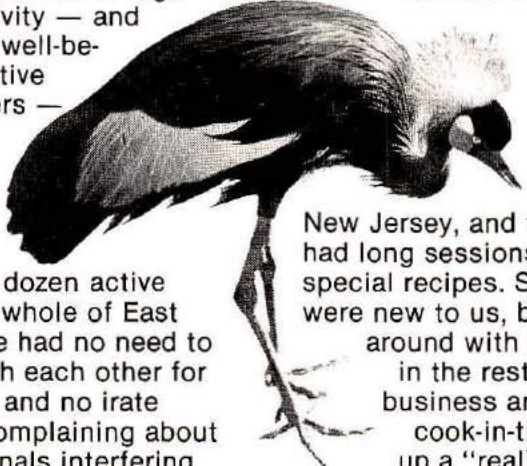



Gedi ruin — Kenya coast.



Kihaya household — near Bukoba Tanganyika.



Mount Kenya from Teliki Valley.



Little Simba Tarn — Mount Kenya.

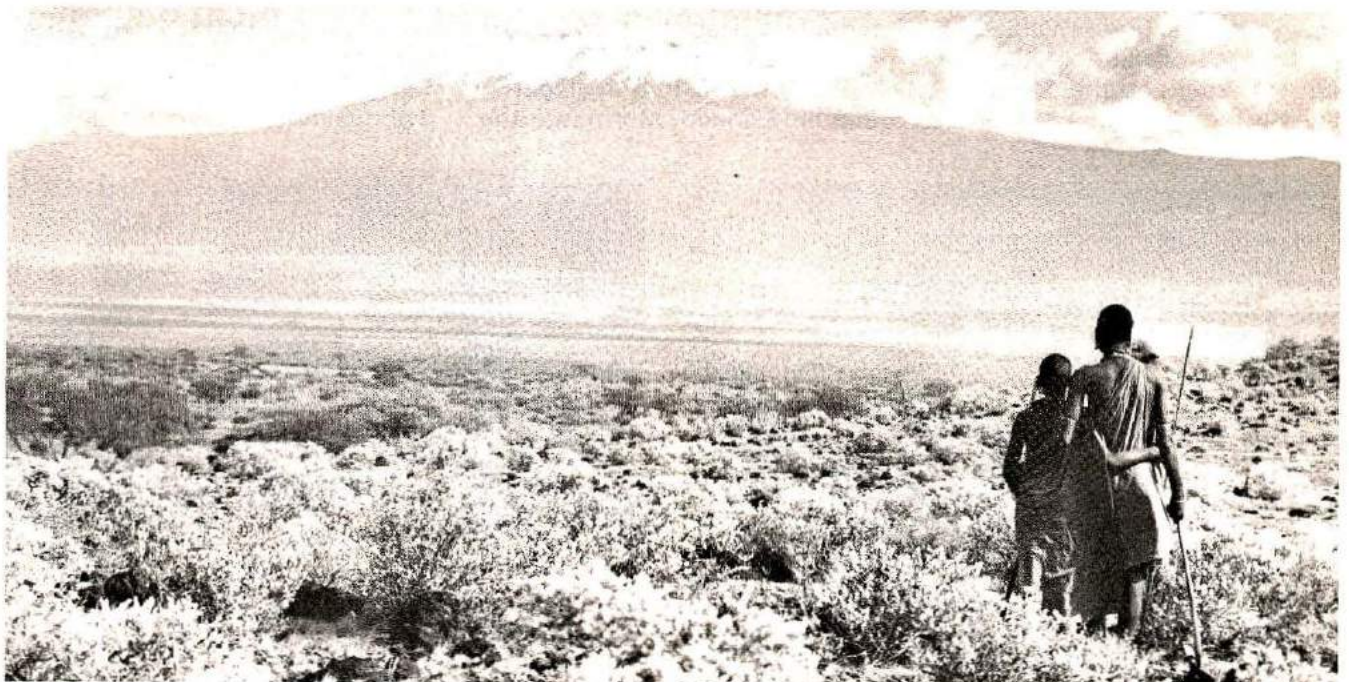

The awe-inspiring Mount Killimanjaro could be seen rising from the Masai plains.

VQ4NSH mobile made use of a 1936 Ford station wagon. It had a ten-meter beam attached to the roof, and a vertical long-wire sometimes held up by a balloon. Over 100 countries were worked from this rig; some contacts were made while using as little as 1 watt.



works, find it hard to understand and have much sympathy for people whose ancestors were never touched by Western history.

This simple fact arose from geography and can be easily understood by a careful look at a global atlas. Few of us recognize our enormous good fortune in being a part, because of a lack of physical barriers, of the mainstream of human interaction for a very long time; certainly for several hundred generations.

I have found that, rather than invent complex explanations for the "strange" behavior of native peoples, it is more rewarding to recognize reality.

Raids and raiders

The life-style of Africans in their usual setting of village, or, in the case of the nomadic cattle herders on the constant search for grazing, is hard,

demanding, and often more than a little uncomfortable; it is also at times highly competitive for limited resources. For example, the Masai, who are reputed to be descendants of the ancient Egyptians, live among, for, and on, their cattle — quite literally. They sleep among them, they use them for money, and they drink their blood. Masai cattle are not a bit like Borden's Elsie, though. They are small, tough and long-horned, but they do die of disease and drought. When the herds get depleted, the Masai suffer severe depression and don't eat very well. So much for the "happy children of nature."

Under these rather trying circumstances, every few years a kind of crusade is arranged and the Masai warriors, who have already proved their manhood by killing a full-grown lion while armed with only spear and hide shield, storm into the

territory of another tribe, usually the Kikuyu, to steal hundreds of cattle and dozens of women. Of course, those attacked resist with vigor, and people not only get hurt, but killed. My government took a rather dim view of these events, and usually the Colony police forces were sent in to restore order.

On one weekend that I remember well, a friend and I were testing out some new mobile equipment we had put together. This friend, Peter, was cruising about twenty miles away in Kikuyu country, close to the Masai reserve south of Nairobi. At about 10 PM he ran into a scuffle going on near a Kikuyu cattle kraal. He got out of his car to see what was going on and was at once ordered by two Masai young men, fully armed with spears and knives, to stay out of the way. He did not argue but got back into the car and called me on the 40-meter channel. I quickly got the picture and guessed that this could easily be the start of one of those periodic mass raids of the Masai on the Kikuyu for cattle and wives. Peter said that he would get out of there and move along the reserve boundary to get information.

I decided that we had better get the government in on this at once, as it could mean a lot of casualties on both sides.



The skating pond, Lewis Glacier — Mount Kenya.



The Lewis Glacier, Mount Kenya — on the Equator.

The Police Commissioner was well known to me, so I called him and eventually dug him out of his club. At that time I was president of the local Radio Society (10 members!), so I offered the Commissioner our assistance; I knew the police had extremely limited communications.

By midnight we had four mobile stations operating and we began to get the whole story. It was indeed a full-scale raid, and the first estimates of several hundred cattle and a score of women taken were recorded from an active front of several miles. By 2 AM several hundred African police and a dozen of their officers were on the scene, and the Masai had melted back into their own reserve with the loot. The police chose not to follow them across the border — the Masai possessed a reputation that was extremely discouraging to all other tribes. There were quite a few wounded and two or three were killed, and a score of Kikuyu families bemoaned the loss of daughters and younger wives, not to mention the loss of

several hundred cows and calves.

On the whole it was a very successful night — for everybody else. The Masai no doubt were celebrating, the police got a very good write-up for prompt and efficient military action, the Radio Society gained enormous prestige and was at once engaged as consultant to advise the Police Force on the immediate acquisition of a new and modern communications system, called radio. Everybody forgot the poor Kikuyu, but they got their revenge eventually; they had to wait for nearly twenty years for the time of independence from the British, but then some old scores were settled.

Medicine and witch doctors

An American missionary group active in Ethiopia was unusual in that nearly all its Western personnel were amateur radio operators who used ham radio as the communications system to tie their widespread operations together. The undeveloped nature of the country and its



Street scene — Zanzibar.

fearsome and mountainous terrain makes severe problems for communications. This group not only used ham radio for field operations, but also made use of DX conditions for constant contact with home bases — we could hear them often on what I believe is still called short skip. This ionospheric phenomenon was sufficiently frequent to allow us to talk regularly with Addis Ababa and other parts of the country.

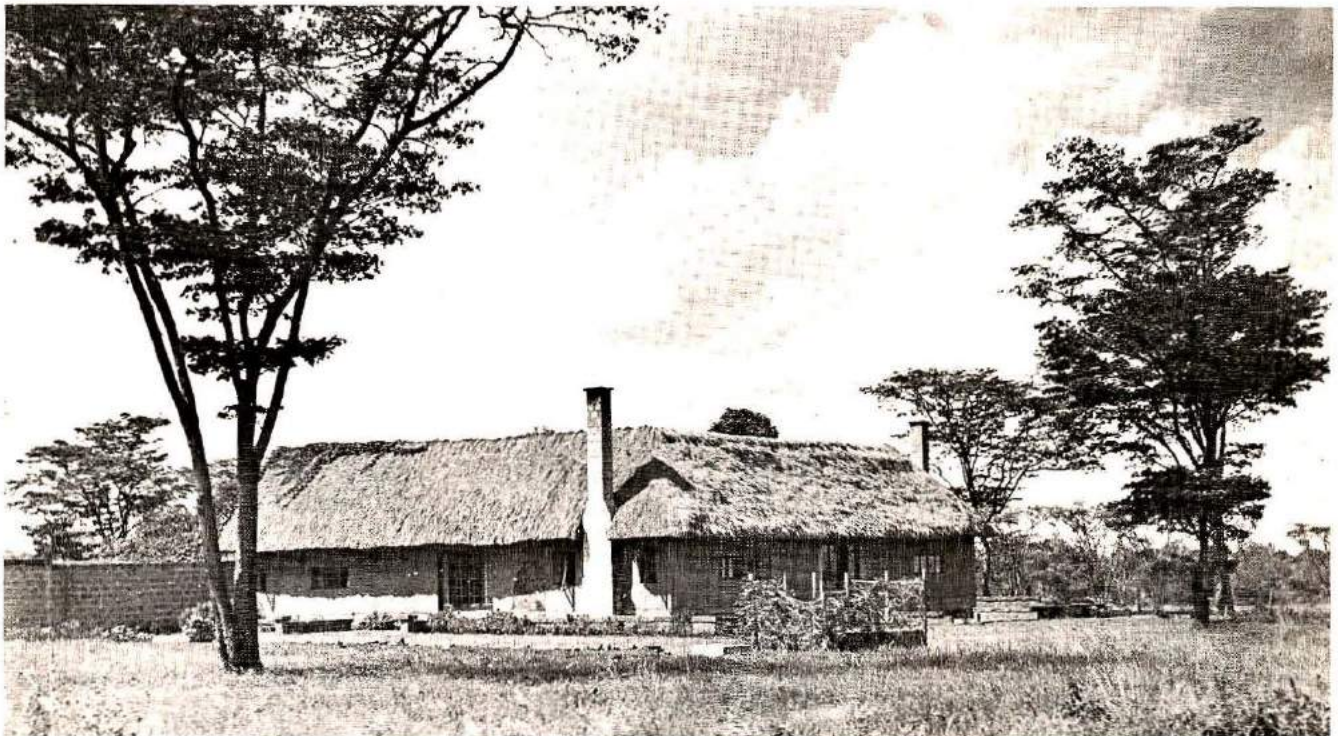

The land was flat and open, providing excellent space to erect antennas.

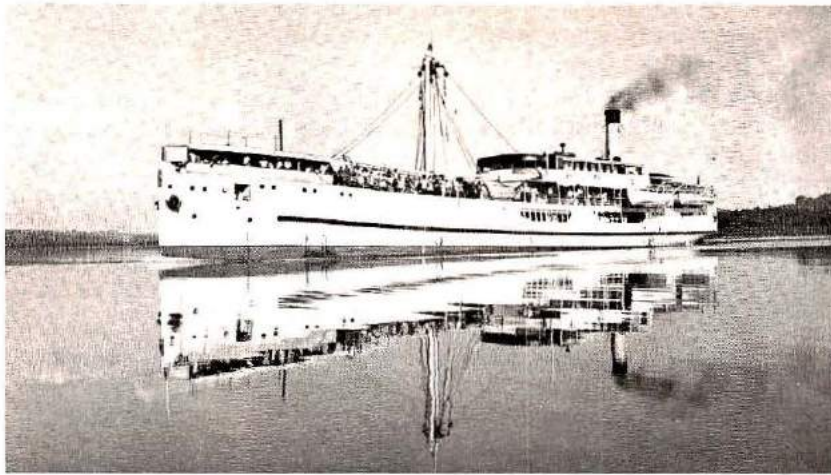

S.S. "Usoga" — Lake Victoria, with VQ4NSH/mobile on board.

The missions often maintained medical facilities on their compounds — no doubt very primitive when compared to the Mayo Clinic — but of great value in a village possessing only the dubious services of what we are pleased to call witch-doctoring.

Incidentally, the term is mutual. I was showing a movie to a group of remote villagers in northern Uganda who certainly had never seen a piece of magic of such stupendous power. I knew the language and so was aware of the remarks around me. The awesome silence as the screen first filled with moving figures was broken by a howl of fear from the children, and frantic sighing and finger biting from the adults. When the children collected their wits — after fearfully stopping in their tracks to see if they were still alive — they crept back wide-eyed and stood petrified on one leg. One of the older ones, of superior courage and high intelligence, bravely approached the screen and carefully moved his head from the front of the screen to the back. He then let out a loud yelping, laughed, and jumped up and down in great excitement, calling out again and again a word that meant approximately "only white witchcraft." After a while most of the other children crowded around the screen

looking behind it with puzzled expressions, but with little fear.

Someone soon discovered that by standing in front of the screen they could blot out the picture with their own shadows, so the last fears disappeared and it was all a huge joke. On the other hand, I was a manipulator of magic — the classic definition of a "witch doctor." The Africans who were aware of my activities with world-wide radio contacts were extraordinarily uninterested. I don't really think they believed me when I attempted to explain what I was doing — they were polite and would appear amazed at my claims, but I noted their incredulity. To them it was another example of Western witchcraft, rather outside their ken.

One late afternoon I happened to be tuning the 10-meter band for possible interesting DX when I heard a rather strained American voice making a traffic call to VQ country. It was an Ethiopian station and, I guessed, one of the mission stations, but I could not imagine why he was calling us so urgently. I answered him and asked what I could do for him. I did not know then that this was to turn into the longest QSO in local history. Ethiopia is a large country, about twice the area of Texas, very rural, and with a

dozen or fewer small towns at long distances from each other. Miserable roads join them haphazardly. It seemed that there was some kind of conference going on in the capital, Addis Ababa, and all the doctors from outlying stations were gathered there.

The medical assistant at this remote hospital had been landed with an emergency. He described, in some gory detail, the condition of the victim of a lion mauling who had been brought in by his friends from twenty miles away. He needed surgery very soon, and could I call Addis Ababa and somehow contact the surgical chief to get instructions about how to proceed? I urgently called CQ Addis and after quite a while raised an old friend of mine at the British Embassy. It took only a relatively short time to find the doctor at the mission headquarters.

We first tried to get the two stations into direct contact, but the skip distance was all wrong for this, and my friend at the Embassy was exclusively a ten-meter man, so we agreed to do a relay job. This was some task, requiring a great deal of patience and repetition. After two hours back and forth between the surgeon's instructions and the application by the operator at the other end, the poor patient was still alive with a chance of survival. We all congratulated each other. At home, in a state of exhaustion, we had a stiff drink and wrestled up the cook to prepare dinner.

A week or so later I again heard the same station calling Kenya at about the same time; it was the doctor who had carried out the remotely controlled surgery. He told me that it had been a successful operation and the patient was recovering. We had a very heart-warming conversation and felt good about our little adventure.

The changing times

My last few years in Africa

were far less comfortable, and we spent a lot of our time trying to deal with the ravages brought on by the terrifying activities of Mau Mau. Our radio activities this time were geared to grimmer ends; to capture and incarcerate terrorists and killers. The Mau Mau objective was to drive out what we conceived to be a benevolent source of social and political benefit to all Africans. Like most revolutions, Mau Mau wanted change on its own short-sighted terms. Africa was a different place after this less-than-successful and abortive revolution, but the changes now came more rapidly and decisively.

I went back to Africa just before the thrust toward self-government reached its culminating peak — the handover of power to the new African government. The country was pregnant with hope and excitement, with some anxiety and apprehension on the part of those who were to relinquish their power and privilege. Africa was at the end of an era, an end that only a few regretted. From now on the Africans would make their own decisions and control, in large measure, their own destiny.

As I left Nairobi for the last time, and the plane was climbing above the high plateau, the flight-deck door was open and I heard the pilot talking to the control tower. I thought back to my times as VQ4NSH with sweet nostalgia, to the great moments and the absorbing interests. My contacts with North America, the warmth of friends I had made there, and my admiration for the "American idea" could be traced in large part to that extraordinary fraternity of ours. I, too, had come to the end of an era and had finally abandoned the Colonial role. I was happily embarked on my way to my own new land of freedom and opportunity, with a most hopeful future.

HRH

CUSHCRAFT IS THE FM ANTENNA COMPANY.

Cushcraft manufactures the world's most complete line of quality antennas for amateur VHF-FM repeater service including high-gain multi-element vertical beams, stacked arrays, 5/8-wavelength mobile whips, half-wavelength Ringo® verticals, and the world-famous Ringo Ranger®, which features stacked vertical half-wavelength elements for 4.5 dBd omnidirectional gain. Whether your favorite repeater is next door or across the state, Cushcraft has a VHF-FM antenna which is exactly engineered to your needs.

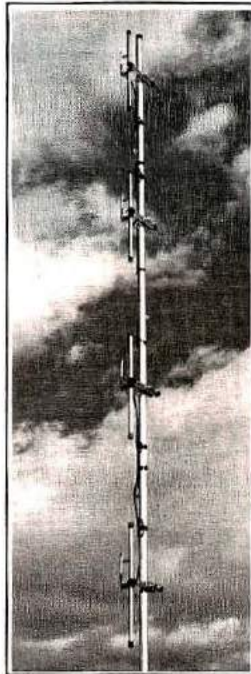

Four Pole

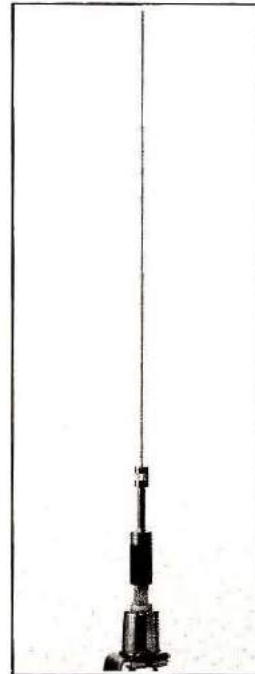

5/8 wave Mobile

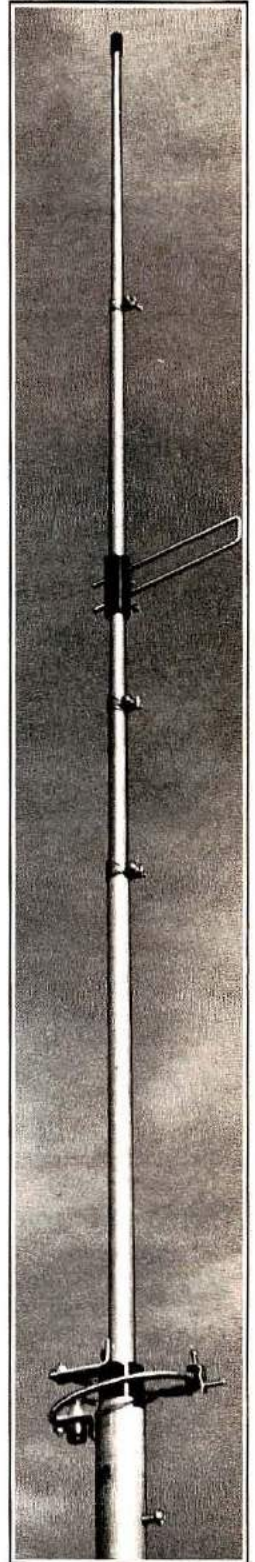

Ringo Ranger®



UPS SHIPPABLE
cushcraft
CORPORATION

In Stock With Dealers World Wide P.O. Box 4680, Manchester, N. H. 03108

ANTENNA TUNING WITH A NOISE BRIDGE

BY JACK ALTHOUSE, K6NY

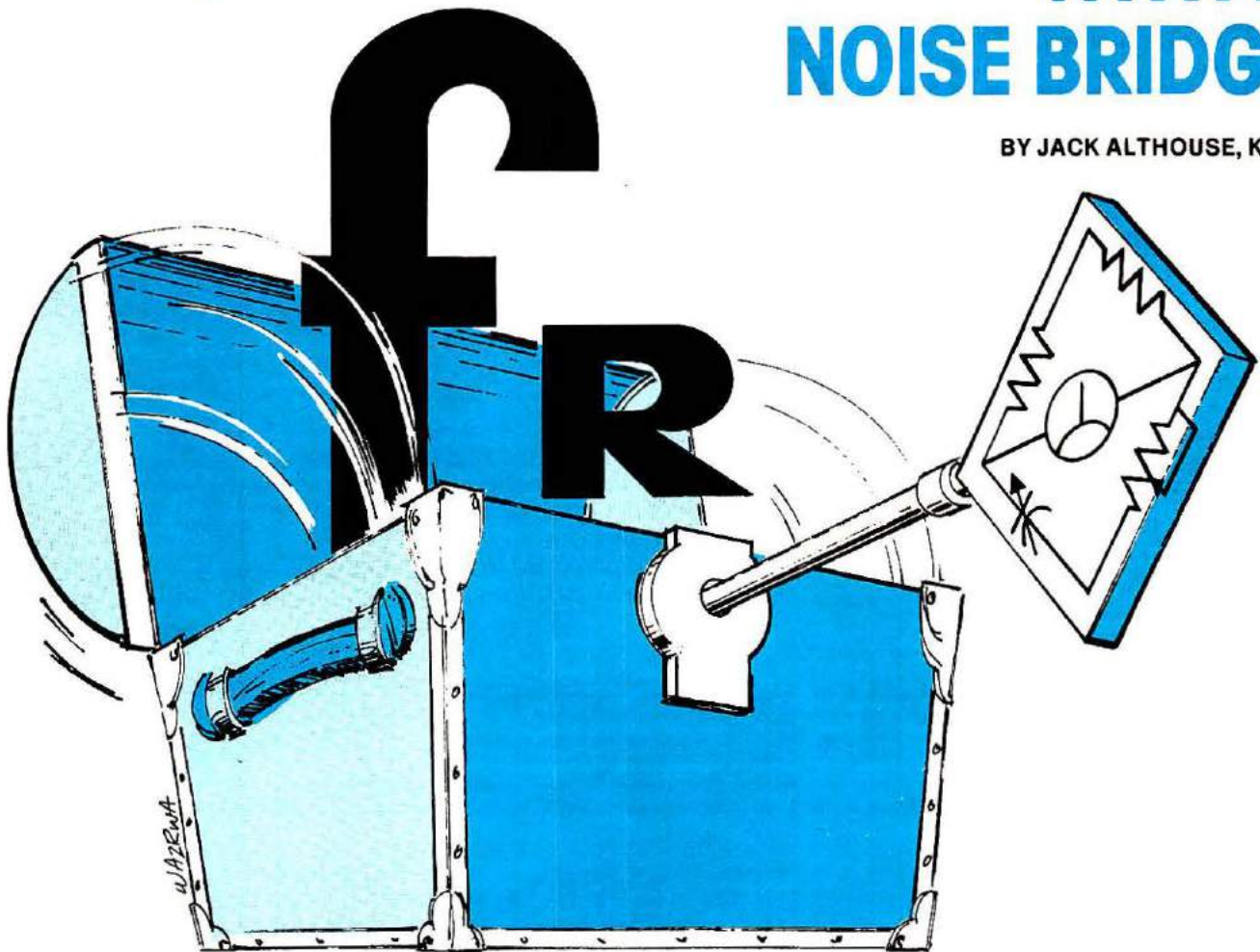

The noise bridge is a measuring instrument used to find the resonant frequency of an antenna, to tell whether to make an antenna longer or shorter to make it resonant, and to measure the antenna's resistance. Also, it will indicate the resistance and reactance of an antenna that is off-resonance, and make other useful measurements around the amateur operating room.

It is not an antenna tuner; it is used with a receiver to make resistance and reactance measurements.

How it works

The RX noise bridge contains a wideband noise generator and an rf impedance bridge.

The "known" leg of the bridge has a calibrated variable resistor and a calibrated variable capacitor controlled by front-panel knobs. The "unknown" leg of the bridge connects to the antenna to be measured. A receiver tuned to the measurement frequency is used as the detector.

When the noise bridge is first turned on, a loud noise from the noise generator will be heard in the receiver. The R and C knobs, controlling the variable resistor and capacitor, are then adjusted for a noise null. The R knob reads the antenna resistance.

The X knob, if it points at zero, says that the antenna is resonant. If it reads on the X_L

side of zero, the antenna is inductive; that is, it is too long to be resonant at the measurement frequency. If it reads on the X_C side, the antenna is capacitive; that is, it is too short to resonate at the measurement frequency.

Tuning a dipole

Here's how to use the RX noise bridge to tune a dipole or inverted vee to resonance. First, connect the "unknown" terminal of the noise bridge to the center of the dipole. Later in this article we'll explain how to make this measurement at the bottom end of the coaxial transmission line, but, for now, connect the noise bridge right up at the center of the antenna.

Next, connect your receiver to the "receiver" terminal of the bridge through any convenient length of coaxial line.

Tune your receiver to the frequency at which you want the antenna to resonate. Turn off the receiver's AGC and place the speaker so you can hear the noise signal, or arrange the set so you can see the S meter. Turn on the noise bridge and adjust the R and X knobs for null. The controls interact and must be adjusted alternately until a deep null is obtained.

If the X reading is on the X_L side, the antenna is too long. If the reading is on the X_C side, the antenna is too short.

Adjust the antenna length and take another measurement. Repeat this until the null is at $X=0$. The antenna is now resonant on the desired frequency. The R knob indicates the feedpoint resistance.

Trap dipoles

The noise bridge will give a null for each band that the trap dipole resonates on. Connect the bridge at the center of your horizontal trap dipole or at the base of your vertical trap antenna.

Start with the highest frequency band and measure the resistance and reactance as described above. Adjust the center (or lower) section, if necessary, for a null. Then repeat the procedure on the next lower frequency band. Work your way down in frequency until you have adjusted the lowest-frequency section.

Beams

Connect the noise bridge to the driven element. Tune your

receiver to the operating frequency and read the resistance and reactance. Adjust the driven element to resonance if needed.

Ladder too short?

Sometimes it is not possible to make the measurements at the antenna. Instead, the noise bridge can be connected at the bottom of the feedline. But beware! The readings you get at the bottom of the feedline will probably be completely different from those you got up at the antenna.

Why? Because the resistance and reactance seen at the bottom of the feedline change with the length of the line — the noise bridge measures what it sees. However, there is a magic feedline length — the half-wave line. If the feedline has low loss and is an electrical half-wave, or a multiple of a half-wave, readings taken at the end of the line are exactly the same as those taken at the antenna. Of course, there is just one frequency where the line is a half-wavelength, and all measurements must be made at this frequency.

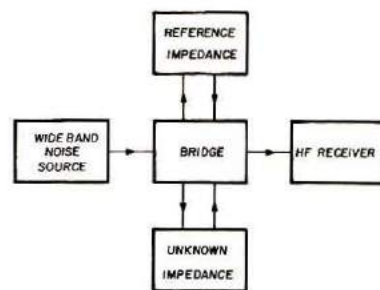

Fig. 1. The noise bridge system includes five major elements, three of which are internal to the instrument. The heart of the instrument is the bridge section itself. This is excited by a broad-spectrum noise source. The unknown impedance and a reference impedance form separate legs of the bridge section. The reference impedance is varied until it equals the unknown impedance. When this occurs, the bridge is nulled and the output of the high-frequency receiver goes to a minimum.

The length of a half-wave transmission line is:

$$L \text{ (meters)} = \frac{150}{F} V$$

$$L \text{ (feet)} = \frac{492}{F} V$$

where F = frequency in MHz, and V = velocity factor of the line. V is about 0.66 for coaxial cables, 0.8 for foam dielectric

The noise bridge is a miniature test system in ready-to-use form. Its size can be estimated by comparison with the 9-volt transistor-radio battery clipped to the end of the box. For more information, write to Palomar Engineers, P.O. Box 455, Escondido, California 92025.



This article reprinted with permission from the May, 1978, issue of *World-radio*, which is published by World-radio Associates, Sacramento, California.

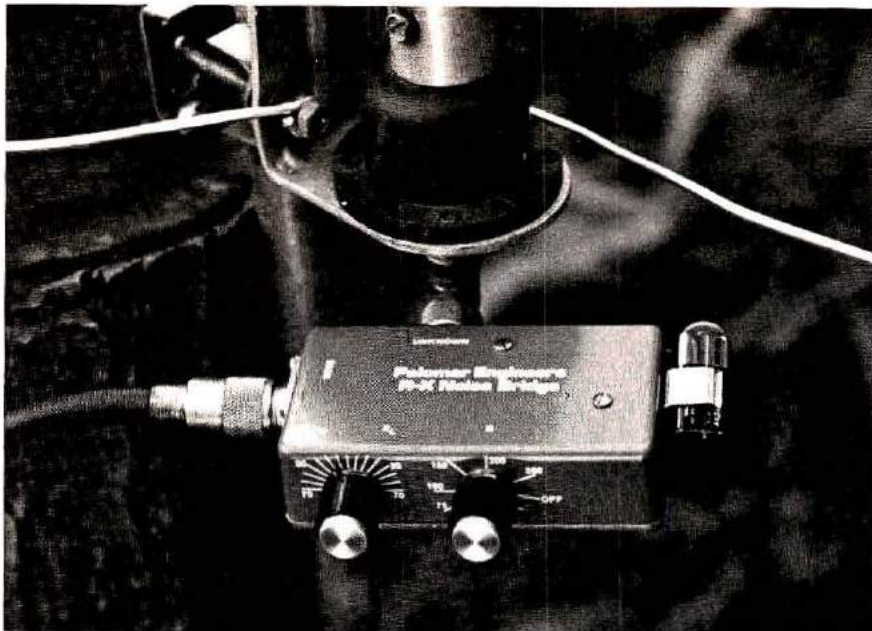

The noise bridge is easiest to use when connected to an antenna right at the feed point. Here it is at the base of a multiband vertical antenna. The normal feedline goes to the receiver, either in the shack or arranged so you can hear the audio output. You can learn much about antenna adjustments and ground systems in a short time with this inexpensive instrument.

coaxial cables, 0.82 for twin-lead.

More than likely, the distance between your antenna and your transmitter is not a half-wavelength or anything close to it. What then?

If you know the electrical length of your line, you can convert the readings taken at the end of the line to those you would read if you were at the antenna. This is done with the Smith chart. This is not something you can master in an evening, but it's not all that difficult either. The procedure is described in the March, 1978, issue of *ham radio* magazine.

Transmission lines

You can cut the line to correct length using the formula, but, because of different manufacturing methods and tolerances, the line you have may not have the exact velocity factor listed above. If so, the formula will give you the wrong length, so you should check it by using the noise bridge.

The magic property of a half-wave line is that what you connect to one end of the line

is what you read at the other end. If you put a short circuit at one end, then you will read a short circuit at the other end. That is, $R = 0$ and $X = 0$.

Before making the measurement you should calibrate the noise bridge by shorting the "unknown" terminal and adjusting the R and X knobs for null. The null will be at $R = 0$ and $X = 0$, but, using this procedure, you will be able to set the knobs more accurately than by reading the printed scales.

Now connect your half-wave line to the "unknown" terminal. Short the far end. Do not adjust the R or X controls. Find the half-wave frequency by tuning your receiver to the noise null. Prune the line slightly, retune the receiver to null, and repeat the procedure until the desired frequency is reached.

Helpful hint: it is easier to cut the length of a line than it is to add to it. Start with your line a bit longer than the formula says. As you trim the line, its half-wavelength frequency will *go higher*.

Save that final

If you use an antenna tuner, you can use the noise bridge to set its controls without turning on your transmitter. Just connect the noise bridge to the transmitter side of the tuner. Set the noise bridge controls to $X = 0$ and $R = 50$ ohms. Adjust the antenna tuner for a noise null. Now the tuner input is 50 ohms with no reactance, just what your transmitter wants to see.

Caution: Remove the noise bridge from the line before transmitting.

If you have a dummy load you can tune your transmitter into it. Then connect the transmitter to the tuner and you are all tuned up and ready to transmit without ever having been on the air.

How nice it would be if everyone tuned up this way! We'd have no more of those interminable carriers that go on and on while someone is trying to find that magic combination of knob settings that loads his transmitter properly. Tubes last a lot longer, too; more damage is done to finals in tune-up than in many hours of operating.

Test a balun

How do you tell if a balun is good? Not with an ohmmeter, because most baluns have all input and output terminals connected together for dc. You read a direct short whether the balun is good or not.

Instead, connect your noise bridge to the coax fitting of the balun. Then, if it is a 1:1 balun, put a 50-ohm resistor across the output terminals. A quarter- or half-watt, carbon-composition resistor will do. Now turn on the noise bridge and adjust it for a null. You should read $X = 0$ and $R = 50$ ohms.

Tuned circuits

A dipole antenna looks like a series resonant circuit and the noise bridge is designed to find the resonant frequency. It's easy to see that you could

connect any other series resonant circuit to the noise bridge and find its resonant frequency.

But there is one difference: the antenna has a radiation resistance of 50 ohms or so; tuned circuits used in transmitters and receivers have very little resistance. So, to check a series tuned circuit, set the R knob and the X knob at zero. Tune your receiver to the frequency you want and adjust your tuned circuit for a noise null.

You can check parallel circuits the same way, but they have to be connected to the noise bridge by a one- or two-turn link threaded through the coil.

The noise bridge works better than a dip meter for this purpose because the frequency of measurement is determined by your receiver, which is more accurately calibrated than a dip meter and is more stable.

Noise bridge or swr meter?

If you've been using your swr (standing-wave ratio) meter to adjust antennas, you've been working with one hand tied behind your back. The RX noise bridge is a lot more useful because it tells you which way to go; the swr meter does not.

Suppose, for example, that you have a 25-ohm antenna and 50-ohm coax; $swr = 2$. Suppose further that you have a 100-ohm antenna; again the $swr = 2$. In other words, the swr meter can't tell the difference between a 25-ohm and a 100-ohm antenna, but the noise bridge can. If the antenna is 25 ohms it reads 25 ohms; if 100 ohms, it reads 100 ohms.

Also, the swr meter can't tell if you are above or below resonance. The noise bridge can. It reads X_L above and X_C below.

For routine operating the swr meter is great. But for antenna construction and test, and for many other jobs around the station, the noise bridge can't be beat. Try one, you'll be pleasantly surprised. **HRH**

R-X Noise Bridge

All Palomar Engineers products are made in U.S.A. Since 1965, manufacturers of Amateur Radio equipment only.



- Learn the truth about your antenna.
- Find its resonant frequency.
- Adjust it to your operating frequency quickly and easily.

If there is one place in your station where you cannot risk uncertain results it is in your antenna.

The Palomar Engineers R-X Noise Bridge tells you if your antenna is resonant or not and, if it is not, whether it is too long or too short. All this in one measurement reading. And it works just as well with ham-band-only receivers as with general coverage equipment because it gives perfect null readings even when the antenna is not resonant. It gives resistance and reactance readings on dipoles, inverted Vees, quads, beams multiband trap dipoles and verticals. No station is complete without this up-to-date instrument.

Why work in the dark? Your SWR meter or your resistance noise bridge tells you only half the story. Get the instrument that really works, the Palomar Engineers R-X Noise Bridge. Use it to check your antennas from 1 to 100 MHz. And use it in your shack to adjust resonant frequencies of both series and parallel tuned circuits. Works better than a dip meter and costs a lot less. Send for our free brochure.

The price is \$49.95 in the U.S. and Canada. Add \$2.00 shipping/handling. California residents add sales tax.

Fully guaranteed by the originator of the R-X Noise Bridge. ORDER YOURS NOW!

Palomar Engineers

Box 455, Escondido, CA. 92025 • Phone: [714] 747-3343



PRESS MEETS HAM



BY BOB KALAHAR,
WB8QWP



Quiet on the set. Lights. Camera. Sound. Action!

"Hello? Hobby editor? This is Leonard Ohm and I've got a complaint about your series of articles on different hobbies."

"What's your complaint, Mr. Ohm?"

"You haven't had anything about amateur radio."

"You must have missed our article of last Thursday, Mr. Ohm. Two-and-a-half columns about Citizens Band. . ."

"That's not amateur radio, Miss. . . What's your name?"

"Ms. Cronkite — but no

relation. Ha ha."

"Well, Ms. Cronkite, have you ever heard of ham radio?"

"Certainly. It's another name for CB, isn't it?"

"Surely you jest, Ms. Cronkite. It's another name for amateur radio, which has been with us more than fifty years. It's a worldwide hobby. By comparison, CB is a rookie. . ."

"Really. Well, tell me about it, Mr. Ohm."

"Hams have to pass a government exam on Morse Code, radio theory, operating procedures, and FCC regulations to get a ticket,

which is a license. We communicate with other hams by CW or ssb. These contacts are called QSOs . . ."

(Shuffling of papers)

"Hold it a second, Mr. Ohm. What channels are you fellows on?"

"We're not all fellows, Ms. Cronkite. Some of us are YLs, and we're not on channels. That's CB again. Hams operate on bands, such as 80 meters, 20 meters, 6 meters, and so forth . . ."

"Oh, you people are already into metric. Good. At least that's something to peg the story on. Tell me about your apparatus, or whatever you call it."

"Sure. All hams have a receiver and a transmitter — often a transceiver — a power supply, and an antenna, of which there are randoms, dipoles, verticals, inverted Vees, and beams to name a few. We also have mikes. And we have keys, which can be manual, semi-automatic or electronic. These are called hand keys, bugs, and keyers. Bugs make dashes manually and dots automatically. Keyers make both dots and dashes automatically. Hand keys . . ."

"Where do you people keep all this stuff?"

"We call it gear, Ms. Cronkite, we keep it in our shacks. . ."

"Which are in back yards, I presume."

"Not necessarily. Shacks can be in garages, basements, attics, rec rooms, dens . . . My shack is in the bedroom."

(Pause.)

"The bedroom? Are you putting me on, Sir?"

"No way. But I'm planning to move it to the dining room. We don't have many dinner parties these days, and my XYL . . ."

"Fantastic! Now what about jargon, Mr. Ohm? CB has a lot of colorful jargon that helped hype up our article . . ."

"Sure. Amateurs go eyeball-to-

eyeball at hamfests where we buy, sell, or swap rigs and other gear — new, used, and homebrew. When we work DX we like to trade QSL cards. On the air we say such things as 73, 88, FB, QRM, CUL, OM, landline, and barefoot. And for laughter we send HI.”

“Why?”



“Bugs make dashes manually . . .”

“Did you ever try to laugh in CW, Ms. Cronkite?”

“Right. Well now, let’s see if I’ve got it all straight in my notes here . . .”

“Go.”

“Amateurs are ticketed by the FCC to communicate by CWSSB on metric bands with YLs using rigs, V-poles, and bugs. They build shacks at random from basement to attic, where they keep gear and homebrew. Or was it homebrew at hamfests? Or barefoot in the bedroom? It’s quite confusing. Anyway, they call out signals like 73-88-DX, which means QSL. Or was it CUL? And for laughs they high. Is that about it, Mr. Ohm?”

“Maybe, Ms. Cronkite, we’d better forget the whole thing.”

“Right. I doubt that our readers could relate to a far-out hobby like that anyway, Mr. Home.”

“The name is Ohm — but no relation, hi hi. Diddle de dah de dah, Ms. Cronkite.”

“Diddle de what?”

“Dit dit.”

HRH

CUSHCRAFT IS THE HF MULTIBAND ANTENNA COMPANY.

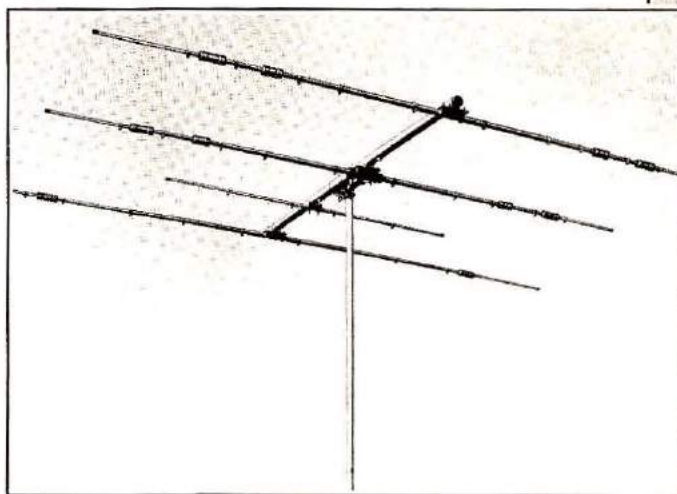

ATB-34, Three Band

Cushcraft manufactures a full range of high-frequency antennas which are performance engineered for the most discriminating amateur. For the amateur who demands top performance in a multiband Yagi beam there’s the incomparable ATB-34 three-band beam for broadband, high-gain coverage on 10, 15 and 20 meters.

And for the Amateur with limited antenna space and budget who wants reliable, multiband radio communications there are three Cushcraft multiband verticals to choose from: the three-band ATV-3 for 10, 15 and 20; the four-band ATV-4 for 10, 15, 20 and 40 meters; and the ATV-5 for low VSWR five-band performance from 80 through 10 meters.

Cushcraft high-frequency antennas are quality engineered for top performance; they are often imitated, but never duplicated.



ATV-4, Four Band



In Stock With Dealers World Wide P.O. Box 4680, Manchester, N. H. 03108

Station design



Part 3

BY KARL T. THURBER, JR., W8FX/4

**Tips on making your station safe for you
and others and some advice on how to
cope with emergencies**

Electricity must be treated with respect. Nothing can be more devastating than an accident caused by careless construction when working with electrical circuits. When you plan your amateur station, a few moments spent in thinking about how to make your station safe for yourself and others will pay off in peace of mind.

In this article I've given some tips on electrical safety, gained from experience, that will help you avoid possible catastrophe when you put your amateur station together.

The first thing to consider, when planning your station, is physical access, particularly if children are in the house who might turn on equipment that may cause injury. A locked room is probably the best way to ensure that access is limited. The next best method is to install a key-operated switch in the main ac line to prevent accidental activation of the primary electrical circuit. Note that the Federal Communications Commission requires that the station must be under *your control* at all times!

Antenna safety

Safety is closely related to antenna grounding and lightning protection. The antenna system should be protected in some manner, such as by installing a coax lightning arrestor and a heavy ground lead. You can do this with beam antennas that use gamma or T matches — this arrangement keeps the antenna elements at ground potential. The key lies in providing a *direct path* from antenna to ground, so that any electrical charges will be discharged harmlessly to the earth rather than through the house and the ham gear.

If you use a single-wire or twin-lead transmission line, make provisions to disconnect and ground the line where it enters the house. You can do this by installing a heavy-duty knife switch on the window sill.

Use it to disconnect the antenna from your equipment and to ground when you're not transmitting.

Inside the shack there are several things you can and should do to minimize the effects of a nearby or direct lightning strike. All metal cabinets should be bonded together by a common ground bus wire, which should be run to a cold-water-pipe ground. All equipment should use three-wire grounding type ac plugs. Be sure that "third wire" is actually at *ground potential*. The antenna should be disconnected from the equipment and grounded when not in use.

And — not to be overlooked — if you have a master switch for the station, it should be pulled during electrical storms to prevent lightning strikes on the ac mains from inducing high surge currents into house wiring and thus into your equipment. This is extremely important. If you do this, you'll reduce the risk of damage to power supplies, relays, and anything else tied into the ac mains. If you don't have a master switch, disable the circuit breakers, or better yet, pull the ac line cords to your equipment.

Inside the shack the equipment should be well grounded. You can get an



A coaxial lightning arrester such as the Cushcraft "Blitz Bug" can be installed outdoors to help protect the transmission line and station equipment. In addition to protection from direct lightning hits, it also helps to drain off excess accumulated static charges on the line during periods of intense storm activity. To be effective, it must be used in conjunction with a good exterior ground system.

effective ground by running a heavy copper or aluminum wire or copper braiding shield to a nearby cold water pipe. Note that hot water pipes often *don't* have a direct ground connection. Connect the wire or braid to the pipe with an automobile hose clamp or a TV-type ground clamp. This wire (or ground buswire) can also be run outdoors to an additional ground rod or rods for added protection.* Bond all the ground terminals of your station equipment together using copper braid, and connect the common wire to the ground buswire.

The house current

Many hams who show respect for high dc voltages underestimate the lethal potential of ordinary 115-volt ac house current. Bear in mind that simply turning power off *doesn't* assure that a circuit is dead.

Occasionally, a fault will occur that raises the potential of a cabinet above ground. You can receive a serious shock with the power *off* if the equipment is still plugged in. How? If one of the rf bypass capacitors across the ac line (inside the equipment) shorts out or becomes leaky, an ac potential may appear on the cabinet if not properly grounded and fused. If you touch some grounded object such as the transceiver, microphone, or key and the faulty unit at the same time, the current will flow *through you*.

Don't ever attempt to add to, or work on, wiring in outlet boxes, sockets, or extension cords without absolutely ensuring that *both sides of the circuit are dead*. This is best done with an ac voltmeter. And, don't work on ac lines or any electronic gear with wet hands, as moisture dramatically lowers skin resistance and allows increased current to flow

*You can also connect ground radial wires for a vertical antenna to this ground wire. The more radial wires, the better — Editor.



Don't

should you receive an electrical shock.

Working on equipment

Many cautious old timers quote an additional basic safety rule: "Keep one hand in your pocket while working on equipment!" There is logic to this rule: your free hand won't accidentally touch a hot circuit, and should it, the electrical path won't be through the chest cavity, where the most damage could occur.

While most solid-state equipment operates on low internal dc voltages, you can still get unpleasant shocks from such equipment. Also, most high-power gear uses tubes in the output stages, which means that a power supply in the equipment is capable of developing 500 to 1000 volts or more. Be especially careful in opening high-voltage compartments. Be sure to *short to ground* all wiring carrying high dc voltages before working on the equipment. Be absolutely sure that there is no hv potential at any point with which you might come in contact. The reason for taking this precaution, of course, is that the power-supply filter capacitors store electricity, and if the bleeder resistors in the power supply should open up, the full potential still exists across the hv circuit, even with power removed. Be sure, too, that any test equipment is also properly grounded, particularly if you



Don't

must work with power on the equipment under test.

Basic safety rules

If you're careful, there's little risk that you will ever receive an incapacitating or fatal electrical shock. This means being cautious, both when working on equipment and when working on antennas (taking care not to let your new skyhook come in contact with overhead power lines). It's also a good idea to have someone else with you when working on equipment who can render assistance.

Both you and your family should know basic emergency treatment for electrical shock. Your local public-service department, Red Cross, or YMCA should be able to steer you to lifesaving courses that may very well come in handy. Here are a few basic safety rules for emergency treatment:

1. Turn off the power.
2. Pull the victim clear of the equipment by his clothes.
3. Immediately apply artificial respiration or other appropriate treatment.
4. Obtain assistance, preferably by shouting.
5. Don't stop revival attempts until a physician arrives.

Electrical fires

Electrical shock presents one hazard in the ham shack, fire is another. Be aware of the fire potential in the shack in view of all the electronic equipment, electrical wiring, lightning hazards, and multiple outlets. Certainly, the fire danger is there, and living in a so-called fireproof dwelling is

no guarantee of safety. Pay careful attention to all entrances and exits to the shack and your home. Can everyone, including the operator, get out if the need arises? Do you have easy access to master power circuit breakers to remove house power if a fire starts? Do you and your family have the fire department's phone number handy? Does your spouse know what to do in such emergencies?

A very good investment is in a chemical fire extinguisher. It can be mounted just outside the entrance to the ham shack. Be sure that other family members know how to use it when you're not present, and be sure to periodically check it. When buying the extinguisher, ensure it's the type that can be used on electrical fires.

Smoke detectors

In home fires, most victims die from monoxide and smoke inhalation. *Smoke detectors* help remedy this situation by acting as early-warning devices.



GE's Home Sentry smoke alarm sounds the alarm before appreciable smoke is present — at the earliest stages of a home fire — while there's still time to escape. Test button allows testing of the entire system (not just the alarm). This reliable alarm system is available in ac wired-in, corded, and dc battery-operated models (photo courtesy General Electric).

They can provide the few minutes warning you need to call for help. Smoke detectors detect noxious gases as well as smoke. They usually contain their own backup battery power supply and a piercing audio signal loud enough to wake even the heaviest sleepers. Most of these units have a failsafe arrangement that signals when the battery is weak and needs replacement.

Over 100 companies have entered the smoke-detector market, introducing an atmosphere of keen competition and equally competitive pricing. Some units with good features sell for as little as \$15 or so — but look for an UL label, which shows that rigid specifications and reliability requirements have been met.*

In this series of articles on amateur station design we've considered what's involved in choosing a location, arranging your equipment for maximum utility and convenience, making electrical and rf connections, and making the station safe for yourself and others.

If you'd like more information on setting up your station, consider the publication *So You Want to Be a Ham*, by Robert Hertzberg, K4JBI.† It has information on setting up an amateur station as well as advice on operating.

One final point: don't make your ham shack a special domain for yourself alone. Other family members and visitors can enjoy the shack too if it's neat and pleasant. And, who knows, perhaps they might get the bug. However you do it, once you have the shack fixed up *your way*, you'll be ready to enjoy ham radio to its fullest extent.

HRH

*For further treatment of the fire and safety hazards in the home and ham shack, see "Fire Prevention In the Hamshack," by James R. Fisk, W1HR, in the April, 1978 issue of *Ham Radio Horizons*.

†Published by Howard W. Sams and Co. Available from Ham Radio's Communications Bookstore, order 21343; \$5.95 plus 35 cents shipping and handling.

GIANT KILLER!

ATLAS 210x/215x

5 BAND - 200 WATT - ALL SOLID STATE HF SSB CW TRANSCEIVER

Don't let its small size, and light weight fool you . . . the Atlas 210x/215x is a top notch performer, with all the power and performance that you find in rigs twice as big, and costing twice as much. And none of the others have as many superior features as our little Giant Killer, regardless of their size.

- ALL SOLID STATE DESIGN.
- 200 WATTS PEP.
- NO TRANSMITTER TUNING.
- 5 BAND COVERAGE ,
(210x covers 10-80 meters,
215x covers 15-160
meters).

- PLUG-IN CIRCUIT BOARDS .
- SUPERIOR SELECTIVITY, with exclusive 8 pole crystal ladder filter.
- EXCEPTIONAL IMMUNITY TO STRONG SIGNAL OVERLOAD AND CROSS MODULATION.
- SLIPS IN AND OUT OF SPECIAL MOBILE MOUNTING BRACKET OR AC CONSOLE IN SECONDS, with connections for DC power input, antenna jack, and mic jack made automatically.

For complete details on the Giant Killer see your Atlas dealer or drop us a card and we'll mail you a brochure with dealer list.



 **ATLAS
RADIO INC.**

417 Via Del Monte Oceanside, CA 92054
Phone (714) 433-1983

Special Customer Service Direct Line
(714) 433-9591

MADE IN U.S.A.

This one's for you.

Because you asked for it . . . we built it. The all-new JR. MONITOR™ Antenna Tuner.

Call it what you will — antenna tuner, match-box, or matching network, the JR. MONITOR™ has it all wrapped up in one neat 5¼" W × 2¾" H × 6" D all metal cabinet.

Here are the features you said you wanted:

Continuous tuning from 1.8-30 MHz. 300 watt power capability. Forward reading relative output power meter — simply tune JR. MONITOR™ controls for maximum RF output on the meter. Built-in balun. Mobile mounting bracket. Ceramic rotary 12-position switch. Capacitor spacing 1000 volts. Tapped coil inductor. Antenna inputs: coax unbalanced SO 239, random wire, balanced feed line 75-660 ohm. Weight: 2½ pounds.

With so many special features — think of the unlimited possibilities you'll have for experimenting with dozens of antennas! For instance, the DenTron All Band Doublet fed with balanced feed line hooked to the JR. MONITOR™ covers 1.8-30 MHz in one antenna . . . or try this mobile suggestion: 108" mobile whip fed with coax to the JR. MONITOR™ located under the dash will give you 10-40 meter mobile coverage and no coils to change!

It's easy to understand the excitement the JR. MONITOR™ has created. Wherever you are — home, boat, car, plane, or campsite you'll always be in contact. It's a fun little tuner that easily fits in a briefcase or coat pocket — but why would anyone want to smuggle it into their radio room?

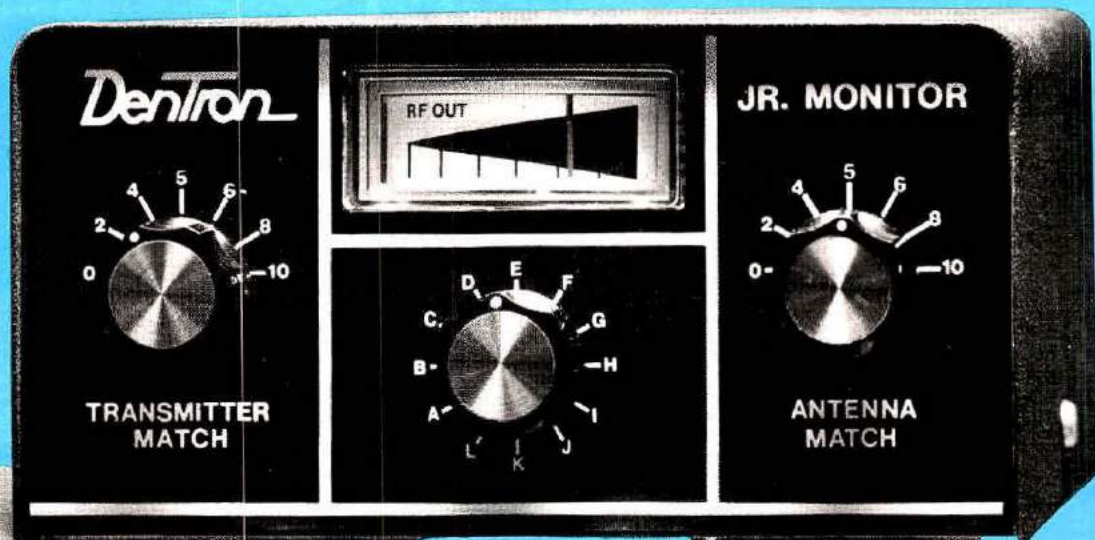

JR. MONITOR™ \$79.50
ALL BAND DOUBLET \$24.50

DenTron

Radio Co., Inc.

2100 Enterprise Pkwy.,
Twinsburg, Ohio 44087

(216) 425-3173

Look closely at the new MT-3000A. You've never seen anything like it.

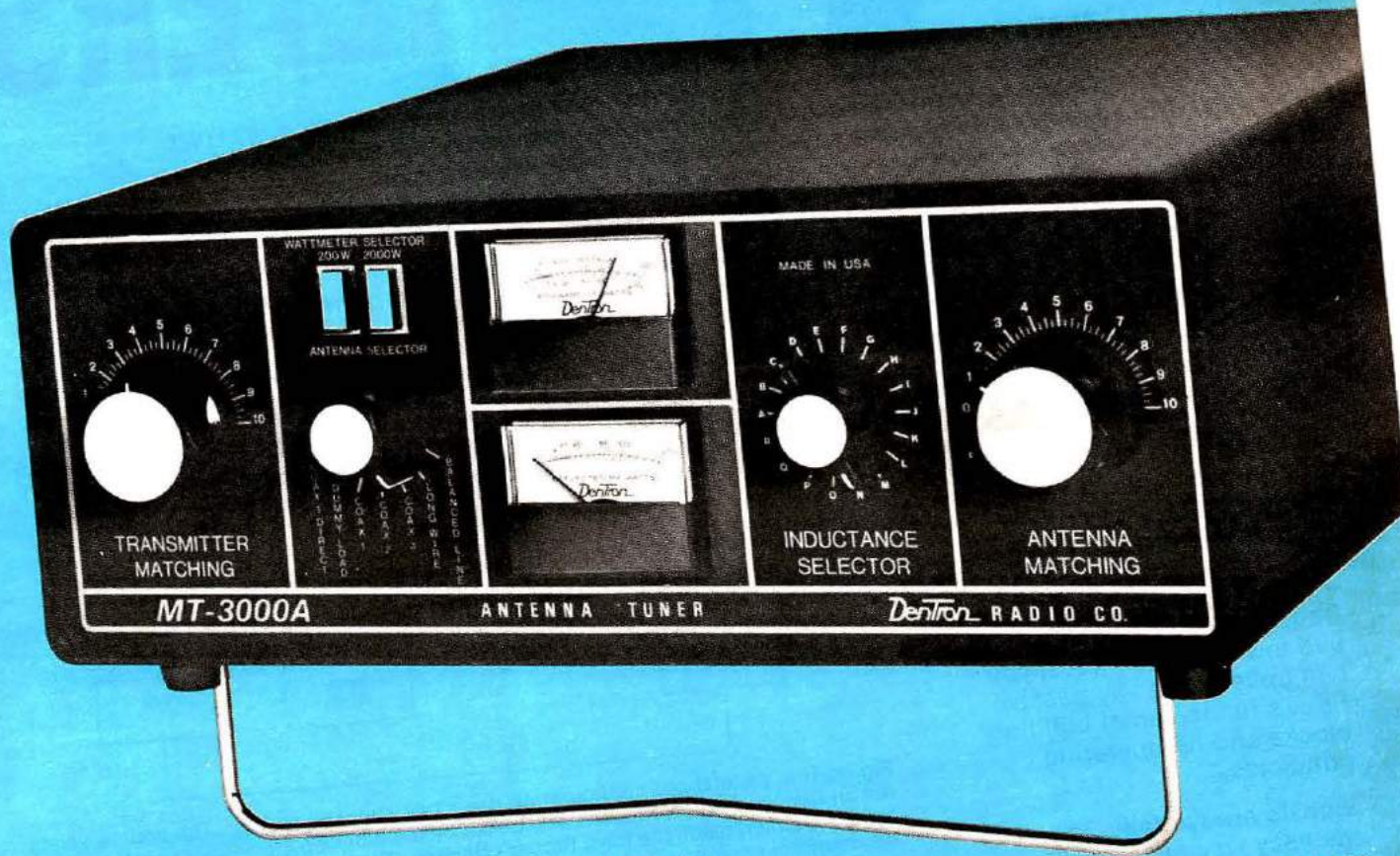

Times have changed since DenTron introduced its first tuner. With rapid growth in condominiums and housing developments, we have new problems that require new solutions.

DenTron decided to rethink the tuner and what its total capabilities should be.

The MT-3000A is a capsulized solution to many problems. It incorporates 4 unique features to give you the most versatile antenna tuner ever built.

First, as a rugged antenna tuner the MT-3000A easily handles a full 3KW pep. It is continuous tuning 1.8-30mc. It matches everything between 160 and 10 meters.

Second, the MT-3000A has built-in dual watt meters.

Third, it has a built-in 50 ohm dummy load for proper exciter adjustment.

Fourth, the antenna selector switch; (a) enables you to by-pass the tuner direct; (b) select the dummy load or other antenna systems, including random wire or balanced feed.

The compact size alone of the MT-3000A (5½" x 14" x 14") makes it revolutionary. Combine that with its four built-in accessories and we're sure you'll agree that the MT-3000A is one of the most innovative and exciting instruments offered for amateur use.

At \$349.50 the MT-3000A is not inexpensive. But it is less than you'd expect to pay for each of these accessories separately.

As unique as this tuner is, there are many things it shares with all DenTron products. It is built with the same meticulous attention to detail and American craftsmanship that is synonymous with DenTron.

After seeing the outstanding MT-3000A, wouldn't you rather have your problems solved by DenTron?

DenTron
Radio Co., Inc.

2100 Enterprise Parkway
Twinsburg, Ohio 44087
(216) 425-3173

RF

PASSIVE FILTERS

BY PAUL G. SCHREIER, WA1TWT

If you know how filter components operate and can recognize several basic configurations, filter classification becomes simple

Filters may look complicated when you see them hidden in a maze of components on a schematic, but they're as simple as the few elements that they include. If you realize that capacitors do nothing more than block dc and pass high frequencies, and that inductors merely block high frequencies while passing dc and low ac frequencies, you can understand any passive filter's fundamental building blocks and its operating principles.*

Signals always take the easy way out

Suppose you're working with a signal generator that delivers all frequencies but you want only a certain frequency group to reach the load (Fig. 1). You can do this by making a low-resistance path for the unwanted frequencies to bypass the load — remember, any signal takes the path of least resistance.

First, use a capacitor as the

bypass element (Fig. 2A). Because capacitors have a low impedance for high frequencies, those signals return to the

called a shunt-capacitor filter because the capacitor "shunts" (or shorts) high frequencies around the load.

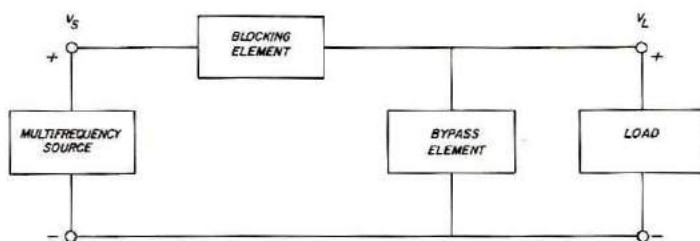

Fig. 1. This generalized configuration describes almost any filter. The source sends out all frequencies; only those not blocked by the blocking element or shorted by the bypass element reach the load. Proper selection of these elements determines the filter characteristics.

signal source without going through the load; the load sees only low-frequency signals. This simple lowpass filter is

There's another easy way to help keep high frequencies away from the load. Instead of making it easy for them to

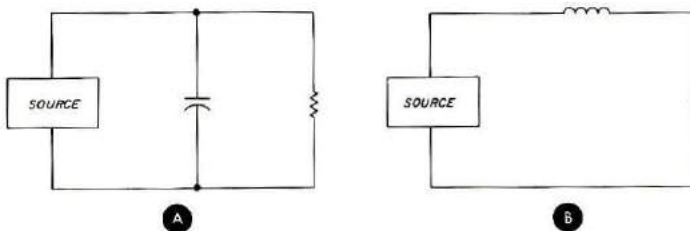

Fig. 2. The simple lowpass filter. The circuit in A uses a single capacitor to shunt high frequency signals around the load; the inductor in B blocks low frequencies from getting to the load.

*See "Understanding Resistors, Capacitors and Inductors," *Ham Radio Horizons*, December, 1977, page 46.

avoid the load, make it tough for them to get there. Inductors, you remember, block high frequencies; a configuration that puts one in series with the load also acts as a lowpass filter (Fig. 2B).

Note in both cases that neither filter works perfectly; some unwanted power does reach the load, but it has been greatly reduced.

If you want better filtering, it makes sense to combine these components. Fig. 3 shows some popular configurations. First, you can hook them in the obvious LC-filter configuration

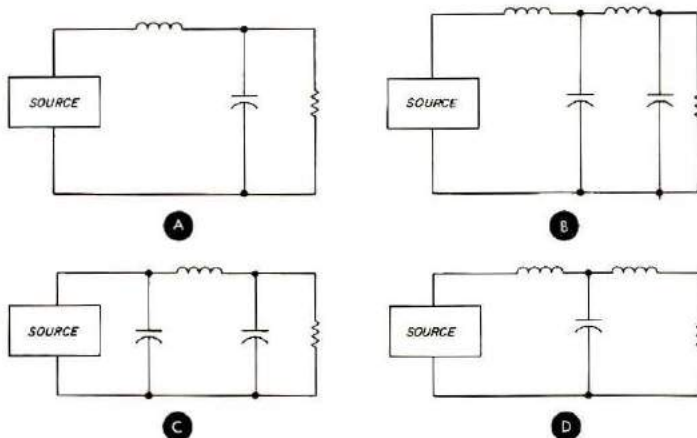

Fig. 3. Combine the elements in Fig. 2 to produce a more efficient filter. Part A shows an LC filter while B shows a two-section LC; C illustrates a π -section configuration while D is a T-section filter.

of Fig. 3A; a second section (Fig. 3B) makes the filter even more efficient. By taking a standard LC combination and adding an input capacitor you create the commonly seen π -section filter (Fig. 3C); you can easily remember its name by its shape — it resembles the Greek symbol whose name it carries. Similarly, you can form a T-section filter (Fig. 3D) by adding another inductor.

Aren't all these designs redundant?

You're probably wondering if there's much difference in all these configurations. The filter's efficiency obviously depends on component values and the number of components; but there's something else, too. Some filter types

operate better than others under various load conditions. For example, a shunt-capacitor filter (and, to some extent, other capacitor-input configurations) passes more high frequencies when load current increases, but adding an inductor helps negate this effect. Input-capacitor sections also let you put a higher voltage on the load. (For a detailed discussion of such effects, see Reference 1.)

Most ham junkbox circuits don't have physical size as a design constraint and you can use inductors liberally for

good filtering. But what can a semiconductor manufacturer do if he wants to put a lowpass filter on an IC chip? — it's tough to use inductors in that situation.

Another design, the RC filter (Fig. 4), solves this problem because it's easy to implement both capacitors and resistors on integrated circuit chips. This method, however, has one drawback: the series resistor in the filter section eats up part of the source's energy; thus, less gets delivered to the load. Circuits that have *small* steady-current loads can live with that restriction, though. And, as before, you can add more sections to improve the filtering (or removal) of high-frequency components; but don't forget to watch that

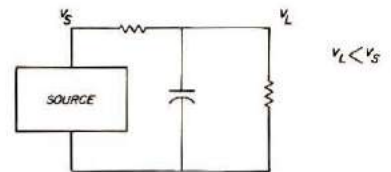

Fig. 4. RC filters eliminate inductors, but at the price of dissipating source energy, at all frequencies, through the series resistor element.

increased internal voltage drop across the filter caused by the series resistor. If your application calls for a load voltage lower than the source voltage, you'll undoubtedly go this route.

Learn to read any filter chart

Now that you understand how a lowpass filter works and what it does, let's examine the results graphically. Fig. 5 is a frequency diagram for a lowpass filter. Note that as the desired frequency increases beyond a certain point, filter output to the load decreases. The frequency at the knee of this curve (where it begins to dip) carries the designation "cutoff frequency," or f_c . This point divides the frequency spectrum into two segments: the passband, to the left, where lower frequencies pass through to the load unattenuated, and the stop band, to the right, where higher-frequency signals see some resistance.

Of course, each filter has its own unique frequency diagram. Component values set f_c , and the number of filter components and sections dictates the slope of the attenuation curve — more elements make for a

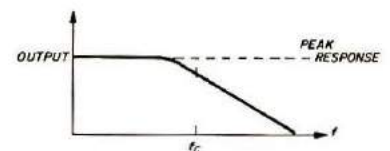

Fig. 5. This frequency diagram shows that in lowpass filters low frequencies encounter almost no resistance, while high frequencies are attenuated greatly. The cutoff frequency, f_c , shows where response begins to change. Note that this graph is only qualitative and merely gives a rough indication of filter performance.

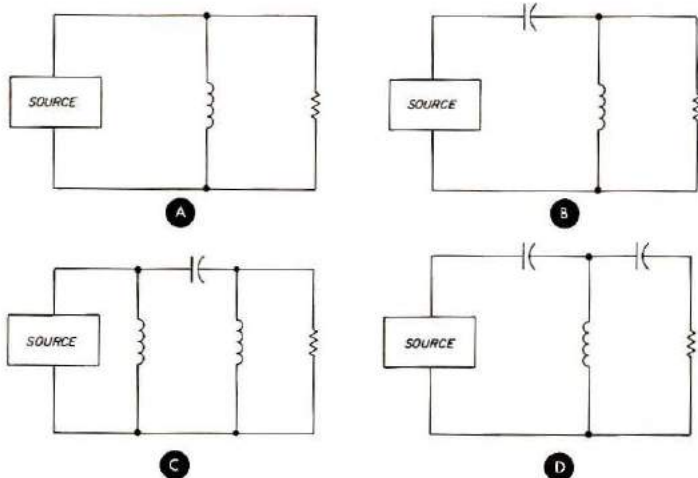

Fig. 6. These simple highpass filters use an inductor to short low frequencies (A); adding a capacitor helps by blocking high frequencies (B); while another input inductor makes a *pi*-section configuration (C). D shows a capacitor input T-section highpass filter.

sharper dropoff. Such diagrams are helpful, because in an instant you can tell what kind of filter you're dealing with and can decide if it will help you in your circuit design.

Highpass reverses the procedure

Let's go back to our original bypass element, but instead of a capacitor, we'll use an inductor (Fig. 6A). Knowing that inductors pass low frequencies with ease, you should quickly realize that this configuration forms a highpass filter. Once again, let's block these low frequencies from the load as well as shunting them around the load; use a capacitor for that blocking (Fig. 6B).

Highpass filters also come in other now-familiar configurations such as the *Pi* section (Fig. 6C) and *T* section (Fig. 6D). Don't look for IC manufacturers who use RL filters; common sense tells us that RL filters do little to save space because you can't miniaturize inductor coils to the chip level.

Highpass filters have frequency diagrams such as that in Fig. 7. The stop band lies to the left while the passband now sits to the right of f_c .

Just for fun, let's place both

a capacitor and an inductor as shunt elements in our bypass element around the load (Fig. 8A). Seems silly? Will the two effects cancel each other? Not at all — take a minute to think about what those elements actually do. The capacitor shorts high frequencies, so the load never sees them, while the inductor does the same to low frequencies. But a certain range of middle frequencies gets sent to the load, hence the name bandpass filter for this arrangement.

Over the years, filter designers have come up with a number of configurations that work well in various bandpass

situations. For a quick look at these see Fig. 8B-C; for a more detailed look, see Reference 2. But in all of them, note the use of inductors and capacitors together to block or short extreme frequency ranges, leaving the middle frequencies for the load.

Let's look at the frequency diagram of a bandpass filter (Fig. 9). Here you'll see a band of mid-range frequencies making up the passband and

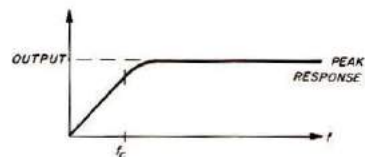

Fig. 7. Highpass filters have a frequency diagram that looks like a mirror image of lowpass filters.

either end constituting sections of the stop band. You might also assume that this diagram describes a shunt filter such as that in Fig. 8A with the inductor determining f_{c1} (shorting low frequencies) and the capacitor across the load determining f_{c2} (shorting high frequencies). But realize that many other configurations could have this identical frequency diagram.

In bandpass cases we can also define the filter bandwidth, the measure of the span of frequencies in the passband.

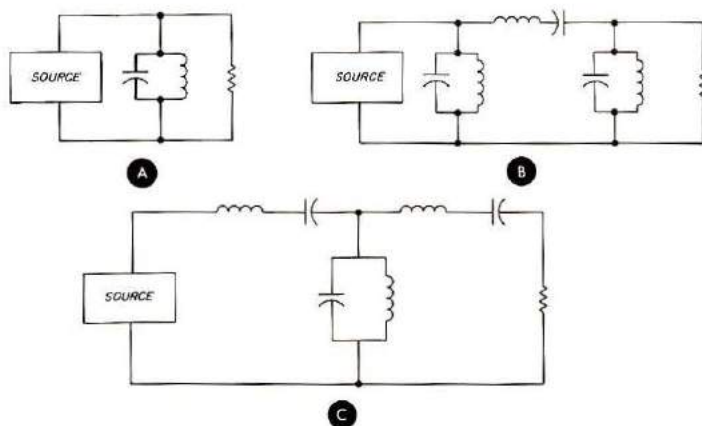

Fig. 8. Bandpass filters join capacitors and inductors in the bypass element (A), to form *pi*-section filters, (B), as well as T-section filters (C).

Look at those points where V_{out} is larger than $1/\sqrt{2}$ (or 0.707) of its maximum value; the distance between these two points defines the filter bandwidth.

Just remember what each component does

Armed with this knowledge, you should be able to pick up any analog circuit schematic and instantly recognize filter configurations, even if you

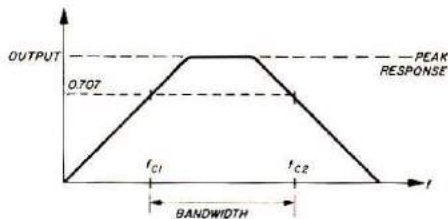

Fig. 9. Frequency diagrams for bandpass filters contain two cutoff frequencies. You can measure bandwidth by looking for those points where signal strength drops to 0.707 of maximum and determining the frequency spread between them.

can't instantly determine their cutoff frequencies. For instance, look for lowpass filters in power supplies, where you want to filter out high-frequency ripple from the dc you just smoothed out from the ac-line power. Look for highpass filters between amplifier sections where you want to amplify information — high frequencies — but not any dc that may have sneaked into the signal, through bias power, for example. Finally, you'll often find mid-range filters in tuning sections where you want only a specific range of signals sent through to later detector and amplifier stages.

References

1. John D. Ryder, *Electronic Fundamentals and Applications*, Prentice-Hall, Inc., Englewood Cliffs, New Jersey, 1970.
2. *The Radio Amateur's Handbook*, American Radio Relay League, Newington, Connecticut, 1977.

HRH

CUSHCRAFT IS THE VHF-UHF ANTENNA COMPANY.

Cushcraft precision engineered VHF/UHF Yagi beams have become the standard of comparison the world over for SSB and CW operation on 6 meters through 432 MHz. Built by skilled craftsmen from the best available materials, these beams represent that rare combination of high electrical performance, rugged construction, and durability.

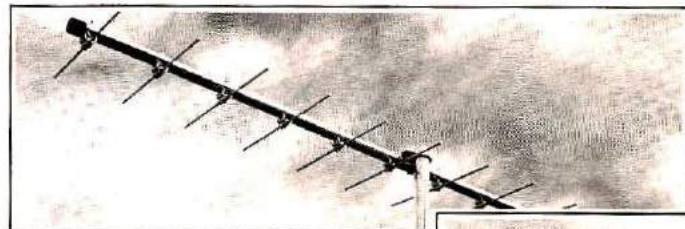

1/2-1 1/4-2 Meter Yagi

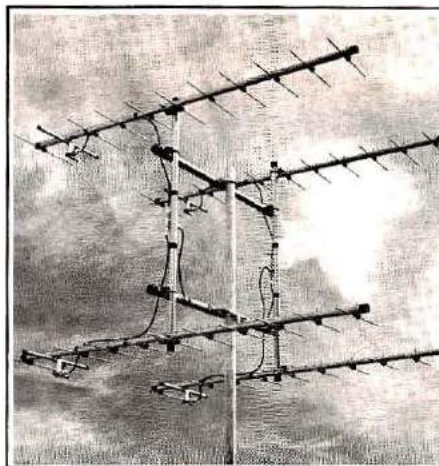

Quad Array

Cushcraft's Quad Arrays for 144, 220, and 432 MHz use four matched 11-element Cushcraft Yagis and are the ultimate in a high-performance Yagi array. These arrays have been carefully engineered for maximum forward gain, high front-to-back ratio, and broad frequency response. All antennas provide a low VSWR match to 50-ohm coaxial feedline.

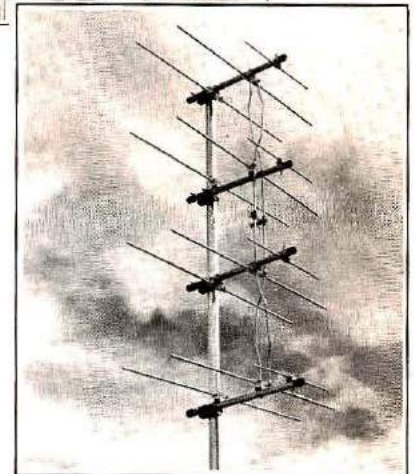

20 Element DX Array

Cushcraft's wide variety of VHF/UHF Beams includes an antenna for every amateur activity above 50 MHz, whether local ragchewing or long-haul over-the-horizon DX. All models have been carefully optimized for maximum forward gain with high front-to-back ratio. The heavy-wall bright hard-drawn aluminum booms and elements are combined with heavy formed aluminum brackets and plated mounting hardware for long operating life and survival in severe weather.



In Stock With Dealers World Wide P.O. Box 4680, Manchester, N. H. 03108

there's a world of difference
in TEN-TEC's *all-new*
hf transceiver—

 OMNI



OMNI—THE ALL-INCLUSIVE. Because OMNI has it *all*. Designed to give you every advantage, every capability, whatever your operating specialty. Designed to give you new conveniences and new levels of performance. Designed to give you the world of Amateur Radio with a world of difference—the OMNI world of unique features. An unusual combination not found in any other.

FUNCTIONAL STYLING. The "look" you requested. "Clamshell" aluminum case clad in textured black vinyl. Complementary nonreflective warm dark metal front panel. Extruded satin aluminum trim bezel and tilt bail. Convenient controls. Fully shielded. And everything in a larger, easier-to-use size: 5¼" h × 14¼" w × 14" d.

TOTALLY SOLID-STATE. Sharing the TEN-TEC heritage of solid-state design leadership with its companion transceivers, the highly successful 540/544, OMNI has all the advantages of proven solid-state technology—reliability, long life, cool performance, better stability.

8-BANDS. The world now and in the future. OMNI covers 160, 80, 40, 20, 15, and 10 meters now (crystals included for all present Amateur bands, 1.8-30 MHz). And it has convertible 10 MHz and "AUX" band positions for the future.

BROADBAND DESIGN. Permits changing bands without tune-up, without danger of out-of-resonance damage to the final stage.

ANALOG OR DIGITAL READOUTS. OMNI-A features an analog dial with 1 kHz dial markings. OMNI-D has 0.43" LED readouts with the 5 most significant in red and the 6th in green to show 100 Hz increments.

BUILT-IN VOX AND PTT. Smooth VOX action with 3 easy-to-adjust front panel controls. PTT control is available at both front and rear panel jacks; an external microphone switch may be used.

BUILT-IN SQUELCH. Unusual in an hf rig, but handy for tuning or monitoring for a net or sked.

BUILT-IN 4-POSITION CW/SSB FILTER. 150 Hz bandwidth with 3 selectable skirt contours for optimum CW reception.

8-POLE CRYSTAL FILTER. 2.4 kHz bandwidth, 1.8 shape factor.

SEPARATE MODE SWITCH. Permits using *all* filters in *any* mode.

2-SPEED BREAK-IN. Switch to "fast" or "slow" receiver muting to accommodate any band condition or mobile operating.

2-RANGE OFFSET TUNING. Switch-select the ±5 kHz range for off-frequency DX work or the ±0.5 kHz range for fine tuning.

OPTIMIZED RECEIVER SENSITIVITY. Ranges from 2 uV on 160 m to 0.3 uV on 10 m (10 dB S+N/N) to achieve ideal balance between dynamic range and sensitivity.

GREATER DYNAMIC RANGE. Typically exceeds 90 dB to reduce possible overload from nearby stations. Also includes switchable 18 dB PIN diode attenuator for additional overload prevention.

WWV RECEPTION. On the 10 MHz band switch position.

FRONT PANEL CONTROL OF LINEAR/ANTENNA BAND-SWITCHING. Auxiliary bandswitch terminals on back panel for simultaneous control of external relays or circuits with the OMNI bandswitch.

BUILT-IN PHONE PATCH JACKS. Provide interface to speaker and microphone audio signals for phone patch connection.

BUILT-IN "TIMED" CRYSTAL CALIBRATOR. In the OMNI-A a pulsed 25 kHz calibrator desensitizes the receiver and provides an automatic 5 to 10 second "on" time for easy two-hand dial skirt adjustment.

BUILT-IN ZERO BEAT SWITCH. Permits placing your transmitted signal exactly on the listening frequencies of CW stations.

BUILT-IN SWR BRIDGE. The "S" meter electronically switches to read SWR every time you transmit to provide a continuous antenna check.

FRONT PANEL MICROPHONE AND PHONE JACKS.

ADJUSTABLE AUTOMATIC LEVEL CONTROL. For setting output power level from low power to full output, for retaining low distortion at desired drive power to linear amplifier.

SEPARATE RECEIVING ANTENNA CAPABILITY. Rear panel switch and jack connect receiving section to common antenna or separate receiving antenna. Also acts as receiving antenna by-pass when used with instant break-in linear amplifiers.

BUILT-IN ADJUSTABLE SIDETONE. Variable pitch and volume.

DUAL COMPRESSION-LOADED SPEAKERS. Larger sound output, lower distortion, no external speaker needed.

POWER INPUT. 200 watts when used with 50 ohm load. Proven, conservatively-rated, solid-state final amplifier design with full warranty for first year and pro-rata warranty for 5 additional years.

100% DUTY CYCLE. Ideal for RTTY, SSTV, or sustained hard usage.

PLUG-IN CIRCUIT BOARDS. For fast, easy field service.

POWER. Basic 12 VDC operation for convenient mobile use; external supply required for 117 VAC operation.

OPTIONAL ACCESSORIES. As all-inclusive as OMNI is, there are a few options: Model 645 Keyer, 243 Remote VFO, 248 Noise Blanker, 252M Power Supply.

Model 545 OMNI-A \$899 Model 546 OMNI-D \$1069

Experience the world of difference of OMNI, see your TEN-TEC dealer or write for details.



TEN-TEC, INC.
SEVIERVILLE, TENNESSEE 37862
EXPORT 5715 LINCOLN AVE., CHICAGO, ILL. 60646



- | | | |
|---|--|--|
| <p>1 Receiver RESONATE control for peak sensitivity.</p> <p>2 Receiver Dual Range OFFSET TUNING control for off-frequency work.</p> <p>3 ZERO BEAT switch; spring-loaded, momentary contact.</p> <p>4 6-Digit LED FREQUENCY READOUT for 100 Hz accuracy.</p> <p>5 OFFSET TUNING LED indicates OT switch is "on".</p> <p>6 MAIN TUNING KNOB; big, easy-to-grip with integral spinner.</p> <p>7 AUTOMATIC LEVEL CONTROL LED indicates ALC-region operation.</p> <p>8 Combination "S" and SWR METER; switches automatically.</p> | <p>9 Combination ALC control and NOISE BLANKER on/off switch.</p> <p>10 DRIVE control for final stage.</p> <p>11 SQUELCH combination on/off switch and control.</p> <p>12 4-Position SELECTIVITY switch for SSB and CW.</p> <p>13 4-Position MODE switch; automatic SSB Normal, Reverse, CW, and Lock (key down).</p> <p>14 Combination push-pull POWER switch and AUDIO LEVEL control.</p> <p>15 Combination RF ATTENUATOR on/off switch and control.</p> <p>16 VOX GAIN control.</p> | <p>17 VOX DELAY control.</p> <p>18 VOX ANTI-TRIP control.</p> <p>19 11-Position BAND SWITCH.</p> <p>20 MICROPHONE jack; hi-z input.</p> <p>21 HEADPHONES jack.</p> <p>22 RECEIVER OFF-SET TUNING SWITCH; 3-position: Max-Min-Off.</p> <p>23 VOX-PTT SWITCH.</p> <p>24 QSK (full break-in) SWITCH; 2-position: Fast-Slow.</p> |
|---|--|--|

BY JOHN TYSKEWICZ, W1HXU

"Simplex" has been the universal trademark for just about every kind of device with good sales appeal; namely, low cost and satisfactory performance. This 10-15-20-meter beam with its plain construction and inexpensive materials meets our simplex specifications. Whenever an

possible when using separate wire elements and a common feed line.¹ This design eliminates trap construction, and loading coils are unnecessary in a short dipole if the excess wire is allowed to droop or is folded inward. Score another big plus.

The dipole formula

The magic number 143 is

numbers are as follows: the numerators in eq. 1 for the 10-, 15-, and 20-meter amateur bands (dimensions in meters) are 157, 153, and 148. (If you're still using the antiquated English system of measurement, the new numbers for eq. 2 are respectively 516, 502, and 486.) The shorter span of this antenna results in some loss of

THE SIMPLEX 3-BAND WIRE BEAM

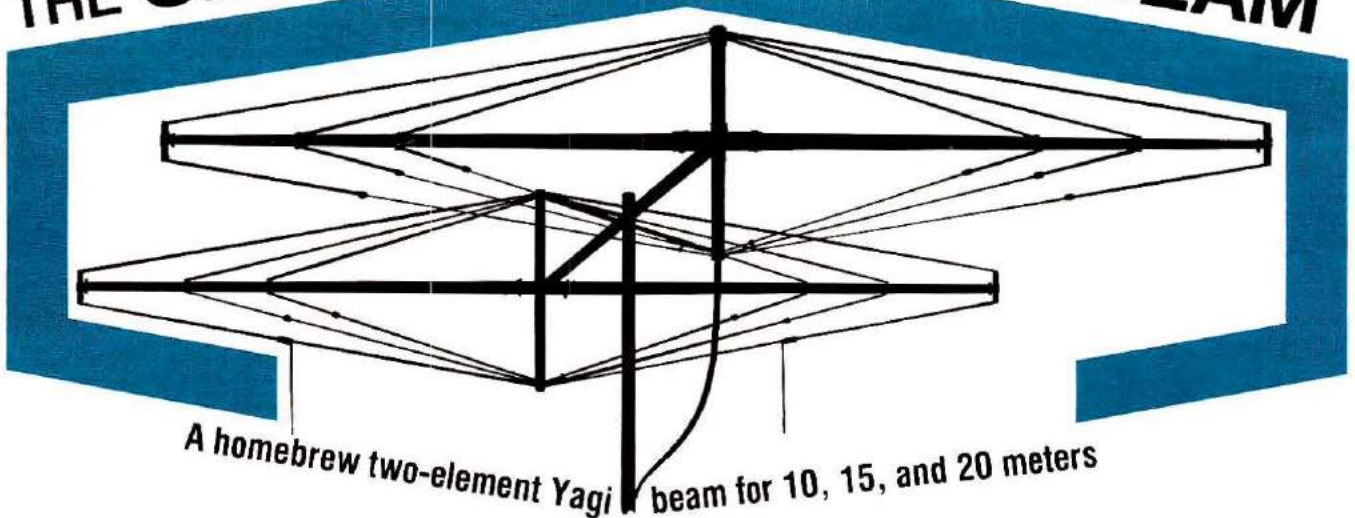

antenna configuration differs from the original or standard type it's interesting to speculate if much has been gained or lost. Well, the first big plus in this antenna is a substantial reduction in the overall span dimension, or space requirement. Additional advantages are lower stress load at the fittings, greater handling ease, and better environmental appearance.

Maximum radiation occurs from the high-current or middle portion of a half-wavelength dipole, while the outer ends carry low current and high voltage. Previous beam antenna work indicated that excellent frequency bandwidth is

used in the straight dipole formula when the antenna length is in meters:

$$L \text{ (meters)} = \frac{143}{f \text{ (MHz)}} \quad (1)$$

where f is the frequency. In English terms the equation is:

$$L \text{ (feet)} = \frac{468}{f \text{ (MHz)}} \quad (2)$$

The numerator in this equation changes when the antenna outer ends are folded inward. The number varies with the percentage of wire folded, the enclosed angle of the elements, and the proximity of the elements to other wires.

For the driven element of the simplex antenna the new

radiation efficiency. But, from my viewpoint, the advantages outweigh the debits, so let's get going.

Construction

Fig. 1 shows the dimensions of the driven element, feed-conductor block, and the outer, or 20-meter, PVC insulator. The bamboo pole tips were reinforced with wood inserts and epoxy glue. Using a coarse, flat file, the tips were carefully rounded to fit the PVC Tee fitting. Before final attachment, coat and seal the tip with model cement.

The bamboo spreaders can now be spiral wrapped with 19-mm (0.75-inch) wide paper

masking tape. Give them two coats of latex house paint. At the 10- and 15-meter tubular PVC insulator locations, spiral wrap five turns of PVC electrical tape over an area 2.5-cm (1-inch) wide. The PVC insulation is adequate because the parts are some distance from the high-voltage ends of the wire. The 10- and 15-meter PVC insulators (**Fig. 2**) were notched with a coarse, round file to a radius slightly smaller than that of the spreader.

To force-fit the 20-meter-band insulator tube into the Tee fitting, an inner stop ridge must be removed with a narrow chisel or boring tool. The 10- and 15-meter band PVC insulators are attached to the spreader with 1.3-mm (AWG no. 16) plated iron wire, which should be tinned for better rust protection. Use a soldering iron, 50-50 solder, and a strong flux, such as acid plus paste, applied with a swab.

The wire-forming sequence shown in **Fig. 2** (ABC) was begun by making a central loop around a nail gripped in a vise. The preformed wire was banded around the spreader and PVC tube, the loose ends tightly drawn with pliers and

twisted. The wire was checked for square fit before the final twisting. Excess wire was clipped off and the adjacent looped wire was twisted. The 10-meter-band insulators were attached to the inner side of the beam, while the 15-meter-band insulators were attached at the outer sides. The assembled 20-meter-band insulator was anchored at the tip with a 1-1/2-turn copper wire band and twisted joint (see **Fig. 1**).

Before painting the wood-nylon spreader, a flat spot, 9.3 mm (0.375 inch) wide by 5.8 cm (2.25 inches) long was sawed out for the connector block. All of the holes were drilled through the corner edges of the pylon that will be fastened to the completed spider, **Fig. 3**, with four M 3.5 (no. 6-32) screws. Several layers of friction tape were wrapped around the bamboo poles at the clamping spots for a firm fit against the angle iron and wire rigging.

The folded lower wires were connected to the pylon with 36-45 kg (80-100 lb.) nylon monofilament fishing line separated by small ceramic insulators. The nylon at the pylon end was attached to 1.3-

mm (no. 16 AWG) copper wire leaders 25.4 cm (10 inches) long to simplify tension adjustments. The line handles like a slippery eel; for knot tying, consult an expert fisherman, seaman, or Boy Scout.

The length of the folded wire was measured from the bottom edge of the PVC tube to the ceramic insulator. The spreaders were kept in a straight line perpendicular to the pylon spreader. At the ceramic insulator, leave an extra 15 cm (6 inches) of wire after making a wrap joint. The wire is wound in a coarse spiral along the folded wire.

Fig. 2 shows the reflector element, 10- and 15-meter band PVC insulator, and wire-clamping method. The single-piece reflector wires go through the top wire holes of the pylon, and the lower folded wires are longer than the driven-element wire.

Fig. 3 is an all-metal project requiring a bit of hack-sawing and drilling. Except for the fasteners, all of the iron, pipe, and EMT steel conduit was found at a scrap metal yard. The 19-cm (0.75-inch) iron pipe may require some file work to smooth off the high spots to fit into the EMT. Not all home workshops have an arc welder; the finished pieces can be taken to a job-shop or auto-muffler garage to be done while you wait.

The clamp material should be rust-proof — preferably stainless steel, brass, or galvanized steel (tin the exposed, sheared edges). Form the clamp so that, when fully closed around spider and spreader, the exposed gap at the fastener does not exceed 6.4 mm (0.25 inch).

To make use of what looked like wasted space a second 10-meter-band reflector filled in the bottom span, thereby improving the front-to-back ratio. The ceramic insulator connecting the 10- and 20-

The three-band simplex antenna uses wire elements which also act as bracing for the horizontal support arms. This type of construction should stand up well under wind and icing conditions. The driven elements are to the left, with the coaxial cable falling away at a slight angle to the tower.

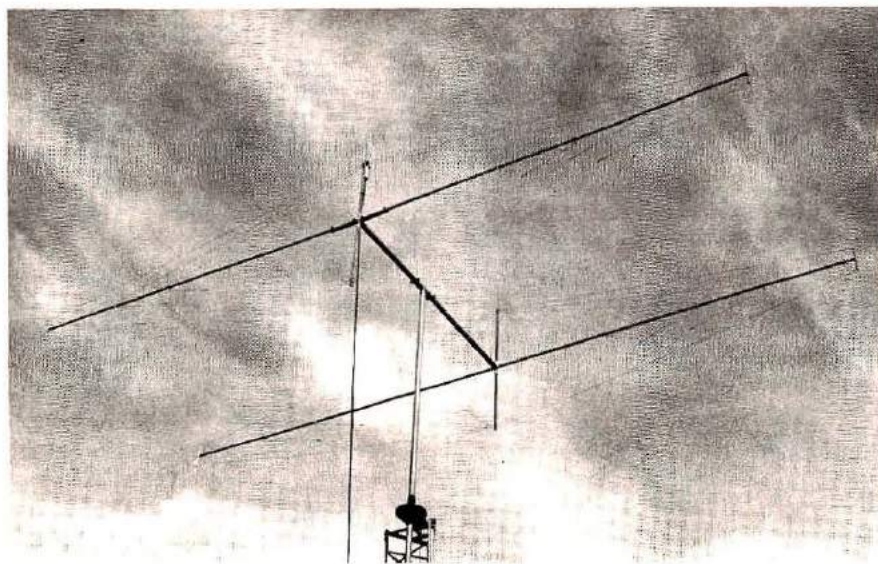

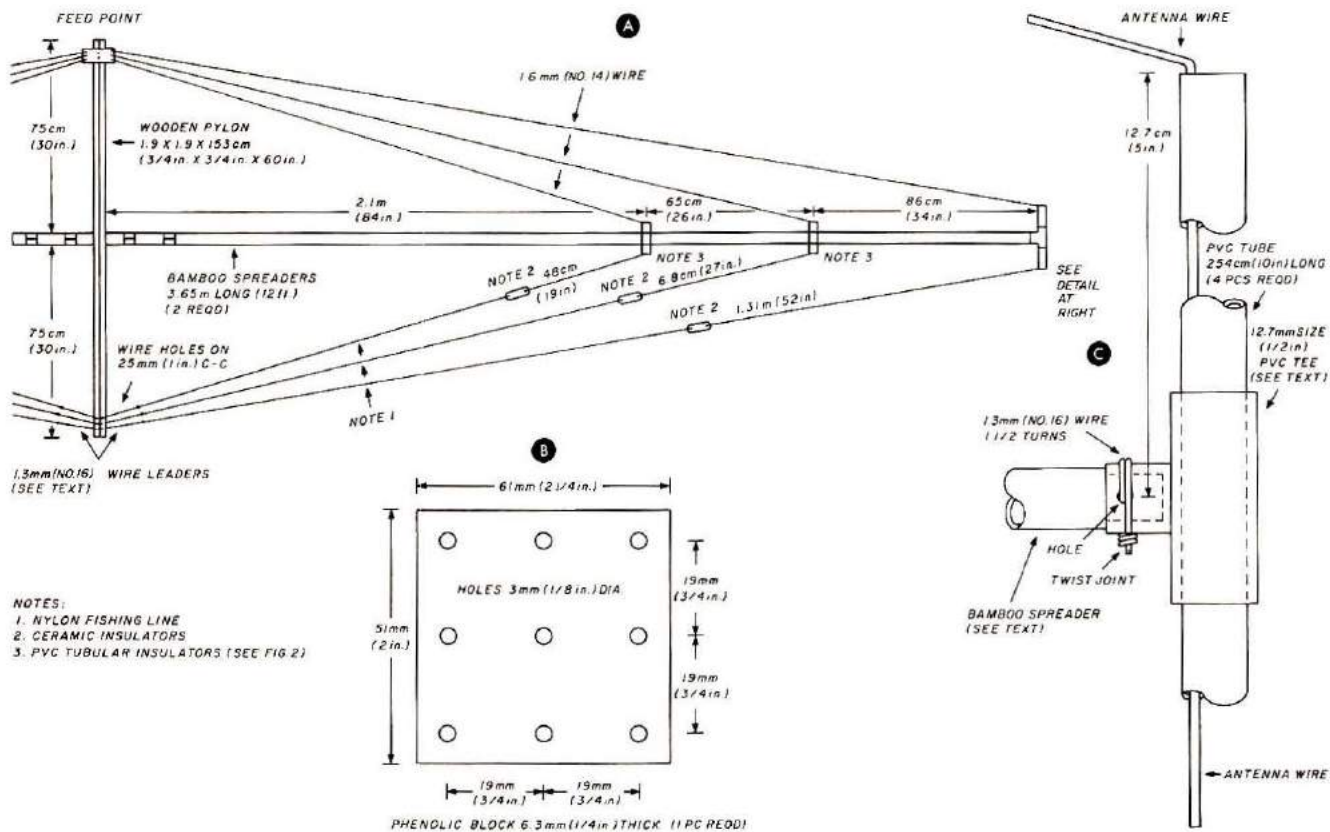

Fig. 1. Dimensions for the driven element, A, feed connector block, B, and the outer insulator, C, for the 20-meter band.

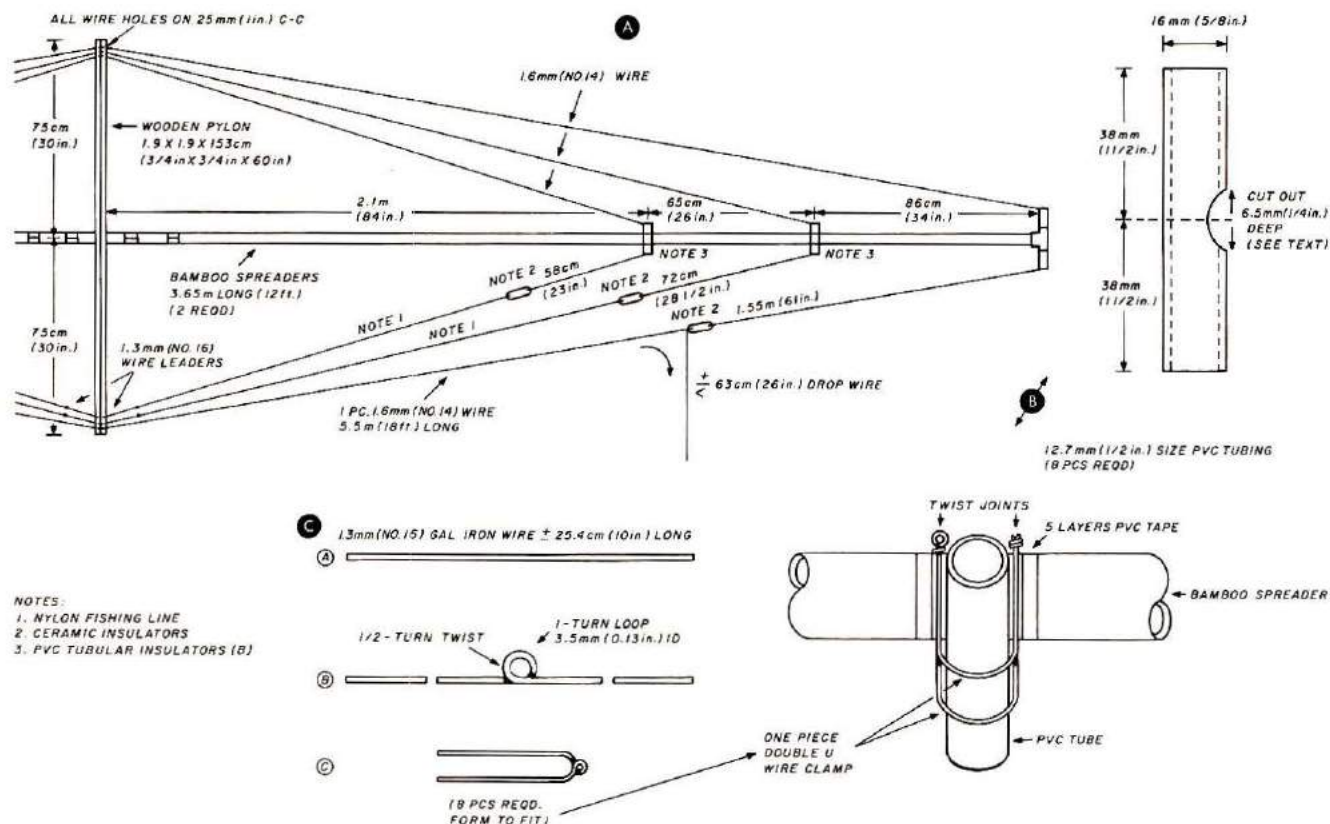

Fig. 2. Dimensions for the reflector element, A, 10- and 15-meter band insulator, B, and wire-clamping method, C. Abbreviations: C-C, center-to-center; MS, machine screw.

meter-band wires must be at least 10 cm (4 inches) long; the type used in an open-wire feed line is just right.

The alert reader may question the rather short 15-meter-band reflector. After the bottom 10-meter-band reflector was installed some form of secondary loading effect apparently occurred, and the

a single length of RG-8/U coaxial cable and wire elements in parallel. Jumper wires were soldered to the antenna wires at both sides of the connector block close to the wire joint, then connected to a 1:1 balun.

No attempt was made to tune the elements near ground level because my tower has a

reflector-wire length is made to the same ratio, driver vs. reflector, as shown.

Closing comments

With the indicated dimensions the driven elements peaked at 28.3, 21.15, and 14.1 MHz, which covers the CW and lower end of the phone bands. If optimum CW or phone

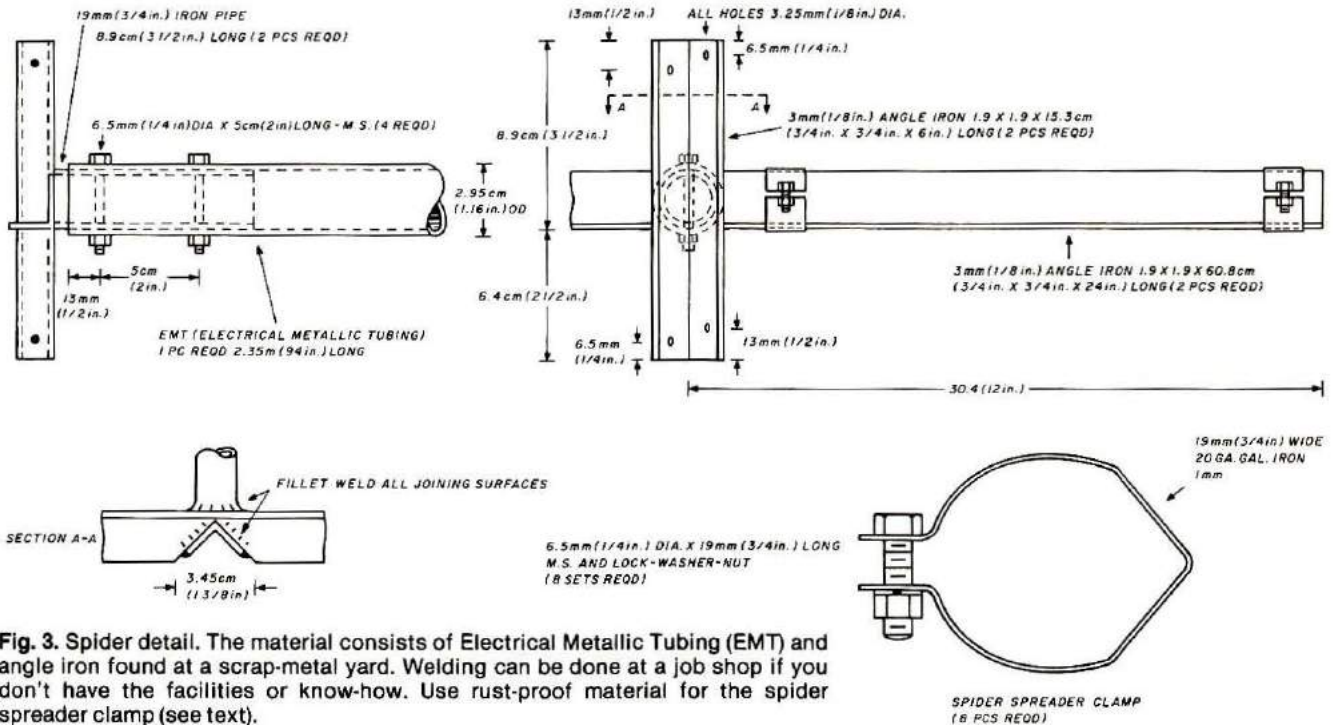

Fig. 3. Spider detail. The material consists of Electrical Metallic Tubing (EMT) and angle iron found at a scrap-metal yard. Welding can be done at a job shop if you don't have the facilities or know-how. Use rust-proof material for the spider spreader clamp (see text).

15-meter-band reflector was shortened.

At the top of the pylon, solder a jumper wire to the 20-meter-band wire, then carry jumper wire across pylon to the 15-meter-band wire and solder. Then go to the 10-meter-band wire and solder. Finally, lock the spreaders by creasing wire at the PVC tube ends, as was done for the driven element.

Feeding and adjustment

In its installation, the coax cable drops directly downward from the beam for some distance. Therefore, the boom was attached to the rotatable mast 15 cm (6 inches) off center, or closer to the driven element. The feed method uses

rapid-acting foldover mechanism. Resonant frequency of the driven element was determined with a noise bridge. Tests at low power showed the swr and relative field strength. If your beam happens to tune too high in frequency, unwind that extra 15-cm (6-inch) length of wire at the lower folded section and extend it toward the pylon. If the element tunes too low, the only recourse is to shorten the lower section.

By using a tuner and experimenting with the coax length, acceptable performance can be obtained. Usually the same coax length works out for the 10- and 20-meter band. A different length is required for the 15-meter band. The

segments are desired, use the new factor numbers in eq. 1 for a new wire-length dimension. Top off by creasing or bending the antenna wire where it enters and leaves the PVC tubing to the lock spreaders. If high winds are prevalent, secure the antenna wire to the PVC tube with light-gauge copper wire through a small hole at the tube ends.

If an ambitious constructor tacks on a director element, the three-element version could be called Super-Simplex.

Reference

1. John Tyskewicz, W1HXU, "Tri-Band Wire Yagi," *Ham Radio Horizons*, December, 1977, page 26.

HRH

DSI COMMUNICATIONS SERIES

1.3GHz — 1GHz — 700MHz



MODEL C1000 10Hz to 1GHz

\$399⁹⁵

- AUTO ZERO BLANKING
- AUTO DECIMAL POINT

Accuracy . . . that's the operational key to this rugged advanced design Model C1000 1GHz frequency counter . . . a significant achievement from DSI. That's because you get . . . **.1 PPM** 0° to 40°C proportional oven time base . . . Built in 25DB preamplifier with a 60DB adjustable attenuator . . . x10 & x100 audio scaler which yields .01 Hz resolution from 10Hz to 10KHz equivalent to 10 sec. & 100 sec. Gate Time . . . Selectable .1 & 1 sec. time base and 50 ohms or 1 meg ohm input impedance . . . Built-in battery charging circuit with a Rapid or Trickle Charge Selector . . . Color keyed high quality push button operation . . . All combined in a rugged black anodized (.125" thick) aluminum cabinet. The model C-1000 reflects DSI's on going dedication to excellence in instrumentation for the professional service technician, engineer, or the communication industry.

MODEL C700 50Hz to 700MHz

\$299⁹⁵

- AUTO ZERO BLANKING
- AUTO DECIMAL POINT

ALL NEW! All UNPARALLELED DSI QUALITY! The model C 700 700 MHz frequency counter features . . . **.2 PPM** 0° to 40° C proportional oven time base . . . 25db preamplifier with a 60db adjustable attenuator. Built in battery charger with a rapid or trickle charge selector . . . Combined in a rugged (.125" thick) aluminum cabinet makes the C700 ideal for the communication industry and professional service technician.

3600A OWNERS: Up date your 3600A frequency counter to a C 700 includes, new back board, **.2PPM** proportional oven, 25db preamplifier, rugged .125" thick aluminum cabinet, order 3600A-700. Unit must be returned to DSI factory for modification.

DSI — GUARANTEED SPECIFICATIONS — FACTORY ASSEMBLED — MADE IN USA

Model	Frequency Range	Proportional Oven Accuracy Over Temperature	50Hz To 75MHz	75MHz To 500MHz	500MHz To 1GHz	Number Of Digits	Size Of Digits	Power Requirements	Size
C700	50Hz to 700MHz	.2PPM 0° to 40°C	50MV	10MV	NA	8	.5 Inch	115 VAC-BATT 8 to 15VDC	3"H x 8"W x 6"D
C1000	10Hz to 1GHz	.1PPM 0° to 40°C	20MV	1MV	>50MV	9	.5 Inch	115VAC-BATT 8 to 15VDC	4"H x 10"W x 7½"D

— All Units Are Factory Assembled, Tested And Carry A Full 5 Year Limited Warranty —

- NO EXTRA COSTS •

FREE Shipping anywhere in U.S.A. & Canada. All other countries, Add 10%.

Strongest warranty in the counter field.
Satisfaction Guaranteed.

See Your Dealer
OR

Call Toll Free (800) 854-2049 **DSI Instruments, Inc.**
California Residents, Call Collect (714) 565-8402

VISA • MC • AMERICAN EXPRESS • CHECK • MONEY ORDER • COD
7914 Ronson Road, No. G, San Diego, CA 92111

Model C 700	\$299.95
3600A-700 Factory update (3600A only) Includes Labor & Re-Calibration	\$124.95
Model C 1000	\$399.95
Opt. 01 1.3 GHZ (C1000 only)	\$ 99.95
Opt. 02 .05 PPM 10MHz Double Oven 0° to 50° C Time Base (C1000 only)	\$129.95
Opt. 03 20 Hr. rechargeable Battery Pack	\$ 29.95
Ant. 210 Telescopic Ant./BNC Adapter	\$ 9.95

DSI Instruments Inc.

Performance You Can Count On



MODEL 3550W
\$149.95
INCLUDES TCXO ± 1 PPM



MODEL 3600A
\$199.95
INCLUDES OVEN TIMEBASE $\pm .5$ PPM



MODEL 3240HH
\$119.95
BATT. OPERATED

The 3600A, 3550W and 3240HH Frequency Counters represent a significant new advancement, utilizing the latest LSI Design ... which reflects DSI's ongoing dedication to excellence in instrumentation, for the professional service technician and amateur radio operator. Before you buy a DSI instrument you know that the specification is. We publish complete and meaningful specifications which state accuracy over temperature and sensitivity at frequencies you need. And we guarantee those specifications in writing. **JOIN THE RANKS OF THOUSANDS OF SATISFIED CUSTOMERS. PLACE YOUR ORDER TODAY AND BE THE ONE ON FREQUENCY.**

DSI — GUARANTEED SPECIFICATIONS — MADE IN U.S.A.

Model	Frequency Range	Accuracy Over Temperature	@150MHZ	@250MHZ	@500MHZ	Number Of Readouts	Size Of Readouts	Power Requirements	Size
3600A	50HZ-600MHZ	OVEN .5PPM 50° to 100°F	10MV	10MV	50MV	8	.5 inch	115VAC or 8.2-14.5VDC	2 1/8" H x 8" W x 5" D
3550W	50HZ-550MHZ	TCXO 1PPM 65° to 85°F	25MV	25MV	75MV	8	.5 inch	115VAC or 8.2-14.5VDC	2 1/8" H x 8" W x 5" D
3240HH	2MHZ-250MHZ	3PPM 65° to 85°F	100MV	100MV	NA	7	.4 inch	4AA Batt.	5" H x 3" W x 2" D

**ALL UNITS ARE FACTORY ASSEMBLED,
TESTED AND CARRY A FULL 1 YEAR WARRANTY.**

See Your Dealer
OR

Call Toll Free (800) 854-2049 DSI Instruments, Inc.

California Residents, Call Collect (714) 565-8402

VISA • MC • AMERICAN EXPRESS • CHECK • MONEY ORDER • COD
7914 Ronson Road, No. G, San Diego, CA 92111

• NO EXTRA COSTS •

FREE Shipping anywhere in U.S.A.
& Canada. All other countries, Add \$10.00.
Strongest warranty in the counter field.
ONE YEAR Parts and Labor
Satisfaction Guaranteed.

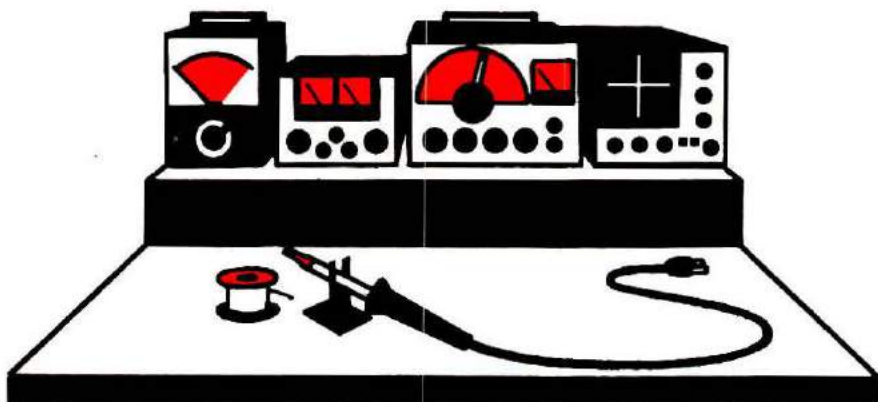

BENCHMARKS

Low-Power RF Test Equipment

Checking the output of low-power vhf equipment can be a bit troublesome, particularly if problems are encountered in the field, and no small dummy load or field-strength meter is available. Test equipment for CB rigs

ductive, carbon types, whereas the 25-kilohm control may be of any type. Component values are not critical, as long as the transmitter "sees" a 50-ohm load at its output terminals. Any available meter from about 100 μ A up to 1 or 2 mA could be used without difficulty. Keep leads short!

VHF field-strength meter

This unit is good for low-power 50, 144, and 220 MHz work, and is about as simple as they come, Fig. 2. The tuned circuit is formed from a 38-mm (1-1/2-inch) piece of 1.6-mm (No. 14) or 1.3-mm (No. 16) copper wire bent into a U shape so that its terminals meet those of a Radio Shack No. 272-1341 miniature 365-pF variable capacitor. The pickup probe is simply a 25 to 50 cm (10 to 20 inch) piece of 3.3 to 2.1 mm (No. 8 to 12) wire, soldered to the center of the U and run through a small grommet installed in the top of whatever case is used; its length can be adjusted for best sensitivity

on the most-used band. A 50-microampere meter will give best results at low power levels, but anything up to about 1 mA will do the job, though at reduced overall sensitivity.

This field-strength meter is pretty-much self-supporting due to its construction, and can be housed in practically any kind of case, such as a small plastic mini-box.

Karl T. Thurber, Jr., W8FX

Rooftop Identification

Put your call letters on the roof of your car or truck to make it easier to spot from the air. After I did so, I was spotted by aircraft I'd contacted on 2-meter fm.



Many city police departments and highway patrols now use planes and helicopters for traffic control and surveillance — your stolen vehicle will be much easier to spot if you have highly visible identification on the roof.

John Korbelik, K70CG

Identifying wire size

Often it is desirable to determine the size of wire obtained from surplus sources, or to be used in duplicating coils, chokes, or rewinding transformers. It is especially difficult to identify the size of the smaller numbered wire.

The size of any wire may be easily determined by the following method: first, temporarily close-wind the wire onto a ruler to cover exactly one inch; next, unwind the wire while counting the number of turns.

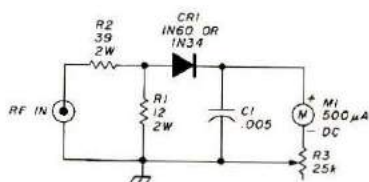

Fig. 1. The schematic diagram for a low-cost, low-power, rf output indicator. Keep leads short, especially those of R1 and R2. Build it in a small metal enclosure, and use almost any meter in the range of 100 μ A up to 1 mA or so; the lower range will be more sensitive to low power.

can be used in a pinch, but they often won't work well for vhf. I developed the following two circuits specifically for low-power field testing.

Dummy load and rf-output meter

This circuit, Fig. 1, can be used with handheld or mobile rigs up to 4 or 5 watts output with no trouble. The unit should be built in a small metal case and fitted with connectors to match the equipment's output jacks. The 39- and 12-ohm resistors should be 2-watt, nonin-

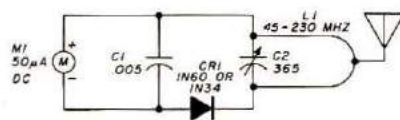

Fig. 2. This field-strength meter is inexpensive and simple. It will work from approximately 45 to 230 MHz. L1 is a U-shaped piece of wire, soldered to the terminals of an inexpensive broadcast-band variable capacitor. The length of probe wire soldered to the center of the U can be varied for best pickup.

Finally, refer to the copper wire tables, found in most handbooks. In the "turns per linear inch" column, locate the number of turns you have counted. The wire size appears opposite, in the "wire size" column.

Gene Brizendine, W4ATE

Handy Stand

Here is an easily made stand for the hand-held transceivers commonly used with vhf repeaters. The stand puts the antenna and speaker in an almost vertical position — just right for monitoring or transmitting. Incidentally, note that a whip antenna is being used as sug-

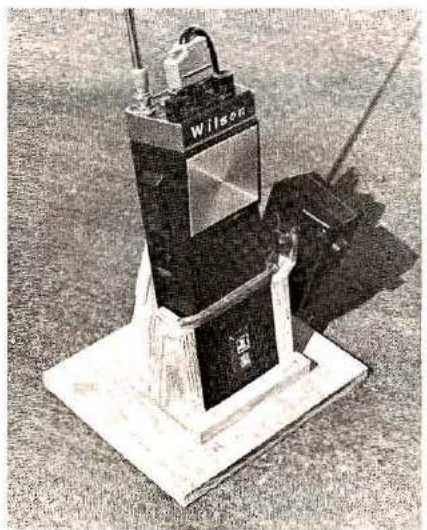

gested to me by W1MPD. The whip far outperforms the "rubber-ducky" type antenna.

The original stand was made from fir plywood; any similar material can be used. The radio is held in position with a large rubber band — several small ones would do. A clip for a hand-held microphone/speaker can be added as shown. A couple of thin strips of scrap wood should be glued along the back support to make it easier to grasp and carry the stand when the transceiver is in it. The stand was assembled with 19-mm (3/4-inch) brads and white glue.

George A. Wilson, W1OLP

Reliability — Service — Experience

YAESU



FT-227R
144-148 MHz 800-CHANNEL
"MEMORIZER" \$315

KENWOOD



TS-520S
160-10M TRANSCEIVER
Buy your TS-520S from us for \$739 and we will include an MC-50 microphone and CW-520 filter FREE.

DRAKE



Tr-7 SYSTEM
HF TRANSCEIVER
... WRITE FOR QUOTE

NOW IN STOCK

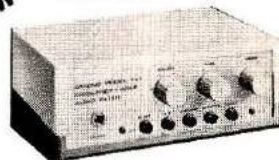

DATONG MODEL FL-1
FREQUENCY-AGILE
AUDIO FILTER
IMMEDIATE DELIVERY \$179**
PRE-PAID

Please include your area code and telephone number with any correspondence.



RSE HAM SHACK

1207 W. 14 MILE, CLAWSON, MICHIGAN 48017
313-435-5660



The Ultimate IAMBIC PADDLE...

- Full range of adjustment in tension and contact spacing
- Self-adjusting nylon and brass needle bearings
- Solid silver contact points
- Precision-machined, chrome plated brass frames
- Heavy steel base has black, textured finish (chrome plated base optional)
- Non-skid feet



Write for literature

Available at selected dealers or send \$39.95 (\$49.95 for chrome model) plus \$2.00 shipping and handling. Money-back guarantee.

BENCHNER, INC.
Dept. A, 333 W. Lake St., Chicago, IL 60606
(312) 263-1808

ALL BAND TRAP ANTENNAS!



PRETUNED - COMPLETELY ASSEMBLED - ONLY ONE NEAT SMALL ANTENNA FOR UP TO 6 BANDS! EXCELLENT FOR CONGESTED HOUSING AREAS - APARTMENTS LIGHT - STRONG - ALMOST INVISIBLE!

FOR ALL MAKES & MODELS OF AMATEUR TRANSCEIVERS - TRANSMITTERS - GUARANTEED FOR 2000 WATTS SSB 1000 WATTS CW. FOR NOVICE AND ALL CLASS AMATEURS!

COMPLETE AS SHOWN with 90 ft. RG58U-52 ohm feedline, and PL259 connector, insulators, 30 ft. 300 lb. test dacron end supports, center connector with built in lightning arrester and static discharge - molded, sealed, weatherproof, resonant traps 1" X 5" - you just switch to band desired for excellent worldwide operation - transmitting and receiving! WT. LESS THAN 5 LBS.

80-40-20-15-10 bands 2 trap --- 102 ft. with 90 ft. RG58U - connector - Model 998BU ... \$49.95
40-20-15-10 bands 4 trap --- 54 ft. with 90 ft. RG58U coax - connector - Model 1001BU ... \$48.95
20-15-10 bands 2 trap --- 26 ft. with 90 ft. RG58U coax - connector - Model 1007BU ... \$47.95

SEND FULL PRICE FOR POST PAID INSURED DEL. IN USA. (Canada is \$5.00 extra for postage - clerical - customs - etc.) or order using VISA Bank Americard - MASTER CHARGE - AMER. EXPRESS. Give number and ex. date. Ph 1-308-236-5333 9AM - 6PM week days. We ship in 2-3 days. PRICES MAY INCREASE SO - ORDER NOW AND SAVE! All antennas guaranteed for 1 year. Money back trial! Made in USA. FREE INFO. AVAILABLE ONLY FROM.

WESTERN ELECTRONICS

Dept. AH-11

Kearney, Nebraska, 68847

**Because K6SSS
loves DX,
his neighbors sent him
on a little expedition.**

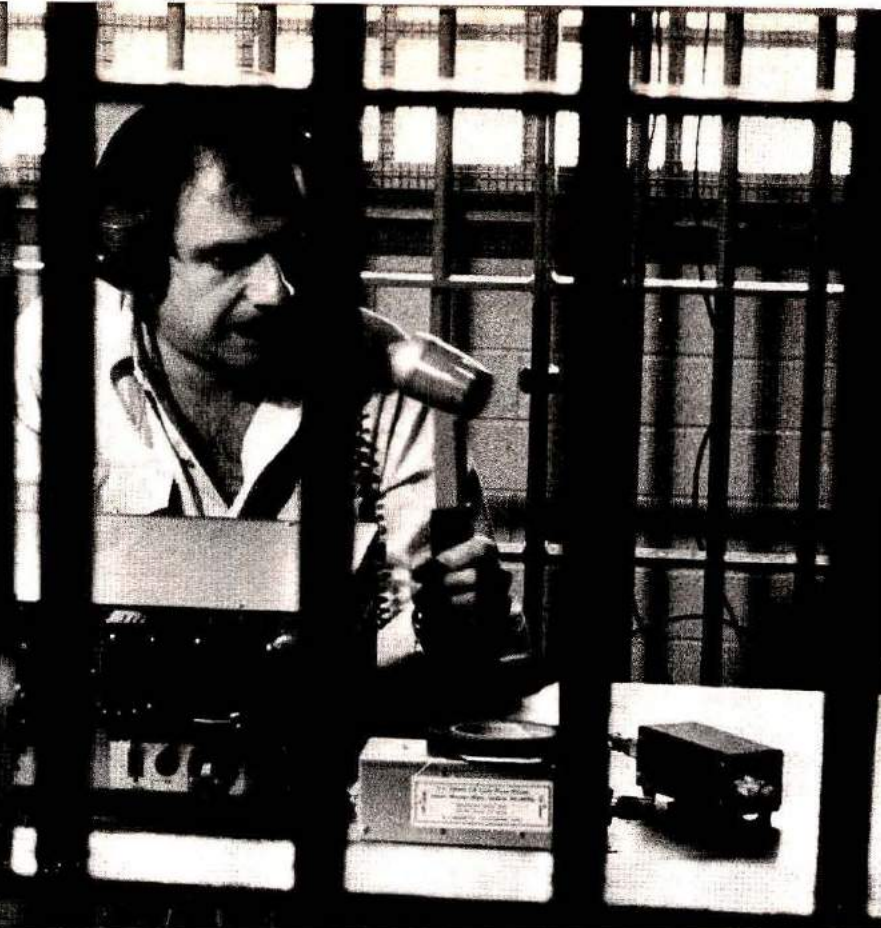

One neighbor sued him for interfering with Lawrence Welk. Another filed a complaint about that "monstrosity" in his backyard—a tribander at 40 feet.

7,781 tangled with the law

The K6SSS case is an example of what can happen to you these days. No matter where you live. It is hypothetical. But real lawsuits are being fought right now by people like K50VC, W2LTP, WB7NOM, W8NRM and W6UFJ/N6QQ to name a few. Last year nearly 8,000 unsuspecting hams and CB'ers ran afoul of the law. Sure, they're taking their fight to court—but they're losing! Never mind that they've got building permits for their towers. Or that the FCC says their rigs are "clean." Judges are ruling against them. The alarming part is that every suit lost makes it that much easier to nail the next guy. Prosecuting attorneys love to cite recent adverse decisions during a trial.

Legal ammunition available

The tragedy is that suits are being lost that could have been won. But TVI/RFI and tower cases fall into a little-known area of the law. Unless your lawyer is a specialist, he could spend hundreds of hours researching court decisions. And still not be sure he's put together the strongest defense possible. It's expensive (expect to spend an average \$4,000 to \$8,000 if you're sued). And risky. Which is why we formed the non-profit Personal Communications Foundation* To provide your lawyer with legal ammunition.

Who we are

We're a handful of ham lawyers, professors and judges (all volunteers) who wanted to help before it's too late. We're putting together the first research library of personal communications and zoning law. And having briefs written by the best legal brains. It's all available to your lawyer. For 10¢ a page. We can't guarantee you'll win. We can't try the case for you. But if you or your lawyer contacts us, we'll sure make sure you get a fighting chance.

Give us a fighting chance

To be even more successful in future battles, we're building an arsenal of weapons to use in court. For example, we're commissioning a study by real estate experts on the effect of a backyard tower on neighborhood property values. The pricetag is a stiff \$11,000. But without the study, more cases will be lost. And more dangerous precedents will be set.

We are winning. But it takes money to keep fighting. You can help us fight by sending a check. The ARRL did. Think of us as your insurance policy against a lawsuit. All checks are 100% tax-deductible.

Please act today. We've already got a late start.

*Non-profit Cal. membership corp #788-085

Kenneth S. Widelitz, WA6PPZ, President
Personal Communications Foundation*
Suite 1504
10960 Wilshire Blvd.
Los Angeles, CA 90024 (213) 478-1749

I want to give you a fighting chance. Enclosed is my 100% tax-deductible membership application.

- Life member \$250 Contributing member \$100
- Full member \$25 Associate member \$10

All members receive our free legal kit and newsletter

name _____ call _____

address _____

city _____ state _____ zip _____

PCF  Personal Communications Foundation
Defending the rights of hams

(space donated by the publisher)

BREAKS THROUGH EVERY HF SOUND BARRIER --INSIDE AND OUT!

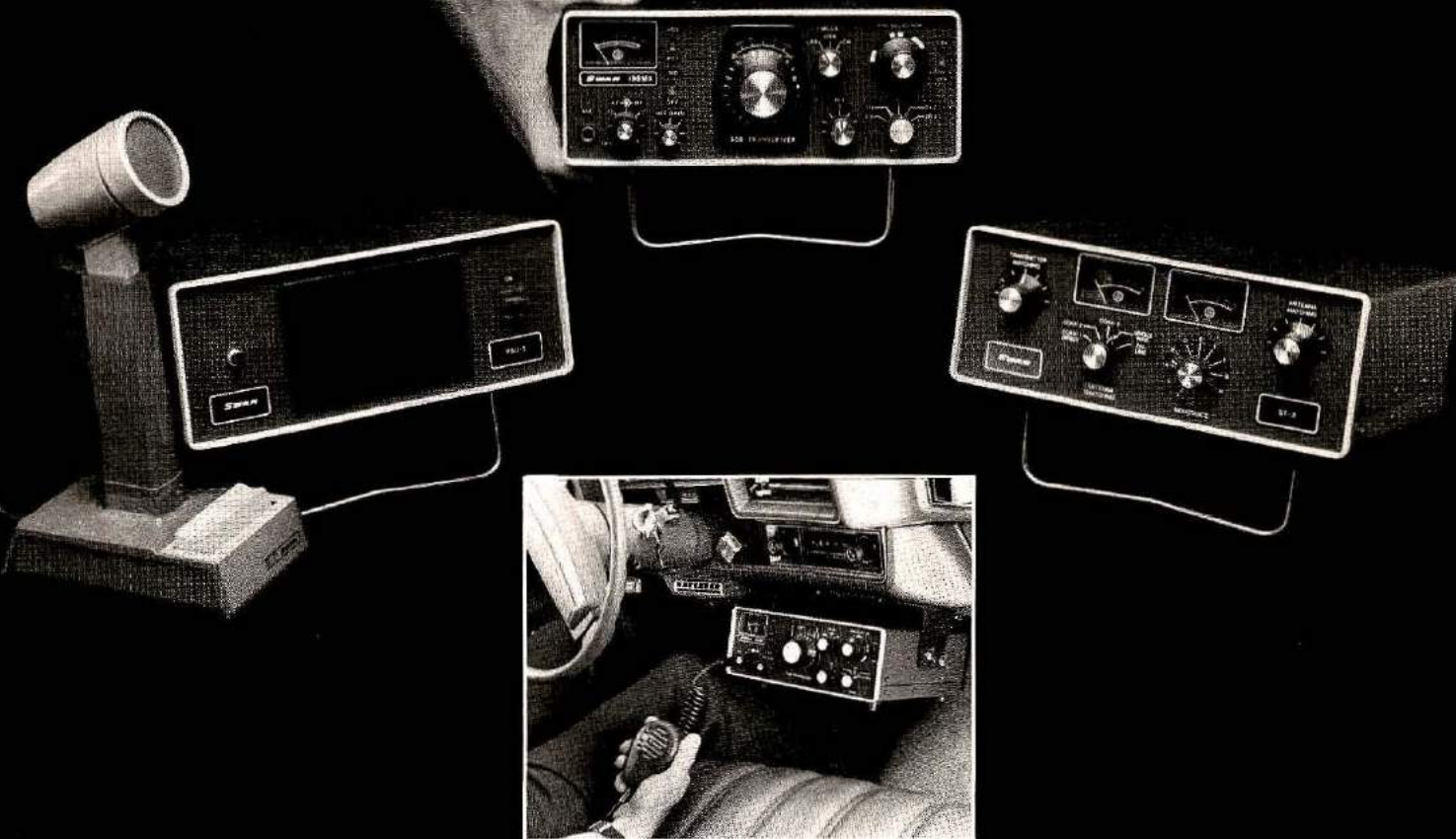

**The revolutionary Swan 100 MX: 100% new, 100% solid state,
100% portable from home station to mobile!**

Introducing a superb "get up and go" transceiver, superbly designed for 100% mobility and control, as only new Swan space-age technology could do it!

100% solid state 100 MX: the compact HF unit you can take seriously — anywhere you choose to operate.

At home, set into Swan's unique new style-coordinated station, with *matching* antenna tuner and power supply.

Or on the road — it's easy to relocate 100 MX. Instantly. Just two simple connections on the back panel: snap out, snap in... and run!

100% improved audio quality: home or mobile, transmit or receive. 100 MX electronics cut through SSB sound barriers —

producing a natural clarity reported comparable to AM!

Your most-wanted extras, 100% built-in: like noise blanker and VOX. Like a preselector to optimize signals. Like a real RF GAIN control, and CW sidetone.

Swan includes the RIT control (± 1.5 kHz) you'd like too. Plus, for stability, a permability tuned oscillator with 1Kc readout.

A powerful package, delivering a minimum 100 watts PEP output on all bands, 10-80 meters.

Setting a 100% new state of art: 100 MX and our matched-station units. Ready for check out today at your Swan dealer, the first major breakthrough in Swan's new program dedicated to changing the face — and performance — of ham equipment 100%...inside and out!

Swan 100 MX: \$849.95
Matching Power Supply PSU-5:
\$179.95
Matching Antenna Tuner ST-3:
\$169.95

Authorized Swan Dealer



**CW ELECTRONICS
SALES CO.**

1401 BLAKE ST., DENVER, CO. 80202
Phone (303) 893-5525

Swan's continuing commitment to product improvement may affect specifications and prices without notice.



Dear Horizons:

As one who is beginning his novice studies, I find a great deal of understandable material in *Ham Radio Horizons*, and I certainly will continue to be a subscriber. The magazine is great!

A question — I live in a condominium which does not allow any (noticeable) outside antennas, and the attic space is small: height is about 6 feet at the top and diagonal distance is about 30 feet.

What is the best type of multi-band antenna for me to use in this situation?

Some have suggested a random wire around and under the eaves of the house, used with a random wire tuner such as the SST Ultra Tuner. Others have suggested a "Slinky" type. Your answer will be much appreciated.

I suggest this problem (a common one for those who live in apartments) might be the subject for a future *Horizons* article.

E. E. Lumpkin
Santa Cruz, California

There's no way to predict what will be the "best" antenna for you, or anyone in similar living space. There are just too many variables. For instance, you could put a shortened dipole, with traps, in the attic space. It might or might not get out, as determined by how much wiring or other metals there is nearby to absorb and reflect the energy. This same wiring could very well conduct rf to other apartments, where the RFI would lead to irate neighbors. A Slinky is nothing more than another form of shortened dipole, and it has the same limitations that any short antennas do — namely, they're not as efficient as a full-sized antenna. There are a few basic

rules of thumb which you can rely on to make your own choice: a full-sized antenna will always work better than a shortened one, and, an outdoor antenna is better than an indoor one (less absorption of the signal), and, an antenna away from metallic objects works better than one near such objects. The closer to the ideal situation you can get, the better off you are, but that doesn't mean you shouldn't try something less than ideal. We have had several articles about short antennas for limited-space applications, and there will be more in the future. As you say, it is a popular subject for apartment dwellers. (Maybe someone should talk apartment builders into installing an all-band dipole with multiple coaxial feeds for Amateur Radio tenants — just as they do with master TV antennas and distribution.)

Editor

Dear Horizons:

May I please put in an enthusiastic good word for the Oak Hill Academy summer Amateur Radio session in Mouth of Wilson, Virginia. I just completed the two-week session and am quite proud of my new General Class license that resulted from it. The instruction is truly professional, the studying is intensive, and the Blue Ridge Mountains are exquisite. Anyone interested in working hard on any level from Novice to Extra should do what I did: look for the advertisement in *Ham Radio Horizons* next winter, and enjoy your hobby even more.

Herb Gross, WA1USE
Norwalk, Connecticut

Dear Horizons:

I am not much on writing letters, but because of what has recently happened I felt obligated to drop you a line. To begin with, I have been very disgusted lately because I was unable to upgrade my license. I'd assumed it would be all over for me when my Novice license runs out next month, because I didn't know I would be able to renew it. That, plus the fact that money has been scarce lately, caused me to let my subscription to *Ham Radio Horizons* run out. Then, you sent me that wonderful letter saying I could renew my Novice license, and even included

an application. Believe me, it was like a reprieve from a life sentence to C.B. radio. Ever since I first started getting your magazine I knew it was the best, but this really put the icing on the cake. Everyone knows that big outfits like yours just don't do things like this for us little guys, but you *did*, and I am not one for forgetting favors. Please find the enclosed check and sign me up for another year of *Ham Radio Horizons* and accept my heartfelt thanks. You can be sure I will be trying harder than ever to upgrade my license now, and become a real HAM. Thanks again to you.

Arthur L. Garland, WB3ONC
Bolivar, Pennsylvania

Dear Horizons:

I would like to thank you for helping me get my ticket. I always wanted to be a ham since I was 6 years old. Now I am 15. My science teacher, Mr. Fred Scielzo, WA2FKF, ordered *Ham Radio Horizons* for the school library. When I read it in December it sparked my interest again. I decided to give it one more shot and I made it!

I would like to thank Mr. Scielzo for his patience, for he was my "Elmer."

Bill Kantz, WD2AEL
Clifton, New Jersey

Dear Horizons:

I enjoyed the W6SAI story on the Sky Buddy receiver in the May, 1978, issue. My S-19R arrived on January 7, 1941, purchased from Montgomery Ward for \$5 down, \$5 per month. Five dollars bought a lot of groceries back then . . .

I sold the Sky Buddy in April, 1959 — during those 18 years my wife and I carted that receiver from Los Angeles to Wright Field, Schenectady, Hartford, Rock-springs, and San Antonio, Texas, San Diego, and Chino, California, and finally to Pomona. The Sky Buddy served as both broadcast and ham radio receiver. My wife never accepted the "ham-band-only" receiver I acquired to replace the old Sky Buddy. Noticing Bill Orr's story with its photographs, she asked, "Why did you sell it?" For just a moment she was misty eyed. Memories!

Don Hutchins, K6GOU
Pomona, California

YOU ASKED FOR IT YOU GOT IT DSI QUIK-KIT®

550 MHZ COUNTER KIT Performance You Can Count On



OPERATES ON

- Batt 6-C Size
- DC 8.2 To 14.5 VDC
- AC Batt. Eliminator

\$99.95
MODEL 3550 KIT

DSI OFFERS THE BEST OF TWO WORLDS . . .

An unprecedented DSI VALUE . . . in a high quality, LSI Design, 550 MHZ frequency counter kit. And, because it's a DSI innovation, you know it obsoletes any competitive makes, both in price & performance. The basic 550 MHZ counter & time base are factory assembled, tested and burned-in. The problems of bad LEDs, IC's, capacitors, are a thing of the past with DSI QUIK-KIT®. But you can take pride in assembling the power supply, PC mounted selector switch, input connectors, and the final mechanical assembly of your 550 MHZ counter, into its' handsome cabinet. **GO WITH THE LEADER . . . BUY A DSI FREQUENCY COUNTER KIT. SAVE TIME & MONEY AND BE ASSURED IT WILL WORK THE FIRST TIME.**

SPECIFICATIONS

Time Base TCXO 1PPM 65° to 85°F
Frequency Range 50HZ to 550MHZ
Resolution 1HZ to 55MHZ, 10HZ to 550MHZ
Gate Time 1 second - 1/10 second
Sensitivity 25MV 150 & 250MHZ 75MV 550MHZ
Display Eight 1/2-inch LEDs
Input Two SO239 Connectors
Power 6C-Size Batt., 15HR, or 8.2VDC to 14.5VDC
Current 150 Ma standby 300 Ma operational

3550 KIT INCLUDES

- Pre-assembled, tested counter board
- Case, power supply, connectors, hardware
- Built-in prescaler & preamp
- Gate Light - Automatic Zero Blanking
- Automatic Decimal Point
- One to two hours assembly time
- One Year Warranty on all parts
- All new parts - not factory seconds or surplus

3550 Kit	\$99.95
T-101 Telescopic Antenna	3.95
AC-9 Battery Eliminator	7.95
Cigarette Lighter DC Adapter	2.95

TERMS: Orders to U.S. and Canada, add 5% to maximum of \$10.00 per order for shipping, handling and insurance. To all other countries, add 15% of total order. California Residents add 6% State Sales Tax.

SEE YOUR LOCAL DEALER
OR

CALL TOLL FREE (800) 854-2049
California Residents, Call Collect (714) 565-8402

DSI INSTRUMENTS, INC.

7914 Ronson Road No. G, San Diego, CA 92111

VISA • MC
AMERICAN EXPRESS
CK • MONEY ORDER
COD

PRODUCT SHOWCASE

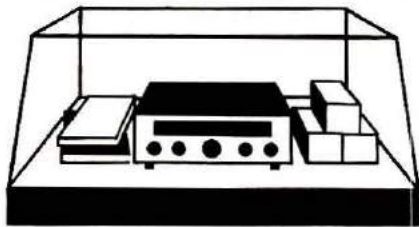

Drake R-7 receiver



The new Drake R-7 receiver is presently in the design and prototype stage with first shipments scheduled for early 1979. Preliminary specifications are listed in Table 1. The receiver is 100 per cent solid state, fully synthesized with a permeability tuned oscillator (PTO) for smooth tuning. It has continuous tuning from 0-30 MHz, and offers both a digital readout and an analog dial.

As with the Drake TR-7 transceiver, the R-7 receiver features

up-conversion to a first i-f at 48 MHz; a special high-level, double-balanced mixer provides a high intercept point and strong signal handling characteristics. The receiver uses a full set of bandpass "window filters" that operate from 30 MHz, through VLF, to zero MHz. This permits performance in the MF/LF/VLF range that is very similar to that in the high-frequency range. As a result, external VLF preselectors or converters are not required.

The bandswitch selects various groups of window filters and determines the frequency limits of each range. Any 500-kHz segment within these limits is selected by simply depressing the UP or DOWN pushbuttons until the desired segment is reached. Tuning within the segment is accomplished by the PTO, which is connected to the main tuning knob.

A 10-dB, pushbutton-selected preamp can be activated on all ranges above 1.5 MHz. This preamp improves the overall sensitivity from approximately 0.5 μV to approximately 0.2 μV . As with any rf amplifier, however, its use lowers the intercept point by approximately the same amount as its gain. Therefore, preamp use should be limited to

weak signal environments for best overall front-end performance.

The second i-f of the R-7 operates at 5645 kHz, and the selectable 8-pole crystal filters operate in this range. A choice of 300 Hz, 500 Hz, 1800 Hz, and 4.0 kHz filters are available, in addition to the 2.3-kHz ssb filter. Any of these filters may be selected from the front panel with a 5-position switch. It should be noted that the MODE switch operates independently of these filters, and can select either a special new synchro-phase a-m detector, or the product detector. Excellent international a-m shortwave and broadcast band reception can be realized with the low-distortion synchro-phase a-m detector.

The third i-f operates at 50-kHz and features a tunable i-f notch filter for heterodyne rejection. The notch depth is approximately 40 dB.

Extremely flexible selectivity combinations may be realized by the proper choice of an 8-pole crystal filter, notch adjustment, and positioning of the passband tuner, which is also employed in the R-7 receiver. The passband tuner is full range and enables the operator to properly set the passband position, in relation to

Table 1. Preliminary specifications for the new Drake R-7 communications receiver.

Frequency coverage	0-30 MHz with DR-7 digital readout general coverage board; 0.5-2.0, 2.5-3.0, 3.5-4.0, 4.5-5.0, 7.0-7.5, 14.0-14.5, 21.0-21.5, 28.5-29.0 MHz without Aux-7 (Aux-7 adds any eight 500-kHz segments from 0 to 30 MHz)	(preamp not operational below 1.5 MHz)
Frequency stability	Less than 100 Hz drift after warmup	
Readout stability	Analog dial: better than ± 1 kHz when calibrated to nearest marker Digital: 15 ppm \pm 100 Hz	
Sensitivity (500 kHz-30 MHz)	0.5 μV or less for 10 dB (S + N)/N on ssb and CW; 0.2 μV or less with preamp turned on; 2.0 μV or less for 10 dB (S + N)/N on a-m (30% modulation); 1.0 μV or less with preamp turned on;	(0-500 kHz) 2.0 μV or less for 10 dB (S + N)/N on ssb and CW; 1.0 μV or less for 10 dB (S + N)/N on a-m
		Selectivity Same as TR-7 (ultimate selectivity greater than 90 dB)
		Agc Same as TR-7
		Intermodulation Intercept point at +20 dBm minimum; two-tone dynamic range, 95 dB
		Image and i-f rejection Greater than 80 dB
		Audio output 2.5 watt with less than 10% THD into 4-ohm load
		Power supply 110/220 Vac 50/60 Hz or 11-16 Vdc
		Dimensions Same as TR-7

the selectivity filter, for any mode continuously from RTTY to CW or any sideband. Various positions of agc, from OFF to SLOW, are also available from the front panel.

The R-7 will transceive with the Drake TR-7, and these functions are pushbutton controlled. The R-7 also has a unique antenna switch/toroidal splitter so that both the R-7 and TR-7 may be used on the same antenna for simultaneous dual receive. This will be a boon to DXers who wish to monitor an out-of-band DXpedition, and the in-band pile-up at the same time. The antenna selector also permits alternate antennas to be used on the receiver and a main antenna on the transceiver, or vice versa. The alternate antenna may also be split between the two units.

The receiver features receiver incremental tuning (RIT), so that the receiver frequency may be varied independently of the transmit frequency when operated in transceive with the TR-7. As with the TR-7, the digital readout in the R-7 may be used as an external counter to 150 MHz.

The receiver's built-in power supply operates from either 12 Vdc or 120/240 Vac. The styling, color, and size of the R-7 matches that of the TR-7, and either the internal speaker or an external MS-7 speaker may be used. Further information and prices will be available from the R.L. Drake Co. by the end of 1978.

"Band-Aids" Handbook

James Dersch, WD0AJE, has just published *Band-Aids*, which he calls the "Radio Amateur Operator's Handiest Handbook." If you've ever had to frantically search for some bit of information in the midst of a QSO or contest, you will agree with that description.

Band-Aids is a spiral-bound booklet full of handy information in a multitude of categories. It contains many operating aids that the amateur will find useful

— or even essential — during the many activities he pursues. It has maps and lists for such things as the Worked All States award (WAS), time-zone information, abbreviations, IACO word list (phonetic alphabet), OSCAR frequencies, U.S. 160-meter allocations, W1AW broadcast schedule, third-party agreement information, amateur networks

listings and Q-signals, international prefix lists, and many other bits and pieces that are always needed at your fingertips but manage to get lost at the wrong time.

In the nonoperating category, *Band-Aids* contains useful material on metric conversions, resistor (and other component) color coding, schematic-dia-



target your signal with a Big Talk™

*the Engineered Choice for Antennas Up to 5.0 Square Feet.**

- 50 Ball Bearings — frictionless capacity
- Cast Aluminum Housing — weather protected
- 500 In. Lbs. Torque — superior turning capability
- Automatic Disc Brake — protects total system

The Big Talk Control

- Solid State — silent automatic operation
- 360° Target Selector — instant global selection
- 4 Target Preselector — program repeated contacts
- Low Voltage Operation — complete safety

Only Cornell-Dubilier could bring you the Big Talk by combining 30 years of rotor manufacturing know-how with advanced solid state technology. This All American product offers you pinpoint control of antenna systems from stacked two meter arrays to dual polarized eleven meter quads. Program your choice of four continents or four base stations with the exclusive Big Talk preselector. Choose CDE, the standard of the world, for better communications.

*When in-tower mounted, 2.5 sq. ft. free standing.

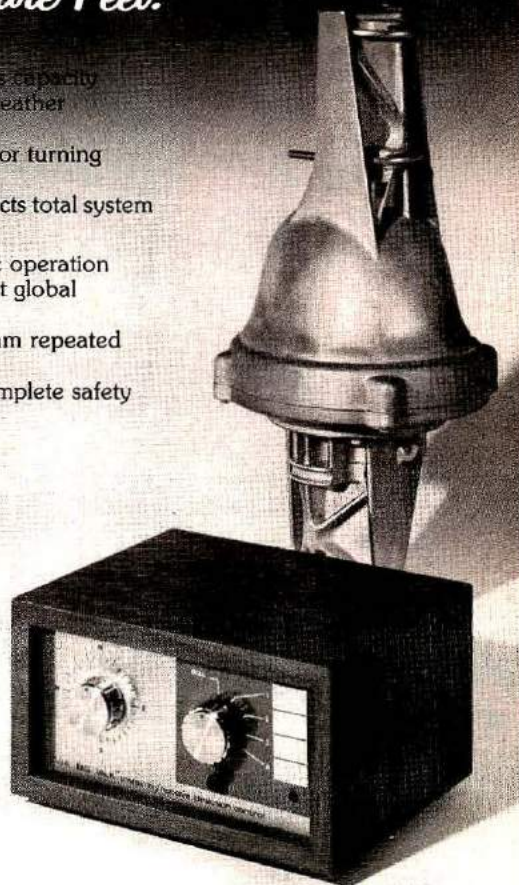

CORNELL-DUBILIER ELECTRIC CORPORATION
SUBSIDIARY OF FEDERAL PACIFIC ELECTRIC COMPANY
150 Avenue L, Newark, N.J. 07101/35 Mobile Dr., Toronto, Ontario, Canada M4A2P6

355

THE BEST



TOP OF THE LINE. NUMBER ONE. IF YOU'RE THE TYPE OF PERSON THAT WILL SETTLE FOR NOTHING LESS, WE'VE GOT WHAT YOU'RE LOOKING FOR. TOP OF THE LINE FROM THE THREE TOP LINES. AND WE OFFER MORE THAN JUST THE RIGS—SUPER SERVICE AFTER THE SALE. CALL US SOON FOR A QUOTE ON YOUR NEXT RIG.

ORDER TOLL FREE!
800-845-6183

G.I.S.M.O.
2305 CHERRY ROAD
ROCK HILL, S.C. 29730

gram symbols, telephone tone-control frequencies, vswr nomograph, some useful formulas, and much more.

Band-Aids contains 110 pages, and measures 14 x 21 cm (5-1/2 x 8-1/2 inches). The spiral binding allows it to lie flat, and the compact size allows it to fit comfortably on even the smallest of operating positions. You can obtain one from Ham Radio's Communications Bookstore, Greenville, New Hampshire 03048, for \$7.95, plus 40 cents shipping and handling. Order CC-BA.

Cover Craft Dust Covers

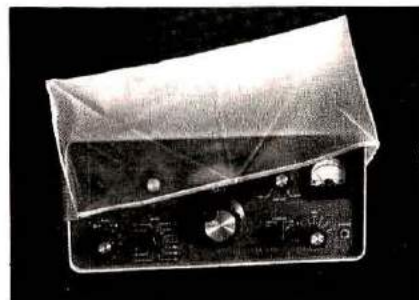

Nothing says more about how you value your equipment than its appearance — and that's a direct result of how you treat it. Most amateurs are reasonably careful while using their equipment, but when the switches are off the matter is forgotten. Dust from cleaning, cigarette ashes, spilled coffee, bits of wire or solder — all can find their way into your gear almost any time, so why not protect it by covering it up?

More than their protective value, Cover Craft dust covers enhance the resale value of equipment; cleaner rigs bring more as trade-in or flea-market items. Less maintenance is required on a clean rig, too.

Cover Craft covers are made of high-quality vinyl, with a special finish that lets the features of your equipment show through — you're not hiding your station when you protect it. Excellent construction is used; all edges and seams are machine-stitched

If you expect to invest in a new ham antenna in the next 90 days, invest 15¢ postage to get Antenna Specialists' brand new, complete ham catalog today.

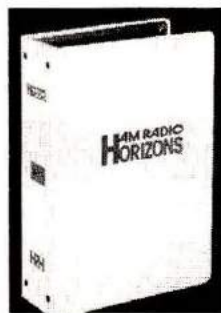
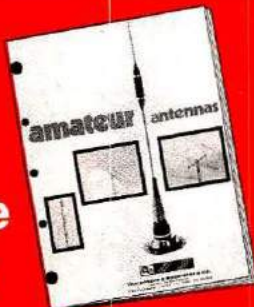

Bind 'em
and find 'em!

HORIZONS BINDERS

Don't let your valuable issues of Ham Radio HORIZONS get dog-eared or scattered who knows where! Get a handsome, durable binder from HRCB complete with date labels.

HR-HRDL . Each \$6.95
3 for \$17.95

To order, just send check, money order or credit card information to:
(include \$1.00 shipping)

HRCB
Greenville, NH 03048

Amateur Radio spoken here!

FREE decal just for fun!

Name _____
Address _____
City _____ State _____ Zip _____



the antenna specialists co.

a member of The Allen Group Inc.
12435 Euclid Ave. Cleveland, Ohio 44106
Export: 2200 Shames Drive, Westbury, L.I., New York 11590
Canada: A.C. Simmonds & Sons, Ltd.

for durability and professional appearance.

All Cover Craft covers are made to precisely fit most popular makes and models of equipment. Projections and special features are allowed for when the material is hand cut and sewn. Cutouts at the appropriate places make it easy to cover your rig without removing any cables.

You can obtain Cover Craft covers for many types of gear: tape decks, hi-fi systems, microprocessors, test equipment, CB base stations, and, of course, all popular makes of amateur receivers, transmitters, transceivers, amplifiers, and accessories. They'll even custom-fit a cover to your own design if you'll tell them size and shape.

Cover Craft dust covers — an investment in protecting your station. For prices and a list of equipment the covers will fit, write to Cover Craft, Post Office Box 555, Amherst, New Hampshire 03031; or use *ad check* on page 94.

500-watt RF Transformer

Palomar Engineers has a new broadband rf transformer. It matches vertical and mobile antennas to 50-ohm coaxial cable. Impedance values of 8, 12.5, 16, 22, 32, and 50-ohms can be selected by a convenient switch.

The transformer is mounted in a die-cast aluminum case 10 x 12 x 5 mm (4 x 5 x 2 inches) fitted with UHF (SO-239) connectors. The rf ferrite toroid core is wound with teflon-insulated wire and is rated at 500 watts in continuous commercial service. Operating frequency range is 1-30 MHz (1-10 MHz below 20 ohms).

Price is \$35 plus \$2 for shipping in the United States and Canada. For a free descriptive brochure write to Palomar Engineers, Post Office Box 455, Escondido, California 92025; or use *ad check* on page 94.

AMCOMM S 2 25 SYNTHESIZED TRANSCIVER

RECEIVER MODULE The receiver is of total solid-state design with all elements installed on Type G-10 commercial grade fiberglass PC boards. Sensitivity is 0.35uV minimum. Incorporates an 8 pole crystal filter with a 2 pole crystal discriminator operating at a single 21.4MHz IF. The design is further enhanced by the use of dual gate MOS FETs in the receiver front end.

HIGH QUALITY MICROPHONE Included with the S 2 25 is the top-of-the-line commercial grade microphone, made exclusively for AMCOMM by TURNER.

SYNTHESIZER The synthesizer is designed and built by AMCOMM using the latest state-of-the-art computer technology. It is the equivalent of over 1600 crystals delivering 800 channels with a choice of four (4) splits for each frequency.

TRANSMITTER Total solid-state design featuring continuously variable RF output power from 2 to 25 Watts. Delivers 16F3 emissions (+5KHz) with 100% modulation at 1000Hz Audio.



MADE IN
U.S.A.

"HAM" BUERGER, INC.

ELECTRONIC EQUIPMENT DISTRIBUTOR

68 N. YORK ROAD • WILL OW GROVE, PA. 19090 • (215) 659-5900

2 Miles South of PA Tpk Exit 27 on Rte. 611

"Servicing What We Sell Since 1956"



Mon., Wed., Fri. — 9:30-9:00

Tues., Thurs., Sat. — 9:30-5:30

WA3ZID-BOB • WB3BPJ-BOB • WB3GXP-DAVE • WB3HOF-JEFF



JOIN THE COSMIC QUEST!

• Subscribe now to **COSMIC SEARCH** and share the provocative articles and latest news about mankind's most exciting venture, the search for intelligent life in space. Get **COSMIC SEARCH** starting with its first issue, out December 1.

• **COSMIC SEARCH** is for everyone who has ever wondered about life in the universe.

• Featured in the first issues of **COSMIC SEARCH** are articles by RONALD BRACEWELL, JOCELYN BELL BURNELL, ARTHUR C. CLARKE, NORMAN COUSINS, FRANK D. DRAKE, CARL SAGAN, WALTER SULLIVAN and many other world-famous persons.

• Will communication be by radio, gravity waves or neutrino beams? Are there cosmic languages? Will long transmission times make us cosmic archeologists? These and many other questions are discussed in **COSMIC SEARCH** in a popular, authoritative manner.

• Exclusive interviews with noted researchers, book reviews and an extensive book list for further reading are regular special features of **COSMIC SEARCH**.

• **COSMIC SEARCH** award papers on SETI topics by students and others under 30 will add new talent.

• **COSMIC SEARCH** is published 6 times per year. First issue January 1979. Out Dec. 1, 1978.

COSMIC SEARCH, Radio Observatory, P.O. Box 293, Delaware, Ohio 43015 Tel. 614-363-1597

Single copies \$2.50 (\$15 a year). Subscription rate: \$12 for 1 year, \$22 for 2 years.

SPECIAL PRE-PUBLICATION rate \$10 for 1 year, \$18 for 2 years

SPECIAL PREPAID PRE-PUBLICATION rate \$8 for 1 year, \$15 for 2 years

Enter my subscription to **COSMIC SEARCH**, Box 293, Delaware, Ohio 43015
At special pre-publication rate: \$10 for 1 year \$18 for 2 years and bill me later.
At special PREPAID pre-publication rate: \$8 for 1 year \$15 for 2 years
 Check or Money Order enclosed MASTERCARD VISA (BankAmericard)

Account # _____ MC Interbank # _____ Exp. date _____

Name _____

Address _____

City _____ State _____ Zip _____

Yesterday you could admire LED digital tuning in short wave.* Today you can afford it.



Introducing Panasonic's Command Series™ top-of-the-line RF-4800. Everything you want in short wave. Except the price. Like a five-digit LED frequency display. It's so accurate (within 1 kHz, to be exact), you can tune in a station, even before it's broadcasting. And with the RF-4800's eight short wave bands, you can choose any broadcast between 1.6 and 31 MHz. That's the full frequency range. That's Panasonic.

And what you see on the outside is just a small part of what Panasonic gives you inside. There's a double superheterodyne system for enhanced reception stability and selectivity as well as image rejection. An input-tuned RF amplifier with a 3-ganged variable tuning capacitor for exceptional sensitivity and frequency linearity. Ladder-type ceramic filters to reduce frequency interference. And even an antenna trimmer that changes the front-end capacitance for maximum reception from minimal broadcast signals.

To help you control all that sophisticated

circuitry, Panasonic's RF-4800 gives you all these sophisticated controls. Like an all-gear-drive tuning control to prevent "backlash." Separate wide/narrow bandwidth selectors for optimum reception even in crowded conditions. Adjustable calibration for easy tuning to exact frequencies. A BFO pitch control. RF-gain control for increased selectivity in busy signal areas. An ANL switch. Even separate bass and treble controls.

And if all that short wave isn't enough. There's more. Like SSB (single sideband) amateur radio. All 40 CB channels. Ship to shore.



Even Morse communications. AC/DC operation. And with Panasonic's 4" full-range speaker, the big sound of AM and FM will really sound big.

The RF-4800. If you had a short wave receiver as good. You wouldn't still be reading. You'd be listening.

*The ability to receive short wave broadcasts will vary with antenna size, time of day, operator's geographic location and other factors. You may need an optional outside antenna to receive distant short wave broadcasts.

Panasonic
just slightly ahead of our time.

(Cut on dotted line and keep next to your radio equipment)

(Cut on dotted line and keep next to your radio equipment)

Call our toll-free number first

... and it's the last call you'll have to make!

(NO CHARGE TO CALLING PARTY)

1-800-325-3636

CALL FOR THE BEST PRICE AND FAST DELIVERY

ON THE FOLLOWING LINES:

ATLAS
COLLINS
DENTRON
DRAKE
HY GAIN

ICOM
INFO-TECH
KENWOOD
MOSLEY
STANDARD

SWAN
TEMPO
TEN-TEC
WILSON
YAESU

... AND MANY OTHERS.



HAM RADIO CENTER

8340-42 Olive Blvd. P.O. Box 28271 St. Louis, MO 63132



Gift and Save!

HAM RADIO HORIZONS

- Easy to give
- Fun to receive
- A reminder of your friendship all year long

Share your favorite hobby with special friends this holiday season and give Ham Radio HORIZONS. When you give two or more HORIZONS gift subscriptions, your savings are even greater.

Every month, for a full year, your friends will have fun reading all about Amateur Radio in Ham Radio HORIZONS — the exciting, colorful magazine designed originally for beginners, but now receiving rave reviews from experienced old-timers as well.

Make it easy on yourself by gifting HORIZONS this holiday season, and save!

\$10 First Gift
(save \$5.00*)

\$7.97 Each
Additional Gift
(save \$7.03*)

*Based on \$15.00 yearly newsstand price.

The Ham Radio Publishing Group Greenville, NH 03048

Yes! Please send my HORIZONS gift subscriptions as indicated. Also send a gift acknowledgement card.

Start or Renew my HORIZONS subscription.

\$ _____ is enclosed for _____ subscriptions.

Master Charge VISA/BankAmericard

Account

Expires MC Bank

Bill me after January 1, 1979.

FROM:

My Name _____ Call _____

Address _____

City _____ State _____ Zip _____

1st GIFT

Here's my first gift subscription for one year (12 issues) at \$10.00.

New subscription Renewal

SEND TO:

Name _____ Call _____

Address _____

City _____ State _____ Zip _____

2nd GIFT

Here's my second gift subscription for one year (12 issues) at just \$7.97.

New subscription Renewal

SEND TO:

Name _____ Call _____

Address _____

City _____ State _____ Zip _____

For additional gifts give complete information on separate sheet of paper and return with above order.

If it's for amateur radio, you know...

HARRISON HAS IT!

**KENWOOD
YAESU
CIR
SWAN
RL DRAKE**

**ICOM
COLLINS
TEMPO
ATLAS
TEN-TEC**

**PACE
WILSON
LARSEN
MOSLEY
KLM**

**CUSHCRAFT
NEWTRONICS
ROHN
HY-GAIN
WILSON**

**BIRD
NYE
B&W
AMECO
& MORE!**

HARRISON, HEADQUARTERS FOR



FT901DM

YAESU

FT901 DM	FC 901
HF Transceiver \$1459	Antenna Tuner \$199
SP901P	FV 901
Spkr/Phone Patch \$74	Synthesized VFO \$415



IC-280

ICOM

IC 280 Remote	IC 245/SSB
2 Meter Mobile \$445	All-Mode 2 mtr. Mobile \$599
IC 701 Synthesized	IC 215 2 Meter
HF Transceiver \$1495	Portable Transceiver \$249
IC 211 All-Mode	
2 Meter Transceiver \$749	

NEW! Synthesized FM two meter mobile by PACE



The all-new Communicator II fully synthesized, 25 watt 2-meter mobile. Write or call for our Introductory Price!

**SEND ME THE NEW 1979
HARRISON COMMUNICATIONS
CATALOG!**

CALL _____
NAME _____
ADR. _____
CITY _____
STATE _____ ZIP _____

HRH

CALL US!! IT'S TOLL FREE 1-800-645-9187

Harrison
radio
OUR 53rd YEAR

MAIL ORDERS:
20 Smith Street
Farmingdale, N.Y. 11735

PHONE 800-645-9187
ORDERS: 516-293-7990
212-895-4777

"Ham Headquarters U.S.A.®"

RETAIL SHOWROOM LOCATIONS

NEW YORK STATE

Farmingdale
2265 Route 110 11735 (516) 293-7990
New York City
301 Madison Ave. 10017 (212) 697-8910
Valley Stream
10 Sunrise Hwy. 11580 (516) 872-9565
Carle Place
181 Old Country Road 11514 (516) 746-6792
Oceanside
153 Long Beach Rd. 11572 (516) 764-4484

GEORGIA

Columbus 2313 Manchester Exp 31904
(404) 324-4185
Atlanta 4310 Roswell Road 30305
(404) 252-7209

RHODE ISLAND

Cranston 589 Reservoir Ave. 02920
(401) 467-3181



GREAT LAKES AMATEUR SUPPLY COMPANY

Friends and Fellow Hams:

Did you notice the new name? Well, I assure you that nothing has changed *except* the name! On September 1st Great Lakes Amateur Supply Company acquired the Amateur Radio Division of EDI — *and*, the same friendly service and prompt attention that you received for the past 39 years at EDI are *still* yours at Great Lakes. I personally want to welcome all my old customers, plus a flock of new ones, to do business with Great Lakes. I carry all the major lines, so call — or write — *now* to let me know your radio equipment needs. It will be good to hear from you.

73

Tom Reed, WA8URR, Proprietor

3993 LORENSON ROAD • MUSKEGON, MI 49445 • (616) 766-3868

Attention HAMS LOOKING for a great tower?

Do not attempt to raise antenna or antenna support near power lines—
YOU CAN BE KILLED!



Three good reasons to use Universal Towers

- 1. LIGHT WEIGHT**—In addition to its weight advantages, aluminum offers maintenance-free lifetime beauty. Eliminates painting and ugly rust inherent in steel towers.
- 2. EASY ASSEMBLY**—Child's play to assemble. You can easily put together a tower on the ground and walk it up, or assemble it erect section by section.
- 3. STRENGTH**—Important to your choice of a tower. Universal Towers are tested to withstand the force of 80 m.p.h. winds and are designed to resist winds exceeding that velocity.

In addition to all of these advantages, the total cost of a Universal Aluminum Tower is less than that of similar steel towers extended over the life of the tower.

If you have any questions regarding our product line, please contact your local distributor or call or write for information.

UNIVERSAL TOWERS

Universal Manufacturing Co. 12357 E. 8 Mile Rd. Warren, Mich. 48089 [313] 774-4140

FREE STANDING ALUMINUM TOWER



There's nothing like it !

RADIO AMATEUR
callbook

*Respected worldwide as
the only complete authority
for radio amateur
QSL and QTH information.*

The **U.S. Callbook** has over 300,000 W & K listings. It lists calls, license classes, names and addresses plus the many valuable back-up charts and references you come to expect from the **Callbook**.

Specialize in DX? Then you're looking for the **Foreign Callbook** with almost 300,000 calls, names and addresses of amateurs outside of the USA.

U.S. Callbook \$14.95

Foreign Callbook \$13.95

Order from your favorite electronics dealer or direct from the publisher. All direct orders add \$1.50 for shipping. Illinois residents add 5% Sales Tax.

RADIO AMATEUR
callbook INC.
Dept. E 925 Sherwood Drive
Lake Bluff, Ill. 60044

CALL TOLL FREE

1-800-438-2006

BOB'S AMATEUR RADIO CENTER

ALPHA • DRAKE
TEN-TEC • ICOM

DENTRON • TEMPO
SWAN • AMCOMM

BIRD • CUSHCRAFT
CONSOLIDATED TOWERS

TELEX • CDE Rotors

HY-GAIN • SHURE

HUSTLER • B&W

AMECO • BERK-TEC

MIDLAND • KLM

**We Stock
What
We
Advertise**

Taylor Antennas

**Microwave Filter
W2UA Baluns**

**Harris Mallow
World Clocks**



MLA-2500



TEN-TEC 544



CENTURY 21

Call Today

For YOUR Special Price

the indispensable

BIRD 43

THRULINE
WATTMETER

And Elements Shipped
Anywhere in the USA



UPS Delivery

Anywhere In USA

318 N. MAIN ST., SALISBURY, N. C. 28144

NORTH CAROLINA RESIDENTS
Call 1-636-7959

MONDAY — SATURDAY 9 A.M. - 7 P.M.
WEDNESDAY 9 A.M. - 9 P.M.



CD44
HAM III
TAILTWISTER

FOR THE HAM

A BELT BUCKLE



From The COLORADO SILVER CO

Cast In **SOLID BRONZE**

ENGRAVED WITH CARE

This fine personalized belt buckle can be yours for only \$12.50, plus \$1.00 for postage and handling.



APPROXIMATE SIZE
OF BUCKLE 2 1/4" x 3 1/4"

COLORADO SILVER CO

P. O. BOX 1755

ASPEN, COLO. 81611

COLO. RES. INCLUDE 3% SALES TAX

DRAKE OWNERS

Please note that our Las Vegas Repair facility is being closed in early September to allow staff personnel to return to our main plant in Ohio to help meet the fantastic demand for the TR-7 and other exciting new Drake products.

The need for a western factory service center has been reduced in recent months as our western dealers have expanded their service capabilities.

R. L. Drake Co.

540 Richard Street
Miamisburg, Ohio 45342
Phone 513-866-2421
Telex 288-017

ALDA 103

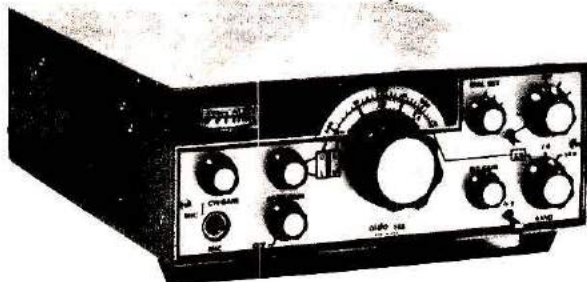

***SMALL IN SIZE**
***BIG IN FEATURES**

PERFORMANCE SPECIFICATIONS

Frequency Range: 80 meter band — 3.5 to 4.0 MHz
40 meter band — 7.0 to 7.5 MHz
20 meter band — 14.0 to 14.5 MHz

Modes: CW, USB, LSB

RF Input Power: SSB — 250 watts PEP nominal
CW — 250 watts DC maximum (adjustable)

Transmitter:

Antenna Impedance: 50 ohm, unbalanced

Carrier Suppression: Better than 45 dB

Side-Band Suppression: Better than 55 dB at 1000 Hz

Receiver:

Sensitivity: Better than 0.5 watts audio output for 0.5 μ V input

Signal-to-Noise Ratio: Better than 10 dB S+N/N for 0.5 μ V input

Image Ratio: Better than -60 dB (typical with respect to 0.5 μ V input: 80 meters — -130 dB; 40 meters — -100 dB; 20 meters — -75 dB).

IF Rejection: Better than -70 dB (typical with respect to 0.5 μ V input: 80 meters — 110 dB; 40 meters — 80 dB; 20 meters — 75 dB)

Intermodulation

Intercept Point: Better than 10 dBm

Selectivity: 2.5 kHz — 6 dB; 5.0 kHz — 60 dB

Audio Output Power: More than 3 watts

ORDER TOLL FREE!

800-845-6183



G.I.S.M.O.

2305 CHERRY ROAD
ROCK HILL, S.C. 29730

DON'T KEEP A GOOD ANTENNA DOWN

... put it up instead. Install the World-Record Breaking antenna that won W6TYP the QRP ARC 1,000,000 miles/watt award.

THE JOYSTICK VFA

(Variable freq. ant) gives low angle, omnidirectional, harmonic free radiation on all bands 160 thru 10 (+ MARS and receive on all BC & SW).

1000's of glowing reports in our files of the VFA in use, often in poor QTH and/or under QRP, contests, etc..

SYSTEM 'A' \$84.00

250W P.E.P. &/or Receiving only

SYSTEM 'J' \$110.00

500W P.E.P. &/or Improved Q Factor Receive

Air mail cost included (Each system 3 sections easily assembled to make unit 7' 6" long. Matching ATU). Not only will you save space but you get better value per \$ if buying direct UK manuf. Rush your order — Mastercharge, Visa, Bankamericard, or check, or ask for brochure:-

**PARTRIDGE (HH)
ELECTRONICS LTD.**

Broadstairs, Kent, England
Tel: 0843 62535

G3CED

G3VFA



YAESU
The radio.



FT-901 DM Competition Grade

Is Our Number **1** Line At

Cohoon Amateur Supply

TO SERVE YOU BETTER **3 LOCATIONS**



FT-301D

Cohoon Amateur Supply

SOUTH

Hwy. 475 Trenton, Kentucky 42286

502-886-4534



FT-101E

Cohoon Amateur Supply

NORTH

Box 4073 Austintown, Ohio 44515

216-538-3424



FT-7

Cohoon Amateur Supply

WEST COAST OUTLET

728 Juniper Lompoc VAFB, CA. 93437

805-734-4693

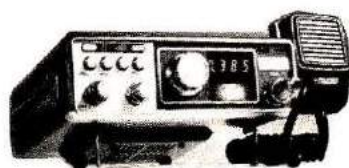

FT-227R

1. Full Repair Service
 2. Sub-Dealers Welcome
 3. Good Prices
 4. Ship UPS The Same Day
 5. All Used Gear
- Has A 90 Day Warranty.

Also Stocking:

KENWOOD	KANTRONICS
TEN-TEC	ATLAS
TEMPOC	DENTRON
WILSON	CUSHCRAFT
INFO-TECH	

Write for used equipment sheets and dealer inquiries.



Call for the famous **HAM·KEY***

JUST DIAL

*TM Trade-Mark

1-800-325-3636

TOLL FREE



Model **HK-1**

- Dual-lever squeeze paddle
- Use with HK-5A or any electronic keyer
- Heavy base with non-slip rubber feet
- Paddles reversible for wide- or close-finger spacing

\$29⁹⁵



Model **HK-2**

- Same as HK-1, less base for incorporation in own keyer

\$19⁹⁵



Model **HK-3**

- Deluxe straight key
- Heavy base...no need to attach to desk
- With navy type knob

\$16⁹⁵

Model **HK-3A**

- Same as above less base **\$9.95** Extra: navy type knob only **\$2.75**

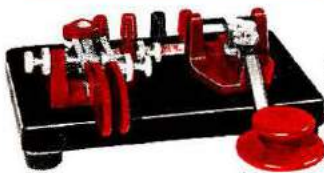

Model **HK-4**

- Combination of HK-1 and HK-3 on same base **\$44⁹⁵**
- Base only with rubber feet **\$12.00**
- Terminals, red or black. **\$.75 each**



Model **HK-5A** Electric Keyer

- New Cabinet Colored-Keyed to Match most modern radio equipment
- Iambic Circuit for squeeze keying
- Self-completing dots and dashes
 - Curtis 8044 I.C. Keyer Chip
 - Battery operated with provision for external power
 - Built-in side-tone monitor
 - Grid block or direct keying

\$69⁹⁵

Same day shipment...PREPAID
So order today direct or from your favorite dealer

HAM RADIO CENTER

8340-42 Olive Blvd • P.O. Box 28271 • St. Louis, MO 63132



Tune in your ears to our **Novice Study Cassette.**

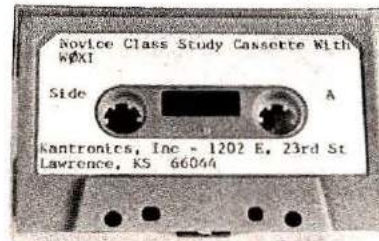

only
\$4.95

Kantronics Novice Study Cassette

Some people just don't have time to enroll in a ham radio class!

Think of the times you can't be in a class, or be reading a Novice theory manual, **that you could be listening to someone discuss the basics of ham radio.**

The **Kantronics Novice Class Study Cassette** lets you take the instructor along, whether it's to the breakfast table, in the car or at work during breaks! WØXI, an Extra class ham operator, discusses the "Novice ticket" and touches on all parts of the FCC requirements for passing examination.

Visit your Kantronics dealer today, or write us below!

KANTRONICS

The Lightweight Champs.

1202 East 23rd Street
Lawrence, Kansas 66044
We accept Visa, Master Charge, check, and money orders. Phone 913 642 7345

Keep your rigs newer, longer with Cover Craft **Dust Covers**



- Protects your equipment and your investment
- Handsome appearance precise fit
- Made of durable vinyl — machine stitched

Cover Craft Dust Covers are custom designed for hundreds of different models.

If you've invested hard earned cash in ham gear, you want it to last long and bring a good trade-in price. Our covers can help. They reduce dust build-up on surfaces and vital components which can degrade performance and destroy value. Repairs are reduced, useful life is extended. You save!

See your dealer or send S.A.S.E. for list of over 100 covers and complete order information.



COVER CRAFT

P.O. BOX 555, AMHERST, NH 03031

Telephone (603) 673-8592

You're just a few digits away from name brand radio equipment - AT DISCOUNT PRICES!

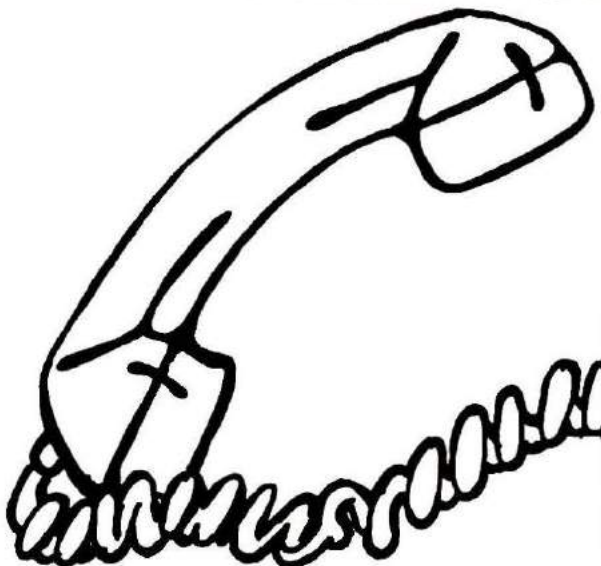

CALL TOLL FREE

1-800-228-4097
Communications Center

443 N 48th Street
Lincoln, Nebraska 68504
In Nebraska Call (402)466-8402

1-800-634-6227
**Communications Center
West**

1072 N. Rancho Drive
Las Vegas, Nevada 89106
In Nevada Call (702)647-3114

YAESU
KENWOOD
DRAKE
ICOM
STANDARD
EDGE COM
KDK

DENTRON
HY-GAIN
MOSLEY
CUSHCRAFT
WILSON
HUSTLER
LARSEN

TAYLOR
SWAN
TEMPO
TEN-TEC
MIDLAND
CDE
AUTEK

E.T.O. ALPHA
VHF ENGINEERING
BERK-TEK CABLE
CONSOLIDATED TOWER
SAY
SHURE
TELEX

plus many more

1-800-228-4097

CALL TOLL FREE FOR

1-800-634-6227

ANTENNAS

HY-GAIN
TH6 DXX
TH3MK III
18 AVT/WB

MOSLEY
CLASSIC 33
CLASSIC 36
TA-33

CUSHCRAFT
ATB-34
ARX-2
A-147-20T

HUSTLER
4BTV
66-144A
RM-75s

WILSON
SYSTEM 1
SYSTEM 2

Specials on CDE Rotors

Ham III - \$125.00
Taitwister - \$225.00

■ ■ ■ ■ ■ LOOK! ■ ■ ■ ■ ■

HOURS: Monday - Friday 8 a.m. - Midnight
Saturday 8 a.m. - 8 p.m.
Sunday Noon - 8 p.m.

SAME DAY SHIPPING ON MOST ITEMS

**We carry all major lines of antennas
at DISCOUNT PRICES
call for quotes: 1-800-228-4097**



HRH LOCATOR

TO HELP YOU FIND YOUR LOCAL AMATEUR RADIO DEALER

Alabama

LONG'S ELECTRONICS
2808 7TH AVENUE SOUTH
BIRMINGHAM, AL 35202
800-633-3410
Call Us Toll-Free
To Place Your Order.

Arizona

POWER COMMUNICATIONS
6012 N. 27 AVENUE
PHOENIX, AZ 85017
602-242-6030
Arizona's #1 "Ham" Store,
Kenwood, Drake, Icom & more.

California

C & A ELECTRONIC ENTERPRISES
22010 S. WILMINGTON AVE.
SUITE 105
P. O. BOX 5232
CARSON, CA 90745
213-834-5868
Not the biggest, but the best —
since 1962.

TOWER ELECTRONICS CORP.
24001 ALICIA PARKWAY
MISSION VIEJO, CA 92675
714-768-8900
Authorized Yaesu Sales & Service.
Mail Orders A Specialty.

Connecticut

AUDIOTRONICS, INC.
18 ISAAC STREET
NORWALK, CT 06850
203-838-4877
The northeast's fastest growing ham
department. Dedicated to service.
Kenwood dealer.

Delaware

**AMATEUR AND ADVANCED
COMMUNICATIONS**
3208 CONCORD PIKE (RT. 202)
WILMINGTON, DE 19803
302-478-2757
Delaware's Fastest Growing
Ham Dealer.

Florida

AGL ELECTRONICS, INC.
1800-B DREW STREET
CLEARWATER, FL 33515
813-461-HAMS
West Coast's Only Full Service
Amateur Radio Store

AMATEUR RADIO CENTER, INC.
2805 N.E. 2ND AVENUE
MIAMI, FL 33137
305-573-8383
The Place For Great Dependable
Names in Ham Radio

**LAFAYETTE RADIO ELECTRONICS
(Assoc. Store)**
1811 N. HIGHWAY 17-92
MAITLAND, FL 32751
305-831-2271
The Electronics Emporium

RAY'S AMATEUR RADIO
1590 US HWY. 19 SOUTH
CLEARWATER, FL 33516
813-535-1416
West Coast's only dealer: Drake,
ICOM, Cushcraft, Hustler.

Illinois

AUREUS ELECTRONICS INC.
1415 N. EAGLE STREET
NAPERVILLE, IL 60540
312-420-8629
"Amateur Excellence"

ERICKSON COMMUNICATIONS, INC.
5935 NORTH MILWAUKEE AVE.
CHICAGO, IL 60646
312-631-5181
Hours 9:30-5:30 Mon., Tues., Wed.,
Fri.; 9:30-9:00 Thurs.; 9:00-3:00 Sat.

KLAUS RADIO, INC.
8400 NO. PIONEER PARKWAY
PEORIA, IL 61614
309-691-4840
Let Us Quote Your Amateur Needs.

SPECTRONICS, INC.
1009 GARFIELD STREET
OAK PARK, IL 60304
312-848-6777
Chicagoland's Amateur Radio
leader.

Indiana

HOOSIER ELECTRONICS, INC.
P. O. BOX 2001
(43B Meadows Shopping Center)
TERRE HAUTE, IN 47802
812-238-1456
Communications Headquarters
of the U.S.A.

Iowa

BOB SMITH ELECTRONICS
RFD #3, HIGHWAY 169 & 7
FORT DODGE, IA 50501
515-576-3886
For an EZ Deal on New
or Used Equipment.

Kansas

ASSOCIATED RADIO
8012 CONSER, P. O. B. 4327
OVERLAND PARK, KS 66204
913-381-5901
Amateur Radio's top dealer.
Buy — Sell — Trade.

Maryland

THE COMM CENTER, INC.
LAUREL PLAZA - RTE. 198
LAUREL, MD 20810
301-792-0600
R. L. Drake, Ten-Tec, Icom, Wilson,
Tempo, DenTron, Mosley, Cushcraft.

Massachusetts

TEL-COM, INC.
675 GREAT RD., RT. 119
LITTLETON, MA 01460
617-486-3040
The Ham Store of New England
You Can Rely On.

TUFTS ELECTRONICS
209 MYSTIC AVENUE
MEDFORD, MA 02155
617-395-8280
New England's Friendliest
Ham Store.

Continued

Michigan

ELECTRONIC DISTRIBUTORS
1960 PECK STREET
MUSKEGON, MI 49441
616-726-3196
Dealer for all major amateur
radio product lines.

RSE HAM SHACK
1207 W. 14 MILE
CLAWSON, MI 48017
313-435-5660
Complete Amateur Supplies.

Minnesota

PAL ELECTRONICS INC.
3452 FREMONT AVE. NO.
MINNEAPOLIS, MN 55412
612-521-4662
The Midwest's fastest growing
ham dealer.

Nebraska

COMMUNICATIONS CENTER, INC.
443 N. 48 STREET
LINCOLN, NE 68504
800-228-4097
Kenwood, Yaesu, Drake and More
at Discount Prices.

New Hampshire

EVANS RADIO, INC.
BOX 893, RT. 3A BOW JUNCTION
CONCORD, NH 03301
603-224-9961
Icom, DenTron, Yaesu, Drake.
We service what we sell.

New Jersey

ATKINSON & SMITH, INC.
17 LEWIS STREET
EATONTOWN, NJ 07724
201-542-2447
Ham supplies since "55".

METUCHEN RADIO
216 MAIN STREET
METUCHEN, NJ 08840
201-494-8350
New and Used Ham Equipment.
WA2AET "T" Bruno

RADIOS UNLIMITED
1760 EASTON AVENUE
SOMERSET, NJ 08873
201-469-4599
New Jersey's newest, complete,
Amateur Radio center.

New York

ADIRONDACK RADIO SUPPLY, INC.
185 WEST MAIN STREET
AMSTERDAM, NY 12010
518-842-8350
Yaesu and Kenwood dealer
for the Northeast.

HAM-BONE RADIO
(Div. Stereo Repair Shop)
3206 ERIE BOULEVARD, EAST
SYRACUSE, NY 13214
315-446-2266
We Deal, We Trade,
We Discount, We Please!

HARRISON RADIO CORP.
20 SMITH STREET
FARMINGDALE, NY 11735
516-293-7990
"Ham Headquarters USA®"
since 1925.
Call toll free 800-645-9187.

RADIO WORLD
ONEIDA COUNTY AIRPORT
TERMINAL BLDG.
ORISKANY, NY 13424
315-337-2622
New & Used Ham Equipment. See
Warren K2IXN or Bob WA2MSH

Ohio

**AMATEUR RADIO
SALES & SERVICE INC.**
2187 E. LIVINGSTON AVE.
COLUMBUS, OH 43209
614-236-1625
Antennas for all services.

UNIVERSAL AMATEUR RADIO
1280 AIDA DRIVE
REYNOLDSBURG (Columbus)
OH 43068
614-866-HAMS
Drake, Yaesu, Ten-Tec, KDK, Wilson.
All Lines In Stock.

Pennsylvania

ARTCO ELECTRONICS
302 WYOMING AVENUE
KINGSTON, PA 18704
717-288-8585
The largest variety of semiconduc-
tors in Northeastern Pennsylvania

ELECTRONIC EXCHANGE
136 N. MAIN STREET
SOUDERTON, PA 18964
215-723-1200
Demonstrations, Sales, Service.
New/Used Amateur Radio Equip.

**HAMTRONICS, DIV. OF
TREVOSE ELECT.**
4033 BROWNSVILLE RD.
TREVOSE, PA 19047
215-357-1400
Same Location for
More Than 30 Years.

Texas

HARDIN ELECTRONICS
5635 EAST ROSEDALE
FORT WORTH, TX 76112
817-461-9761
You Bet Fort Worth
Has A Ham Store!

Dealers:

You should be
here too! Contact
HORIZONS today
for complete details.

TOLL
FREE **800-258-5353**

WE KNOW YOU WANT THE VERY BEST!

In a market already over crowded by others, all making claim to being "THE BEST", we knew we had to be better. *COMMUNICATOR I our 6 channel, 3 watt handheld, and COMMUNICATOR II our 800 channel synthesized 25 watt mobile offer all the

features of the "BEST" — and a few extra, including our one year warranty and a toll free 800 number answered by other hams who speak your language.

PACE COMMUNICATOR — THE VERY BEST!



pace COMMUNICATOR

AMATEUR PRODUCTS GROUP PATHCOM INC. 24105 SOUTH FRAMPTON • HARBOR CITY, CA 90710

* Communicator I will be available in the fall. Communicator II is in stock for immediate shipment.

ZZZ ELECTRONICS, INC.



We Sell & Service
These Lines
Call Now For HAM Prices

ICOM
KLM
DenTron
SWAN
KDK 2015R
Ten-Tec
Wilson
Telex
Hustler
Mosley
Cushcraft

Ameco
SAY Power Supplies
B&W Switches
Shore
Integrated Electronics
LARSEN
ADI Audio Dialers
PanaVise
Amphenol
Aluma Towers
And Many More

Special Prices On These Items Now

ICOM 211
KDK 2015R
Ten-Tec 570
Ten-Tec 574
DenTron All Band Doublet
SWAN TB4HA
SWAN TB3HA
DenTron MT2000A
DenTron MT3000A

ICOM IC215
KLM 144-148-16
KLM 144-148-14
KLM 144-148-50
RG8U COAX
DenTron Big Dummy
DenTron Jr. Monitor
YAESU FT101EE
ICOM 245SSB
SAY Elect. Power Supplies
KLM 2-25B
10' & 15' Roof Top Tripods

We accept
MC & Visa & Interbank Cards
— will ship UPS C.O.D.
422 ARMOUR CIRCLE N.E
ATLANTA GA 30324
(404) 876-0631

Come by or call William/WA4SVY



NEW VISUAL CODE READER AND ELECTRONIC KEYS

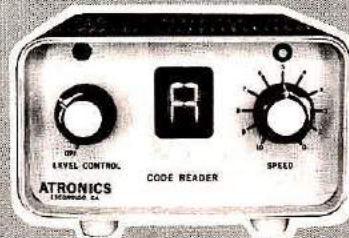

Works with any
keyer, including
squeeze keyer in
speeds from 7
WPM to 40
WPM. Both in a
single unit.
Model CR101EK
\$249

from ATRONICS

- Display letters, numbers, and commonly used punctuation visually as Morse Code signal is received.
- Operating speed 5 to 50 WPM at selected speeds.
- All Solid State
- Makes code learning faster and easier.
- A single connection to your receiver or transceiver speaker puts it into operation.
- Hard copy read-out of CW available with TU-102 TTY interface Module, accessory.

Our popular, lowest priced CODE READER KIT

Model KCR101 \$149
Ready made CODE READER . . . Model CR101 . . . \$225

BUY FACTORY DIRECT & SAVE! SEND FOR FREE LITERATURE.
USE YOUR BANKAMERICARD OR MASTER CHARGE

BOX 2946

LAGUNA HILLS, CA 92653

(714) 830-6428

Atronic

A fabulous new transceiver
from Swan...and it's available
from Henry Radio



SWAN 100 MX

**100% SOLID STATE
100% PORTABLE**

Introducing a superb "get up and go" HF transceiver, superbly designed for 100% mobility and control, as only Swan space-age technology could do it!

100% solid state 100 MX: the compact HF unit you can take seriously — anywhere you choose to operate.

At home, set into Swan's unique new style-coordinated station, with matching antenna tuner and power supply.

Or on the road — it's easy to relocate the 100 MX. Instantly. Just two connections on the back panel: snap out, snap in.

100% improved audio quality: home or mobile, transmit or receive. 100 MX electronics cut through SSB sound barriers — producing a natural clarity reported comparable to AM!

Your most-wanted extras, 100% built-in: like noise blanker and VOX. Like a preselector to optimize signals, an RF GAIN

control, and CW sidetone.

Swan includes the RIT control (± 1.5 kHz) you'd like too. Plus, for stability, a permability tuned oscillator with 1Kc readout.

A powerful package, delivering a minimum 100 watts PEP output on all bands, 10-80 meters.

Setting a 100% new state of art: 100 MX and our matched-station units. Ready for check out today at Henry Radio, the first major breakthrough in Swan's new program dedicated to changing the face — and performance — of ham equipment 100% inside and out!

Special Introductory Price: \$ 779.95

Matching Power Supply PSU-5: \$179.95

Matching Antenna Tuner ST-3: \$169.95

THE BEST PLACE TO BUY THE BEST EQUIPMENT...HENRY RADIO

And if you can't come into one of Henry Radio's stores, please call or write. Let us answer your questions and then ship one of these exciting new rigs to you. Henry Radio offers the most complete selection of famous name amateur radio equipment, plus easy financing. 10% down or trade-in down, no finance charge if paid in 90 days. Good reconditioned equipment, nearly all makes & models. Our reconditioned equipment carries a 15 day trial, 90 day warranty and may be traded back within 90 days for full credit toward the purchase of NEW equipment. Write for bulletin. Export inquiries invited.

11240 W. Olympic Blvd., Los Angeles, Calif. 90064 213/477-6701
931 N. Euclid, Anaheim, Calif. 92801 714/772-9200
Butler, Missouri 64730 816/679-3127

Henry Radio

Prices subject to change without notice

**MADISON
ELECTRONICS SUPPLY, INC.**

1508-C MCKINNEY
713/658-0268

HOUSTON, TEXAS 77002
Nites 713/497-5683

BELDEN

BIRD LOVERS

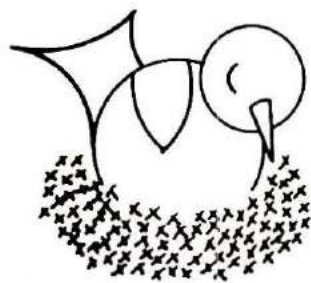

**FEATHER YOUR
OWN NEST . . .**

with a
MODEL
43



\$125

ALL ITEMS AND ELEMENTS
ORDINARILY IN STOCK

Prepaid Shipment in Continental USA Only

riw PRODUCTS

BOX 191, BABYLON, N.Y. 11702

**432 Yagis by
K2RIW**

- 1st Place - East Coast VHF Society's 1977 Antenna Gain Contest
- 19 Elements, *Tandem-Reflector**
- 12-MHz Bandwidth, 432-MHz CF
- Integral Balun, 50 ohm Type N
- All Elements Insulated from Boom - No gain loss from weathering!
- 13-ft Self-Supporting Boom
- Weighs only 2¾ pounds!

*Patent Pending

MODEL 432-19 . . . \$59.95

441 MHz CF ATV Model 441-19 . . . \$59.95

**CALL FOR FAST QUOTES
SPECIAL ORDERS WELCOME**

TERMS: All prices FOB Houston. Prices subject to change without notice. All items Guaranteed. Some items subject to prior sale. Send letterhead for Amateur dealers price list. Texas residents add 6% tax. Please add postage estimate.

W5GJ, W5MBB, K5AAD, N5JJ, W5IMJ, WD5DWL, WD5GDE, K5ZD, WD5ABR, WA5TGU, WD5BDX, WB5AYF, K5RC, K5BGB.

Have A Nice Day!
DLA.

Palomar Engineers

NEW ALL BAND PREAMPLIFIER

- Continuously Tuneable
- Covers All Amateur Bands from 160-6 m.
- Provides 20 db of gain
- Dual Gate FET for low noise figure
- An RF sensing circuit allows use with transceivers
- Built-in 117 volt AC Power Supply
- Connecting Coaxial cable for transceiver included

\$89.50



LOOP ANTENNA

- Low noise reception
- Nulls out interference
- Accurate direction finder
- Rotates 360° in azimuth.
Tilts ± 90° in elevation.
- Superb nulls
- Loop amplifier connects to your receiver or to your VLF converter.
- Plug-in loops available for:
1600-5000 KHz (160/80 meter amateur bands)
550-1600 KHz (Broadcast Band)
150-550 KHz (VLF, 1750 meter band)
40-150 KHz (WWVB, Loran)
10-40 KHz (Omega)



**Loop Amplifier \$67.50,
Plug-in loops \$47.50 each**
(specify frequency band)

AUTHORIZED DEALER

Vhf engineering

Makers of the World's Most Complete Line of VHF-FM Equipment

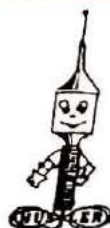

**IT'S MORE FUN
WITH A**

HUSTLER

**MADISON
ELECTRONICS SUPPLY, INC.**

1508-C MCKINNEY
713/658-0268

HOUSTON, TEXAS 77002
Nites 713/497-5683



RATES Regular classified is available at 50¢ per word. Display classified (1 inch deep x 2 1/4 inches wide) is \$50, or at the 12x rate is \$35. All Ad Scan payable in advance. No cash discounts or agency commissions allowed.

HAMFESTS Sponsored by non-profit organizations receive one free regular classified ad (subject to our editing). Repeat insertions of hamfest ads pay the standard rate.

COPY No special layout or arrangements available. Material should be typewritten or clearly printed (not all capitals) and must include full name and address. We reserve the right to reject unsuitable copy. *HORIZONS* cannot check each advertiser and thus cannot be held responsible for claims made. Liability for correctness of material limited to corrected ad in next available issue.

DEADLINE 15th of third preceding month.

SEND MATERIAL TO: Ad Scan, Ham Radio Horizons, Greenville, N. H. 03048.

QSL's — TOP QUALITY — Samples 35¢ — Includes Rubber Stamp Info — Ebbert Graphics, Dept. 5H, Box 70, Westerville, Ohio 43081.

TOROIDS 88 or 44 mH. Same day shipment. 5 for \$3.50 postpaid. Gull Electronics, 12690 Rt. 30, N. Huntingdon, PA 15642.

MOBILE IGNITION SHIELDING provides more range with no noise. Bonding strap sale less than 50¢ each. Literature. Estes Engineering, 930 Marine Drive, Port Angeles, Wash. 98362.

FREE! FREE! FREE! Reusable ring sizer and full color brochure showing the unique 10 Karat Gold A.R.O. Unity Ring. Write to: Group III Sales Co., P.O. Box 259, Little Neck, N.Y. 11362.

WANT UP-TO-DATE INFORMATION? Radio-Hobbyist Newsletter issued every two weeks. Only \$5/year. W5YI; Box #1171-G, Garland, Texas 75040.

ENGRAVED NAMETAGS 1 1/2" x 2 1/2" — \$3.00. QTH added \$0.50. Door plates, key tags available. Black, blue, red, walnut with white letters. Other colors available. Tag-it Co., Box 2062, Indianapolis, IN 46206.

QSLs with class! Unbeatable quality, reasonable price. Samples: 50¢ refundable. QSLs Unlimited, 1472 SW 13th Street, Boca Raton, FL 33432.

CUSTOM EMBROIDERED EMBLEMS — Your design, low minimum. Informational booklet. Emblems, Dept 65, Littleton, New Hampshire 03561.

CODE PRACTICE CASSETTES. Proven method, best price. 0-5 wpm, 5-13 wpm, 13-15 wpm, 20-22 wpm, 25-30 wpm, 30-35 wpm. \$3 each, 4/\$10.00. Amateur Radio Station belt buckles, Call engraved, \$10.00 each. Royal, Dept. B, P.O. Box 2714, Sandusky, Ohio 44870.

MARYLAND: Mountain A.R.C. Silver Jubilee from 0000 GMT November 4th to 2400 GMT November 5th, 1978. Work stations only once, regardless of band or mode and exchange RS(T) and QTH (state or country). Frequencies: 3540, 3910, 7040, 7240, 14040, 14295, 21110, 21360, 28110, and 28600. A special multi-colored QSL card for contact with club station W3YMW, and Silver Jubilee Certificates to any amateur who makes five contacts with members of the M.A.R.C. Mailing deadline December 31st; #10 S.A.S.E. for QSL, large envelope for Certificate. John Fanelli, Jr., WA3WSW, 609 Piedmont Ave., Cumberland, MD 21502.

COMPUTER GENERATED CODE TAPES

New FCC type code test format with over 25 different Ham QSO's on each cassette! **General/Advanced** — 15 WPM, 80 minutes of actual copy. **Extra Class** — 22.5 WPM, 80 minutes of actual copy. **\$5.95** postpaid or both tapes **\$9.95** postpaid. Free printout of copy included to check your copy. Write COMPU-CODE, 113 Starlite Dr., Plano, TX 75074.

NEW CONCEPT — Novice instructional package, theory tape & study material. Complete license study package, \$17.95. General study package, \$19.95. MARI, 1320 Canary Drive, West Columbia, SC 29169.

PENNSYLVANIA: The RF Hill ARC announces Winter Indoor Hamfest II on Nov. 12, 1978 at the Sellersville National Guard Armory, Rte. 152 (Park Ave.), Sellersville, PA. All indoors, heated. Refreshments. Talk-in on 52 and 28/88. 9AM to 5PM. Donations \$2.00, XYL's free. Dealers \$3.00 — bring own tables. Door prizes. For info write Sam Cox, WA3IUH, P.O. Box 29, Colmar, PA 18915.

STOP LOOKING for a good deal on amateur radio equipment — you've found it here — at your amateur radio headquarters in the heart of the Midwest. We may not have a toll free number but we'll save you more in the long run! We are factory-authorized dealers for Kenwood, Drake, Yaesu, Collins, Wilson, Ten-Tec, Atlas, ICOM, DenTron, MFJ, Tempo, Regency, Hy-Gain, Mosley, Alpha, Cushcraft, Swan, and many more. Write or call us today for our low quote and try our personal and friendly Hoosier service. **HOOSIER ELECTRONICS**, P.O. Box 2001, Terre Haute, Indiana 47802. (812) 238-1456.

MARYLAND: The Columbia Amateur Radio Association's 2nd annual Hamfest is on Sunday, November 26, 1978 at the Laurel Raceway, three miles north of Laurel on Rt. #1, beginning at 8AM, admission \$2, tables \$5. Food services, prizes, giant flea market. All indoors. Talk-in 147.735/135, 146.16/76, 146.52/52. CB channel 1. For information and reservations write: Sue Crawford, N3SC, 6880 Mink Hollow Road, Highland, Maryland 20777.

NAMETAGS — 1" x 3" \$3.25. Engraved with name, call letters, QTH. Limit 20 letters per line. Red, blue, yellow, black, walnut with white letters. Other colors available. Nielsen Communications, Inman, Nebraska 68742.

HAMS CASH IN ON CB REPAIR. Unique approach requires NO electronic knowledge and simple equipment you already have in the shack. Write **CB CITY-H**, 6241 Glade, Suite L-303, Woodland Hills, CA 91367.

ALIGNMENT! Alignment and check out of your transmitter or receiver by our FCC licensed technician. Transmitters checked for harmonics, spurious emissions, chirp etc. Fast service and professional work. Only \$15 plus shipping. Send radio with check in reusable carton (insured) to: Wolverine Radio, Box 426, Portage, MI 49081. Thank you.

ELECTRONIC BARGAINS, CLOSEOUTS, SURPLUS! Parts, equipment, stereo, industrial, educational. Amazing values! Fascinating items unavailable in stores or catalogs anywhere. Unusual FREE catalog. ETCO-059, Box 762, Plattsburgh, N.Y. 12901.

MASSACHUSETTS: The Framingham Radio Club announces Massachusetts' largest indoor flea market on Saturday, November 11, 1978. Come and join the fun from 10 AM until ?, rain or shine, at the Drill Shed, 81 Union Avenue, Framingham, Massachusetts (behind the Framingham Police Station). \$1 entry fee, \$5 for table rental in advance. Exhibitors call Jon Weiner (617) 877-7166 for table reservations. Talk in on 75/15 or 52 direct.

CUSTOM Printed and photo QSL's, very economical; free samples, stamp appreciated. Stu, K2RPZ, Box 412, Rocky Point, N. Y. 11778. (516) 744-6260.

CODE PRACTICE OSCILLATORS, hand keys, electronics keyers, other products. Free catalog. Globalman (W6PHA) Products, Box 246, El Toro, CA 92630. 714-533-4400.

THE "CADILLAC" of QSL's! — New! Samples: \$1.00 (Refundable) — **MAC'S SHACK**, Box #1171-G, Garland, Texas 75040.

OFFICIAL RADIO CALL PLATES — Order high quality call plates with pressure sensitive adhesive backs to display your radio call. Durable plastic plates are 3/4" x 1-3/4" black surfaced with choice of red, white, or yellow letters. Plates conveniently stick to radio and test equipment. Send \$1.50 per plate, postpaid in United States, include your FCC or FAA call. **NELSON ENGRAVING CO.**, DEPT. C, P.O. Box 53952, Lafayette, LA 70505.

QSL CARDS 500/\$10. 400 illustrations, sample. Bowman Printing, Dept. HRH, 743 Harvard, St. Louis, MO 63130.

WANTED: Collins 51S-1 cabinet. W9JUV, Box 406, Glenview, IL 60025.

REPAIRS BY N2MB, NEW YORK AREA, First Class Commercial license, Amateur extra, in business 20 years — Radio Clinic, N2MB (formerly WA2BIT). 212-327-4952.

OHIO: Massillon A.R.C. to hold its 17th Annual Hamfest on Sunday, November 19th. Send for FREE brochure to M.A.R.C., P.O. Box 73, Massillon, Ohio 44646.

NEW

THE RADIO AMATEUR ANTENNA HANDBOOK by William I. Orr, W6SAI and Stuart D. Cowan, W2LX

RP-AH Brand NEW! One of Amateur Radio's most notable authors Bill Orr, W6SAI has combined his efforts and knowledge with W2LX to provide you with a clearly written, understandable book on antennas. All types of beam, quad, horizontal and sloping wire antenna information is included in this super volume. Location decisions, height, ground loss, towers, rotors, SWR meter reading — it's all here in one great book. 146 illustrations, charts and diagrams. A new book you have just got to read!...190 pages...©1978. **Softbound \$6.95**

Z-80 MICROCOMPUTER HANDBOOK by William Barden, Jr.

21500 Zilog Model Z-80 represents a microprocessor that has become extremely sophisticated and useful to many computer buffs. This brand new volume is organized into three sections, the first concentrates on hardware; the second on software; and the third on microcomputers built around the Z-80. This handbook will provide the current user and the prospective user with essential information on the fascinating technology of the Z-80. 304 pages...©1978. **Softbound \$8.95**

LOG BOOK New from HRCB

HR-LB Here is the finest book you've ever used. 80 big pages of clear, legibly ruled stock, all spiralbound to lie flat for easy writing. You'll find room for your entries on both sides of each page, thus giving you twice as much space and for less cost than the log book you are probably using now. This is unquestionably the best log book value anywhere. 8-1/2 x 11 size...80 pages. **Spiralbound \$1.50**

RADIO ANGELS by Paul Jerome Stack, WA6JPF

HR-RA This brand new, exciting book depicts the heroic, glorious efforts of Amateurs around the world serving their fellow man during the times of need. Daring rescues, emergency assistance and human compassion all in one super volume. This book was over two years in the making. Get your thrilling copy now!...160 pages...©1978. **Softbound \$4.50**

303 DYNAMIC ELECTRONIC CIRCUITS by Frank Tedeschi and Raymond McIntyre

T-1060 Complete circuit descriptions, detailed schematics, parts lists, modification instructions and efficient application ideas — this new book has circuits for nearly everything. Applications for automobiles, games, hobbies, electronic organs, musical instruments, audio and RF amplifiers, oscillators, detectors, electronic timers, test circuits and computers. If you need a circuit or idea this book has got it...308 pages...©1978. **Softbound \$6.95**



... at last ...
your shack organized!
 A beautiful piece of furniture — your XYL will love it!
\$13995 S-F RADIO DESK
Deluxe - Ready to Assemble
 Designed with angled rear shelf for your viewing comfort and ease of operation.
 FINISHES: Walnut or Teak Stain.
 Also available in Unfinished Birch, \$124.95.
 Additional Information on Request.
 Checks, Money Orders, BankAmericard and Master Charge Accepted.
 F.O.B. Culver City, (In Calif. Add 6% Sales Tax.)
 S-F AMATEUR RADIO SERVICES
 4384 KEYSTONE AVENUE • CULVER CITY, CALIF. 90230 — PHONE (213) 837-4870



Radio equipment not included
 Floor Space: 39" Wide 30" Deep

THIS IS IT
Bird

 MODEL 4431 THRULINE®
RF DIRECTIONAL WATTMETER with VARIABLE RF SIGNAL SAMPLER — BUILT IN
 IN STOCK FOR PROMPT DELIVERY
 AUTHORIZED DISTRIBUTOR
Webster associates
 115 BELLARMINE ROCHESTER, MI 48063
 CALL TOLL FREE 800 — 521-2333
 IN MICHIGAN 313 — 375-0420

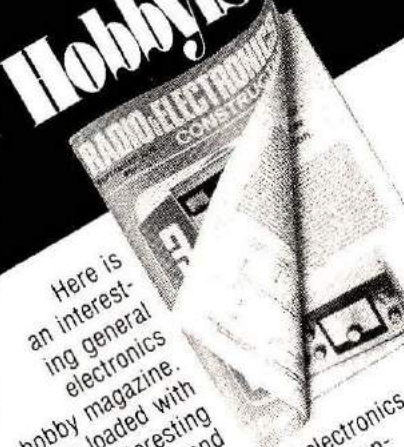
Hobbyists:

 Here is an interesting general electronics hobby magazine. It's loaded with lots of interesting ideas, not only about radio, but in all phases of electronics including test gear, audio, remote control and security systems. We are sure that you will find a number of worthwhile projects in this British magazine.
1 Year (12 issues) \$15.00
Radio & Electronics Constructor
 Greenville, NH 03048

Radio World
 CENTRAL NEW YORK'S FASTEST GROWING HAM DEALER

 Dention ML A 2500 FT 227R 350XL Atlas arma
 FT 101E IC-745 Tempo 2020
 Featuring Yaesu, Icom, Atlas, Dention, Ten-Tec, Swan, Regency, Standard, Tempo, KLM, Hy-Gain, Mosley, Larsen, Midland, Wilson, Southwest Technical Products, Tristao Towers, MFJ, KDK, and Microwave Module. We service everything we sell! Write or call for a quote. YOU WON'T BE DISAPPOINTED.
 We are just a few minutes off the NYS Thruway (I-90) Exit 32
 ONEIDA COUNTY AIRPORT TERMINAL BUILDING ORISKANY, NEW YORK 13424
 Warren K2IXN Bob WA2MSH
 315-337-2622

values from HRCB:

PRICES SLASHED!

**NOW
\$4.95**

~~REGULARLY
\$8.50~~

Order
AR-HB

The ARRL 1978 AMATEUR RADIO HANDBOOK

AR-HB Ham Radio's Communications Bookstore has just acquired a limited number of the current 1978 ARRL Radio Amateur Handbooks at an unbelievably low price — and we are able to pass along a GIANT savings to you! But, you must act now while they last at this fantastic price.

This is your chance to latch onto the most popular and complete Handbook ever printed for the Radio Amateur. In addition to extensive technical coverage, this 664-page volume offers loads of theory, construction and reference information which will be extremely valuable and practical for years to come. 664 pages . . . ©1977.

Softbound \$4.95

At this low price all sales must be final.

Contents include: Amateur Radio, Electrical Laws and Circuits, Radio Design Technique and Methods, Solid-State Fundamentals, AC-Operated Power Supplies, HF Transmitting, VHF and UHF Receiving Techniques, Mobile and Portable/Emergency Equipment and Practices, Code Transmission, Amplitude Modulation and Double-Sideband Phone, Single-Sideband Transmission, Frequency Modulation and Repeaters, Specialized Communications Systems, Interference with other Services, Test Equipment and Measurements, Construction Practices and Data Tables, Wave Propagation, Transmission Lines, Radiation and Antennas, VHF and UHF Antennas, Assembling a Station, Operating a Station, Vacuum Tubes and Semiconductors.

LIMITED QUANTITIES • ORDER NOW

Send to: Ham Radio's Communications Bookstore, Greenville, NH 03048

- | | | | |
|---|--------|--|--------|
| <input type="checkbox"/> AR-HB 1978 ARRL Handbook | \$4.95 | <input type="checkbox"/> 21500 Z-80 Microcomputer Handbook | \$8.95 |
| <input type="checkbox"/> RP-AH Radio Amateur Antenna Handbook | \$6.95 | <input type="checkbox"/> HR-RA Radio Angels | \$4.50 |
| <input type="checkbox"/> T-1060 303 Dynamic Electronic Circuits | \$6.95 | <input type="checkbox"/> HR-LB Log Book from HRCB | \$1.50 |

- Check or Money Order Enclosed
 VISA Master Charge

Total books checked _____, net cost \$ _____
 plus \$1.00 for shipping = TOTAL \$ _____

Acct.

Expires MC Bank

Name _____

Address _____

City _____ State _____ Zip _____

**CALL TOLL FREE
800-258-5353**



Order
RP-AH

Order
21500

Order
HR-LB Order
HR-RA

Order
T-1060

hrcb
am radio's
communications
bookstore

ERICKSON'S MOVED!

Come in and see our new, bigger, and better store. Just a few blocks south of our old location.

YOU'LL FIND the best from

- AEA • Ameco • ASP • Atlas
- Belden • Bencher • Bird
- CDE • CIR • CES • Cushcraft
- DenTron • Drake • Hy-Gain
- Icom • KLM • Kenwood
- Larsen • MFJ • Midland
- Mosley • NPC • Newtronics
- Nye • Palomar • Regency
- Shure • Swan • Standard
- Tempo • Ten-Tec • Tonna
- Transcom • Wilson • Yaesu

NEAR CHICAGO?

COME IN AND SEE US!



Tim WB8SBL and Mike WN9ANF
serving you!



Hours:

9:30-9:00 Mon. & Thurs.

9:30-5:30 Tues., Wed. and Fri.

9:00-3:00 Saturday



Call our new toll-free numbers for the Erickson price.
Illinois, outside 312: (800) 972-5841
Outside Illinois: (800) 621-5802

ERICKSON
COMMUNICATIONS, INC.
5456 N. MILWAUKEE AVE.
CHICAGO, IL 60630 (312) 631-5181

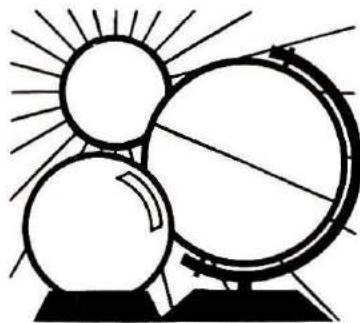

DX FORECASTER

This month will probably not bring many ionospheric surprises. There is a possibility of some minor disturbances between the 5th and the 10th, and again between the 17th and the 23rd. At these times it will be advisable to monitor WWV quite closely for sudden swings in the observed solar flux and geomagnetic field data, as a clue to potential "hot" openings or, conversely, shortwave fades.

Special information

The Leonid meteor shower will take place on the 17th, with a peak of about 15 per hour. However, the moon will be just passing the full stage, and the sky will be bright — perhaps too bright to see any but the brightest meteorites as they enter the earth's atmosphere. Their passage, however, will be apparent to vhf listeners in the form of short bursts of signals reflected from the ionized trails they leave. Full moon occurs on the 15th, and perigee on the 5th.

Contesters will have a heyday in November because every weekend but one has some activity. The 4th and 5th will see the CW portion of ARRL Sweepstakes; the 18th and 19th will be the phone portion of "the sweeps," and CQ's Worldwide DX Contest (CW) will occupy the 25th and 26th. Plan to do most of your sleeping on the "free" second weekend of the month!

Band-by-band forecast

Ten and fifteen meters will be open much of the time, as you will see from the accompanying chart. DX

conditions to many parts of the world will be available to even low-powered stations, and it is worthwhile to point your beam and tune your receivers as shown by the chart.

Twenty meters, as always, will offer the greatest variety of DXers' delights and — at the same time — the greatest frustration because of the fierce competition. You'll want a large beam, tall tower, and kilowatt to be really competitive. However, if your station is more modest, you can still take part by relying on patience and operating skill.

Eighty and forty meters will be coming into their own again for the remainder of the winter, with only short lapses due to high absorption levels at times of disturbed conditions. Begin your listening at dusk and, if you are a night owl, continue until dawn. Between these two times, during the dark hours, DX will be best.

One Sixty is a special case and ought to be quite good during the hours of darkness. Twilight-zone DXing during dawn and dusk is good, too. The chart does not list 160, so you're on your own; check the DX "window" (1825 to 1830 kHz) at the low end of the band to see what's coming through at your location.



Tips on using the chart:

The asterisks (*) mean to look at the next higher band, because it, too, may be open on the path and at the time indicated. The arrows indicate general beam-pointing directions, with north at the top.

HRH

HAM CALENDAR

November 1978

SUNDAY	MONDAY	TUESDAY	WEDNESDAY	THURSDAY	FRIDAY	SATURDAY
<p>*All international events such as contests are shown on the GMT days on which they take place even though they may actually begin on the evening of the preceding day in North America.</p> <p>INTERNATIONAL ASSOCIATION OF AIRLINE HAMs has been set up as an organization of currently employed or retired airline employees, amateurs, and already-hams of over 1300 members. Associate membership is also available to former airline employees or those working in air-related (e.g., FAA positions, FAA, etc.) jobs. For more information, contact the International Association of Airline HAMs, c/o W4DZ, 7020 01002, Monday morning. * info: Carl H. Crumley, N4VD, 517 North Hargrave Avenue Cary, NC 27511.</p>	<p>FLORIDA HAM NEWS — SWAP NET By the Broward ARC 146-31-91 at 7:30PM</p> <p>GLENHURST RADIO SOCIETY Transmits Amateur Radio News — 222 667/224 26 MHz via WR2APG and 21 400 MHz USB</p> <p>WEST COAST BULLETIN Edited & Transmitted by W6ZF BPH PST 3540 KHz, A-1, 22 WPM</p>	<p>AMSAT Eastcoast Net 3850 KHz BPH EST (0100Z Wednesday Morning)</p> <p>AMSAT Mid-Continent Net 3850 KHz — BPH CST (0200Z Wednesday Morning)</p> <p>AMSAT Westcoast Net 3850 KHz BPH PST (0300Z Wednesday Morning)</p>	<p>YL/AP Contest — Phone</p>	<p>TriLium QSO Party — 3-4</p>	<p>ARRL Sweepstakes — CW — 4-5 Frequencies: KC at Greensburg Swap-N-Stop — St. Bruno's Church — Junction of US Rt. 119 and State Rt. 819 — South Greensburg, PA WA3RVD Frequency Measuring Test RSCB 7-MHz Contest — CW — 4-5</p>	4
<p>Fort Meyers ARC Hamatama — Lee County Fairgrounds — North Fort Meyers, FL</p>	<p>FLORIDA HAM NEWS — SWAP NET By the Broward ARC 146-31-91 at 7:30PM</p> <p>GLENHURST RADIO SOCIETY Transmits Amateur Radio News — 222 667/224 26 MHz via WR2APG and 21 400 MHz USB</p> <p>WEST COAST BULLETIN Edited & Transmitted by W6ZF BPH PST 3540 KHz, A-1, 22 WPM</p>	<p>AMSAT Eastcoast Net 3850 KHz BPH EST (0100Z Wednesday Morning)</p> <p>AMSAT Mid-Continent Net 3850 KHz — BPH CST (0200Z Wednesday Morning)</p> <p>AMSAT Westcoast Net 3850 KHz BPH PST (0300Z Wednesday Morning)</p>	<p>West Coast Qualifying Run 0500Z</p>	<p>W/AM Qualifying Run — 0300Z*</p>	<p>ARRL Hudson Div. Convention — Playboy Resort & Country Club at Great Circle, McAfee, NJ — 11-12 Dreadnought Party — By the Delaware ARC — 11-12 — 0001-0600Z 1500-2350Z both days — log deadline 12/15 & SASE for reports to Sandy Curcio, W3JEN, 7 Sorrel Drive, Wilmington, DE 19803 Framingham RC FleaMarket — Drill Shed at rear of Framingham Police Station — 81 Union Avenue — Framingham, MA International Police Assoc. RC, German Section (IPARC) Contest CW & SSB — 0800-1000Z, 1400-1700Z, 1800-2000Z, 11/71 — 0800-1000Z, 1400-1700Z, 1800-2000Z 11/12 — info: SASE (2 stamps) Vince Cumbelo, YB40J, 7606 Kingsbury Road, Alexandria, VA 22310 — DX stations send 2 IRCs.</p>	11
<p>See November 3, 4, 5, 6, 11, 26, 21, 25</p> 	<p>FLORIDA HAM NEWS — SWAP NET By the Broward ARC 146-31-91 at 7:30PM</p> <p>GLENHURST RADIO SOCIETY Transmits Amateur Radio News — 222 667/224 26 MHz via WR2APG and 21 400 MHz USB</p>	<p>AMSAT Eastcoast Net 3850 KHz BPH EST (0100Z Wednesday Morning)</p> <p>AMSAT Mid-Continent Net 3850 KHz — BPH CST (0200Z Wednesday Morning)</p> <p>AMSAT Westcoast Net 3850 KHz BPH PST (0300Z Wednesday Morning)</p>	<p>W/AM Qualifying Run — 0300Z*</p>	<p>W/AM Qualifying Run — 0300Z*</p>	<p>ARRL South Florida Section Convention — Clearwater, FL — 25-26 Breeze Snodder's annual 10-meter ground-wave contest — info: Matt Biernak, N3MB, 752 Jefferson Drive, Pittsburgh, PA 15229 OO Worldwide DX Contest — CW — 25-26</p>	18
<p>Allen Country Amateur Radio Technical Society Hamfest — Allen County Memorial Coliseum — Ft. Wayne, IN</p>	<p>FLORIDA HAM NEWS — SWAP NET By the Broward ARC 146-31-91 at 7:30PM</p> <p>GLENHURST RADIO SOCIETY Transmits Amateur Radio News — 222 667/224 26 MHz via WR2APG and 21 400 MHz USB</p> <p>WEST COAST BULLETIN Edited & Transmitted by W6ZF BPH PST 3540 KHz, A-1, 22 WPM</p> <p>W/AM Qualifying Run — 2100Z</p>	<p>AMSAT Eastcoast Net 3850 KHz BPH EST (0100Z Wednesday Morning)</p> <p>AMSAT Mid-Continent Net 3850 KHz — BPH CST (0200Z Wednesday Morning)</p> <p>AMSAT Westcoast Net 3850 KHz BPH PST (0300Z Wednesday Morning)</p>	<p>Thanksgiving</p> 	<p>Thanksgiving</p>	<p>ARRL South Florida Section Convention — Clearwater, FL — 25-26 Breeze Snodder's annual 10-meter ground-wave contest — info: Matt Biernak, N3MB, 752 Jefferson Drive, Pittsburgh, PA 15229 OO Worldwide DX Contest — CW — 25-26</p>	25
<p>Columbia Area Hamfest — Laurel Race Way — 3 miles north of Laurel, MD on Rt. 1 — info: Sue Crawford, N3SC, 6880 Mink Hollow Road, Highland, MD 20777 Oak Park High School Electronics Club Swap-N-Stop — Oak Park High School — Oak Park, MI</p>	<p>FLORIDA HAM NEWS — SWAP NET By the Broward ARC 146-31-91 at 7:30PM</p> <p>GLENHURST RADIO SOCIETY Transmits Amateur Radio News — 222 667/224 26 MHz via WR2APG and 21 400 MHz USB</p>	<p>AMSAT Eastcoast Net 3850 KHz BPH EST (0100Z Wednesday Morning)</p> <p>AMSAT Mid-Continent Net 3850 KHz — BPH CST (0200Z Wednesday Morning)</p> <p>AMSAT Westcoast Net 3850 KHz BPH PST (0300Z Wednesday Morning)</p>	<p>AMSAT Eastcoast Net 3850 KHz BPH EST (0100Z Wednesday Morning)</p> <p>AMSAT Mid-Continent Net 3850 KHz — BPH CST (0200Z Wednesday Morning)</p> <p>AMSAT Westcoast Net 3850 KHz BPH PST (0300Z Wednesday Morning)</p>	<p>AMSAT Eastcoast Net 3850 KHz BPH EST (0100Z Wednesday Morning)</p> <p>AMSAT Mid-Continent Net 3850 KHz — BPH CST (0200Z Wednesday Morning)</p> <p>AMSAT Westcoast Net 3850 KHz BPH PST (0300Z Wednesday Morning)</p>	<p>WORKSHOPS: An expanded and new series of four lecture/laboratory workshops on microcomputer data acquisition, instrumentation and measurement systems are being given by the authors of the popular <i>BUGS</i> books. Course dates are being given by the authors: 1978, Dec. 18-20, 18-21, 18-22, 18-23. For more information, contact Dr. Linda Leifer, Center for Continuing Education, Virginia Polytechnic Institute and State University, Blacksburg, VA 24061 (303) 961-5241.</p>	26
<p>26</p>	<p>27</p>	<p>28</p>	<p>29</p>	<p>30</p>	<p>24</p>	<p>25</p>

Sunspot Cycle Madness

WE'RE CELEBRATING—WITH SUPER DEALS FOR YOU!

THOMAS COMMUNICATIONS



YAESU
FT-7



YAESU
FT-901

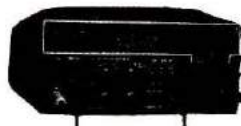

ICOM
IC-701

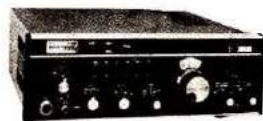

DRAKE
TR-7



KENWOOD
TS-820S



YAESU
FT-227R



TEN TEC
544



PANASONIC RECEIVER
RF 4800

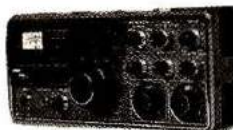

KENWOOD
TS-700SP



KDK
2015R



DENTRON
MLA-2500B



WILSON
MARK IV

"OVER 50 BRANDS IN STOCK"

- KENWOOD • YAESU • KDK • DENTRON • WILSON • MFJ • SWAN • DRAKE • LARSEN •
- TEMPO • KLM • BEARCAT • B & W • ARRL PUBLICATIONS • MOSLEY • REGENCY • ASTATIC •
- CUSHCRAFT • MICROLOG • HAM KEY • CDE • PIPO • ICOM • TEN TEC • PANASONIC •
- DAYBURN INSULATORS • BIRD • AMECO • HUSTLER • CALL BOOK • SAXTON • ALLIANCE •

★ COMPLETE RADIO SERVICE SHOP ★

- FAST EFFICIENT SERVICE — WE REPAIR ALL BRANDS —
- ALL WORK GUARANTEED — AMATEUR EXTRA / FIRST CLASS LICENSES —
- SEND US YOUR DEFECTIVE EQUIPMENT U.P.S. COLLECT —
- FREE SHIPPING BOTH WAYS IF WORK IS DONE —
- MOST REPAIRS DONE AND SHIPPED WITHIN 7 DAYS —
- ★ OUR FINE REPUTATION SPEAKS FOR ITSELF ★

"YOU SHIP IT — WE FIX IT"

- ★ NEW AND USED EQUIPMENT — "Get on our used equipment mailing list" —
- ★ TRADES WELCOME — "The best allowances anywhere" — "We buy good used SSB gear" —
- ★ FREE CATALOG — "Prices of all major manufacturers" —
- ★ SAME DAY U.P.S. SHIPPING — "Just a phone call away" —



Telephone Orders
203-667-0811
Call Today!

Call or write for
your super quote today!



THOMAS COMMUNICATIONS - "Near ARRL Headquarters"

95 KITTS LANE, NEWINGTON, CONNECTICUT 06111

OPEN MON.-FRI. 10-6 • THURS. 10-8 P.M. • SAT. 10-4

EASY DIRECTIONS: Rt. 15 South — 2 blocks past McDonald's (Berlin Turnpike)

AD CHECK

... for literature, in a hurry — we'll rush your name to the companies whose names you check.

Place your check mark in the space between name and number. Example: HRH 150.

Antenna Spec. <input type="checkbox"/> 010	Icom <input type="checkbox"/> 065
Atlas <input type="checkbox"/> 198	Int. Crystal <input type="checkbox"/> 066
Atronic <input type="checkbox"/> 382	Kantronic <input type="checkbox"/> 605
Bencher <input type="checkbox"/> 629	Kenwood *
Bob's A.R.C. <input type="checkbox"/> 695	Long's <input type="checkbox"/> 468
CW Elec. <input type="checkbox"/> 533	MFJ <input type="checkbox"/> 082
Cohoon <input type="checkbox"/> 559	Madison *
Colorado Silver <input type="checkbox"/> 630	Palomar Eng. *
Comm. Center <input type="checkbox"/> 534	Panasonic <input type="checkbox"/> 683
Cornell-Dublier <input type="checkbox"/> 241	Partridge <input type="checkbox"/> 439
Cosmic Search <input type="checkbox"/> 718	Pathcom <input type="checkbox"/> 705
Cover Craft <input type="checkbox"/> 685	Personal Comm. Found. *
Cushcraft * <input type="checkbox"/> 656	RSE Ham Shack <input type="checkbox"/> 607
DSI <input type="checkbox"/> 656	Callbook <input type="checkbox"/> 100
DenTron <input type="checkbox"/> 259	Constructor <input type="checkbox"/> 586
Drake * <input type="checkbox"/> 111	Radio World *
E.T.O. * <input type="checkbox"/> 693	S-F A. R. S. <input type="checkbox"/> 640
Erickson * <input type="checkbox"/> 691	Swan <input type="checkbox"/> 111
G.I.S.M.O. <input type="checkbox"/> 691	Telex <input type="checkbox"/> 693
Great Lakes A.S.C. <input type="checkbox"/> 732	Ten-Tec *
Hal <input type="checkbox"/> 057	Thomas Comm. <input type="checkbox"/> 730
"Ham" Buerger * <input type="checkbox"/> 491	Universal Mfg. <input type="checkbox"/> 684
H.R.C.B. <input type="checkbox"/> 150	Webster Assoc. <input type="checkbox"/> 423
Horizons <input type="checkbox"/> 150	Webster Radio <input type="checkbox"/> 255
Harrison <input type="checkbox"/> 575	Western *
Heath <input type="checkbox"/> 060	Wilson <input type="checkbox"/> 123
Henry <input type="checkbox"/> 062	ZZZ <input type="checkbox"/> 720

*Please contact this advertiser directly.

Limit 15 inquiries per request.

NOVEMBER 1978

Please use before December 31, 1978

Tear off and mail to
HAM RADIO HORIZONS — "Ad Check"
 Greenville, N. H. 03048

NAME _____

CALL _____

STREET _____

CITY _____

STATE _____ ZIP _____

MADISON BIG TURKEY SPECIALS

OMNI-J 2-meter mobile or portable antenna, 3/8" thread, 5-dB gain (1.5-dB gain over conventional 5/8-wave mobile whip antenna) **\$39.95**; 220-MHz **\$37.95**; 450-MHz **\$37.95**. Guaranteed results.

TRI-EX W-51 (51-foot) self-supporting tower; regular **\$825**, your cost **\$725** FOB California.

F9FT TONNA antennas: 144/16 element **\$65.95**
 9/19 OSCAR **\$63.00**

RIW 432-MHz/19-element yagi **\$59.95**
KLITZING VHF/UHF amplifiers

2-meter: 10w. in - 100w. out **\$179.95**
 432 MHz: 10w. in - 50w. out **\$189.95**

BIRD MODEL 43 wattmeters, plus slugs, in stock, prepaid UPS

KLM: Antennas, Linears, Accessories, All In Stock
FREE balun with 2-meter base antenna.

MICROWAVE MODULES MMT 432-28S **\$259**, UPS Paid.

TELREX TB5-EM triband beam antenna **\$415** in stock.



PALOMAR ENGINEERS: Transceiver preamplifier **\$89.50**

BENCHER keyer paddles **\$39.95** in stock
 chrome **\$49.95**

ETO ALPHA 76 amplifiers, in stock **call or write**

LUNAR: 6m - 2m - 220 MHz in-line preamplifiers **\$49.95**
 2m amplifier w/preamplifier, 10w. in - 80w. out **\$189.95** UPS PAID

JANEL QSA-5 preamp **\$41.95**

ROBOT items, in stock **call or write**

CDE: **HAM III, \$129; HAM X, \$249**



8-wire rotor cable, heavy duty, #9405 (2-no. 16, 6-no. 18) for long runs, 26c ft.; 8448 Std. 8-wire cable, 16c ft.; 9888 double shield RG-8 foam, 25c ft.; 8237 RG-8, 21c ft.; 8267 RG-213, 25c ft.

AMPHENOL Silver Plated PL-259 connectors **59c** each

TIMES: 1/2" foam hardline 60c ft., connectors **\$15** each
 7/8" foam hardline **\$1.50** ft., connectors **\$25** each

BERKTEK RG-8X 52-ohm, KW, **16c** ft.

VHF ENGINEERING: Blue Line Amplifiers, in stock **call or write**

AEROVOX: 1000 pF/500V. feed-thru capacitors **\$1.95** ea.

CETRON 572B **\$27.95** each

RAYTHEON 572B **\$24.95** each

GE receiving tubes, **50% off list**

GE 6146B, 8950 **\$7.95** each

TECHNICAL BOOKS: AMECO, ARRL, Sams, TAB, TI, Rider, Radio Pub., Callbook, Cowan, TEPABCO, many others in stock. **call or write**

CRAZY BUYS: BEARCAT 260 SCANNER **\$292**

CALL FOR QUOTES ON: KENWOOD TS-820S, TS-520S, TR-7400A, YAESU FT-901DM, FT-625RD, ALDA, AMCOMM, VHF ONE PLUS & ETO ALPHA. ALL IN SEALED CARTONS. CALL FOR QUOTES ON ITEMS NOT LISTED.

**CALL FOR FAST QUOTES
SPECIAL ORDERS WELCOME**

TERMS: All prices FOB Houston. Prices subject to change without notice. All Items Guaranteed. Some items subject to prior sale. Send letterhead for Amateur dealers price list. Texas residents add 6% tax. Please add postage estimate.

**MADISON
ELECTRONIC SUPPLY, INC.**

1508-C MCKINNEY HOUSTON, TEXAS 77002
 713/658-0268 Nites 713/497-5683

AD INDEX

Antenna Specialists	70
Atlas Radio Company	47
Atronic	84
Bencher, Inc.	63
Bob's Amateur Radio Center	77
CW Electronic Sales Company	65
Cohoon Amateur Supply	79
Colorado Silver Co.	78
Communications Center	81
Cornell-Dublier Electric Co.	69
Cosmic Search	71
Cover Craft	80
Cushcraft	4, 37, 43, 53
DSI Instruments	60, 61, 67
DenTron Radio Company	48, 49
Drake Co., R. L.	Cover II, 78
Ehrhorn Technological Operations	95
Erickson Communications	90
G.I.S.M.O.	70, 78
Great Lakes Am. Supply Co.	76
Hal Communications Corp.	9
"Ham" Buerger	71
Ham Radio Center	73, 80
Ham Radio's Communications Bookstore	63, 74, 88, 89
Ham Radio Horizons	70
Harrison Radio	75
Heath Company	Cover IV
Henry Radio Stores	85
Icom	7
International Crystal	29
Kantronic	80
Trio-Kenwood Communications Inc.	Cover III
Long's Electronics	1
MFJ Enterprises	3
Madison Electronic Supply	86, 94
Palomar Engineers	41
Panasonic	72
Partridge Electronics Ltd.	78
Pathcom, Inc.	84
Personal Communications Foundation	64
RSE Ham Shack	63
Radio Amateur Callbook	76
Radio & Electronics Constructor	88
Radio World	88
S-F Amateur Radio Services	88
Swan Electronics	65
Telex Communications, Inc.	28
Ten-Tec	54, 55
Thomas Communications	93
Universal Manufacturing Corp.	76
Webster Associates	88
Webster Radio	96
Western Electronics	63
Wilson Electronics	10
ZZZ Electronics, Inc.	84

Foreign Subscription Agents for Ham Radio HORIZONS

Ham Radio Austria
 Karin Ueber
 Postfach 2454
 D-7850 Loerrach
 West Germany

Ham Radio Holland
 MRL Ectronics
 Postbus 88
 NL, 2204 Delft
 Holland

Ham Radio Belgium
 Stereohouse
 Brusselsstraatweg 416
 B-9218 Gent
 Belgium

Ham Radio Italy
 STE Via Maniago 15
 I-20134 Milano
 Italy

Ham Radio Canada
 Box 114, Goderich
 Ontario, Canada N7A 3Y5

Ham Radio Switzerland
 Karin Ueber
 Postfach 2454
 D-7850 Loerrach
 West Germany

Ham Radio Europe
 Box 444
 S-194 04 Upplands Vasby
 Sweden

Ham Radio UK
 P.O. Box 63, Harrow
 Middlesex HA3 6HS,
 England

Ham Radio France
 Christiane Michel
 F-89117 Parly
 France

Ham Radio Germany
 Karin Ueber
 Postfach 2454
 D-7850 Loerrach
 West Germany

Holland Radio
 143 Greenway
 Greenside, Johannesburg
 Republic of South Africa



Mt. Sopris, Colorado — In ETO's "back yard". Photo by Douglas J. Martin

ALPHA POWER... Rugged, Cool & Quiet

When you buy an ALPHA linear amplifier you make a long term investment in dependable power and operating pleasure.

You can take your ALPHA for granted — it will go on delivering that big, clean, maximum-legal-power signal no matter how tough the contest or how long the SSTV or RTTY QSO's.

We strive constantly to make every ALPHA even better. If we can't improve it, we don't change it.

DURABILITY? You get TWO YEARS of factory warranty protection with your new ALPHA . . . other manufacturers give you 90 days.

CONVENIENCE? Every ALPHA is self-contained, compact, and smooth-tuning. All 76A - 374A - 78 models can be shipped via economical, door-to-door UPS.

VERSATILITY? The new ALPHA 374A delivers full legal power (in any mode) on all amateur HF bands WITHOUT TUNE-UP and with excellent efficiency. (On 160M you peak the output manually; new FCC rules permit easy owner modification to restore full 10M capability, too.)

The ALPHA 78 combines the best of everything: full instant CW break-in (QSK) and NO-TUNE-UP bandchange! And of course all ALPHAs substantially exceed every applicable FCC requirement.

For detailed literature and fast delivery of your new ALPHA, contact your dealer or ETO direct. While you're at it, ask for a free copy of our brief guide, *"Everything You Always Wanted to Know About (Comparing) Linears . . . But Didn't Know Whom to Ask."*

ALPHA — Sure you can buy a cheaper linear . . . But is that really what you want?



Ehrhorn Technological Operations, Inc.
P.O. Box 708 • Cañon City, Colorado 81212 • (303) 275-1613

Call Webster FREE (800) 344-2198

top lines - lowest prices!



ICOM Transceiver 2M FM
IC 245 **SPECIAL PRICE \$429.95**

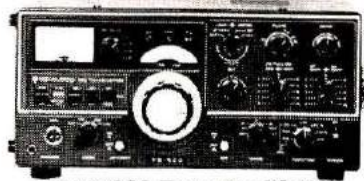

KENWOOD Transceiver TS-520S
160 thru 10M "Surprise...call us!"



ICOM Transceiver 2M FM SSB
IC 211 **SPECIAL PRICE \$649.95**

YAESU



YAESU FT-227R
2 Meter FM \$349. *Call for Your Price!*

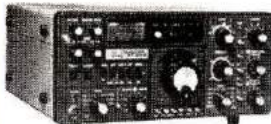

YAESU FT-901DM
160 thru 10M \$1459.
Call for Your Price!



YAESU HF SSB
FT-101E, 160 thru 10M \$799.
Call for Your Price!

Super Signal Savings!

TOWERS
TRISTAO CZ-454
Reg. \$825. **SALE \$660.**
TRI-EX W51
Reg. \$825. **SALE \$660.**
Total Tower lines available.

ROTORS
CD44 \$154.95 - **SALE \$94.95**
Ham X \$349.95 - **SALE 229.95**

4 EXAMPLES OF BIG SAVINGS



KENWOOD Transceiver
TS-820S 160 thru 10M
Call for Special Price Combo!

NOW IN STOCK...
the ultimate in
receiver perfection -
Kenwood R-820. *Call for price.*

DRAKE



DRAKE TR-7/DR-7 \$1295
PS-7 \$195.
Call for Your Price!

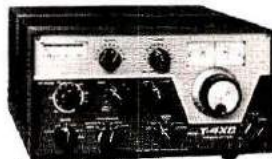

DRAKE TX T-4XC \$699.
RX R4C \$699 160 thru 10M
Call for Your Price!



YAESU Receiver
FRG-7 Broadcast to 30 Mhz \$370.
Call for Your Price!

ICOM



ICOM IC-701S, 160 thru 10M
Special Price \$1299.95

ROTORS

Ham III
Reg. Price \$194.95

NOW ONLY \$114.95



Prices subject to change without notice!

KENWOOD



KENWOOD
TL-922 \$1100. *Call for Your Price!*

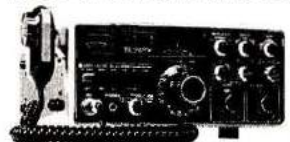

KENWOOD FM/SSB
TS-700SP \$729 *Call for Your Price!*



KENWOOD 2M FM
TR-7400A \$399. *Call for Your Price!*

ICOM



IC-280 Transceiver
Special
Introductory
Offer
\$369.95



IC-RM2
Computer-
Controller for
701, 211, 245
SSB
\$154.95

Webster
HAM-A-GRAM
Don't worry about inflation...
Webster's prices are
lowest in the nation!

FT-202
Hand-held
Transceiver
\$199
Call for Your Price!

2602 E. Ashlan, Fresno, CA 93726 / Ph. (209)224-5111
HOURS: 9 a.m. to 6 p.m. - Mon. thru Fri. / 9:30 a.m. to 5:30 p.m. - Sat.

Webster radio, inc.

The TS-520S,
the most popular
Amateur Radio transceiver
in the world

... provides a foundation
for an expanding series of acces-
sories designed to please any ham ... from
Novice to Amateur Extra.

TS-520S

The TS-520S transceiver provides full transmit and receive coverage of all Amateur bands from 160 through 10 meters. It also receives 15.0 (WWV) to 15.5 MHz and another 500-kHz range of your choice in the auxiliary band position. With the optional DG-5, you have a large digital frequency readout when transmitting and receiving, and the DG-5 also doubles as a 40-MHz frequency counter. The TS-520S includes a built-in AC power supply, and, with the addition of the optional DS-1A DC-DC converter, it can function as a mobile rig. It features a very effective noise blanker, RIT, eight-pole crystal filter, 25-kHz calibrator, front-panel carrier level control, semi-break-in CW with sidetone, built-in speaker, heater switch, 20-dB RF attenuator and easy phone-patch connection. RF input power is 200 W PEP on SSB and 160 W DC on CW. Carrier suppression is better than -40 dB and sideband suppression is better than -50 dB. Spurious radiation is less than -40 dB. Receiver sensitivity is 0.25 μ V for 10 dB (S+N)/N. Selectivity is 2.4 kHz at -6 dB/4.4 kHz at -60 dB and, with the optional CW-520 CW filter, is 0.5 kHz at -6dB/1.5 kHz at -60 dB.

See your local Authorized Kenwood Dealer for more information, and a super deal!



AT-200

SP-520

TS-520S

VFO-520S TV-502S TV-506

A great station ... at an affordable price! The TS-520S with its companion accessories ... including two new units. The AT-200 antenna tuner provides a versatile tool in any station. The other is the TV-502S, Kenwood's 2 meter transverter for SSB and CW operation from 144 to 146 MHz.



The **HEATHKIT**® HW-8it works the world on a couple of watts!

In 1977 Norm North, WA1DBR, was assigned to Thule, Greenland. With him went his Heath HW-7, a dipole antenna, and a goal... work all 50 states! Norm failed! But what he did accomplish in three months time, with his HW-7 and the call OX5AB, is nothing short of amazing! Worked: 41 states, 30 countries, including a PY4 in Belo Horizonte, Brazil, and First Place, High-Band CW Greenland, in the '77 ARRL International DX Competition! Quite a record!

In Norm's words: "I honestly believe that I could have worked all states and perhaps DXCC if I had stayed in the Arctic a bit longer. This is quite a tribute to that little rig..."

We'd agree, and we bet Norm would have done even better had he been using a new Heath HW-8! Why? Because our engineers felt they could give you a much finer QRP rig than the HW-7. One with

If card is missing, write Heath Company, Dept. 348-470, Benton Harbor, Michigan 49022

better sensitivity, lower hum and noise figures, an RF gain control, sharper preselector, switchable selectivity, more bands to operate, and even a bit more power!

They succeeded in a big way! And the result of their efforts is a truly superb CW transceiver for the QRP operator that costs just \$129.95*... the Heath HW-8! Why don't you take up the challenge? Ask the guy who's built an HW-8 kit, then join the growing ranks of outstanding QRP operators, like Norm, who are proving - you really can work the world on a couple of watts!

Read about nearly 400 kits you can BUILD YOURSELF for pride, satisfaction and savings!

Use the card to send for your Brand-new Heathkit Catalog TODAY!



FREE

*Price is mail order net F.O.B., Benton Harbor, Michigan. Prices and specifications subject to change without notice.

AM-380