

MAY 1961

40 CENTS

TELEVISION HORIZONS

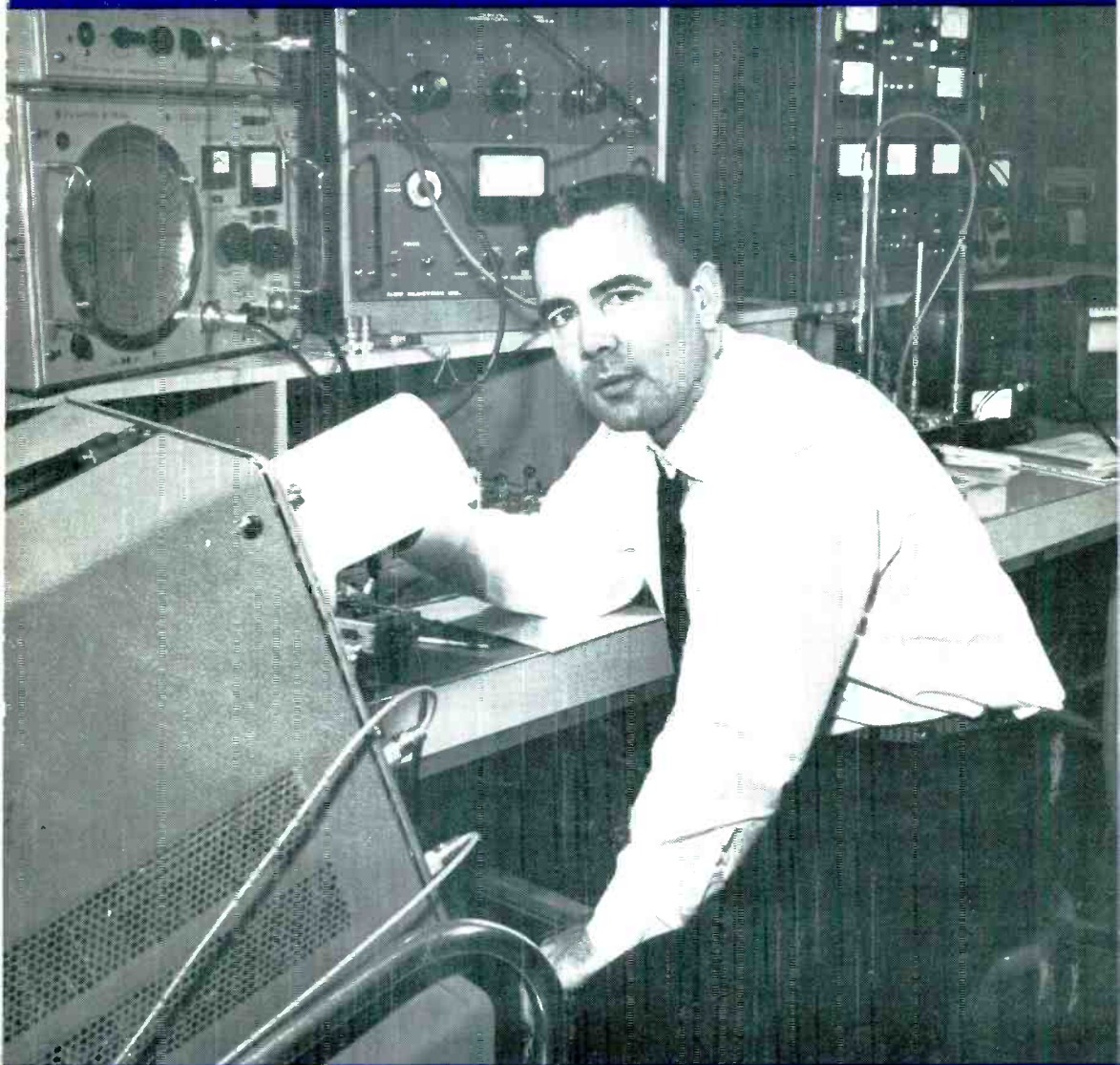

DEVOTED ENTIRELY TO TELEVISION RECEPTION

Al Bowdy, KOOP Television
915 N. La Brea Ave.
Los Angeles 38, Calif.

MAN BEHIND THE POWERTRON

JOHN R. WINEGARD, President
Winegard Antenna Company
Burlington, Iowa



It's easy to add the new JERROLD FM equipment package

Now you can take advantage of the boom in FM listening! Add the extra value of one or more FM channels to your present cable service—economically! Here's all you need to get extra subscriber-appeal:

- FM antenna
- FM tuner
- FM modulator for originating your own audio (record, tape, microphone)
- In-the-home FM tap
- For weak-signal areas only, an FM pre-amp

All the components are Jerrold-made with the exception of the antenna and the Scott 310DR Tuner, which we've selected as an integral part of the package. If your system has Jerrold trunk-line equipment manufactured during the past three years, *no* adjustment should be needed for adding FM. Only minor amplifier realignment is needed on earlier equipment.

Give your present subscribers more, and you'll attract more subscribers. FM radio will add a valuable *plus* to your CATV system.

Here's how simple it is to add FM to your system

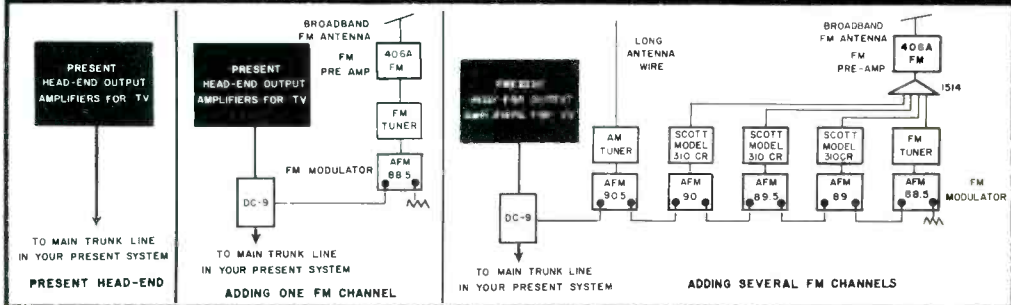

ORDER FROM YOUR JERROLD FACTORY REPRESENTATIVE or call or write the Jerrold Community Systems Division for full information.



ELECTRONICS CORPORATION

Community Systems Division

The Jerrold Building, Philadelphia 32, Pa. Telephone 215 Baldwin 6-3456



Exclusive and Late News of the TELEVISION RECEPTION INDUSTRY

Big Boost for "U" in Midwest

An avid promoter of UHF in the midwest is behind a recent filing at the FCC which will bring channel 8, KRNT, Des Moines, Iowa into the service area of KQTV-21 in Fort Dodge, Iowa. KQTV operates with 330 kw. ERP into a directional antenna which beams the signal north and northeast. KQTV is an NBC affiliate. The translator promoter, well known in the midwest, has received the backing of the station to bring the CBS signal of KRNT-Des Moines into the market on channel 70. Translator will operate with 660 watts ERP, and work from the tower of KQTV! The channel 70 signal is expected to provide comparable coverage out to 25 miles in the same directional pattern now used by KQTV. If the coverage of the new translator proves up to expectations, FCC will be petitioned to allow the unit to move "down the band" closer to the channel 21 frequency of KQTV and operate as a "semi-satellite" of KRNT.

Nebraska to Use "U" Translators ... Education

If all goes well the cities of York, Hastings-Grand Island and Kearny, Nebraska will be within the range of 26 kw. educational TV KUON in Lincoln by late summer. UHF translators will literally "ring" the KUON coverage area to greatly increase the region of impact for the state's only educational TV outlet. If the initial plans for York, etc. work out as envisioned, other installations are scheduled to cover Omaha and Columbus, Nebraska. The state's educators will foot the bill.

Strange Translator Application

FCC reportedly is looking with careful eye at a recent UHF translator application for

Columbus, North Dakota. The Columbus Lions Club is behind the project, according to papers filed with the Commission. However the applications branch feels there may be more to the application in light of a planned Canadian CATV system for Estevan, Saskatchewan, just north of Columbus, N.D.

CATV Depreciation

One of the biggest problems currently confronting this nation's CATV operators is five year depreciation. Under the governments tax depreciation set-up, a goodly number of CATV operators are finding their initial investments about written off this year, and hence the move to dispose of CATV properties to large holding companies (i.e., *H&B American, Teleprompter, etc.*). However the problem does not end here. Many smaller systems provide their operators with good yearly revenue which they hate to part with, even in light of fair to good sale prices which are being paid for systems.

One possible solution is expansion, and completely underwriting the entire system all over again. One of the most popular "expansion regions" around these days is closed circuit educational and (to a small extent) local origination television.

Whatever the solution, as dictated by individual owner requirements, the problems of tax depreciation and system ownership are due for considerable talk time at the *National Community Television Association's* CATV convention in San Francisco.

More CATV Microwave

During the Pacific Northwest CATV conclave in Seattle April 17-18 there was considerable talk about the use of microwave in CATV installations (a topic DXH covered in some

detail in a two-part series appearing during December and January). One of the more extensive installations is now under construction in Washington. *Harbor TV* is bringing seven channels on the new 6 Kmc Collins equipped system which will serve Aberdeen and Westport. During the meeting Collins people told *Horizons* Publisher Bob Cooper they expect to begin delivery on a 6 Kmc 1 watt system with a solid state power supply by September 1. The first delivery will go to *Antennavision* for their new Yuma, Arizona installation.

A quartet of microwave CATV applications appeared before the Commission this past month. *Pacific Teletronics*, Medford, Oregon proposes to furnish a three channel service to interconnect with its present system, and to extend its existing system to Klamath Falls, Oregon. All Portland TV channels plus signals from Corvallis and Eugene will be included on the circuit.

Columbia Basin Microwave Company proposes to bring the signals of KCTS and KING Seattle into Moses Lake and Ephrata, Washington. Systems served will be Moses Lake TV and Empire TV.

Southern Transmission Corporation proposes a three channel—four hop and four channel—one hop system across central Texas to supply microwave TV signals to a CATV system in San Angelo, Texas.

Southern Transmission also proposes a three hop system to pick up WFLA, WSUN, and WEDU (Tampa) for a CATV system in Fort Myers, Florida.

Transistors in VHF

As announced elsewhere in this issue of *Television Horizons*, the swing to transistorized amplifiers is well underway. To date transistor units have consisted of set mounting types for general reception and airtight-sealed units for CATV head-ends. Now *Winegard* announces a set of units designed for single channel use as an integral part of the antenna for either low or high band, and an FM model.

Delta Electronics (Toronto) also announces an antenna mounting unit, available in broad band, low band, high band and single channel models.

A major manufacturer of VHF and UHF head-end equipment is reportedly readying antenna mounting unit which combines transistor front end, battery power supply and four set splitter into single package.

Transistors are here to stay... although

some questions must still be answered for those in the field actually using the units.

Benco T12 UHF Translator

The impact of a 3.5 watt UHF translator covering channels 14-83, and priced at under \$2,200.00, has been considerable in the past four weeks. When *Benco Ltd.* of Toronto announced their new unit in these pages last month, inquiries were immediate. Some changes in dealerships have been announced by firms previously handling the *Adler* UHF line of Translators. *Mid-State Radio Supply, Incorporated* of Wenatchee, Washington has filed an application with the FCC to change its experimental UHF authorization from an *Adler UST-10* to the *Benco T-12*. Other changes are also in the wind.

Benco meanwhile has furnished *Horizons Publications* with further data on its model T-11 and T-12 translators. Delivery time for output on channels 74-82 is six weeks. Delivery for channels 14-73 is ten weeks. The T-11 (input channels 2-6, output 14-83) is priced at \$2,020.00. The T-12 (input 7-13, same output range) is priced at \$2,160.00. Transmitter portion uses a pair of EC55 tubes in machined cavities.



John Walker, Chief Engineer for Harbor Television, Washington State gave the once over to his "new toy," a Collins seven channel microwave installation, during the Seattle CATV Conference April 18.

FCC APPROVES FM STEREO

On April 19 the Commission approved a set of standards for FM stereo operation of a multiplex basis. The order will become effective June 1, 1961. The multiplex system approved is basically "that proposed by Zenith Radio and GE" according to the Commission. Full details in June.

OUR MAN IN WASHINGTON

Forty-Five Minutes with Commissioner Robert E. Lee

(Washington—April 10)

The Commissioner had just returned from a conference he did not wish to elaborate on. As an old "editorial friend" of the man who one day envisions an all UHF television picture in the United States, we were warmly received and quickly got down to brass tacks (topics as it were).

Our first topic of discussion centered around the present shifting of the TV winds in Central California where an intermixed situation is rapidly disappearing as the "Vs" move to UHF. We asked the Commissioner if he expects any difficulty in moving channel 10 Bakersfield (KERO) to channel 23.

His answer, "Yes, I am afraid they are going to put up a fight." How much of a fight, we asked. "Considerable" was the answer.

Next we asked why the channel 10 Bakersfield assignment was moved to the Santa Maria area, as evidence points out that Santa Maria (should it use the channel) would straddle the same mountain range with its transmitter that now shields the southern San Joaquin Valley from other VHF signals. Then, said we, you will have the channel 10 signal right back in the Bakersfield area.

"You know the area better than I do" came the reply.

That we do, we noted, but what is going to be done about it?

"I will look into it" came the promise.

Next we queried about the apparent change in UHF thinking by some members of the Commission. We pointed at the recent vote to make Bakersfield all UHF, on the Commission level, and noted that it was a 5-1 margin in favor. Gone, we noticed were the tried and true 4-3 margins we had been led to expect. Does this, we suggested, indicate that the "new frontier" feels a little different about UHF than the previous Eisenhower stacked Commission?

Commissioner Lee smiled. "I wondered who would notice this" he beamed. "Yes, I think it is safe to say that our program for UHF is gaining strength here on the Commission."

Changing the subject, we asked the Commissioner if he felt the chances for legislation forcing an all-channel VHF and UHF receiver were good during this session of Congress.

After a half minute of deep thought, he

replied "To be perfectly honest with you, no I do not. I am a little skeptical that an all-channel tuner will go through. In fact I am not personally solidly behind the proposed bill, although I am backing it on the surface. I feel the bill is an alibi on the part of the FCC . . . that we are in fact asking Congress to do a job for us that we could do if we only had the gumption." "And" the Commissioner continued, "The manufacturers have a pretty good argument when they tell Congress this is contrary to the free enterprise system. In fact, I think that manufacturers should support this move to UHF purely for economical reasons. Certainly the increased flow of dollars through such a move, in the television receiving industry, would help alleviate our current soft economy."

What about the New York City test, we asked. Do your engineers really believe it will take a full year to complete sufficient measurements to know if UHF will work as well as VHF in the metro region?

Again we could see the Commissioner's face breaking into a hidden though present smile. "My engineers," he began, "expect the evidence will be very plain after one week of testing. After that, the testing will only pile duplicate fact upon duplicate fact. "Incidentally," he added, "those same engineers tell me that UHF will give downtown Manhattan viewers the best picture they have ever seen . . . mark my words!"

Thank you Mr. Commissioner, we replied, WE WILL.

—R.B.C.



OUR MAN IN WASHINGTON . . . found Commissioner Robert E. Lee busily engaged in pressing business, but not too busy to grant us this exclusive interview.



HORIZONS

Formerly *DXing Horizons*

PUBLISHED MONTHLY BY HORIZONS PUBLICATIONS
POST OFFICE BOX 3207 • MODESTO, CALIFORNIA

STAFF

- R. B. COOPER, JR., K6EDX
Publisher-Editor
- THOMAS S. KNEITEL
ART W. BROTHERS, W6IQJ
Associate Editors
- ROBERT D. GRIMM, K6RNQ
Technical Editor
- JAMES BEAMER
VHF Translator Editor
- HARLOW SPECKHART
UHF Translator Editor
-
- JACKIE JOHNSON
Production Coordinator
- STAN SEARLE
Promotion
- SHERRY GREENER
Circulation Manager

OFFICES

1016 - 14th STREET
MODESTO, CALIFORNIA
U.S.A.
Telephone LAmbert 4-7395

ADVERTISING

TELEVISION HORIZONS accepts commercial display advertising from bona fide manufacturers, distributors of electronics equipment and associated apparatus. Advertising rate card and coverage data available upon request.

CIRCULATION

TELEVISION HORIZONS is circulated through the mails on the 30th of each month to television rebroadcast and distribution systems, broadcasting personnel, television engineers and technicians, servicing and sales personnel and long-range television experimenters. Television Horizons is recognized as "the trade publication" of Cable TV, Translator TV, and fringe area TV engineers and technicians.

SUBSCRIPTION

Subscription rates in the United States, Canada—\$4.00 per year. Single copies not available. Subscriptions outside the U.S.A. and Canada—\$5.00 per year. Subscription remittances should be made by bank draft or postal money order.
Two year subscription rate U.S. and Canada—\$7.00. Three year subscription rate U.S. and Canada—\$10.00.
Airmail subscription available at \$7.00 per year, U.S. and Canada.

TABLE OF CONTENTS

TECHNICAL

STATE OF THE ART

"What the FCC Has Been Told About UHF" 5

"U" TO "V" SWITCH

"KFRE-TV Channel 12 to 30" 8

CABLE TV

"Maintaining CATV Line Levels" (part two) 12

TRANSLATOR TV

"Translator Transmitting Antennas" (part one) 12

PRODUCT REPORT

"Blonder Tongue AB-3 Amplifier" 17

LAB HORIZONS

"Field Tests of the Winegard Powertron" 26

GENERAL

OUR MAN IN WASHINGTON

"Interview with Commissioner Robert E. Lee" 3

UHF-TV

"True Confessions of a UHF Antenna Man" 14

DEPARTMENTS

CABLE DROP 11

TRANSLATOR TOPICS 28

UHF HORIZONS 32

FOR DXers ONLY 34

TELEVISION HORIZONS (title registered U.S. Post Office) entered as second-class postage material December 30, 1960. Second-class postage paid at Modesto, California. All rights reserved.

POSTMASTER: Send Form 3579 to Television Horizons, P. O. Box 3207, Modesto, California.

"Television Horizons' readers — always the first to know, the best informed, the first to act."

State of The Art

Exclusive Report . . .

What the FCC has been told about UHF

(Part Two)

IN REGARD TO RF AMPLIFIERS AT UHF

In the first installment of this exclusive report to the television industry, *Horizons Publications* detailed background for an FCC contract let to "Airborne Instruments Laboratory" of Deer Park, Long Island. Contract RC-9794 was devised to provide an "independent evaluation of receiving techniques suitable for UHF-TV reception." The Commission wanted to know what could be expected of the television receiving industry in the way of advancing receiver design in the coming five year period. In a step by step analysis "*Airborne Instruments Laboratory*" advised the seven Commissioners and the Commission's engineering staff of the "current state of the art" and what the future holds in store for improving UHF receiving techniques.

This second installment covers AIL comments on Junction Diode-Parametric amplifiers, Parametric Beam Tube amplifiers, Tunnel Diode amplifiers, Vacuum Tube amplifiers and Transistor amplifiers.

JUNCTION-DIODE PARAMETRIC AMPLIFIER

Quoting AIL's special report "The parametric amplifier is a device in which amplification is obtained through the mixing action of an incoming signal and a larger amplitude pump source, when both are applied to a non-linear reactance. The mixing action results in the production of harmonics and sum and difference tones of the signal and pump frequencies, which are also produced in a conventional non-linear mixer. However, where as a non-linear mixer absorbs power and therefore introduces noise without providing amplification, an ideal non-linear reactance acts as a lossless energy storage device that provides amplification while introducing very little noise."

"Among the factors inherent in the design of junction-diode parametric amplifiers the following are considered substantial enough to be beyond the scope of practical economic solution.

(1) *Conversion of the sum or difference frequency directly to the IF frequency.* The pump frequency and the local oscillator frequency must both be substantially higher than the conventional 45 mc. IF frequency. Frequency drift problems however might be solved by generating local oscillator frequencies by mixing a portion of the pump signal with a UHF source and then selecting the appropriate combination of these frequencies from the mixer output. Using this method frequency drifts in the pump source (the highest frequency involved, and therefore the least stable) will have a very small effect on the stability of the IF signal, whereas frequency drifts in the UHF source will be about the same as local-oscillator drifts in present converters."

(2) *Noise figure performance.* In this department the junction-diode parametric amplifier holds real possibilities. However, the methods necessary appear at this time to be very costly and unduly cumbersome. "The parametric amplifier must provide sufficient gain to overcome the noise contribution of the microwave mixer and IF amplifier. The characteristics of the best available microwave mixer diodes are such that the noise figure is essentially constant for frequencies up to 10,000 mc. It appears the optimum "sum frequency" is very close to 10,000 mc. Even with such a high sum frequency the maximum amplifier gain achievable in practice would vary from only about 9 db at a signal frequency of 890 mc. to about 11.5 db at a signal frequency of 470 mc. *The overall noise figure under such conditions would vary from only 2.8 db at 470 megacycles to 3.8 db at 890 megacycles!*

Unfortunately, all of this gain and lowering of the receiver noise figure is obtained at the expense of complex engineering and high quality components.

(3) *Negative resistance amplifier.* The junction-diode parametric amplifier is a negative resistance device. This means its overall unit stability is dependent upon absolutely

constant loading impedance as reflected at both the input and the output of the device. Thus the entire 470-890 mc. band must present a 100 percent flat impedance input to the amplifier throughout its range. Such antennas are unknown. However, the problem can be cured through the use of non-reciprocal transmission devices such as circulators and isolators, now used in microwave switching and antenna phasing units at frequencies to 16 kmc. These devices can also reduce the reflected signal level below that of the incident levels and are essential if stable and reliable operation is to be maintained in practical systems where both the antenna and receiver post impedances vary as functions of signal frequency and operating time.

At the present state of the ferrite art (*Note: ferrite is the material used in circulator construction*) suitable commercially available circulators cover bandwidths of only about ten percent of the UHF-TV band. Although it is expected that octave-wide circulators will soon be commercially available, their prices would prohibit them from being used in commercially produced TV receivers.

SUMMARY

Considering all of the foregoing factors, the negative resistance amplifier is not considered suitable for commercial TV use within the near future, even though it can produce excellent (laboratory) noise performance characteristics.

PARAMETRIC BEAM TUBES

In the parametric beam tube an electron beam is (1) passed through a "coupler" (i.e., mixer) where the noise signal present in the tube is removed during the "mixing operation" and replaced with a similar RF carrier carrying the RF input signal, (2) then passed through a quadripole structure where the "modulation peaks" on the RF carrier is increased by periodic pumping at a frequency above the signal frequency, and (3) finally passed through a second "coupler" where the amplified signal (i.e., original input signal placed on the RF carrier in action number one, plus the pumping amplified signal in action number two) is removed from the electron beam and delivered as a straight RF signal (amplified) at the output terminals of the unit.

In tubes of this kind available to date the pumping frequency is always delivered at a frequency approximately twice that of the incoming signal. Consequently the parametric beam amplifier tube has many of the properties of a conventional parametric amplifier.

In the "coupling action" two signals appear at the amplifier output terminals (i.e., at the signal frequency, and at the difference frequency between the pump and signal frequencies). The net result is an amplifier noise bandwidth that is twice as wide as the signal bandwidth.

Even though the original amplifier noise figure may be only 1.5 db at the low end of the UHF-TV band (470 mc.) the "twice bandwidth" parody adds an additional 3.0 db of noise to the output. Even this is reasonably good by present day standards, but the problems do not end here.

Consider two possible amplifier characteristics. First, assume that the amplifier pass band is wide enough to pass only the required signal and *difference frequency bandwidth*, and that this pass band can be tuned over the UHF-TV band. Assuming that a 15 mc. wide RF bandwidth is required for a TV signal, the amplifier pass band must be at least twice that wide to include the difference frequency bandwidth, or 30 mc. If the signal source is not perfectly matched over this 30 mc. bandwidth a portion of the original electron beam used to provide a carrier upon which the input signal is inserted (or modulated) will appear at the signal terminal and this will increase the amplifier noise figure. *It is not likely that the match will remain good, especially if the tuner must cover the entire UHF-TV band.*

The amplifier pass band can, in principle, be tuned solely by varying the pump frequency, by for UHF-TV use this would require ferrite circulators similar to those necessary in junction-diode parametric amplifiers. Here the same problem of obtaining a circulator which will cover the entire UHF band stymies the use of parametric beam tubes.

TUNNEL DIODE AMPLIFIER

"This device can be characterized as a one-port negative resistance amplifier in which the available power gain decreases and the minimum achievable noise figure increases with increasing frequency.

In other words, at any given frequency, the user has a choice of (1) gain, or (2) noise figure. The noise figure is low only when the gain is low. The noise figure then increases as the gain increases. Consequently for a given second-stage noise figure (i.e., stage following the first tunnel diode) there is an optimum tunnel diode amplifier gain that will produce the minimum overall receiver noise figure.

Assume the use of a typical commercially available tunnel diode, the 1N2939. Over the

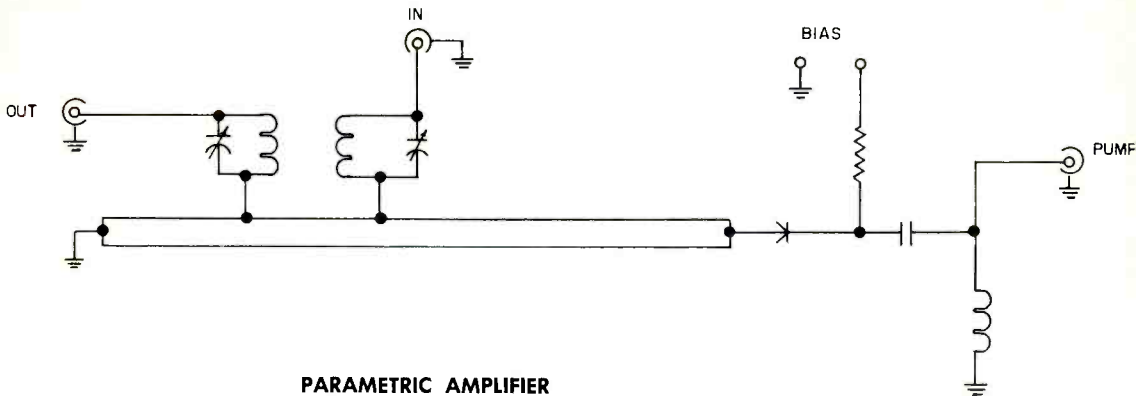

PARAMETRIC AMPLIFIER

The parametric amplifier obtains amplification through the "mixing" of an incoming signal (low amplitude) and a higher level "pump" signal. The pump signal is provided by an oscillator operating at a frequency three to ten times the frequency of the incoming signal. High isolation is required between the input and output circuits, and the pump oscillator. Very heavy shielding is used to keep all signal products of the pump signal oscillator EXCEPT the desired multiple out of the other stages. Each circuit is separately housed in "RF tight" boxes with coupling between stages limited to the transfer circuits.

UHF-TV band this diode will provide a gain in excess of 20 db with a noise figure below 3.4 db for a fixed amplification bandwidth of 15 mc. However, as with the tunnel diode mixer discussed in April, this device will have a small linear dynamic range. Furthermore as this device is a "one-port negative resistance amplifier" a non-reciprocal transmission network(s) must be used in conjunction with the input circuitry to minimize the reflected signal, maintain stability and keep impedances absolutely constant.

Due to these factors the future of the tunnel diode as an amplifier is not very bright at this time.

VACUUM TUBE AMPLIFIER

"Of the many devices (solid state and other) available for possible use as RF amplifiers in the UHF band, the vacuum tube in a grounded-grid triode configuration is possibly best suited at the "present state of the art."

For good UHF performance a high current density cathode and a very small (microscopic!) grid-cathode spacing are required. These factors tend to make the manufacturing tolerance for each such tube very rigid, and as a result their costs of manufacture rise proportionately.

The best commercially available triode is the 6280 which has a transconductance (G_m) of 50,000 microhms. Over the UHF-TV band this tube will provide a minimum noise figure varying from 4 to 6 db and a power gain averaging 20 db for a fixed amplification bandwidth of 15 mc. For such a large power gain, the noise figure contribution of a second stage

is negligible.

However, since the input bandwidth of a high transconductance grounded-grid triode is ordinarily quite large, a preselector must precede the amplifier to minimize undesired intermodulation effects. Assuming that a double-tuned preselector is used (found in current crystal mixer tuners) an insertion-addition of 2 db noise figure can be expected. This raises the overall noise figure of 4-6 db to 6-8 db.

There are other commercially available triodes on the market which might do an acceptable job on the low end of the UHF-TV band but their noise figures are questionable above approximately 700 megacycles. Among these are the GL6299, 7077 and 6BY4 ceramic triodes, the 7552 pencil triode, the 7586 nu-vistor triode and a 9-pin glass-enclosed A2521 triode manufactured in England and other European countries.

Taking the general performance of the above mentioned tubes into consideration, the use of commercially available triodes other than the 6280 does not appear justified since it would result in only a small noise-figure improvement over crystal mixers presently used for UHF-TV reception.

TRANSISTOR AMPLIFIER

"Transistors have achieved widespread general usage at lower frequencies because of their low power drain, small size and good reliability.

Transistor circuits tend to be come complex than those required for comparable vacuum-

(Continued on page 21)

KFRE-TV Voluntary Move to UHF

Commissioner Robert E. Lee's Private Preserve

For some years FCC Commissioner Robert E. Lee has been the leading exponent for the "ultra-high range" in Washington. Against odds which might have convinced lesser men the fight was useless, Commissioner Lee has fought continually for a nationwide competitive television system utilizing only channels 14 to 83.

The good commissioner's advances have sometimes been slow in coming and not always newsworthy. But like a good general he has continued to batter away at his enemy's weak spots and the enemy is now showing the first signs of faltering.

The Commissioner's approach is straight forward and his "foes" are seldom caught unaware, for Commissioner Lee does not rely on the element of surprise. Rather he attacks with "good old fashioned" common sense, tempered with an office bulging from ream upon ream of data which shows (by his way of thinking) UHF television coverage is every bit comparable to VHF, if both begin on an equal footing.

In recent months the Commissioner's efforts have been directed to the San Joaquin Valley of California where an inter-mixed VHF and UHF situation has existed since early in the mid 50's. Fresno and Bakersfield, California represent a pair of metropolitan areas each supporting six television stations. Of the six, four were UHF and a pair VHF. All six stations have network affiliation. The UHF stations are operating in the black although they have bucked the "V" competition to do so.

While working on one hand to strengthen fellow commission thinking about inter-mixed areas, Commissioner Lee worked on the UHF stations in Fresno and Bakersfield to gain support for his drive to remove the two VHF stations from the region. One year ago he was successful in Fresno and the commission ordered the move of KFRE-TV channel 12 to UHF channel 30. This move was completed on February 17 of this winter and the station is in the formal process of changing over to *complete* channel 30 operation as this is written.

This *Horizons Publications* report details the effectiveness of that changeover, plotting the measured channel 12 coverage versus the new channel 30 coverage. The success or failure of this "V" to "U" switch by KFRE-TV

will have a great deal to do with the future importance of the voice of Commissioner Robert E. Lee. If the changeover proves successful, the commissioner's persuasive powers with fellow commissioners (not all of whom *yet* favor UHF) will be strengthened. If the changeover is not successful, the Commissioner's fight for UHF could well suffer a set back of major proportions. Whatever the case, the "voluntary move to UHF" by KFRE-TV is of considerable national interest to the television reception industry.

TRIANGLE AND KFRE-TV

No one "who knows" is talking and those of us who don't know aren't too certain why Triangle Publications' KFRE-TV made the move from channel 12 to channel 30 without a fight. The station accepted the FCC announcement with no outward signs of remorse and in fact seemed to do everything possible to speed the transition.

The original "adjusted target date" for the changeover was January 6. However, the special design transmitting antenna (delivering 1.3 million watts ERP in the most favorable plane) was delayed at the manufacturer (RCA) and on the air tests did not begin until early February. At this writing KFRE is continuing operation on both channels 12 and 30 "to allow receiver adjustments to be completed." *The changeover from channel 12 to 30 has left some area without acceptable KFRE reception.* Without apparent exception the new shadow areas devoid of channel 30 signal are located within the foothills of the Sierra Nevada mountain range.

KFRE-TV is one of six television stations owned by *Triangle Publications*, publishers of TV Factbook, TV Guide and other periodicals. Of the six stations owned by Triangle, five (including KFRE) are VHF, and the sixth is UHF. KFRE's move to UHF is a smart move financially for Triangle. First of all it does not make the station any less valuable. A UHF high power dominant station *in an all UHF market* is just as valuable as a medium power VHF station in a "slightly VHF—mostly UHF" market.

Secondly it gives Triangle two UHF stations and four VHF. This leaves the door open for Triangle to shop around and find a new

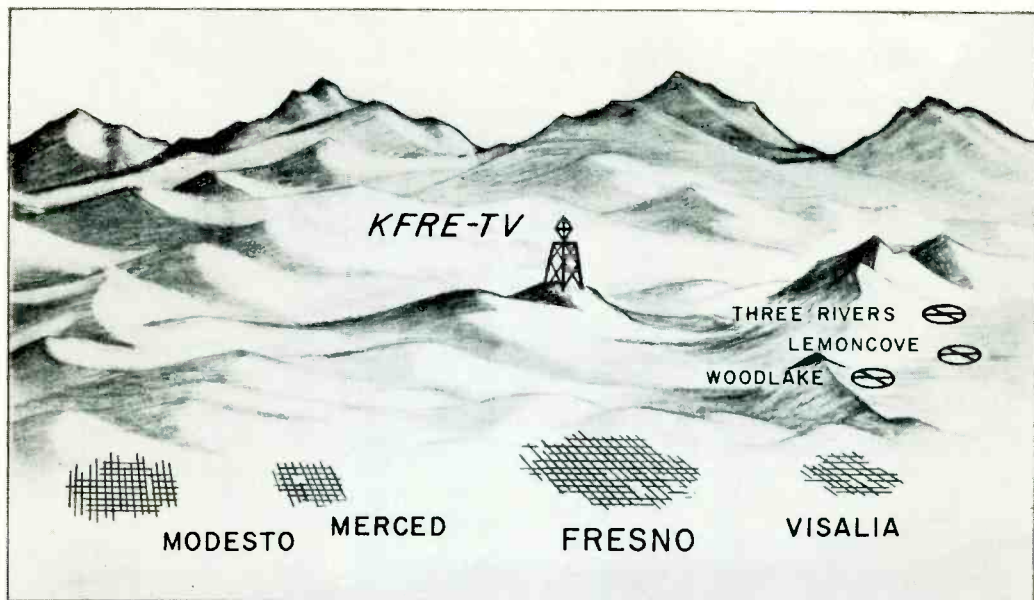

fifth VHF station, while at the same time holding on to their present valuable Fresno property. In other words, they haven't lost a son, they have gained a daughter!

COVERAGE

KFRE-TV is radiating more than 1.3 million watts maximum power. This is done from a mountain elevation some 2,000 plus feet above average terrain and nearly 4,300 feet above the floor of the San Joaquin Valley, which houses its principal market area. To the east of its Sierra mountain location the real mountains begin, rising up to elevations of 13,000 feet in a short distance. Few people live in this mountain wilderness, and fewer have television. Nonetheless there are TV viewers here . . . most of whom received only the KFRE-12 VHF signal.

To the south and north of the mountain transmitter site approximately 65 small "foothill communities" nestle within a 75 mile range of the transmitter (see *Cable Drop*, Story of Mariposa, California in the March *DXing Horizons*). Most of these towns received good signals from the KFRE channel 12 transmitter, few receive signals from the channel 30 signal.

However, the majority of these towns are close enough to the valley they receive other VHF signals from Sacramento and San Francisco area stations. Unlike the "deep Sierra towns" these foothill communities have not lost all television reception.

MARKET AREA COVERAGE

As the 71st market area in the United States,

Fresno, California has a metropolitan population of 370,000. It is served by two TV stations in addition to KFRE (KMJ-24 and KJEO-47). The value of a TV station in this valley area was made clear some weeks ago when a petition for sale was filed with the Commission by a broadcaster desiring to purchase KJEO-47. The announced price was \$3,000,000—the highest ever paid for a UHF station.

The TV market area includes more than 296,000 TV receivers. Fewer than 5,000 "more" exist in the Sierra foothills. The problem at KFRE these days is "how do we reach these 5,000 sets?"

TRANSLATORS, CABLES, et al.

Chief Engineer Keith Mealey has been exploring translators for some months. Once the actual channel 30 signal was on the air signal strength measurements went ahead. Several problems showed up during the testing period. The Adler antenna was not developing signal in the area south of Visalia, California (see map) and with Channel 29 in Bakersfield (KBAK) in the process of moving their transmitting antenna up by 6,800 feet (into the southern Sierras) KFRE engineers feared the southern San Joaquin Valley viewers would never find a "weak KFRE-30 signal next to a strong KBAK-29 signal." At the same time signal levels in the northern San Joaquin were fantastic! The antenna tilt was radiating a near optimum signal level into the entire northern valley as far north as Sacramento (165 miles.)

(Continued on page 36)

CABLE

DROP

Maintaining CATV Channel Levels Under Varying Conditions

By
W. J. ALBERSHEIM, *Vice President, Engineering,*
Spencer-Kennedy Labs, Boston, Massachusetts

Part 2. THERMAL REGULATIONS OF GAIN AND SLOPE

In part one of this discussion the author explained how the mean level and, if desired, the gain frequency response in broad band CATV transmission systems can be regulated through the use of automatic control stations.

Despite the reasons for gain control, it is not desirable to provide automatic gain control at every amplifier, for the following reasons:

1. ALC and ASC stations require at least twice as much equipment as straight-through amplifier stations.
2. Automatic control stations do not utilize the maximum capability of amplifiers because they provide a cushion for gain variations which may occur as tubes age, are replaced, or outside temperature and climate conditions vary.

Experience through the years has shown that it is a good conservative practice to space automatic control stations 3 to 5 amplifiers apart, corresponding to distance spreads of 3 to 5 miles.

In these intermediate spans amplifier input-output levels and level slopes fluctuate with cable temperature. As the signal moves to the last amplifier in the span before further ALC is added to the signal component, the amount of signal swing approaches the tolerance limits of the system. While a few db of variation may be less consequential near the first amplifier in the 3 to 5 mile span, it becomes very important near the last amplifier.

Thus "small" or slight variations normally attributed to outside climate or temperature variations become increasingly important. And the stability and quality of the signal transmis-

sion is improved if these temperature dependent fluctuations can be reduced.

SKL has accomplished this "temperature control" over the line levels by utilizing temperature sensitive passive elements known as Thermistors. The automatic reduction of temperature effects is called *Thermatic*.

THERMATIC GAIN REGULATION

SKL utilizes the fact that amplifier gain can be regulated by varying grid bias. As shown in figure 4a, grid bias is obtained from a voltage divider between fixed resistances and a thermistor. The gain temperature characteristics (figure 4b) is determined by appropriate balance between fixed and variable resistances. It is set to compensate for the thermal change in cable loss between amplifiers. By proper interconnections between the manual and thermatic controls the thermatic regulation range adjusts itself to the average amplifier gain.

THERMATIC SLOPE REGULATION

As mentioned in part one of this discussion, the frequency response of coaxial cables introduces a gain slope that is linear on a square-root-of-the-frequency scale. The average value of this slope can be compensated by fixed constant-impedance equalizers matched to a 75 ohm cable (such as the SKL types 444, 472, etc.).

To make the loss slope of these equalizers temperature-responsive, thermistors have been incorporated into the transmission network in such a manner that the impedance match is not noticeably impaired. Figure 5a shows the simplified schematic of such an equalizer. In hot weather the thermistors have less resistance and reduce the high frequency loss just enough to make up for the increased slope of the cable loss. Low frequency losses remain relatively unaffected by temperature. A typical family of loss curves measured at temperature intervals of 50 degrees F is shown in figure 5b.

SUMMARY

Long transmission systems containing many miles of cable and many cascaded wide band amplifiers are subject to large fluctuations of gain and gain slope.

Spencer Kennedy labs has attempted to meet these variations through (1) Automatic Control, described in the April issue, and (2) by forward acting thermal compensation, described in this concluding installment.

FIG. 4 THERMATIC GAIN REGULATION *

4a. SIMPLIFIED SCHEMATIC

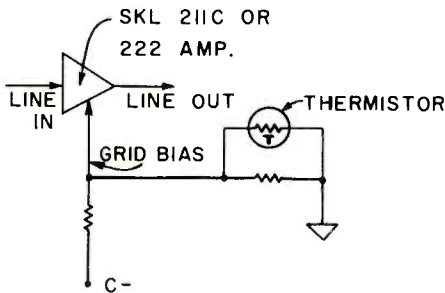

4b. TYPICAL THERMATIC GAIN RESPONSE

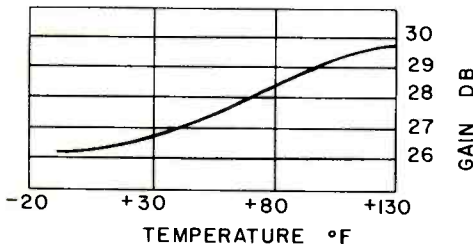

* PAT. PENDING

FIG. 5 THERMATIC SLOPE EQUALIZER

5a. SIMPLIFIED SCHEMATIC

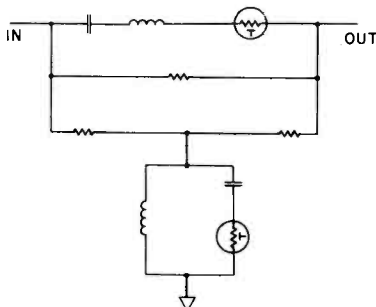

5b. TYPICAL THERMATIC SLOPE EQUALIZER RESPONSE

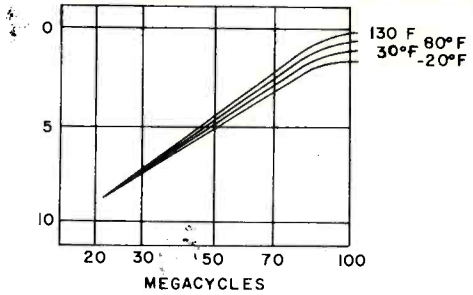

PACIFIC NORTHWEST MEETING

... We were there!

The Seattle meeting of the Cable TV operators of the Pacific Northwest provided Publisher Bob Cooper with an excellent opportunity to meet and talk with many of the nation's most talented and versed Cable TV constituents.

The meeting was well attended by more than 100 operators representing the states of Washington, Oregon, Idaho, Montana and Alaska. Also on hand were a number of manufacturers and distributors of Cable type equipment. Among those met were representatives from *Entron* (Bob McGeehan), *Jerrold*, *Ameco* (Ed Whitney and Pete Collins), *Blonder Tongue-Benco*, *Collins Radio*-Dallas, *Daniels and Associates* - Denver, *Mutual Electronic Supply*-Seattle and *Jack Pruzan Company*-Seattle.

Also on hand, although not as an official exhibitor, was Sid Wellum of Delta Electronics, Toronto, Canada. Wellum displayed a set of line and head-end amplifiers which drew considerable attention from cable operators who, for the most part, were hearing of the company for the first time.

Monday morning, April 17, the general business meeting got underway with President "Kirk" Kirkeeng of the *Columbia TV Service Company*, Kennewick, Washington wielding the gavel.

One of the early items on the meeting agenda was a series of reports from the various attending states on the subject of pending legislation as it affects the Cable TV world.

Ron Rue of Oregon noted that the recent Translator Tax District Bill pending in Oregon was defeated. However a follow-up bill is promised for the next session of the legislature. Rue also noted that the Cable TV System in Pendleton has taken over the operation of the local translator as a public service for the set owners outside the area of drops ("fringe

(Continued on page 22)

Translator Transmitting Antennas

Art W. Brothers
Associate Editor
Television Horizons

(Part One)

There are five different types of antennas used in Translator applications. These are the 2, 5 and 10 element yagi; the corner reflector and the rhombic. Various other types of yagis are used and have their place as do other antenna types which will be discussed in later articles.

Lay to rest one theory which has come down through the years and is now on its way out. That is that a good transmitting antenna makes a good receiving antenna. In translator work, this isn't so and both the transmitting antennas and receiving antennas must be designed for each specific site in mind. However, the main reason that the old theory doesn't hold water any more is that a good receiving antenna should not have an ability to receive the signal so much as it should have an ability to reject noise! If our antenna has a signal gain of just 5 db, but rejects 20 db more noise than a 10 db gain antenna right next door, it is plain to see that our 5 db gain antenna has, in actual fact, a 15 db higher gain figure than the second antenna. Gain to a receiver is not signal strength alone, it is the ability to deliver more signal than noise. Call it a figure of merit if you will, as receiving antennas will someday be designed for just that purpose and instead of db gain, they will be classified according to figure of merit—the ability to accept signal and reject noise.

YAGIS

Yagis are the most used antennas in translator work. The various types and typical patterns are shown below. The exact beamwidths must be secured from the manufacturer of a given array, however, the beamwidths shown will be considered to be approximate for both vertical and horizontal patterns of the antennas shown. (The patterns are approximate and are intended for illustration of principle only). These antennas may be stacked one on top of another, side by side, or combinations of both,

using up to eight sets of yagis with the 5 and 10 element antennas and up to 16 of the 2 element antennas. By altering the types and methods of stacking, the pattern from a given translator can be shaped to fit almost any community situation. This includes splits, triple splits, splits to obtain a long deep lobe, or a wide, but powerful lobe. Be wary of a 5 element beam with more than 11 db gain. In order to maintain a broad impedance bandwidth, a good TV antenna must sacrifice some gain in order to present a flat VSWR (Bandwidth) to the signal. Otherwise you will get distortion of the signal input or output and color translation will be poor. The same goes for 10 element yagis with boomlengths over one wavelength long. These antennas should have gains on the order of 12 to 15 db. The lower gain antenna might be best for a given installation, as its impedance band could be superior.

In case you want to check gain and beamwidth figures, the formula is simple. Gain as a ration of power is expressed as being equal to the half power beamwidths of both lobes multiplied together and divided into 30,000.

Power Ratio	db	Power Ratio	db
1.00	0	12.59	11
1.20	1	15.85	12
1.59	2	19.95	13
2.00	3	25.12	14
2.54	4	31.62	15
3.16	5	39.81	16
3.98	6	50.12	17
5.01	7	63.10	18
6.31	8	79.43	19
7.94	9	100.00	20
10.00	10		

Now, take the result and convert it into db by the above table. This is the gain according to accepted industry standards which assumes a 73 per cent antenna efficiency. If the manufacturer claims a gain of 1.2 db more than you calculate, this is OK. He is using a non-industry standard which assumes efficiency of 100 per cent. Advertising people use this figure to let the antenna show up better. This is why, when talking about antennas, you can figure any gain statement to be 1.5 db either way, as you are never sure which standard is being followed.

"If the gain of 10 element yagis isn't so superior to the 5 element, why use 10 element antennas at all?" This question is heard often and the answer is that the 10 element yagi generally is found in its superior rejection of

interference from other directions than that in which it is pointed. Also, some areas do not have tower room for more than one antenna, so maximum use must be made of existing gain on a single boom.

STACKING

Stacking any two antennas will cut the pattern of the plan in which the antennas are stacked, in half. If a pair of 5 element beams (with 10 db gain) are stacked one on top of each other, a half wave apart, the resultant would be a pattern 25 degrees wide in the vertical plane (pattern cut in half) which would double the power. Our antenna system (now 13 db) would have a horizontal pattern the same as it had before (50 degrees).

Compare this with a single 10 element yagi with a gain of 13 db. Its beamwidth might be in the order of 30 degrees in both patterns. The gain is the same, but the two 5 element antennas will give a much wider coverage to the community at less cost.

First pick the pattern which covers your area. Then stack until you have the desired gain. If your coverage area is a long narrow valley, stacking four 10 element antennas in a quad can give gains up to 20 db and a very tight pattern in both planes.

For receiving, a quad of 5 element yagis is better than two 10 element yagis. A quad of 10 element yagis is better than eight 5 element yagis if the gain is about the same. A single 10 element yagi is better than a pair of 5 element yagis. In all of the above, we have recommended the pattern which keeps the beamwidth down in both planes. With receiving antennas, this is important as you are interested in only one signal from a very well defined direction.

(To be continued)

Melpar to Install UHF in NYC

The Commission on April 10 signed a contract with *Melpar, Inc.* for the fabrication, installation and complete check-out of an antenna for the New York City FCC sponsored UHF test. The antenna, for channel 30, will be mounted on the Empire State Building.

Revised Form 347 Available

The FCC April 18 announced a new, revised form 347 (Application for a Translator Station) is available from the Commission or any of its field offices. Persons having old (July 1956) form 347s should destroy them.

DELTA of Canada announces the FIRST Complete Line of TRANSISTORIZED MAST MOUNTED TELEVISION AMPLIFIERS!

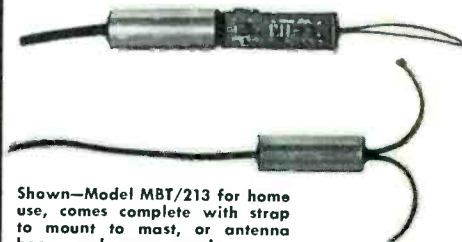

Shown—Model MBT/213 for home use, comes complete with strap to mount to mast, or antenna boom, and power supply.

LIST \$29.95

- *No Tubes to Replace!*
- *Constant Performance, no "aging" characteristics!*
- *Noise figure better than 6.0 db at channel 13 (Model MBT/213)!*
- *Gain 12 db or better on all VHF channels!*
- *Available for home use (300 ohm input-output)!*
- *Available for distribution systems (300 ohm input, 75 ohm output)!*
- *Single channel or broad band models — 2-6, 7-13, 2-13, single channel.*

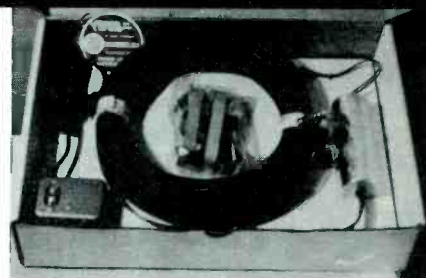

Shown—"Over the counter" Retailing Kit, includes attractive box with instructions, MBT/213 Transistor Amplifier, mounting hardware, remote power supply, stand-off insulators, 75 feet 300 ohm down-lead.

LIST \$39.95

Distributor Inquiries Invited

Write for full details today!

DELTA ELECTRONICS, Ltd.

QUEEN ELIZABETH WAY
CLARKSON, ONTARIO • CANADA
CR 8-5543

TRUE CONFESSIONS

OF A UHF ANTENNA MAN

Lee Thomas

M. H. Thomas Antenna Manufacturing Co.
Salem, Oregon

The installation of UHF antennas, especially in the Translator band (i.e., channels 70-83) has been a touchy subject for years. This is in part because it's a touchy job!

Many theories have been put forth on the subject and we all have uttered an unsavory remark or two. Some of us have even suspected the presence of gremlins.

But why not face the subject with a little reality? To begin with, it doesn't take a mathematician or a genius of any kind to be a good UHF installation man. You don't even need to be a good technician (although it helps). You do need a good set of eyes and an excellent memory. You don't even need expensive test equipment! You do need a fairly reliable inexpensive field strength meter and a well aligned properly operating test set.

Always remember that in this work a field strength meter is only a relative signal device. It won't take you long to learn what type of reading you need *on your meter* to register an acceptable picture at the set. Keep in mind you are not testing the receiving antenna for resonance and reactance, the famous db gain, lobe patterns or whatever.

YOU ARE MERELY LOOKING FOR A GOOD PICTURE!

A few examples to follow will give you some insight into the problems you can make for yourself by trying to be too technical or a "Johnny-know-it-all."

Since the advent of the first UHF channel in the United States (channel 27 in Portland) I have visited with many installation men in many-many different areas. Each community seems to present a different set of problems. Obviously, if you are working within one area, the first things to do is "get to know your own back yard." If you remember what you observe, and apply it in future installations, all of the outside "geniuses" in the world won't be able to compete with you.

Many problems will confront you, as well I know. Atmospheric density (a changing



"Get to know your own backyard."

"female" if ever there was one), foilage types and density, antenna salting conditions, saturating water condition (rain-rain go away, come again another day!), ice and snow, electrolytic conditions caused by various chemical conditions in the local atmosphere and terrain problems are but a few of the "local conditions" you will soon grow to "love!" As they vary and each will vary independent of the others, you will soon find *good judgment* is the very finest piece of "equipment" you have.

Let's talk about foilage density. We know it affects UHF. *The TASO report told us so.* Not that we needed to be told . . . any UHF antenna man could have saved them the trouble and expense of finding out for themselves! Learn what kind of foilage grows in your neighborhood. With your field strength meter in hand do a little "back yard probing." And if a customer's dog bites you on your first visit, you certainly know to watch more than the trees the next time you return!

What about salting conditions? You are placing installations near the Ocean and a continued fog builds up the saline compound on your feedline and antennas. Many commercial antenna manufacturers have devised "de-icers" but no one has a "de-salter" yet! *What to do?* The antenna should be as rugged as possible, and the transmission line should be double insulated to protect your picture. It may take you two return service calls, but you will soon learn that it takes "extra-precautions" in such areas.

A UHF signal is tested about 30 feet above ground for intensity. All conditions being right, you may have a good picture. But did you ever see a community with *all of their UHF antennas thirty feet above ground?* You learn after a while "the general heights" for signal in your area. But you also soon learn there are exceptions . . . sometimes more exceptions than general heights!

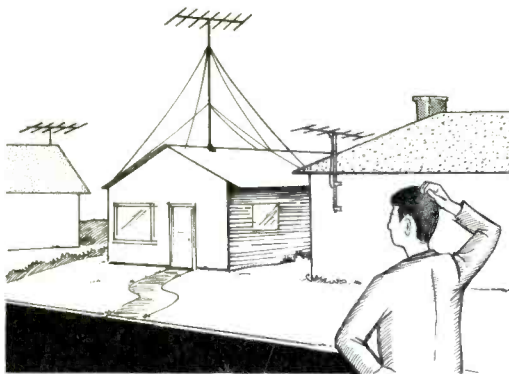

"Did you ever see a community with all its antennas 30 feet above the ground?"

Maybe you leave an open end on a hollow lead and water collects inside. You may not know *why* it shorts out the line and you lose the picture, but one thing is sure. *After a couple of free calls you will make different arrangements!*

If your lead-in line shorts out from resting on the damp ground or roof, and you gingerly pick it up to find the meter reading suddenly return to normal, you don't have to know why it does this. But you certainly learn soon it can't happen again and you make different arrangements in future installations.

When you fail to put a drip loop in the lead before entering a home and the water ruins "my ladyship's rug or floor" I hardly think you will repeat this procedure!

And you soon learn that switches, clothespins, poor splices, wrong wallthrus, the "long way around the room to the set," metal in contact with the transmission line, taping the lead-in line to the antenna mast, antenna or boom, ALL may be very convenient, *BUT certainly not good for the picture!*

Must you be a genius to learn these things?

I can hear the catcalls at this point! OK, so I have seen a customer's picture bad on channel 72 and good on channel 77. Against all of the textbooks' advice and even my better judgment I changed the 6AF4. Out came a better picture on channel 72 and no change on 77! Let's let the tube manufacturers worry about these things, I won't.

I have seen pictures on UHF only six feet above ground and 100 feet away, the set owner had to go to 40 feet to get any signal. But why worry about it? It only happens once in (you name it) times.

I have seen a picture at a point where the signal comes directly across water all the way (the text books tell us this is an "ideal situa-

tion"). Along the edge of the water I have measured signal levels that fluctuated from 100 uV to 700 uV at the very same antenna terminals. 200 feet away and still at the edge of the water, the signal was rock solid at 500 uV. They tell me over water signal transmission is perfect and very stable. *I agree!* And I'm sure not going to tear my hair out trying to re-write the text books.

In erecting Translator transmitting antennas I have seen a 200 foot wide strip develop where the *line-of-sight signal level* is considerably down from the surrounding areas. Using a two-way communications system I tried raising and lowering the transmitting antenna hoping to eliminate the dead spot. I tried three different models of transmitting antennas. And I tried skewing the polarization of all of the antennas. Vertical . . . horizontal . . . even in between! *Nothing worked.* I know it can't happen, so I walk down the street talking to myself.

One time I decided to get away from it all. I started on a fishing trip, going across one of



"He couldn't get any channel 6."

the passes to Eastern Oregon. While crossing the pass I noticed a ranch house a short distance from the road on the "far side of the summit" from channel 27 in Portland. The ranch house was in a small opening surrounded by tall pines stretching up 75 to 100 feet. *But behold!* On a 15 foot mast leaning against the ranch house I spied a 24-element channel 27 colinear! At this time channel 6 was also operating out of Portland. No channel 6 antenna was in evidence. After ten minutes of driving my curiosity got the better of me and I simply knew this man couldn't be getting channel 27! I turned the car around and returned where the rancher showed me his channel 27 picture. Admittedly it wasn't much, but the rancher quickly informed me *he couldn't get ANY channel 6!*

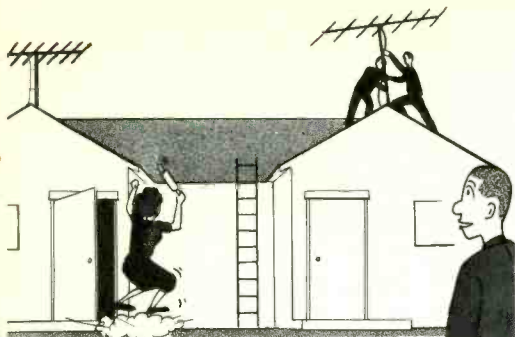

"The lady was screaming cops."

Knowing this couldn't be true I left in haste believing more than ever in "TV gremlins." to this day I haven't returned although I pass the ranch house often. Now I just look the other way and don't even slow down!

One day while calling on a good friend in the TV business he suggested that I go with him on a replacement job. It was an easy reception area and we knew we would have an opportunity to visit. The old weather-beaten installation displayed a fairly good picture. And try as we might we had nothing but trouble with the new installation. We fought with the installation for two hours to finally discover that the manufacturer of the hollow tubular line had forgotten to copper coat six feet of the steel core transmission line. So even manufacturers make mistakes!

A local dealer called one day to ask my help. eH had just installed an antenna 50 feet up at a duplex. The new antennas was at the same height as an existing installation 60 feet away and between it and the station. The lady who lived in the "far side" of the duplex was screaming for the "cops" because (she said) the installation man had stolen her picture! She insisted her TV picture disappeared when my local dealer installed his new antenna array. Needless to say I told my local dealer friend that the "lady" needed some work on her set (and maybe her head). At "her" insistence I watched her set while the antenna installation crew patiently lowered down the new antenna. *Wonder of wonders!* Her picture returned! We pushed the new array back up... and her picture disappeared again. Finally we offset the new array by ten feet and everyone was happy. And I returned to the plant wondering why I have only one life to live!

On another occasion a Cable TV operator called for aid on his channel 27 antenna instal-

lation. When I arrived he patiently explained he had "cross-sectioned" the area and was at a loss to know why a single folded dipole was "showing" as good as stacked yagis, colinears, or anything else he tried! Of course, I didn't want to insult the man, so while I remained non-committal he proceeded to show me a pretty good picture from the dipole.

Still remaining non-committal I took my antennas from the car and with murder in my heart, planned my attack. I suspected I had been called on a long trip by a *yokel* that had no business *being in business* if he was *that* stupid. I chased my feet all day long until they were flat. My patience was worn to a frazzle... and I hadn't done one uV better than his dipole! I finally bowed out as the sun set over the hill apologizing to the *gentleman* "I guess I'm not so smart after all." I was confused... *and I still am!*

So I must confess that while I use good sound technical information, charts and formulas upon formulas in following my work, I have found it necessary to modify the use of this data to varying degrees to meet the idiosyncratic of each community and each installation.

Universal rules, as far as this UHF Antenna man is concerned, have not yet been written. *And I suspect they never will be!*

KFRE-TV Gets 60 Day Dual Permit

The FCC has granted a continuation of operation on channels 12 and 30 for KFRE-TV Fresno, California until June 1, 1961, while KFRE-TV is installing UHF and VHF translators to fill in coverage areas not currently covered by channel 30, but which were previously covered by channel 12.

FM/Q

ANTENNAE SYSTEMS

GET MORE FM STATIONS WITH THE WORLD'S MOST POWERFUL FM BROADBAND ANTENNAE

To be fully informed, send 30¢ for NEW Edition of "All About FM Antennae and Their Installations" by I.F.B. Carini. Contains Directory of FM Stations and Log.

FM/Q WETHERSFIELD 9, CONN.

TVH Reports

Blonder Tongue

Mast Mounting

AB-3

Amplifier

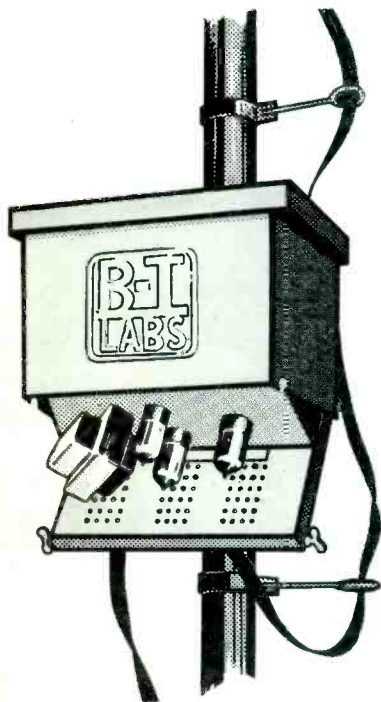

BLONDER TONGUE AB-3 antenna mounting broadband TV-FM pre-amp.

BLONDER TONGUE AB-3

The B-T antenna mounting pre-amplifier is the latest in a series of high gain-low noise units designed to give the signal an *added boost* before it is corrupted by passing autos, local atmospheric static and radiation noise from nearby dust covered AC power lines.

Like the previous models in many lines Blonder Tongue has attempted to build maxi-

imum gain, lowest noise figure and high reliability into the antenna top unit. B-T takes advantage of the low-noise high-gain characteristics of the popular 6DJ8/EC88 triode (similar to the 6922) in the front end (RF section). This is followed up by a pair of 6EW6s.

Blonder Tongue has long been an advocate of "dual output impedance terminals" and this unit is no exception. Actually B-T recommends the use of 75 ohm coaxial cable with the installation for reasons to be pointed out shortly.

The AB-3 consists of a single "flip down chassis" weatherproof box, mounting as close as possible to the antenna (see illustration) and a remote power unit which goes at the receiver or inside the home. The remote power supply unit (model RP-3 shown) feeds A.C. power to the antenna top amplifier through the 300 ohm down lead or the coaxial cable feed line. The AC voltage is isolated from the actual antenna through a network mounted at the amplifier, and from the set by an isolation transformer mounted within the power supply, before the signal tap-off is made to the receiver.

Blonder Tongue pays particular attention to the installation personnel's selection of a feedline, and with due cause. While B-T is anxious for the amplifier to deliver the best possible signal to the receiver below, they are also concerned for the "loop resistance" the feedline will present to the power going *up* the line. Each amplifier is packed with a chart listing 15 different types of feedlines (coaxial, flat and tubular twin line, open wire, etc.) which in turn tells the installer how much voltage loss he can expect per 100 feet of feedline. This chart in turn works into a "variable voltage tap" on the power supply which allows the user to compensate for resistance loss in the feedline. 6DJ8 operation is most efficient within a fairly narrow range of voltages, which happily coincides with the tube's most favorable operating condition voltages (ie., best longevity span, etc.). Wishing to keep the user from frequent trips to the top of the antenna for swapping tubes, the voltage selection taps are indeed a necessity.

GAIN

Model AB-3 antenna-mounted TV/FM amplifier is designed to cover channels 2-6, 7-13 and the FM broadcast range from 88 to 108 megacycles. B-T specifies 22 db gain *minimum* over any portion of this range.

(Continued on page 20)

NOW...A Complete Line of

Built-in Amplifier clears up snow, improves

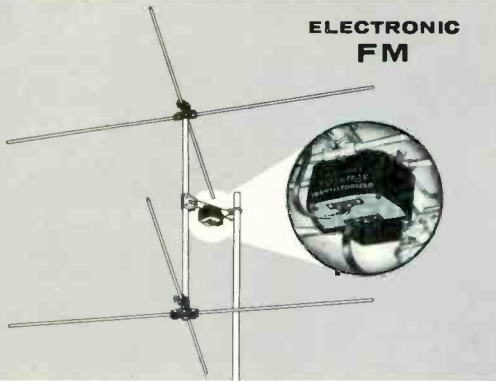

**ELECTRONIC
FM**

MODEL PF-T FM POWERTRON TURNSTILE Non-directional FM antenna with 16 DB gain in all directions over a folded dipole. Has unique offset mount and comes complete with built-in transistorized amplifier and TV-FM coupler.

NEW, POWERFUL TRANSISTORIZED FM POWERTRONS WITH FM-TV COUPLERS

For the first time, FM antennas with built-in transistorized amplifiers are available for long range FM reception. Winegard offers two models—FM Powertron Turnstile (omni-directional) and the FM Powertron Yagi (directional). Both models have two 300 ohm terminals on the amplifier: one for down-lead connection to the set and one for connection to a TV Powertron antenna.

MODEL PF-8 FM POWERTRON YAGI This is the world's most powerful FM antenna. Makes weak signals come in like "locals". Has 25 DB gain over folded dipole. Eight elements with exclusive Winegard "tapered T" driven element. Built-in TV-FM coupler allows you to couple into TV Powertron with only one power supply. Complete with built-in transistorized amplifier.

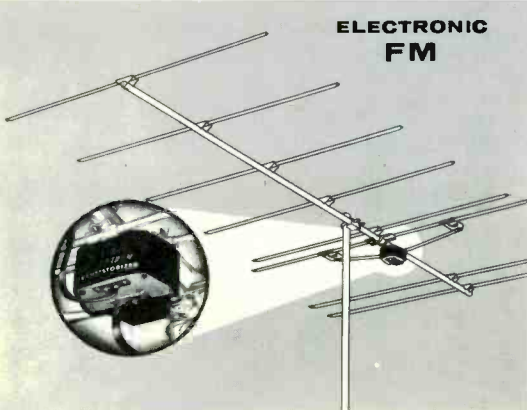

**ELECTRONIC
FM**

In addition to three all-channel (VHF) Powertron antennas, Winegard now offers you 14 cut-channel and broad band Powertron yagis and two FM Powertrons. Each of these high gain antennas has the following important features:

1. Electronic amplifier for unprecedented antenna gain.
2. Amplifier connected *directly* to the yagi "Tapered-T" driven elements for best possible signal-to-noise ratio.
3. Linear frequency response for crisp, clear black and white and brilliant, true color reception.

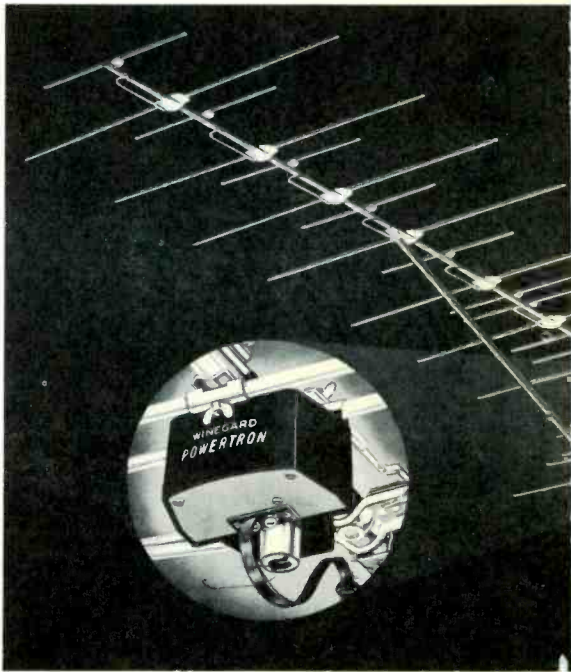

ELECTRONIC ALL-CHANNEL YAGIS

... will greatly improve every channel. Weak, faded pictures become crisp and clear. "Good" channels will be even better. In many areas you'll watch channels you couldn't possibly see before. Because Powertrons are powerful enough to drive up to 10 TV sets, you can have plug-in outlets in every room ... and in many locations you can install a Powertron lower than other antennas.

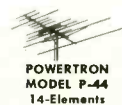

**POWERTRON
MODEL P-44**
14-Elements



**POWERTRON
MODEL P-44X**
21-Elements



**POWERTRON
MODEL SP-44X**
30-Elements

Winegard Electronic Antennas

contrast... gives you greater reception distance!

4. Gold Anodized finish for permanent corrosion protection and fine appearance.

5. Deluxe quality materials and workmanship.

Try a Powertron and see for yourself. Take a field strength meter reading with your present antenna and then take a Powertron reading. When you see the meter jump 5 to 10 times . . . and see the sharp, contrasty reception you get, you'll be convinced . . . and so will your customers.

**"Amplifies the Signal
at the point
of Interception"**

MODEL SP-44X

"By FAR world's most powerful all-channel antenna"

**WINEGARD "SIX-SET"
TV COUPLER**

With the Powertron, hook up 3, 4, 5, or 6 sets by adding a Winegard "Six-Set". Here's the only 6 tap coupler on the market. Six no-strip terminals give you instantaneous taps with complete electronic isolation. Model LS-63.

©1961

**THE
"SIX-SET"**

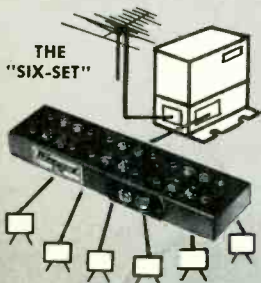

**ELECTRONIC
Cut-Channel
TV**

Each channel
amplified
individually.
No antenna couplers
needed!

NEW, TRANSISTORIZED CUT-CHANNEL YAGI POWERTRONS FOR THE FINEST INSTALLATIONS

Here are the highest gain (28 db) TV antennas ever made! Each is powered by a built-in transistorized amplifier. Because TV signals are amplified right at the point of interception, you get the best possible signal-to-noise ratio . . . resulting in the ultimate in reception!

Each Powertron yagi amplifier has two 75 ohm coaxial connectors: one for the down-lead to the power supply and one from the built-in coupler for connection to another Powertron yagi.

Because of the built-in mixing coupler, they can be connected directly to each other without interaction. The negligible power consumption of these transistorized antennas (.05 watt each) means you can tie as many as 8 Powertron yagis together and run them all from one power supply on one down-lead.

There are six (8-element) cut-channel and broad low band models—eight (12-element) cut-channel and broad high band models. Ideal for hotels, motels, apartment buildings or wherever the finest installation is needed.



Winegard
ANTENNA SYSTEMS

Winegard Co., 3000 Kirkwood St., Burlington, Iowa

Write today for technical bulletin on Winegard's complete line of Powertron antennas. Ask your distributor for details.

BLOCK DIAGRAM

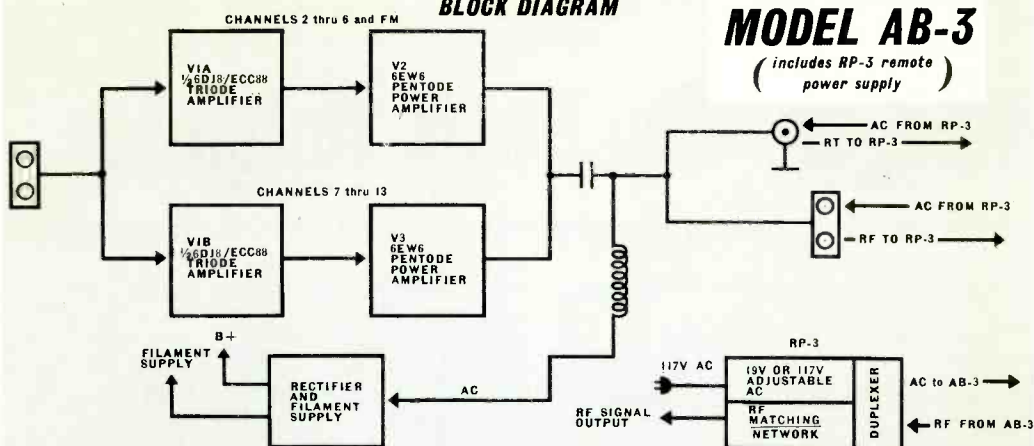

MODEL AB-3

(includes RP-3 remote power supply)

AB-3 AMPLIFIER

(Continued from page 17)

OPERATION

The AB-3 amplifier is mounted to the antenna mast or tower at the antenna. In the case rotor installations the unit should mount below the rotor box. The selected type of transmission line is run from protected terminals on the underside of the mast-mounting box to the remote power supply unit, mounted at the receiver. A short length of transmission line connects the "output" terminal on the remote power supply unit to the receiver. And a like length of 300 ohm line or 75 ohm coaxial cable feeds the amplifier from the antenna.

GOOD ADVICE INDEED!

B-T also advises the use of coaxial cable. We can see a minimum of two solid reasons for this approach. *Number one* is the shielding coaxial cable affords the amplified signal from outside ignition, electrical motors, etc. interference. *Number two* is the obvious hazard of running 19 volts AC up an open wire (or twin lead) transmission line.

Our test model withstood considerable knocking about not normally encountered in more "safe and sane" operation. This included an 80 feet drop to ground level when the tower decided to come tumbling down one Saturday afternoon (see story "How to Make Insurance Companies Enjoy Paying for Antenna Towers!" in an upcoming issue)!

To our surprise the AB-3 still perked along on its single cylinder following the "sky-to-and 7-13. A remotely switched relay selects the input yagis as we switch channels in the lab.

For future reference (in "Our Lab Reports") Modesto's off-the-air reception is unique. No

broadcast station is closer than 60 airline miles, while the limit to groundwave reception is but 240 miles away. A minimum of one station is available on each channel, in 360 degree antenna headings. Five UHF channels are available at distances from 78 to 232 miles. Average daily microvolt readings run as low as 10 on VHF to 5 on UHF. Maximum include 32,000 on VHF and 10,500 on UHF. The extreme range of signal levels (on interference-free channels) and wide selection of beam headings makes our off-air lab ideally suited for equipment testing under conditions varied enough to equal any likely to be found in North America.

IMPRESSIONS

We were particularly impressed with the AB-3's ability to clean up snow on channels 7-13. Our channel 7-13 antenna consists of a pair of 12 element yagis stagger tuned to cover the range.

Microvolt readings in the 40-70 uV range showed good increases in contrast level when the amplifier was switched at the antenna. Signals in the 10-30 uV range went from barely watchable to "comfortable viewing quality" and color confetti on a pair of marginal color channels disappeared completely.

Most of this we attribute to the obvious good taste in using the 6DJ8 series tube in the amplifier first stage.

Our unit was in the air seven weeks before the fateful March 25 tumble to the ground. Total clocked operating time was 490 hours. There has been a constant rumor about of late that 6DJ8 series tubes perk along very well earth plummet."

For testing purposes the AB-3 was fed al-

ternately with long-john yagis for channels 2-6 for the first 500 hours, and then take a sudden dip which may last for as long as 250 hours. This (the rumor has it) is followed by a gradual recovery period during which time the tube comes back to almost original quality. It may last 4,000-10,000 hours with good quality high-gain results after the recovery period is completed. Unfortunately our test period did not clock 500 hours, so we cannot verify the validity of the rumor at this time. Taking cognizance of this rumor, Blonder-Tongue reports that they have made extensive tests on a large number of 64J8 tubes and noticed no dip at all.

OUR SUGGESTION FOR IMPROVEMENT

As will be the custom with "Our Lab Reports" the Horizon's engineering staff makes a few notes on overall unit usefulness and recommends a modification or two.

In the case of the AB-3 our recommendation is for an improvement of the straps (a pair) which mount the amplifier to the tower or mast.

The straps use a heavy "set screw" to force the return edge of the mount to the leading edge. Quite frankly we found the mount incapable of holding the AB-3 *as tight as we would like to see it*. Under severe wind conditions we suspect the straps would slip and the amplifier turn. Under such conditions a taut feedline *might* pull loose from the input or output mounting blocks.

Our suggestion is a good old fashioned "U-bolt" similar to the mounting configuration found in the CDR-AR 22 rotor series.

Next month Horizons Publications checks a popular Jerrold antenna mounting pre-amplifier.

HORIZONS PUBLICATIONS' AMPLIFIER CHECK LIST

	EXCELLENT	GOOD	FAIR	POOR
Noise Figure	✓			
Gain	✓			
Color Performance	✓			
Construction		✓		
Apparent Reliability		✓		
Physical Mounting Ease				✓

WHAT THE FCC HAS BEEN TOLD

(Continued from page 7)

tube devices because of the internal feedback present.

To reduce parasitic problems and thereby move the useful range of transistors into the UHF-TV band, coaxially encapsulated devices are becoming available.

Personnel at *Bell Telephone Laboratories* have produced a coaxial-transistor designated the M2107 which, when properly used, provides a nearly constant gain up to 750 mc. This amplifier has a 50 ohm input and is capable of delivering a 1 milliwatt output into a 50 ohm output (load). The measured noise figure is somewhat higher than 5.5 db at 200 mc. and is believed to remain constant up to about 700 mc.

Philco has announced the L-5431 coaxial transistor which they claim provides a power gain of 8 db at 1000 mc. and about 14 db at 500 mc. The noise figure claimed for this unit is 4 db at 200 mc. and is believed to remain fairly constant to 1000 mc.

Taking into account the rapid strides in transistor circuitry and solid state design in the past decade, it appears the transistor will provide god noise figure performance in the UHF-TV band consistent with adequate bandwidth and stable operation. When such devices become commercially available they will probably be used in UHF-TV receivers, provided they remain competitively priced as with lower frequency units. Since the fabrication of these transistors is suitable for production line techniques, this seems a reasonable assumption."

END OF QUOTE

A good portion of this report and that noted in the April installment, has been taken from the text of FCC contract number RC-9794 as prepared for the Commission by *Airborne Instruments Laboratory*.

In June this special report to the television receiving industry will conclude with a survey of industry reaction to the report, to UHF in general, and an exclusive look at UHF laboratory receiving devices now under consideration across the country.

-R.B.C.

CABLE DROP

(Continued from page 11)

region"). Rue also urged that the Cable TV Association in the northwest make a study of the translator situation with an eye towards working *with*, not *against* such operations.

Also reporting, from Idaho, *Harley Steiner*, and for Montana, *Fred Plummer*. *Cliff Collins* wrapped up the session with an analysis of pending and future cable and translator legislation.

Monday at noon the general business section broke up for a luncheon. During the course of the luncheon President Bill Dalton of the *National Community Television Association* presented plaques honoring past presidents of



CABLE TV OPERATORS ALL—A portion of the crowd in the exhibit hall at the Seattle CATV meet. See anyone you know?

the *Pacific Northwest Cable TV Association*, to *Harley E. Steiner*, Vice President and Manager of *Pacific Northwest TV* (Idaho), *G. L. Lew Davenport*, of the *Dalles TV Company* (Oregon), *Carroll D. Courtmier* of *Pendleton Community Television* (Oregon), and *Charles Clements*, currently the secretary of the NCTA. The current President of the PNW-CTA, *Kirk Kirkeeng*, took the occasion to announce his "retirement" in line with recent acceptance of the post of Public Relations and Promotion Manager for AMECO, Phoenix, Arizona. *Kirkeeng* was also presented with a beautiful plaque honoring his service to the Northwest Cable TV operators.

Prior to the presentations, Monday, *Publisher Cooper* addressed the group on the topic "*Can CATV Meet the Threat of Competition?*" The talk themed around the use of cable systems as a focal point of local civic activities. *Cooper* noted that several progressive CATV operators have begun to investigate the use of the wired system for *local origination*.

Cooper noted "... While in the east I saw one very excellent example of a CATV system operator who feels that his system should be more than merely an extension of the custo-



FIVE PROUD EX-PRESIDENTS! Left to right, ex-prexys *Kirkeeng*, *Clements*, NCTA President *William Dalton*, and more ex's—*Courtmier*, *Davenport* and *Steiner*. Each displays his plaque for outstanding service in the Cable TV industry.

mer's television set. This man believes that if his cable system is to survive and to continue to show a healthy rate of growth, it must become an integral part of the community." Closed circuit local TV, *Cooper* noted, is the very best tool available to accomplish this means.

NAB DEFINES CATV OPPOSITION

... Letter to Chairman *Minow*

In a letter dated April 6 *National Association of Broadcasters'* President *Leroy Collins* told FCC Chairman *Newton Minow* "... After several weeks of careful re-examination of the NAB position and analysis of arguments (relative to the proposed Senate Bill 1044) advanced by CATV proponents, we have concluded that interests not only of the public but also of broadcasters will be served best by enactment of legislation along the lines pro-

(Continued on page 24)

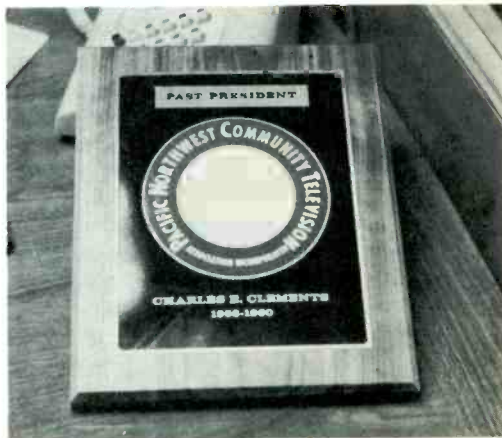

CHARLIE'S PLAQUE—Close-up of the beautiful engraved plaque awarded to *Charles E. Clements*, *Waterville, Washington* in recognition for his service to the PNW-CTA in the years 1958-1960.

HORIZONS UNLIMITED*

CATV BUYERS

CATV OWNERS

You Reach the Widest Range of Prospects through

DANIELS & ASSOCIATES, Inc.

PIONEER CATV BROKERS

EXCLUSIVE CATV BROKERS

BUYERS

- Let us show you investments with three to five years short term complete return of capital.
- Move now to be on the ground floor of the expanding future in CABLE TELEVISION.
- Check with Daniels & Associates, Inc. for precise appraisals of existing systems.
- Let us outline an investment program in the field of CABLE TELEVISION.
- Management is no problem with the Daniels & Associates, Inc.'s proven system of personnel selection and recommendation.

OWNERS

- Capital gains is frequently your best answer to depreciation problems. Let us show you why!
- To realize the most profitable return for your CABLE TELEVISION investment you must reach the broadest possible market with your sales intent message.
- Before selling or establishing a price, obtain an accurate appraisal of your system from our independent experts.
- OUR JOB . . . to locate buyers of competent ability and financial responsibility.

For discreet representation, sound advice and quick results—contact the ONLY CATV authority recognized throughout the United States and Canada. More than 90% of all CATV system sales to date have been handled by Daniels & Associates, Inc.

DANIELS & ASSOCIATES, Inc.

BILL DANIELS CARL WILLIAMS ALAN HARMON FRED METCALF
The Daniels Building, 3rd Avenue and Milwaukee, Denver 6, Colo., Dudley 8-5888
Canadian Headquarters — — — 31 Quebec Street, Guelph, Ontario, TAYLOR 2-2030

**PROGRESSIVE BROADCASTERS alert to the natural expansion of their present interests are contacting Daniels & Associates, Inc. for information regarding CATV opportunities in their immediate coverage areas.*

CABLE DROP

(Continued from page 22)

posed by the Federal Communications Commission in Senate Bill 1044.

"NAB does not advocate government regulation merely for the sake of regulation.

"But, as broadcasters committed not only by law but by conviction to serve the public interest, we recognize there are instances where the public interest . . . which must be the overriding consideration of us all . . . requires the protection of governmental regulation soundly predicated.

"In our opinion the type of legislation proposed by the FCC regarding CATV systems falls in this category . . ."

NCTA REBUTTAL

. . . Letter from Dalton to the Press

With the April 6 letter of NAB President Collins circulated, NCTA wheels were churning to answer the NAB position (which had been long expected incidentally).

In replying to the "open letter," President Bill Dalton noted ". . . I have a great deal of respect for the NAB, for the association's board of directors, and for President Collins and his staff. I also respect their views and their careful judgment, as do members of NCTA.

"In this case, however, it is difficult for us to understand why NAB is encouraging legislation, the very concepts of which are not in keeping with our traditions of free enterprise."

Dalton noted that in years past it might be understandable that the NAB would promote legislation to "regulate" the CATV operator. Now however, noted Dalton, the proper disposition of broadcaster-CATV conflicts is found at the conference table.

Dalton concluded with ". . . I expect all thoughtful broadcasters, network executives and CATV operators would be jointly concerned over the prospects of legislation that



DELTA ELECTRONICS, Toronto was represented by Sid Wellum, President of the Toronto firm. Here Wellum checks over the company's single channel high band amplifier, reportedly capable of 70 db gain!

could usurp the management function and might lead to limitations on the public's privilege of TV program selection."

KIRKEENG MOVES TO AMECO

. . . PR and Promotion

Courtney M. Kirkeeng, prominent CATV systems executive from the Pacific Northwest has been named Public Relations and Promotion Manager for *Antennavision, Inc.*, according to Bruce Merrill, President of the Phoenix, Arizona firm.

Antennavision currently operates 21 CATV systems serving 11,000 homes in California and Arizona, and is in the process of construction with five additional systems in the Imperial Valley of California.

Kirkeeng has been extremely active in the *Pacific Northwest Cable TV Association*, and is currently serving as President of the Association.

Kirkeeng will join Antennavision (AMECO) on June 15, just prior to the National CATV convention in San Francisco, June 20-23.

THREE SYSTEM SALES REPORTED

. . . Daniels Strikes Again

Daniels & Associates, Denver, Colorado, pioneer in the CATV management and brokerage field reports the sale of three CATV systems to the *National Theatre Company*. Systems sold to the chain include Hattiesburg, Mississippi, and Ferriday, Louisiana (formerly owned by *Spencer Kennedy Labs*) and Man-Logan, West Virginia. The three systems represent 7,500 subscribers, and increases the NT & T holdings to 20,500 subscribers across the nation.



DALTON SPEAKS—Kirk Kirkeeng listens during the April 18 session in the Hotel Olympic, Seattle. Dalton commended the Pacific NW group for their continued leadership and foresight in the CATV industry.

**to take advantage
of the best
signal-to-noise ratio ...
mast mount this amplifier**



AB-3

**to use ac power source
up to 1 mile
from the antenna...
plug in this
remote power supply**



RP-3

NEW BLONDER-TONGUE MODEL AB-3

mast-mounted TV/FM amplifier with remote power supply

New engineering features incorporated in the Blonder-Tongue model AB-3 mast-mounted amplifier make it possible to utilize the maximum signal-to-noise ratio available at the antenna, and at the same time, power the amplifier from an AC source up to one mile away. Whether you use the AB-3 and its remote control power supply (RP-3) in a fringe area home installation, or as a pre-amplifier in a master TV system—by locating the amplifier close to the antenna, you take advantage of the best available signal with noise picked up by the down lead minimized.

The remote power supply sends AC power up to the mast mounted amplifier on the same down-lead that carries the antenna signal down. What's more, the remote power supply provides the correct power to the amplifier for any length of connecting cable up to one mile (when open twin-lead is used.) The RP-3 also serves to isolate the antenna signal from the AC and to provide an excellent impedance match for either 75 ohm or 300 ohm cable. This new amplifier employing a low noise frame-grid tube provides 22db (almost 13X) gain on VHF-TV and FM stations.

other features include:

MAINTENANCE FREE OPERATION — Matched remote power supply provides correct voltage for any length of down-lead, assuring longer tube-life.

EASY INSTALLATION WITH 300 OHM TWINLEAD OR 75 OHM COAX—Stripless terminals for 300 ohm twinlead; solderless "quick-disconnect" terminals for 75 ohm coax. No balun is needed because the input is matched to 300 ohm antennas.

CHOICE OF MANUAL OR AUTOMATIC OFF/ON SWITCH — Turns AB-3 on and off automatically when used with most TV sets.

Model AB-3 (including RP-3 remote power supply) \$104.50.

Available through distributors.

Free System Layout Aid Available For Master System Installations. Write Dept. HC.

engineered and manufactured by

BLONDER-TONGUE

9 Alling St., Newark, N. J.

Canadian Div.: Benco Television Assoc., Ltd., Toronto, Ont. Export: Morhan Export Corp., New York 13, N. Y.
home TV Accessories • UHF converters • master TV systems • FM-AM radios

LAB HORIZONS

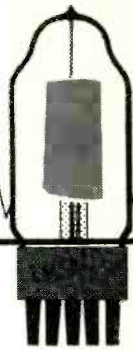

FIELD RESULTS —

WINEGARD POWERTRON

As reported in the February issue of *DXing Horizons* the Winegard entry into the “electronics end” of this business arrived in the form of an antenna-mounted broad-band amplifier. Winegard had begun gearing for this entry more than a year ago with a token output of 6DJ8/6922 broad-band set couplers and splitters.

When the first announcement of the Powertron was made there were many skeptics. There undoubtedly still are a few around.

Horizons Publications has completed a series of extensive checks with antenna installers from Maine to Oregon and points between to ascertain how well the Powertron is performing in the field.

We are grateful to the Winegard Company for their aid in preparing this material. It is hoped it will be of sufficient scope and depth to aid you, as an antenna installer, in future and present Powertron installations.

POWERTRON OSCILLATION

Horizons Publications, in checking across the country, learned of a few installations where the 6DJ8 antenna-mounted amplifier appeared to be oscillating on “randomly-selected” channels. The oscillation problems reported did not appear to follow a pattern so we checked with President John Winegard who told us “One case where the installer had trouble with oscillating was traced to his mounting an FM antenna slightly below the Powertron, and running two lead-in wires very close together down the mast and into a common feed-through bushing through the wall of the house. The oscillation occurred because the amplified signal in the output of the Powertron was being capacitively coupled to the FM lead-in wire where it traveled back up to the FM antenna, reradiating back to

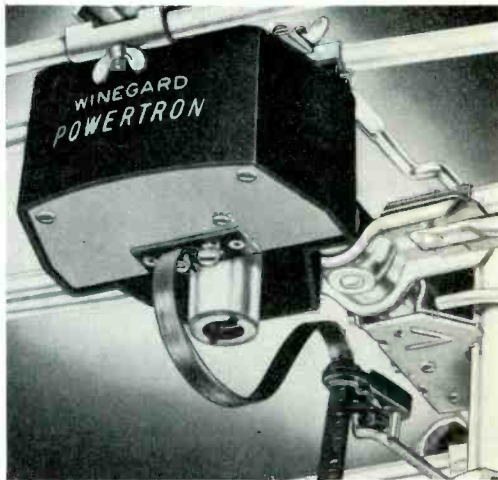

POWERTRON CLOSE-UP shows correct method of running lead-in down wire away from amplifier.

the Powertron! This caused a feedback loop, and the resulting oscillations.

After the dealer rerouted the FM lead-in on the other side of the mast and fed the FM wire through a separate feed-through bushing, the oscillations were completely eliminated. This particular case of oscillation occurred on channel 6.

A separate case of oscillation tracked down by the *Horizons Publications* reporter was traced to a similar FM antenna installation which was side-mounted to a self-supporting tower 15 feet below the Powertron. A common feed-through bushing was used to enter the house. In this case the oscillation appeared to be on channels 12 and 13, although it occasionally jumped to channel 3!

A case of high band oscillation reported to Winegard was traced down in this fashion. “. . . the dealer installed a rain loop in the down lead of the Powertron as he brought the amplifier away from the amplifier. He looped this wire over the front driven element before running it down the mast, and the coupling

between the lead-in wire and the front driven element was sufficient to cause oscillations on the high band. Again, rerouting the lead-in wire so it dropped straight away from the amplifier down the pole completely eliminated the trouble."

WIPING

Because the Powertron is a broad-band amplifier, the input circuitry accepts all signals on the TV band. If the Powertron is mounted too close to a high-powered TV station where the field strength is 100,000 microvolts per meter or more users may experience severe cross-modulation showing up as a windshield wiper effect on other (weaker) channels. This same effect would (and does) occur with any mast-mounted amplifier unless a trap for this particular (strong-local) channel is installed *ahead* of the amplifier.

John Winegard reported to *Horizons* "We have field tested the Powertron in cities where there are several high-powered stations, and pulled in distant fringe stations without cross-modulation." *This is not to say, however, that it cannot occur.*

POWERTRON MODIFICATION

There have been two modifications in the Powertron antenna from the original "first-production" series.

The first is the inclusion of an 1800 ohm static discharge resistor from the antenna input coil to the chassis. This resistor is to leak off static charges accumulating on the antenna via the lead-in wire.

The second modification involves the power unit which mounts set-side. The original units were provided with two voltage taps, 24 and 28 volts. The current production run unit is provided with three taps of 22, 26 and 28 volts. It was found in some areas the AC line power from the house was higher "than normal" which could possibly shorten the life of the 6DJ8/6922 amplifier tube. Thus the 22 volt power tap. All units now leaving the factory are set for 22 volts. The Powertron will work normally as long as the supply voltage at the amplifier is between 20 and 24 volts.

Wisconsin TV Channel Changes

The FCC has finalized its rule making — looking towards the allocations shifting in Richland Center and Madison, Wisconsin. Channel 15, previously in Richland Center, has been moved to Madison. WMTV-33, Madison will move to channel 15.

DX-ing HORIZONS
recommends

Amperex[®]
Ampliframe
FRAME-GRID TUBES

for
**MAXIMUM
TV DX**

As reported in the July, 1960 issue of DXH: "... Greatly improved audio ..." "... Video lock-in range extended ... to nearly 300 miles ..." "... Identifiable audio with any signal that barely comes into sync ..."

These gain-improvement advantages are the result of IF and tuner conversion with these Amperex Ampliframe tubes ... 6EH7/EF183 • 6EJ7/EF184 • 6922/E88CC • 6DJ8/ECC88 • 6ES8 • 4EJ7/YF184 ... available at your local radio parts and ham distributor.

ask Amperex
about AMPLIFRAME tubes
for DX applications

Amperex ELECTRONIC CORPORATION
230 Duffy Avenue, Hicksville, L. I., N. Y.

TRANSLATOR

Prepared monthly by
James Beamer*
P. O. Box 833
Livingston, Montana

TOPICS

THE FCC

*... Overworked, Understaffed, and
In The Dark*

Monday morning, April 10, Publisher Bob Cooper popped in on Allen Cordon and Harold Kelly in their FCC offices in Washington, D.C. The arrival was not announced, no meetings had been scheduled. Cordon and Kelly (as most readers are aware) are responsible for translator applications processing and engineering approval, respectively. Cordon's office seemed anything but a flurry of activity. But it didn't take him long to direct us "down the hall a piece" to the processing and receiving room where the staggering work load of VHF translator applications has been ever on the increase. Here we found a half dozen clerical employees literally "up to their necks" with applications from translator enthusiasts around the nation. Just that morning, we were told, 222 applications had been delivered to the work room by the friendly mailman. This room was a flurry of activity. Stored in boxes (see photo) were more than 550 VHF translator applications of FCC form 346. Between 50 and 100 were arriving daily. Said Cordon "if we don't get some help down here pretty soon we may be processing these applications through next Christmas." He may have been kidding, but he certainly was not boasting.

The work ahead (we could readily see) is monumental. Cordon and Kelly have spent long, hard hours trying to convince Commission superiors that "there ought to be a simpler way of processing the applications." To date they have had only minimal results.

Cordon does report that a new modified and slightly undated version of form 347 (application for a license) has been cleared by the application planning staff, but it will help little. And certainly it will be nothing to shorten up the existing problem . . . processing form 346s.

In addition to the recent heavy influx of form 346s (Cordon told us "It is taking us as long to process a form 346 for a translator sta-

*Secretary, National TV Repeater Association, Tri-State Repeater Association.

tion as a full-fledged application for a one million watt TV broadcasting station") a goodly number must be returned to the applicants for further work, or corrections. Approximately forty per cent of those received daily meet this fate.

For the benefit of the translator industry, Cordon listed these specific points which he notes "are most responsible for the returning of 346s."

- (1) Not notarized, or improperly notarized.
- (2) Exhibits accompanying the application dated AFTER the date of notarization. The exhibits should be dated for the same date as the notary seal.
- (3) Only one set of exhibits included in the application (three should be filed).
- (4) Inconsistency in the name of the translator applicant. As an example, if the name of an individual is John J. Smith, Jr., the signature must be John J. Smith, Jr., not John Smith, or John Smith, Jr. If the TV association is known as the *Squaw Butte TV Association*, the application should read throughout in just this way, not (for example) *Squaw Butte Television Association* on one line and *Squaw Butte TV Association* on another line.

Take it from your publisher, the Broadcast Application Bureau is NOT having an easy time of it with translator applications. We suggest you adjust yourselves to a minimum of ninety days before expecting action on your license application, once you have been notified it has been accepted.

NO SPECIFIC HOLD-UP IN 346 GRANTS ... Just Routine?

Rumors were frequent and consistent during April that the Commission was sitting on form 346s. This is partly true . . . but not entirely so. If the FCC has been sitting on applications, it is in most part due to the fact that they have run out of room for storage!

In a more serious vein, the Commission has in truth held up action on many applications for a number of reasons. First of all, many of

(Continued on page 30)

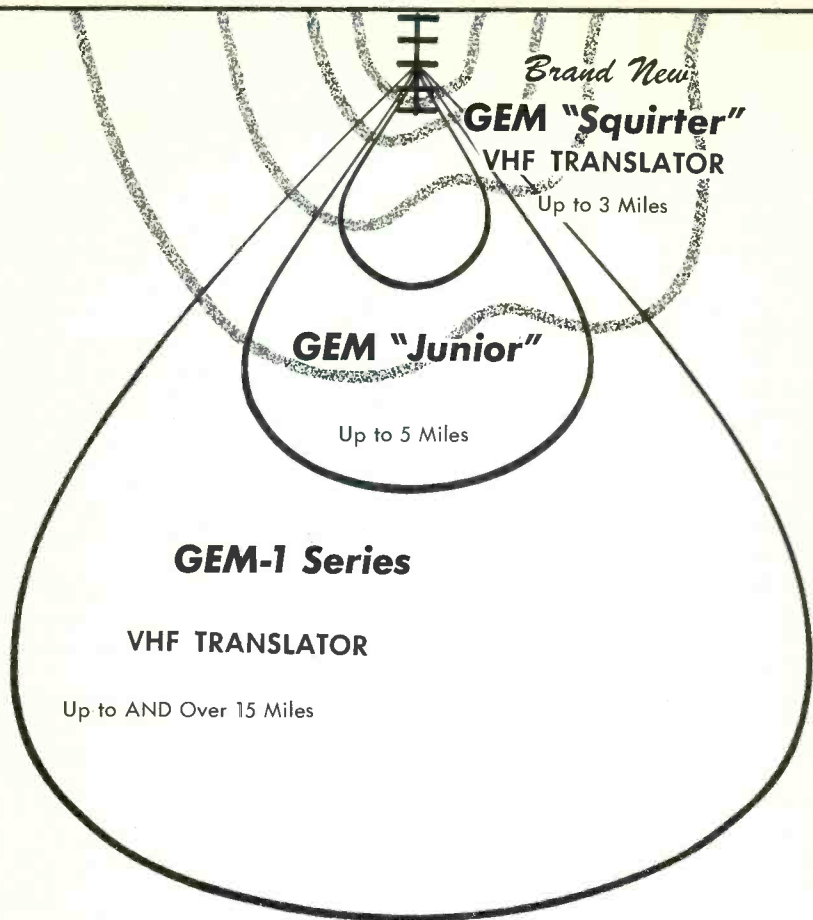

Another First from GEM!

BUY ONLY THE SIGNAL YOU NEED—with GEM's range of three VHF Translators —

- (1) Determine the coverage area you wish to cover.
- (2) Check the GEM "LOBE COVERAGE CHART" above.
- (3) **THEN** — Choose from one of the following proven GEM units:
 - GEM Squirter**—perfect coverage to 3 miles*—ONLY \$650
 - GEM Junior**—perfect coverage to 5 miles*—ONLY \$775
 - GEM-1 Series**—perfect coverage to and beyond 15 miles*—ONLY \$995

*With suitable transmitting antennas

Every GEM VHF Translator is available with fail-safe Radio Remote Control at a cost of only \$100.00 extra.

YOUR GEM-1 VHF TRANSLATOR IS FULLY GUARANTEED
Satisfaction or your money back!

GENERAL ELECTRONIC MANUFACTURING, INC. (GEM)
 POST OFFICE BOX 865 • ROSEBURG, OREGON

GEM, Inc.—From the Land Where People Know Translators Best... The Pacific Northwest

TRANSLATOR TOPICS

(Continued from page 28)

the applications are unusual for one reason or another. Among these we find—

- (1) Applications from broadcasters desirous of extending THEIR signal coverage area into regions covered by OTHER stations.
- (2) Applications from VHF translator enthusiasts in UHF areas, either broadcaster or UHF translators.
- (3) Applications which pose unusual technical problems.

The Commission apparently feels considerable study must be given to the applications now ready for processing. Unofficial word is that when the study is completed and a decision reached in each of these categories, the big backlog of applications will begin to move. With decisions made, one applicant from each category can be passed upon, and it will in turn set a precedent for all of those to follow. The hold-up to date has been due to the study involved, and once the decision is reached and an application processed, the precedent will be set. And that precedent will determine the action for all like applications to follow.

Some breakthrough in this backlog is expected around May 15 and applications should flow through the Commission in greater speed after that date.

TWO ADDITIONAL TYPE ACCEPTANCES GRANTED

The FCC has announced type acceptance on the Telson Electronics Company TE-1A and Eitel Electronics VHF-TR10/1 VHF translators. This brings to five the number of VHF translators type accepted. Previous acceptance had been given the EMCEE HRV-1, MARS RX-17B and BENCO-BT T-1.

BRAND NEW UNIT FROM BENCO

... One watt, around \$700.00

While in Toronto during April TVH Publisher Bob Cooper learned of a new VHF translator unit from Benco Ltd. Tagged the T6, the new VHF rebroadcasting unit will operate with one watt output through a new Amperex tube, the 6939 . . . a dual tetrode. Specifications for the T6 were forwarded to the FCC in Washington during early April. According to Benco President Phil Freen the T6 will have no voltage regulation (internally), simpler AGC, and will mount on a metal plate suitable for inside mounting. These changes from the T-1 unit, although slight, are sufficient to bring

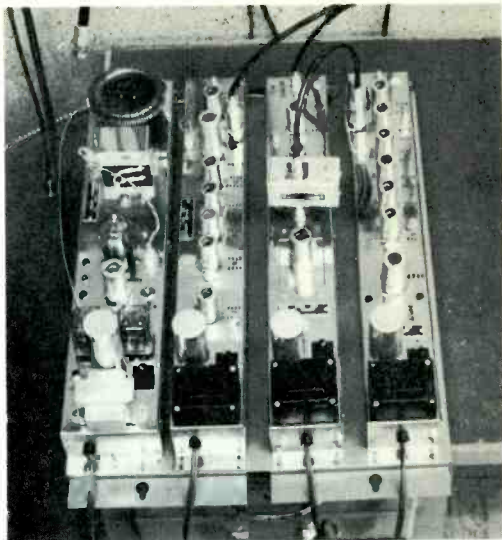

BRAND NEW FROM BENCO—The T6 one watt VHF Translator was shown Publisher Bob Cooper while he toured the Toronto plant. Unit is a complete VHF Translator, minus cabinet. It will be available in the states through Blonder Tongue.

the price down to "around or below \$700.00" according to Benco. The T6 will be available through Blonder Tongue in the United States.

NEW FORM 347

... Simpler and Shorter

Word from the Commission indicates a new revised form 347 (application for a translator license) will be out soon. The new form will be only slightly changed from the current form. An advance release of the form will be reviewed in an early *Television Horizons*.



HELP! Boxes upon boxes upon boxes . . . and then the mailman arrived with 271 additional applications (form 346) Monday, April 10. The young lady was (quite understandably) "all shook up!"

PROBLEMS WE GOT!!!

At the Salt Lake Western Translator Conference Publisher Bob Cooper gave evidence the number of translators could grow in five years from the present 1,184 to 10,000.

This startling figure of 10,000 was kicked

around by all concerned in the bull sessions Friday night and in individual groups all day Saturday; the consensus of opinion of those in the know agrees with the figure.

This provocative figure prompted your editor to inquire of a later meeting on March 4 just how many translator clubs knew of other translator operations around their perimeter. The sad fact was no one indicated they had any knowledge of what is going on 15, 20, 45 miles away.

Now comes some real soul searching on the part of the clubs. What are you going to do? Wishfully hope that interference never raises its ugly head and wipes out the television in your community. This can happen with only 12 channels to work from, and translators being sold like hot cakes. *What assurances do you have this will not happen?*

No one but no one is going to examine interference problems for us. *The FCC says its our baby.* If we interfere with each other, don't cry on the FCC shoulders. We are forced to adjust the problem ourselves.

Here is what *mush be done.* Each state must have first as a basic function, a state organization and as an appendage, a coordination control system within each state organization. *This*

would consist of an area director who would cover a portion of the state readily accessible to him; a State Coordinator to examine problems on a state level; and a National Coordinator to examine and oversee all activities on a national scale.

The progress of an application of an individual club in any state for clearance of the use of a particular channel would follow in this order. (1) The applicant club would file with the District Coordinator an application for a particular channel. The District Coordinator would examine the application, pass on it, and forward the application to the state level where it would again be examined by interference; finally the application would be sent to the National Coordinator where a final examination will be completed. If approved at all levels from the applicant upward, the individual club will be notified and the channel requested by the club will be reserved for them in their area.

The state organizations are getting material ready to mail to their respective clubs on this plan. Do not fail them in their efforts. Please read and fill in the information sheets for them. This will be your assurance of continued interference-free television. —J.B.

SITCO

Heavy Duty Quads and Yagis



Write for Free 1961 SITCO Catalog

Designed by SITCO for Translator off-the-air pickup, Community TV and extreme fringe area requirements.

The SITCO Models 94 and 102 Quad Mount Antenna Arrays are designed to produce high gain, high front-to-back ratio and large aperture to weak signals. A completely balanced system which reduces noise pick-up and greatly improves the signal-to-noise ratio.

NOW, all SITCO element ends are machined to reduce static leakage. The signal-to-noise ratio is increased at sites where signal levels are low.

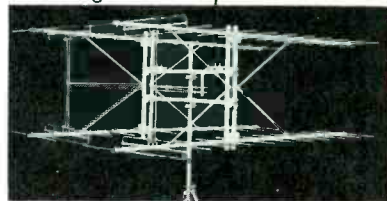

Model No. 102-HD 48-element Quad



Model No. 94-HD 32-element Quad

SIMPLICITY TOOL COMPANY

2850 NORTH MISSISSIPPI • PORTLAND 12, OREGON

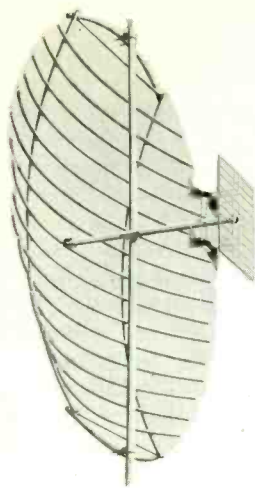

UHF HORIZONS

Conducted Monthly by
Harlow Speckhart
Route 1, Box 317
La Grande, Oregon

"News of the UHF Translator World"

BROADCASTERS AND TRANSLATORS ... *New Formula Evolving?*

An embryo idea about to hatch in the Pacific Northwest may have repercussions across the United States as large broadcasting firms evolve plans to assist outlying UHF Translator operations to provide a top-quality picture to the rural viewing public.

So bold is the approach and so sound does it appear on the surface, it is likely to set the stage for similar activity outside the Pacific Northwest.

In instances where the UHF Translator operation covers a sufficient volume of homes the commercial broadcasters are proposing to take over the operation of the repeater stations rebroadcasting their programs.

Under the plan the FCC license and the operational cost of the Translator will also be taken over by the broadcaster. And any CATV system or "repeating Translator" would of course be welcome to use the signal. Broadcasters are also proposing to act in an advisory capacity to assist the small shadow areas with their technical problems.

The broadcaster's interest in the expansion of outlying coverage apparently stems from a recently completed survey of the "natural trade areas" in and near large metropolitan regions where the broadcasters are located. The survey revealed that in many regions the "natural trade areas for large metropolitan markets" extends beyond the coverage of that center's telecasting stations. The translator device would appear to be an obvious means of extending the telecast signal to *all of that natural trade area.*

If an engineering study now under way proves this approach to be economically sound, translator television will witness sudden influx by the broadcasters themselves as they strive to "completely cover" the natural trading circumference.

In past years the "state-of-the-art" of measuring "trade areas" has been limited by the range of the telecaster's signals. Under the new findings, the trade area (which the telecaster must strive to cover) actually extends beyond this magic electronic limit. *The translator is the answer.*

PROPOSAL

The proposal is to use 100 watt UHF translators to provide local coverage at the relay points and a dish antenna using part of this 100 watt power to provide "a relay link" to the next 100 watt translator in the system.

The entire network would be maintained and operated by the origination telecaster as assurance that the quality of the signal at the "end of the line" would be equal to the signal quality at the "head of the system."

Broadcasters exploring this plan in the Northwest have stated they are in a position to invest \$1.00 per viewer home to assist the local residents in providing *high quality signals to existing translators and cable systems* they plan to cover as a part of the overall program. It is contemplated that existing UHF translators will be used where feasible to aid in the relay system.

On the planning boards it appears one of these "Translator networks" will increase the existing station coverage area by over 100,000 viewers.

In the final analysis the proposed network would encompass all of the actual marketing or trade area.

In one sense the telecaster's existing signal has been the determining factor in measuring what actually constitutes a "trade area." However, as our country has grown, so has the extent of the so-called trade areas. Now the telecaster is thinking in terms of providing "trade area coverage" to his advertisers, as opposed to the more commonly measured "marketing area" which consists (in the final analogy) of only that region covered by the existing station's direct signal.

Forward thinking telecasters in the northwest deserve recognition for what will undoubtedly become a nationwide approach to television coverage. And it would seem that the entire program is building towards the day when all television moves to UHF and the

local "translator" or "satellite station" becomes an ever increasing important part of this nation's television allocations and coverage picture.

ON-CHANNEL UHF BOOSTERS

In January of 1961 the Federal Communications Commission proposed to authorize on-channel UHF signal boosters for translator operations (docket No. 13924). This was explored previously by *Horizons* (see At-Sign Off, January

1961). The Commission now proposes to authorize the "multiple" linear amplifiers permitted by the FCC. The amplifier unit would be used on one channel (i.e., 75), properly amplified and then rebroadcast it on another channel it was picked up from the original station identification of the translator. It would be required although the translator could be turned down (turn off) when the signal leaves the air.

The Commission felt (and apparently still does) that low-power boosters could be used to fill in shaded areas which are not in the field coverage pattern of the translator.

At the cost of such a unit is apparently low to allow as few as five homes to purchase and operate it. Apparently the commission is convinced "On-Channel Boosters" are technically feasible even for high power broadcasters, as a pair have been authorized for broadcaster use since this past October (see November 1960 and March 1961 *DXing Horizons*).

Considerable interest in the subject of "low-power" boosters was uncovered during the "Western Translator Conference" in Salt Lake City. Your editor found numerous operators in attendance who felt the unit, if properly manufactured could be a real boon to existing shadow region coverage problems.

The "Western Translator Conference" will no doubt go down in history as a real asset to the growth of the translator industry. It provided an excellent opportunity for the translator operators, who are for the most part laymen and technicians of limited experience, to exchange ideas with professional engineers and broadcasters. Those translator operators who did not attend (whether VHF or UHF) should by all means make definite plans for 1962!

(Continued on page 36)

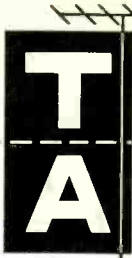

Thomas Antennas

UHF-VHF Transmitting and Receiving

The World's Finest TRANSMITTING AND RECEIVING ARRAYS!

Registered with the FCC

- TRANSMITTING ARRAYS
- RECEIVING ARRAYS
- FRINGE AREA TRANSMITTING AND RECEIVING INSTALLATIONS (a specialty)
- COAX HARNESSSES DESIGNED AND CONSTRUCTED FOR CUSTOM INSTALLATIONS
- "TRANSLATOR QUEEN"—*The only ruggedized UHF translator home receiving antenna*
 - 16 Element Rear End Suspension, Channels 70-83
 - 28 Element Center Suspension, Channels 70-83

Thomas UHF transmitting arrays are guaranteed to produce the finest pictures obtainable. A pioneer in the television "difficult reception" field, M. H. Thomas is in a position to make this outstanding guarantee!

An M. H. THOMAS antenna will provide the finest picture possible. Period!

M. H. THOMAS ANTENNA MANUFACTURERS

2862 HIGH STREET, S.E. • SALEM, OREGON
Telephone EMpire 4-8901 or EMpire 3-5058

For DXers Only

(TV and FM long distance reception enthusiasts are invited to participate in this column by submitting long range reception reports, AND, practical long range reception hints concerning equipment and DXing techniques. Reports to appear in the June Television Horizons should be in prior to May 14.)

ANTENNAS

Some like 'em big... and some like 'em small.

It seems to run in cycles. *Losing towers we mean.* First TVH Eastern Lab Director Jim Gould reported his carefully constructed 65 foot high lab receiving array a victim of ice and wind (April DXH).

Now, less than thirty days later, the same fate has befallen the western lab antenna in Modesto.



STEEL TOWER all over and through the roof line in Modesto! In the foreground, the smashed mid-section of the 120 footer. In the background the upright but smashed 80 footer with "totaled" low-high and FM yagis.

It was not a pretty sight. We were in the process of raising to 120 feet a new experimental all-channel "electronic antenna" for the TV range. The 120 foot tower was properly mounted on a concrete base, heavily strapped to the building and seemingly in fine shape. Less than twenty feet away our trusty eighty foot crank up was doing its duty supporting several low and high band yagis, as it had for nearly eight years. The 120 foot crank up was nearing the 115 foot point, almost at the spot where the guys would take hold. There was a slight breeze at ground level. **AND THEN IT HAPPENED.** A gust of wind, a resounding crack and shouts as tower workmen ran for cover! *The all steel tower began to topple towards the southeast, directly towards the eighty footer!*

A quick thinking workman dug in his heels and attempted to hold the 120 foot steel monster but he was too late. For his gallant efforts he was dragged forty feet across a cement walk and slammed against the building. The 120 footer toppled into the 80 foot array and the two intertwined, crashed and crumbled through the redwood roof tearing out an array of communications antennas and our six foot Channel Master Para-Scope for UHF. In less than ten seconds eight cumulative years of back-breaking antenna work was smashed beyond belief.

Not a single antenna... *not even reference dipoles or shortwave long wires...* was left standing.

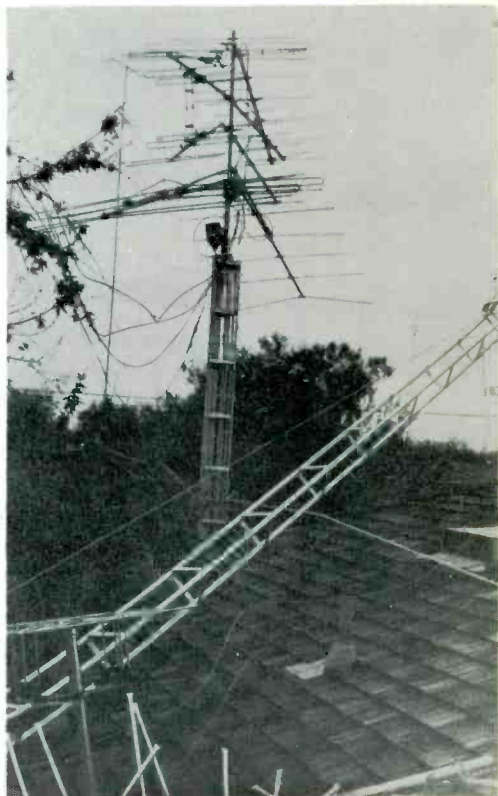

SMASHED YAGIS and cracked steel tower (in the background) were constant reminders of the dangers in 100 foot and up crank-up towers. *Our advise—"when using crank-ups, stick to the 80 foot and down variety!"*

Needless to say the lab schedule has been set back a few weeks... perhaps months. Amplifiers and antennas to be tested are piling up, but we hope to have new towers (a pair of eighty footers this time... *no more 100 or 120 foot monsters!*) in the air shortly after this is read.

P.S.—Perhaps you don't believe in gremlins. We didn't either. But this entire episode happened on April 1 . . . *April Fools Day!*

ANOTHER ANTENNA

Canadians are a hearty lot. *And they build the darndest antennas!* Ernest V. Blair of Chapleau, Ontario, Canada is even heartier than most. Blair builds antennas . . . and they are apparently some of the most effective on the North American continent.

The photo below is Blair's channel 4 long-long yagi, 29 feet 4 inches in length, 140 pounds heavy. The number of elements in line . . . 20!

This monster array gives Blair 125-200 microvolts on channel 4 from WTOM in Cheboygan, Michigan . . . a distance of 118 miles. The huge antenna is 100 feet in the air and Blair notes "*it really sucks in the DX signals when the band is open.*"

We also suspect it sucks in the signals *when the band is NOT open!*



ERNEST V. BLAIR and his 30 foot long-john yagi, 100 feet in the air. Ernest is the small dot on top of the antenna. Parachute anyone?

Blair's *other antennas* include stacked homebrew channel 5 yagis for CKSO-TV Sudbury, 145 miles distant over some exceedingly rough terrain.

All in all Blair's antennas show a great deal of original design and considerable testing. But like our friend Stan Hosken, in North Bay, Ontario, Canada, Blair has to date been reluctant to release design figures on his yagis so that other long range enthusiasts around the country might try their hand at duplication. *What say Ernest?*

RULES FOR SPORADIC E DXing

(1) Watch channels 2-6 for signs of rapidly developing co-channel interference.

(2) Be especially aware of co-channel interference developing on channels and in an-

tenna headings which do not normally show such interference.

(3) Check channels 2, 3 and 4 frequently (once every fifteen minutes if possible) for unusual activity.

(4) Jot down in your "*logbook*" the times and dates you see unusual DX, and keep a written record of everything you see.

(5) Be especially wary between the local standard time periods of 7:00-10:00 A.M., noon to 2:00 P.M., and 4:00 P.M. to 9:00 P.M.

VERIFICATIONS—WHAT TO DO?

Despite what cynical types will tell you, most TV broadcast stations do enjoy learning that their signals have "*reached out a little ways beyond the normal*" and that you have seen them. As a general rule, address your reports of DX reception to the "*Chief Engineer.*" If he wants to pass it along to the station's manager, all well and good. But start with the CE. When reporting, be sure to include the following information:

(1) Time, date and channel of the received broadcast.

(2) *List by times the programs, commercial announcements (audio and video) and station call slides or verbal identification seen or heard.*

(3) Report on the quality of reception (i.e., *Excellent* . . . "*better than my local station only 140 miles away*").

(4) *Give a run-down on your receiving equipment, and what other stations you were receiving at the same time (omit local stations).*

(5) If the DX reception overrode a semi or local station, tell the DX station about it. *They will be interested!*

(6) If you are writing to report reception in hopes of receiving a QSL card or written letter of verification, conclude with a phrase similar to this example: "*I sincerely hope my long-range reception report has been of interest to your engineering staff. I would greatly appreciate your checking this report against your station log, and if it is found to be correct, I would very much like a QSL card or letter confirming this reception.*"

(7) Above all, be *brief, concise and polite.* The station is doing you a favor by sending out a verification card. So treat them accordingly. There is no law which says they must do us this courtesy . . . it behooves the DXer to remember that one crank letter *demanding* a more positive statement of verification reflects on the entire hobby.

—R.B.C.

EITEL ELECTRONICS

PRESCOTT, ARIZONA



UHF-TR-10 20 WATT TRANSLATOR



VHF-TR-10/1 TRANSLATOR

Specializing in UHF and VHF, Manufacturing Translators and All Associated Equipment, Antennas, Preamplifiers, Converters—UHF and VHF

EITEL UHF-TR-10 TRANSLATOR	\$2,500
EITEL UHF-TR-100 TRANSLATOR	\$5,500
EITEL UHF-PA-100 FINAL AMPLIFIER	\$3,800
UHF-CL-4A UNIVERSAL ANTENNA—Each	\$ 200

The smallest and most efficient—complete VHF Translator!
EITEL VHF-TR-10/1, w/APC \$1,000

EITEL ELECTRONICS

PRESCOTT, ARIZONA

P. O. BOX 830 PHONE HI 5-0691

three families will continue watching TV because of this installation.

In the translator department a 100 watt Adler UHF unit is planned for the Lemon Cove-Woodlake region, with a VHF translator feeding off of this UHF unit to cover Three Rivers, a small mountain community east of Woodlake (see map). Each of these units will be installed and maintained by KFRE.

Two and possibly three more translators are under consideration.

VALLEY COVERAGE

As pointed out previously, the KFRE "market area" consists of more than 95,000 receivers located in the Fresno area and an additional 201,000 in the surrounding valley.

In the total count of nearly 300,000 receivers, the fractional appearance of the estimated 5,000 mountain region receivers is of minute importance. A broadcaster might, in fact, even go as far as "forgetting they exist," concentrating his efforts in his major market region. Nonetheless KFRE has expressed a concern for the 5,000 plus receivers which it says were purchased to receive its signal on channel 12. Now with 12 gone, the station feels morally obligated to help these people find another source of signal.

But within the San Joaquin Valley itself the coverage is something else again. The channel 30 coverage is of equal or greater "antenna terminal strength" at every point of a Horizons Publications plot. This is no mean trick! Or at least VHF engineers would like you to believe this is so.

SUMMARY

In our estimation the switch to channel 30 has been a success. The obvious loss of signal in the mountainous areas will feed the "I told you so" boys, but any good engineer and most good technicians could have predicted this (and most did).
—R.B.C.

UHF HORIZONS

(Continued from page 32)

TRANSLATOR TAX DISTRICTS

Nearly every state in the west had a Television Maintenance Bill pending before its legislature this year. Oregon's House Bill No. 1564, which was copied almost word for word from the successful Montana bill (see *DXing Horizons*, Translator Topics for April), was tabled in committee.

The bill was pushed hard by the actual translator operators but was finally defeated by opposition from the translator viewers!

KFRE-TV VOLUNTARY MOVE

(Continued from page 9)

Faced with a decision, KFRE decided to shoot for the southern San Joaquin with a favorable signal level since they consider this their prime market area.

The tilt was corrected. But the signal levels in the Sierra foothill towns remained unchanged.

It was time for KFRE to establish a rule of thumb for translators . . . and they did. "If a town or region to be covered by a proposed translator has 2500 or more people, KFRE would install the Translator." And, "if smaller towns want assistance with translator installations, KFRE will give legal and engineering aid." For the very smallest towns, KFRE would cooperate with further engineering and legal aid to help install cable systems.

The station would not participate in ownership or operation of the cable system.

To date this plan has met with favorable reception. The Edison Power Company is installing a cable system in Big Creek. Forty-



THERMATIC GAIN AND SLOPE CONTROLS FOR CATV SYSTEMS

**A Revolutionary New Concept
In Automatic Maintenance**

**of Channel Levels
Under Varying
Temperature Conditions!**

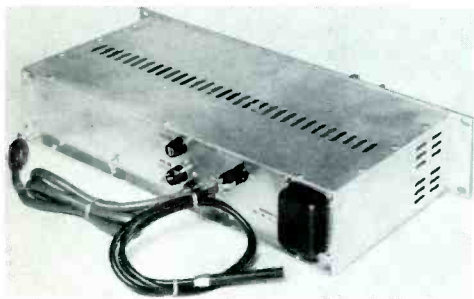

**Model 832A Thermatic Gain Control
(With Model 211C Amplifier)**

Designed for use with SKL's Models 211C and 222 Low Band and Wide Band Distributed Amplifiers, the Thermatic Gain Control compensates for variations in cable loss due to changes in ambient temperatures, by increasing or decreasing amplifier gain *as these changes occur*. The unit is inexpensive to install and saves system operators many costly hours of continuing manual amplifier adjustments.



Model 479 Thermatic Equalizer

SKL Thermatic Equalizers may be used in *any* CATV system. They *automatically* compensate for variations in the slope of cable attenuation due to temperature swings. Every day, through every season, the Thermatic Equalizers pay their way by knocking out maintenance costs for line re-equalization.

Write for further information to:



SPENCER · KENNEDY LABORATORIES, INC.
1320 SOLDIERS FIELD ROAD, BOSTON 35, MASS.

The EMCEE VHF TRANSLATOR



DESK CABINET



TECHNICAL DATA (MODEL HRV)

Input: Down to 50 Microvolts on 75 ohm line. A.G.C.: 30 db input variation produces less than 1 db output variation for signals from 50 microvolts to 50,000 microvolts.

Output: 1 watt with no measurable sync compression; 50 to 75 ohms. Mountings available: 8 1/2 rack or cabinet; self-contained outdoor housing available.

- **MODEL HRV** Complete FCC-Type Accepted VHF Translator. • **MODEL UHRV** Same as Model HRV with UHF Input Included.
- **LEGALIZER** For existing installations... provides 1 watt output... automatic on-off and identification... supplementary AGC makes compliance with FCC rules easy. Factory measured electrical characteristics minimize field measurements.

EMCEE suggests you compare...

- LOOK AT THE **SPECIFICATIONS!**
- LOOK AT THE **PERFORMANCE!**
- LOOK AT THE **CONSTRUCTION!**
- LOOK AT THE **PICTURE!**

over 100 field representatives are ready to show you the difference:



- **LOW FIRST COST** results from an efficient design and high volume production
- **INEXPENSIVE TUBE COMPLEMENT** saves you money.
- **UNIQUE BUILT-IN FEATURES** simplify installation — preventative maintenance — make it easy to have peak performance year around.

◆◆◆◆◆ Expecting higher power authorization from the FCC? Here's a guarantee of equipment availability — from the team that engineered the highest power VHF translator (150 watts for export) the model TOA-10 amplifier for a full 10 watts... only \$275.00 ◆◆◆◆◆

Warranty service stations in all principal areas. There's always someone nearby to back-up the best factory warranty, and to supply factory supervised service under contract or on an "as needed" basis.

ELECTRONICS, MISSILES AND COMMUNICATIONS, INC. 5
262 East Third Street • Mount Vernon, New York
Gentlemen:

- My community needs better television. Please rush free planning package including data sheet, complete installation check list, coverage calculation form.
- UHF input
- **LEGALIZER** for existing installations
- Please send free reprint of FCC rules covering translators.

NAME _____

ADDRESS _____

CITY _____ STATE _____

ELECTRONICS, **M**ISSILES AND **C**OMMUNICATIONS, INC.
262 EAST THIRD STREET • MOUNT VERNON • NEW YORK