



# D-i-Y

## R A D I O

AN INTRODUCTION TO AMATEUR RADIO - FOR BEGINNERS OF ALL AGES

March-April 1994

Volume Four: No 2

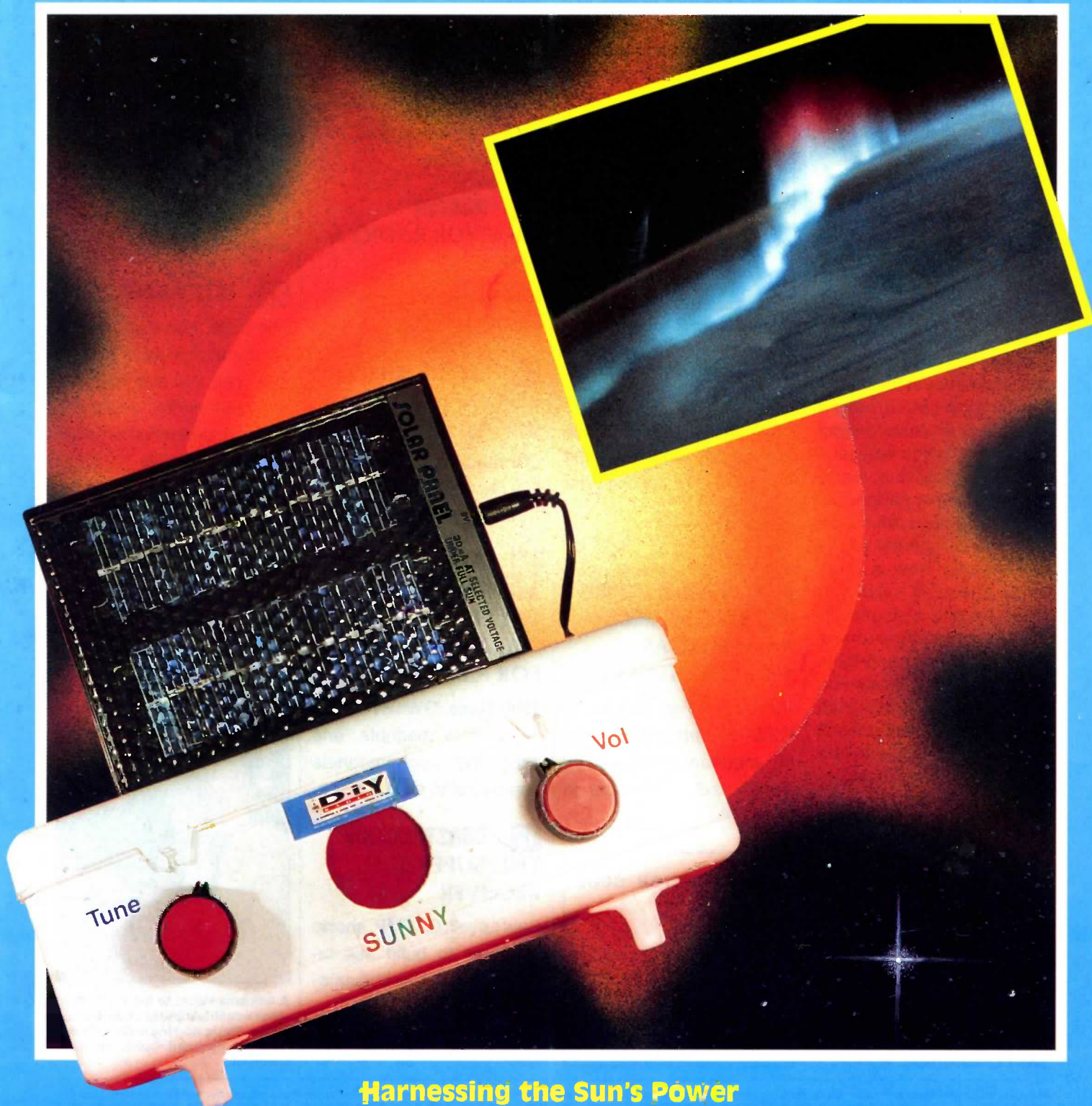

### Harnessing the Sun's Power

Available only by subscription from RSGB, Lambda House,  
Cranborne Road, Potters Bar, Herts. EN6 3JE

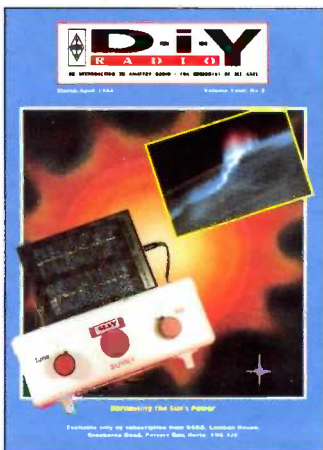

## COVER PICTURE:

Two ways to use the Sun's radiation: The *D-i-Y Radio Sunny* runs off solar power, and VHF radio signals can be reflected from The Auroral curtain (pictured here as a spectacular light display seen from space).

## comment

We at *D-i-Y Radio* do our best to ensure that your days are brightened up, and this issue certainly brings the sun out!

We have some really great projects for you to build and, if you have never tried making anything before, have a go at the Quiz Master project on page 5. When you get it working, suggest a family quiz night - this gadget will act as the perfect referee for you, and will impress all the contestants. Now a challenge to you all - can you come up with a simple circuit design that allows more than two switches and lights to be used. It would also be good if the circuit would latch in so that the button doesn't have to be held in until the quiz question has been answered. You can use transistors, ICs or relays - the most important point is that it should be simple.

If you can get to the RSGB London Amateur Radio and Computer Show at Picketts Lock on the 12 or 13 March, we can promise you a great day out. See page 14 for more information.

**Marcia Brimson, Editor.**

## 3 NEWS

A FEAST of an Idea. STARS over Africa. News in Brief.

## 5 CONSTRUCTION THE QUIZ MASTER

Steve Ortmayer, G4RAW, shows you how to build this super little gadget which can act as an electronic referee.



The Quiz Master in action.

## 6 CONSTRUCTION D-I-Y RADIO SUNNY

Paul Lovell, G3YMP, has designed this solar-powered medium-wave receiver for you to build.

## 8 RADIO: A UNIQUE AND EXCITING HOBBY AMATEURS AS SECRET LISTENERS

Part 4 of Pat Hawker's, G3VA, look at the little known but important part played by British radio amateurs in World War II.

## CONSTRUCTION CODE

FOR THE COMPLETE BEGINNER . . . . .

REQUIRES A LITTLE EXPERIENCE . . . . .

FOR THE MORE EXPERIENCED . . . . .

## 10 HAM FACTS PUTTING THE SUNSHINE TO WORK

How to harness the power of the sun by using solar cells. Save money on batteries.

## 11 REVIEW

The *D-i-Y Radio* team review four new video cassettes aimed at beginners into amateur radio.

## 12 POSTER AMATEUR RADIO & THE SUN

How the Sun affects radio signals.

## 14 ON THE AIR 2'S COMPANY/LOG BOOK/PREFIXES

Our regular columns for the listener and Novice. Plus Oceania callsign prefixes.

## 16 THE WHATS, WHYS AND WHEREFORES WHAT CAN MAGNETISM DO FOR ME?

John Case, GW4HWR, explains how magnets, and especially electromagnets can be put to practical use.

## 17 CONSTRUCTION THE 'SUPER 7' RECEIVER

Paul Lovell, G3YMP, shows you how to build this receiver for the 40 metre amateur band.



The 40m amateur band is full of signals 24-hours a day. Take a listen to it on the *D-i-Y Radio Super 7* receiver.

## 20 TECHNICAL FEATURE

## SUNSPOTS AND THE RADIO AMATEUR

Kurt Feldmesser explains what sunspots are and how they can help and hinder amateur radio propagation.

## 22 LETTERS AND DIARY

The page where you tell us what you think of *D-i-Y Radio* and how you are enjoying amateur radio. Also our regular calendar of contests, rallies and events.

## 23 PUZZLE PAGE WIN A 'GETTING STARTED' VIDEO

Win one of the super videos (reviewed on page 11) in our 'Jumblies' competition.



A welcome visitor to the *D-i-Y Radio* office was Mrs Arakawa, JG3FAR from Japan. She is working in North Wales with her husband Taizo, JA3AER/GWORTA.

● Cosmonaut Alexander Serebov uses the amateur radio callsign R0MIR from the Mir Space Station as it orbits the earth. When he is over Israel, he is frequently heard chatting to Mark, 4Z4KX, who speaks Russian. Alexander is a fan of Israeli pop singer Ofra Haza, and he asked Mark to pass on his greetings to her. This was surprisingly easy as Ofra's brother is a licenced amateur, 4Z4XC.

● The German town Bad Bentheim presents the Golden Antenna Trophy each year for an exceptional humanitarian deed in amateur radio. In 1993 the award went to the National Institute of Amateur Radio in Hyderabad, India. NIAR volunteers have helped to relieve suffering during severe floods, earthquakes and other catastrophes over the last ten years. The NIAR subscribes to *D-i-Y Radio*, so special congratulations to all of their members.

● A sad loss to the amateur radio community is Jack Toothill, G4IFF of Ipswich, who died on 14 January 1994. Jack was an enthusiastic supporter of *D-i-Y Radio* and the Novice Licence.

● Laurence Howell, GM4DMA, who has written for *D-i-Y Radio* in the past, is providing the radio communications for a three-man unsupported polar expedition which hopes to raise a million pounds for the Save the Children Fund. If your school, or your children's school, is following this expedition, we'd like to hear from you so please get in touch as soon as possible.

● International Marconi Day is held on 23 April, organised by the Cornish Radio Amateur Club. A number of special event stations from all over the world will be

# Norwich Workshop It's a FEAST!



**BETWEEN 18 AND 26 March** the Norwich Festival of Art, Science and Technology (FEAST) takes place, and members of the public can see various aspects of science demonstrated.

The Norfolk Amateur Radio Club is organizing a workshop on building a receiver, helping newcomers to find out all about amateur radio, and will run special event station, GB2NCM (Norwich Castle Museum), during this period. As the Castle Museum celebrates its cente-

operating as part of the celebration of the life of this radio pioneer. The Wireless Museum in Puckpool Park, on the Isle of Wight will be running a special Marconi exhibition, so if you are in the area call in and have a look round. Further details from G3KPO, tel: 0983 567655.

nary this year, it's an ideal location. If you're in the area during that week, go along and join in. There's free ad-

mission to the museum for one child and one adult on presentation of the special GB2NCM QSL card.

## STARS OVER AFRICA

AN INTERNATIONAL working group STARS (Support for the Amateur Radio Service) runs a network of amateur radio stations called YARIA (Youth for Amateur Radio in Africa) which meets on the air quarterly.

YARIA's objective is to put amateur radio stations in schools, colleges, universities and youth clubs, so that youngsters, supervised by licenced amateurs, can talk to other young Africans.

During February, May, August and November, nets (where more than two peo-

ple chat to each other on a given frequency) will be operating on the 40, 20 and 15 metre bands, with a special 'listening only' station transmitting on 10.125MHz CAM (an AM or SSB receiver will work). The net controller is ZS6SRL.

STARS is a project of Region 1 of the International Amateur Radio Union (IARU) which coordinates national amateur radio societies in Europe, the former USSR and Africa. The RSGB is a founder member of the IARU.

PHOTOGRAPH: BRIGHOUSE ECHO



Peter Buck, G8AUL, recently retired after a life-time's service in local government so now has plenty of time to spend on his amateur radio. He combines this with his involvement with the Brighouse and District Scouts, by training youngsters for their Communication Badge, and often runs the GB3RSS station for Jamboree on the Air (JOTA). Peter (left) is pictured operating the station with Norman, G3WAH.

PHOTOGRAPH: JOHN ALLEN, G3DOT



The Chairman of the Grimsby Amateur Radio Society, Adrian Patton, G1BRB, presents the Harold Watson Morse Key Trophy to Henry Hunter, G8FN, for his services to amateur radio. In particular this was for his work with the Novice Licence scheme in teaching Morse and 'on the air' procedure to Novices. Henry's 'young' brother is 2E0AEJ who can be found on 80m most afternoons. G8FN has been licenced and active on all bands since 1935.

NARS A

NARS A

Don't miss the **LARGEST** single day show in the U.K.

# NORBRECK

## Radio, Electronics and Computing Exhibition

by the Northern Amateur Radio Societies Association at the

**NORBRECK CASTLE HOTEL EXHIBITION CENTRE  
QUEENS PROMENADE, NORTH SHORE, BLACKPOOL**

**on Sunday, March 20th, 1994**

**Doors open at 11 a.m.**

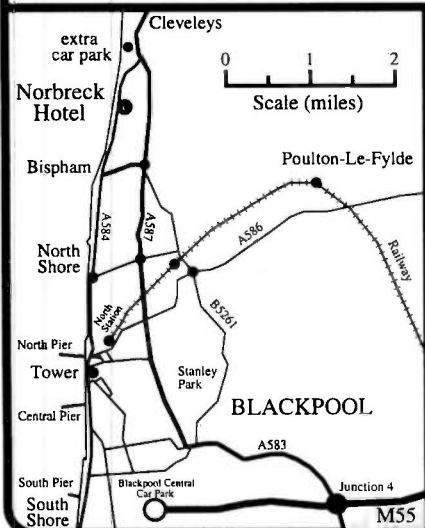

- \* Over 100 trade stands
- \* Bring & Buy stand
- \* RSGB stand and book stall
- \* Organised by over 50 clubs
- \* Free car parking (plus free bus service from extra car park)
- \* Overnight accommodation at reduced rates (contact hotel directly)
- \* Club stands
- \* Amateur Computer stands
- \* Construction competition
- \* Facilities for the disabled

## RADIO TALK-IN ON S22

Admission £1.50 (OAP's £1, under 14's free) by exhibition plan

Exhibition Manager : Peter Denton, G6CGF, 051-630-5790

BRITAIN'S BEST SELLING AMATEUR RADIO MAGAZINE

practical  
**Wireless**



Regular features include:

- Novice Natter
- Reviews of the latest equipment
- Transceiver and test equipment construction
- Bits and Bytes – The Computer In Your Shack
- Valve and Vintage
- Antenna Workshop
- Radio diary, competitions and much more

  
pw publishing ltd.

**Arrowsmith Court, Station Approach,  
Broadstone, Dorset BH18 8PW  
Tel: 0202 659910 • Fax: 0202 659950**

## THE KITS WITH ALL THE BITS!

Guaranteed complete to the last nut!

**COMPACT 80m CW QRP Tx/Rx**

DTR3 Kit — £87.50 Ready Built — £140.00

★ Stable VFO ★ Sidetone ★ Audio Filter  
★ Requires 12/14 VDC ★ Very detailed  
Instructions ★ Black steel case ★ Printed panel  
Please add £4 p&p to all prices

**COMPANION ANTENNA  
TUNING UNITS**

TU1 Kit — £41.25 Ready Built — £57.50

TU2 Kit — £51.00 Ready Built — £72.00

Please add £4 p&p to all prices

★ Large dia. coil ★ High grade capacitor ★ Built in balun ★ Circuits to match your  
antenna ★ Up to 30 Watts of CW ★ TU2 has sensitive QRP/SWR meter.

Send SAE for brochure or call Alan G4DVW on 0602 382509

**LAKE ELECTRONICS**

7 Middleton Close, Nuthall, Nottingham NG16 1BX

(callers by appointment only)



**Visit the RSGB London Amateur Radio**

on 12/13  
**MARCH**

**and Computer  
Show**

See page  
**fourteen**

## KANGA's QRP KITS

Kits from the pages of SPRAT the QRP club magazine. Various ideas from all over the world, including transmitters such as the ONER, the SUDDEN receiver and much, much more. Many for the beginner too!

Send an A5 SAE for our FREE catalogue

Seaview House, Crete Road East  
Folkestone CT18 7EG

Tel/Fax 0303 891106 0900-1900

Closed Mondays. Rallies on Sundays!



# The Quiz Master

By Steve Ortmayer, G4RAW



**NORMAN AND NANCY** Novice had been running a quiz at their radio club. It was difficult to know who answered the questions first as the ones who shouted the loudest seemed to be getting the points.

What was really needed was an electronic device like that used on television quizzes. Each of the contestants has a button which they press when they think they know the answer. The one to press first causes

their light to come on; at the same time the circuit prevents the light of the other contestants from operating. The quiz-master then knows which contestant answered first.

This project will be useful if you run a quiz at your local radio club. These are a fun way of learning about radio and electronics and they can help new members with their training for the RAE or NRAE. You may find that your school or pub quiz could be helped by your electronic wizardry.

## ONE HAND MAKES LIGHT WORK

THE CIRCUIT (Fig 1) will operate with two contestants or teams. Two transistors are used as switches. If the first contestant presses push-button PB1 a positive voltage is connected from the battery to the base of transistor TR1,

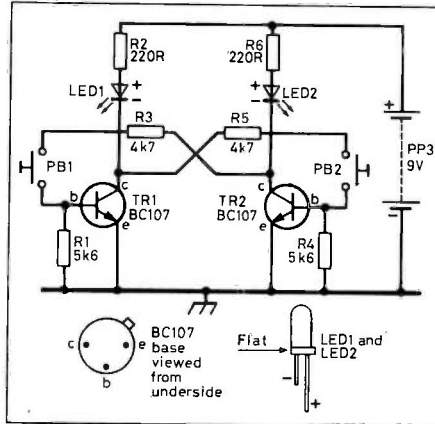

Fig 1: The circuit of the quiz-master.

via resistor R3, LED2 and R6. This positive voltage on the base of TR1 causes a fairly large current to flow through the collector/emitter junction of TR1 and LED1 lights up. LED2 does not light up because the current flow required to switch on TR1 is very low. The large current flowing through TR1 causes most of the battery voltage to be dropped across R2 and LED1. If the second contestant presses PB2, LED2 will not light up because the positive voltage at the collector of TR1 is not

high enough to switch on TR2. If PB2 were pressed first then TR2 would switch on, causing LED2 to light up. This would in turn lock out circuit PB1, TR1 and LED1.

## CONSTRUCTION

I MADE THE PROJECT on plain perforated board with wires joining up the components under the board (Fig 2). The two LEDs were left with long leads so that they could stick out through the front of the box. The two push buttons could be placed in separate boxes with twin wire leads if required.

When construction is complete check that all the wiring is correct then connect a PP3 battery. Test by pressing and holding one button and checking to see if its LED lights up. If the circuit is working correctly the other LED will not light whilst the other button is pressed.

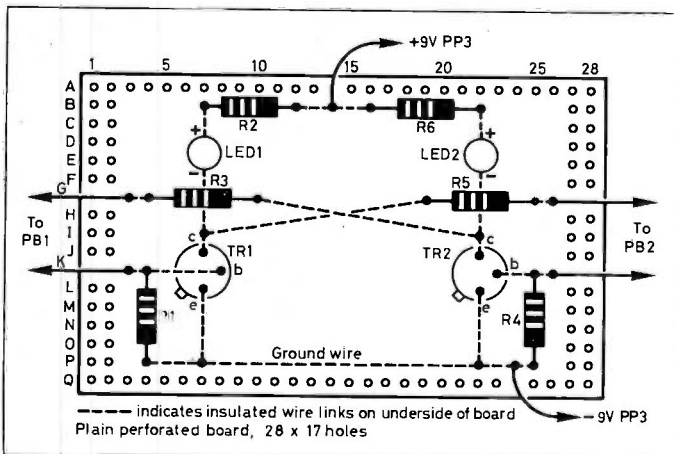

Fig 2: Component layout shown on plain perforated (matrix) board.

## COMPONENTS

### Resistors - 1/4 Watt carbon film

R1, R4 5k6; R2, R6 220R; R3, R5 4k7

### Semiconductors

TR1, TR2 BC107

Two LEDs

### Other parts

Two push buttons

Perforated board 28 x 17 holes

Plastic box 12 x 10 x 4cm (could be smaller)

PP3 Battery & snap connectors

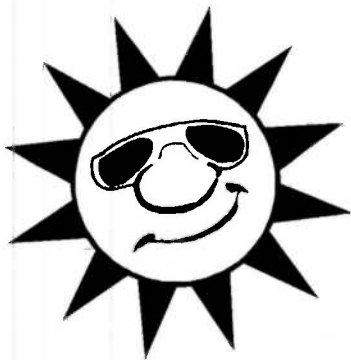

# D-i-Y Radio Sunny

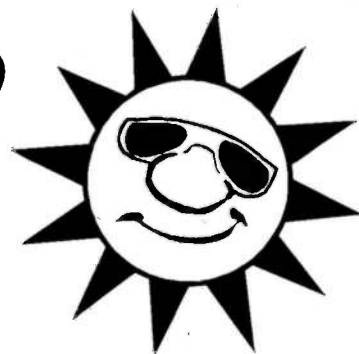

By Paul Lovell, G3YMP



SOLAR CELLS can easily provide enough power to operate a small radio receiver, and the *D-i-Y Radio Sunny* is an ideal set to take away on holiday. It covers the medium (AM) waveband, so why not laze on the beach this summer, and listen to your favourite station. But first, let's get busy with a little home construction. If you've already built some of the other circuits in our magazine then this one should be easy.

## HERE COMES THE SUN

WHAT WE ARE using for this project is not just one solar cell, but a number connected to form a solar panel. On a very sunny day, it will give eight or nine volts at a current of over thirty milliamps (mA), but when the weather is not quite so bright the circuit will still work with less than two volts. The Sunny will happily work with any voltage in between,

although the volume will be less when the solar cell is giving a lower voltage.

The radio uses a type of circuit known as a **Tuned Radio Frequency** or **TRF**. If you look at the circuit diagram (Fig 1) you will see that it has a tuned circuit consisting of variable tuning capacitor VC1 and coil L1. You can make this coil yourself by winding about 35 turns of insulated wire onto a ferrite rod. The ferrite rod should be about 10cm long and 10mm or so in diameter.

Signals picked up by the tuned circuit are passed to IC1, which amplifies them (makes the signals louder). This little circuit is actually rather clever, because it will amplify a small signal more than a large one. This helps to make the volume more constant for stations of different strength - a feature known as **automatic gain control (AGC)**. The chip also functions as a detector, converting the signal from radio to audio frequency.

Signals from IC1 are still not loud enough to drive a loudspeaker so we

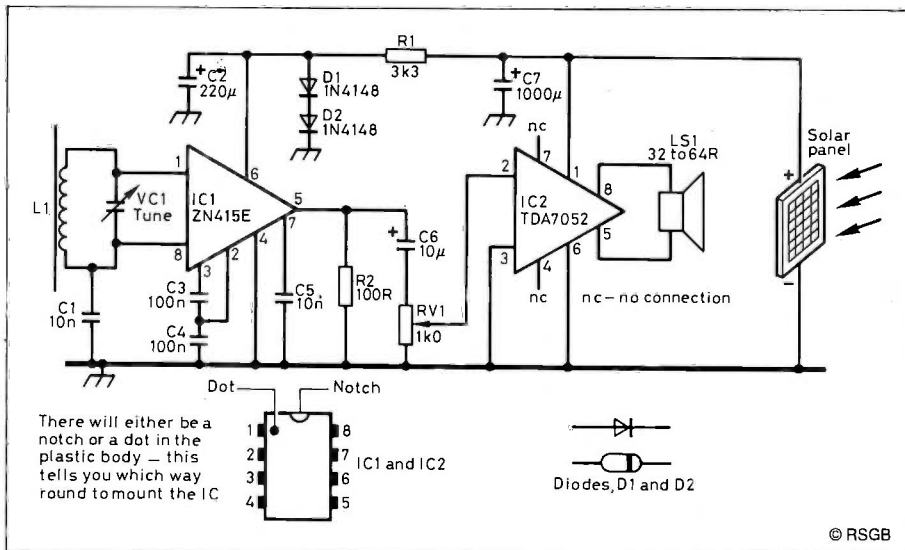

Fig 1: The Sunny uses just two integrated circuits (chips) and operates at any voltage from 2 to 9V.

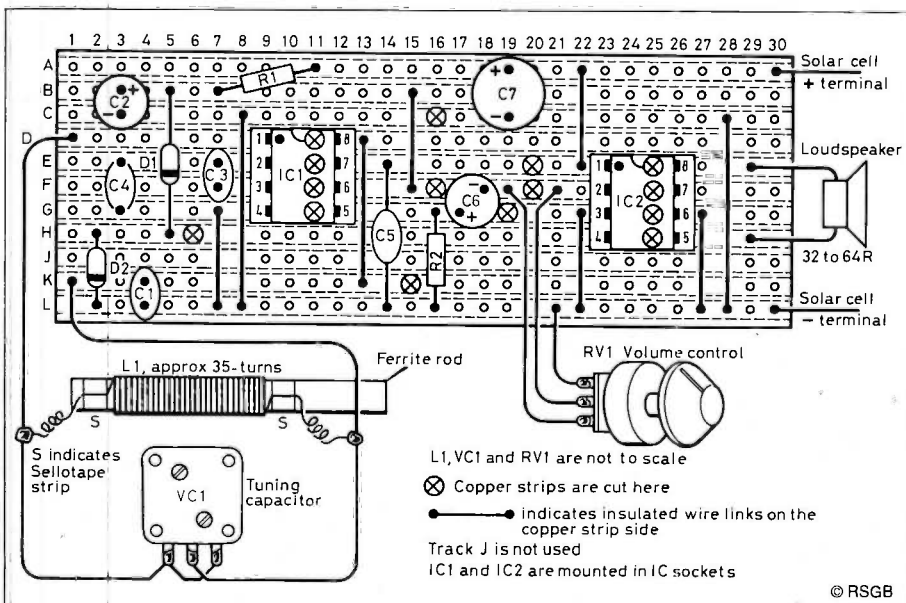

Fig 2: Follow the layout carefully, making sure that all connections are neatly soldered.

now have another circuit (IC2) known as an audio amplifier. This increases the sound signal voltage by up to 100 times, making it sufficient to drive the speaker LS1.

Now here is some good news! *D-i-Y Radio* has obtained special supplies of the ZN415E integrated circuit, which we are giving away *free* to subscribers (see page 22).

## SIMPLE TO BUILD

PROTOTYPE BOARD, also known as stripboard or Veroboard is used in the construction of the Sunny. Look carefully at the layout shown in Fig 2, and note that there are 11 strips of copper running from left to right. Break the strips with a cutting tool (eg a drill bit) where you see the crosses on the diagram. Both of the

ICs have 8-pin sockets which are soldered in first. Next fit the capacitors, making sure that you check the polarity ('+' and '-' connections) of the electrolytic types such as C5.

Resistors and diodes can now be soldered onto the board. Make sure that the resistors are the right value - the colour code chart on the poster in *D-i-Y Radio* Vol 3 No 5 may help. Solid lines running from top to bottom on the board are wire links and, as you can see, the speaker and tuned circuit connections are at either end. The volume control has three connections, and here it's handy to use different coloured wires so that you don't them mixed up.

A two-section tuning capacitor is used, with both sections wired in parallel as shown in Fig 2. The Sunny is a very unusual radio because it doesn't have an On/Off switch - when you've finished listening just turn the volume down to zero. After all, there's no need to worry about the battery running down!

## READY TO GO

THE SOLAR PANEL can be mounted on a bracket to catch the sun's rays, or it can be glued to the top of the case. On a sunny day, the radio will work indoors next to a window. Alternatively it would be possible to use a battery instead of the solar cell for indoor use. Choose one with a voltage between 6 and 9 volts.

You may need to adjust the number of turns on the coil for best results, but under most conditions it should be possible to receive at least five stations at good volume. And don't forget to watch the weather forecast.



## COMPONENTS

### Resistors - 0.25W or 0.6W 5% tolerance

R1	3k3	M3K3
R2	100R	M100R
RV1	1k0 or 4k7 variable resistor (log)	FW21X

### Capacitors

C1, C5	10n ceramic	BX00A
C2	220µF electrolytic	FB60Q
C3, C4	100n ceramic	YR75S
C6	10µF electrolytic (10 or 25V)	FB22Y
C7	1000µF electrolytic (10V)	FB81C
VC1	Tuning Capacitor 140 to 300pF	FT78K

### Semiconductors

IC1	(Free to subscribers with this issue of <i>D-i-Y Radio</i> - see page 22).	ZN415E
IC2	Philips TDA7052 audio power amplifier	UK79L
D1, D2	1N4148 diodes	QL80B
Solar panel	9V at 50mA max. output	RK23A

### Other parts

LS1	Miniature 32 to 64ohm loud speaker	YT28F
Ferrite rod	Length 100mm approx.	YG20W
Copper wire	24SWG (0.56mm) enamelled	BL28F
Plastic box	Approx. 220 x 140 x 70mm	YN39N
Strip board	2.54mm matrix board should be cut to size (11 strips wide)	JP47B
	8-pin DIL IC sockets (2 required)	BL17T
	Tuning and volume knobs (2 required)	FD67X
	Material (eg cloth) for speaker grill	
	Connecting wire	

Maplin order codes are given for most parts, but you can also obtain them from other suppliers, or salvage some of them from old equipment.

Maplin are at PO Box 3, Rayleigh, Essex SS6 8LR. Telephone: 0702 554161.

# Amateurs as Secret Listeners

Part 4 of the history of amateur radio by Pat Hawker, G3VA



WHILE A CONSIDERABLE number of amateurs were soon in uniform, either as reservists, territorials or called up under the National Service regulations which had been introduced in April 1939, there remained a large number of RSGB members and other enthusiasts who were above or below 'call up' age, or in reserved occupations or medically unfit for the Services. Soon many of these were being approached by Lord Sandhurst of the Radio Security Service (the RSS was an agency of MI5) and asked if they would undertake on a voluntary basis 'work of national importance' (no indication of what this would be was given until they had signed a statement that they understood that all information would be covered by the Official Secrets Act). They were not told that even before being approached a security 'trace' would have been made in MI5 records to ensure that nothing was known against (NKA) them! By late 1940, there were over a thousand Voluntary Interceptors (VIs), most of them pre-war amateurs or listener members of the RSGB.

## SUSPICIOUS TRANSMISSIONS

THE VOLUNTARY INTERCEPTORS were told to listen at home for any HF transmissions that could not be positively identified as coming from commercial or service stations. A booklet was provided describing how Allied and Enemy service traffic could be identified. These Army, Navy and Air Force transmissions were 'not wanted' as the German services were routinely monitored by the 'Y' services for which many of the amateurs-in-uniform were already working. Initially the task of the VIs was seen as finding suspicious transmissions that might be made by German radio-spies in the UK. But soon the VIs were helping to unravel extensive networks of HF stations throughout Europe, the Middle East, North and South America carrying traffic for the German Military Intelligence (Abwehr) service, using procedures designed to make interception difficult or to appear to be Allied rather than German transmissions.

By the end of 1940, hundreds of RSS log sheets were being sent each day to 'Box 25 Barnet' where a Discrimination Section (run by Kenneth Morton-Evans, G(W)5KJ) sorted



Watson Peat, GM3AVA, operating a Special Communications Unit station at Eindhoven, Holland in late 1944.

the wheat from the chaff and, together with VI Group Leaders (almost all pre-war amateurs) and RSS Regional Officers, encouraged the Secret Listeners to spend hours searching the HF bands, despite the 'distraction' of the air raids of 1940-41. Unlike most regular Service stations which operated on net frequencies, the Abwehr stations used call-signs which changed daily as well as separate control and outstation frequencies with the intention of making them difficult to intercept.

## CODE CRACKING

WHILE THE CIPHERS used by many of the German radio-agents were comparatively simple, the traffic between the main German Intelligence centres in occupied or neutral countries were much more secure, including those on a special Abwehr version of the German Enigma cipher machine. The Abwehr hand ciphers were broken from about December 1940, but it took another year before Bletchley Park could decipher the Abwehr Enigma traffic that flowed to Berlin from, for example, the large German radio centre in Madrid which in turn was in touch with coast-



watching agents around Spain and Portugal.

Initially, the VIs had been intended to support the Post Office which had set up three special intercept stations with direction finding (DF) facilities for this purpose in Cornwall, Scotland and Northern Ireland. But by 1941, it had become clear that the VIs were proving more effective than the Post Office stations in the hunt for Abwehr networks. The RSS decided to take over the three PO intercept stations, including some of the operators, and to set up additional stations (targeted specifically at the German and Italian Intelligence services) at Hanslope Park near Bletchley, Buckinghamshire and at Forfar, Tayside. These stations would be largely manned by operators recruited from the VIs and the PO, as 'special enlistments' in the Royal Corps of Signals.

## RADIO SPIES

1941 ALSO SAW CONTROL OF RSS, now more concerned with European networks than radio-spies in the UK, pass from MI5 to MI6/SIS (Section VIII). Both MI6 and MI5 radio sections from 1941 onwards became overtly Special Communication Units under the control of 'C', the designation of the Chief of the Secret Service (Sir Stewart Menzies), and more specifically headed by Brigadier (Sir) Richard Gambier-Parry of Section VIII. In the 1920s he had held the amateur callsign 2DV, and had been recruited by SIS in 1938. Section VIII headquarters was at Whaddon Hall, near Bletchley.

The Special Communication Units, with a mixture of civilian, services and former amateur operators and engineers, were responsible for many other aspects of the secret radio war: the distribution of 'Ultra' information gained primarily from the Y-service interception of German service traffic; the RSS interception of Intelligence traffic;

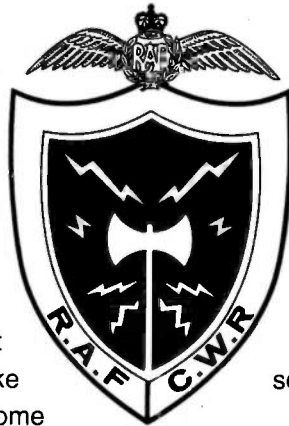

the clandestine links with the secret radios of the Intelligence and Resistance groups in Occupied countries; diplomatic and Intelligence links with British embassies in Allied and neutral countries; the provision of the 'black broadcasting' transmitters that operated independently of the BBC; and the design at Whaddon Hall of portable 'suitcase' sets for use by the radio-agents.

## THE SECRET WAR

A SEPARATE organisation - the Special Operations Executive set up in 1940 - became responsible for some of the clandestine Resistance and para-military communications. Amateurs again made up a significant part of the engineers and operators responsible for designing a range of 'suitcase' and miniature equipment, including the famous B-2 suitcase transmitter-receiver designed by the late John Brown (post-war G3EUR).

In the occupied countries, a proportion of the operators of the secret radios were pre-war amateurs with some of the transmitters put together secretly under the noses of the occupation forces. In Holland and Denmark pre-war amateurs, in the final period, set up radio links using locally made equipment of their own design. In Norway, a production line for 'Olga' transmitters was established in Oslo. The Poles based in London played a major part in the secret radio war - providing links not only with the Polish Home Army but also with Intelligence groups in France and North Africa. Their London-designed equipment was for several years recognised as the best of the clandestine radios. Senior members of the Czech Intelligence Service had escaped to England in March 1939 and established radio links with their home country etc, initially from a house in West Dulwich, London.

Pre-war amateurs and short-wave listeners came to be recognised as providing technical and operating skills in all branches of the Services for communications also for radar, with a minimum of time-consuming training. Some became instructors and the RSGB's *Amateur Radio Handbook* was adopted as a training manual by the RAF. The presence of amateurs in the Service establishments also served to interest others in the hobby. Despite the absence of amateur radio activity, the RSGB ended the war with double the number of members that it had in 1939!

(Top of page) Emblem of the Civilian Wireless Reserve set up in 1938. First announced at an RSGB Convention, its members were mostly amateurs.



Group Leaders and staff of the Radio Security Service in 1945, including many leading radio amateurs. Centre (with pipe) is Lord Sandhurst who recruited the amateurs as VIs in 1939-41.

**... to be continued**

# Putting the Sunshine to Work

How you can harness the power of the sun



**SOLAR ENERGY PROVIDES** a fascinating way of powering electronic circuits. For watches and calculators which need very little power, solar cells are ideal, even in a country like Britain. To carry out simple experiments, you will need a solar panel and these are obtainable from a number of electronics suppliers such as Maplin Components.

## SUNNY SIDE UP

FIRST, LET'S HAVE a look at how solar cells (more correctly known as **photovoltaic** devices) work. A few years ago, they were made from a chemical element called Selenium, but nowadays are made from thin slices of two types of silicon crystal. During manufacture a small amount of a chemical called Boron is added and this results in **p-type** silicon. A different process adds a small trace of Phosphorus, which results in **n-type** silicon. As you may have guessed, 'p' stands for positive and 'n' for negative.

Both these varieties of semiconductor are used in the construction of a solar cell, (**Fig 1**). Radiation, which in this case takes the form of visible light, enters the cell and creates a flow of **electrons** (negatively charged particles) which flow between one terminal of the solar cell and the other. This flow of electrons is electrical power - and has the same effect as the current from a battery.

In bright sunlight, a typical solar cell will produce about 700mV (0.7 volts) at a current of between 20 and 60 milliamps (mA). However, the cells can be connected in series or parallel for greater voltage or current. The *D-i-Y Radio* 'Sunny' receiver uses a solar panel which has 24 cells connected to give up to 9V at 50mA. Solar panels of

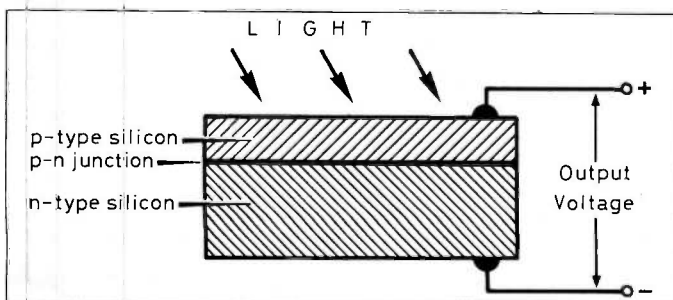

Fig 1: A solar or photovoltaic cell converts light to electrical energy.

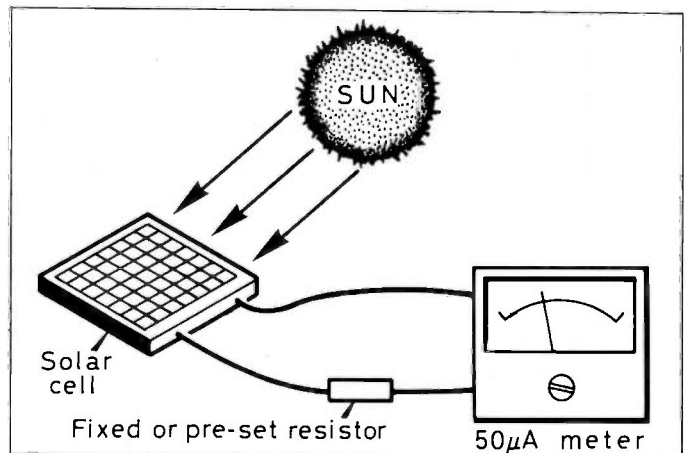

Fig 2: Simple light meter. Try different resistor values to see which of them give best results.

even higher power are available; 3ft by 1ft panels giving 14.5V at 700mA are available from Bull Electrical (telephone 0273 203500).

## EVERY DAY A 'SUN' DAY

IN MANY PARTS of the world, solar cells are an ideal source of power, particularly in tropical or desert areas, which have plenty of sunny weather but no mains electricity supplies. It's common to use solar energy in conjunction with rechargeable batteries, so that radio equipment, for example, can also be used at night or on cloudy days. Space satellites use very large solar panels, sometimes more than ten metres across.

*D-i-Y Radio* readers interested in photography might like to construct the simple light meter shown in **Fig 2**. Try experimenting with the value of resistor R1, so that the meter reads about half-scale under average lighting conditions. A value of 2k2 should be about right for a 50µA meter. Make a note of the meter reading and the settings on your camera.

Some radio amateurs have used solar powered portable transmitters to make contacts over hundreds of miles. Although large solar panels are quite expensive, they weigh much less than batteries and are often used by explorers and mountaineers, for whom radio communication is often a matter of life or death!

# 'Getting Started' Video Tapes

A review of four videos produced by CQ Communications



## GETTING STARTED IN HAM RADIO

is aimed at the beginner and is a very good introduction to ham radio. It describes what amateur radio is and how to become involved in its various aspects, such as VHF FM, Mobile, HF DXing etc.

There is a useful section on how to select and buy equipment including new and second hand equipment from radio rallies.

Setting up a radio station is described with examples of station layouts and the advantages of various antennas. We were glad to see a section on soldering but there was no mention of home-built equipment or kits.

## DXING

GETTING STARTED IN DXING is aimed at the Novice or newly licensed radio amateur who wishes to work the more elusive DX stations. Advice is given by experienced hams.

DXers thought that antennas were most important; others felt that a good receiver was best. All agreed that "if you can't hear them you can't work them". All advocated listening, patience and persistence. I was encouraged to see that many successful DXers ran fairly modest stations.

DXing is not just restricted to the HF bands. Although VHF line of sight propagation might be a limitation on earth, propagation in space can be billions of miles. While it did not suggest communication with aliens it did discuss satellite and moonbounce as a means of VHF/UHF DX communication.

## SATELLITES

GETTING STARTED IN AMATEUR SATELLITES is an introduction to space age amateur radio. Graphics are used to describe basic satellite operation, the types



The use of computers from *Getting Started in Amateur Satellites*.

of satellite in orbit and their capabilities. Terms such as Doppler shift and the different modes (which determine the uplink and downlink frequencies) are clearly described.

Advice on low cost equipment is given. At the other end of the scale, the video stresses the need for a low noise preamplifier at the receive antenna to boost the very weak signals from satellites OSCAR 10 and OSCAR 13. Veteran operators' stations are shown as examples of how the

problems of satellite tracking and low signal communications were overcome.

## PACKET RADIO

IF YOU ARE INTERESTED in computers and the digital communications side of amateur radio then *Getting Started In Packet Radio* is for you. It shows you what equipment is required, and describes definitions of common phrases such as: making packet contacts; working packet via satellite; using packet bulletin boards; and using packet networks.

## GENERAL

WE THOROUGHLY recommend these tapes, as they present the subjects in an interesting and professional manner. They really do stick to the theme of 'getting started' and should be of particular interest to clubs where the video

could be used in conjunction with a club talk to beginners. However, please note that some references to licencing and electrical safety practices may not apply to the UK.

Thanks to Nevada Communications Ltd who supplied review copies. The videos are available at £19.95 each, plus £1.25 post and packaging, from Nevada, 189 London Road, North End, Portsmouth PO2 9AE.



Soldering techniques from *Getting Started in Amateur Radio*.

# Amateur Radio & the Sun

## Propagation of HF Radio Signals

High Frequency (or short wave) radio signals can travel much further than line-of-sight by reflecting (actually refracting) from layers of gas hundreds of kilometres above the Earth's surface. The signals bounce off these

layers, or *regions*, because the gases are *ionised* by the sun's rays. Because of this their effectiveness depends on the time of day and the time of year; day-time and the summer being better for the higher frequencies (say, above 10MHz) and night-time and winter being better for the lower frequencies.

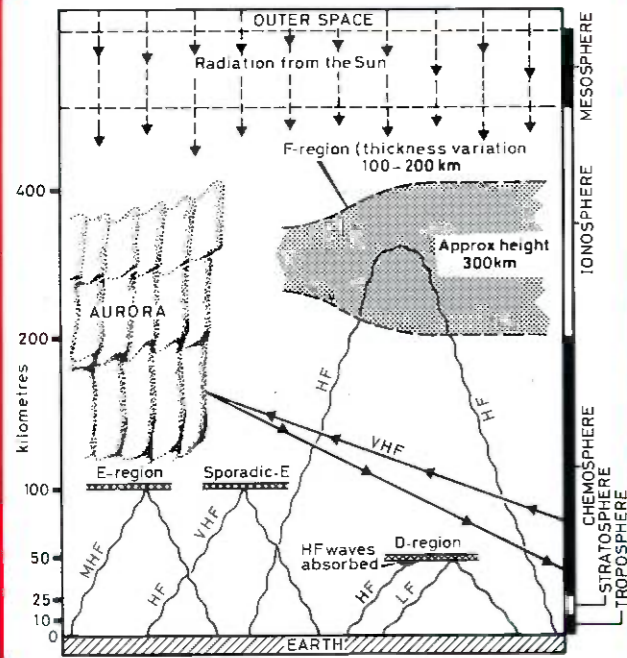

sunspot maxima. Periodically, solar flares on the sun release streams of high energy particles. These particles create auroras (curtains of ionised gas) in polar regions of the earth. An aurora can propagate VHF signals over long distances for periods of a few hours at a time.

## Propagation of VHF Radio Signals

VHF signals above (30MHz) are less affected by solar activity although at 50MHz very long distant propagation can occur at

## Sunspots

Sunspots are areas of the sun which are less hot (about 3000°C) than the rest of the sun's surface (about 6000°C) and therefore appear dark. They produce intense radiation which make the *ionosphere* reflect radio signals. The spots last from a few days to a month or two and the quantity of sunspots is directly related to the effectiveness of the ionosphere in reflecting short-wave signals as can be seen from this graph (top line - sunspot count; bottom line - effectiveness of ionosphere).

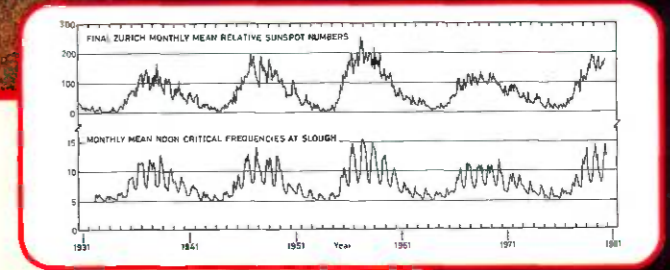

## How to view Sunspots safely



**IMPORTANT WARNING:** Never look at the sun directly through a telescope or binoculars, even with a dark filter added. This causes permanent severe damage to your eyes!

The safe way to look at the sun is by projection as in the photograph. The binoculars are mounted on a tripod and the sun's rays are directed through a hole in a piece of thick cardboard. The image is then projected onto a piece of white card. Sunspots should be clearly visible using this method.



# 2's Company

## News and Reports from Novice Licensees



FROM NOVICE INSTRUCTOR Peter Swynford, G0PUB, comes the news that the Reading and District Amateur Radio Club has an award - the A1 Award - for the youngest club members to gain a G0 and a 2E0 callsign. The 1993 winners were Malcolm Wilson, G0TFU (17), and Matthew Richie, 2E0AGM (15). They were both presented with 12 months membership of the RSGB. Matthew has more than this to be proud of, as he has already passed the 12WPM Morse test ready for when he gets through the RAE, and he won the club's 1993 construction trophy!

### LONDON SHOW

THE RSGB LONDON AMATEUR RADIO and Computer Show will be held on 12 and 13 March (10 am to 5 pm). It is a great place to learn more



David, 2E1BVW, and Mark, 2E1BUX, demonstrated 10GHz amateur television at the 1993 Caravan Club Annual National Rally with John, G3WFK.

about amateur radio and to pick up radio and computer bargains. Be careful, though, when buying something second-hand; if it is really cheap there's probably a reason, such as it doesn't work! Having said that, a big rally such as this is just the place to stock up on components and books and magazines.

Many traders will do special rates for Novices so why not explain that you're

a beginner, you may be surprised what you get.

The show is run by the RSGB, RadioSport Ltd and the Southgate Amateur Radio Club. Most of the rally officials will be Southgate club members and this includes Mary, 2E0AEF; Rod, 2E1BUC; Stuart, 2E1BUP; Tony, 2E1BRE; Malcolm, 2E1BFL; Margaret, 2E1AQS (who we've featured before in this column) and George, 2E1AQQ.

The Show is at the Lee Valley Leisure Centre, Picketts Lock Lane, Edmonton, London N9. There will be nearly 150 trade stands, featuring everything from the very latest shiny, expensive equipment to components, disks and surplus gear. There's a big RSGB stand where you can renew your *D-i-Y Radio* sub, join the RSGB, get advice, find out about local clubs and Novice courses and buy books. See you there!

### THE LOG BOOK

UHF REPEATERS can be heard between 433.000MHz and 433.375MHz and there's probably one near you. They can be very useful indicators of radio conditions because they all send a callsign in Morse every few minutes. With a little practice it is possible to identify a distant repeater.

GB3AN is a repeater on **Anglesey** and transmits on 433.200MHz. It has recently moved site and it should be possible to hear it all around North Wales and Merseyside. GB3AN has a link to the 144MHz (2m) repeater GB3AR and it's legal for Novices to use the link to talk to 2m stations. The **Swindon** UHF repeater, GB3TD, is back on

the air with a new site and a new frequency (433.075MHz).



This Award was presented for courtesy and professionalism in Morse operation to 2E0AFW and 2E0AGN/G7ASH.

This edition of *D-i-Y Radio* deals with the effect of the sun on radio signals. Although it is the sun that makes the ionosphere bounce radio signals around the curve of the earth, a solar flare can stop this reflection completely. Just as we went to press, a number of flares made the short-wave bands very quiet indeed.

However, a side-effect of a flare is that VHF signals can be reflected from the auroral curtain (see poster page) to allow contacts with stations as far away as Scandinavia or even Russia. Signals via aurora have a very rasping sound making SSB stations sound like they have a bad sore throat.

# Prefixes

## Everything You Need To Identify Amateur Callsigns: Part 5



EVERY CALLSIGN starts with a combination of letters and numbers to indicate in which country the station is located. In this issue we list the common prefixes used in **Oceania**. A complete list of prefixes can be found in the RSGB Radio Call Book and Information Directory which costs £11.50 (including postage) from: RSGB (book sales), Cranborne Road, Potters Bar, Herts EN6 3JE.

3D2	.....	Fiji
3D2	.....	Conway Reef
3D2	.....	Rotuma Island
5W	.....	Western Samoa
9M6, 8	.....	Eastern Malaysia
A3	.....	Tonga
C2	.....	Nauru
DU	.....	Phillipines
FK	.....	New Caledonia

FO	.....	French Polynesia
FW	.....	Wallis & Futuna Island
H4	.....	Solomon Islands
KC6	.....	Belau (W Caroline Islands)
KH0	.....	Mariana Island
KH1	.....	Baker, Howland Island
KH2	.....	Guam
KH3	.....	Johnson Island
KH4	.....	Midway Island
KH5	.....	Palmyra, Jarvis Island
KH5K	.....	Kingman Reef
KH6	.....	Hawaiian Islands
KH7	.....	Kure Island
KH8	.....	American Samoa
KH9	.....	Wake Island
P2	.....	Papua New Guinea
T2	.....	Tuvalu
T30	.....	W Kirbati (Gilbert Islands)
T31	.....	C Kirbati (Brit Phoenix Islands)
T32	.....	E Kirbati (Line Islands)
T33	.....	Banaba Island (Ocean Island)

V6	.....	Micronesia
V7	.....	Marshall Islands
V8	.....	Brunei
VK	.....	Australia
VK0	.....	Macquarie Island
VK9	.....	Lord Howe Island
VK9	.....	Willis Island
VK9	.....	Christmas Island
VK9	.....	Cocos-Keeling Island
VK9	.....	Mellish Reef
VR6	.....	Pitcairn Island
YB-YH	.....	Indonesia
YJ	.....	Vanuatu
ZK1	.....	South Cook Island
ZK1	.....	North Cook Island
ZK2	.....	Niue
ZK3	.....	Tokelau Island
ZL-ZM	.....	New Zealand
ZL7	.....	Chatham Island
ZL8	.....	Kermadec Island
ZL9	.....	Auckland Island & Campbell Island

### THE LOG BOOK

Aurora warnings are broadcast on the RSGB's GB2RS News Service (3.65, 7.048, 51.53 and 145.525MHz Sunday mornings).

Interesting stations on the air recently included **3Y0PI**, an expedition to the tiny uninhabited **Peter 1st Island**, off Antarctica. As is usual in Winter, the LF bands produced some exotic DX, such as **VQ9QM (Chagos Is, Indian Ocean)**, **VS6WO (Hong Kong)** on 80m; and **JA1HQT (Japan)**, **A71CW (Qatar)** and **KP2A (US Virgin Is)** on 160m.

A big HF contest coming up is the **CQ Worldwide WPX Contest** which takes place over the whole weekend of 26/27 March. Points are scored from contacts with differ-

ent callsign *prefixes* so you'll hear all sorts of unusual (and puzzling) callsigns.

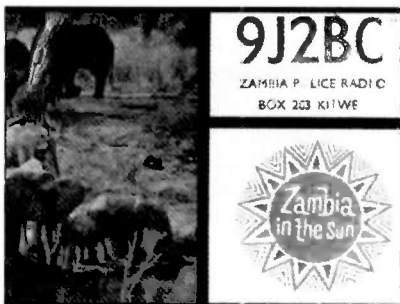

QSL cards often show something which the country or area is famous for, as this Zambian one illustrates.

Those equipped for the microwave bands will benefit from the RSGB 1.3 and 2.3GHz Fixed Station Contest on 10 April. It runs from 1700 to 2100 UTC (that's the same as GMT) and includes a Listener section, too. Contestants exchange a code known as the QTH Locator. These locators can be found on the large map which you received when you first subscribed to *D-i-Y Radio*.

We're coming up to Spring now and the HF bands will be good for contacts with Australia and New Zealand (see our list of Oceania prefixes). On VHF and above, portable stations will start to appear on the bands once again.

# What Can Magnetism Do For Me?

By John, GW4HWR, Chairman RSGB Training and Education Committee

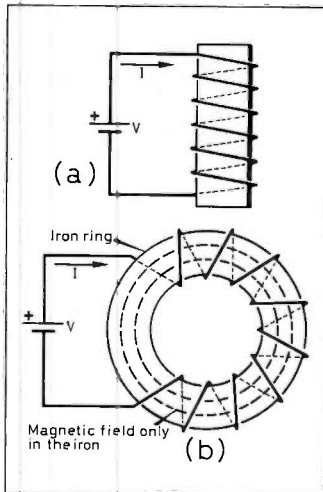

Fig 1: A coil wound on (a) an iron bar or (b) a toroid will have a much stronger magnetic field than an 'air spaced' one.

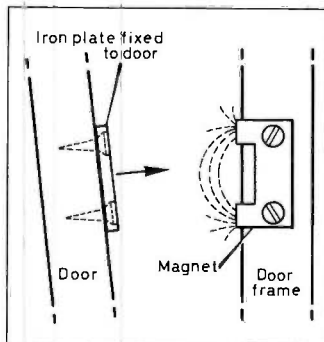

Fig 2: A magnetic door catch.

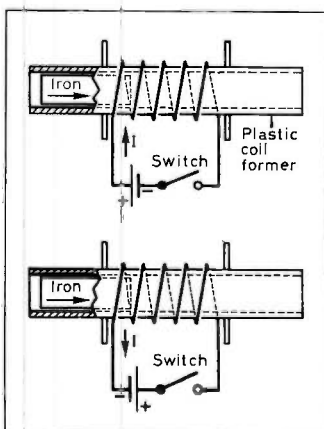

Fig 3: The direction of current flow in a solenoid is not important.



ANYTHING CAPABLE of carrying an electric current is known as a **conductor**; this is usually a wire.

A **magnetic field** is a force surrounding a current-carrying conductor, and this becomes much stronger (perhaps twenty times as much) if it can exist in iron (Fig 1).

A coil of 100 turns, carrying a current of 1A will produce a magnetising force of  $100 \times 1 = 100$  **Ampereturns** (100AT).

It is for this reason that magnets 'collect' bits and pieces of iron around the ends (**poles**). They are trying to close the gap between the North and South poles with iron. The effect is put to use in many ways. In Fig 2 the magnet has to produce a magnetic field in air while the door is open but when closed the iron armature closes the air gap and the door is held closed.

The coil shown in Fig 3 is sometimes called a **solenoid**. The diagram shows that the iron will be pulled into the coil when the switch is closed and the direction of current flow is not important.

Electric door chimes make use of this effect (Fig 4). When the bell push is pressed, the current causes the iron armature to move rapidly into the solenoid and to strike one chime. When the push is released a spring pushes the iron back and it strikes the other chime. It will work just as well with alternating current.

A **relay** (Fig 5) is just a switch which is operated when current flows through the solenoid. Relays were used in telephone exchanges, traffic lights etc, though they have been replaced by transistors nowadays. Relays are still used in many transceivers to switch the aerial from the receiver to the transmitter.

A novel use of a solenoid is shown in Fig 6. It is an unusual form of electric motor. The cam A and the contacts B are arranged so that the contacts close just as the iron **armature** C is about to enter the coil and it is pulled in. When the iron is right into the coil the cam allows the contacts to open and the 'flywheel' action maintains the motion until the contacts are closed again.

In all of the above the direction of the current doesn't matter but if the iron armature in Fig 3 is replaced by a bar magnet things change. If the fields of the magnet and the coil assist one another the magnet would be pulled into the coil but if they oppose the magnet will be pushed out.

A loudspeaker makes use of this effect, except that the magnet stays still and the coil moves (Fig 7). The cone which is attached to the coil moves in one direction when the current flows one way and in the opposite direction when the current is reversed. Try to imagine what would happen if the loudspeaker did not use a magnet.

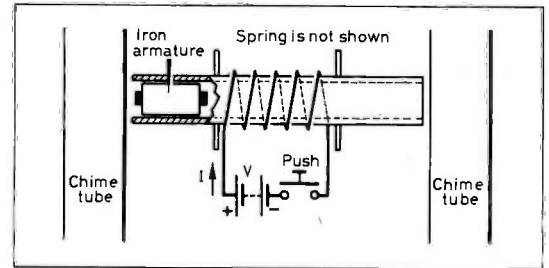

Fig 4: A spring and a solenoid make door chimes.

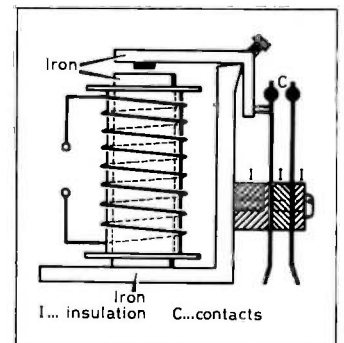

Fig 5: A relay is another practical use of a solenoid.

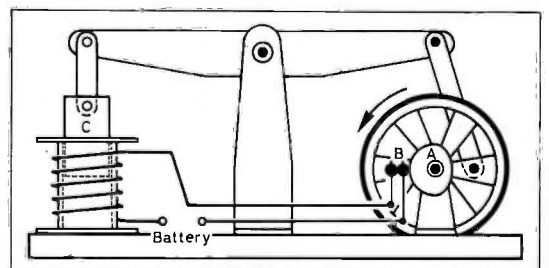

Fig 6: A magnetic beam engine.

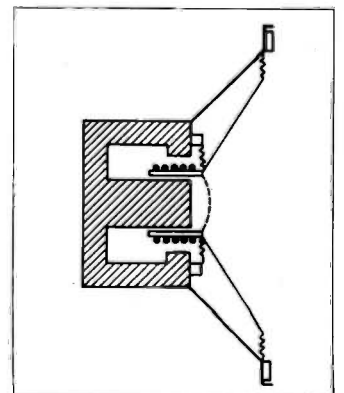

Fig 7: A moving coil loudspeaker.

# The 'Super 7' Receiver

By Paul Lovell, G3YMP



RECENTLY, THE 7MHz (40 metre) amateur band has been alive with interesting stations. It covers frequencies between 7MHz and 7.1MHz - just below the 41 metre broadcast band. One weekend, I counted 12 special event stations during the daytime and during the hours of darkness there were stations from all over Europe. Careful listening enabled stations from even greater distances to be heard on CW (Morse code)!

## GET BUILDING, START LISTENING!

SO WHY NOT share in this experience?

The Super 7 offers a fascinating insight into the world of amateur radio - if you can solder and have some experience of the simpler construction projects from *D-i-Y Radio*, this could be just the radio for you. More experienced constructors may choose to build the set on prototype



board, but there is also a kit (including a PCB) available to simplify construction (see opposite page).

Fig 1 shows the circuit diagram of the Super 7. The receiver will work with either headphones or a loudspeaker. The small speakers which can be used with Walkman

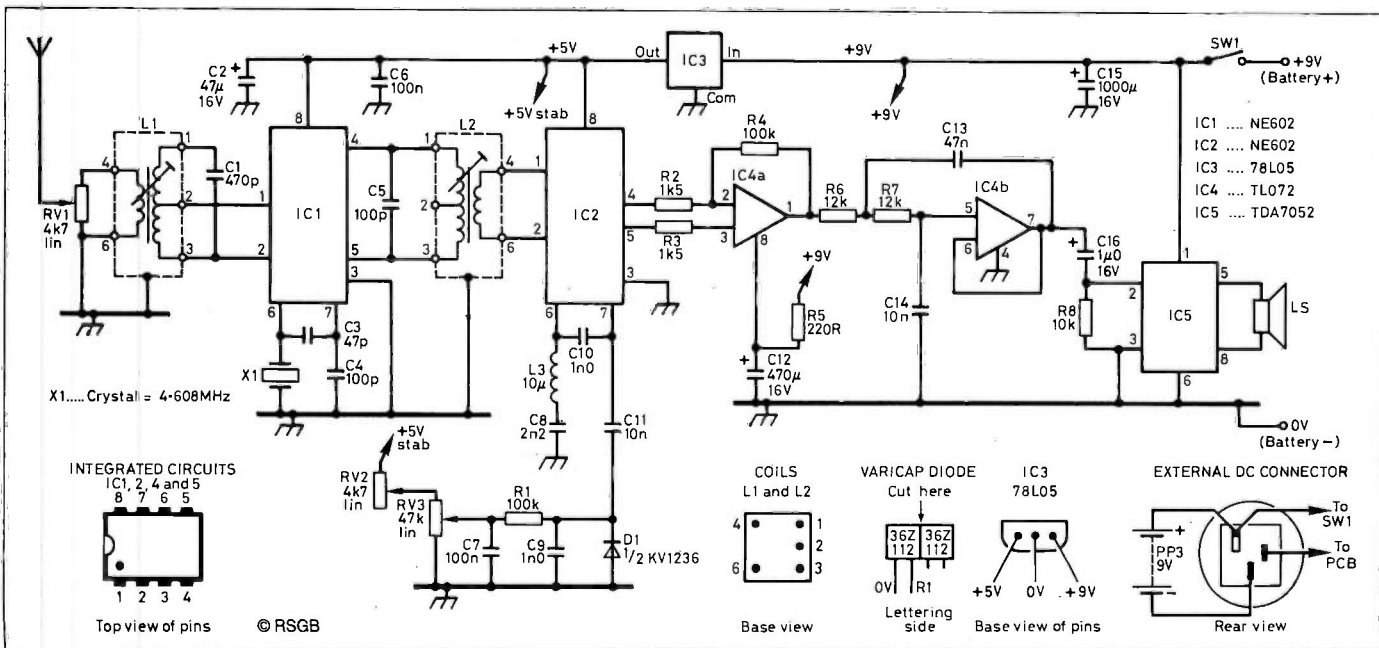

Fig 1: The Super 7 receiver gives good performance on the 7MHz amateur band as well as being simple to construct and align.



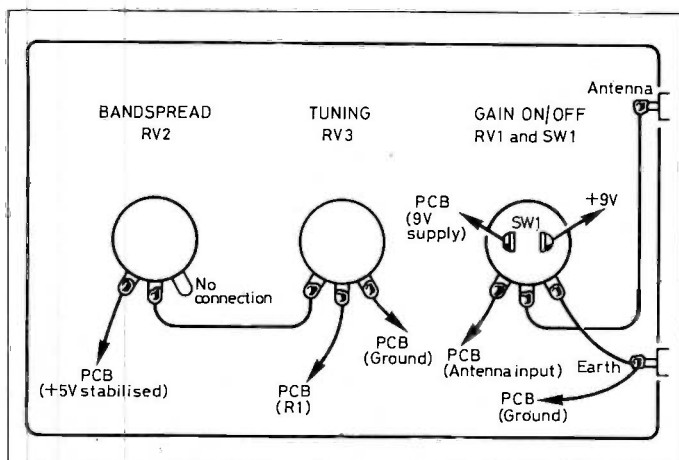

Fig 2: Rear view of the variable resistors. Check the connections carefully to make sure the wires are fitted correctly.

cassette players are ideal. If you don't want to buy the kit, all components are available from a number of suppliers - make sure you have all the necessary tools and components before starting construction.

## KEEP SOLDERING ON

SIGNALS ARRIVING at the antenna are coupled into IC1 via gain control RV1. Note that this control also has the On/Off switch to turn the radio off when turned anti-clockwise. Tuning is carried out by varying the DC voltage on varicap (variable capacitance) diode D1. This is a dual type which must be cut down the middle *carefully* with a sharp knife. With the lettering facing you, the 0V (ground) lead is on the left hand side.

The IC sockets should be soldered first, followed by the coils (inductors). Next come the varicaps, capacitors, wire links and resistors. Make sure you wire the voltage regulator (IC3) correctly, and check the polarity of the electrolytic capacitors. Crystal X1 is rather fragile, so be careful with this one. Fig 2 shows the rear view of the front panel controls - bandsread, tuning and gain-on/off - and how to wire them up.

Before you put the ICs in their sockets, check the voltages on the following pins with a 9V battery connected to the set: Pin 8 (positive) to Pin 3 of IC1 and IC2 should read about 5 volts. Pin 1 (positive) to pin 6 of IC5 should be about 9 volts. If all is well, switch off the power and fit the ICs in their sockets. Using fine stranded wire with different colour insulation will help you identify the connections.

The case can be any small plastic box, size approximately 22 x 15 x 8cm. Three 10.5mm diam. holes should be drilled in the front, with 8mm holes on the left side for antenna and earth connections. On the right hand side is a 6.3mm hole for the speaker socket and an 11mm hole for the external power (9V), which can be used instead of a battery.

## COMPONENTS

### Capacitors - All rated 16V or more

C1	470pF polystyrene 5% or better
C2	47µF electrolytic
C3	47pF polystyrene 5% or better
C4, C5	100pF polystyrene 5% or better
C6, C7	100n ceramic
C8	2n2 polystyrene 5% or better
C9, C10	1n0 polystyrene 5% or better
C11, C14	10nF ceramic
C12	470µF electrolytic
C13	47n ceramic
C15	1000µF electrolytic
C16	1µF electrolytic

### Resistors - All 0.25W 5%

R1,R4	100k
R2,R3	1k5
R5	220R
R6,R7	12k
R8	10k
RV1	4k7 linear variable with switch (SW1)
RV2	4k7 linear variable
RV3	47k linear variable

### Inductors

L1	Toko KANK3335R
L2	Toko KANK3333R
L3	10µH 5% tolerance (eg Toko 283AS-100)

### Semiconductors

IC1, IC2	Philips NE602 or NE602A
IC3 78L05	5V 100mA regulator
IC4 TL072	Dual op amp
IC5 Philips TDA7052	Audio amp.

### Additional Items

Varicap diode	Toko KV1236 (cut into two sections - one half used)
Crystal	4.608MHz (suitable type available from Cirkit)
2 silver knobs	20mm diam approx with pointer
Plastic case	approx 22x15x8cm.
Speaker	between 8 and 32ohms impedance, (or headphones)
8-pin sockets for IC1,2,4 and 5	
4mm Antenna(red) and Earth(black) sockets	
3.5mm chassis mounting speaker socket	
DC power socket for external power supply (if required)	
Tuning knob with pointer eg 37mm PK3 type	
Printed circuit board (PCB) or prototype board	

A kit of components including PCB, wire, knobs, sockets, case etc is available price £35.95 including P&P from JAB components. Please note that the colour of the case is subject to availability.

JAB Electronic Components, The Industrial Estate, 1180 Aldridge Road, Great Barr, Birmingham B44 8PE  
Tel: 021 366-6928



## CHECKING AND TUNING

AN ANTENNA for your Super 7 should be 30-70 ft of wire positioned as high as you can make it, and away from buildings if possible. Connect the battery, switch on and adjust L1 and L2 in turn for best results. Tune carefully with

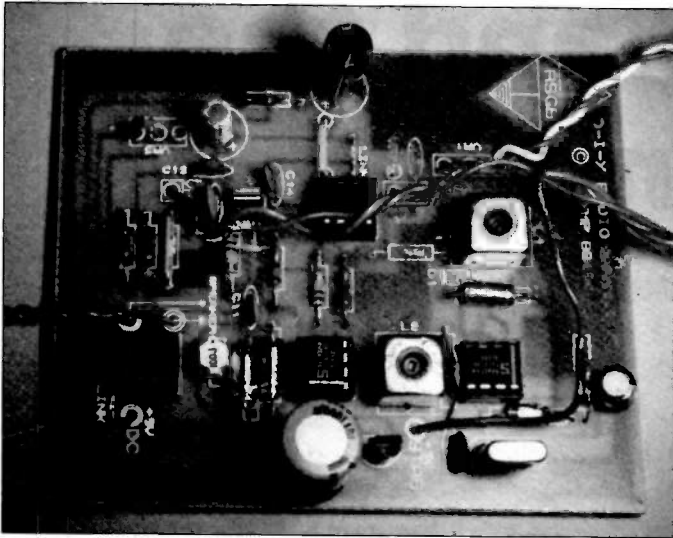

The Super 7 may be built either on a prototype board or a PCB.

the main tuning and bandspread controls until you hear amateur stations - SSB at the upper end of the band (tuning clockwise) and CW at the lower end. You will probably find the adjustments easiest to make if they are done before the controls are mounted in the case.

Next, mount the PCB on the back of the case using strong

sticky tape, and secure the battery. If you plan to do a lot of listening (and who doesn't?) then a mains adaptor is a good idea.

This should be a safety-approved stabilised 9V type. If you find that the tuning doesn't quite cover the lower end of the band, try increasing the value of C9 to 1200pF. If the top (SSB) end is just out of reach, it may help to make this component 820pF.

**SOME FINISHING TOUCHES**

MORE ARTISTIC *D-i-Y Radio* readers could no doubt design a smart front panel for the Super 7. Results can be improved by adding an antenna system tuning unit (ASTU) - a suitable one to build yourself was described in the Vol 2 No 6 issue of *D-i-Y Radio*. Results are very dependent on the antenna you use, and it's worth taking some trouble to get this aspect of your station right.

I hope that the Super 7 will bring you a great deal of listening enjoyment; it's surprising how effective such simple receivers can be. The *D-i-Y Radio* editor would be delighted to know what stations you can hear. 'Happy Listening and Good DX!'

**SUPER 7  
RECEIVER  
KIT OFFER**

The kit for the receiver featured on page 17 is available from JAB Electronics, The Industrial Estate, 1180 Aldridge Road, Great Barr, Birmingham B44 8PE, tel: 021 366 6928. The cost is **£35.95 (inc P&P)** with one of the special *D-i-Y Radio* vouchers (Page 23). Kits ordered without a voucher cost £36.45.

**OFFER CLOSES  
30 APRIL 1994**

**Become a regular D-i-Y'er**

Get the next six editions of *D-i-Y Radio* PLUS a bag of goodies for the special price of **£9** (overseas prices on application). Send cheque or postal order to: RSGB, Lambda House, Cranborne Road, Potters Bar, Herts EN6 3JE.

**GUARANTEED!**

.....

**£1.70**  
per issue

Every issue of *Ham Radio Today* for a whole year with our **Direct Delivery Service**.

*HRT* is always up to date with your needs and interests as a novice or experienced amateur radio user. Product reviews, construction, conversions, packet radio and club news pack *HRT* from cover to cover - **This is Ham Radio - Today!** U.K. and overseas subscription rates available upon request.

Write to us or phone our subscription hotline today on: 0737 768611 and we will send every issue of *HRT* to you **post free** in the U.K!  
Argus Subscription Services, ABP, Queensway House, 2 Queensway, Redhill, Surrey RH1 1QS.

**DIRECT DELIVERY SERVICE**

**HRT** incorporating **SCANNERS**

WIN FREE FOR A YEAR

# Sunspots and the Radio Amateur

By Kurt Feldmesser, a member of the RSGB Propagation Studies Committee



OUR CENTRE-SPREAD colour poster features the effect of the sun, and in particular sunspots, on radio signals. Sunspots have been observed and recorded for three centuries, ever since Galileo (1564-1642) turned the newly invented telescope towards the sky.

In the nineteenth century Dr Rudolf Wolf of the Zurich Observatory corresponded with a number of astronomers forming a network of solar observers. This helped to maintain their records even when the weather made observation impossible in some areas.

The sunspot count tended to depend on the size of the astronomer's telescope (in other words, how big an instrument he could afford) and this resulted in some rivalry and disagreement as to the 'true' number. In order to get over this problem, Dr Wolf multiplied all counts by a factor which took telescope size into account and allowed a figure of 10 times for spot 'groups'. The system is still in use.

Among this network of observers, a German apothecary called Heinrich Samuel Schwabe made meticulous observations of the sun for the best part of twenty years and at the end of that time in 1843 announced that sunspot numbers peaked every ten years.

The effect of this announcement was electrifying. Hundreds of records of past observations were dug up and graphs plotted to see if Schwabe's findings held true. **Fig 1** shows that graph brought up to date. We now accept eleven years as the average time between peaks.

You may ask how does radio fit into all that? Well, it's like this: When Marconi transmitted his famous three dots across the Atlantic from Cornwall to Newfoundland in 1901 he proved that radio waves could do something that light

PHOTOGRAPH: SESC, BOULDER, COLORADO



A solar flare, a gigantic flame on the Sun's surface which greatly disturbs the ionosphere and affects short-wave radio signals.

waves could not - go round the curvature of the Earth. Radio amateurs some twenty years later proved that short waves were even better for that task than the long waves all the 'professionals' were using at that time. Because of this amateurs have frequency allocations throughout the short-wave spectrum.

However, one snag with short-waves soon became apparent. Short radio waves rely upon reflection in the ionosphere where the air is extremely thin. Because of this thinness the ionosphere is strongly influenced by the energy

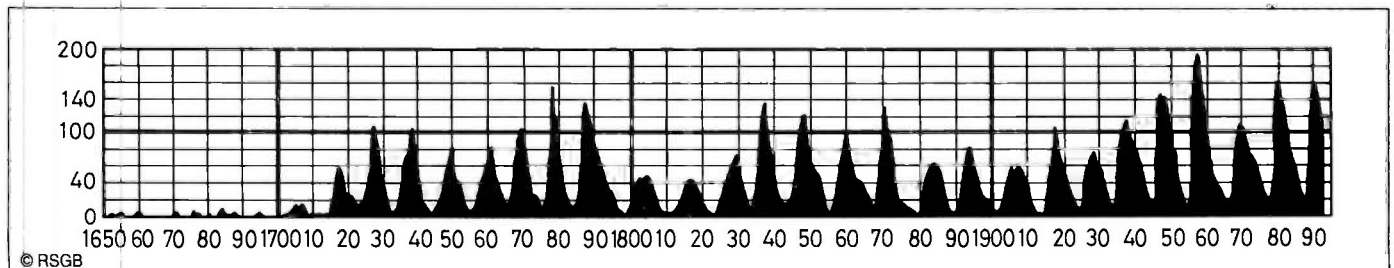

**Fig 1:** A graph of sunspot numbers for more than three hundred years: Perhaps the longest database it does allow estimates to be made of the performance of probable future solar cycles.

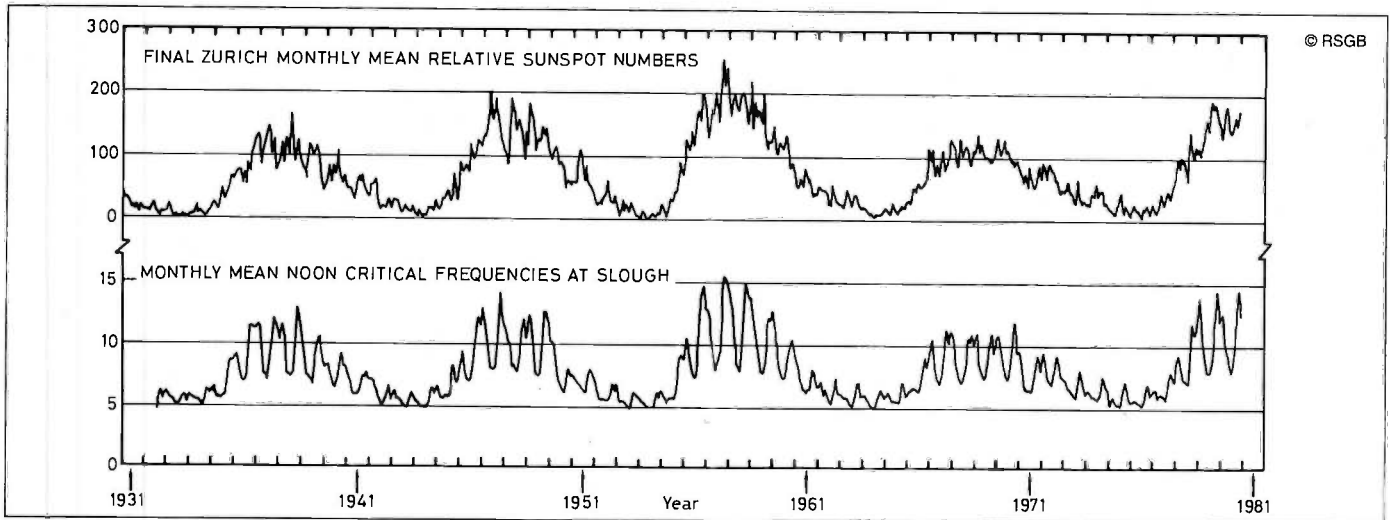

Fig 2: The usefulness of the short-wave (HF) bands (lower graph) follows closely the sunspot count (upper graph). Data from Rutherford Appleton Laboratory.

reaching it from the sun. Daylight and darkness have a great effect on this gas, and the time of year affects how much solar energy can reach the ionosphere.

Charged atomic particles ejected by the sun in the 'solar wind' can cause magnetic 'storms' in the ionosphere and high intensity ultraviolet and X-ray radiation from solar flares can totally block all short-wave communication for perhaps half an hour on the sunlit side of the Earth; this is known as a Dellinger Fade-out. Luckily, flares can also cause parts of the ionosphere temporarily to reflect signals above 100MHz which would not normally be reflected; this is an effect known as Aurora (see our cover picture).

It is not surprising that the effectiveness of the ionosphere as a 'mirror in the sky' follows the sunspot number in its eleven year cycle. Since the early thirties of this century the Ionospheric Observatory in Slough has measured the effectiveness of the ionosphere as a reflector of radio waves, measuring its height and **maximum usable frequency (MUF)**. A graph of the effectiveness of the ionosphere plotted with a graph of the sunspot number shows the close relationship (Fig 2).

PICTURE: SCIENCE MUSEUM

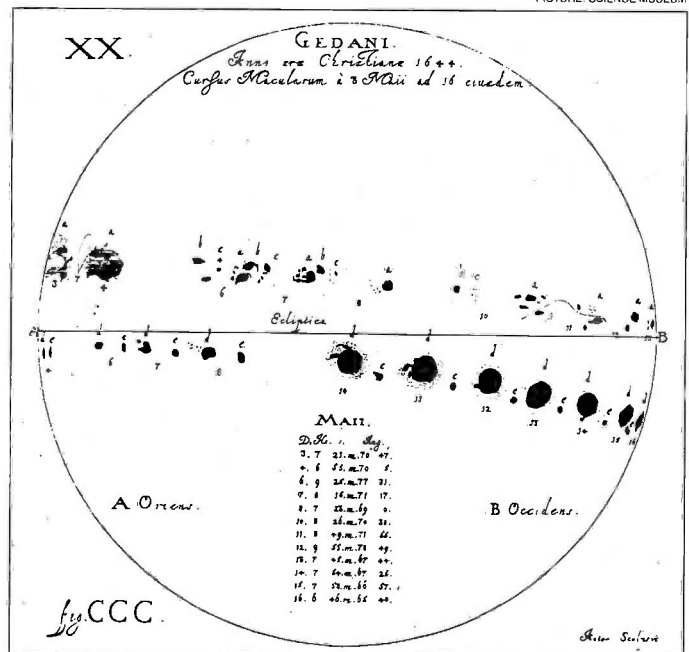

An Early Observation of the Sun. Johann Hevelius, a wealthy astronomer, constructed the best observatory of his time and made many fine observations of the sun, such as this drawing showing the positions of sunspots over several days in 1644. It took another two hundred years of observing the sun before the eleven year cycle was discovered.

## Amateur Radio and the RSGB

RADIO AMATEURS are qualified radio operators who are licensed to talk to other operators, often in distant countries, from their own homes. Amateur radio is a hobby for all ages but it is different from CB radio because a very wide variety of frequencies (wavelengths) can be used, and contacts can be in different 'modes'; by Morse code or teleprinter, between computers or even television. Many amateurs build all or part of their station equipment.

The **Radio Society of Great Britain (RSGB)** is the national society for all radio amateurs (transmitters and listeners) in this country. It has over 31,000 members, including many in overseas countries.

The Society looks after the interests of radio amateurs throughout the UK. Talks between the RSGB and the Government's Radiocommunications Agency have resulted in the popular amateur radio Novice Licence.

In particular the RSGB is keen to encourage the experimental side of electronics and radio, and the Society's monthly magazine *Radio Communication* is sent free to all members. We're having lots of fun with our hobby, so why not join us?

If you would like more information on the RSGB or the Novice Licence, write for an Information Pack to Sylvia Manco (enclosing a large stamped self-addressed envelope), at:



**RSGB, Lambda House, Cranborne Road, Potters Bar, Herts EN6 3JE.**

## Readers' Letters



Keep sending your letters and photographs to the Editor, *D-i-Y Radio*, RSGB, Lambda House, Cranborne Road, Potters Bar, Herts, EN6 3JE, and we will send a pen to the sender of each letter published.

### ENTHUSIASTIC SWL

The request for a year's subscription was brought about by the gentle but firm pressure of a colleague of my daughter. To go further back (a great deal) I have been a SWL for over 20 years, first with a Trio receiver and for the last eight years a Lowe, concentrating all my enthusiasm on the AM mode and not the side bands. Along came John, a licence holder, and suggested that I reduce my 100ft long wire to 66', and I must say that what followed was absorbing. If the conditions are right then the east coast of America is no problem. Now I am retired I have more time to enjoy the hobby.

*Ron Calver, Norfolk.*

### GOOD VALUE

*D-i-Y Radio* is a great magazine for young and old alike and I am sure that the cadets of the ATC Squadron to which I belong will love it. The back numbers are wonderful value at 50p each and so I would like all of them from the first issue.

*Eric Barton, G0RPD, Merseyside.*

[If subscribers would like to obtain back numbers of *D-i-Y Radio*, then these are 50p each. Non subscribers must pay £1.50 each for them though - *Marcia*]

### D-I-Y RADIO HELPED

I passed the Novice RAE in June, *D-i-Y Radio* helped me I'm sure, but I haven't applied for my licence yet as I would like to pass the Morse test first. I enjoyed seeing the radio circuit by Rev George Dobbs, G3RJV, as it was a TRF circuit by him that reintroduced me to short wave radio.

*Ted Barrett, South Humberside.*

### CORRECTION Sept/Oct 1993

STEVE ORTAMAYER, G4RAW, notes an error in the circuit diagram of his Tuna Checker. The output pin of the 74LS73 should be 9 and not 8 as shown. Pin 8 is not connected. Also pin 14 should also be connected to 5.1V. The PCB layout is correct.

## D-i-ar-Y M A R - A P R

### MARCH

- 5/6 ARRL SSB Contest
- 12/13 RSGB London Amateur Radio & Computer Show (see page 14)
- 12/13 RSGB Commonwealth Contest (80 - 10m CW)
- 14 Novice RAE
- 20 Norbreck Radio, Electronics and Computing Exhibition (see page 4).
- 26/27 CQ WPX SSB Contest (see *The Log Book*)

### APRIL

- 3 White Rose Rally, Allerton High School, Links Lane, Leeds. Details from G7ELS on 0850 690189.
- 5 RSGB QRS Contest (Slow Morse)
- 10 Swansea Rally, Swansea Leisure Centre. 10.30am - 5pm. Details: 0792 404422.
- 10 RSGB 1.3GHz and 2.3GHz Fixed and SWL Contests (see page 15).

## Become a regular D-i-Y'er

Get *D-i-Y Radio* for the next year\* plus

- \* An RSGB Map of Western Europe (900mm wide and 1200mm high)
- \* A plastic wallet so you can keep your issues of *D-i-Y Radio* Safe
- \* An RSGB pen and a badge

... all for the special introductory price of only £9!

RSGB Members see RadCom for details of special offer  
Overseas Subscribers write for prices.

Please let us know your age or the age of the person for whom you are buying *D-i-Y Radio* and where you saw this copy.

\* *D-i-Y Radio* is published six times a year

Send cheques or postal orders, made payable to:



RSGB, Lambda House, Cranborne Road,  
Potters Bar, Herts, EN6 3JE.

## STUDYING FOR THE NRAE OR RAE?

Revision Questions for the  
Novice RAE

**£6.00** (inc p&p)

RAE Revision Notes

**£5.00** (inc p&p)



RSGB, Lambda House, Cranborne Road,  
Potters Bar, Herts, EN6 3JE.

# DI-DI-DAH-DAH-DI-DIT

## Win a Video

WIN ONE OF THE VIDEOS REVIEWED ON PAGE 11. The winner can choose which one of the four videos featured he/she would like to receive as his/her prize. Thanks to Nevada Communications for donating this super prize.

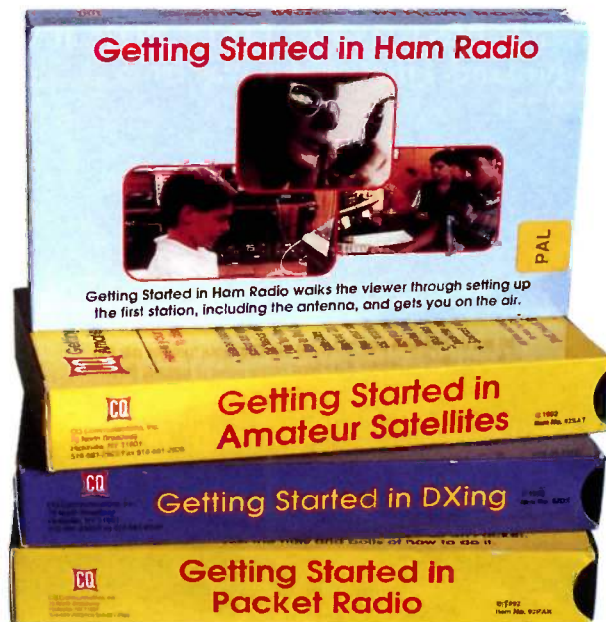

### WINNERS!

**WINNERS OF THE D-i-Y Radio Components Competition (Nov-Dec issue):**

**1st Prize:** Nigel Collierwebb from Jersey wins the Hands RX-1 80m Receiver.

**2nd Prizes:** Henrik Cederberg from Sweden and Bernard Gray from Whitstable win RSGB5WPM Morse Practice Cassettes.

**3rd Prizes:** Gareth Harmer from Dyfed and Mr P Newberry from Surrey win Mini Photo Albums.

*For information, the answers were as follows: 1C, 2B, 3A, 4B, 5B, 6A, 7B, 8A, 9B, 10A.*

- 1st Prize:** Getting Started Video
- 2nd Prizes:** Blank Video Cassettes
- 3rd Prizes:** World Prefix Maps

Some words relating to amateur radio have been jumbled up, and this issue's competition is to try and find out what the words are. All you have to do is to unscramble the words and write them in order on a postcard. Include on your postcard which video you would like to win. Send all entries to: The Editor, *D-i-Y Radio*, Cranborne Road, Potters Bar, Herts EN6 3JE by 30 April 1994 please.

Winners will be published in the July-August *D-i-Y Radio*.

### DID YOU KNOW?

*That di-di-dah-dah-di-dit at the top of the page is Morse code for a question mark?*

### SPECIAL OFFERS

Every *D-i-Y Radio* includes a special offer, indicated by the 50p coin symbol. This issue's offer appears on page 19. If you would like to save 50p off the price shown, then send in this corner token with your order. If you still have any of the old coupons left you can still use these instead, but remember - just one coupon per order.

ALOSR \_\_\_\_\_

GNOOPAPTRIA \_\_\_\_\_

PTOUSSN \_\_\_\_\_

VRREEIEC \_\_\_\_\_

DTFRAEERC \_\_\_\_\_

SMGMAEINT \_\_\_\_\_

GASLLINC \_\_\_\_\_

EFXRIP \_\_\_\_\_

IUOAD EFILMAPRI \_\_\_\_\_

SSTTAONRIR \_\_\_\_\_

BDBDRREOAA \_\_\_\_\_

TTTRRIMAESN \_\_\_\_\_



# For the very best in Communications Receivers Look to Lowe

## LOWE HF RECEIVERS DO IT AGAIN!

HF-225 voted "RECEIVER OF THE YEAR" in 1990 by W.R.T.H.,  
HF-225 "FINLANDIA" voted "BEST DX RECEIVER 1992" at  
the EDXC Convention in Finland. Final choice was from  
HF-225, NRD-535 and IC-R72E.



ONCE  
AGAIN  
THE BEST IS  
BRITISH!

## LOWE ELECTRONICS LIMITED

Chesterfield Road, Matlock, Derbyshire DE4 5LE  
Telephone: (0629) 580800 Fax: (0629) 580020

### BRANCH ADDRESSES:

London (Heathrow): 6 Cherwell Close, Langley. Tel: (0753) 545255  
Newcastle: Newcastle International Airport. Tel: (0661) 860418  
Cumbernauld: Cumbernauld Airport Foyer. Tel: (0236) 721 004  
Bristol: 79/81 Gloucester Road, Patchway, Bristol, BS12 5JQ. Tel: (0272) 315263  
Cambridge: 162 High Street, Chesterton. Tel: (0223) 311230  
Bournemouth: 27 Gillam Road, Northbourne. Tel: (0202) 577760  
Leeds: 34 New Briggate, Leeds. Tel: (0532) 452657  
Kent: Chatham Road, Sandling, Maidstone, Kent, ME14 3AY. Tel: 0622 692773  
Plymouth: The Basement, Royal Fleet Club, Devonport, Plymouth,  
Devon PL1 4PQ. Tel: 0752 607284

