

**THE NEW!**

# **Amateur 73<sup>®</sup> Radio Today**

JULY 2000  
ISSUE #476  
USA \$3.95  
CANADA \$4.95

**Antennas!**

**Antennas!**

**Antennas!**

**Antennas!**

**Review:  
Comet's CA-UHV  
(shown here)**

.....  
\*\*\*\*\*3-DIGIT 231  
#00000109389WR6# JUL76 95  
JACK SPEER 45  
BUCKMASTER PUBLISH P 4  
RTE 3 BOX 56  
MINERAL VA 23117-9803

# DR-135TP. Two Meters. Features Not Seen Before.

INTERNAL TNC FOR PACKET AND APRS®



- Choose black (DR-135TP) or pewter (DR-135TPG) front panel color
- DR-135T can be purchased without TNC; EJ-41U TNC board can be added later
- 50 watts, H/M/L power settings
- 100 memory channels
- TNC board operates 1200 and 9600 bps
- Front panel GPS input for APRS
- Rear panel DSUB9 computer connection
- No need to remove mic for packet operation
- Ignition key on/off feature
- CTCSS and DCS encode+decode
- Clean, clear Alinco audio
- Super-wide 7 character alphanumeric display
- Wide and narrow FM modes
- Theft alarm feature
- AM airband receive
- Backlit microphone
- Stays in mode you select (voice/packet) through power off cycles
- Ten autodial memories
- Low Alinco price

WWW.**ALINCO**.com

U.S.A. Alinco Branch: 438 Amapola Ave. • Suite 130 • Torrance, CA 90501

Product intended for properly licensed operators. Permits required for MARS/CAP use. Specifications subject to change without notice or obligation. Performance specifications only apply to amateur bands. APRS is a registered trademark of Bob Bruninga, WB4APR.

This radio has not yet been type accepted by the FCC. It may not be offered for sale or lease until the approval of the FCC has been obtained.

**El Supremo & Founder**  
Wayne Green W2NSD/1

**Associate Publisher**  
F. I. Marion

**Executive Editor**  
Jack Burnett

**Managing Editor**  
Joyce Sawtelle

**Technical Editor**  
Larry Antonuk WB9RRT

**Contributing Culprits**  
Mike Bryce WB8VGE  
Jim Gray W1XU/7  
Jack Heller KB7NO  
Chuck Houghton WB6IGP  
Andy MacAllister W5ACM  
Joe Moell K0OV  
Steve Nowak KE8YN/5  
Dr. Rick Olsen N6NR

**Advertising Sales**  
Evelyn Garrison WS7A  
21704 S.E. 35th St.  
Issaquah WA 98029  
425-557-9611  
Fax: 425-557-9612

**Circulation**  
Frances Hyvarinen

**Data Entry & Other Stuff**  
Norman Marion

**Business Office**  
Editorial - Advertising - Circulation  
Feedback - Product Reviews  
73 Amateur Radio Today Magazine  
70 Hancock Rd.  
Peterborough NH 03458-1107  
603-924-0058  
Fax: 603-924-8613

Reprints: \$3 per article  
Back issues: \$5 each

Printed in the USA

# THE NEW! 73 Amateur Radio Today

## TABLE OF CONTENTS

### FEATURES

- 10 **The Universal Loop — G2BZQ**  
*A novel, efficient, modularly constructed receiving loop antenna covering from 55 kHz to 40 MHz (or even more).*
- 14 **String Up the GPU 80 — G2BZQ**  
*This compact antenna could be part of your clandestiny.*
- 18 **Return of the Amazin' Hall Tree Vertical — K5CW**  
*This time for 40/30.*
- 20 **Twinleads To Go — W4JC**  
*Keep these emergency antennas for 2m and 70cm in your glovebox.*
- 22 **The Hybrid Vee — KB5IAY, W1XU/7**  
*Revisit the original Taylor Vee — and improve it.*
- 24 **Tuner King Strikes Again — Part 2 — W6WTU**  
*Make a basic VHF/UHF signal source from your TV/VCR tuner.*
- 29 **The Rocky Road to a Great Radio Club — WA6ITF**  
*An interview with Jeff Seligman WA2VNT/7.*

### REVIEW

- 34 **When They Say Multiband, They Mean It! — KE8YN/4**  
*73 reviews the Comet CA-UHV antenna.*

### DEPARTMENTS

- WB6IGP 38 Above & Beyond
- 49 Ad Index
- 64 Barter 'n' Buy
- 27 Calendar Events
- KB7NO 52 The Digital Port
- N6NR 43 The DX Forum
- W5ACM 50 Hamsats
- 8 Letters
- W2NSD/1 4 Never Say Die
- 48 New Products
- 56 On the Cover
- KE8YN/4 41 On the Go
- W1XU/7 60 Propagation
- WB8VGE 55 QRP
- 1, 6 QRX
- 63 Radio Bookshop

**E-Mail**  
design73@aol.com

**Web Page**  
www.waynegreen.com

## QRX . . .

### Techs — Only — Continue to Grow

As we enter a restructured Amateur Radio Service, it's a good time to look at some statistics. First, the good news. The number of code-free Technician-class hams being license holders continues to grow. Based on a comparison census from April of 1998, the number of No-Code Techs has increased by another 21,000. That's over 10%.

Now, the bad news. All other license classes — except the Extra — are on a rather rapid decline,

with many hams just not bothering to renew their licenses. The biggest loss is in the Novice class, where there are 11,000 fewer license holders than just two years ago.

Right now, there are about 34,323 hams in the FCC database whose licenses have expired within the past two years. Their grace period has just about run out, and there is no sign of interest in any of them renewing. In the simplest terms, when these licenses get written out of the FCC records, 5% of the currently licensed hams will be gone. Put another way,

*Continued on page 6*

**Manuscripts:** Contributions for possible publication are most welcome. We'll do the best we can to return anything you request, but we assume no responsibility for loss or damage. Payment for submitted articles will be made after publication. Please submit both a disk and a hard copy of your article [IBM (ok) or Mac (preferred) formats], carefully checked drawings and schematics, and the clearest, best focused and lighted photos you can manage. "How to write for 73" guidelines are available on request. US citizens, please include your Social Security number with submitted manuscripts so we can submit it to you know who.

**73 Amateur Radio Today** (ISSN 1052-2522) is published monthly by 73 Magazine, 70 N202, Peterborough NH 03458-1107. The entire contents ©2000 by 73 Magazine. No part of this publication may be reproduced without written permission of the publisher, which is not all that difficult to get. The subscription rate is: one year \$24.97, two years \$44.97; Canada: one year \$34.21, two years \$57.75, including postage and 7% GST. Foreign postage: \$19 surface, \$42 airmail additional per year, payable in US funds on a US bank. Second class postage is paid at Peterborough, NH, and at additional mailing offices. Canadian second class mail registration #178101. Canadian GST registration #125393314. Microfilm edition: University Microfilm, Ann Arbor MI 48106. POSTMASTER: Send address changes to 73 Amateur Radio Today, 70 Hancock Rd., Peterborough NH 03458-1107. 73 Amateur Radio Today is owned by Shabromat Way Ltd. of Hancock NH.



# ...POWER ON WITH ASTRON

SWITCHING POWER SUPPLIES...



MODEL SS-10TK



MODEL SS-12IF



MODEL SS-18



MODEL SS-25M



MODEL SRM-30



MODEL SRM-30M-2



MODEL SS-12SM/GTX



MODEL SS-10EFJ-98

### SPECIAL FEATURES:

- HIGH EFFICIENCY SWITCHING TECHNOLOGY SPECIFICALLY FILTERED FOR USE WITH COMMUNICATIONS EQUIPMENT, FOR ALL FREQUENCIES INCLUDING HF
- HEAVY DUTY DESIGN
- LOW PROFILE, LIGHT WEIGHT PACKAGE
- EMI FILTER
- MEETS FCC CLASS B

### PROTECTION FEATURES:

- CURRENT LIMITING
- OVERVOLTAGE PROTECTION
- FUSE PROTECTION
- OVER TEMPERATURE SHUTDOWN

### SPECIFICATIONS:

INPUT VOLTAGE: 115 VAC 50/60HZ  
OR 220 VAC 50/60HZ  
SWITCH SELECTABLE

OUTPUT VOLTAGE: 13.8VDC

AVAILABLE WITH THE FOLLOWING APPROVALS: UL, CUL, CE, TUV.

### DESKTOP SWITCHING POWER SUPPLIES

MODEL	CONT. (Amps)	ICS	SIZE (inches)	Wt.(lbs.)
SS-10	7	10	1 1/4 x 6 x 9	3.2
SS-12	10	12	1 1/4 x 6 x 9	3.4
SS-18	15	18	1 1/4 x 6 x 9	3.6
SS-25	20	25	2 1/4 x 7 x 9 1/4	4.2
SS-30	25	30	3 1/4 x 7 x 9 1/4	5.0

### DESKTOP SWITCHING POWER SUPPLIES WITH VOLT AND AMP METERS

MODEL	CONT. (Amps)	ICS	SIZE (inches)	Wt.(lbs.)
SS-25M*	20	25	2 1/4 x 7 x 9 1/4	4.2
SS-30M*	25	30	3 1/4 x 7 x 9 1/4	5.0

### RACKMOUNT SWITCHING POWER SUPPLIES

MODEL	CONT. (Amps)	ICS	SIZE (inches)	Wt.(lbs.)
SRM-25	20	25	3 1/4 x 19 x 9 1/4	6.5
SRM-30	25	30	3 1/4 x 19 x 9 1/4	7.0

### WITH SEPARATE VOLT & AMP METERS

MODEL	CONT. (Amps)	ICS	SIZE (inches)	Wt.(lbs.)
SRM-25M	20	25	3 1/4 x 19 x 9 1/4	6.5
SRM-30M	25	30	3 1/4 x 19 x 9 1/4	7.0

### 2 ea SWITCHING POWER SUPPLIES ON ONE RACK PANEL

MODEL	CONT. (Amps)	ICS	SIZE (inches)	Wt.(lbs.)
SRM-25-2	20	25	3 1/4 x 19 x 9 1/4	10.5
SRM-30-2	25	30	3 1/4 x 19 x 9 1/4	11.0

### WITH SEPARATE VOLT & AMP METERS

MODEL	CONT. (Amps)	ICS	SIZE (inches)	Wt.(lbs.)
SRM-25M-2	20	25	3 1/4 x 19 x 9 1/4	10.5
SRM-30M-2	25	30	3 1/4 x 19 x 9 1/4	11.0

### CUSTOM POWER SUPPLIES FOR RADIOS BELOW

EF JOHNSON AVENGER GX-MC41  
EF JOHNSON AVENGER GX-MC42  
EF JOHNSON GT-ML81  
EF JOHNSON GT-ML83  
EF JOHNSON 9800 SERIES  
GE MARC SERIES  
GE MONOGRAM SERIES & MAXON SM-4000 SERIES  
ICOM IC-F11020 & IC-F2020  
KENWOOD TK760, 762, 840, 860, 940, 941  
KENWOOD TK760H, 762H  
MOTOROLA LOW POWER SM50, SM120, & GTX  
MOTOROLA HIGH POWER SM50, SM120, & GTX  
MOTOROLA RADIUS & GM 300  
MOTOROLA RADIUS & GM 300  
MOTOROLA RADIUS & GM 300  
UNIDEN SMH1525, SMU4525  
VERTEX — FTL-1011, FT-1011, FT-2011, FT-7011

### NEW SWITCHING MODELS

SS-10GX, SS-12GX  
SS-18GX  
SS-12EFJ  
SS-18EFJ  
SS-10-EFJ-98, SS-12-EFJ-98, SS-18-EFJ-98  
SS-12MC  
SS-10MG, SS-12MG  
SS-101F, SS-121F  
SS-10TK  
SS-12TK OR SS-18TK  
SS-10SM/GTX  
SS-10SM/GTX, SS-12SM/GTX, SS-18SM/GTX  
SS-10RA  
SS-12RA  
SS-18RA  
SS-10SMU, SS-12SMU, SS-18SMU  
SS-10V, SS-12V, SS-18V

# RAMSEY

## Doppler Direction Finder



Track down jammers and hidden transmitters with ease! This is the famous WA2EBY DF'er featured in April 99 QST. Shows direct bearing to transmitter on compass style LED display, easy to hook up to any FM receiver. The transmitter - the object of your DF'ing - need not be FM, it can be AM, FM or CW. Easily connects to receiver's speaker jack and antenna, unit runs on 12 VDC. We even include 4 handy home-brew "mag mount" antennas and cable for quick set up and operation! Whips can be cut and optimized for any frequency from 130-1000 MHz. Track down that jammer, win that fox hunt, zero in on that downed Cessna - this is an easy to build, reliable kit that compares most favorably to commercial units costing upwards of \$1000.00! This is a neat kit!!

DDF-1, Doppler Direction Finder Kit ..... \$149.95

## Wireless RF Data Link Modules

RF link boards are perfect for any wireless control application; alarms, data transmission, electronic monitoring...you name it. Very stable SAW resonator transmitter, crystal controlled receiver - no frequency drift! Range up to 600 feet, license free 433 MHz band. Encoder/decoder units have 12 bit Holtek HT-12 series chips allowing multiple units all individually addressable, see web site for full details. Super small size - that's a quarter in the picture! Run on 3-12 VDC. Fully wired and tested, ready to go and easy to use!

RX-433 Data Receiver..... \$16.95 TX-433 Data Transmitter..... \$14.95  
 RXD-433 Receiver/Decoder..... \$21.95 TXE-433 Transmitter/Encoder..... \$19.95

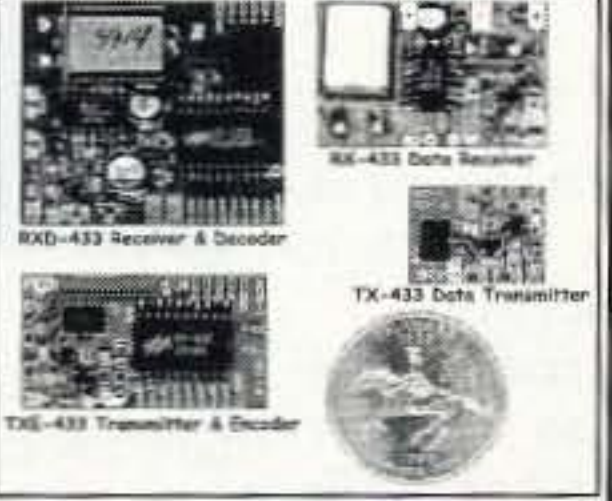

## World's Smallest TV Transmitters



We call them the 'Cubes'.... Perfect video transmission from a transmitter you can hide under a quarter and only as thick as a stack of four pennies - that's a nickel in the picture! Transmits color or B&W with fantastic quality - almost like a direct wired connection to any TV tuned to cable channel 59. Crystal controlled for no frequency drift with performance that equals models that cost hundreds more! Basic 20 mW model transmits up to 300' while the high power 100 mW unit goes up to 1/4 mile. Their very light weight and size make them ideal for balloon and rocket launches, R/C models, robots - you name it! Units run on 9 volts and hook-up to most any CCD camera or standard video source. In fact, all of our cameras have been tested to mate perfectly with our Cubes and work great. Fully assembled - just hook-up power and you're on the air! One customer even put one on his dog!

C-2000, Basic Video Transmitter.....\$89.95 C-2001, High Power Video Transmitter....\$179.95

## CCD Video Cameras

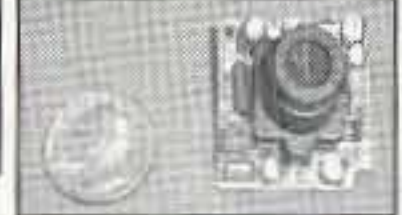

Top quality Japanese Class 'A' CCD array, over 440 line line resolution, not the off-spec arrays that are found on many other cameras. Don't be fooled by the cheap CMOS single chip cameras which have 1/2 the resolution, 1/4 the light sensitivity and draw over twice the current! The black & white models are also super IR (Infra-Red) sensitive. Add our invisible to the eye, IR-1 illuminator kit to see in the dark! Color camera has Auto gain, white balance, Back Light Compensation and DSP! Available with Wide-angle (80°) or super slim Pin-hole style lens. Run on 9 VDC, standard 1 volt p-p video. Use our transmitters for wireless transmission to TV set, or add our IB-1 interface board kit for super easy direct wire hook-up to any Video monitor, VCR or TV with A/V input. Fully assembled, with pre-wired connector.

- CCDWA-2, B&W CCD Camera, wide-angle lens ..... \$69.95
- CCDPH-2, B&W CCD Camera, slim fit pin-hole lens. . \$69.95
- CCDCC-1, Color CCD Camera, wide-angle lens .... \$129.95
- IR-1, IR Illuminator Kit for B&W cameras ..... \$24.95
- IB-1, Interface Board Kit ..... \$14.95

## AM Radio Transmitter



Operates in standard AM broadcast band. Pro version, AM-25, is synthesized for stable, no-drift frequency and is settable for high power output where regulations allow, typical range of 1-2 miles. Entry-level AM-1 is tunable, runs FCC maximum 100 mW, range 1/4 mile. Both accept line-level inputs from tape decks, CD players or mike mixers, run on 12 volts DC. Pro AM-25 includes AC power adapter, matching case and bottom loaded wire antenna. Entry-level AM-1 has an available matching case and knob set that dresses up the unit. Great sound, easy to build - you can be on the air in an evening!

AM-25, Professional AM Transmitter Kit. .... \$129.95  
 AM-1, Entry level AM Radio Transmitter Kit. . \$29.95  
 CAM, Matching Case Set for AM-1..... \$14.95

## Mini Radio Receivers



Imagine the fun of tuning into aircraft a hundred miles away, the local police/fire department, ham operators, or how about Radio Moscow or the BBC in London? Now imagine doing this on a little radio you built yourself - in just an evening! These popular little receivers are the nuts for catching all the action on the local ham, aircraft, standard FM broadcast radio, shortwave or WWV National Time Standard radio bands. Pick the receiver of your choice, each easy to build, sensitive receiver has plenty of crystal clear audio to drive any speaker or earphone. Easy one evening assembly, run on 9 volt battery, all have squelch except for shortwave and FM broadcast receiver which has subcarrier output for hook-up to our SCA adapter. The SCA-1 will tune in commercial-free music and other "hidden" special services when connected to FM receiver. Add our snazzy matching case and knob set for that smart finished look!

AR-1, Airband 108-136 MHz Kit. .... \$29.95  
 HFR-1, WWV 10 MHz (crystal controlled) Kit. .... \$34.95  
 FR-1, FM Broadcast Band 88-108 MHz Kit ..... \$24.95  
 SR-1, Shortwave 4-11 MHz Band Kit ..... \$29.95  
 SCA-1 SCA Subcarrier Adapter kit for FM radio. . \$27.95  
 FR-6, 6 Meter FM Ham Band Kit ..... \$34.95  
 FR-10, 10 Meter FM Ham Band Kit ..... \$34.95  
 FR-146, 2 Meter FM Ham Band Kit. .... \$34.95  
 FR-220, 220 MHz FM Ham Band Kit. .... \$34.95  
 Matching Case Set (specify for which kit) .... \$14.95

## PIC-Pro Pic Chip Programmer



Easy to use programmer for the PIC16C84, 16F84, 16F83 microcontrollers by Microchip. All software - editor, assembler, run and program - as well as free updates available on Ramsey download site! This is the popular unit designed by Michael Covington and featured in Electronics Now, September 1998. Connects to your parallel port and includes the great looking matching case, knob set and AC power supply. Start programming those really neat microcontrollers now...order your PICPRO today!

PIC-1, PICPRO PIC Chip Programmer Kit ..... \$59.95

**Order Toll-free: 800-446-2295**  
 Sorry, no tech info, or order status at 800 number  
**For Technical Info, Order Status**  
**Call Factory direct: 716-924-4560**

**RAMSEY ELECTRONICS, INC.**  
 793 Canning Parkway Victor, NY 14564  
 See our complete catalog and order on-line with our secure server at:  
**www.ramseyelectronics.com**

## 1 GHz RF Signal Generator



A super price on a full featured RF signal generator! Covers 100 KHz to 999.99999 MHz in 10 Hz steps. Tons of features; calibrated AM and FM modulation, 90 front panel memories, built-in RS-232 interface, +10 to -130 dBm output and more! Fast and easy to use, its big bright vacuum florescent display can be read from anywhere on the bench and the handy 'smart-knob' has great analog feel and is intelligently enabled when entering or changing parameters in any field - a real time saver! All functions can be continuously varied without the need for a shift or second function key. In short, this is the generator you'll want on your bench, you won't find a harder working RF signal generator - and you'll save almost \$3,000 over competitive units!

RSG-1000B RF Signal Generator ..... \$1995.00

## Super Pro FM Stereo Transmitter



Professional synthesized FM Stereo station in easy to use, handsome cabinet. Most radio stations require a whole equipment rack to hold all the features we've packed into the FM-100. Set freq with Up/Down buttons, big LED display. Input low pass filter gives great sound (no more squeals or swishing from cheap CD inputs!) Limiters for max 'punch' in audio - without over mod, LED meters to easily set audio levels, built-in mixer with mike, line level inputs. Churches, drive-ins, schools, colleges find the FM-100 the answer to their transmitting needs, you will too. Great features, great price! Kit includes cabinet, whip antenna, 120 VAC supply. We also offer a high power export version of the FM-100 fully assembled with one watt of RF power, for miles of program coverage. The export version can only be shipped if accompanied by a signed statement that the unit will be exported.

FM-100, Pro FM Stereo Transmitter Kit ..... \$249.95  
 FM-100WT, Fully Wired High Power FM-100. .... \$399.95

## FM Stereo Radio Transmitters



No drift, microprocessor synthesized! Great audio quality, connect to CD player, tape deck or mike mixer and you're on-the-air. Strapable for high or low power! Runs on 12 VDC or 120 VAC. Kit includes snazzy case, whip antenna, 120 VAC power adapter - easy one evening assembly.

FM-25, Synthesized Stereo Transmitter Kit ..... \$129.95

Lower cost alternative to our high performance transmitters. Great value, easily tunable, fun to build. Manual goes into great detail about antennas, range and FCC rules. Handy for sending music thru house and yard, ideal for school projects too - you'll be amazed at the exceptional audio quality! Runs on 9V battery or 5 to 15 VDC. Add matching case and whip antenna set for nice 'pro' look.

FM-10A, Tunable FM Stereo Transmitter Kit. .... \$34.95  
 CFM, Matching Case and Antenna Set ..... \$14.95  
 FMAC, 12 Volt DC Wall Plug Adapter..... \$9.95

## RF Power Booster



Add muscle to your signal, boost power up to 1 watt over a freq range of 100 KHz to over 1000 MHz! Use as a lab amp for signal generators, plus many foreign users employ the LPA-1 to boost the power of their FM transmitters, providing radio service through an entire town. Runs on 12 VDC. For a neat finished look, add the nice matching case set. Outdoor unit attaches right at the antenna for best signal - receiving or transmitting, weatherproof, too!

LPA-1, Power Booster Amplifier Kit ..... \$39.95  
 CLPA, Matching Case Set for LPA-1 Kit ..... \$14.95  
 LPA-1WT, Fully Wired LPA-1 with Case ..... \$99.95  
 FMBA-1, Outdoor Mast Mount Version of LPA-1 ..... \$59.95

## FM Station Antennas

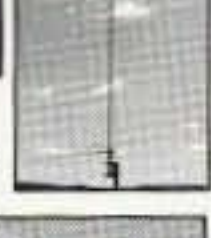

For maximum performance, a good antenna is needed. Choose our very popular dipole kit or the Comet, a factory made 5/8 wave colinear model with 3.4 dB gain. Both work great with any FM receiver or transmitter.

TM-100, FM Antenna Kit ..... \$39.95  
 FMA-200, Vertical Antenna ..... \$114.95

**VISA** **MasterCard** **AMERICAN EXPRESS** **DISCOVER**

**ORDERING INFO:** Satisfaction Guaranteed. Examine for 10 days, if not pleased, return in original form for refund. Add \$6.95 for shipping, handling and insurance. Orders under \$20, add \$3.00. NY residents add 7% sales tax. Sorry, no CODs. Foreign orders, add 20% for surface mail or use credit card and specify shipping method.

# NEVER SAY DIE

Wayne Green W2NSD/1

w2nsd@aol.com  
www.waynegrain.com

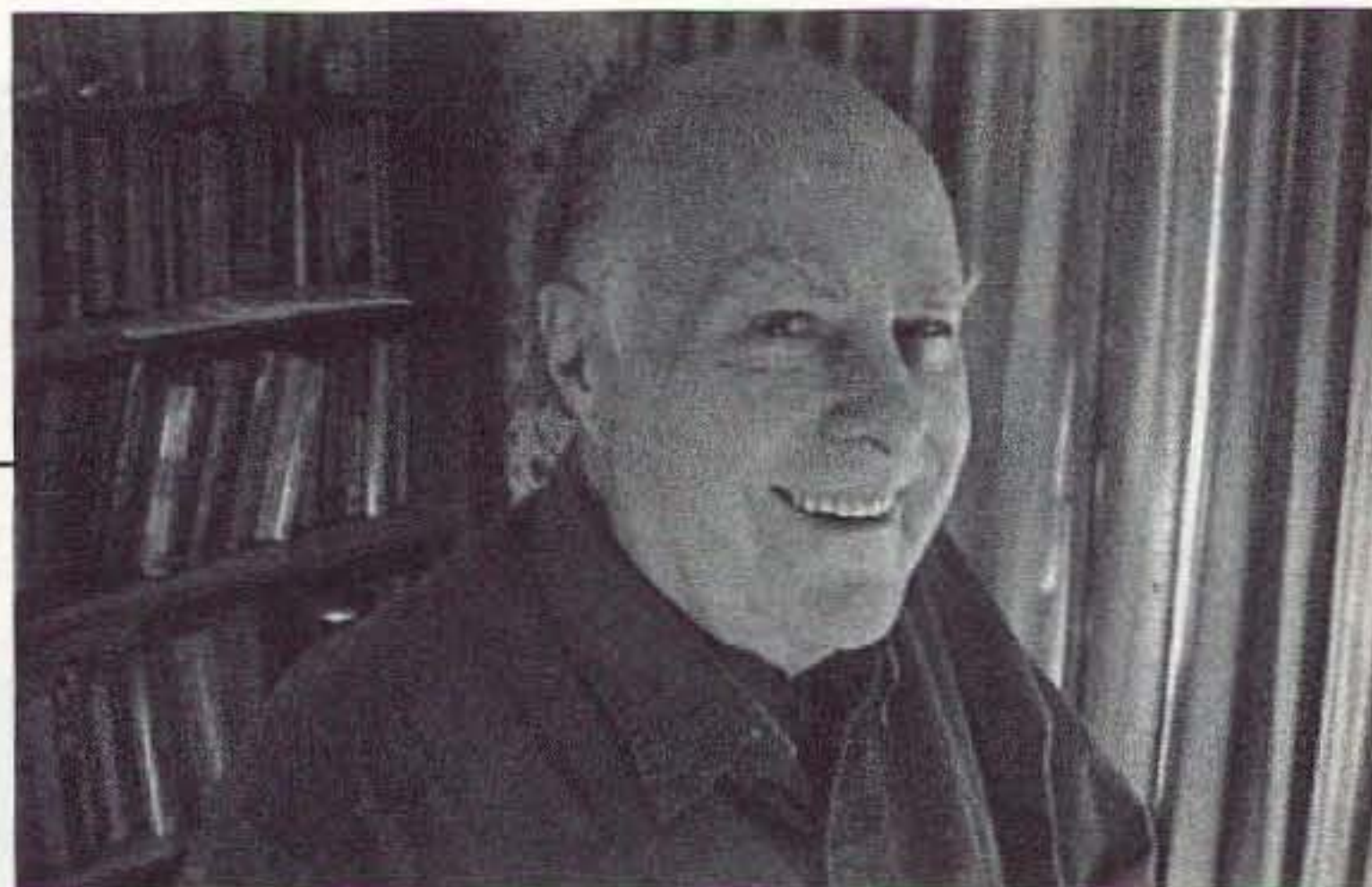

## Progress?

What's the opposite of progress? Congress?

## Club Building

Talk about making an omelet out of broken eggs, you're going to love this story — and I have George Richardson K6HOZ of the Santa Barbara Amateur Radio Club to thank for both my recent painful experience and a great idea that is going to help you build your ham club membership.

The Santa Barbara club was celebrating their 80th year (are there any older ham clubs?), so they went berserk and sent me a ticket to come out and give a talk. I reported to United Airlines — no, it was United — an hour before departure time at the Manchester (NH) airport. It took almost the hour on line to get to the check-in counter, so I went from there and boarded the plane. And sat. Knowing that for some weird reason my connecting flight to Los Angeles was only 29 minutes after my scheduled arrival in Chicago, I managed a twenty point rise in blood pressure as we sat there at the Manchester terminal for a half hour. Lousy weather in Chicago.

We arrived late, so naturally my connecting flight had already left. I got on a later plane — and we sat there for eight hours before they announced that the flight was canceled. Further, they announced, all the flights the next day were fully booked. So I gave up and went back to Manchester. That's a thumbnail sketch; for the full gory details, which I think you'll enjoy, you'll have to go to my Web site, [www.waynegrain.com].

Now comes the good part.

George, possibly infected by my Never Say Die attitude, hooked up an amplifier to the telephone and I did my talk over

the phone, much to the delight of the club members and their guests. It worked out great!

Okay, how about you hooking up a telephone to an amplifier and inviting the top ham VIPs to give a talk at your club meetings? Even the smallest ham clubs could have top name guest speakers at every meeting that way! And that'll bring new members out of the woodwork.

I'll tell you what. I'll start calling some of the experts I know and see if they're interested in such a program. Those that are I'll list, along with how to get in touch with them.

But I need your help, too. Just because someone is a name in the ham industry or an expert in some facet of the hobby doesn't mean they're going to be a great speaker, so after every guest speaker I want you to poll your club members and give me a figure on how interesting they were, from one to ten. And, as the votes come in, I'll be putting a star besides the names of the guests who get top honors as speakers.

In addition to manufacturers, some of our better known retailers, DXpeditioners, and other ham experts, we can do worse than have some other interesting guests — like some of the authors of books I've reviewed in my editorials or are reviewed in my *Secret Guide to Wisdom*. Club meetings could get to be a lot like mini versions of the old Art Bell W6OBB Coast-To-Coast AM radio show.

Heck, when I give talks I can talk about hamming as it was in the 1930s, when I got started — the beginnings of RTTY; how NBFM got started; why SSB edged out DSB, which was a superior technology; the day Khrushchev saved amateur radio; the greatest disaster in the history of the hobby; the excitement and adventure amateur radio has brought me; and so on.

Plus, given any opportunity, I talk about health, wealth, and wisdom — the Amelia Earhart mystery and cover-up — and so on. All those things I write about.

Would your club be interested in hearing my friend Neil Slade explain how you can make a cloud disappear just by thinking about it? Or does it have to be a ham topic? How about Jim Patterson talking about his cold fusion experiments and patents? Or Bev Jaegers explaining how you can develop your psychic ability? How about Ross Adey K6UI, the world's leading researcher in the effects of RF on our brains? Or Gordon Scallion K1BWC talking about his disaster predictions for the near future?

## The Next Step

Obviously, we need to take the next step and go full video for our guests. Well, the technology is already here to do this via the Internet, so let's see some articles I can publish on how to go about doing it. Also, we need some hints on how to get the best voice quality from an amplified telephone talk. I have a high quality phone and a special low noise phone line I use for my radio talk show interviews.

With interesting guest speakers at every meeting, you'll be able to build up your club membership. When I took over the Peterborough Chamber of Commerce as president, the dull meetings had reduced the attendance to about six or seven. I invited great guest speakers and a year later we had over a hundred at every meeting. When you're the president of a club, you're in show business. Do away with those business meetings. Let an executive committee do that nonsense.

Get a phone amplifier system hooked up and get busy recruiting great speakers. Then rate 'em for me so I can get the word to other clubs.

## The Pioneer

Yes, of course I'm available for talks. Get your system working, sign up on my dance card, and let me know how much time I'll have to talk and what subjects you'd prefer me to talk about. Okay, I'll put a suggested list of topics on my Web site. You can reach me via [w2nsd@aol.com], or via fax at (603) 588-3205. Please don't call — because I tend to talk too much for my (and your) good. The snail is okay, too.

Yes, of course I'll be glad to answer questions from the audience.

## Dominoes

The FCC's five-words-per-minute slap in the ARRL's face is echoing around the world. Britain, formerly known as Great Britain, quickly followed their lost colony's lead. Sweden and South Africa, too. And we'll soon be seeing Australia, New Zealand, Germany, Netherlands, Canada, Norway, Finland, Pakistan, India, Israel, and the rest of the world falling into line.

With the five-word-per-minute code requirement growing to be the world standard for HF ham band use, and with the use of CW continuing to fade away on our bands, there will be more and more pressure for the expansion of our phone bands.

The demand for my ridiculously overpriced \$5 One-Hour Morse Code booklet has escalated. This booklet explains how I learned the code well enough

Continued on page 56

# Big Savings on Radio Scanners

## COMMUNICATIONS ELECTRONICS INC.

**Order on-line and get big savings**  
Take advantage of Communications Electronics special savings when you enter your order directly on the internet. Visit CEI at <http://www.usascan.com>, and click on "CEI News" to get your big CEI E-Value savings. Resellers, get extra special pricing when you fax your sales tax license to CEI at +1-734-663-8888.

**DISTRIBUTOR'S COUPON** EXPIRES 10/30/00 #00067M

**SAVE \$30** on MPV32 or RH256N

Save \$30 when you purchase your RELM MPV32 or RH256N transceiver directly from Communications Electronics Inc., PO Box 1045, Ann Arbor MI 48106 USA. Telephone orders accepted. Call 1-800-USA-SCAN. Mention offer CEIM. TERMS: Good only in USA & Canada. Only one coupon is redeemable per purchase and only on specified product.

### NEW! RELM® MPV32-A Transceiver

Mfg. suggested list price \$515.00/Special \$299.95

Looking for a great hand-held two-way transceiver? Fire departments depend on the RELM MPV32 transceiver for direct two-way communications with their fire or police department, civil defense agency or ham radio repeater. The MPV32 is our most popular programmable frequency agile five watt, 32 channel handheld transceiver that has built-in CTCSS. This feature may be programmed for any 50 standard EIA tones. Frequency range 136.000 to 174.000 MHz. The full function, DTMF compatible keypad also allows for DTMF Encode/Decode and programmable ANI. Weighing only 15.5 oz., it features programmable synthesized frequencies either simplex or half duplex in 2.5 KHz. increments. Other features include PC programming and cloning capabilities, scan list, priority channel, selectable scan delay, selectable 5 watt/1 watt power levels, liquid crystal display, time-out timer and much more. When you order the MPV32 from CEI, you'll get a complete package deal including antenna, 700 ma battery (add \$20.00 to substitute a 1000 ma battery), battery charger, belt clip and user operating instructions. Other useful accessories are available. A heavy duty leather carrying case with swivel belt loop part #LCMP is \$49.95; rapid charge battery charger, part #BCMP is \$69.95; speaker/microphone, part #SMMP is \$54.95; extra high capacity 1000 ma. ni-cad battery pack, part #BPMP1 is \$79.95; extra 700 ma. ni-cad battery pack, part #BPMP7 is \$59.95; cloning cable part #CCMP is \$34.95; PC programming kit, part #PCKIT030 is \$224.95. A UHF version with a frequency range of 450-480 MHz. part #MPU32 is on special for \$299.95. Your RELM radio transceiver is ideal for many different applications since it can be programmed with just a screwdriver and programming instructions in less than 10 minutes. Programming is even faster with the optional PC kit. The programming instructions part #PIMPV is \$19.00. Call 1-800-USA-SCAN to order for RELM radios.

**Bearcat® 895XLT-A1 Radio Scanner**  
Mfg. suggested list price \$729.95/Special \$194.95  
300 Channels • 10 banks • Built-in CTCSS • S Meter  
Size: 10-1/2" Wide x 7-1/2" Deep x 3-3/8" High  
Frequency Coverage: 29,000-54,000 MHz., 108,000-174 MHz., 216,000-512,000 MHz., 806,000-823,995 MHz., 849,0125-868,995 MHz., 894,0125-956,000 MHz.

The Bearcat 895XLT is superb for intercepting trunked communications transmissions with features like TurboScan™ to search VHF channels at 100 steps per second. This base and mobile scanner is also ideal for intelligence professionals because it has a Signal Strength Meter, RS232C Port to allow computer-control of your scanner via optional hardware and 30 trunking channel indicator annunciators to show you real-time trunking activity for an entire trunking system. Other features include **Auto Store** - Automatically stores all active frequencies within the specified bank(s). **Auto Recording** - This feature lets you record channel activity from the scanner onto a tape recorder. **CTCSS Tone Board (Continuous Tone Control Squelch System)** which allows the squelch to be broken during scanning only when a correct CTCSS tone is received. For maximum scanning enjoyment, order the following optional accessories: **PS001** Cigarette lighter power cord \$14.95; **PS002** DC power cord - enables permanent operation from your vehicle's fuse box \$14.95; **MB001** Mobile mounting bracket \$14.95; **EX711** External speaker with mounting bracket & ten feet of cable with plug attached \$19.95. The BC895XLT comes with AC adapter, telescopic antenna, owner's manual and one year limited Uniden factory warranty. Not compatible with AGEIS, ASTRO, EDACS, ESAS or LTR systems. Call 1-800-USA-SCAN.

## TrunkTracking Radio

**DISTRIBUTOR'S COUPON** EXPIRES 10/30/00 #000772

**SAVE \$75** on one BC245XLT

Save \$75 when you purchase your Bearcat 245XLT handheld scanner directly from Communications Electronics Inc., PO Box 1045, Ann Arbor MI 48106 USA. Telephone orders accepted. Call 1-800-USA-SCAN. Mention offer CEI2. TERMS: Good only in USA & Canada. Only one coupon is redeemable per purchase and only on specified product.

### Bearcat® 245XLT-A TrunkTracker

Mfg. suggested list price \$429.95/CEI price \$269.95  
300 Channels • 10 banks • Trunk Scan and Scan Lists  
Trunk Lockout • Trunk Delay • Cloning Capability  
10 Priority Channels • Programmed Service Search  
Size: 2-1/2" Wide x 1-3/4" Deep x 6" High  
Frequency Coverage: 29,000-54,000 MHz., 108-174 MHz., 406-512 MHz., 806-823,995 MHz., 849,0125-868,995 MHz., 894,0125-956,000 MHz.

Our new Bearcat TrunkTracker BC245XLT, is the world's first scanner designed to track Motorola Type I, Type II, Hybrid, SMARTNET, PRIVACY PLUS and EDACS® analog trunking systems on any band. Now, follow UHF High Band, UHF 800/900 MHz trunked public safety and public service systems just as if conventional two-way communications were used. Our scanner offers many new benefits such as **Multi-Track** - Track more than one trunking system at a time and scan conventional and trunked systems at the same time. **300 Channels** - Program one frequency into each channel. **12 Bands, 10 Banks** - Includes 12 bands, with Aircraft and 800 MHz. 10 banks with 30 channels each are useful for storing similar frequencies to maintain faster scanning cycles or for storing all the frequencies of a trunked system. **Smart Scanner** - Automatically program your BC245XLT with all the frequencies and trunking talk groups for your local area by accessing the Bearcat national database with your PC. If you do not have a PC simply use an external modem. **Turbo Search** - Increases the search speed to 300 steps per second when monitoring frequency bands with 5 KHz. steps. **10 Priority Channels** - You can assign one priority channel in each bank. Assigning a priority channel allows you to keep track of activity on your most important channels while monitoring other channels for transmissions. **Preprogrammed Service (SVC) Search** - Allows you to toggle through preprogrammed police, fire/emergency, railroad, aircraft, marine, and weather frequencies. **Unique Data Skip** - Allows your scanner to skip unwanted data transmissions and reduces unwanted birdies. **Memory Backup** - If the battery completely discharges or if power is disconnected, the frequencies programmed in your scanner are retained in memory. **Manual Channel Access** - Go directly to any channel. **LCD Back Light** - An LCD light remains on for 15 seconds when the back light key is pressed. **Autolight** - Automatically turns the backlight on when your scanner stops on a transmission. **Battery Save** - In manual mode, the BC245XLT automatically reduces its power requirements to extend the battery's charge. **Attenuator** - Reduces the signal strength to help prevent signal overload. The BC245XLT also works as a conventional scanner. Now it's easy to continuously monitor many radio conversations even though the message is switching frequencies. The BC245XLT comes with AC adapter, one rechargeable long life ni-cad battery pack, belt clip, flexible rubber antenna, earphone, RS232C cable, Trunk Tracker frequency guide, owner's manual and one year limited Uniden warranty. Not compatible with AGEIS, ASTRO, ESAS or LTR systems. Hear more action on your radio scanner today. Call CEI today at 1-800-USA-SCAN to order your BC245XLT radio scanner.

## Radio Scanners

- AOR8200B-A wideband handheld scanner/SPECIAL ..... \$519.95
- AOR5000B+3-A wideband communications receiver ..... \$2,089.95
- AOR3000A-A wideband base/mobile scanner/SPECIAL ... \$1,049.95
- AOR AR16BQ wideband handheld scanner w/ quick charge \$209.95
- Bearcat 895XLT-A1 300 ch. TrunkTracker base scanner ..... \$194.95
- Bearcat 780XLT Reserve yours now at <http://www.usascan.com>
- Bearcat 278CLT-A 100 ch base AM/FM/SAME WX alert ..... \$169.95
- Bearcat 248CLT-A 50 ch. base AM/FM/weather alert scanner \$99.95
- Bearcat 245XLT-A 300 channel TrunkTracker II scanner ..... \$269.95
- Bearcat Sportcat 200 alpha handheld sports scanner ..... \$174.95
- Bearcat Sportcat 180B handheld sports scanner ..... \$149.95
- Bearcat 80XLT-A3 50 channel handheld scanner ..... \$104.95
- Bearcat 60XLT1-A 30 channel handheld scanner ..... \$79.95
- Bearcat BC77-A information mobile scanner ..... \$149.95
- ICOM ICR8500-A2 wideband communications receiver .... \$1,479.95
- ICOM PCR1000-A2 computer communications scanner ..... \$329.95
- ICOM ICR75-A2 communications receiver ..... \$664.95
- ICOM R10-A2 handheld wideband communications receiver \$289.95

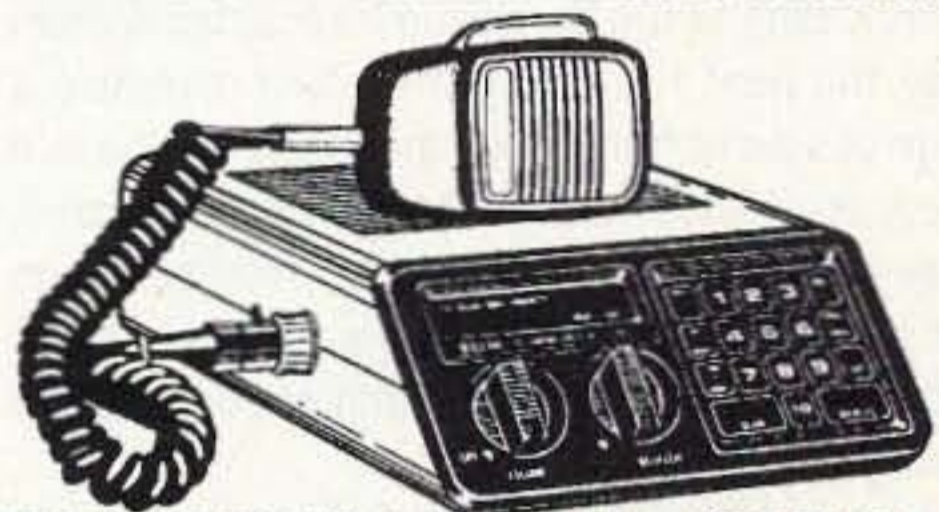

### RELM® RH256N-A Transceiver/SPECIAL

Mfg. suggested list price \$460.00/Special \$284.95  
Size: 6-1/2" Wide x 10-3/4" Deep x 2-3/4" High  
Frequency Coverage: 144,000-174,000 MHz.

Now...everyone can have their own RELM two-way transceiver and stay in touch with their department. The RELM RH256N is a powerful 25 Watt scanning transceiver that is perfect for law enforcement, fire and urban search and rescue agencies. The RH256N is programmable for up to sixteen different frequencies with selectable CTCSS tones on each channel. Also includes simplex and repeater capability, scan delay and time-out timer. Built-in priority scanner is selectable from the slope-front panel. When you order the RH256N from CEI, you'll get a complete package deal including microphone, vehicle mounting bracket, DC power cords and RELM's two year limited warranty. You can also use the RH256N as a base station if you order our 22 amp 12 Volt DC power supply part #PS26KX for \$94.95 and \$25.00 shipping. VHF transmitting antenna with PL259 connector part #ANTK is \$29.95. Programming instructions part #PI256 is \$19.00.

## Buy with confidence

It's easy to order from us. **Mail orders to:** Communications Electronics Inc., P.O. Box 1045, Ann Arbor, Michigan 48106 USA. Add \$20.00 per weather station or radio product for UPS ground shipping, handling and insurance to the continental USA unless otherwise stated. Add \$13.00 shipping for all accessories and publications. Add \$13.00 shipping per antenna. For Canada, Puerto Rico, Hawaii, Alaska, Guam, P.O. Box or APO/FPO delivery, shipping charges are two times continental US rates. Michigan residents add state sales tax. No COD's. Satisfaction guaranteed or return item in unused condition in original packaging within 61 days for refund, less shipping charges. 10% surcharge for net 10 billing to qualified accounts. All sales are subject to availability, acceptance and verification. Prices, terms and specifications are subject to change without notice. We welcome your Discover, Visa, American Express, MasterCard, IMPAC or Eurocard. Call anytime 1-800-USA-SCAN or 800-872-7226 to order toll-free. Call 734-996-8888 if outside Canada or the USA. FAX anytime, dial 734-663-8888. Dealer and international inquiries invited. Order from Communications Electronics Inc. today and save.

Price schedule effective July 2, 2000 AD #07020073 ©2000 Communications Electronics Inc.

**For credit card orders call 1-800-USA-SCAN**  
**Communications Electronics Inc.**  
**Emergency Operations Center**  
e-mail: [cei@usascan.com](mailto:cei@usascan.com)  
[www.usascan.com](http://www.usascan.com)  
PO Box 1045, Ann Arbor, Michigan 48106-1045 USA  
For information call 734-996-8888 or FAX 734-663-8888

## WX/VHF/CB Radios

Have fun and use our CB, shortwave and commercial radios to keep in touch with the world, friends and family.

- Cobra 148GTL-A3 SSB CB/SPECIAL ..... \$114.95
- Maxon HCB40WX handheld CB with 10 weather ch. .... \$69.95
- Davis 7440CS-A Complete weather station ..... \$419.95
- RELM SMV4099W-A 40 watt VHF mobile transceiver .. \$349.95
- Uniden GRANTXL-A SSB CB Mobile ..... \$124.95
- Sangean ATS909-A shortwave receiver ..... \$229.95
- Sangean ATS818CS-A shortwave receiver ..... \$199.95
- Sangean ATS404-A shortwave receiver ..... \$79.95

*continued from page 1*

as we enter the time of a restructured United States Amateur Radio service, we are already 5% behind.

*Thanks to W5YI Report, via Newline, Bill Pasternak WA6ITF, editor.*

## Storms on the Way

Ham radio operators along the eastern seaboard and the Gulf coast may want to get ready to provide a lot of emergency communications for years to come. This, as an analysis of weather patterns over the past century indicate that the increased tropical storm activity over the last five years should continue for the next two decades.

According to top hurricane forecaster William Gray, the next 15 to 20 years could resemble a siege of severe hurricanes that began in the late 1920s and lasted through the 1940s, only worse. Gray says that was a time when relatively high salt content in the Atlantic altered the circulation of ocean currents in a way that pushed up the average water temperature.

But there is a big difference between the 60 or 70 years ago and the year 2000. This is because more people now have chosen to live in harm's way. And Professor Gray cites U.S. census figures that show that the population in the Gulf and Atlantic coast states from Texas to Virginia rose from about 24 million in 1930 to about 64 million in 1990. He also notes that hurricanes draw their strength from warm water, and mixing the two factors leads to the conclusion that upcoming storms are expected to cause damage five to ten times worse than ever before in the Gulf and Atlantic coast states.

And what does this mean for radio amateurs who live in the path of these projected storms? In two words, volunteerism and preparedness.

Hams should think in terms of volunteering their time to their local ARES or some other emergency preparedness group that requires radio communications. And all hams — not just those who live where a hurricane might strike — should learn emergency communications procedures and take part in practice sessions on a regular basis.

Even with modern satellite technology and multiple redundancy in the landline and cellular telephone networks, commercial services are often the first to disappear when Mother Nature's fury strikes. It's then that ham radio operators are called on to fill in until normal communications can be restored.

Gray is a professor of meteorology at Colorado State University in Fort Collins, Colorado, and is widely viewed as the nation's top hurricane forecaster. In 1999, he predicted 14 named storms, nine of which became hurricanes. For 2000, Gray has predicted 11 named storms, including seven hurricanes. He says that three of them will be major severe weather events.

*Thanks to Newline, Bill Pasternak WA6ITF, editor.*

## Next Stop: White House?

The Ashland (NE) Amateur Radio Club, at its March meeting, elected a new president. What makes this a little unusual is the fact that the new club president is only 12 years old! Evan Anderson KC0CWP, a Technician, was elected club president. Evan received a two-thirds majority vote of the 17-member club.

Evan, who was born with spina bifida, received his ticket when he was only 10 years old, and is very active on 6 meters, packet, and ATV, as well as the local repeaters.

He also helps run net control on the Ashland Amateur Radio Club's 2 meter ARES weekly nets, and has run several severe weather nets.

In addition to amateur radio, Evan plays wheelchair basketball with the Nebraska Red Dawgs, who placed second in the nation at the 8th Annual Junior Wheelchair Basketball Tournament in Berkeley, California.

Evan is currently studying for his General ticket, and you should see him on the HF bands shortly. The members of the club elected Evan because of his youth and enthusiasm, and are looking forward to a fun and adventure-filled year.

WC0CWP comes from a ham-filled family. His grandfather is Marvin Anderson KA0EOE; his uncle, Dan Anderson, is KA0EOF; Dan's wife, Cristi, is KB7RAV; and Evan's proud dad is Matthew Anderson KA0BOJ.

*Thanks to Newline, Bill Pasternak WA6ITF, editor.*

## Alzheimer's Radio Care

Radio-locating may soon be a part of treatment to keep tabs on Alzheimer's patients. In Japan, where nearly two million elderly Japanese suffer dementia and "go walkabout," Mitsui & Co. is tracking them by satellite.

The system works a bit like the emergency positioning beacons or EPIRBS used at sea: A small transmitter is worn by the person, or attached to his or her clothing. If they go missing, family or relatives use a portable terminal to request that the transmitter be activated, and a computerized map is displayed showing the position of the missing person.

Anyone with an Alzheimer patient in their family will appreciate this latest use of radio to keep track of their loved one.

*Thanks to Q-News, via Newline, Bill Pasternak WA6ITF, editor.*

## You're Getting Older If You Can Remember ...

- Being sent to the drugstore to test vacuum tubes for the TV or radio.
- When Kool-Aid was the only drink for kids, other than milk and sodas.
- When boys couldn't wear anything but leather shoes to school.
- When it took five minutes for the TV to warm up and the picture to stop rolling.

*Continued on page 61*

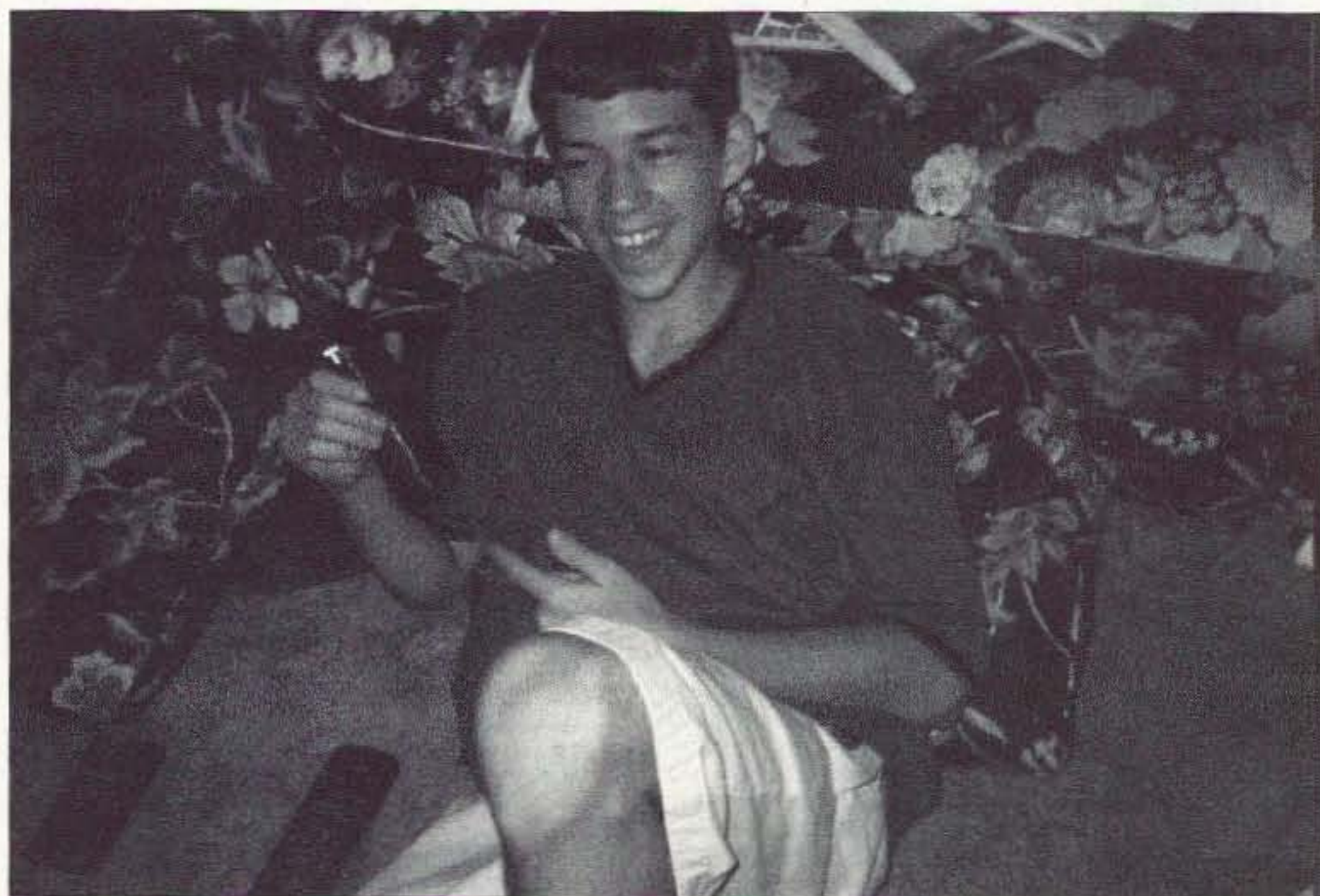

**Barry Hammond KE4PUD**, of Roanoke VA, was first licensed at the age of nine — Tech Plus! When he was 12, he had the pleasure of operating from Australia and New Zealand. Barry enjoys paintball and soccer when he's not on the air with his 220 MHz HT. (Photo by Glenn Hammond, Sr. K4YDG)



# MFJ 1.8-170 MHz SWR Analyzer™

## Reads complex impedance . . . Super easy-to-use

New MFJ-259B reads antenna SWR . . . Complex RF Impedance: Resistance(R) and Reactance(X) or Magnitude(Z) and Phase(degrees) . . . Coax cable loss(dB) . . . Coax cable length and Distance to fault . . . Return Loss . . . Reflection Coefficient . . . Inductance . . . Capacitance . . . Battery Voltage. LCD digital readout . . . covers 1.8-170 MHz . . . built-in frequency counter . . . side-by-side meters . . . Ni-Cad charger circuit . . . battery saver . . . low battery warning . . . smooth reduction drive tuning . . . and much more!

*The world's most popular SWR analyzer just got incredibly better and gives you more value than ever!*

MFJ-259B gives you a complete picture of your antenna's performance. You can read antenna SWR and Complex Impedance from 1.8 to 170 MHz.

You can read Complex Impedance as series resistance and reactance (R+jX) or as magnitude (Z) and phase (degrees).

You can determine velocity factor, coax cable loss in dB, length of coax and distance to a short or open in feet.

You can read SWR, return loss and reflection coefficient at any frequency simultaneously at a single glance.

You can also read inductance in uH and capacitance in pF at RF frequencies.

Large easy-to-read two line LCD screen and side-by-side meters clearly display your information.

It has built-in frequency counter, Ni-Cad charger circuit, battery saver, low battery warning and smooth reduction drive tuning.

Super easy to use! Just set the bandswitch and tune the dial -- just like your transceiver. SWR and Complex Impedance are displayed instantly!

### Here's what you can do

Find your antenna's true resonant frequency. Trim dipoles and verticals.

Adjust your Yagi, quad, loop and other antennas, change antenna spacing and height and watch SWR, resistance and reactance change instantly. You'll know exactly what to do by simply watching the display.

Perfectly tune critical HF mobile antennas in seconds for super DX -- without subjecting your transceiver to high SWR.

Measure your antenna's 2:1 SWR bandwidth on one band, or analyze multiband performance over the entire spectrum 1.8-170 MHz!

Check SWR outside the ham bands without violating FCC rules.

Take the guesswork out of building and adjusting matching networks and baluns.

Accurately measure distance to a short or open in a failed coax. Measure length of a roll of coax, coax loss, velocity factor and impedance.

Measure inductance and capacitance. Troubleshoot and measure resonant frequency and approximate Q of traps, stubs, transmission lines, RF chokes, tuned circuits and baluns.

Adjust your antenna tuner for a perfect 1:1 match without creating QRM.

And this is only the beginning! The

**NEW**



Call your favorite dealer for your best price! MFJ-259B **\$259.95**

MFJ-259B is a complete ham radio test station including -- frequency counter, RF signal generator, SWR Analyzer™, RF Resistance and Reactance Analyzer, Coax Analyzer, Capacitance and Inductance Meter and much more!

### Call or write for Free Manual

MFJ's comprehensive instruction manual is packed with useful applications -- all explained in simple language you can understand.

### Take it anywhere

Fully portable, take it anywhere -- remote sites, up towers, on DX-peditions. It uses 10 AA or Ni-Cad batteries (not included) or 110 VAC with MFJ-1315, \$14.95. Its rugged all metal cabinet is a compact 4x2x6 3/4 inches.

### How good is the MFJ-259B?

MFJ SWR Analyzers™ work so good, many antenna manufacturers use them in their lab and on the production line -- saving thousands of dollars in instrumentation costs! Used worldwide by professionals everywhere.

### More MFJ SWR Analyzers™

MFJ-249B, \$229.95. Like MFJ-259B, but reads SWR, true impedance magnitude and frequency only on LCD. No meters.

MFJ-209, \$139.95. Like MFJ-249B but reads SWR only on meter and has no LCD or frequency counter.

MFJ-219B, \$99.95. UHF SWR Analyzer™ covers 420-450 MHz. Jack for external frequency counter. 7 1/2 x 2 1/2 x 2 1/4 inches. Use two 9 volt batteries or 110 VAC with MFJ-1312B, \$12.95. Free "N" to SO-239 adapter.

### SWR Analyzer Accessories

#### Dip Meter Adapter

MFJ-66, \$19.95. Plug a dip meter coupling coil into your MFJ SWR Analyzer™ and turn it into a sensitive and accurate bandswitched dip meter. Save time and take the guesswork out of winding coils and determining resonant frequency of tuned circuits and Q of coils. Set of two coils cover 1.8-170 MHz depending on your SWR Analyzer™.

#### Genuine MFJ Carrying Case

MFJ-29C, \$24.95. Tote your MFJ-259B anywhere with this genuine MFJ custom carrying case. Has back pocket with security cover for carrying dip coils, adapters and accessories.

Made of special foam-filled fabric, the MFJ-29C cushions blows, deflects scrapes, and protects knobs, meters and displays from harm.

Wear it around your waist, over your shoulder, or clip it onto the tower while you work -- the fully-adjustable webbed-fabric carrying strap has snap hooks on both ends.

Has clear protective window for frequency display and cutouts for knobs and connectors so you can use your MFJ SWR Analyzer™ without taking it out of your case. Look for the MFJ logo for genuine authenticity!

MFJ-99, \$54.85. Accessory Package for MFJ-259B/249B/209. Includes genuine MFJ-29C carrying case, MFJ-66 dip meter adapter, MFJ-1315 110 VAC adapter. **Save \$5!**

#### New! Tunable Measurement Filter™

MFJ-731, \$89.95. Exclusive MFJ tunable RF filter allows accurate SWR and impedance measurements 1.8 to 30 MHz in presence of strong RF fields. Has virtually no effect on measurements. Works with all SWR Analyzers.

### MFJ No Matter What™ warranty

MFJ will repair or replace (at our option) your MFJ SWR Analyzer™ for one full year.

### Free MFJ Catalog

Nearest Dealer . . . 800-647-1800

<http://www.mfjenterprises.com>

• 1 Year No Matter What™ warranty • 30 day money back guarantee (less s/h) on orders from MFJ

**MFJ ENTERPRISES, INC.**  
Box 494, Miss. State, MS 39762  
(601) 323-5869; 8-4:30 CST, Mon.-Fri.  
FAX: (601) 323-6551; Add s/h  
Tech Help: (601) 323-0549

Prices and specifications subject to change. (c) 1998 MFJ Enterprises, Inc.

MFJ-224 **\$159.95** **MFJ 2 Meter FM Signal Analyzer™**  
Measure signal strength over 60 dB range, check and set FM deviation, measure antenna gain, beamwidth, front-to-back ratio, sidelobes, feedline loss in dB. Plot field strength patterns, position antennas, measure preamp gain, detect feedline faults, track down hidden transmitters, tune transmitters and filters. Plug in scope to analyze modulation wave forms, measure audio distortion, noise and instantaneous peak deviation. Covers 143.5 to 148.5 MHz. Headphone jack, battery check function. Uses 9V battery. 4x2 1/2 x 6 3/4 in.

**More hams use MFJ SWR Analyzers™ than any others in the world!**

# LETTERS

## From the Ham Shack

**Gerry KC6YOO.** I have enjoyed your magazine and editorials for many years. In fact, I have bought many of the 73 past issues at hamfests for the construction articles and for your editorials. Many years ago, I was introduced to ham radio by reading your magazine. It seems that ham radio was a well kept secret where I lived at the time (Los Angeles CA). Due to your editorials, I have been introduced to colloidal silver and the work of Dr. Robert Beck. I currently use two of his devices. What I like about your editorials is that you cover ham activities and other things in a wide spectrum — man does not live by radio alone! I wanted to personally thank you for your efforts over the years. I have a question that maybe you can help me with. You write of incentive licensing and the like. I have read many of the editorials and talked to many older hams. I haven't been able to get the full story. Could you tell me where I can get the information either through your articles or other reading material?

*I should keep an index to my editorials. I've written in detail about the Incentive Licensing catastrophe many times, so keep checking back issues. — Wayne.*

**Robert J. Hajek W9QBH, Riverside IL.** I looked at the cover of the March 2000 issue of 73 Magazine with nostalgia as I viewed the collection of microphones. I looked into the first few pages for a description and found that there was a full story on page 29.

As I read through the narrative, it dawned on me that the microphone information provider certainly did 73 Magazine an injustice with misinformation. It was obvious that the degree of familiarity was lacking.

I can excuse the calling the "77D" an RCA 77 microphone. But the other RCA microphone is not a 44BX but an RCA 74B "Junior Velocity" microphone. I did not need the enclosed catalog pages to determine this, as I presently own a 74B that is in better shape than the displayed unit and did in the past own a "44BX."

When I was a kid, I had an audio "broadcast station" to the neighbors. I was aware of the old restricted radiation problems of low power broadcasting, and used the microphones in addition to just being the proud owner. So I well remember using the units without the need for any auxiliary power which raises the question of being described as "condenser" mikes. No "phantom-powered

external preamp" was used, just a matched impedance to an amplifier with sufficient gain. Please note that there is no reference to any supplemental power in any of the specification sheets.

The major benefit of the RCA 77D was its adjustable directional characteristics which allowed a single microphone to fit almost any application.

Sorry to rain on someone's parade, but being the packrat I am, I just happened to have the documentation to back up my "complaint." I depend on 73 Magazine to be more accurate. You wouldn't want me to lose faith in W2NSD, would you?

*Not at all, Bob: I did win my in-house bet that you would spot those things. — Wayne.*

**Steven Myers WB7SON.** You and your editorial column have been a source of much information, as well as inspiration. You are one of the few sources that provide information about a world that is quite different from what we are told on the boobtube and newspapers. Your ideas and information in the areas of health, nutrition, education, business, technology, and more have improved the lives of many people around the world.

**Jack Sauers, Seattle WA.** The Ice Age is "right on schedule," and the quasi-biennial polar oscillation cycle has shifted mostly to the east coast this winter, though last winter we set the new all-world snowfall record at Mt. Baker, going to 102 feet there, with a 15 foot holdover in September and over 25 feet of new snow or more this past fall and winter there in the Northern Cascades. However, we have set new record cold and snowfall records in Georgia and N. Carolina.

Robert Felix has my forecast times for volcanic eruptions, earthquakes, and storms on his Web site with the track record for Year 2000 thus far. That's at [<http://members.aol.com/iceagenow/>], and he included my latest published paper, "Global Cooling Is Underway", from 21st Century Science & Technology, Spring 1999, in the 2nd edition of his book, *Not By Fire, But By Ice*. The Alaska Snow Crab Commission has now postponed the snow crab season from Jan. 15 to April 1, 2000, or later, because of a big buildup of ice in the Bering Sea, and the pack ice around Antarctica has moved out from one mile to 33 miles —

that's 10 feet thick that the icebreakers going into Antarctica have to plow through now.

So far, Professor Bentley, from the Polar Research Institute at the Univ. of Wisconsin, is turning out right as Antarctica is going up at 0.2 meter/year, increasing in mass balance by 200 gigatons/year, lowering sea level by 1–2mm/year. Sea level along the Washington coast relative to the coast line is also falling from tide gauges at 102mm/year, like in Australia. My estimate is that there's a mass balance outflowage of ice in Antarctica with 1000 gigatons/year breaking off in huge masses.

Greenland is not only going up at 0.1 meter/year as Zwally from NASA had published in EOS in 1989, but his work was redone and verified, and a laser study done too, to verify that. You can see more global cooling data in the latest paper, "The Global Warming Folly," that's published in the Winter 1999/2000 issue of 21st Century Science & Technology, by a Polish scientist with 99 references. Do you know what other hardwoods have been dying back in your area like the sugar maples in Vermont, that died from the Quebec ice storm? Are the moose still migrating south?

The U.S. Weather Service now has a new climate model called the Pacific Decadal Oscillation Model, that forecasts colder and wetter times at higher latitudes for the next ten years, and drier conditions at lower latitudes like Texas and Arizona. That's in line with the now declassified USCIA models in their papers published in the book *The Weather Conspiracy, the Coming of the New Ice Age*, Ballantine Books, 1977. They forecast political consequences like the collapse of empires like the Soviet Union, and starvation like in N. Korea. I wrote the CIA to complain to them and also to the Center for Climatic Studies in Madison for the success of their forecasts, and have also notified the U.S. Weather Service of my forecasts.

**Chris Waldrup KD4PBJ.** Well, I tried out HF for the first time! Today I actually talked with three Germans, one Dutch, one Spaniard, one Czech, two Italians, one Colombian, and one ham from Washington state. With my antenna 20 feet above the ground and only 100 watts! I was shaking so much with the first QSO that I had to look up at the top of my notebook to remember my callsign. Ham radio is great! Especially 10 meters right now! 73

## HIGH QUALITY VHF & UHF EXCITER & RECEIVER MODULES

### FM EXCITERS:

Rated for continuous duty, 2W continuous duty output.

**T301 Synthesized VHF Exciter:** for various bands 139-174MHz, 216-226 MHz. Dip switch freq. setting.

- Kit (ham bands only) ...\$109 (TCXO option \$40)
- Wired/tested, incl TCXO...\$189

**T304 Synthesized UHF Exciter:** various bands 400-470 MHz.

- Kit (440-450 ham band only) incl TCXO ...\$149
- Wired/tested...\$189



### CRYSTAL CONTROLLED:

- TA51: for 6M, 2M, 220 MHz ..... kit \$99, w/t \$169
- TA451: for 420-475 MHz. .... kit \$99, w/t \$169
- TA901: for 902-928 MHz, (0.5W out) ..... w/t \$169

### VHF & UHF POWER AMPLIFIERS.

Output levels from 10W to 100W..... Starting at \$99

### FM RECEIVERS:

Very sensitive - 0.2µV.

Superb selectivity, >100 dB down at ±12 kHz, best available anywhere, flutter-proof squelch.

**R301 Synthesized VHF Receiver:** various bands 139-174MHz, 216-226 MHz.

- Kit (ham bands only) ...only \$139 (TCXO option \$40)
- Wired/tested ...\$209 (includes TCXO)

**R304 Synthesized UHF Receiver:** various bands 400-470MHz.

- Kit (440-450 ham band only) incl TCXO ...\$179
- Wired/tested...\$209

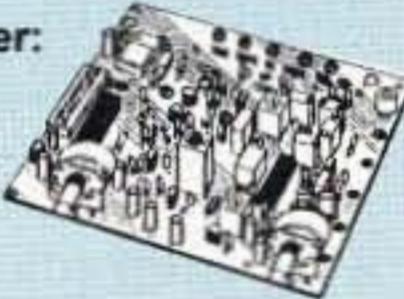

### CRYSTAL CONTROLLED:

- R100 RCVR. For 46-54, 72-76, 140-175, or 216-225 MHz. .... kit \$129, w/t \$189
- R144 RCVR. Like R100, for 2M, with helical resonator in front end..... kit \$159, w/t \$219
- R451 RCVR, for 420-475 MHz. Similar to R100 above. .... kit \$129, w/t \$189
- R901 RCVR, 902-928MHz ..... kit \$159, w/t \$219

## R121 AVIATION RECEIVER

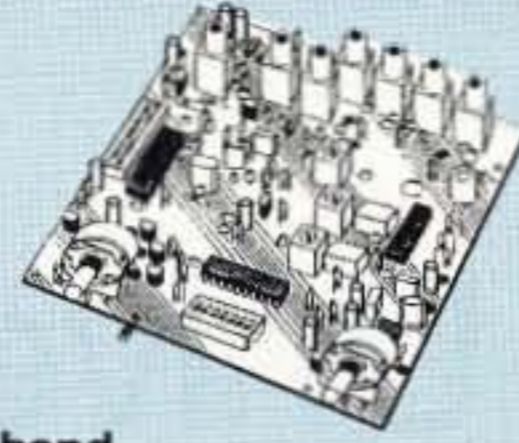

Exciting new AM receiver for the 118-137 MHz aircraft band.

- Ideal for monitoring at small airports.
- Allows pilot control of runway lighting.
- High-quality ELT monitor to detect and locate downed aircraft.
- Dip switch frequency selection.
- Superior sensitivity and selectivity.

R121 Receiver module wired/tested .....\$209  
R121 Receiver in A87 cabinet .....\$299

## LOW NOISE RECEIVER PREAMPS

### LNY-( ) ECONOMY PREAMP ONLY \$29/w&t

- Miniature MOSFET Preamp.
- Low noise figure.
- Available for various bands from 28 to 450 MHz.



### LNP-( ) PRESELECTOR ONLY \$39/w&t

- Eliminate intermod!
- Low noise preamp
- Sharp 3-section filter
- Available for bands from 137 to 170 MHz.

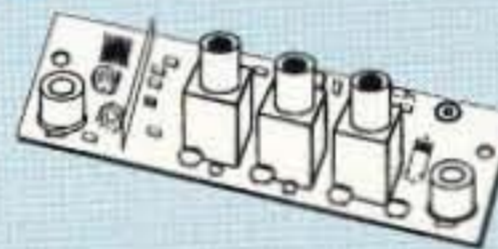

### LNG-( ) GaAs FET PREAMP

STILL ONLY \$59, wired/tested

Available for 28-30, 46-56, 137-152, 152-172, 210-230, 400-470, and 800-960 MHz bands.



## SUBAUDIBLE TONE ENCODER/DECODER



Access all your favorite closed repeaters!

- Encodes all standard CTCSS tones with crystal accuracy and convenient DIP switch selection.
- Decoder can be used to mute receive audio and is optimized for installation in repeaters to provide closed access. High pass filter gets rid of annoying rcvr buzz.
- TD-5 CTCSS Encoder/Decoder Kit .....now only \$39
- TD-5 CTCSS Encoder/Decoder Wired/tested.....\$59

## TRANSMITTING & RECEIVING CONVERTERS

No need to spend thousands on new transceivers for each band!



- Convert vhf and uhf signals to & from 10M.
- Even if you don't have a 10M rig, you can pick up very good used xmtrs & rcvrs for next to nothing.
- Receiving converters (shown above) available for various segments of 6M, 2M, 220, and 432 MHz.
- Rcvg Conv Kits from \$49, wired/tested units only \$99.

- Transmitting converters for 2M, 432 MHz.
- Kits only \$89 vhf or \$99 uhf.
- Power amplifiers up to 50W.



## WEATHER FAX RECEIVER

Join the fun. Get striking images directly from the weather satellites!

A very sensitive wideband fm receiver optimized for NOAA APT & Russian Meteor weather fax on the 137MHz band.

Covers all 5 satellite channels. Scanner circuit & recorder control allow you to automatically capture signals as satellites pass overhead, even while away from home.

See product review with actual satellite pictures in June 1999 QST, along with info on software and antennas.

- R139 Receiver Kit less case .....\$159
- R139 Receiver Kit with case and AC power adapter \$189
- R139 Receiver w/t in case with AC power adapter ...\$239
- Internal PC Demodulator Board & Imaging Software \$289
- Turnstile Antenna .....\$135
- Weather Satellite Handbook .....\$20



## WWV RECEIVER

Get time & frequency checks without buying multiband hf rcvr. Hear solar activity reports affecting radio propagation.

Very sensitive and selective crystal controlled superhet, dedicated to listening to WWV on 10 MHz. Performance rivals the most expensive rcvrs.

- RWWV Rcvr kit, PCB only .....\$59
- RWWV Rcvr kit with cabt, spkr, & 12Vdc adapter .....\$89
- RWWV Rcvr w/t in cabt with spkr & adapter .....\$129



## Get more features for your dollar with our REP-200 REPEATER

A microprocessor-controlled repeater with full autopatch and many versatile dtmf remote control features at less than you might pay for a bare bones repeater or controller alone!

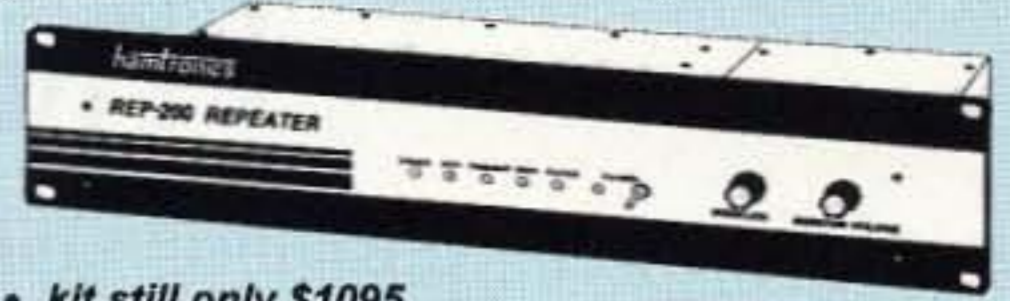

- kit still only \$1095
- factory assembled still only \$1295

50-54, 143-174, 213-233, 420-475 MHz.

FCC type accepted for commercial service in 150 & 450 MHz bands.

Digital Voice Recorder Option. Allows message up to 20 sec. to be remotely recorded off the air. Play back at user request by DTMF command, or as a periodical voice id, or both. Great for making club announcements! .....only \$100

REP-200C Economy Repeater. Real-voice ID, no dtmf or autopatch. .... Kit only \$795, w&t \$1195

REP-200N Repeater. Without controller so you can use your own. .... Kit only \$695, w&t \$995

## You'll KICK Yourself If You Build a Repeater Without Checking Out Our Catalog First!

Hamtronics has the world's most complete line of modules for making repeaters. In addition to exciters, pa's, and receivers, we offer the following controllers.



COR-3. Inexpensive, flexible COR module with timers, courtesy beep, audio mixer. .... only \$49/kit, \$79 w/t

CWID-2. Eprom-controlled ID'er. .... only \$54/kit, \$79 w/t

DVR-1. Record your own voice up to 20 sec. For voice id or playing club announcements. ....\$59/kit, \$99 w/t

COR-4. Complete COR and CWID all on one board. ID in eeprom. Low power CMOS. .... only \$99/kit, \$149 w/t

COR-6. COR with real-voice id. Low power CMOS, non-volatile memory. .... kit only \$99, w/t only \$149

COR-5. µP controller with autopatch, reverse ap, phone remote control, lots of DTMF control functions, all on one board, as used in REP-200 Repeater. ....\$379 w/t

AP-3. Repeater autopatch, reverse autopatch, phone line remote control. Use with TD-2. .... kit \$89

TD-2. Four-digit DTMF decoder/controller. Five latching on-off functions, toll call restrictor. .... kit \$79, w/t \$129

TD-4. DTMF controller as above except one on-off function and no toll call restrictor. .... w/t \$89

## WEATHER ALERT RECEIVER

A sensitive and selective professional grade receiver to monitor critical NOAA weather broadcasts. Good reception even at distances of 70 miles or more with suitable antenna. No comparison with ordinary consumer radios!



Automatic mode provides storm watch, alerting you by unmuting receiver and providing an output to trip remote equipment when an alert tone is broadcast. Crystal controlled for accuracy; all 7 channels (162.40 to 162.55).

Buy just the receiver pcb module in kit form or buy the kit with an attractive metal cabinet, AC power adapter, and built-in speaker. Also available factory wired and tested.

- RWX Rcvr kit, PCB only .....\$79
- RWX Rcvr kit with cabinet, speaker, & AC adapter .....\$99
- RWX Rcvr wired/tested in cabinet with speaker & adapter .....\$139

Buy at low, factory-direct net prices and save! For complete info, call or write for complete catalog. Order by mail, email, or phone (9-12, 1-5 eastern time). Min. \$6 S&H charge for 1" lb. plus add'l weight & insurance. Use Visa, MC, Discover, check, or UPS C.O.D.

See SPECIAL OFFERS and view complete catalog on our web site: [www.hamtronics.com](http://www.hamtronics.com) email: [jv@hamtronics.com](mailto:jv@hamtronics.com)

Our 38<sup>th</sup> Year  
**hamtronics, inc.**  
65-D Moul Rd; Hilton NY 14468-9535  
Phone/fax: 716-392-9430

# The Universal Loop

*A novel, efficient, modularly constructed receiving loop antenna covering from 55 kHz to 40 MHz (or even more).*

*This receiving loop antenna covers a frequency range from 55 kHz–40 MHz (i.e., low LF to low VHF). It uses a range of plug-in loopsticks plus spiral and frame loops. The listening enthusiast will be able to follow the simple instructions to make a system for all-band listening or for just those portions of the spectrum of personal interest. The experimenter will be able to use the base unit as a test-bed for trying out some personal loop designs. Or, maybe, to modify and/or improve some of the ideas presented here. In such cases, much time and effort will be saved in avoiding repetitive constructional work, and trying to locate such components as suitable variable capacitors and other bits and pieces.*

While experimenting with small loop antennas for reception and transmission for many years, I have employed a simple tuning/matching unit for initial loop design work. This test-bed base was built into a well-used plastic box. The

built-in components consisted of tuning capacitors, optional variable coupling capacitors, a coaxial socket, plus a selection of terminals connected to the various components to enable a variety of new loop configurations to be tried over a wide range of frequencies. In many cases, experimental frame loops were “lashed up,” on a simple flimsy lightweight cardboard body. Thus much time and effort was saved, initially, in evaluating a new loop design concept. This established the best dimensions and number of wire turns. When a prototype was eventually made, there was a 95% chance that it would be satisfactory. Again, much time, money and frustration were saved.

with 4mm plug pins. Coupling to the RX input is achieved by variable capacitor C2 (365 pF) connected to the

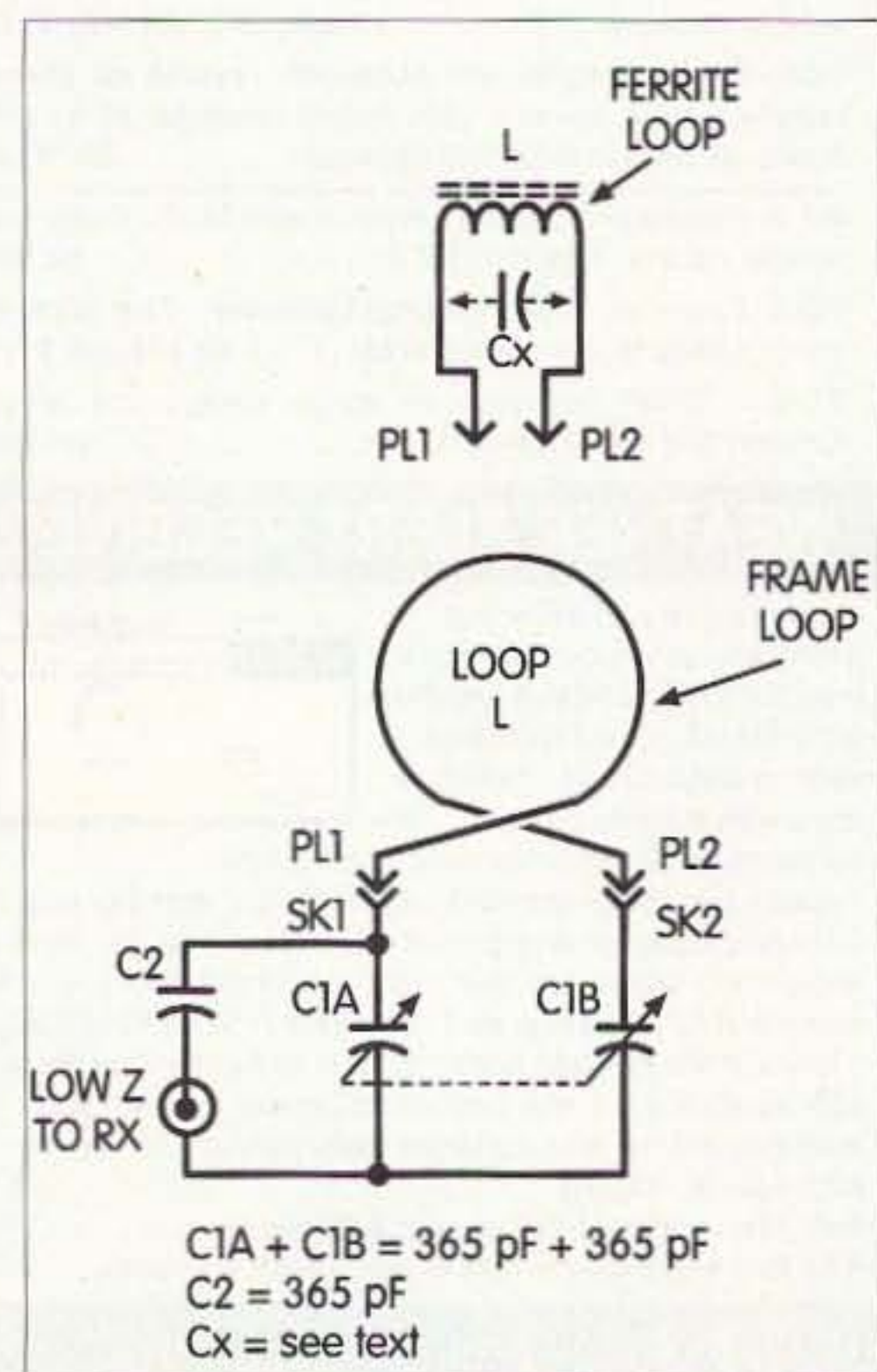

Fig. 1. The versatile schematic of the Universal Loop.

## The Universal Loop

Fig. 1 shows the versatile schematic of the Universal Loop, and Figs. 2(a) and 2(b) the alternative profiles using frame loop configurations and ferrite loops [2(b)].

The schematic consists of a balanced arrangement using a 2 x gang 365 + 365 pF variable capacitor (C1A and C1B), connected to binding post sockets SK1 and SK2. Alternative “plug-in” ferrite and frame loops are fitted

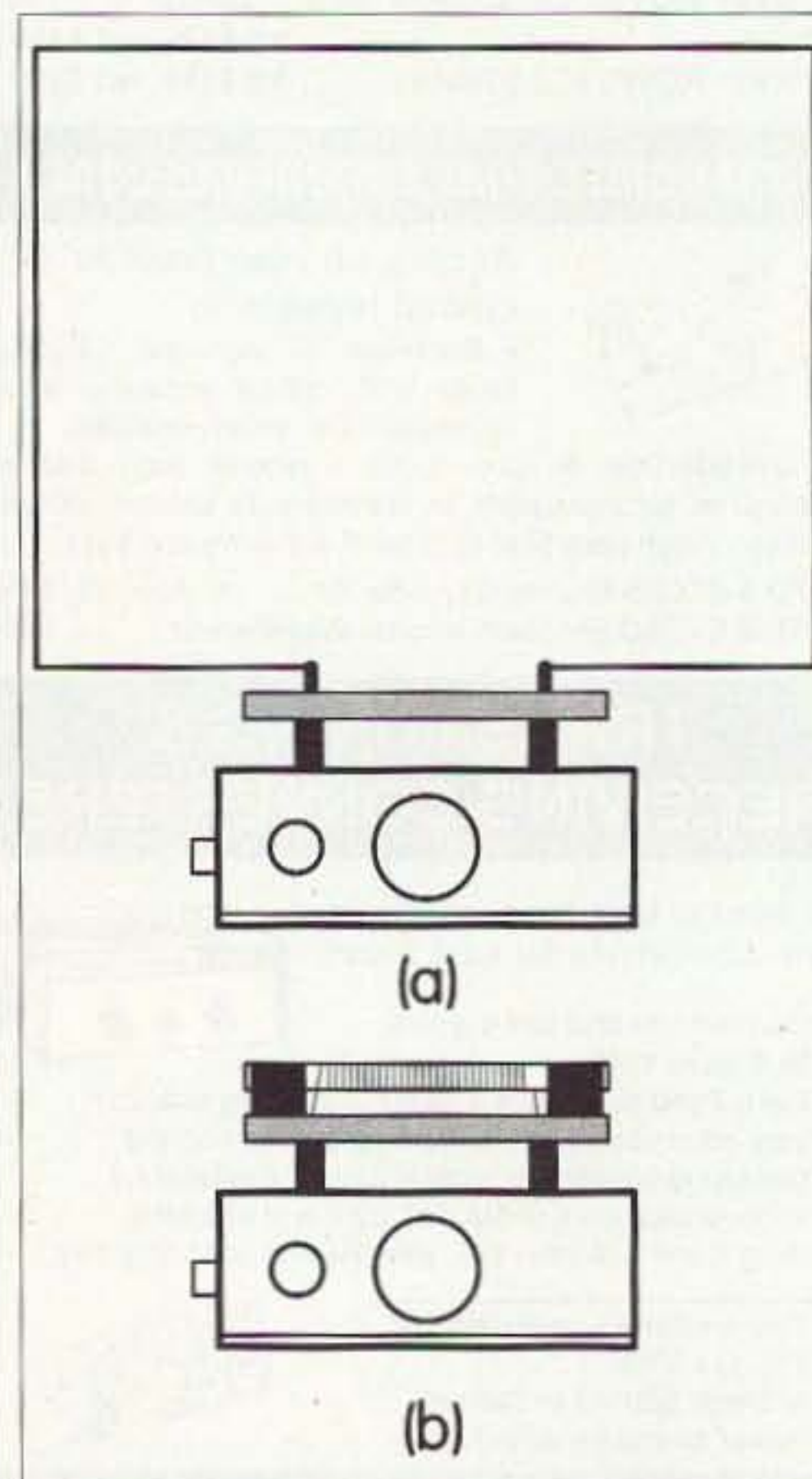

Fig. 2(a) Profile of the frame loop configuration. (b) Profile of the ferrite loop configuration.

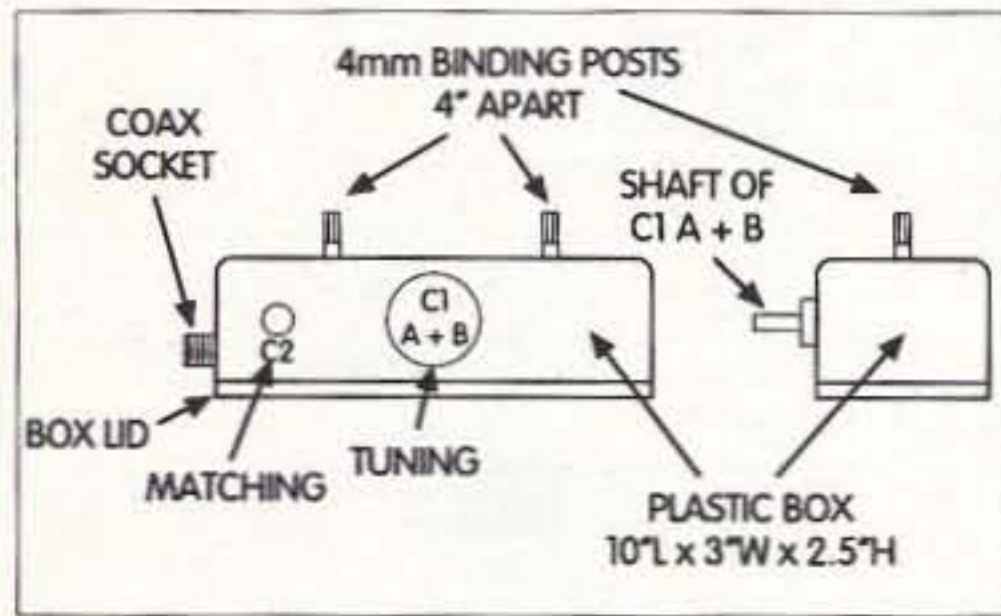

Fig. 3. The tuning/base unit.

coaxial socket. The coaxial feedline can be matched by C2 to 50–80 ohms impedance.

The tuning/base unit (Fig. 3) housing the above is built into a plastic box 10" x 3" x 2-1/2" high. For readiness of availability, at a reasonable cost, a translucent white micro-oven/fridge box is used. However, some dimensional tolerance can be allowed. C1A, C1B, and C2 are mounted on the front as shown in Fig. 3, with the socket at the end. 2 x 4mm binding posts are mounted on the top, as shown, exactly 4" apart. Binding posts are about 1" high, with a 4 mm socket in the end. There is also a side terminal connection. Tandy/Radio Shack nylon binding posts, #274-662, were used on the prototype.

In-box interconnection wiring, to Fig. 1, should be robust and securely soldered, using 18 or 16 gauge tinned copper wire. *Do not rely on mechanical joints.*

Various alternative loop configurations are used (Figs. 6–10), all using a standard plug-in chassis as shown in Fig. 4. The chassis consists of a strip of rigid insulated board (up to 1/8" thick) 8" x 1-1/4" wide (Fig. 4). Two 4

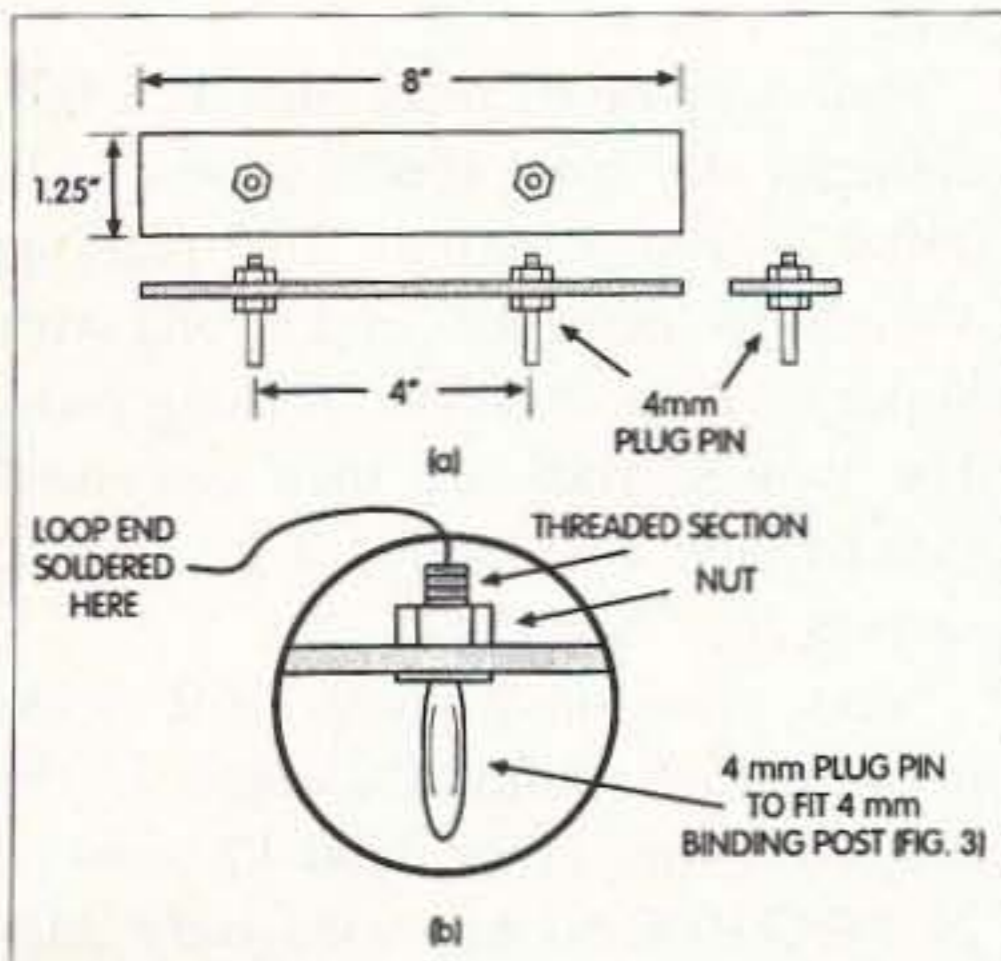

Fig. 4(a) Loop "plug-in" chassis. (b) Plug pin detail.

mm plug pins are mounted as shown, exactly 4" apart, for plugging into the binding posts on the base unit (Fig. 3).

The 4 mm pins are quite standard, with a screw thread on one end to fasten to the chassis board (Fig. 4) with nuts and washers. These pins are available from various suppliers. On the prototype, Maplin type MF72/54403/WB43 pins were used. In the USA, Antiques Electronic Supply was advertising these in their catalog. The various loop configurations (Figs. 6–10) are mounted on these loop "plug-in" chassis.

**Individual "plug-in" loop construction: the MF (MW) loop — 550–2100 kHz (see Fig. 6)**

The starting point is this ferrite loop. I will also describe subsequent loops that just overlap the LF and HF ends of its range.

The unit uses a standard MW bands loopstick 5" long x 0.375" in diameter. This can be salvaged from an old radio, or can be purchased new. In this case, I used my Maplin type LB12N MW/LW ferrite loopstick. This uses a 5" long x 0.375" diameter ferrite rod. The inductance range quoted is 370  $\mu$ H (MW) and 4.1 mH (LW), giving frequency ranges of 550–1550 kHz and 150–280 kHz respectively. The LW coil was removed and kept for the LP loopstick (described later). An alternative MW coil is advertised in the USA by Antique Electronics Supply, under type number P-FRL.

Using the tuning circuit, as shown in Fig. 1, the MW coil will cover from about 550–2100 kHz. The use of a 0.375"-diameter salvaged MW coil of other manufacture may give a slightly different frequency range, but this can be compensated for (see later).

The loopstick is mounted on a loop "plug-in" chassis (Fig. 4). Construction is simple. The two ends of the ferrite rod are secured with plastic "P" clips, and the ends of the winding are soldered to the 4 mm plug pins.

To test this assembly, just plug the completed unit into the binding posts

Continued on page 12

# ALL ELECTRONICS CORPORATION

---

## Laser Level

Use it to match heights in large rooms or across buildings. Locking push button switch prevents unintended actuation. Includes two AAA batteries. **\$16<sup>95</sup> each**  
**CAT # LL-1**

---

## 16 Character X 2 Line LCD with Backlight

Daewoo # 16216L-5-VSO  
 5 x 7 dot format.  
 2.56" x 0.54" viewing area.  
 3.15" x 1.41" module size.  
 LED backlight. Includes hook-up/spec sheet.  
**CAT# LCD-53 \$7<sup>50</sup> each**

---

## 150 Watt Power Supply

Power Switch Corporation  
 # PVI 150-39-PRV  
 Input: 100 – 240 Vac.  
 Outputs:  
 5 Volts @ 8 Amps  
 and 12 Volts @ 8 Amps  
 Maximum output achieved with 20 CFM forced air cooling. New, open-frame switching power supply. 7.13" x 4" x 1.9" high.  
 UL, CSA. **CAT # PS-150 \$8<sup>50</sup> each**

---

## Miniature Illuminated Pushbutton Switch

Mountain Switch (Miyama Electric)  
 # MS-800 / B2SFC. Good-looking miniature D.P.S.T. momentary push-button switch with red lens. Contacts rated 0.1 Amp @ 30 VDC. 0.55" square, matte-black bezel. 0.386" square red lens. Lamp operates on 12 – 28 Volts. Snap-mounts in a 0.5" square cutout. 0.95" behind panel depth. Solder-loop terminals.  
**CAT # PB-100 \$1<sup>75</sup> each**  
**10 for \$16.00**

---

ORDER TOLL FREE  
**1-800-826-5432**  
**SHOP OUR ONLINE STORE**  
[www.allelectronics.com](http://www.allelectronics.com)  
**CHARGE ORDERS to Visa, Mastercard, American Express or Discover**

---

TERMS: NO MINIMUM ORDER. Shipping and handling for the 48 continental U.S.A. \$5.00 per order. All others including AK, HI, PR or Canada must pay full shipping. All orders delivered in CALIFORNIA must include local state sales tax. Quantities Limited. NO COD. Prices subject to change without notice.

CALL, WRITE FAX or E-MAIL for our **FREE** **96 Page CATALOG** Outside the U.S.A. send \$3.00 postage.

MAIL ORDERS TO:  
**ALL ELECTRONICS CORPORATION**  
 P.O. Box 567  
 Van Nuys, CA 91408  
**FAX (818)781-2653**  
**e-mail allcorp@allcorp.com**

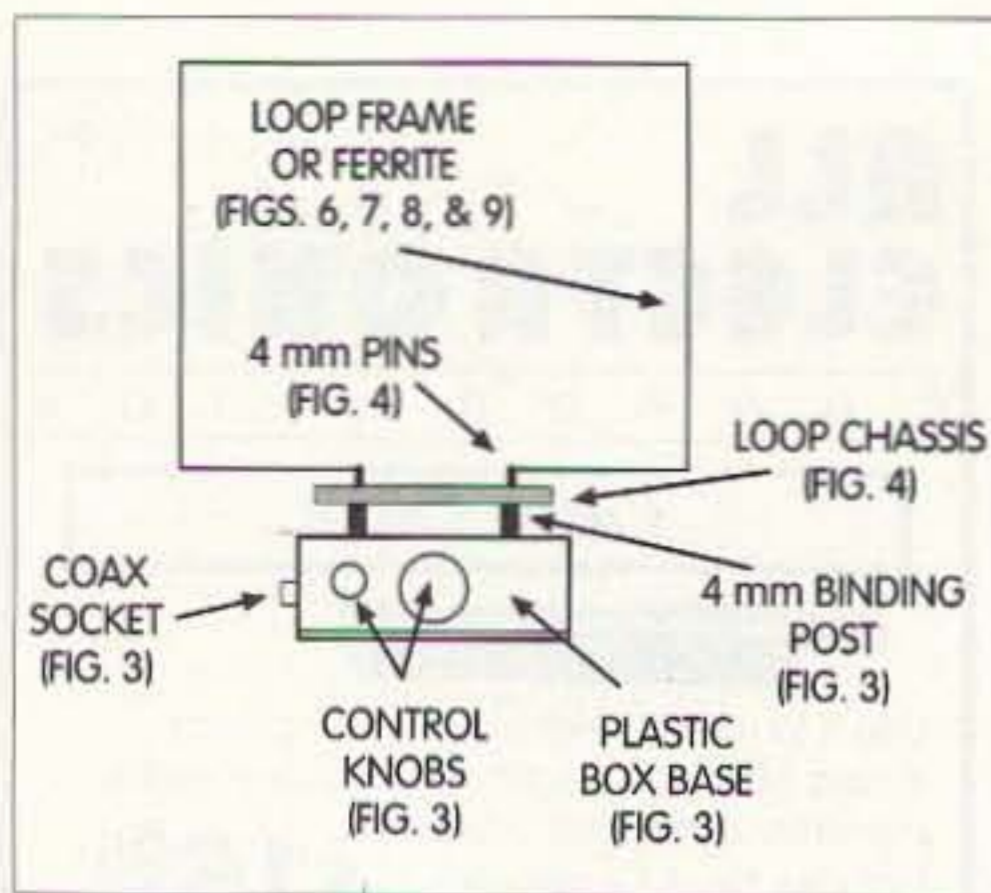

Fig. 5. General layout.

## The Universal Loop continued from page 11

on the base unit [Fig. 2(b)]. Connect the unit to a suitable RX with a short length of coaxial feedline.

Set C2 to about 20% meshed. Select an MW BC station on the RX, and rotate

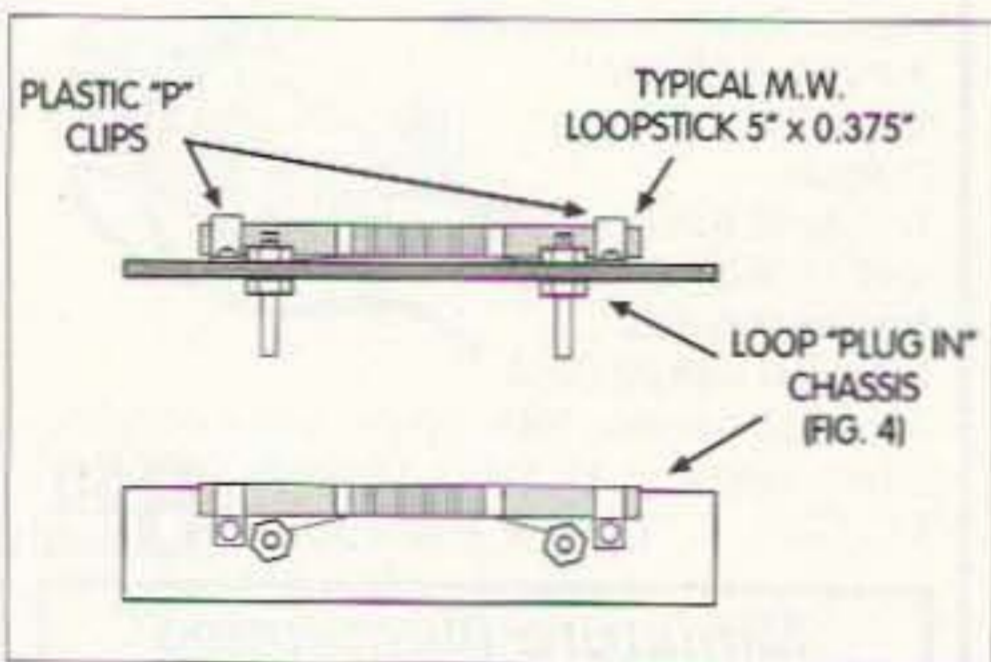

Fig. 6. MF (MW) loop — 550–2100 kHz.

C1A/C1B to resonance, which is indicated by a dramatic increase in signal strength. Gradually adjust coupling capacitor C2 for a gradual increase in signal strength, to a maximum peak, which indicates the required narrowest bandwidth. If the coupling is increased

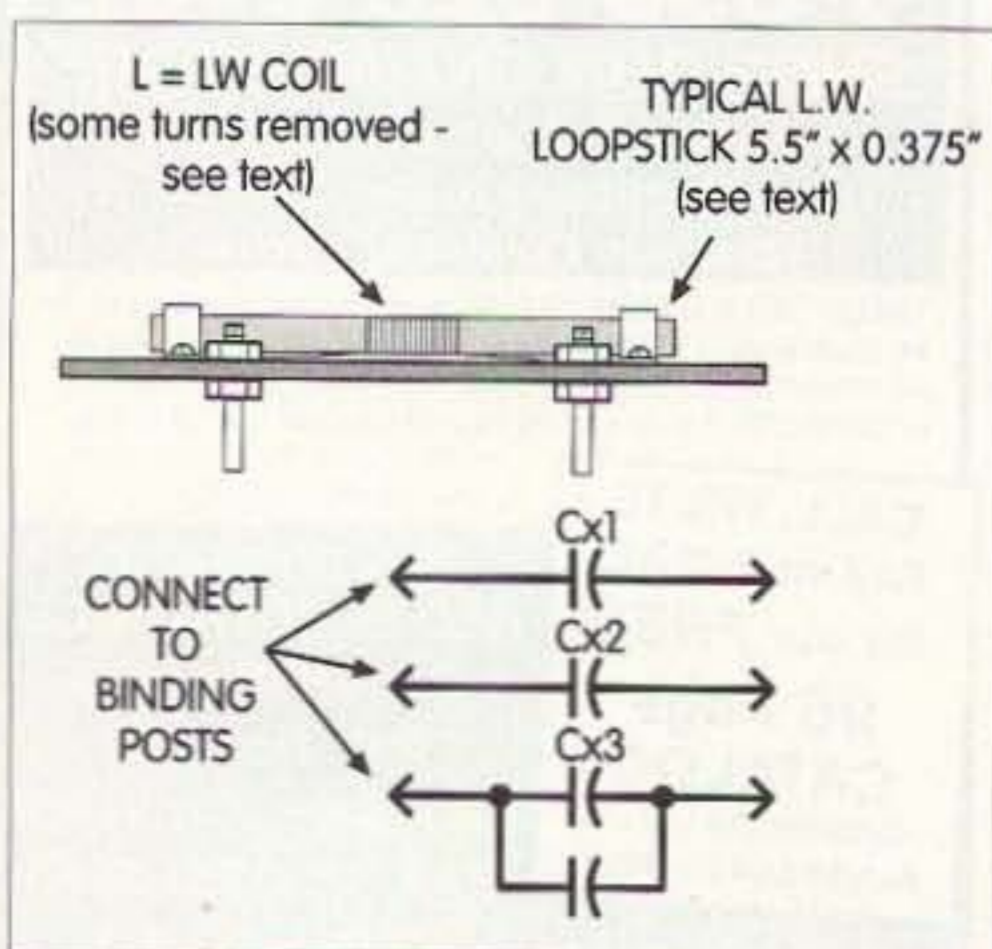

Fig. 7. LF loop — 55 kHz–550 kHz.

further, there will be a fall in signal strength and an increase in bandwidth. The operating point is at the peak signal. C1A/C1B may need a minor readjustment. The directivity range of this ferrite loop can be checked by rotating the loop.

NOTE: This testing/tuning procedure is used on all subsequent loops described.

## The LF (long wave) loop — 150–550 kHz (see Fig. 7)

The construction of this unit is nearly identical to that of the MW loop just described.

A salvaged 0.375" diameter ferrite rod (with LW coil) can be used. However, the LW coil previously removed from the Maplin type LB12N MW/LW ferrite loopstick was slipped onto an 8" long x 0.375"-diameter ferrite rod. An Amidon #61 material rod would be ideal.

This coil assembly was fastened to a loop "plug-in" chassis (Fig. 4) with PVC "P" clips.

This unit was tested using the previously described method. The frequency range was found to be 135–425 kHz. To raise the HF end of the frequency range to overlap the LF end of the MW coil, some wire turns were gradually removed (step-by-step) until the HF end of the LW loop coil reached 550 kHz.

The assembly was now tested against a receiver, as previously described, and the revised range became 150 kHz–550 kHz.

## 55 kHz–170 kHz (see Fig. 7)

The above LW (LF) loopstick is used as the basis of an extended LF range by hooking a selection of capacitors across the coil. These silver mica or ceramic capacitors are each secured to a small strip of insulated card or board, with a wire soldered at either end. These wires are fixed across the coil by connecting to the screw terminal part of the binding posts.

Capacitor attachments are required as follows: 110 kHz to 170 kHz, use a 130 pF capacitor. 85 to 110 kHz, use a

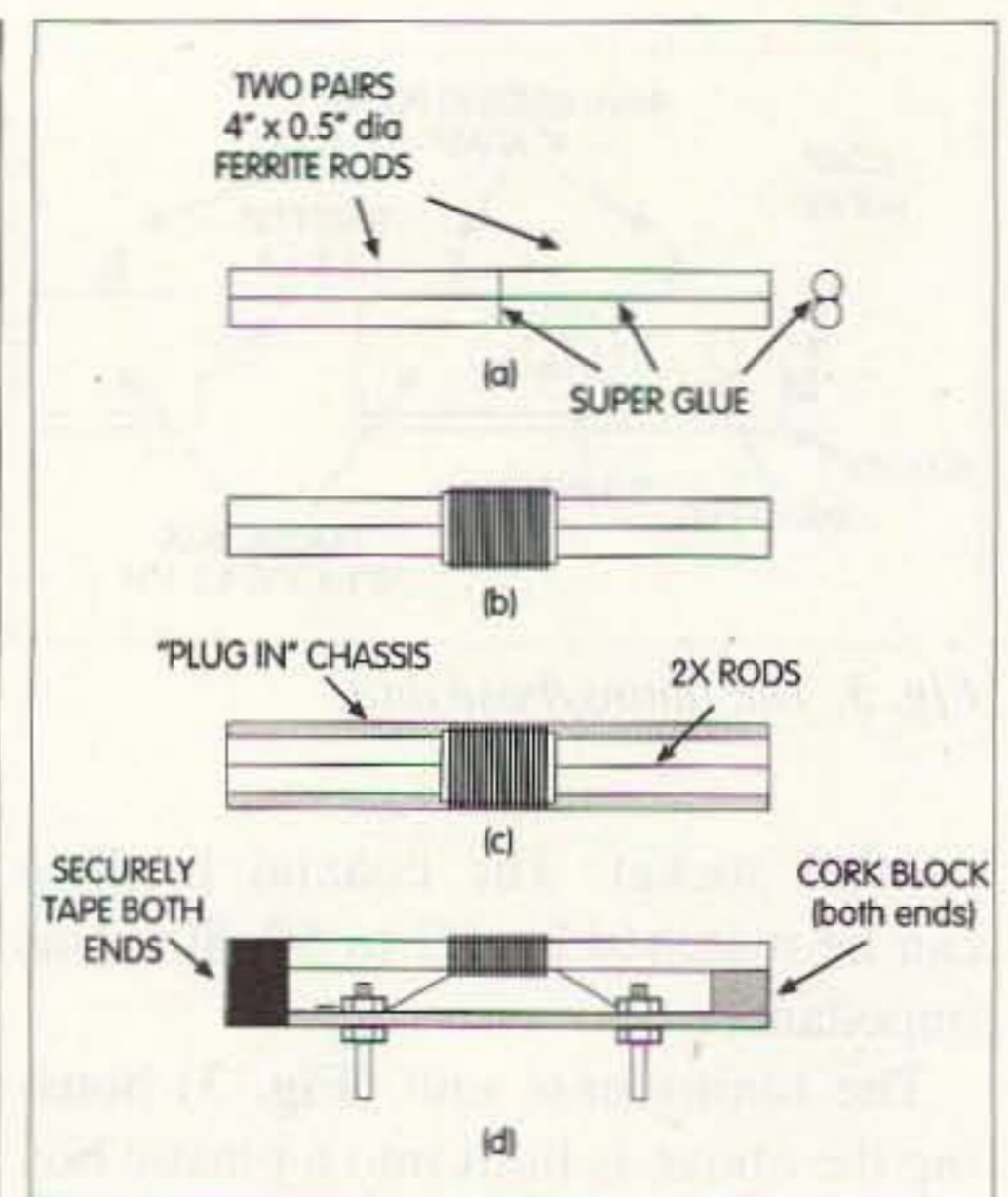

Fig. 8. The 1750–7700 kHz loop.

- (a) Ferrite assembly.
- (b) Winding assembly.
- (c) Final assembly, top view.
- (d) Final assembly, side view.

350 pF. 55 to 68 kHz, use a 1000 pF and 150 pF in parallel.

It follows that an even lower frequency can be obtained by using an even larger capacitor. Adjustment to the specified capacitor values will adjust the individual ranges to an enthusiast's needs.

## The 1750–7700 kHz loop (Fig. 8)

This loop coil covers the next frequency segment up from the MW/MF loop previously described. It uses a ferrite rod core, but in this case a substantially larger core is used to increase the loop sensitivity. This large core is composed of 2" x 8" long 1/2"-diameter Amidon 61 rods, giving a core cross-section of approximately 1" x 1/2".

Four Amidon 61 rods, each 4" x 1/2" diameter are used (code number 61-050-400 from Amidon). Two pairs of 4" rods are cemented end to end with Super Glue to form two 8"-long rods. The two 8" rods are then cemented side-by-side to produce a 1" x 1/2" section core. See Fig. 8.

Next, wind on 2 layers of 2"-wide masking tape around the center of the rod. Over this, close wind 17 turns of 24 AWG PVC hookup wire (o/d = 2.05 mm). Leave 3" tails on the winding ends.

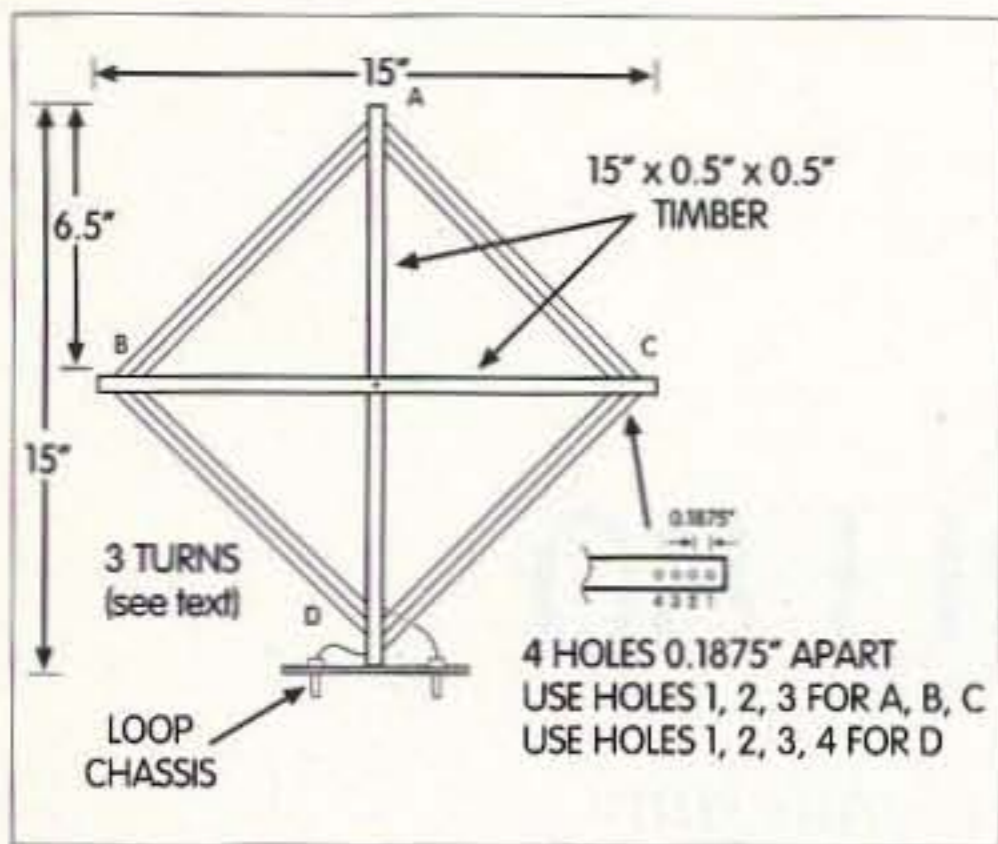

Fig. 9. The 4.300–14.500 MHz loop.

The above coil assembly is mounted on yet another loop plug-in chassis (Fig. 4) as shown in Fig. 8. The rod/coil assembly is uplifted from the loop chassis using cork blocks cut from wine bottle corks. Then securely tape into position as shown. The 3" tails of the winding are cut back, then securely soldered to the ends of the 4 mm plug pins.

Testing and tuning procedures are as previously described for the MW/MF loop, and should give excellent results from approximately 1750–7700 kHz.

#### The 4.300 MHz–14.500 MHz loop (Fig. 9)

Here a simple timber-framed spiral loop is used. A spiral winding is used, as it will give better nulling than a box-style loop.

A simple frame is made from two 15" x 1/2" x 1/2" lengths of hardwood timber. It is formed into a simple cross, as shown. It should be securely glued and bolted at the center of the cross.

Holes are drilled in from the tips of the crosspieces, as shown. The cross is then securely mounted to yet another standard loop plug-in chassis (Fig. 4). Use small nylon angle brackets.

Three full turns of PVC hookup wire are wound through the predrilled holes, as shown, with the ends soldered to the 4mm plug-pin ends.

Testing and tuning procedures are as previously described, and should give a frequency range of approximately 4.300 MHz–14.500 MHz, thus overlapping the previously described loop.

#### The HF to lower VHF Loop — 11.000 MHz–40 MHz (Fig. 10)

This is the simplest loop to construct. All that is needed are four lengths of brass tubing, each 12" long x 1/8" outside diameter, plus one 12" length of brass rod with an o/d such that it will just slip into the tubing. Also required is yet another standard loop plug-in chassis (Fig. 4). The brass tubing and rod were found in a store specializing in scale-model-making materials.

Assemble the brass tubing into a square loop as shown in Fig. 10. Fix

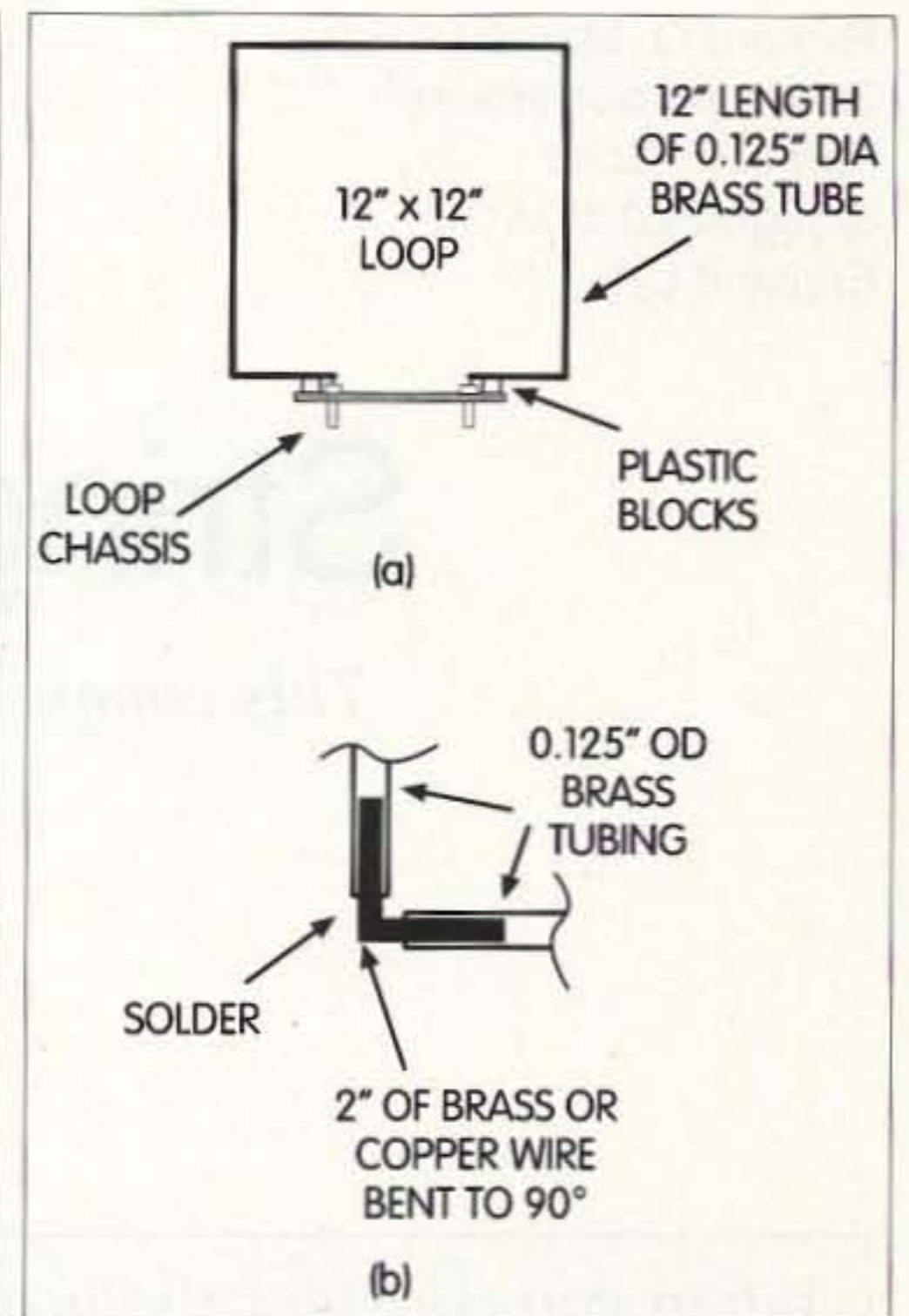

Fig. 10. The HF to lower VHF loop (11–40 MHz).

the four sides together at 90 degrees by cutting 2" lengths of the brass rod and bending them accurately to 90 degrees. After thoroughly cleaning the end, insert the resulting angles into the tube ends and securely and rigidly solder into a square. See (b) in Fig. 10.

Next, cut out a section of the bottom of the loop so that the ends lie on top of

Continued on page 57

**YAESU**  
Performance without compromise.™

YOUR FULL LINE DEALER  
FOR  
ALINCO AND YAESU

**ALINCO**  
AMATEUR RADIO'S VALUE LEADER™

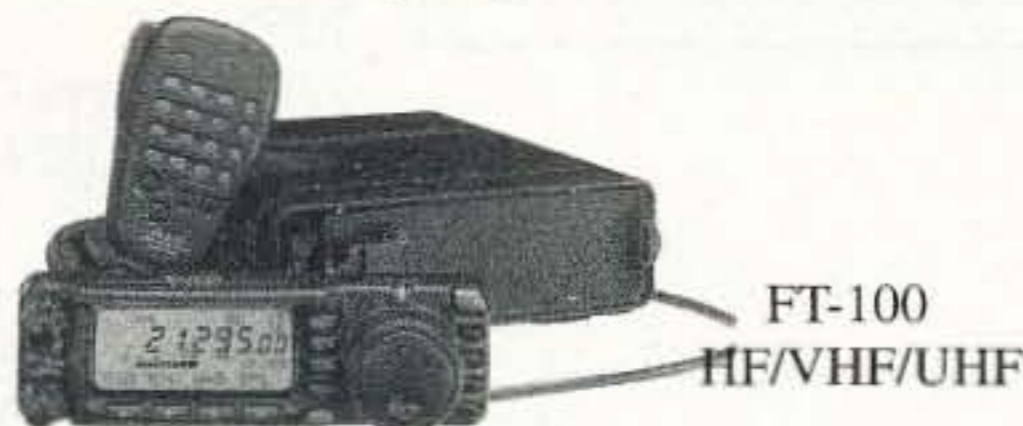

FT-100  
HF/VHF/UHF



DX-70TH  
\$749.00  
HF and 6 Meters

Call for pricing

## EAST COAST Amateur Radio Inc.

314 Schenck St., North Tonawanda, NY 14120  
TEL: (716) 695-3929 • Orders: (800) 995-1787  
See us on the Web! <http://www.eastcoastradio.com>  
Open Mon. - Fri. 12-8 EST • MasterCard/Visa/Discover  
Prices subject to change without notice



DM-330MV  
\$169.00  
NEW Switching  
Power Supply



VX-5R  
Tri-Band Handheld

# String Up the GPU 80

*This compact antenna could be part of your clandestinity.*

When you consider the installation of a new transmitting antenna, usually you first try to answer a few simple questions. From these answers hopefully you can come up with some desired specs, and, as a result, it then can be relatively simple to decide which antenna to D.I.Y.-construct or purchase commercially.

This formula was applied to the GPU 80 antenna. The answers showed that considerable ingenuity would be needed and several conventional textbook rules would need to be broken — or at least severely bent! GPU is an acronym for “General Purpose Utility.”

## Questions

1. Why is the antenna needed?
2. Frequency or frequencies of operation?

3. Location or locations?
4. Space(s) available?
5. Obvious physical installation problems?
6. Earthing/grounding available?

## Antenna specifications

The antenna might, during its lifetime, be required for outdoor, indoor, portable, vacation, or hidden use, on the 80 meter band; hopefully, it would also be usable on 40 and 20 meters.

The antenna must not exceed 6 feet

long when broken down for transit or storage. It must be possible to erect it horizontally, vertically, sloping, or just hanging down. It must be capable of being hidden from view in “antenna-hostile” areas. It must be possible to erect it or take it down in a few minutes. Compatibility with good, not-so-good, and indifferent grounding must be accommodated.

Simple, rapid loading and QSYing

*Continued on page 16*

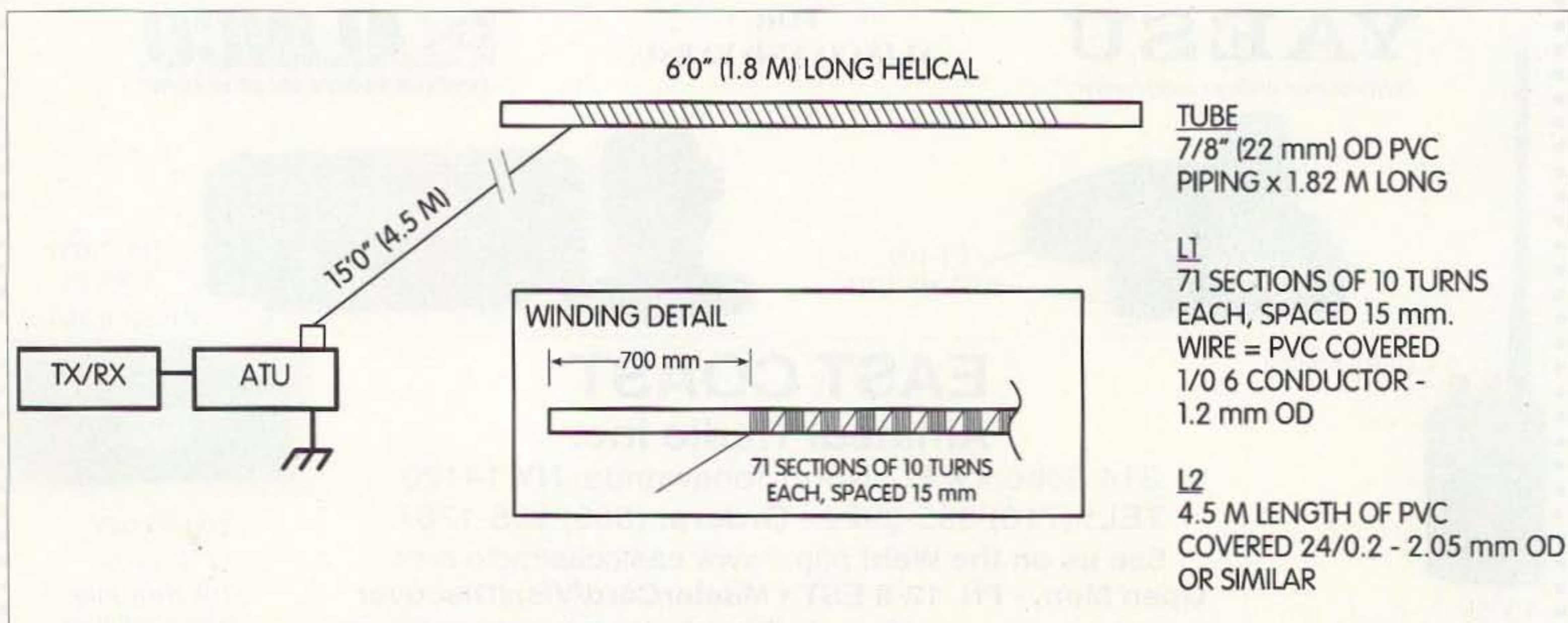

Fig. 1. Schematic of antenna.



# MFJ Contest Voice Keyer

*Brand New design . . . Microprocessor controlled*

*Transformer-coupled -- No RFI, hum or feedback . . . 75 seconds total, 5-messages . . . Can be computer-controlled by CT, NA, etc . . . Records received audio . . .*

Let this new microprocessor controlled MFJ Contest Voice Keyer™ call CQ, send your call and do contest exchanges for you in your own voice!

Store frequently used phrases like "CQ Contest this is AA5MT", "You're 59" . . . "Qth is Mississippi" and more! Contest by pressing a few buttons and save your voice.

You can record and play back five natural sounding messages in a total of 75 seconds. EEPROM technology keeps messages stored for up to 100 years -- no battery backup needed.

Repeat messages continuously and vary the repeat delay from 3 to 500 seconds. Makes calling CQ so easy and it's also a great voice beacon.

A receive audio jack lets you record and play back off-the-air signals -- great help if you didn't get it right the first time! No more "Please repeat".

A playing message can be halted by pressing the Stop Button, your PTT mic button or by your



VOX PTT line. A closure to ground via remote control or computer can also halt messages.

Has jack for remote or computer control (using CT, NA or other program and its interface). Lets you select, play and cancel messages.

The MFJ-434 is transparent to your microphone -- your mic's audio characteristics do not change when your MFJ-434 is installed. Dual

controls make it easy to tailor audio level to match your voice.

All audio lines are RF filtered to eliminate RFI, audio feedback and distortion. An audio isolation transformer totally eliminates hum and distortion caused by ground loops.

It's easy to use -- just plug in your 8 pin microphone cable and plug the MFJ-434 shielded cable into your transceiver's mic connector. Internal jumpers let you customize it to Kenwood, Icom, Yaesu, Alinco or Radio Shack rigs. Use your station or built-in microphone for recording.

Built-in speaker-amplifier lets you monitor stored messages. 3.5 mm speaker/headphone jack. SMT technology. Use 9 Volt battery, 9-15 VDC or 110 VAC with optional MFJ-1312B, \$14.95. 6 1/2"Wx2 1/2"Hx6 1/2"D inches.

MFJ-73, \$29.95. Remote Control Head with cable for MFJ-434.

MFJ-434  
**\$179<sup>95</sup>**  
plus s&h

## MFJ Professional grade Boom Mic Headphones

*For marathon contesting, DXing, traffic nets, ragchewing . . . These lightweight, fully padded Boom Mic Headphones make operating superbly comfortable! Flexible gooseneck microphone boom and speech frequency tailored microphone cuts through noise and QRM!*

This professional grade MFJ Boom-Mic Headphones set is designed for contesting, DXing and traffic nets. Features total comfort design with leatherette padding for operating long hours.

Superb 3/4 inch thick padding on each ear and headband lets you wear your headset all day long! So super lightweight, you won't even know they're there! Headband adjusts for a perfect fit to keep out external noise.

The headphones' frequency response is enhanced for communications to bring out speech fidelity that you never knew existed. Signals never sounded so crystal clear.

The flexible microphone boom lets you position the mic comfortably at an optimum distance to minimize silibant sounds.

MFJ's frequency tailored microphone element lets you bust through noise and QRM!



**NEW!**

Total  
Comfort!

MFJ-396  
**\$79<sup>95</sup>**  
plus \$6 s&h

Extra-long 9 2/3 feet of cable lets you move about your ham shack!

Has standard 1/4 inch jack for headphones and 3.5 mm jack for microphone. Build your own adaptor or use MFJ's pre-wired adaptors to match your transceiver. Order MFJ-5396 Y/K/I (YAESU, KENWOOD, ICOM respectively). \$15.95 each.

Even casual operators will appreciate the advantages of MFJ's superbly crafted Boom-Mic headphones for hands-free operating at an incredibly low price.

MFJ-392, \$19.95. Communication Headphones only. Great for ham radio, shortwave listening -- all modes, SSB/FM/AM/ Data/CW.

Each phone has individual volume and speech enhancement control. Superb leatherette padding.

Both MFJ-392 and MFJ-396 have MFJ No Matter What™ one year limited warranty.

### MFJ Communications Speaker

SSB, FM, AM, and CW never sounded so crystal clear! Plug in this MFJ-281 ClearTone™ speaker and bring out communication speech fidelity that you never knew existed.

Restores the smooth sinewave sound that CW naturally generates and makes copying easier. It was carefully designed to improve intelligibility of speech in the frequency range of 600 to 4000 Hz while reducing undesirable noise, static and hum. A top grade 3" Mylar cone speaker is mounted in a well designed baffle. Its fine mesh metal grille allows sound to radiate without muffling. 8 Watts, 8 Ohms. Six foot cord. 3.5 mm mono plug. 3 3/4"x3x2 1/4" inches.



MFJ-281  
**\$12<sup>95</sup>**  
Ship Code A

### MFJ 12/24 Hour DXers Watch



MFJ-181  
**\$39<sup>95</sup>**  
plus \$6 s&h

This MFJ DXers Watch lets you quickly check 12 hour local time and 24 hour time in time zones around the world. By noting day and night areas around its rotatable bezel, you can estimate which bands are open each hour to different parts of the world. You can even estimate best times of gray line propagation. It features a highly accurate Japanese quartz movement. Turn out the lights . . . NiteGlo™ hour, minute and second hands show up in the dark! Has date display. Well-known world cities encircle it's attractive world map face to indicate time zones. A durable stainless steel band adjusts to fit. Attractive giftbox has felt padding. A great gift!!!

### MFJ 12/24 Hour LCD Clock



MFJ-108B  
**\$19<sup>95</sup>**  
plus \$6 s&h

Dual Clock with separate 24 hour UTC and 12 hour local time displays. Large 5/8 inch LCD numerals, heavy brushed aluminum frame, sloped face, battery included. Synchronizable to WWV. 4 1/2"x1x2 in.

**Free MFJ Catalog**  
and Nearest Dealer . . . 800-647-1800

<http://www.mfjenterprises.com>

• 1 Year No Matter What™ warranty • 30 day money back guarantee (less s/h) on orders direct from MFJ

**MFJ** MFJ ENTERPRISES, INC.  
Box 494, Miss. State, MS 39762  
(662) 323-5869; 8-4:30 CST, Mon.-Fri.  
FAX: (662) 323-6551; Add s/h  
Tech Help: (662) 323-0549

Prices and specifications subject to change. (c) 2000 MFJ Enterprises, Inc.

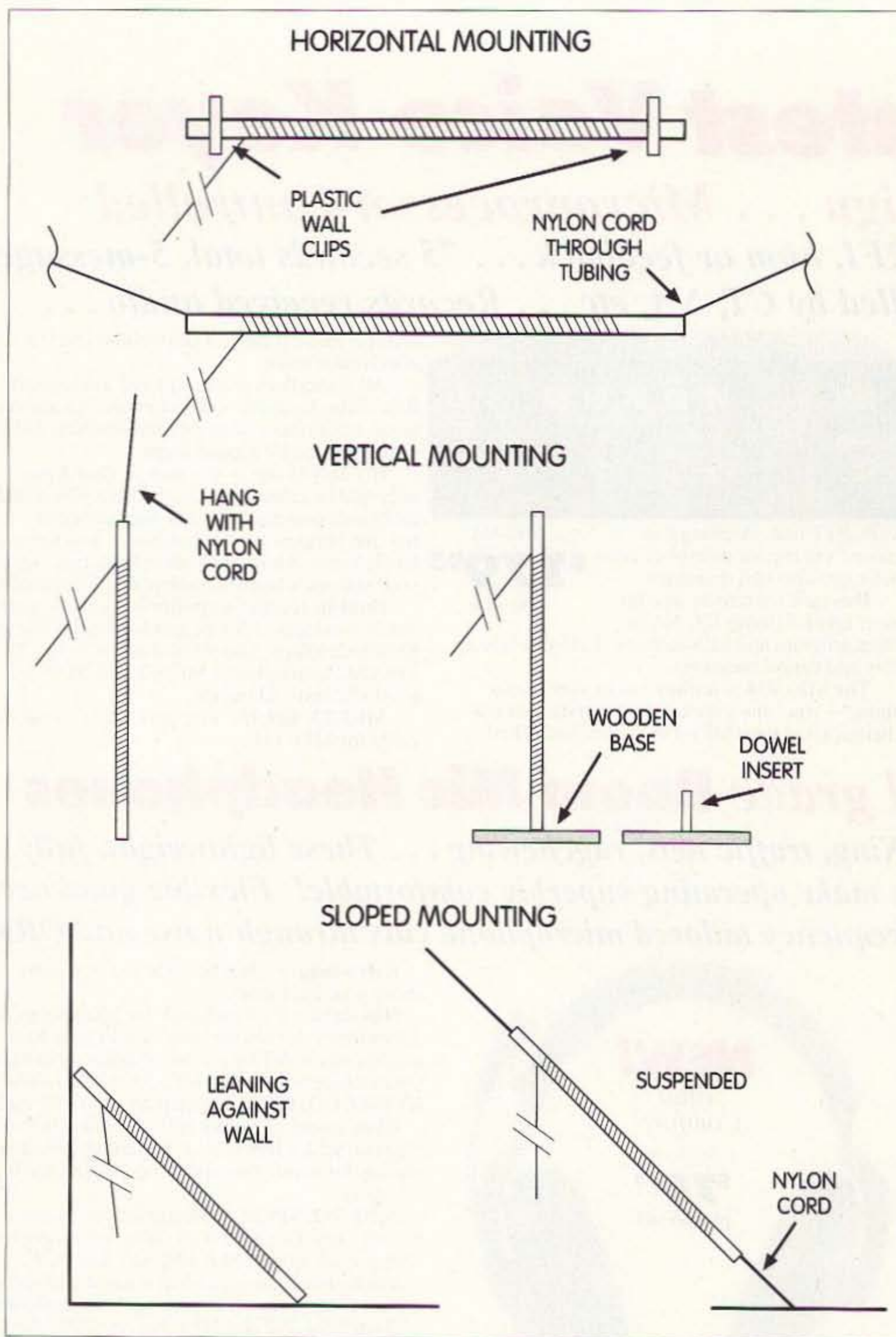

Fig. 2. Various mounting ideas.

## String Up the GPU 80

continued from page 14

with a low SWR is a "must." This is definitely not a textbook antenna!

On the assumption that a 6-foot end-fed helical antenna was the only probability, it was necessary to assess the best possible feeder length. The feeder would be part of the radiating antenna. The antenna would thus consist of the helical and the feedline (see Fig. 1).

In order to arrive at the most convenient length for the feedline, I taped a length of cord to the end of a 6-foot

length of wood dowel. This space model represented the final GPU 80.

I tried the 6-foot dowel in every conceivable position, both indoors and outdoors, as shown in Fig. 2. I determined that a 15-foot feedline would be the most convenient. Thus the antenna would be tailor-made to fit my circumstances.

### Electrical design

A 0.25λ antenna was the first that I considered, but it has an impedance of 35 ohms or less (though often er-

roneously fed with 50-ohm coaxial feed-line). 0.28λ gives a 50 ohm terminal impedance (with reactance present), but a perfect ground, or ground plane, is necessary. Increase the length to 0.375λ and 70 ohms impedance is reached, with considerable reactance, which can be tuned out. Certainly the ground need not be quite so perfect as for 0.28λ.

Bearing in mind that the antenna might be mounted vertically, horizontally, or sloping, with a variety of grounds, I knew there would be changes in both electrical length and impedance at a given frequency. I decided to raise the impedance to just over 100 ohms when the antenna was mounted vertically, horizontally, or sloping. My assumption was that the impedance and electrical length would change depending on how and where the antenna was positioned, and on available grounding. I finally decided on a simple LC ATU to match the antenna impedance and frequency to the 50 ohms impedance TX [see Fig. 3(a)].

Using this technique, I was able to get excellent loading/radiation with low SWR, irrespective of a variety of antenna positions, orientations, and ground facilities (see Fig. 2).

### Construction

The helical antenna L1 is wound on a 6-foot length of 7/8" outside diameter UPVC piping, obtained from a D.I.Y. store. The amount of wire used for this helical, plus the 15 feet of feedline, was first calculated for 3,500 kHz. (NOTE: A good rule of thumb method for calculating the turns/wire length required for a helical antenna is to remember that about twice as much wire is needed as on a straight wire antenna.) It is then usual to gradually prune the antenna to the exact frequency required. As a somewhat unknown territory was being entered, an extra 5% was added as a precaution.

After tuning and loading tests to L1 (Fig. 1), the end results consisted of 71 sections, each consisting of 10 turns of wire spaced 15 mm apart. These windings start at 700 mm from one end of the tubing (see Fig. 1, winding detail). The wire used is PVC-covered 1/0.6 mm conductor, with an o/d of 1.2 mm. This wire specification is mandatory.

A more robust wire was used for feedline L2, as this would be subjected to considerable stress and strain during relocations. The feedline wire was 15 feet of PVC 24/0.2 core, with an o/d of 2.05 mm. Any similar robust wire would suffice.

### Initial pruning, adjustment, and testing

The L1 helical component was erected horizontally, suspended with a nylon cord lengthwise through the tube's center (see Fig. 2). An existing LC ATU was used [Fig. 3(a)]. A field strength meter was placed nearby to check for signal radiation. A small signal was fed into the antenna at 3,500 kHz, and the helical was then cut back turn by turn until resonance was reached. The antenna was then erected vertically, which effectively shortened the antenna from an electrical point of view. This horizontal/vertical exercise was repeated, and a few further turns removed, until the LC ATU would resonate the antenna through the whole 80 meter band, whether the antenna was horizontal, vertical, or sloping. At the same time a variety of grounds were tried, even including a large metal frame window with the antenna hanging out of the window.

The above "cut and try" exercise was somewhat lengthy and tedious. It is probably not always realized that many long established antenna designs now in textbooks were finalized by somewhat similar methods — e.g., the W3EDP.

The end result was the 71 segments (of 10 turns each) wound helically, plus the feedline of 15 feet.

### "On-air" testing

During the above activities, it had been established that the lowest SWR occurred when maximum signal radiation was measured on the field strength meter. This meant that, in practice, the antenna could be tuned up on the radiated signal by variable capacitor C, and taps on L, on the LC ATU [Fig. 3(a)]. SWRs of near 1:1 were achieved when a reasonably good ground was used; they were about 2:1 when a wire fence was used for a ground.

Conveniently, on several days each week, a regular 80m CW contact is made with a friend in Germany, around 350–400 miles. This is usually around 0500 local time, with a frequency of 3,577 kHz  $\pm$  QRM.

The helical was first erected across a room (suspended with nylon cord). The ground was a nearby water pipe. Using about 10 watts, the TX was loaded with the LC ATU for maximum field strength meter reading. No difficulty was experienced, and a good contact was established with the German friend. The following morning, the exercise was repeated with the helical mounted vertically, on the following day with the helical leaning against the wall (away from any house wiring). In all cases, the results I obtained were satisfactory. On the following three days, the exercise was repeated with the antenna outdoors. The results were satisfactory.

An existing "T" section commercial ATU was substituted for the LC unit. The results were similar, though it took far longer to set things up and QSY.

Many readers will have a suitable 80m band LC ATU. If not, you can build one of the simple designs that appear in the various antenna textbooks and magazines.

### Ground connections

The antenna can be erected indoors or outdoors (see Fig. 2). The most convenient grounds are either the conventional station ground or a quarterwave ground wire laid on the ground (try it at various angles to the antenna).

An artificial quarterwave ground can be made by winding a halfwave of wire around a 6-foot length of 1" diameter wood dowel, using PVC-covered wire. This arrangement can work very well, providing that various positions and orientations are tried. I found that the best positioning is about 90 degrees to the feedline wire, either horizontal or vertical.

Yet another idea is to use a large metal frame window, a wire fence, or rainwater guttering or down piping, or just to drive a metal stake into the ground.

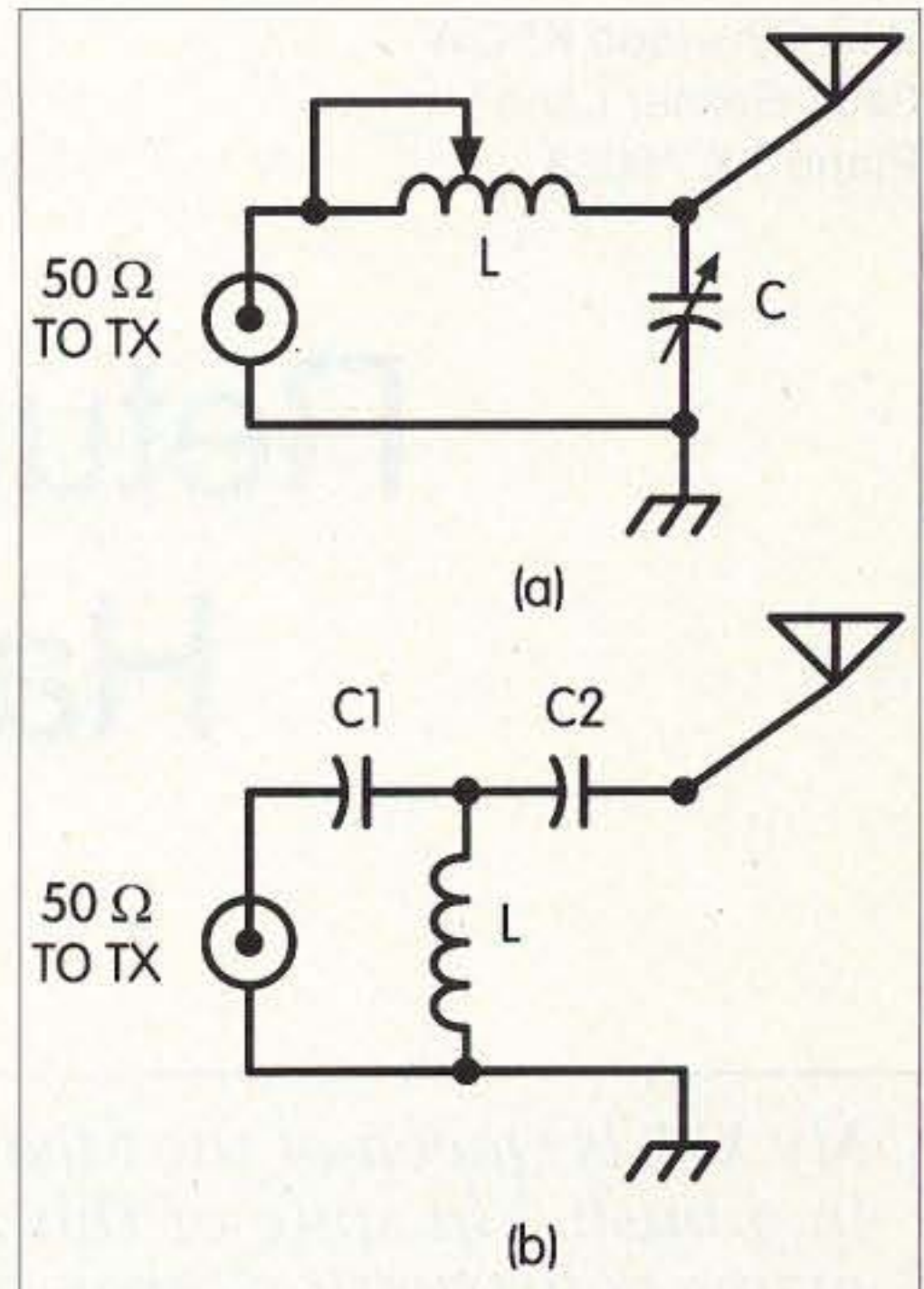

Fig. 3. Suggested ATUs. (a) L-C ATU. (b) T ATU.

**WARNING:** Do not use the house electrical wiring ground! The result will be at best to pump RF through the house wiring; at worst, it can be extremely dangerous.

When you are satisfied with the end result, helical winding L1 should be lap-taped with PVC tape and given a couple of coats of marine varnish (or similar) for weatherproofing. If the GPU 80 is to be hidden from hostile eyes in "antenna-hostile areas," then the PVC tape should be black, dark brown, or dark gray.

### Other bands

Using the LC ATU, it is possible to load the GPU 80 through the whole 3.5 MHz (80m) band, though only low power CW is used here. With a suitable LC ATU, the antenna will load effectively on the 7 and 14 MHz bands.

### Conclusion

The GPU 80 design, by necessity, contains many compromises. It is designed for horizontal, vertical, or sloping use, with a variety of grounding arrangements. It can be used outdoors or indoors, at vacation hotels or at portable sites. It can be packed up into a 6-foot length for transit or storage.

And it works! Somebody once said, "If an antenna works, it must be right." 73

# Return of the Amazin' Hall Tree Vertical

*This time, for 40/30.*

*My XYL is Queen of the Mixed Metaphor. She tells me that "hindsight is worth two birds in a bush." In spite of this sage advice, I cannot resist looking back over the years at many construction projects that were the result of my runaway curiosity. I am pretty much convinced that the old adage about curiosity and cats does not apply to us humans. It may be bad for felines, but as for me, it has taken me on many adventures. Here is one of them.*

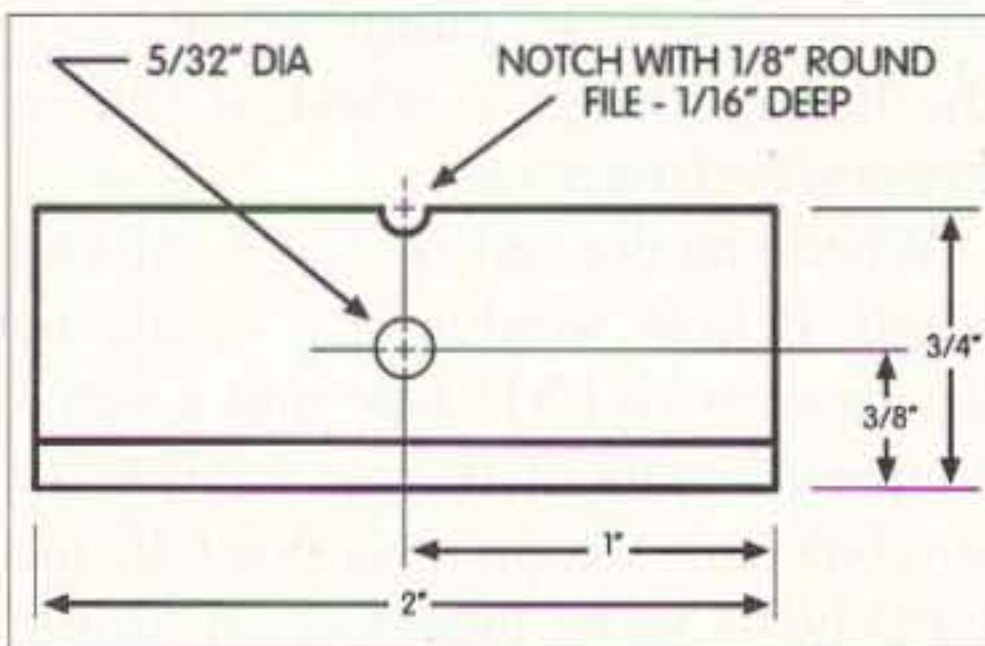

Fig. 1. Piece #1, made from 3/4" x 3/4" x 1/8" aluminum angle.

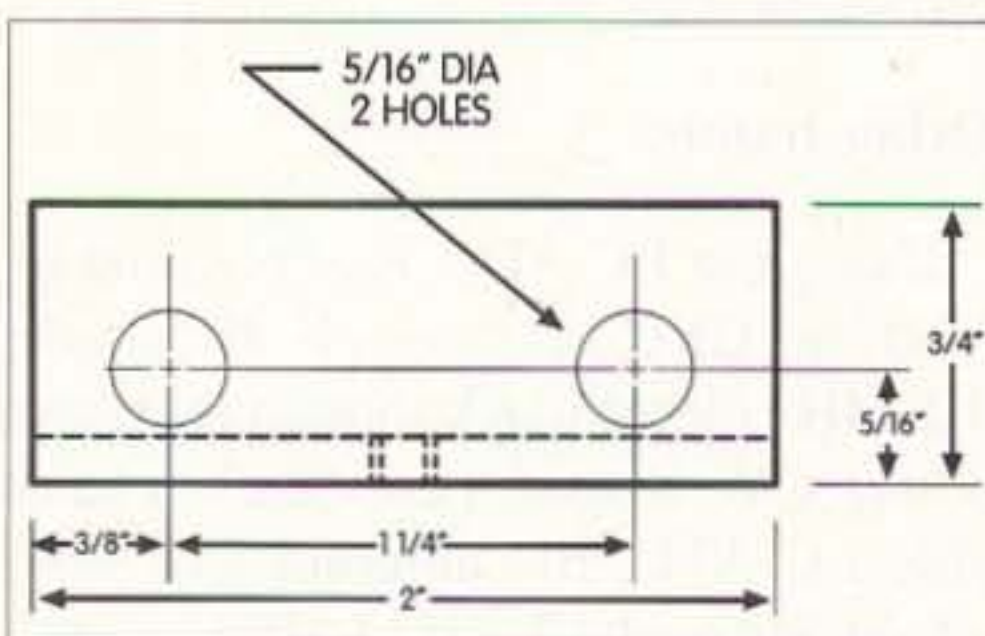

Fig. 2. Piece #2 (2 required), made from 2 Piece #1 turned 90 degrees.

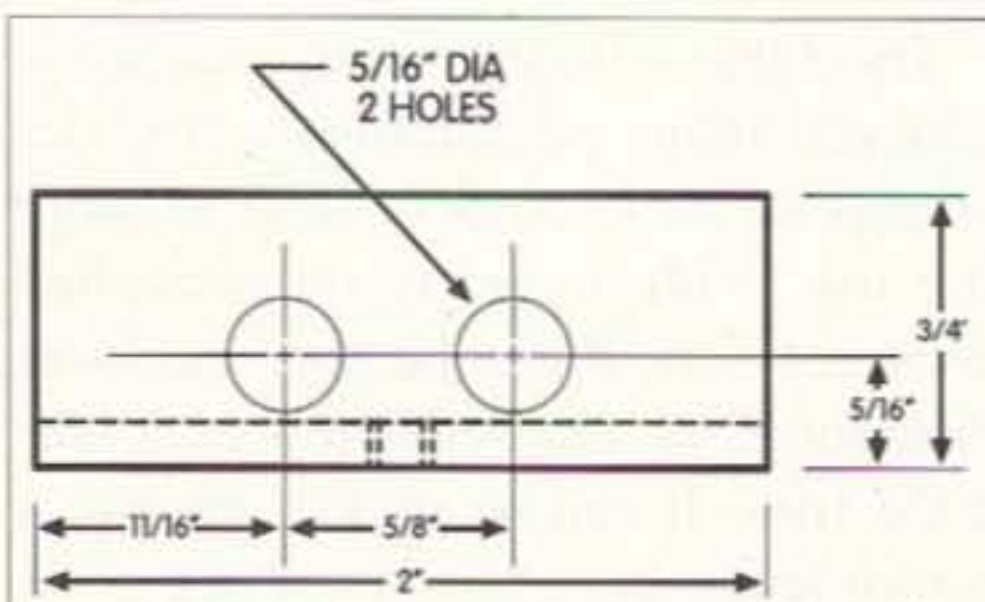

Fig. 3. Piece #3 (2 required), made from 2 Piece #1 turned 90 degrees.

A couple of years ago, a dear friend jokingly quoted a saying to me, to the effect that "no good deed should go unpunished." Remembering instances where this would seem to be true has seemed to temper my curiosity somewhat when contemplating a construction project that is motivated by trying to be helpful.

However, it seems that curiosity has overcome my good senses once again. The result is this 40 meter version of my Hall Tree Antenna that appeared in the March 1998 issue of *73 Amateur Radio Today*.

I don't consider myself a do-gooder, but do have compassion for those in situations that they do not like and can

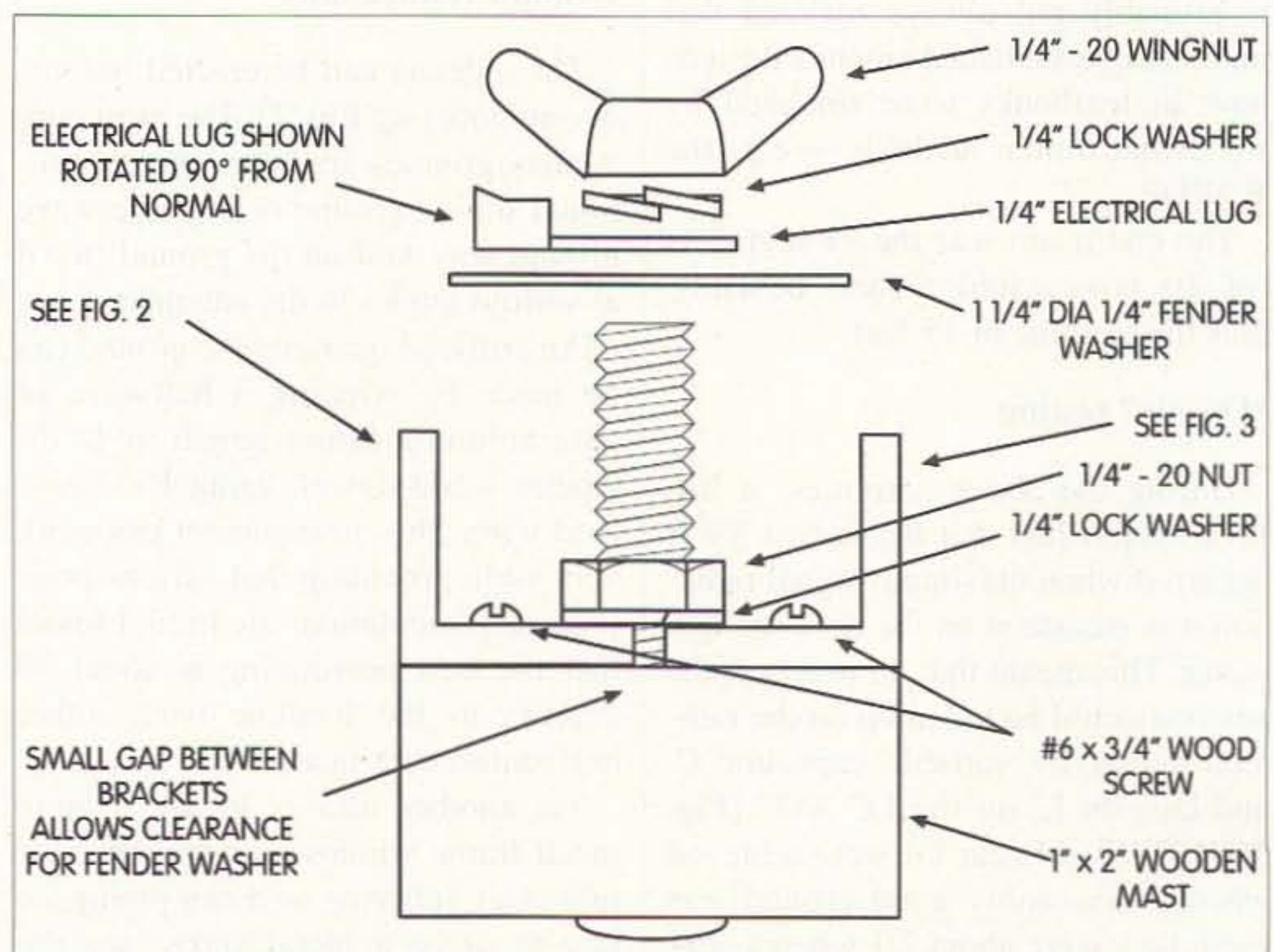

Fig. 4. Rod antenna mounting assembly (from the mast end).

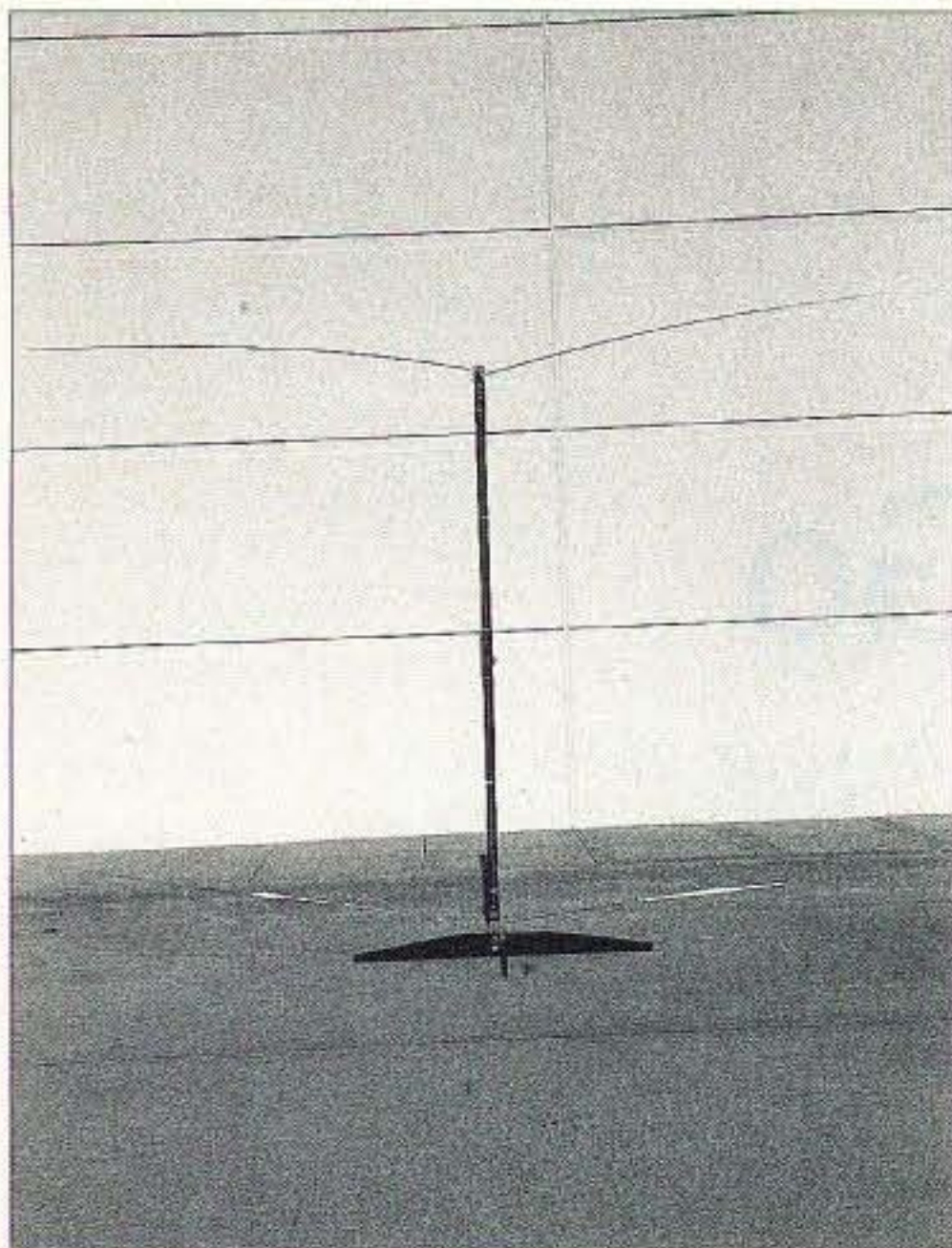

Photo A. The 40/30 Hall Tree Antenna.

do little about. Living in a community that has grown tenfold over a period of less than twenty five years, I find that it is not uncommon to hear the same story many times over on the local 2-meter repeater. An amateur wishing to operate on the HF bands bemoans the fact that he is party to a covenant with a home owner association that prohibits him (or her) from having a permanent outdoor antenna. It would not seem likely that something which is not permanent and could be erected or taken down in a few minutes (like lawn furniture) would be covered in these covenants.

The Hall Tree Antenna meets these requirements and may be of interest to some with this dilemma, as it can be unpacked and erected, erected or taken down, and packed up in less than 10 minutes. Because the original version only operates upward from 20 meters, it may be of little use after the Sun goes down, when many wish to operate. Even though it is not one of my favorite bands, my curiosity would not be satisfied until a 40 meter version was built and tried. Having a spare of the original model made the task easier and gave me an opportunity to review it and make some changes.

The most notable changes are the telescoping replacement antennas and their mounting. Two new mountings are required and each holds two removable, 6-foot (RS #270-1408) replacement

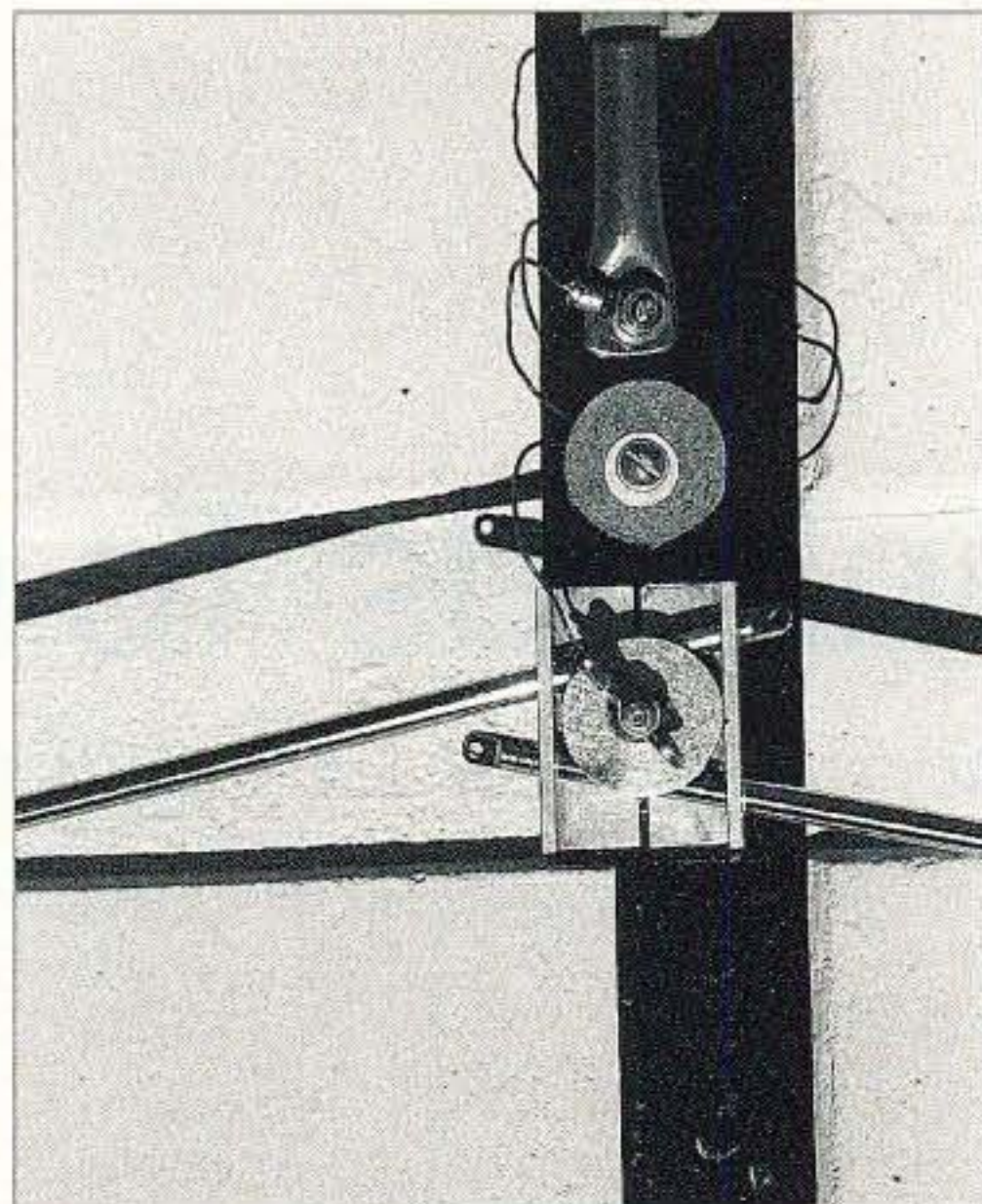

Photo B. View of the rod antenna mount with the masts folded.

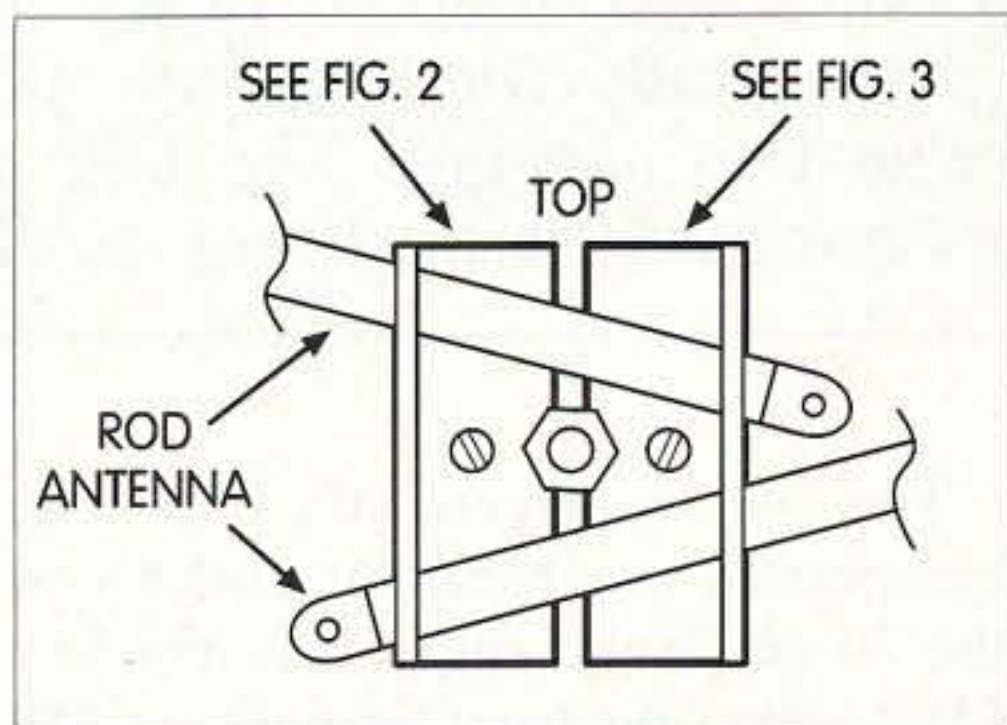

Fig. 5. Positioning of the rod antennas. Top view shown, with wing nut, lockwasher, lug, and fender washer missing.

rod antennas. In this design, they are intended to be inserted into each mounting and secured in place by a 1/4" x 20 center bolt, fender washer, and wing nut. When held horizontally, these antennas have the rigidity of overcooked asparagus. In order to prevent the lower elements from resting on the ground, the new mount points them upward at a somewhat rakish angle of 15 degrees. Unlike the original version, all the elements are operated horizontally. Adjustment is still the same; the upper elements are fully extended, and tuning is done by equally adjusting the lower antenna lengths.

In order to accommodate the new mountings, changes were made in some dimensions of the upper and lower masts. The balun coil is the same as in the March 1998 article, but the balun coil (with insulation) and SO-239 connector are now mounted

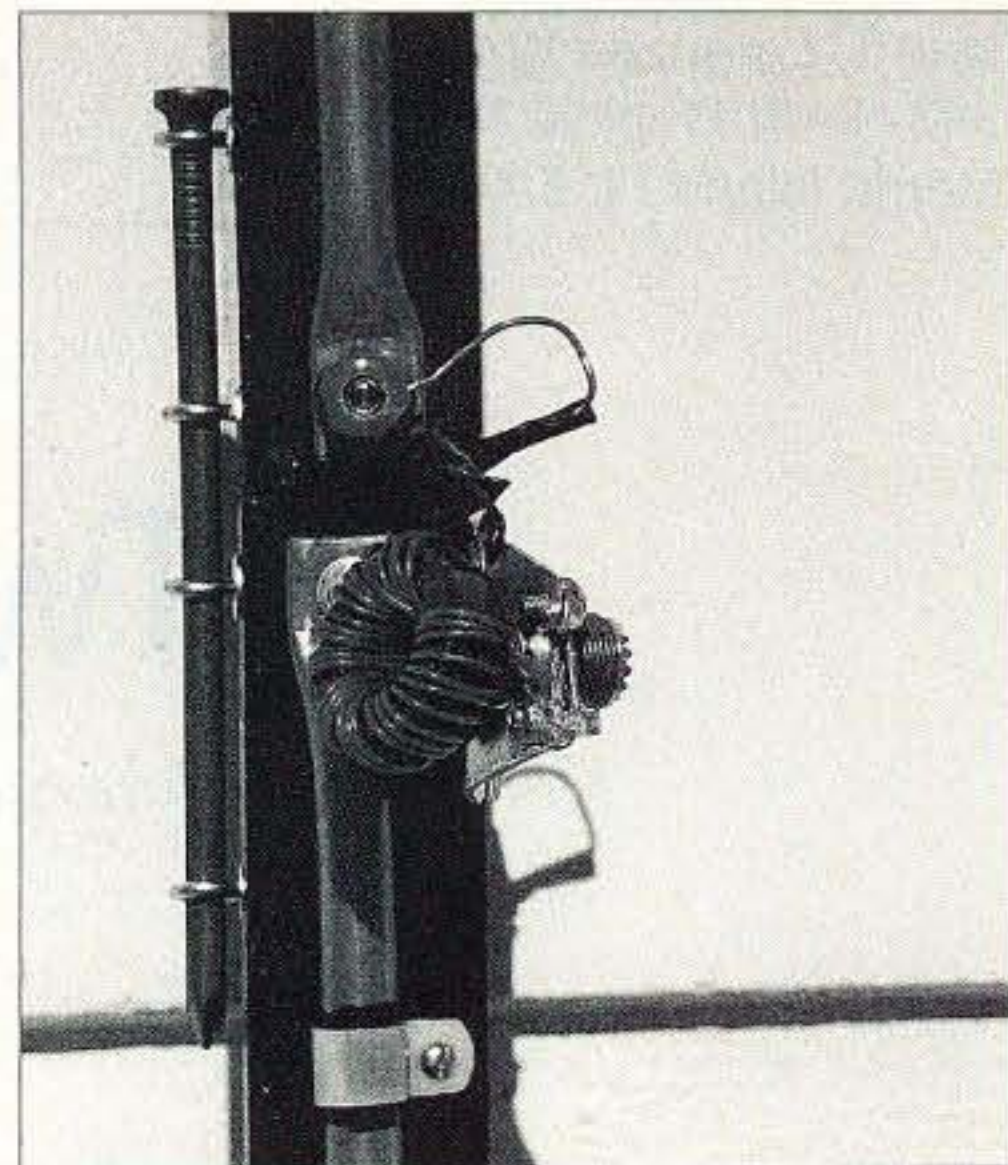

Photo C. The center, showing SO-239 connector, pigtail lead from balun, and binding post connection.

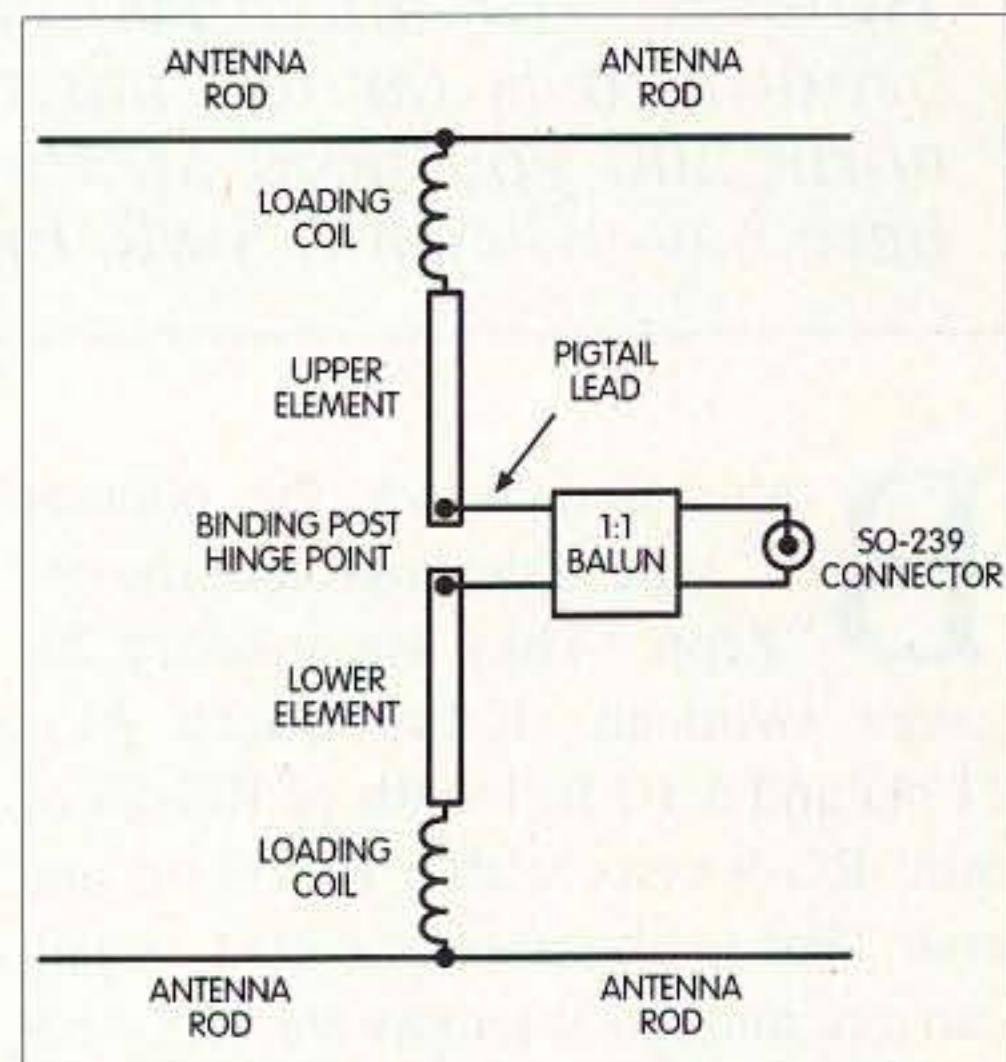

Fig. 6. 40/30 meter antenna schematic.

on a 2" x 4" piece of 1/8" aluminum. This is fastened to the side of the mast (see photo). The 1" x 2" wooden mast lengths are changed. The upper mast is 43-1/2" and the lower mast is 47" long. The 3/4" or less (not critical) diameter copper elements are now 39" long.

Intended for single band operation, each of the two loading coils consists of a single winding of 30 turns of #18 insulated copper wire wound on Amidon Associates T-106-6 powdered iron toroidal cores. For 30 meter operation, 27 turns are needed. Each is secured to each mast with a 1-1/4" wood screw and insulating washer made from 1/4" tempered Masonite.

Any shortened ground-mounted version of a dipole antenna operated amid

Continued on page 57

# Twinleads To Go

*Keep these emergency antennas for 2m and 70cm in your glovebox.*

*Twinlead VHF antennas have been described in many articles, but far too often the bandwidth is far too narrow, especially for emergency use where low power is the norm and you need all the edge you can get. The VHF and UHF antennas described here have very low SWR, broad bandwidth, and they really work.*

**B**oth antennas are the popular "J" type, a derivation of the old "Zepp." They use ordinary 20-gauge twinlead (Radio Shack #15-1174) and a 10-ft. length of RG-58 or mini RG-8 coax with a PL-59 on one end. That is about as low-cost as you can get, and the antennas are very easy to make.

The 2-meter antenna can, of course, be operated as a harmonic antenna on the 70 cm. band, and it has very low SWR across the band from 430 to 450 MHz. Just bear in mind that harmonic antennas have their major lobe of radiation up at an angle instead of toward the horizon where you really want it. For this reason, data is given for a 70 cm. antenna operating on its fundamental resonant frequency.

## Two-meter antenna

An MFJ-249 SWR analyzer was used to determine the final dimensions on the 2-meter antenna, and the SWR readings were 1:1 at 146 MHz and 1.2:1 at 144 and 148 MHz.

Antennas are affected by objects in their immediate environment, so your results may vary a little from mine, but they should not differ greatly. During the tests, the antenna was hung by a nylon cord about 6" below a tree limb, and the bottom of the antenna was about 3 feet above the ground.

The SWR readings were virtually the same across the band when the antenna was connected through a Radio Shack #19-320 VHF/UHF SWR meter

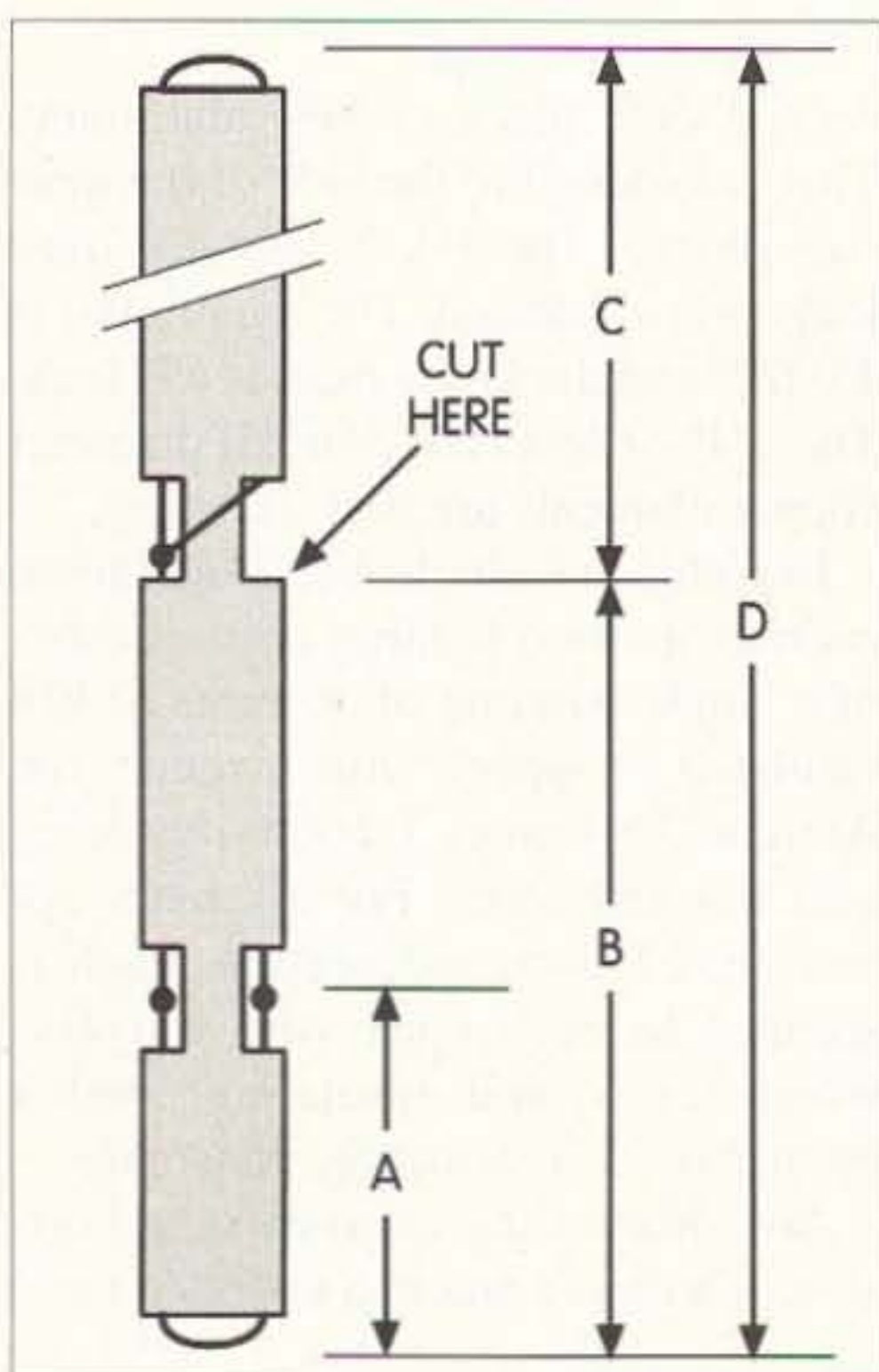

Fig. 1. Antenna layout.

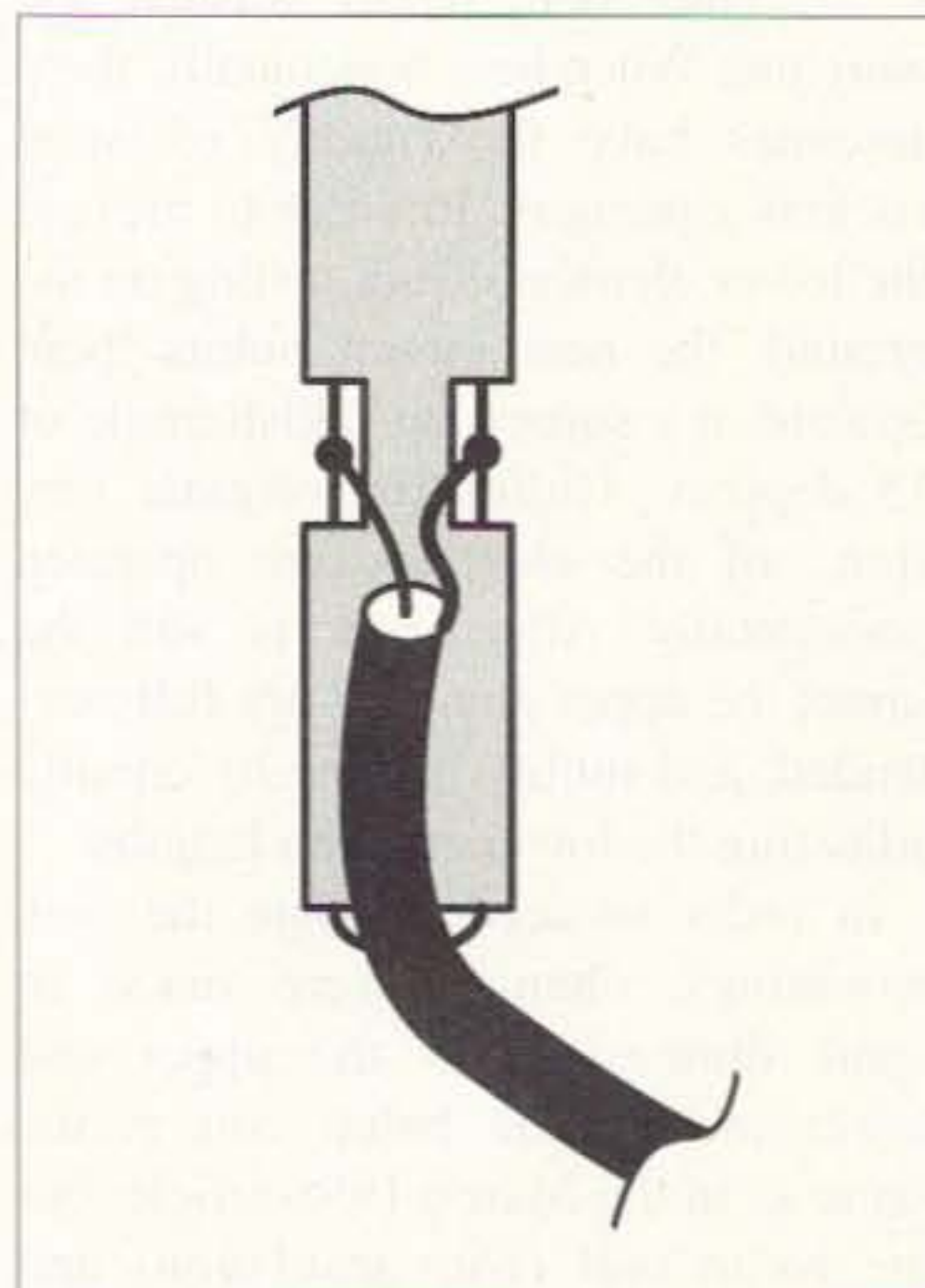

Fig. 2. Detail of the coax connection.

Ant. Freq.	Dimensions, inches			
	A	B	C	D
144-148 MHz	2-3/8	17-1/2	30-1/2	48
430-450 MHz	1-3/16	5-3/4	11-1/2	17-1/4

Table 1. Dimensions for the twinlead antennas.

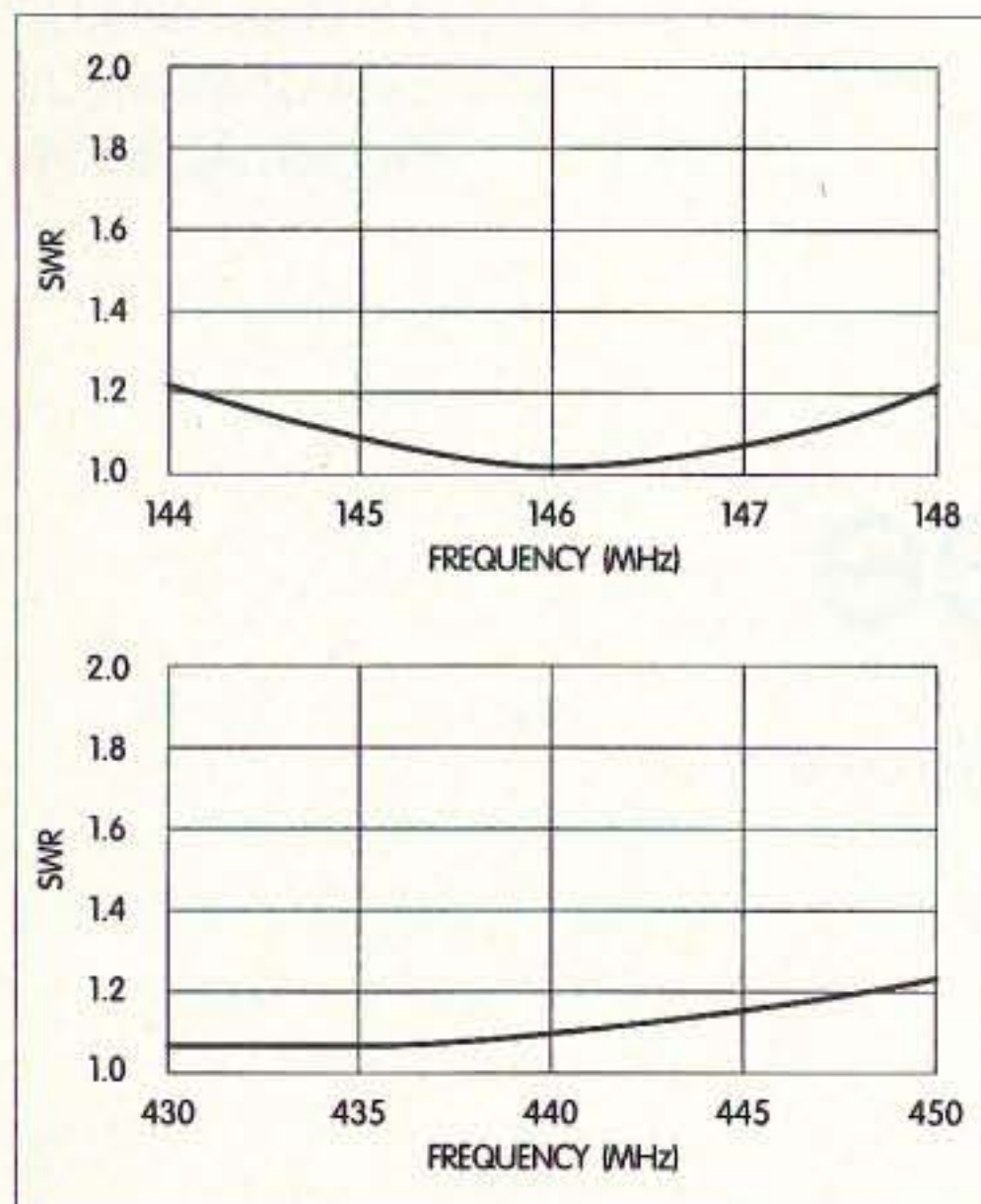

Fig. 3. SWR charts for the 2m twinlead antenna.

to a RS HTX-202 transceiver. The SWR meter was mounted directly onto the transceiver with a BNC/SO-239/dual PL-259 adapter. In addition to local area repeaters, I was easily able to reach systems that were 25 miles away. The MFJ-249 doesn't reach 450 MHz, so I used a RS HTX-404 transceiver to check the 2-meter antenna on this band. Mounting the VHF/UHF SWR meter directly onto the transceiver gave me SWR readings of 1.1:1 at 430 MHz, rising gradually to about 1.25:1 at 450 MHz.

### 70cm antenna

Lacking an SWR analyzer for this band, I used the RS HTX-404 transceiver and RS #19-320 SWR meter to arrive at the final dimensions. The antenna was hung in the same position described for the 2-meter antenna. The SWR readings were virtually flat 1:1 across the band from 430 to 450 MHz. I again raised repeaters some 25 miles away, with good signals in both directions.

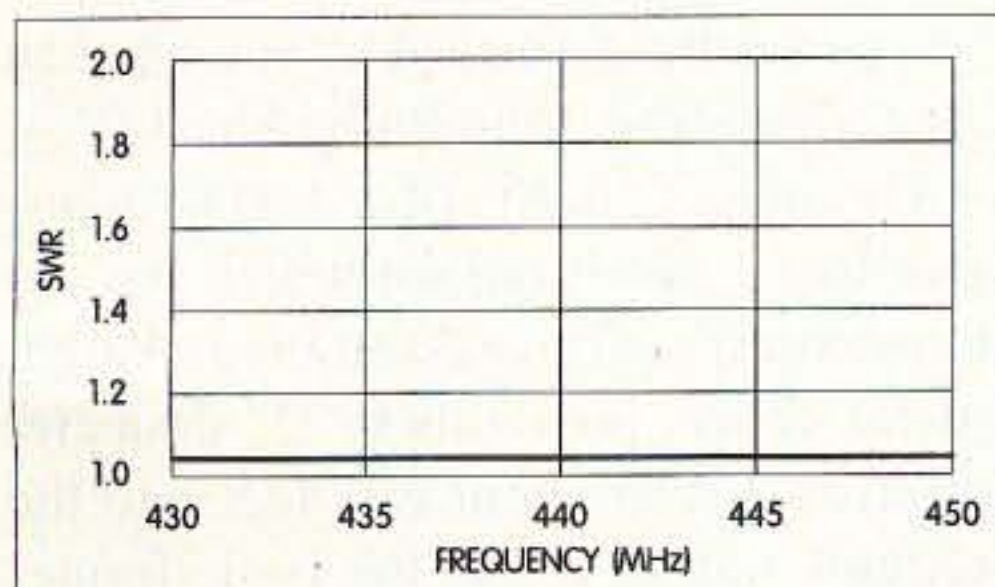

Fig. 4. SWR chart for the 70cm twinlead antenna.

### Construction notes

Layout data for both antennas are given in Figs. 1 and 2. Dimensions are given in Table 1.

Lay the twinlead flat and straight so that the measurements will be accurate. The quarter-wave matching section, dimension "B" in Fig. 1, is very critical in that a small change in this dimension results in a significant change in the frequency at which minimum SWR occurs. For example, on the 2-meter antenna, if you find that the SWR is higher at 144 MHz than it is at 148 MHz, the matching section "B" is too short. If the SWR is higher at 148 MHz than at 144 MHz, the matching section "B" is too long.

Strip the plastic insulation away, as shown in the drawing, using a knife or small soldering iron. On the 70cm antenna, remove all of the plastic between the shorted end and the coax connection points.

The cut wire is connected to the radiator element at both the top and bottom to eliminate a floating wire, and it effectively makes the radiator fatter, which helps a little to broaden the bandwidth. It also provides a loop at the top for hanging the antenna.

The coax is centered in the middle of the stub and lies directly against it. A #18 solid copper wire is connected as a jumper from the coax braid to the cut side of the matching section.

Both the hot end and the coax end of the matching section are taped using clear, transparent packaging-type tape. Use only a couple of wrap-arounds, just enough to provide a little stiffening. Don't overdo it. There was no noticeable change in readings after the tape was applied.

### Conclusions

Simply because of responses to previous articles, it may be appropriate to add a little explanation. The absence of math, formulas, velocity factors, etc., is no accident. All of these are good, even necessary, as starting points. But when you embed antenna wire in plastic it becomes necessary to go to the "empirical" solutions. That's just a two-dollar word for cut, try, and adjust,

again and again and yet again. Sometimes antennas are not "designed" — they are arrived at. 73

**HamCall™ CD-ROM**  
U.S. & International - Over 1.5 million listings

*We make a new HamCall every month! Clearly, the most comprehensive and current CD-ROM available.*

**Latest Features**

- Choose font and color of data display.
- Displays flag and map for each country.
- Shows CQ, ITU zone, and continent.
- History list shows each callsign entered.

View & search interests of 26,000 hams.

- Search for club, military, RACES, vanity, silent keys, name, address, and more.

Over 1,566,000 U.S. and International listings, 104,000 e-mail addresses, 4,000 photos and QSL cards, 30,000 vanity calls, and 12,000 references to QSL managers.

- Shows short & long path distance & bearing.
- Precise latitude/longitude for over 90% of addresses.

HamCall is \$50.00, included is 6 months free access to our Internet Search Service - request when ordering.

---

*HamCall Mousepad*, with morse code reference, 7.5" x 8", blue with yellow letters. \$5.00+ \$3 shipping.

---

\$5.00 shipping per order. Your satisfaction guaranteed!  
Free 800 technical support - we won't let you fail.

**BUCKMASTER**

6196 Jefferson Highway • Mineral, VA 23117 USA  
e-mail: info@buck.com www.buck.com  
540:894-5777 • 800:282-5628 • 540:894-9141 (fax)

**CAPTURE IMAGES LIKE THIS DIRECTLY FROM SPACE ON YOUR PC!**

- Internal Systems and Portable, External (Parallel Port) Systems Available for IBM Compatibles.
- Capture Full Satellite Resolution (2-3 Miles with NOAA Satellites!) with Either System.
- Professional Software with "Point and Click" User Interface, Mouse Support, Satellite Tracking, Zoom, GIF and Binary Output, False Colorization, Printer Support, Grid-ding, IR Temperature Calibration, Animation, Much More...
- PLL Circuitry Automatically Provides Ruler Straight Images. No Complicated Timing Settings Required.
- Simple Antenna Used for NOAA and Meteor Satellites. NO Dish Required.

- SVGA to 1024x768x256.
- Receive High Resolution Images from NOAA, Meteor (Russia), GOES, and Meteor-sat Satellites, and HF Fax.
- Receivers, Antennas, Downconverters, and Feed-horns also Available Separately or in Complete Systems.
- Internal Demodulator with Software only \$289. Multi-FAX Programmable Satellite Receiver. Just \$249!
- Call, Write, or Fax for Complete Information. Download the above and dozens of other images (as well as software and current orbital elements) from our web site at [www.multi-fax.com](http://www.multi-fax.com)

**MultiFAX®** 30 Steele Road  
Victor, NY 14564  
Voice: 716-425-8759(BBS after 5PM) Fax: 716-223-6198

# The Hybrid Vee

*Revisit the original Taylor Vee — and improve it.*

*You may recall "Charlie" Taylor's "The Taylor Vee 20m Antenna" article that appeared in the May 1998 issue of 73 Amateur Radio Today: a rotatable twenty-meter inverted vee that was intended to solve the average radio amateur's problems of limited real estate and difficulty of adjusting the antenna for minimum SWR.*

In the new Taylor Hybrid Antenna, Charlie has revisited the general principles of the original Taylor Vee, but moved one leg of the vee to a vertical position parallel to the supporting structure. Charlie's reasoning is that a strong vertical component of radiation, as well as the expected horizontal component from an inverted vee-type antenna, will improve the antenna's DX capabilities ... and so it has turned out.

Reference to the original article will show virtually all of the construction features, procedures and materials of the hybrid antenna as well, except for some added details of the vertical element. However, for those who don't have the original article available, a complete description of the Taylor Hybrid Antenna follows. Please refer to the figures as you read the description.

## Description

Inverted vee antennas generally exhibit maximum horizontally polarized radiation at right angles to the plane of the antenna, while fairly deep nulls exist off the ends. The hybrid antenna is intended to overcome this apparent deficiency by providing significant vertically polarized radiation from at least one end of the antenna, without sacrificing the other desirable features of the original Taylor Vee. In addition, the Taylor Hybrid reduces the "wing-span" of the original by half, making it even easier to install on a small lot.

The hybrid antenna is mounted on a framework consisting of a length of 2" x 2" lumber, a length of PVC pipe, and a length of metal chain-link fence rail. (See Fig. 1.)

The entire assembly is light enough to be rotated by a small TV-type antenna rotator available from Radio Shack™.

The mast consists of a 1-1/4"-diameter metal fence rail on which the antenna framework is assembled. A light metal fence post (about 2"-diameter pipe) is driven about two feet into the ground and serves as the basic framework support. The TV rotator is mounted at the top of the fence rail



*Photo A. The tuning stubs are tough to see in these photos, but give it a try.*



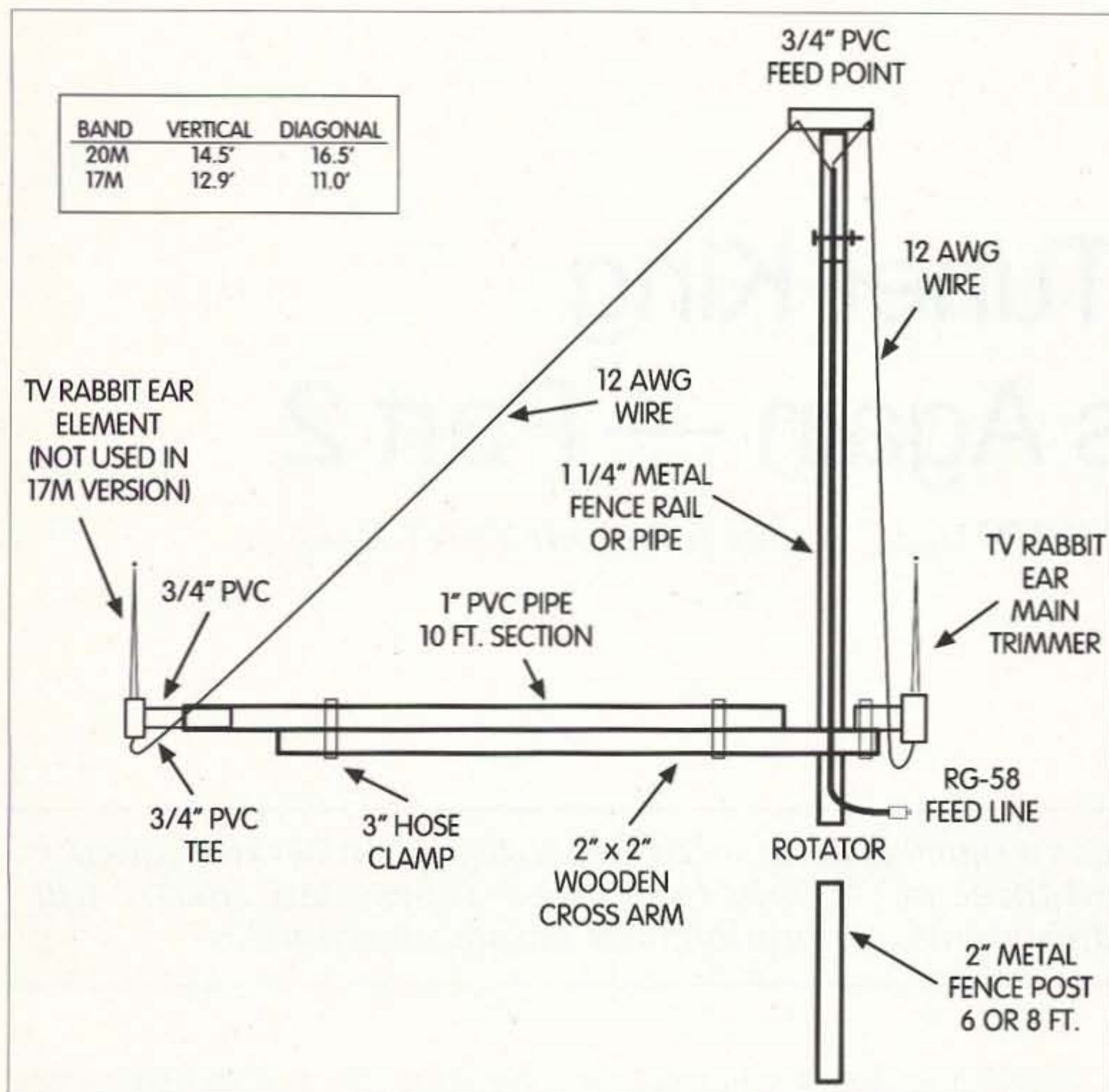

**Fig. 1.** The 17 or 20 meter Taylor Hybrid Antenna, showing a tuning stub for both the vertical and slanted wires.

(about 6 feet above ground). The entire antenna assembly and support frame is mounted to the TV rotator.

Clamp the 10-foot section of 1-1/4" diameter fence rail into the TV rotator. A single length of 3/4"-diameter PVC pipe is slip-fitted into the top end of the fence rail, leaving about two feet

extended from the top of the mast. Drill through the mast and PVC pipe for a bolt to secure them together. At the top of the two-foot PVC pipe extension, place a 3/4"-diameter PVC pipe tee, which becomes the hybrid antenna feedpoint.

Just above the TV rotator, and on

Mast	1-1/4" x 10-ft. chainlink fence rail
Boom	One 8-ft. length 2" x 2" lumber
	One 10-ft. length 1"-diam. PVC pipe
1	10-ft. length 3/4"-diam. PVC pipe (to be cut to needed lengths)
2	TV rabbit ears or telescoping whips
3	3/4" PVC pipe tees
2	TV U-bolts
THNN #12 AWG insulated wire sufficient for desired number of antennas	
1	TV antenna rotator
RG-58 C/M coax (suitable length, antenna to shack)	
Misc. nuts and bolts	
1	2"-diam. metal fence post

**Table 1.** Parts list.

one side of the mast, mount a horizontal antenna support (or "boom" in sailboat terms) consisting of a ten-foot, 1"-diameter PVC pipe firmly attached with 3" hose clamps to the 2" x 2" length of lumber. The inner end of the 2" x 2" lumber is drilled to accept a U-bolt which secures it to the mast.

Further extend the outer end of the PVC pipe by slip-fitting into it a three-foot length of 3/4"-diameter PVC pipe. Then attach, in an upright position, a 3/4"-diameter pipe tee to the end of the

*Continued on page 57*

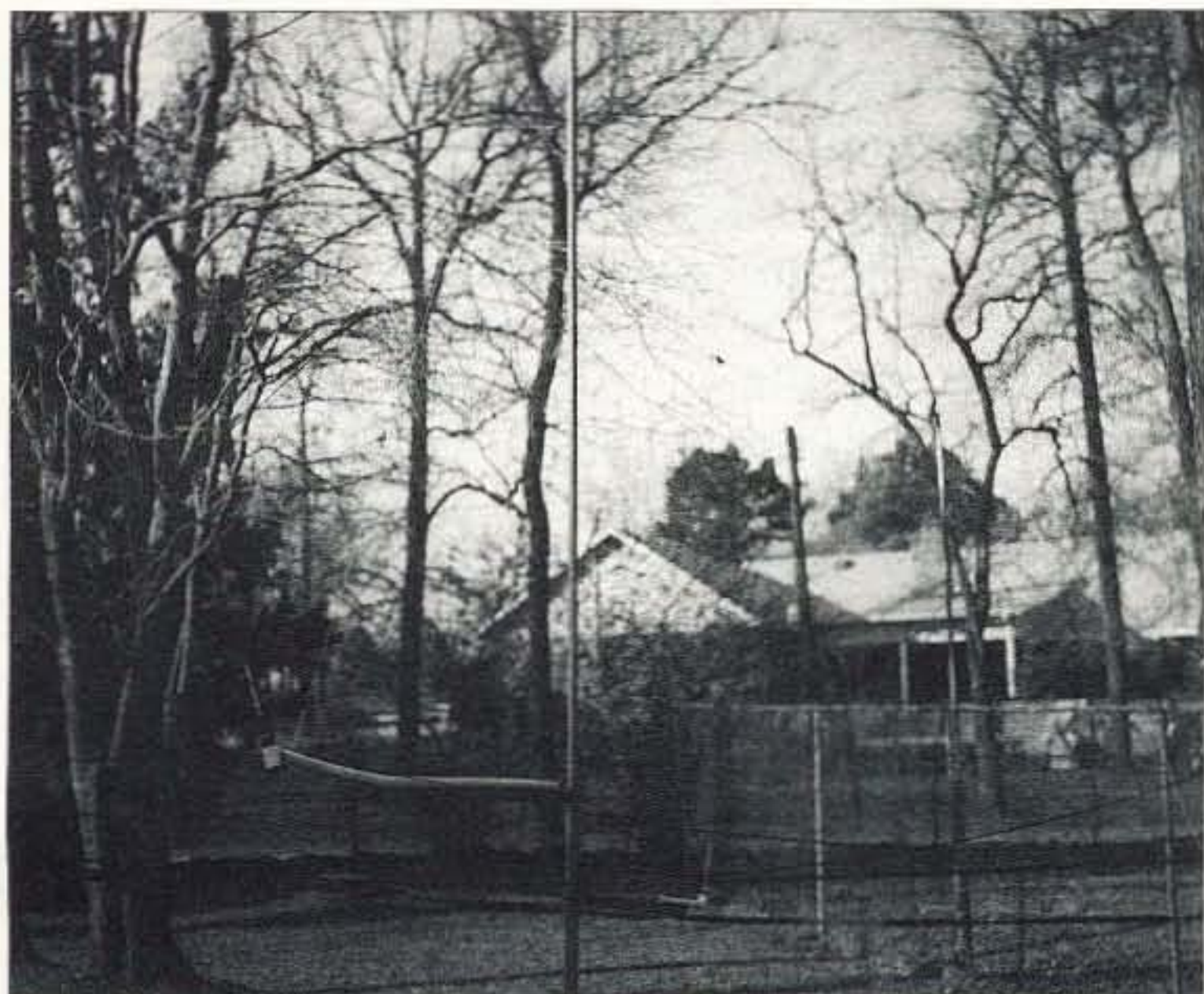

**Photo B.** Another chance to spot the stubs — but you get the idea.

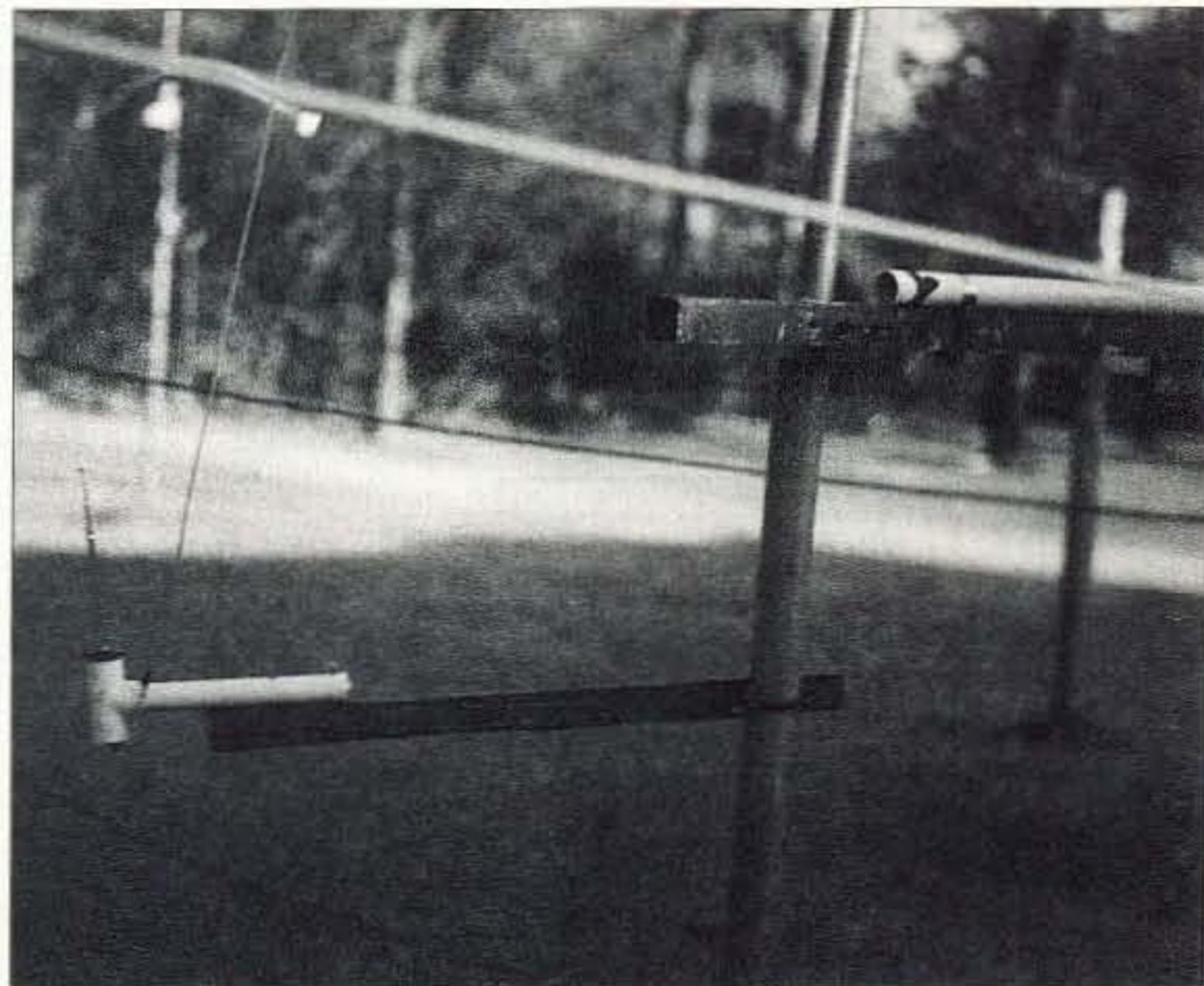

**Photo C.** Close-up of stub.

# Tuner King Strikes Again — Part 2

*Make a basic VHF/UHF signal source from your TV/VCR tuner.*

*Part 1 of using a TV/VCR tuner as a signal generator covered a discussion of the frequency range, tuner connections, and three of the four basic tuner types. Here, part 2 will continue with tuner types, adjustments, calibration, and output amplitude.*

**T**uner type IV. If only a UHF signal generator is required, then a mechanical variable UHF tuner (Fig. 1) will work well in your application. The typical tuning range of the oscillator is 480–900 MHz, but that range can be modified to cover a higher top end or a lower bottom end. However, both an increase in the upper frequency and decrease in the lower frequency to widen the tuning band are not likely.

Tuning to a specific frequency is somewhat difficult because of “fast” tuning. If the tuner has an AFC/AFT terminal, then fine tuning can be implemented. A potentiometer-controlled voltage (typically 2 volts maximum) is applied to the AFC-AFT terminal.

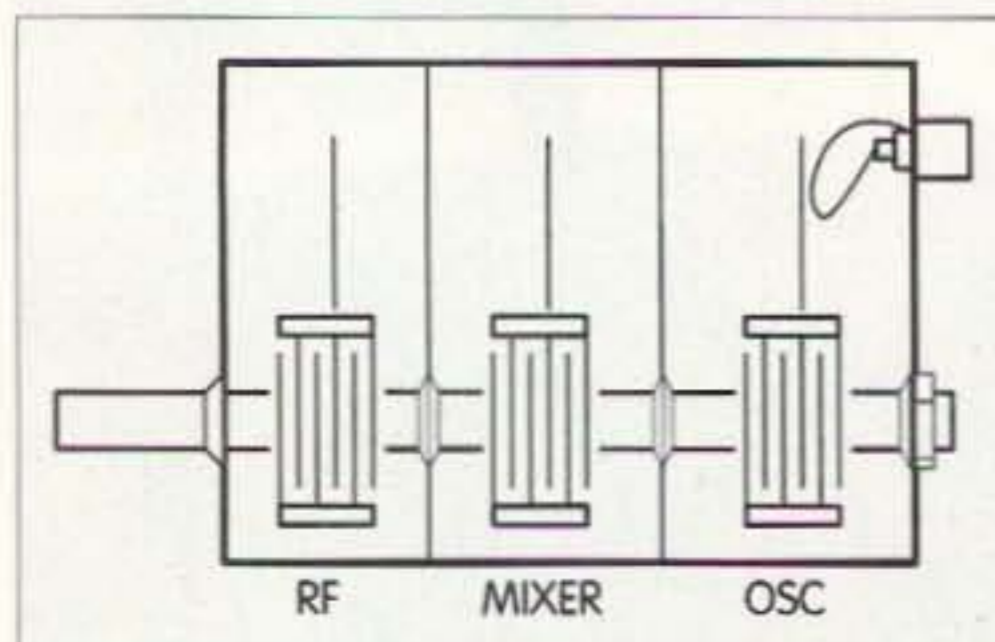

Fig. 1. Mechanical variable UHF tuner with placement of an oscillator pickup loop.

Should it be desirable to move the oscillator's tuning band, built-in adjusters are available. Mounted alongside the resonator is a loop of wire that is grounded on both ends. The loop functions as an inductor that is in shunt with the resonator. Moving the loop closer to the resonator will raise the frequency of oscillation, and moving the loop away will lower the frequency.

In addition, some tuners have a metal paddle mounted adjacent to the variable capacitor. The paddle functions as one plate of a capacitor and is used for top capacitive loading on the resonator. Moving the paddle closer to the variable capacitor lowers the frequency, and moving it away will raise the operating frequency.

Increasing the top loading of the resonator may also be accomplished by placing a low value trimmer capacitor (0–12 pF) between the oscillator's variable capacitor and the top edge of the tuner's case. The addition of top loading will, in addition to lowering the operating band, also narrow the total tuning range.

If the desire is to lower the operating band, then wire jumpers should be installed in both the RF and mixer

circuits to prevent them from interfering with the oscillator through RF energy absorption. Lowering the frequency of the oscillator will place it within the tuning band of the RF and mixer circuits.

## Adjustments and calibration

Adjustments to a tuner involve modifications required to shift the operating frequency range and installation of the pickup loops. The important first step is to measure the oscillator frequency range as it exists before modification. A frequency counter can be used to measure the frequency.

Place the counter's antenna close to, but not touching, the oscillator's resonant circuit or attached directly to the signal output connector. Because each tuner design is different from the next, I can only provide suggestions as to suitable methods for shifting the frequency range of the oscillator. But if shifted lower by at least 47 MHz, the RF and mixer resonators will cause an interference problem. The RF and mixer resonators in the electronically tuned tuners may be disabled by shunting the “hot” end of each of the resonators to ground with a large value

capacitor such as a 0.01  $\mu$ F. A capacitor is suggested because a jumper wire might ground out the varactor bias if it exists on the resonator.

The UHF oscillator is the easiest to move, because adjustment devices are designed into the tuner for that purpose. Alongside the resonator is either a wire loop (inductor) or a metal paddle (capacitor). These devices can be identified by inspection. Moving the loop or the paddle closer or farther away will shift the operating frequency band.

Adjusting the frequency of the VHF band oscillator presents a greater challenge than the UHF. Coils are used for the VHF low and VHF high resonators. In most cases, the coils appear to be mashed, and they were mashed intentionally to shift the tuning range to cover the TV band. Some band shift in tuners may be accomplished by squeezing the turns closer or separating them. Adjusting the coils doesn't accomplish very much, so leaving them alone is my best advice.

When coupling loops are being used, they should be in their final position before making a final frequency chart. Positioning the coupling loop involves finding the best position of the loop to achieve maximum output. Monitoring the relative output level can be accomplished with a peak detector and a sensitive indicator as shown in Fig. 2. My preference has

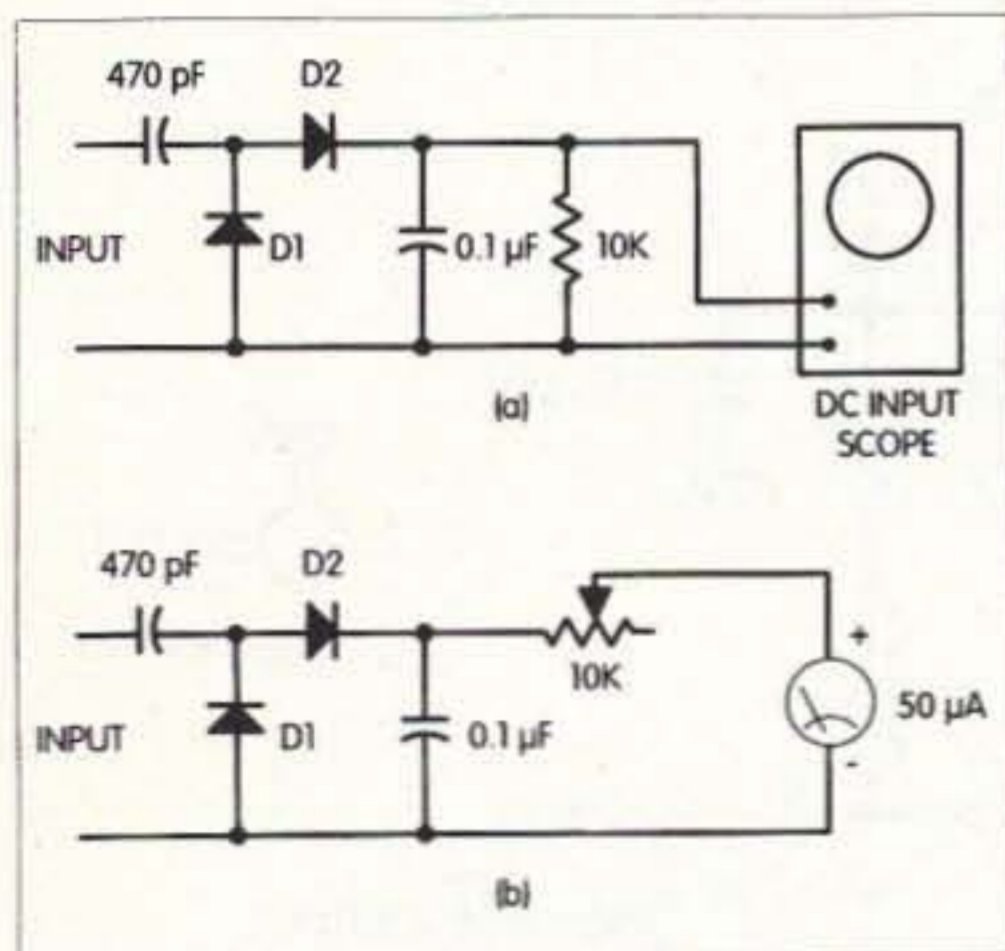

Fig. 2. RF peak detector and sensitive indicator used for adjusting the output coupling loop. Circuit (a) uses a DC input oscilloscope as an indicator, and (b) uses a sensitive microammeter as an indicator. D1 & D2: 1N34, 1N82, 1N295 or equivalent point contact RF diode.

been the use of a DC input oscilloscope, as it operates at a lower indication threshold than a meter.

I've found that operating the oscillator at the lowest frequency in each band works best while initially positioning the loop. When the optimum position has been found, then shift the frequency to the high frequency end for a final tweak of the loop position.

Once the resonators and loops have been adjusted as desired, a counter may be used to measure the frequency of the oscillator as a function of tuning voltage. Setting up a frequency chart in either 0.5 or 1.0 volt steps is a suitable starting point for calibration. A smaller voltage step may be used for specific band segments. As a suggestion, a frequency vs. tuning voltage curve for desired band segments may be plotted on graph paper. A full range chart is shown in Fig. 3. The graph becomes a useful "tool" for tuning the signal source to specific ham band frequencies.

### Output amplitude

The direct output amplitude from tuner oscillators is suitable as a signal source for receivers and other high impedance applications. As a caveat, the output amplitude across the tuning band will vary because there is no built-in signal leveling.

Table 1 shows the RMS voltage amplitude that I obtained from one tuner with and without an amplifier, but the data is representative of what other tuners exhibit. The pick-up coupling factor has a direct affect on the signal

output amplitude, and that's why the loop needs to be adjusted with care.

If a higher signal amplitude and/or higher output power is required, then

### WANT TO LEARN CODE?

Morse Tutor Gold from G.G.T.E. is the answer for beginners and experts alike.

\*Get the software the ARRL sells and uses to create practice and test tapes; and Morse Tutor Gold is approved for VE exams at all levels.

\*Since 1987, GGTE has guided nearly 20,000 hams and prospective hams around the world through proven structured lessons and a variety of character, word and conversation drills. Straight forward menus make the process simple and fun.

\*This program features easy and speedy self installation; random character drills with the characters you select; and you can create your own drills or import text files. You can type what you hear or copy by hand and see the results one line at a time. Pick the Farnsworth or the standard method; select the tone frequency most comfortable for you or select your code speed in tenths of a word per minute. For all DOS computers. You are always in command.

Certified by



Morse Tutor Gold uses your internal speaker or sound board. And, if you use a sound board Morse Tutor Gold supports volume control.

Sound Blaster and the Sound Blaster Compatibility Logo are trademarks of Creative Technology Ltd.



Available thru dealers, the ARRL, or send \$29.95 + \$4 S&H (CA residents add \$2.32 tax) to: GGTE, P.O. Box 3405, Dept. MS, Newport Beach, CA 92659 Specify 5 1/4 or 3 1/2 inch disk.

CIRCLE 193 ON READER SERVICE CARD

### IN STOCK ... at your FAVORITE Amateur Radio Dealer



A new Dual Element Studio Microphone with full range, smooth, articulate response. Great for broadcast quality SSB, AM or FM. Wide 60 to 16kHz response with a +4dB peak at 2kHz - so important for well balanced articulation while at the same time producing a robust 'big bottom' low end.



5/8-27 thread mic. clip supplied

### Hi-Fi SSB! FULL Range Dual Element GOLDLINE Studio Microphone

The GOLDLINE is equipped with the new full range studio cartridge element plus your choice of the HC-4 DX DREAM MACHINE or the HC-5 Mid-Range element - switch selectable for tough or normal band conditions. Features a new 'soft touch' PTT microswitch for smooth and reliable operation.

HEIL Model	
GM-4 with Full Range/HC4	\$139 <sup>95</sup>
GM-5 with Full Range/HC5	\$139 <sup>95</sup>
GM-V 'VINTAGE GOLDLINE' w/built-in matching transformer for use with those older hi-Z 'boatanchor' inputs	\$159 <sup>95</sup>
CC-1 Connecting Cable for Icom, Kenwood, Yaesu or TenTec radios	\$29 <sup>95</sup>

### HEIL SOUND

5800 N. Illinois  
Fairview Heights, IL  
618-257-3000

www.heilsound.com

### HEIL SOUND

Defining the Standard for Amateur Radio Communications

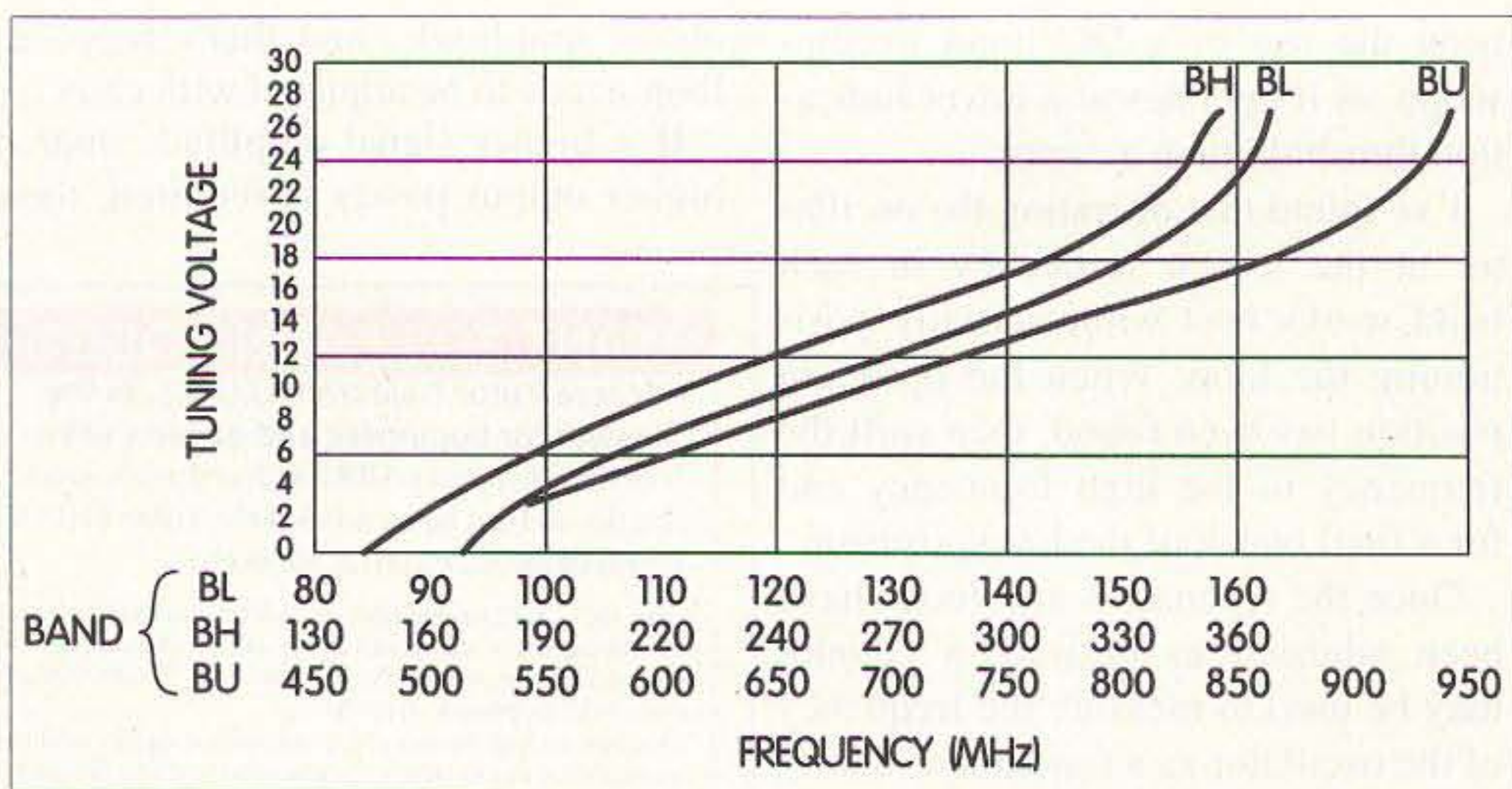

Fig. 3. Typical graph that translates between tuning voltage and frequency for three tuner bands.

an amplifier may be added into the output circuit. I've been using an NEC UPC1651G MMIC as an output amplifier, and it has provided reasonable results even though it exhibits some gain rolloff as 900 MHz is approached. Within the dynamic range of the MMIC, I've realized a voltage gain up to 10:1. However, there is a gain variation vs.

frequency issue due to the amplifier layout that could be "fixed" with some design considerations.

Although I'm experimenting with the more readily available Mini-Circuits MAR3 device, the final results are not complete. However, the use of the MAR3 device is promising.

Both the NEC and MAR3 devices will drive a 50 ohm source quite well, if that's a requirement. Fig. 4 shows the schematic for both devices and the use of a 500 ohm potentiometer that is used as an output level control.

### Conclusions

If you've been in need of a VHF/UHF signal generator, perhaps a TV/VCR tuner modified to function as a signal generator will meet your needs. The internal oscillator of a tuner will generate a signal in the range of about 90 to 900 MHz. Although there are holes in the tuning range,

the frequency coverage is very useful.

The output amplitude, though adequate for many applications, may not be as high as some projects require. A MMIC amplifier may be added into the output circuit to increase the tuner's output amplitude by as much as ten times.

	Freq. (F)	Volts (E)	Volts (E)
Band	Osc	Direct	Amplifier
BL	96 MHz	500 mV	2000 mV
	187 MHz	700 mV	1100 mV
BH	146 MHz	350 mV	1400 mV
	345 MHz	300 mV	600 mV
BU	466 MHz	5 mV	300 mV
	950 MHz	10 mV	100 mV

Table 1. Relative RMS voltages values obtained from one tuner modified to be a signal generator. Data is shown with and without an amplifier. A load impedance approaching 1000 ohms was used during the measurement.

EVERY ISSUE OF  
**73 Amateur Radio Today**  
on Microfiche!

The entire run of **73** from October 1960 through last year is now available. Over 800 fiche!

You can have access to the treasures of **73** without several hundred pounds of bulky back issues. Our 24x fiche have 98 pages each and will fit in a card file on your desk.

We offer a battery operated hand held viewer for \$150, and a desk model for \$260. Libraries have these readers.

The collection of microfiche, is available as an entire set, (no partial sets) for \$325, plus \$10 shipping (USA). Annual updates available for \$10, plus \$3 shipping/handling. Satisfaction guaranteed or money back!

**BUCKMASTER**  
6196 Jefferson Highway  
Mineral, Virginia 23117 USA  
540:894-5777 • 800:282-5628  
Fax 540:894-9141  
e-mail: info@buck.com

VISA MasterCard

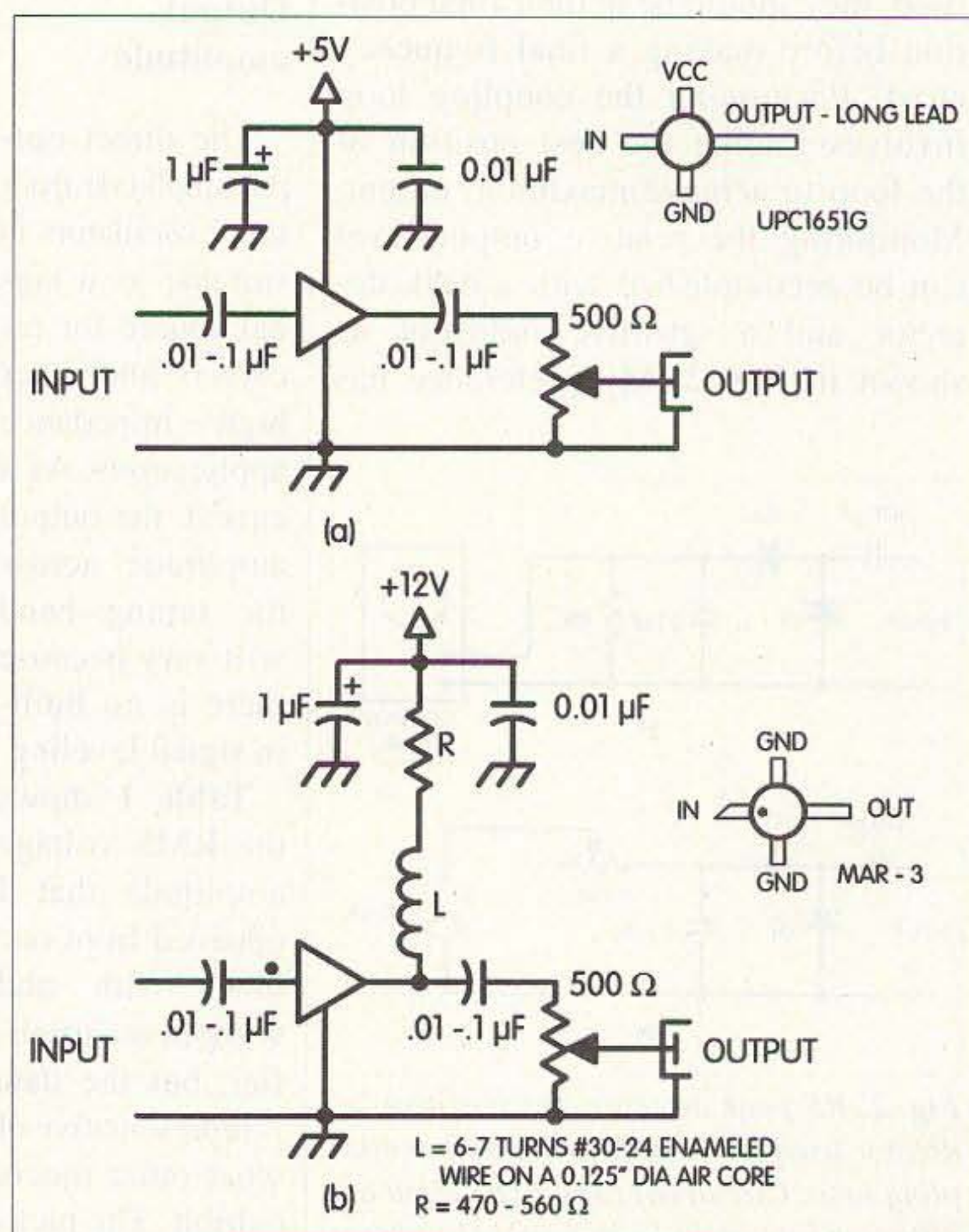

Fig. 4. Suitable output amplifiers with a 500 ohm pot used for output level control. (a) shows an NEC UPC1651G MMIC, and (b) shows the use of a Mini-Circuits MAR-3 MMIC.

# CALENDAR EVENTS

Listings are free of charge as space permits. Please send us your Calendar Event two months in advance of the issue you want it to appear in. For example, if you want it to appear in the October issue, we should receive it by July 31. Provide a clear, concise summary of the essential details about your Calendar Event.

## JULY 4

**BRESSLER, PA** The Harrisburg Radio Amateur's Club will host their 28th July 4th Firecracker Hamfest on Tuesday, July 4th, at Emerick Cibort Park in Bressler PA (near Harrisburg). The fun begins at 8 a.m. General admission \$4, XYs and harmonics admitted free. Tailgating \$5 per space. Tables \$12 each before June 1st, \$15 on or after June 1st. Setup on July 3rd, 6 p.m.–9 p.m.; setup on the 4th at 6 a.m. VE exams will be held nearby at 9 a.m. For more info call the *HRAC AnswerLine* at (717) 232-6087; E-mail [HbgRAC@excite.com], or visit the Web site at [www.members.tripod.com/hrac].

## JULY 8

**PETOSKEY, MI** The Straits Area ARC's 25th Annual Swap & Shop will be held Sat., July 8th, 8 a.m.–12 p.m., at Emmet County Fairgrounds, Petoskey MI. US 31, 2 blocks west of 131. Tickets \$4, tables \$5 (splits OK). VE exams 1 p.m. at the American Red Cross Bldg. For testing info contact *Floyd KG8CS*, (231) 526-5503. For general info contact *Tom W8IZS*, (231) 539-8459; or *Dirk KG8JK*, (231) 348-5043, E-mail [kg8jk@qsl.net].

**SALISBURY, NC** The Rowan ARS will sponsor the Salisbury Firecracker Hamfest, Sat., July 8th. From I-85, take exit 76B to Salisbury. Turn right at the ramp intersection with E. Innes St. Turn left on S. Boundary St. (Captain D's/McDonald's intersection). Go two blocks to find the Salisbury Civic Center — hamfest site on your left. Doors open at 8 a.m. Admission \$4 in advance, \$5 at the door. Indoor tables \$5 each as long as they last. Talk-in on 146.73 (W4EXU) tone 94.8; backup on 146.52 simplex. Walk-in VE exams. For more info call *Jim Morris KA4MPP*, (704) 278-4960; or *Carol Maher W4CLM*, (704) 633-6603. Send mail to *Rowan Amateur Radio Society*, P.O. Box 593, Salisbury NC 28145. E-mail [rbrown@salisbury.net].

## JULY 9

**PITTSBURGH, PA** The North Hills Amateur Radio Club's 15th Annual Hamfest will be held July 9th, 8 a.m.–3 p.m., at the Northland Public Library, 300 Cumberland Rd. Pittsburgh PA; approx. 10 miles north of

Pittsburgh on McKnight Rd. (Truck Route 19). At the 3rd traffic light after Northway Mall, turn left onto Cumberland Rd. Northland is on the left at the top of the second hill. From points north, take Route 19 south toward Pittsburgh. Follow signs for McKnight Rd., and at 4th traffic light turn right onto Cumberland Rd. If on Perry Hwy., turn left onto Cumberland Rd. at the Sunoco. Talk-in and check-ins will be on 149.09 W3EXW North Hills Club rptr. Free admission and free parking. Paved tailgating, 1st space free; additional \$5 each. Handicapped accessible. For more info contact *Keith Ostrom KB3ANK*, 205 Poplar Dr., Pittsburgh PA 15209, tel. (412) 821-4135; *Bob Ferrey, Jr. N3DOK*, tel. (412) 367-2393, E-mail [n3dok@pgh.net]; or see the club's Web site at [www.nharc.pgh.pa.us].

## JULY 15

**LOVELAND, CO** The Northern Colorado ARC will host their annual Summer Superfest from 9 a.m.–4 p.m. at the Larimer County Fairgrounds, 700 Railroad Ave. Talk-in on 145.115(-) 100 Hz PL, or 146.52 simplex. VE exams, commercial exhibits, technical sessions, computer and radio goodies, and more. Reserve tables from *Rod Cerkoney* (970) 225-0117. For general info, call (970) 352-5304.

**WELLINGTON, OH** NOARSFEST 2000 will be held at Lorain County Fairgrounds in Wellington OH. Gates open 8 a.m.–2 p.m. Check-in and directions on NOARS rptr. 146.10/.70. Dealers: Ample indoor commercial space, reservations required. Huge outdoor flea market area. Overnight parking for RV's and campers. No hookups. Indoor 8 ft. tables are \$15 each. All workers must have an admission ticket. No tickets included with tables. \$5 per 8 ft. space in flea market area. Admission \$5 each at the gate, children under 12 admitted free. Walk-in VE exams: register 8–9 a.m. Exams start at 9 a.m. NODXA DXCC card checking. Cards must be in by 11 a.m. For info, contact *John Schaaf KC8AOX*, tel. (216) 696-5709, E-mail [kc8aox@qsl.net]. Snail-mail to *NOARSfest*, P.O. Box 432, Elyria OH 44036-0432.

## JULY 16

**VALLEY FORGE, PA** The Mid-Atlantic ARC will hold their hamfest at Kimberton Fire Company Fair Grounds, Rte 113 — south of the intersection with Rte 23. Talk-in on

146.835(-) and 443.80(+). Computer and electronics hobbyists are welcome. Indoor-outdoor space: indoor tables with electricity, 1–4 for \$10 each, 5 or more, \$8 each, not including admission. Tailgating, \$5 the day of the event. Admission \$5. Contact *MARC*, P.O. Box 2154, Southeastern PA 19399; or call *Bill Owen W3KRB* at (610) 325-3995. E-mail [hamfest-info@marc-radio.org], Web site [http://www.marc-radio.org/hamfest.html].

## JULY 22

**CINCINNATI, OH** The 3rd Annual OH-KY-IN ARS Hamfest will be held at Diamond Oaks Career Development Campus, 6375 Harrison Ave., Cincinnati OH. This large facility is located just east of I-275 and I-74. Take I-74 to the Rybolt Rd./Harrison Ave. exit (exit #11). Go east on Harrison Ave. Diamond Oaks is located on the right (south side) of Harrison Ave., less than one mile from the I-74 exit. Talk-in on 146.670(-) and 146.925(-) rptrs. Admission \$4 in advance, \$5 at the door. Age 12 and under free. Features will include special seminars, transmitter hunts, and indoor vendors. Outdoor flea market spaces are free of charge (with admission) for the first two, with additional spaces at \$3 each. VE exams at 8 a.m., walk-ins accepted. Free parking. Handicapped parking available. Indoor vendor tables (6 ft. with free electric), \$8 each. Contact *Lynn Ernst WD8JAW*, 10650 Aspen Place, Union KY 41091-7665. Tel. (606) 657-6161; E-mail [wd8jaw@arrl.net]. Visit the Web site at [www.qsl.net/k8sch].

## JULY 23

**SUGAR GROVE, IL** The Fox River Radio League will hold their annual Hamfest at Waubensee Community College, Rte 47 at Harter Rd., Sugar Grove IL (5 miles NW of Aurora). Talk-in on 147.210(+), PL 103.5/107.2. Doors open Sun. at 8 a.m. Setup Sat. at 7 p.m., Sun. 6 a.m.–8 a.m. VE exams at 10 a.m., bring original license, copy of license, and photo ID. Contact *Maurice L. Schietecatte W9CEO*, c/o FRRL, P.O. Box 673, Batavia IL 60510. Tel. (815) 786-2860 or E-mail to [w9ceo@arrl.net]. The Web site is at [http://www.frll.org/hamfest.html].

## JULY 28–29

**OKLAHOMA CITY, OK** The Central Oklahoma Radio Amateurs will sponsor its 27th annual event, "Ham Holiday 2000," at the Oklahoma

State Fair Park (Hobbies, Arts & Crafts Building), northeast of the I-40 and I-44 intersection. Talk-in on 146.82. Doors open Fri., July 28th, 5 p.m.–8 p.m.; Sat. July 29th, 8 a.m.–5 p.m. Features: Technical and nontechnical programs, fox hunt, WAS card check, VE exams, and a flea market. Admission fee \$7 in advance, \$9 at the door. Flea market tables \$10 in advance, \$15 at the door, if available. Electrical hookup \$5. Additional info and registration forms available on the CORA Web site, [[www.geocities.com/heartland/7332](http://www.geocities.com/heartland/7332)]. Address other inquiries to *Ham Holiday 2000*, P.O. Box 850771, Yukon OK 73085-0771; or E-mail [[n1lpn@swbell.net](mailto:n1lpn@swbell.net)].

#### JULY 28–30

**FLAGSTAFF, AZ** The 49th Arizona State Convention and Hamfest, sponsored by the Amateur Radio Council of Arizona, will be held at Ft. Tuthill in Flagstaff AZ. Some of the features will be manufacturers, dealers, exhibits, seminars, VE exams, a huge swap, camping, and more. Gordon West WB6NOA will present two of his famous seminars, and (TBA) will be the guest speaker at the Sat. night BBQ. Other speakers, seminars and forums include Dan Miller from ARRL headquarters, Bill Pasternak from *Newsline*, AMSAT, APRS, Ten-Ten, Ladies programs, QRP, and an ARRL Forum. For more info contact *Amateur Radio Council of Arizona*, PO Box 312, 16845 N. 29th Ave., Ste. 1, Phoenix AZ 85053-3041. E-mail [[arcathill@aol.com](mailto:arcathill@aol.com)]. Voice mail (602) 779-2722. Visit the Web site at [<http://www.Hamsrus.com>].

**208-852-0830**  
<http://www.rossdist.com>

**In Stock!**

**KENWOOD**  
**UBZ-LF14Y**  
Under \$55.00

**RDC** Check Out Our Specials! We're On The Web.  
Over 9010 HAM Items in Stock. All Prices Cash FOB Preston  
ROSS DISTRIBUTING, 78 S. State Street, Preston, ID 83263  
Hours Tue.-Fri. 9-12 / 2-30-6 • 9-2 Mondays. Closed Saturday & Sunday

**FREE!**

**NEW CATALOG**

**CALL TOLL FREE: 1-800-JAN-XTAL**

**Quality Crystals and Oscillators for:**

AMATEUR BANDS • CB • MARINE VHF  
SCANNERS • MICROPROCESSORS • PAGERS

P.O. Box 60017 • Fort Myers, Florida 33906

VISA (941) 936-2397 MasterCard

**JAN Crystals**

#### AUGUST 5

**ITHACA, NY** The Tompkins County ARC will hold the Finger Lakes HAM-IN (hamfest and fly-in) at Tompkins County Airport (KITH), 3 miles NE of Ithaca. Large hangar for indoor vendors and displays. Drive-in setup. Paved outdoor flea market and parking. Airplane rides and aviation displays. Pancake breakfast and BBQ lunch served by Boy Scout Troop 80. Admission \$5, under 18 free. Indoor tables \$10. Outdoor space \$2 each. VE exams, walks welcome. Talk-in on 146.97. Contact *Richard Spingarn* (607) 387-5251.

#### AUGUST 6

**CROOKED LAKE, ANGOLA, IN** The Annual Land of Lakes ARC Hamfest will take place at Steuben County 4-H Fairgrounds, corner of 200 W and 200 N, Exit 150 off of I-69. Talk-in on 147.180 and 444.350. Packet 145.510. Tickets \$3 in advance, \$4 at the gate. Indoor tables \$8; trunk sales \$2. Vendor setup Sat. August 5th, 3–10 p.m., Sun., August 6th, 4–7 a.m. Free parking. Camping, swimming, amusement park and outlet shopping malls nearby. Contact *Bill Brown*, 905 W. Parkway Dr., Pleasant Lake IN 46779. Tel. (219) 475-5897. E-mail [[sharon.l.brown@gte.net](mailto:sharon.l.brown@gte.net)].

**MARSHFIELD, WI** The Marshfield Area ARS will hold their 10th Annual Picnic "HAMNIC" on Sun., August 6th, starting around 11 a.m. Potluck, swapfest. The location is Wildwood Park in Marshfield WI. Talk-in on 147.180. All are welcome. Contact *Guy Boucher KF9XX*, 107 West Third Street, Marshfield WI 54449. Tel. (715) 384-4323. Packet: *KF9XX @ W9IHW*. E5.AI.WI.USA.NA. E-mail [[guyboucher@tznet.com](mailto:guyboucher@tznet.com)].

#### AUGUST 20

**LEXINGTON, KY** The Central Kentucky ARRL Hamfest and Computer Show will be held at National Guard Armory, adjacent to the Lexington KY airport. From I-75 Exit 115, follow signs to the airport (KY 922 south 1.5 miles, New Circle Rd. west and south 4.6 miles, to Exit 5, Rte 60 West 1.5 mile, turn south at the traffic light. Take Man O' War south 1.3 miles, Parker's Mill west 1.2 miles, right onto Airport Rd., left onto Armory grounds. Talk-in on 146.760(-). VE exams (contact *Bob Cooper AF4OI* by August 9th, at (606) 272-6460); or E-mail [[AF4OI@cs.com](mailto:AF4OI@cs.com)]. Other features include an ARRL Forum, technical forums, commercial vendors, indoor flea market, air-conditioned building. Outdoor flea market, powerline-safety demo, aeronautical mobile demo, and special event station outside. Kentucky Horse Park, museums, and other family activities nearby. Handicapped accessible. Free parking. Free overnight self-contained camping. Admission \$5 in advance, \$6 at the gate. Vendor setup Sat., 6 p.m.–8 p.m., and Sun. 6 a.m.–8 a.m. Tables \$15 if payment received before August 9th; \$25

afterwards. E-mail/phone reservations confirmed upon receipt of payment. Tailgating free with admission. For further info, or to preregister, contact *John Barnes KS4GL* at [[KS4GL@juno.com](mailto:KS4GL@juno.com)], (606) 253-1178 evenings; or *SASE John Barnes KS4GL*, 216 Hillsboro Ave., Lexington KY 40511-2105.

#### SPECIAL EVENTS, ETC.

#### JULY 1–2

**DeSMET, SD** The Lake Area Radio Klub/Huron ARC W0WTN will be on the air from 1700Z July 1st to 2200Z July 2nd, to commemorate Laura Ingalls Wilder, author of *Little House on the Prairie*. Frequencies: 7.265, 14.265, 28.465, 50.165. A certificate will be available. Write to *LARK*, Box 642, Watertown SD 57201-0642.

#### JULY 23

**STRATFORD, NY** The Fulton County Dr. Mahlon Loomis Committee will operate W2ZZJ on July 23rd, to commemorate the 174th anniversary of the birth of Dr. Loomis, the American radio pioneer. Loomis was born at Oppenheim NY on July 21st, 1826. Operation will be from 1300–2000 UTC on the General class phone portion of 75, 40, and 20 meters, and on the Novice 10 meter phone band; also, on area 2-meter FM repeaters. For a certificate and extensive literature, send QSL, contact number, and a #10 SASE (55 cents) to *George P. Sadlon W2ZZJ*, 5738 STHWY 29A, Stratford NY 13470. Visit the Dr. Mahlon Loomis Web site at [<http://members.xoom.com/mahlon/>].

#### AUGUST 19–20

**ENGLEWOOD, NJ** The Englewood (NJ) ARA, Inc., invites all amateurs the world over to take part in the 41st Annual New Jersey QSO Party. The time of the contest is from 2000 UTC Sat., August 19th–0700 UTC Sun., August 20th; and from 1300 UTC Sun., August 20th–0200 UTC Mon., August 21st. Phone and CW are considered the same contest. A station may be contacted once on each band — phone and CW are considered separate bands. CW contacts may not be made in phone band segments. New Jersey stations may work other New Jersey stations. The General call is "CQ New Jersey" or "CQ NJ". New Jersey stations are requested to identify themselves by signing "DE NJ" on CW and "New Jersey calling" on phone. Suggested frequencies are 1810, 3535, 3950, 7035, 7235, 14035, 21100, 21355, 28100, 28400, 50-50.5, and 144-146. Suggest phone activity on the even hours, 15/10 meters on the odd hours (1500 to 2100 UTC); 160 meters at 0500 UTC. For complete rules, please contact *Englewood Amateur Radio Assn., Inc.*, P.O. Box 528, Englewood NJ 07631-0528.

Bill Pasternak WA6ITF  
Broadcasting and Teleproduction  
28197 Robin Avenue  
Santa Clarita CA 91350  
[billwa6itf@aol.com]

# The Rocky Road to a Great Radio Club

*An interview with Jeff Seligman WA2VNT/7.*

*A long, long time ago, in a city far, far away, I spent my latter teenage years on a band called 6 meters, using a mode called full carrier Amplitude Modulation. It was the late '50s and early 1960s. The place was the "free and independent nation of Brooklyn, New York," and every ham strove to have the best-sounding audio on the airwaves.*

**B**ack then, it was easy to tell the wheat from the chaff — those who built their transmitters from those who bought them — by the audio characteristics. Within a few weeks a newcomer could tell a Gonset Communicator from a Viking Challenger or a Lettine 242. Every radio had its own peculiar "sound" and those who wanted to stand out from the rest usually rolled their own.

From the time I was first licensed until I bought my first transceiver (a National NCX-3 and P+H Transverter to 6 meters), I built at least two dozen 6 meter AM transmitters. Some were attempts to improve the "sound" of my signal. Others, like the famed "Hairy-Modulated 6146" were more for fun. Fun as in "Well, OM, you have plenty of audio, but it sounds — well — kind of hairy!"

During my rather abbreviated student career at the New York City Community College of Applied Arts and Sciences (then recently opened in the abandoned Brooklyn Pickle Works building), one of the assignments was to build and demonstrate a working amplitude modulated transmitter. There was no restriction on frequency, although

the instructors cautioned to try to keep the output power under 150 milliwatts and the signal contained in the broadcast band. As a result, many students came up with nothing more than the then-popular single tube "phonograph oscillator" transmitters — but built on a chassis that could have housed a half gallon on any band.

I would have none of that! With lots of transmitters under my belt, a ham radio callsign of WA2HVK, and access to both the college metal shop and WA2INM's seemingly unlimited supply of "used but good" parts, I set out to build something a lot more utilitarian. I was going to fit at least 20 watts of good 50 MHz RF and high level processed plate modulation into a box that was about 7" high, 10" long and 6" deep! It would operate on 6 meters; it would be fully metered; it would have the audio quality close to the then popular WABC "Musicradio"; and it would be a transmitter that the school would long remember.

We were given two or three weeks to complete our transmitters. Cramming all that "good stuff" into such a tiny box — complete with power supply — took all of it. In the end, it delivered

what was expected of it and more. Using a Techcraft CC-50 converter and Lafayette HE-10 receiver tied to one dipole to receive and this miniature (for its time) transmitter tied to another dipole — both hung inside the classroom — I hit the transmit switch and uttered forth the words: "This is



*Photo A. The author (left) was a guest at last October's hamfest in Tucson. Photos courtesy WA6ITF.*

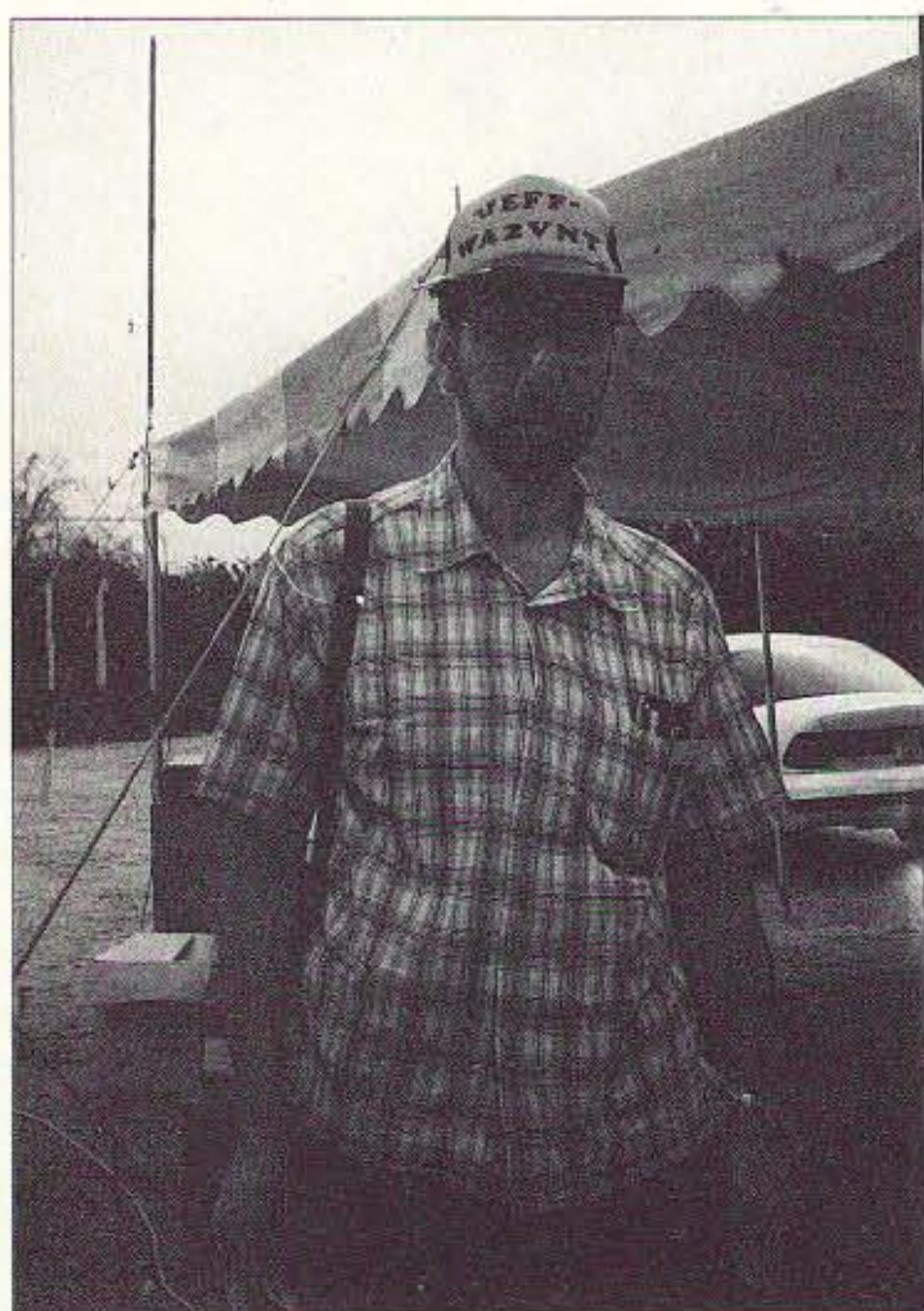

Photo B. Jeff Seligman WA2VNT/7.

WA2HVK portable 2 testing. Testing 1-2-3-4-5. Hello, test. This is WA2HVK testing and clear!"

I have no idea if the school "long remembered" my transmitter, but that class sure was impressed. The RF section was nothing special. Just a 2E26 with 350 volts on its plate fed by a 6AW8 oscillator/multiplier. But the audio section was something else again. A 12AX7/ECC83 was the preamp, a 6C4 served as processor/limiter. Its output went to a 12AU7 split-load phase inverter that fed a pair of type 6AQ5A beam power pentodes (Class AB1) and produced a clean 12 watts of audio. That was more than enough to fully modulate the 20 watt RF section. The positive impression came from the people around the city of New York and northern New Jersey who one after another called to tell me how good the "rig" sounded. Musicradio it wasn't, but an A+ it got me.

What does a ham do with a new transmitter that gains him immediate complaints on its audio? He replaces his old one with it. And that's exactly what I did. Throughout 1961, that transmitter was my own "sound" that set me away from the crowd.

Like all hams of the day, I was always wanting something better. I figured that if I could cram 20 watts into a 10" wide cabinet I should be able to cram 60 watts into a 3" x 5" x 7" BUD

chassis box. To pay for the new "rig" I put the old one up for sale. It was purchased by a teenage ham from Flatbush, Brooklyn, named Jeff WA2VNT.

Well, the 60 watts in a tiny box was a disaster. I won't go into all the details. Suffice to say that in the days of tube-type amplifiers, there were some laws of physics that could not be broken. And when you tried to circumvent them, disaster was right around the corner. Or as WA2INM was often heard to say: "... some ideas work, and others smoke resistors."

In the middle '60s, I moved over to SSB and lost contact with my old AM friends. It would be several decades before Jeff and I would again cross paths. That happened when he also moved to California in the late '80s. In the early 1990s, he once again relocated to Tucson, Arizona, and this is where our story really begins.

You see, Jeff's introduction to ham radio clubs in Tucson was far from auspicious. In fact, it was a real downer to him, after being a part of one of the West Coast's most vital ham radio organizations. But let's let him tell the story.

### The Interview

**WA6ITF:** You came to Arizona from California, where you were involved with several radio organizations. What did you find in Tucson?

**WA2VNT/7:** I came to Arizona in December 1992 and started attending radio club meetings in 1993. As it came closer to Field Day, I saw there was a lot of factioning in the clubs as to how Field Day would be dealt with, how the new hams would be integrated in. And in this case they were not invited as they [the clubs] wanted to have the best operators. The net result was that a lot of the newer hams felt totally left out.

After Field Day, I talked with a number of hams and assessed the situation. And I found that what was happening was that there were so many different technologies involved with communications, that it was very difficult for any one club to have all members holding the same interest at any one time.

Here in Tucson, they also have a very large computer club called the Tucson Computer Society. I went to one of its meetings and learned that they had found a way to get around the problem by organizing "Special Interest Groups" — or SIGs — that meet outside of the regular club meeting time and at a different location. Further, each SIG has members whose interest deal with a specific issue. When the members of these SIGs come to the regular club meeting they each are given time to present a report. Also, each SIG has its own column in the club newsletter, where the SIG leader summarizes what's happening within that group. This allows the general membership at a meeting to discuss the various SIGs and decide which ones each wants to be active in. And that's when I realized it was time to form a new radio club here in Tucson. The "Radio Society of Tucson."

**WA6ITF:** A new radio club? Why form a new one?

**WA2VNT/7:** I formed the club because there was no club that dealt with the interests of newer radio amateurs, including amateurs with computer interests and packet radio interest.

What Tucson had was TAPR (Tucson Amateur Packet Radio, Inc.). It had another club that dealt primarily with contests — primarily on HF. Then they had another club at the University of Arizona and yet another that dealt with repeaters and emergency communications. There is also a separate DX group.

What I saw was heavy fractionation. Each ham would be interested in only one thing and not another. But what I also saw was an alienation of the newer hams.

**WA6ITF:** Describe what you mean by alienation.

**WA2VNT/7:** Well, some of the newer hams wanted to know what Field Day was about. All that the club wanted to do was to set up a team of five hams to strictly operate HF CW, and they did not want any inexperienced radio amateurs at the Field Day.

I felt slighted. I had come from California and the club that I had belonged



to — the Conejo Valley ARC — held the record for winning the greatest number of consecutive Field Days, the largest number of Field Days over a ten year period, and I think that they have also beat the highest all-time score under Steve Katz WB2WIK. There was even a video made about the CVARC Field Day that anyone can buy. And, even though CVARC didn't have SIGs, they did have committees. As a result, CVARC was able to place a fine focus on anything.

I tried to point out that the new operators are primarily interested in digital-based communications as well as more traditional forms. Also, that many newcomers are only on VHF and UHF and may not know much about the Morse code but that they are willing to learn. But to organize a Field Day as a contest the way in which this one club did was not right — it is primarily a demonstration of emergency preparedness. Also, that scoring in Field Day is maximized for the greatest number of members in a club participating and operating the most number of stations. In other words, simulating the worst possible emergency situation yields the highest score. CVARC has proven this in Southern California — year after year after year.

**WA6ITF:** So what you are saying is that there was this total fractionalization.

**WA2VNT/7:** In Tucson, the older operators could not seem to understand the needs of the newer operators and vice versa. So I tried to explain to the older operators that what they were doing would be great in a contest, that in Field Day it would not give them a winning score regardless of the number of contacts made. Also, that their plan circumvents the primary purpose of Field Day, which is to introduce the community to the newer hams as well as show these new operators how to operate properly under emergency conditions.

After I spoke, a number of hams approached me who were interested in doing a different kind of a Field Day operation. They wanted to know how to organize it. As a result, over the

## Ham Mall

The world's largest internet store dedicated to Ham Radio!

[www.HamMall.com](http://www.HamMall.com)

This is the internet store that has it all! Open 7 days per week - 24 hours per day. Browse through our catalog viewing pictures, descriptions, accessories, and our low prices. If you are looking for a hard to find item, Email us at [Bill@HamMall.com](mailto:Bill@HamMall.com), and we will try to locate it for you.

### Check out all we offer!

Call Wall QSL Manager Listing News, Announcements and Specials  
Ham-to-Ham Discussion Groups Ham Shack Photos

Visa/MasterCard accepted on line. Free shipping in continental US on all orders over \$100.

When in Seattle visit us at:

Radio Depot, Suite 176, 5963 Corson Ave., So. Seattle, WA 98108

Phone (206) 763-2936 Fax (206) 763-4172

### Amplifiers, ATU Down Converters & Hard to Find Parts

<p style="text-align: center;"><b>LINEAR AMPLIFIERS</b></p> <p><b>HF Amplifiers</b> PC board and complete parts list for HF amplifiers described in the Motorola Application Notes and Engineering Bulletins:</p> <table style="width: 100%;"> <tr> <td>AN779H (20W)</td> <td>AN 758 (300W)</td> </tr> <tr> <td>AN779L (20W)</td> <td>AR313 (300W)</td> </tr> <tr> <td>AN 762 (140W)</td> <td>EB27A (300W)</td> </tr> <tr> <td>EB63 (140W)</td> <td>EB104 (600W)</td> </tr> <tr> <td>AR305 (300W)</td> <td>AR347 (1000W)</td> </tr> </table>	AN779H (20W)	AN 758 (300W)	AN779L (20W)	AR313 (300W)	AN 762 (140W)	EB27A (300W)	EB63 (140W)	EB104 (600W)	AR305 (300W)	AR347 (1000W)	<p><b>2 Meter Amplifiers</b> (144-148 MHz) (Kit or Wired and Tested)</p> <p>35W - Model 335A, \$79.95/\$109.95 75W - Model 875A, \$119.95/\$159.95</p>	<p style="text-align: center;"><b>HARD TO FIND PARTS</b></p> <ul style="list-style-type: none"> <li>• RF Power Transistors</li> <li>• Broadband HF Transformers</li> <li>• Chip Caps - Kemet/ATC</li> <li>• Metalclad Mica Caps - Unelco/Semco</li> <li>• ARCO/SPRAGUE Trimmer Capacitors</li> </ul> <p>We can get you virtually any RF transistor! Call us for "strange" hard to find parts!</p> <p style="text-align: center;"><b>DIGITAL FREQUENCY READOUT</b> For older analog transceivers TK-1 (Wired and Tested) \$149.95</p>
AN779H (20W)	AN 758 (300W)											
AN779L (20W)	AR313 (300W)											
AN 762 (140W)	EB27A (300W)											
EB63 (140W)	EB104 (600W)											
AR305 (300W)	AR347 (1000W)											

**ATU Down Converters**  
(Kit or Wired and Tested)

Model ATV-3 (420-450)  
(Ga AS - FET) \$49.95/\$69.95

Model ATV-4 (902-926)  
(GaAS - FET) \$59.95/\$79.95

**ADDITIONAL ITEMS**

Heat Sink Material  
Model 99 Heat Sink (6.5" x 12" x 1.6"), \$24  
CHS-8 Copper Spreader (8" x 6" x 3/8"), \$24  
Low Pass Filters (up to 300W) for harmonics \$12.95  
Specify 10M, 15M, 20M, 40M, 80M or 160M  
HF Splitters and Combiners up to 2KW

For detailed information and prices, call or write for our free catalog!

**Phone**  
(937) 426-8600  
**FAX**  
(937) 429-3811

508 Millstone Drive • Beavercreek, Ohio 45434-5840  
e-mail: [cci.dayton@pobox.com](mailto:cci.dayton@pobox.com)  
[www.communication-concepts.com](http://www.communication-concepts.com)

<ul style="list-style-type: none"> <li>• DIP switch programmable</li> <li>• Miniature in size</li> <li>• 37 EIA tones, 27 non-standard tones from 33.0 to 254.1 Hz included</li> <li>• Reverse Burst built-in</li> <li>• Easy 3 wire hookup</li> </ul> <p style="text-align: center; font-size: x-small;">SS-64 CTCSS Encoder .66" x 1.08" x .21"</p>	<p style="text-align: center;"><b>SS-64 DIP Switch Programmable CTCSS Encoder \$28.95</b></p>	<ul style="list-style-type: none"> <li>• Fully enclosed CTCSS encoder</li> <li>• All 32 EIA tones from 67.0 to 203.5 Hz included</li> <li>• Perfect for mobile / base applications</li> </ul> <p style="text-align: center; font-size: x-small;">TE-32 5.25" x 3.3" x 1.7"</p>	<p style="text-align: center;"><b>TE-32 Multi-Tone CTCSS Encoder \$49.95</b></p>						
<p style="text-align: center; font-size: x-small;">TP-3200 Shared Repeater Tone Panel</p> <table style="width: 100%; font-size: x-small;"> <tr> <td>TP-3200D Table Top Version</td> <td style="text-align: right;">\$269.95 each</td> </tr> <tr> <td>TP-3200RM-A Single Rack Mount version</td> <td style="text-align: right;">\$279.95 each</td> </tr> <tr> <td>TP-3200RM-B Triple Rack Mount version</td> <td style="text-align: right;">\$279.95 each</td> </tr> </table> <p style="font-size: x-small;">*Holds up to three TP-3200s</p>	TP-3200D Table Top Version	\$269.95 each	TP-3200RM-A Single Rack Mount version	\$279.95 each	TP-3200RM-B Triple Rack Mount version	\$279.95 each	<ul style="list-style-type: none"> <li>• 51 CTCSS Tones</li> <li>• 106 DCS Codes</li> <li>• Supports 157 Repeater Subscribers</li> <li>• On-Line Computer Help</li> <li>• Repeater CW ID</li> <li>• Air Time Loading &amp; Analysis Graphs</li> <li>• Signalling Formats: CTCSS DCS &amp; DTMF</li> </ul>	<p style="text-align: center; font-size: x-small;">ID-8 Automatic Morse Code Identifier 1.85" x 1.12" x .35"</p>	<p style="text-align: center; font-size: x-small;">ID-8 Automatic Morse Station Identifier \$69.95</p>
TP-3200D Table Top Version	\$269.95 each								
TP-3200RM-A Single Rack Mount version	\$279.95 each								
TP-3200RM-B Triple Rack Mount version	\$279.95 each								

Call or write to receive our full Product Catalog or visit our Web site for complete information at:  
<http://www.com-spec.com>

426 WEST TAFT AVENUE • ORANGE, CA 92665-4296  
(714) 998-3021 • FAX (714) 974-3420  
Entire U.S.A. (800) 854-0547 • FAX (800) 850-0547  
<http://www.com-spec.com>

summer of 1993 I formulated plans for a new type of amateur radio club based on the computer club model of Special Interest Groups, so that each area of amateur radio and the needs of each community within the amateur radio structure could be represented. In the fall of 1993, I organized a meeting where I proposed this new kind of club based on SIGs that could become a thriving entity that would have a constantly renewing aspect to it. It would never become obsolete or outdated, because anytime it needed a new interest it could form another Special Interest Group.

As it stands now, this club has a SIG for CW, another for packet, another for APRS, yet another for repeaters, and numerous other specialties.

**WA6ITF:** So, what you are saying is that if someone invented whoop-de-doo modulation, there might be some club interest in it?

**WA2VNT/7:** Exactly. And we would go to the club's general membership and tell them that we need some money for this new SIG and maybe you can raise some through donations of equipment or whatever. And the club does it — or — in other words — the purpose of the club is really to meet the needs of its SIGs and for the SIGs to provide something back to the club. It's reciprocal.

By way of example, we have a Special Events Coordinator and under him a station operating at the Pima Air Museum. A first! And that area of special interest — we call it Community Awareness — is just one of many.

**WA6ITF:** So you are saying that your club is doing things to involve the world outside ham radio with the club?

**WA2VNT/7:** Let's just say that will permit community awareness of amateur radio and what we are doing. We are not as far along as CVARC, but at the same time we are doing things that CVARC did not do. These SIGs are at national sites and call attention to ham radio on a national basis.

The Pima Air Museum ham radio operation is an excellent example. The museum is a wonderful resource that lets people know the kind of sacrifices that were made during World War 2 as

well as shows all of the aircraft and explains the conditions under which people had to fight that war.

**WA6ITF:** OK. A hypothetical situation here. You find yourself back home in Brooklyn New York. It's a city with little ham radio cohesiveness. How would you apply the concept there?

**WA2VNT/7:** I would think that in a large city, that this would be even more successful than in a smaller city. In a large city, you have very varied interests, along with a large number of amateur radio operators bringing in a diverse cross-section of culture — especially in New York City, which is culturally diverse to begin with.

New York City is really a prime target for an organizational structure like this. For instance, you could have a SIG group for Emergency Communications — and as I remember, Brooklyn had a very active ARES and RACES. It's really a case of using your imagination as the needs arise.

**WA6ITF:** Relate this to kids. Carole Perry WB2MGP, who produces the Youth Forum for the Dayton Hamvention, tells me she is having problems getting young hams as speakers.

**WA2VNT/7:** Young kids nowadays are very computer-oriented. To have a club where all that is talked about is HF CW DXing is of no appeal to younger kids. This is a worldwide ham radio problem that is — ironically — better addressed on the Internet.

Our partial solution is an "Internet Gateway" that is not only tied to a packet station but also serves as a conversation link. Through that gateway you can converse with amateur radio operators worldwide who are also on the Internet, or you can choose to bring up the packet system and connect to other packet people. It's such a clean switch that when you are on packet you cannot tell if a station coming in from — say, Russia — if it's calling in on packet or via the Internet. There is no distinction — it is fully integrated. This crosses that barrier between the Internet and amateur radio.

**WA6ITF:** Then you see a kind of

synergy between ham radio and the Internet?

**WA2VNT/7:** We were very quick to recognize the power of the Internet and how useful it could be. As a result, we were the first club in Tucson with a home page on the Web. We have had it there since the club began, courtesy of AA7VX, who is an ISP.

We also have an AX-25 "ham gate" for which I hold the STA and operate with WB7TLS. It's a joint station that we have been running and anyone can get on, access WB7TLS, and message through the system to the Internet. And, lest I forget, we also have a Tucson-wide packet network on the air as well.

**WA6ITF:** You also have something in Arizona not found in many other places, that being a statewide organization.

**WA2VNT/7:** That's true. We have ARCA — the Arizona Council of Amateur Radio Clubs. Its existence makes it a lot easier for statewide issues to be resolved.

**WA6ITF:** All of this is great, but is it self-perpetuating? If Jeff WA2VNT/7 decides to move to Milwaukee, what happens to ham radio in Tucson?

**WA2VNT/7:** In one sentence: I know that the Radio Society of Tucson will survive. This is because its structure has that self-renewing feature I told you about earlier on. It will always renew itself because of its structure based on Special Interest Groups. At least I hope it will.

## Epilogue

By now, there has to be at least one question on every thinking ham's mind: "Can SIGs save my club from the oblivion it seems headed toward?"

I'll keep the answer to this one very short. It worked in Tucson, but you will never know if it's the answer to your needs unless you give it a try.

## Resources

Bill Pasternak WA6ITF can be contacted by E-mail at: [billwa6itf@aol.com].

Jeff Seligman WA2VNT can be

*Continued on page 58*

Mobile, get there with

COMET!

**EW MH-209SMA** • Dual-band 146/446MHz HT Antenna w/SMA Conn  
Gain & Wave: 0 1/4 wave • Length: 3" Flexible rubber • Conn: Male SMA • Max Pwr: 5W

**EW SMA-503** • Dual-band 146/446MHz HT Antenna w/SMA Conn  
Length: 8.75" • Conn: Male SMA • Max Pwr: 10W

**EW MH-510** • Tri-band 52/146/446MHz HT Antenna w/SMA Conn  
Length: 20.75" • Conn: Male SMA • Max Pwr: 10W

**SB-15** • Tri-band 52/146/446MHz w/fold-over  
Gain & Wave: 52MHz 0dBi 1/4 wave • 146MHz 4.5 dBi 6/8 wave • 446MHz 7.2dBi 5/8 wave x 3 • Length: 58" • Conn: PL-259 • Max Pwr: 120W

**SBB-7 SBB-7NMO** • Dual-band 146/446MHz w/fold-over  
Gain & Wave: 146MHz 4.5dBi 6/8 wave • 446MHz 7.2dBi 5/8 wave x 3 • Length: 58" • Conn: SBB-7 PL-259/SBB-7NMO NMO • Max Pwr: 70W

NEW BLACK COLOR

**SBB-5 SBB-5NMO** • Dual-band 146/446MHz w/fold-over  
Gain & Wave: 146MHz 2.5dBi 1/2 wave • 446MHz 5.5dBi 5/8 wave x 2 • Length: 39" • Conn: SBB-5 PL-259/SBB-5NMO NMO • Max Pwr: 120W

NEW BLACK COLOR

**Z750** • Dual-band 146/446MHz w/fold-over • Includes COMET exclusive theft-resistant lock!  
Gain & Wave: 146MHz 2.15dBi 1/2 wave • 446MHz 5.5dBi 5/8 wave x 2 • Length: 39" • Conn: Gold-plated PL-259 • Max Pwr: 200W

**Z780** • Dual-band 146/446MHz w/fold-over • Includes COMET exclusive theft-resistant lock!  
Gain & Wave: 146MHz 6/8 wave 4.5dBi • 446MHz 5/8 wave x 3 7.2dBi • Length: 62" • Conn: Gold-plated PL-259 • Max Pwr: 150W

**B-20 B-20NMO** • Dual-band 146/446MHz w/fold-over  
Gain & Wave: 146MHz 2.15dBi 1/2 wave • 446MHz 5.0dBi 5/8 wave x 2 • Length: 30" • Conn: B-20 PL-259/B-20NMO NMO • Max Pwr: 50W

**B-10 B-10NMO** • Dual-band 146/446MHz cellular look-a-like •  
Gain & Wave: 146MHz 0dBi 1/4 wave • 446MHz 2.15dBi 1/2 wave • Length: 12" • Conn: B-10 PL-259/B-10NMO NMO • Max Pwr: 50W

• The CA-UHV is a 6M/2M/70cm triband antenna. Add 2-3 of the stock or optional coils for 5-6 band operation.  
• HF-70cm all in one economical easy to mount antenna.  
• Fold-over hinge built in.  
• Select the correct duplexer or triplexer for your specific radio (s).  
• CF-706A, CF-530, CFX-514N (Ask your dealer)

**NEW CA-UHV** • HF/6M/2M/70cm Mobile Antenna40/\*20/\*17/15/10/6/2M/70cm **40M Thru 70cm!**  
Gain & Wave: HF-6M 1/4 wave • 2M 3.4dBi 5/8 wave • 70cm 2.15dBi 1/2 wave • VSWR: HF 1.6:1 or less • 6M-70cm 1.5:1 or less • Length: 6'2"  
Max Pwr: HF 120W SSB • 6M 200W SSB/100W FM • 2M/70cm 100W FM • \*L-14 Optional 20M coil • \*L-18 Optional 17M coil

**NEW MSG-1000C** • Dual-band 146/446MHz w/spring whip and fold-over  
Gain & Wave: 146MHz 2.15dBi 1/2 wave • 446MHz 5.5dBi 5/8 wave x 2 • Length: 39" • Conn: PL-259 • Max Pwr: 120W

**NEW MSG-1100C** • Dual-band 146/446MHz w/spring whip and fold-over  
Gain & Wave: 146MHz 3.5dBi 1/2 wave • 446MHz 6.0dBi 5/8 wave x 2 • Length: 43" • Conn: PL-259 • Max Pwr: 150W

NEW MSG SERIES\*

Performance and Durability!  
Designed with a spring in the whip to absorb impacts.

For a complete catalog of NCG/COMET Antenna products call or visit your local dealer. Or contact NCG Company at **800/962-2611**. Use NCG/COMET products, and enjoy amateur radio to it's fullest!



**COMET**™  
\*NCG Product  
1275 N. Grove Street • Anaheim • California 92806  
(714) 630-4541 • (800) 962-2611  
Fax: (714) 630-7024 • www.cometantenna.com



# When They Say Multiband, They Mean It!

*73 reviews the Comet CA-UHV antenna.*

*Have you put off running HF mobile because you don't want a large, ungainly antenna interfering with the aerodynamic shape of your new car? Maybe you haven't added HF because the XYL is only willing to tolerate one ham antenna per vehicle. Maybe you drive a company car and they have rules prohibiting permanent or significant changes to their vehicles. If so, you just ran out of excuses. Here is an antenna that is easy to install, presents an unobtrusive silhouette, covers multiple bands, and most importantly, provides performance!*

Comet Antennas has long offered exceptional antenna products for amateur radio use. I have used one of their QE-14 models for twenty meters for better than two years, with excellent results. Many a long trip has been made much more enjoyable by having the ability to ragchew with another stateside station or work a little DX. I've been accused of being one of those real radio nuts who feels that a car looks naked without an array of antennas.

Actually, although I appreciate the appearance of an antenna, I'm far more interested in what it can do. My normal complement usually includes a 2m/70cm antenna for local communications and the 20m Comet, and at times I also add a 10m antenna to work the FM repeaters.

Needless to say, I take a fair amount of teasing about my car looking like a frustrated porcupine (or worse) from friends who do not appreciate the finer things in life. Recently, my trusty old UHV/VHF antenna gave up the ghost after seven years of use. Some would feel that this would provide an excuse to replace the existing antenna with a similar type. Au contraire! Part of the enjoyment of our hobby is the quest

for the new and exciting, so I seized the opportunity and began to look at what options might prove interesting.

### **The ideal mobile antenna?**

What features would the ideal mobile antenna have? It should be easy to mount to the car without drilling holes through the car body — particularly through a portion of the body which shows, such as the roof or a fender. It should be large enough to perform effectively but not so large as to be unwieldy. It should cover the bands I frequently use, with a minimum of fuss when changing bands.

Okay, that's a lot to ask, and I assumed that I would have to use a minimum of two antennas to permit me to operate APRS on the VHF bands even when I'm working HF. Imagine my pleasant surprise when I found that there was a single antenna which could meet ALL my needs! I can now operate on the bands I normally use with only one antenna which can be easily installed, easily stowed, and just as easily removed.

The Comet Model CA-UHV is the antenna I needed, and it presented one pleasant surprise after another. About

the only thing predictable about it was the fact that it is vertically polarized.

Let's start at the bottom and work our way up. The CA-UHV has a PL-259 mount, which seems to be the most popular style of antenna mount in use today. This mount also lends itself to special applications and experimentation. There are many UHF and VHF antennas with PL-259, but there aren't as many HF radiators. This means that there are many antenna mounts available which provide the matching SO-239 mount. Some of these are fairly heavy-duty and can be adjusted to ensure that the antenna is correctly oriented, which makes the Comet antenna a likely candidate to occupy that place of honor on your vehicle.

There are SO-239 mounts which can be installed on the trunk lip of most cars, and for larger vehicles there are luggage rack mounts and mirror mounts which will work equally well. For people with antenna restrictions for the home station, Field Day or emergency operations, the PL-259 mount means that you could design a fixed mount for this antenna without requiring a machine shop in the garage. With a little experimentation, this Comet antenna just might end up doing double duty!

For mobile use, I prefer a trunk lip mount, which is easy to attach and works well for my car. Don't forget that in most cases it will work better if the antenna is on the driver's side of the car, since tree branches tend to be lower the closer you get to the curb. If you do choose a trunk lip mount, make sure that you position the mount far enough back so that you can open the trunk without hitting the rear window of the car. Securely fasten the set screws on the mount to provide both mechanical integrity and an electrical connection.

I use cable ties to secure the coax to the trunk lid and a point near the hinge. Then, after passing it under the back seat, I merely route it under the door trim until I get to the front of the car. If your radio is floor-mounted, you may just bring it under the car seat and then under the carpet to a small hole. For an in- or under-dash-mounted rig, you can continue the coax run under the plastic panels until it can be secured under the dashboard.

### Configuring the Comet CA-UHV

After routing the coax to the operating position, it then is time to determine exactly how you wish to configure your Comet CA-UHV. The antenna comes packaged with the main mast and a selection of resonators. By selecting the correct resonators, this antenna can easily be configured to run three, four, or five bands, and can operate on even more under special circumstances. If you have a radio which includes HF through two or six meters, you will soon realize why this antenna is just about perfect for you.

This antenna needs no special configuration and probably will not need any tuning for six meters or higher. In most cases, it only requires that you plug the coax into the radio and screw the antenna onto the mount. Most of us have the urge to check and recheck the SWR just to see how close to that perfect match of unity we can get. This precision has more to do with bragging rights on the air than any functional purpose, but it is important nevertheless.

Hook up your handy SWR meter between the transceiver and the radio and



*Photo A. Before — Here's my car with a twenty-meter antenna on the trunk lid, two-meter/seventy-centimeter glass mount antenna and ten-meter magnetic mount on the roof. I've been accused of having a car that looks like a porcupine.*

see how it looks. Personally, I find 1.5:1 to be more than acceptable, and when I tried this antenna, it was well below this for throughout both the 2m and 70cm bands. If you want to fine tune the antenna for 6m or 2m operation, a set screw at the base of the antenna can be loosened and modest adjustments made to the length of the

mast. For 440 MHz, there is a tube called a "choke pipe" on the lower section of the mast which can be raised or lowered to adjust the tuning. The choke pipe has a waterproof cap at the top which should be moved first to make the adjustment easier. If you choose to adjust the antenna for these frequencies, you should be able to

## EZ HANG KIT™

**WILL SHOOT A LINE OVER A 100 FOOT TREE WITH EASE**

HANG YOUR NEXT WIRE ANTENNA

THE EZ HANG WAY

BETTER THAN A BOW & ARROW

PUT THAT NEXT DIPOLE WHERE YOU WANT IT !!!

IN HALF TIME WITH THE EZ HANG

AND THE EZ WINDER OUR INTERMEDIATE LINE

WITH DISPENSER 500' OF 155 LB TEST

STAKEABLE HANDLE

CRANK TWIST OFF TOP



### EZ HANG KIT



**EZ HANG KIT**

1 EZ HANG

1 PACK OF 5 WEIGHTS

1 EZ WINDER

SHIPPING

TOTAL COST \$69.80

SAVES YOU \$9.95 ON THIS KIT PACKAGE

MD RESIDENTS ADD

5% SALES TAX

**MAKE YOUR NEXT  
ANTENNA HANGING  
EXPERIENCE A PLEASANT**

### EZ HANG



[WWW.EZHANG.COM](http://WWW.EZHANG.COM)

E-MAIL US AT:

[EZHANG@EZHANG.COM](mailto:EZHANG@EZHANG.COM)

(540) 286-0176

SEND CHECK / MONEY ORDER

EZ HANG INC.

8645 TOWER DRIVE

LAUREL, MD. 20723

\$49.95 EZ HANG

\$5.95 SHIPPING

PATENT PENDING

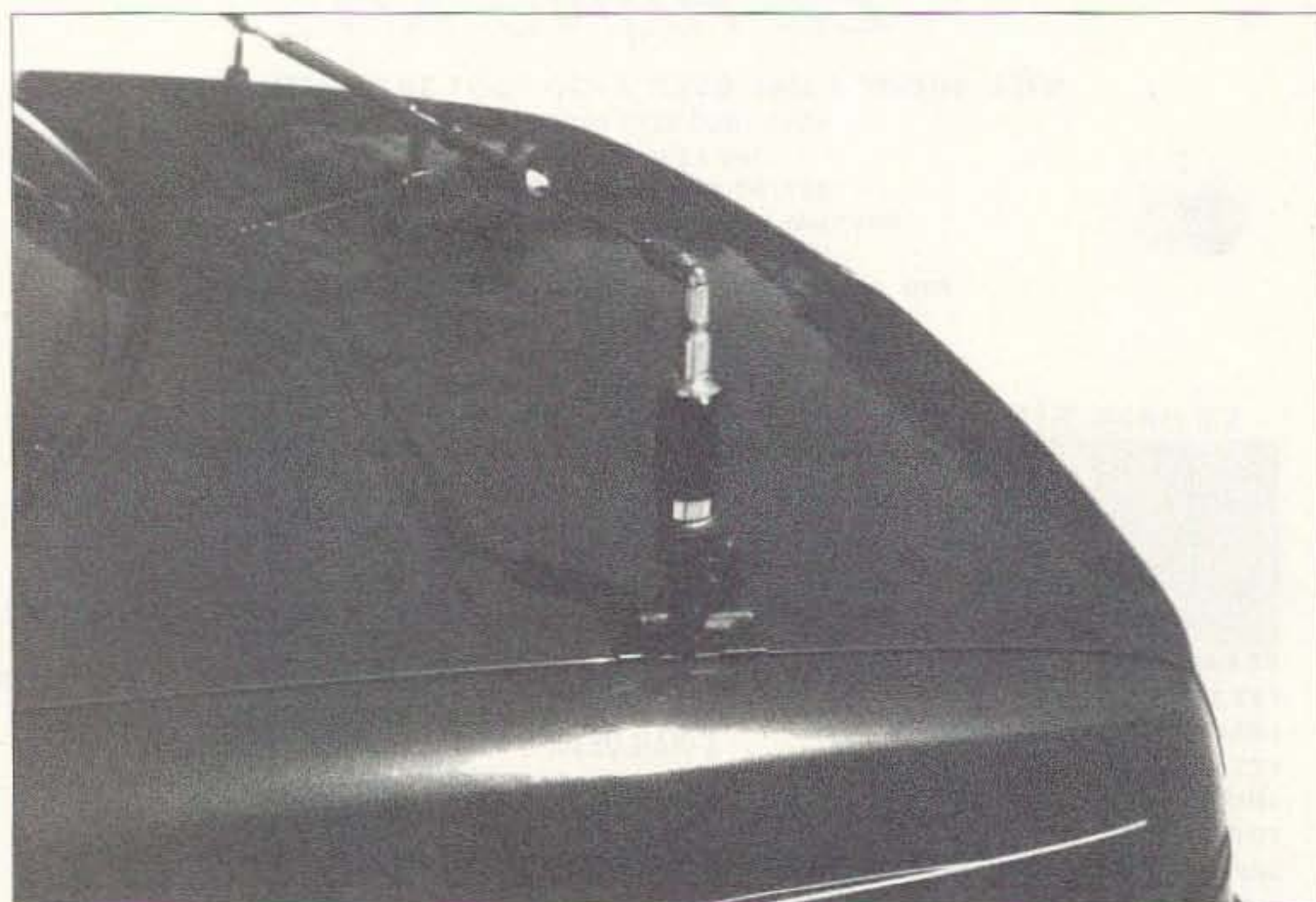

*Photo B. After — With the Comet CA-UHV antenna on the trunk lip mount, I've kept all of the capabilities that used to require three antennas. Plus, I can swap out resonators to add other HF bands as my needs and band conditions change.*

achieve close to a 1:1 ratio at your center frequency and less than 1.5:1 for 2m and 440 MHz. About 75% of the 6m band should be less than 1.5:1, with the remainder only slightly higher.

But wait! Was I looking for just another line-of-sight antenna? Absolutely not! That's why I mentioned the advantage of having a multiband rig which can handle HF frequencies as well. The CA-UHV has a threaded fitting at the top of the mast into which

one of the resonators can be installed. The antenna comes standard with resonators for 40m, 15m, and 10m, and there are optional 20m and 17m resonators which you can purchase separately. Decide which bands you intend on working, then select the appropriate resonator. If you travel only during the day, 40m might not be your first choice, but with band conditions as they have been recently, 10m has been great during the day.



*Photo C. When pulling into the garage at night, the CA-UHV folds over to permit easy clearance of the garage door.*

At this time, unless you only plan on operating a single HF band, it might be a good idea to install each resonator and adjust the SWR. I personally do not attempt to operate CW or RTTY while driving, so my suggestions for a mobile installation will focus on the voice bands. If you examine each resonator, you will notice that it has a coil from which an element extends. At the junction of the two, there is a set screw which can be loosened to allow the length of the element to be changed. If you cannot retract enough of the element to properly tune the element, then you must cut the element. Be cautious and cut only a very short amount! It is very easy to cut too much. Fortunately, Comet includes an extra element for each resonator (thanks, guys), but it's better to not need these.

It is important to determine which segment of the band interests you most, and then tune accordingly. For ten meters, I found that I could get about 750 kHz at an SWR of less than 2:1. If you have FM available, you will probably wish to ensure that you have the ten meter repeater frequencies within this range (which would probably be from just under 28.9 MHz to the top of the band). If you have made friends in the Novice and Technician Plus segment, you'd probably want to center your tuning at 28.68 MHz to include this segment up through about 29 MHz. For the 10m band, each centimeter will move the frequency about 500 kHz.

Fifteen meters is another good daytime band, and the Comet CA-UHV will give you better than 2:1 SWR through an almost 300 kHz range. This should let you cover the entire voice sub band for all license classes with no difficulty. Again, if you find it necessary to trim the element be very careful because each centimeter will shift the frequency by about 350 kHz. For forty meters, you will be able to select about a 35 kHz segment with the SWR less than 2:1.

With some multiband antennas, you need to stop the car and change resonators or make some other type of physical adjustment before switching bands. With others you may have multiple resonators pointing in different

directions, but these usually require some type of guying to prevent the antenna from spontaneously bending over at highway speeds. The Comet CA-UHV allows you to put one resonator at the top and another at a ninety degree angle to the main mast. This means that you can operate two HF bands, plus the 6m, 2m, and 440 MHz. Actually, you could add the other resonators, if you added some guying or if you were parked for Field Day or disaster communications support. For most of us, though, five bands is more than enough to keep us busy while on the road.

One of the great benefits of this system is that you can pick and choose according to your needs. If most of my traveling is going to be at night, I may install the 40m and 20m resonators. During the daytime, however, particularly with the sunspot activity we have now, I may stick to 10 and 15 meters — changing resonators is easy.

Incidentally, each has a locking nut, so after screwing in the resonator, make sure you put a wrench onto the locking nut and tighten it. Considering how much you bounce around in the car, it's only safe to assume that the antenna is taking at least that much vibration. I recommend that you pick the lowest frequency band you expect to use and install it on the top of the mast, which will determine the overall height of the antenna. If you choose 40m, the antenna will be just about eight feet tall, which is enough metal in the air to do the job without presenting a

structural challenge. Shorter resonators can be mounted on the side adapter without placing unnecessary stress on the mast.

With the PL-259 mount, the CA-UHV can be easily removed when you park your car at the airport or in a questionable location. On the other hand, when pulling into your garage at night, there's no need to remove the antenna. Just above the base of the antenna is a knurled collar which can be unscrewed then lifted. Once lifted, a hinge in the antenna mast is exposed and the antenna can be laid down to clear the garage door opening or other obstruction. To make this even more convenient, you can rotate the shaft to lay it down in any direction.

#### A few options to consider

I've mentioned that there is a 20m resonator available as an option. I like working 20m, since it offers benefits during daytime and nighttime operations. On the other hand, there are so many "big guns" running high power and significant antenna arrays that you may feel intimidated. Don't let that stand in your way, since signing as a mobile will sometimes catch the attention of that exotic DX station. I've had many times on 20m where I've hooked up with another mobile that I heard in a pileup. There's kind of an interesting camaraderie out there that you might enjoy. Of course there are now more mobiles showing up on 17m, too, and there's now a resonator available for that band as well.

A key accessory that I'd highly recommend is Comet's duplexer. A duplexer permits you to use a single antenna for more than one purpose at the same time. You may be familiar with duplexers through your local repeater if it uses the same antenna for transmission and reception. I have used the Comet CF-706 to allow me to connect my VHF/UHF radio and my HF rig to the CA-UHV antenna. If you have an extended range rig with two antenna connections, the duplexer will let both outputs use this antenna.

#### Summary

Comet has done it again. I've always

been satisfied with Comet antennas, and the CA-UHV is another winner. It has the features I want and it's easy to use. If you are looking for an outstanding multipurpose antenna for your mobile rig, take a good look at the CA-UHV. 73

**SAVE 47%!**

on 12 months of **73**

**Only \$24.97**

Call 800-274-7373

**Pay TV and Satellite Descrambling**  
New ... Year 2001 Edition ... New

**Pay TV and Satellite Descrambling 2001** has latest cable and satellite fixes, schematics, bullet blockers, cubes, etc. \$18.95. **Pay TV Series Vol. 1-11 CD-ROM** \$59.95. **Scrambling News Online** includes piracy \$59.95/yr. **Hacking Digital Satellite Systems IV** \$29.95. Everything listed here only \$99.95. Free catalog.

**Scrambling News**  
4798 S. Florida Ave., #108  
Lakeland, FL 33813-2181  
863-646-2564. [www.scramblingnews.com](http://www.scramblingnews.com)

CIRCLE 36 ON READER SERVICE CARD

<b>Frequencies</b>	7, 14 (option), 18 (option), 21, 28, 52, 146, 445 MHz
<b>Gain</b>	7-54 MHz: 0 dB
	146 MHz: 3.4 dBi
	445 MHz: 2.15 dBi
<b>Max power</b>	120 W SSB
	52 & 146 MHz: 200 W SSB
<b>Impedance</b>	50 Ohms
<b>Weight</b>	460-580 grams
<b>Length</b>	1.9 meters (maximum with 40m resonator)

Table 1. Specifications.

[www.mouser.com](http://www.mouser.com)



Available From:

**MOUSER**  
ELECTRONICS

A  COMPANY

[sales@mouser.com](mailto:sales@mouser.com)  
800-992-9943

## A Safe LED Optical Transceiver System — Part 2

*Last month, we got into the basics of the LED transceiver system. This month, let's get into a more detailed description of this system and cover the tripod mounting and aiming scheme. Additionally, we will cover the main mount that holds all components together and makes a tight package that is rigid for transportation. Also covered is the LED transmitter schematic and modulation scheme.*

I am leaving the receiver local oscillator system description for next month, as the engineering schedule is being pushed as fast as we can to get testing done on a simple replacement for the LO we used, a "synthesizer" local oscillator. Just need time for construction and development to complete the receiver system. Let's get back into the construction, taking up where we left off last month and covering focus and making the system rigid.

Here are more tube and mount construction details. In its finished form, there are two tubes of 4-inch PVC pipe (colored black internal), one holding the receiver and its Fresnel lens, and the second tube holding the LED, lens, and the rest of the transmitter circuitry. The two tubes are held together in a binocular fashion to keep them symmetrical and both pointing in the same direction. The tubes were separated by

rectangular aluminum tubing holding both plastic tubes firmly in place. Actually, the aluminum rectangular tubes were scrap aluminum 4 GHz waveguide used for the main support, and an 8 GHz waveguide short section for the scope mount. Common shower mounting molding sections were bandsawed into short "U" brackets used to position the plastic tubes in alignment with the outer edge of the "U" channel. The base of the "U" channel is bolted to each side of the main support aluminum tube, making a rigid arrangement for both 4-inch pipe assemblies and the center support member.

On top, centered between the TX and RX assemblies, a section of smaller rectangular aluminum was used to mount a rifle spotting scope for aiming of the system. The spotting scope positioning is accomplished by using an 8 GHz section of aluminum waveguide about five inches long. One end

(front) has a screw down firmly through the body into the main rectangular center support; the other end has a short section of the top of the tube cut away, leaving a 3/4-inch tab on the bottom. This tab is slotted with a circular file for horizontal alignment of the rifle scope.

An "L" bracket is fixed to the upper portion side of this tube and used to mount the rifle scope by cutting and shaping the short bottom section of the "L" bracket to accept the original scope mounting mechanism. The front of this "L" bracket is fixed to the top front side of the small mounting section. The rear of this bracket is slotted in a vertical manner, giving vertical adjustment for the spotting scope.

After the system is constructed as far as optics, electronic circuitry, and mechanical mount considerations go, alignment and prime focus for each of the receiver and

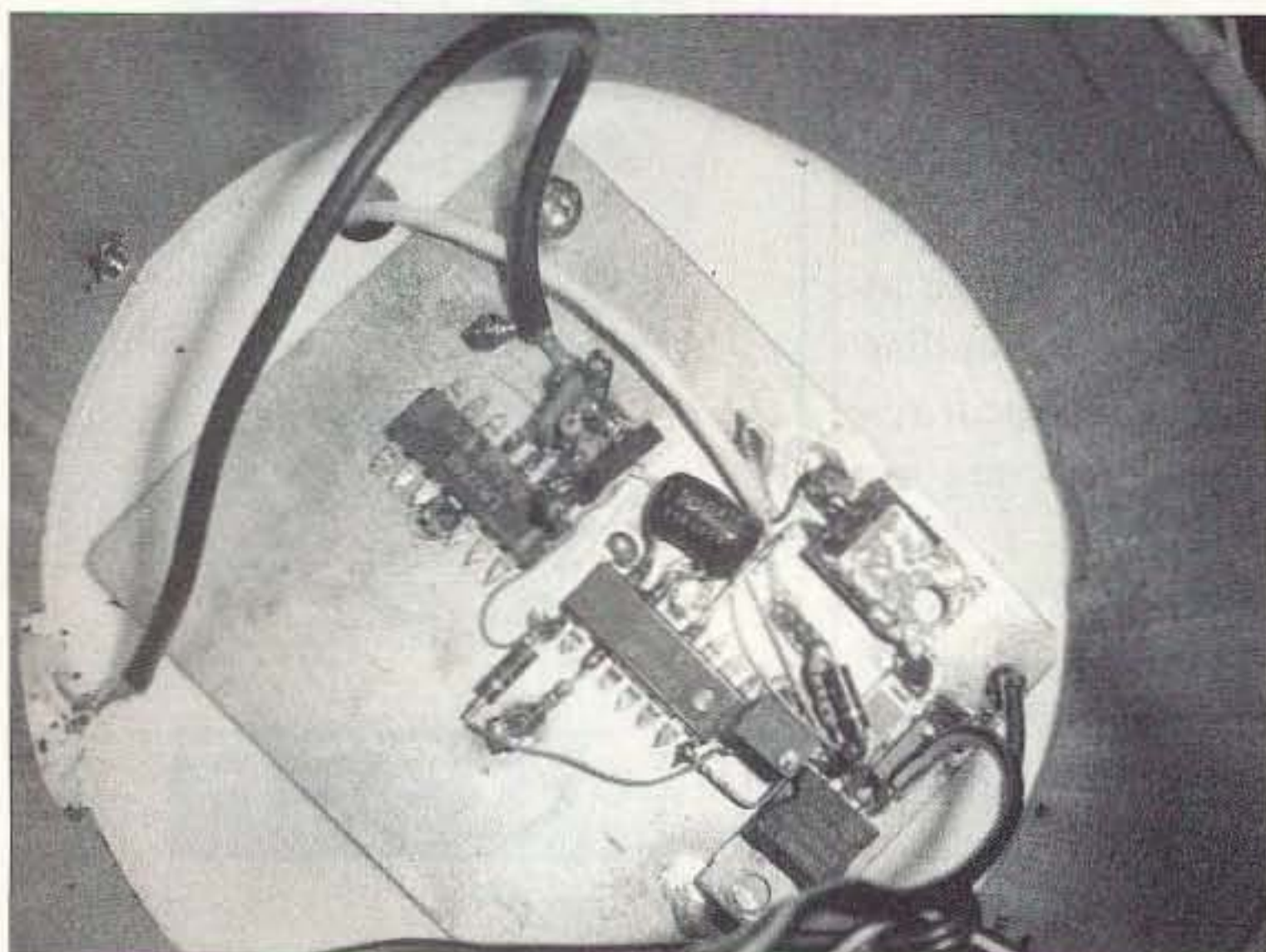

*Photo A. Photo of the LED transmitter showing the mic amp and PLL 4046 chip that drives the LED mounted on other side of the two pipe caps cemented together back-to-back.*

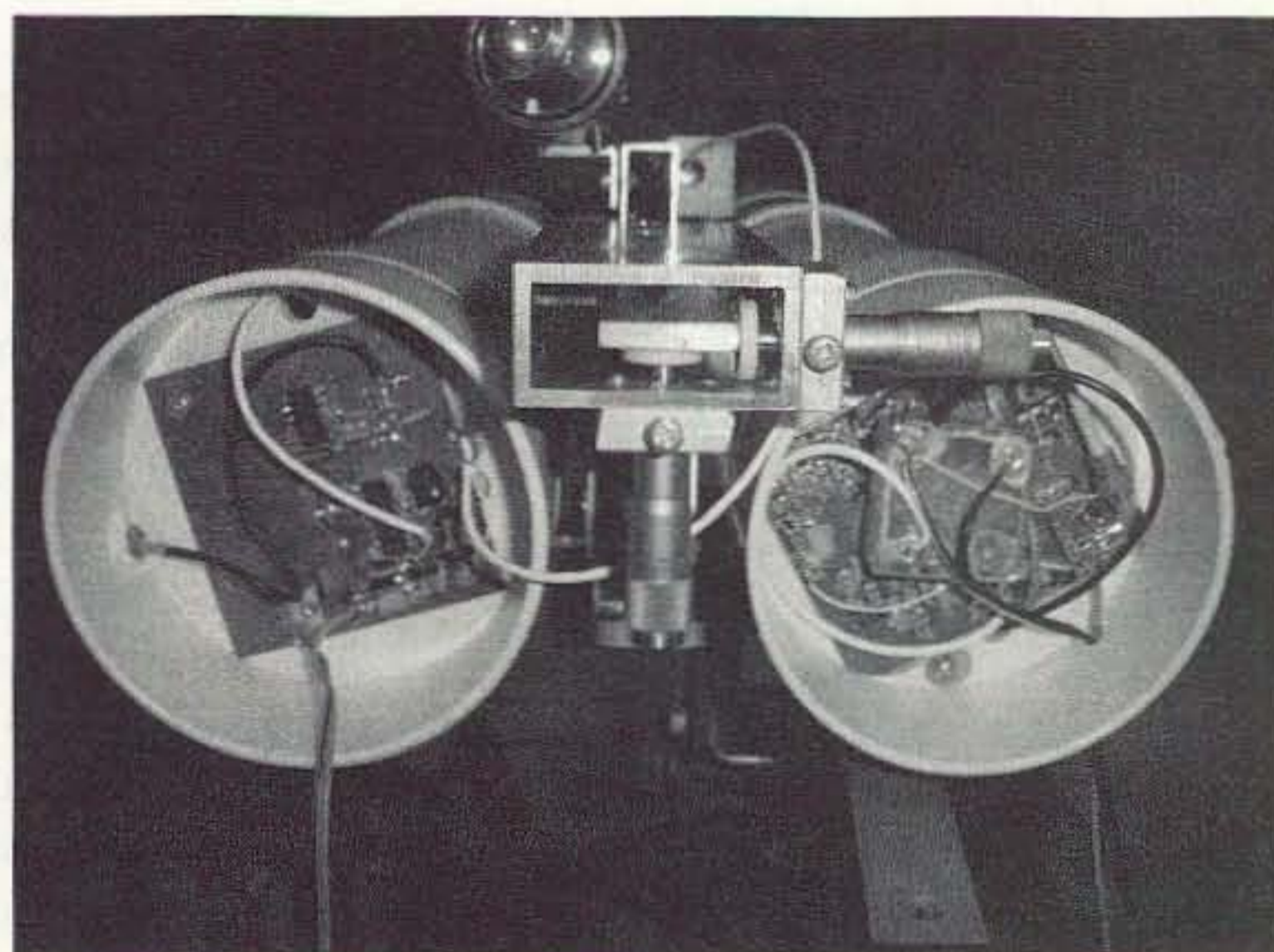

*Photo B. Photo of mounting for both 4-inch TX and RX main optics housings mounted together with aluminum "U" brackets on each side of the main rectangular support.*



transmitter optics and electronics need to be addressed. The receiver detector is centered in its housing and adjustment is made by sliding the lens in its splice union for best received signal. The transmitter is done similarly by watching the LED spot for best focus on a target about 10 to 15 feet away. Additionally, use a calibrated caliper to center the LED and detector within the cap where they are mounted.

To accomplish distant alignment of both transmitter and receiver and rifle scope, a small reflector is positioned a few hundred feet away and the system is pointed towards the remote reflector (I used a bicycle reflector). The LED transmitter and receiver are positioned using a tripod for best return RF as detected on the 2 meter HT's S-meter. Use an attenuator to prevent overloading of the HT. Align the rifle scope at the remote reflector to calibrate both the optics and the rifle scope. See **Photo C** for scope mounting details.

Once you are satisfied with focus, marks are made on the tube to locate where this focus point is situated. These marks locate best focus position for the end caps and splice union joint. These marks will then be used to position the caps and splice unit to confirm that they have not moved from prime focus while you were drilling retaining holes to be tapped for 6-32 screws. The plan here is to insert three screws threaded into the soft plastic cap and pipe material. The screws will hold the caps and lens assembly in firm position, giving the entire unit some rigidity.

On my unit, I drilled three concentric holes evenly spaced in convenient places and tapped them for 6-32 screws to fix the assembly in place. You might want to fix the caps in place temporarily with duct tape while drilling to prevent movement of the material. Don't even think of using glue for the plastic, as when repair or modifications are required, you will be "stuck." The 6-32 screws can be taken apart easily, and give simple access to the internal components should servicing or adjustment be required.

Retest again, with the remote bicycle reflector mounted 100 feet or so distant. The LED was pointed towards the reflector, noting the return signal strength from the return reflection on the S-meter of our 2 meter HT. It was adjusted for maximum S-meter reading. Then the two screws for vertical and horizontal scope alignment were adjusted to bring the scope into alignment, placing the reflector in the crosshair of the spotting scope.

The following is an E-mail transmission from Kerry N6IZW, telling his views about the system he designed and the excitement

we both feel about this safe and simple setup. Here is the message Kerry addressed to members of the San Diego Microwave Group:

Subject: Having fun with through-the-air optical communication

The ARRL 10 GHz & Up contest held each year also includes optical communications over a minimum distance of at least 1 km. I played with low power lasers a few years back and did not like my first experience at trying to communicate over a two mile path. We were using surplus 5 mW lasers mounted on heavy-duty camera tripods and spent probably most of an hour trying to aim one of the lasers at the receiver at one end (we finally did make it). The pointing was way too critical for standard pan/tilt tripod adjustments, and when we did get on target, the intense laser light left Chuck WB6IGP with a headache for two days.

Two weeks ago, I decided to try again using current LED technology for the transmitter. I constructed one transmitter consisting of a Radio Shack red LED rated at 5000 mcp @ 20 mA (660 nm) at one end of a 12" long, 4"-diam. plastic sewer pipe housing with a Fresnel lens cut from a sheet-reading



**Photo C.** Photo of the rifle scope mounting on top of the main rectangular support. The "L" bracket for the scope mounting is slotted on the rear end of the main mount for vertical movement to align to scope to the LED light source. The bottom of the mount rear is slotted for horizontal alignment of the same scope.

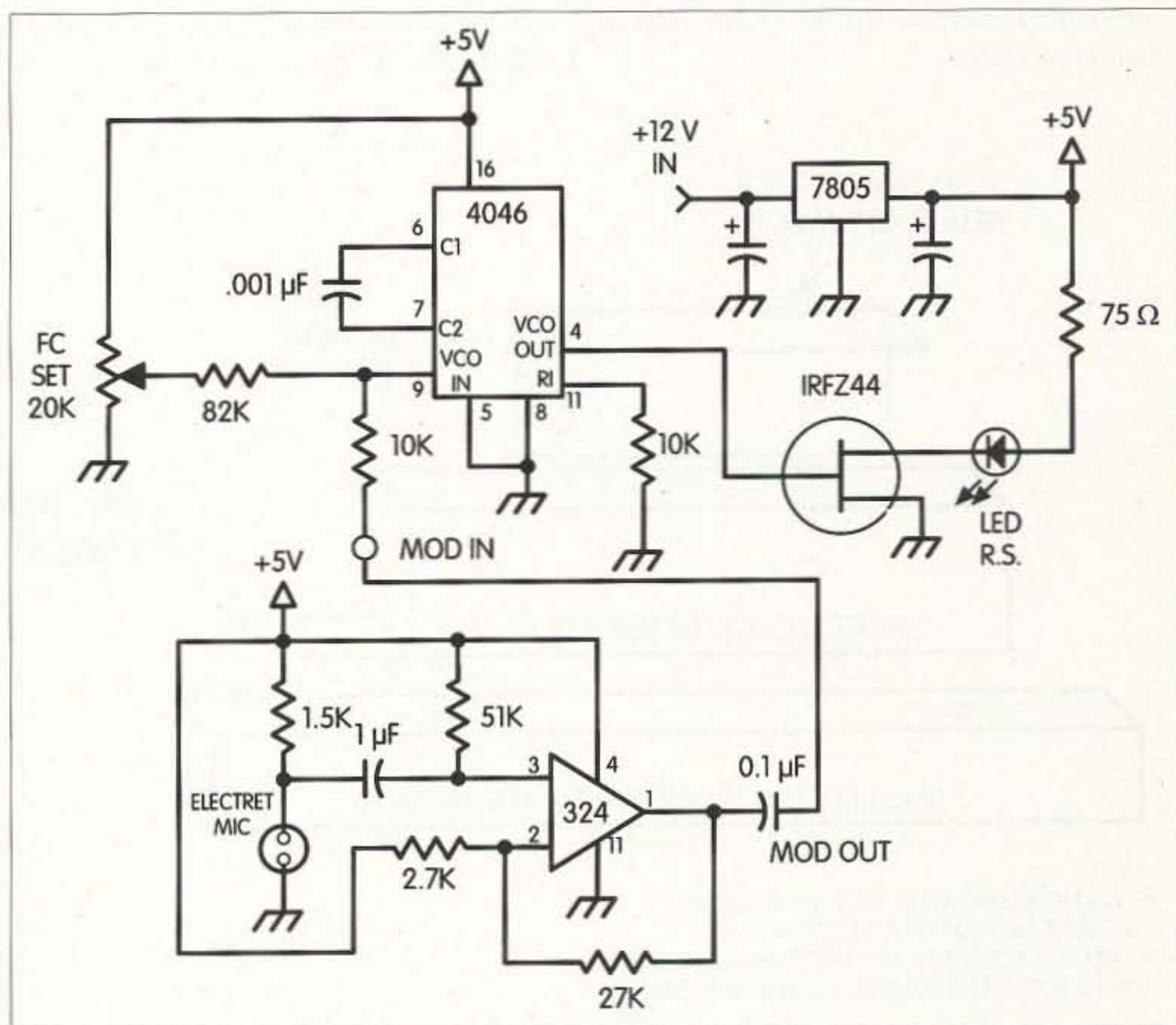

**Fig. 1.** Transmitter schematic. Construction made dead-bug-style on a small piece of copper PC board material. The LED is mounted inside the front section of two caps cemented back-to-back. The rear cap assembly houses the electronics for the modulator (LM-324) and the VCO PLL chip (4046). The 75Ω resistor is really adjustable from 75Ω-200Ω. Start with 220Ω and adjust so that 34 mA max. flows in LED.

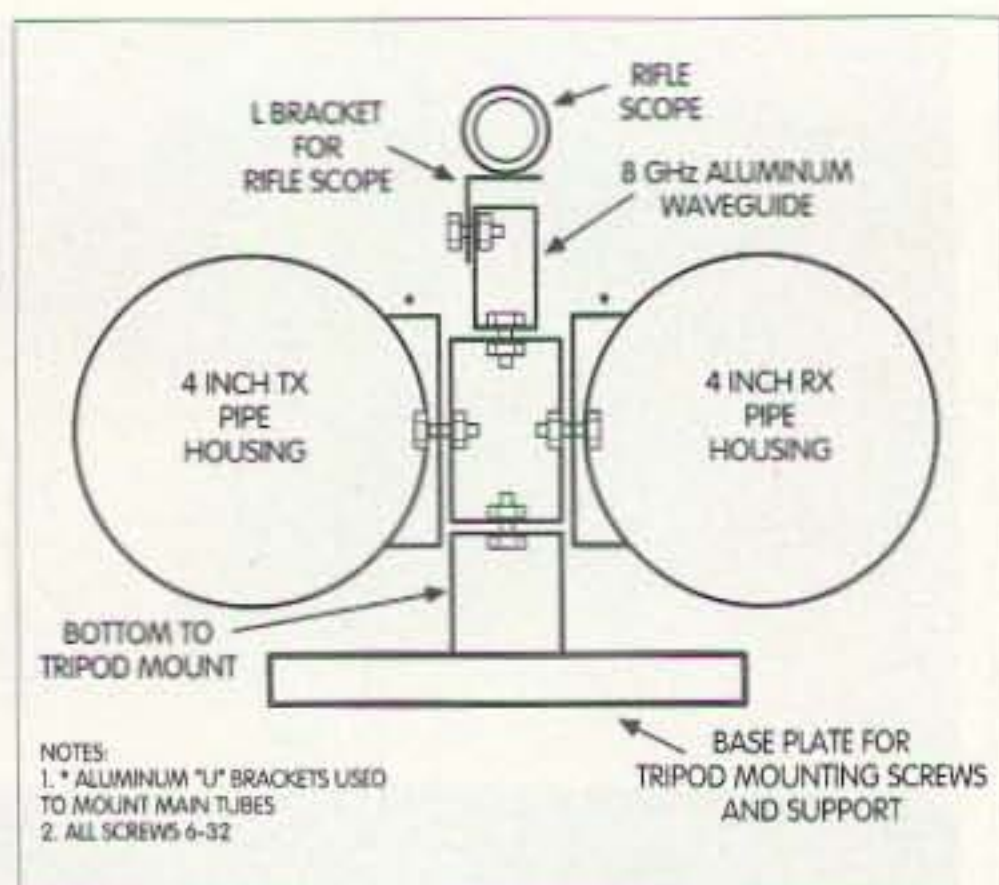

**Fig. 2.** Rear view of mounting method to hold both 4-inch pipes to large rectangular center support and "U" brackets mounting and holding the pipes together. The main center mount was a large section of rectangular waveguide, but any stout aluminum tubing could be used here. Another section is attached to the main bottom tube to form an extension to attach to a tripod base plate, giving clearance for the 4-inch tubes.

magnifier on the other end. The LED is driven by a power FET connected to the output of a 4046 PLL IC running as a VCO at 35 kHz. This provides a 30 mA average square wave drive to the LED. An electret microphone and op amp provide audio to modulate the VCO for NBFM communication.

The receiver consists of the same lens/pipe arrangement with modified surplus I/R remote control receiver. The I/R receiver was chosen because it appears to have a nice large area PIN photo diode with no I/R filter in front. The unit circuitry was modified to provide linear output as a preamp rather than a digital output for control purposes. The received 35 kHz from the preamp is upconverted to 145.035 MHz through a simple upconverter consisting of a 3036 PLL circuit and an SBL-1 mixer. This allows the use of a standard 2m radio as the NBFM receiver. It also allows a 2m all-mode radio to be used in SSB mode for weak signal detection and initial alignment.

The initial testing and alignment was performed using a bicycle reflector mounted out about 250 feet. The transmitter and receiver were mounted on separate tripods as well, which was adjusted to point at the red spot returning from the reflector when the received signal was maximized. There are noticeable problems with parallax at this distance. This was followed by pointing the two units at each other over the 250-foot distance and measuring the carrier to noise. The values indicated the system should be capable of perhaps 4-8 miles.

I completed two transceivers with the help of Chuck. We tried an across-the-yard shot, which was of course very easy with full

quieting of the FM receivers. On 2/24, we set up about 2.2 miles apart and tried again. The hardest part was spending a few minutes locating each other, as Chuck had moved to a location on Mt. Helix which was not where I was expecting him. We briefly used strong flashlights (and 70 cm radios) to locate each other, and aligned the scopes on the transceivers to the flashlight spots. We immediately had usable signals, which were improved to full-scale S-meter deflection and full quieting upon additional position adjustment.

The red spot is very noticeable but not at all hard on the eyes, and the pointing is very reasonable for a good tripod setup (same tripods we use for our microwave contacts). Using a calibrated S-meter on my end showed the carrier-to-noise to be still at least 14 dB, so we'll try 4+ miles next and are easily ready for a few contacts during the August/September contest. The contact was made at night, and I believe we can at least make the required 1 km contact during daylight as well. Kerry N6IZW.

### LED transmitter construction tips

See Fig. 1 for the transmitter LED VCO and modulator for this system. Construction is dead-bug fashion on a small section of copper circuit board, as the circuit is quite simple. Dead bug infers mounting the chips upside down and holding them to the PC board with a dab of RTV. After the RTV sets, solder the ground pins directly to the copper foil and mount the components in mid-air. If you don't want parts to move, use a dab of RTV to hold in place after soldering to required IC pins — just remember, "A little dab will do ya."

The electret mic is mounted on one side of the rear pipe cap through a hole in the cap, and RTV'd in place. The transmit circuitry is mounted in the rear of the pipe cap assembly. The LED and its mount, a small piece of PC board, are used for positioning in the center of the upper (front) of the pipe cap. When the LED circuit is finished and assembled but not permanently fixed in place, focus the LED and adjust its beam for the center of the Fresnel lens. To be sure it's centered, rotate the lens or LED and the beam should stay centered as best as possible. This is somewhat critical, or else the LED light beam will be skewed coming out of the lens and not point properly to a remote target.

Additionally, care should be given to cut out the Fresnel lens, which is circular in nature. The lens, when cut out to the diameter

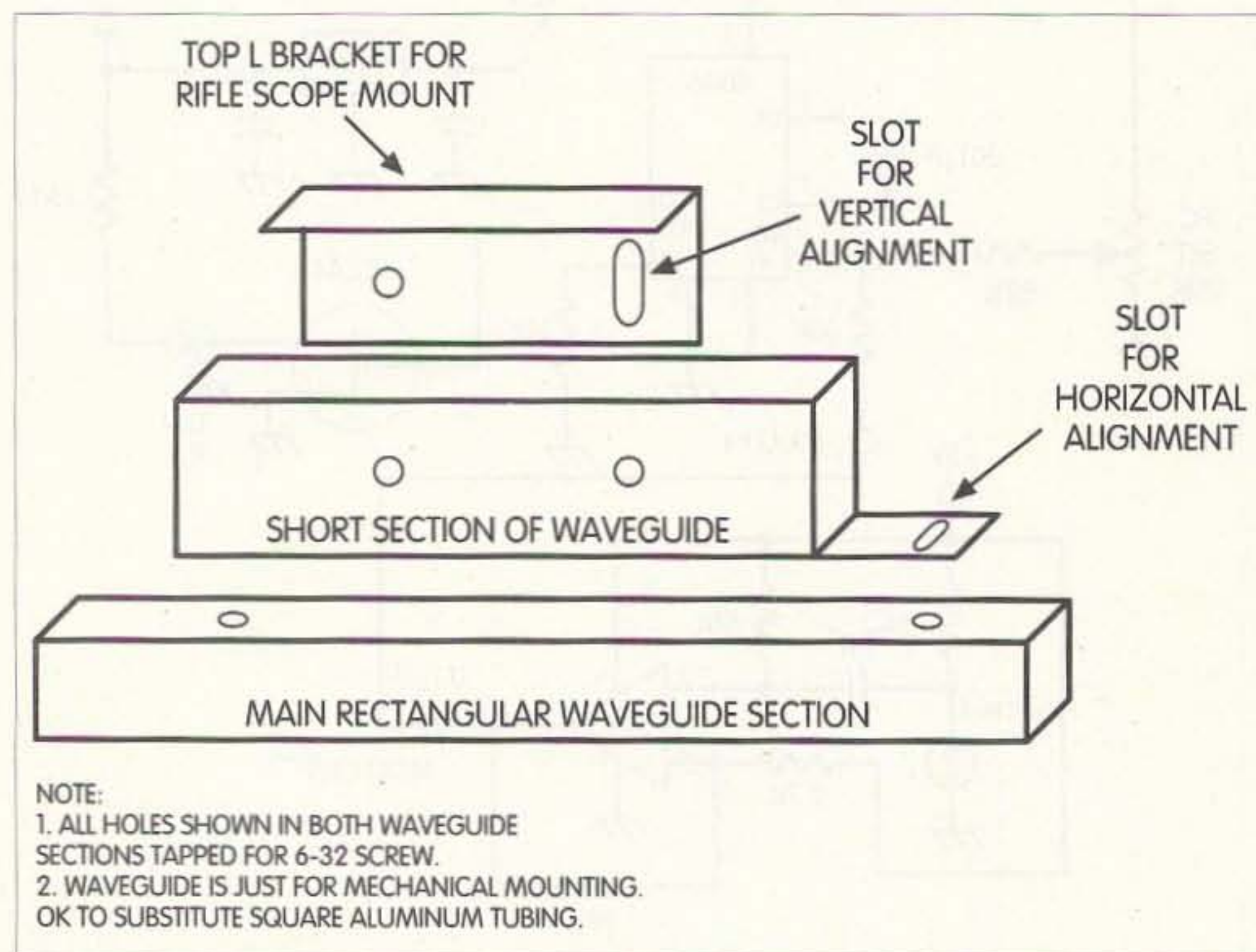

**Fig. 3.** Method of securing rifle telescopic sight to center rectangular support. Detail shows method of vertical and horizontal easy adjustment of orientation of rifle scope to transmit beam of LED transmitter when reflected off of remote reflector. This reflector should be at least 250 feet away to avoid parallax problems. I used a car's red rear reflector about 5 houses distant for my first trial alignment.

# ON THE GO

Mobile, Portable and Emergency Operation

Steve Nowak KE8YN/4  
1011 Peacock Ave. NE  
Palm Bay FL 32907-1371  
[ke8yn@netzero.net]

## It's That Time of Year

*As I write this, I am looking ahead to the start of the hurricane season. As I try to lay out my plans that I may need to rely on, I thought that I'd share them. I'm curious as to how these may compare to how you look at things in your area. While I normally am pretty good at planning, this year is going to tax my ability quite a bit.*

On one hand, I'm involved in the disaster services communications world, while on the other hand my daytime job is as director of a department in a hospital. This means that what I plan and put into place may have to work without my being as involved in its execution as I'd like. Therefore, I need to develop as comprehensive a plan as possible. Depending upon the particular situation, I may be operating as net control, or I may be directing a portion of the hospital's activity, and totally out of the communication arena.

Fortunately, with hurricanes, as opposed to many of the other forces of nature, there is a bit of advance warning that we enjoy. The hurricane activity level is forecast months before hurricane season starts. Tropical depressions are monitored as they form hundreds of miles away, to see if they strengthen and to determine their track. We usually expect a fairly long period to watch the system develop or diminish. On the other hand, when dealing with other natural disasters there may be little or no warning. The offset is that while a tornado forms quickly and strikes suddenly, it also dissipates in a short while, whereas a hurricane can continue for quite some time.

### Preparatory stage

I break up my plan into several stages, identify my needs, and then try to determine how to best meet those needs. The first stage I call the preparatory stage; it includes all that quiet time when we prefer NOT to think about disasters. During that quiet time, we need to handle such things as the identification of those agencies which will be served and what their needs will be. Once this is determined, it is important to identify who the contacts will be at the served agencies, and who the hams are who will

serve them. These people need to get to know one another so that when the need arises, the communicator will be able to step into the picture and get started with no need for training or familiarization.

Identification badges or cards may be needed to cross police lines or enter a facility. This needs to be handled during the preparatory stage. You need to seek volunteers and let them know their assignments are critical so that they may familiarize themselves with their assigned location. Knowing what services are available in a given facility will tell the amateur radio operator what they will (or won't) need to provide for themselves. A ham assigned to a hospital can expect to have power and water more readily available than one sent to perform

damage assessment in the field. On the other hand, the ham assigned to the field may be able to use a handie-talkie or a mobile rig, while the one in the hospital may have problems unless an external antenna is available. These matters can be better planned for, but only if there is an understanding as to the pairing of hams and assignments long before there is a need.

### Imminent stage

In the imminent stage, it is recognized that disaster is possible, but it has not yet presented itself. Not every disaster will permit this stage, since an earthquake or an explosion may offer no advance warning. If you do have an awareness of a significant threat, this is the time to activate certain



**NEW**

**IC-756 PRO**  
32 Bit Floating Point DSP  
HF thru 6M



**ICOM**

**IC-746**  
HF/6M/2M/100 Watts



**New Pricing**

**IC-706 MKIIG**  
HF + 6M + 2M +  
440MHz



**Call For Alinco Specials**

**DX-70TH** Compact, 100W, HF



**ALINCO**

**DR-610T**  
2M/440MHz Mobile/Base



**Hi, To All The Folks At SEAPAC**

**DJ-V5TH**  
V/UHF, FM  
Handheld



**3300 82nd St. #E, Lubbock, TX 79423**  
**1-800-588-2426**  
806-792-3669 FAX 806-785-3699  
[www.rad-comm.com](http://www.rad-comm.com)



personnel. If bad weather is brewing, for example, SkyWarn is normally activated. Merely activating a net is not enough, however. The Weather service will need to have their ham on site. Don't expect that this person can handle the SkyWarn Net alone. The bad weather that threatens one area is coming from somewhere else, and that area may also be the responsibility of the same weather station. They may be tracking storms in three or four counties, and their amateur operator may be switching frequencies to communicate with the various weather nets, so a net control station is also needed.

Obviously, some of the public service agencies may want their ham radio operator available and on site. This may be at the communications center that handles the emergency 911 calls, the police department, or the Emergency Operations Center. If emergency shelters are being prepared, it's pretty likely that they will want to have their communicator on site.

Don't forget that while you are providing communications for everyone else, you need to take care of doing the same for yourself. Assign a command frequency so that the communications leaders have a place to compare notes. Make sure that all stations on the frequency know what the secondary frequency will be if the primary repeater frequency is lost.

The demand may be high during the imminent stage, even though there may not be a lot of activity for individual hams. In many cases there may be many hams involved, but the net control station may be

the only active station. It can be very taxing to be on a heightened state of alert for a long period of time with nothing to do. At this point, everyone wants to get involved and volunteers are plentiful, but it is important to budget your people carefully (more on this later). Incidentally, this "hurry up and wait" period is one reason that a good book is important for your "grab and go" bag!

### Disaster stage

Actually, from a communications standpoint, this is the easiest portion of the activity. From almost every other perspective it is the hardest. The need for communications is temporarily at a low point. Unfortunately, the reason there may not be a lot of communications required is because everyone is busy hunkered down in a safe place (hopefully). Don't feel unwanted — this is the communications lull before the storm.

### Immediate post-disaster stage

After the disaster occurs, there is a time during which confusion is the main ingredient. It is obvious to everyone that something has happened, but the extent of the event and its effects are unknown. The operators who have been standing by may now be used extensively. The stations that have been standing by may be called upon to provide an overall description of what has happened. Is there power? Phones? If not, where has it been interrupted? If phones are not available, then it falls to us to identify the acute problems that must be addressed. Areas that have sustained damage may not present the major problem, since additional damage may not be a threat. On the other hand, fires, chemical leaks, etc., can and will create larger problems if not addressed, so it is critical that these be identified and addressed as soon as possible.

At this time, there are a couple of actions that might be necessary. Frequency control is critical at this time. I think it is a good idea to assign one operator as the frequency coordinator. Everyone should be aware of the backup repeater and the backup simplex frequency. A frequency coordinator should periodically check in with net control on the main net frequency, and then keep tabs on the other repeaters in the area to determine which are working and can provide coverage for an appropriate area or function. As the demand for communications increases, the frequency coordinator is the person to determine which networks should be on which frequencies. Again, don't forget to reserve one frequency (if possible) for the

use of the communicators themselves. This frequency may be useful for assigning hams to their locations, accepting check-ins for hams arriving in the area, etc.

### Rescue stage

Once the authorities have sorted out what has happened, the rescue stage begins. At that time, efforts are made to reach and assist those who have been affected by the disaster. We, as communicators, will be directed as to what is expected of us. Our main job in this stage is to respond based on everything we planned for so far. This may include providing cross-communications from one agency to another (e.g., National Guard to local fire department), since they often have totally different radio systems for their internal use. Damage assessment efforts may begin, and we may either be asked to provide communications for the assessment teams, or to perform the assessment ourselves. This stage can be very intense and place a high demand on the hams. You should assess the stations that were active during the imminent stage and determine if they can stand down for a while and be relieved by others, to grab a snack or a nap. While the adrenaline is still flowing at this point, sooner or later people, as well as batteries, need to recharge.

### Sustainment stage

This is perhaps the most difficult stage, particularly since it may be the least glamorous. While everyone wants to help out at the very beginning, this desire cools after a while. People begin to drop out of the picture; employers expect their people back on the job. Families are waiting, etc. Hams who responded in the beginning may be experiencing burnout by this point. People who can run on adrenaline and coffee for the first day or two cannot sustain this indefinitely.

For hams, the sustainment stage may present some very real possibilities. There is not only the need for communication for public service agencies and at shelters, but this is the point at which health and welfare traffic becomes important. In today's CNN instant news, World Wide Web, cellular telephone society, not hearing from someone in a disaster area can be even more traumatic than in the past. It is important to have operators who can provide support after things begin to settle back down.

Well, those are some of the ideas I'm working on. How's your plan going? If you have any good ideas to share, drop me a line, a note, etc.

Ad Sales  
call Evelyn Garrison  
425-557-9611

## Repeaters

6 & 2 m & 440 On your frequency

\$399.95 & \$499.95

## Repeater Controllers

RC-1000V \$259.95 / RC-100 \$129.95

## Micro Computer Concepts

8849 Gum Tree Ave

New Port Richey, FL 34653

727-376-6575 10 AM-10 PM

e-mail n9ee@akos.net

http://mcc.stormfan.com

Dr. Rick Olsen N6NR  
Western Washington DX Club  
P.O. Box 538  
Issaquah WA 98027-0538  
[n6nr@arrl.net]

## Phoenix and Clipperton

*Pretty much half the year has gone by already. It's time to start looking through the log to see if you qualify for any of the new awards that are available. One award I don't want you to forget is the DXCC Millennium Award offered by the ARRL. As you can see from the copy of my own award that I received back in April, it is a handsome certificate, worthy of any shack wall.*

This award is not all that difficult to obtain. I am glad too that the folks at League HQ took our lead by offering a DXCC-ish certificate that embraces the no-QSL spirit of the DX Dynasty Award. I'm just poking fun, of course, which is my twisted way of pointing out that QSLs are not required for this DXCC certificate. All you have to do is send in a log and a "ten-spot," and it's yours. Here are the official rules from the ARRL Web page:

1) The DXCC 2000 Millennium Award period begins 0000 UTC 1 January, 2000, and ends at 2359 UTC on 31 December, 2000. All contacts must be made during this time period.

2) The DXCC 2000 Millennium Award certificate is awarded for working 100 or more of the entities on the ARRL DXCC List. Contacts may consist of any combination of bands or modes.

3) No endorsements of any kind are offered. Certificates are dated, but not numbered.

4) The applicant must certify on the original application the authenticity of log extract information for contact with the 100 entities on the DXCC List. No QSL cards are required for this award.

5) The DXCC 2000 Millennium Award is separate and distinct from the traditional DXCC awards programs. Qualifying for the DXCC 2000 Millennium Award does not provide credits for the traditional DXCC awards programs.

6) The DXCC 2000 certificate is available to members and nonmembers.

7) Applicable rules of the DXCC program, such as location of stations and conduct, apply to the DXCC 2000 Millennium Award.

8) The official application must be used to facilitate processing. Application forms

are available for an SASE, or an SASE with 1 IRC for amateurs outside the US. Applications may also be downloaded from the Web. The URL is: [http://www.arrl.org/awards/dxcc]. Mail requests for applications may be sent to: DXCC 2000 Millennium Applications, American Radio Relay League, 225 Main Street, Newington CT 06111 USA.

9) Send completed application (within one year of the close of the DXCC 2000 Millennium period) to ARRL HQ along with \$10 US to cover costs of printing, postage, and handling. So what are you waiting for? Get busy and start pouring through your log to see if you qualify!

### More on the DX Dynasty Award

First off, I have to ask all of you not to send your DX Dynasty award applications to me. The wonderful folks at Never Say Die headquarters feel lonely and underutilized if they don't receive them directly. Besides, they are the ones who have the certificates, not me. As for those of you who sent your applications to me, don't worry, be happy. I have already forwarded them on to New Hampshire.

And as for the DXD entities list that I published back in May, I would appreciate it if all of you would take a look at the list to see if I have gotten everything on the list that should be there. I also want to know if



Photo A. The ARRL DXCC Millennium Award.

there are some things on the list that you think shouldn't be there. Keep in mind, though, that the DX Dynasty Award has entity inclusion criteria that differ from that set in place for DXCC, and others. The DXCC countries list is intended to be included as a subset, however.

### The Central Arizona DX Association Reunion

I can't believe that it has been over 25 years since the formation of the "Arizona DX Ring." This was a group of Phoenix area DXers that kept a list of each other's DXCC needs, and would give a call to anyone on the list who needed a county that they were listening to, with information on band, mode, and depth of pileup. This was the prototype of the DX cluster, and later became a formal organization that is now known as the Central Arizona DX Association.

I recently received a notice from Bob K7BHM that a reunion of the charter members of the CADXA is going to be held in September. Here is a brief synopsis of the early days of the CADXA that Bob sent to me.

"It was in the early to mid-summer of 1974 that a small group of radio amateurs, most of whom lived in the east Phoenix valley, decided to combine for their special interest, DXing, and formed a DX Association. Several of these DXers were members, or had attended meetings of the Arizona DX Club, but found that those meetings were not really satisfying basic DX needs. That club was made up of many 'old-timers,' who oftentimes wanted only to socialize rather than discuss DX. The original sixteen members of this new DX Association, which was appropriately named the Central Arizona DX Association [to distinguish itself from the (Arizona DX Club)], included:

"Wayne W7RUK (W7QS/NN6R); Jerry W7CKW; Ron K7NXH (N7RR) (SK) (the originator, and considered the founder of CADX); Tom WA7VGX (KE7QK); Al K7PFU (W7XA); Dale W7ATF; Chuck WA7RKR (KD6VS); Warren WØSIP/7 (K7SA); Bob K7BHM; Bob K7NWB (K2KXG); Allan WA7YRP (N7RP); Mike K7QYY; Mike WA7HRE (N7MW); Rick, WA7CNP (N6NR); WA7RRR; and WA7YNV.

"Because this group of amateurs lived relatively close to each other in the East Valley (Scottsdale, Mesa, Tempe and Chandler), for the first several months of late 1974 and early 1975, they alternated meeting at each other's QTHs. As the club grew in number, however, it was necessary to locate a permanent meeting place. The old Sands Hotel on East Van Buren in Phoenix was selected as the first meeting location, primarily because one of the members' (WA7CNP/N6NR) father was the CFO for the owner of the Hotel, and we had a great deal for access to the meeting rooms. We started meeting at the Sands in May/June 1975.

"In November and December of 1974, the need for a constitution was determined to be necessary, not only to help formally establish the CADXA, but also to become affiliated with ARRL. The constitution was completed with the help of several CADXA members, and was officially published and released on January 1, 1975. This date is considered our Charter Member date, as well as the anniversary date. It is important to state here the original purpose of the CADXA:

"The purpose of this group is to bring together radio amateurs interested in DX; to promote this common interest through mutual assistance, coordination, and cooperation for all members to achieve DX; to

encourage and assist proper operating techniques, ethics, and standards; and to participate in the exchange of knowledge, methods, or other expedients that would be mutually beneficial to the members in achieving DX accomplishments.'

"Charter membership was also established by Article II, Section 3, of the by-laws: 'Those persons attending the January, 1975, meeting in person, or by proxy, shall be deemed to be Charter Members.'

"Full membership would be granted upon payment of dues, which was \$ .50 per month, and formal, written acceptance of the Code of Ethics of this club.

"One of the first items on the agenda for the CADXA in late 1974 was the election of officers. At the November meeting, it was unanimously agreed that Wayne W7RUK (W7QS/NN6R) would be our first president. Early records do not exist, but it is strongly believed that the Vice President selected was Al K7PFU (W7XA). Our Secretary/Treasurer was Chuck WA7RKR (KD6VS)."

There is much more to this story, and to hear it, you'll have to attend the reunion in person. It will be conducted as part of the regular meeting of the Central Arizona DX Association on September 7 of this year. For those of you who are familiar with the area, it will be held at the PARA Club in Tempe. Anyone interested in attending, please contact Bob Davies K7BHM, CADXA Historian, at (480)839-3728, or via E-mail at [bdavies@sfamipec.com]. I'll have another reminder next month.

### Clipperton 2000

With all the hoopla over the recent DXpeditions to the new countries that have challenged us in the first half of this year, I was afraid that we would soon forget the most excellent operation by the folks who planned and manned FOØAAA. So I took a trip on the Internet to the Clipperton 2000 Web page that is maintained by Doug N6RT, and found a wealth of information on this successful outing [http://www.qsl.net/clipperton2000]. These guys did a marvelous job of getting all us randy DXers into the log. Speaking of logs, just have a look at the size of the first batch that arrived at the post office after the guys got home. If you think that a DXpedition is all fun and games, just remember the old police officer's maxim that goes, "You're not done until the paperwork has been completed," or words to that effect.

Just to give a flavor for what the team experienced, here are some excerpts from the story entitled CLIPPERTON 2000 — THE STORY, by Mike Goode N9NS [(c)

## Central Arizona DX Association



N7KJ – 6545 East Montgomery Rd.  
Cave Creek, Arizona 85331

Photo B. The emblem of the Central Arizona DX Association.

2000, Mike Goode] that is included on the Clipperton 2000 Web page.

"Finally, at dawn on Tuesday, February 29th, Leap Year Day, we sighted our destination. 'Sighted' is hardly the proper word, as the island is so flat all we could make out were several groups of palm trees that appeared to be growing out of the water, and Clipperton Rock, which loomed darkly on the horizon. As everyone was on deck straining their eyes to see details on the small island, the captain cruised around to the west side, trying to find a spot he knew was suitable for landing. It should be noted the Shogun and its crew were no strangers to this place as they go to Clipperton once or twice every year on fishing charters. Also, it was the ship NASA chartered in 1996 as their support ship during a 6-week scientific trip to the island. By 9:00 a.m., the captain had found a spot and sent two crewmen in a launch to check things out. They were not happy with the landing conditions, the surf being rather rough, so it was decided to cruise around to the east side to see if the conditions were any better. So with all of us waiting impatiently we circled the island. We cruised about a half-mile offshore, which gave us a good look at various features like Clipperton Rock, two wrecked Mexican fishing boats, and the small shack at the NASA site. Everywhere around the island there were huge waves crashing onto the reef! Sometimes they raised so high as to obscure the island, and when they broke they sent clouds of spray soaring downwind. The sight of these waves and the mist blowing across the island was sobering to us, to say the least.

"We were beginning to have second thoughts about whether this trip was a good idea! We were committed to it though, so eventually after the ship had circled around to the original landing spot, the captain announced we were going in here. So at 1:20 p.m. local time (we stayed on California time, PST), with life jackets donned and a weak grin on their faces, James 9V1YC, Willy HB9AHL, and Bob K4UEE jumped into the Zodiac. With Bruce, the ship's co-captain, piloting, they were off! As the rest of us watched anxiously from the ship they approached the reef and then disappeared briefly as a wave built up behind them.

"Moments later, they popped back into view, dry and nearing the beach! We all sighed in relief to see that the landings could be accomplished safely. I was on the third trip in, and what a thrill it was to approach the reef and watch the waves build up and then crash down. How would we ever get through that I asked myself. It was quite a



*Photo C. I wouldn't say that this photograph will surpass the victory on Iwo Jima, but I predict that it will be remembered in the DX Hall of Fame.*

ride — a quick rush on top of the wave, then boom! We dropped down onto the reef, as Bruce skillfully brought the launch up to the beach through a small gap in the reef. It sounds easy, but as we found later, it wasn't always that way!

"Within an hour, we had some of our gear and six members on the island. Now a new

menace appeared in the form of a line of dark ominous-looking clouds approaching from the east. Our worst fears were realized, when a few minutes later the wind picked up and sheets of rain began falling. As we struggled to put the first tent up, the wind and rain intensified. The intensity of these tropical squalls can't be described —



*Photo D. I've always wanted to go out on a rare DXpedition, but after one look at the pile of QSLs that comes in, I'm not so sure.*

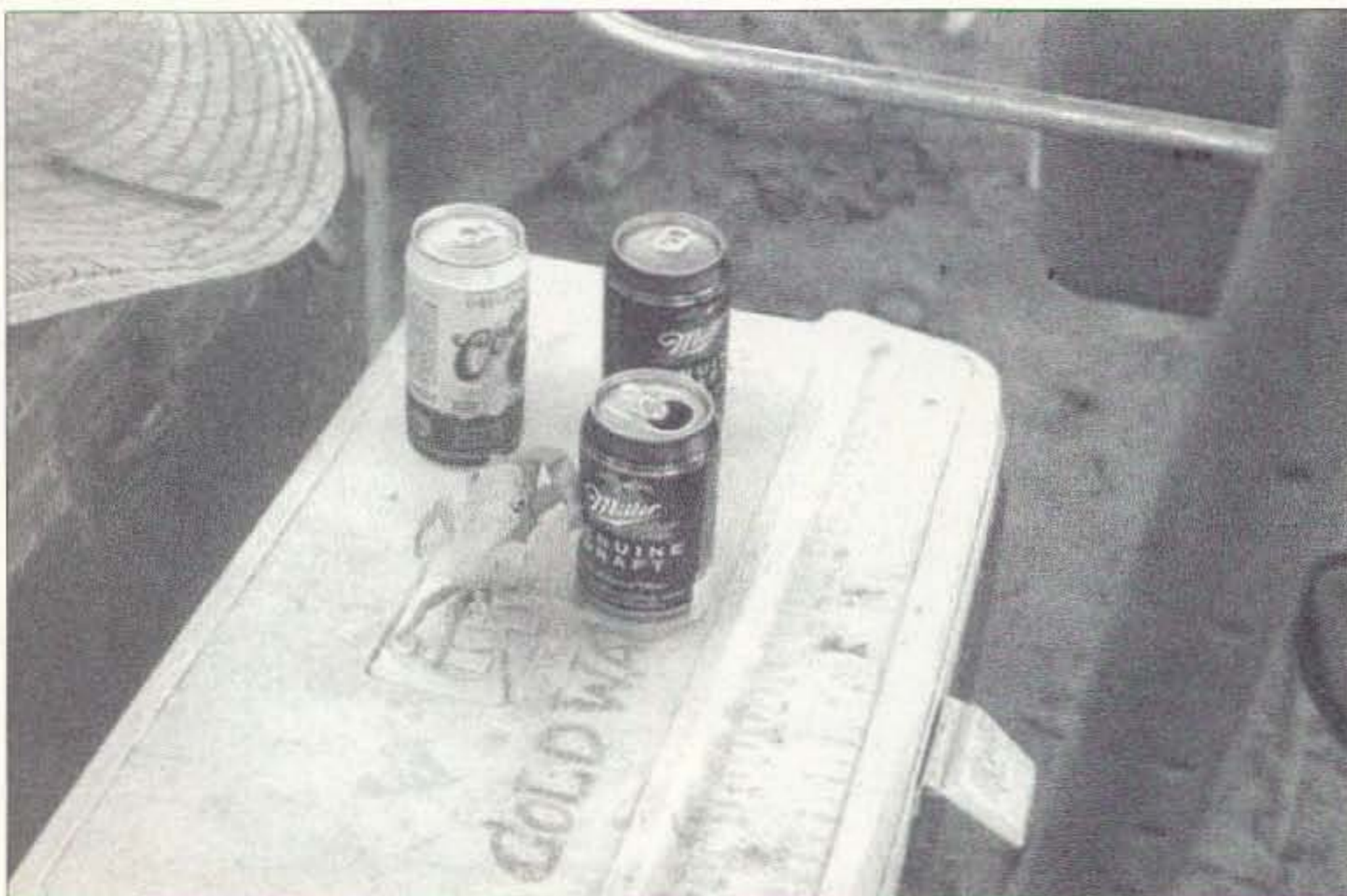

*Photo E. Miller time for one of the local inhabitants.*

they must be experienced to be believed. Visualize yourself standing in front of an open fire hydrant. For the next hour, the six of us endured periods of intense rain and near hurricane-force wind. The rain at times struck us so hard that the drops stung — we thought it must be hail! It was all we could do to hold on to the tent so it wouldn't blow away. What a welcome!

"Finally, at about 3:30 the clouds parted, the wind dropped and we were able to resume the landing operations. By dark, everyone was ashore, and about half our gear was piled up on the beach. Two campsites, about 1150 feet apart, had been selected, and we had set up two tents with cots for sleeping. At dark, about 7:00, we had our first

equipment failure. We had hauled one generator to the island, and when we fired it up, it ran about five minutes and died. We had four 5-kilowatt main generators and a smaller backup, so we had to use our 'backup' generator from the start. Everyone was exhausted, so we crashed early, with the plan of starting assembly of the camp and antennas at first light (about 5:30 a.m.). I have camped a lot, and under difficult conditions at times, and I must say that this was probably the worst night in my life. We were lying uncomfortably on army cots with no blankets or pillows. Many of us, including myself, had not gotten our personal gear onto the island, so we hadn't washed or changed into dry clothes. So I was wet,

uncomfortable and freezing cold all night as the wind was blowing briskly through the tents. Add to this all the crabs crawling about beneath the cots, (let your arm drop off the cot and within a few minutes they were nibbling on your fingers) and the constant honking of all the birds outside — Well, you get the picture. Few of us slept at all, and when I got up around 5:00, I found James, Mark, and a couple others already outside assembling an A3 beam in the gray light before sunrise! Before long, we were all up and busy. What an interesting experience it was trying to set up antennas and tents that morning! The birds are particularly active at sunrise, and we had to shout at each other to be heard over the cacophony of noise. The combination of the bright orange land crabs crawling around everywhere on the otherwise barren landscape added to the screeching of thousands of birds made an almost surreal setting. I kept asking myself, 'Is this really happening or am I dreaming?'

"To continue, by midafternoon we had tents, radios, antennas, and generators all assembled at both sites and were ready to go. We assembled about 4:00 p.m. at the SSB site where John was to make the symbolic first contact. He picked 20 meters, 14.195 as a starting point and whose melodious voice did we hear on that frequency but good old V31JP 'Joe Palooka' (K8JP) talking to none other than Pete NØFW. Now the irony of this is that Pete was one of the organizers of the 1992 trip and held the license FOØCI. So John broke in and put Pete in the log as the first QSO for FOØAAA, and V31JP was the second. And more ironic, on the 1992 trip after our first QSO, which was with a KL7, Joe K8JP broke in on us and was the second QSO for that Clipperton DXpedition as well! That guy just will not leave us alone! After those QSOs, which were logged at about 0015Z on March 2nd, the band exploded and John handed the mike to Eddie EA3NY, then covered his ears laughing as we all scattered to take up an operating position. Doug VE5RA took over the second SSB station, opening up on 12 meters where he made 677 QSOs on his first 3-hour shift. There was a mad rush down to the CW tent with James 9V1YC and Mark ON4WW running the fastest so that they could become the first operators on CW. Also, in the SSB tent, we set up the RTTY station, with Doug N6TQS doing all the operating, and a 6-meter station with Koji JK7TKE doing most of the work. Eventually, we set up a third CW station to give us an extra station for low band work at night.

"Here's the equipment list. SSB site,

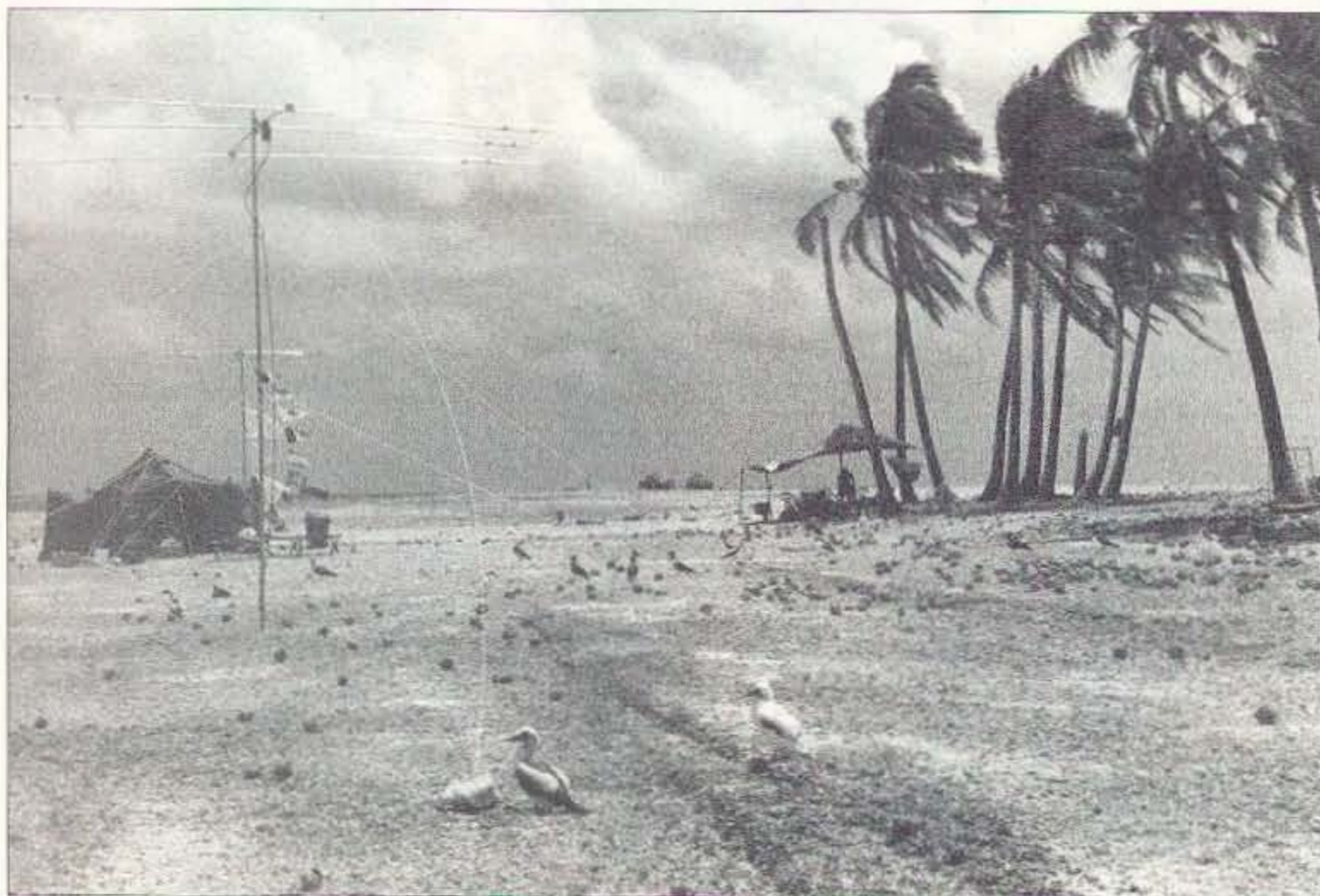

*Photo F. Another stormy day in Paradise.*





Photo G. We survived Clipperton Island.

radios: 4 Icom IC-756PROs (courtesy Icom), 2 for HF SSB, 1 for six meters, and 1 for RTTY. Antennas: 1 A3WS (courtesy Cushcraft), 1 A3S (courtesy Cushcraft), 1 Cushcraft MA5B minibeam used exclusively on RTTY (courtesy Cushcraft), 1 6m beam (courtesy M2), 1 Butternut HF9V, 1 K9AY inverted L for 75m. CW site, radios: 2 Icom IC-756PROs (courtesy Icom), 1 Kenwood TS-850. Antennas: 1 A3WS, 1 A3S, 1 Battle Creek Special used on 160m, 1 single HF2V for 40m (no 4 square) (courtesy WØGJ), 1 inverted L for 80m in coconut tree (courtesy ON4WW), 1 receiving antenna (like a combo K9AY, EWE, and Pennant, computer enhanced by K6SE), built by ON4WW.

"For the next several days, it seemed all we did was operate and sleep, operate and sleep, with an occasional meal thrown in. After spending the first two days on the island setting up with practically no sleep, all of us were very tired, so were hitting the sack every chance we got. I had the additional assignment of seeing that the generators were fueled up. So often in between operating shifts I was hauling gasoline between camps and feeding generators. James arranged shifts so we sometimes had two in a row, and I often ended up with one on CW and the second on SSB, usually late at night. So I would haul empty gasoline cans over to the SSB site, where I filled them and hauled them back when my shift was over. This was particularly challenging at night with only a small flashlight for

guidance, as it was kind of tricky finding a smooth path for the cart. The route had to cross both soft sand and rough coral, not to mention dodging dozens of sleeping birds. Several times I was stumbling along half asleep and ran into one which rudely jolted me wide awake with loud squawking and a peck on the leg! ...

"We had to depart the island the afternoon of Wednesday, March 8th. We anticipated it would be slow and difficult to get off the island, so in order to be sure we could get away in time, we started breaking camp at daybreak on the 7th. We intended to remove all but the bare essentials necessary to keep some stations going into the next day. Everything but the tents, antennas, and one generator were taken down and hauled to the landing site. This took until midafternoon, so FOØAAA was off the air for about ten hours that day. That night I think everyone felt both sad that it was over and happy that we were leaving. I suspect if given a choice, we all would have voted to stay two or three more days. That night, we decided to shut down for good at 10:00 a.m., or 1800Z, the next day. As the hour approached, we all gathered around the SSB tent to watch John make the last QSO. As for the first QSO he chose 20 meters, but had to tune around a bit to find a clear spot, ending up near the IOTA hangout of 14,260, where he found a station on Revilla Gigedo Island — XF4LWY. A fitting end perhaps, one rare island talking to another we thought, as John broke a pileup for the last FOØAAA contact.

"At 9:00 a.m., the *Shogun* pulled up to its berth at Fisherman's Landing. Now the adventure really was over. All that remained was to unload the ship, and then shake hands one more time as each member departed for home.

"We were all tired and glad it was all over. The excitement, the victories, and hardships were all behind us. Then came the question that is always asked — Was it worth it? With over 75,000 QSOs in the log, the answer has to be a resounding YES. We went there to put Clipperton Island in as many hams' logs as possible. I think we succeeded. Now, on to the next one ... 73, Mike N9NS."

That is only a sample of the great story that Mike has left for all of us on the Web page. I hope that you point your browser in that direction; and if you happened to work them, perhaps you will reflect a bit about what it must have been like at the other end of all the clamoring that was spread about the ham bands during this fine DXpedition. So hats off to Eddie EA3NY, Mike N9NS, Willy HB9AHL, Jim N9TK, Koji JK7TKE, Charlie NØTT, Bob K7UEE, Mark ON4WW, Doug N6TQS, John N7CQQ, Jim 9V1YC, and everyone else who make this effort a successful one.

#### Pulling the big switch

My apologies to all for the misspelling of TXØDX in last month's column. I'll "ride heard" on the publisher a little harder next time.

So much for this month's offering. I look forward to hearing from all of you very soon, so ... 73 and good DX! 73

#### WANTED

Fun, easy-to-build projects for publication in 73.

For more info, write to:

Joyce Sawtelle,  
73 *Amateur Radio Today*,  
70 Hancock Road  
Peterborough NH 03458.

#### LOW PROFILE HF ANTENNAS THAT REALLY WORK!

"Work the World Without Working Up the Neighborhood"

### ISOTRON

BILAL COMPANY

Call for a FREE Catalog:

719/687-0650

137 Manchester Dr.  
Florissant, CO 80816

www.rayfield.net/isotron

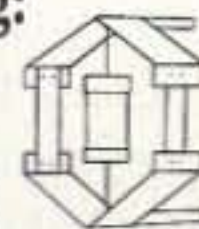
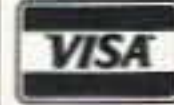

# NEW PRODUCTS



## Universal Super Catalog

Universal Radio has just come out with their newest catalog, which is cram-packed with good deals on everything

from ARS transceivers to connectors to books to SWL stuff to flashlights to ... well, you name it. 106 pages of fun and bargains would be a good way to describe it.

That's the good news. The bad news is that it has a \$2 cover price. BUT the really good news is that most catalogs like this that we've seen go for \$10 or more. AND the really, really good news is that it is FREE for the asking to 73 readers (well, to others as well, we suppose).

To order yours, contact Universal Radio, 6830 Americana Pkwy., Reynoldsburg OH 43068; (800) 431-3939; [www.universal-radio.com].



## Paddlette K-4 Iambic Keyer

Housed in a tiny black box (3/4 x 1-1/2 x 2 inches) and weighing just one ounce, the K-4 will operate for four years on its self-contained lithium coin cell. Basically, it generates strings of dits and dahs

in response to paddle strokes, as well as provides 12 keying options to the user: speed adjust, tune, paddle select, sidetone on/off, straight key mode, iambic mode A/B, beacon, enter message #1, enter message #2, play back message #1, play back message #2, and iambic keyer mode.

The TicK-4 CMOS keyer IC also includes nonvolatile memory for speed, mode, paddle select, and sidetone on/off. \$48.95 + \$2.25 s/h.

For further information, contact Paddlette Company, P.O. Box 6036, Edmonds WA 98026; (425) 743-1429; [bham379627@aol.com].



## Gordon West Updates

WB6NOA has announced the completion of his three new and up-to-date license manuals for Element 2 Technician Class, Element 3 General Class, and Element 4 Extra Class. Also new is his six-tape code cassette course, specifically recorded for the 5 wpm Element 1 exam.

The new Tech book, valid through June 30, 2003, covers all 394 questions, plus West's description of the correct answers. The General manual is 160 pages and valid through June 30, 2004; it includes a special 16-page pull-out section that focuses on recent changes in General licensing requirements. The Extra book is a whopping 240 pages and good through June 30, 2002; it contains all 676 questions in the exam pool.

For more information, contact Gordon West WB6NOA, Radio School, Inc., 2414 College Drive, Costa Mesa CA 92626; (714) 434-0666; (714) 549-5000 10-4 p.m.

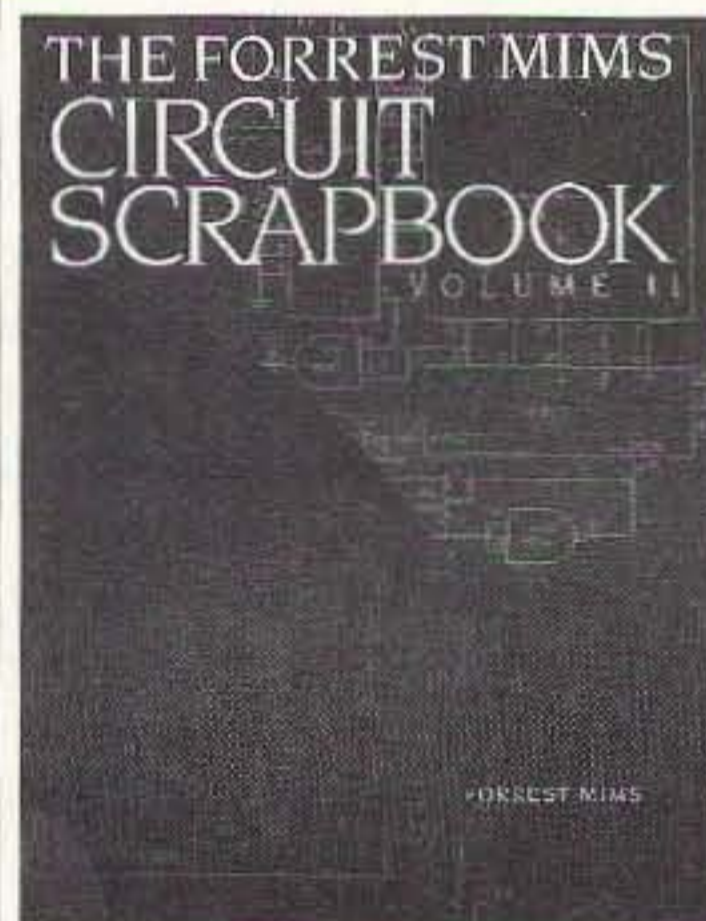

## Forrest Mims Circuit Scrapbook II

This is the second volume of the book mentioned in this space last month. It's a collection of some of Mims' best

work from Modern Electronics, showing how to build and experiment with: audio synthesizers, data loggers, fiber optic sensors, laser diode devices, MOSFET oscillators, piezo-electronics, power supplies, pulse generators, radio control systems, and much more.

Each circuit includes a schematic, detailed theory of operation, construction hints, and other useful information. \$24.95.

For further information, contact LLH Technology Publishing, 3578 Old Rail Road, Eagle Rock VA 24085; (540) 567-2000; fax (540) 567-2539; [carol@LLH-Publishing.com].

## New Hamcalc CD-ROM

Hamcalc Version 43 has just been released by its guru, VE3ERP. It contains many new programs and upgrades, compiled into a collection of over 250 painless math and design programs for radio amateurs and professionals. Most programs can be run in either metric or imperial/USA units. Contains much info not found in current amateur handbooks and literature, and is easy to use for nontechnical hobbyists.

For a free Hamcalc MS-DOS/Windows CD-ROM, send \$7 shipping and handling to George Murphy VE3ERP, 77 McKenzie St., Orillia ON L3V 6A6, Canada; [ve3erp@encode.com].

## WinCw by Electrosoft

Electrosoft has introduced a Windows-based Morse code sending program that works under Win 3.1, 95, and 98. The program offers a large type-ahead buffer (100 characters) with visual display; 10 preprogrammable F-key memories where you can store up to 100 characters each; a repeat message function with timer setting; adjustable sending speed from 5-99 wpm; sidetone on/off; tune transmitter on/off; send on serial port com1 or com2; and wired RS232 interface cable to connect your computer to your rig. \$25.

For more information or to order, contact Stephen Stuntz NØBF, Electrosoft, P.O. Box 1462, Loveland CO 80539; [n0bf@juno.com].

# ADVERTISERS' INDEX

R.S.#	page	R.S.#	page	R.S.#	page	R.S.#	page
• Alinco .....	CV2	• East Coast		86 MFJ Enterprises .....	15	• Radio Book Shop .....	42
• All Electronics Corp. ....	11	• Amateur Radio .....	13	• Michigan Radio .....	49	• Radio Book Shop .....	47
16 Astron Corporation .....	2	• E-Z Hang .....	35	160 Micro Computer Concepts	42	• Radio Book Shop .....	53
42 Bilal Company .....	47	193 GGTE .....	25	193 Morse Tutor Gold .....	25	• Radio Book Shop .....	57
56 Buckmaster Publishing ....	21	• Ham Mall .....	31	• Mouser Electronics .....	37	• Radio Book Shop .....	63
168 Buckmaster Publishing ....	26	• Hamtronics, Inc. ....	9	• MultiFAX .....	21	• Radio Book Shop .....	64
• COMET .....	33	• Heil Sound .....	25	• Omega Sales .....	53	34 Ramsey Electronics .....	3
99 Communication Concepts	31	42 Isotron .....	47	• Omega Sales .....	57	• RF Parts .....	53
• Communications Electronics	5	242 Jan Crystals .....	28	• Omega Sales .....	58	• Ross Distributing .....	28
10 Communications		• Kenwood		• Omega Sales .....	59	• Scrambling News .....	37
Specialists, Inc. ....	31	Communications .....	CV4	• Radcomm Radio .....	41	• Universal Radio .....	59
13 Doppler Systems .....	51	86 MFJ Enterprises .....	7	• Radio Book Shop .....	37	• Yaesu .....	CV3

When you buy products from these advertisers, please tell them that you saw their ads in 73.  
 Subscribe to 73 right now...call 800-274-7373 (9-5 Monday-Friday EST).

**WE SHIP WORLDWIDE**  
**Michigan Radio**  
 SALES SERVICE

Local & Tech 1-810-771-4711, Service 1-810-771-4712, Fax Service 1-810-771-6546

OPEN  
 TUES, WED, THUR 10-6  
 FRI 11-8  
 SAT 10-3  
 CLOSED SUN & MON



Terms do not include shipping. Price and availability subject to change without notice. Most orders shipped same day. COD's welcome (\$5.50 & shipping).

26014 Groesbeck, Warren, MI 48089  
**1-800-TRU-HAMM** (orders only)  
 (800-878-4266)

Now on the World Wide Web

<http://michiganradio.com>

E-mail [mirad@mich.com](mailto:mirad@mich.com)



TM-V7A

TH-D7A

TM-261

**KENWOOD**



TM-G707A



TS-570S

TS-870S



IC-746

**ICOM**



IC-W32A

IC-Q7A

IC-T8A



FT-2600M

FT-100



FT-847

**YAESU**

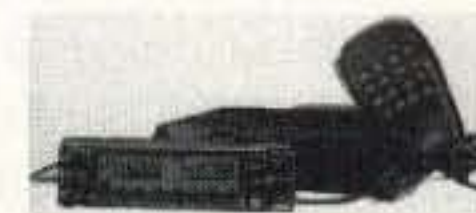

FT-8100R



VX-5R

FT-840

FT-50R

- Convert Excess Equipment to CASH • We buy good, clean, used equipment • Estate Sales

# Digital Satellite Communications

*Since the beginning of the year we have investigated what it takes to make contact via the "easysats" using portable, mobile, and home stations. With the launch of the largest, most powerful amateur-radio satellite, Phase 3D, only months away, it's time to take a look at basic digital satellite communications.*

Phase 3D carries a wide array of transponders for voice and CW, but it also has digital communications systems, as do a growing number of low-earth-orbit hamsats.

### Packet

Most hams think of packet radio when digital ham communications is mentioned. This is caused by the wide proliferation of inexpensive TNCs (terminal node controllers) that can be purchased from any ham dealer. Typical packet operation is accomplished by connecting the TNC to a PC and the mic and speaker connections of a two-meter FM transceiver. The data-communications speed is usually only 1200 baud. This can get rather tedious for those that have experienced high-speed Internet connectivity using DSL or cable modems. Why bother?

There is a constant search for useful packet-radio applications. Some of the more interesting uses have included packet E-mail, telemetry reporting, file transfer, DX clusters, satellite store-and-forward operations, and APRS.

### APRS

APRS (Automatic Packet Reporting System) was developed by Bob Bruninga WB4APR to track location data in near-real time. With a small GPS (Global Positioning System) receiver, and APRS software [<http://www.tapr.org>], the portable packet station can be set up to automatically send beacons containing latitude and longitude information and short messages. It's a quick and effective way to report the location of a car, boat, balloon, or the lead bike in a race.

Most APRS data is sent via digital repeaters, or digipeaters. A lot of this data finds its way to Internet sites that show maps of

station locations by callsign and type [<http://www.aprs.net>]. Special icons on the maps denote portable, stationary, and mobile units.

At the AMSAT 16th Space Symposium and Annual Meeting in October 1998, Bob WB4APR proposed TRACKNET, an AMSAT mobile satellite system. Bob suggested the use of current under-utilized 1200-baud packet hamsats for APRS digipeating. Some of the hamsats in Bob's plan included AMSAT-OSCAR-16, LUSAT-OSCAR-19, and ITAMSAT-OSCAR-26.

Due to the satellite hardware configuration, the mobile ground units would require minor TNC circuit modifications to transmit, but would not be able to monitor the satellite downlink. The uplink to these pacsats is Manchester-encoded two-meter FM, while the downlink requires 70-cm SSB reception, frequency tracking, and more interface electronics. A few stationary gateway stations would be set to collect downlink data and forward it to the Internet.

The system works, but there are not many participants. The tests through the packet system on *Mir* in early 1998 were more popular. The *Mir* system simply acted as a digipeater for APRS packets on a simplex, two-meter-FM frequency. No TNC or radio modifications were required. Any station that could transmit standard APRS packets could also monitor the activity via the *Mir* downlink.

### SUNSAT

SUNSAT-OSCAR-35 was launched on February 23, 1999, on a Boeing Delta II rocket from Vandenberg Air Force Base in California. SUNSAT is a relatively complex satellite designed and built at the University of Stellenbosch in South Africa. In

addition to many experiments and payloads for educational programs, this satellite carries a mix of voice and digital amateur-radio systems. The various frequency-agile transponders can be programmed to activate in either mode at specific times.

Bob WB4APR and Johann Lochner ZR1CBC, the SO-35 Control Operator, began a series of experiments earlier this year for packet tests over North America. Unlike the other pacsats, SO-35 typically operates at 9600 baud and can support packet digipeating without interrupting normal downlink data, like the images that SO-35's onboard cameras take. There were some coordination and scheduling glitches, but these tests were very preliminary. Announcements were only sent to those that subscribed to the "aprsat" remailer via [<http://www.tapr.org>]. For most of the tests, the downlink was on 145.825 MHz with a corresponding uplink of 436.290 MHz.

One goal of the tests was to determine the effectiveness of 9600-baud portable and mobile APRS stations using simple omnidirectional antennas and moderate power via satellite. Thanks to some new radios from Kenwood, the experiments were a success; they will provide direction for future tests, and perhaps an APRS hamsat.

### New radios

If you have seen any Kenwood advertisements in the last year, you have seen their dual-band HT, the TH-D7, and their new mobile dual-band transceiver, the TM-D700. Both radios can operate full-duplex crossband FM voice for satellite communications via AMRAD-OSCAR-27, UoSAT-OSCAR-14, and SO-35, and they can also be used for certain types of digital operation via satellite.

Both radios can be used for standard 1200- and 9600-baud packet and APRS on either two meters or 70 cm. The TM-D700 however, has a better TNC that can be configured for KISS mode (overrides standard TNC commands) thus allowing raw data reception, necessary for typical 9600-baud pacsat operation. Both rigs are constrained to a minimum 5-kHz tuning increment, but for FM work, this is sufficient for typical Doppler correction. The TH-D7 HT does not support full-duplex, crossband packet or full-duplex, crossband APRS. The TM-D700 will do KISS and full-duplex, crossband packet, but it will not easily support full-duplex, crossband APRS. Several stations though have successfully



**Photo A.** The Kenwood TH-D7 HT has built-in 1200 and 9600-baud packet with APRS support. A long dual-band antenna makes it useful for pacsat work or crossband voice operation.



**Photo B.** The Kenwood TM-D700 mobile radio can do stand-alone APRS transmission and reception from hamsats that support digipeat operation in addition to other pacsat and voice-satellite activity.

used either radio for the SO-35 tests. Bob WB4APR has devised several methods to circumvent the deficiencies.

If you are looking for a digital home satellite station for the current and future pacsats, rigs like the Yaesu FT-847 still provide the best core radio choice, but if your interests lean more toward portable and mobile activity, the new Kenwoods are worth a serious look. A TM-D700 can be configured to transmit and receive 9600-baud APRS data via satellite without any additional computers, TNCs, or other gear. For tips on setting up a TM-D700 for pacsat work, refer to the material at [<http://web.usna.navy.mil/~bruninga/astars.html>]. Books on APRS can be found at [<http://www.arrl.org>].

Digital satellite communications are going to higher speeds and more complex formats.

The best way to get started is to try off-the-shelf radios, software, and TNCs that can get you on the air while at the same time providing insight for future experiments. 73

## TRANSMITTER LOCATION

New fixed site direction finders provide 2 degree accuracy, and include software for triangulation from a central control site. Mobile versions also available covering 50MHz to 1 GHz

**Doppler Systems Inc.**

PO Box 2780 Carefree, AZ 85377  
Tel: (480) 488-9755 Fax: (480) 488-1295  
[www.dopsys.com](http://www.dopsys.com)

European Marketing Director Denis Egan  
PO Box 2, Seaton, Devon EX12 2YS England  
Tel & Fax: 44 1297 62 56 90



## Inside MixW32

*I have seen several notes from hams on my PSK31 monitor that MixW32 was their program of choice. Some claimed it to be the best there is. Well, you never know until you try, so I downloaded the demo file.*

There are so many freebies out there already, it is difficult to make a hit with a shareware program unless it really works. And this program really works!

However (you know there will be a catch when I toss in that word), I started out a bit disenchanted. The very first impression was that it received and printed the warbling mode very well. Good so far, but how to transmit? There is no transmit "button" on the screen. I thought I had tried all the hot-key combinations, but I was to learn I missed one, albeit the one not likely to be used.

There was also another missing ingredient: no obvious pull-down Help file. I was lost. Did the folks who were selling this program feel a demo was something you only copied with? No — they are a whole lot smarter than that. This was merely the beginning of a "learning moment."

Next stop, I gathered up notes from the readme file and sent an E-mail to Jim WA2VOS with the appropriate questions. It didn't take long to find there are two ways to toggle the transmit mode. The easiest is to use the "Pause" key. Bingo. I was in business.

Incidentally, on the day I was readying this article for the mail, I ran across Jim on PSK and snapped the accompanying screen shot. It had to happen — the conditions were such that the S-meters on either end were seldom moving. Of course, that again demonstrates the nearly unbelievable capability of PSK31 to get through where "mere mortal modes" fail so miserably. (See Fig. 1.)

With the help of keyboard dexterity, I made a RTTY contact and got back a very good report on signal quality. I didn't tell you this program had more than one mode, did I? More about that later. And I hadn't made any real changes in setting the audio drive since using the last soundcard program. MixW32 just plugged and played.

Next, it was time to give the PSK31 a try. Same group of problems here as with RTTY. There seemed to be no macros available, so CQ was manual as well as BTU turnovers, plus I sorely miss it when I don't have an operating PTT circuit. Well, I have gotten used to that as I try different programs.

It was E-mail time again. The program was obviously a winner in the quality of sent and decoded signals. Now I wanted to know how to get the rest of it working. Back to the E-mail. Jim solved most of the problems by sending the help file, which I printed immediately. There was all the information I ever wanted, including how to pop up the help files. How could I be so dumb? A very normal Alt+H is all that is necessary.

In the process of problem-solving, Jim had forwarded my E-mail request to the author, Nick UT2UZ, and he wrote back that my cable hookup for Logger would work just fine if I entered the correct information into the "Setup" screen. Here again, I had missed. Nick also uses an Icom 735 and he made sure all the rest of us could use the same radio by use of a few choices in pull-down menus in the Setup.

Once I started following directions it all fell into place. There are over 30 definable macros. I used four. I am easy to please. The CQ macro is edited separately with its own hot-key screen. It is self-repeating, and the interval between calls can be edited on the same screen. CQ is initiated by Alt+A. The oft-used macros would be initiated by simply pressing the function keys. Then there are other combinations when you wish to make a more complex set of macros.

After using the program for a week or two, I became pretty familiar with its ability to "grab" calls and allow the macros to use them. That is, when I want to return a station's CQ, usually the call is ready and the exchange automatically includes that

call when I press the function key for the macro. If not, you could say the program senses confusion and asks what call to insert, and generally suggests the last one it recorded. Makes it very easy once you are used to it.

The first few contacts (before help file) were made by tuning with a waterfall display that seemed to tax my patience. That was a negative I wasn't certain I could live with for very long. Then I found the program provides a choice of three tuning indicators. The one I prefer shows two spectral lines and (I think) is a great improvement over the waterfall. (See Fig. 1.)

Back to other modes. You recall I mentioned RTTY. You can tell when a ham who enjoys RTTY has written the software. This program utilizes the same AFC and NET tuning/tracking for RTTY as it does for PSK31. In other words, the soundcard will follow any drift it detects in the received signal, and then, when you switch to transmit, you are "zero-beat" with the other station.

Nick made it easy for you to switch between normal and reverse tones with a button. You can work RTTY without having to think your way through every move. This is what is referred to in the modern vernacular as intuitive.

It also does CW as well as any program I have tried and better than many. Copying CW with most software includes decoding in your head in order not to miss the important parts. I didn't listen to CW for a long while, but what I saw was impressive. It sends okay, but that is a little less problem. Anyway, a CW QSO looks to be as simple as cabling up and going for it. Cabling is the same as for the other modes.

The surprise to me was packet. I tuned to one of the HF packet frequencies, poked the packet button, and surprise me! It copied a sample of HF packet. The program sends

and receives packet with no complex manipulative extra software or modems. Pretty fantastic!

Then I saw a little button on the screen amongst the other "click-to-play" icons that is labeled Pactor. This was just too good to be true. However, it only does the "Listen" mode in Pactor, but it does that just like it does everything else with AFC and prints on the screen what it hears. Sometimes it looks perfect. Other times it looks like the typical Listen mode in that the signal isn't good enough to decode without numerous resend packets.

There is another mode, MTTY, that I have not tried as of this writing, but, even though it is experimental and only works with this software at both ends, I have heard favorable comments. Just a little added feature, all at the same price. Speaking of price, the cost of the registered package is about \$50 if you will accept it via download. On disk, there is another \$10, and this includes a printed documentation.

And you get more yet. The program includes a logging module that you can hold accountable for various awards. It works a little differently than other such programs,

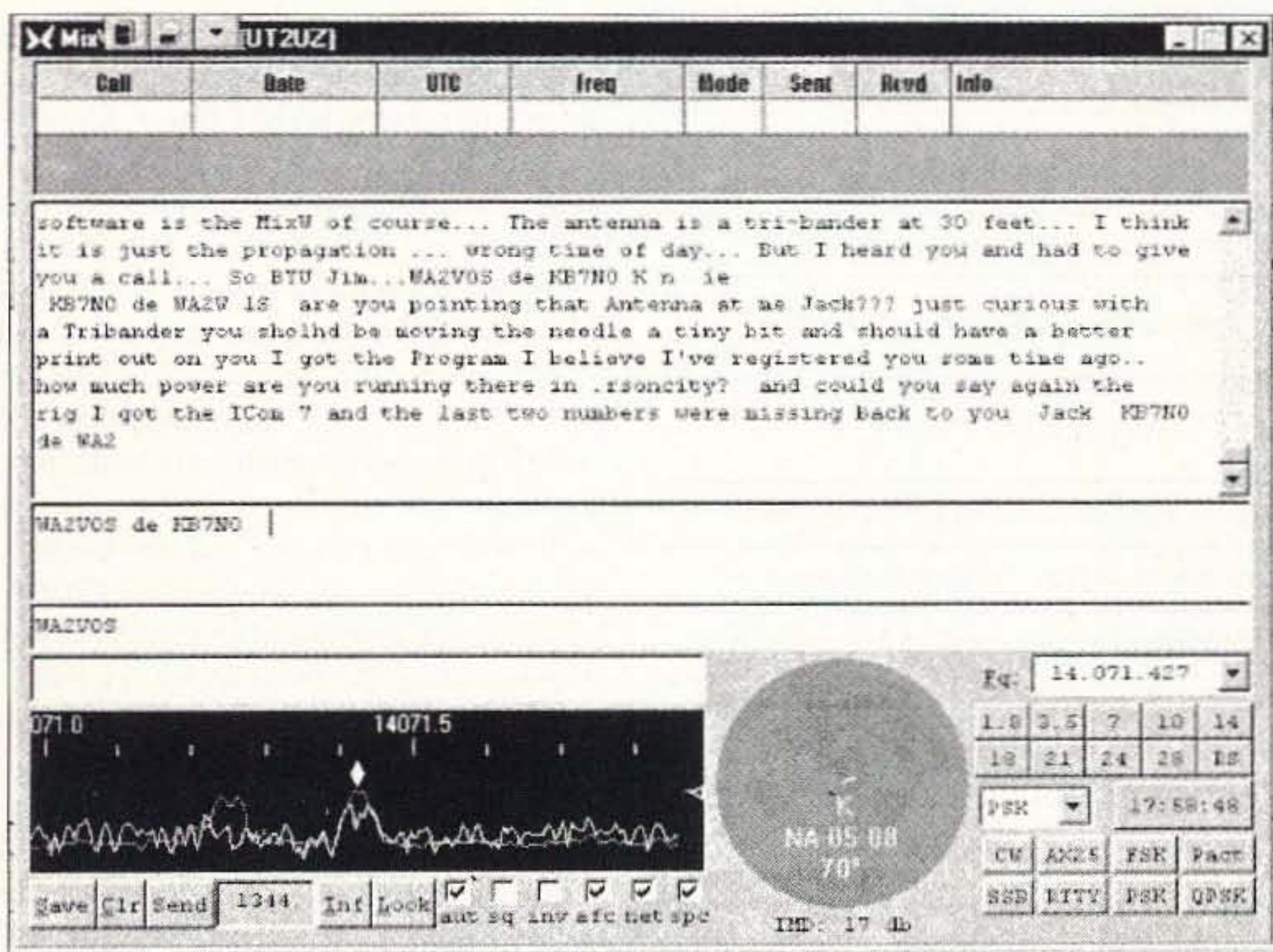

**Fig. 1. Screenshot.** As luck would have it, I found Jim WA2VOS on PSK31 the day I was readying to send this to the magazine. Conditions were at low tide. The copy at his end was worse, but with no wiggles on the S-meter, this is what it looked like. Several unique features of the program include a selectable tuning display. You can use the familiar waterfall or two other options. I opted for the spectral display. It takes a bit to get used to, but it works very well. Note the diamond above the depression between two humps. You can carefully tune your rig to center the diamond, or simply click in the depression and you are right on. There are two traces. If the magazine print allows, you can see a light colored hump above the depression. When the tuning knob is not being twisted, you can use the various humps across the display to locate other signals. The world display to the right gives the beam pointing automatically calculated by the program. The buttons on the right give some idea of the capabilities of the program. (See text for details.) There are several screens. At the top, below the title boxes, are the automated log entries. When you click the "Save" in the lower left, they will fill with the info from the current QSO, and editing is allowed. Below that, the large area is obviously for sent and received text. The next text area is the transmit buffer screen. Type-ahead is allowed. The callsigns displayed are from a macro I use that picks up the other station's call and adds mine. One function key and I have the start of the text for my return. Then I can type ahead while he is transmitting and dump it on him when he turns it over. Makes me look like a typist. The screen below that is where the program had "grabbed" the call during a CQ. From there, my macros can use the call for calling, BTU phrases, etc. The blank line can be automatically or manually entered with log information before you click the Save. This is an unregistered download, so you can see it is possible to thoroughly evaluate the program before you spring with the bucks.

### Back Issues

of

73 Magazine

Only \$5.00 Each!

Call 800-274-7373

### The New Pools!

Examination Test  
Questions & Answers

The exact questions, multiple choices and answers for the Technician Class, General Class, and Extra Class operator's license.



Only  
\$9.95  
Plus \$3.50 S&H

Omega Sales

P.O. Box 376

Jaffrey, NH 03452

800-467-7237



### From MILLIWATTS to KILOWATTS™



RF PARTS HAS IT!

Complete inventory for servicing  
Amateur, Marine, and Commercial  
Communications Equipment.

- Transmitting Tubes & Sockets
- RF Power Transistors
- VHF/UHF RF Power Modules
- Low Noise RF FET's
- Bird Electronics Wattmeters
- Doorknob Capacitors
- Chokes • Broadband Transformers

Se Habla Español • We Export

Visit our Web Site for latest  
Catalog pricing and Specials:  
<http://www.rfparts.com>

ORDERS ONLY  
1-800-RF-PARTS • 1-800-737-2787

ORDER LINE • TECH HELP • DELIVERY INFO.  
760-744-0700

FAX 760-744-1943 TOLL-FREE FAX 888-744-1943

E-MAIL: [rfp@rfparts.com](mailto:rfp@rfparts.com)



**RF PARTS**

435 SOUTH PACIFIC STREET  
SAN MARCOS, CA 92069

and that is because the author wanted to do it his own *fast and easy way*.

After I got MixW32 fairly well under my belt, I made contact over the air with other users. It was interesting to see their reactions to the program. Their experiences mirrored my own to one extent or another. The demo program, which is the first thing most of us see, is lacking in basic instruction. I think most of what I refer to as *new-user-angst* could be alleviated by letting the secret out that the answers to most questions can be found with some study of the built-in help

file (Alt+H, for anyone who forgot). This is a program well worth a try. The demo is available at [[http://tav.kiev.ua/~nick/my\\_ham\\_soft.htm](http://tav.kiev.ua/~nick/my_ham_soft.htm)].

In other news. Very likely, by the time this column is in print, the new-age PSK31 program from Bob Furzer will be in a lot of computers. Bob has decided to separate the logging program from the PSK31 program, so there will be Logger and Zakanaka (no, I don't know why, but it is the name of the standalone PSK31 software) as separate programs.

This transition looked as though it might have stalled for a time, as new help files were having to be written, and volunteer writers were at a premium (rare as hen's teeth). On the air, however, I overheard one ham say that he was writing help files for the new program and I conversed with another ham who was also doing some of the volunteer work.

I saw a screenshot of the new program on the Web, but that will surely all change by the time this hits print. So, if you can't find it with a search engine, let me know. I will probably have the correct URL if I keep my ear to the ground.

The Icom 756PRO found its way to the hinterlands of Carson City and it makes some real differences. The main reason for the purchase is the DSP IF filters. The second and top reason is the wife let me do it. Couldn't have happened otherwise. More on this new piece of furniture at a later date.

The point I wish to make at the time is that once I got down to the nitty-gritty and followed the setup on the radio to ensure that it would speak to the computer, and made a few minor adjustments to the program, a whole new era of communication is about to spring forth. I can turn the dial, and the readout on the Logger program follows just like one would expect. So, I will stop degrading the program for not listening. It simply needed more tuneful music to listen to.

What it all boils down to is that some radios do and some don't cooperate as well as others. I really don't know how many are in each category and it is not worth compiling. You know if yours works. There are various interfaces available for most radios, as well as different software. You have to find what works for you.

Speaking of radio control, I ran across several items lately that may capture your imagination. While I was gathering information on Icom from their Web page, I ran across reference to control programs. Naturally, since the company is in the business of building the hardware, they have some software listed.

I have mentioned the problem of getting Logger to poll the Icom 735 for current frequency readouts. At the time, I was not in the market, but I checked to see what was working for the IC-735. Not much from the parent company, but there was a link I followed to a logging program with control capability. It is YPLOG by VE6YP. It can be viewed at [<http://www.nucleus.com/~field/Icom.html>]. It can be downloaded to experiment

Source for:	Web address (URL):
Soundcard program for PSK31, RTTY, more	<a href="http://tav.kiev.ua/~nick/my_ham_soft.htm">http://tav.kiev.ua/~nick/my_ham_soft.htm</a>
TrueTTY — Sound card RTTY w/ PSK31	<a href="http://www.dxsoft.com/mitrtty.htm">www.dxsoft.com/mitrtty.htm</a>
Pasokon SSTV programs & hardware	<a href="http://www.ultranet.com/~sstv/lite.html">www.ultranet.com/~sstv/lite.html</a>
PSK31 — Free — orig. PSK31 — also Logger	<a href="http://aintel.bi.ehu.es/psk31.html">http://aintel.bi.ehu.es/psk31.html</a>
Site with links to PSK31 and Logger 6.12	<a href="http://www.mysite.com/k5fq">www.mysite.com/k5fq</a>
PSKGNR — Front end for PSK31	<a href="http://www.al-williams.com/wd5gnr/pskgnr.htm">www.al-williams.com/wd5gnr/pskgnr.htm</a>
Digipan — PSK31 — easy to use	<a href="http://members.home.com/hteller/digipan/">http://members.home.com/hteller/digipan/</a>
Scope program by Bob Furzer	<a href="http://www.chroniclenetworks.com/~dwm/Logger.htm">www.chroniclenetworks.com/~dwm/Logger.htm</a>
TAPR — Lots of info	<a href="http://www.tapr.org">www.tapr.org</a>
TNC to radio wiring help	<a href="http://freeweb.pdq.net/medcalf/ztx/">http://freeweb.pdq.net/medcalf/ztx/</a>
ChromaPIX and ChromaSound DSP software	<a href="http://www.siliconpixels.com">www.siliconpixels.com</a>
Timewave DSP & AEA products	<a href="http://www.timewave.com">www.timewave.com</a>
Auto tuner and other kits	<a href="http://www.ldgelectronics.com">www.ldgelectronics.com</a>
XPWare — TNC software with sample DL	<a href="http://www.goodnet.com/~gjohnson/">www.goodnet.com/~gjohnson/</a>
RCKRtty Windows program with free DL	<a href="http://home.t-online.de/home/dl4rck/">http://home.t-online.de/home/dl4rck/</a> [use lowercase DL4RCK]
HF serial modem plans & RTTY & Pactor	<a href="http://home.att.net/~k7sz/">http://home.att.net/~k7sz/</a>
SV2AGW free Win95 programs	<a href="http://www.forthnet.gr/sv2agw/">www.forthnet.gr/sv2agw/</a>
Source for BayPac BP-2M & APRS	<a href="http://www.tigertronics.com/">www.tigertronics.com/</a>
BayCom — German site	<a href="http://www.baycom.de/">www.baycom.de/</a>
BayCom 1.5 and Manual.zip in English	<a href="http://www.cs.wvu.edu/~acm/gopher/Software/baycom/">www.cs.wvu.edu/~acm/gopher/Software/baycom/</a>
N1RCT site — excellent RTTY ref.	<a href="http://www.megalink.net/~n1rct/">http://www.megalink.net/~n1rct/</a>
Int'l Visual Communication Assn. — nonprofit org. dedicated to SSTV	<a href="http://www.mindspring.com/~sstv/">www.mindspring.com/~sstv/</a>
Creative Services Software	<a href="http://www.cssincorp.com">www.cssincorp.com</a>
Hellschreiber & MT63	<a href="http://www.freeweb.org/varie/ninopo/iz8bly/index.htm">www.freeweb.org/varie/ninopo/iz8bly/index.htm</a>

Table 1. The "goodies" list.



# The MFJ Cub QRP Transceiver

*Over the last several years, the QRP community sure has seen a slew of new QRP transceivers. Gone are the days of crystal control and direct conversion receivers. Today, we have cutting edge technology that would have been unimaginable just a few years ago. But sometimes simple can at times be better. And, you just can't get things any more simple than the MFJ Cub QRP transceiver.*

The MFJ Cub is a very small QRP transceiver. It's a monobander, so you need to pick a band you want your MFJ Cub on. You can get an MFJ Cub for the 80, 40, 30, 20, 15, and 17 meter band. The MFJ Cub is a CW-only rig. It is a superhet-design receiver with VFO frequency control, and will produce up to 2 watts of RF at 13.8 volts. On 15 meters, you'll see about one watt of RF into the antenna. The MFJ Cub is not protected against high SWR. It's built around a single PC board, which is double-sided with solder mask and silk-screened with component placements.

What sets the MFJ Cub apart from the rest of the QRP rigs on the market is in the construction of the rig. The MFJ Cub is a kit, but 90 percent of it is already assembled. The reason why it's assembled? With the exception of the parts for the tuned circuits, the majority of the rig uses surface-mounted parts. In fact, the entire transceiver comes fully assembled. You only have to add on the necessary parts for the band you want to operate. In a nutshell, you assemble all the through-hole components in the MFJ Cub rig. MFJ packages the Cub with two

different parts bags. One contains the generic components such as the jacks, PA final, and other larger components. The other bag contains the parts used in the tuned circuits.

The MFJ Cub is based on a very popular NE602 design. There are three SA602s inside the rig. One is used as the receiver mixer, a second for the transmit mixer, and the third for the product detector and BFO. The audio output is supplied by an LM386 audio IC. Three crystals form a very selective filter for the receiver.

The MFJ Cub has several slick features. For one, it's protected from reverse polarity by a diode across the power source, and an internal PC fuse. If you hook the MFJ Cub up backwards, you pop the fused trace on the PC board, but you won't cook any of the surface-mount components. Also, it has electronic T/R switching for thumpless audio when switching between transmit and receive. The sidetone is also very clear and crisp.

### Putting the MFJ Cub together

Really, this is not a hard kit to assemble. In fact, you can build one in about one to two hours. Most of the time required for

assembly is spent on stuffing the frequency-dependent parts. The parts are small, and you'll need to slow down so that you don't put a wrong part in the wrong hole. You have to wind and mount several toroids, too.

The instruction manual is very clear. It used the usual step-by-step assembly method. Most of

the book deals with the various bands the MFJ Cub can be assembled on. Make sure you highlight the section you're working on, as it's easy to get misled if you start on one page, lose your place, and pick up somewhere else.

While you're working on the kit, it's kind of off slick to see all those surface-mounted parts just sitting there. I would guess that MFJ's automatic surface-mount machine could assemble a PC board in a matter of seconds!

The next step in getting your MFJ Cub to work is doing the alignment. This is not difficult, and does not require the use of expensive test equipment. In fact, you can align the MFJ Cub with nothing more than a dummy load, a QRP wattmeter, and a communications receiver. During alignment, you set the BFO frequency and the receiver

*Continued on page 59*



Photo A. The MFJ Cub.

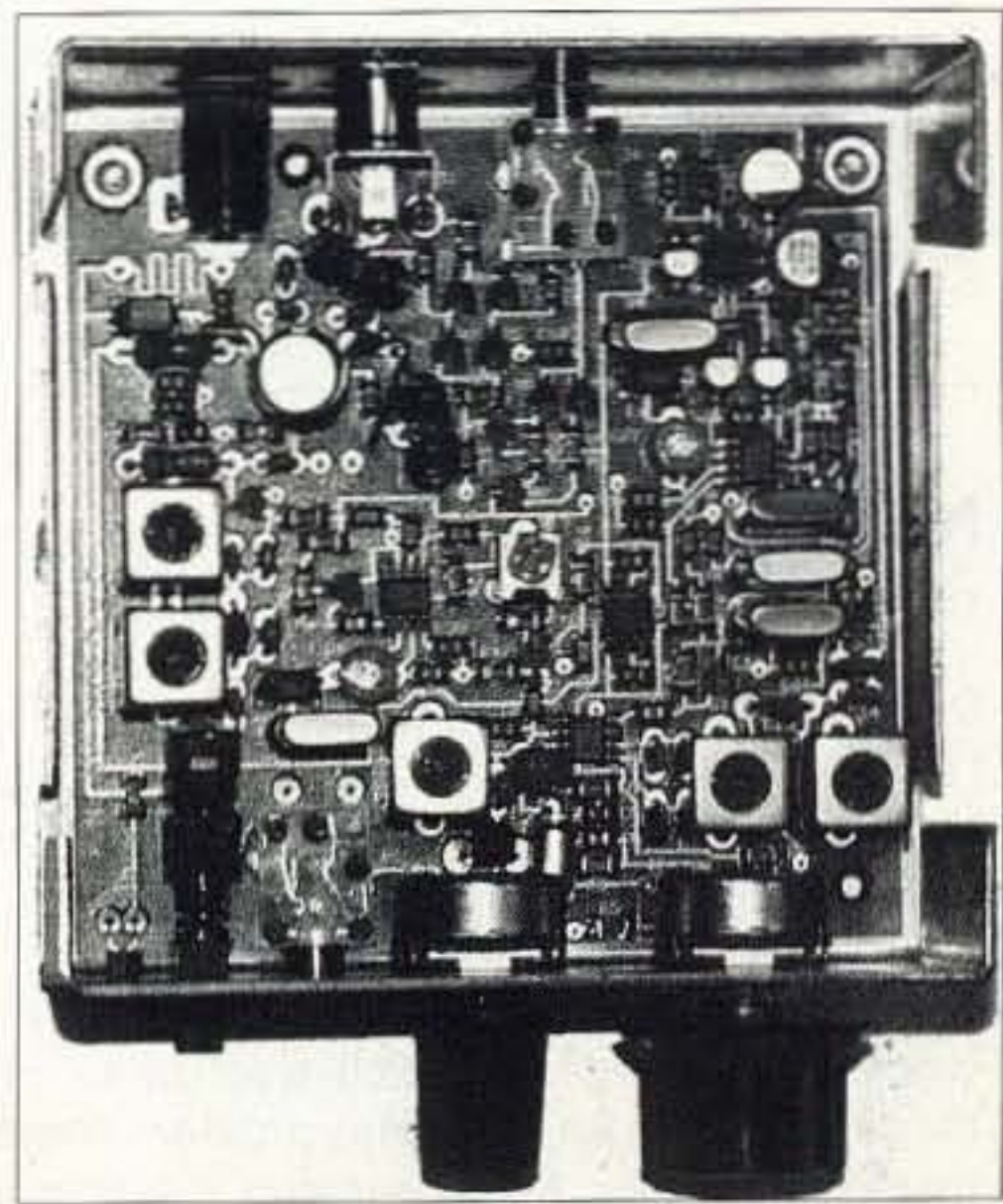

Photo B. Inside view.

## Get Your Motor Runnin' ...

*In this image supplied by NCG Company, the Comet CA-UHV antenna struts its stuff.*

This is the second generation of multi-band HF-UHF antennas by Comet. The CA-HV was the original model for HF-2m use, with the CA-UHV for HF-70cm. This new one is a 6m/2m/70cm triband antenna that is easily upgraded by attaching either one or two HF coils to the top and side. Adding more than two coils is possible, but the antenna becomes top-heavy when mobile.

The CA-UHV offers the modern ham several distinct advantages in mobile operation:

- Compact design for three, four, or five (or more) bands.

- Easy mounting via a standard trunk, door, or hatch mount. No drilling, welding, or special brackets are needed. Here we see the RS-730 mount and CK-3M5 deluxe coax cable assembly.

- Fold-over hinge allows for easy garage entry. A threaded collar securely holds the antenna upright while in motion but unscrews to use the hinge.

- The Comet CF-706A duplexer can combine two connectors (1.3–57 MHz and 75–550 MHz) into a single connector when using a single antenna.

- List price: \$149.95.

So, even if you don't have a 1999 Dodge Ram pickup in the Southern California sun as shown here, you can still go big-time mobiling with this Comet antenna that's great for *any* vehicle *anywhere*.

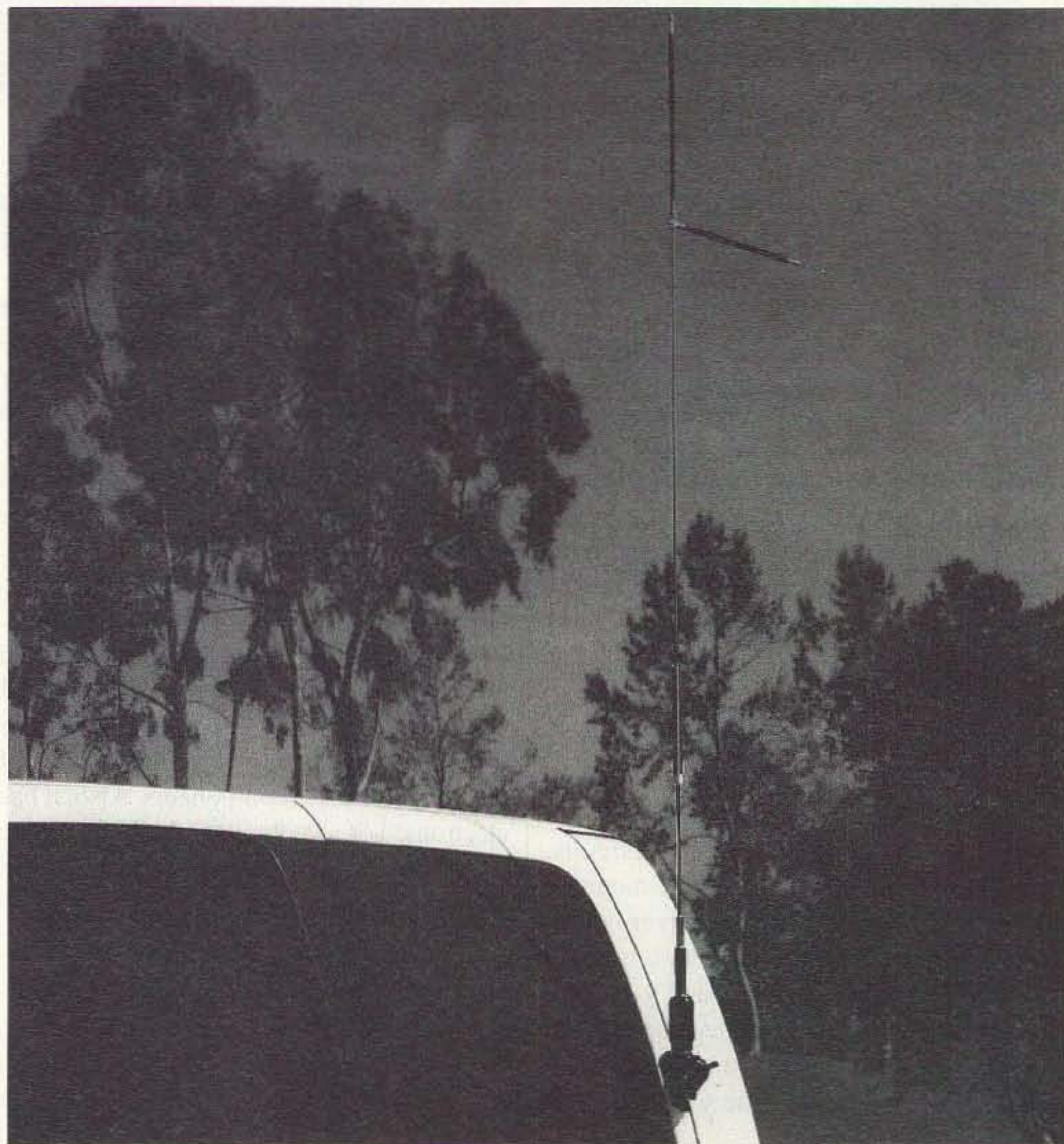

### NEVER SAY DIE

*continued from page 4*

in 20 minutes to pass the 5 wpm test. My "cheat" system has been used successfully by thousands of Techs and Novices. Learning the code quickly doesn't take a high IQ; it's just a matter of memory, not brains.

My business is also up for my \$5 five-word-per-minute tape which teaches all of the characters in an hour, plus provides some practice exercises. Each character is sent at a 13 wpm speed, allowing you to get familiar

with the sound of the character at the higher speed. For the truly dedicated, I have a 6 wpm practice tape (also \$5) which is fiendishly designed to be so maddening that you'll virtually snore through any VE code test.

To my surprise, the demand for my 13 and 20 wpm tapes has increased instead of died. More and more Techs, heading for the sun-spot-high-fertilized HF bands, are learning the code so they can have fun, not because the government and the ARRL has forced them to. Particularly if you're going to have a ball with QRP, you're going to want to be

able to handle 20 wpm and get in there with the little boys, having a ball with one to ten watts and talking to anyone anywhere in the world.

Until the FCC, followed by the rest of the world, I expect, defies the ARRL again and expands the HF phone bands, there'll be acres of wide open space for QRPCW contacts. With today's selective receivers, there's room for ten to twenty CW contacts for every phone QSO. Of course, if someone were to come

*Continued on page 61*

## The Universal Loop

*continued from page 13*

the 4mm plug pin ends, where they are securely soldered. Two small insulated blocks are next Super-Glued between loop and loop chassis, as shown, to prevent the loop "whipping."

The loop can now be tested, as previously described, and should effectively cover approximately 11 MHz–40 MHz.

It may be of interest to note that a replica loop was "lashed up" using lengths cut from wire clotheshangers. Contrary to what the textbooks tell us about the preferred use of copper or brass (over ferrous materials), there was no discernible difference in performance, apart from a small shift in frequency range!

### General observations

1. The question of the use of a preamplifier between loop and RX now arises. I used high-gain souped-up receiving equipment. A preamplifier overloads this equipment, producing intermodulation. However, in those cases where a preamplifier is needed, there are many published simple designs for wideband preamplifiers. Also, they can be purchased at reasonable prices.

2. The loop design is such that experimenters' individual designs and ideas can be made and fitted to a loop plug-in chassis. With this in mind, a range of conventional, and fat, ferrite loops have been shown, together with a spiral and square loop. Obviously this leaves the enthusiast with plenty of scope for individual ideas and designs.

3. The total frequency range is shown as 55 kHz–40 MHz. The LF end was fixed to incorporate the UK Rugby MSF 60 kHz Time & Frequency Standard station, which comes in very loud and clear. A similar station in the USA is WWVB in Denver, Colorado, which also uses 60 kHz. The frequency range could be further lowered by addition of extra capacity across the LF Loop (Fig. 7).

### Useful addresses

Maplin MPS  
P.O. Box 777  
Rayleigh, Essex SS6 8LU

United Kingdom  
tel.: 011-44-01702 5540000  
fax: 011-44-01702 554001

Amidon Associates  
3122 Alpine Avenue  
Santa Ana CA 92799  
USA  
tel.: (714) 850-4660

Antique Electronic Supply  
6221 S. Maple Ave.  
Tempe AZ 85283  
USA  
tel.: (480) 820-5411  
fax: (480) 820-4643

## Return of the Amazin' Hall Tree Vertical

*continued from page 19*

surrounding objects cannot be expected to operate as well as a full-size one in free space. Lately, sunspot activity has made 40 meters quite erratic and noisy at times.

This has made it difficult to collect much data on this antenna's performance. It has been used surrounded by trees in my front yard, too. Still, using 10 watts QRP on CW and 100 watts on phone, I have been able to make several contacts over 500 miles distant. The usual report was between 5/5 and 5/8.

Please give this easy antenna a try, and let me know how you make out!

Reprints  
of  
73 Magazine articles  
Only \$3.00 Each!  
Call 800-274-7373

## The Hybrid Vee

*continued from page 23*

extension. This becomes the basis for one of the antenna tuning elements.

Note: This tuning tee is NOT required unless the entire 20-meter band is to be covered, and is not required at all for the 17-meter band. If used, the upright tee can also be used to attach one end of the antenna wire. If not, the antenna wire is directly fastened to the end of the PVC pipe extension as shown in Fig. 1.

The basic antenna wire is #12 AWG THNN insulated electrical wire, available from your local hardware store.

The slanted leg of the inverted vee portion of the antenna is attached to the one end of the tee at the top of the mast, leaving a "pigtail" of wire for soldering to the shield braid of the coax feedline. (Note: The inner conductor of the coax feedline will be soldered to the top end of the vertical wire

*Continued on page 58*



A perfect travelling companion. The Mapbook contains locations of hundreds upon hundreds of open repeaters throughout the U.S., Canada and Mexico. These detailed maps show all highways and major cities in each state. If you travel anywhere in the United States, this Mapbook will be the best investment you ever made!

\$9.95

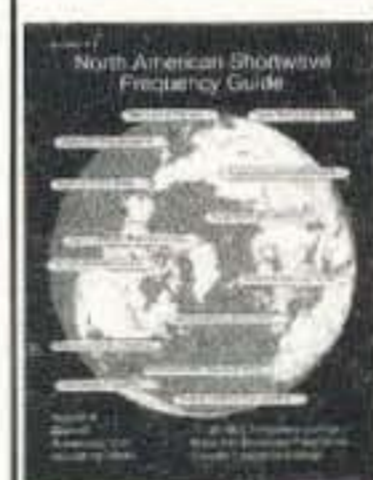

New in this third edition book are world frequency maps to help you tune into a specific country, anywhere in the world. The new quick country guide will help you tune in almost any time of the day or night.

\$19.95

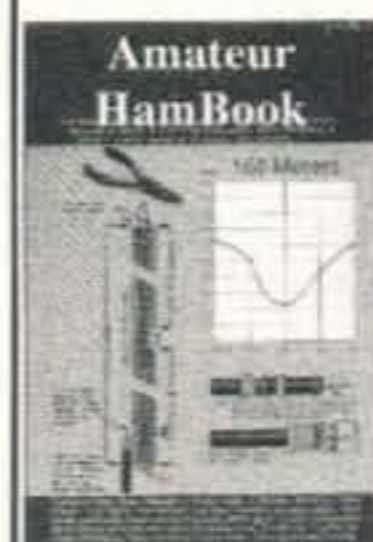

A true cornucopia of technical information for ham radio. Not only will you find the theoretical aspects, you will find real practical information presented in a no nonsense form. Equipment & Log Sheets, Charts, Tables showing: worldwide call signs, world times, shortwave listening frequencies, coax losses, CTCSS details, conversions, construction plans, emergency information, etc.

133 pages. \$14.95

Send check or money order plus \$3.50 shipping & handling to:

Omega Sales  
P.O. Box 376  
Jaffrey, NH 03452  
1-800-467-7237

## The Hybrid Vee

*continued from page 57*

element, which is attached to the other end of the Tee at the top of the mast).

Drill a small hole in each end of the tee, passing the wire through the hole, and loop it around for mechanical strength before soldering it to the shield braid.

If you intend to use 100 watts or less output power to this antenna, then RG-58 C/M coaxial cable is inexpensive and suitable for the feedline.

The (approximately 50-ohm) impedance of the coaxial feedline is sufficiently close to that of the antenna so that a matching transformer is not required. Also, a slight imbalance between unbalanced feedline and the balanced feedpoint of the antenna is considered to be satisfactory, so no balun was used, but the purist who wishes to remove any unwanted radiation from the coax shield, and who wishes a symmetrical pattern of radiation, may construct a simple 1:1 current balun consisting of ferrite beads, slipped over and taped to the coax at the antenna attachment end. OR, a simple six-turn coil of RG-58 C/M taped together into a six-inch-diameter loop and placed at the antenna feedpoint may be used as a 1:1 balun instead.

Attach the bottom end of the sloping antenna wire to the PVC pipe with a hose clamp if a tee is not used for holding the tuning element (17 meters,

e.g.). Otherwise, drill a hole and use the same method as used for attaching the top end of the wire.

Dimensions: For 20 meters, the sloping wire is cut to a length of 16.5 feet (sixteen feet, six inches) and the vertical leg is cut to approximately 14.5 feet (fourteen feet, six inches). The reason for the shorter vertical element is that a telescoping whip (surplus or used TV-type "rabbit ear") is used for final tuning adjustments to desired frequency. Rabbit ears for this antenna were obtained from a local TV repair shop.

### Making the tuning stubs

Mount a short length of 3/4"-diameter PVC tubing into the center leg of a 3/4" tee, and attach it to the mast opposite the boom arm by drilling it for a U-bolt. Position the tee upright. Then, drive a short piece of wood dowel, of a diameter to tightly fit, into the tee. Drill the dowel to accept the large end of the telescoping "rabbit ear," and slip the rabbit ear into the hole in the dowel, leaving an inch or two exposed at the bottom. Solder the bottom end of the vertical antenna wire to the rabbit ear. Now you have easy adjustment of the antenna frequency.

A similar tee at the boom end, complete with wooden dowel and rabbit ear, allows adjustment of each wire separately. In most cases this allows a perfect 1:1 SWR at the desired operating

tacted ham that I was trying out an experimental antenna and wanted a report, whether good, bad, or indifferent.

I used my Kenwood TS-440 and TS-450 transceivers for both transmitting and receiving, and the 20-meter and 17-meter antennas I built according to the drawings and description here. The 17-meter antenna is only 12 feet from apex to ground and the 20-meter antenna apex is at 17 feet above ground.

With no more than 100 watts of power output, I contacted SSB stations in Argentina, Brazil, Chile, and other South American countries, as well as France, Germany, Italy, Macedonia, Russia, Slovenia, and Spain. All gave me very readable, and sometimes very generous, signal strength reports.

The Taylor Hybrid is a simple, inexpensive antenna that almost anyone can build with locally available materials, for use in a limited space. The hybrid can be rotated easily for best signal reception and transmission from your location to desired areas of the world.

I believe the vertical element has added a substantial improvement to the already versatile Taylor Vee. Try one and see if you agree. 73

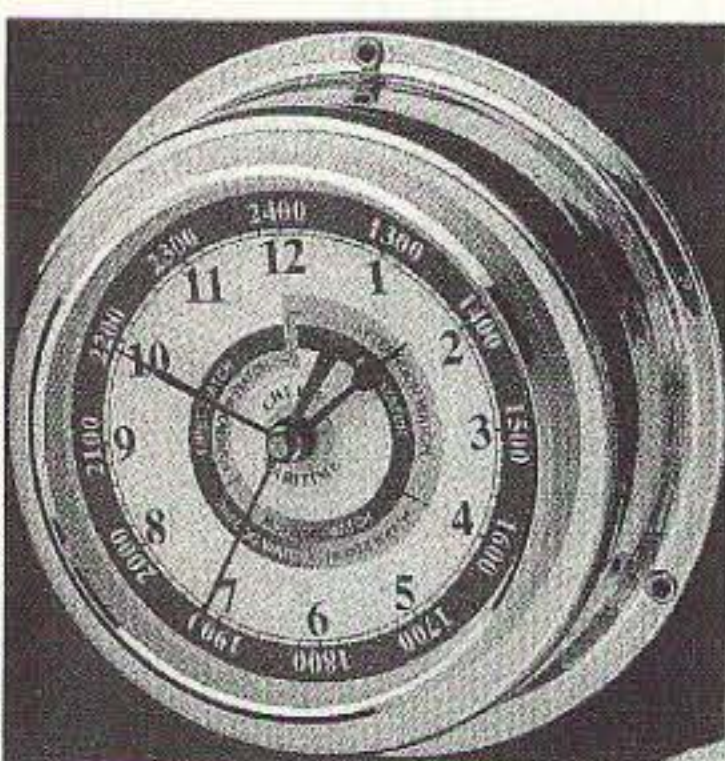

### Chelsea Clock

Clockmakers since 1897  
The choice of The Coast  
Guard Foundation.

Quartz Clock  
4" Dial

Beautifully hand-polished.  
Stamped brass case and  
bezel.  
Curved glass crystal.  
Wall or bulkhead mounting.  
Made so well they last from  
generation to generation!  
Order this month and save  
\$20!

**Your price \$75**

**Omega Sales**

**P.O. Box 376**

**Jaffrey NH 03452**

**1-800-467-7237**

frequency, and also totally eliminates the need for removing and replacing the antenna itself for wire trimming.

### Results

I have found that practical on-the-air QSOs have been most rewarding. I have requested honest reports from stations in the USA and from DX stations. In each case, I told the con-

## The Rocky Road to a Great Radio Club

*continued from page 32*

contacted by E-mail at: [WA2VNT/7@ece.arizona.edu].

The Conejo Valley Amateur Radio Club home page is located at: [http://www.cvarc.org/].

The Amateur Radio Newline home page is located at: [http://www.arnewline.org].

The Tucson Amateur Packet Radio home page is located at: [http://www.tapr.org].

The Radio Society of Tucson home page is located at [http://www.hamsrus.com/rst/rst.html].

The Tucson Computer Society home page is located at [http://www.aztcs.org/index.html].

A historical and tribute Web site dedicated to WABC Musicradio 77 of the 1950s through 1970s is located at

[http://www.musicradio77.com]. If you love radio, have the latest RealAudio player installed on your computer and be prepared to spend days perusing this site. 73

## ABOVE & BEYOND

*continued from page 40*

of the pipe, should be centered about the prime circular focus spot of the Fresnel lens. Cut the lens out carefully, using this center spot as the lens's exact center point of reference to the outer diameter.

Well, that's the full system description on the transmit side of the house. That should give you time to acquire components to construct your version of this system. Next month, I will cover the receiver system in detail, after some engineering still being finalized on a replacement for the synthesizer.

Of all of the components used in this project, the synthesizer (that we used) is the most expensive and does not have to be copied in your system. Any source of RF at some frequency, be it in the 2 meter amateur band or commercial upper VHF band (150 to 174 MHz), is usable.

We just had the synths on hand and used them for 2 meter HT operation — the synth is not mandatory. We haven't tried them, but there is no reason that a simple clock oscillator TTL module at another frequency couldn't be used or a simple crystal-controlled LO be constructed. This is a junk box decision on this project, so put the junk box to use here.

What I am thinking about for a minimum circuit is either a simple TTL clock oscillator running a frequency in the 2 meter band or one-half that frequency. If a clock oscillator is found that is one-half frequency, say, anything from 72 MHz to 74 MHz would still provide 2 meter usage. This oscillator would probably be injected into an MMIC amplifier, using it as a frequency harmonic doubling for LO mixer injection. I will be giving this a try, to see if I can design a suitable simple LO source to replace the synth we used.

Well, that's it for this month. Next month, in the column I plan to finish up the project with the receiver circuitry, more photos of the system, mount, and other construction details. 73

A clear conscience is usually the sign of a bad memory.

## THE DIGITAL PORT

*continued from page 54*

with, and you may just find something you like.

Then, to go along with this, I received an E-mail from another reader who found that I dropped the ball on another listing a few months back. After I was unable to produce the original Web site location for a small Icom program, I sent along info on the YPLOG. He went into the search mode himself, came back to me, and pointed toward another control program available from a French author. I took a look, but unfortunately, my vocabulary is French-challenged and I could only guess at the features. So, for now, you are stuck with the stuff I can understand and explain.

If you have questions or comments about this column, E-mail me [jheller@sierra.net] I will gladly share what I know or find a resource for you. For now, 73, Jack KB7NO. 73

## QRP

*continued from page 55*

bandpass filter. You'll set the transmit offset and transmitter bandpass as well. The final step is setting the output power. I found that all the adjustments were easy to make, and everything quickly fell into place.

### Putting the MFJ Cub on the air

There's very little you have to do to get the MFJ Cub on the air. In fact, all you have to do is supply it with a suitable power source and an antenna. Plug in your headphones and attach your resonate antenna. Operation of the MFJ Cub is as simple as humanly possible. You can either tune around looking for stations calling CQ, or get bold and send out one yourself. When you key the rig, it switches over instantly, and you just key away.

Of course, it's always at the end of one of these columns where I have to say that my first contact was with some faraway land. But, just as the last screw was tightened down, I heard a W3 calling CQ on 10.107 MHz. With clip lead in hand, I sent my call. Whoa! Back he came. I had a ten-minute QSO with this guy as I keyed in the CW with a clip lead. The MFJ Cub works like gangbusters! The MFJ Cub is a great little rig to have on your operating table. It's small, you can hold it in one hand, and it has enough humph to get the job done. The superhet design is sensitive and well-behaved. All and all, I think the MFJ Cub is

one of the best values around for a kit-based QRP transceiver.

The MFJ Cub is available from MFJ, or you can contact any of the many dealers around the country to order one for yourself. You'll love its assembly as well as its operation. 73

## The Gordon West Study Guides

Examination Test  
Questions & Answers  
for General Class and Extra Class  
with explanations of the answers



General Class  
\$12.95  
Plus \$3.50 S&H



Extra Class  
\$14.95  
Plus \$3.50 S&H

### Omega Sales

P.O. Box 376

Jaffrey, NH 03452

800-467-7237



## Shortwave Receivers Past & Present

Communications Receivers 1942-1997



- New 3<sup>rd</sup> Ed.
- 108 Chapters
- 472 Pages
- 840 Photos
- Printed 03/98
- Covers 1942 to 1997.
- 770 Receivers
- 660 Variants
- Includes 98 U.S. and Intl. manufacturers
- Only \$24.95

This huge 472 page Third Edition includes over 770 shortwave and amateur communications receivers made from 1942 to 1997. Here is everything you need to know as a radio collector or informed receiver buyer. Entry information includes: receiver type, date sold, photograph, size & weight, features, reviews, specifications, new & used values, variants, value rating and availability. Ninety eight worldwide manufacturers are represented. 840 Photos. Become an instant receiver expert!



### Universal Radio

6830 Americana Pkwy.  
Reynoldsburg, OH 43068

◆ Orders: 800 431-3939

◆ Info: 614 866-4267

www.universal-radio.com

## Sudden Surprises

*The summer months of June, July, and August are not particularly favorable for HF communication — even as we approach the peak of Sunspot Cycle 23 — due to over activation of the ionosphere, which creates absorption of HF signals during the midday hours.*

However, in the late afternoon and evening, the E and F layers return to more or less normal conditions for up to several hours, and the propagation of HF signals improves again.

In spite of this excessive summertime absorption and fading on the HF bands, VHF bands often become quite active for DXing, so, when HF activity seems poor, listen for good propagation on ten, six, and two meters.

As you can see from the calendar, propagation conditions are either Poor (P) or trending through Fair (F). Therefore, your best days for DXing appear to be the 7th through 11th, and again the 24th through the 31st, when Good (G) or Good-to-Fair or Fair-to-Good conditions prevail.

There will be sudden surprises that are not predictable this far (three months) in advance of publication. They include solar flares, disappearing filaments, coronal holes,

and other solar activity associated with sunspots that affect propagation. These so-called SIDs (Sudden Ionospheric Disturbances) result from disruption of the earth's magnetic field, and can spoil your day.

### Band-by-band summary

#### 10 and 12 meters

Good daytime DX

on transequatorial paths to North and South America, Africa, and the Pacific, is expected on (G)ood days, with signals peaking in strength during the local afternoon. Plenty of short skip to 1500 miles or more should occur on (G)ood days.

#### 15 and 17 meters

Good daytime DX to many parts of the world, with maximum signal strength occurring during the late afternoon hours. These bands usually close after dark. Daytime short skip is expected to 2,300 miles and beyond on (G)ood days.

#### 20 meters

Good DX conditions both day and night, with best signal strengths occurring after sunrise and again in the late afternoon and evening hours. You can also expect to hear strong signals in the west, northwest, and Pacific areas during hours of darkness. Daytime short skip beyond 2,000 miles is anticipated on most days.

#### 30 and 40 meters

Good DX to most parts of the world from our location is likely during night-time

EASTERN UNITED STATES TO:												
GMT:	00	02	04	06	08	10	12	14	16	18	20	22
ALASKA							17/20	15/17	15/17			
AUSTRALIA	12/15	12/15			12/15	20/40	12/15	20				
CENTRAL AM.	15/17	15/17	15/17	40	40		20	20			10/12	10/12
EUROPE		30/40	30/40					12/15	12/15	20/15	12/15	12/15
FAR EAST						20	15/17	20				
HAWAII	12/15	12/15	20/17	20/17	20/17		20					
INDIA	20				20	20						15/20
MID-EAST	20	20/40	20/40							12/15	12/15	12/15
RUSSIA/C.I.S.	17/20	17/20	17/20									17/20
S.E. ASIA	15/17	17/20										
SOUTH AFRICA		40/30		17/20				12/15	12/15			
SOUTH AM.	15	15	20	20							10/12	10/12
WEST COAST	15/17	20	20	30/40	30/40	30/40	30/40		10/12	10/12		15/17
CENTRAL UNITED STATES TO:												
ALASKA	15/17	17/20	17/20			30/40	17/20	17/20				
AUSTRALIA	15/17	15/17	17/20	17/20	20		20	20				
CENTRAL AM.	15/17	17/20	17/20	17/20	17/20		17/20	17/20	15/17	10/12	10/12	10/12
EUROPE	17/20	17/20	17/20									17/20
FAR EAST	15/17	17/20	17/20			30/40	17/20	17/20				
HAWAII	15/17	15/17	15/17	20	20/30	30/40		17/20				
INDIA	15/17	20					20					15/17
MID-EAST	17/20	17/20	20									
RUSSIA/C.I.S.	17/20	17/20	17/20	17/20						12/15	12/15	
S.E. ASIA	15/17		20	20				20				15/17
SOUTH AFRICA				20					15/17	20	20	
SOUTH AM.	10/12	15/17	30/40	30/40							10/12	10/12
WESTERN UNITED STATES TO:												
ALASKA	10/12	15/17		20	20	30/40		20				15/17
AUSTRALIA	10/12	15/17	15/17	20	20	20/30	30/40					
CENTRAL AM.	15/17	15/17	20/30	20/30	20/30	30/40				10/12	15/17	10/12
EUROPE	20						20		15/17	15/17	20	20
FAR EAST	10/12	15/17		20	20	30/40		20				15/17
HAWAII	10/12	17/20	20	30/40	30/40	30/40	20	20		15/17	15/17	15/17
INDIA	15/17							20	15/17			
MID-EAST	20	20							15/17		20	
RUSSIA/C.I.S.	20	20	20	20								20
S.E. ASIA	10/12							20	15/17	15/17		
SOUTH AFRICA			20	20					15/17			
SOUTH AM.	15/17	15/17	15/17	20	20	20/30						10/12
EAST COAST	10/12	10/12	15/17	20/30	30/40			20	10/12	10/12	20	20

July 2000						
SUN	MON	TUE	WED	THU	FRI	SAT
						1 P
2 P-F	3 F	4 F	5 F	6 F-G	7 G	8 G-F
9 F	10 F-G	11G-F	12 F	13 F	14 F	15 F
16 F	17 F	18 F-P	19 P	20 P-F	21 F-P	22 P
23 P-F	24 F-G	25 G	26 G	27 G	28 G-F	29 F
30 F-G	31 G					

hours, beginning at sunset and extending after sunrise. High static levels due to occasional thunderstorms along the path of propagation may be expected. Short skip between 500 and 1,000 miles can be expected on most days.

### 80 and 160 meters

Some weak DX openings may occur during darkness hours and around sunrise, but will often be masked by high noise levels due to thunderstorm static. Night-time skip between 200 and 2,000 miles may be expected, but daytime skip will be limited to about 200 miles. 73, W1XU/7. 73

### QRX

continued from page 6

- When all your friends got their hair cut at the kitchen table.
  - When nearly everyone's mom was at home when the kids got there.
  - When nobody owned a purebred dog.
  - When a dime was a decent allowance, and a quarter a huge bonus.
  - When you'd reach into a muddy gutter for a penny.
  - When girls neither dated nor kissed until late high school, if then.
  - When your mom wore nylons that came in two pieces.
  - When all your teachers wore either neckties or had their hair done, every day.
  - When Bible reading and prayer started every school day.
  - When you got your windshield cleaned, oil checked, and gas pumped, without asking, for free, every time. And you got trading stamps to boot!
  - When laundry detergent had free glasses, dishes or towels hidden inside the box.
  - When any parent could discipline any kid, or feed him, or use him to carry groceries, and nobody not even the kid, thought a thing of it.
  - When it was considered a great privilege to be taken out to dinner at a real restaurant with your parents.
  - When they threatened to keep kids back a grade if they failed — and they did!
  - When women were called, "Mrs. John Smith," instead of their own name.
- And finally ...
- When being sent to the principal's office was nothing compared to the fate that awaited a misbehaving student at home.

Thanks to the September 1999 ARNS Bulletin. 73

Bills travel through the mail at twice the speed of checks.

### NEVER SAY DIE

continued from page 56

along and re-invent John Costas K2EN's double sideband, where G.E.'s management did a world class job of dropping the ball, we'd be able to have five to ten or more DSB phone contacts using the same bandwidth as one SSB signal.

In the meanwhile, start putting together a QRP kit, buy a key, and let's see what you can rack up in DX contacts.

Oh, yes: Get me busy with my cassette duplicator, turning out more code tapes for you.

### Gun 'Em Down

The gun control crowd got the upper hand in Australia, resulting in about 650,000 guns being confiscated, at a cost of more than \$500 million. Now, a year later, the first crime statistics reports are in. Countrywide, homicides are up 3.2%, assaults are up 8.6%, armed robberies are up 44% (!). In the state of Victoria, homicides with guns are up 300%. And all this followed a 25-year steady decrease in armed robberies. There has also been a dramatic increase in break-ins and assaults of the elderly.

Well, it makes sense. Gun control laws only affect law-abiding citizens. The certainty that homes are not protected with guns is a license for criminals, who do have guns, to have a field day.

If you're interested in becoming an expert on the subject, with a host of solid statistics handy, you'll want to read John Lott's *More Guns, Less Crime*. It's \$23, published by the University of Chicago Press, 224 pages, 1998.

No, I'm not an NRA member, but the mobs screaming for gun control are ill-informed (a.k.a. ignorant), driven to reflexively demonstrate by dishonest politicians.

### Crushed Babies

Maybe you heard about the Consumer Product Safety Commission warning parents that babies should *never* be allowed to sleep on adult beds, daybeds or waterbeds since that exposes the child to a "potentially fatal hazard." It turns out that 64 out of the 3,880,894 babies born in 1997 died on adult beds. I'd say we're in more danger from the CPSC than from rolling over on our babies and killing them.

Oh, yes, most of the babies were crushed by drunk parents.

If you read some of the more reliable literature on how best to raise a baby, you'll find that you get a happier and more intelligent baby if it is allowed to be with the mother full time, at least for the first year.

Say, I wonder how much the CPSC is costing us? I hope you'll ask your congressman to find better work for the staff of that government agency.

### Illegal Rain Barrels

Crazy as it seems, the use of rain barrels is illegal in Colorado! If you think

I'm really exaggerating, take a look at [www.gazette.com] and hunt for "rain barrel."

It's illegal in Colorado to divert a natural water source for domestic use which, of course, has to include rain. The idea was to protect the water rights of the people downstream, but the law is the law.

### UNH News

I see where the unionized professors at the University of New Hampshire, about half of the 630-member faculty, voted to strike if they don't get raises over the next three years averaging over 5% per year. Considering that their salaries have increased by an average of 4.5% per year over the last eight years, this sure looks like another case of union bullying. That's almost a 150% salary raise they've had over the last eight years! Now they want *more!*

Here's a state run university that has not distinguished itself in any way I'm aware of, and I've been living full-time in New Hampshire for the last 38 years, where the teachers' union has seemingly gone berserk with power. I sure wish the NH Legislature would start holding some hearings so they could provide some guidance for the university. I'll bet the teaching staff could be pared down by half, with the students benefiting. I know the university could operate tuition-free, and without any additional funds from the state. I've outlined that approach in my past editorials and in my \$5 *Improving State Governments* book.

Further, and making a profit on the project, the university could make the curriculum far better fit the needs of its future alumni. I almost got Rensselaer to set up such a project, but the faculty, fearing (rightfully) that this would force them to make serious changes, was able to kill it.

If you want to get an idea of how bad our American university system is please read the book by George Roche, the 28-year now-ex-president of Hillsdale College, *The Fall of the Ivory Tower*. See the review on page 9 of my *Secret Guide to Wisdom*.

### Textbook Survey

As if it isn't bad enough that our school kids are forced to memorize stuff to pass tests, stuff which goes in one eye and out the other, leaving little permanent evidence of it's having ever been there, maybe you read the report in *Time* that a study done by the American Association for the Advancement of Science has reviewed the most used middle school science textbooks. Not one got a passing grade.

So here we have a situation where the bottom 20% of high school graduates go to ed schools, which Rita Kramer, in her *Ed School Follies* survey report showed were worse than jokes, and where a recent PBS report showed were often "teaching" subjects they didn't know. And now, to no great surprise, we find that the texts our kids are using

Continued on page 62

## NEVER SAY DIE

continued from page 61

are a bunch of crap. Is it any wonder that our kids are last in international surveys? The only category where our kids came in on top is in how good they feel about themselves.

No, throwing more money at the situation isn't going to improve it. It's the whole system that's screwed up. We don't need to move the deck chairs, we need to start from scratch and design a better public school system. And we have no shortage of examples of innovative schools that work.

### Audible

With the Web excitement over MP3 coding for music, and now Audible of Wayne NJ's software encoding audio for narrower bandwidth and faster throughput for their audio books over the Web, I'd sure like to see some articles for 73 explaining these technologies for the readers. And then, the next obvious step will be to start applying them to our transmissions. How much can we cut down digital audio voice bandwidth? Can we even cut down the bandwidth of video to where we might be able to send more than slow scan pictures on 20m?

### Capitalism

Socialism, communism, and fascism have all failed wherever tried. Capitalism works pretty well, but it has some serious weak points. The worst part of this is that I'm not much on just citing problems. I much prefer to discuss a problem and then propose a practical solution for it.

If you've kept up with my thoughts in these areas, you know I've griped about the horrendous cost of prisons, plus the fact that they are not what they claim to be and are named: correction facilities. My proposals in this field would seriously cut down on the number of prisoners we'd need to incarcerate by over 50%, cut the cost of their incarceration by about 90%, offer unlimited facilities, and actually would educate inmates to live more in peace with society.

Well, I won't go into the long list of social miseries and government wastes that I've discussed and offered creative solutions for.

But this capitalism business has me stumped. The system works well for small businesses. It works great for them. But, as soon as a business gets big, it tends to be a bully and the playing ground is no longer close to being level. Then, it gets even worse as their hired guns descend on Washington and the state capitals with their armies of lobbyists, drowning out the voices of both small business and the public in the ears of Congress and the administration. These bastards are running the country, and this whole democracy facade is a joke.

Heck, our country doesn't even issue its own money! A group of bankers got Congressional Democrats to give that plum away early one morning when no one was looking in 1913 and make it so the government has to

borrow money from these bankers and pay interest on it when it spends anything. And just to make sure that there wouldn't be any serious fuss about this highway robbery, the bankers organized the buying of the country's major newspapers and then the broadcasting media. There isn't going to be any whistle-blowing over this, because they own the whistles.

All this power pays off. Big time! But not for you or me.

J.P. Morgan said that no corporate head should make more than 20 times what his workers were paid. By 1980, the typical big company CEO was taking home about 40 times what his workers were. By 1990, it was up to 85 times! By 1998, according to a recent study, the big company CEOs pocketed an average of 419 times that of production workers.

Michael Eisner, the chairman and CEO of Disney, earned more than \$575 million in 1998, for example. Well, Disney made a lot of money, you say. Sure, but what about Linda Wachner, the chairman and CEO of Warnaco, which makes Calvin Klein jeans? The company lost \$32 million in 1977, but Linda got paid \$73.2 million in salary, bonus (!), and stock options. Well, their accountants and lawyers had to organize the packages for minimum tax liabilities, so the taxable income had to be kept as low as possible.

When the big get bigger, they do it by killing off the small guys, and then the big guys who aren't as big as they are. And that's easy when you hold most of the cards. If you have franchisees who have invested in stores you supply, all you have to do is cut off some key supplies, and suddenly they're company stores. If you are a manufacturer, you contract out work to smaller companies, starting with small orders. Then, when they've come to depend on you, you give them a huge order. They borrow to get the machines to fill the order. You cancel the order, and they're for sale for pennies on the dollar.

In the music industry (remember, I used to publish the largest music magazine in the country, so I know that industry), there are six major labels (five are foreign-owned) and several thousand small independent labels. The majors can (and do) crush and buy any indie label they want, like swatting a fly.

How many car companies are there? Steel companies? And so on. In TV, there are three major networks. And Fox.

And all of these big companies have expanded everywhere in the world. IDG, the computer publishing giant, publishes computer magazines in about 60 countries. Or is it 75 by now?

I don't view this situation any more favorably than I do a New World Order global police state. But I don't have any proposals for changing the situation, so I'll just wring my hands about it.

Democracy is a pretty good system — particularly as envisioned by our founding fathers and enshrined in the Constitution. But the basic idea that 51% of the people can tell the other 49% what to do doesn't sit well

with me. I doubt that you bothered to watch the Ken Burns PBS program about the opening of the West. But it was a grim reminder of how rotten Americans can be. We mercilessly killed the Indians by the thousands. Women and children, too. And we weren't much kinder to the Chinese and Mexicans who were attracted by the gold rush. We were just as nasty as the Nazis were to the Jews and gypsies, the Chinese Communists to the landowners, and so on, to the current slaughters in Yugoslavia, East Timor, Rwanda, and so on.

Any ideas?

### A Man Thing

Say, how come we don't have more women on our bands? Yes, of course I have a theory. Yes, it'll probably make them mad at me for saying it. Jeesh, there's a first!

Okay, let's get down to business on this one. What are the main ham interests? Rag chewing and DXing. I suppose I should have listed the making of totally brainfree contacts where nothing of the slightest interest is ever said as number one, but I didn't want to hold the mirror up to too many readers lest their steam fog it. So let's go with rag chewing and DXing.

DXing, with its pileups and the big clobbering the weak, is the radio version of a fist fight. The guy with the biggest rig and antenna usually wins. Women tend to be non-confrontational, so this radio battle royal isn't their cup of tea. Men fight and women compromise, the psychology texts tell us. Well, there's no way to compromise your way to contacting 350 countries.

So, how about rag chewing. Same problem, kinda. Men talk man talk and women talk woman talk. Different subjects, totally. Women are interested in children, clothes, shopping, and so on. Men are more interested in sex, technology, cars, sports, and telling off-color jokes.

Then we have the splinter groups on RTTY, slow scan, packet, the satellites, and so on. These are technology-heavy pursuits. Now, I've talked with hundreds of YL hams at hamfests (and even a few on the air), but in my 60 years of hamming, I've met just two YL hams that were comfortable talking technically. One was a lovely gal from Trinidad who worked at Bell Labs, and the other I hired as the editor of 73. Alas, she (a) married a wealthy ham and moved to Costa Rica, and (b) smoked, so she died many years before she should have.

Oh, I can tell the story now. Kayla, who had been president of the YLRL, had a hobby. Other than amateur radio, that is. She was intent on bedding as many of the ARRL HQ staff and directors as she could, and she ran up a truly impressive score. She even nailed Ken Sessions K6MVH, who later was a 73 editor. No, she didn't score with me!

But, as usual, I digress. I hope that helps explain why we don't hear that many female voices on our bands. It's the Mars vs. Venus thing.



# Wise Up!

Here are some of my books which can change your life (if you'll let 'em). If the idea of being healthy, wealthy and wise interests you, start reading. Yes, you can be all that, but only when you know the secrets which I've spent a lifetime uncovering.

.....Wayne

**The Bioelectrifier Handbook:** This explains how to build or buy (\$155) a little electrical gadget that can help clean the blood of any virus, microbe, parasite, fungus or yeast. The process was discovered by scientists at the Albert Einstein College of Medicine, quickly patented, and hushed up. It's curing AIDS, hepatitis C, and a bunch of other serious illnesses. The circuit can be built for under \$20 from the instructions in the book. \$10 (#01)

**The Secret Guide to Wisdom:** This is a review of around a hundred books that will help you change your life. No, I don't sell these books. They're on a wide range of subjects and will help to make you a very interesting person. Wait'll you see some of the gems you've missed reading. \$5 (#02)

**The Secret Guide to Wealth:** Just as with health, you'll find that you have been brainwashed by "the system" into a pattern of life that will keep you from ever making much money and having the freedom to travel and do what you want. I explain how anyone can get a dream job with no college, no résumé, and even without any experience. I explain how you can get someone to happily pay you to learn what you need to know to start your own business. \$5 (#03)

**The Secret Guide to Health:** Yes, there really is a secret to regaining your health and adding 30 to 60 years of healthy living to your life. The answer is simple, but it means making some difficult lifestyle changes. Will you be skiing the slopes of Aspen with me when you're 90 or doddering around a nursing home? Or pushing up daisies? No, I'm not selling any health products. \$5 (#04)

**My WWII Submarine Adventures:** Yes, I spent from 1943-1945 on a submarine, right in the middle of the war with Japan. We almost got sunk several times, and twice I was in the right place at the right time to save the boat. What's it really like to be depth charged? And what's the daily life aboard a submarine like? How about the Amelia Earhart inside story? If you're near Mobile, please visit the Drum. \$5 (#10)

**Wayne's Caribbean Adventures:** My super budget travel stories - where I

visit the hams and scuba dive most of the islands of the Caribbean. You'll love the special Liat fare which let me visit 11 countries in 21 days, diving all but one of the islands, Guadeloupe, where the hams kept me too busy with parties. \$5 (#12)

**Cold Fusion Overview:** This is both a brief history of cold fusion, which I predict will be one of the largest industries in the world in the 21st century, plus a simple explanation of how and why it works. This new field is going to generate a whole new bunch of billionaires, just as the personal computer industry did. \$5 (#20)

**Cold Fusion Journal:** They laughed when I predicted the PC industry growth in 1975. PCs are now the third largest industry in the world. The cold fusion ground floor is still wide open, but then that might mean giving up watching ball games. Sample: \$10 (#22).

**Julian Schwinger:** A Nobel laureate's talk about cold fusion—confirming its validity. \$2 (#24)

**Improving State Government:** Here are 24 ways that state governments can cut expenses enormously, while providing far better service. I explain how any government bureau or department can be gotten to cut it's expenses by at least 50% in three years and do it cooperatively and enthusiastically. I explain how, by applying a new technology, the state can make it possible to provide all needed services without having to levy any taxes at all! Read the book, run for your legislature, and let's get busy making this country work like its founders wanted it to. Don't leave this for "someone else" to do. \$5 (#30)

**Mankind's Extinction Predictions:** If any one of the experts who have written books predicting a soon-to-come catastrophe which will virtually wipe most of us out are right, we're in trouble. In this book I explain about the various disaster scenarios, like Nostradamus, who says the poles will soon shift (as they have several times in the past), wiping out 97% of mankind. Okay, so he's made a long string of past lucky guesses. The worst part of these predictions is the accuracy record of some of the experts. Will it be a pole shift, a new ice age, a massive solar flare, a comet or asteroid, a bioterrorist attack? I'm getting ready, how about you? \$5 (#31)

**Moondoggle:** After reading René's book, *NASA Mooned America*, I read everything I could find on our Moon landings. I watched the videos, looked carefully at the photos, read the astronaut's biographies, and talked with some of my readers who worked for NASA. This book cites 25 good reasons I believe the whole Apollo program had to have been faked. \$5 (#32)

**Classical Music Guide:** A list of 100 CDs which will provide you with an outstanding collection of the finest classical music ever written. This is

what you need to help you reduce stress. Classical music also raises youngster's IQs, helps plants grow faster, and will make you healthier. Just wait'll you hear some of Gotschalk's fabulous music! \$5 (#33)

**The Radar Coverup:** Is police radar dangerous? Ross Adey K6UI, a world authority, confirms the dangers of radio and magnetic fields. \$3 (#34)

**Three Gatto Talks:** A prize-winning teacher explains what's wrong with American schools and why our kids are not being educated. Why are Swedish youngsters, who start school at 7 years of age, leaving our kids in the dust? Our kids are intentionally being dumbed down by our school system—the least effective and most expensive in the world. \$5 (#35)

**Aspartame:** a.k.a. NutraSweet, the stuff in diet drinks, etc., can cause all kinds of serious health problems. Multiple sclerosis, for one. Read all about it, two pamphlets for a buck. (#38)

**One Hour CW:** Using this sneaky booklet even you can learn the Morse Code in one hour and pass that dumb 5wpm HF entry test. \$5 (#40)

**Code Tape (T5):** This tape will teach you the letters, numbers and punctuation you need to know if you are going on to learn the code at 13 or 20 wpm. \$5 (#41)

**Code Tape (T13):** Once you know the code for the letters (#41) you can go immediately to copying 13 wpm (using my system). This should only take a couple of days. \$5 (#42)

**Code Tape (T20):** Or, you can start right out at 20 wpm and master it in a weekend. \$5 (#43)

**Wayne Un-Dayton Talk:** This is a 90-minute tape of the talk I'd have given at the Dayton, if invited. \$5 (#50)

**Wayne Tampa Talk:** This is the talk I gave at the Tampa Global Sciences conference—where I cover amateur radio, cold fusion, health, books you should read, and so on. \$5 (#51)

**\$1 Million Sales Video:** The secret of how you can generate an extra million dollars in sales just by using PR. This will be one of the best investments you or your business will ever make. \$40 (#52)

## Reprints of My Editorials from 73.

Very few things in this world are as we've been taught, and as they appear. I blow the whistle on the scams around us, such as the health care, our school system, our money, the drug war, a college education, sugar, the food giants, our unhealthy food, fluorides, EMFs, NutraSweet, etc.

**1996 Editorials:** 120 pages, 100 choice editorials. \$10 (#72)

**1997 Editorials:** 148 fun-packed pages. 216 editorials. \$10 (#74)

**1998 Editorials:** 168 pages that'll give you lots of controversial things to talk about on the air. \$10 (#75)

**1999 Editorials:** 132 pages of ideas, book reviews, health, education, and anything else I think you ought to know about. \$10 (#76)

**2000 Editorials:** In the works.

**Silver Wire:** With two 3" pieces of heavy pure silver wire + three 9V batteries you can make a thousand dollars worth of silver colloid. What do you do with it? It does what the antibiotics do, but germs can't adapt to it. Use it to get rid of germs on food, for skin fungus, warts, and even to drink. Read some books on the uses of silver colloid, it's like magic. \$15 (#80)

**Wayne's Bell Saver Kit.** The cable and instructions enabling you to inexpensively tape Art Bell W6OBB's nightly 5-hr radio talk show. \$5 (#83)

**NH Reform Party Keynote Speech.** It wow'd 'em when I laid out plans for NH in 2020, with much better, yet lower cost schools, zero state taxes, far better health care, a more responsive state government, etc. \$1 (#85)

**Stuff I didn't write, but you need:**  
**NASA Mooned America:** René makes an air-tight case that NASA faked the Moon landings. This book will convince even you. \$25 (#90)

**Last Skeptic of Science:** This is René's book where he debunks a bunch of accepted scientific beliefs—such as the ice ages, the Earth being a magnet, the Moon causing the tides, and etc. \$25 (#91)

**Dark Moon:** 568 pages of carefully researched proof that the Apollo Moon landings were a hoax—a capping blow for René's skeptics. \$35 (#92)

## Radio Bookshop

Box 416, Hancock NH 03449

Name \_\_\_\_\_ Call \_\_\_\_\_

Address \_\_\_\_\_

City-State-Zip \_\_\_\_\_

Use the numbers in the brackets or copy page and mark the books you want. Add \$3 s/h per total order in US (\$5 priority mail), \$6Can, \$10 foreign.

Order total: US\$ \_\_\_\_\_ Phone (for CC orders) \_\_\_\_\_

MC/Visa for orders over \$10. # \_\_\_\_\_ Expire \_\_\_\_\_

www.waynegrain.com • phone orders: 603-525-4747 • fax: 603-588-3205 • w2nsd@aol.com

Yes! Put me down for a year of 73 for only \$25 (a steal). Canada US\$32. Foreign US\$44 by sea.

I'd like to get more romance into my dreary life so send me your How-To-Dance Videos catalog.

I need some industrial strength stress reduction so send me your Adventures In Music CD catalog

Allow 4 weeks for delivery except foreign, though we try to get most orders shipped in a day or two.

# Barter 'n' Buy

Turn your old ham and computer gear into cash now. Sure, you can wait for a hamfest to try and dump it, but you know you'll get a far more realistic price if you have it out where 100,000 active ham potential buyers can see it, rather than the few hundred local hams who come by a flea market table. Check your attic, garage, cellar and closet shelves and get cash for your ham and computer gear before it's too old to sell. You know you're not going to use it again, so why leave it for your widow to throw out? That stuff isn't getting any younger!

The 73 Flea Market, Barter 'n' Buy, costs you peanuts (almost)—comes to 35 cents a word for individual (noncommercial!) ads and \$1.00 a word for commercial ads. Don't plan on telling a long story. Use abbreviations, cram it in. But be honest. There are plenty of hams who love to fix things, so if it doesn't work, say so.

Make your list, count the words, including your call, address and phone number. Include a check or your credit card number and expiration. If you're placing a commercial ad, include an additional phone number, separate from your ad.

This is a monthly magazine, not a daily newspaper, so figure a couple months before the action starts; then be prepared. If you get too many calls, you priced it low. If you don't get many calls, too high.

So get busy. Blow the dust off, check everything out, make sure it still works right and maybe you can help make a ham newcomer or retired old timer happy with that rig you're not using now. Or you might get busy on your computer and put together a list of small gear/parts to send to those interested?

**Send your ads and payment to: 73 Magazine, Barter 'n' Buy, 70 Hancock Rd., Peterborough NH 03458 and get set for the phone calls.** The deadline for the October 2000 classified ad section is August 10, 2000.

**President Clinton** probably doesn't have a copy of *Tormet's Electronics Bench Reference* but you should. Check it out at [[www.ohio.net/~rtormet/index.htm](http://www.ohio.net/~rtormet/index.htm)]  
—over 100 pages of circuits, tables, RF design information, sources, etc. BNB530

**TELEGRAPH COLLECTOR'S PRICE GUIDE:** 250 pictures/prices. \$12 postpaid. **ARTIFAX BOOKS**, Box 88, Maynard MA 01754. Telegraph Museum: [<http://wltp.com>]. BNB113

**Great New Reference Manual** with over 100 pgs of P/S, transistor, radio, op-amp, antenna designs, coil winding tables, etc. See details at [[www.ohio.net/~rtormet/index.htm](http://www.ohio.net/~rtormet/index.htm)] or send check or M.O. for \$19.95 + \$2.00 P&H to RMT Engineering, 6863 Buffham Rd., Seville OH 44273. BNB202

**RF TRANSISTORS TUBES** 2SC2879, 2SC1971, 2SC1972, MRF247, MRF455, MB8719, 2SC1307, 2SC2029, MRF454, 2SC3133, 4CX250B, 12DQ6, 6KG6A, etc. **WESTGATE**, 1-800-213-4563. BNB6000

**QSL CARDS.** Basic Styles; Black and White and Color Picture Cards; Custom Printed. Send 2 stamps for samples and literature. **RAUM'S**, 8617 Orchard Rd., Coopersburg PA 18036. Phone or FAX (215) 679-7238. BNB519

**Cash for Collins:** Buy any Collins Equipment. **Leo KJ6HI**. Tel./FAX (310) 670-6969. [[radioleo@earthlink.net](mailto:radioleo@earthlink.net)]. BNB425

**Browse** our web site and check out the "Monthly Special." TDL Technology, Inc. [www.zianet.com/tdl](http://www.zianet.com/tdl). BNB500

**MAHLON LOOMIS, INVENTOR OF RADIO**, by Thomas Appleby (copyright 1967). Second printing available from **JOHAN K.V. SVANHOLM N3RF**, SVANHOLM RESEARCH LABORATORIES, P.O. Box 81, Washington DC 20044. Please send \$25.00 donation with \$5.00 for S&H. BNB420

**Ham Radio Repair**, Quality workmanship. All Brands, Fast Service. **Affordable Electronics**, 7110 E. Thomas Rd., Scottsdale, AZ 85251. Call 480-970-0963, or E-mail [HAM\\_SERVICE@AOL.COM](mailto:HAM_SERVICE@AOL.COM). BNB427

**METHOD TO LEARN MORSE CODE FAST AND WITHOUT HANGUPS** **Johan N3RF**. Send \$1.00 & SASE. SVANHOLM RESEARCH LABORATORIES, P.O. Box 81, Washington DC 20044 USA. BNB421

**ASTRON** power supply, brand-new w/warranty, RS20M \$99, RS35M \$145, RS50M \$209, RS70M \$249. **Web:** [[www.avenrade.com](http://www.avenrade.com)]. Call for other models. (626) 286-0118. BNB411

**HEATHKIT COMPANY** is selling photocopies of most Heathkit manuals. Only authorized source for copyright manuals. **Phone:** (616) 925-5899, 8-4 ET. BNB964

**"MORSE CODE DECIPHERED"** Simple, elegant, inexpensive, comprehensive, logical, easy! E-mail [[judlind@earthlink.net](mailto:judlind@earthlink.net)]. BNB428

**Electricity, Magnetism, Gravity, The Big Bang.** New explanation of basic forces of nature in this 91-page book covering early scientific theories and exploring latest controversial conclusions on their relationship to a unified field theory. To order, send check or money order for \$16.95 to: American Science Innovations, PO Box 155, Clarington OH 43915. Web site for other products [[http://www.asi\\_2000.com](http://www.asi_2000.com)]. BNB100

**COLLOIDAL SILVER GENERATOR!** Why buy a "box of batteries" for hundreds of dollars? Current regulated, AC powered, fully assembled with #12 AWG silver electrodes, \$74.50. Same, but DC powered, \$54.50. Add \$2.50 shipping. **Thomas Miller**, 962 Myers Parkway, Ashland OH 44805. BNB342

**COLD FUSION! - FUEL CELL! - ELECTRIC BI-CYCLE!** Each educational kit: (Basic - \$99.95, Deluxe - \$199.95, Information - \$9.95.) CATALOG - \$5.00. **ELECTRIC AUTOMOBILE BOOK** - \$19.95. **KAYLOR-KIT**, POB 1550ST, Boulder Creek CA 95006-1550. (831) 338-2300. BNB128

**TELEGRAPH KEYS AT DAYTON HAMFEST:** 500+ Civil War - Present. Bring Yours! History, Information, Appraisals, pretzels! Buying, Trading, Selling. **SPACE 2555**. <http://w1tp.com>. BNB705

**ROHN TOWERS HUGE DISCOUNTS CHECK PRICES AT HILLRADIO.NET** BNB600

**Wanted COLLINS S-LINE Pristine (RE)** 32S3-A, 75S3-C, 516F2, 312B4, 30L1, or 30S1 and SM-3. Willing to pay top dollar for the station I have wanted since age 13. 1-512-925-3907 (cell), 1-888-917-9077(home), toll free residential, [willbryant@aol.com](mailto:willbryant@aol.com) WA5JUL Bill Bryant. **THIS STATION IS FOR PERSONAL USE, NOT FOR RESALE!** BNB700

**ARIZONA STATE CONVENTION AND HAMFEST.** Largest **FREE ADMISSION** Hamfest in the Southwest. July 28, 29, and 30, 2000. I-17 exit 337 (Ft. Tuthill), Flagstaff, AZ. Our 49th consecutive year. Manufacturers, Dealers, Exhibits, Seminars, VE Testing. Huge Swap. Camping and more. Gordon West, WB6NOA, will present two of his famous seminars and will be the (TBA) guest speaker at the Sat. night BBQ. Other speakers, seminars and forums include Dan Miller from ARRL Headquarters, and Bill Pasternak from Newsline. AMSAT, APRS, Ten-Tec, International, WRP, Ladies programs, and ARRL Forum. For more information, contact Amateur Radio Council of Arizona, POB 312, 16845 N 29th Avenue, Suite 1, Phoenix, AZ. 85080-2003 or Email: [arcathill@aol.com](mailto:arcathill@aol.com). Voice mail 1-602-779-2722. Web site: <http://www.Hamsrus.com>. Enjoy cool weather and the pines. An ARRL-sanctioned event. BNB702

## Subscriptions to 73 Magazine

Only \$24.97 — 1 year  
\$44.97 — 2 years  
\$65.00 — 3 years\*

\*best buy (54% off cover price!)

Call 800-274-7373



**FT-1000MP**  
The radio of choice for world-class contest operators, the FT-1000MP provides 100 Watts of power, Enhanced DSP,™ Dual In-band Receive, Cascaded IF filters, General Coverage RX, and 160-10 M TX. (DC-only version also available.)



**FT-920**  
The FT-920 HF/6M Transceiver is designed for today's active Ham. It features high-speed DSP in all modes, 127 memory channels, AFSK or FSK Digital operation, new-technology MOSFET PA finals, high-speed Automatic Antenna Tuner, and high-resolution LCD display.



**FT-1000D**  
Truly an elite-class HF masterpiece, the 200 Watt FT-1000D provides Dual Receive (in-band or cross-band), Cascaded IF Filters, extraordinary Dynamic Range, DDS, high-speed Automatic Antenna Tuner, and 100 memory channels.



**FT-100**  
This ultra-compact HF/VHF/UHF 100 Watt Transceiver provides SSB, CW, AM, FM and AFSK coverage of the HF, 6M, 2M and 70 CM bands. Features include 300 memory channels, built-in Electronic Memory Keyer, DSP, IF Shift, IF Noise Blanker, and CTCSS/DCS.



**FT-840**  
Affordable yet feature filled, the FT-840 is an ideal traveling companion. It offers 160-10M TX with general coverage RX, 100 memory channels, DDS, CTCSS, Twin Band Stacking VFOs, and excellent receiver dynamic range.



**FT-600**  
This compact 100 Watt HF Transceiver offers the utmost in operating simplicity. The MIL-STD rated FT-600 covers the 160-10M Amateur bands with General Coverage Receive, 100 memory channels, Direct Keypad Frequency Entry, and a front-mounted speaker.



**VL-1000/VP-1000**  
The VL-1000 Quadra System is a Solid-State Linear Amplifier featuring four twin-MOSFET PA modules to produce 1000 Watts of clean power output on 160-15 Meters (500 Watts on 6M, modifiable for 12/10 meters). Included are an Automatic Antenna tuner, 2 Input and 4 Output Antenna Jacks, and extensive status displays on the multi-function LCD.

**FT-847**  
The introduction of the FT-847 completely redefines base station operation by offering three radios in one—HF, VHF/UHF and Satellite. A full power multi-mode transceiver, the appropriately named Earth Station covers the HF, 50 MHz, 144 MHz and 430 MHz bands, and it includes crossband Full Duplex operating capability for satellite work. Its exceptional receiver performance is ready for all aspects of DX work thanks to the DSP filtering. And for local FM work both CTCSS and DCS encode/decode are built in. The FT-847 is an engineering breakthrough offering you the earth, the sky, and the moon in one compact package.



# THE TASK MASTERS.

They're out there. Those elusive DX signals that can't poke through the QRM regardless of the late-night hours you put in trying to find them. But when a Yaesu HF enters the picture, weak signals suddenly jump into your headphones. Yaesu's High Frequency transceiver technology uniquely combines years of RF and AF design know-how with cutting edge advancements in IF filtering, noise reduction, and dynamic range. Whether you're on high bands or low, at home or away, the high frequency technology of Yaesu's task masters quickly fills up your log with contacts. Learn more about Yaesu products on the web at [www.yaesu.com](http://www.yaesu.com)

**YAESU** Choice of the world's top DX'ers.

©1999 Yaesu USA, 17210 Edwards Road, Cerritos, CA 90703, (562) 404-2700. Specifications subject to change without notice. Specifications guaranteed only within amateur bands. Some accessories and/or options are standard in certain areas. Check with your local Yaesu dealer for specific details.

**An APRS® transceiver built for tomorrow's communication needs with advanced features available today.**

**NEW!**



## TM-D700A DATA COMMUNICATOR 144/440MHz FM Dual Bander

Conspicuous with its extra-large amber & black display, Kenwood's new TM-D700A is fully equipped to make the most of the exciting opportunities offered by the Kenwood Skycommand System, SSTV, GPS and APRS® –the Automatic Packet/Position Reporting System that is rapidly gaining popularity worldwide. This mobile transceiver with built-in TNC offers a wide range of data communications options, including simple packet operation using the AX.25 protocol. You can also send and receive SSTV images using Kenwood's VC-H1. Ham radio is truly entering a new era.

### APRS® (Automatic Packet/Position Reporting System)

- ▶ **Position/directional data**  
With an NMEA-0183 compatible GPS receiver you can transmit position data for automatic calculation of distance, current speed and heading. Last 4 digits can be masked for position ambiguity. Manual input of latitude/longitude is also possible.
- ▶ **Versatile messaging**  
Transmission of position data can be accompanied by a choice of programmable status text (up to 28 characters), position comments (15 settings), icons and bulletins. For added messaging flexibility, individual alpha messages (up to 64 characters) can also be sent.
- ▶ **Station list**  
Store received APRS® data in up to 40 station reports.
- ▶ **Grid square locator**  
Position data is displayed on the grid square locator for visible reference.

- ▶ **BCON TX interval**  
(0.2/0.5/1/2/3/5/10/20/30 min.)
- ▶ **Packet path selection for Digipeat**
- ▶ **Weather station & PHG data reception**
- ▶ **Digipeat station and DIGI function capability**
- ▶ **Auto Message Reply**
- ▶ **Audible APRS® message receive**  
(call sign) notification (requires VS-3)
- ▶ **Waypoint position data output**



### FEATURES

- ▶ Full Dual-band operation: VHF x VHF/VHF x UHF/UHF x UHF ▶ Wide-band receive: 118-524, 800-1300 MHz (excluding cellular blocked + frequencies)
- ▶ Detached panel (extension cable and panel holder supplied) with extra-large (188 x 54 dots) backlit LCD and multifunction key display (reversible) ▶ Improved key operation announcement with optional VS-3 voice synthesizer ▶ Built-in 1200/9600bps TNC compliant with AX.25 protocol and KISS mode ▶ Simplified packet monitoring ▶ SSTV functions with Fast FM for transmission of images in just 14 secs (approx.) and dual receive for voice and image transmissions (two frequencies simultaneously) ▶ 200 memory channels with 8-character memory name input ▶ Up to 10 programmable memory scan banks
- ▶ Easy-to-use menu system similar to the TH-D7A ▶ Built-in DCS (Digital Code Squelch) and CTCSS encode and decode ▶ CTCSS tone frequency scan ▶ DCS code scan
- ▶ 9600bps PC-based packet communications for chat, BBS

- ▶ Kenwood Skycommand System (KSS) II for remote control of fixed HF transceiver (TS-570S/D(G) or TS-870S) ▶ DX packet cluster monitoring ▶ Cross-band repeater ▶ Wireless remote controller ▶ 1750Hz tone burst ▶ D-sub 9 pin terminal (for PCs) ▶ GPS input terminal (NMEA-0183) ▶ Visual band scope ▶ Mute function ▶ Memory control program available via Internet access ▶ New backlit microphone with alphanumeric message input.



Example A: with GPS receiver & laptop



Example B: with VC-H1



**KENWOOD**  
Amateur Radio Products Group

KENWOOD COMMUNICATIONS CORPORATION  
AMATEUR RADIO PRODUCTS GROUP  
P.O. Box 22745, 2201 E. Dominguez St., Long Beach, CA 90801-5745, U.S.A.  
Customer Support/Brochures (310) 639-5300  
KENWOOD ELECTRONICS CANADA INC.  
6070 Kestrel Road, Mississauga, Ontario, Canada L5T 1S8 99ARD-1950

ISO 9001  
JQA-1205

Communications Equipment Division  
Kenwood Corporation  
ISO9001 Certification

**INTERNET**

Kenwood News & Products  
<http://www.kenwood.net>  
Kenwood Bulletins  
<ftp://ftp.kenwood.net>