

Including Ham Radio Fun!

APRIL 1998
ISSUE #451
USA \$3.95
CANADA \$4.95

73[®]

Amateur Radio Today

International Edition

**Ramsey
FX-146 Mods**

**De-Noising
Your PC**

**Home-Brew
2m Antenna**



Reviews: Hamtronics' \$50 Converter Kit!

Quickie All-Band Stealth Antenna

Controller for Fox Hunting



SYNTHESIZED VHF FM EXCITER & RECEIVER MODULES

No more waiting for crystals!



Hamtronics is pleased to announce a new line of its vhf fm transmitters and receivers, popular for repeaters, voice and data links, control, telemetry, and other demanding applications.

T301 Exciter and R301 Receiver provide high quality nbfm and fsk operation on 144-148 MHz (and 148-174 MHz for export and gov't services). Features include:

- Dip switch frequency selection.
- Exceptional modulation for voice and ctcss.
- Very low noise synthesizer for repeater service.
- Direct fm for data up to 9600 baud.
- Commercial grade tcxo for tight frequency accuracy in wide range of environmental conditions: 2ppm -30 to +60°C.
- In stock for same day shipping.

T301 EXCITER

Rated for continuous duty, 2-3W output.

- Kitonly \$109
- TCXO option ...\$40
- Wired/tested ...\$189 (includes TCXO)
- Inquire about models for higher frequencies.

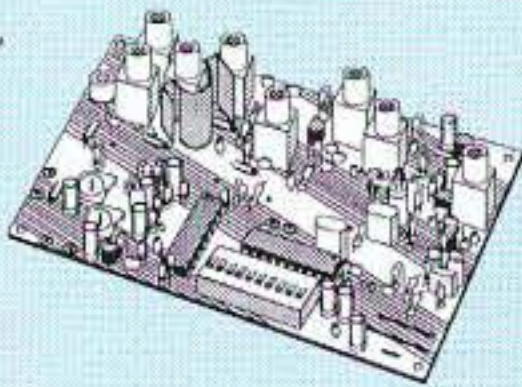

R301 RECEIVER

- Kitonly \$139
- TCXO option ...\$40
- Wired/tested ...\$209 (includes TCXO)
- Our traditional crystal-controlled receivers and exciters are still available for all vhf and uhf bands.

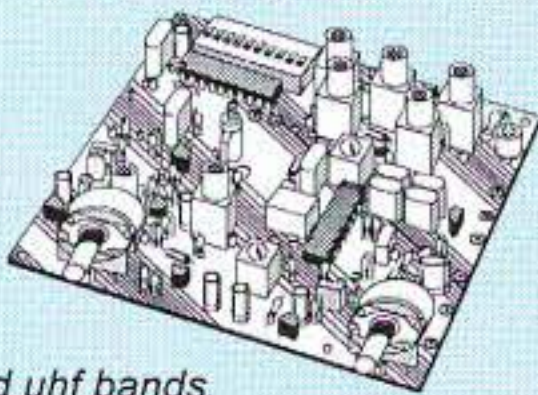

CRYSTAL CONTROLLED VHF & UHF FM EXCITERS & RECEIVERS

FM EXCITERS: 2W output, continuous duty.

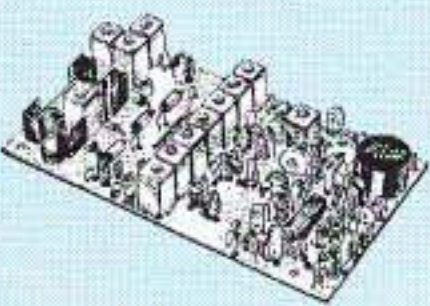

- TA51: for 6M, 2M, 220 MHz kit \$99, w/t \$169.
- TA451: for 420-475 MHz. kit \$99, w/t \$169.
- TA901: for 902-928 MHz, (0.5W out) w/t \$169.

VHF & UHF POWER AMPLIFIERS.

Output levels from 10W to 100W Starting at \$99.

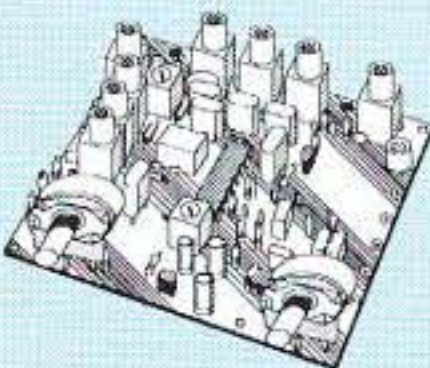

FM RECEIVERS:

- R100 VHF FM RCVR Very sensitive - 0.15µV. Superb selectivity - both crystal and ceramic IF filters, >100 dB down at ±12 kHz, best available anywhere, flutter-proof squelch.

For 46-54, 72-76, 140-175, or 216-225 MHz. kit \$129, w/t \$189.

- R144 RCVR. Like R100, for 2M, with helical resonator in front end. kit \$159, w/t \$219.
- R451 FM RCVR, for 420-475 MHz. Similar to R100 above. kit \$129, w/t \$189.
- R901 FM RCVR, 902-928MHz \$159, w/t \$219.

Get more features for your dollar with our REP-200 REPEATER

A microprocessor-controlled repeater with full autopatch and many versatile dtmf remote control features at less than you might pay for a bare bones repeater or controller alone!

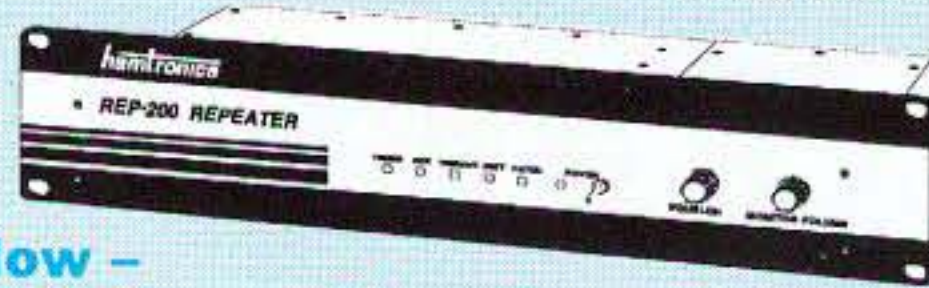

Now - 2 meter machines in stock for next day shipment!

- kit still only \$1095
- factory assembled still only \$1295

50-54, 143-174, 213-233, 420-475 MHz. (902-928 MHz slightly higher.)
 * FCC type accepted for commercial service in 150 & 450 MHz bands.

Digital Voice Recorder Option. Allows message up to 20 sec. to be remotely recorded off the air. Play back at user request by DTMF command, or as a periodical voice id, or both. Great for making club announcements! only \$100.

REP-200C Economy Repeater. Real-voice ID, no dtmf or autopatch. Kit only \$795, w&t \$1195.

REP-200N Repeater. Without controller so you can use your own. Kit only \$695, w&t \$995.

You'll KICK Yourself If You Build a Repeater

Without Checking Out Our Catalog First!

Hamtronics has the world's most complete line of modules for making repeaters. In addition to exciters, pa's, and receivers, we offer the following controllers.

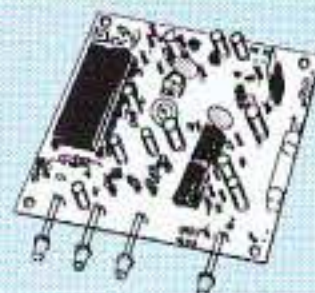

COR-3. Inexpensive, flexible COR module with timers, courtesy beep, audio mixer. only \$49/kit, \$79 w/t.

CWID. Traditional diode matrix ID'er. kit only \$59.

CWID-2. Eeprom-controlled ID'er. only \$54/kit, \$79 w/t.

DVR-1. Record your own voice up to 20 sec. For voice id or playing club announcements. \$59/kit, \$99 w/t.

COR-4. Complete COR and CWID all on one board. ID in eeprom. Low power CMOS. only \$99/kit, \$149 w/t.

COR-6. COR with real-voice id. Low power CMOS, non-volatile memory. kit only \$99, w/t only \$149.

COR-5. µP controller with autopatch, reverse ap, phone remote control, lots of DTMF control functions, all on one board, as used in REP-200 Repeater. \$379 w/t.

AP-3. Repeater autopatch, reverse autopatch, phone line remote control. Use with TD-2. kit \$89.

TD-2. Four-digit DTMF decoder/controller. Five latching on-off functions, toll call restrictor. kit \$79.

TD-4. DTMF controller as above except one on-off function and no toll call restrictor. Can also use for selective calling; mute speaker until someone pages you. kit \$49.

SUBAUDIBLE TONE ENCODER/DECODER

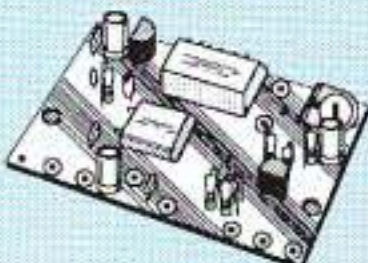

Access all your favorite closed repeaters!

- Encodes all standard CTCSS tones with crystal accuracy and convenient DIP switch selection.

- Comprehensive manual also shows how you can set up a front panel switch to select tones for several repeaters.
- Decoder can be used to mute receive audio and is optimized for installation in repeaters to provide closed access. High pass filter gets rid of annoying buzz in receiver.

- TD-5 CTCSS Encoder/Decoder Kit only \$39
- TD-5 CTCSS Encoder/Decoder Wired/tested \$59

LOW NOISE RECEIVER PREAMPS

LNG-() GaAs FET PREAMP

STILL ONLY \$59, wired/tested

- Make your friends sick with envy! Work stations they don't even know are there.
- Install one at the antenna and overcome coax losses.
- Available for 28-30, 46-56, 137-152, 152-172, 210-230, 400-470, and 800-960 MHz bands.

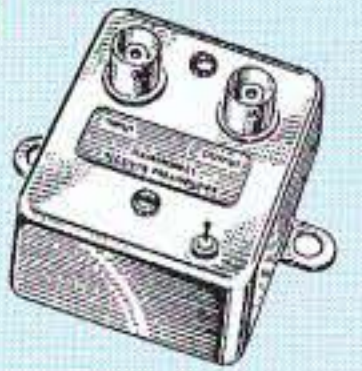

LNW-() ECONOMY PREAMP

ONLY \$29 kit, \$44 wired/tested

- Miniature MOSFET Preamp
- Solder terminals allow easy connection inside radios.
- Available for 25-35, 35-55, 55-90, 90-120, 120-150, 150-200, 200-270, and 400-500 MHz bands.

WWW RECEIVER

Get time & frequency checks without buying multiband hf rcvr.

Hear solar activity reports affecting radio propagation. Very sensitive and selective crystal controlled superhet, dedicated to listening to WWV on 10 MHz. Performance rivals the most expensive receivers.



- RWWV Rcvr kit, PCB only \$59
- RWWV Rcvr kit with cabt, spkr, & 12Vdc adapter \$89
- RWWV Rcvr w/t in cabt with spkr & adapter \$129

WEATHER FAX RECEIVER

Join the fun. Get striking images directly from the weather satellites!

A very sensitive wideband fm receiver optimized for NOAA APT and Russian Meteor weather fax images on the 137 MHz band.

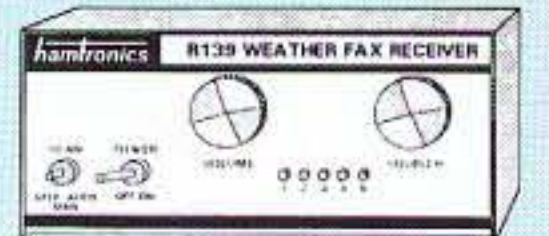

The R139 is lower cost and easier to maintain than synthesized units. And it is designed from the ground up for optimum satellite reception; not just an off-the-shelf scanner with a shorted-out IF filter!

Covers all five satellite channels. Scanner circuit and recorder control allow you to automatically search for and tape signals as satellites pass overhead, even while away from home.

- R139 Receiver Kit less case \$159
- R139 Receiver Kit with case and AC power adapter \$189
- R139 Receiver w/t in case with AC power adapter ...\$239
- Internal PC Demodulator Board and Imaging Software \$289
- Turnstile Antenna \$119
- Weather Satellite Handbook \$20

WEATHER ALERT RECEIVER

A sensitive and selective professional grade receiver to monitor critical NOAA weather broadcasts. Good reception even at distances of 70 miles or more with suitable antenna. No comparison with ordinary consumer radios!



Automatic mode provides storm watch, alerting you by unmuting receiver and providing an output to trip remote equipment when an alert tone is broadcast. Crystal controlled for accuracy; all 7 channels provided (162.40 to 162.55).

You can buy just the receiver pcb module in kit form or buy the kit with an attractive metal cabinet, AC power adapter, and built-in speaker. It is also available factory wired and tested.

- RWX Rcvr kit, PCB only \$79
- RWX Rcvr kit with cabinet, speaker, & AC adapter \$99
- RWX Rcvr wired/tested in cabinet with speaker & adapter \$139

Buy at low, factory-direct net prices and save!

For complete info, call or write for complete catalog.

Order by mail, fax, email, or phone (9-12, 1-5 eastern time).

Min. \$5 S&H charge for 1st lb. plus add'l weight & insurance.

Use Visa, MC, Discover, check, or UPS C.O.D.



View Catalog on our Web Site:

www.hamtronics.com

email: jv@hamtronics.com

Our 35th Year
hamtronics, inc.
 65-D Moul Rd; Hilton NY 14468-9535
 Phone 716-392-9430 (fax -9420)

Get on the Outernet!™

There's a Kantronics 9612 Plus about to enter service aboard Mir

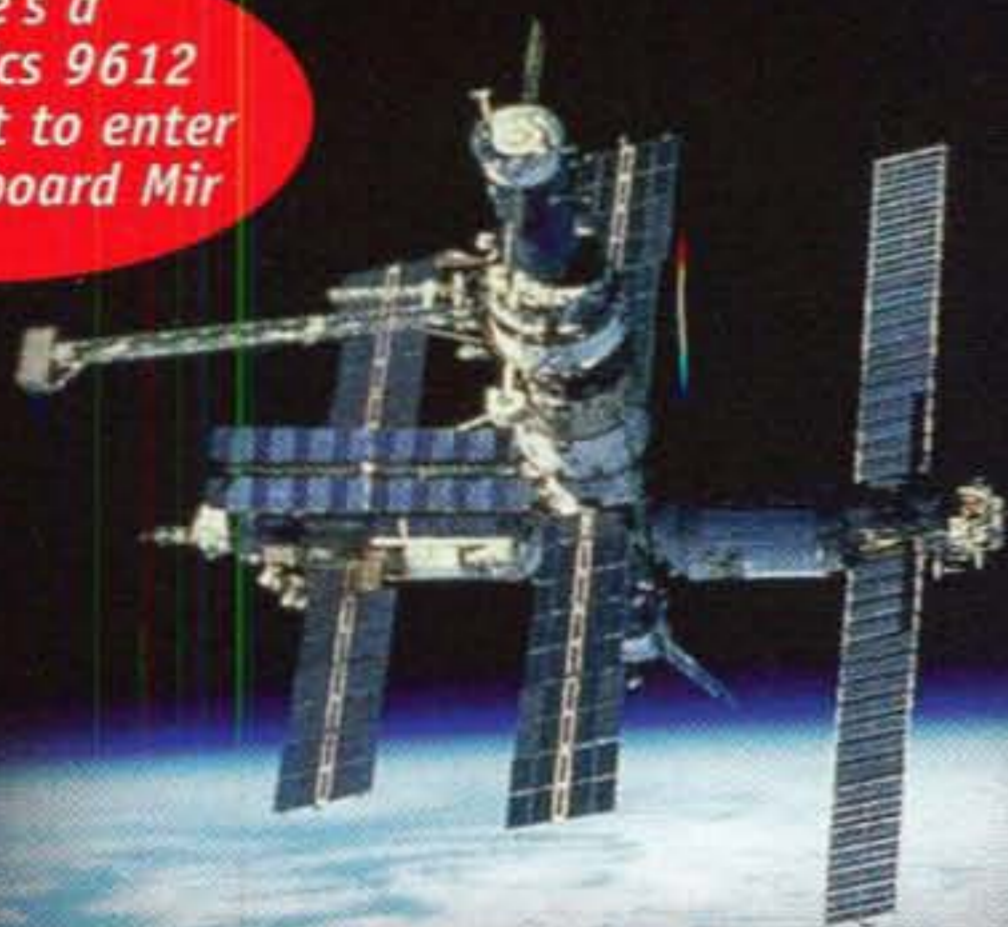

There's a world of digital communications fun and adventure that *only hams can enjoy* and Kantronics makes it possible for you to explore it. No matter if you call our products TNCs, wireless modems or digital controllers, the "Outernet™" offers a world of adventure, including satellite communications, APRS®, DX spotting, BBS operations, WEFAX, EMWIN, TCP/IP links, remote control and sensing, telemetry, HF e-mail with commercial service providers and more!

Commercial versions of Kantronics TNCs are being used in ever-increasing numbers!

Kantronics offers a number of ways to enjoy the growing field of digital communications. Choose the unit that suits your interests and budget. All Kantronics units come with a one-year limited warranty and can be upgraded when firmware updates become available.

KPC-3 Plus



- 1200 bps - Now with more features!
- Packet, GPS/APRS, Host, KISS and WEFAX modes
- Personal Mailbox (PBBS) now supports multiple calls
- Copies NWS EMWIN with optional software
- Remote access, sensing and control with two A/D and two control lines
- KA-Node or option K-Net networking capability
- PBBS 100k, expandable with optional 512k RAM
- Uses external power or internal 9v battery
- NEWUSER mode and online help

8.2 Firmware now with Advanced GPS/APRS UI digipeating available for all 3 models!

KPC-9612 Plus



- 1200 port AND second port of 4800 ~ 38,400 bps
- Most modes/capabilities of the KPC-3 Plus and POCSAG (paging)
- Unique design allows the addition of *another port, high or low speed**
- KA-Node or K-Net option works with multiple ports
- Remote access, sensing and control capability
- Telemetry transmission capability
- NEWUSER mode and online help

KAM Plus



- Same great KAM Plus performance in an attractive new package!
- Dual port VHF/HF (1200/≤300 bps) multimode TNC
- Packet, GPS/APRS, Host, KISS, WEFAX, CW, RTTY, AMTOR, PACTOR, G-TOR™, TOR, and Free Signal Detection for HF e-mail
- 100k personal mailbox standard, expandable with optional 512k RAM
- Remote access capability
- Real time, battery backed clock
- NEWUSER mode and online help
- New style case available for older Kam Plus units

Kantronics

1202 E. 23rd St., Lawrence, KS 66046
tel: 785-842-7745 • fax: 785-842-2031
e-mail: sales@kantronics.com
web: www.kantronics.com

Specifications subject to change without notice or obligation. APRS® is a registered trademark of Bob Bruninga, WB4APR. All registered trademarks remain the property of their respective owners. *Expansion modules anticipated for availability in early 1998.

Number 1 on your Feedback card

NEVER SAY DIE

Wayne Green W2NSD/1

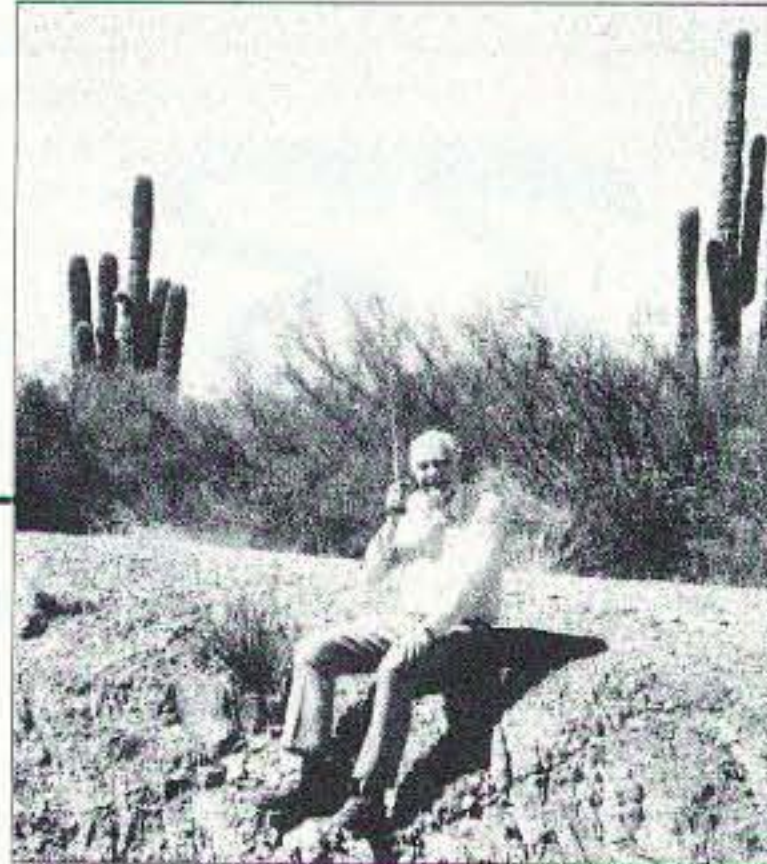

Depressing, Isn't It?

Depression is difficult to tackle because there are several potential contributing factors. #1 is psychological, where a person is faced with a seemingly insoluble problem and just gives up. #2 is also psychological, the result of childhood abuse. This is similar to #1, in that the child suffering the abuse is unable to cope with it and gives up. Unfortunately this lingers on as teenage depression and, according to a study at UNH, correlates with teenage suicide. #3 has to do with both lousy nutrition and the possible allergic sensitivity to something being eaten or in the environment.

I was depressed a good deal during my teens and 20s as a result of childhood beatings by my father. This is now called child abuse. My life was totally changed when I was 28 and discovered a super-fast and highly effective psychotherapy. It did in hours what few psychiatrists even hoped to do in years. I got very good at using this approach, but I gave it up when I found that very few people really wanted to improve their lives.

Allergies can exacerbate depression. I've got a couple of good books on that subject around here somewhere.

If our bodies are getting the nutrition they need — including the minerals missing in our supermarket food, and we're drinking distilled water instead of city-provided sludge, we're exposed to actual sunlight, breathe fresh unpolluted air, and avoid the usual poisons such as pesticides™.

sugar, white flour, dental amalgam, root canal teeth, fluorides, hydrogenated fats, etc., and we get plenty of exercise, then depression is highly unlikely. Hey, some music won't hurt, either. A two-mile brisk walk in the sun every day, exercising with hand/wrist weights, rolling the eyes instead of just looking straight ahead, hyperventilating and breathing totally in and out of the lungs will do a lot to get rid of depression.

People who prefer to live in the city, where the air is polluted, and eat Danish and coffee for breakfast, are going to have to recognize that this is going to cut their normal life span about in half. A short life, but a merry one, right? Merrier than living out in the country on a small farm, where the air is pure, the sunlight unfiltered by smog, where you can run your own small mail-order business and fit in an hour's walk every day? Where the EMFs are minimal, the neighbors a half mile or so away, and you can grow your own food, complete with the minerals missing from the supermarket stuff. Sure, give me the city, with its grime, smog, crime, drugs, \$20-a-day parking, \$500 apartment rentals, and so on every time. Oh, I almost forgot the rudeness of your neighbors, the stress and constant aggravation.

As I write this I'm looking out of the window at nine damned deer eating my hedge. Go away! And then I chuckle as I read pathetic letters from hams living in houses or even towns with an

But all that doesn't have much to do with depression. When you're depressed you don't have the initiative to get out of the mess you're in, so it just gets worse. It takes a lot of initiative to work out the details of how to move yourself and your family from an apartment in Brooklyn or San Francisco to a farm in New Hampshire or Oregon, two or three hundred miles and a lifetime away.

Thus, step number one in fighting depression is to tackle the easy parts: nutrition and exercise. A switch to raw foods, with mineral and vitamin supplements, plus a daily brisk walk or jog for a couple of miles and a few minutes listening to good music should get you out of your funk enough to start planning a better life for you and your family. How about that big antenna farm you can have, eh? And maybe some chickens running around your yard. I've got a couple chickens, a duck, a turkey and three rabbits running around mine. And that doesn't count the wild turkeys and pheasants in the fields where I walk.

Exposed

A reader whose expertise is hospital electronic equipment explained that one of the hospital regulations requires the use of special wall outlets for safety grounding reasons. Besides being a bonanza for the only firm making 'em, there's a rule that they have to be tested regularly. Most hospitals have two men whose jobs are

the reports. But, since nothing goes wrong with the outlets the men spend 40 hours a week falsifying their reports. The cost of maintaining these special outlets per year, not counting the paid maintenance men doing the tests, costs an average of \$50,000 a year per hospital.

All of which may help to explain why hospitals cost so much when you need 'em.

Of course, if you pay attention to my recommendations, you're not likely to need a hospital unless you suffer an accident.

The Begging Bowl

I got a form letter recently from Ambassador Petrone, who lives in the next town over. He was asking me to donate money to the Republican party. For a couple of thousand bucks I could become a NH GOP Club member. Wow! It reminded me of the endless letters I got from presidents Reagan and Bush asking for donations. Anyway, here's what I wrote the good ambassador. No, I didn't get any reply.

Why did the Republicans lose the last governor's race? Was it money? Was it a lack of good management of the campaign? Was it a weak candidate? Was it a serious lack of a stated program for achieving the Republican goals? For that matter, are there any actual specific stated Republican goals, or are they amorphous ... less government, less taxes? I haven't seen any plans for achieving that mentioned anywhere.

And, by the way, where does donated money go? For generous salaries? For whom? Is there any accounting to us Republicans of the revenues and expenses of the NH Republican party? How can I find out about this? My suspicion is that there is a crisis of leadership in NH that more money is only going to make worse, just as government spending has made virtually every other social problem we face worse.

Politicians can only be stopped in their spending by

credit, as ex-Governor Gregg once explained ... and as we've seen proven endlessly. And since the NH Republican party is run by politicians, is there any reason to believe that our party leaders are working with a different agenda?

We *do* have some serious problems: really bad schools, a corrupt health care industry, a corrupt Congress, a corrupt Administration, a judiciary that ignores the Constitution in its social engineering efforts, a mineral- and vitamin-deficient food supply, endless poisoning of our people — sanctioned by the government, a drug war that's totally failed, a war on poverty that has failed, and so on. There are some fairly simple solutions to all of the above, but you'd never know it from listening to our politicians, Republican or Democrat.

You mentioned people will pitch in if there is "direction and leadership." Is there any? I know I've seen no signs of any.

Permission is granted to use my letter format as an answer every time a politician rattles his begging bowl. Just input it in your computer and print out a copy when you need it.

QCWA

When the QCWA endorsed the continuation of the code test as the major barrier to a ham license, I wrote the following letter. I'll bet you won't believe that they didn't publish it. Or even answer.

Barry: The latest issue of the *QCWA Journal* arrived — nice job. And I know how much work it takes to put out a magazine. But, you know, I didn't see any invitation for letters or comments. I respect that the ARRL has made it abundantly clear that the QCWA being active in amateur politics is not an option. Ask past-president Harry Gartsman W6ATC about what happened when the club timidly ventured into that arena.

I was delighted to read that the club officers are 100% in support of the code test. I couldn't agree more. 1000%! The only small complaint I

have is that the entry (Novice) test should be raised to at least 20 wpm. This will help keep the riff-raff, CBers, and nuisance kids out of our fraternity.

When I joined a high school fraternity I underwent hazing. They forced me to chew lye soap and then drink Coke®. I'd never before tasted Coke, but despite the intense pain it inflicted on my raw and bleeding mouth, I've drunk dozens of bottles and a couple of cans in the ensuing 60 years. Hazing is an institutional ritual when joining a fraternity.

In college the hazing was even more rigorous (and painful) when I joined Sigma Chi. In addition to endless vigorous paddling, we pledges were put through a series of tried and tested rituals. Like when I was driven miles and then dumped on a deserted country road at midnight in a snowstorm and left to find my way back. Serendipity stepped in (Allah be praised!) and W2MAM came along minutes later, on his way to dump some of his pledges (from a different fraternity, just a few doors down from ours) in the middle of nowhere. So I got back before my fraternity brothers. Yes, of course I was punished! I also was given five minutes to learn the Greek alphabet — which I still remember. It comes in handy every now and then, doing crossword puzzles.

So, fraternity hazing is acceptable as long as too many pledges don't get killed. And in the ham fraternity our major hazing instrument is the code. No, it serves no useful purpose any more, other than as a means for old-timers to have fun. But that's what ham radio is all about these days, right? Our ability (and the need) to provide skilled technicians and operators for the military is long gone. Our public service days are winding down, supplanted by cellular telephones. It's been

decades since we contributed technically to the art. These days we are an elite group of aging survivors, doing our best to get all of the recognition we can from our group via contests such as DXCC, and we've done almost nothing to encourage newcomers in the last 30 years.

So, if we're going to keep down the HF QRM, the QCWA officers are 100% on target. Stick to the hazing. Force newcomers to take the time and do the hard work it takes to build a skill that for them seems almost completely useless and will soon be lost, making the whole thing an enormous waste of time and effort. With over 90% of what few active HF hams we have left on voice, I can understand their complaint. Heck, let's make it even more painful with a 20 wpm minimum. And make that retroactive, requiring Extra Class licensees to requalify when they renew their tickets. If the QCWA officers hon-

estly believe what they're saying about the code being important, then they should support this simple change.

Those FCC Auctions

Once Congress got the smell of money, the lid was off as far as auctioning off parts of the radio spectrum was concerned. From the Congressional point of view, it's been an \$11 billion bonanza. Whee! More money to spend! And that (it may come as a news flash to you) is the primary interest of Congress. The control of money is power.

Auctioning off spectrum to the highest bidders has its downsides. For one, it guarantees that the biggest corporations are almost certainly going to be the big winners. It takes deep pockets to come up with \$11 billion. For two, this means that it is unlikely that we, the public, are going to get the latest, greatest technology.

Continued on page 80

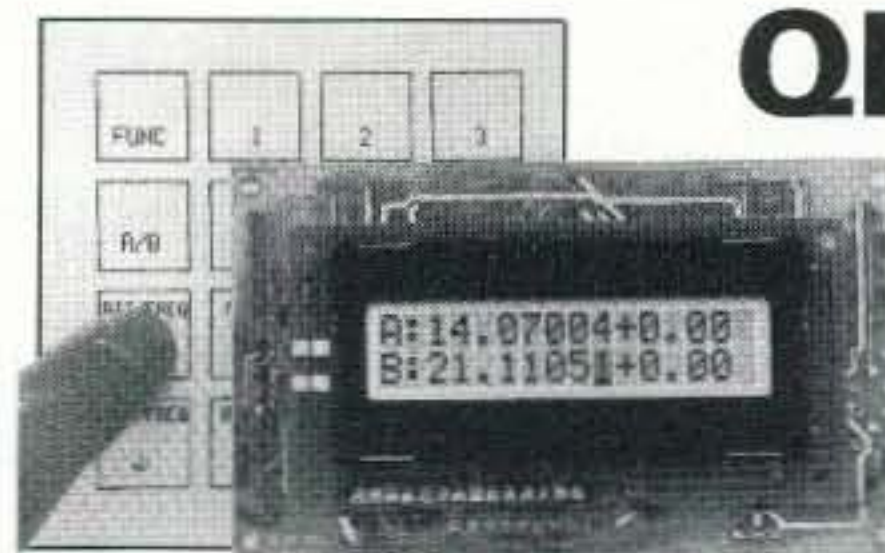

QRP VFO!

High power keypad controlled direct digital synthesis VFO for low power enthusiasts

Get base station performance from your QRP rig with keypad controlled VFO featuring:

- ✓ Keypad entry of frequency
- ✓ 10 Hz to 40 MHz frequency range
- ✓ Digital VFO with 10 Hz resolution & display
- ✓ Variable rate incremental keypad or rotary tuning
- ✓ Dual VFOs (A&B) allows cross band selection
- ✓ 100 memories for VFO A&B
- ✓ Keypad selection of bands
- ✓ RIT (+/- 9.99kHz)
- ✓ Size: L-4" X H-2.5" X D-0.9"

Special limited time introductory price: \$149 (U.S.) plus \$10 shipping

Order now and also receive the RS-232 option to control VFO operation via your PC. Orders: 1-800-923-3423.

Info: (Tel.) 905-470-2900 (Fax) 905-470-6742.

Menu Plus

Menu Plus Inc.
1271 Denison St., Units 56-57
Markham, Ontario, Canada L3R 4B5



CIRCLE 335 ON READER SERVICE CARD

LETTERS

From the Ham Shack

Kenneth E. Stone W7GFH. Some months ago I got interested in Thomas Miller's Bioelectrifier, reprinted in the May 1997 issue of 73. His statement that one should not use a 555, etc., which would result in complicated circuitry, voltage regulation, and high current, was an immediate challenge. Further, I wanted to build it with only materials on hand (no optocouplers). The result was a simpler circuit using a 555 oscillator with two transistors doing the current reversing and a third transistor as a phase inverter, since the 555 has only a single output. That circuit uses about one third the current of any of Miller's circuits. The duty cycle had a 5% unbalance, which appeared to be OK, since Miller said an equal duty cycle was not a goal nor even desired.

Now, in a private communication, Miller has contradicted himself and says the waveform must be exactly balanced or some serious effects may result. I am unable to find any other warning of this in 73. One of the characteristics of his own multivibrator is that it does not produce a balanced waveform, unless you carefully select components and measure the output to determine that it is indeed balanced. It is not likely that the many people using "Bioelectrifiers" have an exact 50% duty cycle, so be warned now. Miller warned that any unbalance will cause ion migration from the electrodes, and that heavy metal ions are both poisonous and cumulative. "Even silver ions absorbed in this manner are toxic. Any imbalance can also lead to more

exotic problems, such as hydrogen gas buildup in the blood."

I'm 75 years old, but I still remember a lot from getting my BA in chemistry and I have a lab here at home, so I looked into his warnings.

My original circuit using the 555 oscillator has a 5% unbalance, so if you set it for 100 microamps output, there will be an effective five microamps in one direction. How much metal can this cause to migrate? The calculation is relatively simple and it shows that if you use the device with the five microamps unbalance for one hour per day for one year, the absolute maximum ion migration from the positive electrode (that is the one they leave) for the following electrodes is as follows: aluminum 0.61 mg; silver 7.35 mg; iron 1.90 mg; nickel 2.00 mg; chromium 1.77 mg; copper 4.33 mg. My doctor laughed at these tiny quantities, and said you would get more chromium by rubbing your hand on a car bumper. The iron, chromium

and copper are essential minerals and you get more than those quantities in your food. Aluminum is not essential, but you get more than that every day in food, and a dose of most antacids puts you ahead by decades. Even a little ordinary baking powder gives you years of this amount of aluminum. Anyone who is allergic to nickel should stay away from any stainless steel that contains it, though many do not. As for the silver, the Merck Index™ says that any silver absorbed through the skin from silver compounds does not cause any serious toxic effects, but may color the skin gray. As far as being cumulative, that is doubtful, since if the other metals actually did pass through the skin they would be in ionic form, and chemically reactive with the body fluids. And as for the hydrogen buildup, if all the current was effective in forming hydrogen it would generate about a milliliter in the year. If all the current were concentrated in a single point and all went into making hydrogen gas, in one hour the bubble would be slightly over one millimeter in diameter, but, of course, it would form as an H⁺ ion, which is already in the body fluids and would be lost with just a theoretical change in pH. And to use Miller's tactics, remember, I'm a chemist, not a doctor.

I did not stop at just calculations. I used pairs of various electrodes separated by pads of cotton, wetted one time by salt water, and again with commercial deionized water. Beck and others recommend using wet paper or flannel between the electrodes and the skin. I weighed the electrodes before and after. The tests were run with 945 microamps of direct current for 10 to 12 hours each. Only when using quarters as electrodes was there any migration of metal ions through the pads onto the negative electrode, and that amounted to only 0.1 mg with plain water and 1.1 mg with salt water. It was only the

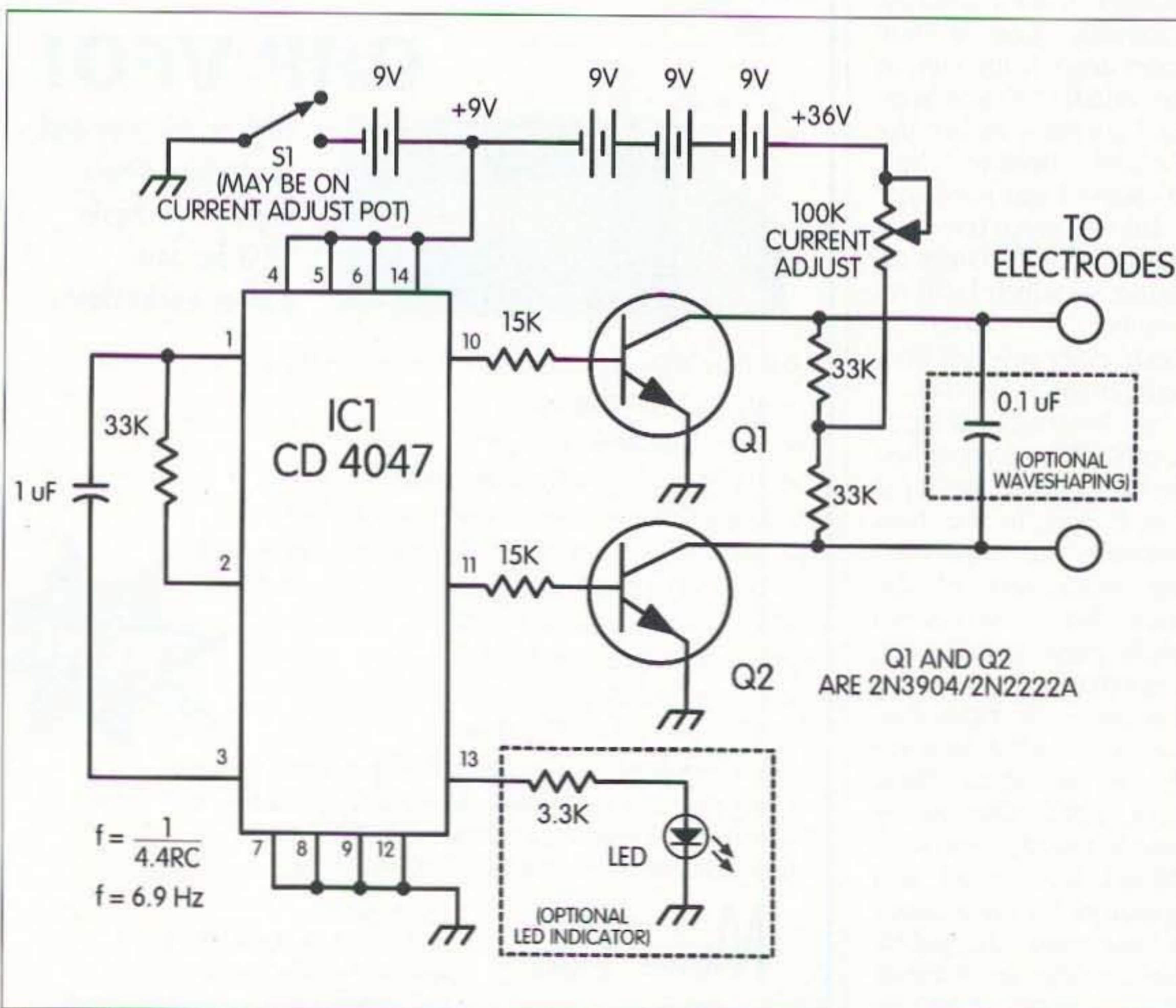

Fig. 1. W7GFH's simple bioenergizer schematic.

10 Bands -- 1 MFJ Antenna!

Full size performance . . . No ground or radials

Operate 10 bands: 75/80, 40, 30, 20, 17, 15, 12, 10, 6 and 2 Meters with one antenna
Separate full size radiators . . . End loading . . . Elevated top feed . . . Low Radiation Angle . . . Very wide bandwidth . . . Highest performance no ground vertical ever . . .

Operate 10 bands -- 75/80, 40, 30, 20, 17, 15, 12, 10, 6 and 2 Meters -- with this MFJ-1798 vertical antenna and get *full size performance* with no ground or radials!

Full size performance gives you high efficiency for more power radiated. The result? Stronger signals and more Q-5 QSOs.

Full size performance also gives you exceptionally wide bandwidths so you can use more of your hard earned frequencies.

Full size performance is achieved by using separate full size radiators for 2 through 20 Meters and highly efficient end loading for 30, 40 and 75/80 Meters.

Get very low radiation angle for exciting DX, automatic bandswitching, omni-directional coverage, and low SWR. Handles 1500 watts PEP SSB.

MFJ's unique *Elevated Top Feed™* elevates the feedpoint *all the way to the top* of the antenna. It puts the maximum radiation point high up in the clear where it does the most good -- your signal gets out even if you're ground mounted.

It's easy to tune because adjusting one band has minimum effect on the resonant frequency of other bands.

Self-supporting and just 20 feet tall, the MFJ-1798 mounts easily from ground level to tower top -- on small lots, backyards, apartments, condos, roof tops, tower mounts.

Separate Full Size Radiators

Separate full size quarter wave radiators are used on 20, 17, 15, 12, 10 and 2 Meters. On 6 Meters, the 17 Meter radiator becomes a 3/4 wave radiator.

The active radiator works as a stub to decouple everything beyond it. *In phase* antenna current flows in all parallel radiators.

MFJ Super Hi-Q Loop™

MFJ's tiny 36 inch diameter high efficiency loop antenna lets you operate 10 to 30 MHz continuously -- including the WARC bands!

It's ideal where space is limited -- apartments, small lots, mobile homes, attics, motor homes.

Enjoy both DX and local contacts when you mount it vertically. You get *both* low angle radiation for excellent DX *and* high angle radiation for local close-in contacts. Handles 150 watts.

Super easy-to-use! Only MFJ-1786 Super Remote Control has *Auto Band Selection™*. It auto-tunes to your desired band, then beeps to let you know. No control cable is needed.

Fast/slow tune push buttons and built-in two range *Cross-Needle* SWR/Wattmeter lets you quickly tune to your exact frequency.

All welded construction, no mechanical joints, welded butterfly capacitor with no rotating contacts, large 1.050 inch diameter round radiator -- not a lossy thin flat-strip -- gives you highest possible efficiency.

Each plate in MFJ's superb tuning capacitor is welded for low loss and polished to prevent high voltage arcing. It's welded to the radiator, has nylon bearing, anti-backlash mechanism, limit switches and a continuous *no-step* DC motor for *smooth precision* tuning.

A heavy duty 1/8 inch thick ABS plastic housing with ultraviolet inhibitors protects it. MFJ-1782 \$269.95. Same as MFJ-1786 but remote control has only fast/slow tune buttons.

NEW! MFJ-1788, \$359.95. Same as MFJ-1786 but covers **40 Meter through 15 Meter** continuous. Includes super remote control.



Super 80/40M Vertical

Designed as a high performance antenna for 80 and 40 Meters, the MFJ-1792 features a full size quarter wave radiator for 40 Meters -- that's a full 33 feet of ruthless radiating power.

End loading -- the most efficient form of loading -- is used for 80 Meters. It's accomplished by a virtually lossless 4 1/2 foot capacitance hat and a high-Q coil wound with Teflon® wire on a low-loss fiberglass form.

The entire length radiates power.

High strength 6061-T6 aluminum tubing, super strong solid fiberglass insulator, *Frequency Adaptive L-Network™*, heavy duty swing mount. Handles 1500 watts PEP. Requires guying and radials, counterpoises or ground screen.

MFJ-1793, \$179.95. Same as MFJ-1792 but includes full size 20 Meter quarter wave radiator.

Box Fan Portable Loop

No, it's not a fan -- it's a high efficiency portable loop antenna that's about the same size and shape as a 2x2 foot box fan, complete with carrying handle.

Carry it like a suitcase, tuck it in a corner of your car or check it as baggage on a plane.

When you get there, set it on a table or desk and enjoy ragchewing or DXing.

All welded construction, covers 14-30 MHz continuously including WARC bands, handles 150 watts. Remote control has fast/slow tune buttons. Separate control cable not needed.

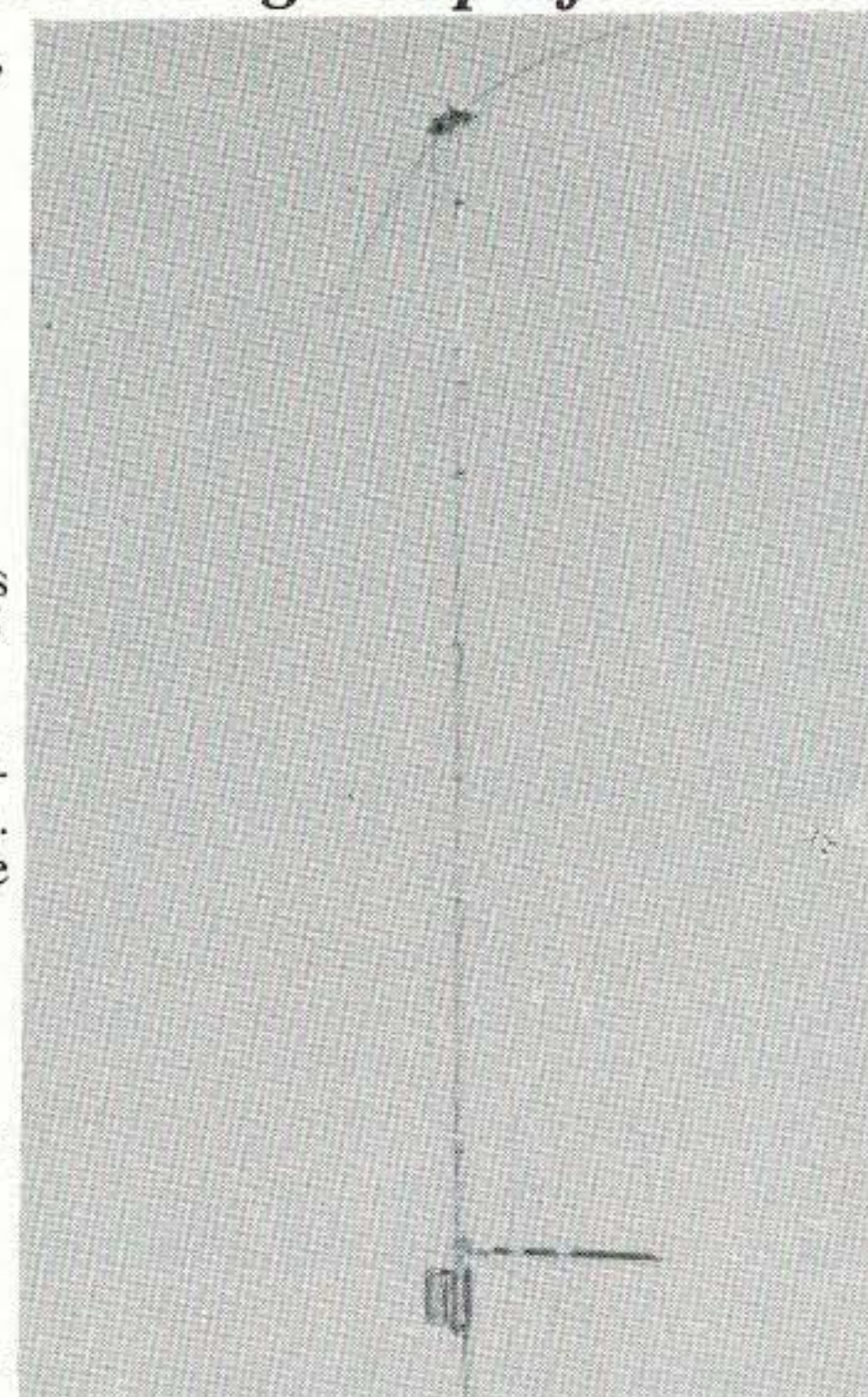

MFJ-1798
\$269⁹⁵

This forms a very large equivalent radiator and gives you incredible bandwidths.

These radiator stubs provide automatic bandswitching -- there is absolutely *no loss* due to loading coils or traps.

End Loading

On 30, 40, 75/80 Meters, end loading -- the most efficient form of loading -- gives you highly efficient performance, excellent bandwidth, low angle radiation and automatic bandswitching.

MFJ's unique *Frequency Adaptive L-Network™* provides automatic impedance matching for lowest SWR on these low bands.

Tuning to your favorite part of these bands is simple and is done at the *bottom* of the antenna.

No Ground or Radials Needed

You don't need a ground or radials because an effective counterpoise that's 12 feet across gives you *excellent* ground isolation.

You can mount it from ground level to roof top and get awesome performance.

No Feedline Radiation to Waste Power

The feedline is decoupled and isolated from the antenna with MFJ's exclusive *AirCore™* high power current balun. It's wound with Teflon® coax and *can't saturate*, no matter how high your power.

Built to Last

Incredibly strong solid fiberglass rod and large diameter 6061 T-6 aircraft strength aluminum tubing is used in the main structure.

Efficient high-Q coils are wound on tough *low loss* fiberglass forms using highly weather resistant Teflon® covered wire.

Teflon® is registered trademark of Dupont

MFJ halfwave Vertical

6 bands: 40, 20, 15, 10, 6, 2 Meters . . . No radials or ground needed!

Operate 6 bands -- 40, 20, 15, 10, 6 and 2 Meters -- with this MFJ-1796 ground independent halfwave vertical antenna! No radials or ground ever needed!

It's only 12 feet high and has a tiny 24 inch footprint! Mount it anywhere from ground level to tower top -- on apartments, condos, small lots, even motor homes. Perfect for vacations, field day, DX-pedition, camping.

Efficient end loading, no lossy traps. Entire length is always radiating. Full size halfwave on 2 and 6 Meters. High power air-wound choke balun eliminates feedline radiation. Adjusting one band has minimum effect on other bands.

Automatic bandswitching, low radiation angle, omni-directional, handles 1500 watts PEP. Goes together in an afternoon.

Free MFJ Catalog and free instruction manuals
Write or call toll-free . . . 800-647-1800

Nearest Dealer/Orders: 800-647-1800

<http://www.mfjenterprises.com>

Technical Support: (601) 323-0549

• 1 year unconditional guarantee • 30 day money back guarantee (less s/h) on orders from MFJ • Free catalog

MFJ MFJ ENTERPRISES, INC.
Box 494, Miss. State, MS 39762
(601) 323-5869; 8-4:30 CST, Mon-Fri
FAX: (601) 323-6551; Add \$20 s/h

MFJ . . . making quality affordable

Prices and specifications subject to change © 1995 MFJ Enterprises, Inc.

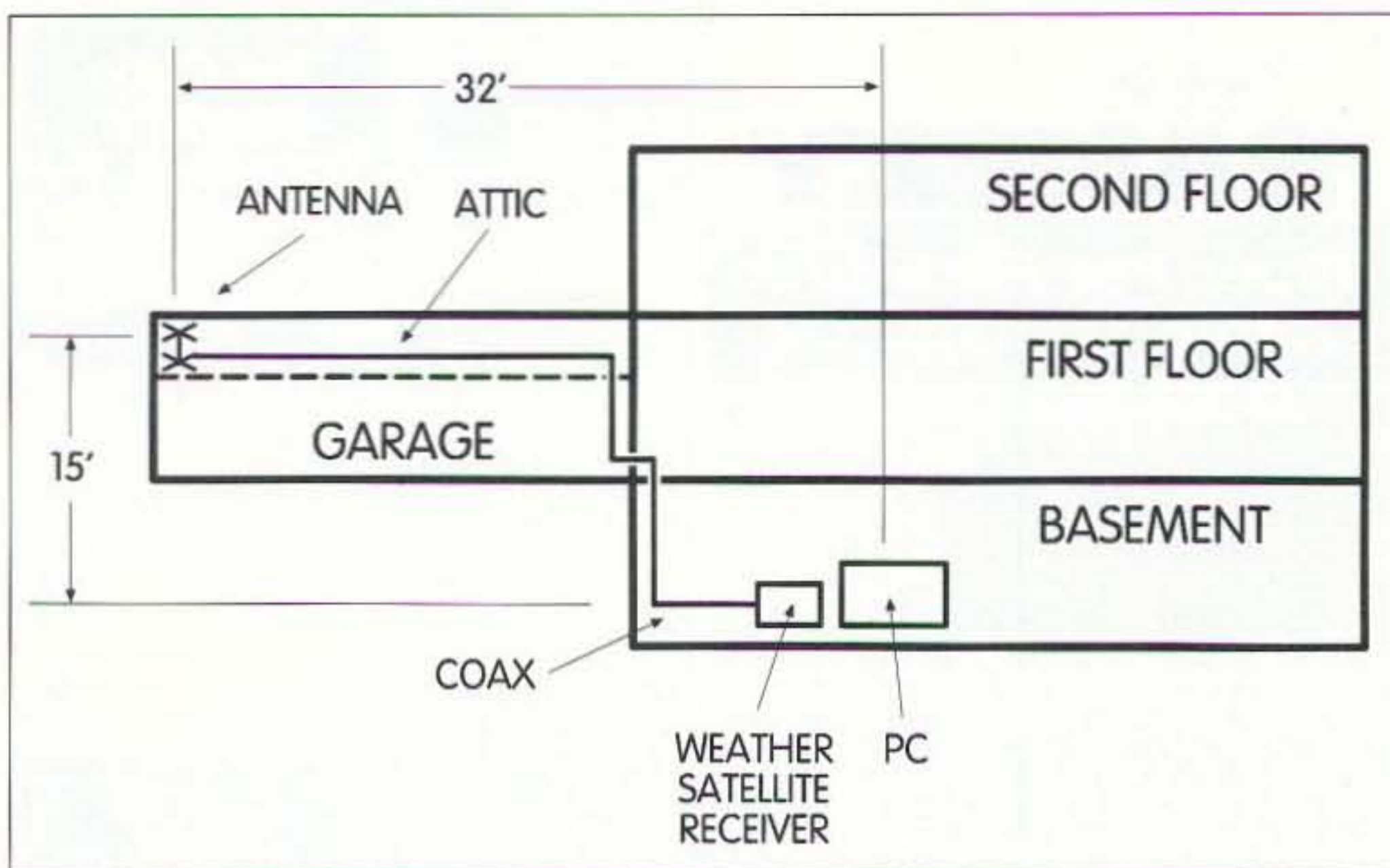

Fig. 1. 137 MHz interference being radiated from the basement PC to the antenna in the garage attic.

frequency range. All the frequency range labeling had been rubbed off, so I just picked a probe at random.

I connected it to my weather satellite receiver and began probing around inside the PC after powering it up with the case open. As I had suspected, the CPU chip generated a lot of noise at 137 MHz. The power supply leads were also very noisy. The disk controller card was noisy when I accessed the hard drive. As I pulled the probe a few inches away from the noisy locations, the signals dropped away to nothing. Aha! So this is how the professionals do it!

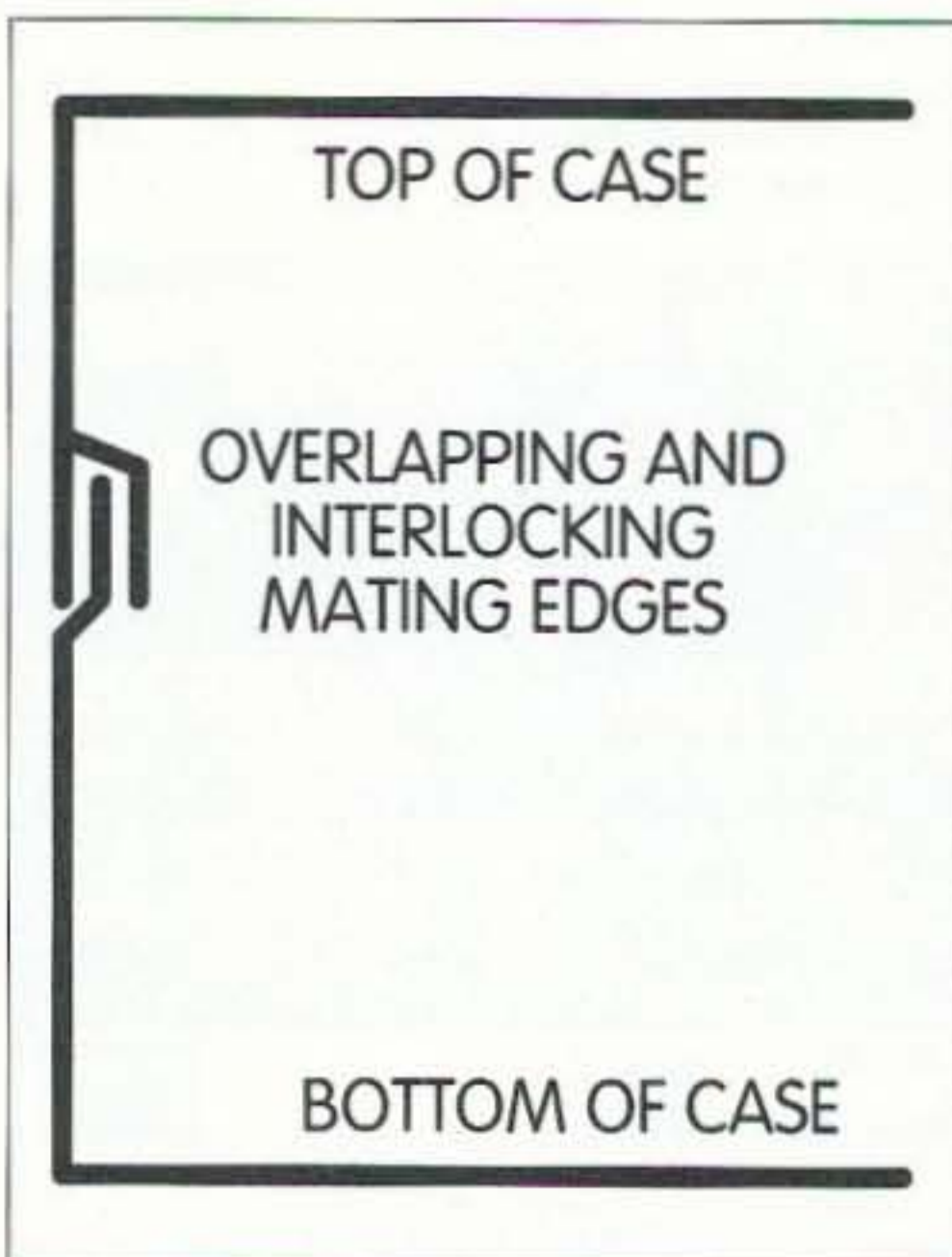

Fig. 2. Low-emission cases utilize interlocking panels to create an RF-tight enclosure.

I closed up the case, powered up the PC and began probing all around the case. The worst locations for EMI emission were the power supply fan air outlet, all along the sides of the case where the top and bottom panels meet, the I/O expansion slots at the back of the PC, and the front of the PC where there used to be a large five-and-a-quarter-inch hard drive. (I've since upgraded to an IDE hard drive, so this spot is empty—there is just a big hole there now, covered by a plastic snap-on panel.)

Again, where I work, we measure the electrical resistance between various parts of the products we manufacture. We typically specify that the bonding resistance be less than 2 milliohms—that's .002 ohms. I measured the resistance between the top and bottom panels at several ohms. This resistance changed value as I lifted the lid on my flip-top case, indicating that the bond between the top and bottom was very poor.

Between the drive bay (the bracket that holds the floppy drives) and the bottom panel, I measured an open circuit. The I/O expansion bracket that holds the plug-in cards was totally isolated from the bottom panel. The fan outlet is a big hole to RF since the fan is made of plastic and so doesn't block any RF. Likewise for the big hole that used to hold the hard drive. What I had was a bunch of floating metal panels

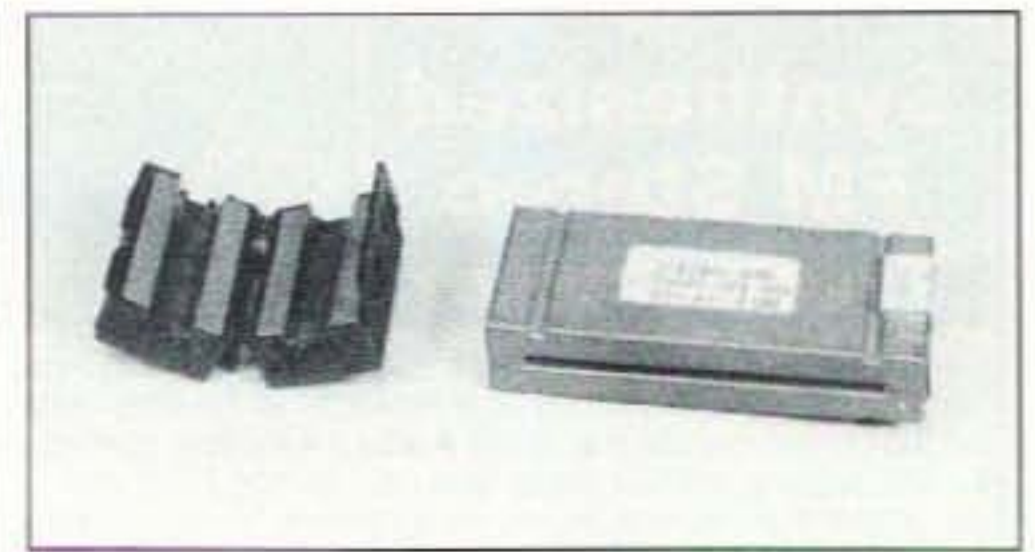

Photo A. Clamp-on ferrite filters are sometimes quite effective, but didn't help my PC.

that were not connected to anything! You don't need a probe like the one I used to clean up your PC—just follow my instructions and you should be able to do it quite easily.

The following parts and tools will be needed to complete the job:

- wrist strap for preventing static damage to the sensitive motherboard and plug-in cards

- screwdriver or small nutdriver socket to fit the metal tapping screws

- electric hand drill

- rotary wire brush for the hand drill

- set of small-diameter drill bits

- ohmmeter that can resolve resistances down to 0.1 ohm (most DMMs should work fine)

- sheet aluminum approximately one-sixteenth-inch thick (a few pieces)

- metal shears to cut the sheet aluminum

- 2 ceramic disc capacitors, 0.01 μ F 1,000 V

- 1 miniature DPDT toggle switch rated at 250 VAC, two amps or better

- an assortment of metal self-tapping screws

- 1 ferrite/iron toroid core, about one inch inside diameter

- 1 five-inch-square piece of metal window screen

- 10–15 sets of 6-32 x 1/4-inch screws, 6-32 nuts, and size 6 external or internal star washers.



Photo B. EMI engineers use a probe like this to sniff out interference.

What you are going to do is create an RF-tight case. The case must be as near one solid piece of metal as possible. All parts must have good electrical contact with each other. When two panels contact each other for a long distance, you will need to provide several points of metal-to-metal contact. All large holes must be covered with metal plates or metal screen.

First things first

Begin by making a map showing where *all* the cables and connectors go. Note which way the ribbon cable connectors go on—most will fit either way. Mark each of the cables with a small dot of paint or marking pen, then make a similar dot on your map. See **Fig. 3**. Now go back and re-check the diagram against the PC itself.

Next, pull the AC cord from the PC and the wall. Then get a static strap so you don't zap any of the parts when you slide around in your chair and build up a nice healthy charge. Its function is simple: It drains all the charge from your body to the PC chassis through the wire and resistor instead of through the ICs. (This is also a good tool to have whenever you replace boards, add RAM or other times when you have your hands inside the PC.) Before touching anything inside, put the band around your wrist. Then connect the alligator clip to the power supply case. (Since I had a floating case, I had to pick some point as ground. The power supply had to be connected to all the electronic parts, so I chose it for the ground connection.) You will need to completely disassemble your PC down to the major component level. Remove the disk drives, power supply, plug-in cards, and motherboard.

When removing the power connectors from the motherboard and disk drives, be very careful not to apply too much twisting force—you could damage the circuit boards. The power connector on the power supply cable must be tilted away from its mate on the motherboard and then pulled straight up. Practice on a junk board if you've never done it before, or get some help from someone who has. Likewise, in

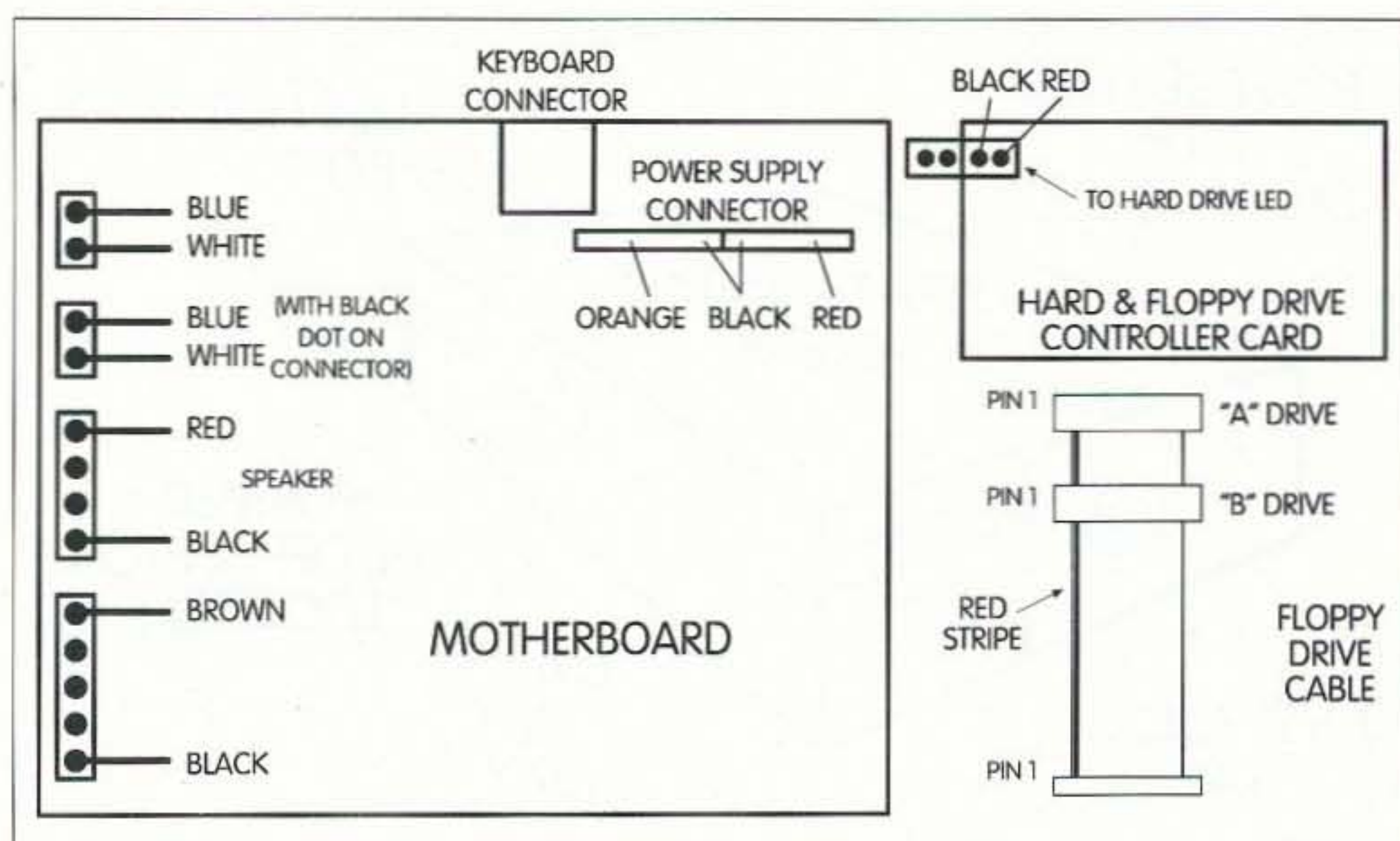

Fig. 3. Draw a diagram of your PC's hookup before disassembly.

reassembling the PC, use minimal force when plugging in the power connectors to the motherboard and disk drives.

Next take the case completely apart, including all panels and brackets that attach to each other with screws. My case is a flip-top that uses screws to hold the drive bay and I/O expansion bracket (located at the back of the PC) to the bottom of the case.

Power supply

Next we'll modify the power supply. Mine had a large red plastic bat-handle on/off switch on the side (see **Photo C**). I removed it and covered the hole with a piece of aluminum. (I measured a lot of leakage at this point, but I'm not sure that this size hole would allow 137 MHz energy to escape. It could have just been leaking out of the gap between the top and bottom panels right next to this switch.) Measure the resistance between the new aluminum plate added here and the power supply chassis, making sure you have a good connection.

Remove the voltage selector switch (see **Photo C**) and solder together the wires that the selector switch used to short together. In its place, mount a miniature DPDT toggle switch; it will be the new power on/off switch. The new switch plugs the hole nicely. I doubt that any RF would leak out here, but plugging it can't hurt. At the 115 VAC input connector, bypass both

lines to ground with the .01- μ F capacitors, using short leads. Make sure the capacitors' leads have a good, low-resistance connection to the power supply chassis.

While you have the power supply apart, vacuum it out. Most will have some dust inside, and some will have a lot of dust. The power supply will run cooler if the components don't have a blanket of dust to insulate them.

Remove the fan, noting which way it is mounted. When you replace it, you want the air to exit the back of the PC. If there is a stick-on label near the center, peel the label back and put a few drops of light oil on the shaft. Some fans I've seen also have a rubber plug that must be removed to get access to the shaft. Seal it back up with the label



Photo C. The large plastic on/off switch was removed, and the hole sealed with an aluminum plate. The 120/240 VAC switch was removed and its wiring was bypassed, and the new on/off toggle switch was mounted in its place.

ALL ELECTRONICS CORPORATION

8 Inch 4 Ohm Woofer

Heavy-duty 8" 4 ohm woofer with coated paper cone, poly foam surround and foam rubber front gasket. Good looking speaker, with blue basket. 1.25" voice coil, 3.5" deep. Approximately 13 oz magnet. 40/60 watt peak. 2.9 lbs.
CAT # SK-841



\$8.50 each

Equipment Knob

Alcoknob # PKG90B1/4
 0.86" dia. X 0.56" black molded phenolic knob with brushed aluminum face. Ribbed body with indicator line. Brass insert with two set screws. Fits 1/4" full round shaft.



CAT# KNB-74

25 for \$16.25
 100 for \$50.00

2 for \$1.50

SL WABER "PowerMaster" Surge/Noise Suppressor

Protect your computer, phone, VCR, TV and stereo equipment from damaging transient voltage surges. Just plug in, and you've got full 3-line protection. Visual indicator lets you know that the device is functioning. UL, CSA listed.



CAT # PW-103

\$2.75 each

S-VHS Video Tapes

Name-brand S-VHS, T-120 tapes. Used for a short time, then bulk-erased. The record-protect tabs have been broken out, so you will have to cover the notch with a piece of tape. They work great.



CAT # S-VHS

\$3.00 each

10 for \$28.00
 100 for \$250.00

ORDER TOLL FREE

1-800-826-5432

CHARGE ORDERS to Visa, Mastercard, American Express or Discover

TERMS: NO MINIMUM ORDER. Shipping and handling for the 48 continental U.S.A. \$5.00 per order. All others including AK, HI, PR or Canada must pay full shipping. All orders delivered in CALIFORNIA must include local state sales tax. Quantities Limited. NO COD. Prices subject to change without notice.

CALL, WRITE FAX or E-MAIL for our **FREE** 96 Page CATALOG Outside the U.S.A. send \$3.00 postage.

MAIL ORDERS TO: ALL ELECTRONICS CORPORATION P.O. Box 567 Van Nuys, CA 91408 FAX (818)781-2653

e-mail allcorp@allcorp.com
 internet - <http://www.allcorp.com/>

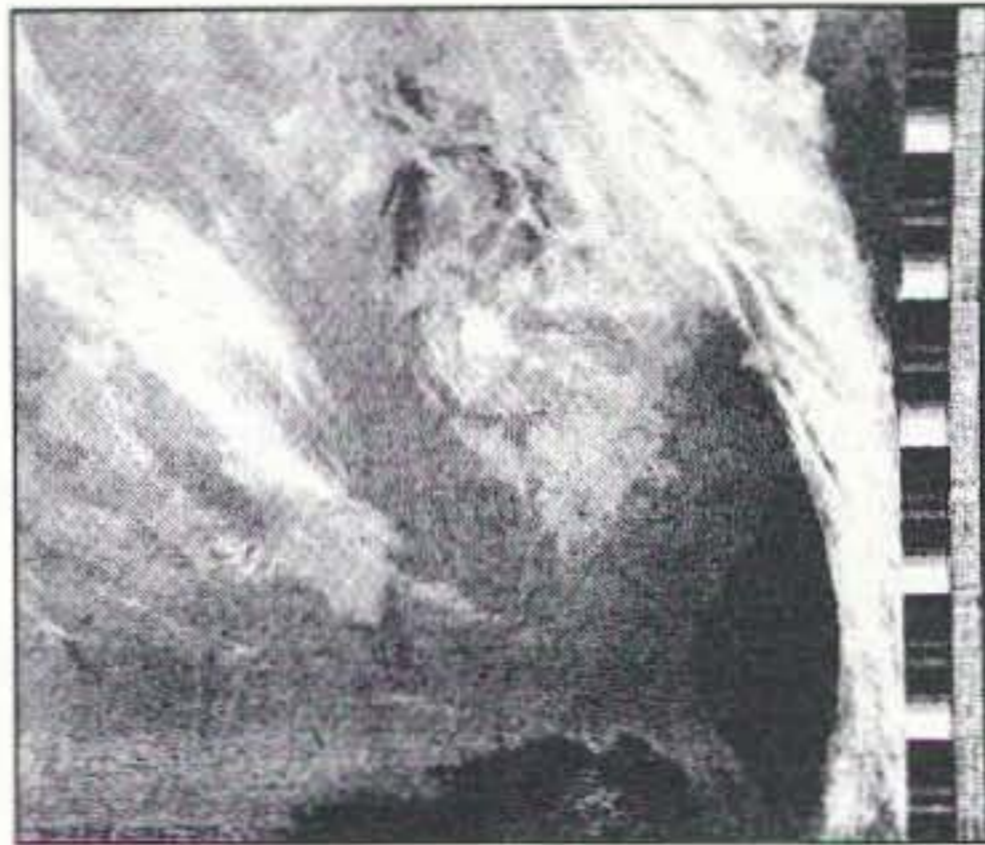

Photo F. Still another image from a NOAA weather satellite.

and rear panels of my PC are steel, so I had to select the drill bit sizes properly.

That's all you should have to do to make your case RF-tight. Remember to take your time, and make good notes and diagrams showing where everything goes *before* you remove anything.

Problems

I know you don't want to take apart your PC. After all, it does work properly and you might screw up something. Also, it does look nice. But remember, you can't hear those weather satellite or packet signals clearly! Proceed carefully while making the changes and clean up that noise!

There are several problems with these modifications. First, the PC won't look as nice as before since there will be some paint missing where the screws bind the top to the front and rear panels and the top and bottom panels together. Buy some matching touchup paint and go over the spots where you removed the paint.

Another problem is that it will take more work to replace cards, since you have to remove so many screws to get to the inside. Also, the threads in the panels will eventually strip after the screws have been removed/replaced a few times. This can be minimized by starting the screw by hand to make sure it engages with the thread already in place rather than starting a new one each time you put the screw back in place. My advice is to plan your

changes carefully and make several changes at once if possible, or if you're unsure of a change, test it before you put the case back together.

I've included weather satellite pictures showing the quality of the pictures after the modifications (Photos D, E, F). I didn't bother saving any pictures with the noise in them, so I can't show you how bad they actually were. The pictures before modifications had two or three lines of noise (no picture data) every 10 to 20 seconds whenever the program wrote data to the hard drive. I wanted to show how bad the pictures used to be, so I removed the top of the case and began digitizing a satellite pass. To my surprise there was no interference in the receiver! Now I couldn't *force* the PC to interfere! Maybe you won't have to drill any holes in your case top/bottom to silence it. Try all the changes except for drilling holes in the case to see if that is adequate for your PC.

Other people have PCs similar to mine and don't have interference. Maybe I had a very noisy motherboard, an exceptionally leaky PC case, a bad antenna location, or the combination of all these. The bottom line is that I eliminated the noise and I learned a lot in the process.

By the way, you might keep this article handy. In the future, PC microprocessor speeds are only going to go up and the holes in your case that don't leak EMI now will let the higher frequencies right through! Microprocessors are running at 233 MHz in the new PCs now, with speeds twice that high probably not more than a few years away. The techniques in this article may help you later if you have problems with EMI.

If you make these changes to your noisy PC I would be interested in hearing from you. I'd like to know how it helped or if it didn't. Good luck—and go slowly when making the modifications. Remember, too, that tampering with your PC might void its warranty if there is one—be sure to check this if it matters to you.

And finally, many thanks to my wife for helping review this article and to

Earn cash for your cover shots.

Send to Joyce Sawtelle at 73 Magazine
 70 Route 202N Peterborough NH 03458



NO POSTAGE
NECESSARY
IF MAILED
IN THE
UNITED STATES

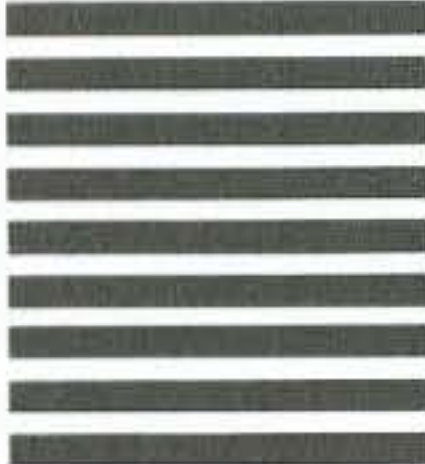

BUSINESS REPLY MAIL
FIRST-CLASS MAIL PERMIT NO. 4474 COLUMBUS, OH

POSTAGE WILL BE PAID BY ADDRESSEE

ELECTRONICS BOOK CLUB®

A Division of The McGraw-Hill Companies



P.O. Box 182600
Columbus, OH 43272-3027



SELECT **5** BOOKS FOR ONLY **\$4.95**

when you join the

Electronics Book Club[®]

YES! Rush me the following titles, billing me just \$4.95 plus shipping/handling & sales tax. Enroll me as a member of the **Electronics Book Club[®]** according to the terms outlined in this ad. If not satisfied, I may return the books within 10 days and have my membership cancelled. I agree to purchase just 2 more selections at regular club prices during the next 12 months and may resign anytime thereafter.

Code #'s of my books for \$4.95

--	--	--	--	--

If you select a book that counts as 2 choices, write the book number in one box and XX in the next.

Name _____ Signature _____

(Required on all orders)

Address/Apartment _____

City _____ Zip _____ Phone _____

Valid for new members only, subject to acceptance by EBC. Canada must remit in U.S. funds drawn on U.S. banks. Applicants outside the U.S. and Canada will receive special ordering instructions. A shipping/handling charge & sales tax will be added to all orders. © 1998 EBC

STAR498

ELECTRIFY Your Library when you join EBC

GET 5 Books FOR ONLY \$4.95



1557350 \$19.95



912979X \$39.95

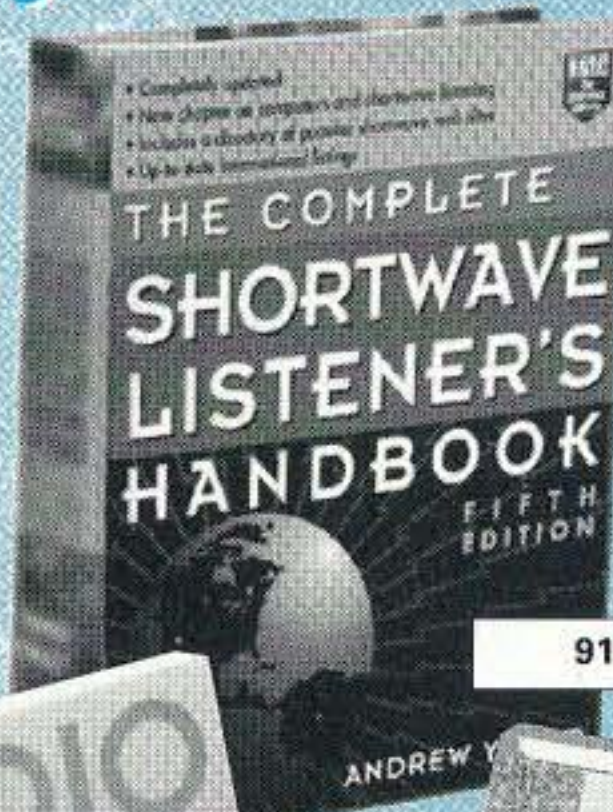

9130100 \$29.95



0156417 \$21.95
Hardcover

Values to
\$234.80



0235619-XX \$50.00
Hardcover/Counts as 2

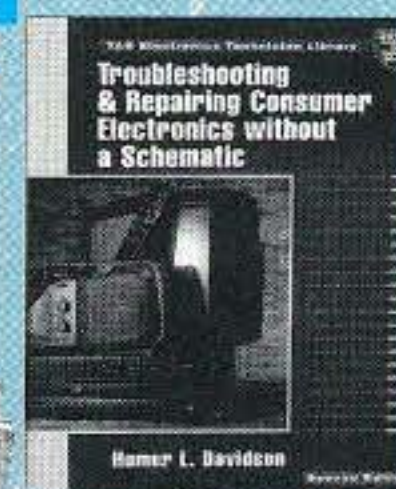

0157642 \$44.95

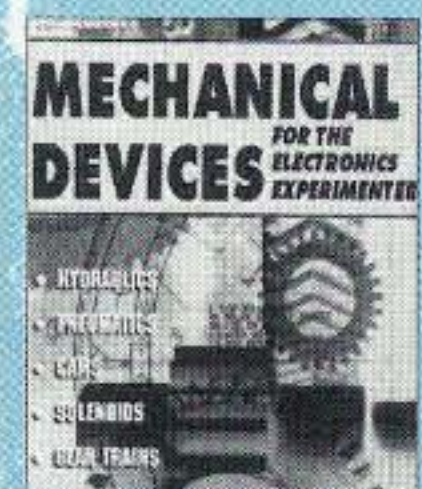

0535469 \$29.95
Hardcover

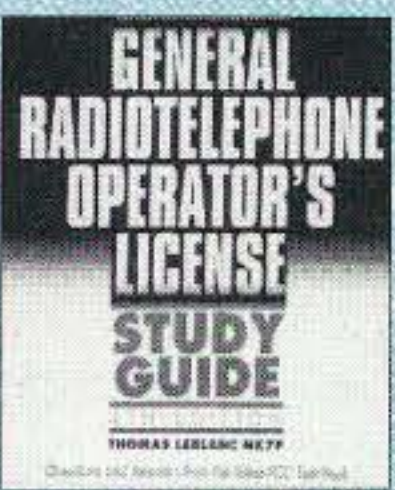

0369364 \$29.95
Hardcover

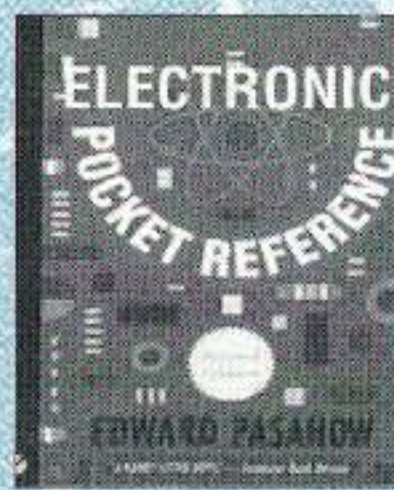

0487375 \$24.95

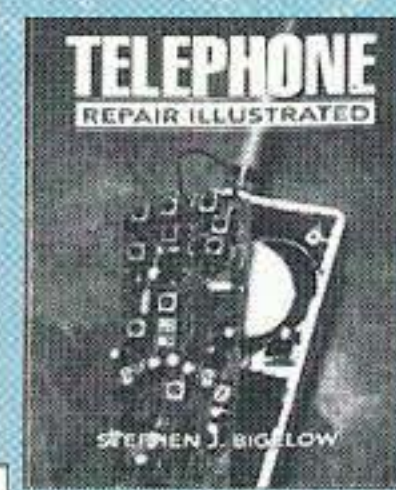

0052387 \$28.95

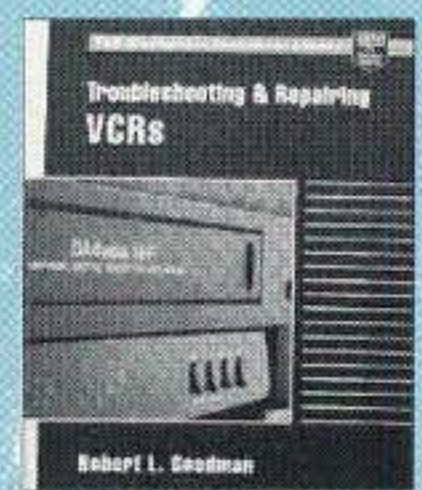

0241996 \$44.95

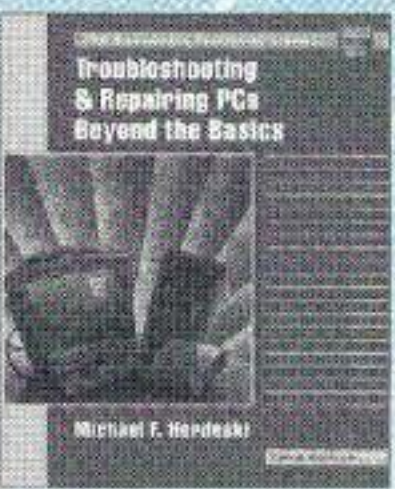

0305552 \$44.95



0350787-XX \$44.95
Hardcover/Counts as 2

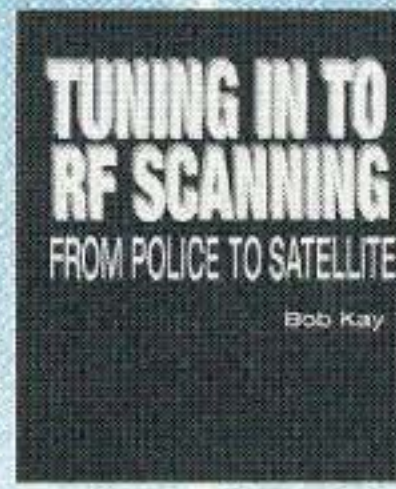

0339635 \$24.95



0765359 \$34.95



0650780 \$27.95



0304084 \$26.95

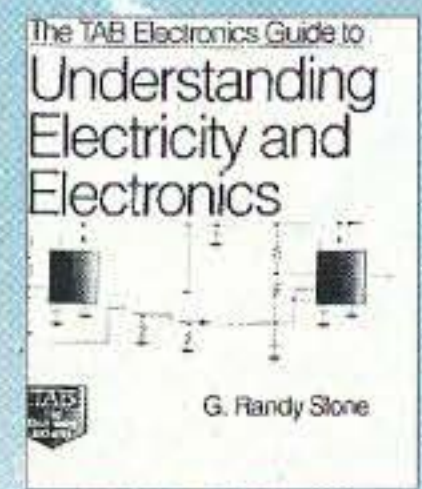

0582157 \$26.95
Hardcover



0304068 \$17.95



0365946 \$24.95



1574875 \$19.95

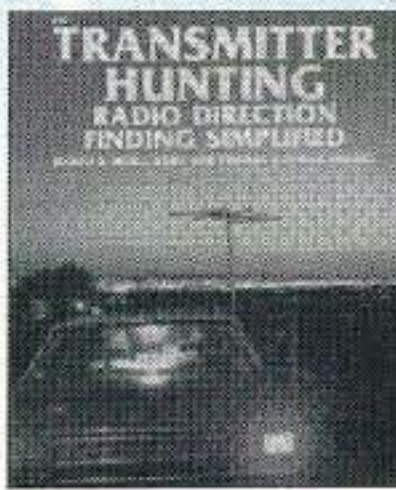

1560068 \$24.95

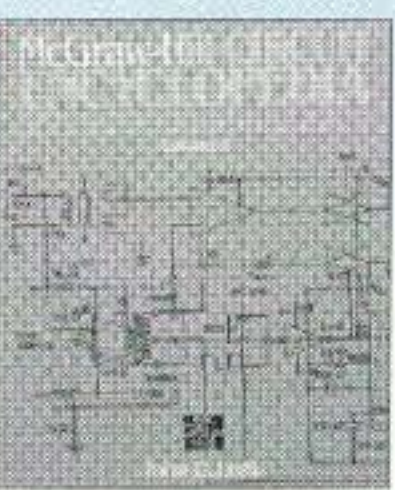

0380767 \$39.95

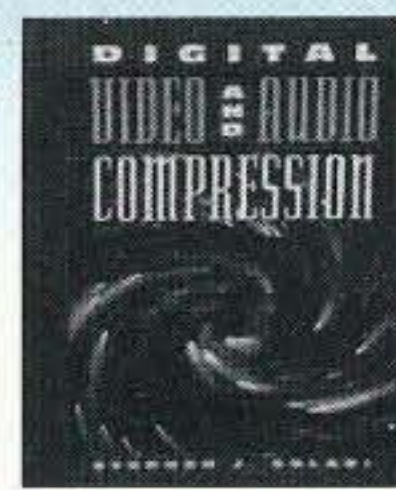

0595380 \$55.00

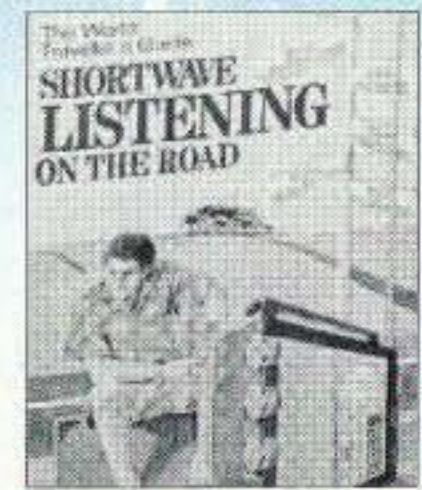

076509X \$17.95

As a member of the ELECTRONICS BOOK CLUB...

you'll enjoy receiving Club bulletins every 3-4 weeks containing exciting offers on the latest books in the field at savings of up to 50% off the regular publishers' prices. If you want the Main Selection, do nothing and it will be shipped automatically. If you want another book, or no book at all, simply return the reply form to us by the date specified. You'll have at least 10 days to decide. If you ever receive a book you don't want due to late delivery of the bulletin, you can return it at our expense. Your only obligation is to purchase 2 more books during the next 12 months, after which you may cancel your membership at any time. And you'll be eligible for FREE BOOKS through our Bonus Book Program.

A shipping/handling charge and sales tax will be added to all orders. All books are paperback unless otherwise noted. Publishers' Prices Shown © 1998 EBC

If card is missing, write to:
Electronics Book Club®
A Division of The McGraw-Hill Companies
P.O. Box 549, Blacklick, OH 43004-0549

Electronics Book Club®

A Division of The McGraw-Hill Companies

YES! Please send me the books listed below, billing me just \$4.95, plus shipping/handling & tax. Enroll me as a member of the EBC according to the terms outlined in this ad. If not satisfied, I may return the books without obligation and have my membership cancelled. I agree to purchase just 2 more selections at regular Club prices during the next 12 months and may resign anytime thereafter.

--	--	--	--

If you select a book that counts as 2 choices, write the book number in one box and XX in the next.

Name _____

Address/Apt. # _____

City/State _____ Zip _____ Phone _____

Valid for new members only, subject to acceptance by EBC. Canada must remit in U.S. funds drawn on U.S. banks. Applicants outside the U.S. and Canada will receive special ordering instructions. A shipping/handling charge & sales tax will be added to all orders. STAR498

Modifying Your Ramsey Transceiver Kit

One step closer to the ultimate ham experience!

Peter A. Bergman NØBLX
3517 Estate Dr. SW
Brainerd MN 56401

Kit building is fun; you start with a proven design and a good set of directions, you get to satisfy your creative urges, you don't need a junk box the size of Arizona—and when you finish you have the device you wanted, but you *don't* have a bunch of leftover stuff you didn't need in the first place. Been there, done that ... and I suppose if God lets me live long enough, I'll use it all some day.

Scratch building is a lot of fun. Some folks claim it is the ultimate ham experience. Modifying a kit you've built is a step closer to that ultimate experience.

When the subject of kit building is raised, somebody is bound to mention the boys from Benton Harbor—they

aren't in the ham radio kit business anymore, though their kits were a lot of fun and are still generating modification articles. However, now we have several other companies producing a wide variety of ham radio-related kits. Ramsey Electronics is one of those companies.

I've built a number of kits, and the Ramsey FX-146 is one I use every day. The FX series of FM transceivers includes units for the 50, 146, 220, and 440 MHz bands. These rigs are diode-programmed, with a "box-stock" 12-channel capability.

The diode programming may sound a little primitive, but it has definite advantages for a mobile operator like myself. My job requires that I be on the road at all hours in all kinds of weather. The simplicity of operation found in a rig like the Ramsey FX lends itself to that environment.

Some forethought is required when choosing frequency pairs. This led me to explore methods of adding to those 12 channels. One of these methods was described in an article in the January 1997 issue of 73. After using my modified FX for awhile, I decided it would be really nice if it had

a -600/simplex/+600 switch. It took longer to figure out how to add that feature than it did to install it.

Having very little formal electronics training, it took me a while to realize that it doesn't matter how a programming line gets turned on. I'd been thinking I'd have to switch the offset diodes for each programming line. Anybody have a 12-pole, three-position switch? That will fit inside my FX? Cheap?

All that is actually required is a single-pole, three-position switch and three each 1N914 or equivalent diodes. If you are worried about a world shortage of 1N914s, you could get by with a single diode. I prefer the redundant approach. If one of the diode switching lines fails, I'll still have two possibilities to use.

There is room for a reasonably-sized switch on the front panel between the squelch control and the channel switch. Once the switch is mounted, remove all the +repeat, -repeat, and simplex diodes from the matrix. Install 1N914 or equivalent diodes in the extra programming line at the +RPT, -RPT, and SIMP positions. Then run a lead from each of them to one of the positions on

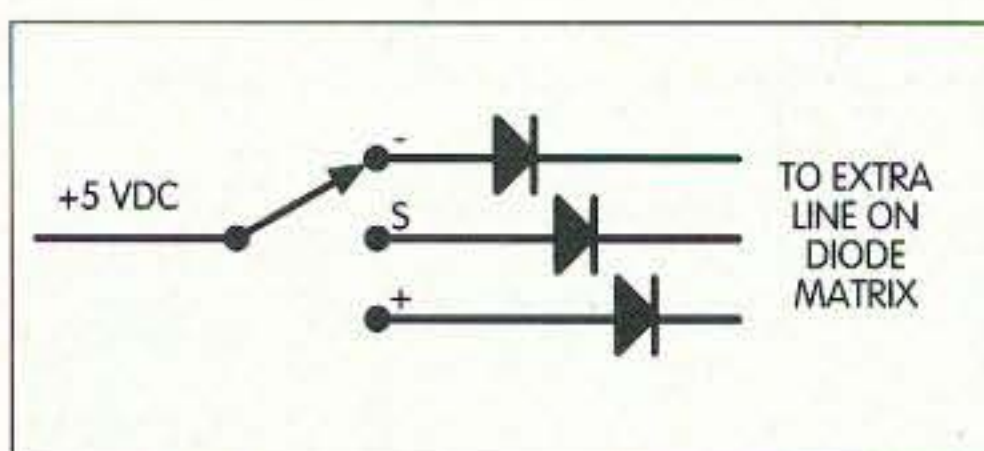

Fig. 1. Offset switch: Remove all other minus, simplex, and plus diodes from matrix. Pick up 5V from front center of board.

the switch. Minus, simplex, plus seems to be a pretty common arrangement, but there is no hard-and-fast rule, so do what seems best. Connect a short lead from the +5-volt pad on the front edge of the board to the switch wiper, and you're in business. (See Fig. 1.)

Adding this feature greatly increases the operating flexibility of the FX rig. During emergency or public service operations, it is not uncommon to find the repeaters and "standard" simplex frequencies all in use. Choose an unoccupied repeater output frequency and use it simplex. Some repeater outputs are used with either a plus or a minus input, depending on where the repeater is located. For example, 147.030 uses a plus offset here in Brainerd, but a minus offset in Wilmar, Minnesota, and Sedalia, Missouri.

This modification is easy to install and will work on any of the FX-series rigs, so give it some thought. On the other hand, things get a bit more complicated if you are using the auxiliary line to provide a nonstandard offset.

The aux line is turned on through a diode connected to the back end of the appropriate diode bridge. If you follow the suggestions given above, strange things are likely to happen when you switch to the channel using the nonstandard offset. Suppose you have the Civil Air Patrol frequency of 148.15 with its minus 4.25 MHz offset in one of the channels and ham repeaters in all the others. When you turn to the CAP channel the aux line will be telling the processor to do one thing while the plus-simplex-minus switch is telling it to do something else. I have no idea where the output will actually be. Something must be done—unless you want calls from the FCC ... or, conceivably, the Pentagon.

From the operator's point of view, the simplest solution is to use a two-pole switch with four or more positions. When the aux line is turned on, everything else in the matrix must be turned off to prevent unpredictable frequency excursions. That is why a two-section switch is needed (see Fig. 2).

The first three or however many positions of section A select the standard

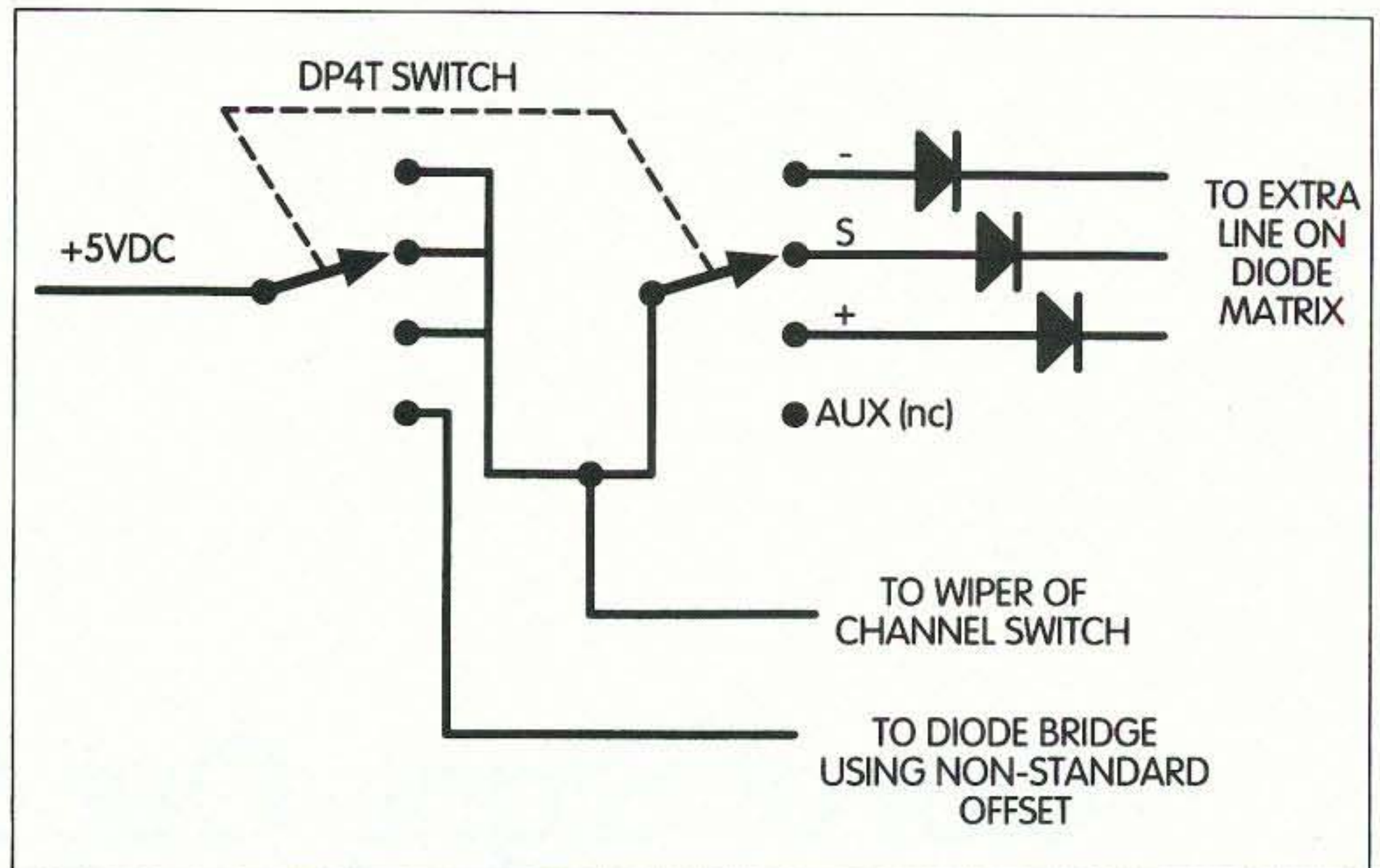

Fig. 2. Control arrangement when using nonstandard and standard offsets.

offsets or simplex. The last position on section A is not connected. The last position of section B will turn on the diode bridge connected to the auxiliary offset line. Tie the other positions of section B together and use them to feed five volts to the wiper of section A and the wiper of the channel switch. This will free a position of the channel switch, allowing a 13th frequency to be programmed. There is already room on the matrix, so we might as well.

If your junk box doesn't produce a two-pole, four-position switch, try Radio Shack™ #275-1386A. It's a two-pole, six-position switch, but you can cross-connect some of the positions. An arrangement like plus, minus, simplex, plus, minus, auxiliary works fine.

After I had reached this point, I decided I needed some sort of indication of the offset switch position. I wanted it simple and easy to read, at a glance, in the dark. I had already installed a bi-color LED so that it was green at channel one and red on the non-ham frequency. I figured a couple more LEDs wouldn't hurt. I arranged two T1s and a rectangular LED like a "divided by" symbol. The horizontal rectangular LED indicates a minus offset; the double dots indicate a plus. When the bicolor turns red, I'm on the non-ham frequency. There is probably a more sophisticated way of doing it, but this works.

Now that I have this mod working, I wonder if I have room for a plus 5 kHz switch. Hmmm ... 73, NØBLX. 73

NEW for ham radio operators!

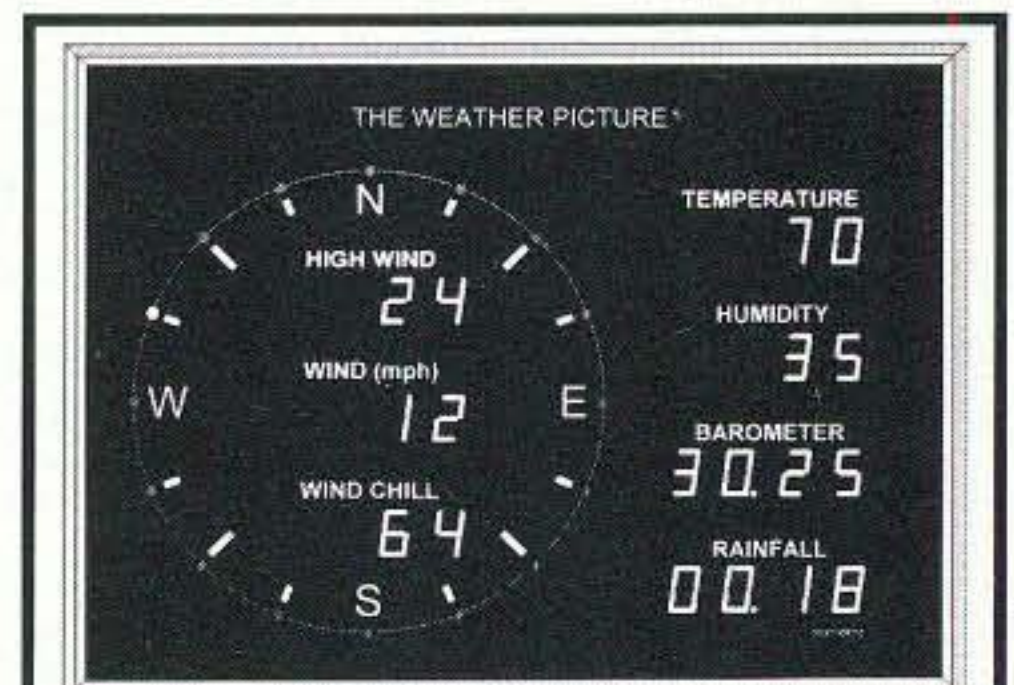

Size shown: 15 1/4" x 11 1/4"

Put the weather on your wall

The Weather Picture™ is an eye-popping new wall unit that continuously displays all the vital weather data you have selected, without having to press a single button. Big red numerals are easy to read from across the room, day or night. Available in two sizes, in brushed aluminum or elegant solid teak frame. The separate control unit provides detailed data—more than enough to satisfy even the most dedicated weather buff.

Purchase the Weather Picture together with the incomparable ULTIMETER® Weather Station, starting at under \$400. Or add it to your existing ULTIMETER System for less than \$150. It's easy to add programmable display modules to The Weather Picture now or later as needed.

For complete details, call toll-free, fax, or write us. Or visit our Web Site to see and try our ULTIMETER Systems. "The best!" says *WeatherWatch* magazine (5/96).

1-800-USA-PEET

or 732-531-4615 FAX: 732-517-0669

www.peetbros.com

©PEET BROS COMPANY

1308-8047 Doris Ave., Ocean, NJ 07712

Out of Sight, Out of Mind

Discretion is the better part of neighborhood amity. Part 2: hardware.

Kevin Scott WB4BNU
1939 McLennon Court
Lawrenceville GA 30043

In Part 1, we went over ideas for putting an antenna system together in places that don't allow for a "visible" antenna. Here, in Part 2, we'll review a camouflaged multiband remote-tuned vertical antenna that I put together and am now using successfully. I was really amazed when I turned on my rig to 160 meters one night and discovered a contest in progress. I am usually not a contester, but here was a good opportunity to work on my WAS and to test my new antenna at the same time. In that one contest weekend, I worked over 35 states!

There are three major parts to this antenna—as with most designs, especially verticals: the ground system, the radiating element of the antenna itself, and the remote tuner. The first two were mentioned in Part 1 of this article, but we will briefly review them again here.

Ground system

For my setup, I placed eight to 10 runs of 12-gauge insulated solid copper wire on the ground running out radially from a proposed future antenna site. This was done just before I put

down the sod in my back yard, which turned out to be a lot easier than burying wire in an existing lawn. Besides occasional tripping over the radials while putting down the sod, the extra effort was minimal. I soldered all the radials together at the middle to finish things up. Some of these radials are 100 feet while others are about 40 feet. The results on 160 and 80 meters, so far, have shown no perceivable directional characteristics of the radiation pattern of my antenna because of the asymmetrical radial placement. It may not be a broadcast AM station setup with 120 quarter-wave radials, but it works for me.

Antenna's radiating element

In the "Commandments" section of Part 1 of this article, I urged, "If you have trees, use them."

To get an antenna wire up in a tree where I want it, I use the following materials and method. First, the materials:

- a hunting slingshot,
- a half-ounce lead weight,
- a fishing pole with eight-pound test on a spincasting reel,
- and nylon twine.

Now the method: Attach the lead weight securely to the end of the fishing line. Make sure the pole is aimed at the spot where you are shooting and mounted firmly so that the line moves freely. Load the slingshot with the lead weight, aim and shoot (but don't aim near your neighbor's windows in case the weight comes off the fishing line). Once the lead weight and the fishing line fastened to it have reached the ground (you may have to coax the weight down by giving the line some slack from the fishing pole, and shaking it if necessary, depending on tree branches and foliage), remove the weight and tie the nylon twine onto the end of the fishing line. Knot-tying from Boy Scouts has proved invaluable for making streamlined knots that resist getting hung up around the branches (the sheet bend knot works best). Now, go back to the reel and wind in the line until you reach the nylon twine. With twine in hand, you should be able to hoist just about any size wire you want to use.

Next, camouflaged green Dacron™ rope is tied to the nylon twine and pulled back through. Attached to the rope is the antenna wire. This Dacron

rope is chosen to support the other end of the antenna wire as well as to blend in with the natural foliage. Also, since the nylon twine is fairly visible, I certainly do not want it to be used as an antenna support and give away my "secret." Using this method, I was able to get an antenna wire over the highest branch of the tallest tree in my backyard. This took many attempts since there was a light breeze blowing the fishing line away from the tree, or to a different branch, but patience paid off. This system using the slingshot and more as described above has worked wonderfully throughout the years, although I occasionally do get puzzled looks from my neighbors.

For the vertical antenna, the radiating section is an insulated and spray-painted (several camouflage colors) 20-gauge multi-stranded wire (one side of a zip cord split in two) that runs to the top of the tree (55 feet) and loops back down again. Each end was soldered together at the base and connected to the antenna tuner input. This loop configuration gives the antenna a little larger capture area than if the wire had just been run to the top and had a support rope coming back down on the other end.

Remote antenna tuner

Many articles I have read about remote antenna tuners virtually require the reader to have a machine shop, or at least have a varied assortment of gears and motors. For me, this is too much effort, especially since I am not loaded with tools like Tim Taylor on *Home Improvement*. However, I do have a soldering iron and a modest assortment of electronics tools, so when I received a catalog supplement from Fair Radio Sales with a commercially-built remote HF antenna tuner for \$30, I knew I had to check into this further. Much to my surprise, this tuner was a real gem and a bargain. They also offer the same tuner without the roller inductor for \$17. Since my design does not use a roller inductor, this tuner would be ideal. If you want a roller inductor for another future project, then get the \$30 tuner. A roller inductor of this quality purchased by itself would

Original Tuner Connections (as received from Fair Radio)

RF Switch Position #	S1A Connected To:	S1B Connected To:
1	24th turn from bottom of L2	L2 bottom tap
2	top of L2	L2 bottom tap
3	18th turn from bottom of L2	L2 bottom tap
4	position 2 of S1B	S1A position 2 (shorts coil to ground)
5	C27 rotor	C27 stator
6	15th turn from bottom of L2	L2 bottom tap
Com	vacuum cap connection and to L1 roller inductor	external connection

Table 1. Original tuner connections (see Parts List for Fair Radio parts numbers).

cost you a lot more than the \$13 difference (see Table 4 for Fair Radio Sales part numbers).

Fig. 1 is a reverse-engineered schematic of the tuner as purchased—including the roller inductor that is available on the \$30 tuner and the vacuum variable capacitor (missing) that was on the original tuner. Depending on your needs and your antenna's impedance, you may be able to use one of the settings of the tuner as it is wired. However, to make this a multiband tuner, read on.

For my installation, I used a 55-foot vertical wire working against a ground radial system (described in Part 1). This antenna tuner works from 160 to 10 meters (excluding 12 meters for now). Most likely your system will differ from mine, but here are some helpful hints that should steer you in the right direction for

your unique antenna design and setup.

1. For 160 through 10 meters, if your antenna is longer than 55 feet but less than 66 feet: Reduce the inductance of the loading coil. Change the 80 meter tap to short out the loading inductor (not needed).

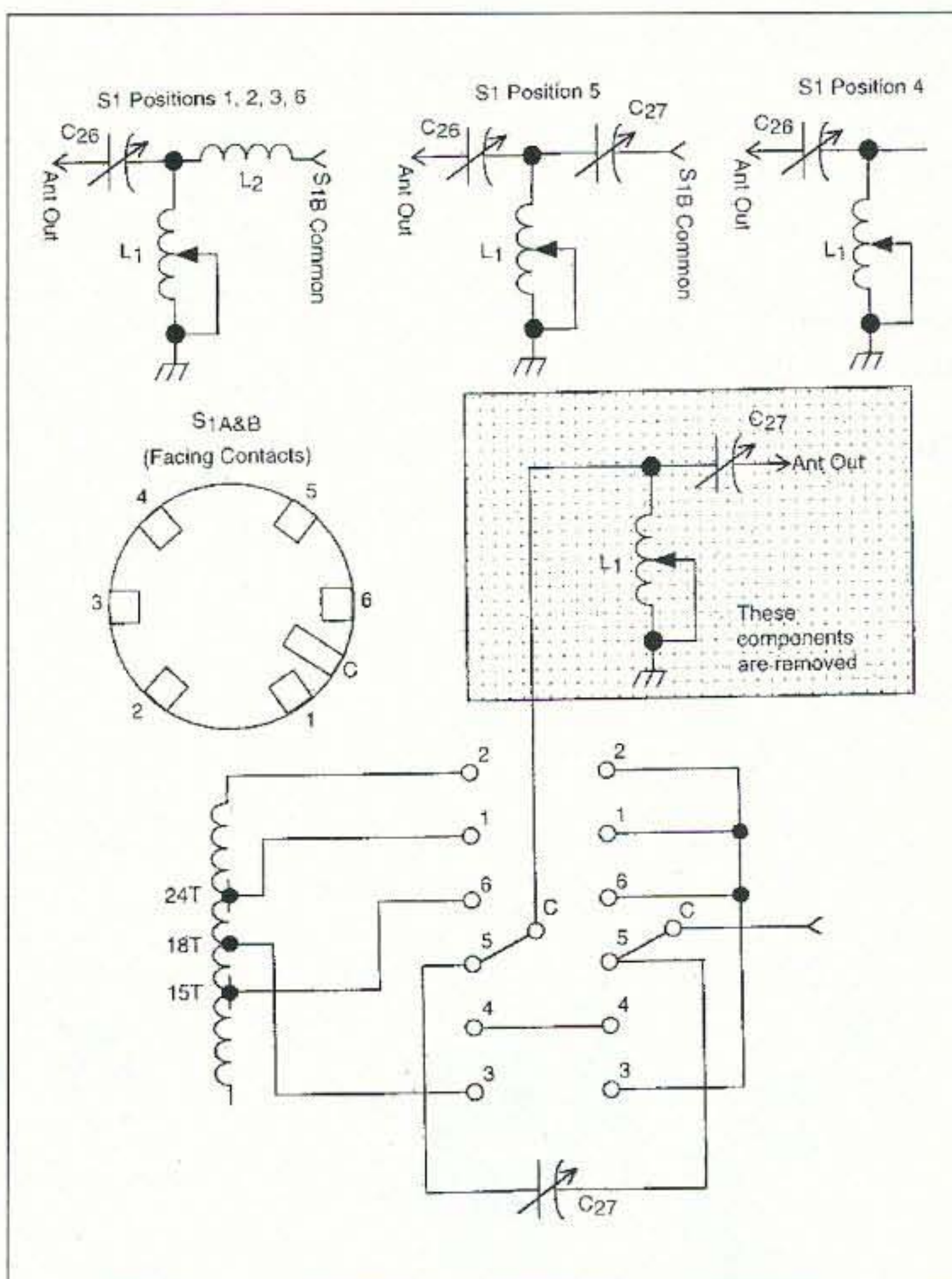

Fig. 1. Reverse-engineered original tuner diagram. L2 at bottom left.

If you are at the resonant frequency, the tuning capacitor should be able to dip your reflected power to near zero. If you are off, you may only be as low as 1.5:1, which is still OK. It depends on how picky you are about finding that perfect match point. With the right

match point, I found that the tuning range of C27 was sufficient to achieve a low SWR across each band. 160 meters was the only exception, although 80 was just barely 2:1 at the band edges (worse at the lower edge). The retuning of capacitor C27 is nec-

essary to operate across each larger band with a reasonable SWR level.

Tuning up (manual)

To test the tuner, you will need to connect power to it to run the servo motors as well as the external relays if you are using them. It is important that you clip both diodes mounted on the feedthrough caps if you want a bidirectional motor control. This makes tuning a whole lot easier. The motors are 24 volts but run well at 14 volts (from the radio power supply). I used short alligator clips for most of my "field tuning" when setting up the correct taps and for motor control. All work was done at the base of my antenna (sometimes in sub-freezing temperatures after dusk) to speed up the trial-and-error process of optimal tap finding.

The following is for 40 through 10 meters. 80/75 and 160 are explained at the end.

1. Connect your rig to J1 with an SWR meter in line.

2. Connect the antenna to be tuned to the antenna contact of K2.

3. Connect power to the motor driving S1A/B to rotate the switch to your desired band position as noted in **Table 2**. Remove power when you have reached the desired switch position.

4. Connect an alligator clip lead from the lug of S1A (from #3 above) to the appropriate tap on L2 (position as noted in **Table 2**).

5. Energize relay K2 or short it out, using very short alligator clip leads to approximate the true antenna length.

6. Set your rig to low power and transmit to get an SWR reading. While watching the reflected power, energize the servo motor that moves C27, and tune it until a dip in the reflected power is observed. If no dip is noted, then recheck your connections. You may also need to move the clip lead to another tap on L2 to find the resonant point of your antenna (trial-and-error). Once you have found the resonant tap, solder a wire from this tap to the appropriate solder lug on S1A.

Hint: If you have a variable cap that is equivalent in size and value to C27, you can speed up your tuning process by setting C27 at minimum capacity

Antenna Coupler Cross-Reference

J1 Connector

Pin	To feedthrough cap #	To rotary switch and position #	Tuning capacitor C27 rotor/stator plate condition	Connected to remote tuner control box?
1	C20	S2 - 5		Y
2	C21	S2 - 6		Y
3	C19	S2 - 4		Y
4	C16	S2 - 3		Y
5	C15	S2 - 2		Y
6	C6	S3 - 1	5/8 mesh	N
7	C7	S3 - 2	3/8 mesh	Y
8	C8	S3 - 3	1/4 mesh	N
9	C9/C10	S3 - 5	1/16 mesh	N
10	C9/C10	S3 - 5	1/16 mesh	N
11	C11	S3 - 4	1/8 mesh	N
12	C12	S3 common		Y
13	C13	S3 - 7	1/16 mesh	N
14	C14	C27/S3 motor B+		Y
15	C5	S3 - 10	7/8 mesh	N
16	C4	S3 - 6	edge of mesh	Y
17	C17	S2 - 1		Y
18	C18	motor B-		Y
19	C3	S3 - 11	full mesh	Y
20	C1	S3 - 12	7/8 mesh	N
21	C2	S3 - 9	3/8 mesh	Y
22	C22	S2/L2 tap switch motor B+		Y
23	C23	S2 common		Y
24	C24	originally unused (now K1 relay coil hot)		Y
25	C25	originally unused (now K2 relay coil hot)		Y

Other modifications: Connect top of L2 to stator of C27; connect rotor of C27 to ground.

Table 3. Clip diodes across motor windings to allow for forward and reverse direction of motors.

and connecting your substitute cap in parallel. Make sure that the rotor is connected to ground (same as the rotor of C27) and the stator of your capacitor to the stator of C27. Also, make sure that you have an insulated knob on the capacitor so you can tune it quickly by hand without getting RF burns. You should be able to find the SWR dip much faster and zero in on a minimum SWR.

7. Repeat step #6 for each band. Some bands will share the same tap. In my setup, 10 and 15 meters shared the same tap (although 12 meters did not tune properly), as did 17 and 20. 75 (phone section) and 80 meters (digital section) use the same tap, but this is a compromise to cover as much of the band as possible without having two taps for each subband. This was done because there weren't enough switch contacts available on S1A or B (unless you choose to eliminate 160 meters). To get full band coverage on 160 meters, position 6 is for the high end of the band, while in between any of the positions yields full loading inductance, to work the low end of the band. It's a sneaky way to get seven positions out of a six-position switch.

Remote control

The heart of this article is to design a *remotely controlled* antenna tuner—one that is also easy to build and operate. Most of the items used are available at Radio Shack™. Refer to **Table 2** for the reverse engineering of the DB25 connector and what is connected to each of its pins. I happened to have some surplus 12-pair telephone cable lying around, so I had the luxury of connecting nearly everything in the tuner to the shack's remote control box. If you want to keep it simple, use one to two runs of rotor cable (depending on the number of conductors) and connect the following as a minimum:

- 1—C27 B+
- 2—S1A/B B+
- 3—Motor B- (separate from ground)
- 4—K1 relay coil hot
- 5—K2 relay coil hot
- 6—S2 common

- 7—S2 position 1
- 8—S2 position 2
- 9—S2 position 3
- 10—S2 position 4
- 11—S2 position 5
- 12—S2 position 6

Switch S2 rotates with S1A/B and indicates which band position the switch is in. Without this feedback, you will have to guess which band you are on—which is not a good idea. It is well worth it to have the LED position indicators. The capacitor position indicators can be eliminated, if you don't have enough wire pairs, and especially if you don't care to know if the capacitor is moving. It should be obvious by the change in the SWR level during tuning.

Fig. 3 and **Table 2** are essential for correctly wiring your control box to the appropriate connection on the DB25 connector of the tuner, so refer to each of them regularly when wiring the system up. What I have listed in the connection scheme is a bit overboard for some, but I did have that long run of 12-pair jacketed phone wire at my disposal. I found that the 24-gauge wire used in the cable was more than sufficient to drive the motors from my shack, located over 75 feet away, with little IR loss—even running at 14 volts. Depending on what kind of wire you may have lying around, feel free to customize your own station setup. I do, however, recommend the minimum 12 connections as previously mentioned.

Note: In **Fig. 3**, the motor control common is tied together for both motors. I highly recommend that you rewire the tuner to split the motor common lines for each motor. This could be done easily by eliminating one of the LED indicator lines for C27 as wired on the tuner's feedthrough caps. As wired and shown in **Fig. 3**, if switches S4 and S5 were put in the wrong position at the same time, you would short B+ directly to B-. I didn't notice this until after I had completed this project and I have not had any problems, but I have been very careful, and I will be fixing my setup.

Continued on page 26



**THE BEST BATTERIES
IN AMERICA!**

SPRING '98 SPECIALS!

<i>Packs & Charger for YAESU FT-50R / 40R / 10R:</i>			
FNB-40xh Slim-NiMH	7.2v	650mAh	\$41.95
FNB-47xh (NiMH)	7.2v	1800mAh	\$49.95
FNB-41xh (5w NiMH)	9.6v	1000mAh	\$49.95
BC-601c	Rapid/Trickle Charger		\$59.95
<i>For YAESU FT-51R / 41R / 11R:</i>			
FNB-31 pack	4.8v	700mAh	\$31.95
FNB-38 pk. (5W)	9.6v	700mAh	\$39.95
BC-601b	Rapid/Trickle Charger		\$59.95
<i>For YAESU FT-530 / 416 / 816 / 76 / 26:</i>			
FNB-26 pack	7.2v	1200mAh	\$29.95
FNB-27s pk. (5w)	12.0v	800mAh	\$35.95
BC-601a	Rapid/Trickle Charger		\$59.95
<i>For YAESU FT-411 / 470 / 73 / 33 / 23:</i>			
FNB-10 pack	7.2v	600mAh	\$20.95
FNB-11 pk. (5w)	12.0v	600mAh	\$24.95
FBA-10	6-Cell AA case		\$14.95
BC-601a	Rapid/Trickle Charger		\$59.95
<i>Packs for ALINCO DJ-580 / 582 / 180 radios:</i>			
EBP-20ns pack	7.2v	1500mAh	\$29.95
EBP-22nh pk. (5w)	12.0v	1000mAh	\$36.95
EDH-11	6-Cell AA case		\$14.95
<i>For ICOM IC-Z1A / T22-42A / W32A / T7A:</i>			
BP-180xh pk.-NiMH	7.2v	1000mAh	\$39.95
BP-173 pk. (5w)	9.6v	700mAh	\$49.95
BC-601d	Rapid/Trickle Charger		\$59.95
<i>For ICOM IC-W21A / 2GXAT / V21AT: (Black or Gray)</i>			
BP-131xh (NiMH)	7.2v	1500mAh	\$39.95
BP-132s (5w)	12.0v	850mAh	\$39.95
BC-601e	Rapid/Trickle Charger		\$59.95
<i>For ICOM IC-2SAT / W2A / 3SAT / 4SAT etc:</i>			
BP-83 pack	7.2v	600mAh	\$23.95
BP-84 pack	7.2v	1200mAh	\$34.95
BP-83xh pk. (NiMH)	7.2v	1500mAh	\$39.95
BP-90	6-Cell AA case		\$15.95
BC-79A	Rapid/Trickle Charger		\$59.95
<i>For ICOM IC-02AT etc & REALISTIC HTX-202:</i>			
BP-8h pack	8.4v	1400mAh	\$32.95
BP-202s pk.	7.2v	1400mAh	\$29.95
IC-8	8-Cell AA NiCd/Alkaline Case		\$15.95
BC-350	Rapid Charger		\$59.95
<i>For KENWOOD TH-79A / 42A / 22A:</i>			
PB-32xh (NiMH)	6.0v	1000mAh	\$29.95
PB-34xh (5w-NiMH)	9.6v	1000mAh	\$39.95
KSC-14	Dual Rapid/Trickle Charger		\$64.95
<i>For KENWOOD TH-78 / 48 / 28 / 27:</i>			
PB-13T (w/ chg. plug)	7.2v	600mAh	\$23.95
PB-13xh (NiMH)	7.2v	1500mAh	\$39.95
BC-15A	Rapid/Trickle Charger		\$59.95
<i>For KENWOOD TH-77, 75, 55, 46, 45, 26, 25:</i>			
PB-6 (w/chg plug)	7.2v	600mAh	\$27.95
PB-8xh (5w-NiMH)	12.0v	1500mAh	\$49.95
KSC-14	Dual Rapid/Trickle Charger		\$64.95
<i>For STANDARD C-628A / C558A / 528A / 228A:</i>			
CNB-153xh pack	7.2v	1500mAh	\$32.95
CNB-152 pk. (5w)	12.0v	800mAh	\$32.95
CSA-181	Rapid/Trickle Charger		\$59.95
<i>For MOTOROLA GP-300 radios:</i>			
HNN-9628 pack	7.2v	1200mAh	\$39.95

Mr. NiCd also supplies batteries for your
**LAPTOP COMPUTERS / CELLPHONES
 CAMCORDERS / NiCd & NiMH INSERTS**
We can rebuild your Computer pack! Call!
 Mail, Phone, & Fax orders welcome! Pay with
MC / VISA / DISCOVER / AMEX

CALL OR WRITE FOR OUR FREE CATALOG!

Mr. NiCd - E.H. Yost & Company
 2211-D Parview Rd., Middleton, WI 53562
Phone: (608) 831-3443
Fax: (608) 831-1082
E-mail: ehyst@midplains.net

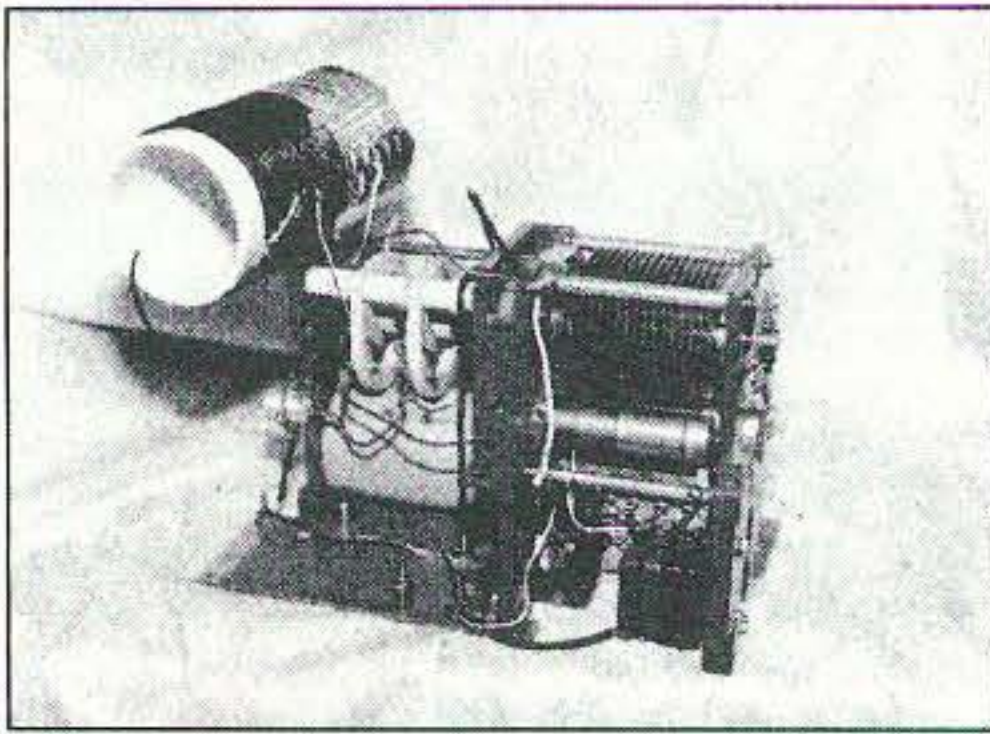

Photo D. Completed tuner assembly, front view.

Fig. 4 is used as a simple but functional layout for the remote tuner box and its associated switches and LED bar graph. If you have a better idea or have other junk boxes that you would prefer to use, then by all means do so. Be creative, but make it functional.

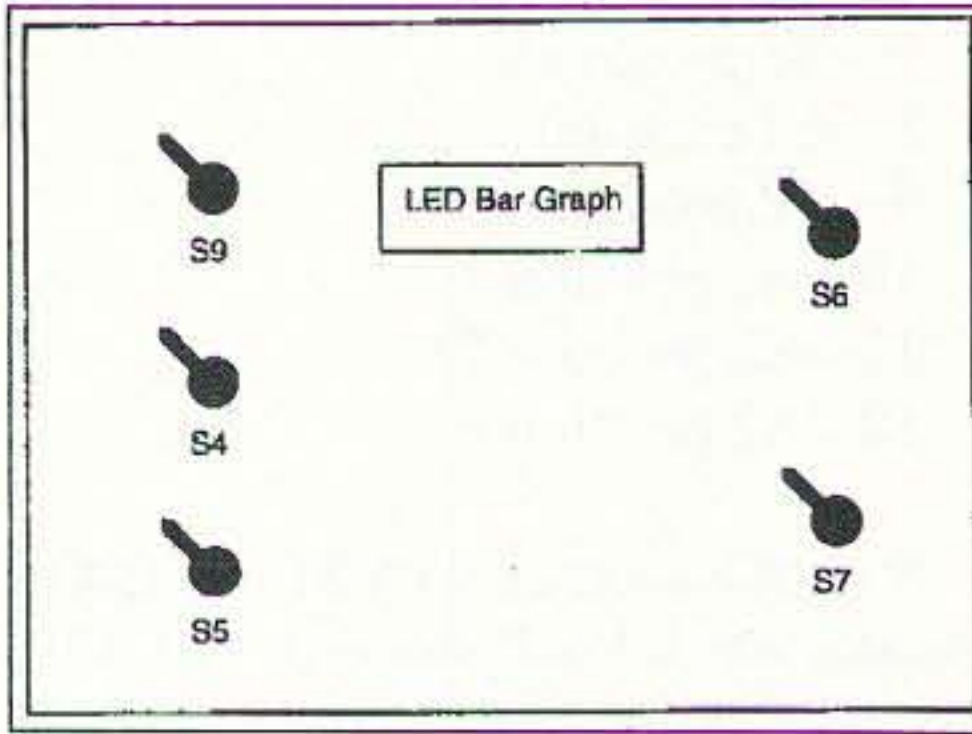

Fig. 4. Suggested panel layout for remote unit.

Outdoor tuner housing

Last but not least, you will need a box to put the tuner in to keep it out of the elements. Fair Radio Sales also has some good deals on enclosures, such as three Fiberglas™ ones for \$15 [readers should always check for current pricing—ed.]. After some internal mounting hardware is removed from these boxes, the tuner easily fits inside with room to spare. Note that these boxes are weather resistant and not weatherproof. Weatherproof would be better, but with some silicone caulk at key locations, they are good enough and the price is certainly right. If you have access to other types of weatherproof boxes, use them. I prefer to avoid the clear plastic food containers as they usually get destroyed by U/V radiation rather quickly. The Fiberglas boxes or those specifically designed for outdoor use should last for years.

For the antenna connection post, I used another brass bolt fed through the box housing and bolted securely to the box. An extra set of washers both inside and outside is used to wrap the bare wire of the antenna (outside) and connect to the tuner (inside). The entire box was mounted to a steel fencepost that is easily pounded into the ground. A wooden fencepost would be just as useful. As mentioned above, parts are available from: Fair Radio Sales, P.O. Box 1105, Lima OH 45802; telephone (419) 223-2196 or (419) 227-6573.

Conclusion

So there you have it: a complete remote antenna tuning system at a penny-pinching price. I hope you have

Parts List

Tuner

Tuner/w roller inductor	*AL-AM3349-96
or	*AL-GRC-106
Tuner w/o roller inductor	
Fiberglas™ case	*FIB-SR-684
RF relays (K1, K2)	*50F212DC
C27a - 300 pF cap (for 160 m)	*various high-voltage types at least 50 μH (see text)
Loading inductor	
DB25 Female	**276-1548

Remote

Project circuit board	**276-168
LED bar graph	**276-081
20-position DIP socket	**276-1991
Fuse, 1 Amp fast-acting	**270-1273
Fuse holder	**270-1281
R1-R10, 1 kΩ, 1/4 W	**271-1321
S6-S9 SPST switch	**275-634
S4, S5 DPDT switch, center off	**275-664
Power connectors for box	**your preference
Enclosure box	**270-223 or equivalent

To connect remote box to tuner:

Rotor cable	**278-874 or equivalent
-------------	-------------------------

* Fair Radio Sales part #

** Radio Shack part #

Table 4. Parts list with author's recommended part numbers.

realized from reading this article that my antenna system is not meant to be duplicated exactly; build what is right for you and your setup. I have tried to present alternatives that would help steer you in the right direction for your specific antenna setup. Use your own imagination to make what is best for you. After all, isn't that what got you into ham radio in the first place?

From Micro Computer Concepts

RC-1000 REPEATER CONTROLLER

- Autopatch • Reverse Autopatch
- User Programmable CW ID, Control & User Codes & Timeouts

Manual with schematics • 90-Day Warranty
Wired & Tested w/ manual **\$199.95**

 Micro Computer Concepts
8849 Gum Tree Ave.
New Port Richey, FL 34653

 **813-376-6575**

CIRCLE 160 ON READER SERVICE CARD

See the FUN you've been missing!



Slow Scan TV

Every day more and more hams are enhancing their enjoyment of ham radio by adding images to their conversations. Join the fun!

new Pasokon TV Lite \$30 + \$3 shipping.
Pasokon TV Classic \$200 + \$5 shipping.

Absolute Value Systems
115 Stedman St. #7
Chelmsford, MA 01824-1823
(508) 250 0611

<http://www.ultranet.com/~sstv>

CIRCLE 351 ON READER SERVICE CARD

WEB & Internet Access
Compliments of EriNet

DAYTON hamvention®

May 15, 16, 17, 1998 ■ Hara Arena, Dayton Ohio

SPONSORED BY THE DAYTON AMATEUR RADIO ASSOCIATION, INC.

TICKET DEADLINES

- Advanced registration orders must be postmarked no later than May 1 (USA) or April 24 (Canada).
- Ticket requests that are received **AFTER** the deadline will be processed and **HELD** for pick-up at the Hara Arena box office beginning Wednesday, May 13 at 9:00 a.m.

EXHIBIT SPACE

See our Web site for more information. (www.hamvention.org)

■ Inside Exhibit Booths

For an application, please Fax (937) 376-4648 or E-mail to exhibits@hamvention.org

■ Outdoor Flea Market Space

For an application, please Fax (937) 276-8902 or E-mail to fleamkt@hamvention.org
Flea market spaces are sold IN ADVANCE ONLY. No spaces sold at gate!

UNOFFICIAL ACTIVITIES

To be listed in our program and on our Web site, please Fax (937) 274-8369 or E-mail to info@hamvention.org

SPECIAL SERVICES

Details are available on our Web site. (www.hamvention.org)

- A limited number of paid reserved ADA parking permits are available. Free ADA off-site parking is also available. Please send requests via Fax/Phone: (937) 669-1163 or E-mail to lmccoy@glasscity.net
- License Exams reservations are recommended. Walk-ins accepted, if room is available.

BUS SERVICE

Bus service will be provided between Hamvention, Air Force Museum, Salem Mall and Forest Park Mall parking areas. Check our Web site for more information. (www.hamvention.org)

COMMUNICATIONS

WWW: <http://www.hamvention.org>

MAIL: Hamvention, Box 964, Dayton, Ohio 45401-0964

FAX : (937) 274-8369

E-Mail: info@hamvention.org

PHONE: (937) 276-6930. Chairman Voice Mail box numbers are available on our Web site.



General Chairman: Dick Miller, N8CBU

Asst. General Chairman: Jim Graver, KB8PSO

ADVANCE REGISTRATION

FOR CHECK OR CREDIT CARD ORDERS:

Make checks payable to: Dayton HAMVENTION
Enclose the amount indicated in U.S. dollars. For credit card orders, please add \$1.25/ticket service charge. A \$25 service charge will be assessed on all returned checks.

Mail to: Dayton Hamvention Box 1446 • Dayton, OH • 45401-1446
or FAX to (937) 278-4633

Please type or print your name and address clearly!

	Quantity		
Admission	_____	@ \$15.00*	= \$ _____
(valid all 3 days)			
Grand Banquet	_____	@ \$30.00**	= \$ _____
Alternate Activities			
Saturday Luncheon	_____	@ \$10.00	= \$ _____
Credit Card Service Charge.	_____	@ \$1.25/ticket	= \$ _____
			Total \$ _____

* \$20.00 at door **\$35.00 at door, if available



Call _____ Expiration Date: _____
Month Year

Name _____
Address _____
City _____ State _____ Zip _____
Daytime Phone () _____ Evening Phone () _____

PLEASE PRINT! THIS IS YOUR RETURN LABEL.



Techno-Trouble for Know-It-Alls

How many of these 50 questions can you answer correctly?

Steven D. Katz WB2WIK/6
21101 Celtic St.
Chatsworth CA 91311

Newcomers and old-timers alike hold misconceptions regarding our hobby. Both technically and operationally, only a handful out of every 100 licensed amateurs really understand what it's all about—sad, but undeniable. The source of my “statistics” is my own experience in meeting with fellow hams at radio club meetings, swap meets and hamfests, and, of course, on the air.

As we have “dumbed down” the hobby—and it is absolutely dumbed down compared to 30 or 40 years ago—hams have become appliance operators who memorize question pools to pass their exams. Many have come from the CB ranks, where they were exposed to much misinformation represented as technical fact. Even many old-timers create their own realities based on unfortunate experiences that are not the norm. I'll offer some examples in this article.

Take a few moments to answer these easy questions, and see if *you* arrive at the correct conclusions. Each is a “true or false” question with only one right answer.

1. A great indicator of an antenna's performance or efficiency is having a low SWR. **T/F**

2. If your SWR meter or bridge, or directional wattmeter located near your transmitter, indicates a low SWR, both your antenna and transmission line are probably good. **T/F**

3. If you increase the height of your 40-meter dipole from 20 feet to 40 feet above ground, your station performance will increase by approximately 3 dB. **T/F**

4. If you increase the height of your two-meter vertical antenna from 20 feet to 40 feet above ground, your station performance will increase by approximately 3 dB. **T/F**

5. If you want to add a two-meter “brick” power amplifier to your station, and locate it near your rig (in the shack), you definitely want to use one with a built-in low noise preamplifier, to help pull in the weak signals. **T/F**

6. Your 12 VDC-powered, 100 W output transceiver or amplifier should be connected to its power supply by #12 gauge wiring, as long as the wiring is not longer than 12 feet. **T/F**

7. It is safe and permissible to run a 1,000 W output amplifier powered by a 115 VAC power line in your home. **T/F**

8. An ideal two-meter “base station” antenna system for FM use would be a pair of stacked 13-element yagis. **T/F**

9. A pair of two-meter vertical antennas, installed at least one wavelength apart horizontally, with a shack-mounted phase shift network to adjust the phasing between the antennas, would be a better choice than the pair of 13-element yagis discussed in question #8 above, for most amateur work. **T/F**

10. It is important to cut your coaxial cable to exact increments of one-half wavelength at your operation frequency in order to achieve optimum performance from your antenna system. **T/F**

11. It's a good idea to install a 1,000-ohm carbon composition resistor across the feedpoints of your base station antennas that are not of “DC-grounded” design. **T/F**

12. The loss in coaxial cable is proportional to its length, but inversely proportional to its velocity factor and the diameters of its inner and outer conductors. **T/F**

13. “Open wire” transmission line, or “ladderline,” is a great choice for very low-loss or high-power operation at 146 MHz. **T/F**

14. To directly bury coaxial cable, be sure to use cable rated for “direct burial.” **T/F**

15. The path loss for Earth-moon-Earth propagation on two meters is about 260 dB. T/F

16. The path loss for Earth-moon-Earth propagation on 40 meters is somewhat lower than it is on two meters. T/F

17. TVI problems resulting from six-meter transmission can usually be cured with an effective high-pass filter installed at the television set. T/F

18. You should always use a low-pass filter on your HF (3-30 MHz) transmitter or transceiver, to reduce harmonic radiation on 80, 40, and 20 meters. T/F

19. Use a balun installed at the center of your HF dipole to help provide the lowest possible SWR. T/F

20. If you use an antenna tuner or transmatch in the shack, to help tune your coaxial cable-fed antenna, this will reduce transmission line loss and stresses on the cable itself. T/F

21. When you are operating in a different US call area other than the one indicated by your license callsign, it is unnecessary to sign "portable." T/F

22. The modes of transmission, listed by order of efficiency from best to worst, are CW, RTTY/AMTOR, SSB, FM and DSB AM. T/F

23. The voltage across the feedpoints of a 50-ohm antenna system operated at resonance, when running legal-limit (1500 W PEP output) power, cannot be higher than 274 volts peak. T/F

24. UHF (PL-259) coaxial connectors all have loss when used at 146 MHz. T/F

25. When installing connectors on coaxial cable, be sure to weather-seal both ends of the cable extremely well. T/F

26. A good way to support coaxial cable when routing it to your antenna is to tightly tape it to the antenna mast, tower, or other supporting structure using high-grade electrician's tape. T/F

27. Copperclad (copper-coated steel) wire makes the best wire antennas. T/F

28. Given a choice, a mountaintop is always the best operating location. T/F

29. The highest Field Day score ever made was by a multi-operator station running kilowatts on all bands. T/F

30. Meteor scatter is a great way to work long distances on 1.2 GHz. T/F

31. Good advice for setting up a new station would be to spend most of your budget on a great transceiver, then use what is left over for your antenna and transmission line, then station accessories. T/F

32. Headphones are an annoyance which will not let you hear weak signals any better than will a good speaker. T/F

33. If you want to work DX, the best time to do it is when everybody else is working it. T/F

34. There is considerable danger associated with operating high power and using a low antenna close to your operating position. T/F

35. Using double-shielded coaxial cable will normally help reduce TVI. T/F

36. It is best to install a solid station ground, using an eight-foot ground rod as a minimum, to optimize station performance and reduce interference. T/F

37. Clamp your antenna tower securely to the side of your house to make it stronger and reduce the need for other guying. T/F

WE SHIP WORLDWIDE

Barry Electronics Corp.

WORLD WIDE AMATEUR RADIO SINCE 1950
Your one source for all Radio Equipment!

KITTY SAYS: WE ARE OPEN 7 DAYS A WEEK
*Sat. 10-5 *Sun. 12:30-6 *M-F 9-6 *Come to Barry's for the best buys in town.*



WHEREVER I GO, I TAKE MY RADIO.
SPECIALIST IN RADIOS:
•BUSINESS •MARINE
•AVIATION •HAM RADIOS
•SCANNERS

KENWOOD

SHORTWAVE RECEIVERS
R-10, R-100, R-7000, R-8500
R-9000, PCR-1000

NEW — 220 MHz
BUSINESS RADIOS
WITH REPEATERS

MOTOROLA
RADIOS
EXPORT &
DOMESTIC
CALL FOR
PRICES

TH-79A(D) Kenwood FT-51R Yaesu

Business Radios:
Motorola, ICOM, Maxon, Yaesu,
FTH 2008/7008, etc. Uniden,
Regency, Relem
Marine ICOM: M10A, mil, etc.
Aviation ICOM: A22, A200

Electron Tubes
3-500z, 572B, 6JS6C,
12BY7A, & 6146B

FT-50R Yaesu

Save money on batteries.
Call for Special Prices.

Barry's supplies all
MFJ products
Call us direct.

Wide selection of SW &
Amateur Publications

COMMERCIAL
& HAM
REPEATERS
STOCKED.
WRITE FOR
QUOTES

KANTRONICS
KAM PLUS Etc.

New satellite Telephone
"Hand-Heid"
for world-wide use!
Go from country to country and make
and receive phone calls \$3,100.

GARMIN &
MAGELLAN
GLOBAL POSITIONING
SYSTEMS

**Fm & AM Broadcast
Transmitters Stocked**

NEXTEL Radios-5 through
coverage in NY.

Surveillance Devices Available

Shortwave Receivers
Drake • Grundig • JRC • Sony
Sangean • Panasonic • Yaesu
ICOM • Lowe • Kenwood

Computer Interfaces
Stocked: MFJ-1270B,
MFJ-1274, MFJ-1224, Kam
Plus, KPC-3, MFJ 1278T,
PK-900, DRSI PRODUCTS
DSP 2232

Antenna Tuners:
MFJ,
ICOM, KENWOOD,
YAESU, VERTEX

MOTOROLA AUTHORIZED DEALER
KACHINA COMMUNICATIONS DEALER
AUTHORIZED
DEALER
SONY
Shortwave Radios Stocked

**Bird Wattmeters &
Elements in Stock**

**BENCHER PADDLES,
BALUNS, LOW PASS FILTERS
IN STOCK**

ASTRON POWER SUPPLIES
Belden Wire & Cable, Int'l Wire

BARRY ELECTRONICS CORP., 540 BROADWAY, NY, NY 10012 (Five blocks N. of Canal St., between Spring & Prince St.) **FAX 212-925-7001 Phone 212-925-7000**

New York City's LARGEST STOCKING TWO WAY RADIO DEALER
COMPLETE REPAIR LAB ON PREMISES

"Aqui Se Habla Espanol"
BARRY INTERNATIONAL
FAX 212-925-7001 Phone 212-925-7000
For Orders Call 1-800-990-2929

Monday-Friday 9 AM to 6 PM
Saturday 10-6 PM / Sunday 12:30-6

Subways: #6 Spring St. stop, N. or R. train to Prince St. stop.
F train to Houston St. stop.
Bus: Broadway bus to Prince St. stop, Path train to 9th St./6th Ave.

SALES FINAL

Technical help offered upon purchase

FAX: 212-925-7001

e-mail: barry_electronics@compuserve.com

We stock: Alinco, Ameco, Ameritron, Antenna Specialist, ARRL, Astatic, Astron, Belden, Bencher, Bird, Butternut, CES, Cushcraft, Codan, Daiwa, Eimac, Henry Heil, Hustler, Hy-Gain, Icom, KLM, Nextel, Kantronics, Kenwood, Larsen, Maxon, MFJ, Mirage, Motorola, Nye, Palomar, RF Products, Shure, Standard, TUBES & Tube Cartons, Uniden, Yaesu, Vibroplex, Duplexers, Repeaters, Scanners, Radio

WE NOW STOCK COMMERCIAL COMMUNICATIONS SYSTEMS
DEALER INQUIRIES INVITED PHONE IN ORDER & BE REIMBURSED
COMMERCIAL RADIOS STOCKED & SERVICE ON PREMISES.
EXPORT orders shipped immediately. **CALL**

CIRCLE 41 ON READER SERVICE CARD

73 Amateur Radio Today • April 1998 29



Handheld Repeater Controller

Spectrum Electronic Products 10 include voice IDer, DTMF introduces the world's first Control and programming, handheld repeater controller. hang and time-out timers, No larger than most hand-held radios, the HRC-10 converts a single or dual-band radio into a full featured simplex or duplex repeater system. Key features of the HRC-10 include Digital Voice Operated Squelch (DVOS™), telemetry tones, and private voice mail slot. **\$299**
<http://www.spectrum-usa.com>
 800-566-2788 - fax 408-336-9461

CIRCLE 69 ON READER SERVICE CARD

Pay TV and Satellite Descrambling 1998

Pay TV and Satellite Descrambling 1998 includes all satellite fixes \$15.95. Satellite Hacker Package \$39.95. Hacking Digital Satellite Systems Video \$39.95. One year Subscription to Scrambling News includes web \$29.95. Best Deal. Everything here only \$99.95. C.O.D. is OK. \$6.00. Free catalog.

Scrambling News

1060 Niagara Falls Blvd., #110

Tonawanda, NY 14150

716-283-6910. www.scramblingnews.com

CIRCLE 36 ON READER SERVICE CARD

PC HF Facsimile 8.0

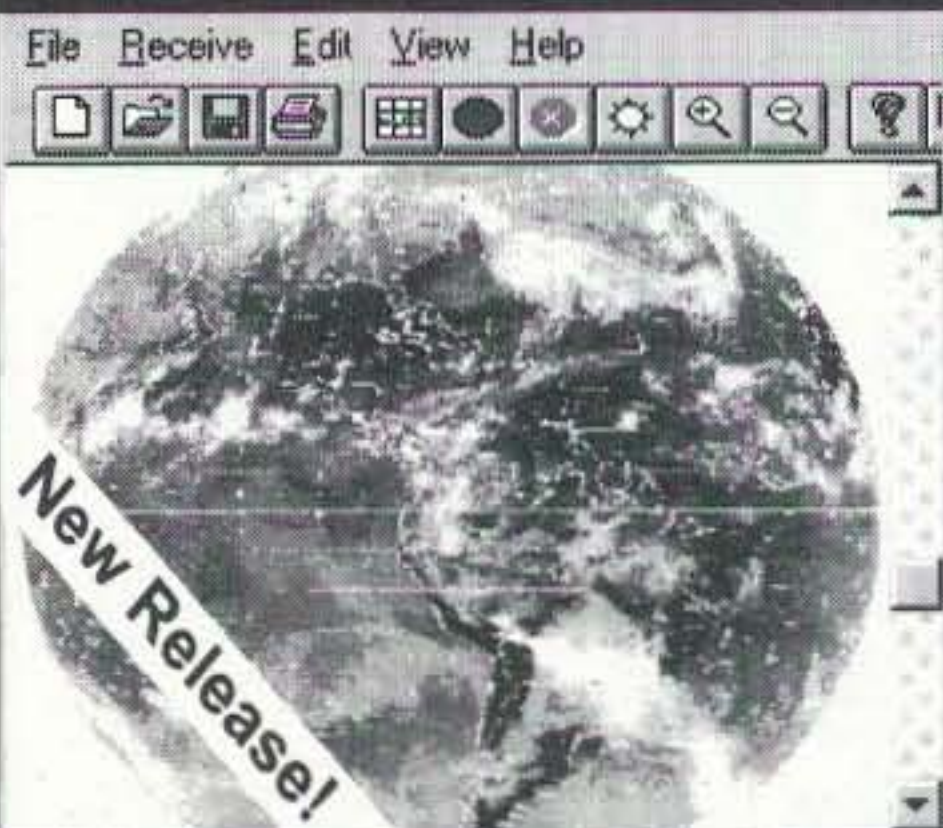

For Windows™ \$179.95

SSC is proud to announce PC HF Fax 8.0 for Windows. Now you can receive weather Fax, FEC, RTTY, Morse Code, Navtex, Amtor and Sitor while working with other software. The package comes with our new Windows FSK demodulator, software, manual and database. Just plug it in, connect your receiver, and you are copying the world! Call or write for our FREE Products Catalog.

Visa and MasterCard Welcome

Software Systems Consulting



615 S. Elcamino Real
 San Clemente, CA 92672
 Tel: 714/498-5784
 Fax: 714/498-0568
<http://www.sscorp.com>

CIRCLE 250 ON READER SERVICE CARD

38. PVC is a good material for antenna masts and booms when non-conductive mounting is desirable. **T/F**

39. The best conductor in the world is gold. **T/F**

40. 50 ohms was settled on for standard coaxial transmission line impedance because it results in the lowest possible loss, and because this is the natural impedance of a half-wave dipole in free space. **T/F**

41. FM repeaters were originally established and allowed for amateur work in order to enhance the range of base-station operators. **T/F**

42. Multipath distortion on VHF-FM can usually be solved on a case-by-case basis by simply moving your antenna slightly. **T/F**

43. The lower the operating frequency, the longer the wavelength, and the better the long-range propagation. **T/F**

44. Radio waves travel in space at a speed of about 300,000,000 meters per second; at this rate, it takes less than three seconds for a signal to propagate from Earth to the moon, and back! **T/F**

45. An important factor in antenna or transmission line performance is to use materials with the lowest possible DC resistance; for this reason, solid conductors work best. **T/F**

46. Aluminum antennas usually require frequent maintenance because contact surfaces oxidize and increase resistance. **T/F**

47. It is best to replace your outdoor coaxial cable every 20 years, even if it still looks good. **T/F**

48. The problem with tube-type transmitting amplifiers is that they require tuning, and the high voltages used create the need for low-loss wiring. **T/F**

49. A quarter-wave whip, single-band mobile antenna normally has a transmit power rating of 200 watts. **T/F**

50. If you use 100 feet of coaxial cable to feed your station antenna, you are going to lose at least 30 watts of transmit power in the cable. **T/F**

Easy ones, huh? Check your results. The real answers appear below:

1. *False.* A low SWR results from matching the antenna impedance to the transmission line impedance and

indicates absolutely nothing else. A good dummy load will have a perfect SWR and won't get out worth a darn.

2. *False.* Beware of false idols. A really great SWR can often mean excessive transmission line loss. Since transmission lines increase in loss without significantly changing impedance, the more lossy the line, the better the SWR will read. A 10,000-foot length of good 50-ohm coax, connected to absolutely nothing on the other end, will normally read a "perfect" SWR.

3. *False.* Impossible to accurately predict without knowing several variables, but in general the improvement in signal strength at most useful radiation angles, especially lower angles desirable for DX work, will be *much* more than 3 dB. A 20 dB improvement is not unusual. Still, there is no magic dB-per-foot formula.

4. *False.* Also impossible to accurately predict without knowing several variables, but in general the improvement, measured at distances beyond the original horizon, where signals get weak, will be *much* more than 3 dB. Again, there is no dB-per-foot formula.

5. *False.* Unless you have a very short, near-zero-loss transmission line, the preamp won't help. It will make your S-meter read higher, but will normally multiply noise and signals equally, resulting in absolutely no improvement in actual readability. Weak signals lost in your transmission line (between the antenna and preamplifier) are lost forever and cannot be recovered with a preamp. Unless your receiver is nearly dead to begin with, a shack-mounted preamp, used at the base of a normal home station transmission line (e.g., 100 feet of coaxial cable) is not likely to help—indeed, is much more likely to hinder—weak signal reception under crowded band conditions. The true test of a preamp is: Look for a very weak, barely readable signal that doesn't even move your S-meter. Close your eyes and listen to it very carefully. Then, turn on the preamp. Listen again with your eyes closed. Sound any different?

6. *False.* 12 feet of #12 gauge copper wire will drop about one-half volt at 15 amperes and create less than ideal

operating potential for your equipment. Go for at least #10, or preferably #8 gauge. You will notice most standard factory-supplied DC cables for 100 W or higher-powered radios is much heavier than #12 gauge. There's a reason.

7. *False.* Assuming a 65% efficient amplifier, to run 1,000 W out, you'll need to provide 1538 VA (volt-amperes, the AC equivalent of a watt) to your amplifier. At 115 VAC, this is 13.4 amps—way too close to the household wiring maximum rating of 15 amps, especially for sustained operations or when the amplifier shares the line with other equipment. Rewire for 230 VAC, and the current required will drop in half. Your amplifier, its power supply, and your household wiring will thank you for it.

8. *False.* This might make a great point-to-point system for a fixed and known path, but for general operating it will be a nuisance and make it difficult to contact stations in more than one direction at a time. After following a few dozen weak mobiles around, your rotator will age years in just days, and probably so will your patience.

9. *True.* And cheaper, and easier to install. And by using a two-pole multiposition transfer switch or relay system, in conjunction with various lengths of short patch cables, you'll be able to instantly "rotate" your antenna without anything physically moving. Fast, efficient, and inexpensive. And a more user-friendly system than rotating long beams.

10. *False.* Where in heck did this silly rumor start?

11. *True.* The presence of this resistor will help you pinpoint future problems, should any occur, and will not affect the performance of a 50-ohm antenna system in the slightest. Any time you wish to check your antenna or feedline connections, just disconnect the coax from your radio and use an ohmmeter to measure across the connector. It should measure 1,000 ohms. If it measures less, something is starting to short out. If it measures more, something in the system is becoming resistive. Either way, it should be investigated and fixed.

12. *True.*

13. *False.* Open wire or ladderline is high-impedance (450–600 ohm) transmission line with wide conductor spacing that is a bit *too* wide for most general VHF applications. Its radiation loss can cancel out its benefits. Also, it is difficult to convert from this high impedance back down to what most of our antennas and radio equipment were designed for; the transformation networks (baluns, etc.) will have loss at VHF that can also cancel out the other benefits of open wire line.

14. *False.* Any coaxial cable can be buried if you are careful not to nick or cut the outer insulation. Some cable types are rated "direct burial" because they have "flooded" construction, which is more suitable for this application. However, pulling any old coax through inexpensive half-inch PVC pipe (the kind used for lawn sprinkler systems) will turn just about anything into "direct burial" cheaply and easily.

15. *True.*

16. *False.* A 7-MHz signal transmitted from Earth won't reach the moon—it will reflect off the ionosphere and bounce back to Earth.

17. *False.* Six meters (50 MHz) is so close to television Channel 2 that high-pass filters rarely do much good. Might be worth a try, but don't count on miracles.

18. *False.* A low-pass HF filter has a cutoff frequency of 30–33 MHz. This allows the first nine harmonics of 80 meters to blast right through it! Also allows the first four harmonics of 40 meters, and at least the second harmonic of 20 meters, to blast through unattenuated. A low-pass HF filter is of most good on the bands above 21 MHz. Most modern-day equipment, if not tinkered with, is pure enough to not require additional help from out-board low-pass filters.

19. *False.* Another silly rumor.

20. *False.* Won't do a thing to reduce line loss or stress on the coax.

Amplifiers, ATV Down Converters & Hard to Find Parts

LINEAR AMPLIFIERS

HF Amplifiers
PC board and complete parts list for HF amplifiers described in the Motorola Application Notes and Engineering

Bulletins:

AN779H (20W)	2 Meter Amplifiers (144-148 MHz) (Kit or Wired and Tested)
AN779L (20W)	
AN 762 (140W)	35W - Model 335A, \$79.95/\$109.95 75W - Model 875A, \$119.95/\$159.95
EB63 (140W)	
AR305 (300W)	440-450 MHz Amplifiers (SSB-FM-ATV)
AN 758 (300W)	
AR313 (300W)	100W - Model KEB 67, \$159.95
EB27A (300W)	
EB104 (600W)	
AR347 (1000W)	



ATV Down Converters

(Kit or Wired and Tested)
Model ATV-3 (420-450)
(Ga AS - FET)
\$49.95/\$69.95
Model ATV-4 (902-926)
(GaAS - FET)
\$59.95/\$79.95

HARD TO FIND PARTS

- RF Power Transistors
- Broadband HF Transformers
- Chip Caps - Kemet/ATC
- Metallized Mica Caps - Unelco/Semco
- ARCO/SPRAGUE Trimmer Capacitors

We can get you virtually any RF transistor!
Call us for "strange" hard to find parts!

DIGITAL FREQUENCY READOUT
For older analog transceivers
TK-1 (Wired and Tested)\$149.95

For detailed information and prices, call or write for our free catalog!

ADDITIONAL ITEMS

Heat Sink Material
Model 99 Heat Sink (6.5" x 12" x 1.6"), \$24.00
CHS-8 Copper Spreader (8" x 6" x 3/8"), \$24.00
Low Pass Filters (up to 300W) for harmonics
Specify 10M, 15M, 20M, 40M, 80M or 160M
HF Splitters and Combiners up to 2KW

Add \$4.50 for shipping and handling

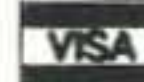

CCI Communication Concepts Inc.

508 Millstone Drive • Beavercreek, Ohio 45434-5840
Phone: (937)426-8600 • Fax (937)429-3811
E Mail: cci.dayton@pobox.com

CIRCLE 99 ON READER SERVICE CARD

The NiCad Lady - N6WPA

Losing your source of power?

Have your old case refitted with NEW cells and \$ave!

Convert your pack to NiMH!

Same size pack — HIGHER capacity!

*Handhelds *LapTops *Commercial Radios *Camcorders

*Portable Scanners *Test Equipment *Power Tools

*Any Special Application

NEW replacement packs & Individual cells also available!

Call for a price list!

17052 Alameda Drive Perris, CA 92570

(909) 789-0830

FAX (909) 789-4895

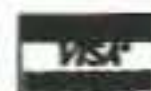

CIRCLE 141 ON READER SERVICE CARD

21. *True.*

22. *True.* Efficiency is inversely proportional to bandwidth. Bandwidth is directly proportional to data I/O rate (baud). CW, being slowest, is still most efficient.

23. *True.* Doesn't sound like much, does it?

24. *False.* While *everything* has some loss, including a cubic foot of solid silver, the loss in a properly installed PL-259 at 146 MHz is so low you can't measure it with conventional instruments. In fact, a line splice properly made using two PL-259s and a PL-258 double-female adapter (barrel) measures less than 1/10 of 1 dB loss at 146 MHz. This is an imperceptible change.

25. *False.* Weather-seal the antenna fitting, for sure! It doesn't pay to weather-seal the shack end (indoor) fitting. Let it breathe a bit, so changes in barometric pressure (which occur daily) will allow the same changes inside the cable. This helps avoid condensation building up inside the cable.

26. *False.* Coaxial cable, other than hardline types, is soft and should not be overly compressed. Several layers of tape, pulled taut during installation, can be detrimental to the health and life of your cable. Tape is OK, when installed in sweeping, loosely overlapped layers occupying several inches of cable at a time. Don't pull it too tightly.

27. *False.* Steel is strong, but that's its only benefit. The copper usually flakes off the steel in an alarmingly short time, leaving rusty steel exposed. When this occurs at connection points, even if they are soldered, it can increase resistance and degrade antenna performance. Stick with pure copper for best long-term results.

28. *False.* Depends on the frequency, propagation and location specifics. The "lowfers" (low-frequency operators, using 1.8 and 3.5 MHz, for example) usually find a beachfront to be a better location than any mountaintop—and even some VHF propagation favors lower elevations. There are too many variables to make a general rule on this one.

29. *False.* Highest score was set by the Conejo Valley ARC (in California) a few years back, using 5 W maximum

output power on each band. It's a record that hasn't been broken yet by anybody. (By the way, I was there and was FD Chairman of the club that year. On most bands, we actually ran about 3 W output, and all stations were either battery- or solar-powered.)

30. *False.* If a meteor scatter contact has ever been made on 1.2 GHz, it hasn't been documented.

31. *False.* Invest in a great antenna system and transmission line, then receiver and headphones and maybe a noise reduction system, then comes the lowly transmitter. You'll be glad you spent your hard-earned bucks in this order. Regardless of what is spent where, the most important component of any competitive amateur station is the operator!

32. *False.* Good 'phones make a world of difference. Haven't you ever noticed you can hear more music with a Walkman™ than with a \$5,000 home stereo system having huge speakers? The closer the signal source is to your eardrum, the better you'll hear it. Even inexpensive headphones reproduce high and low frequencies better, with less distortion, than loudspeakers costing many times more.

33. *False,* usually. If you're a well-trained and experienced operator with a great, competitive station, then I'd change this to a "true." But for most of us, working DX is easier when locals aren't on the air clogging up the bands.

34. *True.* Biohazards and effects are still not completely understood, but there is lots of documented evidence that they exist and that proximity makes it much worse. If you want to run a kilowatt, please use an antenna that is far away from your operating position! (A good rule of thumb might be: If you can see your antenna, it's probably too close.)

35. *False.* Possible, but unlikely. Most interference including TVI is radiated by your antenna system, which is *supposed* to radiate! Your coax won't radiate very much, whether it's single- or double-shielded. Raising your antenna substantially above the elevation of your neighbors' homes reduces interference better than any other single trick.

36. *False.* Can anyone prove this? I highly doubt it. An effective RF station ground is very difficult to accomplish for most of us. A DC station ground, or "utility" ground, is strongly recommended to prevent the possibility of shock hazard should a short-circuit arise in your equipment, but this has nothing to do with installing ground rods.

37. *False.* It's easy, and if the house is already there and built very strongly, it might be a good idea in some cases. However, your house wall was not designed to hold up a tower. In some cases, it will be disastrous, as in the case of an earthquake that shakes up everything and causes the tower to pull a hole in the wall of your home (I've seen it happen, as recently as January 1994).

38. *False.* Some PVC might be a good RF insulator, but a lot of it is not. You can perform a simple test by trying some out in your microwave oven and putting it on "high" for a minute. If the PVC gets hot, it is NOT a good insulator!

39. *False.* It's silver. And then copper. Gold ranks a lowly third, just above aluminum.

40. *False.* Ideally, coax would be 70 ohms, for minimum loss per unit length. That's why cable TV companies standardized on this higher impedance. However, as a compromise between attenuation, which is lowest at 70 ohms, and power handling (related to current), which is highest at 30 ohms, 50 ohms was settled on back in the late 1940s and has been the two-way radio standard ever since.

41. *False.* They were designed and intended to enhance the range of mobile stations.

42. *True.* Try it.

43. *False.* You're kidding, right? If propagation were inversely proportional to frequency used, we'd all be on 160 meters all the time, wouldn't we?

44. *True.*

45. *False.* RF conducts only on the outermost surface of a conductor ("skin effect") and it doesn't matter whether a conductor is solid or hollow. The larger the surface area (skin area)

of the conductor, the lower its RF resistance will be. The RF skin depth in the amateur spectra is minuscule, with all the current conducted by the outer 1,000th of an inch or so.

46. True.

47. False. Coax used outdoors should be inspected and tested every year or two, and probably replaced every five or six years. Some "hardline" (solid outer conductor) types will last much longer, and so will conventional, flexible cables used exclusively indoors.

48. False. Tuning isn't a problem—it is often a benefit when it comes to reducing spurious emissions. And low-loss wiring isn't required at high voltages: High-voltage wiring (with a healthy insulation) is!

49. False. Most quarter-wave whips will handle a kilowatt with ease.

50. False. Loss cannot be expressed in watts. It varies with length, frequency, cable constants, altitude, and other variables, but it cannot be expressed in watts no matter how you look at it. It can be expressed as a percentage, or, more commonly, in dB per unit length, e.g., 3 dB per 100 feet at 222 MHz.

So, how'd you really do, kiddo?

Although these are relatively easy questions, I have found that 99% of all newcomers, and about 70% of all old-timers, get at least three answers wrong. Tsk, tsk, tsk.

I'll come up with another 50 questions next time and we'll see how you do then!

Radio Bookshop

Phone 800-274-7373 or 603-924-0058, FAX 603-924-8613, or see order form on page 88 for ordering information.

Code Tapes

73T05 **Genesis 5 wpm code tape** This beginning tape takes you through the 26 letters, 10 numbers and necessary punctuation complete with practice every step of the way. \$7.00

73T06 **The Stickler 6 wpm code tape** This is the practice tape for those who survived the 5 wpm tape and it is also the tape for the Novice and Technician licenses. It is comprised of one solid hour of code. Characters are sent at 13 wpm and spaced at 5 wpm \$7.00

73T13 **Back Breaker 13 wpm code tape** Code groups again at a brisk 13+ wpm so you'll be really at ease when you sit down in front of a steely-eyed volunteer examiner who starts sending you plain language code at only 13 per. \$7.00

73T20 **Courageous 20+ wpm code tape** Go for the Extra class license. \$5.95

73T25 **Mind Boggler 25+ wpm code tape.** \$7.00

- DIP switch programmable
- CTCSS encoder
- All 32 EIA tones from 67.0 to 203.5 hz included
- May be ordered with custom tones

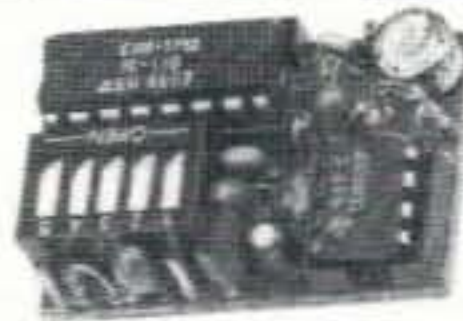

SS-32PA Encoder
.9" x 1.3" x .4"

SS-32PA DIP Switch Programmable CTCSS Encoder \$28.95

- Fully enclosed CTCSS encoder
- All 32 EIA tones from 67.0 to 203.5 hz included
- Perfect for mobile / base applications



TE-32
5.25" x 3.3" x 1.7"

TE-32 Multi-Tone CTCSS Encoder \$49.95

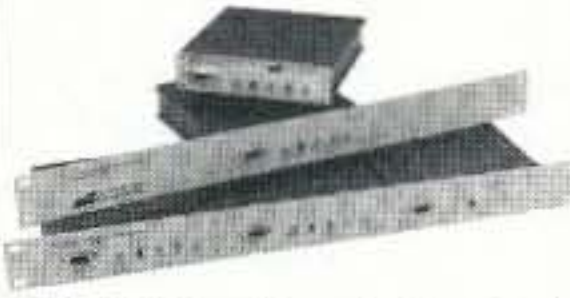

TP-3200 Shared Repeater Tone Panel

TP-3200D Table Top Version

TP-3200RM-A Single Rack Mount version

TP-3200RM-B Triple Rack Mount version

*Holds up to three TP-3200s

- 51 CTCSS Tones
- 106 DCS Codes
- Supports 157 Repeater Subscribers
- On-Line Computer Help
- Repeater CW ID
- Air Time Loading & Analysis Graphs
- Signalling Formats: CTCSS DCS & DTMF

\$269.95 each

\$279.95 each

\$279.95 each

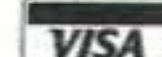

ID-8 Automatic Morse Code Identifier
1.85" x 1.12" x .35"

NEW
LOWER
PRICE

\$69.95

ID-8 Automatic Morse Station Identifier \$89.95

Call or write to receive our full Product Catalog or visit our Web site for complete information at:
<http://www.com-spec.com>



COMMUNICATIONS SPECIALISTS, INC.

426 WEST TAFT AVENUE • ORANGE, CA 92665-4296

(714) 958-3021 • FAX (714) 974-3420

Entire U.S.A. (800) 854-0547 • FAX (800) 850-0547

<http://www.com-spec.com>

CIRCLE 10 ON READER SERVICE CARD

CALL TOLL FREE
(800) 292-7711 orders only
Se Habla Español

YOUR ONE STOP SOURCE
FOR ALL YOUR TEST
EQUIPMENT NEEDS

CALL OR WRITE FOR OUR
NEW FREE 64 PAGE
CATALOG!
(800) 445-3201

NEW XK-700 Digital / Analog Trainer
Elenco's newest advanced Digital / Analog Trainer is specially designed for school projects. It is built on a single PC board for maximum reliability. It includes 8 built-in power supplies, a function generator w/ continuously sine, triangular and square waveforms, 1,560 tie point breadboard area. Tools and meter shown optional. (Mounted in a professional tool case made of reinforced metal).

XK-700
Assembled and Tested
\$189.95

XK-700-SEMI Kit
Assembled and Tested
\$174.95

XK-700K - Kit
\$159.95 Made in U.S.A.

Elenco Scopes
Free Dust Cover & Probes

S-1325 25MHz \$325
S-1330 25MHz Delayed Sweep \$439
S-1340 40MHz \$475
S-1345 40MHz Delayed Sweep \$569
S-1360 60MHz Delayed Sweep \$749
S-1390 100MHz Delayed Sweep \$895

DIGITAL SCOPE SUPER SPECIALS
DS-303 40MHz/20M/s Analog/Digital \$895
DS-603 60MHz/20M/s Analog/Digital \$995

4 Functions in One
MX-9300
\$459.95

Features

- One instrument w/ four test leads and measuring systems.
- 1.3GHz Frequency Counter
- 2MHz Sweep Function Generator
- Digital Multimeter
- Digital Triple Power Supply
- 0-30V @ 3A, 15V @ 1A, 5V @ 2A

NEW Tektronix DMMs

- 40,000 Count
- High Accuracy
- Tektronix Quality
- 3 Year Warranty

DMM 912 \$179
DMM 914 \$229
DMM 916 \$275

20MHz Sweep/Function Generator with Frequency Counter
Model 4040

- 0.2Hz to 20MHz
- AM & FM Modulation
- Burst Operation
- External Frequency Counter to 50MHz
- Linear and Log Sweep

10MHz - Model 4017 \$309
5MHz - Model 4011 \$239 **\$399**

Fluke Scopemeters

122 NEW \$950
905 \$1445
908 \$1495
968 \$1895
97 \$1695
995 \$2095
1058 NEW \$2495

ALL FLUKE PRODUCTS ON SALE!!

Technician Tool Kit
TK-1500

28 tools plus a DMM contained in a large flexible tool case with a handle ideal for everyone on the go! **\$49.95**

Fluke Multimeters

Model 26II	\$63	Model 12	\$84
Model 70II	\$85	Model 83	\$235
Model 73II	\$115	Model 85	\$269
Model 75II	\$139	Model 87	\$289
Model 77II	\$154	Model 863E	\$475
Model 79II	\$175	Model 867BE	\$650

B&K Precision Multimeters

Model 389	\$109	Model 388A	\$99
Model 390	\$127	Model 2707	\$75
Model 391	\$143	Model 2860A	\$79
Model 5360	\$195	Model 5370	\$219
Model 5380	\$265	Model 5390	\$295

DIGITAL LCR METER
Model LCR-1810

- Capacitance 0.1pf to 20µF
- Inductance 1µH to 20H
- Resistance .01Ω to 2000MΩ
- Temperature -20°C to 75°C
- DC Volts 0-20V
- Frequency up to 15MHz
- Diode/Audible Continuity Test
- Signal Output Function
- 3 1/2 Digit Display

\$99.95

B&K High Current DC Power Supply

- Variable 3-14VDC
- Thermal Function
- Current Limiting

Model 1686 12A **\$159**
Model 1688 25A **\$239**

B&K 13.8V Fixed DC Power Supplies
Model 1680 6A \$39
Model 1682 15A \$75

Quad Power Supply
Model XP-581

Four Fully Regulated DC Power Supplies in One Unit
4 DC Voltages: 3 Fixed;
• +5V @ 3A
• +12V @ 1A
• -12V @ 1A
• 1 Variable 2.5 - 25V @ 3A

\$89.95

Digital Multimeter
Model M-1700
\$39.95

11 functions including freq. to 20MHz, cap to 20µF. Meets UL-1244 safety specs.

10% OFF ON ALL STANDARD AMATEUR RADIO PRODUCTS Including Accessories

Elenco LCR & DMM
Model LCM-1950
\$69

12 Functions
Freq to 4MHz
Inductance
Capacitance

Handheld Universal Counter
F-2800
1MHz - 2.8GHz

Features:

- 16 segment HF signal strength bargraph 1MHz - 2.8GHz.
- 16 segment RF signal strength bargraph.
- 6 hour NOD battery operation.
- High speed 250MHz direct count for high resolution.

NEW \$99

Kit Corner over 100 kits available

Model AR-2N6K
2 Meter / 6 Meter Amateur Radio Kit
\$34.95

Model AM/FM-108K
Transistor Radio Kit **\$29.95**

Repair System Soldering and Desoldering Station Model SL-916
Top-of-the-line repair system will handle desoldering. Temperature controlled soldering from 300°F to 790°F (150°C to 420°C), desoldering temperature range 410°F to 900°F (210°C to 480°C). The system is based on principle of vacuum absorption of the solder from the PC board.
SL-916 - Desoldering System with Digital Display also available. \$325.00
\$425.00

35mm Camera Kit
Model AK-540
Learn all about photography
\$14.95
No Soldering Required

Radio Control Car Kit
Model AK-870
• 7 Functions
• Radio Control Included
\$24.95
No Soldering Required

Guaranteed Lowest Prices **C&S SALES, INC.**
150 W. CARPENTER AVENUE
WHEELING, IL 60090
(847) 541-0710 • FAX: (847) 541-9904
http://www.elenco.com/cs_sales

15 DAY MONEY BACK GUARANTEE
FULL FACTORY WARRANTY
PRICES SUBJECT TO CHANGE WITHOUT NOTICE

CIRCLE 184 ON READER SERVICE CARD

SPECIAL EVENTS

Listings are free of charge as space permits. Please send us your Special Event two months in advance of the issue you want it to appear in. For example, if you want it to appear in the July issue, we should receive it by April 30. Provide a clear, concise summary of the essential details about your Special Event.

MAR 28

MICHIGAN CITY, IN The annual Michigan City Hamfest and Computer Flea Market will be held at Michigan City High School, 8466 W. Pahs Rd., Michigan City IN, 8 a.m.-2 p.m. CST. Early setup provided for vendors. Admission is \$4; children under 12 admitted free with a paid adult. Contact *Ron Stahoviak N9TPC*, 5802 N 400 W, Michigan City IN 46360. Tel. (219) 325-9089.

WEATHERFORD, TX The Amateur Radio Club of Parker County will hold its 10th annual Hamfest at the Weatherford National Guard Armory. VE exams will be given for all classes. Flea Market setup 5 p.m.-9 p.m. Fri., and 6 a.m. Sat. Exams begin at 8 a.m. Talk-in on 147.040 tone 110.9. For pre-registration and vendor info, contact *Elizabeth Hunkele N5ONE*, 1507 Old Garner Rd., Weatherford TX 76088. Tel. (817) 594-1700, or fax WA4IXN at (817) 599-6717.

APR 3-4

ATLANTA, GA The 2nd annual Southeastern VHF Society Technical Conference will be held Fri. and Sat., April 3rd and 4th, in Atlanta GA. Antenna measurements will be done on Friday, starting with 144 MHz and working up in freq., amateur bands only, please. A maximum of two antennas per band per individual may be tested. Please supply a Female N connector or SO-239. Please pre-register. For more info, contact *Antenna Measurements Chairman Dale Baldwin WB0QGH* at [wb0qgh@mindspring.com]. Noise Figure Testing will be conducted on Saturday. For more info, contact the *Noise Figure Measurement Co-Chairman Charles Osborne WD4MBK*, at [cosborne@pipeline.com]; or *Fred Runkle K4KAZ* at [engineer@rightmove.com]. There will be a Friday evening flea market, a Saturday evening banquet, SVHFS auction, and family program. You are invited to visit the Web site at [www.akorn.net/~ae6e/svhfs].

LITTLE ROCK, AR The Central Arkansas Radio Emergency Net (CAREN) will hold their All Arkansas Family Hamfest at Sherwood Forest Convention Center, 111 West Maryland Ave., Sherwood AR. Free admission. Talk-in on 146.940(-). For additional info, contact *J.C. Smith N5RXS*, (501) 568-7982.

APR 4

CLAYTON, MO The annual St. Louis County SKYWARN Severe Weather Observation Training Seminar will be held on Saturday. For locations call the *Severe Weather Info Line*, (314) 889-2857. You will get a taped message and additional information. All are welcome, including those from outside the area; no advance registration required. Free parking. SKYWARN Level 1 training is presented in the morning, and classes resume in the afternoon with the SKYWARN Level 2 program. Certification is provided for RACES and SKYWARN, all at no cost. One need not be a ham operator to attend and participate in the program. Please call for additional information.

FREDERICKSBURG, PA The Appalachian Amateur Radio Group will sponsor their 10th Annual Hamfest and Computer Show at Northern Lebanon High School in Fredericksburg. Admission \$4; kids under 12 free. Indoor tables \$14 each. Tailgating \$4. Handicapped access. Setup at 6 a.m. VE exams at 9 a.m. Morning

seminars. Reservations for tables are recommended and must be prepaid. Tables not occupied by 9 a.m. are subject to resale. No refunds. Send check for reservations to *AARG*, 105 Walnut St., Pine Grove PA 17963. Tel. (717) 345-3780. Or send to *Lanny Hoffman KD3TS*, 337 N. 19th St., Lebanon PA 17046; Tel. (717) 274-2148.

WATERFORD, CT A ham radio auction, sponsored by the Radio Amateur Society of Norwich, will be held at 10 a.m. at the Waterford Senior Center on Rt. 85. From Hartford, take Rt. 2 south to Rt. 11 to Rt. 85 south. From the shoreline, take Rt. 95 to Rt. 85 north. Talk-in on 146.730(-). Bring your gear to sell (10% commission to RASON). Free admission, free parking. Contact *Tony AA1JN* at (860) 859-0162; or see the RASON Web page at [www.ims.uconn.edu/~rason].

APR 5

DELOIT, IA The Denison Repeater Assn. will host an Amateur Radio Swap Meet at the Deloit Community Building, 7 a.m.-2 p.m. Tables and admission will be \$2. Talk-in on the K0CNM repeater at 147.090. Reservations for table space may be sent to *John Amdor KD6MXL*, 1136 Street F16, Defiance IL 51527. For more info, E-mail to *KD6MXL* at [johnmxl@netins.net]. Check the Web at [http://www.netins.net/showcase/johnmxl/deloit.html].

HAMILTON TWP., NJ The Hamcomp '98 Hamfest, sponsored by the Delaware Valley Radio Assn., will be held at Tall Cedars of Lebanon picnic grove on Sawmill Rd. in Hamilton Twp. I-95 North to I-295 S; exit 60A to I-195 E; exit 2 to Yardville; South Broad St. to end, approx. 3.7 miles; left at Yield; next right onto Sawmill Rd. Site is 1.1 miles on the right. Open to buyers at 8 a.m. Open to sellers at 6:30 a.m. Admission \$5; non-ham spouses and children admitted free. Tailgating space \$10, includes one admission. ARRL table. Free parking. Covered table space \$15, includes one table and one admission, some electricity. Advance covered space reservations available. Talk-in on 146.67(-). Contact *Hamcomp '98, DVRA*, P.O. Box 7024, West

Trenton NJ 08628. Tel. (609) 882-2240; or E-mail [www.slac.com/w2zq].

MIDDLETON, WI The Madison Area Repeater Assn., Inc., will hold its 26th annual Madison Swapfest at the John Q. Hammons Trade Center in Middleton. Take Hwy. 12 (the Beltline) west of Madison and exit westbound on Greenway Blvd. Commercial exhibitors and vendors with 6 or more flea market tables will be admitted beginning at 1 a.m.; other flea market sellers will be admitted at 6 a.m. Doors open to the general public at 8 a.m. New and used electronics gear, from computers to communications equipment, will be on sale. Lots of parts for the electronics hobbyist will also be on hand. Free parking. Hotel accommodations available at the adjoining Marriott Hotel, as well as at several nearby hotels. Talk-in on the MARA rpt., W9HSY, on 147.75/.15. Admission is \$5 per person in advance, \$6 at the door. Children under 10 admitted free. 2.5-foot x 6-foot flea market tables are \$15 in advance, plus admission. Reserve early. Reservation deadline is March 28th. For tickets, tables, or spaces, write to *MARA*, P.O. Box 8890, Madison WI 53708-8890 USA. Tel. (608) 245-8890. Visit the Swapfest Web site at [http://www.cs.wisc.edu/~jeremyc/mara/swapfest/].

RALEIGH, NC The Raleigh ARS will present its 26th Hamfest/NCS ARRL Convention and Computer Fair in the Jim Graham Bldg. at the NCS Fairgrounds, 8 a.m.-4 p.m. Wheelchair access. ARRL, MARS, APRS, ARES, NTS, QRP, and DX meetings. Admission is \$5 in advance, \$6 at the door. All activities inside. Tables and booths are available. Free parking; RVs welcome. Hospitality party Sat. night. VE exams contact is *AA4MY* at (919) 676-4697. For pre-registration and dealer inquiries, contact *Wilbur Goss WD4RDT*, 4425 Watkins Rd., Raleigh NC 27616. Tel. (919) 266-7883. Talk-in on 146.04/.64.

APR 10-11

TUPELO, MS The North Mississippi Hamfest & Computer Expo '98 will be sponsored by the Tupelo ARC, Booneville ARC, and Union County

ARC, at Trace Convention Center, intersection of Highway 6 and the Natchez Trace Parkway. VE exams at 9 a.m.; bring original and copy of current license and/or CSCE, and a photo ID; walk-ins accepted. Free parking, no tailgating. Talk-in on 147.38 KC5OBD, rag-chew on 145.49. Admission \$5, under 13 admitted free when accompanied by an adult. Tables \$20; for reservations write *Jack Ellis KI5QV, Rt. 4, Box 198-B, Tupelo MS 38801; or phone (601) 842-7255. Web site is at [www.tupelofest.org].*

APR 11

BENTONVILLE, AR The Benton County Radio Operators will present a hamfest 8 a.m.–1 p.m. at Bentonville National Guard Armory, SW A and SW 8th Sts. Talk-in on 145.290(-) rptr. Contact *BCRO, P.O. Box 883, Pea Ridge AR 72751.*

APR 18

BELTON, TX "HAM EXPO—the Spring 'Fest" will be sponsored by the Temple ARC. From Interstate 35, take Exit 292 to the Bell County Expo Center. Admission \$1. Handicap accessible. Huge indoor tailgate arena; spaces \$10 (only at the door). Tables available at an additional \$10 each. Tailgate setup begins at 5:30 a.m. Free electricity. Doors open at 7 a.m. Talk-in on 146.820(-) MHz, PL 123.0 Hz. Commercial vendor space with tables, \$20 ea. (Sat. setup); or \$25 ea. for Fri. night early setup (reserve by Apr. 10th). Free electricity. Contact *Temple Amateur Radio Club, P.O. Box 4511, Temple TX 76505. Deliveries to: 1802 S. 13th St., Temple TX 76504. Phone Mike LeFan WA5EQQ at (254) 773-3590; E-mail [hamexpo@vvm.com]. Expo Web page at [http://www.tarc.org].*

JOPLIN, MO The Joplin ARC Hamfest 98 will be held at The John Q. Hammons Convention Center, 3615 Range Line Rd., Joplin MO. Setup Fri. 6 p.m.–10 p.m., and Sat. at 6 a.m. VE exam registration at 10 a.m., with exams starting at 11 a.m. Contact *Andy Gabbert KAØTUD, E-mail [agabbert@hotmail.com] or Jim Johannes NØZSQ, 1930 E. 34th St., Joplin MO 64804; E-mail [jjohannes@clandjop.com].*

APR 19

CEDAR HILL, MO The Jefferson County ARC Spring Hamfest and Computer Show will be held at the Elks Lodge, Highway 30 and BB, 20 miles west of Interstate 270. Doors open at 7 a.m.–1 p.m. Flea market setup Sun., 5 a.m. Inside table \$10; with electric \$15 (limited). Tailgate space \$5. VE exams at 9 a.m. Talk-in on 147.075/105. For info please contact *Jim KAØWXN, at (314) 296-3473. Send paid reservations to JCARC c/o Jim Autery KAØWXN, 3596 Reuter Acres, Imperial MO 63052-1034.*

SHAKOPEE, MN Canterbury Park will be the location for "Smartsfest 98 Hobby Electronics Show." This event is being sponsored by the Southwest Metro Amateur Radio Transmitting Society, Inc. Fleamarket setup Sun. morning at 7 a.m. Tables available. Electricity available. Separate entrance for sellers. Free parking. VE exams. Advance tickets \$4 ea., \$5 at the door. For more info write or call *SMARTS Inc. P.O. Box 144, Chaska MN 55318. Call Helen at (612) 361-6782 regarding flea market or advance tickets.*

STICKNEY, IL The DuPage ARC will hold their Hamfest and Computer Show at the Hawthorne Race Course, 3500 South Cicero Ave., Stickney IL, 8 a.m.–2 p.m.

Commercial dealers can set up indoors on Sat., 3 p.m.–6 p.m. Commercial and flea market setup on Sun. after 6 a.m. Tickets \$4 in advance, \$5 at the door. Free parking. For table availability call (630) 985-9256. Advance tickets \$4 each until March 30th. Send check payable to "DARC," with a #10 business-size SASE to *Hamfest 98, 7511 Walnut Ave., Woodridge IL 60517-2818.*

APR 25

SONOMA, CA The Valley of the Moon ARC, W6AJF, will hold its annual ARRL Hamfest 8 a.m.–noon at the Sonoma Valley Veterans' Memorial Building, 126 First Street West, in Sonoma. Follow Highway 12. Admission is free; bring the entire family. Walk-in VE exams; registration starts at 9 a.m. Testing for all classes begins at 10 a.m. There will be an indoor and outdoor electronics swap meet with setup starting at 7 a.m.; spaces, \$10. A full breakfast will be served 8 a.m.–10 a.m. for \$5. Pancake-only breakfast for \$3.50. Forums will include an operating QRP station and display of home-built equip., beginners' DF hunt, and more. VOMARC will participate in the QRP-to-the-Field contest, which will run during the hamfest. Guest ops are cordially invited to sit in and take a turn operating the club station. For a map and printed directions to the hamfest, send a

business-size SASE to *VOMARC, 358 Patten St., Sonoma CA 95476. Talk-in will be on 145.35(-600) PL 88.5. For more info call Darrel WD6BOR at (707) 996-4494.*

WEST GREENWICH, RI The Fidelity ARC and Washington County ARC will hold their 2nd annual hamfest 9 a.m.–4 p.m., on Rt. 3 in West Greenwich RI. Directions: From northbound I-95; take exit 5A; turn left at Rt. 3; go approx. 2 miles. From southbound I-95 take exit 6, turn left onto Rt. 3; go approx. 4 miles. Next to the West Greenwich Fire Station. Admission \$1. 6 ft. spaces, \$6 ea.; contact *Everett Lovenbury N1VEZ, 232 Carolina Nooseneck Rd., Wyoming RI 02898-1172; tel. (401) 539-1107; E-mail [N1VEZ@juno.com], or Bill May WA1WM, 20 Montana Ave., Coventry RI 02816-5510; tel. (401) 822-0520; E-mail [WA1WM@juno.com]. Setup starts at 7 a.m. VE exams at 12 p.m. (walk-ins). All classes bring ID and any CSCEs that might apply.*

APR 26

ARTHUR, IL The Moultrie AR Klub is hosting their 36th annual hamfest 8 a.m.–1 p.m. at the Moultrie/Douglas County Fairgrounds on the south side of Arthur. Admission \$4 per person over 14 years old. There will be a forum tent with something going

WE SHIP WORLDWIDE Local & Tech 1-810-771-4711, Service 1-810-771-4712, Fax Service 1-810-771-6546

Michigan Radio

SALES SERVICE

Taxes do not include shipping. Price and availability subject to change without notice. Most orders shipped same day. COD's welcome (\$5.00 shipping)

VISA **MasterCard** **Discover** **AmEx**

OPEN MON-FRI 10-6 SAT 10-4 SUN CLOSED

23040 Schoenherr, Warren, MI 48089
1-800-TRU-HAMM (orders only)
 (800-878-4260)
 E-mail at mirad@mich.com

Now on the World Wide Web <http://michiganradio.com> E-Mail at mirad@mich.com



TH-79A(D)



TMV7A



TM-742



TS-50/60



TS-950SDX



TS-570



H-22AT



TM-261A



G-71



TS-870

YAESU



FT-8500



FT-900AT



FT-50R



FT-2500M



FT-51R



VX-1R



FT



FT-920



FT-1000



FT-1000MP



FT-5100

Convert Excess Equipment to CASH We buy good clean, used equipment Estate Sales

on every hour. Flea market tables (limited) are \$10 per table paid in advance. For table info and reservations, write to *M.A.R.K., P.O. Box 91, Lovington IL 61937*. Or call for info during the day, (217) 543-2178 and eves. at (217) 873-5287. No VE exams this year.

CANFIELD, OH The Twenty Over Nine Radio Club Inc. will sponsor their 14th annual Hamfest Computer/Electronics Flea Market at Canfield Fairgrounds, Rt. 46, Canfield OH, 8 a.m.-3 p.m. Handicapped parking and facilities available. Gate admission \$5, under 12 years admitted free with an adult. Outdoor flea market space is free with admission. Dealer/flea market setup begins at 6:30 a.m. Inside tables \$10 per table, gate admission not included. Inside tables guaranteed until 9 a.m. with reservation/fee in advance. Others on a first-come, first-served basis. Uniformed and plainclothes security will be present. Alcoholic beverages, firearms, and questionable or immoral material are strictly prohibited on the fairgrounds property. Mobile check-in and directions until 1 p.m. on 147.315(+) or 443.225(+); alt. 145.275(-). For further info contact *Sharon Spencer, 424 Peffer St., Niles OH 44446, tel. (330) 544-3666; or Dave Mellot, 2895 Penny Lane, Youngstown OH 44515, tel. (330) 793-0816; or Don Stoddard N8LNE, 42 S. Whitney Ave., Youngstown OH 44509, tel. (330) 793-7072*. Mail registration with an SASE and check/money order payable to *20/9 Amateur Radio Club Inc., 42 S. Whitney Ave., Youngstown OH 44509* no later than April 15th.

NEW CASTLE, DE The Penn-Del ARC will hold their annual hamfest and host the 1998 ARRL Delaware State Convention 9 a.m.-3 p.m. at the Nur Temple on Route 13 North in New Castle DE, 1/4 mile north of the Route 13 and 40 intersection. Admission \$5 at the door, no advance. Under 12 years free. Tables by reservation only with payment to *Penn-Del Hamfest 98, P.O. Box 1964, Boothwyn PA 19061*. Tables \$15 with electricity or \$10 without, includes vendor admission ticket. Setup at 6 a.m. Tailgating is \$10 per space on a first-come, first-serve basis. Features: certified

SKYWARN spotter training class; ARRL and club leaders forum; special guest speaker Ed Hare W1RFI from ARRL headquarters will present a seminar on the new FCC RF exposure regulations. He will also be available to assist with the completion of evaluation forms. For more info contact *Hal Fronts KA3TWG at (302) 793-1080, or E-mail [hfrantz@magpage.com]*. Also, find up-to-the-minute info/lodging and vendor forms at [<http://www.magpage.com/penndel>].

MAY 2

CADILLAC, MI The Wexauke ARC will hold their annual hamfest 8 a.m.-1 p.m. at the Cadillac Middle School in Cadillac MI. VE exams for all classes at 1 p.m. Admission \$5; 8 ft. table \$6. Setup at 6 a.m., table holders only. Talk-in on 146.98 rptr. Contact *Dan KE8KU, Wexauke ARC, P.O. Box 163, Cadillac MI 49601. Tel. (616) 775-0998; E-mail [ke8kudan@juno.com]*.

MAY 2-3

ABILENE, TX The Key City ARC will sponsor a hamfest at the Abilene Civic Center from 8 a.m.-5 p.m. Sat., and 9 a.m.-2 p.m. Sun. Free parking. VE exams. Wheelchair access. Tables \$6 each. Pre-registration \$7 (must be received by Apr. 28th), \$8 at the door. Talk-in on 146.160/.760. For reservations and info, contact *Peg Richard KA4UPA, 1442 Lakeside Dr., Abilene TX 79602. Tel. (915) 672-8889*.

MAY 3

YONKERS, NY The Metro 70 cm Network will hold another Giant Electronic Flea Market at Lincoln High School, Kneeland Ave., Yonkers NY, 9 a.m.-3 p.m., rain or shine. Free parking. No tailgating. Indoor flea market only. VE exams. Vendors: \$19 first table, \$15 each add'l table. All tables 30" x 5', or bring your own tables at \$14 for a 6 ft. space. At the door \$25 each table, \$20 for a 6 ft. space. Full payment is due with registration. Mail reservation payments to *Metro 70cm Network, 53 Hayward St., Yonkers NY 10704*. Spaces will not be held past 9 a.m. No refunds unless prior notice of cancellation has

been received 72 hrs in advance. Donation \$6, kids under 12 free. Table setups at 7 a.m. Free coffee, door prizes, grand prize drawing at 1:00 p.m. For registration, or vendors' or buyers' information, call *Otto Supliski WB2SLQ, (914) 969-1053*. Talk-in on 449.425 MHz PL 156.7; 223.760 MHz PL 67.0; 146.910 MHz; and 443.350 MHz PL 156.7.

MAY 9

MANITOWOC, WI The Lakeshore Hamfest, Electronics & Computer Swapfest will open its doors at 8 a.m. at the Manitowoc County Expo Center, intersection of Hwys 42-151 and I-43 on County Hwy. Rd. Fri. night setup for vendors until 10 p.m.; also starting at 6 a.m. Sat. morning. Accommodations for vendor drive-ins. Advance tickets \$3, \$4 at the door. Reserved 8 ft. tables \$6 each. Electric outlets \$5 each. VE exams for all classes at Silver Lake College (Hwy. 151); test registration closes at 9 a.m. DXCC field checking at the expo. For info call *Glenn, (920) 684-7096, any time, or Red, (920) 684-9097, days*. Talk-in on 146.61(-) or 147.03(+). Send reservation payments with an SASE to *Mancorad Radio Club, P.O. Box 204, Manitowoc WI 54221-0204*.

MAY 14-17

DAYTON, OH The QRP Amateur Radio Club International will present their "Four Days in May" 1998 Conference at the 1998 Dayton hamvention®. Amateur radio QRP presentations, workshops, and demonstrations will be the focus of the all-day Thursday QRP Symposium to be held at QRP ARCI headquarters, the Days Inn Dayton South. Registration is \$10 if prepaid by May 1st and \$12 after that or at the door. "At the door" registration may be limited by sellout. Registration will cover a full day of QRP Symposium activities, coffee, Symposium bag stuffers and a complimentary copy of the FDIM 98 QRP Symposium Proceedings. Make payment to QRP ARCI, and send with an SASE by May 1st to *Cam Bailey KT3A, FDIM Symposium Registration, P.O. Box 173, Mt. Wolf PA 17347*. E-mail queries to [kt3a@juno.com]. The QRP-ARCI Awards

Banquet, Fri. May 15th, is being hosted by FDIM Banquet Chairperson Scott Rosenfeld NF3I. Please send an SASE and your \$22 banquet ticket fee (US check, money order, international money order) made payable to QRP ARCI (by May 1st) to *Scott Rosenfeld NF3I, QRP ARCI Banquet Tickets, 4015 Sparrow House Lane, Burtonsville MD 20866-1333*. E-mail queries for more info to [ham@w3eax.umd.edu]. The FDIM QRP Vendor Social will be held Fri. evening May 15th, with Jim Stafford W4QO, QRP ARCI VP, as the host. For registration info please contact *Jim at 11395 West Rd., Roswell GA 30075, or E-mail [w4qo@amsat.org]*. The Days Inn Dayton South will be the 1998 FDIM QRP headquarters and a special block of rooms has been secured. Please contact *Hank Kohl K8DD, 1640 Henry St., Port Huron MI 48060; E-mail [k8dd@tir.com]* regarding availability of rooms. QRP Symposium presenters, please submit your QRP technical manuscripts to *FDIM 98 Technical Paper Chairperson Ken Evans W4DU, 848 Valbrook Court, Lilburn GA 30047; or E-mail [w4du@bellsouth.net]*.

JUL 26

HONOLULU, HI In celebration of their third wedding anniversary, a grand Ham-Boree is being planned by Gordon Crowhurst G4ZPY and Brenda in the form of a big get-together of hams and their partners for an evening meal in Honolulu. They would like to put a face to a callsign, a face to a name, of their many friends and acquaintances all over the world. For those who are interested, there are a lot of nearby mountains for DXing on the Pacific Rim. For more info contact *G4ZPY Paddle Keys International, 41 Mill Dam Lane, Burscough, Ormskirk, L40 7TG England. Tel./FAX (44) (0)1704-894299* any-time until 2300, but not between the hours of 1600-1830 local time. Everyone must make their own holiday arrangements themselves and pay for their evening meal. Please R.S.V.P. so that a suitable location may be arranged for the get-together.

Continued on page 85

Hamtronics' CC432-5 Receive Converter Kit

Straightforward building, modest price.

Larry Antonuk WB9RRT
P.O. Box 452
Marlborough NH 03455

One of the main attractions of amateur radio is the fact that it's a multitude of sub-hobbies contained within a single hobby. Most hams start out chasing DX or doing two-meter work, but it isn't long before they move off to public service, satellites, moonbounce, construction—whatever catches their attention. This fact makes for an exciting hobby, and explains why it's fairly easy to remain interested in ham radio for your whole lifetime.

Of course, this wonderful diversity has its downside. How do you pay for all that stuff? Many a ham has found himself feeling like a small child, clutching a nickel in a candy store. So many choices, so little funds. On first glance this seems to fly in the face of the classic ham stereotype—frugal to a fault. How is it that hams can be so notoriously cheap if they have to buy a brand new rig every time they decide to explore a new segment of the hobby?

As you might imagine, hams have already figured a way out of this dilemma. The concept is fairly simple. Imagine yourself going out and buying a new HF rig. About a year later you buy a 220 MHz transceiver, and then you pick up a 440 MHz rig. You have

all three of them lined up on a shelf in your ham shack. As you sit there looking at them a couple of things become obvious.

First, you note that you can only talk on one of them at a time. Second, you can see that the three radios are pretty similar. They all have frequency displays, volume controls, speakers, microphones, and other components in common. As a matter of fact, you see that the 220 MHz and 440 MHz rigs are practically identical—they just work on different frequencies. The conclusion is simple—you just paid for three sets of these "common controls" when you really only needed one.

Attacking the problem from the other direction, suppose that you didn't quite have the funds to get that 440 MHz rig. What if you could have just purchased the part you needed—the frequency stuff—and used the common stuff from one of the radios you already had?

So, what's a converter?

Converters have been used for years, mainly to allow a ham to take an existing rig (usually 10 meters) and put a box in front of it that converts the re-

ceive and transmit frequencies to another band (usually VHF or UHF). This gives the user the same functionality of the HF radio (memories, scanning, etc.) but simply translates the frequencies to a new band.

The converter concept has been used for many years as an external add-on, and also as a design concept in some receivers. More recently some manufacturers have released mobiles that allow different frequency modules to be used with the same control head—a slight twist on the original converter concept.

The CC432-5 by Hamtronics is one of several receiving converters built by this manufacturer. The model chosen depends on the frequency of operation desired. For instance, the CC432-5 accepts an input range of 435–437 MHz, and outputs a signal from 28–30 MHz. If you already have a two-meter transceiver, you can order the CC432-4, which accepts an input from 432–436 MHz, and creates an output signal from 144–48 MHz. If you are primarily interested in ATV you can get the CC432-9. This unit accepts 439.25, and translates it to 61.25 MHz (channel 3). If UHF is not your cup of tea, Hamtronics



Photo A. The Hamtronics CC432-5 Receive Converter.

offers a line of VHF receive and transmit converters as well.

How does it work?

The theory of operation of the converter is fairly simple. A converter is simply an extra mixer and local oscillator placed ahead of the existing radio. In the case of the CC432-5, the local oscillator in the converter is running at 407 MHz. Signals enter the converter in the desired frequency band, and are offset by the value of the mixer. For instance, a signal entering the converter at 436.5 MHz will be mixed with the 407 MHz local oscillator, producing a difference frequency of 29.5 MHz, which can be received by the 10-meter rig attached to the converter.

If you remember your superheterodyne receiver basics you'll recall that the sum frequency is produced as well as the difference frequency. You'll also see that any number of input frequencies can be entering the converter at a given time. Most of these signals are unwanted, and are dealt with by the use of input and output filters. The CC432-5 has a built-in GaAsFET RF amplifier which is tied to a mixer via a triple-tuned circuit. This provides selectivity by allowing only the desired signal band to reach the mixer. The output of the mixer passes through an over-coupled double-tuned tank circuit. This circuit selects a band that corresponds only to the difference frequencies—the sum and the original two inputs to the mixer are effectively filtered out. (The over-coupling produces a circuit with a wider bandwidth, so it won't be necessary to retune any of the circuitry over the entire range of operation.)

The local oscillator input to the mixer is actually the result of a chain of three triplers. The crystal operates in the 14–6 MHz range, depending on model, and the third harmonic is passed through two more tripler circuits to produce the desired injection frequency. Once again, double-tuned circuits are used to ensure that the injection frequency is pure.

As with any receiver, the local oscillator is actually a very low powered transmitter. It is always important to make sure that the oscillator frequency stays where it is needed, and doesn't leak out into the outside world. For instance, if the 407 MHz injection frequency were allowed to travel back out the converter input, it could interfere with licensed users in the 407 MHz region. This situation is prevented by the use of the double-tuned circuits mentioned earlier, the use of a preamp stage, and also by the quality of components used by Hamtronics. Bypass capacitors and ferrite beads are used to decouple the stages. A high quality PC board with a ground plane aids in the shielding. Additional shielding is used to prevent the RF amplifier stage from picking up any radiation from the mixer section. Power is passed to the unit via a feedthrough capacitor. All of these minor enhancements join together to make the CC432 a very stable and interference-free converter.

Putting it all together

Construction of the CC432-5 was fairly straightforward, and should be no trouble to anyone with a moderate amount of kit-building experience (two or three simple kits). The kit uses quite a few surface mount devices (SMDs) but only in the form of chip caps and resistors, which are quite easy to solder in.

The kit uses two FETs for the RF amplifier and the mixer, as well as three standard 2N3904s for the injection multiplier chain. The FETs have the potential for static damage, so a brief list of precautions is spelled out in the instructions.

The Hamtronics manual is typical of their other products—descriptive enough to do the job, but not insulting. For

instance, the precautions about static are followed by a fairly detailed description on how to mount the FETs. Attention is given to orientation, getting the right FET in the right slot, avoiding excessive heat, and bending the leads the right way. On the other hand, you're then directed to "Install the six small variable ceramic capacitors and the one piston variable capacitor, orienting them as shown." This is followed by tips on how to best install the SMD chip caps and resistors, probably with the assumption that most builders haven't used too many SMDs before.

Lining it up

Alignment of the converter is simple, and can be done with a DC voltmeter. A signal source is required, which can be a signal generator or even a strong off-the-air signal. The alignment consists mainly of peaking the coils in the injection chain, followed by a tune-up of the last multiplier, mixer, and RF amp for maximum signal passed to the receiver. The crystal is "netted" as a final step, which makes sure your output signal will exactly follow the converter input (minus the offset).

Although no special equipment is needed for alignment, a 0.060-inch square alignment tool is needed for all six variable inductors. The proper tool must be used with these slugs—they are quite prone to cracking if a substitute tool is used—for instance, a straight-blade alignment tool jammed in on a diagonal (trust me on this one). This tool is becoming more common in amateur, commercial, and consumer electronics. If you don't have one already you can order one from Hamtronics.

Getting it on the air

Operation of the converter is simple, since there are no controls! You already know how to use your 10-meter transceiver, so once you hook up the converter you'll know how to use your 432 MHz receiver. One point to remember is that the CC432-5 is a receive converter only—a separate unit is required to convert the transmitter side of the transceiver. This is normally accomplished

with separate outputs from the HF rig, or a TR relay setup if you're using a low-cost 10-meter rig. When first trying out the receive converter, however, keep in mind that it won't enjoy having any power accidentally blasted into the mixer—the results could be fatal. My initial tests were performed with the microphone removed from the 10-meter rig. That way I would be unable to sit on the mike and accidentally key the transceiver into the converter, despite my best efforts to goof things up.

The unit I built tested out fine on the bench, and I even had time to drive up on one of our local mountains during a recent VHF/UHF contest and "read the mail." This was very successful as I heard lots of stations—but pretty frustrating, since I hadn't yet built my transmit converter! (In retrospect, it might make more sense to build the transmit converter first. That way you won't have anything to listen to while you're working on the receiver, which could be less distracting than the other way around!)

An aesthetic viewpoint

My single criticism of the CC432-5 concerns the power connector. As mentioned earlier, power is fed to the unit via a feedthrough capacitor. This prevents any RF that might have found its way onto a power lead from getting back out of the unit where it could interfere with another service. A good idea, but the only way to attach to this lead is to solder a wire directly to it. The feedthrough is located dead center on the front of the unit between the input and output BNC connectors, and having a power lead soldered to the cap at this point is not the most appealing solution from an aesthetic standpoint. Of course, this is probably the only way to make a true RF-tight container—as soon as you punch a hole for a Molex™ connector you violate the integrity of the enclosure. In addition, the box is most likely going to be used tucked behind a transceiver somewhere, rather than displayed on a shelf. Still, if this connection (or all three, for that matter) could exit the box on the rear it would make for a nicer-looking station.

The Hamtronics CC432 converters present an economical method for expanding your ham horizons. Inexpensive and easy to build, they allow you to make the jump to other bands and other segments of the hobby. The quality of the units is outstanding—the finished board has the look and feel of a piece of commercial gear, rather than an amateur device. Any ham should have no trouble getting these kits on the air, and they range from \$49 for the kit alone, to \$79 for the kit with case, to \$99 wired-and-tested in a case.

Hamtronics converters are available from Hamtronics, Inc., 65-D Moul Road, Hilton NY 14468-9535. E-mail: [jv@hamtronics.com]. Web site: [www.hamtronics.com]. You can request a free catalog or view the entire catalog on their Web site.

**24 DIFFERENT PANELS
PRE-PUNCHED FOR
POPULAR CONNECTORS**

**MAKE TEST
FIXTURES QUICKLY!**
PANELS ARE 0.040" RAW ALUMINUM

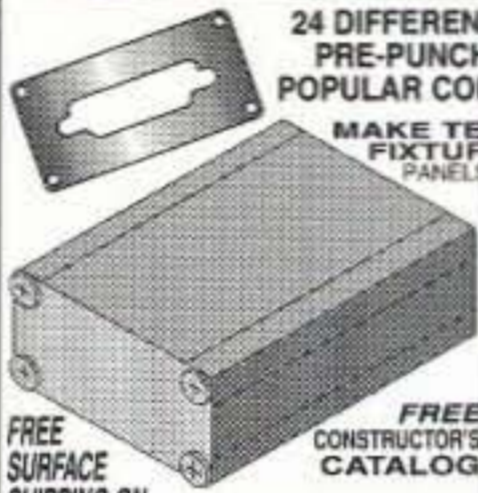

MODEL	W x D x H in.	PRICE
LAB-1	1.5 x 2.0 x 0.75	3.75
LAB-2	1.5 x 4.0 x 0.75	4.50
LAB-3	1.5 x 6.0 x 0.75	5.25
LAB-4	2.0 x 2.0 x 1.0	4.00
LAB-5	2.0 x 4.0 x 1.0	4.75
LAB-6	2.0 x 6.0 x 1.0	5.60
LAB-7	2.0 x 2.0 x 1.5	4.10
LAB-8	2.0 x 4.0 x 1.5	5.00
LAB-9	2.0 x 6.0 x 1.5	6.00

FREE SURFACE SHIPPING ON PREPAID ORDERS (CONT. U.S., CANADA & MEXICO)
FREE CONSTRUCTOR'S CATALOG

ORDER BY DECEMBER 31, 1997 AND SAVE 20% OFF YOUR TOTAL!
MUST MENTION #ST97 TO RECEIVE DISCOUNT
\$30.00 MINIMUM ORDER AFTER DISCOUNT

ORDERS 800-634-3457 ■ FAX 800-551-2749
OFFICE 702-565-3400 ■ FAX 702-565-4828
SESCOM, INC. 2100 WARD DR., HENDERSON, NV 89015
SESCOM, INC. is not responsible for inadvertent typographical errors and prices and specifications are subject to change without notice.

CIRCLE 167 ON READER SERVICE CARD

THE ORIGINAL WD4BUM HAM STICK™ ANTENNAS for HF MOBILE OPERATION \$19.95 each

The only lightweight HF mobile antenna recommended by noted author Gordon West, WB6NOA

- Monobanders for 75 to 6 meters.
- Very rugged fiberglass & stainless steel.
- Telescopes for easy adjustment.
- 3/8 x 24 TPI base fits most mounts.
- Low profile & low wind load.
- Needs no springs or guys.
- Complete tuning & matching instructions included.
- Approximately 7 ft. tall.
- 600 watts.

Cat. #	Band	Cat. #	Band
9175	75 meters	9115	15 meters
9140	40 meters	9112	12 meters
9130	30 meters	9110	10 meters
9120	20 meters	9106	6 meters
9117	17 meters		

NEW ENHANCED DISCONE SCANNER ANTENNA Only \$36.95



- 800 To 900 MHz enhancement.
- Transmit on 146, 220, and 440 amateur bands.
- Rated to 150 Watts.
- Compact, will fit in 36" x 36" space.
- Receives all AM-FM & SSB frequencies.
- Gain improves with frequency increase.
- Mounts to any vertical mast 1" to 1 1/2".
- Aluminum mount & elements.
- 8 cone & 8 disk elements—same as other discones selling for nearly 3 times our price.
- Accepts standard PL-259 connector.
- For type "N" connector add \$5.00.

Lakeview Company, Inc.

3620-9A Whitehall Rd., Anderson, SC 29626 • 864-226-6990
FAX: 864-225-4565 • E-Mail: hamstick@hamstick.com • www.hamstick.com

ALL 100% MADE IN USA Add \$7 per order S/H

MOBILE COLINEAR ANTENNAS

THE ULTIMATE PERFORMER

- Honest 4.5dB gain.
- 1000 watts DC.
- 17-7 ph stainless steel top sec.
- Rugged fiberglass base station.
- Base fitting is std. 3/8 x 24 TPI.

Length
9007 - 146 MHz 7'2" • 9038 - 220 MHz 4'9"
9440 - 440 MHz 2'5"

\$19.95

Base station
version available **\$29.95**
9007-B • 9038-B • 9440-B

Tri-Magnetic Mount MODEL 375

Only \$39.95



Now with no-rust
all stainless steel
hardware

- Holds all Hamstick Antennas and many others.
- Over 400# of holding power.
- 12" X 14" foot print.
- 3/8 x 24 thread mounting.
- 15' RG 58 coax w/PL-259.
- No rust aluminum construction.

CIRCLE 275 ON READER SERVICE CARD

FREE!

NEW CATALOG

CALL TOLL FREE: 1-800-JAN-XTAL

**Quality Crystals
and Oscillators for:**

AMATEUR BANDS • CB • MARINE VHF
SCANNERS • MICROPROCESSORS • PAGERS
P.O. Box 60017 • Fort Myers, Florida 33906
VISA (941) 936-2397

JAN Crystals

CIRCLE 242 ON READER SERVICE CARD

HamCall™ CD-ROM

U.S. & International - Over 1,454,000 listings



**HamCall™ has been rated
one of the "top 100" CD-
ROM's by PC Magazine!**

The HamCall CD-ROM allows you to look up over 1,454,000 callsigns from all over the world, including over 300 call areas. Over 118,000 new and updated international listings, including Australia!

The same CD works in DOS, Windows 3.x, Windows 95, and Mac. On a PC running Windows or DOS, you can look up hams by call, name, address, city, state, ZIP, call sign suffix, county, and now **soundex** last name searching. PC's can also view photographs, **edit** records (now including fax number), and calculate **beam heading** and **distance**. Macs can retrieve by call, last name, and ZIP.

- Displays precise latitude, longitude, and grid square for almost every U.S. and DX call.
- Calculates beam heading and distance from your station.
- Enhanced label printing for Windows. Select printer & font & print any size label. Label size, margins, columns, and rows are fully configurable. Also supports copy and paste.

Also on HamCall are over 143,245 cross references from old to new calls, over 3,400 photos, over 46,256 e-mail addresses, 15,000 vanity calls and much more.

HamCall price is still \$50.00 plus \$5.00 shipping U.S., \$8.00 international.

BUCKMASTER
6196 Jefferson Highway
Mineral, VA 23117
e-mail: info@buck.com
540-894-5777 • 800-282-5628 • 540-894-9141 (fax)

CIRCLE 56 ON READER SERVICE CARD

Joy's "Loud Enough" Metronome, Part 1

Another fun project from Mr. Gizmo.

Evert Fruitman W7RXV
2808 West Rancho Drive
Phoenix AZ 85017-2646
[fruitman@asu.edu]

Several years ago, my daughter's music teacher sent us on our way with what she thought was just an offhand request: "Oh ... and please bring a metronome to your daughter's music lesson next week. Thank you ..."

A quick look at a music supply catalog showed metronomes ranging in price from \$20 to almost \$200. That included the older-style mechanical metronomes with the upside-down pendulums. I rarely buy something I can build, so once I'd decided that one week gave me enough time to make a metronome, I was off and running ... or should I say off and ticking?

Some of the microprocessor-based units can put an accent on whatever beat you want, as well as let you pick practically any number of beats per minute. However, I felt that it would be too inconvenient trying to hold one of those to one ear and play the flute or the piano at the same time. You have to hear the precision pulses in order to use them.

Also, the pulses have a somewhat musical sound, something like a note

that got cut off in midstream. That has drawn unfavorable comment from several musicians I've talked to, including those who, for lack of something better, use one of those shirt-pocket-sized units. Of course, their relatively small size is a convenience, and sometimes a consideration.

Computerized cure?

The children had already complained that with other electronic metronomes they could not hear over the piano, even with the metronome sitting on top of the piano right in front of them.

A quick but temporary fix for that came in the form of a BASIC program fed into an old computer which drove an audio amplifier. That gave the speaker enough volume, but it was somewhat inconvenient to hook up. Wires all over the music room and questions about how to get the program running made me look for a better answer.

Digital devices

Countdown chips, dividers, and amplifiers could be combined in a circuit

that would give a louder metronome with adequate volume, but the circuit seemed too complex for what we wanted. If we were going to do all of that, why not just go buy one of the credit-card-sized wonders and hang it on an amplifier? Then I remembered some circuits that I had used once before. They worked, but with some limitations. It seemed that with some modification, one of those circuits would meet this need.

Early transistorized systems

In a 1964 edition of their *Transistor Manual*, General Electric published a couple of metronome circuits. **Figs. 1** and **2** show them in slightly modified form.

The UJT (unijunction transistor) circuit, **Fig. 1**, looked good with its adjustments, but a quick test at the workbench showed it a bit short on volume. A 22.5-volt battery gave its own problems. 15 penlight cells or three nine-volt batteries didn't appeal to me, especially since they did not make it that much louder. Besides that,

I usually have loose transistors in the spare parts box, but it would take extra effort to find a UJT—another trip to the store, and they're not all that easy to find; several years ago, some of the major semiconductor manufacturers quit making them.

The complementary circuit, **Fig. 2**, gave more volume—but try to find a small three- to four-ohm speaker today. Without a good supply of output transistors, it became impractical trying to use the circuit with an eight-ohm or higher-resistance speaker. Sometimes it worked for a while, and sometimes I had to change the output transistor. Still, the circuit had enough good points to cause me to give it a closer look.

Hang-ups

When the circuit hung up due to a wrong-value R, C, or speaker, then the output transistor, Q2, would burn out. The original circuit used germanium transistors and a three- to four-ohm speaker. The circuit worked as originally published. However, when this circuit hangs up, it causes the output transistor to exceed its power/current ratings.

Substituting heavier-duty silicon transistors seemed like a good starting point. When the circuit misfired, though, it still got Q2 hot under the collector. A little circuit analysis gave some insight into the problem and how to get around it.

In **Fig. 2**, turning on the power starts the capacitor charging through the speaker, R4, and R5. When the voltage at the junction of the speed control, the capacitor, and the base reaches about 0.6 volts, Q1 turns on. It starts conducting current through its emitter-collector circuit and the emitter-base junction of Q2.

Of course, running current through the emitter-base junction of Q2 turns it on. Q2 starts conducting current through the circuit consisting of its emitter-collector and the speaker. Since the collector of Q2 reaches essentially the same potential as its emitter, C2 discharges, thereby dropping the base voltage of Q1 below 0.6 volts and turning off Q1 and Q2.

With the capacitor discharged and the transistors off, the capacitor starts charging again, starting a new cycle: Q1 turns on, Q2 turns on, the speaker gets the full battery voltage for a few milliseconds, and the timing capacitor gets discharged.

Due to regenerative action, positive feedback, the turn-on of Q1, Q2, and the discharge of C1 all take place in milliseconds. Typically, the pulse lasts about four milliseconds (0.004). An oscilloscope shows that during much of that time, the high side of the speaker, the collector of Q2, reaches the applied voltage.

That makes Q2 an efficient switch. For a short time, it has tied the battery directly across the load. That also explains why this circuit can cook a transistor in the event of a malfunction in which Q2 stays turned on. It also points up the need for a big capacitor across Q2 and the speaker. C3 can deliver the high current needed to pulse the speaker.

With a 4.5-V battery and a three- to four-ohm speaker, the peak current can exceed one amp. I have measured it—it does reach 1.1–1.5 A under these conditions. When the battery starts getting tired, the circuit does peculiar

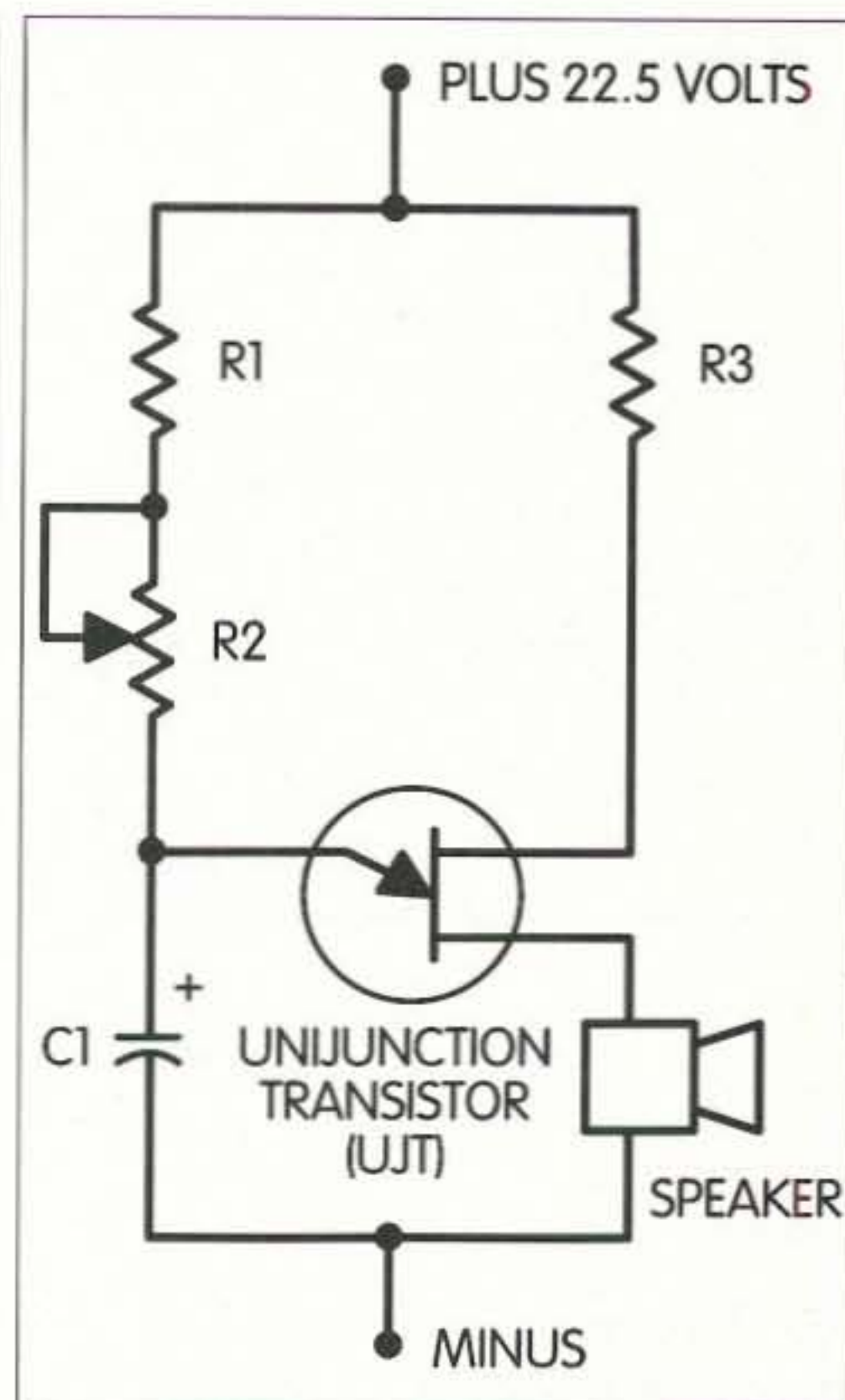

Fig. 1. This simple UJT metronome will work with a wide range of speakers but lacks volume. Additionally, it needs a higher voltage battery for best results. By putting the amplifier from **Fig. 3** on it, you may drop the battery voltage down to 9 V and run both parts on the same battery. Adding the power amplifier of **Fig. 3** gives more volume, but still this setup is not as loud as the system shown in **Fig. 4**.

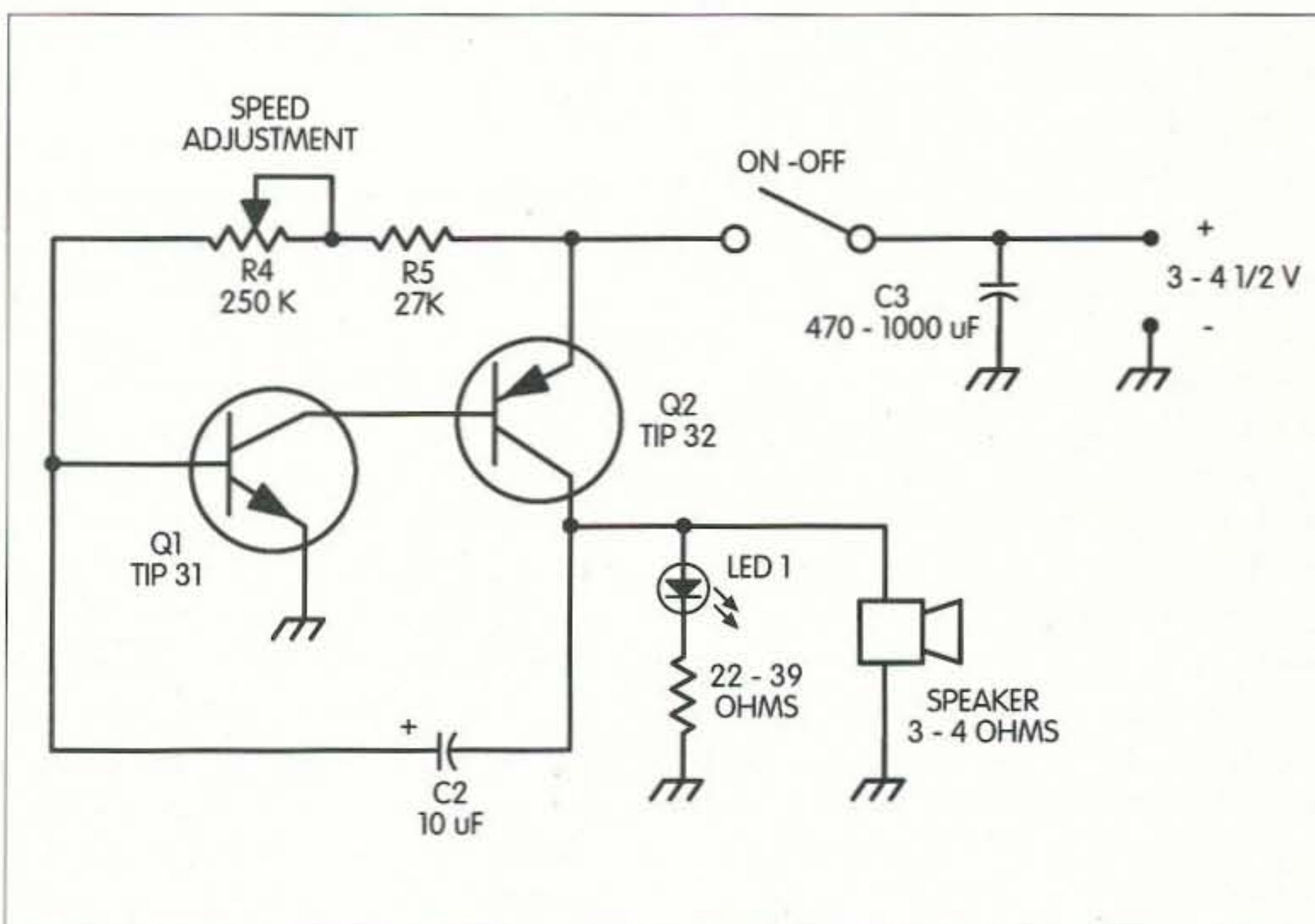

Fig. 2. This basic metronome works best with a 3–4 ohm speaker and 3–4 V. Although reliable, it lacks the volume needed for a player to hear it over the sound of many common solo instruments. The amplified version, shown in **Fig. 3**, gives a loud enough tock sound. C3 must go on the battery side of the on/off switch. Placing it on the instrument side causes a slow fade-out of the sound, with the pulses changing speed as the sound fades.

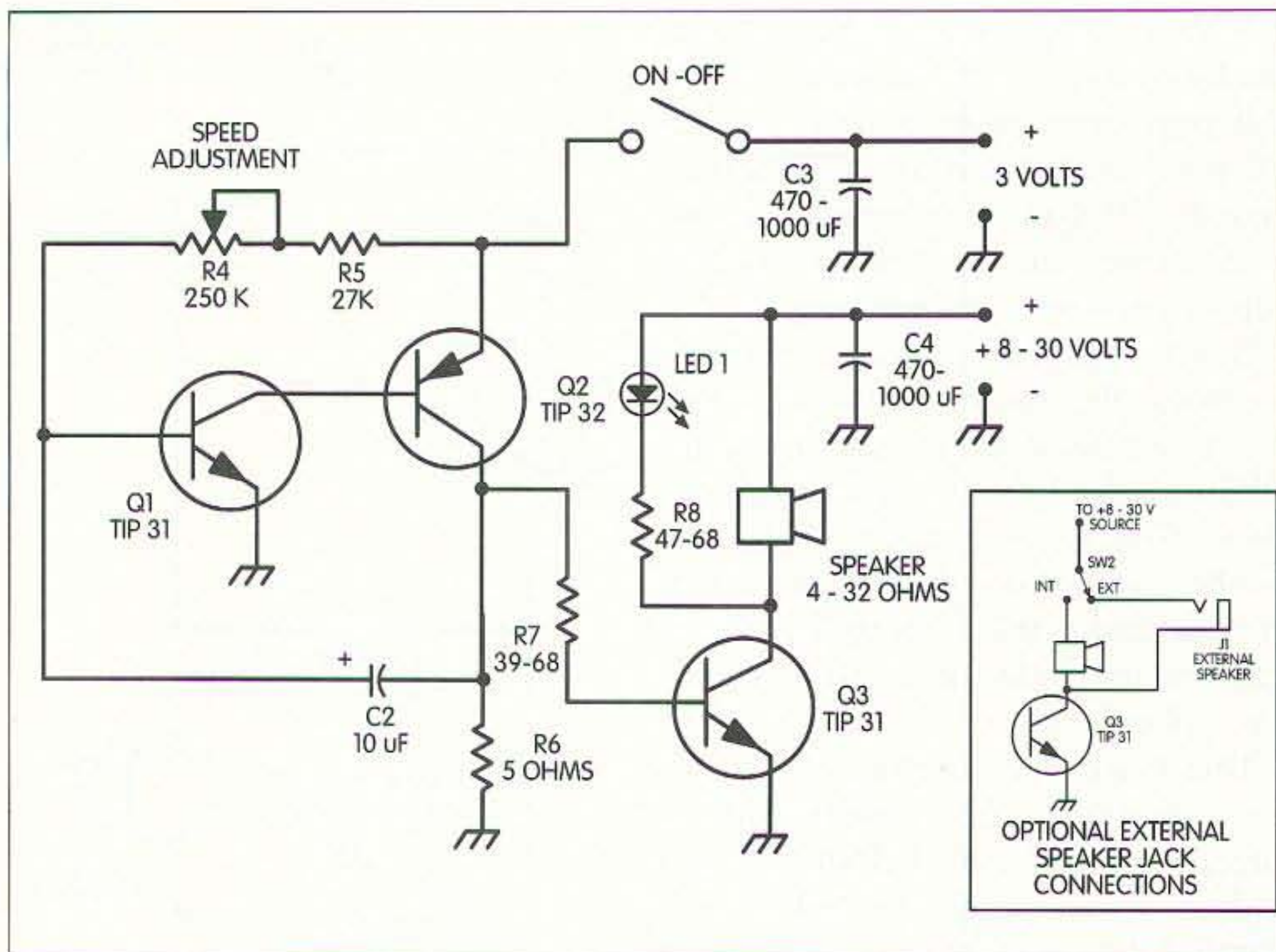

Fig. 3. Amplified metronome using complementary pair. Loud enough with external speaker; sometimes loud enough with just internal speaker. Smaller circuit shows one way to add the option of internal/external speaker selection. Instead of the switch, you could buy a closed-circuit jack for J1. Some people find the switch less confusing than the closed-circuit jack and much more reliable. With the addition of R6, R7, and Q3, you can use almost any available speaker and raise the power level by use of a higher-voltage battery. Since Q3 draws power only when it gets a pulse from Q2, you may use a simple on/off switch on just the first stage. Sometimes Q1 and Q2 will not operate properly with more than 3-1/2 V.

things. Do use C3. This circuit works well with three to four volts and a nominal four-ohm speaker. Most of the time it will work with as much as five volts if you keep the resistance in the collector of Q2 around four to five ohms; sometimes, it wants less resistance.

Exception to the rule

I made several of these metronomes. They used a five-volt regulator and five ohms for the collector load of Q2. All but one of them worked as expected. They delivered a nominal four-millisecond pulse and from 40 to 240 or more beats per minute. One of those metronomes hung up. It turned on Q2, which stayed turned on, until I interrupted the power connection. The heavy-duty silicon transistors can withstand the extra current caused by this overload condition. I checked everything, but I lost that round. I wound up putting another resistor across the five ohms from the collector of Q2 to

common. The total resistance equals about three ohms. The pulse runs about one-tenth as long as the other units. Since then, it has kept good time.

A fix

Dropping the voltage on that unit to three volts, with or without the extra resistor, the circuit never missed another beat. That unit went together with the extra resistor. The next metronome went together with a five-volt regulator followed by a three-volt regulator—see Fig. 5(a). You could save the time and trouble of the second regulator circuit by using an adjustable regulator, the LM317, as shown in Fig. 5(c). Photo A shows an etched circuit board with the two regulators. Since I wanted to save myself a trip to the store, I opted for the extra transistors. The simple two-transistor regulator cannot regulate well enough by itself to keep the three volts as stable as needed. So you need either the five-volt preregulator or the LM317.

Parts List for Fig. 3

R4	250 k pot (500 k with 470 k across will work but crowd high end)
R5	27 k 1/4 W (same for all resistors)
R6	4.7 Ω or 2x10 Ω in parallel
R7	39-68 Ω
R8	47-68 Ω
C2	10 μF 6 V tantalum *272-1436A 10/16
C3	470-1000 μF 6V *272-958 1000/16
C4	470-1000 μF 25 V (if battery no more than 22 V; if close to 28 V, use 35 V cap)
Q1, Q3	TIP31 NPN transistor *276-2017
Q2	TIP42 PNP transistor (TIP32 OK) *276-2027
LED1	red: *276-087 green: *276-069 use 470-680Ω for R8
J1	open circuit mini phone jack *276-251C
SW1	SPST toggle or slide
SW2	SPDT toggle or slide
Speaker:	Midland 21-392, junk box or Radio Shack 2-1/2 inch
Box :	3x5 file box or Radio Shack 270-223
Batteries:	six AA or three 9 V (typically one or two 9 V will do)
	*Radio Shack part number

Table 1. Parts list for Fig. 3.

Three-volt regulator

Fig. 5(a) shows the simple three-volt regulator. A 7805 regulator delivers five volts to the input of the three-volt regulator. The 4700-ohm resistor, R9, limits the current through the diode string, LED2, LED3, and D1, to a little less than 400 microamps: 0.4 milliamps.

The diode string will maintain a relatively constant voltage across the base of Q4. With low to medium current through them, the LEDs will have a relatively stable voltage across them.

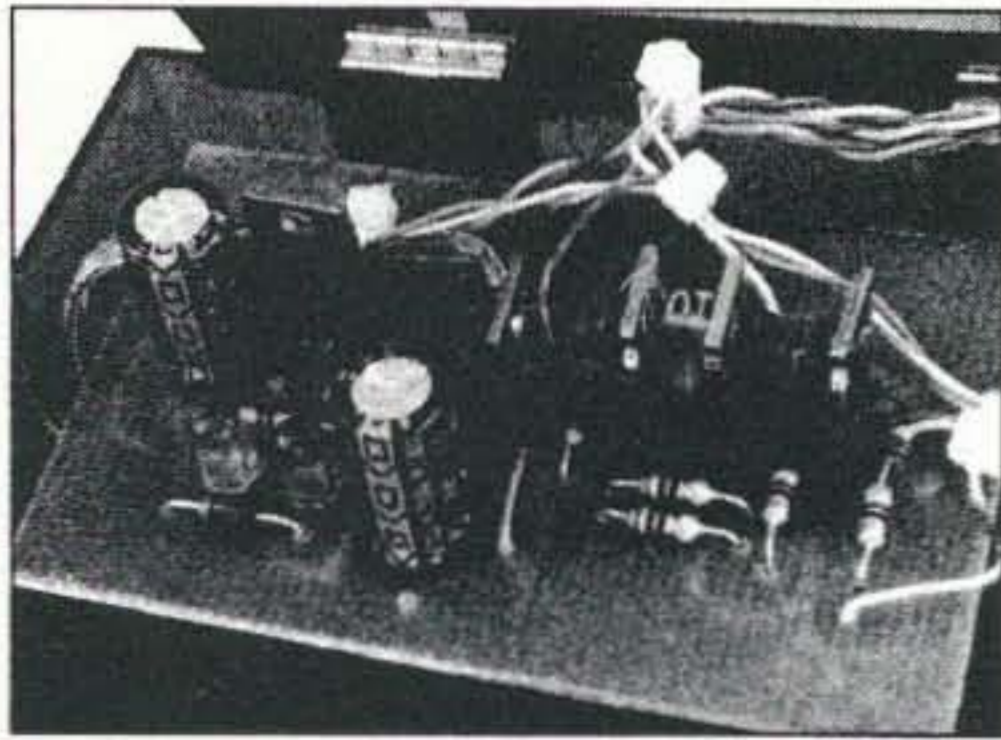

Photo A. Etched (taped) board in basic, bare-bones, blue-box metronome. Lower left corner: D1, LED2, LED3. Above that: R9 (4700 ohms). Top left: C4, 7805 regulator. Middle: Q4 (in back of C3), Q5, Q1, C2, Q2, Q3. Lower right: 47-ohm resistor to LED1.

The voltage drop across the LEDs drifts less with temperature and current changes than it will across a silicon power diode.

The voltage across the LEDs will run from around 1.2 to 1.8 V each. The drop depends upon the internal construction of the individual LED. The current through the LED will have some effect on the voltage drop. The total voltage drop across the diode string is just over four volts. You could replace the diode string with a 4.3–4.6-V zener diode.

The voltage from the diode string feeds the base of Q4. Q4 and Q5 make a Darlington pair. In this case, they are connected as an emitter follower. That applies the input voltage, minus the voltage drop in the two emitter-base junctions, to the load. The load is the complementary pair, Q1 and Q2.

Regulation

Since Q4 and Q5 have no way to sense changes in output voltage, they have no feedback from output to input and they cannot make the changes needed to maintain a constant output voltage when the input voltage makes a large change. An emitter follower like this will hold a relatively steady output voltage, but for this application it needs the preregulator in the form of the 7805.

Of course, you can avoid all of this fun by using the LM317, as in Fig. 5(c). Just set it to three to four volts and you are done with the power supply for the heart of your metronome, the complementary pair.

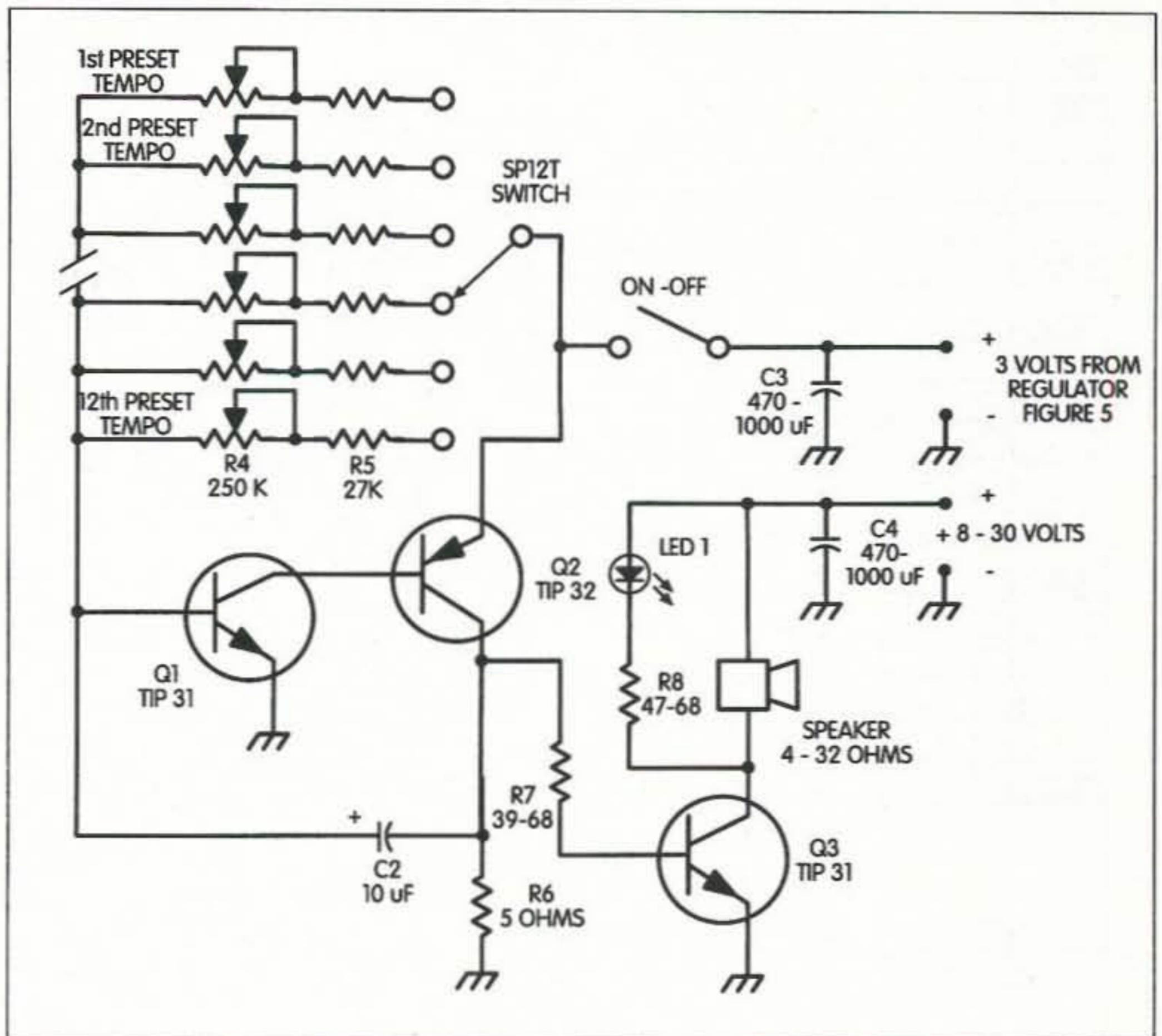

Fig. 3(a). Amplified metronome. Same as Fig. 3, but shows how to add presets. For simplicity, only six of twelve switch positions shown.

Parts List and Presets for Fig. 3(a)

For the presets, add these parts to the list for Fig. 3:

Switch	SP12T	8 presets plus variable, 11 presets possible
Trimmer Pots	Fixed	Beats/Minute (adjust trimmer as needed)
15 k	270 k	40
15 k	180 k	60
50 k	100 k	72 (or 73)
50 k	100 k	84
50 k	100 k	96
20 k	82 k	112
30 k	82 k	120
20 k	68 k	132

Table 2. Parts list and presets for Fig. 3(a). If you compare these values to those listed for the deluxe version, there may seem to be some inconsistencies. Chalk that up to the variations in the size of the available trimpots used in this model.

ISOTRON
ANTENNAS FROM 160-10 METERS

NO TUNERS
NO RADIALS
NO COMPROMISE
PRICES START AT \$49.95

SEVEN EXCELLENT REVIEWS
JUST DON'T HAPPEN BY CHANCE
CALL US FOR A FREE CATALOGUE

See review in 73, Oct. 1984; 73, Sept. 1985; 73, March 1986
CQ, Dec. 1988; W.R., Mar. 1991; 73, Nov. 1994; 73, Apr. 1996

ASK ABOUT OUR NEW ISOTRON 160C!

BILAL COMPANY
137 MANCHESTER DRIVE
FLORISSANT, COLORADO 80816
(719) 687-0650

CIRCLE 42 ON READER SERVICE CARD

All Aluminium

Chassis Kits	Rack Shelves
Cabinet Kits	Rack Equipment
Assembled Cabinets	Antenna Grounding Kits
Slope Box Kits	Tower Mounted Box Kits
UHF & VHF Antenna	Dipole Hangers
Power Divider Kits	Other Enclosures

Small sheets Aluminum and Brass
UHF / VHF Antenna Parts

Byers Chassis Kits

Charles Byers K3IWK
5120 Harmony Grove Road • Dover, PA 17315
Phone 717-292-4901
Between 6PM and 9:30 PM EST. Eves.
E-mail k3iwk@juno.com

CIRCLE 222 ON READER SERVICE CARD

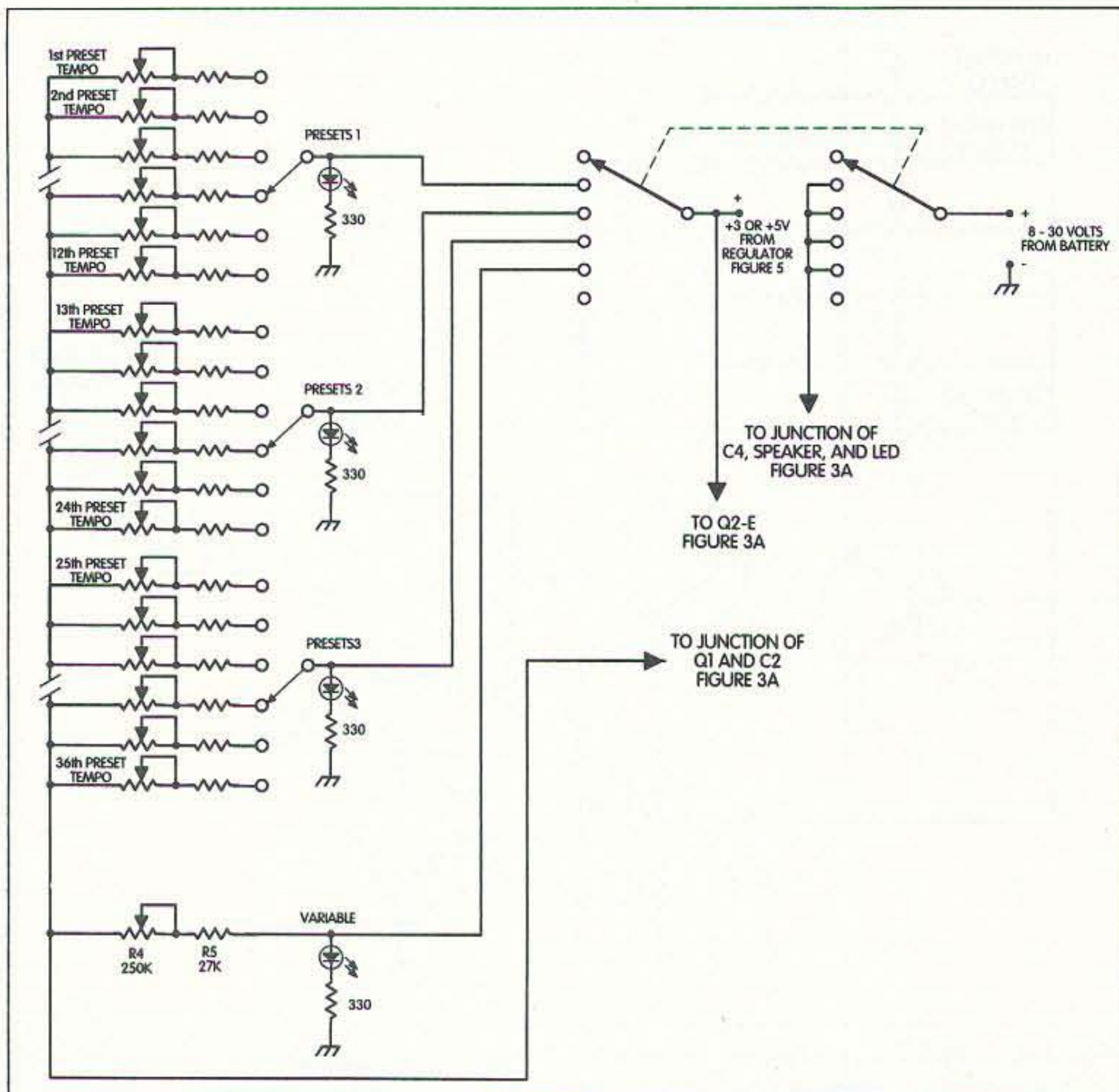

Fig. 3(b). Deluxe configuration with 36 presets plus a variable control. For external speaker, use wiring shown in Fig. 3. Switch positions: 1—off; 2—presets 1; 3—presets 2; 4—presets 3; 5—variable. Switch shown in position 1.

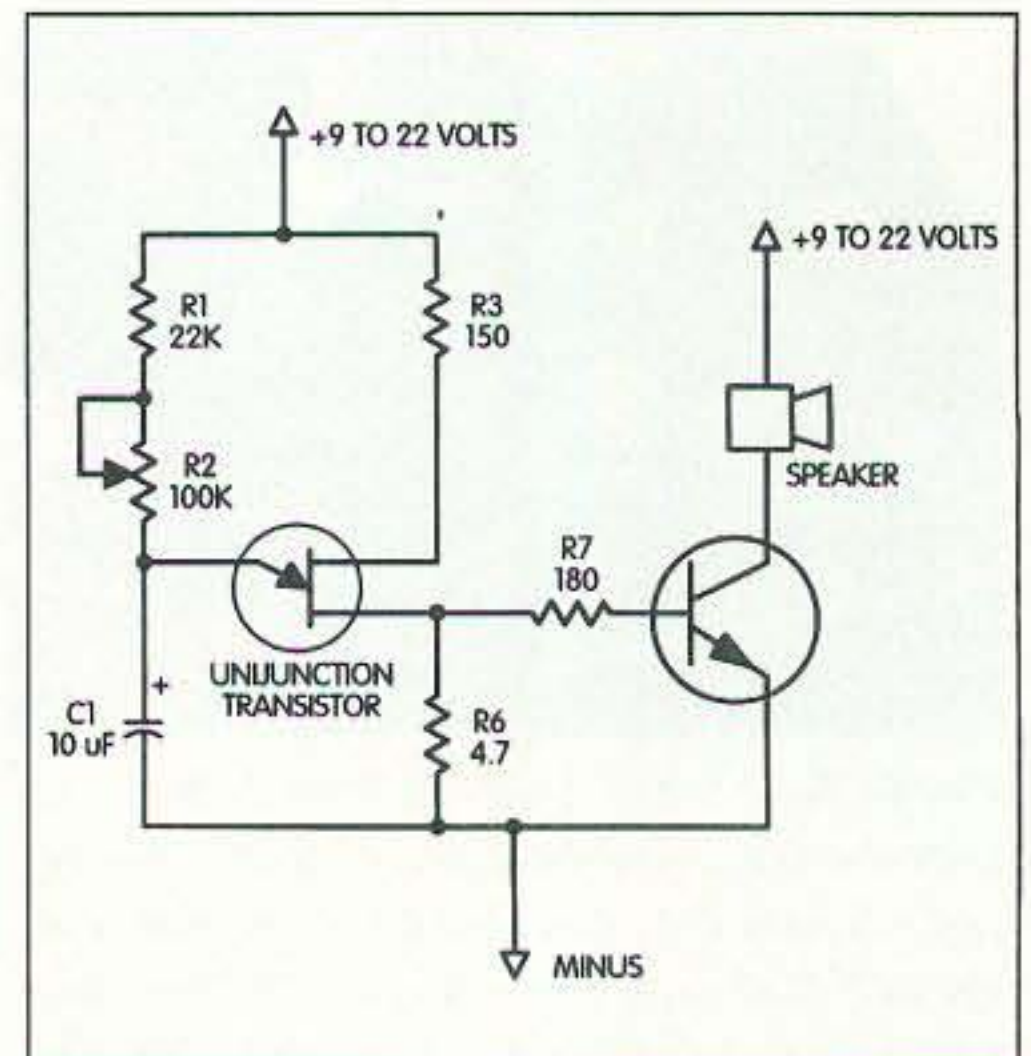

Fig. 4. Basic UJT metronome with booster amplifier gives more volume and will run on lower voltage than the basic circuit by itself. However, it still lacks a good, loud punch, and some of the major manufacturers have made UJTs harder to find by dropping them from their production lines.

able control. **Table 4** gives the standard beats/minute for metronomes. Since the switches have twelve positions, I added two more tempos to give an even three dozen. **Fig. 3(b)** gives the details if you are that ambitious. Depending upon your needs, you could make a metronome with any number of presets or, as in the case of the basic unit, none. Resetting a control to exactly the same place, in order to get the same tempo, is difficult at best. That is why I made Joy two metronomes with preset tempos. She and her students (now) like being able to get the same tempos each time.

Louder is better

I cannot say why the one circuit malfunctioned. Over the years that I have built this basic circuit, I have seen it hang up once in a while and take out Q2. I do not remember it giving a real problem as long as it had no more than three to four volts on the two transistors, Q1 and Q2, and a collector load no larger than four to five ohms. But staying within those limits did not always give a loud enough sound. That brings us to Q3 and getting rid of the problem of finding a three- to four-ohm speaker.

A substitute gives one way around the problem of finding a small three- to four-ohm speaker. You can find small (but

Another quick fix

You could put three power diodes, 1N4001s, in series with the output of the 7805, **Fig. 5(b)**. That would give the needed three to four volts. However, I mention it only in passing because I have used 1N400X diodes as temperature sensors and do not recommend them for this application. Certainly, if you can take a slightly less stable instrument, that would work. I do not consider this a precision instrument.

However, tests on the metronomes that I put preset times into repeated their settings within 1%. I try to go for the minimum parts to get the needed repeatability. **Photo B** [Ed. note: **Photos B, C, and D, and Tables 4 and 5, appear in Part 2**] shows a basic, bare-bones, blue-box metronome with eight preset times and a continuously adjustable range from too slow to too fast.

Photo C shows the final version Joy uses. It has all 34 of the standard tempos, switch-selectable, as well as the vari-

REPEATER HEADQUARTERS
 Make "Commercial Quality" repeaters from GE and Motorola Mobiles

- 45 Watt VHF Micor from \$99
- 40 Watt UHF Master II from \$199

Conversion Information Available!
<http://www.versatelcom.com>

VersaTel Orders: 800 456 5548
 COMMUNICATIONS Info: 307 266 1700
 FAX: 307 266 3010

CIRCLE 259 ON READER SERVICE CARD

BIOELECTRIFIER™
 EXPERIMENTAL MICRO-CURRENT SUPPLY
 Now FULLY ASSEMBLED with batteries and FINE SILVER (not stainless steel) electrodes

\$89.50 + \$2.50 S&H
 Beware of IMITATIONS!

ALSO...
 COLLOIDAL SILVER GENERATORS
 ZAPPERS, SILVER ELECTRODES, SEMI-KITS, etc.
 send SASE for information
 On the WEB: www.infocom.com/~thomil/

To order, send CHECK or MONEY ORDER to:
THOMAS MILLER, W8YKN
 314 South 9th Street
 Richmond, IN 47374
 Voice/FAX (765) 962-3509 thomil@infocom.com

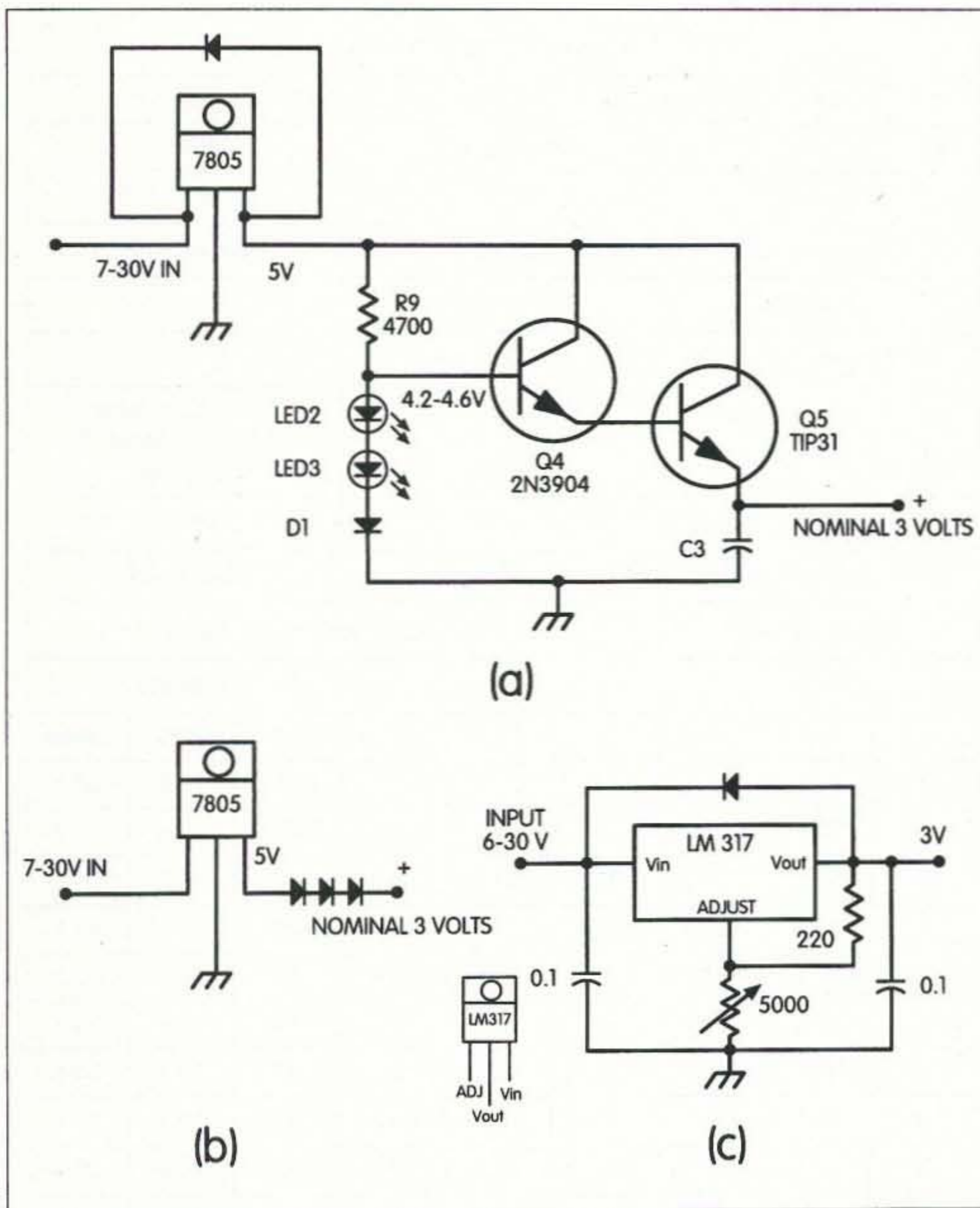

Fig. 5. Regulators, 3 V source. (a) 3 V regulator. Protection diode needed if 5 V is applied directly to complementary pair in Fig. 3. (b) Quick fix 3 V from 5 V regulator (not recommended here). (c) LM317 regulator.

costly) hi-fi speakers, but you do not want to spend more on the speaker than you do for the rest of the parts. You can make a substitute, though, with one or two 10-ohm resistors in parallel with an eight-ohm speaker.

Loud enough is even better

Connecting the resistors in parallel with an eight-ohm speaker gave 3.3–4.4 ohms where the circuit, Fig. 2, needed it. It looked good and played well, but wasted power in the resistors. Also, we wanted it louder—a lot louder. So, as Fig. 3 shows, we made several changes. I substituted two 10-ohm resistors for the speaker. That kept the first two transistors happy

most of the time as noted above. A transistor connected across the two resistors could drive any practically-sized available speaker.

An additional battery and the ability to connect a larger external speaker made the system reliable without serious risk of losing the output transistor, and it gave plenty of sound. It allows the use of speakers from four to 32 ohms, and it boosted the sound level enough so that Joy could hear it over the piano, my flute, and her five-year-old. This is several years, and several transistors, after the first request for a metronome. I wonder ...

Never one to leave well enough alone, I had to see how well the modifications would work on the UJT circuit.

G-P Antenna Base

MP-68 MAST BASE, makes ground plane antenna using combinations of AB-21-24 or MS-116-118 whip masts installed as three radiating elements plus one vertical. Center 3" dia ceramic feed-thru insulator has UHF connection and sockets for elements. Clamp on bottom for mount on 1.6" dia masts like AB-35 (RC-292) or MS-44 (AB-155). 13"Hx5"Wx5"D, 5 lbs sh. USED \$29.95
 AB-21, -22, -23, -24 masts; 24" long. Used .. \$3.25 ea
 MS-116, -117, -118 masts; 36" long. Used ... \$3.50 ea

Diode Assemblies

DIODE HEATSINK ASSEMBLY, six 1N3085 100 PIV 150 amp diodes on 1.9x9.3x4.8 heatsink, 4 lbs sh. #DHS6-3085, \$24.95
 #DHS6-5A10P, with six Sarkes ST5A10P 100 PIV 50 amp diodes; heatsink 2.6x8x4.5. \$12.95
 #DHS6-1815, with six MR-1815-SL 300 PIV 100 amp diodes; heatsink 2.6x9.4x4.8, 4 lbs sh. \$32.95

Prices F.O.B. Lima, O. • VISA, MASTERCARD Accepted.
 Allow for Shipping • Write for latest Catalog
 Address Dept. 73 • Phone 419/227-6573 • Fax 419/227-1313
 E-Mail: fairadio@wcoil.com
 Home Page: <http://alpha.wcoil.com/~fairadio/>

FAIR RADIO SALES

1016 E. EUREKA • Box 1105 • LIMA, OHIO • 45802
 CIRCLE 75 ON READER SERVICE CARD

CUBEX CO., INC.

40 YEARS OF QUALITY ANTENNAS
SKYMASTER H.F. KITS FROM \$275.95
PRE-TUNED H.F. QUADS FROM \$389.95
 Quad Antennas From 2 Through 40 Meters
2 METER 4 EL. PRE-TUNED \$49.95 + S&H
6 METER 2 EL. PRE-TUNED \$69.95 + S&H
 BEST PRICES ON DOUBLE BRAIDED "DACRON" ANTENNA ROPE
 visit our new web site <http://www.cubex.com>
 Write Or Call For Free Catalog
 7024 Southwest 21st Place, Unit D, Davie, FL 33317
 (954) 236-3663 FAX (954) 236-5576

CIRCLE 166 ON READER SERVICE CARD

DRAKE SW-1

The Drake SW-1 sets the stage for worldwide shortwave listening with ease, simplicity and clarity. The SW-1 offers superb sensitivity, selectivity and full audio. Coverage from 100 through 30000 kHz provides solid coverage of longwave, medium wave and shortwave in the AM mode (no S.S.B.). This makes it an ideal broadcast receiver for the desk or bed-stand. Tuning is a snap via the keypad, manual tuning knob, Up-Down buttons or 32 programmable memories. The huge LED display provides accurate frequency readout to 1 kHz. Antenna input is via a 50 ohm terminal or SO-239 jack. A 1/8" mini jack is provided for use with earplug or headphones (not supplied). Includes AC wall adapter.
 Regular Price \$249.95 Sale \$199.00 (+\$7 UPS)

The advanced Drake SW-2 features S.S.B. reception, Synchronous Detection, 100 memories and optional remote. Only \$489.95 (+\$7 UPS)

Universal Radio

6830 Americana Pkwy.
 Reynoldsburg, OH 43068
 ♦ Orders: 800 431-3939
 ♦ Info: 614 866-4267
 ♦ FAX: 614 866-2339
www.universal-radio.com
 Quality Communications Equipment Since 1942

BIOLOGICAL HAMMING®

Bio-hams® - Study the chemistry of human aging. Do the planets gravitationally affect cellular processes on Earth? Electronics and plant growth - greater yields from audio frequency fields in irrigation lines?

Create new experiments - contact Edward Vandergrift at 1-800-THEORY 5 or 11759 San Vicente BLVD., Los Angeles, CA 90049.

CIRCLE 355 ON READER SERVICE CARD

Radio Bookshop

Phone 800-274-7373 or 603-924-0058, FAX 603-924-8613, or see order form on page 88 for ordering information.

FREE

Wayne has a whole bunch of booklets you'll enjoy—like How to Make Money, The Bioelectrifier, WWII Submarine, Caribbean, and other Adventures, Editorial Collections, Instant Morse Code Course for the truly lazy, Reading Guide, Cold Fusion, and etc. Ask for FREE 16p list of WAYNE'S STUFF.

EVERY ISSUE OF **73** Amateur Radio Today on Microfiche!

The entire run of **73** from October 1960 through last year is now available. Over 800 fiche!

You can have access to the treasures of **73** without several hundred pounds of bulky back issues. Our 24x fiche have 98 pages each and will fit in a card file on your desk.

We offer a battery operated hand held viewer for \$75, and a desk model for \$260. Libraries have these readers.

The collection of microfiche, is available as an entire set, (no partial sets) for \$325, plus \$5 shipping (USA). Annual updates available for \$10. Satisfaction guaranteed or money back!



BUCKMASTER



6196 Jefferson Highway
Mineral, Virginia 23117 USA
540:894-5777•800:282-5628
Fax 540:894-9141
e-mail: info@buck.com

CIRCLE 168 ON READER SERVICE CARD

Parts List and Presets for Fig. 3(b)

For the 36 presets plus the variable, add these parts to Fig. 3:

Part	Description	Notes
Switch	2P6T	RS# 275-1386
Switches (3)	SP12T	RS# 275-1385
LEDs (4)	Your choice	
Resistors (4)	1/4 W 330 ohms	
Pot	250 k	Circuit Specialists [1-(800)-528-1417] 31VA503
Trimmers (20)	10 k	32AA401
Trimmers (16)	50 k	32AA405
Resistors (36)	Fixed values per presets below	
Presets		
#	Pot	Fixed
1	50 k	180 k
2	50 k	180 k
3	50 k	180 k
4	50 k	120 k
5	50 k	100 k
6	50 k	100 k
7	50 k	100 k
8	50 k	100 k
9	50 k	100 k
10	10 k	100 k
11	50 k	100 k
12	50 k	82 k
Presets		
#	Pot	Fixed
13	50 k	68 k
14	50 k	68 k
15	50 k	68 k
16	50 k	68 k
17	50 k	68 k
18	10 k	68 k
19	10 k	68 k
20	10 k	68 k
21	10 k	68 k
22	10 k	68 k
23	10 k	56 k
24	10 k	56 k
Presets		
#	Pot	Fixed
25	10 k	56 k
26	10 k	56 k
27	10 k	51 k
28	10 k	47 k
29	10 k	47 k
30	10 k	39 k
31	10 k	39 k
32	10 k	39 k
33	10 k	39 k
34	10 k	33 k
35	10 k	33 k
36	10 k	33 k

Table 3. Parts list and presets for Fig. 3(b). LEDs mount on the front panel next to the preset switch, and next to the variable control. They will give a dim but visible reminder of which control you selected. Fixed resistors varied from 180 k–33 k, depending upon the size of the trimmer and the speed. The slowest speed used 180 k fixed plus 50 k trimmer. The fastest speed used 33 k fixed plus 10 k trimmer. 120 beats/minute used 68 k plus 10 k. To make this economically practical, you will have to get the trimmer pots from someone who sells them for 20–30 cents each. One source is listed. Of course, equivalent parts will work. The use of a frequency counter will greatly expedite setting up the trimmers for this version of the metronome. See Table 5 (in Part 2). The smaller the trimmer compared with the fixed resistor, the higher the resolution for adjustment. In other words, the smaller the pot will make it easier to adjust the preset for the desired setting or beats per minute. In some cases, a 25 k pot would have worked here but was not immediately available.

Another quick trip to the test bench showed that the “new and improved” (modified) circuit does indeed have more volume than the bare-bones UJT circuit. It may give a loud enough tick for some musicians, and it is a somewhat simpler

circuit. UJTs don't cost that much if you have to go to the store anyway. Fig. 4 gives the circuit for the amplified UJT metronome, one of several options. We will go over some of those options in the construction section, Part 2.

Millen-Dollar Replacement

Here's a clever and cents-ible way to make your own quick disconnect.

Ronald Lumachi W2CQM
73 Bay 26th Street
Brooklyn NY 11214-3905

Linear amplifier builders are finding it increasingly difficult to locate sources even for run-of-the-mill project components. And it's literally impossible to find, at any price, those dead-special items essential to completing that new home-brew amp supply!

For example, try ferreting out a bank of high capacitance/voltage filter caps for the plate voltage supply, a heavy-duty bandswitch, or a rotary inductor

that will handle the rigors of full legal power. I can tell you from personal experience that it will take a lot of hamfest legwork to even *begin* to make a dent in your parts list.

High up on this roster of necessities, and perhaps even more elusive, is the James Millen combination HV terminal/through-bushing #37001 (Photo A). That rascal was specifically designed to conveniently disconnect power via a high voltage cable from the remote power supply to the outboard RF deck.

Some builders (including myself) have reluctantly substituted a variety of (expedient) methods to transfer power to the high voltage circuits via a quick disconnect chassis feed-through system. The most common scheme, in the absence of an appropriate component, used an SO-239/PL-259 combination with some essential safety-oriented modifications. Obviously, in this instance, only the center conductor was wired into the circuit. The mods included insulating the SO-239 socket assembly from the chassis ground with a piece of Plexiglas™ and encasing the metal outer covering of the plug with several turns of electrical tape or a length of shrink tubing.

Admittedly this system has many *caveats*, but in the absence of locating a Millen component, the substitute scheme worked reasonably well over the years. However, I readily admit that I was never completely comfortable with this arrangement. The reason became abundantly clear when I inadvertently connected the high-voltage PL-259 to the coax cable input of the linear and fired up the power supply. At that instant I realized it was time for a change!

As a result of that *jolting* experience, a workable solution mystically occurred to me. What I couldn't figure out was why I didn't think of it sooner. In any event, if you had a similar problem, consider the following mini-project. It's an inexpensive, non-bulky, alternate solution to the routing of high voltages around and into the RF deck. It transforms a readily available fuse-holder into a safe and dependable substitute disconnect assembly for addressing the HV uncoupling function.

Finding a Millen substitute wasn't easy!

The least complicated solution to getting high voltage from the remote power supply to the RF deck is simply



Photo A. The James Millen #37001 HV terminal/through-bushing has been a handy workhorse for many years.

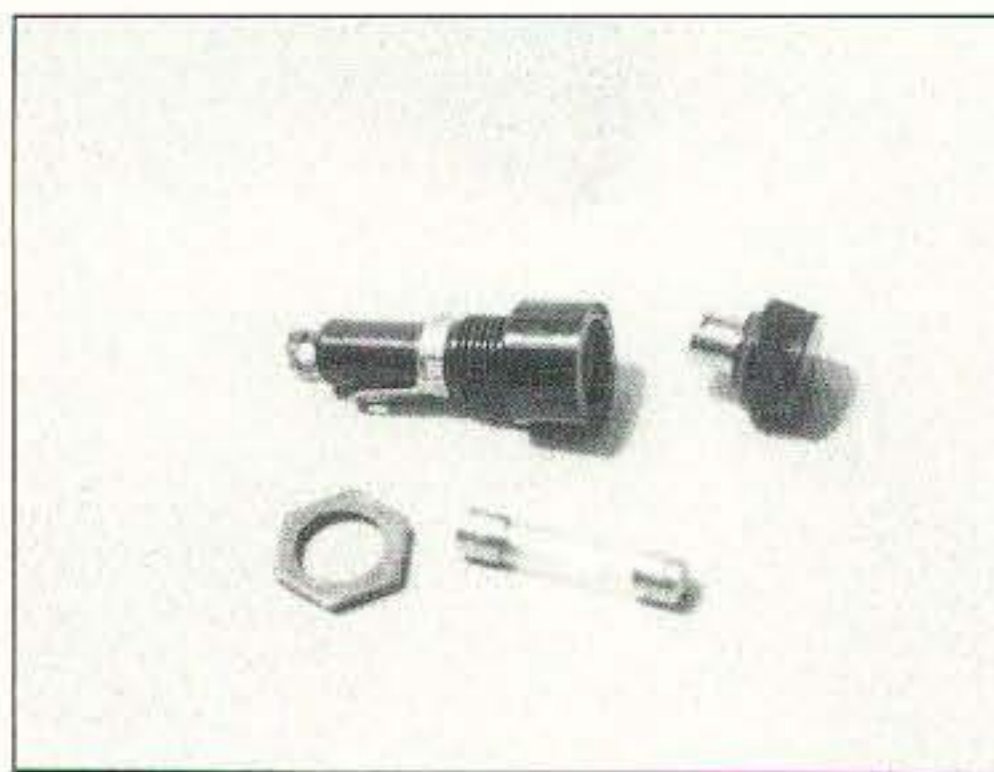

Photo B. The component parts of the standard fuseholder. Make certain that the cap fits the base with a bayonet twist and that the fuse is the correct length and amperage.

to solder the center conductor of an HV cable from the DC output on the supply directly to the base of the HV parasitic choke. Wire in a doorknob bypass to ground at that point, and you're in business.

The case would be closed on this simple problem except that on each occasion involving disconnecting the deck from the supply, the process would involve snipping the lead. When the deck and supply were reconnected after servicing, resoldering would be required. It's a foolproof system, but a tedious chore. It's obvious that the use of a quick disconnect connector would be a welcomed convenience. Cabling up coax, antenna relays, and AGC to the deck routinely employs a variety of connectors, so why not incorporate a similar system for the high voltage hookup as well?

The basic concept underlying this project involves a simple modification to the bayonet-type, molded plastic garden variety fuseholder. These units are available from hamfest vendors, retail suppliers, and a large number of catalog sources for about \$0.75-\$1.50

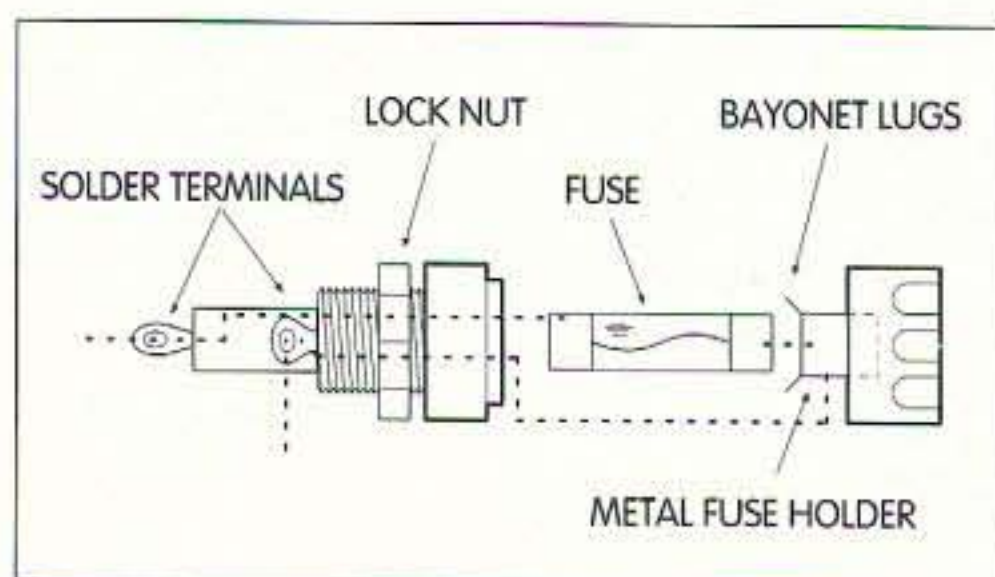

Fig. 1. The unmodified fuse assembly. The electrical path is from lug to lug via the internal fuse (dotted lines).

(**Photo B**). Although it took some time to realize that the standard two-piece fuseholder could be easily and safely adapted to accomplish this task, subsequent experiences with several installations utilizing this device have proven unquestionably that the modified fuseholder serves quite effectively and at a reasonable cost.

Where to begin?

Locate a standard chassis-mount fuseholder in an old piece of gear, your junk box inventory, or at Radio Shack™ (#270-367). Make certain that the removable portion is the type that secures itself to the base with a half (bayonet) twist and that the spring providing tension to the assembly is located in the base rather than in the removable cap. Screw-in types are not feasible, since they tend to twist the HV lead when being installed. Understandably, it's best to get the HV lead securely cabled up with the least amount of manhandling.

At this time, it would be a good idea to purchase a one-amp fast-acting fuse with the correct overall length for the holder. Standard size fuses are approximately one-and-one-quarter inches in length (some are shorter) and are designed specifically for a particular holder. This fuse will be series-installed in the plate HV line later to provide continuity through the holder. In addition, its use provides a measure of protection from parasitic spikes and transients (glitches) that could possibly require tube replacement as a result of an irreparable grid-to-filament short.

To begin, select a drill bit that approximates the diameter of the inner conductor of the HV wire. In the absence of a micrometer, it's perfectly OK to eyeball the size and drill a test hole to ensure that the wire will pass through. You'll find the size to be about one-eighth of an inch in diameter, depending on the gauge of HV wire you're using.

Drill a pilot hole completely through the center of the plastic cap as well as through the metal on the interior of the cap that accepts the conducting end of the fuse. As you're drilling, pay particular attention to the thickness of the

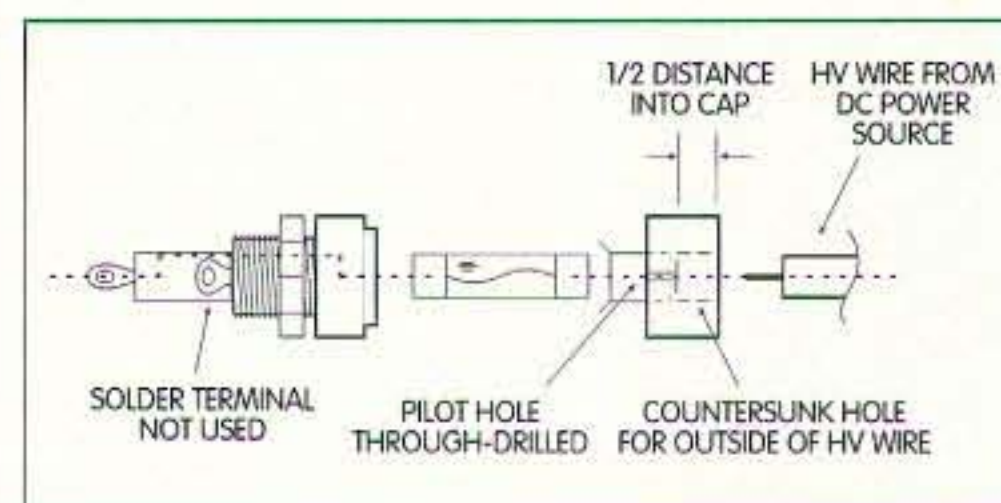

Fig. 2. The modified cap. Note the altered electrical path through the cap (dotted lines). Continuity is achieved through the fuse. Also note the small pilot hole drilled for the HV center conductor and the countersunk hole to accommodate the HV wire. Drill the larger hole to one-half the depth of the cap.

plastic cap. This measurement is important for the next step. In the event you find a small coil spring assembly providing tension within the cap, simply remove it and reposition it in the base of the fuseholder.

For the second drilling step, measure the outside diameter of the HV wire (you'll need a length sufficiently long to reach the DC source) and select a drill bit that approximates that size. A slightly smaller hole is OK. Avoid making the opening overly large, since a snug fit is preferable for a better mechanical bond (discussed later).

Using the smaller hole as the pilot, carefully countersink the second hole approximately half the distance into the plastic cap. You should have a sense of the correct depth of the plastic from the previous step. Remember, you don't have to go too deep, so complete this step with care. Using a sharp knife or razor, remove a sufficient length of outer HV wire protective covering so that the center conductor will reach approximately one-eighth-inch to three-sixteenths-inch beyond the inner cavity of the cap when the outer protective covering rests firmly in the base of the larger countersunk hole. Snip off any excess wire if it extends beyond the length required. Remove some insulation if the inner conductor comes up too short.

At this time, unravel the strands of the twisted center conductor so that the wire is straight along its length. Before moving along to the next step in the process, burnish the metal on the inside/top of the cap to prepare that area for a good solder bond.



Photo C. After drilling the pilot hole for the center conductor, drill a hole in the cap equal in size to the diameter of the outer core of the HV wire insulator. Solder the center conductor of the HV wire to the interior of the cap, and then apply epoxy to the outer sheathing of the HV wire to ensure a good bond to the cap.

This can be accomplished in several ways. Since the opening is rather small, use a power drill and a drill bit to break the metal glaze. You can also use a small piece of emery cloth. Roll it tightly and work it into the opening. A Dremel™ tool equipped with an emery wheel is a real time-saver if one is handy. Burnish the area thoroughly until you're certain that the solder will adhere solidly. While you're at it, give the top of the plastic cap a quick scuffing with a piece of sandpaper positioned on a flat surface. You'll need a good surface for bonding the wire to the cap with some epoxy used in a later step.

Before proceeding further, make certain that you have a preheated sol-

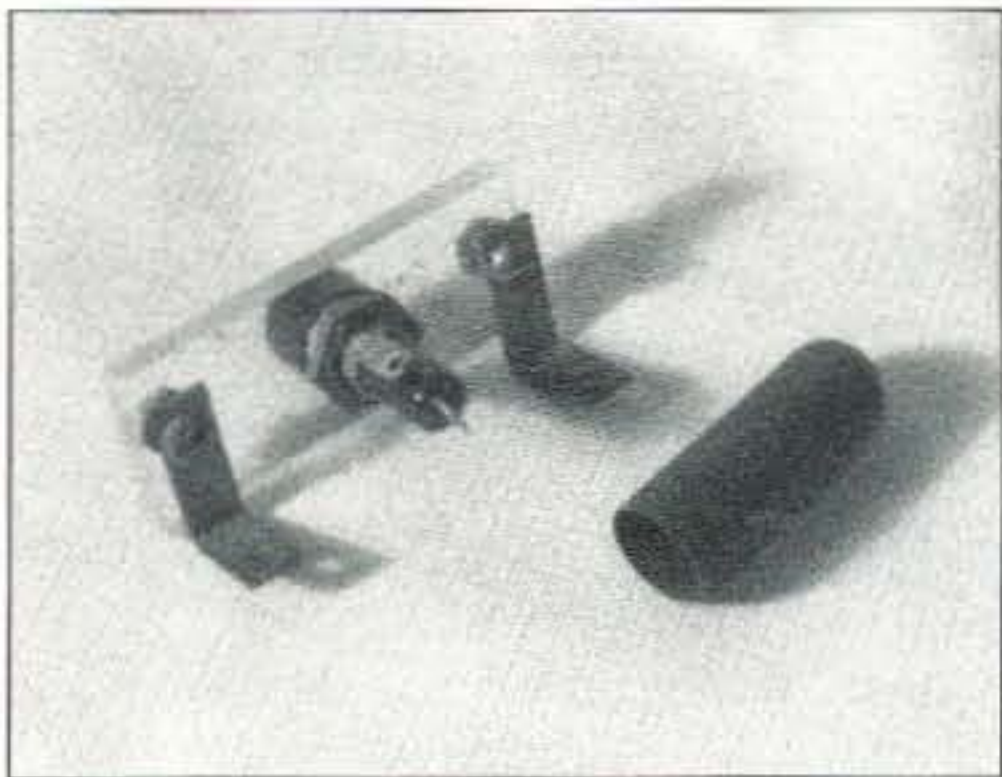

Photo D. A view of the Plexiglas insulator and right angle chassis mounting bracket. The lug visible on the barrel is live but will not be used. Use a length of shrink tubing or several layers of electrical tape over the exposed portion of the barrel lug to protect yourself against shock.

dering iron with a narrow tip that reaches inside and to the bottom of the cap. Circuit board irons work particularly well here. Flux the inside of the cap as well as the center conductor.

Prepare a small amount of two-part epoxy at this time. Coat the outside of the HV wire (to the extent it will be seated into the drilled opening of the cap) as well as the side walls of the cavity in the cap. Use a toothpick to spread the epoxy evenly (**Photo C**). Make an effort to keep the epoxy bonding material out of the small pilot hole. If any material accidentally gets in there, ream it clean with the unfluted end of the drill bit. Don't tin either the wire or the cap's interior prior to the final step in the installation process. Slip the wire into the pilot hole and push the HV cable firmly down to the base of the countersunk hole.

Check to see that the center conductor extends that short distance into the metal cap. Use a narrow, blunted object to mushroom the short length of wire projecting into the base. The broad end of a good-sized finishing nail or even the pencil-tipped soldering iron works well here. Spread the wire evenly around its center in a sunburst fashion rather than bunching it in one area.

With the cap held vertically (fuse end up), drop a one-quarter-inch length of solder into the base on the fluxed area. Insert the tip of the iron into the cavity of the cap (against the metal and mushroomed wire) and heat sufficiently to allow the solder to flow. Try not to build up too much solder height, because the interior space provided within the holder will be lessened when the fuse is installed. If, after soldering, an attempt fails to get the assembly to lock up in place with the fuse installed, carefully use a one-quarter-inch drill to reduce the height of the solder dome. Make frequent checks until the cap locks together solidly under spring tension.

Use your VOM at this time to check for continuity from the far end of the HV wire (through the fuseholder) to the solder tab at the far end of the fuse. When you get it to fit snugly and the installed one-amp fuse completes the

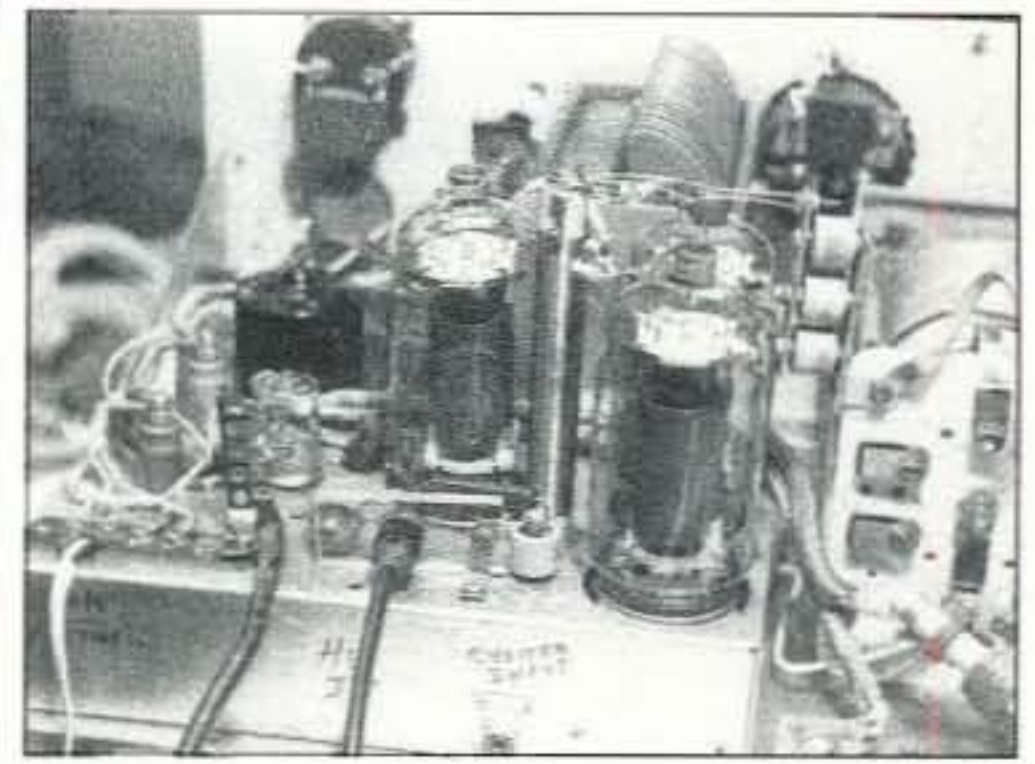

Photo E. The home-brew linear amplifier with the fuse disconnect mounted on the chassis near the HV plate choke. It's a good idea to secure this lead with a plastic-type strain insulator. The small through-chassis hole to the immediate left of the fuse body will be used to bolt a strain relief clamp in place.

series circuit, the mod is just about completed.

Allow the epoxy to set. Wrap the fuse body with several turns of electrical tape since the unused barrel lug connecting point, although still very much in the circuit, will no longer be

Continued on page 80

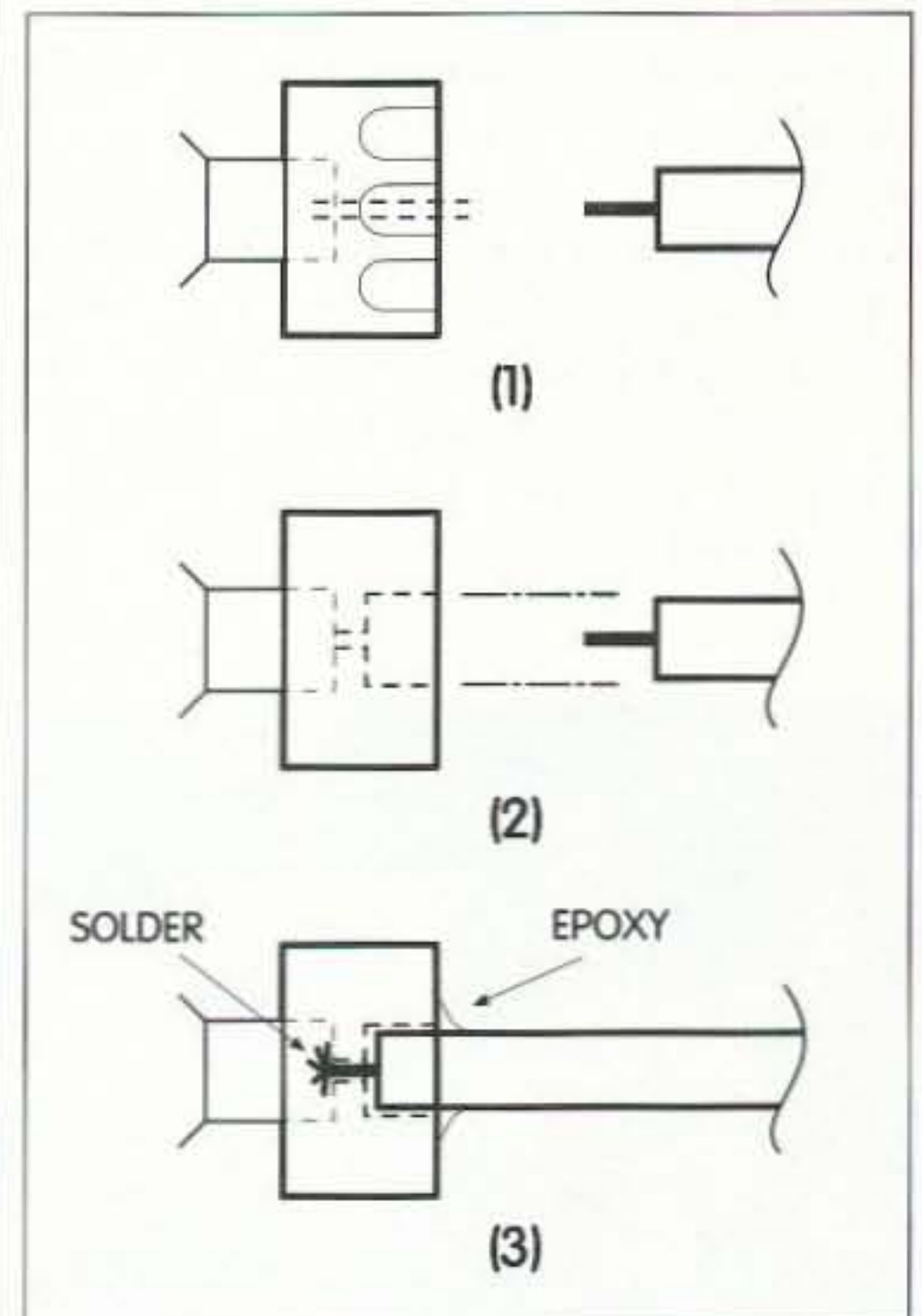

Fig. 3. Cap preparation. Step 1: Drill pilot hole through center of cap and interior fuseholder. Step 2: Countersink the hole (slightly undersized) to accommodate HV wire. Step 3: Scuff top end of fuseholder for better bonding; seat HV wire into base and epoxy; mushroom and solder center HV lead to metal fuse insert.

ABOVE & BEYOND

VHF and Above Operation

C. L. Houghton WB6IGP
San Diego Microwave Group
6345 Badger Lake Ave.
San Diego CA 92119
E-mail: [clhough@pacbell.net]

Oscillator considerations for 1296 MHz

This month, I want to cover several oscillators that can be used for 1296 MHz. Noting that there are many different systems that can be utilized, each with its own particular attributes and liabilities, I will cover them in a discussion format in order to better inform you on their differences.

What are the different types of oscillators that can be found for use in this endeavor? First is the crystal oscillator/multiplier type. Second, there is the phase-locked "brick" type of local oscillator. Third, there is the synthesizer-controlled local oscillator. I have used each of these at different times and can recommend all three systems for use in construction of a converter as long as you realize their associated quirks.

Let's take them on one at a time. In each description each oscillator will generate 1152 MHz, the frequency required for mixing 1296 MHz down to

144 MHz. The two-meter multimode radio will serve as a base intermediate frequency (IF) for both receive and transmit, with appropriate power reduction circuitry.

The crystal oscillator/multiplier system is easy to construct and available from several kit suppliers. It also can be home-constructed from references in the *ARRL Handbook*. Its primary starting point is a crystal-controlled oscillator normally in the 96 MHz range and associated multipliers to multiply the 96 MHz crystal frequency to the 1152 MHz required for injection to the mixer. (1296 MHz minus 1152 MHz equals 144 MHz for tuning 1296 to 1300 MHz on a two-meter multimode radio.)

Advantages of the crystal oscillator include easy parts gathering and low cost, as all materials can either be put together from a supplier's kit or home-assembled. New cost is in the \$50 range. Relatively easy construction, with little test equipment required to assemble.

The oscillator produces a very clean output signal, with phase noise down nearly 90 to 100 dB. Liabilities include frequency instability or decreased accuracy in knowing exactly where in frequency you are operating at. Some improvements to this oscillator can be implemented, such as temperature-controlling the 96 MHz crystal. The real problem here is the stability of the local oscillator.

The phase-locked "brick" type of local oscillator is an offshoot of the crystal multiplier system, in that it generates the 1 GHz sum frequency with a high-power oscillator that is under phase-locked control of a similar 96 MHz crystal that is oven-controlled for improved stability. This oscillator depends on the adjustment of the 96 MHz crystal and the matching adjustment of the high-power oscillator to the 12th harmonic of the crystal. When the power oscillator is adjusted very near the 12th harmonic, the sampling circuits produce a phase lock of the high-power oscillator to the controlling crystal.

The sampling circuit receives the 96 MHz crystal and all its harmonics. It also receives a sample of the high-power oscillator. When each is very near frequency, the high-power oscillator is under control of a video op amp that will vary voltage to a varactor in the high-power oscillator compartment which will cause this oscillator to track the 96 MHz crystal and its harmonics. Retained is the very high degree of spectral purity (very clean output) of the basic crystal oscillator. It has many improvements to help stabilize the crystal frequency but still drifts to a smaller degree of less than 1 kHz under best conditions.

Difficulties include the relative expense of crystals (\$25). Also, this is a surplus oscillator so other than building a single unit or two, parts might be a problem for a club project. Power requirements can be a problem, as different models

require 20 volts normally positive ground although some models are out there which are 20 volts negative ground. If you can find this unit at reasonable cost in surplus use it. It will work quite well for you.

The bricks to obtain are the ones that were used for output frequencies of 5 to 6 GHz. The reason is that the multiplication scheme used was a "times-five." By dividing the output frequency of a 5 to 6 GHz brick by 5, you arrive at the high power output frequency which is in the 1 GHz to 1.3 GHz range. If you divide 5760 MHz by 5 you arrive at 1152 MHz. In the original brick, 5760 could be an obtained frequency but by removing the x5 multiplier and putting a small coax probe in the cavity you now obtain the lower frequency of 1152 MHz. The crystal required is a divide-by-60 or the multiplier (x5) times the harmonic used (12th) or $5 \times 12 = 60$.

Bricks that were made in the 8 to 12 GHz output range use a quite similar scheme. Different multiplication is involved, which produces a higher local oscillator frequency in the high-power oscillator. These bricks use 1.7 GHz to 2.0 GHz as the high-power oscillator and use the 6th harmonic of the high-power oscillator and the 17th harmonic of the crystal, or 6 times 17 for a total multiplication of 102. There are other possibilities including 6x18 and 6x19 that could phase-lock and produce erroneous frequencies.

I personally have several systems in operation using the brick-type oscillators and they work well. They are somewhat drifty as to frequency. If you want accuracy, you must maintain the oscillator every day to adjust it to proper frequency after a suitable warm-up period. This warm-up time can be several hours before stability is reasonable. Bringing the oscillator into other environments can affect the final frequency and its accuracy. Even with that it still produces a very dependable



Photo A. Brick-type oscillator from Frequency West. Consists of a 100 MHz (approx.) crystal controlling a high-power oscillator at times 12 to phase-lock the unit. It then multiplies in a varactor to higher microwave frequency. (Multiplier not used when oscillator set up for 1152 MHz and 1296 MHz use.)

oscillator and functions well even with its frequency variance.

The phase-locked synthesizer

The synthesizer type can be costly to reproduce/build and its parts hard to locate. Additionally, if you have to build one it's quite a job, and not a small undertaking. Not wishing to discourage you, I can tell you that the situation is not all that bleak. Our microwave group was able to work out conversions to commercially-built synthesizers that adapted them to amateur configurations. Then the only other problem was to obtain a reasonable quantity of them to allow usage by all those who wanted to give a synthesizer a try. I can't say this enough: The main trick in trying to be helpful is for me not to describe a piece of "unobtainium" or an item not found in quantity. Something must be reproducible or obtainable if it is to be of any use at all to you.

Well, then, what are the benefits of a synthesizer or, more correctly, a surplus commercially-made synthesizer? Like the brick, you start out with a commercially-manufactured piece of equipment that was constructed to very high quality standards. Another—and the main—advantage of the synthesizer is that its frequency output is controlled by a very high accuracy 10 MHz frequency standard. This controls the frequency accuracy of the microwave output to a high degree. A normal accuracy to expect at 1200 MHz is less than 100 hertz. Another benefit is that the synthesizer runs on 12 volts DC and sports onboard voltage regulators. Not a big point, but a plus.

The liabilities of the synthesizer lie in one single point: phase noise. Produced in the synthesizer process, this phase noise is a byproduct that can be minimized but not eliminated. It causes trouble in both receive and transmit by not being a very pure note or frequency source (unlike the products of

the crystal oscillator or brick-type methods of local oscillator frequency generation, which are very pure with no extraneous side frequency products produced by the frequency generation process). The synthesizer has extraneous side frequency products due to its method of generation—we call this "phase noise." These byproducts can be suppressed. At present we have been successful in reducing them some 35 dB lower than the main carrier frequency output.

What does this phase noise trouble do to the performance of a converter you might use the synthesizer in? Well, it's like receiving a signal with a receiver with a few "birdies," especially when you get a congested adjacent strong near-frequency signal at the same time you are in communication with someone on a nearby frequency. It doesn't cause any discomfort, but is somewhat distracting and not a pure signal. This effect is not noticeable when there is no other close strong signal present when you are communicating with one station.

One of the greatest benefits that I believe outweighs any possible problem with the phase noise is the frequency synthesizer's frequency accuracy. In many systems these days, the average frequency accuracy is phenomenal. The reason for this is that the synthesizer is controlled by a high-accuracy 10 MHz reference oscillator to which all synthesized frequencies generated are referenced. We have used a 10 MHz reference that is a TCXO (temperature-compensated crystal oscillator) accurate to 1 Hz at 10 MHz to achieve this stability.

Reference this all to 1152 MHz, and the accuracy of the output of the synthesizer is less than 100 Hz error no matter what the turn-on time or the temperature. I am not talking icy to desert-hot, but various changes in ambient temperature will not affect the stability to any great degree. In actual operation, you

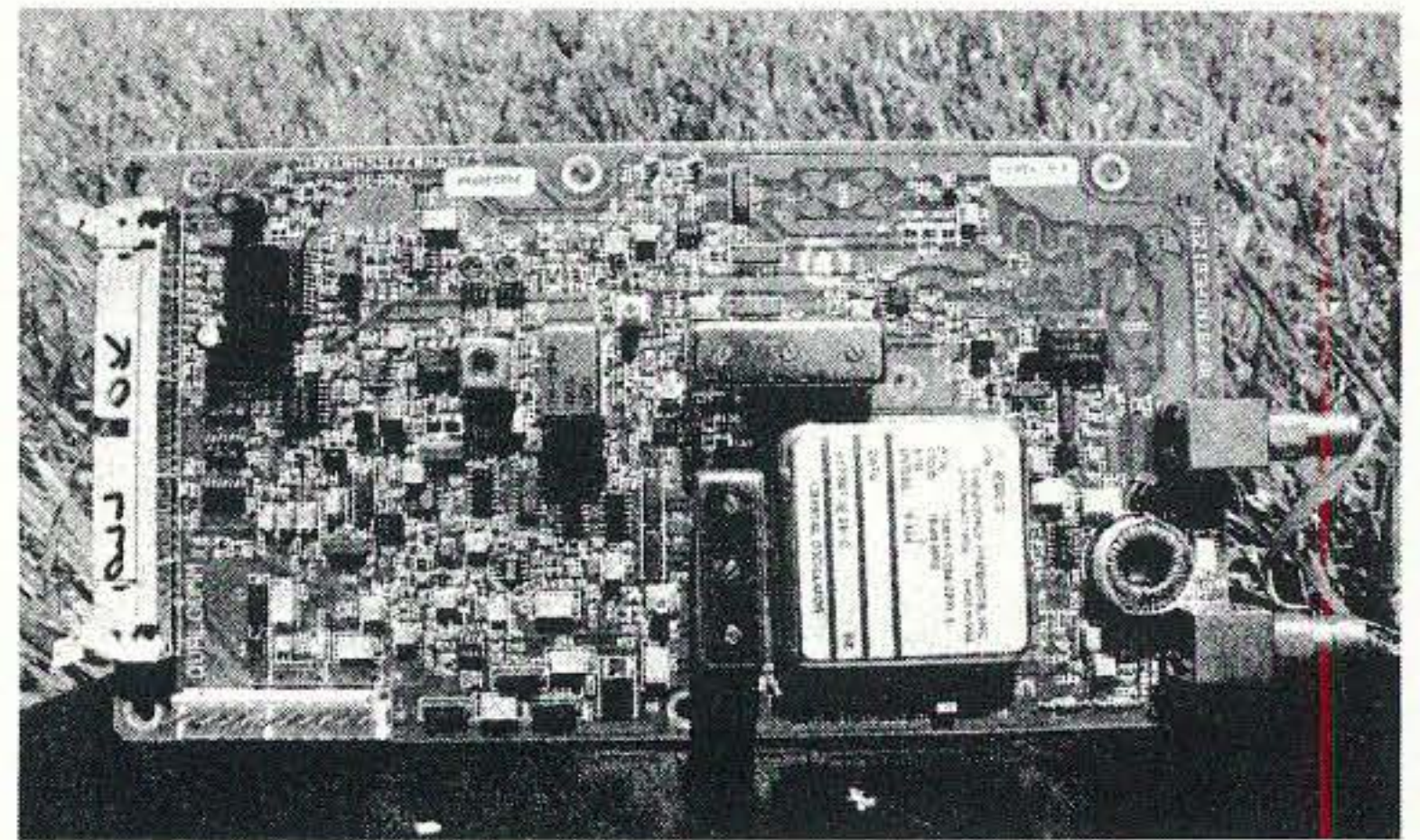

Photo B. Qualcomm PC board showing all circuitry on board (much more than required in our conversion). We are using the 3036 synthesizer and its VCO, which runs in the 1000 MHz range.

can consider that from cold start operation at turn-on you can be accurate to a precise frequency and be able to find stations by just a small adjustment of the SSB clarifier RIT control. Most of the time, under various conditions, a receive signal can be produced when

both the transmitting and receive station are using similar synthesizers and accurate TCXO oscillators.

In this case, finding a signal without hunting up and down the band is possible. What we

Continued on page 52

MultiMode

TNC **BayPac** TM **NEW**

- SITOR A/B
- ARQ/FEC
- BAUDOT
- PACKET
- NAVTEX
- FAX 480
- AMTOR
- WEFAX
- SYNOPSIS
- ASCII
- RTTY
- SSTV
- CW
- More...

BP-2 Packet Only \$49.95
BP-2M MultiMode \$69.95
+ \$5 Shipping & Handling

The best little packet modem just got better! Building on the tradition of the BP-1 Packet Modem, we are very proud to announce the BP-2 and BP-2M. The BP-2 is a new and improved version of our famous BP-1, while the BP-2M expands your horizons even further with MultiMode operation! So, whether you have been waiting to automate your CW, checkout AMTOR or just copy Weather Fax - Now is the time for you to jump in and join in all the fun!

Tigertronics INCORPORATED **Call Today! 1-800-8BAYPAC**
800-822-9722 (541) 474-6700 Fax 474-6703
World Wide Web: <http://www.tigertronics.com>

VISA
MasterCard

Tigertronics, Inc. 400 Daily Ln. P.O. Box 5210 Grants Pass, OR 97527
CIRCLE 269 ON READER SERVICE CARD

ASK KABOOM

Your Tech Answer Man

Michael J. Geier KB1UM
c/o 73 Magazine
70 Route 202 North
Peterborough NH 03458

Trends

Last time, I discussed some ideas for new modes of communication. Given that this is 1998, they centered on digital technology. Like it or not, those darned bits are here to stay! They require new ways of looking at things, but they do have many advantages. Are there disadvantages to digital technology? Yes, there are. The biggest is probably complexity. Although a few chips on a board may not look like much, the action going on in those chips, and the way they work with each other, can be enormously complicated. Why should we care? Well, things we used to take for granted, such as the ability to tweak our gear for some desired performance

characteristic, may no longer be possible.

Here's a good example: Back in the 1980s, I got my first 8 mm camcorder. I'd had over-the-shoulder video gear for years, but the small size of the camcorder was a tremendous improvement. The machine made gorgeous pictures, with excellent color. Alas, it didn't perform its edits properly (there were flashes between scenes), so I sent it back for an exchange. The replacement camera edited flawlessly! This one, though, made very greenish color. Sigh. Back it went. The third camera made even worse color. I gave up. Being the inveterate tweaker that I am, though, I couldn't live with that lousy color, especially after having seen from the first

unit that nearly perfect color was attainable. Out came the old screwdriver, and I dove in.

In those days, the camera sections of camcorders had anywhere from 10 to 30 adjustments! We take cheap, high-quality color TV cameras for granted now, but there's nothing simple about them. (In fact, the cost of the camera section is what held up the introduction of the camcorder for years, not the tape transport, which is basically a shrunken VCR.) Through some careful measurements and a few "try it and see" tweaks, I was able to deduce which control did what. There were 12 of them, as I recall. It took some time, but I finally diddle that camera into the kind of color rendition it

"The board full of mixers, delay lines and other analog processing stuff has been replaced by a couple of tiny chips."

raw video signal coming from the image sensor, digitized it and then did all the various signal corrections and other processing in the digital domain. The "alignment" consisted of connecting a special programming unit (only available to the manufacturer and some of its factory-authorized service centers) and changing the settings in software in order to obtain the desired performance! Thus, I was completely locked out of making any changes to the camera's behavior. Sure, I could have taken it into a factory-authorized service facility, told them what I wanted, paid lots of money (if they didn't just laugh me out the door) and hoped they got the thing close to what I wanted. I chose instead to just live with it the way it was. Is there an upside to this loss of end-user control? Yes, there is. That camera's adjustments have never drifted one iota, and its performance is exactly the same as it was the day I got it.

Moreover, the performance variation from unit to unit of something built this way is very low; if you like your friend's machine, chances are the one you buy will work pretty much exactly the same. My experience with the three older, analog-based cameras certainly hadn't shown that to be true previously.

This trend toward permanently-adjusted equipment isn't going to go away. Ham gear, too, is going more and more digital, and I expect the pace of that conversion to accelerate dramatically in the next few years as faster and faster DSP (digital signal processing) chips work their way up from the audio chain right to the first mixer of our receivers. Along with the shift to totally digital processing will come the lack of adjustments.

It's happening now. Just a couple of years ago, DSPs were too slow for anything but audio. Then, suddenly, we began seeing IF filtering being done via DSP in HF rigs. The rumors are already floating around that RF-

Continued on page 53

ABOVE & BEYOND

continued from page 51

are able to do is announce what frequency we will transmit on and have the receiving station find the received signal with minimal tuning by just adjusting the RIT control. Most signals have been within the audio passband of the mode used, be it SSB (2.1 kHz) or narrowband FM (5 kHz) bandwidth.

You must know by now that I favor the cause of the synthesizer, with all its benefits and liabilities. The main reason is the availability not of a few units but rather of many units, enabling amateurs to more easily acquire a simple, low cost platform on which to construct a transceiver/converter for the higher microwave bands.

If you, on the other hand, can run across other types of

oscillators, I do not want to slight them. Use any piece of material you can obtain for a transceiver. This article was written with the goal of giving you information on what the benefits of different types of systems can be and to guide you into making a choice. Hopefully it will let you avoid a piece of equipment that will not function and is priced too dearly.

Next month, I will describe in greater detail the synthesizer we have adapted for use. This synthesizer and its board that we used for the 1296 MHz local oscillator is a different board from the units previously covered for 10 GHz use. While the basic Qualcomm 3036 synthesizer chip is used in both units, the board layout and conversion information are quite different. 73, Chuck. 73

should have had to begin with, and I enjoyed its use for several years, until something smaller and nicer came out, at which time I replaced it.

The new camera made color nearly as good as the old tweaked one had, but not quite. It was certainly good enough, but I just had to see if I could make it ideal. Not this time! There were no color adjustments in that camera at all! Could it really be that manufacturing tolerances had become so precise that a color television camera didn't require any alignment whatsoever? Of course not! So, where the heck were the controls?

The new way

This new camera, which is now about six years old and still going strong, used digital signal processing for the camera section. That means that it took the

Jack Heller KB7NO
712 Highland Street
Carson City NV 89703
[jheller@sierra.net]

Serial modem, soundcard, or plain old TNC?

You, the readers of this column, are very supportive of my endeavors, judging by the mail. You have read of my experiences with packet modems, TNCs, and even SSTV on the soundcard. It is possible to operate packet on any of these devices and it is being done.

To choose one method over another always calls to question the balance between cost and difficulty. This can be hard to

grasp until you experiment. From the outside, it always looks as if someone has something working, and that you should be able to duplicate that result. Today, we look at some of the stumbling blocks that test our patience.

Search for components

Sometimes, when you have fought the good fight and come up just outside the winner's circle, you find something that makes the struggle seem worthwhile. Just today, I ran across a

packet bulletin from another ham looking for the TCM3105 that is so essential to building a BayCom look-alike. I know the story on them and was glad to offer condolences to someone else who was tilting at windmills.

As the story unfolds, those chips are out of production. I saw some listed for \$11 on a Web site. I called the company and could see that I was mystifying them. That was as close as I got. In Europe (where all this 1200b VHF serial modem fun began), they claim another chip, the AM7910 or AM7911, will interchange, but these chips do not willingly cross the ocean so they are not listed as available here.

Help from abroad

Some of this information was learned by chasing up blind alleys and hearing from a

few helpful readers in Europe. Two hams are quite encouraging of our projects. Paulo CT1DTA has successfully implemented a serial modem and the PCFlexnet software, plus he has had the same software up and running with his soundcard. He says his soundcard project runs a little slow, but that with my faster computer, there should be no problem.

Back to the packet modem. One thing at a time. My other cheerleader on that side of the water is George SV2AGW, who writes ham programs and puts them up on his Web site [www.forthnet.gr/sv2agw/]
—free for the taking. He was able to find the cross-reference on the modem chip mentioned above.

Another alert reader, Dale (he forgot to include his call, and there are four Dales with the same last name in the QRZ

Ask KABOOM

continued from page 52

speed DSPs are on their way. What does that mean for us?

HF goes modern

Imagine an HF rig the size of a small two-meter mobile. Yes, they already have some pretty small ones, but I'm talking half the current size—or even smaller. This wonder radio will have, at most, a couple of tuned circuits in the front end. It might not even have those! Gone will be the boards full of coils and filters. The incoming signals will be digitized, and virtually everything else, from selectivity to SSB detection and opposite sideband rejection, will be done in the digital domain. Want independent high and low slope tuning? No problem; it's just some numbers fed to a DSP chip! (And the shape factor of the filtering will be phenomenally better than what we now get from any combination of ceramic or crystal filters.) Want multiple tracking notch filters?

Again, same thing. How about automatic QRN reduction or a really good noise blanker? A few more lines of code. You get the idea.

The transmitter will be all-digital, too. Actually, some full-sized HF rigs are doing this right now. The incoming audio is digitized, and then it's "mixed" with the bits representing a carrier by doing calculations on the bits. All of the functions of mixers, balanced modulators, speech processors, etc., are done in software. Out the other end of a few chips comes the RF signal, ready for the final amp. And that signal's a darned sight cleaner than what our analog circuits have made all these years.

As hardware gets replaced with firmware (software on a chip), the size, cost, and observable complexity of radio gear will dwindle to the point of absurdity. Chips are small compared to the boards full of coils, caps and amplifier stages they replace. After you make enough of them, they're way cheaper, too. Have you seen how small

the new digital camcorders are? Part of the size reduction is due to the new tiny tape and transport, but an equally important part is because the board full of mixers, delay lines and other analog processing stuff has been replaced by a couple of tiny chips. Right now, digital camcorders are very expensive, but, after a few million have been made, they'll wind up cheaper than current analog formats; there's just less in them.

By the way, I say "observable" complexity because the true complexity will be mind-boggling, and far beyond what a hobbyist can explore on his bench with a basic oscilloscope. Essentially, radios will become dedicated computers, just as CD players are now. As with today's PCs, they'll be extremely consistent from board to board, and will be repaired by simply swapping boards when the old one crashes into the old bit bucket. Is this a bad thing?

I don't think so. True, it does kill some of the magic with which we regard our equipment. Then again, let's not forget that

"Real radios glow in the dark!" In other words, those accustomed to tube equipment felt exactly the same way when transistors swept the old technology into the dustbin of history. Maybe, one of these days, we'll be saying that "Real radios had parts you could change!" Of course, it'll be a while before the final transmitter stages of HF rigs become monolithic, but it'll probably happen. Heck, it's already happened in VHF and UHF FM gear, hasn't it? When's the last time you saw a two-meter mobile rig with a discrete transistor output stage?

I think it's best to enjoy watching the new ways unfold, without worrying too much about the downsides. OK, we won't be able to tweak our rigs. Then again, we probably won't have to. And just think of the complete HF receiver—with all the hot features and performance you expect from today's desktop behemoths—that you'll be able to wear on your wrist! Don't kid yourself... it's coming.

Until next time, 73 de KB1UM. 73

database [www.qrz.com]) advised me that SV2AGW was including a soundcard driver with his packet engine program. He thought that would be wonderful if it was as easy to configure as the rest of his programs.

All soundcards are not created equal

This sounded like something to check into, as the PCFlexnet was going to be intimidating to more than just a few of us. Sure enough, there it was, along with a message from Tom Sailer, the one who engineered the soundboard system for the PCFlexnet group.

This deserves a good look, thought this ham (who was becoming more wary by the minute). The driver is specified to work with soundboards using the "PSA chipset," and, wouldn't you know, that doesn't include SoundBlaster™ (which is pretty much standard in the US and is in this computer in front of me).

I spoke to a few knowledgeable computer folk about this and they had no clue what I was talking about. It is a wonderful feeling to know you are on the cutting edge of something like this. The not-so-good feeling is when you realize it is up to *you* to try it and see if it works, because ... that is what is expected.

I loaded George's AGW Packet Engine after downloading the newest free version. I found that the parameters were still there as I had left them from the last use of the old program. After changing to the soundcard parameters, which didn't appear too difficult, the screen message was to reload the program.

The program came up with George's smiling face watching me from the screen, and it churned for a number of seconds. Then there was a crash! It seemed as though I could hear it. Just my imagination, but there were little windows that kept popping up and it didn't look like I would be able to put the program to bed without turning off the power.

It did finally go to sleep, but a reboot of the program caused the same disaster. It just wasn't going to play the game with some foreign (to it) soundcard. The soundcard parameters can't be changed until after the program comes up, and by then, it's dead in the water. Time to delete the program parameter files, try again, reinstall, etc. You get the picture.

He's working on it

I sent George a message about my experiences with the wrong soundcard. "Ah, Jack," he wrote, with his big smile, "I have been meaning to write a driver for that soundcard, but I am having a problem getting all the information." So you see, George must also exercise patience at his end of the spectrum. I feel a little better.

Interestingly, George added the fact that in Greece, most computers are configured as in the US. Of course, he writes programs for those closest to home. George has added help files where he used to claim they were unnecessary. I was experiencing a decisionmaking time and accessed the help file. I don't know what language they are written in, but my US system recognized that they were not in English, so they won't even display.

With a little help, I am beginning to understand there is a definite difference from here to there. It is almost like two clashing technologies. They both work, and will communicate with each other, but many of the pieces do not interchange.

Back to the modem front lines: George did some legwork for me and found a 1200b VHF modem. I had been lamenting how difficult it is to write about these things when there is nothing in hand to experiment with. That should be in the mail in the next few days.

I make some things too complicated

All the while, there was another irksome problem gnawing at me. Since the old faithful IC-260A

had died, I had not been successful in replacing it with the IC-2AT. The PK232 just didn't want to converse with it.

To tell the truth, the problem was that I tried something I had not attempted before. I had success for years mating the 2AT to the MFJ-1274 and getting the PTT to work with the capacitive-resistance coupling since there isn't a PTT lug on the 2AT.

This time, just to be neat and tidy, I used the inductive approach. The sad thing was that the received audio, having nothing to do with the installed audio transformer, would not get to the TNC. My conclusion was that I needed a separate audio cable to connect to the jack on the PK232, as was the method with the IC-260A. Not in the books.

I put out a distress call on the CompuServe Hamnet and got several answers, but I didn't explain that I was using the inductive method. Three helpful hams came back: John KA6LWC, Don N2IRZ, and Gary (call?). All mentioned only the capacitive-resistance method—and they had used this combination with no auxiliary cable. This sent a message—it is workable.

The next step was to build another of the not-so-tricky but often ugly interfaces to the 2AT with a resistor and a capacitor. The circuit is simple, but I wanted to avoid the wad-of-tape

appearance that so easily accompanies these projects. I have the one made up for the MFJ in a small box. At the time I was experimenting with HF packet and the box included a switch and connectors to two radios.

An idea toward neatness

This time was different, so I found a piece of three-eighths-inch clear plastic tubing. About a two-inch length allowed the AEA-supplied cable to pass through the center, with the capacitor and the resistor on the outside, and a few holes judiciously placed to allow wires to pass through for connection.

It still isn't what I call photogenic—hence, no picture—but it looks like an attempted neatness. For those of you not aware of the problem of interfacing many handhelds to a TNC, the dilemma arises because there is no PTT connector on the radio. Controlling the PTT is a must because there is a lot of automated activity that involves keying the transmitter at just the appropriate time.

Fig. 1 shows the typical wiring necessary to cause the audio input to the radio to energize the PTT circuit. I hear different values being used, but I know these work. One of the contributing hams recommended both sleeves to ground, not just the receive audio shown in the diagram. It seemed redundant but

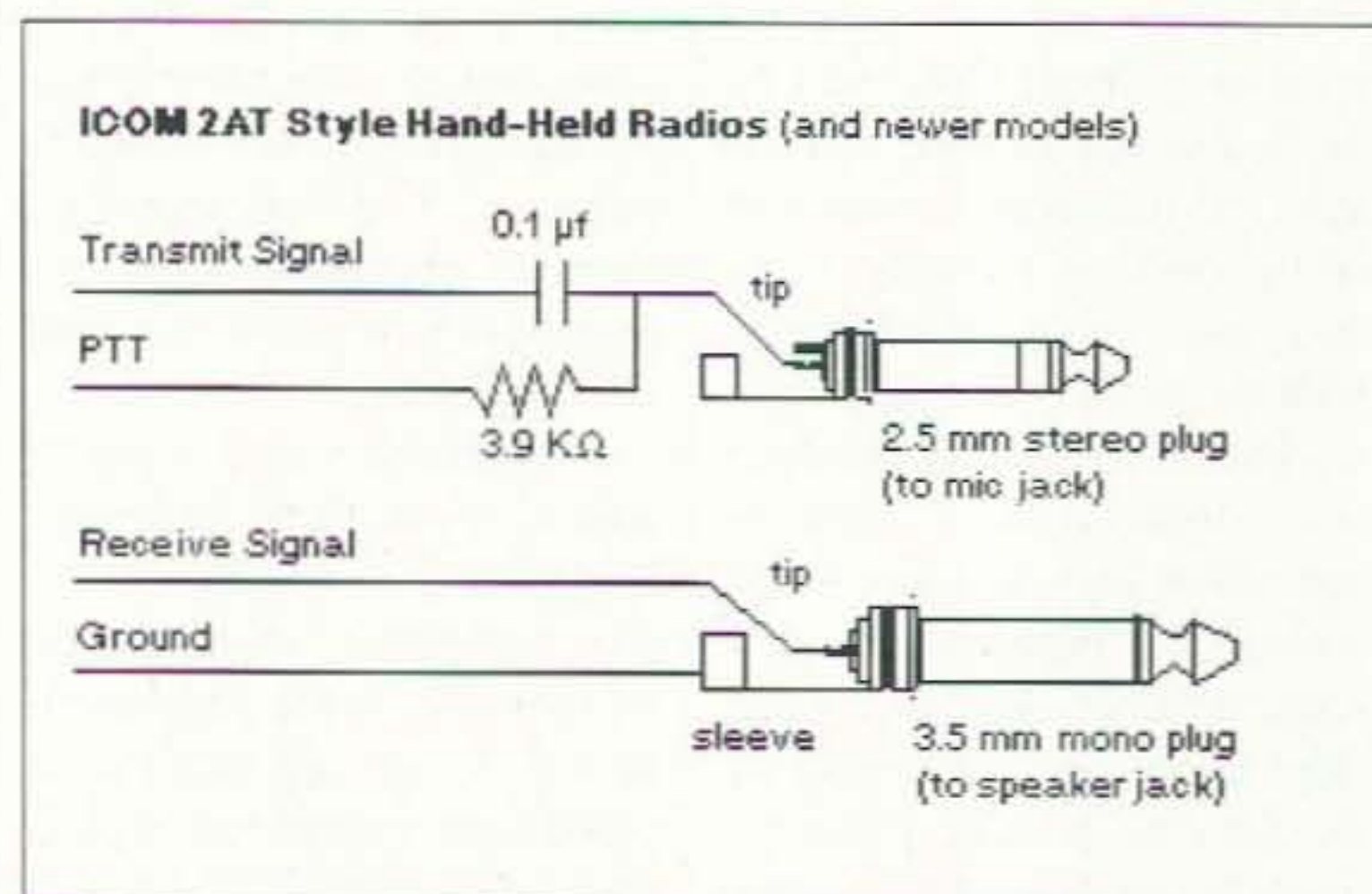

Fig. 1. The diagram can be found at [http://prairie.lakes.com/~medcal/ztx/wire/i2at.html]. Note—The 2AT uses a mono plug for the mike jack.

Joseph J. Carr K4IPV
P.O. Box 1099
Falls Church VA 22041-0099
[carrjj@aol.com]

Receiving loops & loop preamplifiers: part 1

Small loop antennas are popular for radio direction finding (RDF), foxhunting games, and for improving reception on the lower bands. Surprised? The fact is, even though small loops have less gain than, say, a dipole, the fact that they have deep nulls and are easily rotated make them ideal for reception on very crowded bands. The idea is to improve the apparent signal-to-noise ratio (SNR) by sharply reducing the amplitude of interfering signals. Reception is, after all, a game of SNR with the desired signal competing with QRM and QRN.

Fig. 1 shows the basic form of a square loop antenna. You can build small loops in any shape, but the square is easiest to construct. Other shapes include the circle, the hexagon, the octagon and the equilateral triangle. Before proceeding,

let's define small loops vs. large loops.

Small loop antennas defined

Large loop antennas are those with overall wire lengths of 0.5λ to more than 2λ . Small loop antennas, on the other hand, have an overall wire length that is much less than one wavelength (1λ). According to a World War II US Navy training manual, such antennas are those with an overall length of $\leq 0.22\lambda$. Jasik's classic 1961 text on radio antennas uses the figure $\leq 0.17\lambda$, while John Kraus (1950) used the figure $\leq 0.10\lambda$. An amateur radio source, *The ARRL Antenna Book*, recommends $\leq 0.085\lambda$ for small loop antennas. For purposes of this article we will use Kraus' figure of $\leq 0.10\lambda$.

A defining characteristic of small loops versus large loops is seen in the current distribu-

tion. In the small loop antenna the current flowing in the loop is uniform in all portions of the loop. In the large loop, however, the current varies along the length of the conductor, i.e., there are current nodes and antinodes.

The small loop antenna also differs from the large loop in the manner of its response to the radio signal. A radio signal is a transverse electromagnetic (TEM) wave, in which magnetic and electrical fields alternate with each other along the direction of travel. The large loop, like most large wire antennas, responds primarily to the electrical field

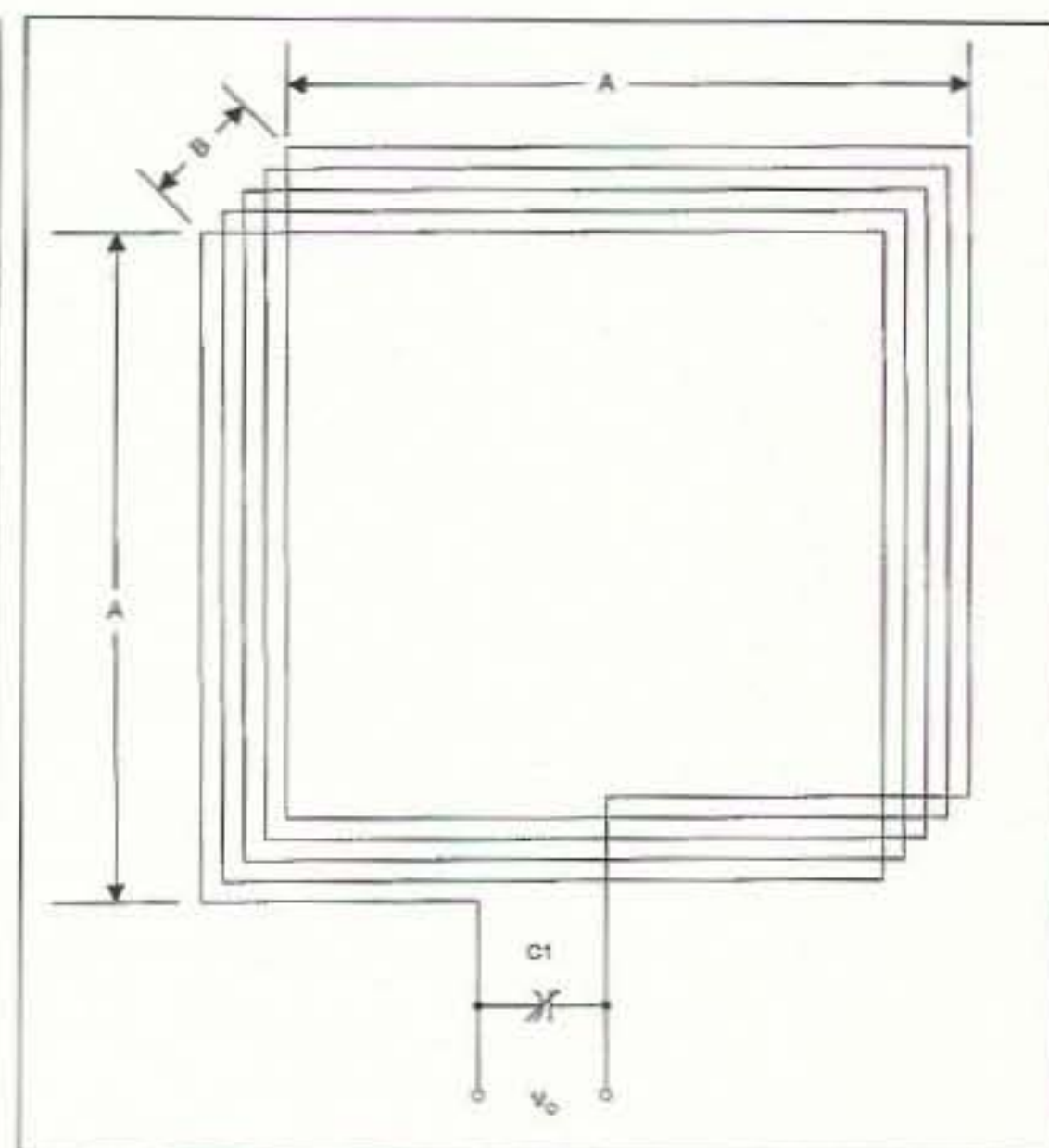

Fig. 1. Structure of the loop antenna.

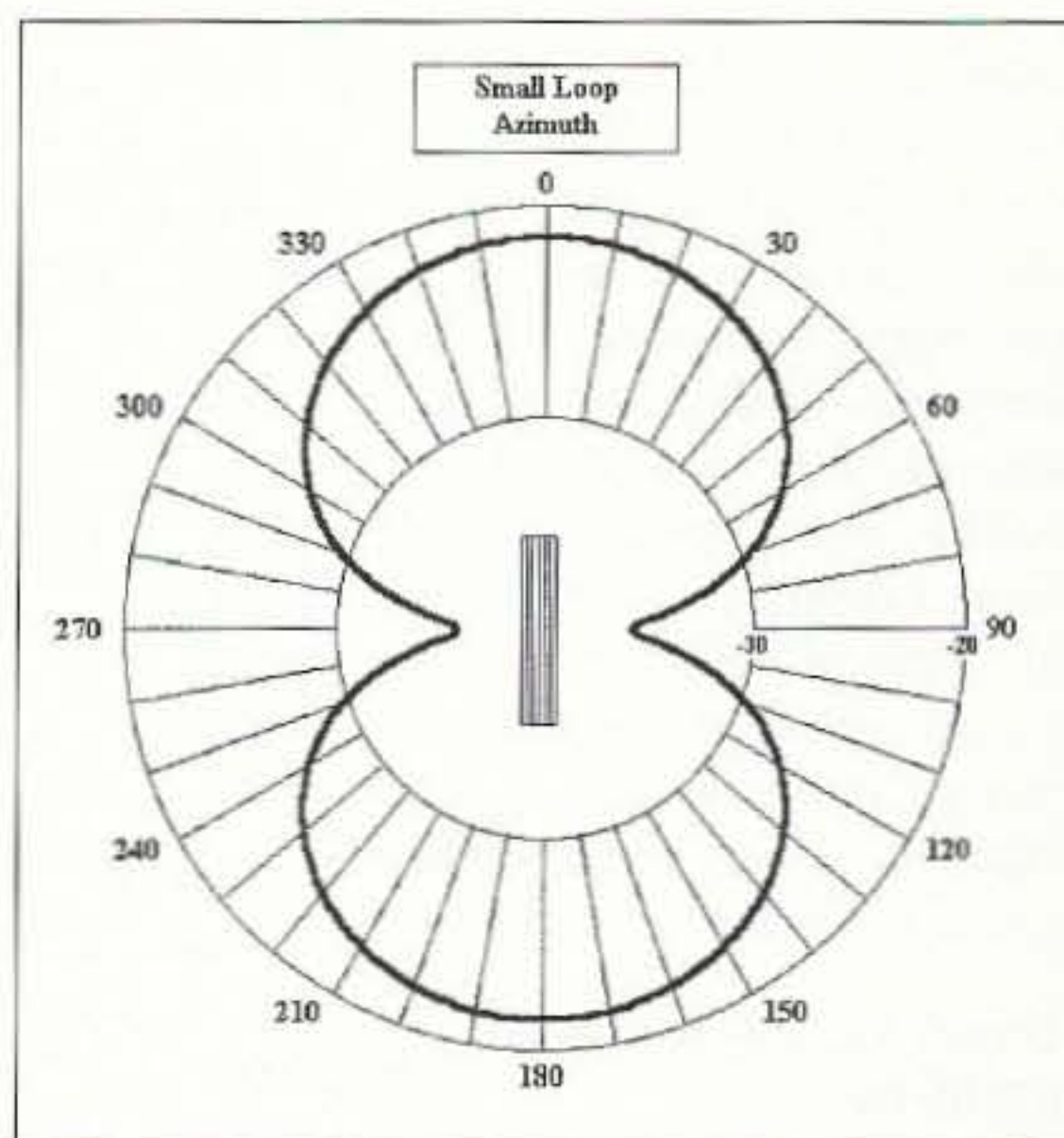

Fig. 2. Directions of maximum and minimum azimuthal response.

I did it, having no shortage of wire.

Some other advice included careful adjustment of the 2AT volume control as well as the threshold control on the 232. Eventually, I plugged it all in. Not watching the activity on the front of the 232, I brought up the XPWare program and, before I had a chance to reach for the knobs, there were a couple of lines of text from the local PBBS displayed.

I was excited! After such a dry period of experiments that didn't pan out, it looked like ... maybe ... by golly ... it'll work. Sure enough, I gave it the command to connect and after some

hesitation, the audio signal for "connected to" sounded and everything fell into place.

This has a particular advantage in that I can have both radios, HF and VHF, connected to the same TNC. This eliminates switching cables and life is back to "normal." The only problem? My wife gets a little suspicious when I come out of the shack smiling.

Conclusion

What I alluded to at the beginning of this article is confirmed. Those of us with SoundBlaster cards will not be using them for packet until

someone writes a driver for them. When they do, there will be a whole new world open to us. Soon to follow will be all the other digital modes.

The serial modems, which appeared to be toys to many of us a few years back, are well developed. They work well for packet and a new breed even runs 9600b. The HF serial modems are capable of excellent communication—more software is being developed and experimentation continues.

The old-fashioned TNCs like I'm using will be around for a good while. One of these days, though, they will be another item we "look back on." Such

is progress—in a form that makes it fun to try to pass along my experiences to you in future columns.

A note: in February's column, the Web address listed for "K7SZL's Unofficial HamComm Home Page" should have been [www.accessone.com/~tmayhan].

If you have questions or comments, E-mail me at the address at the head of the column and/or CompuServe [72130,1352]. I will gladly share what I know or find a resource for you. On packet, when you get a chance, drop me a line [KB7NO @ N7NPB.#NONEV.NV.U.S.A.NOAM]. For now, 73, Jack KB7NO. 

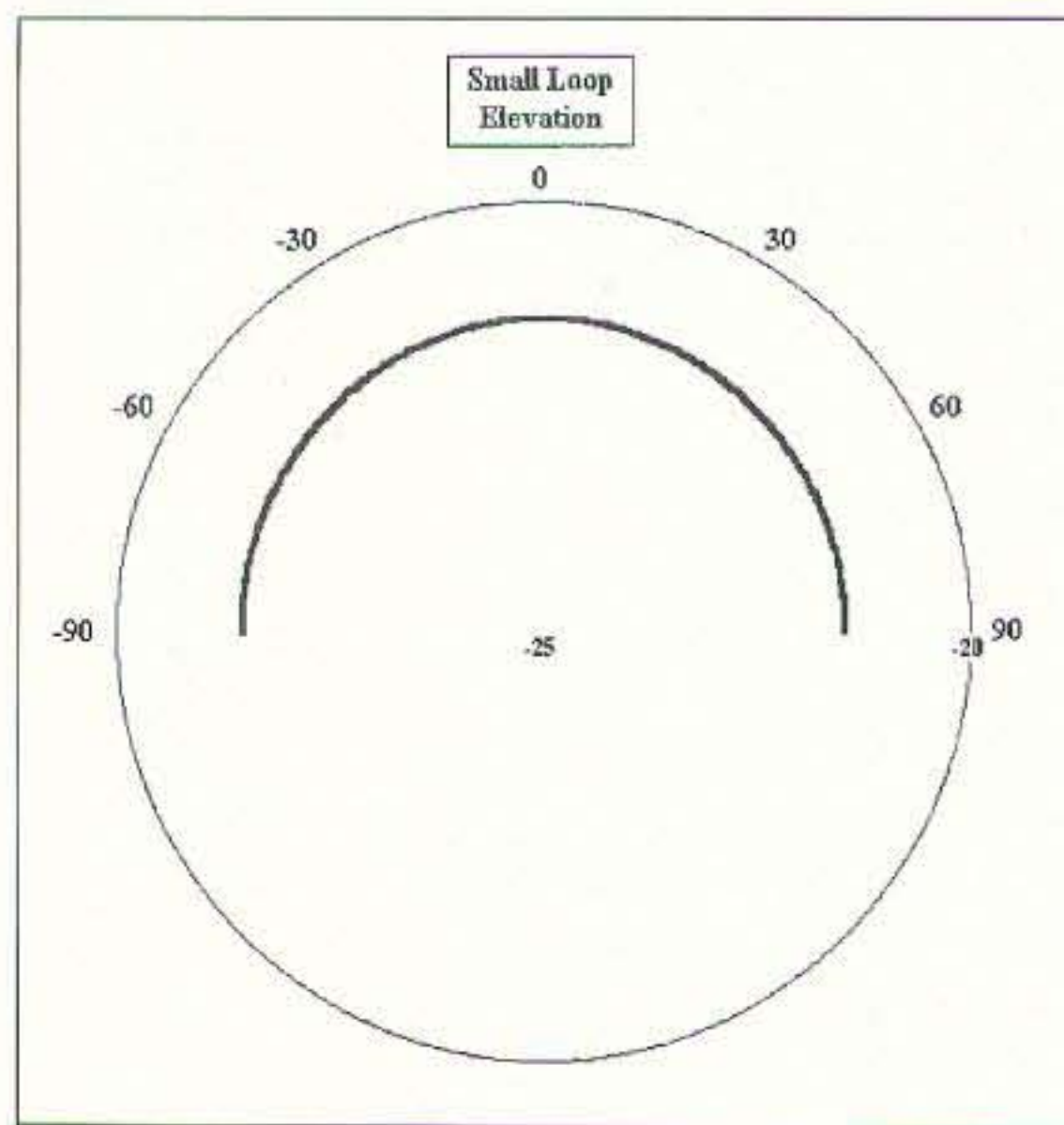

Fig. 3. The elevation aspect of the loop pattern.

component of the TEM, while small loops respond mostly to the *magnetic field* component. The importance of this fact is that it means the small loop antenna is less sensitive to local electromagnetic interference sources, such as power lines and appliances. Local EMI consists largely of electrical fields, while radio signals have both magnetic and electrical fields. With proper shielding, the electrical response can be reduced even further.

Small loop antenna patterns

Small loop antennas have patterns opposite those of large

loops. The minima, or "nulls," are perpendicular to the plane of the loop, while the maxima are off the ends. Fig. 2 shows the directions of maximum and minimum azimuthal response. The loop antenna is viewed from above. The nulls are orthogonal (at right angles) to the loop axis, while the maxima are along the loop axis.

This is a simulation of a loop pattern, run on the *Nec-WIN Basic* software. The basic model was for a loop that is $\leq 0.10\lambda$ at 1,000 kHz. The azimuthal (horizontal) pattern is shown in Fig. 2, with a top view of the loop superimposed. Note the pattern

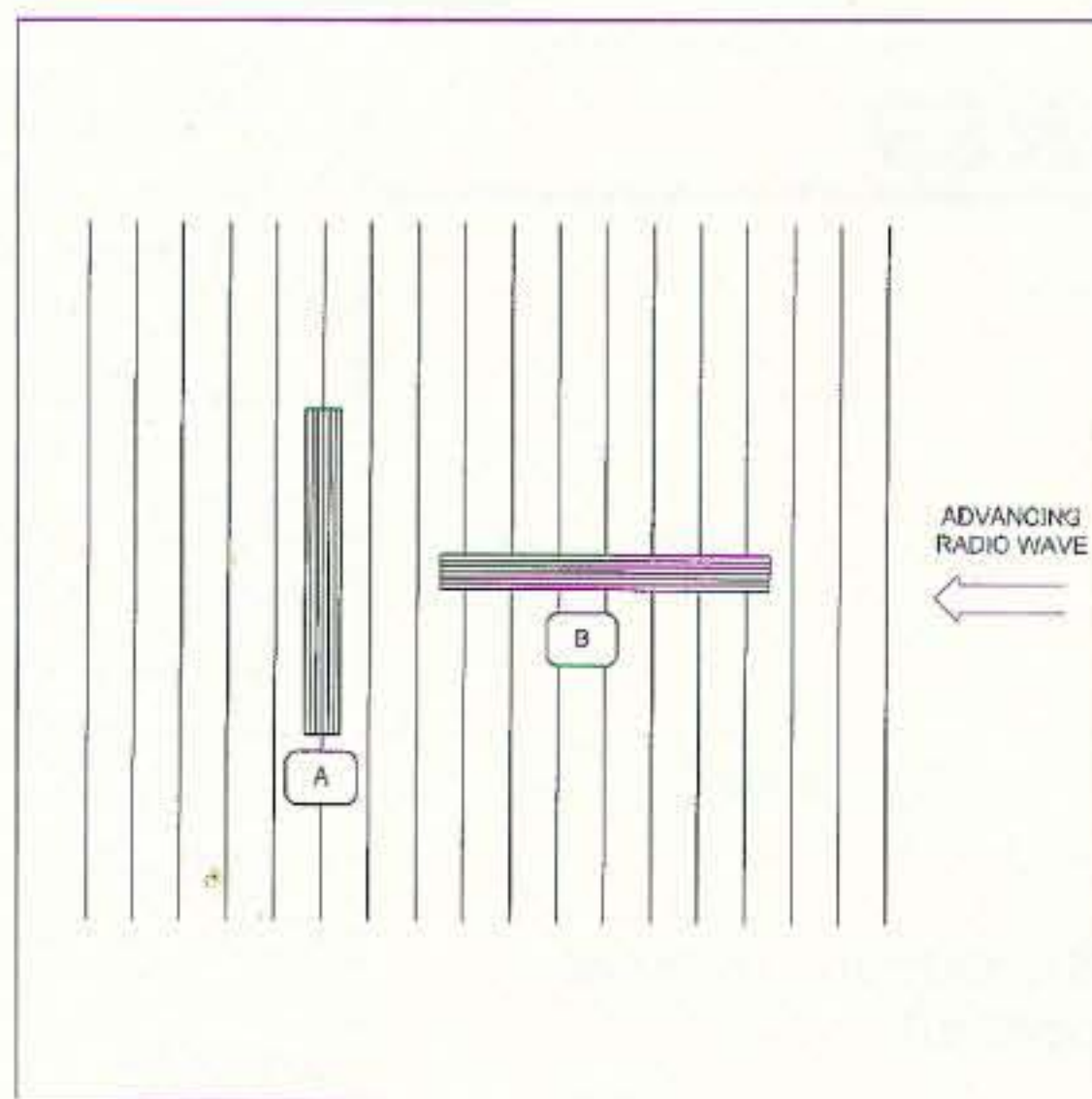

Fig. 4. Why loops produce nulls perpendicular to their plane.

"pinches in" along the line perpendicular to the loop axis (90° and 270°), and blooms out (indicating higher gain) along the loop axis (0° and 180°).

The elevation (vertical) aspect of the loop pattern is shown in Fig. 3. This is the "side view" of the loop pattern. The plane parallel to the Earth's surface is along the -90° to $+90^\circ$ line, while straight up (perpendicular to the Earth's surface) is the line from horizontal to 0° . This pattern shows equal gain in all elevation angles above horizontal.

The fact that the small loop pattern has nulls perpendicular to the loop axis, i.e., perpendicular to

the plane of the loop, is counterintuitive to many people. The situation for two identical loops is shown in Fig. 4. The advancing radio wave produces alternating regions of high and low amplitude. The lines in Fig. 4 are *isopotential* lines, i.e., the signal voltage is the same at all points along the line. A *potential difference* exists between any two lines. The loop antenna marked "A" in Fig. 4 is aligned such that its axis is parallel to the isopotential lines, while the axis of the antenna marked "B" is perpendicular to the isopotential lines.

Increasing small loop performance

Small loop antennas produce very low output signal levels, especially when untuned. The output voltage can be increased substantially by providing a tuning capacitor (Fig. 5). The output voltage increase is proportional to the Q of the tuning capacitor, which can be on the order of 10 to 1,000, with 50–100 being most common.

Two versions of the tuning scheme are shown in Fig. 5. The variety in Fig. 5a tunes the main loop. A small coupling loop (one to three turns) is provided to actually deliver signal to the receiver. The output of this loop will be approximately 50–100 times higher than the same loop without capacitor C1. The loop inductance can be calculated using equations in *The ARRL Antenna Book*, or by using the *Windows* software on the CD-ROM that comes with my

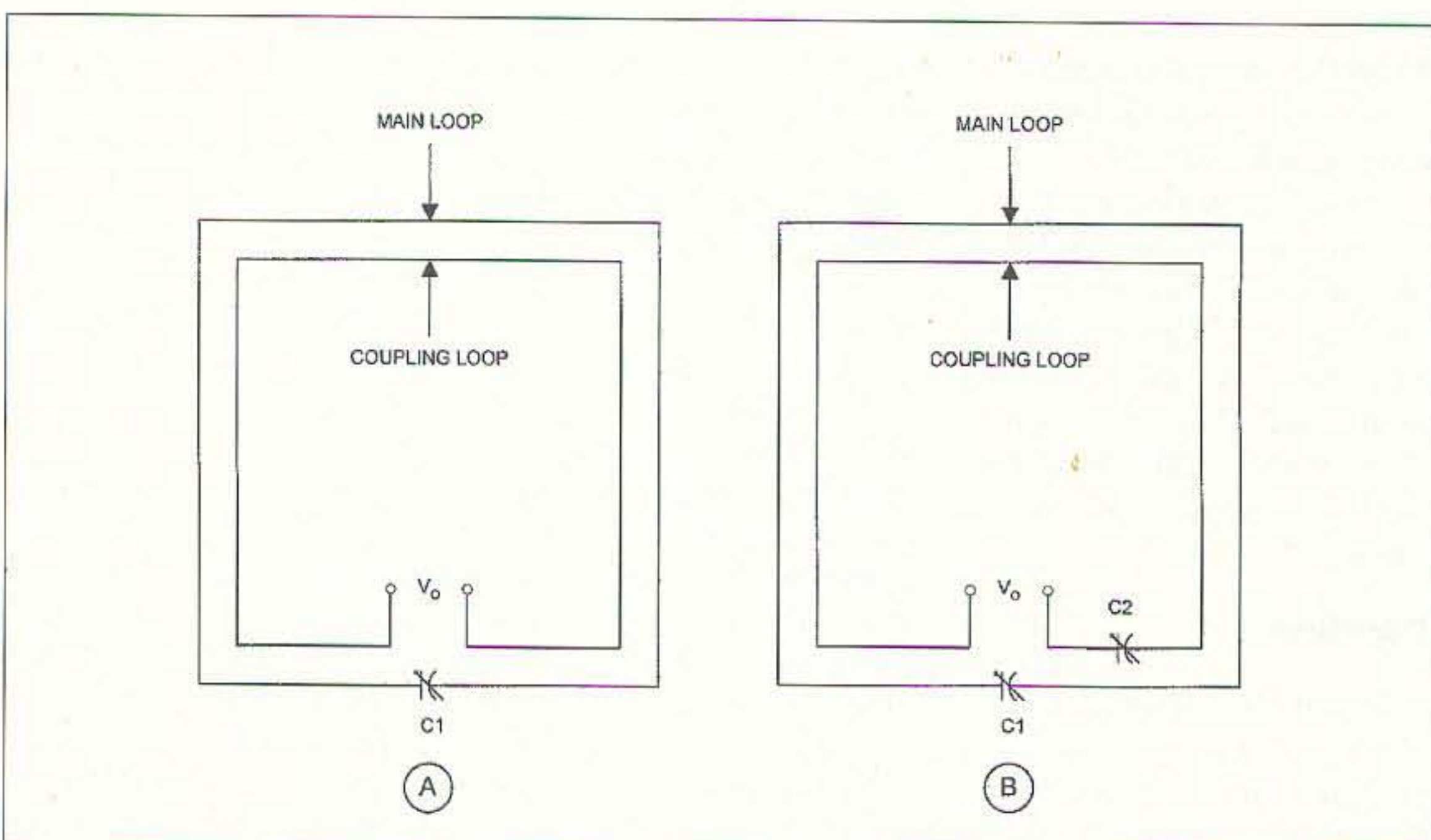

Fig. 5. Tuning loop antennas (see text).

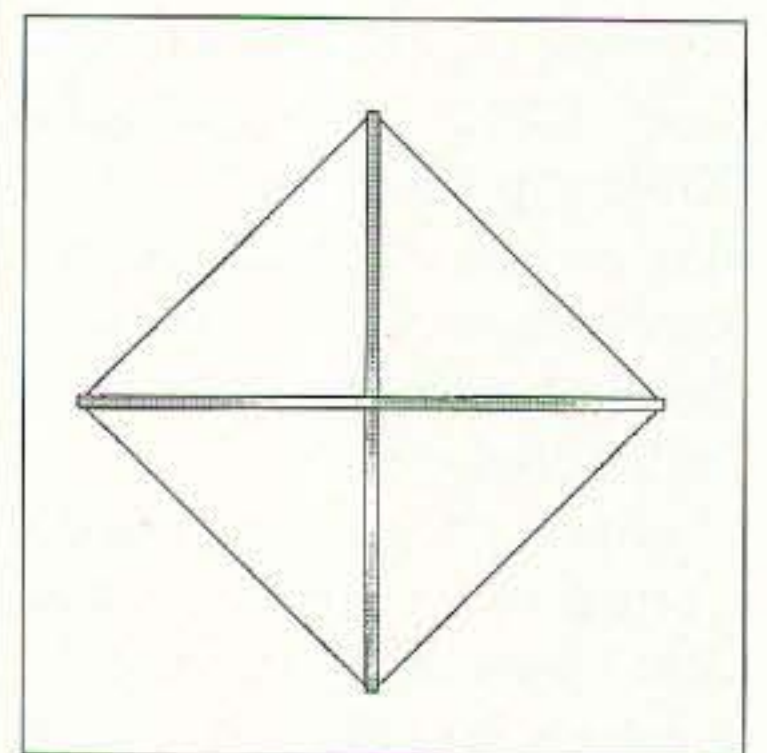

Fig. 6. Basic form for loop construction.

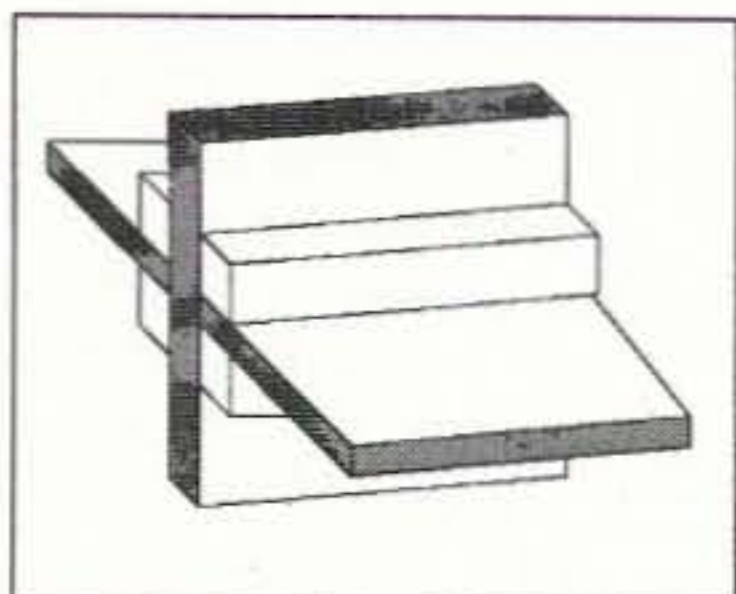

Fig. 7. Center piece detail.

Butterworth-Heinemann book *Antenna Toolkit*. The same software also allows you to calculate the resonating capacitance, and the dimensions of a large number of other antennas. If you are interested in my book, *Antenna Toolkit*, contact B-H [225 Wildwood Avenue, Woburn MA 01801-2041; or call Sales at (781) 904-2603 (voice), (800) 366-2665 (voice), or (781) 933-6333 (FAX)].

The second form of tuning is shown in Fig. 5b. In this variation on the theme both the coupling loop and the main loop are tuned. Capacitor C1 tunes the main loop, and C2 tunes the coupling loop. Because the coupling loop has fewer turns than the main loop, it has a smaller inductance. This means that the resonating capacitor for the coupling loop (C2) must be considerably larger than the capacitor for the main loop (C1).

Loop construction

The square loop is, by far, the easiest to construct. You only need to cross a couple pieces of flat wood. Fig. 6 shows the basic form of this

type of construction. The wood pieces are crossed, and the wire stretched across the ends.

The type of wood that is most suitable depends on the size of the loop. For reception in the AM BCB through, say, the 40-meter ham band, you can obtain strips of trim wood from large do-it-yourself hardware and lumber stores. I have seen one-inch-wide by one-quarter-inch- or three-sixteenths-inch-thick wood, and the same thickness in one-and-a-half-inch wide. For LF and VLF frequencies below the AM BCB (e.g., a 60 kHz WWVB receiver), use three-inch-wide by 24-inch-long spruce strips. These are available in hobby stores that sell to model builders. The spruce is (usually) in the same display with the balsa wood, so be careful to get the stronger spruce stock.

Fig. 7 shows how the crosspieces are fitted together. The two strips are cut to equal lengths (e.g., 24 inches). A notch is cut halfway across each strip at the exact center. Smear carpenter's glue or Elmer's® in the notches, and join them together. You will also want to cut some three-eighths-inch- or half-inch-square strips to lengths equal to the width of the main strips. Glue them into the corners of the crossed pieces as shown in Fig. 7. It is wise to use small wood screws to keep these pieces of lumber held together. While the glue is still damp clamp the assembly into a position in which the two

crosspieces are perpendicular to each other.

The ends of the crosspieces are prepared as shown in Fig. 8. Two forms are shown. The left-hand side uses a series of small holes drilled about one-quarter inch from each end. The right-hand side uses slots cut from the edge for about one-quarter inch. The holes can be drilled using the small drill bits used for 0.04-inch printed circuit board holes. Reduced shank drill bits are available that allow them to be used in any drill that accepts one-sixteenth-inch bits. Alternatively, you can get similar bits for a Dremel Moto-Tool™, or equivalent. The slots are cut using a jeweler's saw with a thin blade. The idea in either case is to make an opening that will accept #26 enameled wire without allowing it to slip around.

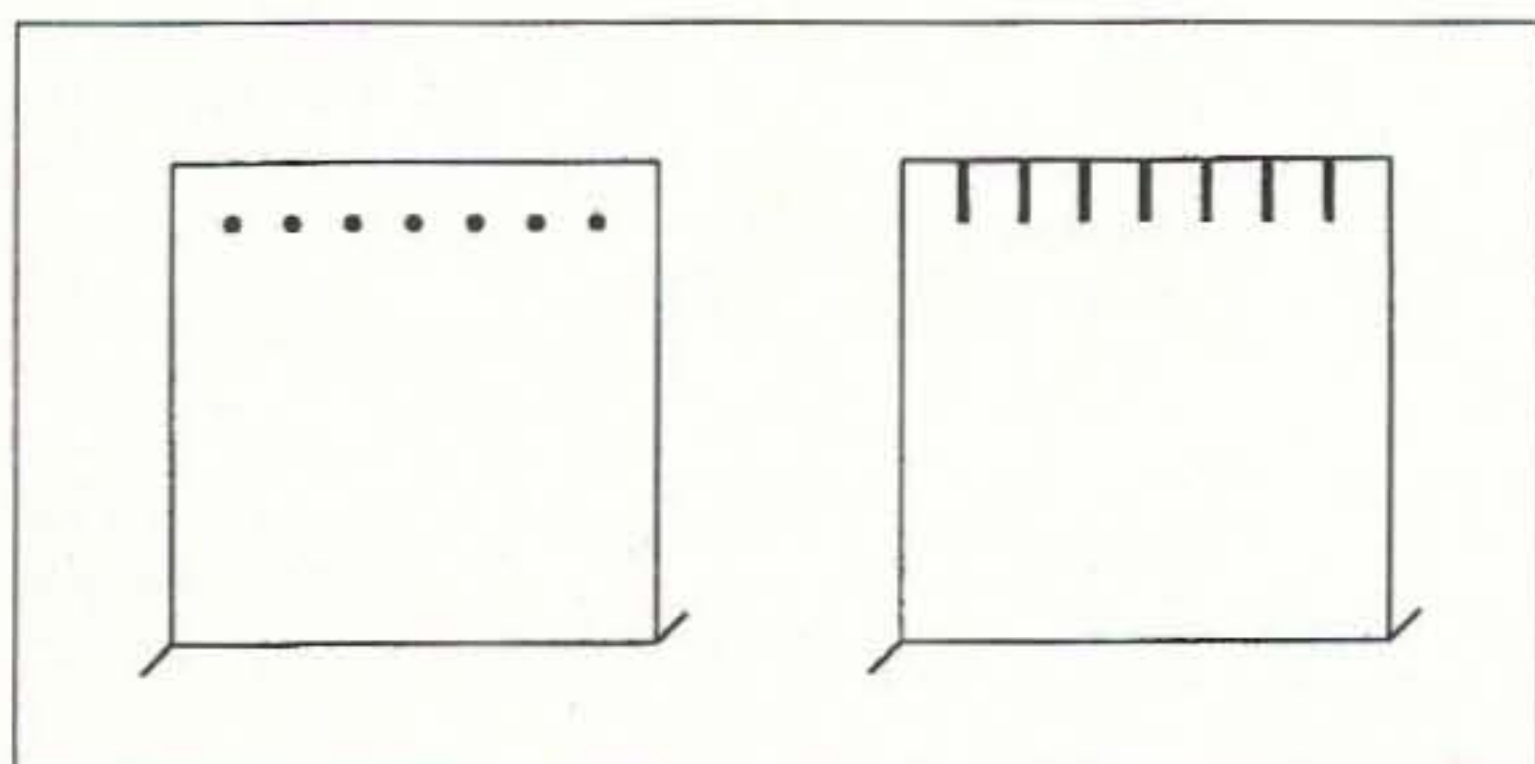

Fig. 8. End details.

Radio Bookshop

Phone 800-274-7373 or 603-924-0058, FAX 603-924-8613, or see order form on page 88 for ordering information.

Rene's Books

NASA Mooned America. René makes an airtight case that NASA never landed anyone on the moon. Ridiculous, of course, so maybe you can be the first to find fault with René's 30 "gotchas." He sure convinced Wayne. \$28.

The Last Skeptic of Science. René blows holes in one cherished scientific dogma after another. Do you believe there have been ice ages? That the moon causes the tides? That the iron core of earth causes its magnetic field? That the transmutation of elements is difficult? Another \$28 well spent.

If you are a No-Code Tech, and you're having fun operating, tell us about it! We'll pay you for your articles. Send your stuff to Joyce Sawtelle, 73 Magazine, 70 Route 202 N, Peterborough, NH 03458.

WE DON'T BUILD THE MOST, WE JUST BUILD THE BEST!

- Our LM-470D is now redesigned to hold 15 ft. of antennae at 70 mph!
- Tri-Ex builds the finest in crank-up, free-standing or guyed towers.
- All towers are complete with rigid concrete base mount.

CALL
OR WRITE
FOR A FREE
CATALOGUE!



Tri-Ex
TOWER CORPORATION

7182 Rasmussen Ave. • Visalia, CA 93291

Where engineering and quality come first!

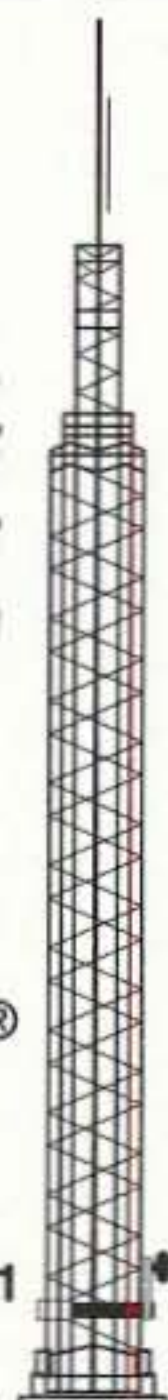

TO ORDER CALL
800-328-2393

FAX
209-651-5157

CIRCLE 22 ON READER SERVICE CARD

ON THE GO

Mobile, Portable and Emergency Operation

Steve Nowak KE8YN/4
1011 Peacock Ave. NE
Palm Bay FL 32907-1371
[pangen@compuserve.com]

Repeater problems

In most of the amateur radio bands we select an available frequency and communicate with another station. In the most popular UHF and VHF bands we tend to look for a crowded frequency and join in with many other stations. This is not called a pileup—it is called using a repeater. Repeaters allow us to use a frequency which normally would support only short, line-of-sight communications over much longer distances. They also add a whole new aspect to the hobby, since they tend to act as electronic neighborhoods for people with common interests. Some of these interests are practical in nature, such as Amateur Radio Emergency Service (ARES), Radio Amateur Civil Emergency Service (RACES), or SkyWarn for spotting bad weather for the National Weather Service. Others are more hobby- or socially-related.

In a small community, most of the local hams may be limited to a single repeater, but in a large metropolitan area there are a number of repeaters, each of which may be quite different from the others. Perhaps this diversity is because many repeaters are sponsored by clubs, and different clubs tend to have different interests. One repeater may be more oriented toward the hardware and experimental group. Another might be geared toward the public service aficionados or maybe the computer types. Long before the Internet had chat rooms and news groups, the selection of repeaters offered forums for hams with common interests. While a repeater is like a neighborhood, like any other neighborhood it

is subject to being invaded by certain unsavory types who do not belong and are unwelcome.

With the growth of our hobby, equipment availability has mushroomed. While this has had many good effects, one of the bad ones is that unlicensed individuals can easily obtain ham radio equipment and some choose to operate it without bothering to get a license. While it may take some effort to construct an antenna and put

“Even though there is the deep-felt desire to punch the offending operator in the nose, this is a questionable approach.”

a station on the air for 75 meters, a two-meter station is easy to operate; requires no external antenna beyond the rubber ducky; and is portable, easy to conceal, and therefore perceived as hard to detect. Certain individuals then take delight in interfering with local repeaters and/or seeing how angry they can make the legitimate amateurs who use that repeater. What are the legitimate amateurs to do in such cases?

While it is the first reaction of many hams to key the microphone and order the offending party off the air, I don't believe that this has ever been successful. First, the interloper now knows that his transmissions are being heard, and that he's gotten a reaction. Second, it is illegal to communicate with an unlicensed station. FCC Part

97.111 lists those types of transmissions which are specifically authorized. Those not authorized are illegal. Two wrongs don't make a right, but they can make for two citations. As they say, “Never wrestle with a pig—you both get muddy but the pig likes it.”

What can be done about such illegal users of the amateur frequencies? The repeater trustees should routinely monitor repeater operations. If unlicensed operators are heard, a number of safeguards can be used to limit the use of a repeater to legitimate users. CTCSS or “PL” systems use subaudible tones which are transmitted simultaneously with the voice message so that the repeater recognizes only those signals which contain the correct tone. Most modern

transceivers have this capability built-in, and encoders can be added to most older model rigs. If the intruder is not aware of such practices, this may be sufficient to solve the problem. In some cases, though, it may be necessary for the trustees to take the repeater off the air when the offending party begins to transmit. Locking the door to keep intruders out is not an unreasonable response.

The ARRL has operators in the Amateur Auxiliary designated as Official Observers whose purpose is to assist the FCC by compiling data on violations. The FCC, like many government agencies, has been subject to shrinking budgets in these days of downsizing. The League maintains a database so that the most serious cases can be identified to help the FCC

determine where it can most effectively allocate its resources.

A problem which is to be reported to the FCC starts with a written complaint containing as much relevant information as possible. This would include frequencies used, types of operation, hours of operation, etc. If your radio club has a foxhunting group, direction finding information may also be useful. The advantage of using the League's Official Observers is that they are not only more familiar with the FCC's requirements, but they are also willing to help out on the paperwork. Personally, I always prefer it if someone else is willing to do the paperwork.

There are a number of knee-jerk responses that should be avoided. If you get a good triangulation on the offending operator, some think the next step is to confront him. Even though there is the deep-felt desire to punch the offender in the nose (either literally or figuratively), this is a questionable approach. Such actions not only open the individual ham to criticism or possible legal action, but also tend to reflect poorly on the entire hobby.

Amateurs often question why there is no prohibition against non-amateurs owning amateur transmitting equipment. In the olden days transmitters and receivers were discrete devices, whereas today the transceiver is the rule. Some people want to use only the receiving capabilities, especially those who wish to receive while working toward their ticket. I have to admit, when I passed my General Class test and was waiting the interminable six weeks for my license to arrive, I purchased a two-meter HT and intently listened to every local repeater. I had decided which repeaters were my favorites, had programmed them into memory, and was on the air approximately .01 nanosecond after opening the envelope from the

Continued on page 59

HAMS WITH CLASS

Carole Perry WB2MGP
Media Mentors Inc.
P.O. Box 131646
Staten Island NY 10313-0006

A lesson of *Titanic* proportions

Over the past 18 years of teaching "Introduction to Amateur Radio" to 6th, 7th, and 8th graders at Intermediate School 72 in Staten Island, New York, I've had to change my teaching techniques and motivational lessons dozens of times in order to accommodate the changing times.

The classroom is a microcosm of society, and the advent of personal computers, satellites, cell phones, and the Internet have had a major impact on all our lives, including those of the students I teach. All the oohs! and ahhs! now have to be elicited through more innovative means. This year I seized upon the Hollywood success with the blockbuster epic *Titanic* to get the children excited at the start of the term.

I've always retold the famous saga of *Titanic* from the perspective of the radio communications.

But there has never been a grander way of doing it, thanks to the efforts of director James Cameron.

First, I took advantage of all the behind-the-scenes videos that were being shown on television and brought them into the classroom. The children were mesmerized by the footage of stuntmen, camerawork, flooding re-creations, and modelbuilding that the movie involved. When the bell rang at the end of each class session, nobody moved. They all wanted to stay and watch the end of my tape. Being totally enraptured with the romance and special effects and adventure of the whole story, they were more than primed for me to share the "real" radio story with them.

I chose some excerpts from the Fall 1997 RCA *Proceedings* magazine to read to them. There is a great article by Ray Minichiello in this issue called, "*Titanic* Tragedy Spawns Wireless Advancements." Here are

some of the details that kept the kids at the edge of their seats as I dramatically read to them about that most incredible event out at sea.

"The tragedy of the *RMS Titanic*—loss of life numbering 1,500 passengers the night of April 14, 1912—was a great tragedy that seems even greater when one considers that all 2,205 passengers might have been rescued if just a couple of things had happened differently.

"Little has been said (even in the movie) of the circumstances of the *Californian*, a passenger ship that was within sight when the *Titanic* struck the iceberg that caused it to sink. The *Californian* failed to acknowledge the distress flares of the *Titanic* or to turn on its wireless. The passenger ship *Carpathia*, 58 miles southeast of the *Titanic*, responded to the distress call and rescued 705 passengers in

lifeboats. The other 1,500 passengers had succumbed to the cold sea.

"The *Titanic*'s sinking generated an opportunity for many to profit on the meager details available. Most details were available through the late David Sarnoff, the Marconi wireless operator, atop the Wannamaker Building in New York City. Sarnoff handled traffic without relief for several days with the *Carpathia* and the shore station at Glace Bay, Nova Scotia.

"Since the disaster that night, stories, books, documentaries and films have emerged with variations of the facts. The fascination about the *Titanic* continues to attract the human soul."

I go on to read them more details about what the wireless room actually looked like. It's also important to understand

Continued on page 60

ON THE GO

continued from page 58

FCC. (Thank goodness for the much faster turnaround we have today!)

Finally, maybe some of the problems we are seeing can be avoided by rolling out the welcome mat. Some of those who listen on scanners to the local repeaters are potential hams, including those who may either become a member of the community or else pose a problem to it. During the local nets make sure there is information about upcoming classes which in-

cludes a telephone number for a point of contact. Future hams, Novices, and other amateurs who can monitor two meters but not respond will appreciate this. Don't forget that when the handie-talkie is in the shop, many of us still continue to monitor the nets. By opening the door, you may be able to draw a person into the hobby long before he or she decides to interfere with it.

Identifying a problem is easy. Complaining about it is easier. Finding a solution is harder, but most definitely worth the effort—especially for us. 73

AMATEUR TELEVISION

web site: www.hamtv.com

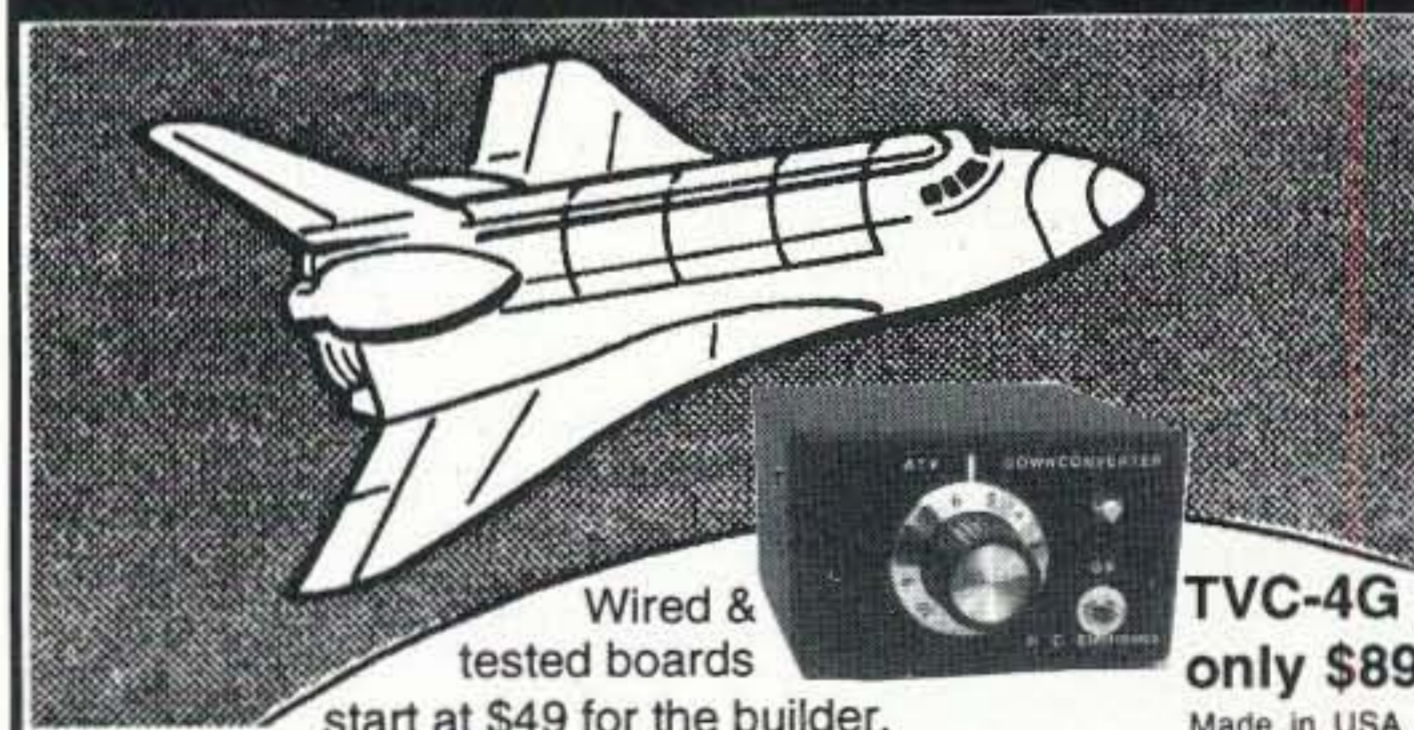

Wired & tested boards
start at \$49 for the builder.

TVC-4G
only \$89
Made in USA

SEE THE SPACE SHUTTLE VIDEO AND GET THE ATV BUG

Many ATV repeaters and individuals are retransmitting Space Shuttle Video & Audio from their TVRO's tuned to GE-2 (85W) Tsp 9 vertical or weather radar during significant storms, as well as home camcorder video from other hams. If it's being done in your area on 420 - check page 577 in the 97-98 ARRL Repeater Directory or call us, ATV repeaters are springing up all over - all you need is one of the TVC-4G ATV 420-450 MHz downconverters, add any TV set to ch 2, 3 or 4 and a 70 CM antenna (you can use your 435 Oscar antenna). You don't need computers or other radios, it's that easy. We also have ATV downconverters, antennas, transmitters and amplifiers for the 400, 900 and 1200 MHz bands. In fact we are your one stop for all your ATV needs and info. We ship most items within 24 hours after you call.

Hams, call for our complete 10 page ATV catalogue.

1-626-447-4565 M-Th 8am-5:30pm pst Visa, MC, UPS COD
P.C. ELECTRONICS Email: tomsmb@aol.com
2522 Paxson Ln, Arcadia CA 91007 24 Hr. FAX 1-626-447-0489

HAM TO HAM

Your Input Welcome Here

Dave Miller NZ9E
7462 Lawler Avenue
Niles IL 60714-3108
[dmiller14@juno.com]

Despite the fact that this is the April issue, there's no foolin' in this month's "Ham To Ham" column ... just good practical suggestions! By the way, if you have any that you'd like to see printed in a future issue, all you have to do is jot them down and mail (or E-mail) them to me at either of the addresses shown above. I'm always looking for more practical tips and ideas to grace these pages, so don't be

shy. There's a lot to cover this month, so let's get right to it.

First in line, Roger and Ron Block of PolyPhaser Corporation have put together a well-written series of tips and suggestions on how we can effectively protect our ham radio stations from the destructive effects of a lightning strike. Part 3 of that series was presented last month; Part 4 now follows.

Lightning protection— what your mother never told you, Part 4

Since the tower is a conductor, and is well grounded, all tower coax lines should be grounded (using approved grounding kits) at the top of the tower, close to the antenna, and at the base of the tower, before they head toward the indoor equipment. During a strike event, the tower and the coax lines will mutually share the strike energy. If the coax lines are not grounded as they leave the tower, or worse, if they are completely isolated from the tower, more energy could traverse the coax cabling toward the equipment than is conducted to the ground system by the tower. This large inductive voltage drop

may cause arcing between the coax lines and the tower, which could cause coax deterioration (pinholes in the coax jacket for moisture to enter later) or even complete destruction of the coax lines.

Since all towers have some inductance, leaving the tower at a point above ground will allow some of the strike current to continue on the coax line (both the center conductor and shield), and on toward the indoor equipment. If this current is allowed to reach your ham shack, it will follow the chassis to the electrical safety ground, raising the voltage levels in the cabinets to deadly magnitudes. Remember that inductive drop!

Even though the inductive properties of the coax cable appear to be beneficial, and some

HAMS WITH CLASS

continued from page 59

the primitive stage of wireless technology of that period.

"The generated signal of the spark transmitter was blunt and broad. Selectivity as a specification for receivers and bandwidth for transmitters was yet to be an established criterion. Hence, during close proximity operation of stations, whoever hit the air first occupied almost the entire spectrum, denying others within close range the ability to communicate unless a tuned circuit was employed to minimize the interfering signal.

"The precise frequency of the *Titanic* and *Californian* transmitters at the time of the incident is not known; nevertheless, whatever the separation, the poor receiver selectivity and the closeness of the two vessels allowed but one transmitter operation. The lack of regulations, as well as the lack of procedures governing wireless operators, resulted in the inevitable blow to the *Titanic*.

"Aboard the *Californian*, the wireless operator, Cyril Evans,

turned on his wireless to dispose of his routine traffic. Because of the close proximity of the two ships, however, the *Titanic* operator advised Evans to 'shut up,' as he was interfering with traffic to Cape Race, a shore station. Evans complied. Being the lone operator on the *Californian* and having worked a long day, Evans retired for the night—another unfortunate occurrence for the *Titanic*.

"The *Californian*, just 10 miles from the *Titanic*, had found itself in the same ice field earlier in the evening, at 11 p.m. Wisely, the captain of the *Californian* had ordered his ship to a halt. The *Titanic* struck the iceberg at 11:40 p.m., less than a minute following its sighting by the lookout, but the 'CQ/D' (General Call/Distress) was not initiated until 12:15 a.m., 35 minutes later.

"The *Californian's* first officer observed white flares shot into the sky from the *Titanic* but assumed them to be shooting stars or part of a celebration on board the 'unsinkable' ship. His uncertainty, nevertheless, prompted him to use the Morse light signal lamp

aimed at the *Titanic*, but he received no response.

"The *Californian* did not attempt to send a wireless inquiry to the *Titanic*. Because of this one failure, the fate of the 1,500 lives was doom. Evans, the *Californian's* wireless operator, had already retired, and no attempt was made to awaken him to assume his post at the key of the wireless station.

"Meanwhile, 58 miles southeast of the *Titanic* was the *Carpathia*. Its wireless operator, Thomas Cottam, was preparing to retire when by chance he initiated contact with the *Titanic* to advise its operator that the Marconi station at Cape Cod was attempting to contact him. The response from the *Titanic* was prompt, with an urgent message naming itself in distress and requesting aid. The *Carpathia* arrived at the scene at 4:15 a.m. On arrival, there was no *Titanic*. Only emptiness, except for the lifeboats containing 705 passengers. By 8:30 a.m., all survivors were picked up.

"The most significant result of the disaster investigations was the call for an International

Radio-Telegraph Convention to convene in London on July 5, 1912, for the purpose of establishing regulations and procedures governing wireless services aboard ships and ship-to-shore. Some of the regulations enacted are still in effect today, including 'SOS' as the universal distress call."

Depending on the interest of the class before me, I go on to give more details about follow-ups to the story. The children, like most of us, continue to be fascinated by this provocative incident. There's so much to have discussions about: human behavior in times of emergencies, the arrogance of pride and social standing, regulations governing safety at sea, radio technology and regulations, the many ironies that occurred that evening, etc.

I really love the idea of being able to bring into the classroom a media phenomenon to use as a motivational tool for my radio lessons.

The excerpts from Ray Minichiello's article are used with permission from the Radio Club of America, publisher of *Proceedings*. 73

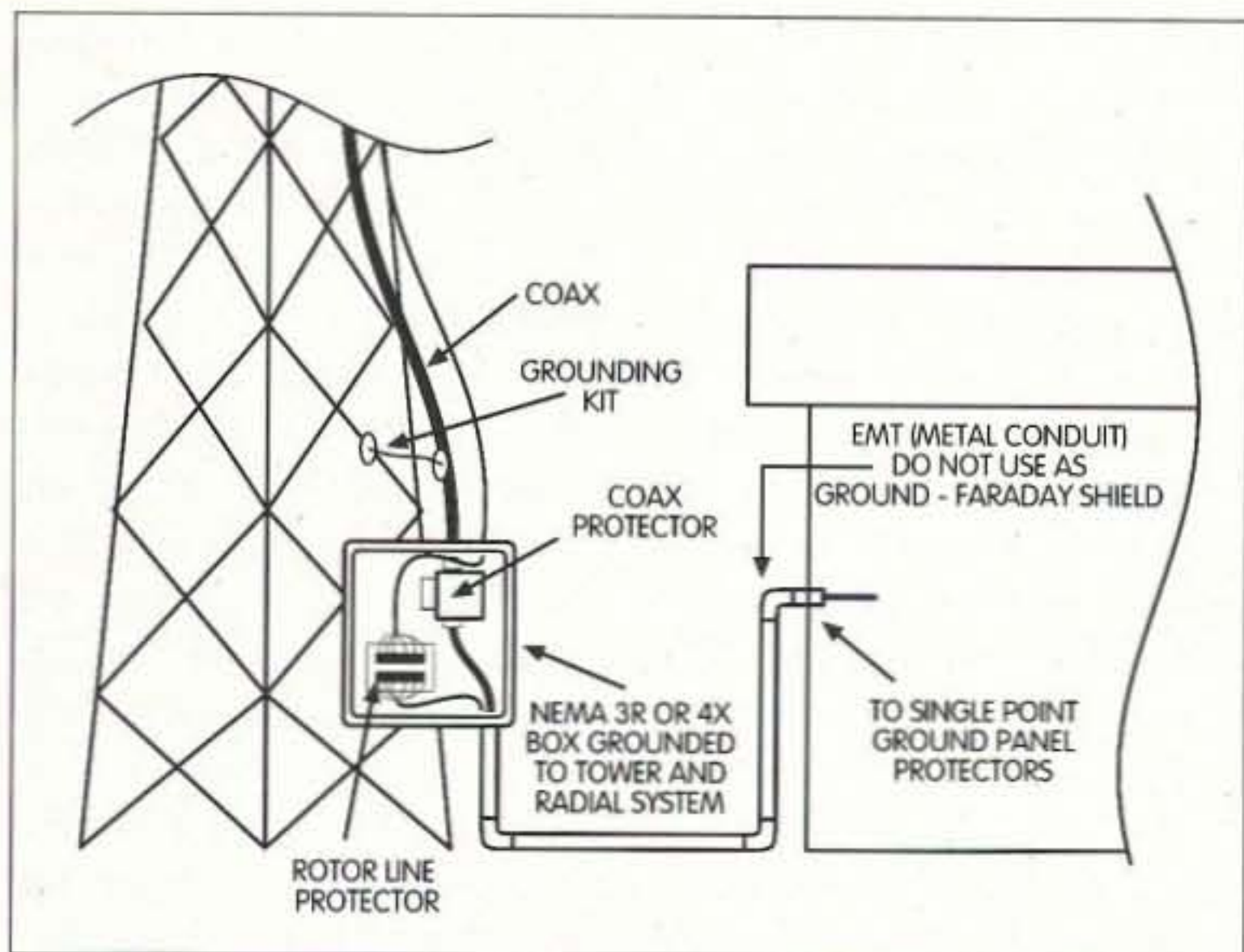

Fig. 1. An additional protection location and shielding plan for cables in a non-basement location.

extra inductance can be created by adding a few turns to the coax cable, it is not normally recommended. The added turns can act like an air-wound transformer, which can actually couple more energy into the line (via radiated pickup). This, obviously, is opposite to the desired effect. Additionally, the coax lines leaving the tower should remain at right angles to the magnetic field surrounding the tower for the least amount of magnetic coupling possible.

Rotor control and coax line protection

Rotor control lines should be protected using a suitable protector at both the top of the tower (where the lines enter the rotor motor), and inside the shack at the single point grounding panel. If it's not practical to protect the lines at the single point grounding panel, protect them at the base of the tower, then run them inside EMT (electrical mechanical tubing or conduit), grounding the conduit only at the tower base. The EMT conduit will act as a Faraday shield from the tower's magnetic fields, minimizing the amount of induced energy. Coaxial RF lines can also be protected from induced energy using EMT conduit, and again, grounded only at the tower base (see Fig. 1).

The single point grounding panel

The next step in any good lightning protection scheme is to provide a single point grounding panel, a plate upon which equipment I/O protectors can be located. The panel is best located near the main system ground, again, in order to keep the inductance of the earth ground conductor low. However, if this would require the panel to be too far from the protected equipment (more than 10 feet), and if the magnetic fields of a nearby tower could easily couple into the interconnecting wires and cables (after the single point panel), then the panel should be located closer to the equipment. An alternative (although not as good) to the single point grounding panel might be a dedicated equipment rack panel (if the station equipment is located in a standard equipment rack as is often found in an amateur repeater installation). This is recommended only if all I/O protectors are mounted on the panel and the earth ground connection is directly to the panel and not via any other piece of equipment. Grounding the panel is essential and only copper strap should be considered. Since the strap is flat, its susceptibility to induced magnetic fields is only with respect to its thinner edges. To prevent

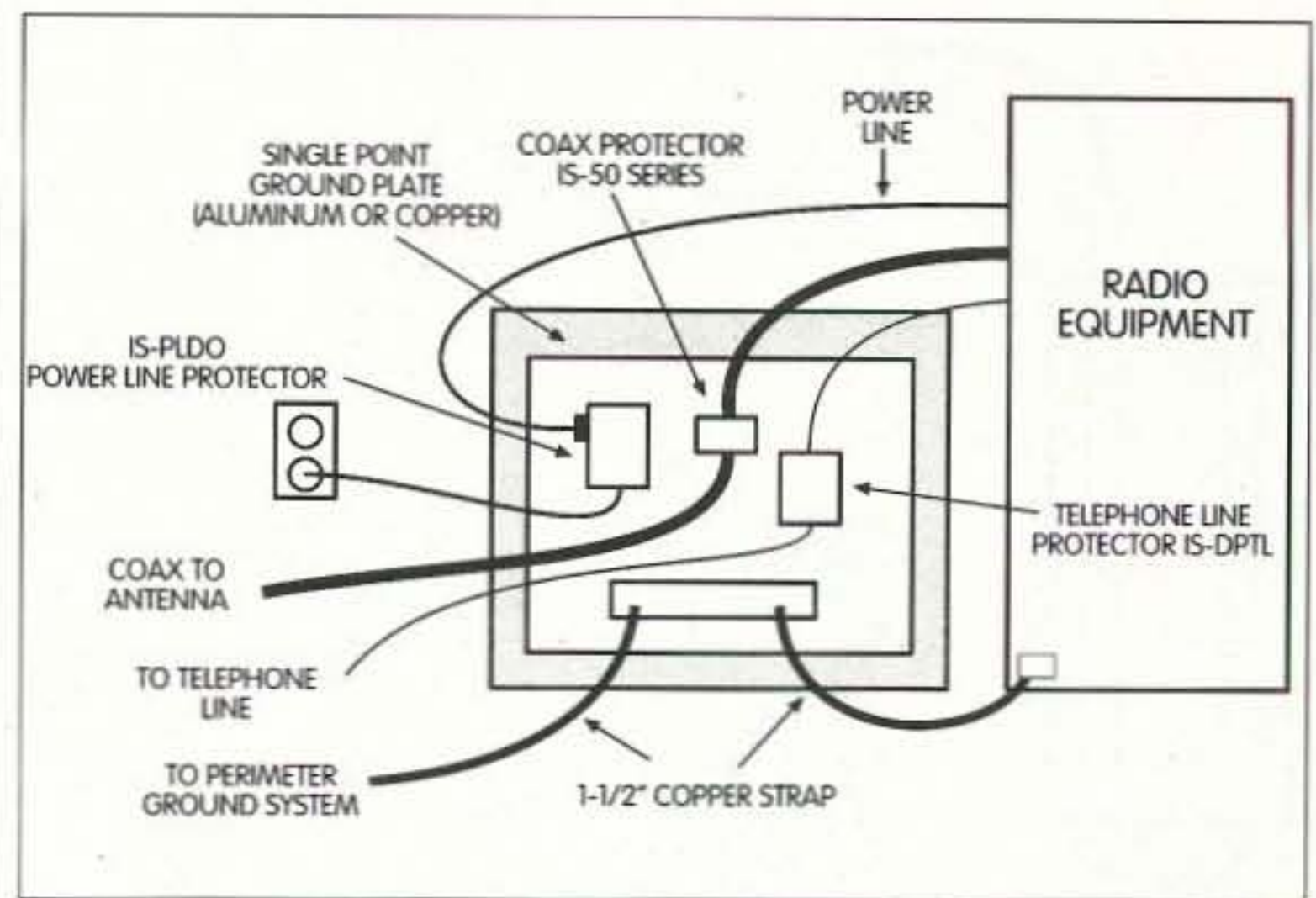

Fig. 2. Typical single point ground installation for rack-mounted equipment.

coupling, the strap should be positioned with the flat side parallel to the tower (the most likely strike point and source of a strong magnetic field). The single point grounding panel should be positioned so that its flat side parallels the tower for the same reason as mentioned for the earth ground strap. Direct grounding (with a heavy conductor) of each individual piece of equipment in a rack is essential if the equipment rack rails are painted (as is usually the case). Painted rack rails afford little in the way of an adequate ground when only part of the screw threads are actually touching ground. Fig. 2 illustrates one approach to a single point ground when rack-mounted equipment is involved, Fig. 3 shows how it might be accomplished for a desktop installation. Each installation is

different, so you'll have to adapt these examples to your own unique setup. But of greatest importance is understanding the basics, and always keeping those basics in mind when you set about to protect your own ham shack and tower installation.

In the operating or equipment room, each piece of equipment must be bonded to the single point grounding panel with a low-inductance copper strap. This will maintain all chassis potentials at the same level during a strike event, as well as minimize chassis-to-chassis current flow. The power, telephone and coax line protectors on each of the I/Os (equipment input/outputs) must be mounted on the single point panel as well. This will minimize I/O-to-I/O current flow.

Additional protectors should be used to safeguard the feed point or entrance locations for

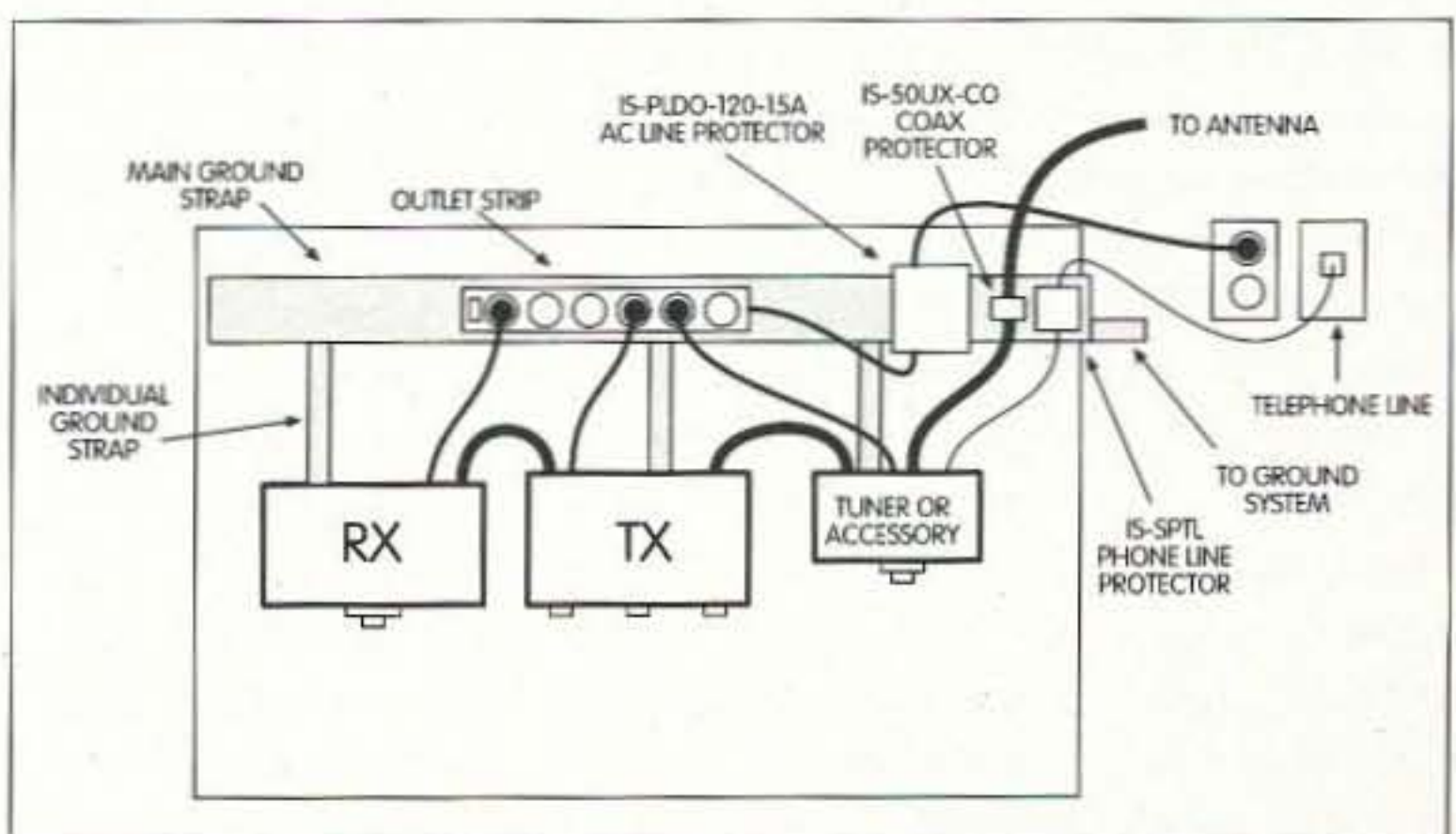

Fig. 3. Typical single point ground installation for tabletop-mounted equipment.

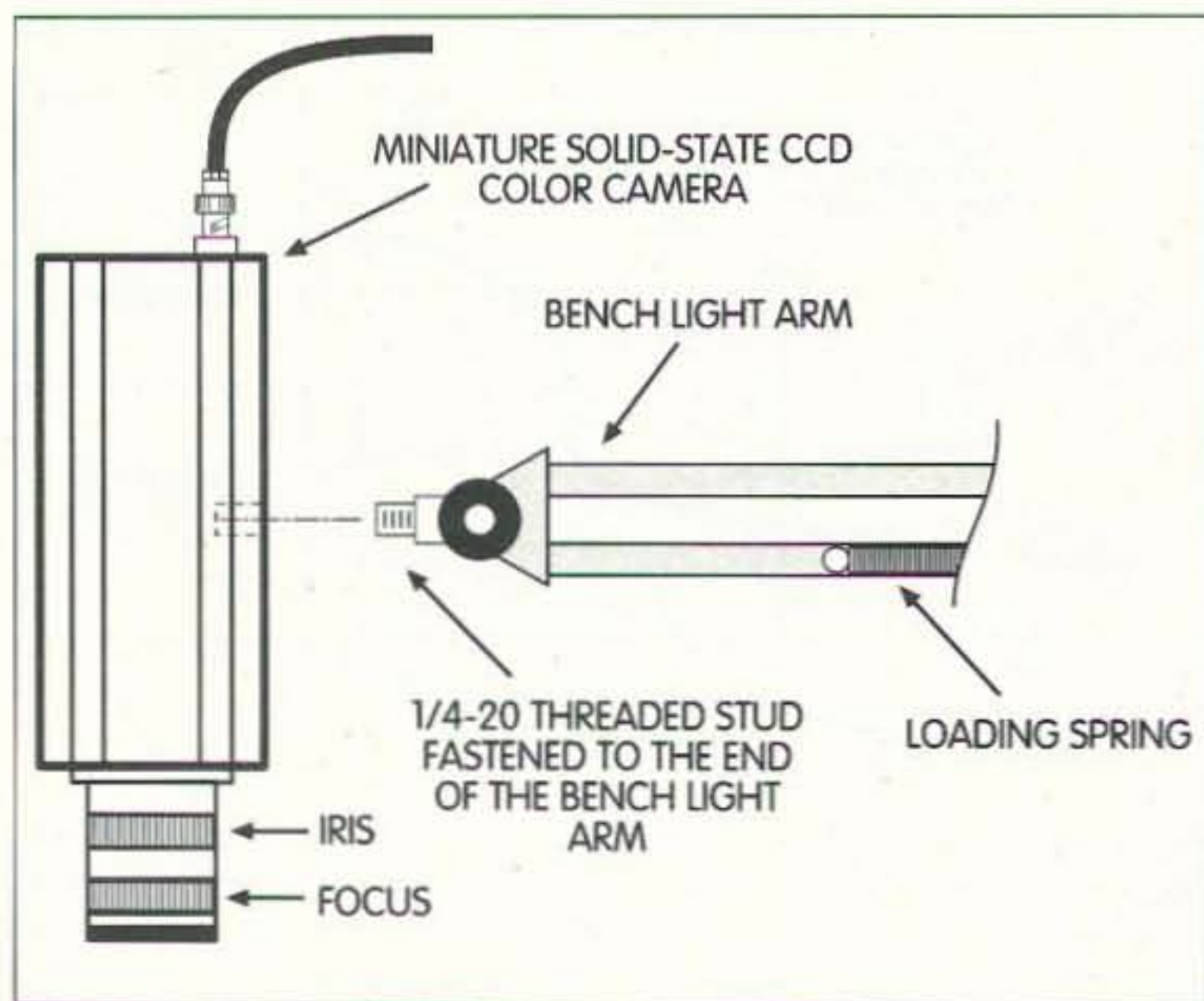

Fig. 4. The modification needed for the clamp-on bench light spring-loaded arm to accommodate the CCD TV camera. The actual details will probably vary from one brand of light arm to another.

the power and telephone lines. These will provide added protection for jointly used equipment such as answering machines, appliances, etc. Ideally, they should also be grounded and connected by a buried bare conductor to the ground system.

Surge energy can enter a shack in two ways: from a strike to the power or telephone lines, or from a strike to the tower. In either case, high-quality protectors will divert the energy into the ground system. Because of varying propagation delays of your ground, if the protectors are electrically separated from each other by a considerable distance, they cannot work in unison to keep the voltage levels between the equipment I/Os within a tolerable range for predictable equipment survival.

Moderator's note: Some of the preceding suggestions may seem like overkill, but please bear in mind that when we speak about lightning, we're talking about an extremely high-voltage, high-current event. Even small resistive or inductive drops can cause huge voltages to be developed ... especially in view of the very low voltages that our modern solid-state equipment is designed to tolerate. But much more important

than the equipment to be protected is the life and well-being of the operator ... you! Roger and Ron Block's series will return again next month with more of what mom never told you about lightning and how you can best protect yourself, and your station, from its destructive effects. This ongoing series is "must" reading for everyone who searches the ether in pursuit of that elusive rare one, whether you're a ham, SWL or general electronics enthusiast.

Tape tricks

Here are a couple of uses around the ham shack for plumber's Teflon™ thread-sealing tape that you may not have thought about.

I've found that, at times, plumber's Teflon tape can be used to bail me out when I've accidentally goobered up the threads in a plastic housing, and the screws just turn freely when I try to snug them up. Wrap several layers of Teflon tape around the screw threads and reinsert the screw into the stripped hole. Tighten it down fairly snugly, but not too tight, and the screw may just recover enough "grab" to begin to do its job again.

A wrap or two of Teflon tape around the threads of a PL-259/SO-239 coax connection that's

going to be used outside will help to keep moisture from getting into the connection (just as it prevents water from leaking out in its normal use on plumbing pipe threads). In fact, you might want to try wrapping the entire connection with the Teflon tape, then follow up with whatever sealing method you normally use for exterior coax connections (electrical tape, liquid plastic dip, black coax sealing putty, amalgamating tape, etc.). Since the Teflon plumber's tape is very thin and stretchable, it can usually be molded to cover up even irregular forms and shapes that need to be protected from the ravages of the elements.

Teflon tape wrapped around the threads of screws and bolts that are going to be used outdoors will sometimes help in preventing them from oxidizing and corroding in place as much as they otherwise would. If a thin, but reasonably complete, insulating and protective barrier can be established, electrolytic and chemical degradation of ferrous metals used outside can be slowed down (though perhaps not prevented entirely). Even just wrapping the exposed threads of a bolt being used outside will help make that bolt a little easier to remove when the time comes for disassembly—again, enlisting the tape's uncanny ability to conform to irregular shapes that need this outdoor protection.

Bigger is better

From Stan Strasburg W5TPS: "I've been using a special setup to help me to read the smallish print normally used in magazines and on many schematic diagrams, as well as to continue to work on my ham and electronics gear ... a pastime that I love. I have a degenerative eye condition that doesn't permit me to see clearly any longer—particularly small objects in their unmagnified state—but that doesn't have to stop me from enjoying my hobby and its many facets.

"The setup is easy to duplicate using today's electronics ... just use a 23-inch or 25-inch color TV set with a 'Video Input' option (most will have a video input these days), and a lightweight, color, miniature, all solid state (CCD) TV camera. Mount the CCD TV camera on a spring-loaded light arm (the type of arm that's used for most auxiliary clamp-on bench lights), and you're pretty much done! It's usually not too difficult to rig up a 1/4-20 adapter stud arrangement for mounting the lightweight camera to the light arm, but if mechanical work isn't your cup of tea, or you can't see well enough to do it yourself, perhaps a friend who is handy with tools can help. **Fig. 4** shows one such arrangement in a bit more detail, but the actual modification needed will most likely vary somewhat from one brand of bench light arm to another. You may have to be just a bit 'inventive' here.

"The little solid state TV cameras today generally don't require any additional lighting to produce a usable picture on a large-screen monitor, but if necessary, a small high-intensity desk lamp will probably provide enough extra boost in light level. Of course, the end idea is to electronically magnify very small objects (or printing), to a format much more large and bold for those of us with sight deficiencies. The little camera on the adjustable arm is so versatile that almost nothing is 'out of sight' for me anymore!"

Moderator's note: Great suggestion, Stan. This idea can open up a whole new world of enjoyment to those with a visual challenge ... if not yourself, perhaps a friend or neighbor might benefit from Stan's idea. But even if you don't have (or know someone with) small-detail vision problems, the basic idea can be put to work for you when you need to "surgically intervene" on some of today's ultra-miniature circuit boards! Operating room surgeons are using similar techniques to help

them to see what they're working on when delicate surgery is being performed, and we can all duplicate the concept (for a whole lot less money), with just a little time and innovation. If you opt to use one of the very small (and lightweight) CCD 8 mm camcorders on the market today, you can also videotape a complex disassembly procedure, so that putting everything back together again later will be made considerably easier. There's lots of room for individualization here!

A well grounded idea!

From Herb Foster AD4UA: "Here's a simple, inexpensive and easy-to-add-to suggestion for how you might be able to implement an effective, single point ground bus on the back of your amateur radio desk ... I've been using this method myself for some time now.

"Simply purchase a length of half-inch copper water pipe, as long as your operating desk is wide. Clean the length of pipe thoroughly, so that it looks nice and shiny. Kitchen cleansers, steel wool and fine sandpaper can all be enlisted to help with this part of the job! Now screw down the shiny pipe, with a husky screw and half-inch spacer, through each end of the pipe, to the back (top) surface of your operating desk. The spacer can be made of any material, even a couple of small chunks of the water pipe itself. The spacer's job is to hold the copper-water-pipe-ground-bus half an inch above the operating desk, so that you can then feed any number of one-inch stainless steel hose clamps around the pipe as the 'tap points' on the bus. All of your equipment ground wires will now go to the hose clamps and be rigidly clamped directly to the copper pipe, but can still be easily removed or relocated should the need arise. Of course a main station ground strap will also go from the copper pipe bus directly to your earth grounding

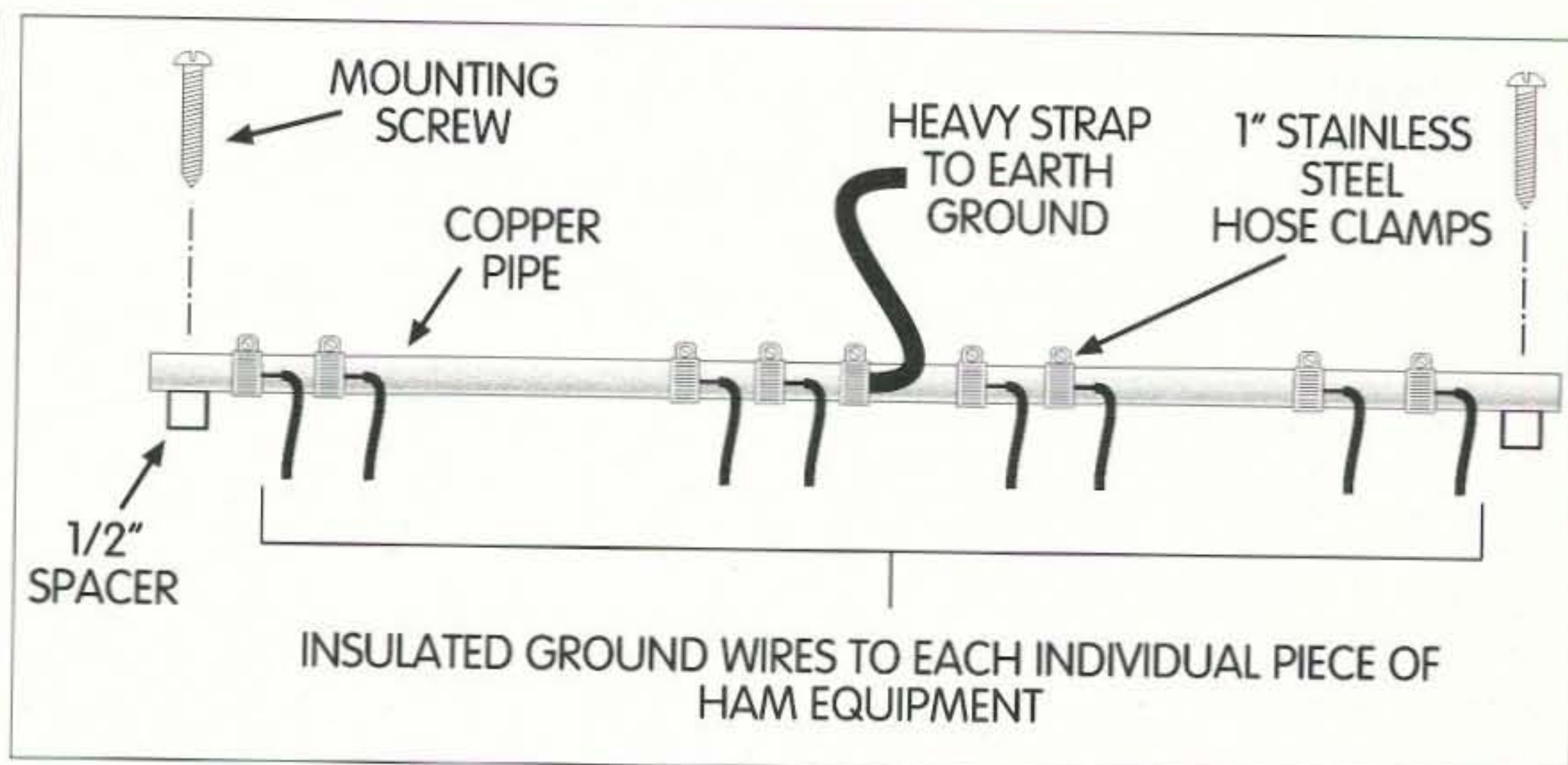

Fig. 5. AD4UA's easily-implemented ham operating desk ground bus.

system; Fig. 5 gives you an approximate idea of what the finished product will look like. You should be able to accommodate dozens of these small clamps on the ground pipe, so that your new operating desk ground bus will never be out of tap-off points."

Moderator's note: Nicely done, Herb. This is probably one of the easiest-to-accomplish ideas that I've seen for fulfilling the requirement of a solid, separate-wire earth ground for each piece of gear on your desk. Also, take another look at Fig. 3 as previously recommended by Roger and Ron Block.

Murphy's Corollary: Any transistor protected by a fast-acting fuse will blow out first, thereby protecting the fuse.

Many thanks as always to the contributors to this month's column, including:

Roger Block, President
PolyPhaser Corporation
2225 Park Place
P.O. Box 9000
Minden NV 89423-9000

Stan Strasburg W5TPS
1516 W. Magnolia St.
Rogers AR 72758

Herbert L. Foster AD4UA
3020 Pennsylvania St.
Melbourne FL 32904-9063
[ad4ua@juno.com]

If you're missing any past columns, you can probably find them at 73's "Ham To Ham" column home page (with special thanks to Mark Bohnhoff WB9UOM), on the World Wide Web, at: [http://www.rrsta.com/hth].

Note: The ideas and suggestions contributed to this column by its readers have not necessarily been tested by the column's moderator nor by the staff of 73 Magazine, and thus no guarantee of operational success is implied. Always use your own best judgment before modifying any electronic item

from the original equipment manufacturer's specifications. No responsibility is implied by the moderator or 73 Magazine for any equipment damage or malfunction resulting from information supplied in this column.

Please send any ideas that you would like to see included in this column to the moderator's address at top. We will make every attempt to respond to all legitimate ideas in a timely manner, but please send any specific questions, on any particular tip, to the originator of the idea, not to this column's moderator nor to 73 Magazine. 73

Radio Bookshop

Phone 800-274-7373 or 603-924-0058, FAX 603-924-8613, or see order form on page 88 for ordering information.

Wayne's Five Buck Books & Stuff:

Boilerplate. 45 of Wayne's ham oriented editorials. Great material for club newsletter editors who are always short of interesting items for filler.

Submarine Adventures. Wayne's WWII adventures on the USS Drum SS-228, now on display in Mobile, Alabama.

Wayne's Caribbean Adventures. Scuba diving and hamming all through the Caribbean. 11 islands in 21 days on one trip? You bet, and you can't beat the price either.

Wayne & Sherry's Travel Diaries. Cheapskate traveling to Russia, Europe, and so on. Now, how did Wayne and Sherry fly first class to Munich, drive to Vienna, Krakow, Prague, and back to Munich, staying at excellent hotels and eating up a storm, all for under \$1,000?

Cold Fusion Journal - Issue #20. Read the latest scoop on cold fusion in this whopping 92-page sample issue. Cold fusion dead? No way!

One-Hour CW Course. How anyone can pass the 5 wpm code test with less than one hour of study. This also explains the simplest system for learning the code at 13- and 20-per ever discovered. Or, do it the old fashioned (ARRL) hard way and suffer. Your choice.

Other, Slightly More Expensive Stuff:

Pure Silver Wire for making those miracle silver colloids. Two 3" lengths of #10 99.999 pure silver wire \$15. Should last for years.

Bioelectrifier Handbook. Background, circuits, uses, etc. \$10.

Adventures in Regulation

How to use a fixed voltage regulator in a variable application.

Hugh Wells W6WTU
1411 18th St.
Manhattan Beach CA 90266-4025

Here you are, right in the middle of building a project and—what happened to the variable voltage regulator that was in the junk box? Never fear! Making a variable voltage regulator out of a fixed regulator is very easy, and it will substitute for an LM317 in many applications.

Most any fixed voltage regulator can be made to operate in a variable voltage application, but with some limitations. The limitations involve the voltage range and the method used for voltage control. The voltage range will be from the regulator's output voltage value up to approximately 35 volts. Should a 12 V regulator be used, as an example, the regulated output voltage would be controllable from 12–30 volts. The actual upper value will be limited by the headroom value, typically 5 V, which is the minimum voltage differential between the input and output of the regulator required to keep the regulator active.

If the full variable voltage range is not required in the application, it is best to reduce the input voltage to the regulator or raise the regulator's output voltage in order to reduce the device's heat dissipation. If a 15–20 V

regulated output is desired, a 12 V regulator is suggested as a better choice than a 5 V device. A 5 V regulator would be the preferred choice if the output were to be between 5 V and 12 V, but the supply voltage should be kept low, perhaps in the 15–20 V range, to keep down the regulator's heat dissipation. In other words, a 24–37 V source should not be used when only a regulated output below 12 V is needed.

Let's examine a fixed voltage three-lead regulator of the 7805 or LM340-5 type (**Fig. 1**). Having three leads, there is one for the input and one for the output. The third lead is a common reference for both the input and output. The common reference lead is also the tab of a TO-220 device. For the five-volt regulator, the voltage between the output terminal and the reference terminal is maintained at five volts for any load current from zero to 1.5 amps. The same theory is true for devices having a different output voltage.

For regulators to operate properly, their internal amplifier gain must be very high. Although the high gain is desirable, the amplifier gain-bandwidth can cause some serious problems if not

kept under control. What this means is that the high gain is desirable at very low frequencies, and undesirable at higher frequencies where the high frequency gain can allow the regulator to oscillate. Bypass capacitors are used across the input and output terminals to reduce the regulator's tendency to oscillate. Although the capacitor values aren't critical, they should be in the range of 0.01–0.1 μ F and the lead lengths kept short. Disc ceramic capacitors work well in this application. With the bypass capacitors in place, the gain-bandwidth is reduced sufficiently to stop oscillation. However, the low frequency gain remains high, where it is needed to react against output voltage changes.

Adjustable voltage output

There are occasions when the fixed regulator does not provide the exact or desired voltage for a particular application and it would be nice if the output were adjustable. One of the most common ways of raising the output voltage of a three-lead regulator is to place one or more forward-biased diodes or a zener in series with the common reference lead of the regulator (**Fig. 2**). The

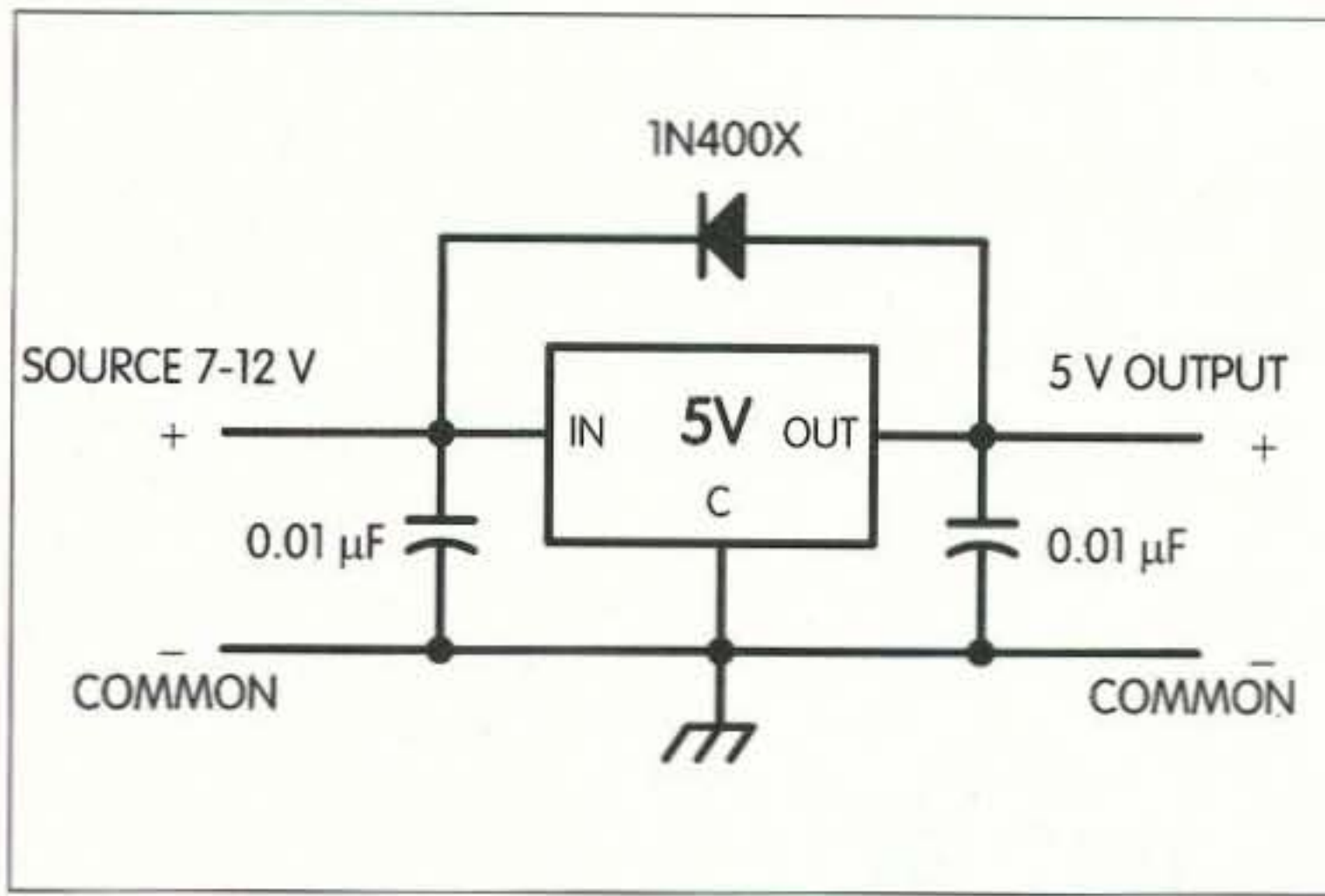

Fig. 1. Fixed voltage regulator using either a 7805 or LM340-5 device.

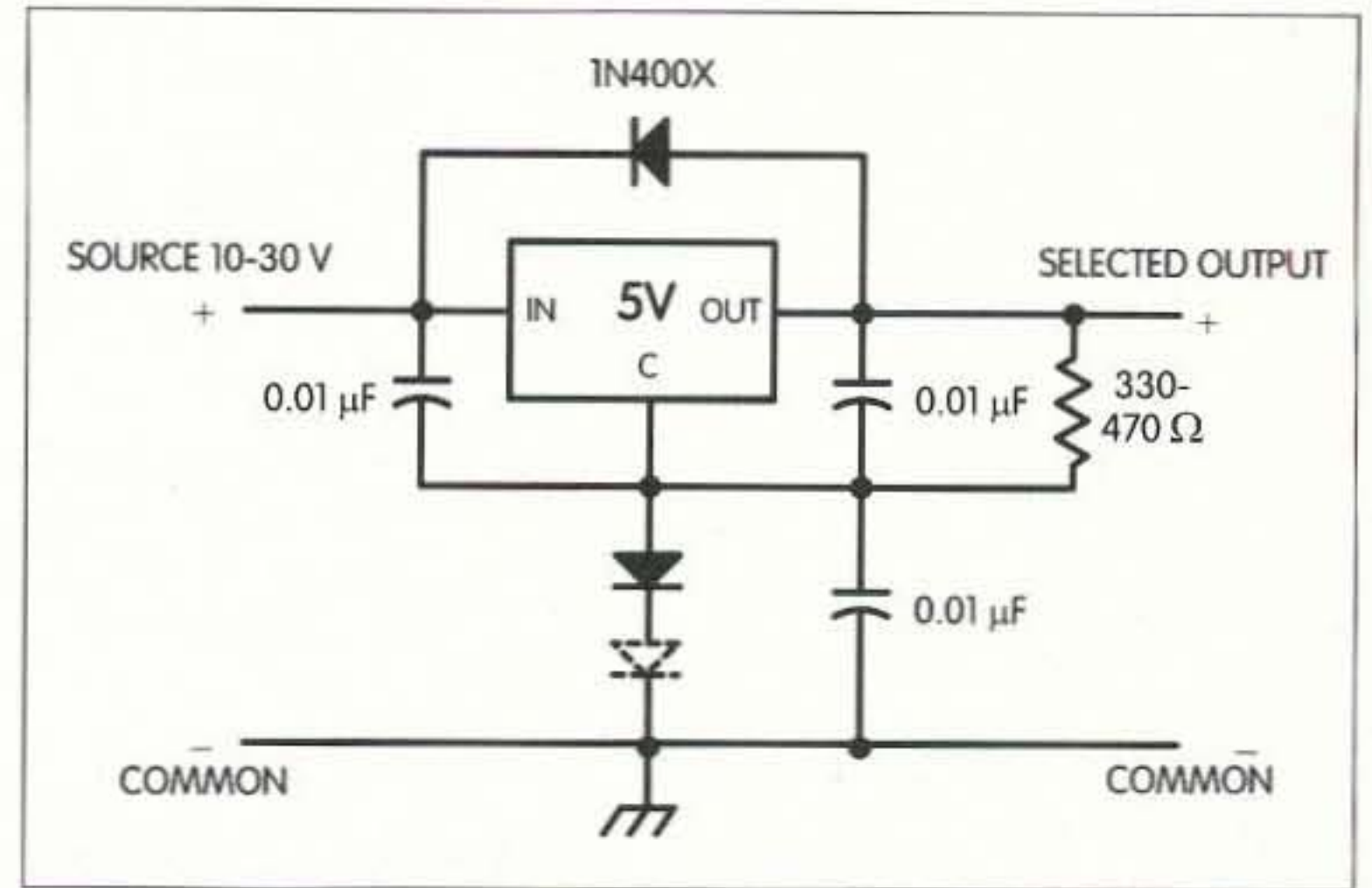

Fig. 2. Fixed voltage regulator with the output voltage selected/adjusted using forward-biased diodes.

output voltage is raised by the value dropped across the diode(s). This technique is suitable for selecting a fixed or stepped voltage value above the regulator's normal output value. The output voltage obtained will be the regulator's output voltage plus approximately 0.7 V for each diode added to the stack. Most any diode will work well in this application, with typical ones being the 1N4148 and the 1N400X (series). The 1N400X series diode is usually the diode of choice because a high forward current tends to stabilize the forward voltage drop across the diode.

To make a variable voltage regulator out of the fixed regulator, it is necessary only to vary the voltage between the common reference lead and

the circuit's common point. The current in the common lead of a typical 7805 regulator is 5.5 mA, and this value tends to remain constant regardless of load current. Placing a low-resistance potentiometer between the common lead and ground will provide a means for varying the output voltage (Fig. 3). The output voltage will rise by the amount dropped across the pot, as is the case when a diode is used. To vary the output voltage from 5-30 V, the potentiometer resistance must be varied from zero to about 1 k ohms, with a pull-up resistor of 330-470 ohms to the output as shown.

Although more complex than the circuit shown in Fig. 3, an NPN transistor may be used as a variable resistor between the common reference

lead and ground (Fig. 4). The idea behind using a transistor as a variable resistor is that transistors are more capable of dissipating heat over the entire control range and will provide a smooth control of the output voltage. The voltage drop is quite stable, which makes it the method of choice. Also, the use of the transistor versus the potentiometer method provides some additional loop gain and, if desired, remote sensing for the output voltage at the load which helps regulate the voltage at the load circuit. Several transistor types, such as a 2N2222 and TIP29 with TO-92 and TO-220 case styles respectively, have been used in this application and work well because

Continued on page 84

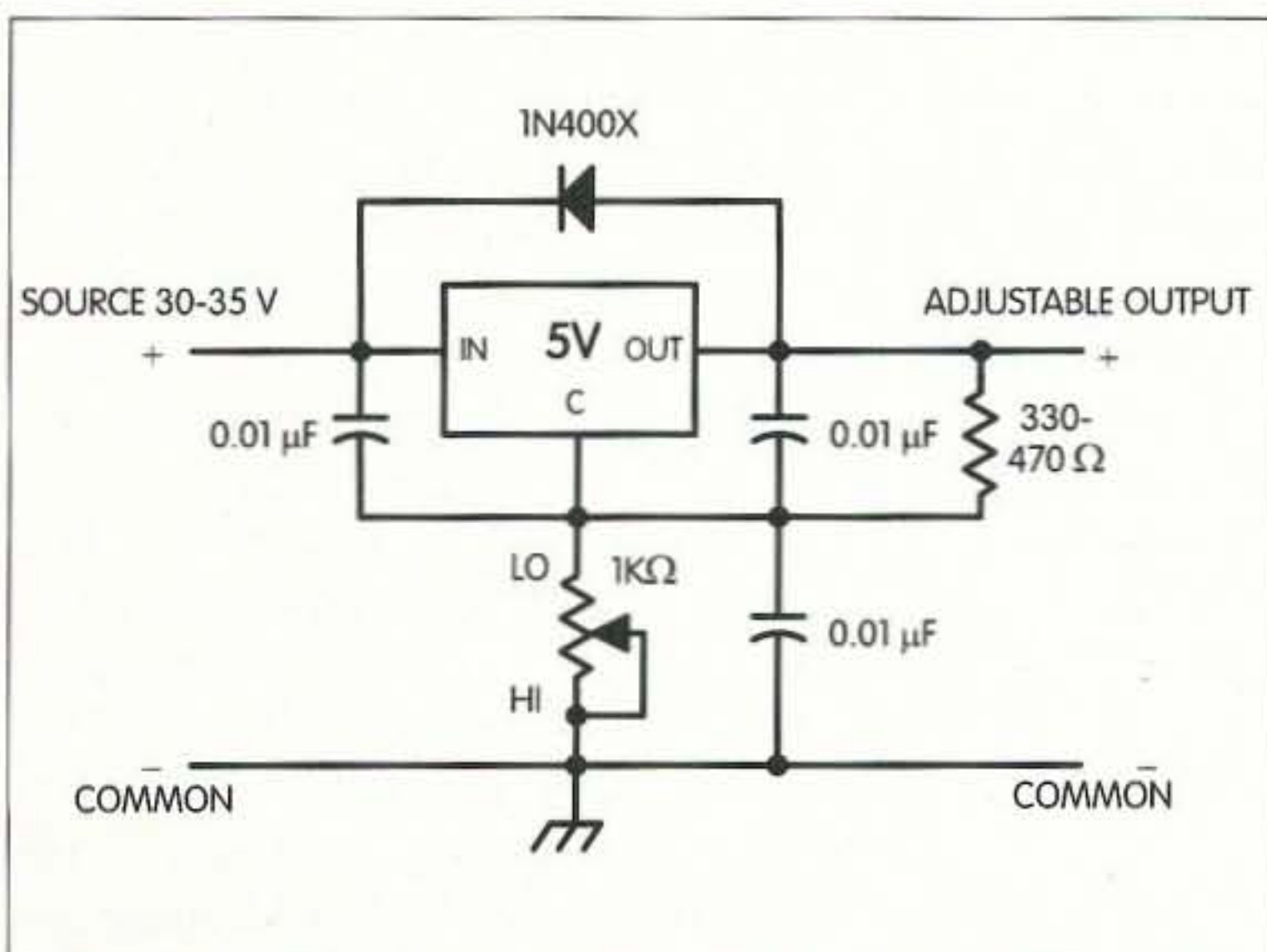

Fig. 3. Variable voltage output using direct potentiometer control. A regulated output from 5 V to approximately 30 V is obtainable.

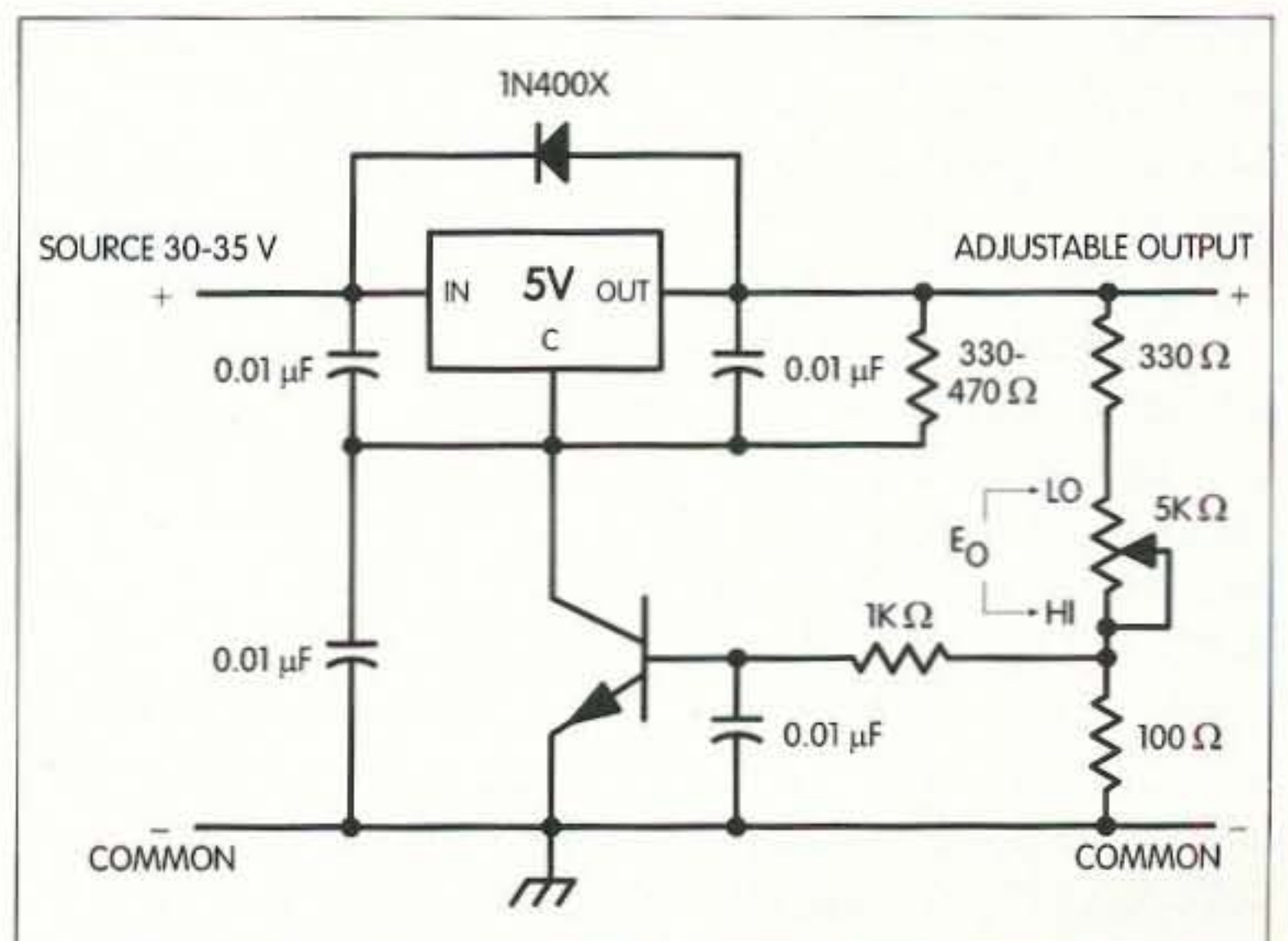

Fig. 4. Variable voltage out control using a transistor. Remote output voltage sensing is available. A regulated output voltage is available from approximately 5-30 V.

How About A Kinky-Interesting-Sexy-Sexy?

A scary trip — one way, thankfully — down phonetics lane.

Dr. Trevor M. Artingstoll GØJOE
1 Whitefriars
High Street
Cambridge CB4 1NN
England, UK

Sitting here in the shack, supping tea, twiddling knobs, listening to the 20-meter contest, one thing is growing abundantly clear: The International Phonetic Alphabet is being misused more often than not. And all nationals are responsible.

Misused? How can extra letters tacked on a letter of the alphabet enabling it to be sounded as a word possibly be misused? A for Ape, A for Algernon—A for Antidisestablishmentarianism. So what? They all begin with A, and that's the one letter we are interested in putting over to the guy on the hot end of the antenna.

Yes, and ... er, no. Many, too many, hams believe that something audible—almost anything coming to mind, in fact, tacked onto a letter of the alphabet can make it a significant sound, a phoneme. Listen on 20 meters any night and you'll get my drift.

Why bother with the dull "Alpha" when "America" does as well? Yodeling, "How about a Kinky-Interesting-Sexy-Sexy?" pries apart the QRM, and surely does a good job of fixing the attention of that YL in Canton, whereas muttering the official "How about a

Kilo-India-Sierra-Sierra?" sounds as if the office geek is inviting the Butterfly Princess to afternoon tea and cucumber sandwiches.

This relaxed approach, one so widespread it is planetary, possibly came from a misunderstanding. When many hams think about the matter at all, they believe that the phonetic alphabet, like Topsy, "just grewed." It is true that Apples, Butter, and Charley of the 1914–1918 Flanders trenches came from a time in history when Britain was arbitrarily ruling most of the world, so why not boss the frequencies? After all, we invented radio—with an insignificant bit of help from the Eytie chappie, Signor Wotsisname—it'll come to me in a minute ...

You can almost hear the dialogue in that 1915 dugout in Flanders as the phonetic alphabet developed:

"I say, sir, what shall we call the jolly old letter 'A'?"

"Apples, of course, Lieutenant Chuffchuff."

"And 'F', sir?"

"Freddy, Lieutenant Chuffchuff, definitely. After my brother. Rides with the Pytchely, y' know? Damn fine seat."

Since the privately schooled officer-caste of the British forces is more inbred than an Appalachian mountain town, or so I hear, in 1917 the Royal Navy eventually pressed all the service into using its version: Apples, Butter, Charlie, Duff, Edward, Freddy, George, Harry, Ink, Johnnie, King, London, Monkey, Nuts, Orange, Pudding, Queenie, Robert, Sugar, Tommy, Uncle, Vinegar, William, Xerxes, Yellow, Zebra.

"Duff" (think of sourdough with sugar and raisins) and "pudding" got there undoubtedly because sex was kicked out of them with rugby and cold showers, so comforting eating was in. At Rugby, "Edward" was the aide of the commissioning officer—they were very, very close; Edward would do anything for a dare. "Monkey" wittily followed by "Nuts" laid them flat in the wardrooms and officers' messes of His Majesty's military. "Xerxes" showed they had studied the classics even if they hadn't understood them. "Ink" was sheer nostalgia for the times they flicked blobs of it at one another during prep.

The immortal F.J. Camm, editor of *Practical Wireless* and whose books

are now collectors' items, tried in 1946 to internationalize what seemed a set of class attitudes. Perhaps military service abroad had made him realize that the occasional Italian and Spanish operators were out there, too.

In *Newnes Short-wave Manual*, he came up with: Amsterdam, Baltimore, Casablanca, Denmark, Edison, Florida, Gallipoli, Havana, Jerusalem, Liverpool, Madagascar, New York (Oh, can't you just imagine the chaos after "New what?"), Oslo, Paris, Quebec, Roma, Santiago, Tripoli, Uppsala (There's no such place, surely?), Valencia ("B' for *Balenthia*, señor? We pronounce 'V' as 'B' in Spain!"), Washington, Xanthippe ("No, I do not mean 'boz,' muttonhead—'Zanteepee' is how you say it, but it looks 'X'—'box' damn it, b-o-x, I spell Baltimore—Aw, what the hell!"), Yokohama, Zurich.

Camm may have been the first to make many peacetime English aware that the jungle doesn't begin just past the low-water mark. Begins at Calais ...

About this same time, the Royal Navy began getting its act a little more together, feeling its way toward a scientific system of phonetics. Eventually it came up with: Able, Baker, Charlie, Dog, Easy, Fox, George, How, Item, Jig, King, Love, Mike, Nan, Oboe, Peter, Queen, Roger, Sugar, Tare, Uncle, Victor, William, X-ray, Yoke, Zebra.

Things took a backward step in 1963—well, in ham radio they did, and only for a time. Fancy phonetics not being the preserve of the Brits alone, in *Understanding Amateur Radio* (1963) George Grammar, Technical Director of the ARRL, weighed in with West Point severity: "Most of the time, amateur operators use some sort of phonetics—some of these are 'cute,' some have no business being used on the air, and some serve the purpose of aiding in the identification of your call letters (when) interference may be heavy.

The ARRL has adopted such a phonetic alphabet, as follows." And he went on to list: Adam, Baker, Charlie, David, Edward, Frank, George, Henry, Ida, John, King, Mary, Lewis, Nancy, Otto, Peter, Queen, Robert, Susan, Thomas, Union, Victor, William, X-ray, Young, Zebra.

Yessir! Will history ever tell us who the ARRL Mr. Quiverful was with such a big family? And why was poor little "Union" sacked from his very first job in Little Rock? But "Xanthippe" is no more, did I hear? You really think so? Please read on.

George Grammar, in the turmoil of the time, had taken his backward step through not having come across a book written a decade earlier. With the uncanny prescience certain writers can show, Robert Hertzberg K4JBI had published *So You Want To Be a Ham?* in 1955. In it, he remarked that the FCC had not prescribed an official phonetic alphabet, "which amateur radio sorely needs." He went on to say that the most generally used form was one growing out of a United States-British military agreement. This turns out to be the Royal Navy alphabet above: Able, Baker, etc.

"More recently," he goes on, "a new international alphabet was adopted by the military services and commercial airlines." Hertzberg notes that this new form has multi-syllabic words with the stress coming naturally on the first. The words of the older form are practically unstressable, he notes further. Remember plucky little "X-ray" hanging in there?

The British used "R" for All Received Correctly in CW, but the Americans wanted to use "OK." They abandoned this, Hertzberg claims, as part of the same military agreement. Phone was being used more often than CW and it seems the Brits regarded "OK" as far too flippant to be used in our tightly disciplined armies.

So "Roger" was born, and quite rightly, too. Even so much as thinking "OK" in the presence of five feet of red-tabbed-uniformed aristocratic mediaeval over-privileged gives me the cold shudders.

But from Hertzberg's book it is clear that science had entered the world of the international phonetic alphabet. Multi-syllabic words with stresses naturally on the first is a quantum leap from "Ink." Science was coming to the rescue.

Was a rescue needed? If'n it ain't broke, why fix it? To answer this important question, I must move away

from the topic a little. Toward the end of the twentieth century, as we all know, some cowboy contractor from Sirius 5 began remodeling Earth into the Global Village. Now, nation really does speak unto nation; nightly, Inuit operators fade into the QRM, being replaced by Sioux whizkids working Madagascar five and nine with Fiji on the side—come in, Arran! We are becoming villagers, all living on one whirling space-born hamlet, Planet Earth.

This internationalizing (and democratizing) of the ionosphere matters zilch to the average WASP ham, of course. Fondly imagining English is the master language of amateur radio, we tune up nightly, happy inside our cultural bubble with its drawn curtains. Few of us realize that English is often being politely spoken for our benefit by polyglots aching to chew the rag maybe in Basque or Farsi as soon as we go QRT.

Zilch to us, but the need for effective communication is wider than mere hobbies or even national frontiers. International industries such as airlines can literally live or die by effective phonetics.

Imagine, for example, this scene from my latest interminable catastrophe film, Airfield Destiny, starring Slagbag O'Hara:

It is night. Thick fog, an Army smoke screen laid by accident across the airfield, and a power blackout are making conditions rather difficult.

"You're landing too far down the runway. Brake, for God's sake, Flight 1003!"

"Er, what-a you say, control tower? No 'ear you too good."

"Brake, Flight 1003! Please, for Pete's sake! You're coming right at us. Baltimore - Rome -"

"No want-a Baltimore - Rome, why you say Rome - ees Roma - no want-a Rome - want-a Boston. This-a Boston, capice?"

There is the sound of something splatting. Yet another control tower bites the dust. OK, OK, so the director drank.

They called it pilot error, when in fact it was phonetic error. It's such a

PHONETIC RADIO LANGUAGE

	ENGLISH	GERMAN	FRENCH	ITALIAN	SPANISH	PORTUGUESE
A	Alpha	Anton	Alfa	Alfa	Alfa	Antena
B	Bravo	Berta	Bravo	Bravo	Brasil	Bateria
C	Charlie	Casar	Charlie	Canada	Canada	Condensador
D	Delta	Dora	Delta	Delta	Delta	Detector
E	Echo	Emil	Echo	Europa	Espana	Estatico
F	Foxtrot	Friedrich	Foxtrot	Firenze	Francia	Filamento
G	Golf	Gustav	Golf	Guatemala	Guatemala	Grade
H	Hotel	Heinrich	Hotel	Hotel	Hotel	Hotel
I	India	Ida	India	Italia	Italia	Intensidade
J	Juliet	Julius	Juliett	Juventus	Japon	Juliete
K	Kilo	Konrad	Kilo	Kilometro	Kilo	Kilo
L	Lima	Ludwig	Lima	Lima	Lima	Lampada
M	Mike	Martha	Mike	Messico	Mejico	Manipulador
N	November	Nordpol	November	Novembre	Noviembre	Negativo
O	Oscar	Otto	Oscar	Otranto	Oscar	Onda
P	Papa	Paula	Papa	Palermo	Papa	Placa
Q	Quebec	Quelle	Quebec	Quebec	Quito	Quadro
R	Romeo	Richard	Romeo	Romeo	Radio	Radio
S	Sierra	Siegfried	Sierra	Santiago	Santiago	Sintonia
T	Tango	Theodor	Tango	Tango	Tango	Terra
U	Uniform	Ulrich	Uniform	Universita	Universidad	Unidade
V	Victor	Viktor	Victor	Venezia	Victor	Valvula
W	Whisky	Wilhelm	Whiskey	Whisky	Whisky	Watt
X	X-ray	Xanthippe	X-ray	Xilofono	Xilofono	Xilofono
Y	Yankee	Ypsilon	Yankee	Yokohama	Yucatan	Yucatan
Z	Zulu	Zeppelin	Zulu	Zelanda	Zulu	Zulu

Table 1. List of international phonetics.

dated mistake. I recall a schoolboy joke of the maid on the telephone spelling London "L for Lulu," and a voice at the other end asking, "L for what?" The pilot similarly was caught up in analyzing the meaning of the phonetic words when what they meant was irrelevant to the initial letter each was carrying.

"Sierra" can do that to me still. I took a camping trip in the Spanish Sierras years ago with this very active girl ... very. "Sorry. Please repeat all after 'Sierra', OM."

The saga has a happy outcome. By 1975, the planet was on track with our

tried and true buddies, Alpha, Bravo, and the rest of the gang. (See Table 1.) And this gang almost satisfies the four requirements whose absence the air-field scenario is intended to illustrate.

The first requirement is to make the alphabet politically correct. The various radio organizations of the world are refusing just any old bundle of phonemes these days. If Lebanon has been invaded by Marines again do not expect a happy reaction when using "America" to spell out your callsign for a patriotic ham in Beirut. Sending "Afghanistan" up 30,000 feet to an

Ilyushin airliner during a tense moment over Washington could cause grief, too. "Waterloo" is never acceptable to French ops. Give you one guess!

Doubtless readers can think up their own lists of unacceptable phonemes. They called me "Four-eyes" at school. Just try me with "F for 'Four-eyes'" and see what happens to our QSO!

The second requirement is that the words must be international, or as international as possible, Old Norse, Sinhala, and Erse being what they are. Hams all over the planet must be given a chance of recognizing at least some of the words immediately as being from their own languages, making the alphabet easier to learn and more acceptable.

The existing alphabet goes a long way to doing this. Alpha and Delta are Greek; Sierra is Spanish; Yankee (Yanqui) is Red Indian.

Words not native to a language still have a good chance of being recognized, remembered, because they have international currency; Foxtrot, Hotel, Golf, India, Zulu.

Poor Topsy doesn't get a look in nowadays—internationally used phonemes are too important just to be allowed to grow.

Which brings me to the third, very important, requirement: aural standardization. Phwah! I can't believe I said that, but nothing else will do. It was hearing this standard breached so often which got me researching this article.

When communicationally challenged members of the human race take to the airwaves and the QRM is thick enough to stand on, Pablo, QTH Madrid, and Stanislav, QTH Minsk, can both write down "S" when each hears only "Ee-erra" or even "Erra" instead of the full "Sierra". If, however, aural standardization is disregarded and Stanislav launches "Stalin" at Pablo and "In-" alone gets through the electric soup, where does it leave the poor onion-eater? No informed guessing is possible. And if "Lin" is something unmentionable in Spanish, it could cause an incident, or even an Incident! Spaniards are a proud people!

The fourth requirement is satisfied if we follow the stipulation of the

prescient Hertzberg that phonemes should be multi-syllabic with the stress on the first syllable.

Imagine loose-mouthed GØJOE trying to insult someone over the air, call him an idiot, say. The other guy is hitching through Rwanda which in itself is a good reason to call him an idiot, but he simply can't be insulted because of wall-to-wall QRM.

"Did y'all say 'hot', GØJOE? Sure as hell is."

He has only received the last syllable of "idiot." So off I start with a pre-1917 monosyllabic phoneme, "Ink."

"Y'all got some hassle with your mike theah, GØJOE? C'n hear a squeakin' like one o' them pesky field mice back home in Tinnasee."

Stupid old me; stupid old idiot, come to think of it. If the three-syllable word "idiot" has not got through, maybe allowing him to hang onto one of the syllables and try guessing the other two, what chance does a single syllable have?

Thus, not only must a phonetic word be internationally acceptable, familiar to all users, and aurally standardized, it must have more than one syllable—preferably no more than three.

Now enter the modern International Phonetic Alphabet! The words of this little darling have not just growed, they have been hand-picked!

Table 1 shows that the English and the Americans are using it. Even the French. The Germans? I don't believe it! "Xanthippe" is taking longer to die than Olivier in *Brideshead Revisited*!

Italy and Spain have a long, long way to go. "It's in the box, signor. Box! I spell 'Brazil - Oscar - X' — now what in tarnation are they using for 'X'? 'Eksilofono'—what the hell sort of a word is that? 'Zilofono', did you say, precious heart? No, that will be for 'Z'."

But "our" Franco-WASP phonetic alphabet obeys the four requirements listed above:

1. It comprises only politically correct words—excuse?

"Waal, son, down heah in Alabama that there 'Y' fer 'Yankee' ain't the best-sounding word we ever knowed."

2. Each word should appear in as many languages as possible.

3. We must use these words and no others.

4. Each word must be of more than one syllable. "Mike"? "Golf"?

One thing seems clear. If this burgeoning problem is not snuffed out quickly and firmly, I foresee growing anarchy, with personalized phonetic suffixes taking off until the entire phonetic alphabet becomes split between individuals as it is now to a certain extent between nations (see **Table 1**).

To put this vitally important alphabet back on single frequency perhaps *73 Amateur Radio Today* might consider organizing an International Phonetic Alphabet Day? Twenty-four hours could be set aside each year, during which every sexy misuse on SSB, two meters, and 70 cm can be politely, gently identified, and the correct, lusterless, boring usage given in place of it. Lives could be saved.

Politely, I stress. Ideally, QSOs beginning, "Listen, cow brain!" should rarely, if ever, take place. And be gentle! Kickings must be kept to an absolute minimum. We do not want torrid incidents of Radio Rage fenestrating eardrums, filling the hospitals

Maybe on Signor ... er ... Wotsisname's birthday? The Eytie chappie? It'll come to me in a moment, Lieutenant Chuffchuff. Bear with me

My thanks to the Radio Society of Great Britain for giving me the use of its legendary library in Lambda House, and special appreciation to librarian John Crabbe G3WFN. His graciously proffered cups of coffee, as well as

yarns and indications of likely books to advance my research, made my visit pleasantly memorable. 73

208-852-0830
<http://www.rossdist.com>

SPECIAL!
Under \$1225.00

KENWOOD TS-570D
All Mode HF Transceiver

RDC

Check Out Our Specials! We're On The Web.
Over 9050 HAM Items In Stock. All Prices Cash FOB Preston
ROSS DISTRIBUTING, 78 S. State Street, Preston, ID 83263
Hours Tue.-Fri. 9-6 • 9-2 Mondays. Closed Saturday & Sunday

CIRCLE 254 ON READER SERVICE CARD

BIOELECTRIFIER

PLANT GROWTH STIMULATOR

- COMPACT SIZE, 4.5" X 2.25" X 1"
- ADJUSTABLE OUTPUT UP TO 25 VOLTS
- STAINLESS STEEL ELECTRODES
- WIRED AND TESTED

FOR MORE INFORMATION
SEND SASE TO:

SEAGON COMPANY
5541 OAKVILLE CENTER
SUITE 215
ST. LOUIS, MO 63129

CIRCLE 241 ON READER SERVICE CARD

Weather Satellite Imagery

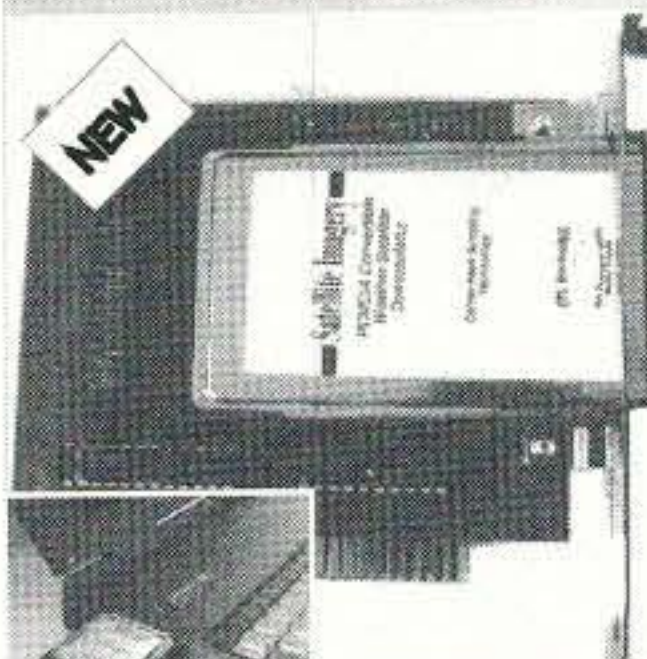

OFS WeatherFAX, Phone/Fax: (919) 847-4545
6404 Lakereed Court, Raleigh, NC 27612 E-Mail: jdahl@worldnet.att.net

PCMCIA Convertible Capture Board

- Low power - PCMCIA type II
- Use on your Laptop and Desktop

HF Marine, NOAA polar satellites, GOES satellites
Perfect for boat, vehicle, plane, or home

Full Function Software

- DOS and Windows
- Sea surface temperatures
- Coastline and Lat/Lon grids
- GOES animation
- Decodes WEFAX headers

The Best in PC based Weather Satellite Imagery

OFS WeatherFAX
High Performance Satellite Weather Facsimile

The Kelowna Kactus Home-Brew Antenna

And we mean home-brew!

Ron Brillinger VE7RFB
358 - 550 Yates Rd.
Kelowna BC V1V 1Z4
Canada

Here is the description of a two-meter antenna you won't find in *The ARRL Antenna Handbook*. I needed a high efficiency antenna for my attic, since the subdivision into which we had just moved had legislated complete prohibition of antennas.

This would be a vertically polarized antenna, exhibiting low-angle radiation and fitting into the 10-foot height of my attic. I would use copper pipe to fabricate the antenna and its phasing sections, because I wanted to keep I²R losses very minimal.

Figuring that I could accommodate two half-wave sections, one above the other, in the space available, some kind of vertical collinear design seemed in order. I wanted to feed the antenna with coaxial cable at the bottom.

The arrangement for my Kelowna Kactus I finally decided upon was a sort of double extended dipole with a J-section feed. Dimensions are shown in **Fig. 1**. As I said, I wanted to keep losses to a minimum, so I silver-soldered the pieces of copper pipe together and used plastic end caps to

keep out moisture. After assembly, I mounted the antenna in the attic and fed the coax down to my radio.

Improvements (?)

The antenna seemed to work well enough, but I got to thinking that it might have a lower angle of radiation and work better if I could equalize the antenna current in both of the half-wave sections above the J-section. *The ARRL Antenna Manual* suggests that bending a portion of a matching section in the direction of the radiator closest to the feedpoint could help to equalize currents in the antenna sections, so I "re-engineered" the phasing section in the middle of the antenna to give it a slight droop, about seven degrees downward at the outer end.

Being a little concerned about condensation in this downward sloping section, I drilled a 3/16-inch hole at the bottom for drainage.

Further testing showed that the angle of radiation from this omnidirectional antenna was in fact very low. My two-meter signal was getting out!

Things heat up

It was during one of my many trips to the attic to prune the antenna for best SWR at 146.940 MHz that I noticed that the bottom 18 inches or so of the J-section (down where the coax input cable was connected) was getting really warm. You might even say *hot!*

I found a small oven thermometer and taped it to the copper pipe near the bottom of the J to see just how hot it was getting. The temperature was reaching upward of 172 degrees Fahrenheit after each short transmission!

Heat equates to losses, so clearly something had to be done to lower the temperature in the copper pipe. I decided to fill the pipe with a cooling liquid.

My first thought was to use distilled water to fill the lower section of the copper pipe, but I was concerned that the attic might get cold enough in our Canadian winter to freeze the water, causing expansion that would crack the pipe.

I thought of dissolving salt with the water to lower its freezing tempera-

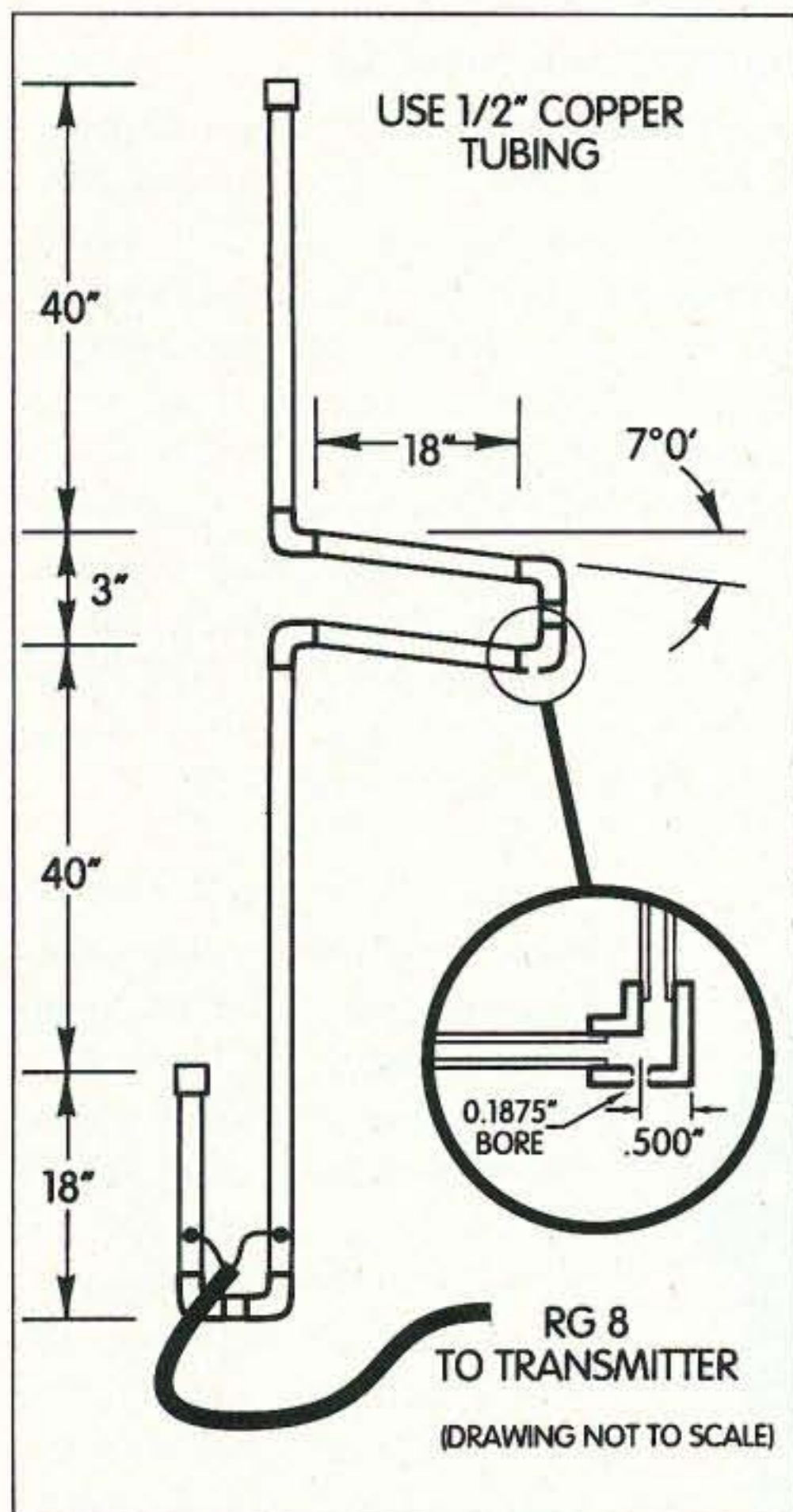

Fig. 1. The Kelowna Kactus two-meter antenna.

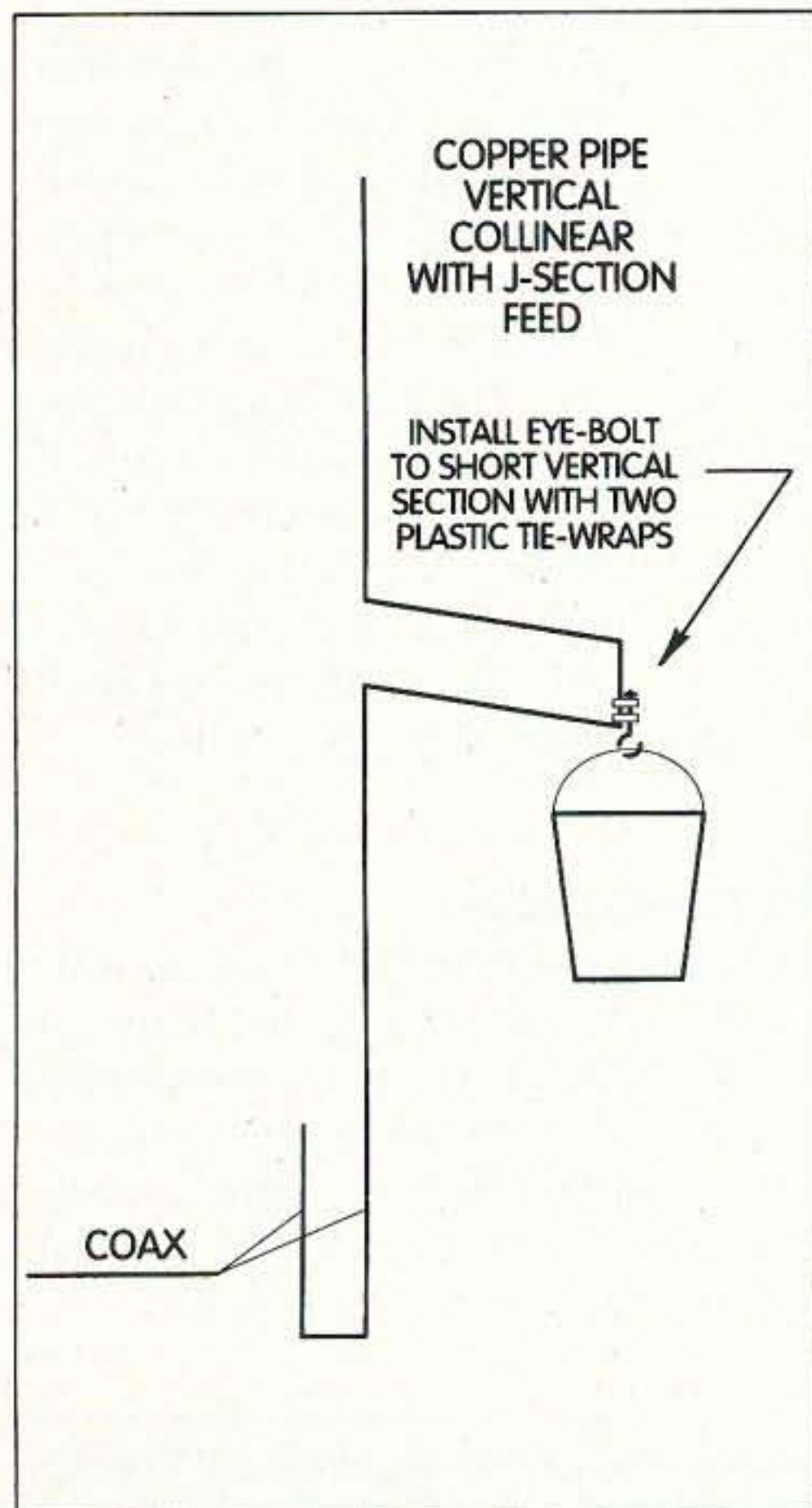

Fig. 2. Installation of the plastic bucket. A small eye-bolt is attached to facilitate bucket removal.

ture, but the idea of salt coming in contact with the copper and causing corrosion made me discount that idea.

Sweet solution

My wife Margaret was in the kitchen making bread when I took leave from testing for lunch, and I happened to observe that she was mixing flour, yeast, and sugar. Yes, sugar!

This gave me the inspiration to liberate some from the kitchen counter and add it to the cooling water in my antenna. I mixed up enough of this anti-freeze solution to fill up the J-section at the bottom of my copper-pipe antenna.

I then reinstalled the plastic caps on each end of the pipe to prevent evaporation.

Further testing of the antenna over the next few weeks showed that it was performing, but the lower J-section continued to get quite hot during each transmission. Hot enough, in fact, that steam could now be seen pouring out of the 3/16-inch hole drilled at the bottom of the matching section.

And furthermore ... the steam had a peculiar odor! A drop of funny-smelling liquid gradually collected on the end of the matching section. I touched my finger to it and cautiously tasted. Hmm ... *Could it be? It sure tastes like ...*

So I suspended a small bucket below the drip hole as shown in Fig. 2, to collect more of this nectar ... and after an hour or so of calling CQ, I had collected about two ounces of ... *tequila!*

Does my Kelowna Kactus antenna work as well as expected? Well, no—it doesn't—but who cares? I've no problem with the necessary continual operation and testing. CQ ... CQ ... CQ ... CQ

P.S. Continued research is now underway on a 10-meter, 10-ounce per hour version of this antenna, as well as a 12-element vertically stacked two-meter version complete with 10 drooping sections and buckets.

Depending on the mixture rate of research input and test antenna output, results may or may not be available by April 1st next year.

ELECTRONIC COMPONENTS

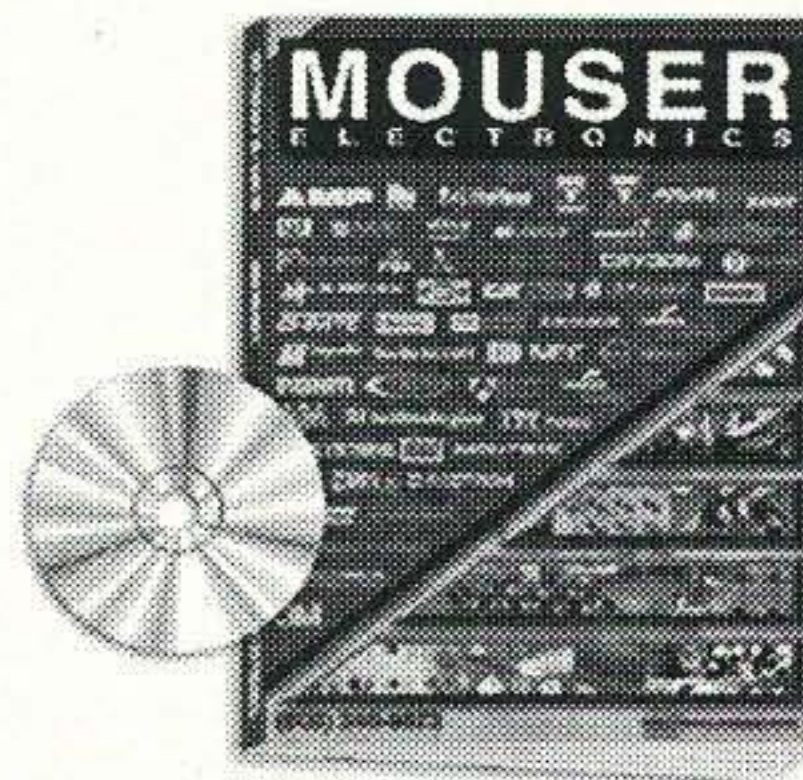

Visit our web site!
www.mouser.com

FREE catalog is available on the internet, CD-ROM, or in paper!

- 70,000+ Products • 145 Suppliers
- Same Day Shipping • No Minimum Order

800-992-9943

817-483-6828 Fax: 817-483-0931
www.mouser.com catalog@mouser.com

958 North Main St., Mansfield, TX 76063

CIRCLE 64 ON READER SERVICE CARD

VIDEO-TRANSMITTERS SMALLEST IN THE WORLD

AMAZING VIDEO-TRANSMITTERS!

- 900 MHz Crystal controlled, range 300-600 feet, 10 mW, from 119 \$
 - Size only 0.8" X 0.4" AM or FM modulation, IDEAL FOR SECURITY!
 - High quality B&W or Color picture, PAL or NTSC SYSTEM.
 - Long range units are available upon request, no audio!
 - SMALLEST IN THE WORLD TRANSMITTER CH 59- 433 MHz- 99 \$
 - RECEIVERS FOR 900 MHz for AM or FM, TUNABLE, from 149 \$
 - PANEL ANTENNAS 10dB GAIN, 900 MHz, from 69 \$
 - NEW!!! MMDS DOWNCONVERTERS 2.5-2.7GHz, with antenna- 199 \$
 - VIDEO-TRANSMITTERS 2.4 GHz, size 0.8"X 0.6" FM modulation!
 - MAKE YOUR OWN TV STATION:
 - TV UHF TRANSMITTERS-EXCITERS, PLL, FOR EXPORT ONLY!
 - LINEAR AMPLIFIERS UHF for TV EXCITERS, High Quality Units!
 - Wideband 470- 900 MHz, 1- 10 W Output power, only 2 mW Input!
 - HIGH GAIN TV ANTENNAS FOR TRANSMITTERS, FILTERS...
- PLEASE SEND 2 \$ FOR A CATALOG, DISCOUNTS FOR QUANTITY, FREE SAMPLES!
SOME RESTRICTIONS MAY APPLY!



VOSTEK ELECTRONICS
P.O. BOX 60043,
1052 PAPE AVE.
M4K 3Z3, TORONTO, ONT.
FAX/PHONE 416 423-7024
E-MAIL: vostek@globality.com

CIRCLE 182 ON READER SERVICE CARD

Back Issues

of

73 *Amateur Radio Today*

Only \$5.00 each

Call 800-274-7373

NEW PRODUCTS



HOW DO YOU STOP A NICD FROM (OVER-) CHARGING?

MFJ Enterprises, Inc., is proud to announce the new MFJ-641 RapidBattery™ universal charger. It'll do both quick- and trickle-charging and will charge NiCd or NiMH battery packs. Charging status LEDs let you know when your battery is fully charged and microprocessor charging control technology stops the charg-

ing circuit when fully charged, avoiding overcharging and prolonging the life of your battery.

The palm-sized MFJ-641 uses universal interchangeable charging slots for drop-in charging. It comes with your choice of one charger slot; you buy extra charging slots for your different radios for \$12.95 each. The MFJ-641 itself only costs \$49.95—and of course it's protected by MFJ's famous No Matter What™ one-year limited warranty.

To order, or for the name of your nearest dealer, call (800) 647-1800; FAX (601) 323-6551; E-mail [mfj@mfjenterprises.com]; or explore the Web site at [http://www.mfjenterprises.com].

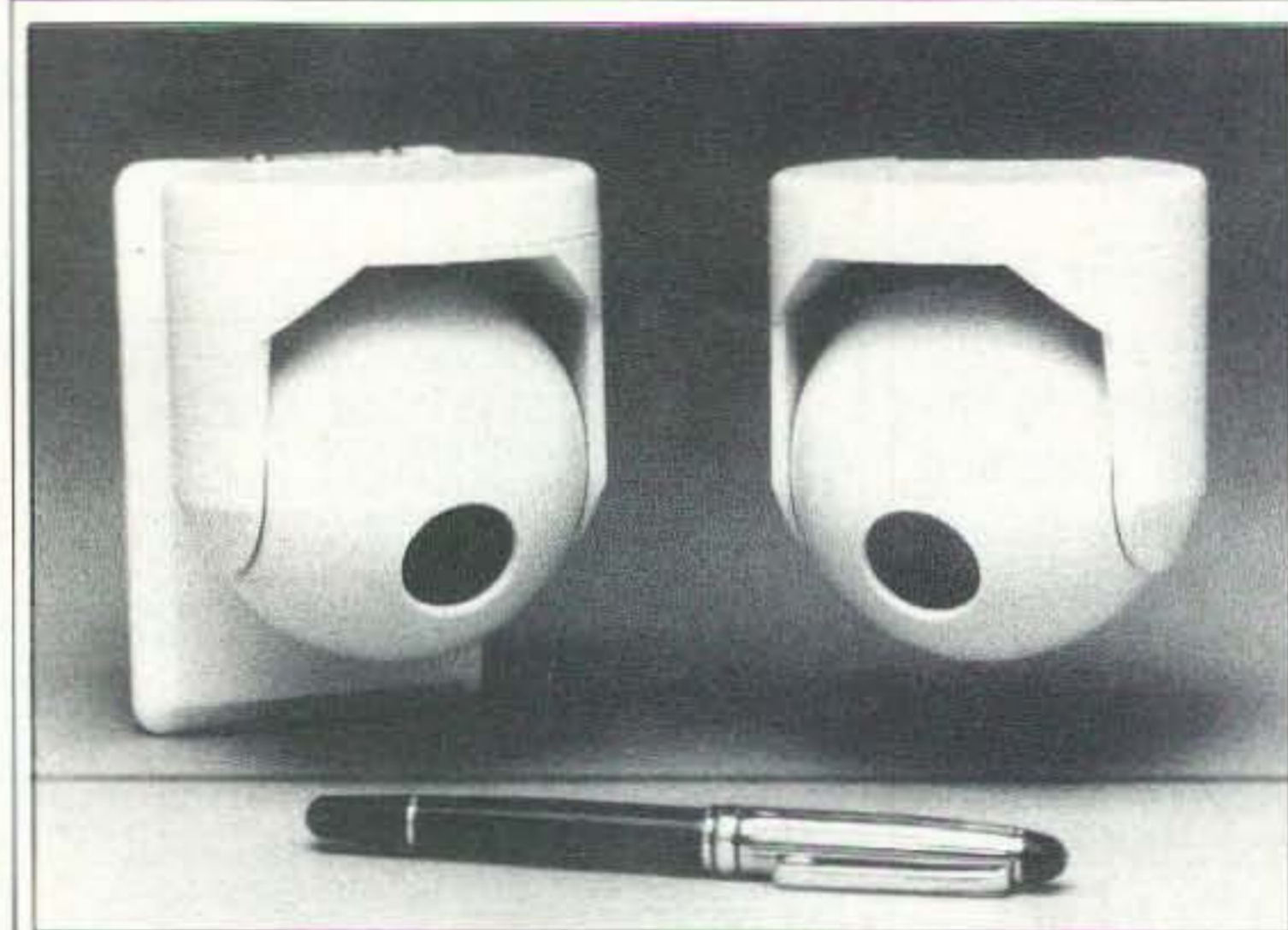

I DON'T KNOW, MURGATROYD ... WHAT DO YOU THINK IT WANTS?

Seriously, it's the next generation of ball cameras from the surveillance-with-style folks at CCTV Corp.: the new black and white BC-450 and the color BC-935C. The pen in the photo is so you can see how small these new guys are—just over three inches in diameter! They swivel 350° horizontally and can be positioned plus or minus 90° vertically to cover angles other ball cameras can't. These discreet cameras come with an easy wall mount that can fit right over a single-gang electrical box for fast prewiring. Both models come with 4 mm lenses but others are optional, as is audio capability. They're stylish enough to pass unnoticed in most interiors but made to be weatherproof, too. They can be used outdoors in temperatures ranging from -10° to 140° F.

For more information, get in touch with CCTV Corp., 280 Huyler Street, South Hackensack NJ 07606. Try calling them at (800) 221-2240 or FAX them at (201) 489-0111.

NEW HAMTRONICS CATALOG

Hamtronics has recently published its 1998 catalog—40 pages of kits and wired units, including some new frequency-synthesized transmitter and receiver products, such as the T301 exciter and the R301 receiver. Hamtronics has also announced that they now stock two-meter and 220 MHz repeaters for next-day shipment.

You may have already received your new catalog. If not, write to Hamtronics, Inc., 65-D Moul Road, Hilton NY 14468-9535; call (716) 392-9430; FAX (716) 392-9420; or E-mail [jv@hamtronics.com]. While you're at it, ask for a complete catalog, which also includes all their VHF/UHF transmitters, receivers, repeaters, converters, preamps, and accessories—and let them know where you saw this announcement. You can also view the entire catalog at their Web site [http://www.hamtronics.com].



NO INTERRUPTIONS

The PowerPort PowerSafe, by Cutting Edge Enterprises, has everything you need for a 75- to 200-amp uninterrupted power supply—except a 12 V automotive battery. Choose from three models for light, medium or heavy use (we know which we'd pick, after the last few months!). All come with a heavy-duty vented battery enclosure usable in the

home, triple-port automobile cigarette outlets for DC, and fully automatic chargers. The Deluxe model also provides 500 W peak AC power (300 W continuous), and the whole works is compact enough to fit under your desk—it's only 18 inches high. During emergencies, or in daily use, whether you're at home or in the field, this snappy Darth Vaderish unit will keep you operating with full power. DC models range from \$66 to \$168, the Deluxe AC/DC model is \$230—and folks here in the Northeast would have been thrilled to pay it during last winter's devastating ice storms!

To order, or for more information about these and other Cutting Edge products, contact Roger Hall at Cutting Edge Enterprises, 1803 Mission Street, Suite #546, Santa Cruz CA 95060. Call toll-free (800) 206-0115 or E-mail [cutedgent@aol.com] and don't forget to tell them where you saw this!

IT'S COMING BACK!

Due to popular demand, Kenwood is bringing back the TM-541A. Many customers have expressed interest—and Kenwood listened! If you were familiar with the TM-541A, you already know about the 1.2 GHz single-band transceiver, the maximum 10 W RF output, the 20 multi-function memory channels, multi-scan capability—and all the rest of the great features! Hang around at your dealer's until you can get a new one of your own.

Your new product announcement could be here! Contact Joyce Sawtelle at 1-800-274-7373, or send good photo and information to *73 Magazine*, 70 Route 202 North, Peterborough NH 03458.

ADVERTISERS' INDEX

R.S.#	page	R.S.#	page	R.S.#	page	R.S.#	page				
351	Absolute Value Systems ... 26	• Dayton Hamvention	27	248	Motron Electronics	34	Ramsey Electronics	11			
68	Advanced Battery Systems 81	114	E. H. Yost	25	64	Mouser Electronics	254	Ross Distributing	69		
•	All Electronics Corp. 16	•	Electronics Book Club	17	114	Mr. Nicd	36	Scrambling News	30		
16	Astron Corporation	2	75	Fair Radio Sales	45	•	OFS WeatherFAX	69	241	Seagon Company	69
41	Barry Electronics Corp	29	193	GGTE	9	•	PC Electronics	59	167	Sescom, Inc.	39
42	Bilal Company	43	•	Hamtronics, Inc.	CV2	•	PC Electronics	73	188	SGC, Inc.	15
355	Biological Hamming	46	42	Isotron	43	•	Peet Bros.	19	250	Software Systems	
56	Buckmaster Publishing	39	242	Jan Crystals	39	68	Periphex	81		Consulting	30
168	Buckmaster Publishing	46	158	Japan Radio Co.	CV4	•	Radio Book Shop	16	69	Spectrum Electronics	30
222	Byers Chassis Kits	43	•	Kachina Communications CV3		•	Radio Book Shop	33	141	The Nicad Lady	31
184	C & S Sales, Inc.	33	•	Kantronics	1	•	Radio Book Shop	46	•	Thomas Miller	44
186	Coaxial Dynamics	9	275	Lakeview Company, Inc. ...	39	•	Radio Book Shop	57	269	Tigertronics	51
99	Communication Concepts 31	335	Menu Plus	5	86	•	Radio Book Shop	63	22	Tri-Ex Tower	
10	Communications Specialists 33	86	MFJ Enterprises	7	•	Radio Book Shop	71			Corporation	57
268	Computer Automation		•	Michigan Radio	35	•	Radio Book Shop	86	•	Universal Radio	45
	Technology	75	160	Micro Computer Concepts 26		•	Radio Book Shop	87	259	Versatel Communications .	44
166	Cubex	45	193	Morse Tutor Gold	9	•	Radio Book Shop	88	182	Vostek Electronics	71

When you buy products from these advertisers, please tell them that you saw their ads in 73.

Subscribe to 73 right now...call 800-274-7373 (9-5 Monday-Friday EST).

AMATEUR TELEVISION

Web site: www.hamtv.com

GET THE ATV BUG



≥10 Watt pep
Transceiver
Only \$499
Made in USA
Full Color
and sound

TC70-10 420-450 MHz ATV Transceiver

ATV is no more difficult to get on vs. any voice mode except you just plug in your camcorder to transmit, and your TV set to receive the picture and sound. That's it - you're seeing as well as talking to other hams live and in color just like broadcast TV. No other radios, computers or interface boxes required.

DX is 90 miles snow free line of sight using 14dBd ant.

Show the shack, home video tapes, zoom in and describe projects, show computer graphics or programs, repeat SSTV or even Space Shuttle Video and audio if you have a TVRO. Go portable or mobile, do public service events, RACES, AREC, CAP, transmit the local radio club meet.

HAMS; Call, Write or Email for our 10 page ATV Catalogue for more info - We have it all! Transmitters, Downconverters, Amplifiers, Repeater modules, and more. We also have wired and tested boards for the builder, R/C, Rocket and Balloon ATVers.

(626) 447-4565 M-Th 8am-5:30pm pst Visa, MC, UPS COD
P.C. ELECTRONICS Email: tomsmb@aol.com
24 Hr. FAX (626) 447-0489
2522 Paxson Lane Arcadia CA 91007

Motron

310 Garfield St Suite 4
PO Box 2748
Eugene, Oregon 97402

<http://www.motron.com>

New DTMF Decoder

\$59.00
plus shipping

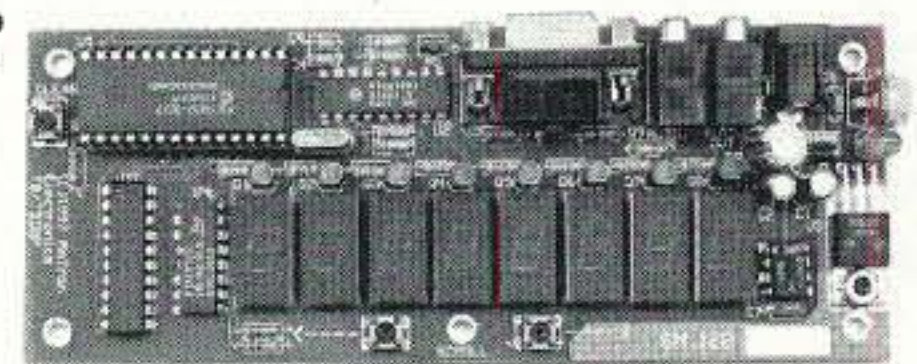

The **ToneLogger™**

DTMF Decoder Display Board with ASCII Serial Output decodes all 16 DTMF digits and features a large 8-digit LED display, an amplified audio output, jumper selectable Normal and High-speed decoding, and an ASCII serial output at 9600 baud. The 56 character memory is viewed, without loss of data, by scrolling either left or right. Although a computer is not required, the serial ASCII output allows for automatic logging of decoded number groups. Logging software for both DOS and Windows environments is included with each **ToneLogger™** purchase. The **NEW ToneLogger™** is 2-1/4" x 6" and requires 9 VDC at a minimum of 150 ma current.

ToneLogger™ Assembled & Tested PCB	\$59.00
CAB-3 Audio & Computer Cables	20.00
PMK-1 Plastic Mounting Kit	15.00
PS-9/2 9 VDC @ 200 ma AC Adaptor	10.00

Visa, MasterCard, American Express, and Discover/Novus accepted.
COD \$5 (Cash or Money Order only) S/H: \$8 USA; \$11 Canada; \$16 Foreign

Orders: (800) 338-9058

Info: (541) 687-2118 Fax: (541) 687-2492

RTTY LOOP

Amateur Radio Teletype

Marc I. Leavey, M.D. WA3AJR
P.O. Box 473
Stevenson MD 21153
[ajr@ari.net]

Last month, we had a look at a high-tech tool to help the RTTY ham, a CD-ROM from Joerg Klingenfuss with all kinds of RTTY frequency data. This month, a different tool to use to get around the spectrum. Stan Wilson AKØB had been visiting the RTTY Loop Web site, and said, "I have noticed that it is hard to locate stations using Baudot on the HF ham bands. Do you know of any frequencies that would be good ones to monitor?"

And David Kent K4UJA asked, "I recently decided to monitor RTTY, out of my general interest in both VHF/UHF packet and satellite data communication. I purchased Brian Beezley's excellent program RiTTY2.0 and I'm impressed by its ease and efficiency when I locate a signal and that's the reason I'm sending this message. Where are the signals? I spent some time looking through the Library section of the RTTY Loop Web page hoping to find some mention

of RTTY/PACTOR active sections of the spectrum but so far I haven't run across any. I don't mean for you to provide them to me but I would appreciate some guidance to articles, columns or links that may provide specific frequency groups to monitor for HF digital traffic, amateur, commercial, news, etc. ..."

Of course, ham stations are still commonly heard around 3620 kHz and 14.080 MHz. On the other hand, if it's commercial or governmental stations that you are after, *Klingenfuss' 1998 Guide To Utility Radio Stations* is the latest edition of this amazing compilation of digital frequency data. Within its 560 pages, you will find almost 12,000 frequency listings for some 2,000 stations.

Whether you are looking for a radio beacon or a PACTOR station, you are likely to find it here. With over 8000 changes since the last edition, this is a ready reference for the digital spectrum. The *Guide* is available for 80 DM from Klingenfuss Publications, Hagenloher Str. 14, D-72070 Tuebingen, Germany.

You could also E-mail them at [klingenfuss@compuserve.com], or check the information on their Web site at: [http://ourworld.compuserve.com/homepages/Klingenfuss/]. Whatever you do, be sure to mention "RTTY Loop" when you call, OK?

Regards to Ralston Gober, D.D.S. W5ZNN, a long-time reader of the column, who says he is "... going back into RTTY again for the umpteenth time. I will not bore you too long since you have probably been

at it longer than I. However, I started with an old Kleinschmidt Clunker, and went to the Model 14, and up the line to the computer."

Among his accomplishments, Ralston includes news of his children and grandchildren, and the fact that he has been mayor of Corsicana, Texas. And I thought I was busy!

Gary Rogers WR7L, of Kennesaw, Georgia, passes along his regards as well. An old-time enthusiast of Baudot RTTY mode, he spends his days working for Turner Broadcasting in the Entertainment division. Another ham whose interest in RTTY has been rekindled, he says "I obtained my license in 1964 at the age of 14. I had my first Model 15 at age 16. I still have a Model 28 ASR at home and can punch out the old tape and receive on my ST-6 Demod. I have been off the air for quite a while in the RTTY mode, but your article has caused me to get the station back together again. I'm working on it right now to get it going so I will soon be on the air again. Does anyone sell the Reperf tapes any more? Or parts for the old machines? Are there any RTTY Nets around any more? Are there any associations left that specialize in RTTY? Just wanted to let you know that you're not alone when it comes to smelling oil and hearing the mechanical melodies of the teletype in the ham shack. I for one want to be on your team to keep RTTY alive and well."

Well, as we discussed a few months ago, there are several sources for radio teletype parts, including Typetronics, among others. Keep on trucking, Gary, and let us hear about your progress on RTTY.

Progress can be measured in many ways. Mike Stapp KEØWW, of Minneapolis, boasts that during the recent ARRL RTTY Roundup, he ran "QRP from a Kenwood TS-450, dipole, MFJ TNC and LAN-Link software. Got 57 QSOs, 30 states, five Canadian provinces,

and HH2 for DX. Ran five watts most of the time but occasionally down to three watts :-). Fun!!!"

So, can it be done?

Manuel Martins CU3FM passes along a problem, though. He writes: "I have an FT-840 and an MFJ 12178B TNC. I am getting tired of trying to do RTTY with Multicom for Windows® and getting just a bunch of garbled letters, numbers, and symbols, nothing understandable. Do you guys know any trick to get this thing working properly on RTTY? I already did HF packet, why not RTTY?"

OK, folks, can anyone help Manuel? Pass it along to me for inclusion in a future column.

Thanks to Michael Trowbridge KA4RRU, who says that he still has a VIC-20 and AIR-1, in duplicate. He just can't help himself at hamfests! Thanks for the words of good wishes on the more-than-21-year run of RTTY Loop.

Dale Braun WD9GWH is another vintage teleprinter enthusiast. He is curious about what activity there might be nationally concerning using vintage teletype equipment. "I've had lots of fun lately using a Model 19 teletype, even using it in the latest RTTY Roundup contest, making 85 contacts."

Watch here for more information on Internet sites and the like for those of us who have never grown up!

Several folks have mentioned the "RTTY Loop" home page at [http://www2.ari.net/ajr/rtty/] and have found information either there or through the page. There is also an index to the RTTY Loop Software Collection, which continues to grow at a regular pace. Check it out, and send me your comments and questions at the above E-mail or snailmail address. I always look forward to your comments. No foolin'!

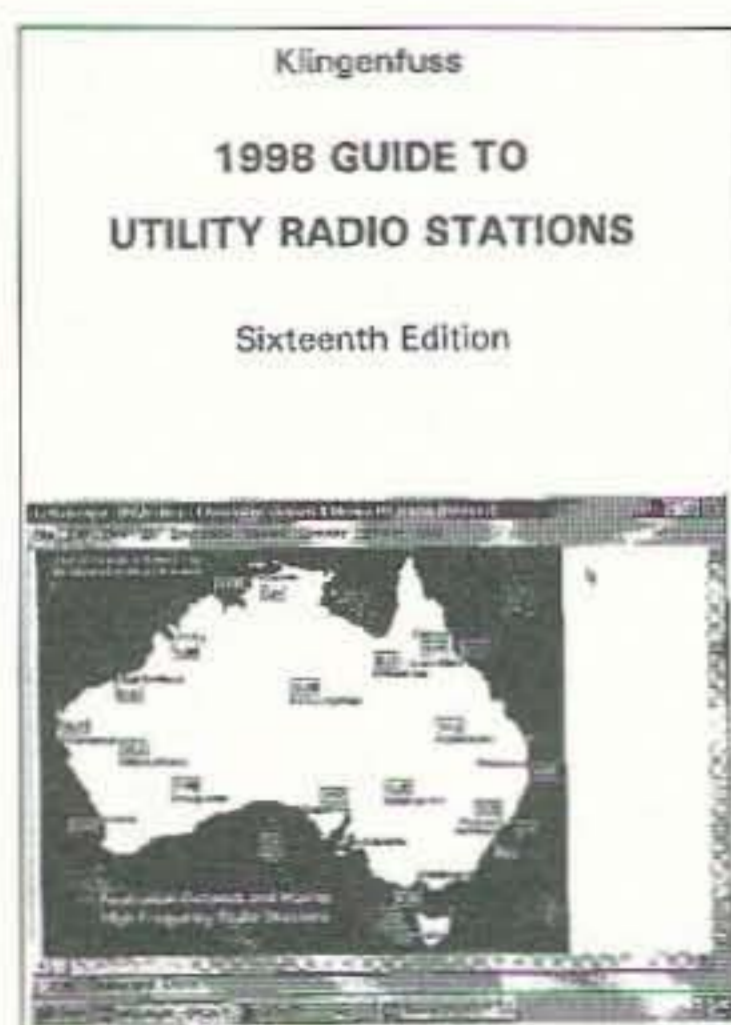

Fig. 1. Klingenfuss Publications' 1998 Guide To Utility Radio Stations.

Low Power Operation

Mike Bryce WB8VGE
SunLight Energy Systems
955 Manchester Avenue SW
North Lawrence OH 44666
[prosolar@sssnet.com]

Operating QRP while portable is a rewarding pastime for me. Even if it's nothing more than setting up the rig on the back deck, it's a lot of fun. Of course, operating portable means battery power. Yes, I've talked about this before—but many a QRP operator runs his entire station from battery power. Unless you're really, really into low power, a small battery just will not keep up with an active operator. A bit more bang is needed to keep your station up and running for the long haul.

Since I've yet to get the solar arrays and battery bank reassembled, all operating has been with midsized sealed lead-acid batteries. My largest unit has a capacity of 32 amp/hrs. Looking into the future, the solar array will be about 2.5 kWp and will have an operating voltage of 48 volts DC. All stored energy will be converted to 110/220 volts AC for use by the home. In the shack, this now converted power would again have to be downconverted to 12 volts DC. Yes, I could use a high-current DC-to-DC converter. In the back of my mind, I worry about RFI being generated by the converter. So, the use of large-capacity sealed lead-acid batteries in my shack may prove to be the norm.

An experimental high-current sealed battery charger

While it's more than possible to completely recharge a battery with just a trickle of current, the length of time required is a disadvantage. Using a high-current supply is another problem. A completely discharged battery will draw as much current as it

can handle, usually exceeding the maximum current allowed by the battery. In extreme cases, it's possible for the battery to actually explode during an uncontrolled high current charge. Now I don't know about you, but something like that would completely ruin my day!

Sealed lead-acid batteries are a unique breed. While they operate just like their flooded-cell brothers, they require a more controlled charge scheme. They are sealed, yet the batteries must vent to release pressure during heavy charging—but you don't want to vent the batteries too much, as that dries out the gelled electrolyte. (The venting does not cause the drying effect; it's the overcurrent during recharging that displaces the water in the gel, causing the vents to pop.)

Sealed batteries are used as standby power sources, such as emergency lighting; or cycle use, with a discharge/recharge cycle every other day. In my case, my batteries are cycled every few days. The charger must be able to recharge the battery in the quickest amount of time, but without damage. The charger must also prevent damage to the battery once the battery has been recharged. Putting back the 90 percent charge is easy—it's that remaining 10 percent that's tricky.

The circuit

I've been working on this circuit for the past several months. Nothing is carved in stone, so you are encouraged to change or expand on my design.

Here's how it works. I used a transformer with a current

capacity of six amps. This gives me plenty of room to expand and allows the transformer to operate cooler. A bridge rectifier and a capacitor form the basis of a simple power supply. Since this is a charger and not a supply, the input filter cap value is rather low.

An LM317 three terminal adjustable regulator is used as the primary voltage source. With a 5 k trimmer resistor in the adjust lead, the LM317's output voltage has a range of between 10 and 20 volts. The output of the LM317 drives an NPN driver, a 2N3055, which in turn provides base drive for another 2N3055. The LM317's adj trimmer sets the output of the last 2N3055 for roughly 15–17 volts. This section of the charger makes up the bulk of the current source.

An NPN transistor, a 2N4401, is connected to the adj line of

the LM317. Base drive for this guy is provided by one section of an LM324 op amp. This one section of the op amp is configured as a voltage comparator.

In the negative lead of the battery, a 0.1 ohm five-watt resistor provides a 100-mV drop for each amp of current flowing into the battery. The resulting voltage generated by the resistor is fed into the op amp. A 7808 regulator provides a reference voltage source. Three resistors form a simple voltage divider, with the trimmer resistor setting the actual output of the divider. This is the reference voltage used to compare the voltage drop generated by the current sensing resistor. Remember, for each amp flowing through the 0.1 ohm resistor it will drop 100 mV. Our voltage divider may be set from 1 volt (10 amps) to 100 mV (1 amp) and just about any place in between.

Continued

CAT-1000 Repeater Controller

Attention Repeater Owners!

The CAT-1000 is packed with features normally reserved for controllers costing a thousand dollars or more.

Features Include:

- * TI Voice Synthesizer
- * DTMF Regenerator
- * Forty Voice Messages
- * DTMF Key-Pad Test
- * Digital Voice Clock
- * DTMF Audio Muting
- * Grandfather Clock
- * Full Feature Autopatch
- * Forty DTMF Paging Memories
- * Two CW Identifiers
- * Sixty-Four Control Functions
- * Doug Hall RBI-1 Interface
- * Forty Link Preset Frequencies
- * DTMF Command Generator
- * Link Serial Tuning
- * TS440 HF Remote Base
- * Ten Emergency Speed Dials
- * Reverse Autopatch
- * Autopatch Cover Tone
- * Link Auto Disconnect
- * Eight User Function Switches
- * Forty Macro Strings
- * Phone Number Read Back
- * Eight Memory Saves
- * Caller ID Suppression
- * DTMF Repeater Access
- * Sixty Position Scheduler
- * Ten Programmable Courtesy Tones
- * Three-Hundred User Speed Dials
- * FT767GX HF Remote Base
- * Phone Number Lock-Out
- * RS232 Interface
- * Eight Hardware Inputs
- * DVR Controller Ready
- * Programmable Prefix Codes
- * TTL Computer Interface
- * Nineteen Programmable Timers
- * Two-Tone Paging
- * 300 baud on Board Modem

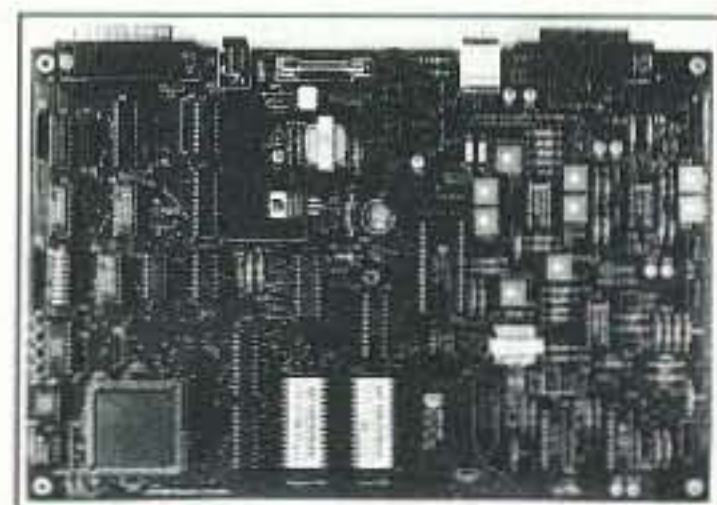

CAT-1000 Controller Board \$679.00. Wired and Tested.

Write or Call for a brochure describing the CAT-1000 Controller including schematic, voice word list, and control functions. Other Controllers with autopatch and TI voice synthesizer are available starting at \$299.00.

Computer Automation Technology Inc.

4631 N.W. 31st Avenue, Suite 142, Fort Lauderdale, Florida 33309
Phone: (954) 978-6171 - Fax: (561) 488-2894
Internet: <http://www.catauto.com>

HOMING IN

Radio Direction Finding

Joe Moell P.E. KØOV
P. O. Box 2508
Fullerton CA 92837
[Homingin@aol.com]
[http://members.aol.com/
homingin/]

Build the Montreal Fox Controller

Have you started building your foxboxes yet? Last month's "Homing In" showed you how obsolete business-band transceivers, discarded medical batteries, and military surplus ammunition boxes can slash the cost of making transmitters for international-style radio-orienting (also called foxtailing and ARDF). Now you can save some serious cash on the control circuits, thanks to two generous hams in Montreal.

A controller board is the brains of a fox transmitter. For radio direction finding (RDF) contests under International Amateur Radio Union (IARU) rules, it makes the fox transmit for exactly one minute at its correct point in the sequence of five transmitters. It generates the appropriate CW message (e.g.,

MOE for fox #1) throughout the transmission and the station callsign at the end. Delayed starting and automatic shutoff after the hunt are other desirable controller features.

In 1970, I built my first solid-state CW callsign generator for a UHF repeater. It was a big improvement over a mechanical code wheel. It didn't seem like a big drawback that it had 20 discrete transistors and 80 diodes and required almost a square foot of perforated board to hold everything. If I hadn't spent several hours manipulating logic maps of the dits and dahs in my callsign, it would have taken over 200 diodes. Today, one IC and a handful of other parts will do all that, plus provide transmitter control and timing to meet IARU rules.

One-chip microcontrollers using reduced-instruction-set architecture are revolutionizing

you desire. If the shunt resistor were to be placed in the positive side, a separate supply would be necessary to run the op amp.

I may change the way the current limiting operates. By controlling the FET via the current limiting op amp, we could eliminate the PWM from the LM317. I've not looked at the spec sheets for the LM317, so really can't say for sure if running the adj line on and off will damage the LM317.

As I mentioned in the first part of the column, this project is just a starting point. Refinements will be necessary to suit your needs, as well as mine. I'll keep you posted on any changes that I've worked into the charger. 73

the design of logic circuits. CMOS technology minimizes current drain, while EEPROM or flash memories retain data through power-off periods and permit simple reprogramming in the field. Peripheral Interface Controllers (PICs) by Microchip Technology Incorporated are among the most popular microcontrollers for amateur radio home construction projects.

When I visited Montreal last October, I was shown a nifty little PIC controller for mobile T-hunts. I encouraged its developers (Jacques Brodeur VE2JX and François Tremblay VE2EMM) to make a special version for IARU radio-orienting standards. They soon did just that. By eliminating the DTMF controlling/programming feature, it became a simple one-IC project. Raw parts cost for five controllers is about \$15 each, not including shipping, circuit board, and programming of the PIC.

Two controllers in one

The Montreal Fox Controller uses a 16F84 reprogrammable PIC with nonvolatile flash memory. An inexpensive 4.194304 MHz microprocessor crystal (X1) provides timing accuracy and synchronization through long hunts, with about one second variation in six hours. The MCW output is a keyed tone to drive the mike input of a two-meter FM rig. The CW output is an open-collector pulldown for on-off keying of an A1 transmitter per IARU rules on 80-meter foxhunts.

MOx messages are sent in slow code, but station ID is sent at about 20 WPM, to avoid hunters confusing the callsign with the fox number. You can put out your foxes in advance and have them come on automatically at hunt time. Delayed startup is programmed with DIP switches in 30-minute increments from zero to three-and-a-half hours.

Fig. 1 is the complete schematic of the Montreal Fox Controller. Most of the parts should be locally available. Digi-Key Corporation [701 Brooks Avenue South, P.O. Box 677, Thief

River Falls MN 56701; (800) 344-4539] carries all components, including the unprogrammed PIC IC.

VE2JX and VE2EMM are making the PIC program for this project available to all hams for ARDF and other noncommercial purposes. They don't want to go into the circuit board or parts business right now, so I am arranging for circuit boards to be sold by FAR Circuits [18N640 Field Court, Dundee IL 60118; (847) 836-9148]. As of this writing, the FAR boards are not yet fully checked out and ready to go. There may be additional sources of boards in Canada and Australia by the time you read this.

My original plan was to include all the circuit board and programmed PIC sources in this article. However, the development of this project was slowed greatly by the monstrous ice storm that struck Montreal in early January. "Four inches of ice formed on everything," Jacques wrote when his Internet access resumed. "Just imagine the weight! The downtown Montreal area was closed for removing the ice on the tall buildings—it was falling on the people. Hundreds of pylons for the transport power lines are down, tens of thousands of poles are broken, and the distribution network is so damaged that they say it cannot be repaired. It will have to be rebuilt to new completely. People could not use their cars, because the streets were littered with poles, trees, and electric lines. All business, industry and farming in the area stopped. Cows were dying, many farmers could not milk them."

As I write this two weeks later, 250,000 homes are still without power in the Montreal area. Not surprisingly, François and Jacques have been busy with emergency communications and their ham projects have been on hold. So check the "Homing In" Web site, where you will find an up-to-date list of sources for circuit boards and

QRP

continued from page 76

the "N" channel, but they are expensive and hard to obtain.

A heat sink will also be required on the 2N3055 pass transistor. If you intend to use an encapsulated bridge rectifier, it too will need a heat sink. Other than that, there are no restrictions on construction. Use of an IC socket would be a good idea for the LM324.

Changes in the wind

I really don't like to place a current shunt in the negative lead. It is cheap and dirty, but requires the negative side of the charger to float. The battery negative may be grounded if

value of R4 and/or provide a beefier transistor at Q2. The same is true of R3 and Q1 on the CW/80m output. The RA1 and RA2 outputs of the 16F84 will source up to 20 mA.

François and Jacques added several components for "insurance" purposes. C7, C8, and C9 prevent problems from spikes and noise, so they may not be mandatory in your application. D2 and D3 protect Q1 and Q2 from the inductive kick of relays and are needed only if your transmitter has them. If you will use your controllers only on two meters with MCW audio, you can delete R4, C8, Q2 and D3. Conversely, if your unit is only for an 80-meter CW fox, leave out R1, R2, R4, R9, C4, C5, C6, C8, Q2, D3, VR1, and JP2.

U2, D4, and C10 are optional. Maximum current drain of the PIC circuit is only eight milliamperes, half of which is indicator LED1. Three AAA alkaline batteries will power it for over 150 hours. U2 and associated components allow you to eliminate the batteries and power the board from the same +8 to +14 V source that powers your fox transmitter. Remember that any power interruption resets all the PIC timers, so don't disconnect power after you synchronize the foxes for a hunt. Using batteries in addition to the regulator provides backup to carry the timer through any external power interruptions. Schottky diodes D1 and D4 (1N5817) prevent the batteries and regulator from damaging one another.

Ready to test?

Before installing the PIC in its socket, check your workmanship. Make resistance measurements to verify that one terminal of each push-button and DIP switch section is connected to circuit ground. Close all DIP switches and jumper JP1. The emitter of each transistor and pins 2, 5, 6, 7, 8, 9, 10, 11, 12, and 13 of U1 should show continuity to ground. If you included regulator U2, apply +12

volts to the input and verify +5 volts at the output. With JP1 removed and power applied from fresh batteries or U2, verify that about +4.8 volts is present at U1 pins 2, 3, 4, and 14, but not other pins.

If everything checks out OK, then remove power, install JP1, plug in U1, and try it out. Set the DIP switches for continuous cycling, fox #1, and zero delay per **Table 1**. Apply power, press SYNC/RESTART (S3), and view LED1 to verify that the unit sends MOE nine times in slow CW, then identifies rapidly as DE FOXBOX.

Besides flashing the CW characters, the LED provides other operational indications. During the delayed-start wait time, it flashes once per second. If you set the DIP switches for an improper combination, such as fox #5 cycling once every three minutes, it flashes rapidly to signal your error.

DIP switches S1-1 through S1-9 determine the fox number and message as shown in **Table 1**. In accordance with IARU regulations, fox #1 sends MOE continuously at about 8 words per minute. Fox #2 sends MOI, fox #3 sends MOS, and so forth. Even if you don't know CW, you can determine which fox you're hearing by counting the dits after MO (which is "dah-dah, dah-dah-dah").

The IARU does not prescribe the message for fox numbers greater than five. In the VE2JX design, fox #6 sends MON (ending in "dah-dit") and fox #7 sends MOD (ending in "dah-dit"). For fox tailing events in a very large park where contestants can get lost, there is usually a fox on a separate frequency sending MO continuously at the finish line, which is usually at the same place as the start. Such a mode is provided in this unit.

Pressing the SYNC/RESTART push-button (S3) with JP1 in place causes the microcontroller to read the octal code settings of S1 and commence operation in accordance with these settings. Press S3 when you power up,

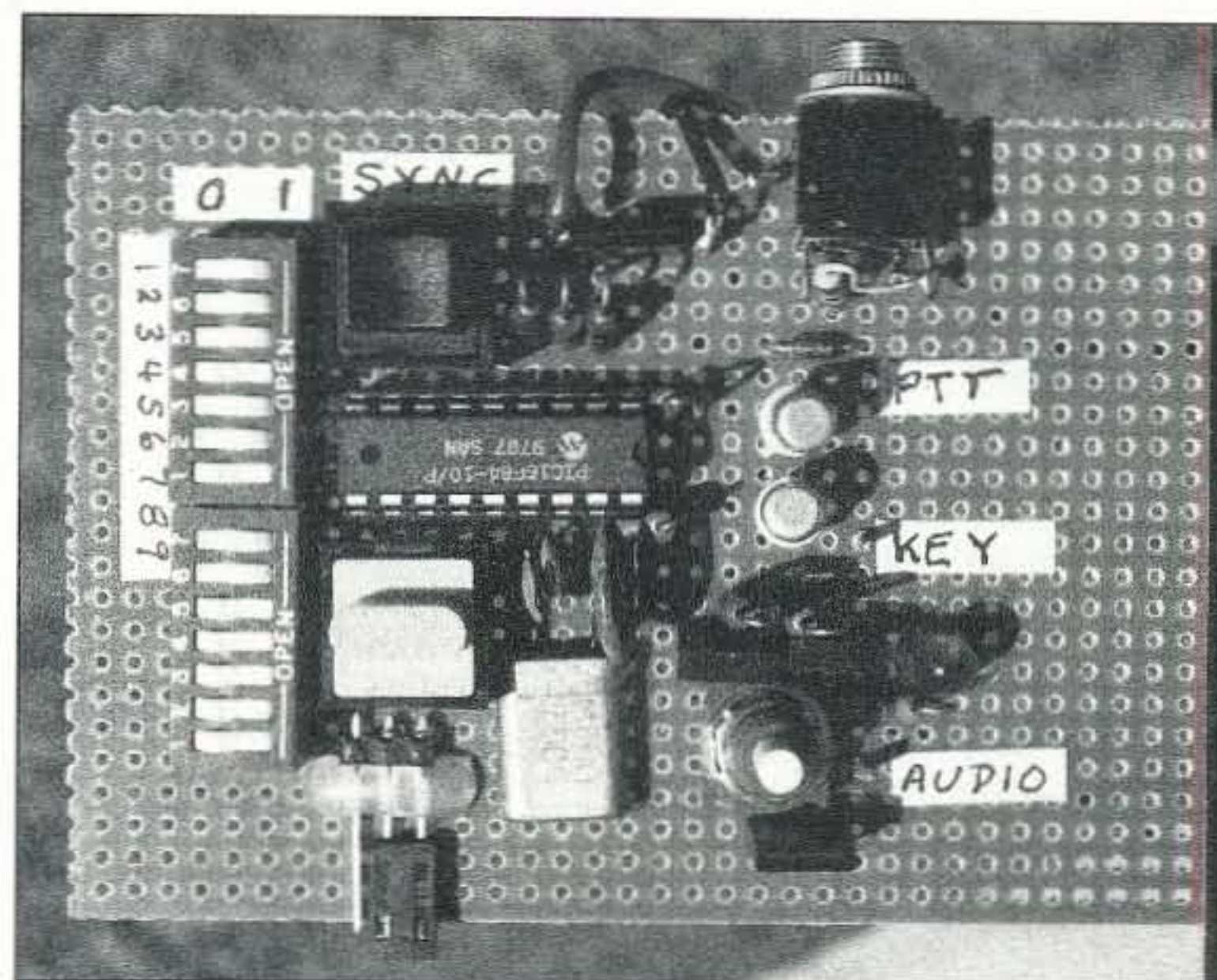

Photo A. Prototype of the Montreal Fox Controller on perforated circuit board. To facilitate program changes, be sure to provide a socket for the PIC.

when you change modes, and when you begin a delayed start cycle. To operate a set of IARU-style foxes in sequence, set the DIP switches in each one to its unique fox number. The setting for number of foxes and start delay must be the same for each fox. Now press S3 on each unit simultaneously.

You don't have enough fingers? OK, connect the SYNC terminal on each unit together and short this connection to circuit return (ground) momentarily to perform the restart. Of course, the circuit returns of each board must also be connected together to do this. If you

will be synchronizing several foxboxes regularly, make up a wire harness just for this operation.

Station identification remains in data memory when power is removed. Changing it from FOXBOX to your own callsign is a simple procedure. Monitor the CW tone output at RA0 (U1-17) with headphones or a speaker amplifier. (Computer speakers work well for this.) Alternately, you can watch the CW flashing of the LED. With power on, remove jumper JP1 and press SYNC/RESTART.

Continued on page 85

Setting	Cycle	Message	Delay
x,x,x	S1-9,8,7	S1-6,5,4	S1-3,2,1
0,0,0	Continuous	MO	None
0,0,1	Continuous	MOE	0:30
0,1,0	2 minutes	MOI	1:00
0,1,1	3 minutes	MOS	1:30
1,0,0	4 minutes	MOH	2:00
1,0,1	5 minutes	MO5	2:30
1,1,0	6 minutes	MON	3:00
1,1,1	7 minutes	MOD	3:30

Table 1. DIP switch settings for transmit cycle, fox message, and start delay.

Millen-Dollar

continued from page 49

utilized. If it remains exposed, it is a potential shock hazard.

Fortuitously, I had a short length of blunt-ended shrink tubing in the shack. I dressed it for length, snipped off (like a cigar) a small opening in the end, and slipped it into place. This allowed the rear lug to push through for subsequent soldering (see **Photo C**). I exposed the shrink tubing to a little stovetop heat to complete this task.

In very high voltage applications, you may want to further insulate the completed disconnect module from ground with a piece of Plexiglas. Prepare a small right angle bracket (**Photo D**) and mount the disconnect to the insulating material through a one-half-inch drilled hole. If you require a through-chassis mount assembly, cut an opening in the deck approximately one and three-quarters inches square. Drill a half-inch hole in the center of a piece of insulating material measuring about two and one-quarter inches square to accept the fused disconnect.

Center the modified fuseholder in the chassis opening and drill through



Photo F. The completed RF deck resting comfortably above a circa-1964 power supply. All voltages originate from the lower unit and must be cabled to the RF deck via quick disconnect assemblies.

the chassis and insulating material to accept some nut/bolt mounting hardware. The added distance to chassis ground afforded by the insulating material will insure against any possibility of arcing to chassis ground (**Photo E**).

The rest's a snap!

Solder the far end of the HV wire to the DC output source within the power supply. If your installation requires the wire to pass through the chassis, use a grommited hole to protect from chafing and to avoid the possibility of short circuiting. On the RF deck, wire up a length of HV wire from the solder tab at the rear of the fuseholder to the base of the HV plate choke.

Route the wire to avoid any possibility of short circuiting, and (plastic) clamp it along its length to avoid movement. Use any remaining epoxy (or silicone seal if you prefer) to build up an insulating shield over the rear tab to eliminate the possibility of an accidental jolt from the exposed HV potential.

It may be a good idea to add a bit of additional insurance against any accidents should the high voltage wire somehow pull out because of some inadvertent tug on that line. Secure the HV lead with a plastic strain insulator clamp attached to the chassis and positioned as close as practical to the input of the fused disconnect. It's clear sailing from there on in. Give it a try. It's a safe, economical, foolproof, and convenient disconnect method for a vitally important aspect of an amplifier construction project. 73

NEVER SAY DIE

continued from page 5

Big corporations tend to play it safe. They wait for entrepreneurial companies to develop new technologies and then they buy or steal them. More the latter. But their interest is in getting their investment back as quickly as they can, so they tend to go with well proven technologies and charge top gouge price for their product. They've found they can make up with advertising what they lack in technology. For three, the more they have to pay for a channel, the more they're going to charge us to use it, so

the bottom line is simple: all these billions are going to eventually come from our pockets in higher costs for the products and services we buy.

Gee, what a surprise!

The old FCC approach of holding hearings to determine the best use of frequency allocations had its drawbacks too. But then one would be hard put to point to any government bureau that is not screwing things up more than they are benefiting us.

Hamfest Scams

Well, they're scams for the ham industry, not the attendees. This is what went through my mind as I looked over the usual stack of requests for prizes and ads in hamfest programs. Sigh. Look, guys, I've been exhibiting at hamfests and ham conventions for 43 years, so there are a lot of things that I've learned — mostly the hard, expensive way.

Prizes, for instance. As an attendee my chances of winning anything substantial in a prize is squat. Maybe a gift-certificate discount for something I'm not interested in. As a manufacturer, what do I get out of being a good guy? With some luck, I'll get a "Good Guy" certificate. Period. Yeah, my company will be listed in the hamfest program as a donor. Big deal.

If they want prizes to raffle off or give away I'll be glad to sell 'em to the hamfest prize chairman at my lowest discount price.

If I donate something that the attendee wants, then I've lost a good potential sale. If he doesn't want it, I've wasted my money.

Now, about that big listing in the program. That's about as valuable as running an ad in the program. I tried that for several years. I ran ads for 73 in lots of hamfest programs and never got one single subscription as a result. Not one! I tried all kinds of ads. I tried special prices. I tried chatty ads. Nothing pulled. Finally the light dawned. Nobody ever looks at a hamfest program. They pick 'em up because they're free and take 'em home, where they go up on the shelf. A few years later they go out with the trash. Or they end up in the attic in a box, if the ham is a compulsive collector. Like me.

I used to donate gift subscriptions to the Dayton hamvention®. The organizers were kind enough to provide a sign for my booth saying I was a prize donor. The result of that was about 2,000 hams passing my booth saying they were going to wait and see if they won the subscription. I'll bet I lost a thousand dollars in subscriptions as a result of giving a few freebies away.

In retrospect I might have tried to work this to my advantage by making

the prize bigger — like a lifetime subscription — but valid *only* if the chap had bought a subscription before winning the prize.

Hamfests, if they're going to distribute programs, have to sell ads to help pay for the printing. A few posters around the hamfest area showing the program would do the job and save an awful lot of wasted money.

Why don't hams read the programs? Because there's hardly ever anything of even the slightest interest in 'em. Boring. There's no good reason to look at it.

Of course, if hamfests could recruit some really interesting speakers and get them to contribute a paper to be published in the program, that might help. I don't think I've ever been asked for anything like that.

Interesting speakers? How many hamfest speakers do you remember who were fun to listen to? My only memory was Jean Shepherd K2ORS, who was fabulous. I'll bet Barry Goldwater K7UGA, King Hussein JY1, or Art Bell W6OBB would draw a crowd. How about movie producer Dave Bell W6AQ?

Global Warming Crapola

If you listen to the politicians, the man-made CO₂ gases are accelerating the warming of the Earth. If you listen to the scientists who are experts in this field they say this is a bunch of baloney. Yes, the Earth has been in a warming period that started 300 years ago, long before Ford popularized the internal combustion engine.

Gore says that "CO₂ and temperature have gone up and down in lockstep." The temperature record for the past 3,000 years shows that the atmosphere during two-thirds of those years was warmer than it is today, with five distinct warm eras. Yet, during all of those warm periods, CO₂ was lower than today. Gore is wrong!

So, based on political, not scientific, rhetoric, Clinton is signing the treaty to limit CO₂ emissions. And what effect will this have? The US Department of Energy has predicted that this will cause a 20% drop in steel production and close down all US primary aluminum plants. These huge industries will have to move to countries that are not signatories to the treaty, such as Mexico and China. The global emissions will be unchanged, we'll have just forced several billion dollars' worth of industries to move out of the US — taking with them all the jobs involved. And all of this is happening because the Democrats have whipped up a lot of fake excitement over the environment, aimed at getting Gore elected president in a couple of years.

Why am I reminded of the movie, *Wag the Dog*?

The scientific facts do more to support Robert Felix's *Not By Fire, But By Ice*, even if they don't agree with the Clinton political agenda. A letter from Geologist Jack Sauers points out that the data from across the northern tier states from Washington to North Dakota shows that temperatures since 1940 have fallen lower than they were in 1890, when the "Little Ice Age" was experienced. This agrees with a similar drop in temperature in every Scandinavian country, also with rising precipitation. It agrees with satellite and radiosonde temperature data. It agrees with tree ring thickness from the Arizona Tree Ring Lab. It agrees with the tree ring density data from the western US and Europe, with the temperature high around 1940. The US Dept. of Agriculture Plant Hardiness Zone map shows a southern deflection of 10°F between 1960 and 1990 maps, which strongly affects plants. The Wildlife Department is reporting that huge numbers of moose have been coming down from Canada to Vermont, New Hampshire, upstate New York, and even Connecticut.

As with cold fusion, where theory and data are in disagreement, it's the theory that should give way, not the data.

So, what can you do? At the least, register an informed protest with your senators and congressman. Second, talk about this on the air and get others to protest this expensive Clinton political media management program.

Games

Your mind, as I've mentioned, is like a muscle — you either use it or lose it. Unfortunately, from what I've been hearing lately on 20 m, an awful lot of hams seem to have lost what little of their minds they maybe once had.

So I keep nudging you to check out some of the more interesting books I've found, and to take advantages of the learning that amateur radio makes possible, and fun. I'm afraid my words fall on blind eyes. "There goes that damned Never Say Die again, trying to get me to think."

Well, how about your kids? The average dad, according to surveys, spends about 15 minutes a week with his children. If you

LOOK!

PERIPHEx™

High Capacity BATTERIES Memory Free!

(800) 634-8132

SUPPLYING AMERICA'S BATTERIES FOR OVER 15 YEARS!

BUY DIRECT!! HTTP://HOME.NAVISOFT.COM/PERIPHEx

15% Off ALL YAESU Replacements! Including NiMH Super High Capacities!!!	DARE TO COMPARE !! Yaesu Replacements	The other guys!	Ours!!
	FNB-25M (7.2v NiMH)	Not Available	900mAh
	FNB-27SM (12v NiMH)	Not Available	1350mAh
	FNB-11M (12v NiMH)	Not Available	1350mAh

Offer expires June 30, 1998.

Charge NiMH & NiCD!!

CALL-NOW!!!

Universal Battery Charger!

NOW ONLY \$49.95 !!

+ FREE GIFT!

Policies & prices subject to change without notice

Amateur Radio * Cellular * Laptop Computer * Alarms

Advanced Battery Systems, Inc. * 300 Centre Street * Holbrook, MA 02343
(781) 767-5516 * Fax (781) 767-4599

have any interest at all in your children growing up able to reason for themselves instead of meekly being pushed around by peer pressure (a.k.a. mob psychology) and the media, then start early playing games with them. I recommend you go more for thinking games rather than games of chance.

Chess, as I've mentioned in the past, is a great game in that it is pure strategy and is much like both life and business in many ways. When I was a kid I enjoyed Peggity, Cubic and Battleship. Peggity has a board with a bunch of holes and the aim is to be the first to get five pegs in a row. That takes strategy. Planning. Cubic is like three dimensional tic-tac-toe, where you have to be the first to get four markers in a row in any direction.

There are a lot of good card games. One of the tougher card games is Russian Bank. You can consult Hoyle on how to play that, but it requires real concentration.

Monopoly® is okay, but it's too much a game of chance. Ditto most other board games. Anagrams is great because it really makes you think and helps to build your vocabulary. Another word game is Boggle®, which was invented by a good friend of mine. If you play it so you have to make words with four or more letters, it's a real challenge. Boggle is played with 16 dice, each with letters on it. You shake 'em up and they fall into a four by four grid. Then, with the clock running, you see how many words you can make using letters that are in contact with each other in any direction. It'll get you thinking and your kids too.

I'm almost addicted to crossword puzzles. I love 'em! They are a great challenge. And any newspaper cryptogram that I happen across I just have to do.

The more you can teach your children to think when they are young, the more their brains will grow during this important development period. This is a great gift of love you can give them. It may, too, also help you understand the little monsters

better. As animal trainers have found, you can teach animals infinitely more through love and understanding than you can through fear and intimidation. I sure wish someone had taught my father that. Fortunately, my mother understood it.

Remember, if you find you "have" to spank your child, you have failed as a parent and a teacher. You are punishing your child for your failure and building more and more of a wall between the two of you, one that will last for life. The child will never again really trust you or believe in you.

As with children, if you are having any problems with animals or any other living things, the problem lies with you, not them. It's your attitude that has poisoned the relationship.

One of the best books I've read about all this is *Kinship of All Life* by J. Allen Boone [\$9 from Dowsers; call (800) 711-9497]. Boone explains how he learned to communicate with all living things from a dog. His story of his adventure with a fly is most entertaining. Before reading this I'd always had problems with flies around the house in the summer. In the spring I'd get out the fly swatters and put one in every room. Then would come daily swatting sessions, particularly in the kitchen.

After reading the book I did what Boone said and had a man-to-fly conversation with the first fly that appeared in the kitchen. Then, instead of swatting it, I opened the screen and let it out. A couple more showed up a few days later and I had a similar discussion with them, and let them out too. It's been two or three years now and the fly swatters are all out in the barn somewhere. I've never had another fly come into the house — which I sort of regret, because I'd like to make friends with a fly.

And while you're at it, if you haven't bought *The Secret Life of Plants* yet, add another \$16 for that one. This will help you to communicate

with plants as well as animals and insects. These are both also available from Radio Bookstore: #5280 and #5300; (800) 243-1438.

Once you get the hang of it, get busy and teach your children how to do it. As Boone explains in a later book, you can use the same approach in dealing with people on a non-verbal level. You'll learn a whole lot more about them this way than just listening to what they're saying.

Flight 800

Yep, I've got more news about that flight. But if you've been listening to the Art Bell (W6OBB) show every night as I've recommended, you'd already know all about this. Art had Bill Donaldson on his show, a chap who's taken the data from the recovered flight recorder and analyzed it very carefully.

Bill explained that the last few seconds of recorded pressure readings could *only* have been produced by an external explosion. It couldn't possibly have been a fuel tank, as the NTSB has claimed. This also helps explain the testimony of scores of people who claim to have seen the trail of a missile heading for the plane just before the explosion.

Is this official bungling, or just one more government cover-up?

And is there any connection with the delay of the El Al flight which was scheduled to be in that time slot? Could the TWA flight have been mistaken for it?

More Dowsing

If, despite my editorials, you haven't yet looked into dowsing, you are, to say the least, curiosity-challenged or being held prisoner by procrastination. If you think that all this paranormal stuff is crap, then you are either ignorant of, or able to ignore, mountains of evidence. Yes, I know and agree that there are also mountains of tompoopery out there. But we have that also in our blessed scientific community, which is still, in

the main, holding on to the Big Bang theory, despite conclusive evidence that it isn't true (which they refuse to look at). Including genius Hawking.

There have been endless scientific tests down through the years which have proved that dowsing really does work. For instance there was a test in 1913 in Paris. The test was to locate a series of quarries which had been dug under Paris since Roman times. The charts of these were unpublished and kept locked away. The tunnels and quarries were 16-20 meters underground. Dowsers proceeded to put stakes in the ground showing precisely the location of the underground tunnels and galleries, including one gallery that no one had known about, but which was discovered as a result of the dowsing.

Arthur Young wrote, "Experimental proof gathered to support the existence of a phenomenon does not guarantee that it will not be ignored or rejected. This is because there is no theory to account for it, and existing theories apparently rule out its reality."

This certainly has been the case with cold fusion, and no amount of confirming research reports have been able to sway the editors of major scientific journals.

But, when we admit the reality of dowsing, that opens the door to remote viewing and a lot of other paranormal realities — like how do animals find their masters thousands of miles away, and how do monarch butterflies know where to go in the winter?

Another book I'll have to add to my *Guide* is *Psychic Animals*, by Dennis Bardens, a truly fascinating book which has been published by Barnes & Noble. How do pets know when something is going to happen to their masters? How can they find them under incredible circumstances, like the dog, accidentally left behind by a ship's captain, who went aboard many ships for several days, finally found another ship heading to the same destination as his master,

and stowed away on it to get there — eventually finding him. How do pets know about earthquakes ahead of time?

Isn't it about time to start investigating what's going on so we can understand it and maybe even put it to some good use?

So, have you procrastinated about getting the Lehto book I've recommended? And Bird's *The Divining Hand?* Ross & Wright's *The Divining Mind* [\$10.95 from Dowsers, (800) 711-9497] is a 130-page guide to dowsing. Yes, you, too, can learn this amazing and unexplainable art.

History

Art Bell had Captain Crunch on his show talking about the old Blue Box days and that reminded me of the time I published a bunch of telephone circuits in 73 (including the Blue Box) and got sued by Ma Bell. That's a helluva story. It was also responsible for Sherry and me getting together. Let me know if you'd like me to write about it.

Art mentioned that Steve Jobs and Steve Wozniak were making Blue Boxes before they started Apple™. How Apple computer got started and my role in all that is another story, but I don't know if you'd be interested in the inside history of Apple — the *real* history that I've never seen covered in any of the books or articles about Apple (except perhaps in some of my old editorials). I don't want to spend my time and your eyeballs on things of little interest to you.

I was also there when the first microcomputer was launched, which is another great story. The rise and fall of the Altair 8800 computer from MITS. Ditto the Sphere micro from Salt Lake City and the South West Tech micro from San Antonio. Or how the Radio Shack™ TRS-80 computer got started and why it died is another fascinating story. To me, anyway, and I knew all the people involved personally.

Another great story has to

do with the Texas Instruments™ TI-44/a computer and how they managed to lose \$630 million on the project instead of making billions, which was easily within their grasp. I was in the middle of that whole business too.

Then there's the story of how American Mensa got started. I was one of the five at the very first meeting back in 1960 and was the first secretary of the organization.

Somehow I've managed to be at the right place at the right time for a lot of interesting things. So let me know if any of this ancient history is of interest to you.

The Generals

Way back in 1955, shortly after I'd gotten Perry Ferrell, the old editor of *CQ*, a better job as editor of *Popular Electronics*, *CQ*'s publisher talked me into being the new editor. I'd been doing the RTTY column for *CQ* and also publishing a RTTY journal (*Amateur Radio Frontiers*) for several years, so the job offer wasn't completely out of the blue.

Part of the deal was the hiring of Jim Morrisett K2OLK as my assistant editor. I'd met Jim in 1950, when we were both at the Hubbard Dianetic Research Foundation in New Jersey. But that's another long story.

My first action as the new editor was to convince my old friend Sam Harris W1FZJ to sign on as the VHF editor. Jim and I drove up to Boston and stayed a weekend with Sam, cementing the deal. Sam had a psychological problem — he *had* to have the biggest signal in the world on any band he was on. As W8UKS in Cleveland he had a bi-square beam on 75 m and was running a Collins 32V. As I recall, it had about 50 watts output on AM. I was running a kW to a half-wave antenna in Brooklyn. When I'd try to break in on his contacts with South Africa the ZS would say he thought he could hear a slight heterodyne on Sam's signal. That was me. They'd then let me into the contact.

I eventually forced Sam to

move to Puerto Rico so he could use the big dish at Arecibo. I did that by setting up my station on the highest mountain in southern New Hampshire and running a kilowatt (AM) to a 336-element beam on 2 m.

Our second action was to visit Dick Spenceley KV4AA, down on St. Thomas. Dick had been unhappy about Perry, who was not a ham, as the old editor. Jim and I had a great visit. We rented scuba gear from Leslie Caron's father, who ran a dive shop, and dove all around the island. Jim and I had a great time, eating locally-grown bananas, coconut, soursops, and sugar apples. But we noticed that the local people didn't seem much interested in this food, preferring to buy imported canned food. Dick explained that only poor people ate the local food, so as soon as anyone made any money they started buying imported food. And getting sick.

Societies which eat locally grown fruits and vegetables and haven't yet been introduced to refined sugar and white flour don't get cancer or have heart attacks or strokes. But when they shift to white rice and white flour, where the bran and germ has been removed, they can starve to death eating the stuff.

We are hit hundreds of times a day with food propaganda from the Generals — General Foods® and General Mills® — convincing us to eat their foods. So we dutifully buy TV dinners, white bread, white rice, boxed and canned foods, and drink billions of cans of soda and beer. We buy potato chips, corn chips, and pre-popped popcorn. We buy sugar-coated cereal. We buy what we acknowledge as junk food from McDonald's®, Dunkin' Donuts®, Pizza Hut®, and the good old Colonel.

The result is that 50% of us have heart attacks. This is a bonanza for the medical profession. They're performing over 400,000 bypass operations a year, knowing full well that 50% of the people will clog up again within five years.

So we have apple pie and ice cream as our national dish. The pie crust is soaked with saturated fat (lard or shortening). The filling has some very dead apples soaked in a congealed sugar goo. And the ice cream is made of fat and sugar. *Bon appétit!*

It's sugar, white flour, and other refined and processed foods which are making us sick and killing us years ahead of our time. They're the reason that 90% of us would never be able to pay our health care bills without the help of our employers and the government. What a racket!

For breakfast we have coffee and Danish, neither of which is providing any nourishment for our bodies. Then we eat a stack of pancakes with maple syrup. Nothing healthy there, either.

Then, all day long we drink Coke and Pepsi®, each with about 10 teaspoons of sugar in them. Or much worse, diet Pepsi or Coke with aspartame for sweetener.

The president of Coca-Cola® in 1993 made over \$4 million, the president of Pepsi made over \$11 million, and the president of Budweiser® made \$13 million, all for making products that you can't stop drinking and which are taking years off your life. And not only here in the US. I was reading about a town of 6,000 in Mexico that averages 4,000 cans of Coke a day!

If you look at the ingredients label on packaged foods you'll see that sugar is high on the list of many, if not most. In 1994 we averaged 150 pounds of sugar per capita! That's about 600 calories per day per person! No wonder we're a fat, constipated, sick people.

Yes, I know — I've been eating candy too. Well, we have a Lindt™ factory here in New Hampshire and there's a Lindt store in nearby Keene — and Lindt chocolate is the best in the whole world. Wow, is it good! So I know how hard it is to give up

Continued on page 85

LETTERS

continued from page 7

copper that went onto the cathode. All but the coin electrodes lost about the theoretical amount, but what they lost remained either in the cotton pads or as a crust of insoluble salt on the anode. The loss of weight from the coin anodes was well under theoretical. These tests did not indicate whether any ions would actually pass through the skin, but the evidence looks slight. Even the tiny amount of copper that went through the pad represents an amount equivalent to several years of usage with the five microamps of unbalanced current.

But I had an even simpler circuit in mind, one using a 4047 CMOS multivibrator that has complemented outputs, which automatically provide an exactly balanced output, even though it probably isn't needed. The circuit here shows how this IC is used. The total current will be under three milliamperes, way below my estimate of 17 mA for Miller's latest circuit. Timing is done with a single resistor and capacitor, providing 6.9 Hz with the values shown. The base resistors are not critical; I have had success with values from 10 k to 20 k. The 33 k resistors on the transistor collectors may be lowered if you want more current,

such as 22 k in Miller's latest circuit. Miller said his original circuit had spikes on the output transitions that burned some people, but neither of mine show any spikes. If you worry about this you can put a small capacitor across the output leads. The 0.1 pF shown gives well-rounded transitions. If you build this you can use your own circuit building judgment or follow Miller's guidelines for his circuit. I like printed circuit boards, and this one is easy to make. I used a 2- x 3-inch scrap of PCB to give lots of room. I use a fine artist's brush to draw the pattern, using tinted shellac (methylene blue in regular shellac, for example). Be generous with the shellac. After it is well dried I etch it in ferric chloride solution, clean it with alcohol and burnish with Comet™ cleanser. Then drill and wire it. Otherwise you can use prototype boards from Radio Shack™.

Antonio Anzevino WB2KDE. Your December 1997 "Never Say Die" column was as great as ever. I especially liked your short article on Dr. Takahashi's magnet powered motor scooter. It's unfortunate that your article was so short in its description of Dr. Takahashi's motor's principal operating theory, other

than "it works." An article on this would be of extreme interest to the technical readers of your magazine. How about a follow-up article on this magnetic motor, including some sources, where one can write to, for further specific information and details.

Magnet motors in 73? Well, why not? So get busy and do some research and tell the rest of us how and why these darned things work. I sure don't understand it, and I've seen the patent. Look up #5,436,518 (1995) and 5,030,867 (1991). Contact Takeo Sawai at Sciex Ltd., 20 Hocroft Road, London NW2 2BL for more information. I think they may finally be starting production on the scooters. Also, Joe Newman has been demonstrating a similar magnet powered motor for some years. Try him at Route 1, Box 52, Lucedale MS 39452 (601-947-7147) ... Wayne.

Jim Parker ABØEZ. I just finished digging out my 30-foot driveway from three feet of snow. No, I didn't use a snow blower, just good old armstrong. I'd like to see some of you fatty, beer-swilling, cigarette-sucking hams do that at 6500 feet above sea level. After doing a lot of thinking I have an answer for

why we let dentists poison us with mercury fillings; why we keep reelecting the same old crooks to Congress; what is our Rocky Mountain ARRL representative doing to increase public awareness of the heroic efforts local hams put in to help people out during the October 1997 blizzard (or is this just another opportunity to increase our ranks lost? After all, we don't want any new hams to increase the QRM on 20 m, do we?); why, after 10-plus years, are the majority of packet nodes still creeping along at 1200 baud; why do we Americans prefer to take a bunch of pills instead of changing our lifestyle habits; why do we blindly take what our doctors say as cast in concrete and not ask questions; why do we, as hams, let the League continue to whittle away at our numbers without doing anything; why do we let the League insist on keeping CW as a rite of passage (or hazing) to get on our HF bands? The answer, Wayne, is very simple: Baa, baa. For the record, I'm an Extra Class ham and a VE. I love CW, but that is my own personal choice. Now that I'm a known troublemaker, I'll probably get flame mail from the good old boys. I'll be happy to answer every one [Jim Parker@bewellnet.com].

73

Adventures in Regulation

continued from page 65

the collector current rarely exceeds 20 mA. However, transistors with the lowest saturation resistance provide the lowest control voltage value. A potentiometer is still used for voltage control, but the value range is 0-5 k for a regulated output voltage range of 5-30 V.

Notes

The following are some cautions to be observed when using three-lead regulators:

(1) The maximum input-to-

output voltage for the selected regulator (typically 35 volts) must not be exceeded. When used in a variable voltage application, the largest differential between the input and the lowest controlled output creates the greatest heat dissipation at a given output current value. Therefore, it is desirable to operate the supply voltage at the lowest possible value in order to achieve a low device dissipation, but high enough to provide the desired regulator function. The regulator will require a minimum headroom differential

value of about five volts to keep it regulating.

(2) The output current of the selected regulator should not be exceeded, even though some regulator types will have an internal current-limiting feature for protection.

(3) A suitable heat sink must be provided to dissipate device heat. The maximum amount of heat to be dissipated can be calculated by multiplying the maximum voltage differential (input voltage minus the lowest output voltage) by the maximum current (typically 1.5 amps). Thermal grease

must be used between the device and the heatsink for best heat transfer.

(4) A reverse-biased diode must be placed across the regulator to protect it from a reverse polarity situation. A series pass regulator must be protected from any reverse voltage exceeding one volt.

(5) The typical input and output capacitor filtering, etc., for the regulator must be provided even though not shown in the figures. The figures are intended only to show the methods for controlling the output voltage value.

73

SPECIAL EVENTS

continued from page 36

AUG 8

HUNTINGTON, WV The Tri-State Amateur Radio Assn. (TARA) will hold their hamfest at the Huntington Memorial Fieldhouse at 2590 5th Ave. For more information call *Bernie Mays* at (304) 743-5459, or E-mail to [wb8zer@juno.com].

SPECIAL EVENT STATIONS

APR 18

WHEATON, IL In commemoration of the 50th anniversary of the club, Wheaton Community Radio Amateurs will operate W9CCU 0200Z-2000Z, on or near 3.880, 7.280, 14.280, and 21.380. QSL with a 9-inch x 12-inch SASE to *Ron Hensel K9ZZE, 43W275 Hawkeye Dr., Elburn IL 60119 USA.*

WILMINGTON, NC The Azalea Coast ARC will operate AC4RC, 1500Z-2100Z, from the original radio room of the Battleship *USS North Carolina BB 55.* Connect with them on 7.250, 14.250, 21.35 and 28.400. QSL AC4RC, P.O. Box 4044, Wilmington NC 28406 USA.

APR 24-25

THOMASVILLE, GA The Thomasville ARC will operate W4UCJ 1700-2300Z April 24th, and 1100-2000 Z April 25th, to commemorate the 77th Annual Rose Festival. Operation will be in the lower portion of the General 80, 40, 20, and 15 meter phone subbands, and the Novice 10 meter phone subband. For a certificate, send your QSL and a 9-inch x 12-inch SASE to *TARC/Rose Festival Station, P.O. Box 251, Thomasville GA 31799 USA.*

APR 24-26

ALBUQUERQUE, NM Station N4C will be operated Apr. 24th 2200 UTC-Apr. 26th 1700 UTC to commemorate the Four Corners State Boundary that is shared by the states of Arizona, Colorado, New Mexico, and Utah (USA). This event will coincide with the NorCal QRP Club's "QRP-to-the-Field '98," where the theme is "Run to the Borders." Updated info

will be posted to [http://www.swcp.com/~n5zgt/]. E-mail queries to [wa5whn@rt66.com] for further info. Please QSL with a business-size SASE to *N4C, c/o Jay Miller WA5WHN, P.O. Box 6552, Albuquerque NM 87197-6552 USA.*

MAY 2-3

1998 CONNECTICUT QSO PARTY The Connecticut QSO Party, sponsored by the Candlewood ARA, will operate 2000Z May 2nd-2000Z May 3rd, with a rest period 0400-1200Z. Phone, RTTY and CW. CW-40 kHz up from lower band edges; Novices 25 kHz up from low end; phone-1.860, 3.915, 7.280, 14.280, 21.380 and 28.380. VHF-50.150, 144.200, and 146.580. RTTY-normal RTTY bands. All bands (HF, VHF, UHF) except WARC bands count. For rules and info, please contact *CARA, P.O. Box 3441, Danbury CT 06813-3441 USA.* Remember to enclose an SASE. Send entry and SASE for results by June 3rd.

MAY 9-10

OREGON QSO PARTY The Central Oregon DX Club, K7ZZZ, will sponsor the 1998 Oregon QSO Party 0000Z May 9th-2400Z May 10th. Suggested frequencies: CW-1.810, 3.540, 3.735, 7.035, 7.125, 14.035, 21.035, 21.125, 28.035 and 28.125. Phone-1.855, 3.905, 7.280, 14.280, 21.380, 28.580. VHF-50.125, 145.025, and 146.550. No repeater QSOs. Awards logs by June 30th to *Oregon QSO Party, c/o C.O.D.X.C. K7ZZZ, 19821 Ponderosa St., Bend OR 97702 USA.* Please contact this address for rules and enclose an SASE. 73

NEVER SAY DIE

continued from page 83

sugar. Oh, I weaned myself from sugar in my coffee after reading the Melvin Page book. And sugar on my All-Bran[®] too. But then there's that 13-ounce bar of Lindt milk chocolate that Sherry gave me for Christmas. Sigh.

Over 40 years ago I read a great book by Dr. Melvin Page, who had researched the damage that sugar was doing to us. I've written about this

HOMING IN

continued from page 79

The processor will send the call sign presently in data memory in slow CW. Set S1-1 to S1-8 for the binary code representing the first character of your call sign, then press the LOAD A LETTER button (S2). Repeat for the remaining characters of the call sign. The unit sends the character in CW when S2 is pressed, for verification. Now set S1-1 through S1-8 to 11111111 (End of Message) and press S2. Set S1-1 through S1-9 for the start delay, fox number and number of foxes, remove jumper JP1 and press S3.

An automatic shutoff is included in the program to stop transmissions after four hours. This feature is used in European hunts to signal the end of a practice session. It also prevents complete discharge of the fox

batteries if the box isn't recovered immediately. Shutoff time cannot be programmed in the field. If you anticipate very long hunts, you can change the shutoff timer values in the source code and reprogram your PIC.

Plan some hunts now

Spring is here, so your club should be scheduling its warm weather foxhunting activities. Since announcement of its formation was made in "Homing In" for January, the North American ARDF Organizing Task Force has received inquiries from many hams in the USA and Canada about plans for national and international foxhunting championships. We want to hear about activities in your area, too. To become an ARDF Point of Contact for your locality, please send E-mail or postal mail to me. 73

book many times during my last 40 years or so of editorials, and it's still being quoted by current authors in the field.

If you bother to read anything about how the body processes food and uses it, you'll understand the enormous damage that sugar is doing to you and your family. And that includes jam, jellies, honey and syrups. Most of us are seriously addicted to sugar. If you think I'm exaggerating just try for one week to stop eating anything with sugar in it. Good luck.

There are at least two inexpensive books that you *must* read. Please don't let your usual procrastination stop you on this. Call (800) 243-1438 and order (#5745) *Lick The Sugar Habit*, and (#5880) *Beating The Food Giants*. They're \$6 and \$10 respectively, plus \$3 s/h. That's the number for Radio Bookstore in Seattle. No relation to Radio Bookshop.

Once you find out the part that sugar plays in heart disease, diabetes, and a host of other awful diseases, maybe you'll be able to kick the

habit, too.

So watch out for the stuff those Generals are pushing you to eat. Colonels too. The major problem is that it'll damage your body. Are you the captain of your fate or is the media? A good basic rule: If it's advertised on TV, don't eat it!

EMF Damage

A note in *Time* magazine said that women who use an electric blanket at the time of conception or in early pregnancy have a 75% greater chance of having a spontaneous abortion. It seems to me I wrote about this hazard several years ago and got hoots of disbelief from a bunch of readers.

But how come the doctors doing this research haven't figured out that if the alternating current magnetic field from an electric blanket can increase spontaneous abortions so significantly, that this field is also going to affect to some degree any cell growth it impacts? Suppose the screwing

Continued on page 86

QRX

continued from page 9

is this: All electronic devices—and especially ICs—work on smoke.

Yes, that's what I said: Smoke! I have recently discovered that every electronic device manufacturer and all IC makers encapsulate a certain amount of black smoke in every one of their devices. This smoke is what does the work and performs the magic of electron flow inside the device.

Undoubtedly, you have often noticed that a component will quit working when this encapsulated smoke leaks out. I have documented this many times, and it conclusively proves my theory. After all, when a storm comes up, the sky gets black. The lightning starts to flash through the black clouds, which must be smoke. But when the smoke is gone and the sky clears and is no longer black, the lightning stops!

So, the smoke is the answer to electron flow. Proof positive: Have you ever been able to operate an electronic component after the smoke has leaked out? I rest my case ...

Author unknown, but found on the Web by and reprinted in *Static*, newsletter of the North Hills Amateur Radio Club, Pittsburgh PA (September 1997).

When CW Is Seen and Not Heard

It turns out that I was exposed to CW most evenings for about the first 20 years of my life. That didn't really hit me until the other night.

The house I grew up in is located in the Hollywood Hills, and has a beautiful view of the city. The Capitol Records building can be seen from almost any window in the house. It looks like a record player with a tall needle on top. That needle has a blinking red light, just like any other tall structure.

I remember my parents telling me that the blinking light spells out "Hollywood" in Morse code. I do remember watching the light as I was growing up and noticing that the blinking was not regular, but it never occurred to me that one day I might be able to confirm what I had been told.

I took my kids to Los Angeles to visit my family last week, and on the last night of our stay, I found myself gazing out the window during dinner. All of a sudden I remembered what I had been told about the light on the Capitol Records building, and I realized that I could actually test the claim. It took me a minute to get a feel for the dits and dahs, since the sending speed is quite slow (about 1 wpm?!). Then, I said to my parents, "I think that was a D." Finally, after a pause, I copied H, O, L, L, etc. That blinking light does indeed spell "Hollywood" in CW!

This probably sounds like quite a minor accomplishment, but it struck me that although I had seen that blinking light for much of my life, only now have I been able to "hear" it. It's like the

feeling you get when you learn a foreign language, and then you can't remember what it was like to not be able to understand those words. It's the same way with CW. I don't think I'll ever be able to look at the Capitol Records building the same way again.

Now, if my kids would only give me the time to copy something other than a blinking red light spelling "Hollywood" ...

TNX Kelly Fast N3XUJ and *The Ham Arundel News* (Anne Arundel Radio Club), December 1997. 73

NEVER SAY DIE

continued from page 85

up of cell growth in the fetus is such that it isn't enough to bring about a spontaneous abortion? It may not even affect cell growth in areas that will be clearly visible as deformities in the child. But the normal cell development will be affected, so the child is not going to have the full benefit of the DNA plans inherited from the parents. The result may be a sociopath, subtle retardation, some weak organs and a predisposition to some illnesses. It's a crap shoot, with no possible winners, just various magnitudes of loss.

The magnetic field from an electric blanket will act the strongest on fast-growing cells — like those in babies and children, which explains why so many children living or going to school in high-magnetic field environments get leukemia. But it also explains why adults get cancer and tumors in the same fields. The cell division and growth may be slower in adults, but it's going on all the time and plenty of misery can come from cell growth which has been screwed up by an alternating-current magnetic field.

So throw out your electric blankets and bundle up with blankets and a comforter.

We need to learn a lot more about the effects of steady magnetic fields on plant and animal growth, as well as alternating frequency fields of different frequencies. Anyone willing to spend a few minutes setting up an experiment on the kitchen windowsill with seeds in identical dirt, some with the north pole of a magnet under them, others with a south pole, and a control group with no magnet will see the incredible difference this makes in just a few days. It's a little more difficult to set up the experiment with an alternating field below the seeds, but wait'll you see what results when you do! Scrambled genes.

I spent years being toasty under an electric blanket — until I started reading about the damage that EMFs could do. I then got a milligauss meter and checked my electric blanket. Wow! That was the last day I used it.

Well, all unwell and bad for 60 Hz fields, but how about cell phones? Maybe you read recently about the Australian doctor who did a study on this and reported a 50% increase in brain tumors for cell phone users. That's something to think about the next time you put an HT near your head. It also confirms the research published by Dr. Ross Adey K6UI, the leading expert in the field.

The power and radio industries are in denial, of course. Why does that remind me of the tobacco executives swearing to that congressional committee that cigarettes are not harmful. And before that the asbestos industry played the same record. All the studies are flawed, they claimed. Sure.

Pulsing

A letter from Rudi Mangold HB9DU/W6 discussed his use of high-energy pulses to kill viruses and bacteria in water. Anyone know more about that? It might be better than pasteurization for milk, if it doesn't change the taste. Rudi also said that high-energy pulses will disintegrate stones and even a refrigerator in a water tank. The tank is the positive pole and then a thick stainless steel pole is put into the water a little above the object to be disintegrated and a nanosecond negative pulse of energy is used. Rudi says he's using 250,000 volts at 6,000 amperes. Good grief, that's 1,500 megawatts! But in nanosecond pulses for two or three nanoseconds, so the average power needed is relatively small. The resulting powder can then be separated using normal flotation methods. This might be an inexpensive system for separating gold from ore. I hope that Rudi will be able to get an experimental pilot plant built — and invite me to see it.

There are so many potential areas open for inventing and pioneering that the mind boggles. But, I wonder, is there *anything* that will get you out of your rut? My grandfather was an inventor, so perhaps I inherited something from him. His inventions founded what you now know as Citgo™. My father was an aviation pioneer — pilot's license #73, by coincidence. 73

Wanted

Fun, easy to build projects for publication in 73.

For more information, write to:

Joyce Sawtelle

73 *Amateur Radio Today*

70 Route 202 North

Peterborough NH 03458

PROPAGATION

Jim Gray W1XU
210 E. Chateau Circle
Payson AZ 85541
[jimpeg@netzone.com]

There is evidence that the HF bands are finally "waking up" and solar flux levels have begun their long-expected steady climb. However, operating conditions this month could be erratic — typical of the spring equinox and also the beginning of a new sunspot cycle.

The ionosphere from about April 7th–12th is likely to be very disturbed, accompanied by high signal absorption (A and K indexes high) and poor or non-existent DX on near-polar transmission paths. In contrast, transequatorial paths could be useful during the same period.

Possibly severe weather and other geophysical upsets are likely on the days surrounding the 9th and 10th, but increased activity is likely on the VHF bands at the same time.

10–12 meters

Generally Poor, except for occasional transequatorial propagation with F2 openings on the best days—most likely South and Central America.

15–17 meters

DX to Africa and Latin America on the Good days possible, with short-skip out to about 1,000 miles or so in the US.

20 meters

Your best band for DX openings around the world from dawn to dark, and openings to the Southern Hemisphere after dark in evening hours. You can expect excellent short-skip during the daytime to 2,500 miles or so.

30–40 meters

These bands ought to be open for DX from just before sunset to just after sunrise. Signals from the east should peak until midnight, and after midnight to other areas. Daylight short-skip of about 500 miles will be possible, and nighttime short-skip to 1,500 miles or more will be available.

80 meters

Occasional DX to various areas of the world should be possible between sunset and sunrise when QRN levels permit on Good (G) days (see calendar). Short-skip during darkness to 1,500 miles or more.

APRIL 1998						
SUN	MON	TUE	WED	THU	FRI	SAT
			1 G	2 G	3 G-F	4 F-P
5 P-F	6 F-P	7 P	8 P-VP	9 VP	10 VP-P	11 P
12 P	13 P-F	14 F	15 F-G	16 G	17 G-F	18 F
19 F-P	20 P-F	21 F	22 F-G	23 G	24 G-F	25 F
26 F-G	27 G	28 G	29 G	30 G		

160 meters

This band ought to begin to come alive again during the hours of darkness when QRN permits. Try the days marked G on the calendar for best results. DX toward the east until midnight, and to other areas afterwards until dawn. Short-skip to

1,500 miles will prevail when the band is quiet.

Note about chart: The indicated band is only a guide. Always check the next higher or lower band. Where 10 meters is shown, listen on 12; where 15 meters is indicated, listen on 12 and 17; and so forth.

73

EASTERN UNITED STATES TO:												
GMT:	00	02	04	06	08	10	12	14	16	18	20	22
ALASKA	14	14	7	7	7	7	7	7	14	14	14	14
ARGENTINA	21	14	14	7	7	7	7	14	14	21	21	21
AUSTRALIA	21	14	7	7	7	7	7	7	7	7	14	14
CANAL ZONE	14	14	7	7	7	7	7	14	14	14	21	21
ENGLAND	14	7	7	7	7	7	14	14	14	14	14	14
HAWAII	21	14	14	7	7	7	7	7	14	14	14	21
INDIA	14	14	7	7	7	7	7	14	14	14	14	14
JAPAN	14	14	14	7	7	7	7	7	14	14	14	14
MEXICO	14	14	7	7	7	7	7	14	14	14	14	14
PHILIPPINES	14	14	14	7	7	7	7	14	14	14	14	14
PUERTO RICO	14	14	7	7	7	7	14	14	14	14	14	14
RUSSIA (C.I.S.)	7	7	7	7	7	7	14	14	14	14	14	14
SOUTH AFRICA	7	7	7	7	7	14	14	14	14	14	14	14
WEST COAST	14	14	14	7	7	7	7	14	14	14	14	14

CENTRAL UNITED STATES TO:												
GMT:	00	02	04	06	08	10	12	14	16	18	20	22
ALASKA	14	14	14	7	7	7	7	7	7	14	14	14
ARGENTINA	21	14	14	7	7	7	7	14	14	21	21	21
AUSTRALIA	21	14	7	7	7	7	7	7	7	7	14	14
CANAL ZONE	21	14	7	7	7	7	7	14	14	14	21	21
ENGLAND	14	7	7	7	7	7	7	14	14	14	14	14
HAWAII	21	14	14	7	7	7	7	7	14	14	14	21
INDIA	14	14	7	7	7	7	7	7	14	14	14	14
JAPAN	14	14	14	7	7	7	7	7	14	14	14	14
MEXICO	14	14	7	7	7	7	7	7	14	14	14	14
PHILIPPINES	14	14	14	7	7	7	7	14	14	14	14	14
PUERTO RICO	14	14	14	7	7	7	14	14	14	14	14	14
RUSSIA (C.I.S.)	7	7	7	7	7	7	14	14	14	14	14	14
SOUTH AFRICA	7	7	7	7	7	7	14	14	14	14	14	14

WESTERN UNITED STATES TO:												
GMT:	00	02	04	06	08	10	12	14	16	18	20	22
ALASKA	14	14	7	7	7	7	7	7	14	14	14	14
ARGENTINA	21	14	14	14	7	7	7	14	21	21	21	21
AUSTRALIA	21	14	14	14	7	7	7	7	7	7	14	21
CANAL ZONE	21	14	7	7	7	7	7	14	14	14	21	21
ENGLAND	14	7	7	7	7	7	7	7	14	14	14	14
HAWAII	21	14	14	14	7	7	7	7	14	14	21	21
INDIA	14	14	14	7	7	7	7	7	14	14	14	14
JAPAN	14	14	14	14	14	7	7	7	14	14	14	14
MEXICO	14	14	7	7	7	7	7	14	14	14	14	14
PHILIPPINES	14	14	14	14	14	7	7	14	14	14	14	14
PUERTO RICO	14	14	7	7	7	7	7	14	14	14	14	14
RUSSIA (C.I.S.)	7	7	7	7	7	7	7	14	14	14	14	14
SOUTH AFRICA	7	7	7	7	7	7	7	14	14	14	14	14
EAST COAST	14	14	14	7	7	7	7	14	14	14	14	14

UPDATES

Just a little stutter ...

In March's ID-8 review, the ZIP code for Communications Specialists has an extra "6" in the middle. The correct mailing address should read:

Communications Specialists, Inc.
426 West Taft Avenue
Orange CA 92865-4296. 73

Save 47%!
on 12 months of 73
Only \$24.97
Call 800-274-7373
or
Fax 603-924-8613

Barter 'n' Buy

Turn your old ham and computer gear into cash now. Sure, you can wait for a hamfest to try and dump it, but you know you'll get a far more realistic price if you have it out where 100,000 active ham potential buyers can see it, rather than the few hundred local hams who come by a flea market table. Check your attic, garage, cellar and closet shelves and get cash for your ham and computer gear before it's too old to sell. You know you're not going to use it again, so why leave it for your widow to throw out? That stuff isn't getting any younger!

The 73 Flea Market, Barter 'n' Buy, costs you peanuts (almost)—comes to 35 cents a word for individual (noncommercial!) ads and \$1.00 a word for commercial ads. Don't plan on telling a long story. Use abbreviations, cram it in. But be honest. There are plenty of hams who love to fix things, so if it doesn't work, say so. Make your list, count the words, including your call, address and phone number. Include a check or your credit card number and expiration. If you're placing a commercial ad, include an additional phone number, separate from your ad.

This is a monthly magazine, not a daily newspaper, so figure a couple months before the action starts; then be prepared. If you get too many calls, you priced it low. If you don't get many calls, too high.

So get busy. Blow the dust off, check everything out, make sure it still works right and maybe you can help make a ham newcomer or retired old timer happy with that rig you're not using now. Or you might get busy on your computer and put together a list of small gear/parts to send to those interested?

Send your ads and payment to: **73 Magazine, Barter 'n' Buy, 70 Rt. 202N, Peterborough NH 03458** and get set for the phone calls. The deadline for the July 1998 classified ad section is May 10th, 1998.

MMDS DOWNCONVERTERS Drake Model 2880, \$58.95. 2.4 GHz parabolic antennas, \$89.95. For more information, send SASE to: **Hudson Technologies**, P.O. Box 552, Caldwell ID 83606-0552. BNB917

Cash for Collins: Buy any Collins Equipment. **Leo KJ6HI**, Tel./FAX (310) 670-6969, [radioleo@earthlink.net]. BNB425

RF TRANSISTORS TUBES 2SC2879, 2SC1971, 2SC1972, MRF247, MRF455, MB8719, 2SC1307, 2SC2029, MRF454, 2SC3133, 4CX250B, 12DQ6, 6KG6A, etc. **WESTGATE**, 1-800-213-4563. BNB6000

TIRED OF IRONING? PCB service. No \$ setup, free scanning available. **FIRST PROTO**, 4201 University Drive, #102, Durham NC 27707. (919) 403-8243. BNB5005

HIGH END SUBWOOFER AMPS, ALUMINUM CONES, OTHER AUDIO STUFF. Burnett Associates. (603) 924-2383. FAX (603) 924-3392. [FDTF77B@prodigy.com]. BNB999

ASTRON power supply, brand-new w/ warranty, RS20M \$99, RS35M \$145, RS50M \$209, RS70M \$249, **AVT**. Call for other models. (626) 286-0118. BNB411



ISN'T THAT AMUSING? I'LL BET YOUR SUITCASE IS A REAL RIOT !!

TELEGRAPH KEYS AT DAYTON HAMFEST: 500+ Pre-Civil War-WWII Historic Antique Telegraph Keys. Bring your OLD keys, photos, stories. Free Information, History, Appraisals, Pretzels! Collectors' Show-'n'-Tell Party. I'll be Buying, Trading, Selling. **Tom Perera W1TP**. Visit my Internet telegraph museum for previews and hamfest location: [http://www.chss.montclair.edu/~pererat/telegraph.html]. BNB890

WANTED: RF Installation Technician—Future Vision, Inc. is seeking individuals to install wireless data communication systems throughout the US and Canada. Candidates should have experience installing antennas, transmission lines, grounding systems, and tower climbing. Microwave & spread spectrum experience is a plus! This position includes extensive travel. Please forward résumé and salary requirements to Jim Hong KA8ZGP at [jim@futurevision.net] or by mail: **Future Vision, Inc.**, 1709 N. West Ave., Suite 117, Jackson MI 49202. Future Vision, Inc. is an equal opportunity employer. [www.futurevision.net]. BNB836

COLLOIDAL SILVER GENERATOR! Why buy a "box of batteries" for hundreds of dollars? Current regulated, AC powered, fully assembled with #12 AWG silver electrodes, \$74.50. Same, but DC powered, \$54.50. Add \$2.50 shipping. **Thomas Miller**, 314 South 9th Street, Richmond IN 47374. BNB342

BIOELECTRIFIER™ 5 Hz micro current supply for plant and animal research. Semi-Kit \$38.00. Assembled complete with batteries and silver electrodes \$89.50. Add \$2.50 postage. **Thomas Miller**, 314 South 9th Street, Richmond IN 47374. BNB343

MAHLON LOOMIS, INVENTOR OF RADIO, by Thomas Appleby (copyright 1967). Second printing available from **JOHAN K.V. SVANHOLM N3RF**, SVANHOLM RESEARCH LABORATORIES, P.O. Box 81, Washington DC 20044. Please send \$25.00 donation with \$5.00 for S&H. BNB420

CLASSIC RADIOS. RadioFinder Web list revised weekly: [www.radiofinder.com] Tel/FAX (313) 454-1890, [finder@radiofinder.com]. BNB700

METHOD TO LEARN MORSE CODE FAST AND WITHOUT HANGUPS Johan N3RF. Send \$1.00 & SASE. SVANHOLM RESEARCH LABORATORIES, P.O. Box 81, Washington DC 20044 USA. BNB421

HEATH COMPANY is selling photocopies of most Heathkit manuals. Only authorized source for copyright manuals. **Phone:** (616) 925-5899, 8-4 ET. BNB964

Audio Equipment Wanted: 1930s-1960s. Tube-type amplifiers, large or small speakers, mixers, microphones, tubes, parts, etc. Especially Western Electric, Jensen, Marantz, MacIntosh, JBL, etc. 1-800-251-5454. BNB202

Radio Bookshop ORDER FORM

You may order by mail, telephone, or fax. All payments are to be in US funds. Allow 4 weeks for delivery. (Prices subject to change without notice if suppliers increase prices or new editions cost us more.)

ITEM	TITLE	QTY	PRICE	TOTAL

Shipping: All orders add \$5.00 handling *plus there is an additional at cost shipping charge added to all foreign orders. We ship UPS where possible, please give us street address. **S&H* TOTAL \$**

Make checks payable to "Radio Bookshop."

Foreign Orders: Choose one surface shipping air shipping (Surface delivery may take 2-3 months.)

*Note: The actual foreign shipping costs will be additional to the regular shipping and handling fees.

Name _____ Phone _____

Address _____

City _____ State _____ Zip _____ Country _____

\$10 minimum for credit card orders

Total Paid \$ Check/Money Order AMEX MC VISA

Card # _____ Expires _____

Signature _____ Date _____

Telephone: 603-924-0058, 800-274-7373, FAX 603-924-8613

Mail: Radio Bookshop, Dept. 498, 70 Route 202 N, Peterborough NH 03458

YES, Send me 12 issues of 73 at the low rate of \$24.97 (save 47% over the cover price). Canada add \$7 plus \$1.40 GST; Foreign add \$19 surface; \$42 airmail.

The New Approach to HF Radio!

The Kachina 505DSP Computer Controlled Transceiver

Features:

- Works with any Computer Running Windows 3.1, 95 or NT
- Covers all Amateur HF Bands plus General Coverage Receiver
- IF Stage 16/24 Bit Digital Signal Processing (DSP)
- II DSP Bandpass Filter Widths from 100 Hz to 3.5 kHz (6 kHz in AM Mode)
- Band Activity Display with "Point and Click" Frequency Tuning
- On-screen Antenna "Smith" Chart, Logging Software and Help Menus
- Automatic Frequency Calibration from WWV or Other External Standard
- "Snapshot" Keys for Instant Recall of Frequencies and Settings
- Optional Internal Antenna Tuner

PC not included

The Kachina 505DSP Computer Controlled HF Transceiver After twenty years of building commercial transceivers in Arizona, Kachina has decided the time is right for a new approach to amateur radio. The Kachina 505DSP is nothing short of a revolution in HF transceivers.

Why Use Knobs if You Have Windows? The old-fashioned front panel has become too cluttered to be useful. Too many knobs, too many buttons. Kachina's 505DSP transceiver connects to your computer's serial port and is completely controlled under Windows™. With optional cables, the radio may be remotely located up to 75 feet away from your computer. Imagine combining a state-of-

the-art DSP transceiver with the processing power and graphics capabilities of your PC and you'll soon wonder why all radios aren't designed this way. Why settle for a tiny LCD display when your computer monitor can simultaneously show band activity, antenna impedance, heat sink temperature, SWR, forward and/or reflected power and a host of other information?

16/24 Bit DSP/DDS Performance In addition to 100% computer control, the Kachina 505DSP offers exceptional 16/24 bit DSP/DDS performance. IF stage DSP, "brick-wall" digital filtering, adaptive notch filters and digital noise reduction, combined with low in-band IMD and high signal-to-noise ratio, produce an

excellent sounding receiver. Sophisticated DSP technology achieves performance levels unimaginable in the analog world. The transmitter also benefits from precise 16/24 bit processing. Excellent carrier and opposite-sideband suppression is obtained using superior phasing-method algorithms. The RF compressor will add *lots* of punch to your transmitted signal without adding lots of bandwidth, and the TX equalizer will allow you to tailor your transmitted audio for more highs or lows.

Seeing is Believing

American-made and designed, and able to stand on its own against the world's best, the 505DSP is bound to set the standard for all that follow. But don't take our word for it. Visit our website at <http://www.kachina-az.com> for detailed specifications, to download a demo version of our control software, or to see a current list of Kachina dealers displaying demonstration models in their showrooms.

KACHINA 
COMMUNICATIONS, INC.

P.O. Box 1949, Cottonwood, Arizona 86326, U.S.A.
Fax: (520) 634-8053, Tel: (520) 634-7828
E-Mail: sales@kachina-az.com

Windows is a trademark of Microsoft Corp.
Specifications and features subject to change without notice.



JST-245

160-10 Meters PLUS 6 Meter Transceiver



Fifteen reasons why your next HF transceiver should be a JST-245...

- 1** All-Mode Operation (SSB,CW,AM,AFSK,FM) on all HF amateur bands and 6 meters. JST-145, same as JST-245 but without 6 meters and built-in antenna tuner.
★ JST-145 COMING SOON ★
- 2** MOSFET POWER AMPLIFIER • Final PA utilizes RF MOSFETs to achieve low distortion and high durability. Rated output is 10 to 150 watts on all bands including 6 meters.
- 3** AUTOMATIC ANTENNA TUNER • Auto tuner included as standard equipment. Tuner settings are automatically stored in memory for fast QSY.
- 4** MULTIPLE ANTENNA SELECTION • Three antenna connections are user selectable from front panel. Antenna selection can be stored in memory.
- 5** GENERAL COVERAGE RECEIVER • 100 kHz-30 MHz, plus 48-54 MHz receiver. Electronically tuned front-end filtering, quad-FET mixer and quadruple conversion system (triple conversion for FM) results in excellent dynamic range (>100dB) and 3rd order ICP of +20dBm.
- 6** IF BANDWIDTH FLEXIBILITY • Standard 2.4 kHz filter can be narrowed continuously to 800 Hz with variable Bandwidth Control (BWC). Narrow SSB and CW filters for 2nd and 3rd IF optional.
- 7** QRM SUPPRESSION • Other interference rejection features include Passband Shift (PBS), dual noise blanker, 3-step RF attenuation, IF notch filter, selectable AGC and all-mode squelch.
- 8** NOTCH TRACKING • Once tuned, the IF notch filter will track the offending heterodyne (± 10 KHz) if the VFO frequency is changed.
- 9** DDS PHASE LOCK LOOP SYSTEM • A single-crystal Direct Digital Synthesis system is utilized for very low phase noise.
- 10** CW FEATURES • Full break-in operation, variable CW pitch, built in electronic keyer up to 60 wpm.
- 11** DUAL VFOs • Two separate VFOs for split-frequency operation. Memory registers store most recent VFO frequency, mode, bandwidth and other important parameters for each band.
- 12** 200 MEMORIES • Memory capacity of 200 channels, each of which store frequency, mode, AGC and bandwidth.
- 13** COMPUTER INTERFACE • Built-in RS-232C interface for advanced computer applications.
- 14** ERGONOMIC LAYOUT • Front panel features easy to read color LCD display and thoughtful placement of controls for ease of operation.
- 15** HEAVY-DUTY POWER SUPPLY • Built-in switching power supply with "silent" cooling system designed for continuous transmission at maximum output.



Japan Radio Co., Ltd.

430 Park Ave., 2nd Floor New York, NY 10022 Phone: (212) 355-1180 Fax: (212) 319-5227

CIRCLE 159 ON READER SERVICE CARD