

**Electronics**

**Radio**

**Television**

**Radar**

**UNITED ELECTRONICS LABORATORIES**

LOUISVILLE

KENTUCKY

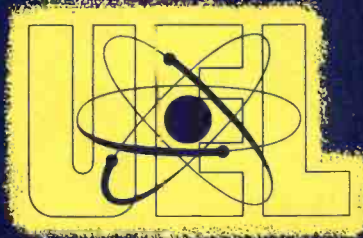

REVISED 1967

COPYRIGHT 1956 UNITED ELECTRONICS LABORATORIES

*X<sub>0</sub> = 1/2000* *X<sub>c</sub> = .159/FC*  
**AN INTRODUCTION TO ELECTRONICS**

**ASSIGNMENT 1**

## **ACKNOWLEDGEMENT**

The preparation of the Electronics information which is included in this Training Program would not have been possible without the help of a large number of organizations and individuals.

In particular, United Electronics Laboratories gratefully acknowledges the cooperation and assistance of the Westinghouse Corporation, the Radio Corporation of America (RCA), the Philco Corporation, Motorola, Incorporated, the General Electric Corporation, the Columbia Broadcasting System, the National Broadcasting Company, Branson Instruments, Inc., Gulton Industries, Inc., the Sperry Gyroscope Company, and International Business Machines Corporation.

# ELECTRONICS TECHNICIAN TRAINING

## ASSIGNMENT 1

### AN INTRODUCTION TO ELECTRONICS

You took possession of a key to one of the most interesting, respected, and well-paid professions in the world when you decided to enter the field of Electronics. Your key to this new world will be your knowledge of electronics—how electronics equipment operates, how defective parts affect this equipment, how to repair and maintain it. This knowledge will enable you to service, operate, and maintain the wide variety of electronics, television, and radio equipment which play such a vital part in our present-day civilization.

Perhaps you've heard the old saying, "Life is hard by the yard, but a cinch by the inch." This is also true regarding electronics. You may, in the back of your mind, have a vague, uneasy feeling because you're afraid electronics may be too hard for you. This would probably be true if you were confronted with an electronics job today. However, it is **not** true regarding this electronics training program. For you, this training program should be a "cinch by the inch." You will learn what you need to know in the electronics field **a little at a time**. This will make it possible for you to advance in a step-by-step method to reach your goal as an electronics technician. The UEL training program has been successful in enabling great numbers of other men to become electronics technicians, and you can be assured that the training program will **also do the job for you**.

In the past few years the field of electronics has grown more rapidly than any other industry has ever grown in the history of the world! Opportunities are available for electronics technicians in many fields: missiles, computers, radar, radio-TV broadcasting, electronics service shops, industrial electronics, automation—to mention but a few. It is the purpose of this first assignment in the training program to introduce you to the electronics field and to show you the close relationship between the various branches of the electronics field, radio and television.

### History of Communication

Since the days of the stone age, man has tried to send messages over ever-increasing distances. The first "long distance transmission" was probably a shout. However, the primitive man soon learned that greater distances could be spanned by beating on a hollow log with a club. In some primitive tribes, even today, this system of communication is still employed.

Of course, the use of sound is not the only method of communication. The sense of sight has also been used since the time of the cave man for sending information from one point to another. As the cave man waved his hand in a greeting to his fellow creature on the other side of the valley, he was using this method of communication. As time passed, sight communication was improved through the use of puffs of smoke, lanterns, fires, and

the waving of flags. Some of these systems, too, are still employed in modern communications—for example, the landing signal flags used aboard aircraft carriers.

All of the methods of communication which have been mentioned so far have the same fault in common. The distance over which they are effective is quite limited—up to a few miles, at best.

Although man yearned for long distance communication for thousands of years, it was not until less than 150 years ago that an important step forward was made. In 1832, when Samuel F. B. Morse invented the electric telegraph, the distance of communication was extended “beyond the horizon.” By operating a telegraph key, he controlled the flow of electrical impulses along a wire, which caused a telegraph “sounder” at the other end of the wire to operate, producing clicks which could be heard. By means of code, these clicks could be translated into letters and words. The growth of the telegraph was rapid, and in approximately 30 years telegraph messages were being sent from America to Europe by means of an undersea cable.

The next stride forward in communications took place in 1875, when Alexander Graham Bell invented the telephone. In this device electricity was again used, but a reproduction of the speaker’s voice, rather than the clicking of a sounder, was heard at the opposite end of the line. Thus, a spoken message could be sent over hundreds of miles.

Although the telegraph and the telephone could carry messages over hundreds of miles, they were both limited in the same way. They could carry these messages **only where it was possible to string wires**. Thus, it was not possible to communicate with remote areas, with ships at sea, with balloons, or, a little later, with airplanes. A means of communication was needed which did not require the use of wires—in other words, **wireless telegraph and wireless telephone**.

A few years after the invention of the telephone, a young German scientist, Heinrich Hertz, experimented with the first form of wireless telegraph. He sent radio waves and picked them up across the room with a very crude receiver. Many other scientists and experimenters worked in the development of Hertz’s crude “wireless” telegraph system, and shortly after the turn of the century Guglielmo Marconi succeeded in sending the first message across the Atlantic Ocean by means of radio waves. Development of the radio system resulted in wireless telephone communication, which led to radio broadcasting, as it is known today. So, communication over thousands of miles without wires became a reality and helped make possible many other scientific developments of the Twentieth Century.

Miraculous as it is, radio did not fully satisfy the needs of the general public. Because we are gifted with sight, it is only natural for us to want to see as well as hear our entertainment. Consequently, while some scientists and inventors worked to improve radio, others were working just as hard to develop a system whereby pictures could be “transmitted through space.” This system is, of course, **TELEVISION**.

It might be well to point out that television is not the result of any one person's work or creative genius. Instead, it represents the work of many scientists, inventors, and experimenters. The first television pictures were transmitted from Whippany, New Jersey, to New York City, by Dr. Herbert Ives, in 1927. These were very poor images, and it was not until 1946 that television transmitting equipment and receivers were perfected enough to make commercial black-and-white television broadcasting practical.

Color television also passed through a long period of development before its final acceptance. The first color television pictures were transmitted by Dr. Ives and his associates in 1929. These pictures were small and relatively crude. Many systems were devised to enable larger color television pictures to be telecast, but it was not until 1953 that a truly suitable color television system was available to the general public.

Thus, in a span of less than 150 years, man was able to accomplish what he had dreamed about for thousands of years—the transmission of sound and sight (in full color) over long distances. Color television is the fulfillment of that dream.

### **Electronics Fulfills Other Dreams**

Man has had other age-long dreams which electronics has helped to fulfill. The desire to "fly like a bird" was partially satisfied with the invention of the airplane but it required the application of electronics to this field in the form of radio communication equipment, automatic pilots, air-navigation systems, radar landing systems, and other such devices to bring air travel to its present state of safety.

Man's even more fantastic dream of traveling in space would be absolutely impossible without electronics. Missiles travel at such high speeds that they cannot rely on a human "pilot" for control. They must, instead be controlled by an electronic computer or electronic brain, which has been supplied beforehand with all the necessary information regarding the planned flight path. In fact, electronics plays a **vital part** in the missile program, and a major portion of the research effort in this field is devoted to developing the electronics equipment and instruments used for launching, controlling, and tracking the missiles.

Since man started to labor in the factory and plant, he has yearned for a machine which would do his work for him. This has led to **automation, which is the control of industrial processes by means of electronic equipment.** Figure 1 shows a photograph of the control instruments at Petroleum Chemicals, Inc., at Lake Charles, Louisiana. These instruments and their associated circuits control practically all the chemical processes in this huge plant.

Man has also had a desire to have more and more power at his fingertips. The horse was replaced by the steam engine and the gasoline engine. Jet and rocket power followed and the ultimate—atomic power—has been reached, although it has not been fully developed. Atomic power, like missile flight, is too critical to be controlled strictly by human means. Electronics, once again, "takes over," as it is able to control atomic processes much more accurately and much more quickly than would a human operator.

This gives us a rather broad view of the important role electronics plays in the complex world in which we now live. Let us now look more closely at some of the parts, or divisions, of the electronics field. As a starting point we'll first consider radio, as radio is the father of the entire electronics family.

## **Radio Broadcasting**

When we hear someone speak of radio, we naturally think of radio broadcasting, since this field is familiar to all. Although the radio broadcasting field is important, it actually represents only a very small portion of the over-all field of radio and communications.

In the ordinary usage of the term, radio broadcasting suggests the broadcasting of entertainment, news, etc., for the benefit of the general public. There are several ways in which this is done. The first of these, and the most widely known, occurs in the "Standard Broadcast Band" which is received by millions of home and auto radio receivers.

There are also short-wave radio broadcast stations which are used to broadcast entertainment from stations in this country to other points throughout the world. These stations are small in number compared to the standard broadcast stations.

Another radio broadcast service is provided by the Frequency Modulated stations. These stations transmit entertainment and operate on the short waves, but, as they operate on an entirely different principle than the short-wave broadcast service which has been mentioned, the programs are not "carried" great distances. Instead, each station serves an area close around it, within a radius of approximately 50 miles.

## **Two-Way Communications**

Almost all police forces now have two-way radio equipment to provide communication between the headquarters and the patrol cars out on the streets or country highways. The patrolmen in the cars are able to talk to headquarters and usually to each other.

All commercial aircraft and many private aircraft are equipped with two-way radio communication equipment. This enables the pilot to receive weather reports, landing instructions, etc., from ground stations during flight, and it also permits the pilot to report his position at regular intervals. Figure 2 shows just a small part of the radio equipment aboard a commercial aircraft.

Two-way radio communications systems are now being used by hundreds of different services and industries. Among these are: taxicabs; busses; truck lines; water, gas, and electric utility companies; railroads; garage and wrecker services; road maintenance departments; pipelines; and delivery services.

## **Instrument Landing Equipment**

Commercial airliners are equipped with radio devices to enable the pilot to land the plane during heavy fog, rain, or other conditions which would make sight landing impossible. In addition, radar equipment is being used in almost all commercial airports.

## **Radio-Beacon Equipment**

This equipment is used to guide planes in the air. The radio waves are concentrated into "beams," and the airplanes fly along these beams, just as a car follows a highway. Other radio signals in the beacon system tell the aircraft pilot when he is a few miles from the airport and when to start his landing glide. This is where we get the expression "we're on the beam."

## **Loran Equipment**

This is a system somewhat similar to the radio-beacon. It is used as a navigational aid for ships at sea.

## **Micro-wave Relay Systems**

Micro-wave relay systems are sometimes used by the Bell Telephone System to relay television signals. They are also used by pipelines, by railroads, and by many other industries. A micro-wave relay system is actually a radio link which can be used to accomplish the same results as several, several dozen, or even several hundred telephone wires. In this system the radio energy is beamed from one relay station to the next, where it is power-boostered and beamed on to the next. This is repeated every 50 or so miles along the entire length of the system. The type of communication which is passed along depends largely on the use of the relay system. For example, such a system can be used to pass along messages from a central location to points hundreds, or thousands, of miles away. At the same time, the system could be used for controlling devices at remote locations. For example, in a pipeline installation a single dispatcher can control valves at desired points along the pipeline, although it might stretch for thousands of miles.

## **Government Services**

Many motion pictures have made us aware of the use of radio communication by the Army, Navy, Marine Corps, Coast Guard, and Air Force. In modern warfare this type of instantaneous communication is an absolute necessity. There are, however, many other types of government radio installations. Included among these are Meteorological aids, Forestry Service, and Bureau of Standards.

## Facsimile

Facsimile is a form of communication which has not, as yet, developed to a great degree. It is a system whereby newspapers, photographs, or other printed material are transmitted by radio. The facsimile receiver has a device called a printer, which reproduces the transmitted copy—newspaper pages, photographs, etc.—on a roll of paper.

## Radar

Radar is a specialized form of radio transmission which was developed during World War II. Its chief wartime use was in detecting and accurately determining the range of enemy aircraft. It has, however, found widespread use in the commercial field since wartime secrecy regulations were lifted. Radar installations aboard commercial airliners continuously plot a "map" of the terrain over which a plane is flying, and can also be used to determine the extent of storms toward which the plane is flying. All leading airports are equipped with radar landing equipment. Practically all ocean-going passenger vessels employ it as a navigational aid. A great majority of the boats on the Great Lakes and large rivers in the United States use radar, so that they can continue their operations in spite of rain or fog. Figure 3 shows a radar installation aboard the Dutch Lines palatial passenger ship NIEUW AMSTERDAM, and Figure 4 shows a technician adjusting radar equipment before it is to be installed on shipboard. Another widely known use of radar is as a speed checking device. Signs indicating "WARNING—SPEED CHECKED BY RADAR" are becoming almost as common along the nation's highways as the old familiar one "WARNING—DANGEROUS CURVE."

## Television Broadcasting

Television, as you know, is the transmission and reproduction of a view or scene by means of radio waves. The sound which is associated with the scene is also transmitted. Television transmission may be a black-and-white picture or a full-color picture.

One of the newest uses for television, and the use which may well prove to be the most important in the future, is **educational television**. The best qualified teachers can present their subjects from the television studio. These programs are broadcast to **many** schools in the particular area. In the schools the programs are picked up on special receivers or monitors where they are observed by the students in groups of perhaps several hundred. Receiving teachers work with these students to answer their questions, give examinations, etc. A series of experiments conducted by the Ford Foundation over a period of several years have indicated that the average



student receiving his instructions via TV does better than the student receiving instructions in the customary classroom manner.

Figure 5 illustrates one of the programs of the Kentuckiana Educational-TV Council originating from the UEL studios. Figure 5(A) shows a view of one end of the UEL studio while a high-school science class was being televised, and Figure 5(B) shows a closeup of this Educational-TV "Classroom." The subject being discussed when the picture was taken was minerals, and the various types of mineral and rock formations may be noted on the demonstration desks in front of the teacher and his guest.

## **Industrial Television**

Industrial television is one of the most rapidly developing branches of this fantastically expanding field. Industrial television is the use of TV cameras and receivers for purposes other than television broadcasting. For example, industrial television enables the operator of a steel mill to see at close range the progress of the red-hot steel as it moves through the mill, while he is seated at a distance in an air-conditioned control booth. It permits the highway department to observe the flow of traffic throughout the entire length of the tunnels on the Pennsylvania Turnpike. It makes possible for the scientist in an atomic energy laboratory to watch, from a safe distance, the action of deadly radioactive materials. Figures 6(A) and (B) illustrate an interesting application of closed-circuit television. In Figure 6(A) the scientists prepare an experiment to test the effect of atomic radiation on lubricating oil. The purpose is to develop better oils and fuels for atom-powered ships and planes of the future. When the experiment is conducted, the "target room" is empty, and the experiment is watched over closed-circuit television from a concrete-and-lead-shielded room, as may be observed in Figure 6(B).

Through the application of industrial television, a department store may exhibit special items at many points throughout the store, using monitors. Industrial TV can be used to check the operation of conveyors in industrial plants, to observe the movement of freight cars in railway switchyards, and to permit one operator to see any number of points in a plant simultaneously. New uses for industrial television are being found daily. We have listed only a fraction of its uses here.

## **Industrial Electronics**

Industrial electronics is a very general term which is applied to equipment using vacuum tubes or transistors, but which **does not** transmit radio waves through space. Electronics can be used to do many different things, such as sort fruit, check the purity of drinking water, regulate the heat of ovens in industrial plants and steel mill smelting furnaces, cook

hamburgers, compute at speeds thousands of times faster than humans (See Figure 7), operate juke boxes, check the color of dyes in cloth manufacturing plants, count the number of cars passing a point on the highway, and control chemical and mechanical processes. The list is almost endless, so wide is the use of electronics in our modern life. Electronics is found in the home, in industry, in government (electronic "brains" and electronic filing systems), and in defense.

Electronics is now a vital part of the nation's missile program. The extent of the use of electronics in the missile field is not fully appreciated by most people. Perhaps the most simple way to get a glimpse of the enormity of this phase of electronics is to recognize the fact that **more than one-half** of the billions of dollars spent annually in the missile field go directly into **electronics equipment, electronics personnel payrolls, and electronics research and development.** The opportunities for electronics technicians in the missile field are almost unlimited.

An application of electronics to the missile field is shown in Figure 8. In Figure 8(A) an engineer and a technician are discussing the space available for a particular piece of electronics equipment in a missile. In Figure 8(B) the engineer and technician are going over the circuit diagram of the electronics equipment, and in Figure 8(C) the technician is constructing the unit. In Figure 8(D) the complete unit is being tested. Figure 8(E) shows the computer used in the Firestone Engineering Laboratory for this type of work. In Figure 8(F) loads are being set up on the missile system for checking by the computer. In Figure 8(G) the operation of the electronics unit is being checked under various conditions of heat, cold, moisture, etc., and in Figure 8(H) the unit is being checked under vibrating conditions before it is installed in the missile. If the unit operates satisfactorily in the missile, it will then be mass-produced for other missiles.

Another interesting application of electronics is shown in Figures 9(A) and 9(B). The units, manufactured and distributed by UEL, are the CAM-EYE camera—Figure 9(A); and the CAM-EYE control unit—Figure 9(B). The camera, which takes "sequence" pictures on 16mm movie film, is controlled by the electronic control unit. The control unit "tells" the camera when to start and stop taking pictures and the time interval between pictures. These CAM-EYE Photographic Security Systems find wide application in the security field protecting banks, loan companies and other financial institutions from robbery, and protecting department stores, drug stores, and grocery stores from shoplifting. In industry the units are used to protect warehouses, loading platforms, and other critical areas from pilferage, to check the operation of processes and conveyors, and in time-study work.

## Telemetering

Telemetering is used in industry and in the missile field, and it often is handled by radio or micro-wave systems. Thus, it is a little difficult to decide just where to place it in this list of radio and electronics services. For this reason, we have placed it under a separate heading.

## Sound Waves

Sound waves are set up by a **vibrating object**. For example, as a bow is passed across the strings of a violin, the **strings vibrate** and produce sound waves. As a musician blows into a saxophone, the **reed in the instrument vibrates**. As we speak, the air passing through our vocal cords causes **vibrations**. All of these **vibrations produce sound waves in the air**.

To see just how the sound travels from the vibrating object to the ear, we will consider the loudspeaker in a radio receiver. There is a large paper cone in an ordinary loudspeaker (See Figure 10), which vibrates back and forth when the radio is operating. This vibrating cone alternately pushes and pulls on nearby particles of air and sets the air particles into vibration.

As the cone of the loudspeaker pushes forward, it shoves the air particles in front of it. This sets up a region of higher air pressure than normal in front of the speaker cone. One of these high-pressure regions begins to travel away from the loudspeaker each time the speaker cone moves forward.

As the cone of the loudspeaker moves backward, it leaves more room in front of it than previously for the air particles. This creates a partial vacuum in front of the speaker. This partial vacuum, or lower-than-normal air pressure region, travels outward from the speaker in front of a new high-pressure region each time the speaker cone moves forward.

This process repeats itself each time the loudspeaker cone moves forward and backward, which happens many times a second. The resulting regions of higher and lower air pressure, traveling away from the source, are known as **sound waves**. (This is further illustrated in the sketch of Figure 11.)

It should be mentioned that when a **sound wave** reaches the ear the air particles have **not** traveled from the speaker cone to the ear. A sound wave is made up of vibrating air particles and might be compared to a wave moving across the surface of a lake. The wave travels across the lake **but the water particles do not**. They merely vibrate up and down. The water particles stay in practically the same position all of the time, and only the **vibrating up and down motion** travels across the lake. In a like manner, air particles in a sound wave do not move very far; they merely move back and forth in a certain area. Each particle transfers its back-and-forth motion to the next particle. This forms traveling regions of high and low pressure, which are sound waves. The sound waves travel at a speed of approximately 1,100 feet per second.

As sound waves strike the ear drums, they cause the ear drums to vibrate. The vibrations of the ear drums are conducted to nerves which transmit the sensation of sound to the brain.

In addition to its limited range, there is another disadvantage to the use of sound alone for broadcasting. If several persons are talking at the

same time, we have no way of listening to any one of them and "shutting out" all of the others. Nature has not equipped us with any means of selecting or "tuning in" the particular person we wish to hear. This suggests another great advantage of the use of radio waves for broadcasting. Although there are thousands of stations broadcasting at the same time, the person operating his radio receiver can tune in one desired station and, in so doing, shut out all of the others.

## The Radio Station

Now that we know a little about the nature of sound, it will be possible to proceed with a discussion of what happens at a radio station. The program usually originates in the **studio**, as shown in Figure 12, and in the sketch of Figure 13 which illustrates an entire radio broadcasting system. The performance is conducted before a microphone which receives the sound waves set up by vibrations of the vocal cords of the performers and the reeds or strings of musical instruments. The microphone operates on the same principle as the mouthpiece of a telephone. The sound waves cause a diaphragm (a thin metal or foil disc) in the microphone to vibrate, and the microphone generates electrical waves in the circuit to which it is connected. These electrical waves correspond to the sound waves striking the microphone and are called **audio signals**.

The audio signals actually are sound waves in an electrical form. These audio signals are very weak and must be strengthened, or **amplified**, before they can be used further. They are carried by cable from the microphone in the studio to the **control room**, where they are amplified by vacuum tube circuits called audio amplifiers. The action of audio amplifiers will be explained in detail later in the training program.

A technician, called the control operator, operates the control console in the control room of the broadcasting station. It is his job to regulate the volume of the audio signal so that it will always be between certain specified limits, as indicated by a meter on the control console. The operation of controlling the volume is called "riding the gain" by radio and television broadcast personnel.

If the program consists of a variety show or of music by an orchestra, where several microphones are used, the control operator blends the outputs from the various microphones to obtain the desired effect. He also controls the switching of programs from local studios to chain programs or recorded programs. Chain programs originate in studios located in New York, Chicago, Hollywood, etc., and are sent to the local stations all over the country through telephone lines. Recorded programs may be on electrical transcriptions which are similar to phonograph records, or on magnetic tape.

The amplified audio signal is next carried to the transmitter. The transmitter may be next to the control room and it may be located several miles outside the city. In the latter case, telephone lines are used to carry the audio signal from the control room to the transmitter. At the transmit-

ter the audio signal is further amplified and at this point may be amplified (strengthened) so much that it is a million or more times as strong as when it left the microphone! In spite of the strength of this audio signal, it cannot be applied to an antenna and transmitted through space. This is because the audio signal is not actually a radio wave. To be transmitted through space, the audio signal must be combined with a radio wave called the "carrier." The carrier transports the audio signal through space to radio receivers.

## Block Diagram

Figure 14 shows a simple block diagram of the radio system we have been discussing. The sound waves, microphone, and audio amplifiers which have been mentioned can be seen. Also, in Figure 14, a block will be noted which is labeled **Carrier Section**. It is the purpose of this portion of the transmitter to generate the radio wave which serves as the carrier. Technically, this radio wave is a **radio frequency wave**, and it is usually abbreviated RF wave, or RF signal. The carrier (RF signal) and the amplified audio signal are both applied to the **modulated amplifier**. This portion of the transmitter **combines** the audio signal and the RF signal. The result is that the RF signal carries the audio signal "piggy back." This is why the RF signal is called the "carrier." The carrier is assigned to a definite frequency or place on your radio dial by the Federal Communications Commission. For example, WLW is assigned to a frequency of 700 kilocycles, or 70 on the dial of your radio.

Another technician is on duty at the transmitter, and it is his job to see that the transmitter is operating properly. He also records the readings of the many meters of the transmitter at regular intervals. The transmitter technician is shown recording the readings of the transmitter meters in Figure 15. This is done for two reasons. In the first place, a record of the meter readings is required by the Federal Communications Commission. Second, a close check of the meters can indicate that certain troubles are developing. For example, it can indicate that a particular tube is about to "burn out." Then the defective part, tube, or whatever it may be, can be replaced during one of the regular "off the air" periods, rather than cause a shutdown during the time when the station is supposed to be on the air.

Now that the audio signal has been combined with the RF signal, the combined signal must be "broadcast" in all directions to the radio receivers in the homes of the listeners. To do this, the modulated carrier, which is the name applied to the output signal from the modulated amplifier, is carried by means of wires from the transmitter to the transmitting antenna. The transmitting antenna is usually a tall steel tower. When the modulated carrier flows into this antenna, it produces radio waves which spread out in all directions. (In certain applications, such as a radio beacon, the radio waves are focused by special types of antennas into narrow "beams.") The

radio waves travel through space at the speed of light, which is **186,000 miles per second**. The radio waves carry the audio signal through space.

In our short trip through a radio station we have seen how sound waves are changed into audio signals, how these audio signals are combined with the carrier, and how this combined signal is broadcast. Now let us see how a radio receiver handles the problem of changing the radio waves back into sound waves.

## **The Radio Receiver**

As the radio waves travel through space they hit radio receiver antennas. These antennas might be located outside, as they were for many years, or might be built into the cabinets of the radio receivers. As the radio waves hit an antenna, they cause a **weak Radio Frequency** signal to be set up in the antenna. This weak Radio Frequency signal set up in the antenna of the receiver is exactly the same as the modulated carrier signal at the transmitter, except it is much weaker. It is probably less than one-millionth as strong as the modulated carrier signal at the transmitting antenna. The receiving antenna conducts the weak RF signals to the RF amplifier of the receiver as shown in the block diagram of Figure 16.

The RF amplifier in the receiver does **two** things. First, it **tunes in the desired station and tunes out all of the undesired ones**. It should be remembered that there are thousands of stations broadcasting at the same time, and the radio waves from most of these transmitters are hitting the receiving antenna and setting up RF signals in it. An unintelligible jumble would result if all of these were amplified and were heard in the loudspeaker at once. The RF amplifier selects the one station to which it is tuned and rejects the others. (The tuning process is one of the most interesting things in electronics theory.) Second, it **amplifies** the weak signal from the antenna so that it will be strong enough to use. After the RF signal has been amplified, it is passed along to a demodulator stage, commonly called a detector, which reclaims the audio signal from the RF carrier which brought it that far.

The action of the demodulator stage in the receiver is just the opposite of that of the modulated amplifier in the transmitter. The demodulator, or detector, **separates the audio signal** from the RF signal. The RF signal is discarded, since its only purpose was to **carry** the audio signal. The audio signal is then conducted into an audio amplifier stage, which builds it up to a sufficient strength for operation of a loudspeaker. When the audio signal flows through the windings of the loudspeaker, it causes the paper cone-shaped diaphragm of the loudspeaker to vibrate in exact step with the vibration of the diaphragm of the microphone in the broadcasting studio. This vibrating cone produces sound waves in the air which travel to the ears of the listeners. Thus, a perfect reproduction of the music or voices in the broadcasting studio is heard by the listeners. In other words, the listener hears the same sound he would hear if he were present in the radio studio.

## Summary of the Radio System

To summarize briefly the foregoing actions: At the studio we have taken sound waves in air, changed them to audio signals, amplified them, combined them with a carrier, and broadcast radio waves having the characteristics of the original sound waves. In the receiver we have "picked up" this weak RF signal, amplified it, removed the audio signal, amplified this audio signal and passed it through a loudspeaker which again produces sound waves. Since radio waves travel at 186,000 miles per second, all of this happens in a split second. **If a listener is sitting near his radio, he will actually hear the program a fraction of a second before a listener in the rear of the broadcasting studio would, because sound waves in the studio will travel only 1,100 feet per second.**

## The Television System

Since the first crude television picture was shown in 1927, television has captured the fancy of the public in a manner undreamed of by any other technical achievement. However, television—which is a transmission of both pictures and sound without the aid of wires—took almost 20 years of intensive research to develop to the point where the quality of the transmission was good enough and the cost low enough to insure its popularity with the general public. Thus, it was not until 1946 that commercial television became a reality. Now almost every community large enough to appear on the map is able to receive pictures from two or more stations. Even the Army finds application for television, as shown in Figure 17.

Most television programs originate in specially constructed TV studios (See Figures 18 and 19). As TV consists of the transmission of both pictures and sound, there are two separate operations taking place at the same time. The problems of handling the sound portion of the program are quite similar to those of radio, except the microphone is usually suspended above the performers from a microphone boom, as may be seen in Figure 19. Television cameras are used to "pick up" the picture portion of the program. Cameras and cameramen can also be observed in Figure 19. A closeup of a television camera and cameraman is given in Figure 20, a television camera in operation in the TV Studio of United Electronics is illustrated in Figure 21, and Figure 22 shows a closeup view of a TV camera with the top open.

Now that we have had a picture of the TV studio and the equipment located in it, let us see how it is possible for the television system to "pick up" a scene in the television studio and reproduce this scene on the screens of thousands or even millions of TV receivers.

Probably the first thing which should be emphasized is the fact that there is **no film** in a TV studio camera. Instead, the TV camera contains a camera pickup tube, or picture tube, as it is often called. Located on the front of the camera is a lens turret, which normally mounts four lenses, as may be seen in Figures 20 and 21. By means of a handle on the back of the camera (See Figure 22), the cameraman can choose whichever lens he desires for

use at a particular time. Through the action of the lens the scene being televised is focused on a sensitive plate in the picture tube, as illustrated in Figure 23.

Stated very briefly, then, the TV camera changes this optical image into electrical signals somewhat similar to the audio signals produced by a microphone. These signals are sent to the transmitter, where they are combined with a carrier. The combined signal then goes to the transmitting antenna for broadcasting. TV receiver antennas pick up the weak TV signals. After much signal amplification, the scene is reproduced on the screen of the TV set, which, as Figure 24 illustrates, actually is the "front" part of the picture tube.

The manner in which the scene focused on the sensitive plate of the television camera pickup tube is changed into an electrical signal, and how this electrical signal is then changed back in a reproduction of the scene on the screen of the television receiver, is indeed an interesting process.

## How a Picture is Reproduced

When one watches the screen of a television receiver, he thinks he sees a "moving picture" being presented on the screen before his eyes. However, this actually is an optical illusion. All workable methods of TV consist of **breaking the picture up into many thousands of parts, transmitting each of these parts one after another, and then putting these parts together again properly at the receiver to obtain the complete picture.** The fact that the picture must be broken down into parts for transmission and the parts then put back together at the receiver accounts mainly for the fact that television transmission is complex as compared to radio broadcasting.

Perhaps it would be of interest to point out that almost all means of reproducing pictures employ processes of breaking the picture down into small areas of light and dark. If you have a magnifying glass, or can borrow one, look at the newspaper photograph under this glass. You will discover that it is made up of small **dots of ink**—in other words, the original picture is broken down into the small dots of light and dark to reproduce it on the newsprint. If you were to use the magnifying glass to examine a photograph in a magazine, you would discover that it, too, is made up of many small dots, but that the dots are smaller and closer together than in the case of the newspaper reproduction. As a result, you can see more of the fine details in the magazine picture than in the newspaper picture. Even an ordinary photograph, if you could examine it under a very powerful magnifying glass or a microscope, would be found to consist of many dots (in this case they are dots of a silver compound) which are very small and very close together. A good photograph will contain even a greater amount of fine detail than a magazine reproduction. From this it can be understood that it is possible to break up any picture into a large number of small areas



or dots of light and dark, and that the smaller these areas are and the closer they are together, the more detail will be shown in the picture.

As mentioned, television also breaks up the picture into a large number of small areas of light and dark. However, there is one major difference between the reproduction of a television scene and the reproduction of a printed picture. When a person looks at a picture in a newspaper he sees all of the picture at once, because all of the small areas of light and dark are there for him to look at as long as he desires. In television, the picture is not reproduced all at once. Instead, each successive area of light and dark is reproduced, one after another, at such a rapid rate that the eye is tricked into believing it is seeing the entire picture at once!

After the eye responds to a **change** in light intensity, it retains the impression for approximately one-tenth of a second. Thus, if all of the small areas of light and dark forming the television picture are assembled on the TV screen at a rapid enough rate (in less than one-tenth of a second), this characteristic of the eye tricks the observer into thinking he is seeing the entire picture before him. Another thing which adds to this effect is the nature of the screen of the picture tube itself. The fluorescent material used for the screen is such that any spot which is caused to glow will continue to glow for a fraction of a second afterward.

## The Television Picture

In the television system the image to be transmitted is first broken up into narrow strips or lines, and these lines are, in turn, broken up into dots of light and dark. Figure 25 illustrates the manner in which a picture may be broken up into lines and then reproduced. The picture at the left shows the original scene, and at the right it can be seen broken up into the individual strips or lines. If we were to reassemble all of the individual lines at the right, by moving them close together, they would form the original picture.

The process in which a scene is divided into individual lines, and these lines reassembled at the receiver to form a reproduction of the picture, is called **scanning**.

Scanning can be explained very easily by the following example. Assume that on a very dark night a man desires to read a large sign on a wall. The only means of illumination he has is a flashlight which produces a narrow beam of light. To read the sign he would, naturally, first direct the beam at the upper left corner of the sign, and then move across the top line of writing of the sign. He would then lower it slightly and again trace across the sign, this time tracing out the second line of the sign. He would continue until he has read the entire sign. The flashlight illuminates only a small spot, but if it is moved rapidly, a whole strip or line appears visible. If it were possible to thus scan the entire sign in less than a tenth of a second, the eye would be tricked into "seeing the whole sign at once."

In the television system the scene to be televised is focused on the pickup tube in the camera, and the reproduced scene appears on the screen of the picture tube in the receiver. The **scanning** is done **entirely through the use of electricity**. In the camera tube a pencil-point-thin beam of electricity moves from the left edge of the top line, or strip (See Figure 25), progressively to the right edge of this line. This beam of electricity corresponds to the flashlight beam in our example. As the beam scans across the picture, it "senses" whether it is hitting upon a white, black, or gray area. In the picture tube of the TV receiver, another pencil-point-thin beam of electricity traces a strip progressively across the top edge of the TV screen. It reproduces a white area on the **receiver screen** each time the beam in the **camera tube** is striking a white area. Similarly, a black area is reproduced on the TV receiver screen when the beam in the camera tube is striking a black area, and a gray area is reproduced when the beam in the camera is striking a gray area. This ability of the beam of electricity in the camera tube to "sense" whether it is hitting upon a white, black, or gray area makes it possible for each line of the picture to be broken up into the small areas of white, black, and gray, just as in a newspaper picture.

After the first line has been scanned, the scanning beam in the camera and the one in the receiver picture tube move rapidly back to the left edges of their screens and down slightly. They then scan another line slightly lower on the picture than the preceding line. This process is repeated, line by line, until the entire picture has been scanned. Thus the areas of light and dark forming each line of the screen appearing before the camera are reproduced on the screen of the receiver. The entire picture is reproduced on the receiver screen in such a brief period of time that the eye of the viewer is tricked into seeing the entire picture at once. This process is repeated over and over again, 30 times a second.

In the actual television system the scene to be reproduced is broken into many more lines than those shown in the demonstration scene of Figure 25. This makes it possible for the TV system to reproduce the fine details in the picture. Just as soon as the scene has been completely scanned, the scanning process starts over again. If the people in the scene have moved, they will appear at slightly different locations in the successive scenes, which follow each other at intervals of  $1/30$  second, and thus the illusion of motion is established.

The scanning process is actually the heart of television. It makes it possible for the television system to break down the picture into a series of dots of light and dark, just as the picture in the printing process is composed of dots of light and dark. As this is being done at the studio, the "picture signal" is formed. This "picture signal" is then combined with a carrier signal for transmission in a manner quite similar to the arrangement explained for radio broadcasting. The TV receiver reverses the process by taking the "picture" signal away from the carrier. It applies the "picture"

signal to the picture tube, where the scanning process in the receiver re-assembles the complete picture. This, in a nutshell, is the fascinating process of television.

## Looking Ahead

This assignment gives you an introduction to the electronics field, and a simple, over-all picture of the radio system and the television system. Of course, your picture of the electronics field is not complete. This Assignment merely gives you a "speaking knowledge" of the entire field. Each fundamental electronics unit will be discussed in detail later in the training program. To illustrate this, refer again to Figure 12. This photo shows an announcer speaking into a microphone. In this assignment you were told that the microphone is similar to the mouthpiece in a telephone and that it changes sound waves into electrical waves, called audio signals. This is true, but it is not the complete story of a microphone. Later you will be given a complete explanation of the various types of microphones. You will learn, then, that there are many different types of microphones, each using a slightly different principle, to do the same job—changing sound waves into audio signals. Similarly, you will look at audio signals more closely, so that you will learn all you need to know about them.

As you go along in the training program, you will see what we mean when we say the entire training advances in a step-by-step process. For example, in the next assignment you will learn to recognize the various electronics parts, and find out, in a basic manner, what each does. In the following assignments you will learn how to "read" electronics wiring diagrams, or circuit diagrams, as they are called, and how to draw them yourself.

A little further in the training you will be given the latest information on just what electricity is and its relationship to magnetism. You will then be shown how both of these very interesting natural forces are used in electronics. Each of these basic things you learn will add a step to the stairway you are building and climbing toward becoming a thoroughly qualified electronics technician. The remaining assignments will be just as interesting as the first, and, equally important, you will keep learning more and more from each one. Your knowledge will grow by leaps and bounds as you master the fundamental facts given in each assignment.

A thorough training in electronics is worth every bit of the time and effort you give to obtain it. You are qualifying yourself for a field that is "wide open" in opportunities—exceptional opportunities that are available only to those who "know what they are doing" in electronics. Each time you tackle a new idea **and master it**, you advance your skill and experience in this field.

Many thousands of hours of thought, preparation, and revision have gone into this training program, so that each subject will be presented as thoroughly as possible and as simply as possible. Because of our constant touch with

the industry, we are able to include in the training all of those things which you need to know to meet the industry's requirements and to become a thoroughly qualified technician. Similarly, any information which has lost its value to the over-all electronics field has been eliminated. In this manner, the training program will provide you with the information you need, without holding up your progress with unnecessary material.

In this training program **you** will supply the ambition, but you're working directly **with** an instructor. He is right behind you, ready to give you help whenever you need it. To learn new material it is, of course, necessary for **you** to do the studying and thinking, but your instructor is eager to help you. He'll be glad to explain anything in a different way whenever you desire. You, yourself, know whether or not you understand an explanation. Before going from one part of an assignment to the next, make sure that you do understand.

We know that you will do your very best to master each new idea yourself. However, we do not expect you to understand everything without some help. At some point in the training you may run across something that just doesn't seem to make sense to you. Be sure to remember that, when and if this happens, your instructor is eager and prepared to give you personal instruction and the special explanations you need. Just tell him exactly what point you do not understand. Use the Consultation Service Blank which has been supplied for this purpose. When your instructor returns your answer to you, he'll send another Consultation Service Blank for your future use. Do not hesitate to use the Consultation Service whenever you feel the necessity. This is a fundamental part of the over-all training program. We don't want you to have a single technical question left unanswered as you progress through the training.

After you have finished your work on this Assignment, send in your answers to the test questions for grading. Then start your work on Assignment No. 2 as soon as possible, without waiting for your graded answers for Assignment No. 1 to be returned to you. This will make it possible for you to advance through the training program without delays.

Again, congratulations on your forethought in deciding to enter the electronics field. Lots of luck—we're with you!

## ASSIGNMENT 1

### TEST QUESTIONS

Be sure to number your Answer Sheet ASSIGNMENT 1. Place your Name and Associate Number on every Answer Sheet. Send in your answers to this assignment as soon as you have finished with it. This will give you the greatest possible benefit from our personal grading service .

1. List at least two uses of Industrial Electronics. (Do not include radio, television, or radar.) *BUTTONS*
2. Which travels faster, a sound wave or a radio wave? *RADIO WAVE*
3. In the missile field, does electronics play (a) a minor part or (b) a very important part?
4. What is the purpose of a microphone? *pick up audio wave convert to electrical energy*
5. What does the term AUTOMATION mean? *the use of electronics to control industrial process*
6. In a television system, is the entire picture transmitted at one time, or is the picture "broken up" into parts and these parts transmitted?
7. What does the control operator in the control room of a radio broadcasting station do when he is "riding the gain"? *controlling the volume*
8. The RF signal in a radio transmitter is called the carrier. Why? *it carries the audio signal*
9. What is TELEMETERING? *measuring at a distance*
10. In our example, the man "scanning" the sign on the wall used the beam of light from a flashlight to do this scanning. What kind of beam is used in scanning the image in a television camera? *electronic*

## HOW THE CAMERA TUBE WORKS

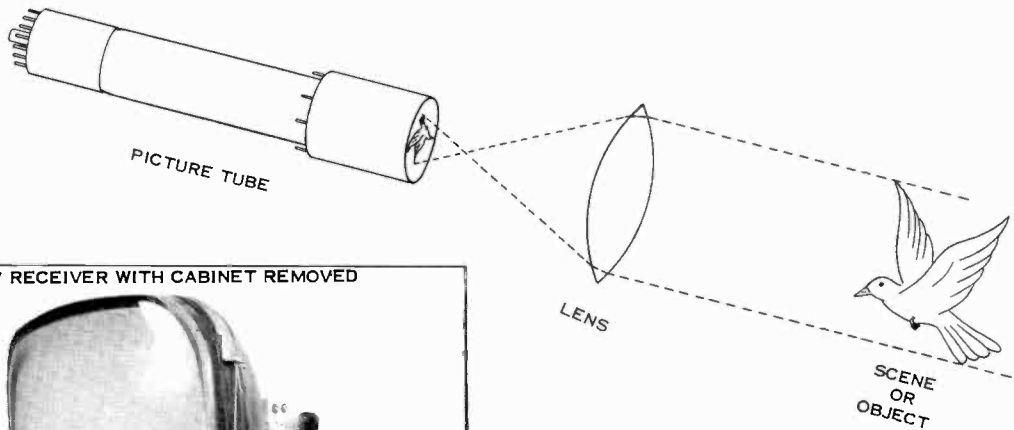

This sketch illustrates, simply, how the image is handled as it passes through the lens of a television camera.

FIGURE 23

TV RECEIVER WITH CABINET REMOVED

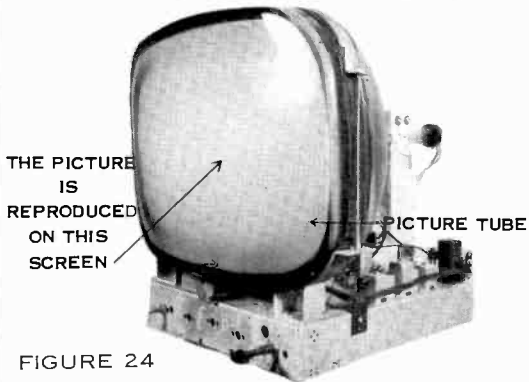

FIGURE 24

The picture tube in a TV set is very large, and the TV screen is formed by the "front" of the tube.

BREAKING UP A PICTURE INTO LINES



(COURTESY CBS-TV)

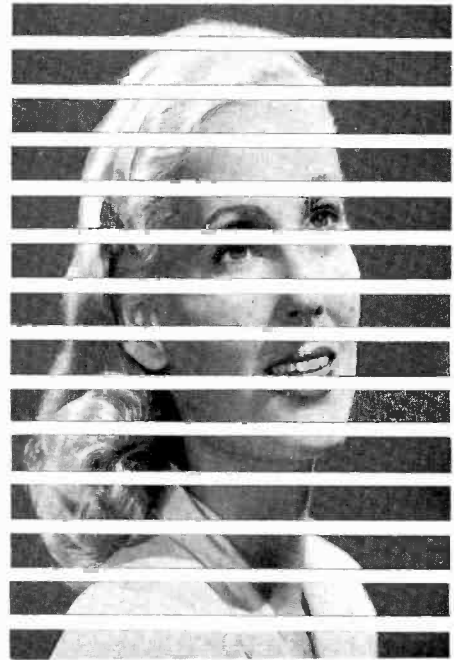

The figure at the right shows how the scene at the left (Sylvania's Roxanne) may be broken up into strips, or lines. In your mind's eye move the strips together, and you will be able to visualize how a TV picture may be broken into lines and then reassembled to form a complete picture.

FIGURE 25

## INSIDE VIEW

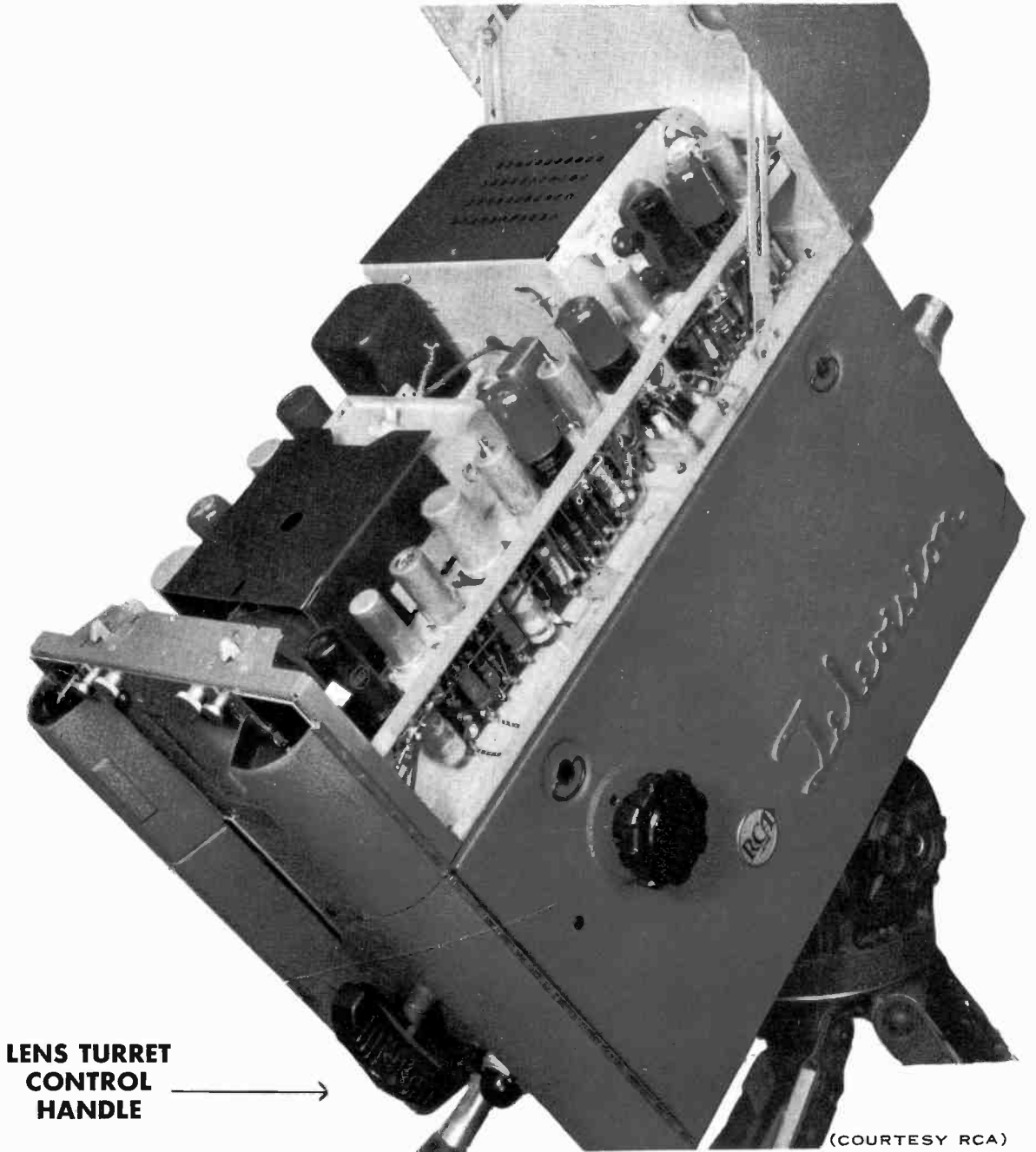

(COURTESY RCA)

When the top of a TV camera is opened, the tubes and other electronic parts are exposed, so that the technician can make adjustments or repairs.

FIGURE 22

## UEL ASSOCIATES IN ACTION



Here are shown four United Electronics Associates, operating one of the TV cameras and a boom microphone in one corner of the spacious, fully equipped, air-conditioned studios in the UEL training building. To the left of the Associates may be observed lighting equipment, studio monitor, scenic backdrop, etc., and behind the Associates are the soundproof windows of the control room.

FIGURE 21



## A TV CAMERAMAN IN ACTION



(COURTESY CANADIAN BROADCASTING CORP.)

This close-up shot shows a cameraman in action. The four lenses on the front of the camera are mounted on a "turret," and the turret may be rotated by means of a handle projecting from the rear of the camera (See Figure 22), to place the desired lens in front of the camera pickup tube.

FIGURE 20

## TV STUDIO SCENE

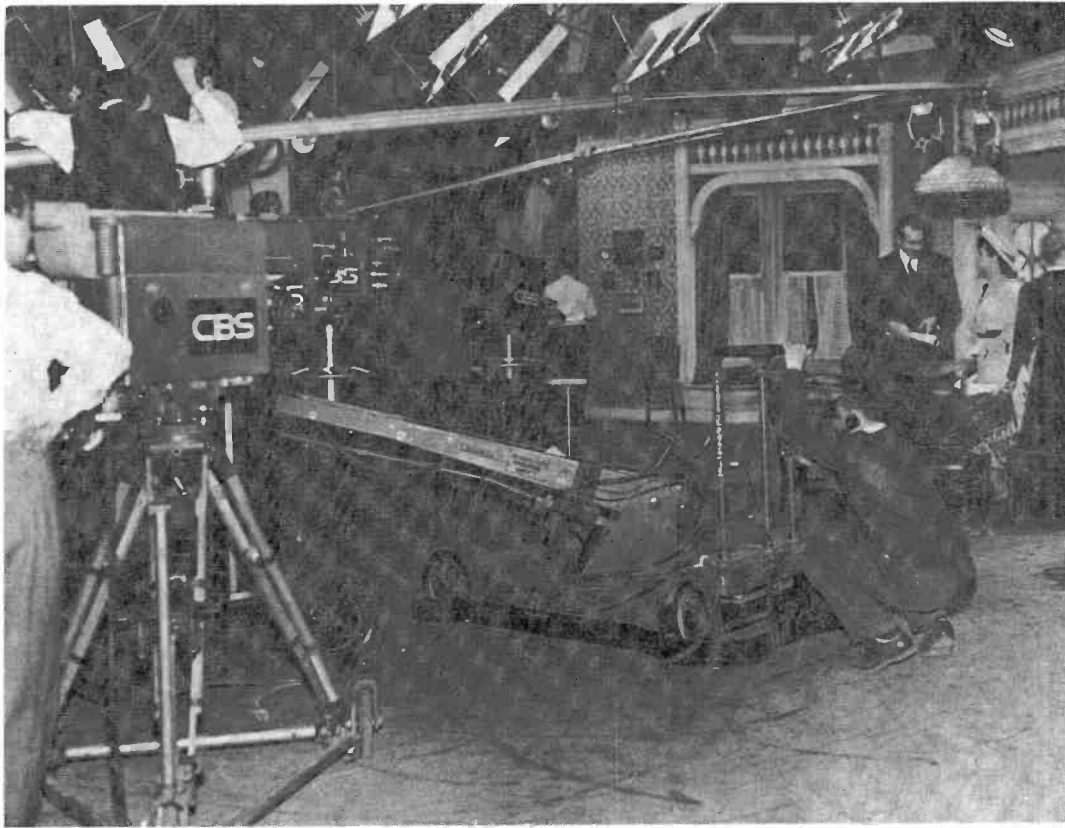

(COURTESY CBS-TV)

This on-the-air shot shows a program being televised. Note the lighting equipment, the "boom" microphones suspended above the heads of the performers, and the TV cameras and cameramen. (Two cameras are partly hidden from view, behind the first camera.) An assistant cameraman and other production personnel may also be seen.

FIGURE 19

## TV STATION



(COURTESY KROD-TV, EL PASO, TEXAS)

This beautiful new building houses the studios of KROD-TV in El Paso, Texas.

FIGURE 18

## ARMY TV EQUIPMENT



(COURTESY U. S. ARMY SIGNAL CORPS)

This Signal Corps remote TV system is one of the most complete TV stations ever mounted on wheels.

FIGURE 17

## AUTOMATION



(COURTESY MANNING, MAXWELL & MOORE, INC., AND THE OIL AND GAS JOURNAL)

This giant control panel houses the instruments which, together with other equipment, control the operation of the chemical plant of Petroleum Chemicals, Inc., at Lake Charles, Louisiana.

## AIRCRAFT RADIO

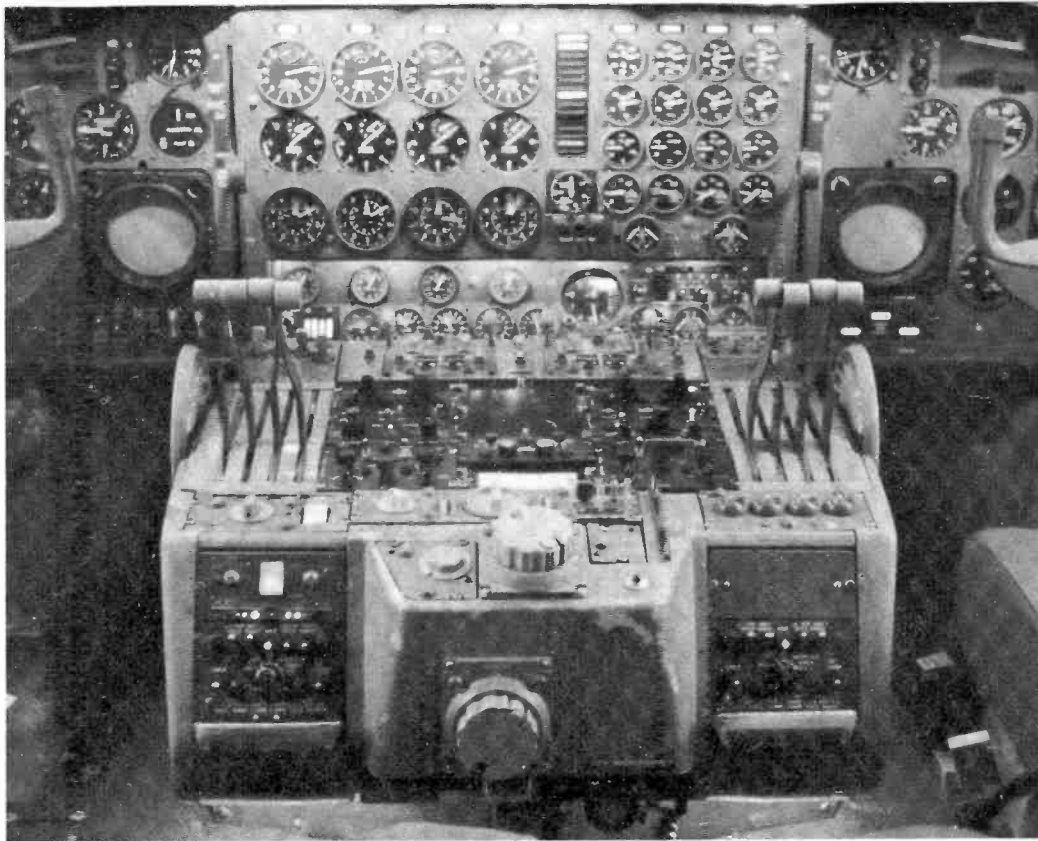

(COURTESY AMERICAN AIRLINES)

This is just a portion of the radio and electronics equipment carried by modern airliners.

FIGURE 2

## NAVIGATIONAL RADAR



(COURTESY SPERRY GYROSCOPE CO.)

This piece of Radar equipment, aboard the Dutch Lines' NIEUW AMSTERDAM, is typical of the Radar installation on ocean-going vessels.

FIGURE 3

## ELECTRONICS TECHNICIAN AT WORK

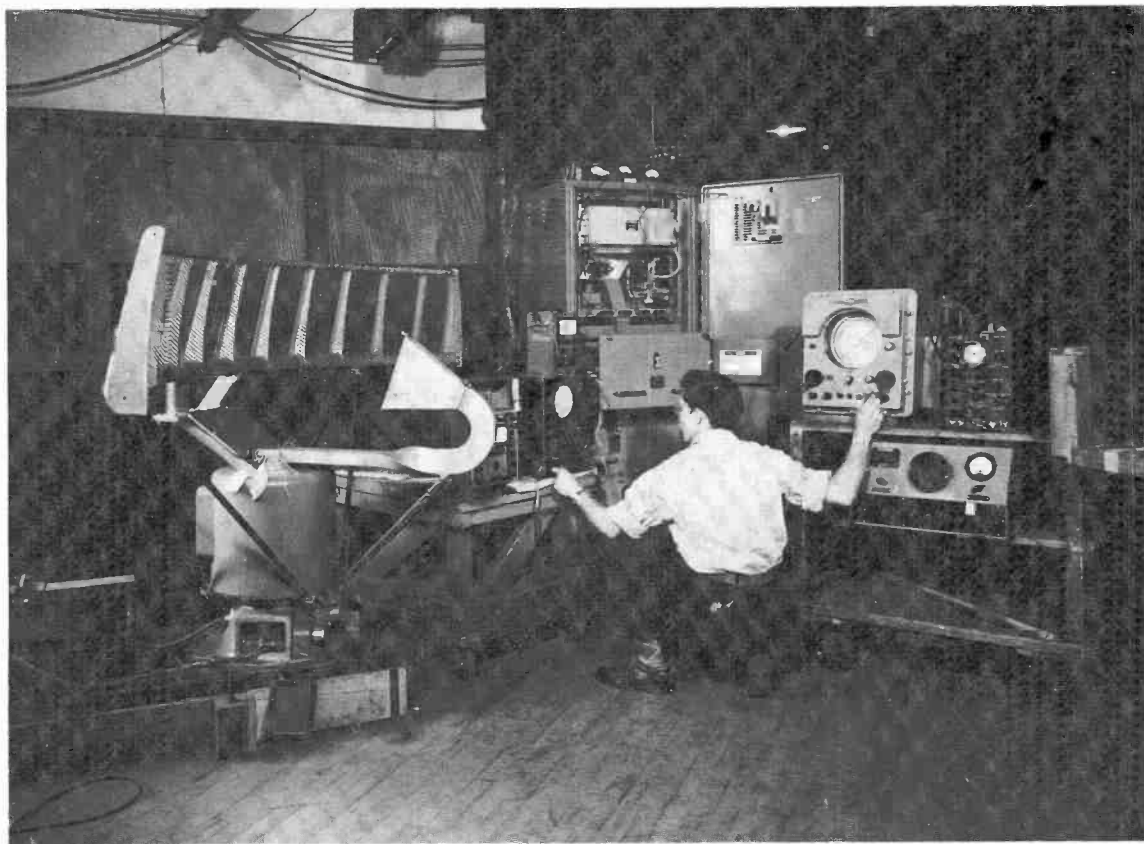

(COURTESY RAYTHEON MFG. CO.)

This Radar system is being "put through its paces" by a technician prior to its installation on shipboard.

FIGURE 4



## EDUCATIONAL TV



(A)

View of one end of UEL Studio with Educational-TV Program in progress



(B)

Closeup view showing Educational-TV Program being presented from UEL Studio

## INDUSTRIAL TV IN ACTION

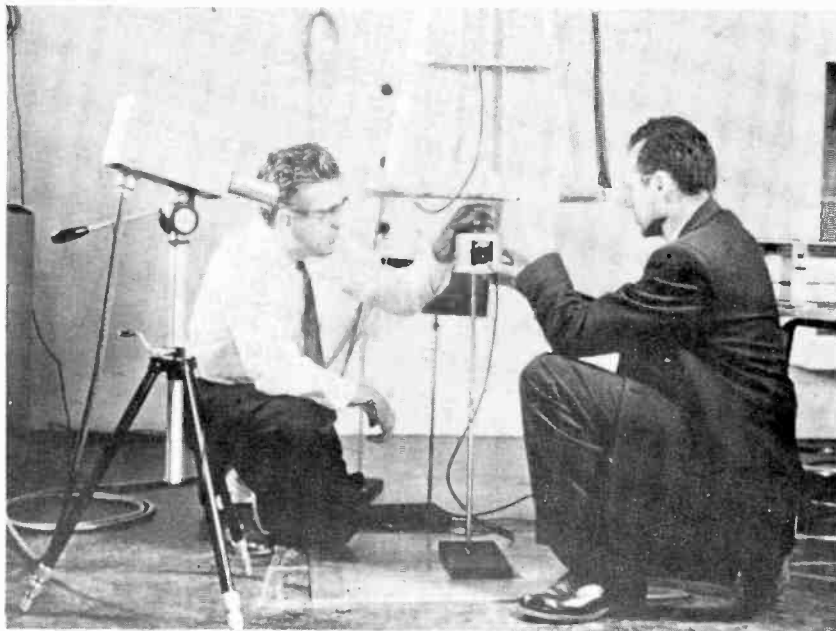

(A)

Closed-circuit TV camera set up to observe the effects of atomic radiation on lubricating oil.

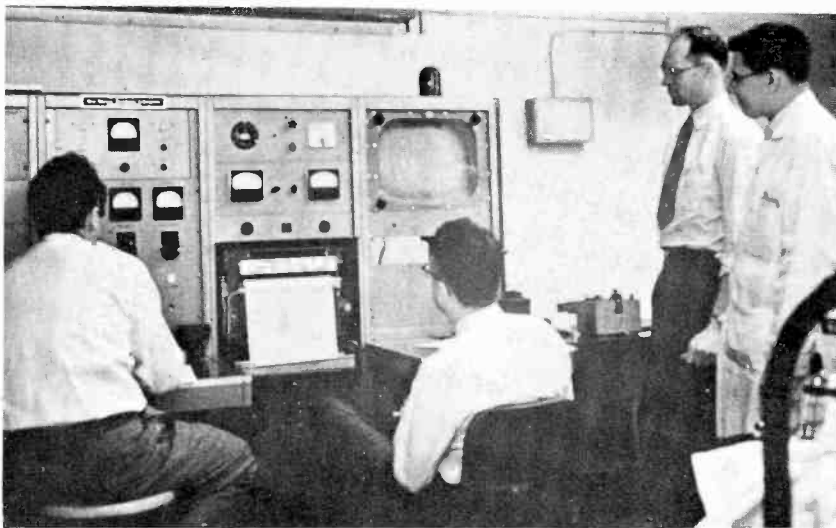

(B)

(COURTESY SHELL OIL CO.)

The experiment is watched on the closed circuit TV monitors in this shielded room in the Shell Development Company's Emeryville Research Center in California.

## WORKING ON AN ELECTRONIC BRAIN

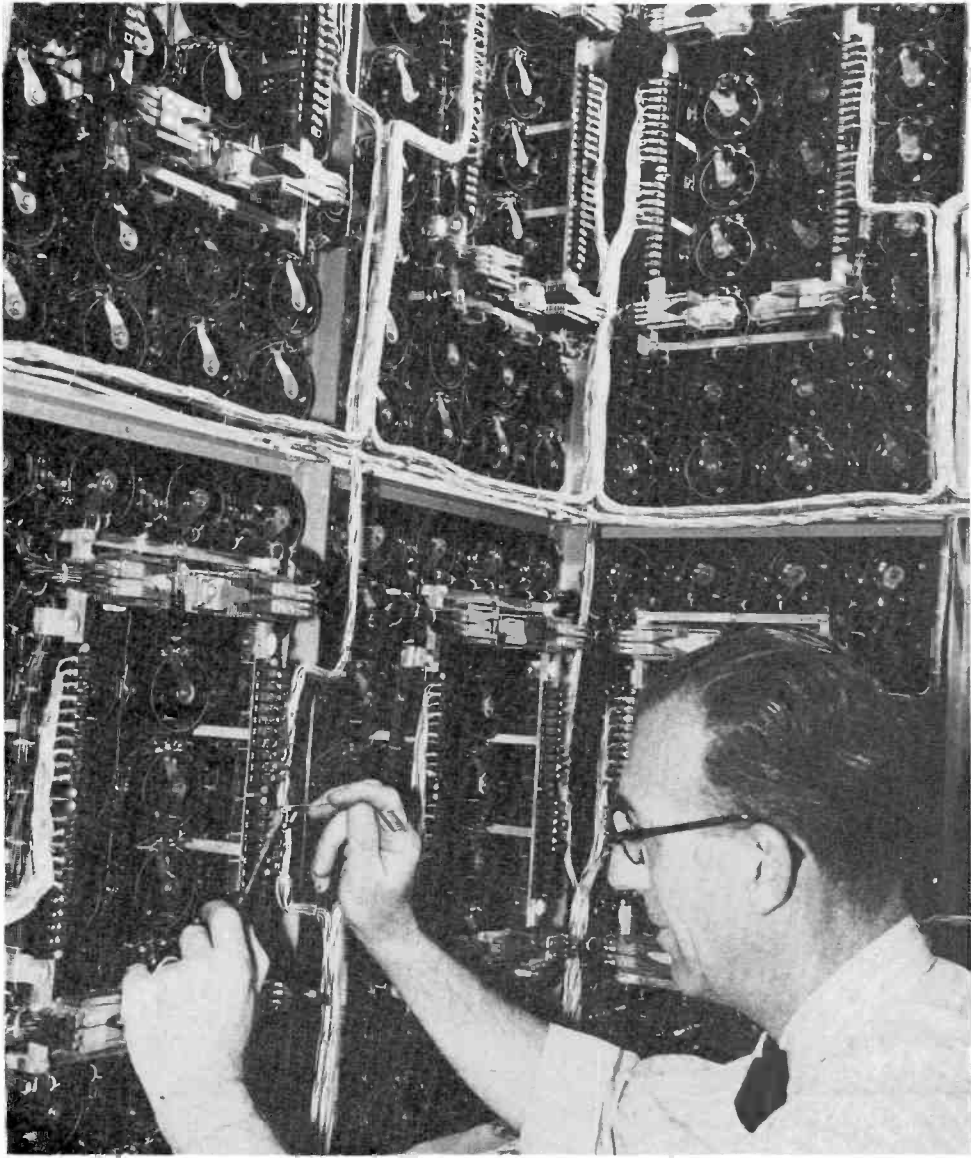

COURTESY GENERAL ELECTRIC CO.)

This technician is making a wiring change on an electronic brain. This particular "brain" was designed by GE for the American Gas and Electric System, and simulates, mathematically, one of the nation's largest electric power networks. Its use is expected to save AGE about \$100,000 yearly.

FIGURE 7

ENGINEER AND TECHNICIAN IN

MISSILE FIELD

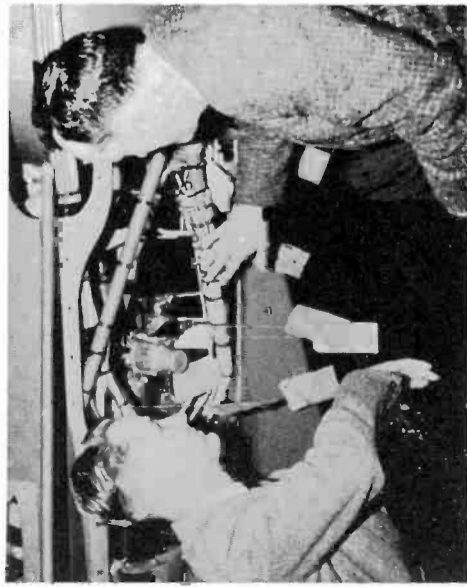

(A)

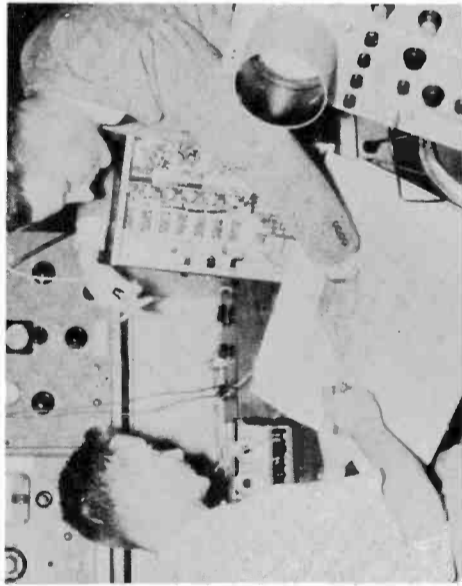

(B)

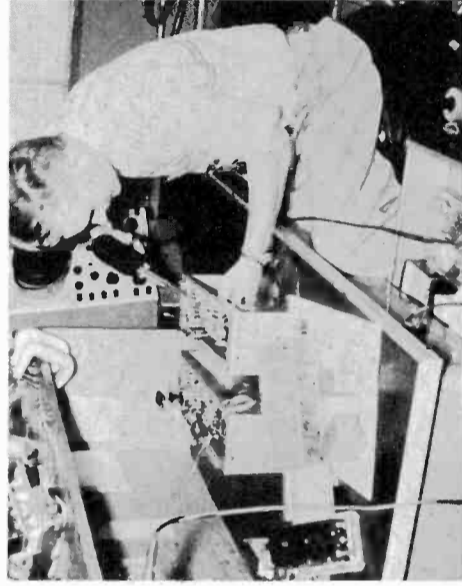

(C)

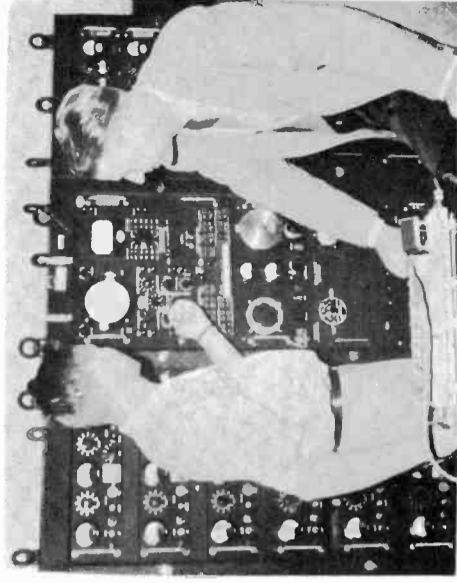

(D)

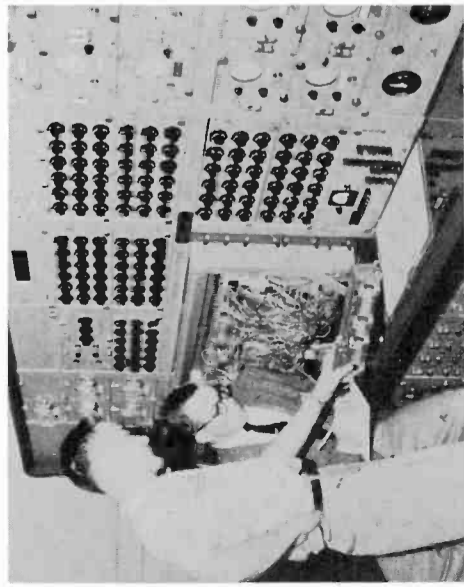

(E)

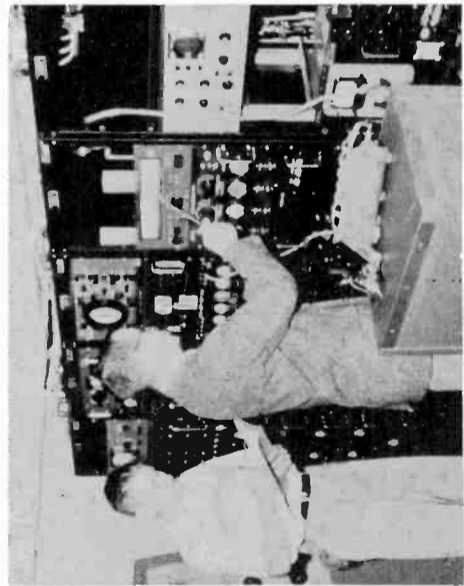

(F)

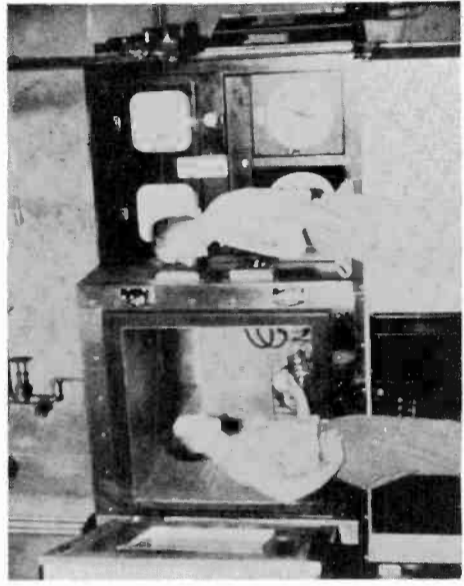

(G)

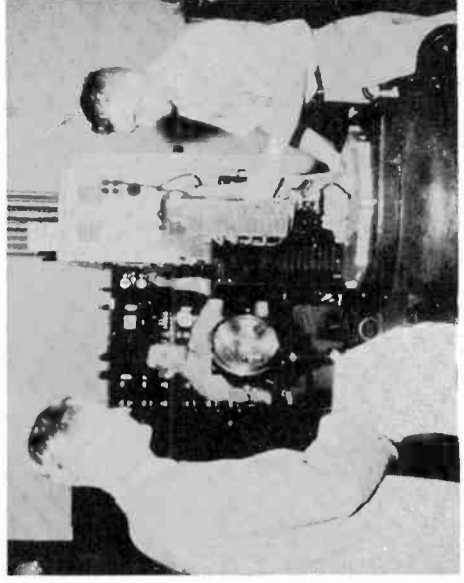

(H)

FIGURE 8

(COURTESY FIRESTONE TIRE AND RUBBER CO.)

## CAM-EYE PHOTOGRAPHIC SYSTEM



(A)

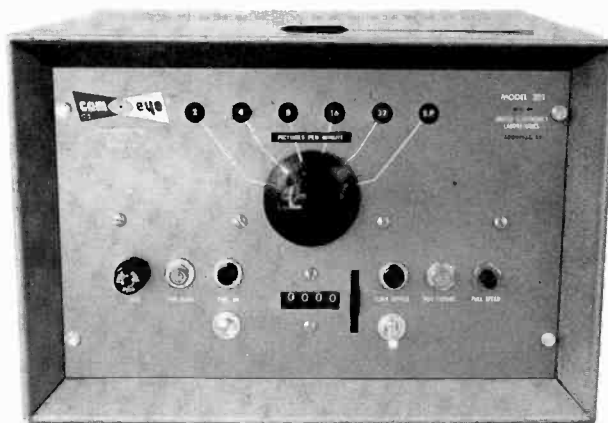

(B)

This equipment provides a photographic record of events. The camera is controlled by the electronic control unit.

# WHERE THE SOUND COMES FROM

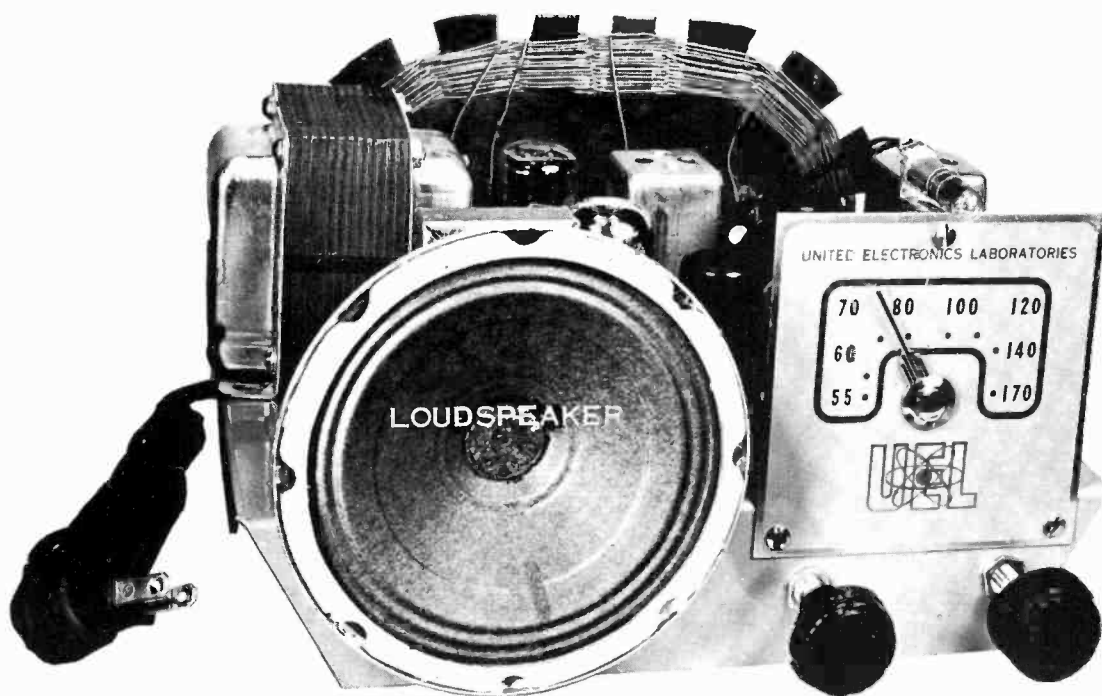

The vibrating cone of the loudspeaker sets up sound waves in the air.

FIGURE 10

## HOW SOUND TRAVELS



The sound waves travel outward from the speaker and strike the eardrums of listeners to produce the sensation of sound.

FIGURE 11

## THE MIKE IN THE RADIO STATION



(COURTESY THE CHRISTOPHERS)

As the newscaster speaks, the sound waves set up by his vocal cords travel to the microphone which converts them into audio signals.

FIGURE 12

## THE RADIO BROADCASTING SYSTEM

FIGURE 13

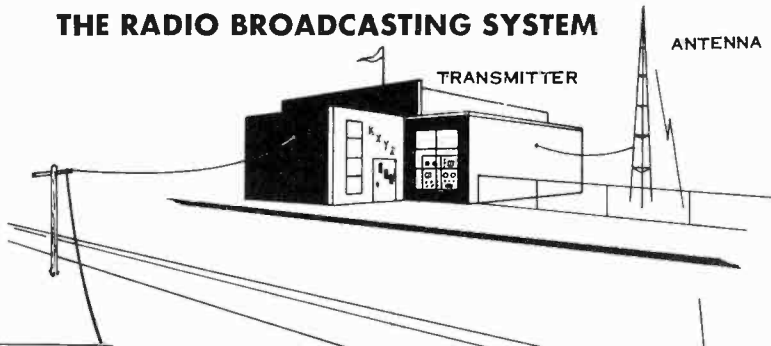

STUDIO

CONTROL ROOM

RECEIVER

This sketch illustrates the complete radio broadcasting system from the studio to the receiver.



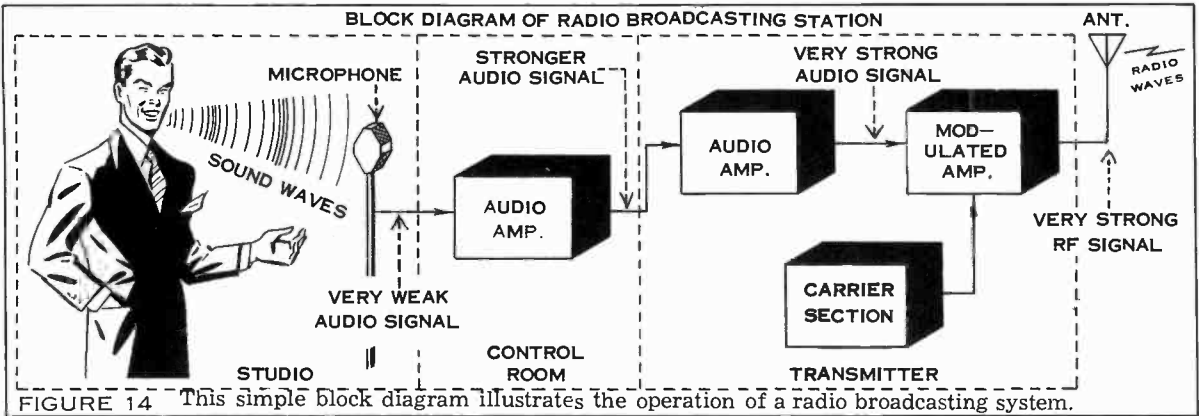

**LOGGING THE DIALS**



(COURTESY WAAM, BALTIMORE, MARYLAND)

Periodic reading of the equipment meters, logging the readings, and making constant comparisons keep the station's equipment functioning full-time at maximum efficiency.

**FIGURE 15**

