

FREQUENCY DISCRIMINATOR AND AUDIO AMPLIFIER

**LESSON
73 RA**



RADIO-TELEVISION TRAINING SCHOOL, INC.

5100 SOUTH VERMONT AVENUE • LOS ANGELES 37, CALIFORNIA, U. S. A.

THE DISCRIMINATOR AND AUDIO AMPLIFIER

It is, as you know, a known fact that the output of the limiter stage in the f-m receiver provides a frequency-modulated signal of unvarying amplitude for all normal reception conditions. The average frequency or center frequency of this signal is the intermediate frequency; eight to ten or more megacycles. In this signal are represented the audio frequencies of the sound to be transmitted, also the loudness or volume of sound. The audio frequencies, in cycles per second, are represented by how many times per second the signal frequency deviates from the center frequency. The loudness or volume is represented by how far the signal frequency deviates.

The frequency-modulated signal goes to the input of the discriminator stage. The job of the discriminator is to change the deviations of intermediate frequency into variations of potential at audio frequencies, so that the varying potentials may be put through the audio amplifier to control corresponding currents which actuate the loud speaker.

In order that sounds may be heard, the cone or diaphragm of the loud speaker must vibrate at an audio-frequency rate. The vibration is due to power brought into the speaker by current flow. The current results from potentials. These potentials must vary at audio-frequency rates. If they vary at higher frequencies the speaker cone or diaphragm may vibrate, but the vibrations will not be audible. At frequencies so high as intermediate frequencies the cone or diaphragm will not even vibrate, because its mass and inertia, weight and sluggishness, are too great.

At the input to the audio amplifying system which precedes the loud speaker we must have potentials at audio frequencies, not at frequencies so high that audible sounds cannot be produced. The input to the audio amplifying system is taken from the output of the detector in amplitude-modulation receivers, and from the output of the discriminator in frequency-modulation receivers. At the output of the discriminator we want potentials which increase in one direction, say positive, when the input frequency increases, and which increase in the opposite direction, or negative, when the input frequency decreases.

If we succeed in obtaining output potentials which follow the input frequencies we shall have solved the whole problem of detection or demodulation of the f-m signal. Then changes of output potential will reproduce the correct loudness of sound, because the farther the input frequency deviates the greater will be the output potential, and that means louder sounds from the speaker. The changes of output potential will reproduce the correct audio frequencies, because these changes of potential will occur at the same rate as the changes of input frequency, and that is the audio-frequency rate of the original modulation, in cycles per second.

THE PROBLEM OF DETECTION

Let's see what will happen if we apply to a detector such as used in amplitude-modulation receivers the frequency-modulated constant-amplitude signal from the limiter of the f-m receiver. Fig. 1 shows such a detector, with the following audio amplifying system.

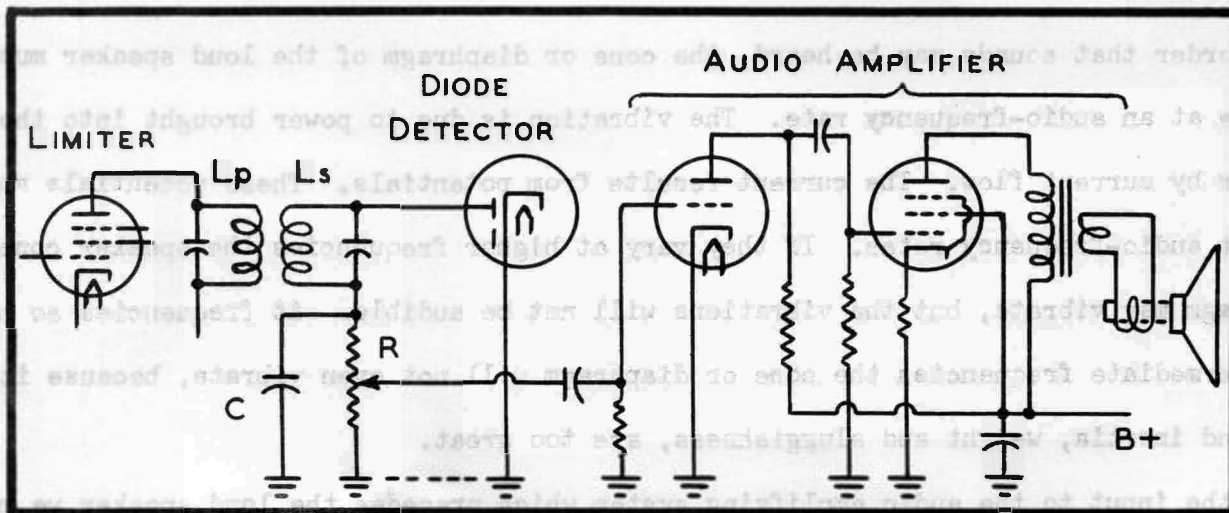

FIG. 1. A constant-amplitude signal applied to an ordinary diode detector would not produce audio frequencies at the detector output.

When there are variations of current in the primary L_p of the transformer, corresponding variations of potential will be induced in the secondary L_s . This secondary winding is in a circuit which includes the diode detector, the resistor R , and capacitor C , with the circuit completed through ground. Due to rectification in the diode there will be pulses of current in this circuit only during the alternations of potential which make the diode plate positive with reference to its cathode. These pulses

will be at the same rate as the frequency coming to the transformer which is the intermediate frequency with the deviations of frequency.

The frequency of current pulses in the detector circuit will have the average value of the intermediate frequency, with deviations of no more than 75 kilocycles either way. This means that the pulse frequency will be eight to ten or more megacycles; far above audibility. The high-frequency pulses charge capacitor C , which discharges through resistor R . Then in R we have an average current rate which corresponds to the average value of the alternating potential induced in the detector circuit. But this average potential always is the same, because potential is another name for amplitude, and we are using a signal of constant amplitude. The final result is that the output of the detector, and input to the audio amplifying system, have no variations at all - neither at audio frequencies nor at any other frequencies - and no sounds representing the signal will come from the loud speaker.

A DOUBLE-DIODE CIRCUIT

We may as well discard the usual amplitude-modulation detector and, for the next step, try using two diode rectifiers connected as shown in Fig. 2. Variations of

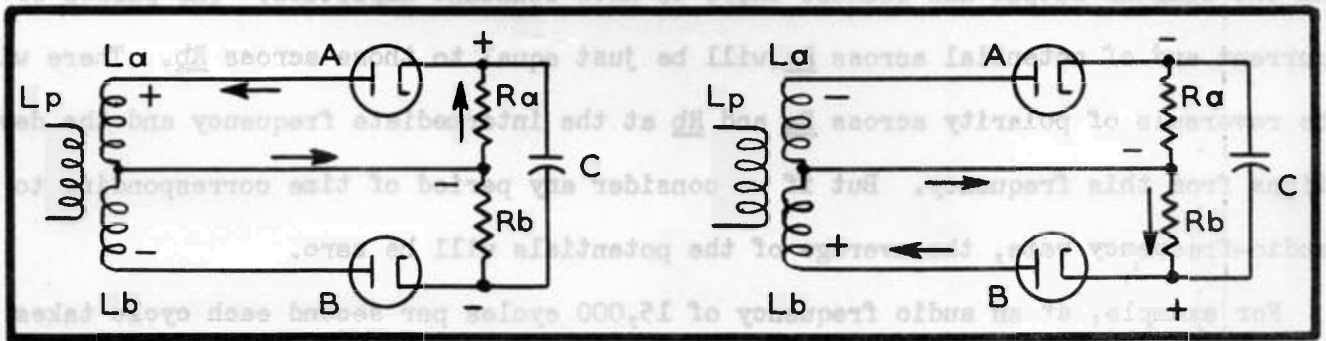

FIG. 2. Two diodes connected to produce opposite polarities in their load resistors. current in the primary L_p will induce alternating potentials in the secondary which consists of sections L_a and L_b . During increases of primary current the secondary potential will have a certain polarity, which may be assumed to make the top of L_a positive and the bottom of L_b negative, as in the left-hand diagram. During the decrease of primary current the induced secondary potential will reverse, as in the right-hand diagram.

In the left-hand diagram the plate of diode A is made positive with reference to its cathode, and there will be electron flow in this diode and in resistor Ra as shown by arrows. The top of Ra will become positive and the bottom negative. The plate of diode B now is negative with reference to its cathode, and there will be no electron flow in the circuit of this diode. Because there is no electron flow in resistor Rb, the top and bottom of this resistor are at the same potential.

In the right-hand diagram the plate of diode B is positive and that of diode A is negative. Now there is electron flow in diode B and resistor Rb, as shown by arrows. The electron flow is in such direction that the top of Rb is negative and the bottom positive. There is no electron flow in diode A, with its plate negative, nor in resistor Ra, and so the top and bottom of Ra are at the same potential.

Now we have, across resistors Ra and Rb, potentials which reverse their polarity at a frequency which is the same as that put into the transformer. Across the two resistors we may connect a capacitor C to be charged by the potential differences, and which may discharge through the two resistors. But the potentials applied to the two diodes are equal, because these potentials result from amplitudes of current changes in the limiter output and because there we have constant amplitude. The pulses of current and of potential across Ra will be just equal to those across Rb. There will be reversals of polarity across Ra and Rb at the intermediate frequency and the deviations from this frequency. But if we consider any period of time corresponding to an audio-frequency rate, the average of the potentials will be zero.

For example, at an audio frequency of 15,000 cycles per second each cycle takes $1/15,000$ second. If the intermediate frequency is 10 megacycles, each cycle will take $1/10,000,000$ second. Then, during any one audio-frequency cycle, there will be 667 of the intermediate-frequency cycles, and since their average amplitude is zero (just as with any alternating potential or current) the output will be zero so far as any audio frequency is concerned.

Fig. 3 shows what we should like to do in the double-diode circuit. When the incoming frequency deviates to a frequency higher than the center value, as at the left, we should like to have the potentials applied to diode A become greater than those

being applied to diode B. Then each pulse of current in the circuit of diode A would be greater than the pulse in diode B during the same cycle. There would be greater average currents in R_a than in R_b and greater potential differences across R_a than across R_b. During any audio-frequency period of time, while we have the higher deviation frequency, the top of capacitor C would get stronger positive potentials than negative potentials, and C would acquire a net charge and a net voltage, with the

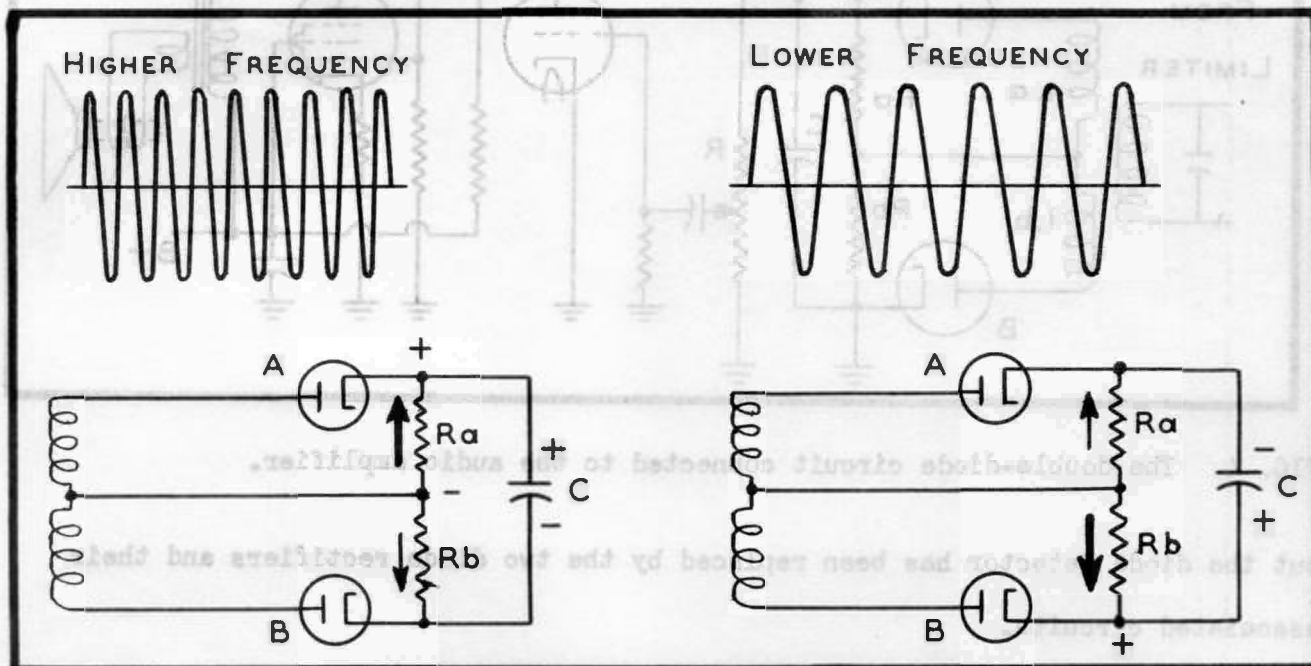

FIG. 3. At higher and lower frequencies there should be differences between average potentials in the two load resistors.

upper terminal positive and the lower one negative.

When the incoming frequency deviates to a value lower than the center frequency, as at the right, we should like to have the potentials applied to diode B become greater than those applied to diode A. Then current pulses and potential differences in B would be greater than in A, the capacitor C would charge in such polarity as to make the bottom terminal positive and the upper one negative. If all this could be done, we should have across capacitor C, and across the connected outer ends of resistors R_a and R_b, potentials which would rise, fall and reverse with deviations of incoming frequency. Since these deviations represent the audio-frequency modulation of the signal, this audio-frequency modulation would appear in the variations of potential across capacitor C, and resistors R_a and R_b.

Then, as shown by Fig. 4, we would need only to connect the output audio-frequency potential variations from capacitor C , or resistors R_a and R_b , to the input of the audio amplifying system. Here the audio system is just like the one shown in Fig. 1,

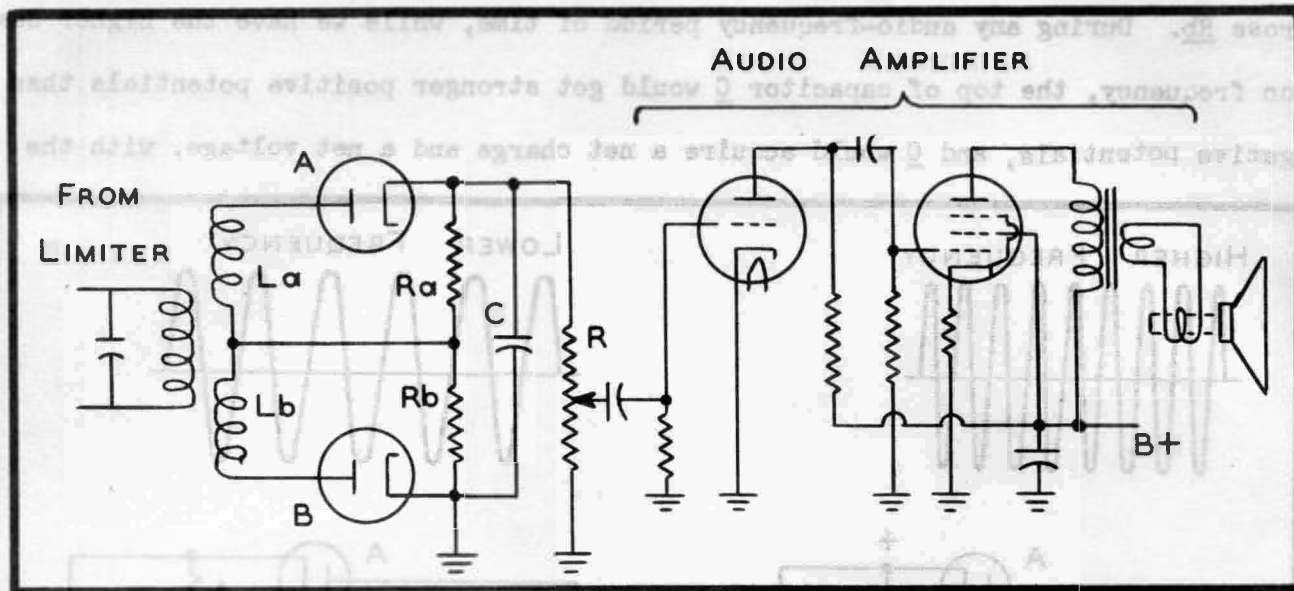

FIG. 4. The double-diode circuit connected to the audio amplifier.

but the diode detector has been replaced by the two diode rectifiers and their associated circuits.

MAKING THE DISCRIMINATOR WORK

When examining Fig. 2 it appeared that the two diode plates will become positive alternately during each cycle, and that there will be current in the two diode circuits at alternate times. This is shown in Fig. 5 where the alternating potential on the plate of diode A is shown by curve Ea, and the resulting rectified current in the circuit of diode A is shown by the pulses Ia. Similarly, the alternating potential and current for diode B are shown by curves Eb and Ib. The potentials Ea and Eb are in "opposite phase", or have opposite time relations. The word phase, as you know, is used when referring to the relative timing of potentials and currents in alternating-current circuits.

We learned from Fig. 3 that effective discriminator action will result if we can vary the potentials and resulting currents in the diode circuits in accordance with deviations of incoming frequency. Now we are going to vary the potentials and

currents in just that way.

Look at Fig. 6. At the top is represented our original potential on diode A, by means of the curve marked Ea. At the same time we are applying to this diode an

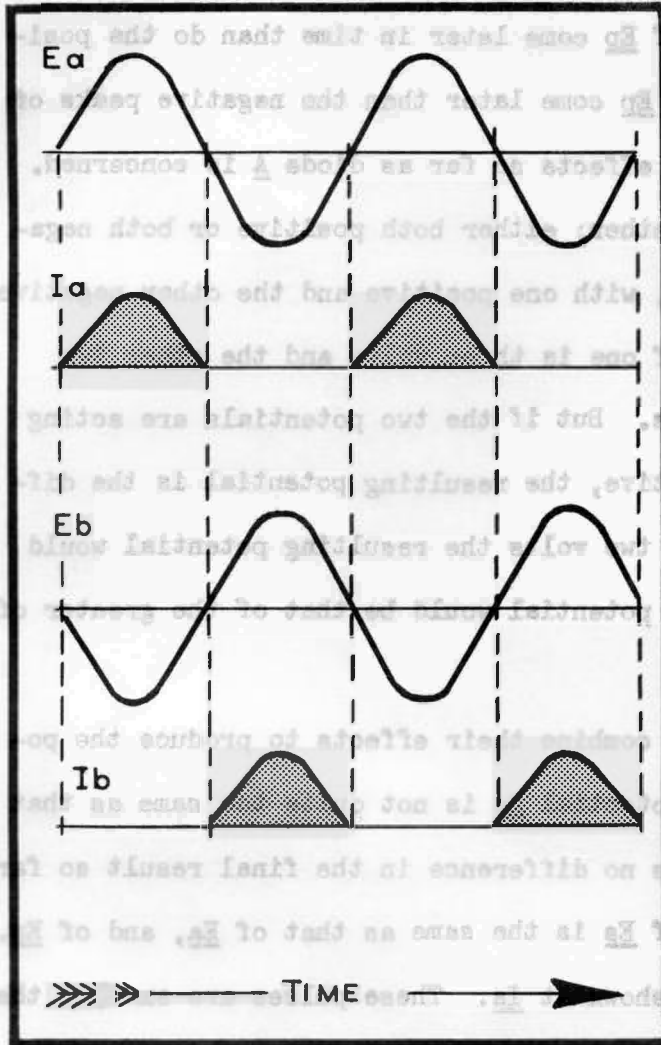

FIG. 5. Time relations of potentials and currents in the diode circuits.

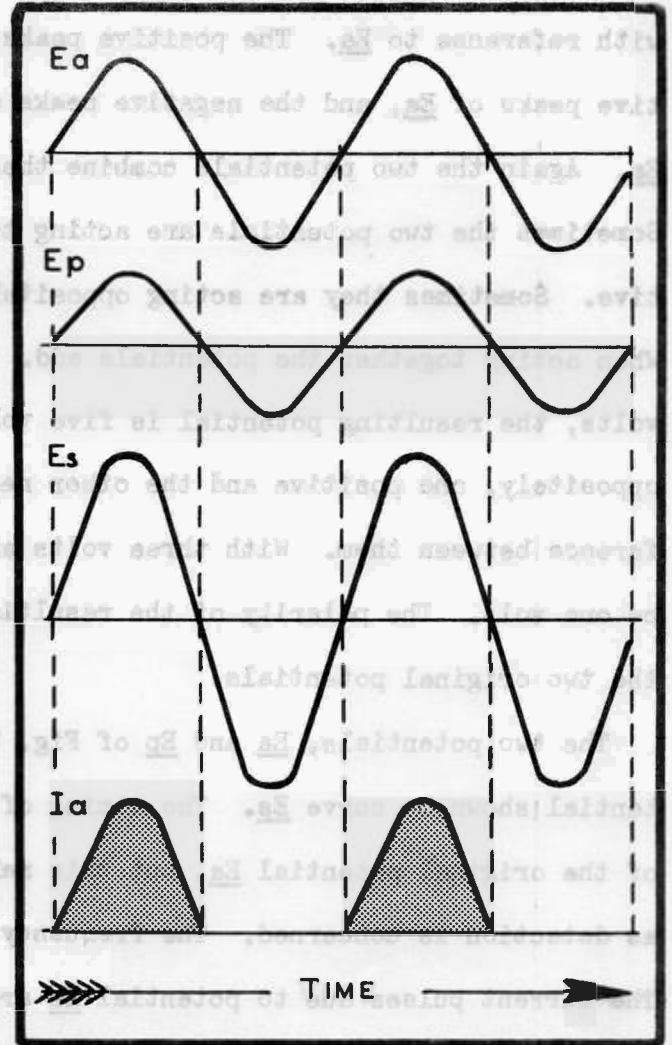

FIG. 6. The result of adding an extra "in phase" potential in one diode circuit.

additional potential shown by the curve Ep. The vertical broken lines represent simultaneous instants of time. Potential Ep has its maximum positive values, maximum negative values, and zero values, at exactly the same instants as the similar values of potential Ea. The two potentials Ea and Ep and "in phase", and they act together or add together. The result on diode A is a potential Es, which is the sum of the other two. This stronger potential applied to diode A causes a greater current in the

circuit of this diode. This current is represented by the pulses at Ia. Note that these pulses are higher, consequently greater, than the pulses shown at Ia in Fig. 5, where we have only the potential Ea acting alone.

Now look at Fig. 7. Here we have shifted the timing or the phase of potential Ep with reference to Ea. The positive peaks of Ep come later in time than do the positive peaks of Ea, and the negative peaks of Ep come later than the negative peaks of Ea. Again the two potentials combine their effects so far as diode A is concerned. Sometimes the two potentials are acting together; either both positive or both negative. Sometimes they are acting oppositely, with one positive and the other negative. When acting together the potentials add. If one is three volts and the other two volts, the resulting potential is five volts. But if the two potentials are acting oppositely, one positive and the other negative, the resulting potential is the difference between them. With three volts and two volts the resulting potential would be one volt. The polarity of the resulting potential would be that of the greater of the two original potentials.

The two potentials, Ea and Ep of Fig. 7, combine their effects to produce the potential shown by curve Es. The timing of potential Es is not quite the same as that of the original potential Ea, but this makes no difference in the final result so far as detection is concerned. The frequency of Es is the same as that of Ea, and of Ep. The current pulses due to potential Es are shown at Ia. These pulses are smaller than those of Fig. 6. Thus we learn that bringing in an additional potential which is in phase with the original potential will increase the current pulses (Fig. 6), and that shifting the phase or the timing of the additional potential will lessen the current pulses.

In Fig. 8, the timing of the additional potential Ep has been shifted even farther, so far, in fact, that Ep is at every instant acting exactly opposite to potential Ea. The two potentials now are in "opposite phase"; each has its maximum positive value or peak while the other has its maximum negative peak. Now the resulting potential, shown by curve Es, is very small. It is equal only to the

difference between potentials E_a and E_b . Naturally, the pulses of current, shown at I_a , are very small. It becomes plain that the current pulses in the diode circuit may be made large or small, or of any value in between, merely by shifting the timing or

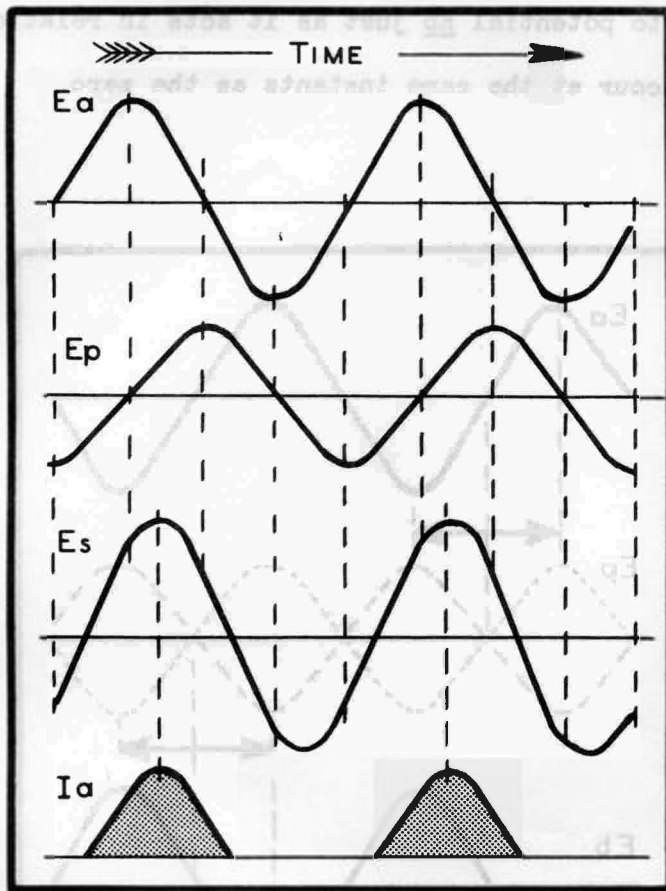

FIG. 7. Current pulses are weakened when the extra potential is "out of phase" with the original diode potential.

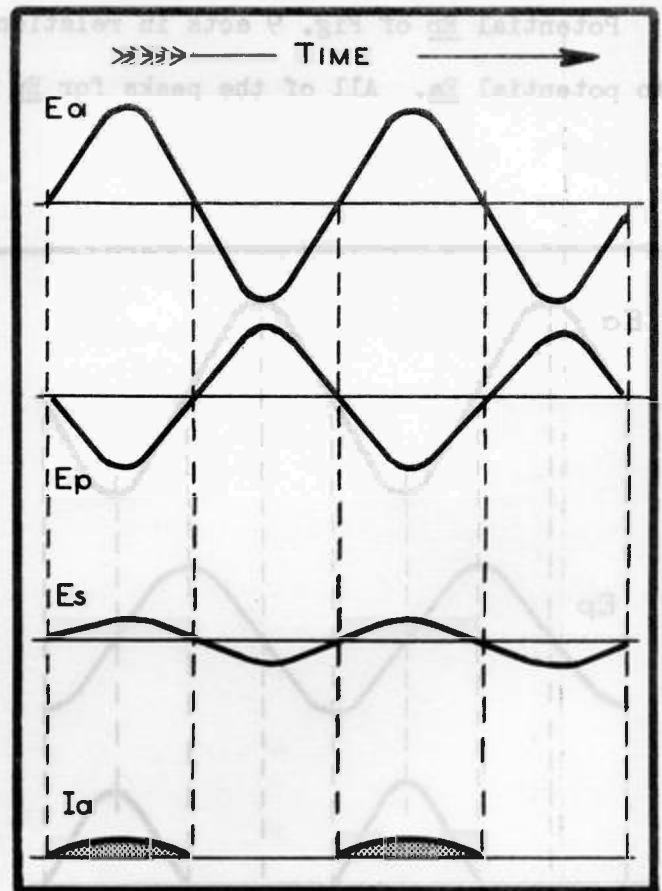

FIG. 8. When the extra potential is in "opposite phase" the current pulses are reduced nearly to zero.

the phase relations of two potentials acting in the same circuit.

Figs. 6, 7, and 8 show what happens in the circuit of diode A as the additional potential is shifted in phase while the original potential remains fixed in relation to time. We might draw a new set of curves to show what would happen in the circuit of diode B when introducing an additional potential and shifting its phase. The curves would be just like those of Figs. 6, 7, and 8.

Instead of using two separate additional potentials, one for diode A and another for diode B, we are going to use the same additional potential in the circuits of both diodes. In Fig. 9 we have at the top the curve for the original potential on diode A,

which is E_a . In the center is the additional potential, E_p . This much of the graph is just like the two upper curves of Fig. 7. Down below we have added the curve for the original potential in the circuit of diode B . Curves E_a and E_b are just like the similarly marked curves of Fig. 5; the two original potentials are in opposite phase.

Potential E_p of Fig. 9 acts in relation to potential E_b just as it acts in relation to potential E_a . All of the peaks for E_p occur at the same instants as the zero

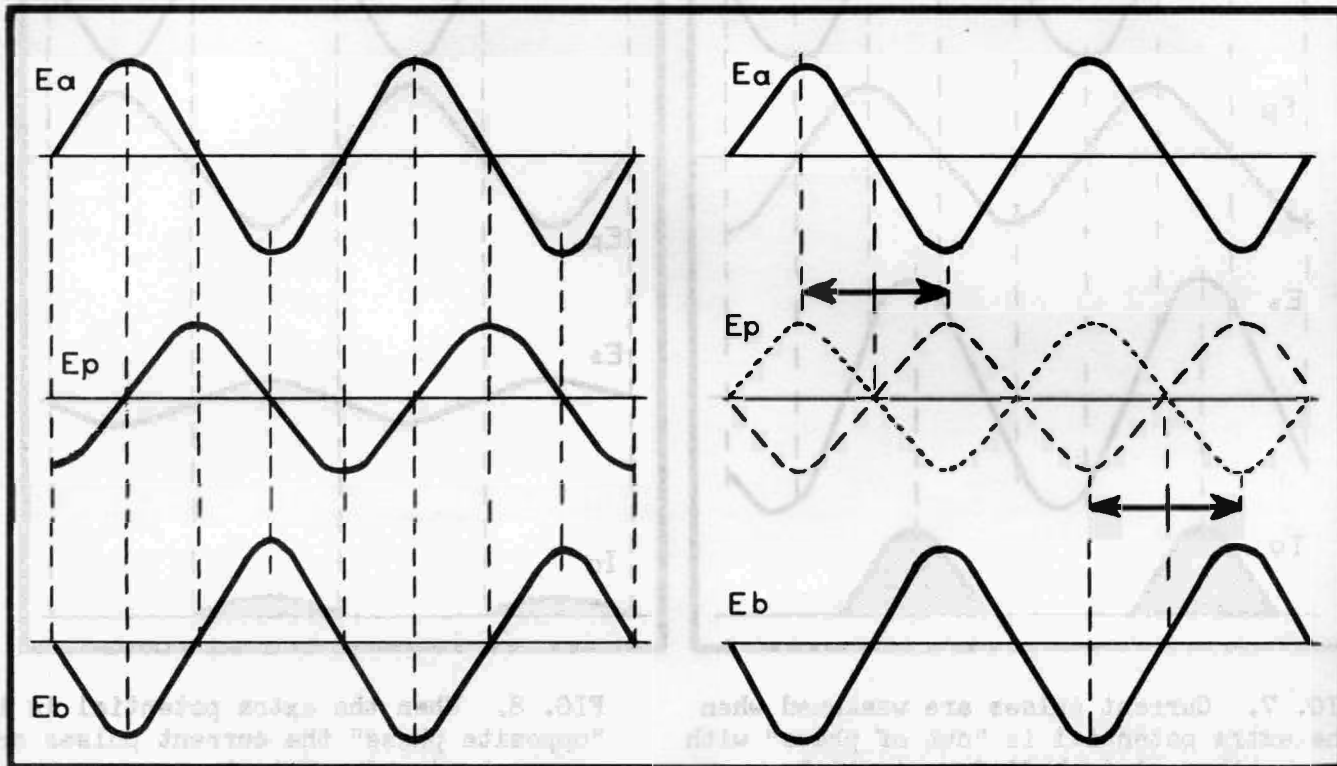

FIG. 9. Shifting the timing or phase of the extra potential will lessen the current in one diode circuit while increasing it in the other.

points for both E_a and E_b , and all of the zero points for E_p occur at the same instants as the peaks for both E_a and E_b . Then the current pulses in both diodes will correspond to those shown by Fig. 7.

If we shift the timing or phase of potential E_p of Fig. 9 in either direction, it will get farther out of phase with the original potential for one diode, but, at the same time, will get more nearly into phase with the original potential for the other

diode. In the diode for which the additional potential gets farther out of phase the pulses of current will become smaller, and in the diode for which the additional potential comes closer into phase the pulses of current will get larger.

If we find a means for shifting the timing or phase of the additional potential in accordance with deviations of frequency in the incoming signal we shall have a discriminator that works. The additional potential must be shifted to an earlier instant when the incoming frequency increases, and to a later instant when the incoming frequency decreases. This is going to be the easiest part of our whole problem, for in the plate circuit of the limiter there is a made-to-order potential with just the kind of phase shift needed.

OBTAINING THE PHASE SHIFT

At the left in in Fig. 10 is the tuned plate circuit of the limiter. The coil L is the primary winding of the transformer used between the limiter and discriminator stages. The coil is tuned to resonance at the intermediate frequency or center frequency by capacitor C . Although this circuit is tuned rather sharply to the exact

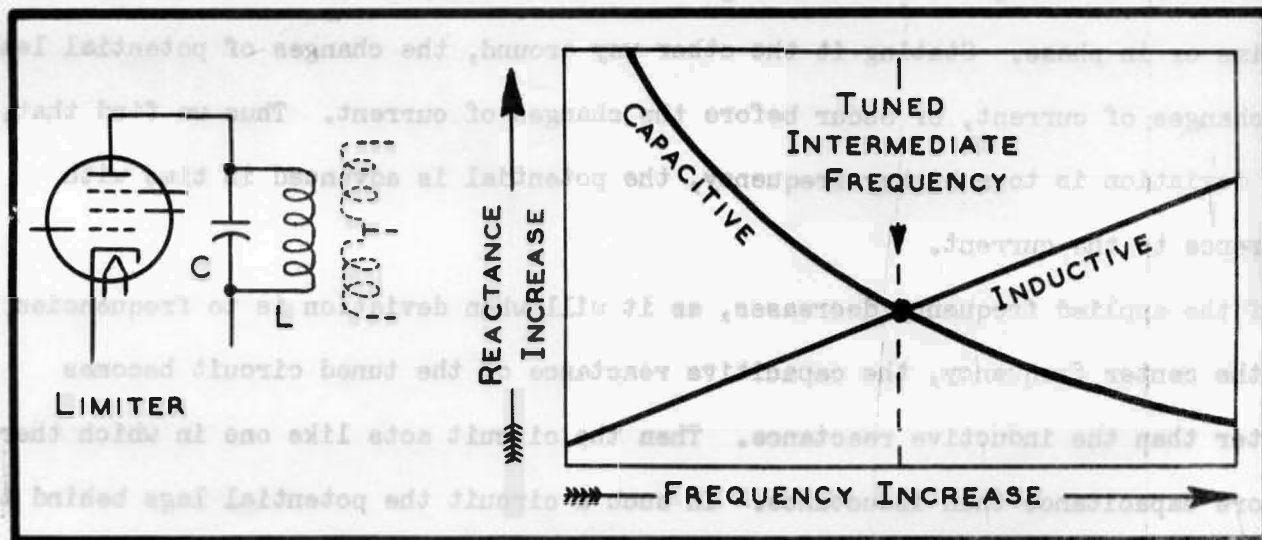

FIG. 10. The reactance effect in the limiter plate circuit changes from capacitive to inductive when the frequency increases.

intermediate frequency, the frequencies coming through the limiter tube deviate above and below the tuned frequency to an extent determined by the amount of deviation.

At the right in Fig. 10 are shown curves of the variations of capacitive reactance

and of inductive reactance in a tuned circuit when the frequency is varied. The inductive reactance, which is the reactance of the coil in the tuned circuit, increases steadily with rising frequency. The capacitive reactance, which is the reactance of the capacitance in the tuned circuit, decreases at a varying rate with rising frequency. At some certain frequency the two reactances become equal. Their effects in a circuit are opposite, and with them equal the effects balance and there is no reactive effect remaining. The only factor then limiting flow of currents in the circuit is that due to resistance and losses of energy or power.

Let's assume that the limiter plate circuit is tuned to the resonant frequency marked tuned intermediate frequency on the graph. Here the circuit acts as though it has neither capacitance nor inductance. But supposing that the applied frequency increases, as it will when the deviation is to a frequency higher than the center frequency. At this higher frequency the inductive reactance is greater than the capacitive reactance, as may be seen on the graph in Fig. 10. The circuit now acts as though it possessed extra inductance. In a circuit having more inductance than capacitance the changes of current lag behind the corresponding changes of potential in time or in phase. Stating it the other way around, the changes of potential lead the changes of current, or occur before the changes of current. Thus we find that, when deviation is to a higher frequency, the potential is advanced in time with reference to the current.

If the applied frequency decreases, as it will when deviation is to frequencies below the center frequency, the capacitive reactance of the tuned circuit becomes greater than the inductive reactance. Then the circuit acts like one in which there is more capacitance than inductance. In such a circuit the potential lags behind the current in time; the changes of potential occur later than the corresponding changes of current.

In the tuned plate circuit of the limiter we have a potential whose phase is advanced in time, with reference to the current, when the deviation is to a higher frequency. The phase of this potential is retarded, with reference to the same current, when the deviation is to a lower frequency.

The current of which we are talking is the current in the plate circuit of the limiter tube, and in the primary winding of the transformer between limiter and discriminator. This is the current whose changes induce the "original potential" referred to as potentials E_a and E_b in many preceding graphs. These induced potentials remain in time or in a fixed phase relation to the primary current. But the potential in the tuned plate circuit itself, which is not the potential induced in the secondary winding, this plate circuit potential varies its phase or timing in relation to the current and to the induced potential when the frequency deviates. The plate circuit potential which shifts its phase with deviation, is the potential referred to as E_p in preceding diagrams and graphs.

It is necessary only to get the phase-shifting potential from the plate circuit over into the diode circuits, where it will combine with the secondary induced potentials to vary the diode currents proportionately to frequency deviation. This may be done with a simple coupling capacitor C_c of Fig. 11.

In this circuit we have the conditions shown at the right in Fig. 9. Potential E_a is induced in winding section L_a , acts in the circuit containing diode A , and causes a potential drop across resistor R_a . Potential E_b is induced in winding section L_b , acts in the circuit containing diode B , and causes a potential drop across resistor R_b . The potential drops in R_a and R_b are of opposite polarity, as was shown in Fig. 3. When there is greater potential and current in the circuit for diode A the upper end of R_a , which provides input to the audio amplifier, will become positive and the lower end of R_b will become negative. When potential and current are greater in the circuit for diode B , the upper end of R_a will become negative and the lower end of R_b positive.

Potential E_p (Fig. 9) comes through coupling capacitor C_c of Fig. 11 to the center tap of coil sections L_a and L_b , and resistors R_a and R_b . Consequently, potential E_p acts in both diode circuits. As this potential E_p shifts in phase with frequency deviation it causes current to increase in one diode circuit and to decrease in the other diode circuit, depending on whether the deviation is to higher or lower frequencies.

Capacitor C_s of Fig. 11 tunes the circuit consisting of this capacitor and coil sections L_a and L_b . These coils are the secondary of the transformer whose primary is L_p , tuned by capacitor C_p . This transformer is called the discriminator transformer.

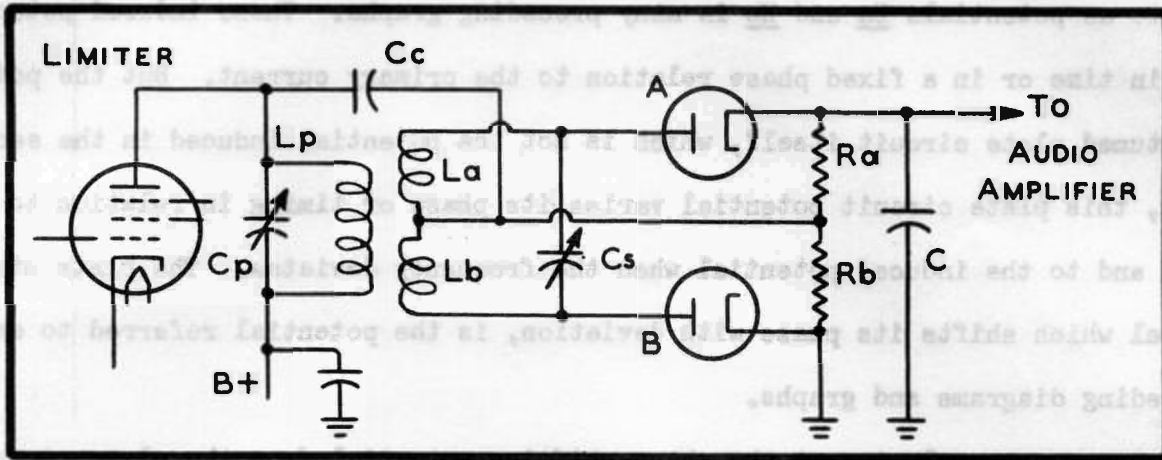

FIG. 11. The potential whose phase varies with deviation is introduced into the circuits of both diodes.

It has tuned primary and secondary, like all of the intermediate-frequency transformers. The lower ends of resistor R_b and capacitor C are electrically connected together through ground. Resistors R_a and R_b are called the discriminator load resistors.

When no deviation from the center frequency exists, when the frequency remains constant at the center value, there is no phase shift of the potential brought through coupling capacitor C from the limiter plate circuit. Then we have the condition represented by Fig. 7, with the timing of this additional potential (E_p) midway between the secondary potentials E_a and E_b . Then the total potential applied to one diode is just the same as to the other diode, there are equal and opposite currents and potential drops in resistors R_a and R_b , and there are no audio variations in the output to the audio amplifying system.

Were the input to the discriminator to remain at exactly the center frequency, but were the amplitude to vary at an audio frequency, no audio signal would get through the discriminator to be heard from the loud speaker. This is because, at the center frequency, the two diode circuits would be balanced and any increase of amplitude in one would be counteracted by an equal but opposite increase of amplitude in the other

diode circuit. Thus we find that, at the center frequency, amplitude modulation in the signal will not pass through the discriminator to the audio amplifier.

But were the frequency to go either above or below the center frequency value, there would be an excess of either inductive or capacitive effect in the tuned primary of the transformer. The diode potentials no longer would balance, and were the higher or lower frequency to have amplitude modulation, there would be audio-frequency potentials in the audio amplifying input and sounds would be heard from the loud speaker at the audio frequency of the amplitude modulation. Thus we see that amplitude modulation will go through the discriminator when there is frequency deviation.

DISCRIMINATOR CIRCUITS

As shown in circuit diagrams for receivers, the discriminator employing the principles just explained might appear as in Fig. 12. The various parts are lettered to correspond with similar parts in preceding diagrams, so that the principle may be

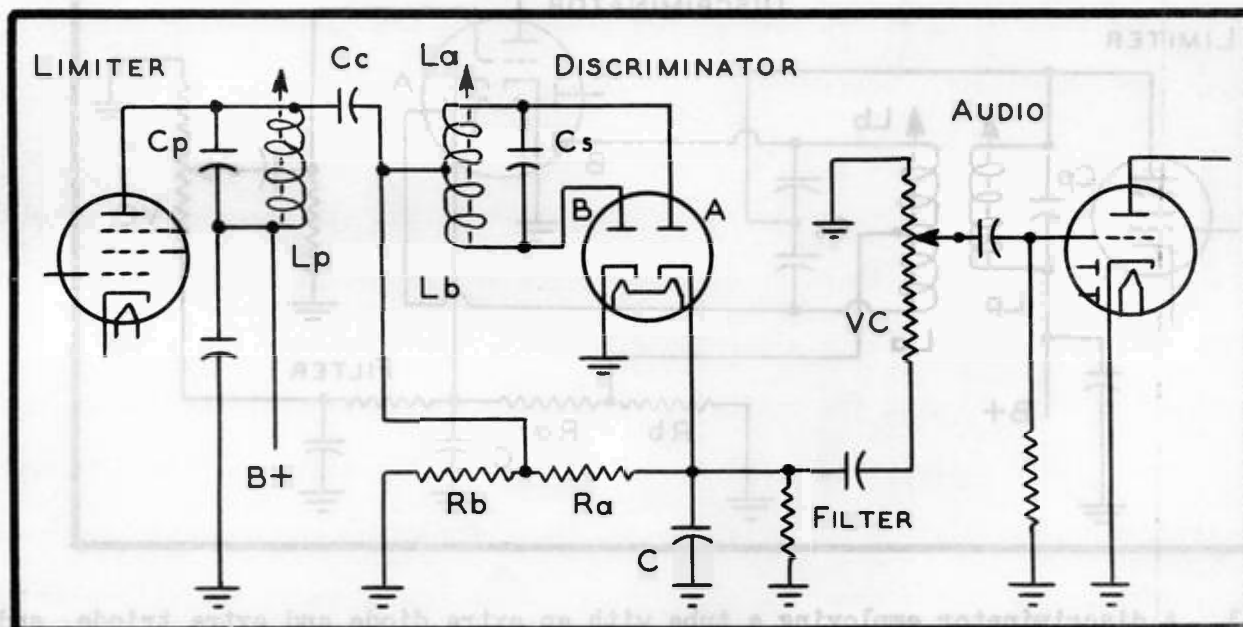

FIG. 12. The discriminator circuit for a practical f-m receiver.

recognized as unchanged in spite of the different arrangement of symbols. Windings Lp and La-Lb are variably tuned by movable powdered-iron cores instead of with adjustable trimmer capacitors. Tuning capacitors Cp and Cs are of fixed capacitance. Capacitor Cc is the coupling from the limiter plate circuit to the line running to the

centers between coil sections L_a and L_b , and between load resistor sections R_a and R_b . Instead of using separate diode tubes for the discriminator there is a single double-diode tube having separate plates and cathodes.

The audio-frequency output from the discriminator is taken from the cathode of diode section A , or from one end of resistor R_a through a resistance-capacitance filter to the lower end of the volume control unit VC . From the slider there is capacitive coupling to the grid of the audio amplifier tube. This tube is shown as a double-diode-triode type. The diode plates might be used for the amplitude-modulation detector and the automatic volume control system.

Another circuit arrangement which follows the same broad principles is shown by Fig. 13. Again windings L_p and L_a-L_b are tuned by adjustable powdered-iron cores and by fixed capacitors at C_p and C_s . Here the coupling from the limiter plate circuit to

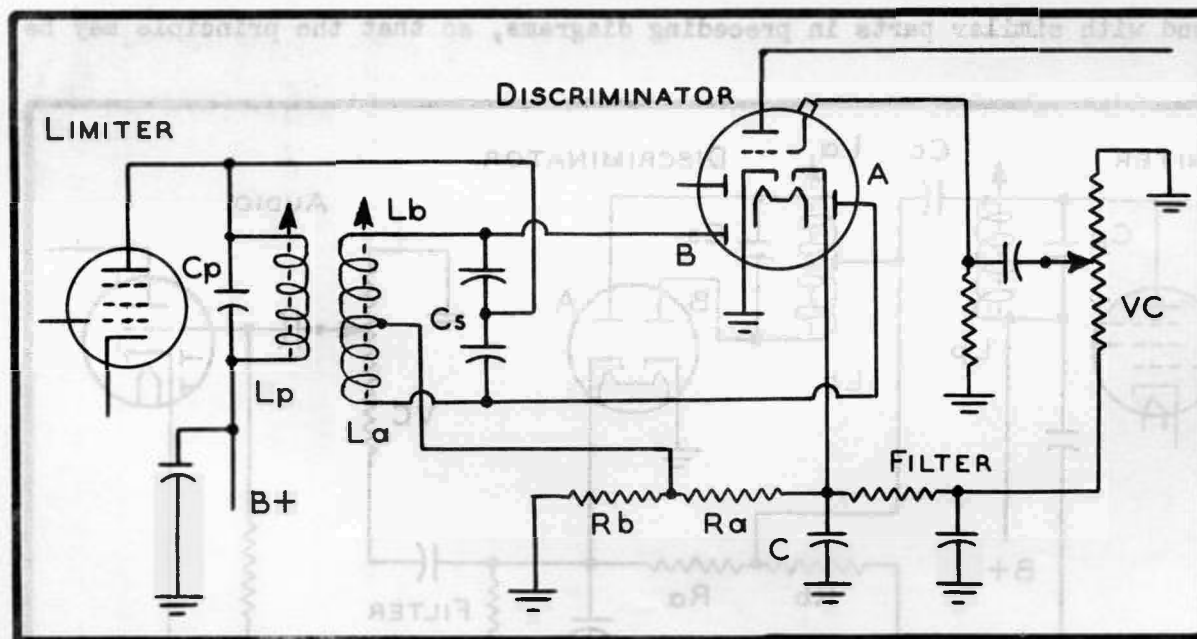

FIG. 13. A discriminator employing a tube with an extra diode and extra triode, and having coupling from the limiter plate through two capacitors.

the two diode circuits is through the two capacitors C_s , from a point between the capacitors to the diode plate connections. A center-tap from between winding sections L_a and L_b is connected to the center tap between resistors R_a and R_b . The discriminator tube has a single envelope within which are a triode and two diodes working from a single cathode, also a third diode working from a second cathode. One of the

diode plates and its cathode, A, is in the circuit with coil section La. Another diode plate and its separate cathode, B, is in the circuit with coil section Lb. The cathode for diode B is grounded, as is also the far end of resistor Rb and one side of capacitor C. The cathode for the other diode is connected to the near end of resistor Ra, capacitor C, and the filter leading to the audio amplifying system.

From the filter the output of the discriminator goes to the volume control unit VC, whose slider is resistance-capacitance coupled to the grid of the triode in the discriminator tube. This triode section is the first audio amplifier. The diode plate which is above diode B, and on the same cathode, is used for the amplitude modulation detector and for automatic volume control. In this one tube envelope we have a discriminator for f-m signals, a detector for a-m signals, a source of automatic-volume-control potential, and an audio amplifier.

Still another discriminator circuit is shown by Fig. 14. The identification letters in this diagram are the same as used in earlier diagrams for parts having

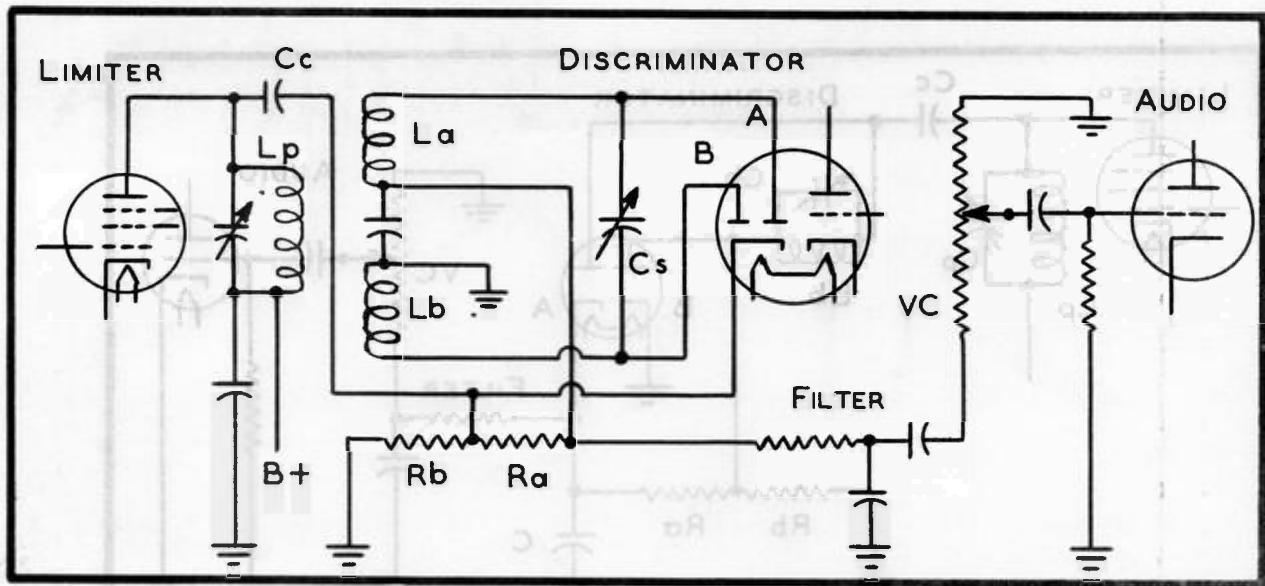

FIG. 14. A discriminator circuit in which both diode plates operate from the same cathode.

similar functions. Windings La and Lb are not conductively connected together but are joined at their adjacent ends through a capacitor which permits alternating potentials but not direct potentials to pass. The two windings are tuned by capacitor Cs. The

outer ends of these windings connect to diode plates A and B, as in other diagrams. But here we find that both diode plates operate from a single cathode, which makes it necessary to separate La and Lb with the capacitor to prevent a short circuit for direct current.

Coupling capacitor Cc brings potentials from the limiter plate circuit to a point between load resistors Ra and Rb, which point is connected also to the cathode for the two diode plates. The left-hand end of resistor Ra is connected through ground to the upper end of winding Lb, while the right-hand end of resistor Ra is directly connected to the lower end of winding La. Output to the audio amplifier is taken from the right-hand end of resistor Ra through a filter to the volume control unit VC. The triode which is shown in the same envelope with the diodes for the discriminator is used in the audio amplifying system.

In Fig. 15 is shown a method of using tuned impedance coupling between the limiter and the discriminator. The plate circuit of the limiter is tuned by the parallel resonant circuit consisting of winding Lp and adjustable capacitor Cp. All transfer

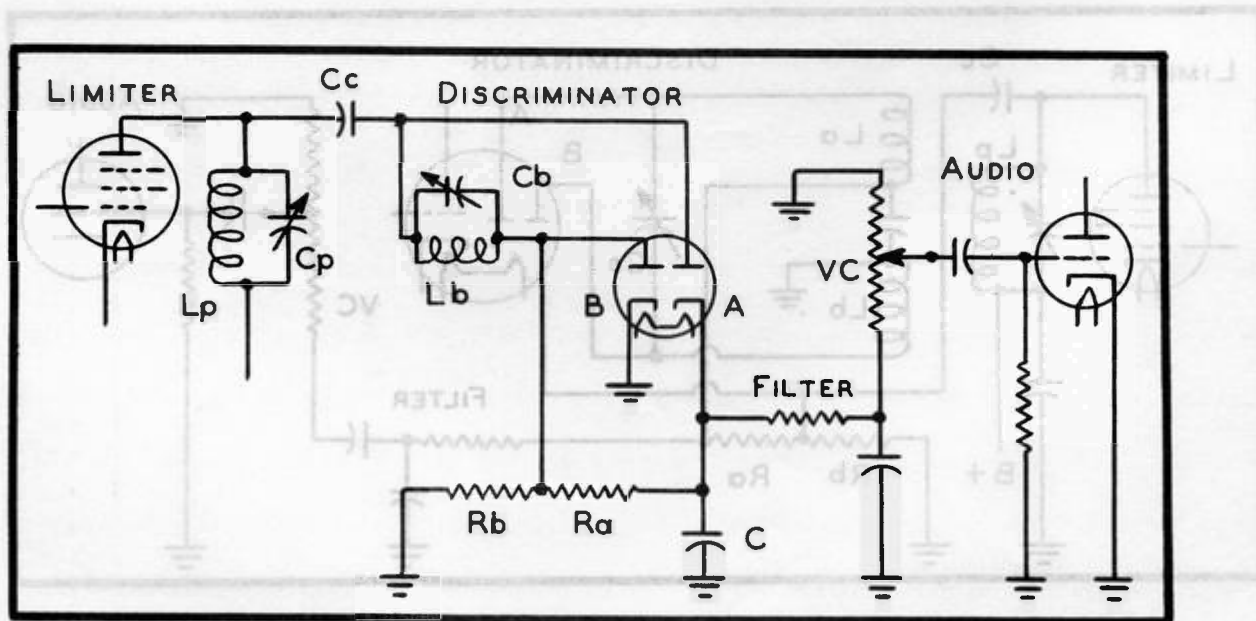

FIG. 15. A discriminator circuit in which a phase-shift potential is applied to one of the diodes.

of energy from limiter to discriminator is through coupling capacitor Cc. There is no transformer and no inductive coupling. Capacitor Cc is directly connected to the

plate of diode A, so that the phase or timing of potentials applied to this diode follows the timing of potentials in the limiter plate circuit.

Between coupling capacitor C_c and the plate of diode B there is a tuned resonant circuit consisting of winding L_b and adjustable capacitor C_b. This circuit is tuned to the intermediate frequency. When the incoming frequency deviates to a higher frequency the potentials in this tuned circuit are caused to lead the currents; the changes of potential occur earlier than the corresponding changes of current. When the incoming frequency deviates to a frequency lower than the intermediate, the changes of potential in L_b-C_b occur later than the corresponding changes of current.

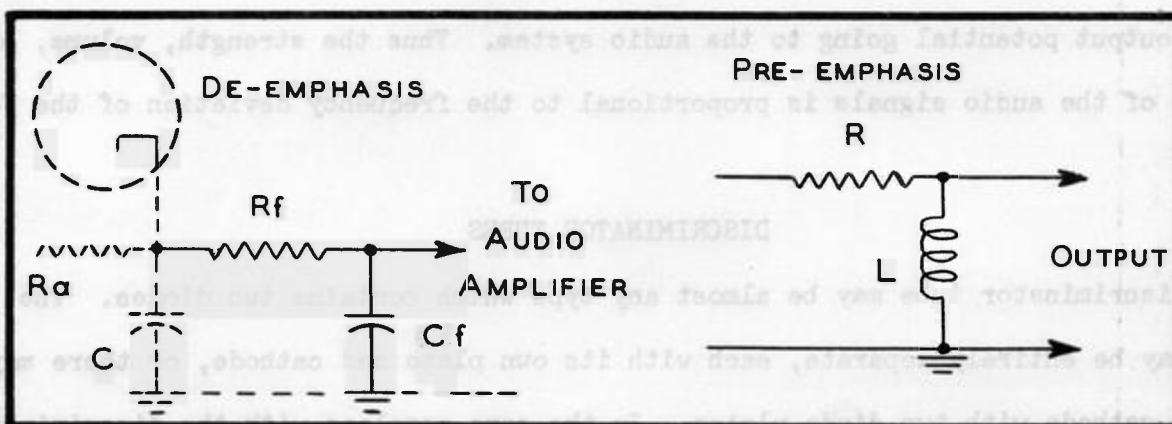

FIG. 16. De-emphasis at the receiver and pre-emphasis at the transmitter for the higher audio frequencies.

Consequently the potentials and currents in diode B and resistor R_b are displaced in time from those in diode A and resistor R_a when there are deviations of incoming frequency. As was shown in Figs. 3 and 4, the potentials in R_a and R_b are of opposing polarities, with the net potential difference across both resistors equal to the difference between the separate opposing potentials. Due to the shifting of phase with frequency deviation there is greater or less difference between the opposing potentials in the two resistors, and the overall potential difference varies with frequency deviation.

In all of the discriminator circuits examined there is utilized a shifting of phase or timing of one potential in relation to another potential, this phase shift occurring when the applied frequency deviates either above or below the tuned resonant

frequency, which is the center frequency or intermediate frequency. The two potentials combine their effects to vary the overall potential in accordance with the deviation of frequency. This overall potential then varies at the same rate as the applied frequency, which is the audio-frequency rate of the frequency modulation on the incoming signal. This audio-frequency potential, varying at the deviation rate, is the output potential of the discriminator circuit and is the input for following audio-frequency amplifying stages.

Since the phase shift of the diode potentials results from deviations of frequency, the extent of the shift will be proportional to the deviation. Greater deviation causes greater phase shift, a greater difference between the diode potentials, and a greater output potential going to the audio system. Thus the strength, volume, or loudness of the audio signals is proportional to the frequency deviation of the f-m signal.



DISCRIMINATOR TUBES

The discriminator tube may be almost any type which contains two diodes. The diodes may be entirely separate, each with its own plate and cathode, or there may be a single cathode with two diode plates. In the same envelope with the discriminator diodes may be other elements forming a triode or some other type used in the audio amplifying system, the amplitude-modulation detection system, the automatic volume control system, or for other functions.

In the circuits which have been shown by diagrams the discriminator diodes are represented as of the thermionic type, which means that the tubes have heated cathodes. Instead of thermionic diodes it is possible to use crystal diodes. The crystal diode looks much like a small cylindrical resistor of the pigtail type. It is a rectifier making use of the one-way conductivity characteristic of a crystal of germanium. The crystal diode operates satisfactorily at frequencies as high as 100 megacycles. It has the further advantages of compactness, of operation without a heater circuit, of ruggedness, and of a shunt capacitance which is only about three micro-microfarads.

The crystal diodes used for a discriminator cannot be made parts of a tube whose

other sections are used for other functions in a receiver. Therefore, when the discriminator diodes are incorporated in combination tubes which require heated cathodes for other functions, there would be no reduction in the total number of receiver parts, but rather an increase, and there would be no simplification of the circuits when using crystal diodes for the discriminator.

AUDIO AMPLIFIER CIRCUITS

The discriminator circuit diagrams in Figs. 12 to 15 show the first audio-frequency amplifying tube. Between the output of the discriminator, which is at the cathode end of load resistor R_a , and the control grid of the audio amplifier there are filter systems of the general type shown at the left in Fig. 16. These are called audio de-emphasis filters. Their purpose is to lessen the strength or amplitude at the higher audio frequencies.

You will recall that one of the advantages of frequency modulation is the transmission of audio frequencies which are higher than those which can be handled with amplitude modulation in the present transmission channels or band widths, and so it may seem rather peculiar that the higher audio frequencies are reduced in amplitude at the receiver. The reason is that the higher audio frequencies are over-strengthened at the transmitter, and reach the receiver with strengths which are too great in proportion to the lower frequencies. This action at the transmitter is called pre-emphasis. The principle of a pre-emphasis circuit is shown at the right in Fig. 16. In the pre-emphasis filter the inductive reactance of choke coil L increases with frequency. At lower frequencies much of the signal strength goes through the choke to ground, but as the frequency increases there is less and less loss through L , and more signal strength goes to the output. In the de-emphasis filter there is an opposite action. The reactance of capacitor C_f decreases with rise of frequency, and more and more of the signal strength goes to ground through this capacitor.

The reason for pre-emphasis at the transmitter is to reduce the effect of interference. Naturally there is less power or energy at the higher frequencies than at the lower ones. Increasing the amplitude at the higher frequencies brings it more nearly to the same level as the amplitude at the lower frequencies, thus raising the

total power or energy in the whole signal or in the whole range of audio frequencies without making the amplitude anywhere greater than it naturally is at the lower frequencies. Interference seems to be distributed about evenly throughout the whole range of frequencies, and anything which increases the power or energy in the entire f-m transmission helps to improve the ratio of the signal to the interference. Pre-emphasis and de-emphasis are applied in the audio frequencies above 5,000 cycles per second.

Because in many of the f-m transmitted programs there are represented audio frequencies all the way from 50 to nearly or quite 15,000 cycles per second, high quality f-m receivers are designed with audio amplifying systems which will amplify and reproduce this wide range. Degeneration is often used in the audio amplifier, especially in the output or power stage, to allow more uniform amplification throughout the range. Degeneration means a feedback of energy from plate to grid circuits in such polarity or phase relation as to lessen the gain at frequencies which naturally might have excessive strength. In some receivers there are two loud speakers, one especially adapted for reproduction of higher frequencies, and the other for lower frequencies. The high-frequency speaker, sometimes called the "tweeter" may be of the horn projector type, while the low-frequency unit, the "woofer", may be of the cone projector type. Suitable filters feed each speaker the frequencies which it is better able to reproduce.

When working with receivers designed for reception of both frequency-modulated and amplitude-modulated signals you will find it is a general rule to provide automatic volume control for reception of a-m signals but not for reception of f-m signals. The a-m automatic volume control gets its grid biasing potential from the circuit of the diode detector used in the a-m portion of the receiver, and when this detector is cut off for f-m reception there is no automatic grid bias for volume control.

The automatic volume control systems in general use act to make the grid bias more negative on r-f amplifiers, i-f amplifiers, and converters when there is an increase in the strength of the radio signal reaching the antenna. The automatic control acts when there is an increase of amplitude or of average amplitude in the received signal.

With the constant-amplitude signal used in f-m transmission such a control would not be operated. In the f-m receiver all variations of amplitude are presumed to be eliminated by the limiter stage. It is desirable that the input to the limiter reach the value at which limiting action commences when there is the weakest possible received signal. Any automatic volume control acting ahead of the limiter would make it necessary to receive a stronger signal to make the limiter operate, and on all signals

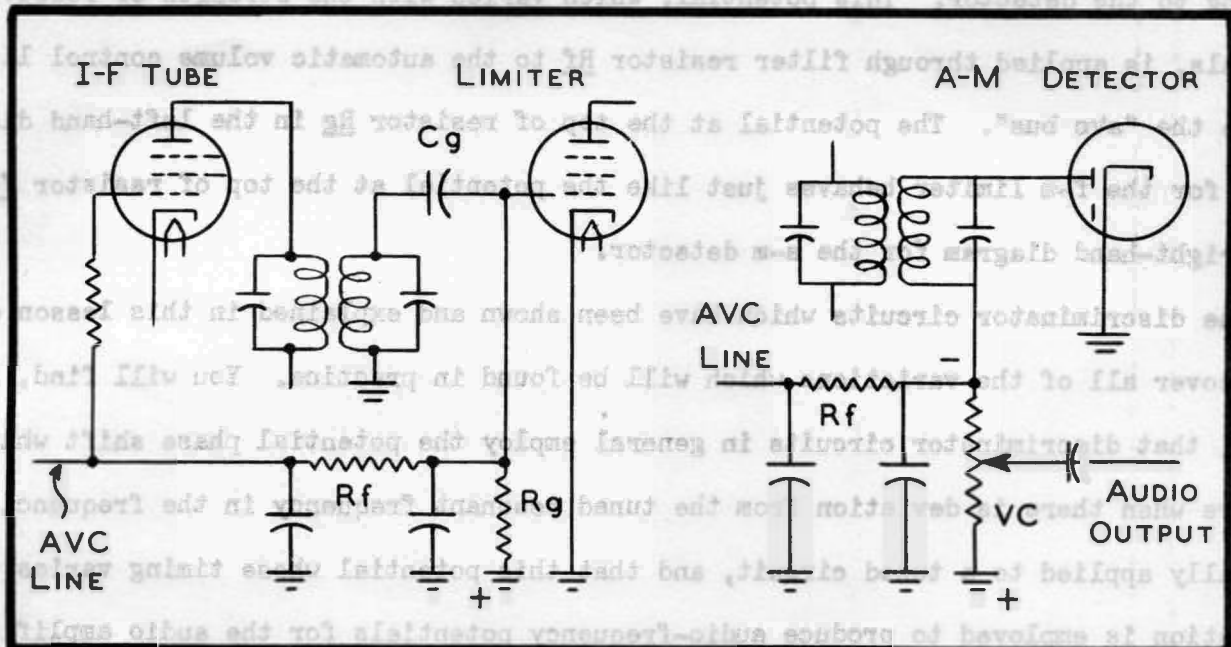

FIG. 17. Automatic volume control from the f-m limiter grid resistor (left) and from the a-m diode detector circuit (right).

below this level there would be amplification rather than limiting of amplitude variations.

EXAMINATION QUESTIONS ON NEXT PAGE

If automatic volume control is desired during reception of f-m transmissions the grid biasing voltage may be taken from the control grid end of the biasing resistor which is in the control grid circuit of the limiter. Such an arrangement is shown at the left in Fig. 17, where the grid biasing resistor is R_g and the biasing capacitor is C_g . At the top of R_g is the negative potential which is the grid bias potential for the limiter. This potential becomes more and more negative with increasing or decreasing strength of the i-f signal coming to the limiter, all as explained in the lesson explaining limiter action. This negative potential which varies with the incoming signal may be applied through a filter resistor R_f to the control

grids of any preceding amplifying tubes. In the diagram is shown the connection from this AVC line to the control grid of a preceding i-f amplifier tube. The stronger the signal the more negative are made the control grids of all controlled amplifiers.

At the right in Fig. 17 is shown, for comparison, the automatic volume control system usually employed with amplitude-modulation diode detectors. The potential at the top of resistor VC becomes more and more negative with increase of signal strength coming to the detector. This potential, which varies with the strength of received signals, is applied through filter resistor Rf to the automatic volume control line, or to the "avc bus". The potential at the top of resistor Rg in the left-hand diagram for the f-m limiter behaves just like the potential at the top of resistor VC in the right-hand diagram for the a-m detector.

The discriminator circuits which have been shown and explained in this lesson do not cover all of the variations which will be found in practice. You will find, however, that discriminator circuits in general employ the potential phase shift which occurs when there is deviation from the tuned resonant frequency in the frequencies actually applied to a tuned circuit, and that this potential whose timing varies with deviation is employed to produce audio-frequency potentials for the audio amplifier. The exact manner in which this is accomplished will be different in various makes and models of f-m receivers.

EXAMINATION QUESTIONS ON NEXT PAGE