

**LESSON  
46 RA**

# FURTHER DEVELOPMENT OF FREQUENCY CONVERSION



# RADIO-TELEVISION TRAINING SCHOOL, INC.

5100 SOUTH VERMONT AVENUE • LOS ANGELES 37, CALIFORNIA, U. S. A.

## FURTHER DEVELOPMENT OF FREQUENCY CONVERSION

FREQUENCY CONVERSION: Frequency conversion in superheterodyne receivers is the process of reducing the incoming R.F. signal to that of an intermediate frequency, and without any other modification of the signal. This intermediate frequency then is fed through an amplifier which is called an intermediate frequency amplifier where high signal amplification is possible with good selectivity, stability, and relatively low distortion. To perform this change, a frequency converting circuit is used consisting of a local R.F. oscillator and R.F. mixer or detector. The R.F. signal and the local oscillator signal voltages are applied to the input of the mixer or detector tube as shown in Fig. 1. Here a type 6L7 tube is used as a pentagrid converter. The

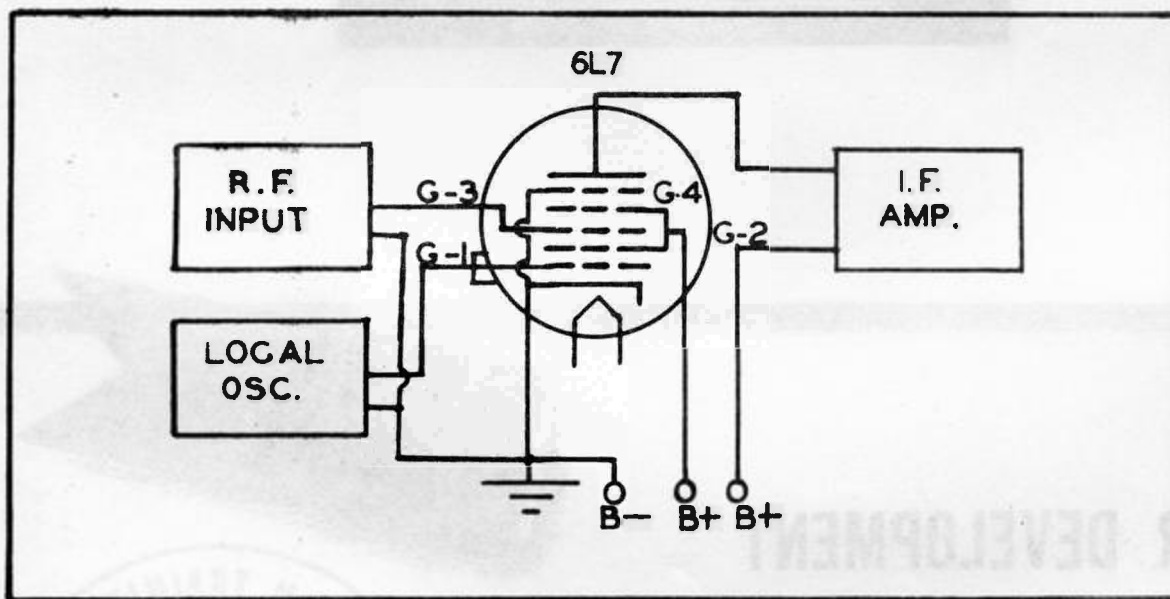

FIG. 1 A type 6L7 tube used as a pentagrid mixer.

local oscillator voltage, which is developed by a separate R.F. oscillator, is applied to grid G-1 and is of sufficient intensity to cause the amplified signal in the plate circuit of the type 6L7 tube to be about 10 times the intensity of the amplified R.F. signal. This ratio of oscillator to R.F. signal voltage has been found to be most desirable because mathematicians tell us, and

actual measurements show that under this condition of operation there is the minimum production of harmonic frequencies. It is, furthermore, easier to control the oscillator frequency and its output when it is oscillating strongly.

In Fig. 2 is shown the electrical components for a complete converter circuit employing a type 6L7-G tube and a type 6J5 tube where the first tube acts as the mixer or detector while the latter tube serves as the oscillator. The R.F. signal in the primary winding of the R.F. input transformer is induced into the secondary winding by induction. The secondary circuit of this antenna coupling transformer is tuned to resonance by the variable capacitor C-1. The voltage across C-1 is fed to grid G-1 of the type 6L7 tube.

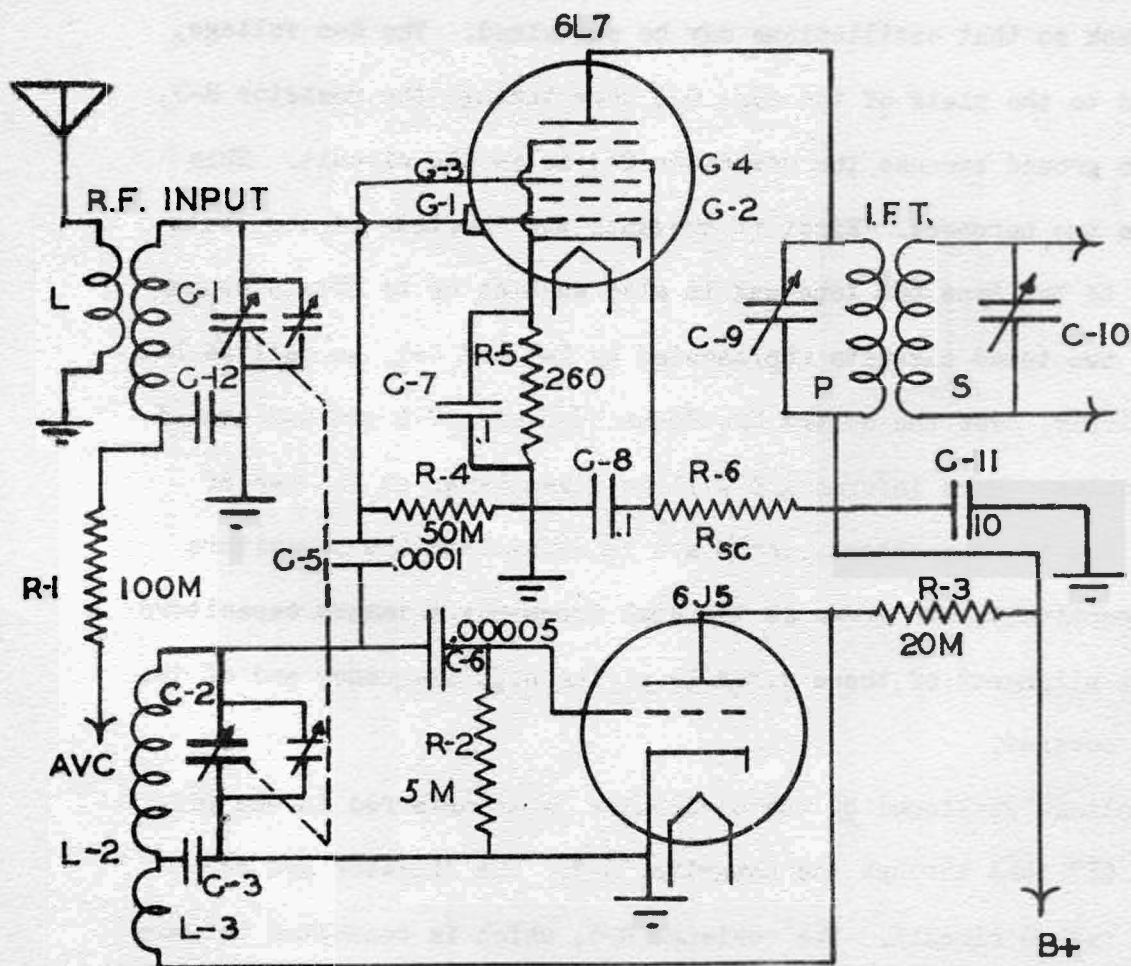

FIG. 2 A schematic diagram of a type 6L7 tube and a type 6J5 tube used as a pentagrid mixer and oscillator of a typical superheterodyne.

The R.F. input signal voltage is applied to grid G-1. This grid has remote cut-off characteristics and is especially suited for automatic volume control purposes. The local oscillator voltage is applied to grid G-3. This grid has a sharp cut-off characteristic and produces a comparatively large effect on plate current change for a small amount of oscillator voltage.

The rotor of the R.F. variable capacitor C-1 is mechanically coupled to the rotor of the oscillator variable capacitor C-2. It will be noted that the rotor of these two capacitors is connected to the chassis or ground circuit. The oscillator circuit formed by the capacitor C-2 and the winding L-2 is coupled to the grid of the type 6J5 tube through the grid coupling capacitor C-6. The resistor R-2 serves as the automatic bias supply for the oscillator tube. The winding L-3 is used for the purpose of producing the required feed-back so that oscillations may be sustained. The d-c voltage, which is applied to the plate of the type 6J5 tube through the resistor R-3, does not pass to ground because the capacitor C-3 is in the circuit. This capacitor serves two purposes. First it prevents the shorting of the plate voltage applied to the type 6J5 tube and it also enables us to obtain proper tracking of the two tuned circuits represented by L-1 and C-1, as well as L-2 and C-2 respectively, over the entire broadcast band when C-1 and C-2 are of similar construction. More information will be given later on the use of capacitor C-3. The two capacitors, which are in shunt with the capacitors C-1 and C-2 respectively, are known as the high frequency trimmers capacitors and enable exact alignment of these circuits at the high frequency end of the frequency range covered.

The R.F. voltage developed by the oscillator is transferred to the grid G-3 of the type 6L7 tube through the capacitor C-5. The resistor R-4 completes the grid return circuit. The resistor R-5, which is connected between the cathode of the type 6L7 tube and chassis, serves as the self-biasing

resistor. The capacitor C-7 is in shunt with this resistor for the purpose of providing a low reactance path for the R.F. signals in the circuit. The grids G-2 and G-4 are internally connected to pin 4 in the tube base. These grids prevent electrostatic coupling between grids G-1 and G-3 and may be referred to as the screen grid. This coupling is prevented by the use of the low reactance by-pass capacitor C-8 which allows the application of a d-c voltage to this important electrode of the tube. The resistor R-6 serves as the voltage dropping resistor to the screen grid of the type 6L7 tube. The capacitor C-11 provides a low reactance path for any amplified R.F. signals that may be present in this B plus supply lead. The capacitor C-12 and the resistor R-1 are used as an A.V.C. filter which permits the application of the negative a.v.c. voltage to the grid G-1 of the type 6L7 tube. The capacitor C-12 offers low reactance to R.F. frequency and does not affect the range covered by the coil and capacitor combination represented by L-1 and C-1.

The I.F.T., known as the intermediate frequency transformer, consists of the two tuned circuits C-9 and L-4, as well as C-10 and L-5, the latter being the secondary winding. These two circuits are tuned to the I.F. value and permit the desired signal to be applied to the grid of the first I.F. amplifier tube.

BROADCAST BAND FREQUENCY CONVERSION: When using a superheterodyne receiver for the reception of signals in the broadcast band, from 550 to 1,600 kc., the R.F. input tuned circuit will cover this frequency range. The local oscillator must cover a frequency range which is 455 kc. higher, that is,  $(550 + 455)$  1,005 kc. to  $(1,600 + 455)$  2,055 kc. as shown in Fig. 3 by curves 1 and 2. When receiving a signal from a station operating on 550 kc., and when the local oscillator is operating on 1,005 kc., two strong beats will be produced along with the oscillator signal of 1,005 kc. in the plate

circuit of the mixer or detector. One will be equal to 455 kc., the I.F. amplifier frequency which is often called the difference frequency and the other beat will be the 1,555 kc., known as the sum frequency. Then, of course, there will be the signal produced at the fundamental frequency of the local oscillator. Since the primary circuit of the first intermediate (I.F.) amplifier is tuned sharply to 455 kc., there will be no interference caused by the local oscillator and sum frequency in the plate circuit of the type 6L7 tube.

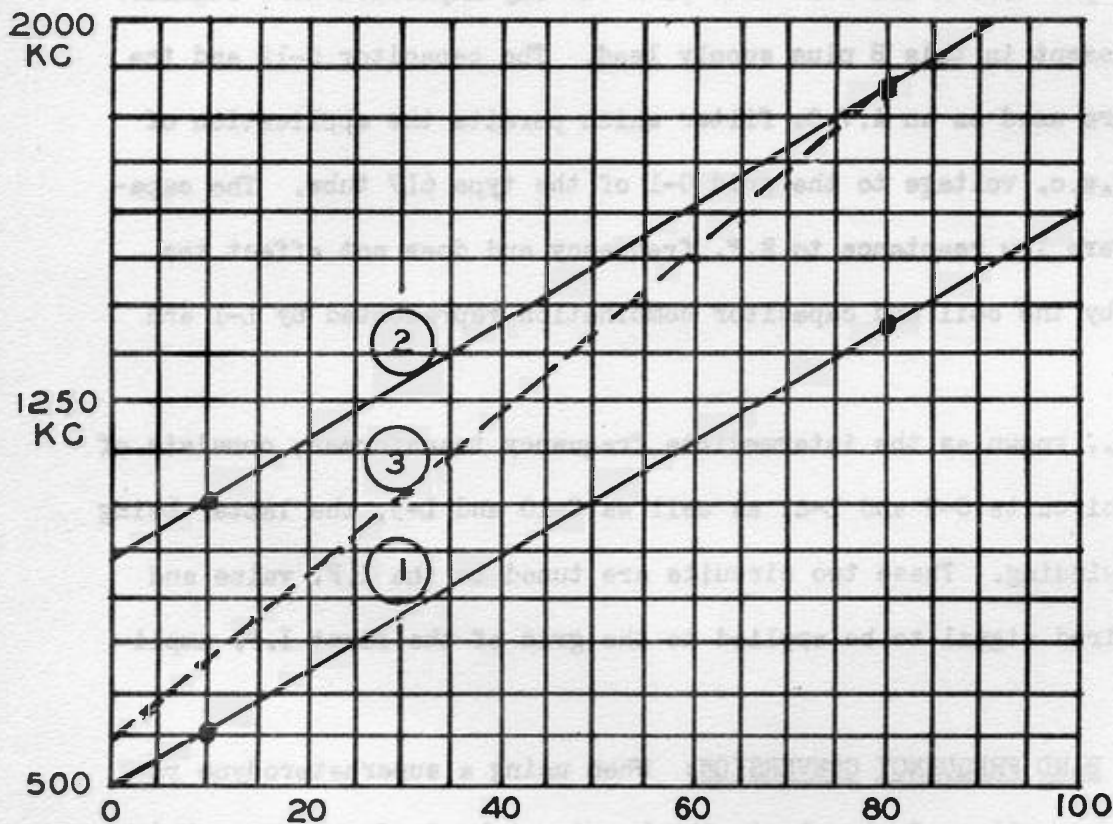

FIG. 3 A graph showing the tracking of the R.F. input and oscillator circuits.

TRACKING OF THE R.F. INPUT AND OSCILLATOR CIRCUITS: In order to obtain maximum selectivity and sensitivity from the R.F. input circuit, it is important that this circuit is always tuned to the desired station. Partial

tracking between the R.F. and oscillator circuits is made possible by the use of a dual variable gang capacitor electrically symbolized in Fig. 4. Here the two capacitors C-1 and C-2 have the same maximum capacity. Each capacitor has its small trimmer (screw driver adjustable) capacitors for exact tuning of these circuits at the high frequency end of the band. Let us assume that both the R.F. and local oscillator circuits are resonant at 80 degrees on the calibrated dial (see Fig. 3), that is, there is a difference in their resonant frequencies of exactly 455 kc. With this condition, maximum selectivity and conversion gain will be obtained.

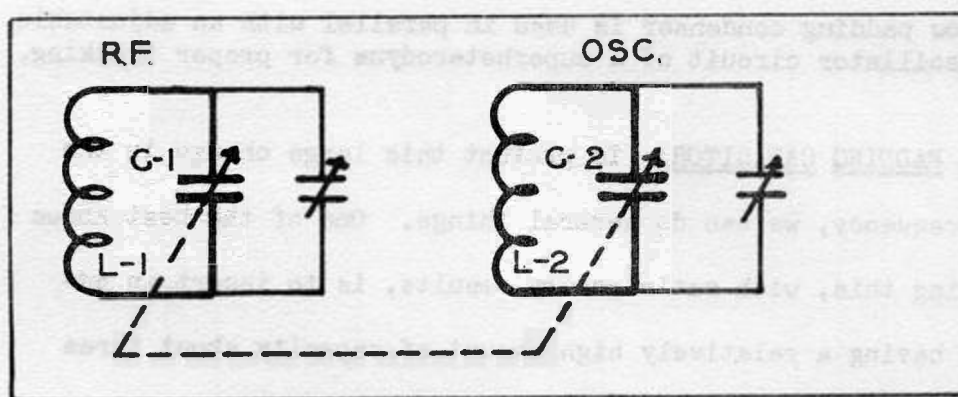

FIG. 4 Symbolizing electrical ganging of a dual variable capacitor with high frequency trimmer capacitors.

Now let's turn the dial for the reception of a station at the low frequency end of the band. With the dial set at 10, the R.F. input circuit (L-1 and C-1) will be resonant at a frequency of 580 kc., as shown by curve 1 in Fig. 3, however, look what happened to the resonant frequency of the oscillator circuit (L-2 and C-2); see curve 3. It is resonant at 885 kc. instead of  $(580 + 455) 1035$  kc., the required difference frequency to produce an I.F. valve of 455 kc. as shown by curve 3 in Fig. 3. The tremendous change in the frequency of the oscillator circuit (L-2 and C-2) is due to the fact that L-2 has about 30% less inductance than L-1 because the local

oscillator circuit is to operate at a much higher frequency than the R.F. input circuit.

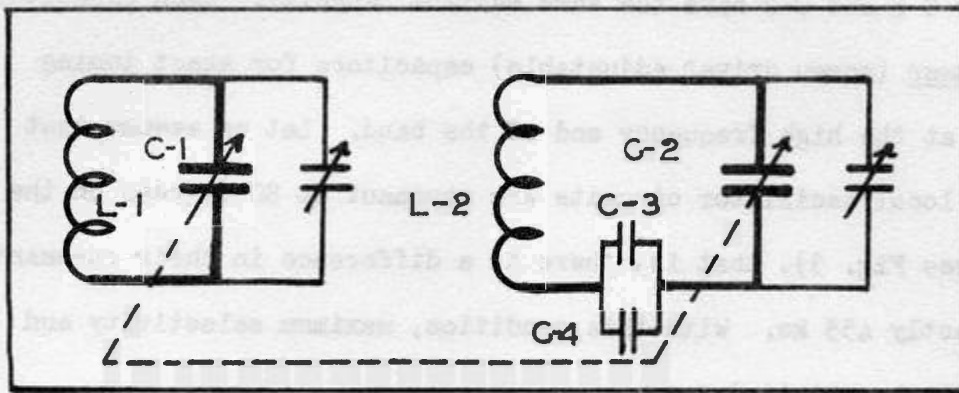

FIG. 5 A fixed low padding condenser is used in parallel with an adjustable capacitor in the oscillator circuit of a superheterodyne for proper tracking.

LOW FREQUENCY PADDING CAPACITOR: To prevent this large change in the local oscillator frequency, we can do several things. One of the best known ways of accomplishing this, with satisfactory results, is to insert an adjustable capacitor having a relatively high amount of capacity about three times the capacitances of C-2. The exact amount will be obtained when aligning a superheterodyne receiver employing a series low frequency padding capacitor (see Fig. 5). With the dial set to the desired station frequency of about 580 kc., adjust the series padding capacitor to cause reception of the desired station, that is, the production of the difference frequency of 455 kc. This will cause the oscillator resonant frequency to fall on curve 2 (see Fig. 3). This method of obtaining low frequency tracking has several disadvantages. Frequency drift of the oscillator is possible due to the changing of the capacity of C-3 and C-4 caused by a change in the operating temperature of the receiver parts. This generally causes improper tuning several minutes after the set has been turned on. The fidelity of reproduction will drop and even another station may be received with a reduction in conversion gain.

ALIGNMENT PROCEDURE USING A LOW FREQUENCY PADDING CAPACITOR: When employing padding, a special procedure for obtaining correct alignment over the



entire band is required. For example: Let's assume we have already adjusted the high frequency trimmer capacitors for the reception of a broadcast station operating at the high frequency end of the broadcast band, and with the dial calibration corresponding with the frequency upon which the station is known to be operating. Then we will turn the dial for the reception of a low frequency station operating on the known frequency of 580 kc. We will set the dial to the frequency calibrated on the dial for the station, or 580 kc., and adjust the low frequency padding capacitor C-4 for maximum volume and clear reception of the station. Now if capacitor C-4 required several complete turns, we will find that proper high frequency alignment will be no longer obtained. Now here's where most servicemen run into trouble, but don't let it disturb you. Merely repeat the original procedure of aligning the two circuits (L-1 and C-1) and (L-2 and C-2 with C-3 and C-4) at the frequency of a high frequency station operating on about 1400 kc.

ROCKING ADJUSTMENT: Rotate the dial to the low frequency setting of 580 kc. and adjust the series padding capacitor for maximum signal. Now try, what servicemen call, the rocking adjustment, setting the dial of the receiver first 10 kc. below, and then 10 kc. above the station frequency of 580 kc. and after each setting, adjust the series padding condenser for maximum a.v.c. voltage. This a.v.c. voltage can be measured several ways.

1. By measuring the d-c voltage across diode load resistor. The greater this voltage, the greater the conversion gain.
2. By measuring the voltage across the cathode self-biasing resistor of a R.F. or I.F. amplifier tube which is A.V.C. controlled. The greater the voltage, the greater the conversion gain.
3. By measuring the cathode to chassis current. The lower the current, the greater the conversion gain.
4. By measuring the plate current. The lower this current, the greater the conversion gain.

If we find that the conversion gain is higher at the 590 kc. setting of the dial, then we know the dial has slipped on its shaft or requires resetting. Before doing this, however, we should try the 600 kc. setting and make sure the point of maximum conversion gain has been obtained. Final setting of the shaft of the variable tuning capacitor will be where maximum conversion gain is obtained and when the dial is finally showing the correct calibration for both the high and low frequency broadcast stations. Before actually attempting this alignment procedure, you must be absolutely certain that the I.F. amplifier is tuned to 455 kc., the correct frequency for the receiver being aligned.

The process of aligning a superheterodyne is one that takes a little practice because there are a number of factors to be taken into consideration, each of which affect the other and naturally the over-all results received from a set of this type will also be affected. It takes experience to quickly determine what can be done to receivers in the various price ranges to improve their performances by aligning the circuits of the frequency converters.

CAPACITORS WITH SPECIAL CUT ROTOR PLATES: Many receiver manufacturers have found it more economical to use a dual variable capacitor that has the oscillator capacitor C-2 with special cut rotor plates as shown in Fig. 6. Fig. 7 is a picture of two dual ganged variable capacitors with special cut rotor plates for the oscillator circuit. Again high frequency trimmer capacitors are employed to provide high frequency alignment adjustments. Many manufacturers serrate the outer plates of the R.F. circuit capacitor as shown in Fig. 8. Exact alignment is obtained by bending the sections of the outer plate at A and B to, or away from the rotor plates a small amount. These sections cover the respective lower frequency portions of the range of frequencies covered. When bending the plates with parallel long nose pliers, it is

important that the dial is set on the proper dial calibration every time the conversion gain is checked.

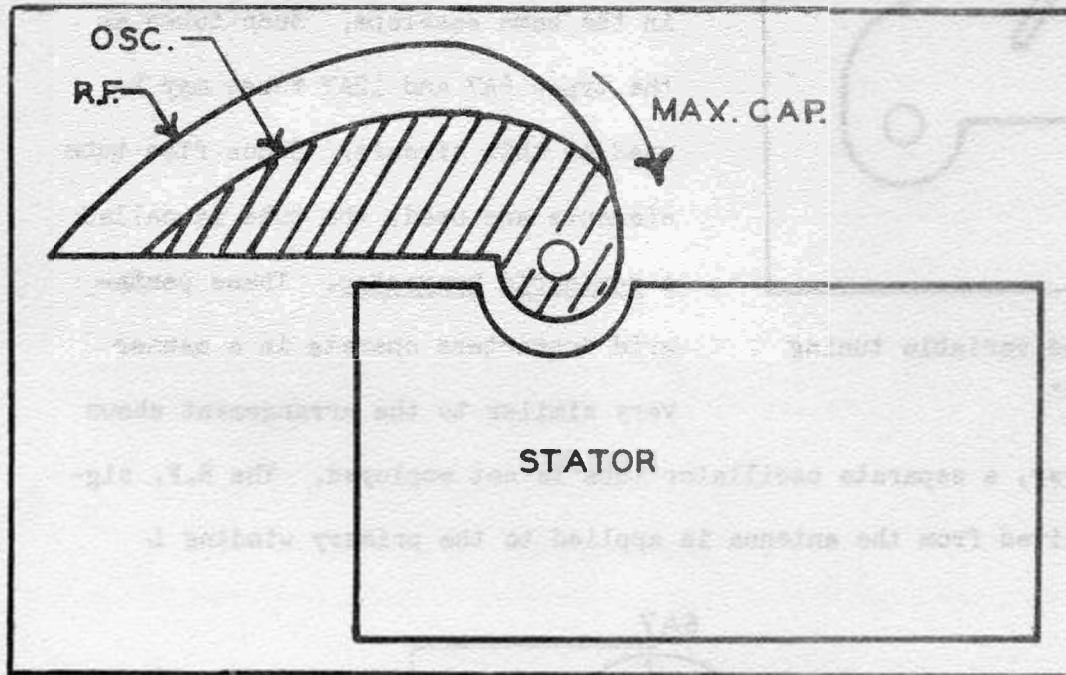

FIG.6 The shaded portion of the rotor of this dual ganged capacitor shows the relative size and amount of reduction in capacity of the oscillator tuning capacitor.

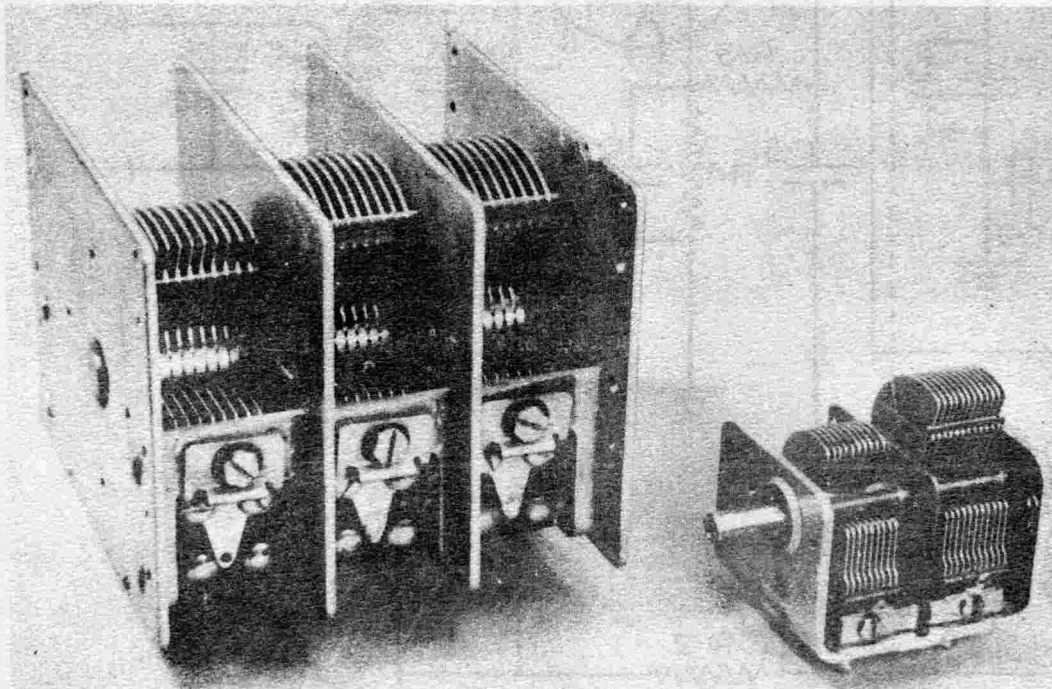

FIG. 7 A three-gang capacitor at the left, and a two-gang capacitor at the right, both with special shaped rotor plates and high frequency trimmer capacitors. The third section of the three-gang capacitor is used for tuning the first stage of R.F. amplification.

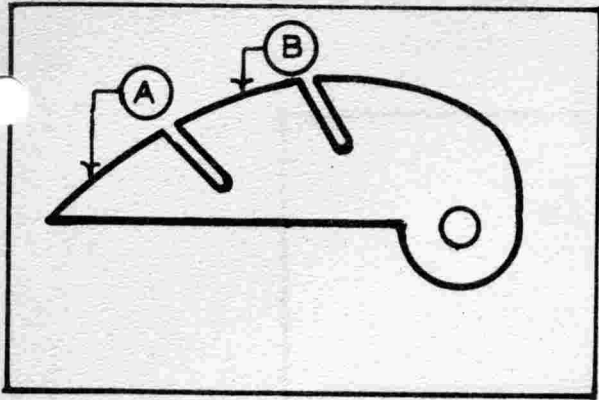

FIG. 8 Serrated variable tuning capacitor plates.

Fig. 9 shows a method of obtaining an oscillator and frequency mixer combined in the same envelope. Such tubes as the types 6A7 and 12A7 tubes may be used in this circuit. Since five tube elements are used, the tube is called a pentagrid converter. These pentagrid converters operate in a manner very similar to the arrangement shown

in Fig. 2, however, a separate oscillator tube is not employed. The R.F. signal voltage received from the antenna is applied to the primary winding L

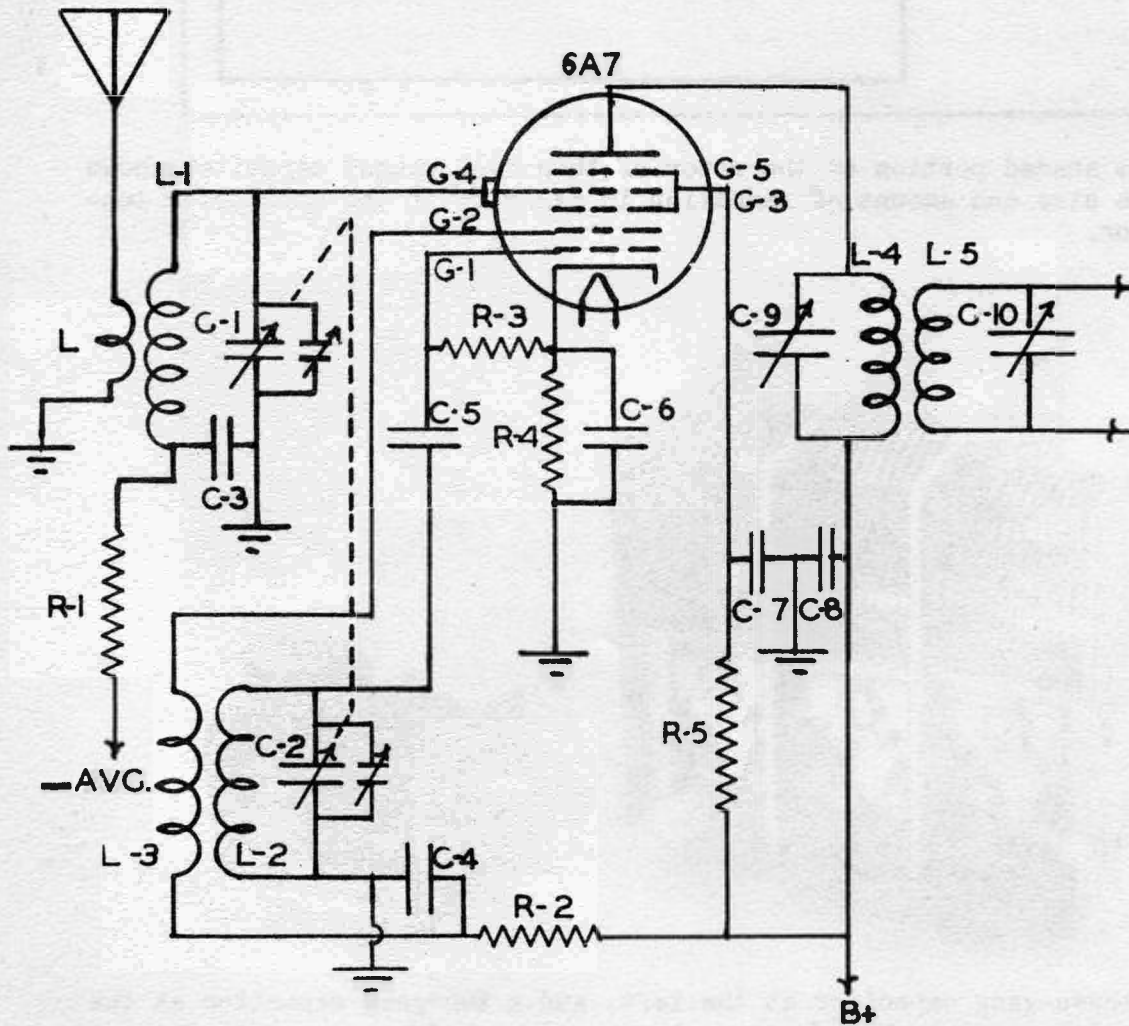

FIG. 9 An oscillator and mixer in the same envelope.

and induced in L-1, the secondary winding of the input transformer. This secondary winding is tuned to resonance with the incoming or desired signal by the R.F. section C-1 of the dual gang tuning capacitor. The capacitor C-3 serves as a means of applying the minus a.v.c. voltage to grid G-4 of the type 6A7 tube. This grid has a remote cut-off characteristic and is very satisfactory for use with receivers employing a.v.c. circuits. The resistor R-1 serves as the isolating or decoupling filter in conjunction with C-3, that is, R-1 and C-3 serve to isolate the low R.F. voltages that might exist across C-3 which has extremely low reactance to the R.F. voltages present in the resonant circuit formed by L-1 and C-1. Then, too, the resistor prevents any I.F. voltages that might be fed back from the diode load or a.v.c. voltage source from reaching the grid G-4 of the pentagrid converter tube.

The resistor R-4 serves as the self-bias resistor. The d-c voltage drop across this resistor is caused by the total current of all the screen grids and the plate electrode of the type 6A7 tube. The capacitor C-6 provides a low reactance path for all a-c currents in the cathode to ground circuit. Note that the resistor R-3 provides a D.C. return path for grid G-1 to the cathode. This grid serves as the grid electrode for the (triode) oscillator circuit of which grid G-2 is often referred to as the anode.

The capacitor C-5 serves as the coupling between the oscillator tank circuit formed by L-2 and C-2. Again C-1 and C-2 have high frequency trimmer capacitors for proper alignment of the two respective circuits in which they are placed. No low frequency padding capacitors are shown because the capacitor C-2 has tapered rotor plates.

The winding L-3 serves as the plate coil providing the necessary feedback voltage to sustain oscillations. The d-c supply voltage for the (anode) screen grid electrode G-2 of the type 6A7 tube is obtained from the most positive

terminal of the power supply through the voltage dropping resistor R-2. The capacitor C-4 provides the low reactance path required to make L-3 effective.

The d-c electrode voltage required for the screen grid G-3 is obtained through R-5. The capacitor C-7 provides the low reactance path for the a-c voltages in this circuit and also prevents electrostatic coupling between the grids G-2, G-4 and the plate electrode of the type 6A7 tube.

In the plate circuit of the type 6A7 tube is the I.F.T. or intermediate frequency transformer. The primary winding L-4 is tuned to the I.F. value by the adjustable capacitor C-9. The plate voltage is applied to the lower terminal of the winding L-4, and C-8 is used to provide a low reactance to all a-c signals that may exist in this circuit.

The coupling between the primary winding L-4 and L-5 is at an optimum value to give not only an efficient transfer of the desired signal voltage but also the required band width for the reception of the broadcast program. The capacitor C-10 tunes the secondary winding of the I.F.T. to the I.F. value.

THE PENTAGRID CONVERTER: The pentagrid converter is used extensively because it provides a high conversion gain without the necessity of special adjustments. The electron stream in the plate circuit and naturally the primary winding of the I.F.T., which is in series with it, are due to the combination of the oscillator and signal frequencies. The latter being the controlling element since G-4 receives the a.v.c. voltage. The grids G-3 and G-5 are connected together and also accelerate the electron stream and also shield grid G-4 electrostatically from the other electrodes.

Pentagrid-converter tubes are good frequency converting devices at medium R.F. frequencies but their performance is better at lower frequencies than at the higher ranges. This is because the output of the oscillator section drops down as the frequency is raised and further certain undesirable effects are

produced by inter-action between oscillator and signal sections of the tube increase as the operating frequency is increased. The transit time for the electrons to travel and the inductive properties of the leads to the respective electrodes in the pentagrid converter tube cause serious trouble at these high frequency ranges, however, in the broadcast band, very satisfactory results are obtained.

To minimize these effects at high frequencies, several of the pentagrid converter tubes are designed so that no electrode functions alone as the oscillator anode. In these tubes, grid G-1 functions as the oscillator grid, and grid G-2 is connected within the tube to the screen grid G-4. The combined two grids G-2 and G-4 shield the signal grid G-3 and act as the composite anode of the oscillator triode. Grid G-5 acts as the suppressor. Converter tubes of this type are designed so that the space charge around the cathode is unaffected by electrons from the signal grid. Furthermore, the electrostatic field of the signal grid also has little effect on the space charge. The result is that r-f voltage on the signal grid produces little effect on the cathode current. There is, therefore, little detuning of the oscillator by the a.v.c. bias because changes in a.v.c. bias produce little change in oscillator transconductance or in the input capacitance of grid G-1. Examples of the pentagrid converters discussed in this paragraph are the single-ended type 1R5 and 6SA7 tubes.

Another method of frequency conversion utilizes a separate oscillator having its grid connected to the grid G-1 of a mixer hexode. A tube utilizing this construction is the type 6K8. The top view of this tube is shown in Fig. 10. Here we can see the electrode arrangement. The cathode, triode grid G-1 and triode plate form the oscillator section of the tube. The cathode, hexode mixer grid G-1, hexode double screen G-2 and G-4, hexode mixer grid G-3 and hexode plate constitute the mixer section. The two internal shields are

connected to the shell of the tube and act as a suppressor for the hexode section. The action of the type 6K8 tube in converting a radio-frequency signal to an intermediate frequency depends on (a) the generation of a local frequency by the triode unit, (b) the transferring of this frequency to the hexode grid G-1 and G-3, the mixing in the hexode section of this frequency with that of the r-f signal applied to the hexode grid G-3.

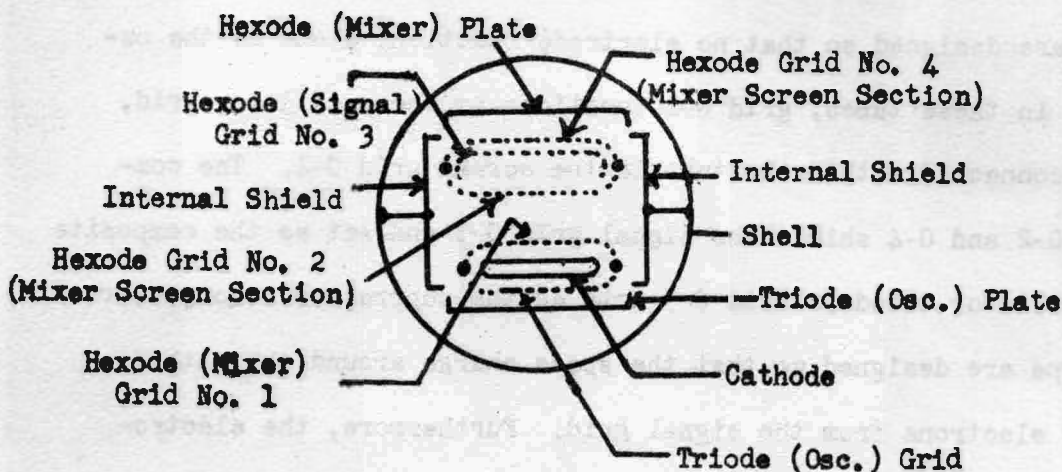

FIG.10 Top view of a hexode tube used in frequency converters.

The type 6K8 tube is not critical to changes in oscillator-plate voltage or signal grid bias and, therefore, is used in all-wave receivers to minimize frequency-shift effects at the higher frequencies.

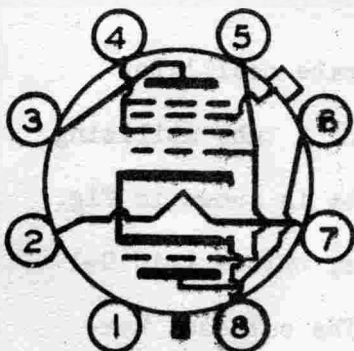

FIG.11 The socket or base connections for the type 6K8 tube are shown to the left. Pin 1 is the metal envelope, Pin 3 is the hexode plate, Pin 4 is the hexode screen grid, and Pin 5 is the connection to the first grids of the triode and hexode sections. The cap is the hexode grid. Pin 6 is the plate of the triode section. Pin 8 is the common cathode.