

MIDGET RADIO RECEIVERS

**LESSON
44 RA**



RADIO-TELEVISION TRAINING SCHOOL, INC.
 5100 SOUTH VERMONT AVENUE • LOS ANGELES 37, CALIFORNIA, U. S. A.

MIDGET RADIO RECEIVERS

The midget radio set, so-called on account of its small size, represents an individual style of design and construction. Midget radio sets operate on the same radio circuit principles as the larger sets do, but are of very compact construction and are housed in relatively small cabinets that require a rather condensed arrangement of chassis and speaker.

Although the early midget sets were not very efficient in performance and lacked much that could be desired in tone quality, really remarkable results are being accomplished by the designers in the modern midget sets. Sensitivities nearly as high as those of the larger sets are produced, and the tuning performance also compares favorably. Of course, the elevation of the midget set to this high standard has in turn been due to the development and perfection of the high-amplification screen grid and variable- μ radio frequency tubes, and to the more sensitive high-power output pentodes. Improvements in dynamic speaker design, especially in the more compact forms with the smaller cones, have added greatly to the tone quality. Other factors that contributed to the success of the midget set are the small size dry electrolytic filter condensers, improved rectifier and voltage doubling tubes, more compact tuning condensers, etc.

The circuit systems employed in midget sets have also undergone great changes as improved tubes and better tuning apparatus became available. From simple tuned radio frequency systems the circuits have changed to complex super-heterodynes with automatic volume control and universal operation of both A.C. and D.C. power lines.

THE EARLY MIDGET SETS

The earliest midget sets comprised a miscellaneous group of small A.C. operated receivers, crude in both construction and performance. They were built

of parts intended for the regular large sets, and were awkward and clumsy, quite different from the clock-like precision found in the modern midget receiver. Although they were seriously lacking in sensitivity and selectivity and delivered a poor tone quality even for their day, they did introduce a radically new design for radio receiving sets.

The introduction of the modern screen grid tubes with their greater amplification possibilities, created a new interest in small receivers and it is then that the real midget radio set came into being. In addition, special parts were made available for midget construction, such as smaller shielded coils, more compact tuning condensers, power transformers, dry electrolytic filter condensers, etc. Some of these midget sets at first employed magnetic speakers, but practically all of them were soon equipped with dynamic speakers, which were quickly produced in suitable smaller sizes.

These midget sets were all of the tuned radio frequency type with one or several stages of tuned radio frequency amplification, a power detector, an audio power stage, and a rectifier with its associated filter and voltage divider systems. It seems that the mantel clock type of cabinet was adopted almost universally for these midget sets, for it provided a convenient arrangement for the speaker in the upper part and the chassis in the lower part of the cabinet. Various modernistic cabinet designs were also used later on, but the mantel clock type remained the most favorite.

THE ZANEY-GILL AND JACKSON-BELL MIDGET SETS

One of the first successful midget sets placed on the market was the Zaney-Gill Model 54 made in California. This was a 6-tube receiver housed in a small mantel clock type cabinet. As is illustrated in Fig. 1, the circuit employs three stages of tuned R.F. amplification with type 24 tubes, a power detector

with a type 27 tube, and a power output stage with a type 45 tube. The power supply system, equipped with a type 80 rectifier, is of standard design and construction. A dual volume control unit is used, one section of which controls the bias of the 1st R.F. tube and the other the antenna signal input. There is nothing unusual or special about the circuit system, for it is a straight tuned R.F. arrangement; but mechanically the set is quite singular on account of its compact construction. It was the first attempt to build an entire radio set into a small portable cabinet.

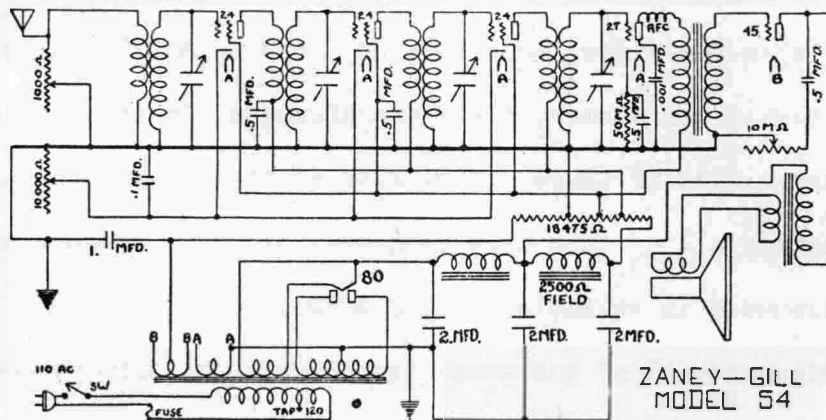

Fig. 1

The Jackson-Beli Model 63 and 64 midget receiver, also made in California, was released at about the same time. It also was a 6-tube set with three tuned R.F. stages and a power detector, all using type 24 tubes, and an audio output stage with a 45 tube. The circuit is illustrated in Fig. 2. An important feature is the use of three 7- μ mfd. balancing or coupling condensers in the R.F. stages. These must be accurately balanced in order that the R.F. amplifier can function with maximum gain and selectivity. The power supply also contains a few variations from standard practice. A special filter choke is used in the plate circuit of the detector to minimize the A.C. hum.

The Zaney-Gill and Jackson-Beli midgets set up a new style in set construction

that received quick reception from the public, and soon a host of other midget sets appeared on the market, some engineered excellently and others not so well. These midgets ranged from 4, 5, and 6-tube to 8-tube sets.

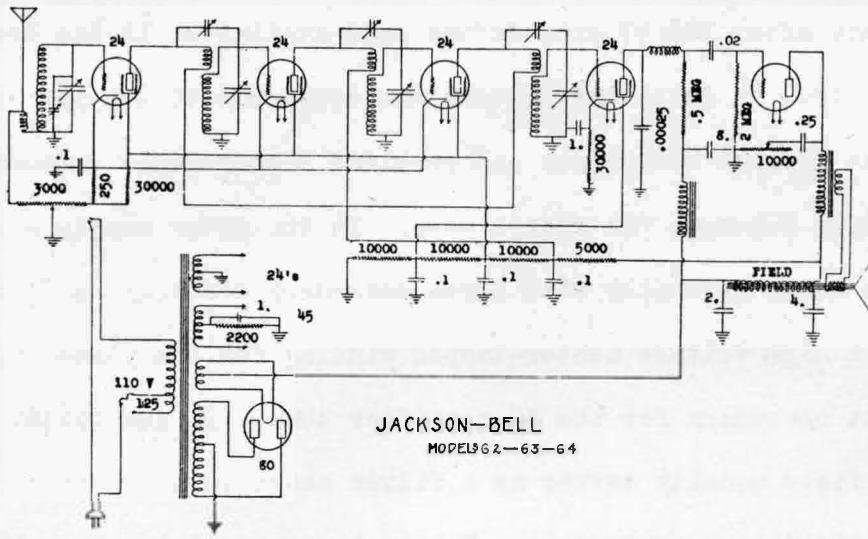

Fig. 2

FOUR-TUBE MIDGETS

Most of the cheaper midget sets were of the 4-tube style; and although the basic circuits used in most of them were much alike, they differed only in some minor respects such as the method of volume control, the system of biasing, etc.

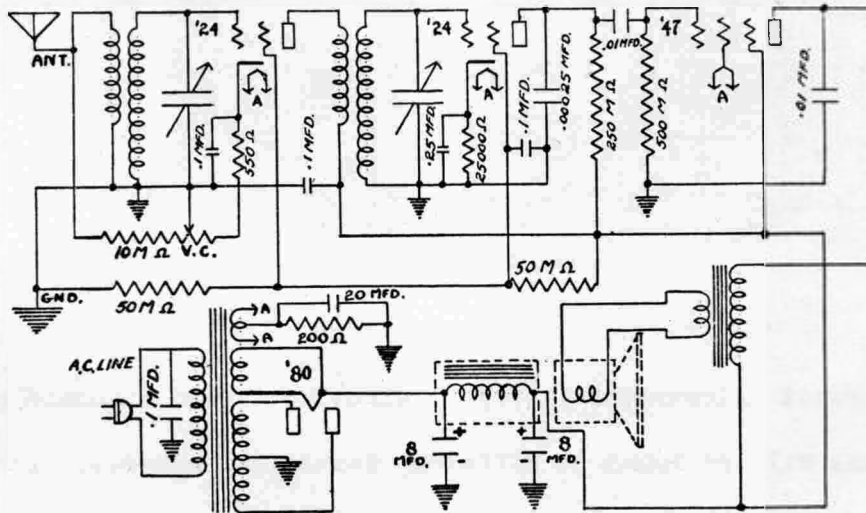

Fig. 3

A typical 4-tube midget circuit is illustrated in Fig. 3. There is a tuned R.F. stage usually with a type 24 or 35 tube, a power detector using either a type 24 or 27 tube, and an audio output stage. At first the 45 tube was used as an output tube; but after the 47 pentode was made available, it has been used almost exclusively. In fact, the pentode was developed to provide an output tube that operated at greater efficiency and provided higher audio gain--two important and desirable features for midget sets. In the power supply a small power transformer is used, generally with three secondary windings, a 2½-volt filament secondary, a high voltage center-tapped winding for the plate supply, and a 5-volt filament secondary for the 80 rectifier tube. In the filter circuit the speaker field usually serves as a filter choke in conjunction with two 8-mfd. electrolytic filter condensers. Volume is controlled with a 10,000-ohm potentiometer connected in series with a 350-ohm bias limiting resistor between the antenna and 1st R.F. cathode. This controls both the signal strength input and the bias on the R.F. tube, a very satisfactory method.

SOME VARIATIONS IN CIRCUIT PRACTICE IN 4-TUBE MIDGETS

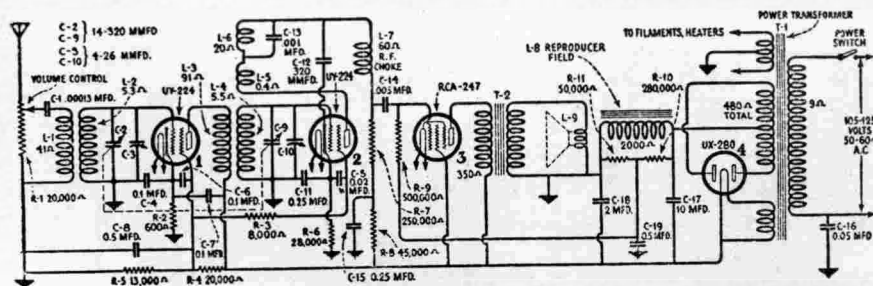

Fig. 4

Although the circuit illustrated in Fig. 3 might be termed standard practice, a number of variations will be found in different commercial midgets. In some

coupler is of the auto-transformer type, but the rest of the system is of standard design. Most midgets using a type 47 output pentode have a .01 fixed condenser connected between plate and ground to prevent an over emphasis of the high frequencies.

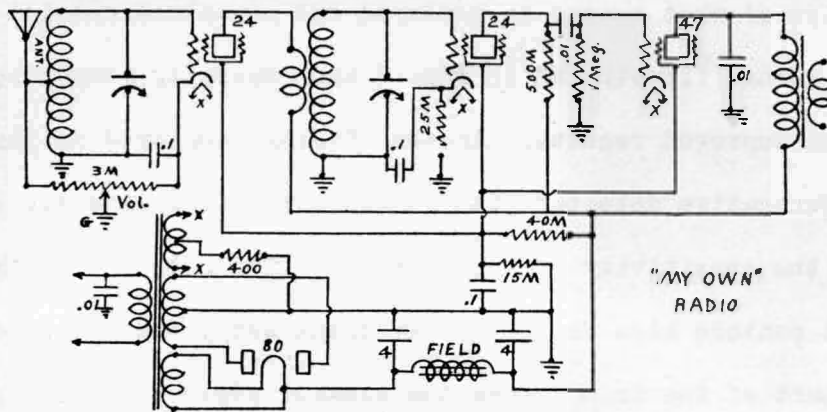

Fig. 6

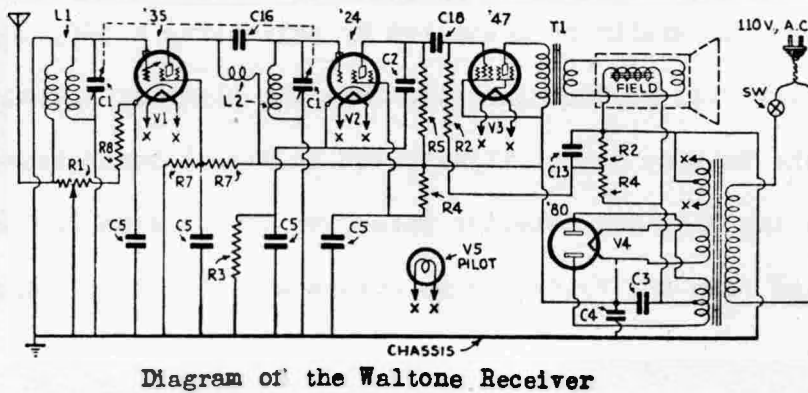

Diagram of the Waltone Receiver

Fig. 7

FIVE-TUBE MIDGETS

The 5-tube midgets comprise probably the largest group of midget receivers. Although many circuit variations will be found among the early sets, the basic circuit employed in practically all includes two stages of tuned R.F. amplification using type 24 or 35 screen grid tubes, a power detector with either a 27 or 24 tube, and an audio output stage equipped with either a type 45 or 47 power tube. Some sets use two power tubes in push-pull to obtain a greater power

output and also to increase the number of tubes, but essentially they are 5-tube circuits. The power supply and filter systems are much like those of the 4-tube sets, except that the power transformer must be larger so as to be able to provide for the additional tube. Mechanically the construction is also similar to that of the 4-tube sets.

The two points in favor of the 5-tube midgets are their higher sensitivity and improved tuning selectivity. Little thought was given to sensitivity in the early midget sets, but as the technique improved in building the sets, sensitivities ranging from 20 to 50 microvolts were developed in them. Better speakers were also made available, with the results that soon the midget sets became quite easy to listen to. After all, a midget is merely an undersized radio set, and in view of the rapid advances that were made in the radio art, midget construction also improved with most of the later developments incorporated in them.

A REVIEW OF SOME COMMERCIAL 5-TUBE MIDGETS

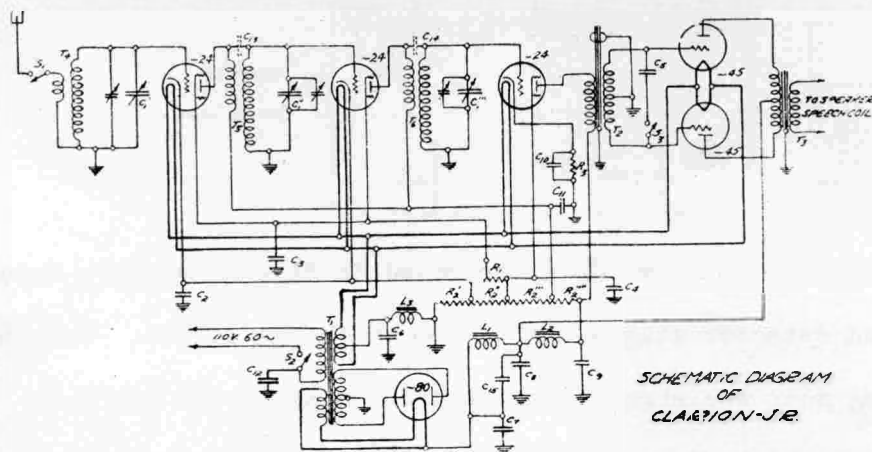
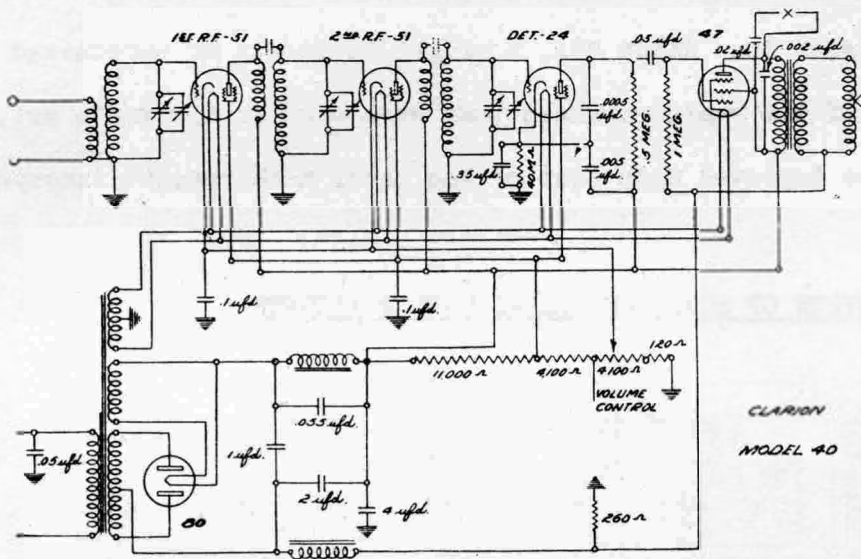

Fig. 8

A large number of 5-tube midgets have been developed and placed on the market, each displaying certain circuit features and yet all built around the same basic circuit. The Clarion Model 40 5-tube midget illustrated in Fig. 9,

might probably be considered as a typical or standard circuit. It is a straight tuned R.F. system with a power detector and resistance coupled output stage equipped with a type 47 pentode. The bias for the output tube is obtained by means of a resistor in the negative B return line. Volume is controlled by varying the cathode bias on the two R.F. tubes. The speaker field serves as a second filter choke in the negative B line.

The Clarion Jr. illustrated in Fig. 8 really preceded the model 40. The circuit arrangement is very similar except that type 24 tubes are used in the R.F. stages and two type 45 tubes in push-pull in the output stage. Although 6 tubes are used, it is basically a 5-tube system.



The U.S. Radio & Television Model 26 illustrated in Fig. 10 employs type 24 tubes in the R.F. and detector stages and a type 45 in the output. Volume is controlled by varying both the signal input and the bias on the two R.F. tubes. Model 26P illustrated in Fig. 11 is very similar, except that a type 47 pentode is used in the output stage. In both of these models some service trouble has been experienced with the bypass condensers, all of which are

mounted in one can. Model 27 illustrated in Fig. 12 is similar to Model 26 except for the indicated changes.

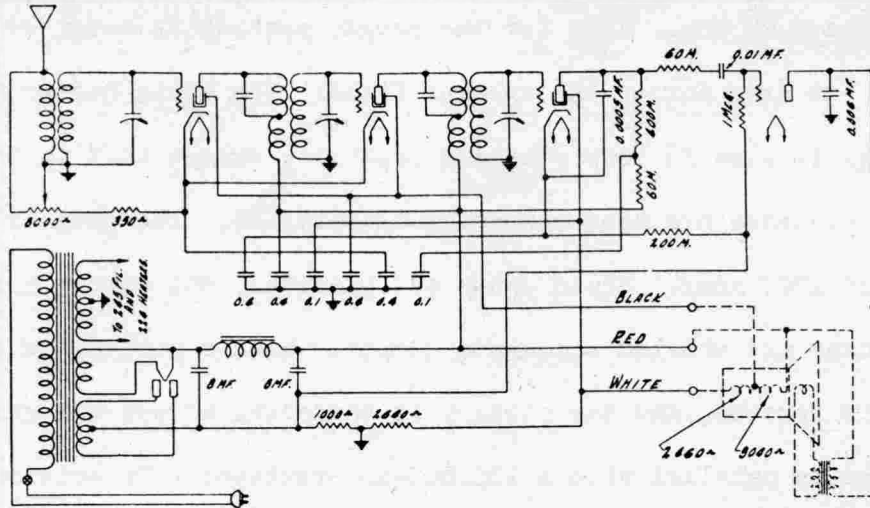
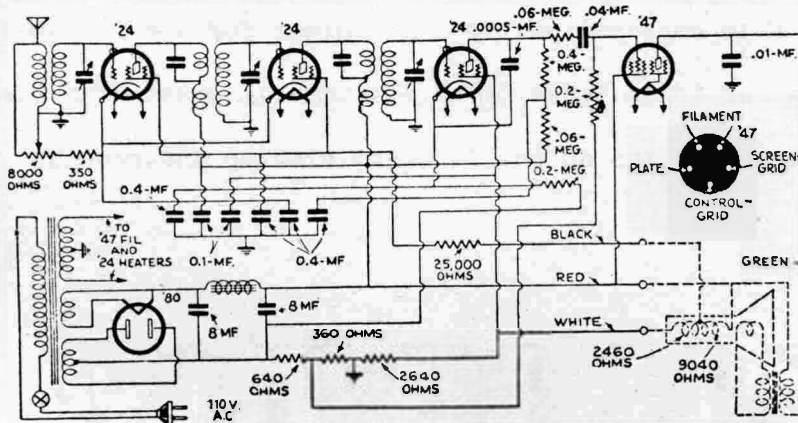

Fig. 10



U.S. Radio & Television Corp. Model 26P

Fig. 11

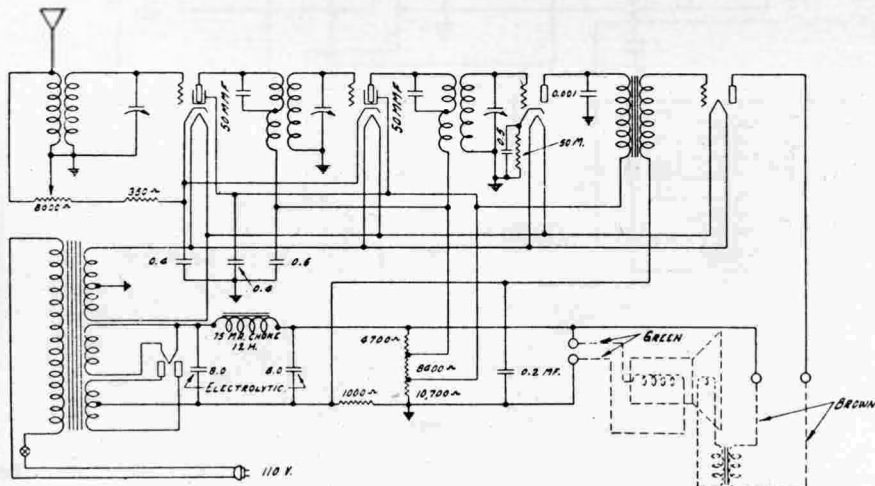

Fig. 12

The Steinite Model 427 illustrated in Fig. 13 follows customary circuit practice, except that a plate coupling choke is used in the detector stage to help in reducing the A.C. hum. Bias for the output pentode is obtained by employing part of the drop across the speaker field. The Music Master Petite illustrated in Fig. 14 also follows standard practice, except that in the output stage two type 47 pentodes are used connected in parallel. The speaker field has a resistance of 1000 ohms. Phono jacks are provided, but during normal radio operation these are shorted through a jumper. When a pick-up is to be used, the jumper is removed, and the pick-up is connected across the grid circuit of the tube in parallel with a 100,000-ohm resistor. Television jacks are provided, should an opportunity to use them ever come. A special $2\frac{1}{2}$ -volt secondary winding is also employed on the transformer for the filaments of the 47 pentodes, the bias for these tubes being obtained by means of a resistor connected between the center tap on the filament winding and ground.

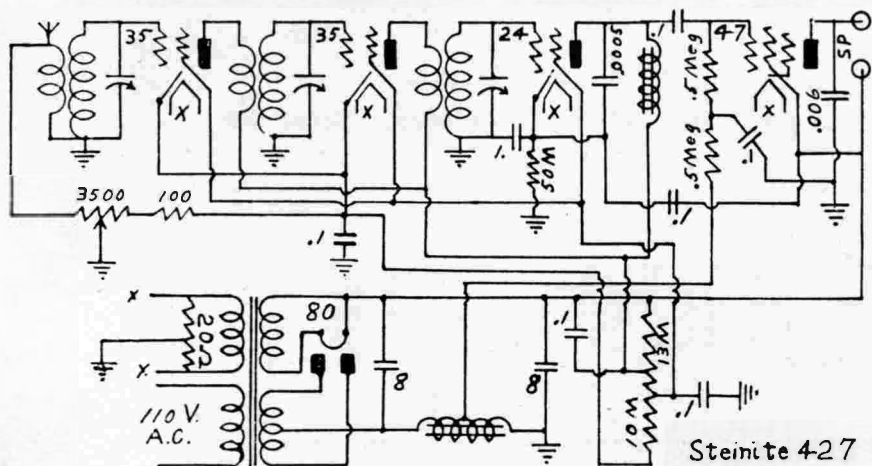

Fig. 13

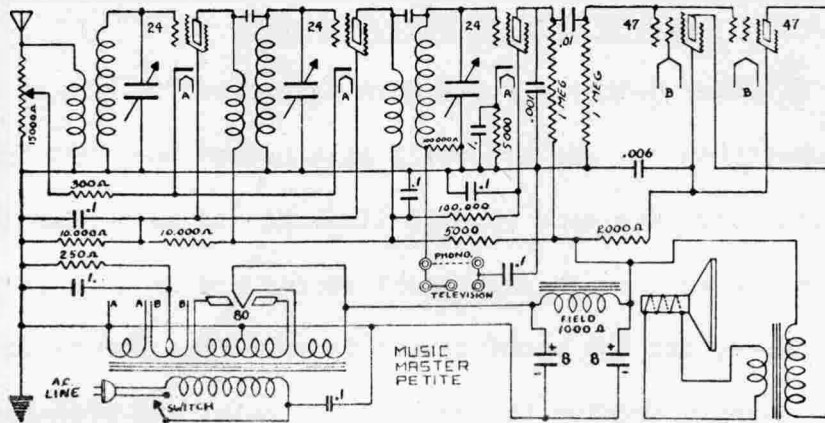
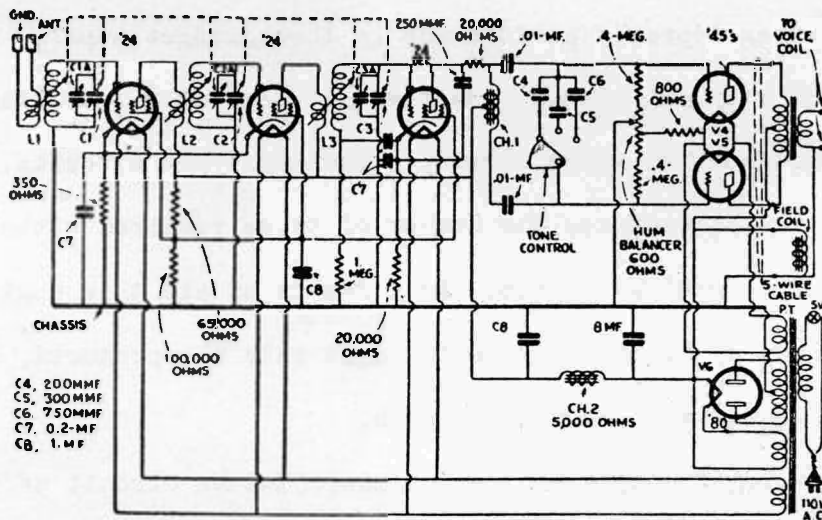

Fig. 14

The Colonial Model 36 midget illustrated in Fig. 15, presents a number of interesting features. It is a basic 5-tube circuit with a pair of 45's in push-pull in the output stage, a center-tapped choke being used to couple these tubes to the output of the 24 detector tube. The primary coils of the R.F. transformers shift around as the dial is rotated. This changes the degree of coupling between the primary and secondary coils at different frequencies, so that a uniform response is had over the entire range.



COLONIAL RADIO CORP. Model 36

Fig. 15

MIDGET SETS OF UNKNOWN MAKES

A large number of other 5-tube midgets were placed on the market by a host of large and small manufacturers and are still in abundant use, but they are all designed and built along the same general lines as the sets just described. Many of these sets were sold through department stores and mail order houses under private brand names, and the manufacturer is unknown. For these sets it is often difficult to obtain service information and data; and when such an occasion arises, all that can be done is to refer to some of the more or less standard hook-ups described and illustrated here, select the system that seems to fit the unknown receiver most closely, and apply the known circuit constants. In nearly every case they will work out properly.

SUPERHETERODYNE MIDGET RECEIVERS

After the introduction of the single-dial superheterodyne circuit, a new series of midget receivers appeared, for designs were quickly developed adapting the advantages of the superheterodyne to midget construction. Rapid progress was also made in obtaining improved performance in these midget supers, in the nature of better selectivity and higher sensitivity. New circuit combinations were devised and special purpose tubes developed for these new circuits. The chief aim, of course, was to decrease the number of tubes required without making any sacrifices in signal gain, etc. As a result of all this engineering development work, a group of highly efficient midget sets was produced, some of which vied in performance with many large sets.

Most of the early midget supers employed a basic 7-tube circuit of the following order: a preliminary radio frequency stage with a type 24 or 35 tube, a local oscillator with a type 27 tube, a 1st detector using a type 24 tube, an intermediate frequency stage with a type 24 or 35 tube, a 2nd detector (of the

speaker.

The Echophone Model 60 illustrated in Fig. 17 is also an early superheterodyne midget. The circuit is a straight superheterodyne system with the oscillator electro-magnetically coupled to the 1st detector, the latter being preceded by a preliminary R.F. stage. A type 47 pentode is used in the output stage. Models 80 and 90 are also much like the circuit illustrated in Fig. 17, but employ two type 47 pentodes in push-pull in the output stage. The tone control consists of a 20,000-ohm variable resistor in series with a .05-mfd. fixed condenser.

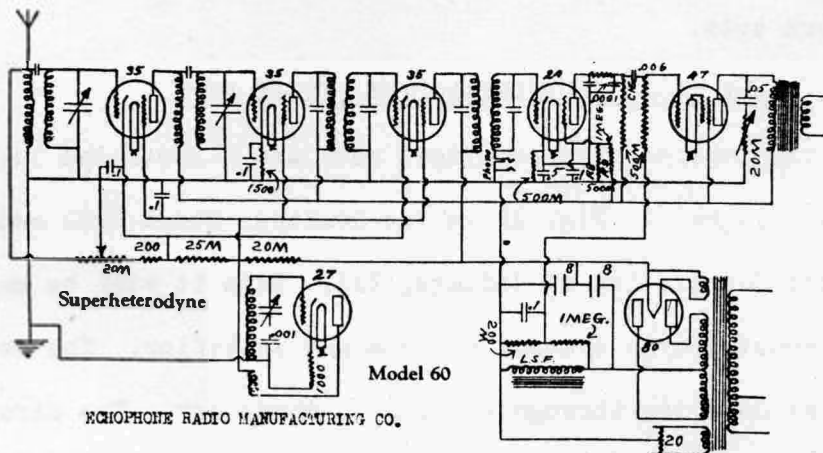

Fig. 17

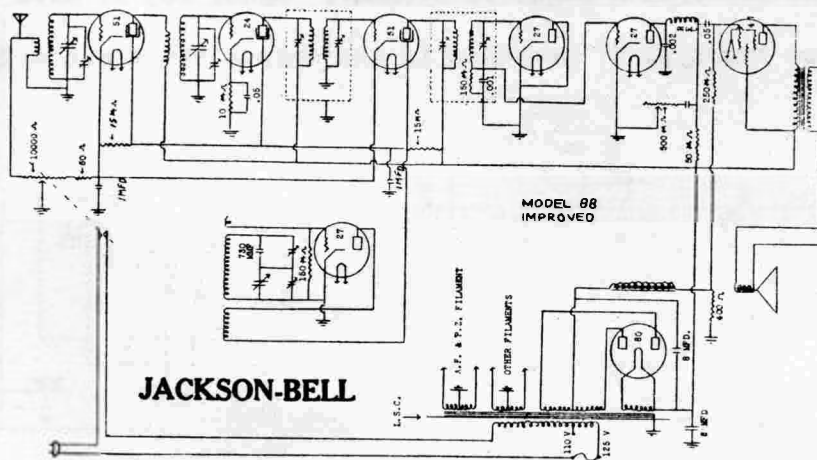

Fig. 18

SIMPLIFIED SUPERHETERODYNE CONSTRUCTION

Seven tubes were entirely too many and too cumbersome for midget set construction, and changes were soon sought to simplify work by reducing this number. The first step was to eliminate the preliminary radio frequency stage and merely precede the 1st detector by some form of doubly tuned pre-selector to produce reasonable selectivity. This reduced the number of tubes to 6.

The next step was to combine the 1st detector and oscillator into a composite stage and cause a single tube to serve the two-fold purpose of oscillator and mixer. This reduced the number of tubes to 5, which appears to be the practical limit, for with less tubes proper circuit operation is not to be had. The autodyne principle was the first to be adopted and was employed in the Clarion Model 320 receiver.

The circuit employed in the Clarion Model 320 is illustrated in Fig. 21, and it is the 1st detector-oscillator stage that is of interest here. A type 57 tube is used. In the plate circuit is the primary of the intermediate frequency transformer tuned to 175 kc., and also a feed back coil that is inductively coupled to the oscillator tank circuit, the latter always being tuned 175 kc. higher than the frequency of the incoming signal. This oscillator frequency is impressed on to the grid circuit of the tube through the lower section of the oscillator coil which at the same time serves as a cathode coupling coil.

Current flowing in the plate circuit of the tube induces oscillations in the tank circuit at the oscillator frequency. These oscillations are then picked up by the cathode coil, and in the grid circuit they combine with the incoming signal and form a beat frequency signal that is amplified in the tube and relayed on to the plate circuit. Two frequencies are thus operative

in the plate circuit, but the transformer primary is responsive only to the one frequency to which it is tuned, that is, the intermediate frequency for which the set was designed. In some circuits a separate coil is used for the cathode pick-up and in others the plate feedback coil is merely a section of the main tank coil, but the general operating principle in all is the same.

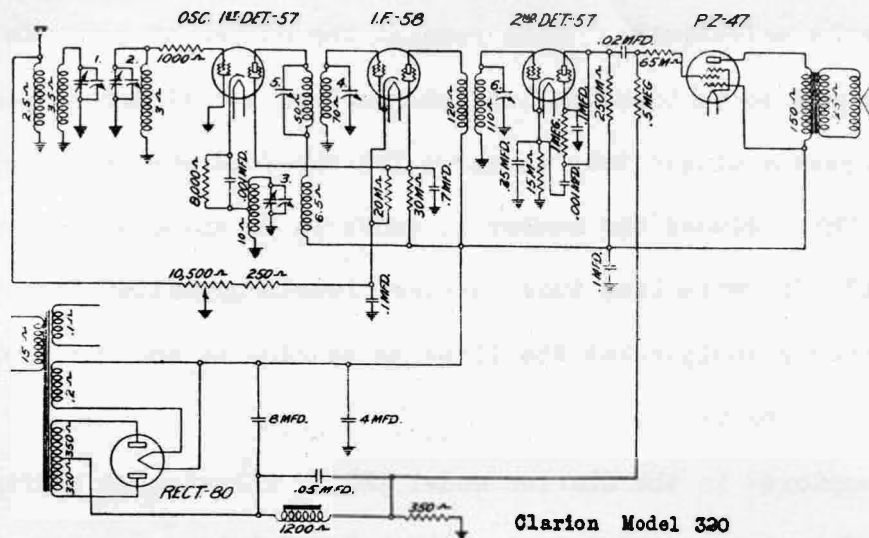
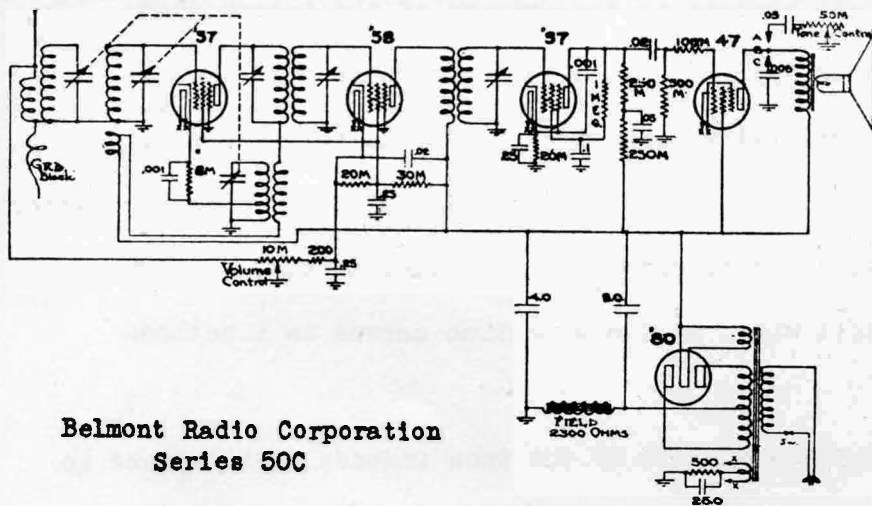

Fig. 21



Belmont Radio Corporation
Series 50C

Fig. 22

The Belmont Radio Corporation Model 50C is a similar 5-tube superheterodyne midget. The circuit arrangement is illustrated in Fig. 22. An independent or

floating tank coil is used, a section of which also forms the cathode pick-up coil. It receives its impulses from a feedback coil in the plate circuit. There is also a small tickler coil that reinforces the signals in the input grid circuit and thus introduces sufficient regeneration to improve the sensitivity of the set.

The Bosch Model 305-A receiver, as is illustrated in Fig. 23, also has a similar circuit arrangement. The operation of the composite 1st detector-oscillator stage is very much like that of the two circuits discussed previously. These three receivers are typical of this particular circuit arrangement; and although minor variations may be found in some sets that come to hand, the method of operation of each is alike.

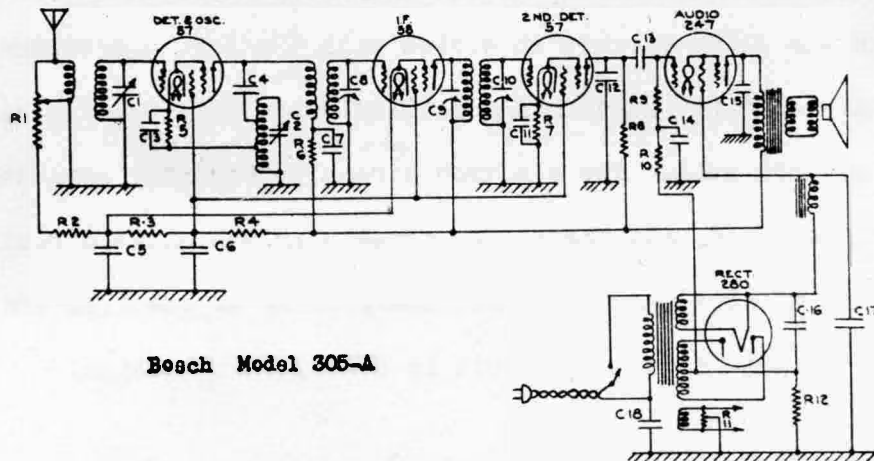

Fig. 23

FURTHER DETECTOR-OSCILLATOR DEVELOPMENTS

When the circuit possibilities were more fully realized of the type 57 and 58 R.F. pentode tubes with their three separate grid terminal connections, another detector oscillator system was developed that really proved quite satisfactory and was especially well adapted for midget superheterodyne receiver construction. In the new system the oscillator tank coil is connected into the

Lesson 44

suppressor grid line and inductively coupled to the plate circuit for feedback. The incoming signal as usual is impressed on the control grid. The electrons travelling from the cathode to the plate are thus twice or doubly modulated, and the signal reappears in the plate circuit at the required intermediate frequency. This system with the oscillator tank coil in the suppressor grid circuit was used in a large number of midget receivers, among them the Majestic Model 370 and the Fordson Model 6T.

The Majestic Model 370 is illustrated in Fig. 24. The entire circuit is quite standard in arrangement, except that the composite 1st detector-oscillator system is of interest here. The oscillator tank coil, it can be seen, is connected into the suppressor grid circuit and is tuned by one section of a 2-gang condenser. In the plate circuit in series with the I.F. transformer primary is the feedback coil for sustaining oscillations. The incoming signal is impressed on the control grid. The electron stream between the cathode and plate is thus doubly modulated, and the signal appears in the plate circuit at the desired intermediate frequency to which the primary of the I.F. transformer is tuned. The remainder of the circuit is of customary design.

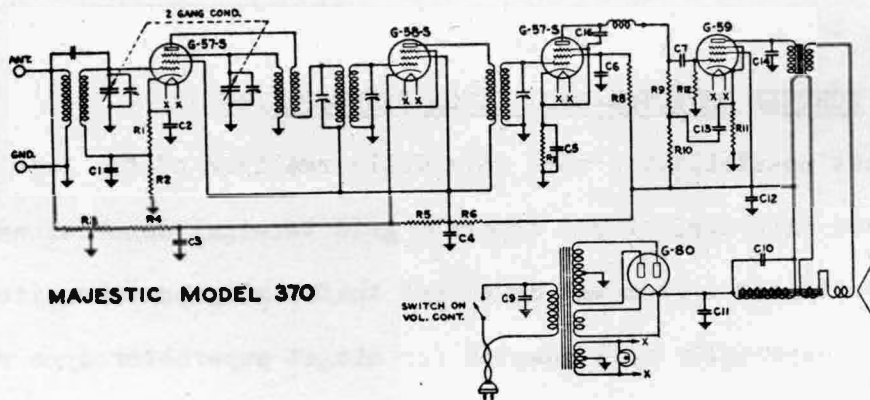

Fig. 24

The Fordson Model 6T illustrated in Fig. 25 uses a similar composite 1st detector-oscillator except that the tube is of the 58 type. The oscillator tank coil is in the suppressor grid circuit and is tuned by one section of a 2-gang condenser. The feedback coil for sustaining oscillations is in the plate circuit in series with the primary of the I.F. transformer. A type 58 tube is used as I.F. amplifier, and in the 2nd detector stage a type 55 double-diode triode, the triode section functioning as a 1st audio stage. Two type 59 tubes connected as pentodes are used in the output stage. The power supply is of standard design.

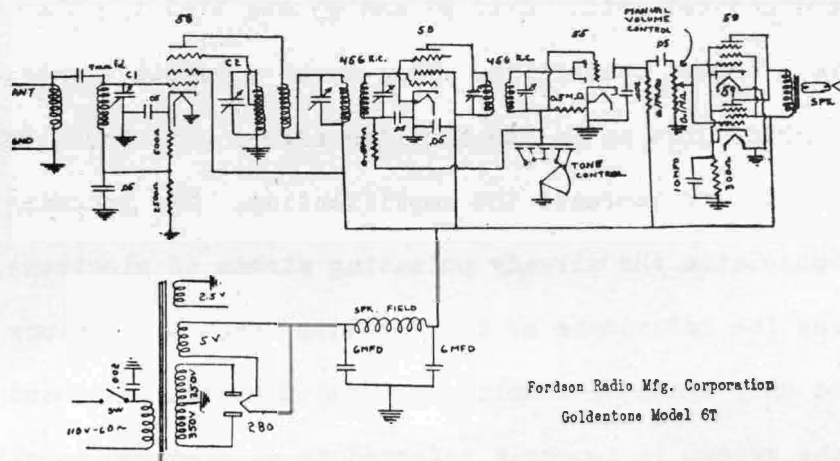

Fig. 25

THE PENTAGRID CONVERTER AS 1ST DETECTOR-OSCILLATOR

Although gradually improved performance was obtained with the composite 1st detector-oscillator systems described above and at the same time the number of tubes was reduced, still there was a further desire for more intensive modulation and greater conversion gain, that is, more signal amplification while the frequency is converted, and also the ability to control this conversion gain through variation of the grid bias of the tube.

The problem was solved through the development and introduction of the

pentagrid converter, a special 5-grid frequency converting tube carrying the trade numbers 2A7 and 6A7, and 1A6 and 1C6 for 2-volt battery operation. The elements within this tube can be divided into two groups. The first group operates as a triode oscillator and includes the cathode and the first two grids, called respectively the oscillator grid and anode grid. It acts like a virtual cathode that emits a pulsating stream of electrons, the pulsations occurring at the frequency to which the oscillator coil system is tuned.

The other section is the converter group and comprises the remaining three grids in conjunction with the plate and cathode. The incoming signal is impressed on grid #4, the control grid. Grid #3 and #5 are tied together internally and are brought out to a common connection. They carry a positive potential and serve as a screen grid, just as in the familiar screen grid tube, to reduce the internal tube capacity and increase the amplification. The incoming signal voltage thus further modulates the already pulsating stream of electrons, and in this manner produces the heterodyne or intermediate frequency. Since the electron stream is the only means of coupling between the oscillator and converter sections, the system is commonly referred to as electron coupling.

The advantages of this new composite tube are four in number: the tube forms a stable oscillator system, effective signal modulation is obtained, it yields a high amplification gain during the conversion process, and lastly it permits control of this gain through variation of the grid bias on the tube. With the use of this tube an effective 5-tube midget can be designed, either of the straight A.C. operated type or of the universal A.C.-D.C. type. Practically all modern midget sets of the better grade employ this tube and generally have the following circuit arrangement: a type 2A7 or 6A7 tube as 1st detector-oscillator, a type 58, 78 or 6D6 as I.F. amplifier, a duo diode of the 85 or 75

type as 2nd detector and 1st audio, and a type 42 or 43 pentode in the output stage. In the A.C. operated receivers a type 80 rectifier is commonly used and in the A.C.-D.C. receivers either a type 12Z3 or 25Z5 rectifier.

Modifications of these arrangements will be found in some midgets, for example: a type 6F7 tube is sometimes used as a composite or dual purpose tube in the I.F. and 1st or 2nd detector stages, a type 76 or 2B7 tube is used as 2nd detector, and a type 59 in the output stage. However, unless the circuit arrangement of a receiver of unknown make is radically different from those shown in the following illustrations, the circuit constants given can generally be applied to good advantage. Of course, common sense and good judgment must be exercised in every case, but in similar circuit set-ups similar values of resistors and condensers are generally always applicable. The function or use of a condenser and its location in the circuit determine, respectively, its size and voltage rating. Similarly with a resistor, its duty and the nature of the circuit into which it is connected determine its resistance value and wattage rating.

THE UNIVERSAL A.C.-D.C. MIDGETS

The universal A.C.-D.C. midgets comprise a large group of electrically operated receivers, the distinguishing feature of which is that they can be operated from both alternating current and direct current 110-volt electric power lines. This universal A.C.-D.C. operation is made possible through the use of a half-wave rectifier tube connected into one side of the power line. On alternating current lines this rectifier furnishes direct current power to the plate and screen circuits of the operating tubes in the radio receiver, while on direct current operation the tube merely floats on the line like a low value series resistor. During D.C. operation the receiver must be connected

to the line so that the positive side leads to the plate of the rectifier tube.

The filaments of the tubes in these A.C.-D.C. midgets are connected in series together with a resistor of suitable value to reduce the line voltage to the value needed by the group of tubes thus connected in series. In the earlier universal midget sets this series filament resistor was mounted on the chassis with the rest of the component units, but in the later sets it was built into the wire cord that connects the receiver to the electric light outlet. Here the heat is more easily dissipated and also the set cabinet does not become so hot.

Both tuned radio frequency and superheterodyne circuits are used in these A.C.-D.C. midgets. The earlier sets used four tubes, a tuned radio frequency stage, detector and audio output stage, and a half-wave rectifier. Later on the number of tubes was increased to five by adding another R.F. stage. When the single-dial superheterodyne system was made available it was quickly adapted for use in these universal midgets; and as the newer R.F. pentodes and dual purpose double diode detector tubes as well as the pentagrid converter tube came into use, these also were readily adopted for use in the A.C.- D.C. sets. As a result of these various circuit developments and tube adaptations, the A.C.-D.C. midget has been engineered to a very high degree of sensitivity and selectivity. The modern universal midget receiver, in its most common form, employs a 5-tube superheterodyne circuit of the following order: a composite 1st detector-oscillator, an intermediate frequency amplifier stage, a 2nd detector, an audio output stage, and a half-wave rectifier. The various circuits may differ somewhat in the type of tubes used in each stage and the volume control systems used, etc., but the general circuit arrangement is as described.

HUM PROBLEMS IN A.C.-D.C. RECEIVERS

Hum in universal A.C.-D.C. receivers is generally one of two kinds: one which is present when no signal is being received, and that which appears with an impressed signal. The principal sources of hum when no signal is being received are:

1. Unbalanced in power supply to set
2. Insufficient filtering
3. Heater to cathode leakage
4. Inadequate bypassing of cathode resistors
5. Incorrect cathode resistor in detector-oscillator system
6. Coupling from oscillator to input of 2nd detector

The two chief causes of hum appearing with a tuned in signal are:

1. Reradiation from the rectifier
2. Overloading input stage with strong signal

Hum caused by unbalance of the power line may be checked by reversing the line plug. If any difference in hum is noted, this indicates an unbalanced condition. This can usually be cured by employing a dual condenser, of about 0.1 mfd. for each section, between each side of the line and the chassis.

Insufficient filtering is one of the most frequent sources of hum because of the limited space which can be used for filters. If a 12Z3 rectifier is employed the value of inductance or capacities should be increased if possible. If a 25Z5 is used as a half-wave rectifier with both cathodes in parallel, some improvement may be noted by separating the field of the speaker from the rest of the filter system. Under this condition one cathode supplies speaker excitation while the other supplies plate voltage for the tubes in the circuit. An advantage of this system is that the excitation and plate voltage may be

adjusted independently by changing values of filter condensers.

Reduction in hum may also be effected by making certain that the tubes most subject to hum have their heaters connected into the voltage supply in such a way as to be nearest the negative plate-supply terminal. Usually it will be found that the best arrangement is the following, starting from the negative plate-supply lead: 2nd detector, detector oscillator, output tube, to be followed by the remaining tubes. The series resistor usually should be connected to the side of the line feeding the rectifier plate or plates, followed by the rectifier heater.

Bypassing the cathode resistors of both the second detector and output tube with large capacity low voltage electrolytic condensers will aid in reducing the hum.

Many detector oscillator circuits operate the detector-oscillator tube with a relatively low bias resistor in the cathode circuit (5000-ohms or less). This condition often leads to bad hum conditions since the peak oscillator voltage on the grid of this tube is considerably higher than the grid bias, causing grid current to flow during part of each cycle. Besides introducing hum this gives rise to poor selectivity and gain. It may be necessary to readjust the coupling in order to employ a resistance of the proper value (10,000-ohms).

Usually hum which is present only on tuning in a signal is called "modulation hum". If the incoming power line has not been filtered the signal may be fed into the rectifier tube, where it is modulated with the rectified hum voltage and then reradiated or carried to the antenna or input system of the receiver. A filter as mentioned above will correct this condition.

When large signals are applied to the receiver the grid of the input tube may be driven positive during part of the grid cycle. The remedy for hum

arising from this source is to insert sufficient attenuation between the input system and the input of the first tube.

SERVICE PROBLEMS IN MIDGET SETS

Midget sets, of course, are subject to the same general ills that the larger types of radio receivers are; but on account of the compact construction in midget sets and the rigid economy observed by some manufacturers to reduce the price to a minimum, certain mishaps are more common than others. Accordingly, if service inspection in a defective midget is directed first to those placed where experience has shown trouble most frequently occurs, much valuable time and effort can be saved.

When a midget set is brought in for repairs and a test of the tubes reveals that the trouble does not lie there, the chassis should be removed from the cabinet and a thorough surface inspection made. This includes the following: clean the tuning condenser and make sure that the plates do not scrape in any position, see that all shielding cans and grid caps are rigid and tight and that all tubes are snug in their sockets, also that the volume control and tone control if one is used are fastened tight to the chassis, that the antenna chord is not broken, that all set-screws and rivets are drawn tight, and that there are no loose elements of any kind.

If such a surface inspection of the chassis reveals everything correct, a further examination of the inner circuit components must be made. First check every soldered joint to see that good electrical contact exists at each and that there are no high resistance, cold or rosin joints. Then check all the bypass condensers beginning with the detector-to-audio coupling condenser which generally breaks down first. Continue with the screen grid to ground bypass condenser and then the grid to cathode return condenser, and lastly all cathode

resistor bypass condensers. Wherever the least doubt exists about the condition of a condenser, replace it with a new one, for the low cost of a condenser does not warrant spending an extra hour or two checking the rest of the circuit when the analysis will only lead back to the original suspicious unit. Lastly check the filter condensers for puncture or short circuit.

After the condensers have all been checked or replaced and the set still fails to function, the resistors should be tested. The screen grid series resistor seems to be most likely to cause trouble and should be checked first. Then proceed with the other resistors. It is best to make these resistor and condenser tests after the set has been in operation for twenty minutes or so in order that all units have had ample time to heat up, for oftentimes a condenser or resistor will test good when cold but will change its value or open up entirely when heated to a working temperature. Generally such a condenser and resistor check-up will disclose the seat of the trouble. However, if the trouble does lie elsewhere, then a further inspection must be made of the other component units such as the coils, trimmer condensers, series filament resistor, etc.