

**LESSON
4 R**

RADIO CIRCUITS



RADIO-TELEVISION TRAINING SCHOOL, INC.

5100 SOUTH VERMONT AVENUE • LOS ANGELES 37, CALIFORNIA, U. S. A.

RADIO CIRCUITS

Imagine that you are trying to force your way through a room full of closely-spaced immovable posts, with many other people milling about between the posts and always trying to push you away from themselves. Supposing, too, that the posts were fitted with hooks that would catch and hold you if you came too close. Certainly you would use up a great deal of energy in making progress in any one direction.

This illustrates some of the difficulty that besets free negative electrons when they flow in conductors. The immovable posts are the stationary atoms and molecules. The hooks are the attractive forces of atoms which temporarily are positive because of having lost an electron. And the other people are the other free negative electrons in the same conductor.

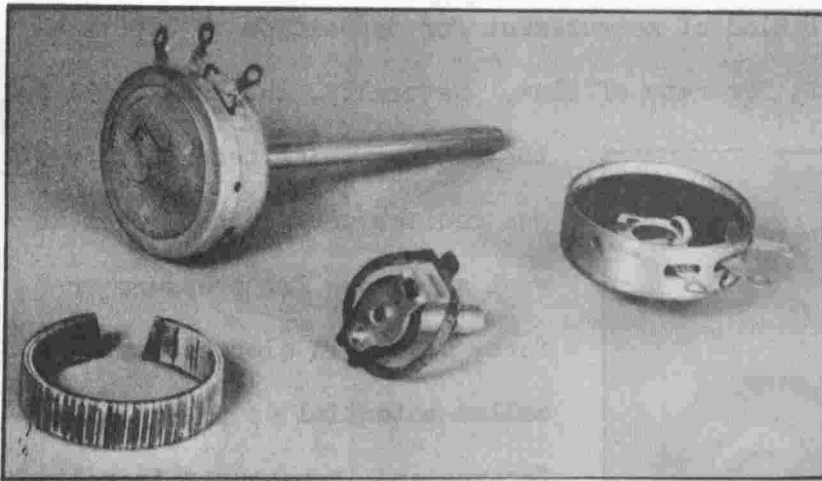

FIG. 1.

An adjustable resistor of the wire-wound type, used for volume control. The complete unit is at the top; the parts are below.

small, but it always is there in some degree.

In iron, nickel, and in many mixtures or alloys of these and other metals the hooks are long and sharp. Free electrons are frequently caught, and they find it hard to break loose again. These materials have high resistance. But in copper, aluminum, silver, and some other metals the free electrons are not held very securely and progress is relatively easy. Here we have low resistance.

The opposition which we call resistance may be measured in a unit which is just as precise as the volt in which we measure potential, and as the ampere in which

You might call the opposition to your progress by various names, but for the opposition to progress of free electrons in a conductor we have one particular name. That name is electrical resistance. In all conductors there is resistance; sometimes great and sometimes

we measure flow rate. Before we name this unit of resistance, let's figure out a way in which resistance might be measured.

Consider the flow of water through a pipe. If the pipe is new and clean, it offers little opposition to flow of water, but if the pipe is full of scale and dirt, it offers relatively great opposition. In what kind of unit might we measure the resistance or the opposition to flow of water through the pipe? The unit doubtless would be based on some certain rate of flow -- say on a rate of one gallon per second. And we would need a measure of the force or pressure required to maintain the selected flow rate. This force might be measured in pounds per square inch of pressure. Then we could say, for example, that the pipe resistance is such as to require a pressure of ten pounds per square inch to maintain a flow rate of two gallons per minute.

To arrive at the same general kind of measurement for opposition to electron flow, we first must select a unit for rate of flow. Naturally, this unit will be

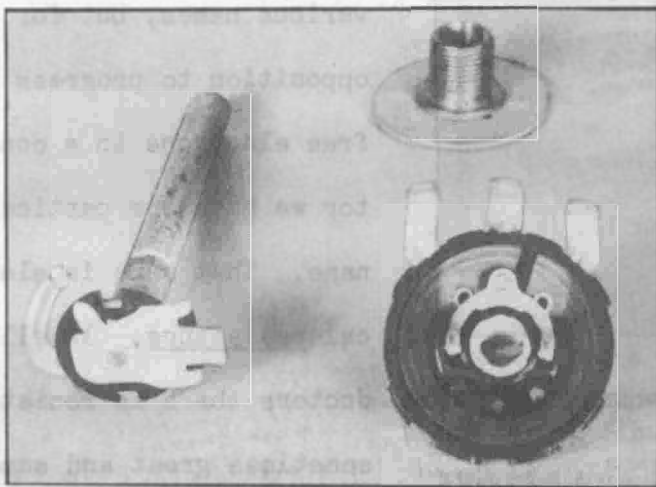

the ampere, which means a flow of one coulomb per second. Then we want a measure for pressure or force which, in electricity, is called potential or potential difference and is measured in volts. Combining the idea of rate of flow with the idea of the force which

FIG. 2.

An adjustable volume control resistor having a resistance element of carbon or graphite.

has to be applied to maintain the rate, our unit of resistance will be "volts per ampere".

Say that we find it takes a potential difference of 10 volts to maintain a flow rate of 2 amperes in a certain conductor. If it takes 10 volts to maintain a flow of 2 amperes, it will take 5 volts to maintain a flow of one ampere, because half the force will maintain half the original flow rate. We may specify the resistance

of this conductor as "five volts per ampere".

The practical unit of electrical resistance actually is volts per ampere, but instead of using this rather long term, we have one short word that means the same as volts per ampere; that one word is ohm. The conductor just considered has a resistance of 5 ohms, which is the same as 5 volts per ampere, and which means that for every ampere (coulomb per second) of flow rate the potential difference between the ends of this conductor must be 5 volts.

THE LANGUAGE OF RADIO

In the radio business, as in all of the electrical business before it, the practice always has been to use very special kinds of words which have no counterparts in other fields or sciences. So far we have come across at least four such words: coulomb, volt, ampere, and ohm. The coulomb measures quantities of electrons. The volt measures forces which move electrons. The ampere measures rate of electron flow. And the ohm measures electrical resistance.

It is special words like these which help to make radio, and electricity, rather difficult to study. You not only have to learn new facts, but at the same time have to learn a new language. Just as with any other new language, it takes quite a while before its words convey very definite ideas to your mind. It is one thing to be able to give a definition of a volt or some other unit, but quite something else to have a real understanding of what a volt of potential difference will accomplish in a practical way. The only way to make the words volts, amperes, ohms, and all the others seem related to things which are real is to use these words constantly.

Maybe you wonder where the special words come from in the first place. Well, the coulomb is named to honor a French physicist, Charles de Coulomb. The volt is named for an Italian physicist, Count Volta. The ampere is named for a French scientist, Andre Marie Ampere. And the ohm is named for a German investigator, Georg Simon Ohm. Later we shall come to still other radio and electrical units named for other workers who have done much for the advancement of these sciences.

Among the familiar sources of electrical energy are dry cells such as used in flash lamps and many other electrical devices. A single dry cell, no matter what its size, will develop an internal electromotive force of almost exactly $1\frac{1}{2}$ volts, consequently will provide at its terminals a maximum potential difference of very nearly $1\frac{1}{2}$ volts. Another type of cell is found in the storage batteries of automobiles. While these storage cells are causing electron flow (current), as for lighting the lamps, each cell provides a potential difference of about 2 volts, regardless of how large or small the cell may be. Most car batteries have three cells working together, and the three provide a total potential difference of about 6 volts.

Any given type of battery cell provides a certain potential difference. A big cell of given type will cause flow of a certain current for a longer time, and a small one of the same type will cause flow of the same current rate for only a relatively short time, but both provide the same potential difference or voltage. The potential difference, or internal emf, depends only on the materials of which the cell is made and on how the materials are arranged within the cell.

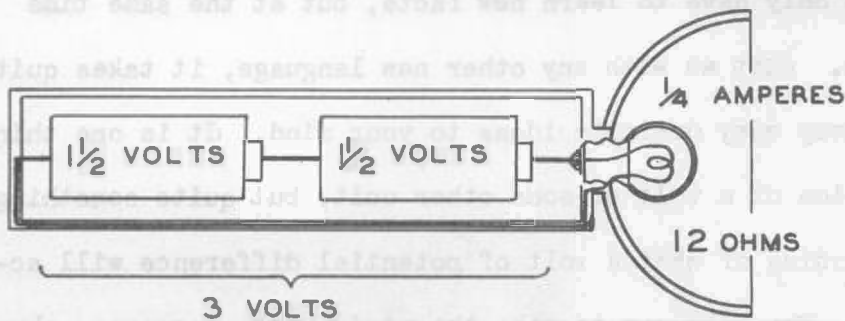

FIG. 3.

Connections of dry cells and bulb in a flash lamp.

Doubtless you know that in many flash lamps the lamp case holds two dry cells, as in Fig. 3. Each cell provides a potential difference of $1\frac{1}{2}$ volts, and the two working end to end provide

a total potential difference of 3 volts. To light the little bulb to normal brilliancy requires an electron flow rate of $1/4$ ampere. That is, for electrons to do enough work in the filament to make it white hot, the flow rate has to be $1/4$ ampere.

We may work out the "volts per ampere" resistance method in the case of the flash lamp. This is the way in which we make the computation: it takes 3 volts to main-

tain a flow rate of $1/4$ ampere. Then how many volts would it take to maintain a flow of 1 ampere, which is four times the $1/4$ -ampere rate? It would require four

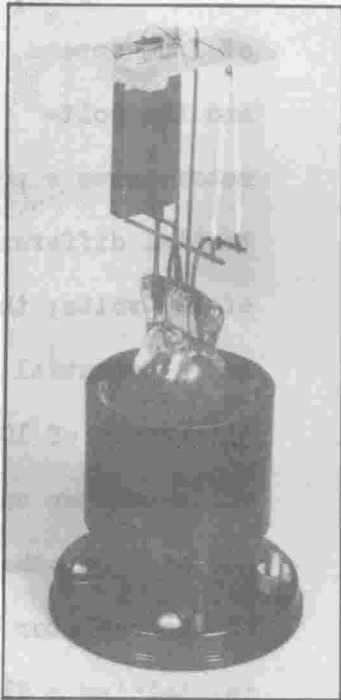

FIG.4.

In this two-section tube one of the plates has been removed to expose the filament cathode.

times the potential difference of 3 volts, or would take 12 volts to maintain a flow of 1 ampere. Then the resistance of the filament is 12 volts per ampere, and since volts per ampere is the same as ohms, the resistance is 12 ohms.

The opened-up radio tube of Fig. 4 has been exposed by removing the plate which normally encloses the filament. To produce the temperature necessary for electron emission, the electron flow in these filaments must be maintained at 2 amperes. This rate of flow will be maintained when the potential difference applied to the filaments is 5 volts. Then what about volts per ampere? It requires a potential difference of 5 volts for a flow rate of 2 amperes. For a flow of 1 ampere, half as much, it would require half as much potential difference, or $2\frac{1}{2}$ volts. Then

the resistance is $2\frac{1}{2}$ volts per ampere or is $2\frac{1}{2}$ ohms in the filaments.

In Fig. 5 is shown a fixed resistor such as sometimes used in plate circuits and screen grid circuits. Assume that we don't know the resistance, in ohms, of this resistor, but should like to determine it. We may measure the resistance by placing the re-

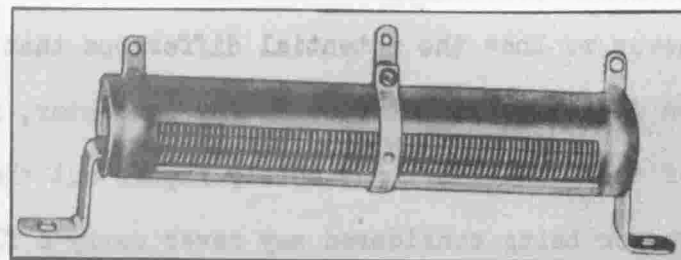

FIG.5.

A resistor with an adjustable contact which may be moved along the exposed wire winding, then tightened in place.

sistor in the circuit shown by Fig. 6. There is a source of potential difference to cause electron flow. Between one side of the source and one end of the resistor

is connected a meter which measures flow rates in amperes or in fractions of an ampere. Such a meter is called an ammeter. To the two ends of the resistor is connected another meter which will measure potential differences in volts. This meter is called a voltmeter.

Now we read the indications of the two meters. The ammeter shows a flow rate

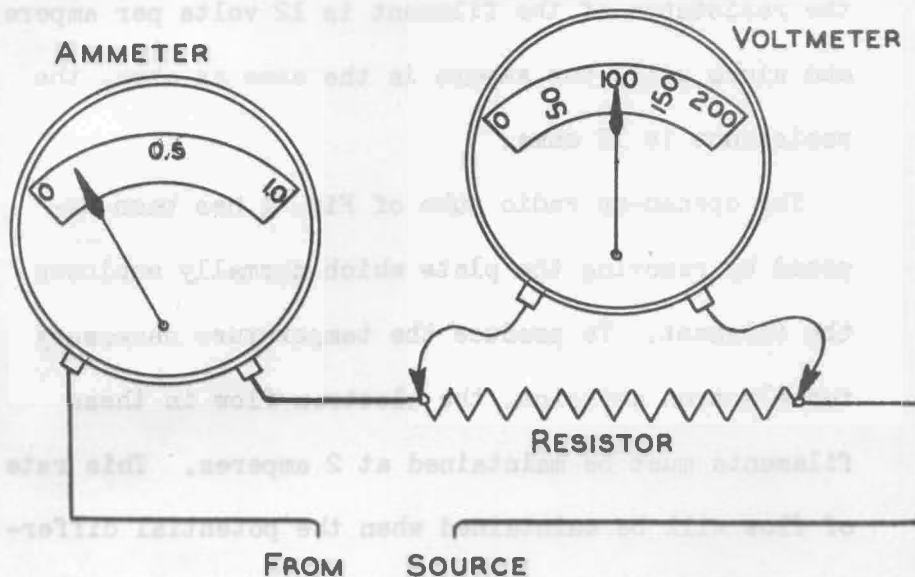

FIG. 6.

Measuring the current and the potential drop in a resistor.

in the resistor. Now, if 100 volts cause a flow of $1/10$ ampere, it will require 1,000 volts for a flow of 1 ampere; with ten times the potential difference, we would get ten times the flow rate. Then the resistance of this resistor is 1,000 volts per ampere, or is 1,000 ohms.

Whenever we know the potential difference that will maintain any certain rate of electron flow in a resistor or in any conductor, it is easy to determine the resistance of that conductor. We merely figure out the volts per ampere. The resistor or conductor being considered may never carry a flow rate of a whole ampere, or it might carry a flow of many amperes. A flow rate of a whole ampere in the resistor of Fig. 5 would make the resistance wire so hot that it would melt. All we need determine is the number of volts which would cause a flow of one ampere were such a flow practicable.

of $1/10$ ampere, and the voltmeter shows a potential difference of 100 volts; that is, a potential difference of 100 volts between one end and the other of the resistor is maintaining a flow rate of $1/10$ ampere

In the preceding examples of computing resistances we have used nothing more than common sense; we have reasoned out the answers. Instead of that, we may use very elementary arithmetic to get the same answers more quickly. Here is the method: To determine a resistance in ohms when you know the potential difference in volts and the flow rate in amperes, divide the number of volts by the number of amperes. The result of this division is the number of ohms of resistance.

Let's try this method on the problems already solved. For the flash lamp the potential difference is 3 volts and the current (electron flow rate) is $1/4$ ampere. The number $1/4$ goes into the number 3 just 12 times, so the lamp resistance is 12 ohms.

For the radio tube filaments the potential difference is 5 volts for a flow rate of 2 amperes. Dividing 5 (volts) by 2 (amperes) gives $2\frac{1}{2}$ as the number of ohms of resistance in the filaments.

With the resistor we found that a potential difference of 100 volts would cause a flow of $1/10$ ampere. The number $1/10$ goes into the number 100 just 1,000 times, which shows that the resistance of the resistor is 1,000 ohms.

If you feel that dividing fractional numbers isn't so easy, you will be glad to know that you can be a first class radio technician without having to make such computations unless you wish to make them. But while we are studying the principles of radio, many facts of importance may be brought out by such computations, which is our chief reason for using them. By the time we do some figuring with actual values or actual numbers of volts, amperes and ohms, you will have firmly fixed in your mind how the value of volts, or amperes, or of ohms will have to vary when changes are made in one or more of these factors-- and that is the important thing.

You may memorize, if you like, the rule that dividing volts of potential difference by amperes of flow rate always will give ohms of resistance. But this rule will come in handy so many times, and you will see it operate so often, that eventually you won't be able to forget it.

THE IMPORTANCE OF RESISTANCE

Here is something we should think about. Except for the evacuated spaces in tubes, every part of every kind of radio apparatus in which there is electron flow is a conductor. Now let's ask, what is the chief electrical property of a conductor? A conductor, separated from everything else, has no potential or potential difference; it is of the same potential all over. Neither has that conductor any electron flow; the free electrons just move at random within the conductor. But every conductor always has resistance. It will repay us well to spend some time getting acquainted with resistance, with the things which make it greater or less, and with just how resistance affects electron flow under various operating conditions.

To begin with, the resistance of a conductor depends on the kind of material in the conductor. This is because some materials have more free electrons than others, and because the electrons are held more tightly in the atoms of some materials than in others. The accompanying table lists the number of ohms of resistance per 100 feet in the size of wire called number 20 gage when the wires are made of various conductor materials. We select number 20 wire because this size is so often used in radio apparatus.

RESISTANCES OF CONDUCTOR WIRES
Ohms per 100 feet of No. 20 gage wires.

Silver	0.95	Iron	5.86
Copper	1.02	Steel	6.54
Aluminum	1.66	Manganin	26.4
Tungsten	3.24	Constantan	28.7
Brass	4.78	Nichrome	64.7
Nickel	5.08	Carbon	2050.0

Silver has less resistance than any other metal, but copper has almost as little and is so much less costly that copper is the most widely used of all conductors. Manganin, Constantan and Nichrome are examples of the mixtures or alloy metals used in resistors, where we desire to have a considerable resistance in small space. Carbon is included in the list, not because we use wires of carbon, but

to show the reason for using carbon and its modified form called graphite where great resistance is needed in a very limited space. The resistance element of the adjustable resistor in Fig. 2 is made from carbon, as are many of the fixed resistors used in radio.

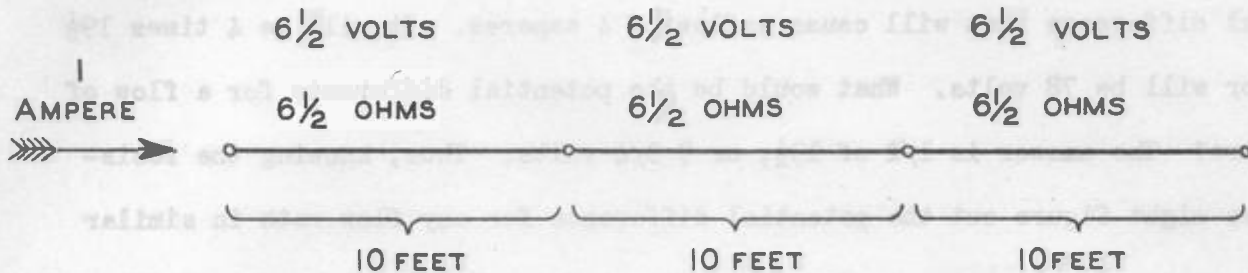

FIG. 7.

In resistors connected end to end the resistances and the potential drops add together.

Another factor which affects the resistance of a conductor is the length of the conductor. If electrons have a certain amount of difficulty in getting through 100 feet of a certain kind and diameter of wire, they will have twice as much difficulty in getting through 200 feet, and only half as much in getting through 50 feet. Usually we say that resistance is directly proportional to the length of a conductor when the conductor is alike during the whole length. When you know the resistance per foot of such a conductor, it is necessary only to multiply that number of ohms (per foot) by the number of feet of total length to arrive at the total resistance in ohms.

Let's pause here for a few moments to see what might be done with the facts which we are learning. Look at Fig. 7, which represents in the form of a diagram three 10-foot lengths of the kind of Nichrome wire whose resistance is given in the table. The lengths are connected together end to end. The table gives the resistance as 64.7 ohms per 100 feet, which would come to 1/10 of this or to 6.47 ohms per 10 feet. This is so close to 6.50 or $6\frac{1}{2}$ ohms that we shall use the value $6\frac{1}{2}$. Of course, we know immediately that the total resistance is 3 times $6\frac{1}{2}$, or is $19\frac{1}{2}$ ohms.

The number of ohms means the number of volts potential difference used per ampere

of flow. Then $6\frac{1}{2}$ ohms of resistance in each 10-foot length of wire means that, with a flow of 1 ampere, the potential difference across each length would be $6\frac{1}{2}$ volts. If we are using $6\frac{1}{2}$ volts of potential, or energy, in each length, how much are we using in all three lengths? Of course, the answer is 3 times $6\frac{1}{2}$ volts, or $19\frac{1}{2}$ volts for the flow rate of 1 ampere. Supposing we wish to determine the potential difference that will cause a flow of 4 amperes. It will be 4 times $19\frac{1}{2}$ volts, or will be 78 volts. What would be the potential difference for a flow of $\frac{1}{2}$ ampere? The answer is $\frac{1}{2}$ of $19\frac{1}{2}$, or $9\frac{3}{4}$ volts. Thus, knowing the resistance, we might figure out the potential difference for any flow rate in similar fashion.

The example of the three lengths of Nichrome wire has been used merely to show what can be done with our present information. The same problems can be solved by a method ever so much easier than the one we have used, a method which will be shown as soon as we finish talking about things which affect resistance of a conductor.

Still another factor which affects the resistance of a conductor is its width and thickness, or its diameter if the conductor is round. We really mean that the factor is the cross sectional area. The cross sectional area is the area, usually in fractions of a square inch, of the end of the conductor when the conductor is cut straight through from side to side. The reasons follow.

Look at diagram A in Fig. 8. Here is represented a conductor in which the flow rate is 2 amperes when the potential difference is 12 volts. What is the resistance of the conductor? It is 12 volts per 2 amperes, or 6 volts per ampere, or 6 ohms.

In diagram B we have two conductors, each exactly like the conductor at A, and both subjected to a potential difference of 12 volts. Each conductor will carry 2 amperes of current or electron flow because, as we determined for diagram A, the resistance of each conductor is 6 ohms. Supposing that you squeeze these two conductors tightly together along their entire lengths, finally forcing them into a

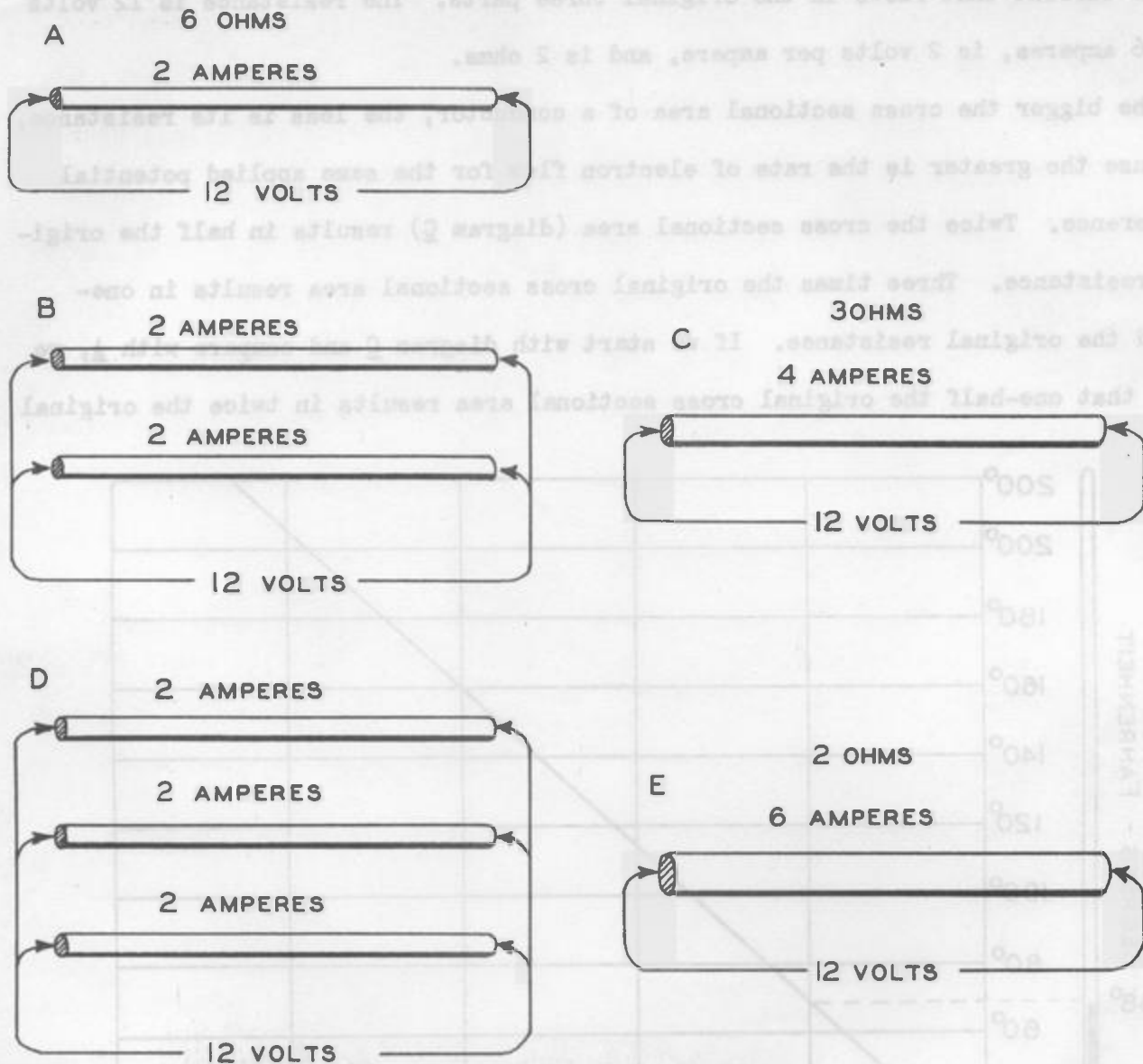

FIG. 8.
Increasing the cross sectional area of a resistor lessens its resistance.

single conductor of twice the cross sectional area of one conductor, as in diagram C. This new and bigger conductor carries the total flow of 4 amperes that exists in the two original parts. What is the resistance? It is 12 volts per 4 amperes, is 3 volts per ampere, and is 3 ohms.

In diagram D there are three conductors, all like the one at A, each subjected to the same 12-volt potential difference, and each carrying 2 amperes of current. In diagram E the three conductors have been formed into one, of three times the

original cross sectional area. This big conductor must be carrying the 6-ampere total current that flows in the original three parts. The resistance is 12 volts per 6 amperes, is 2 volts per ampere, and is 2 ohms.

The bigger the cross sectional area of a conductor, the less is its resistance, because the greater is the rate of electron flow for the same applied potential difference. Twice the cross sectional area (diagram C) results in half the original resistance. Three times the original cross sectional area results in one-third the original resistance. If we start with diagram C and compare with A, we find that one-half the original cross sectional area results in twice the original

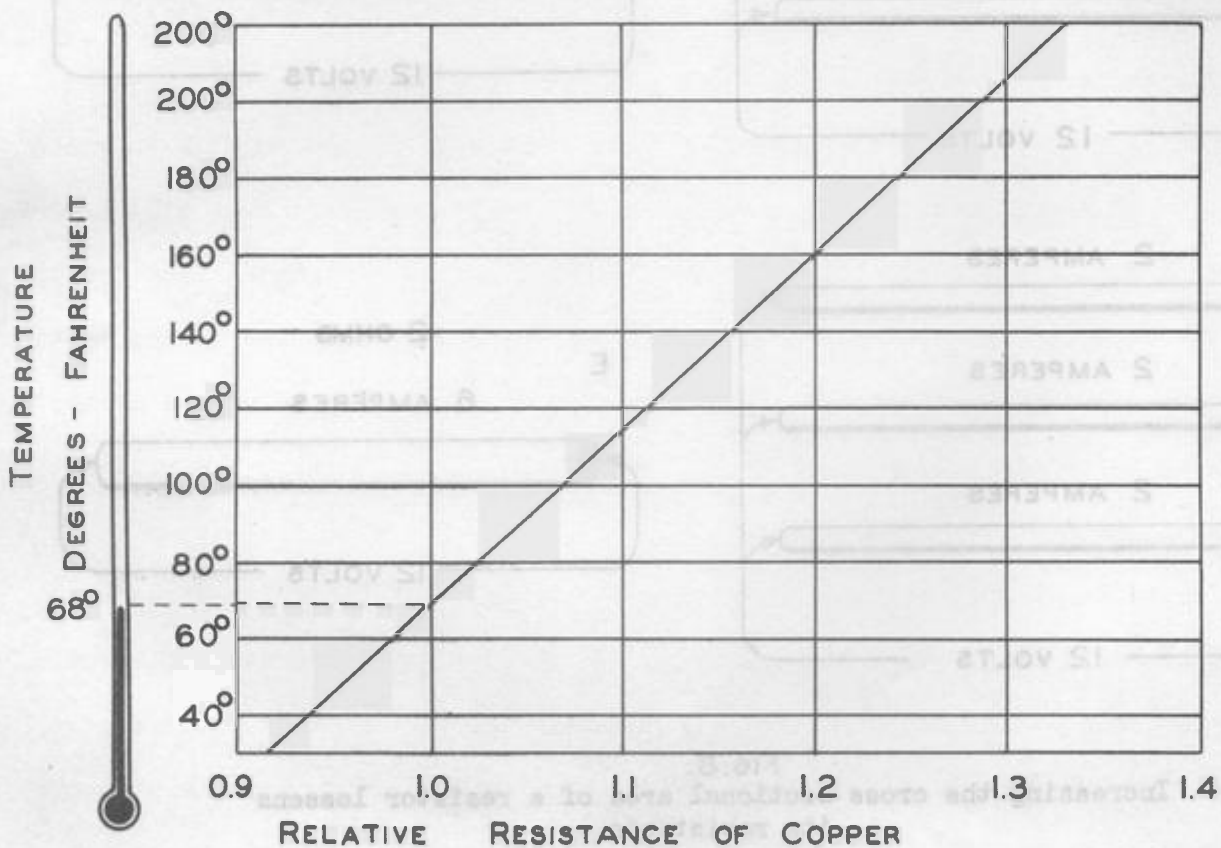

FIG.9.

How resistance of copper changes with variation of temperature.

resistance. In any case, the bigger the conductor, the less the resistance, and the smaller the conductor, the greater is the resistance. If we want to use mathematical language, we say that the resistance is inversely proportional to the cross sectional area.

So far we have found that resistance is affected by kind of conductor material, by length, and by cross sectional area. There is one other thing which affects resistance. It is temperature. In all pure metals, and in most alloys or mixtures of metals, the higher their temperature, the greater their resistance, and the lower their temperature, the less is their resistance.

Fig. 9 is a chart showing how the resistance of copper wire varies with change of temperature. When resistances are specified without any mention of temperature, it always is assumed that the temperature is 68 degrees Fahrenheit, which is the same as 20 degrees Centigrade. Therefore, in our chart we show the resistance as 1.0 at 68 degrees for a starting point or reference point.

Supposing that you have a transformer, the resistance of one winding in which is 15 ohms at the standard reference temperature of 68 degrees. What will be the resistance at 160 degrees? Following to the right on the horizontal line for 160 degrees of the chart, we find that this line cuts the diagonal line on the vertical line corresponding to a relative resistance of 1.2. Then the resistance of the winding at a temperature of 160 degrees will be 1.2 times 15 ohms, and will be 18 ohms.

All resistances in the preceding table, "Resistances of Conductor Wires", are for the standard temperature of 68 degrees F. But you could not use the chart of Fig. 9 for translating those resistances into the values for other temperatures, because Fig. 9 applies only to copper wire, and other conductor materials change their resistance at different rates when there are changes of temperature.

For a given change of temperature the resistance of nickel changes about $1\frac{1}{2}$ times as much as that of copper. With iron the change is about $1\frac{1}{4}$ times as much, but in brass there is only about half as much change of resistance. With Constantan and Manganin, which are used where the resistance must undergo very little change, the variation of resistance with temperature is only about $1/400$ of the variation in copper.

Carbon has the peculiar property of decreasing its resistance as its tempera-

ture goes up. If you were comparing the performance of copper and carbon when they are subjected to the same rises of temperature, you would find the resistance of the carbon going down about $1/8$ as much as the resistance of copper goes up.

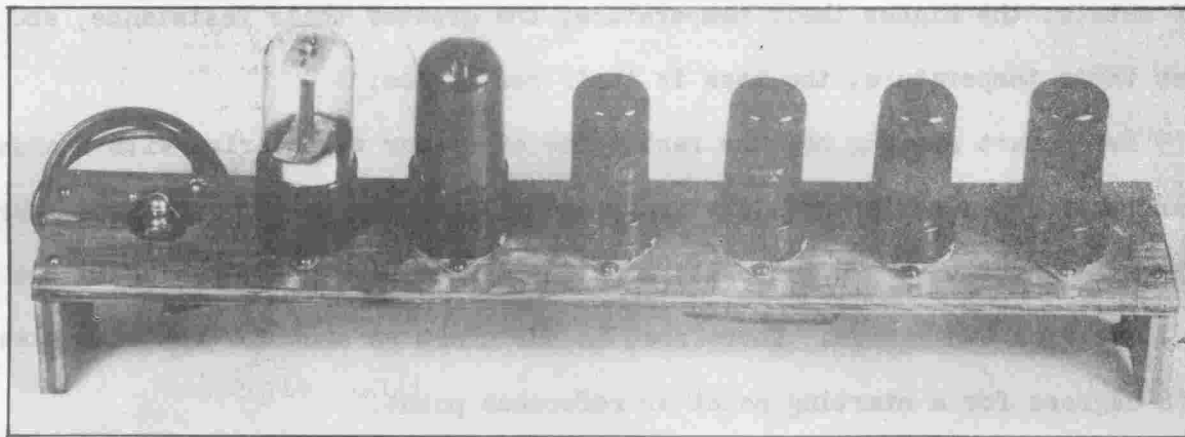

FIG.10.

Tubes for a 6-tube ac-dc superheterodyne receiver. The four toward the right have metal envelopes.

The resistance of most conductors increases with temperature because it is harder for electrons to get through a hot substance. It is harder to get through because the effect of heat on all molecules and atoms is to make them vibrate or jump around. The higher the temperature, the faster the vibration. It is harder for the electrons to move through atoms and molecules in rapid vibration than when these particles are relatively quiet. If you make a solid metal hot enough, its molecules vibrate so fast and push away from one another enough to let the solid change to a liquid. If you continue the heating, the vibration increases to such a rate that the molecules push completely away from one another, and the liquid changes to a vapor or gas.

The peculiar behavior of carbon is explained by the fact that the heat energy lets electrons escape from its atoms in very great quantities, and the resistance goes down because the tremendous numbers of extra free electrons more than make up for the extra difficulty in getting through the vibrating atoms and molecules.

MEASUREMENTS IN A TUBE HEATER CIRCUIT

We have become quite familiar with resistance as measured in ohms, also with

electron flow or current as measured in amperes, and with potential difference as measured in volts. It is time that we observe the manner in which these three factors act on one another in some typical radio circuits. For our first experiments we shall use a tube heater circuit as found in six-tube ac-dc superheterodyne receivers. Fig. 10 shows the tubes for such a receiver, mounted on a stand which will allow making test connections to various points in the heater wiring, which is shown underneath the stand by Fig. 11.

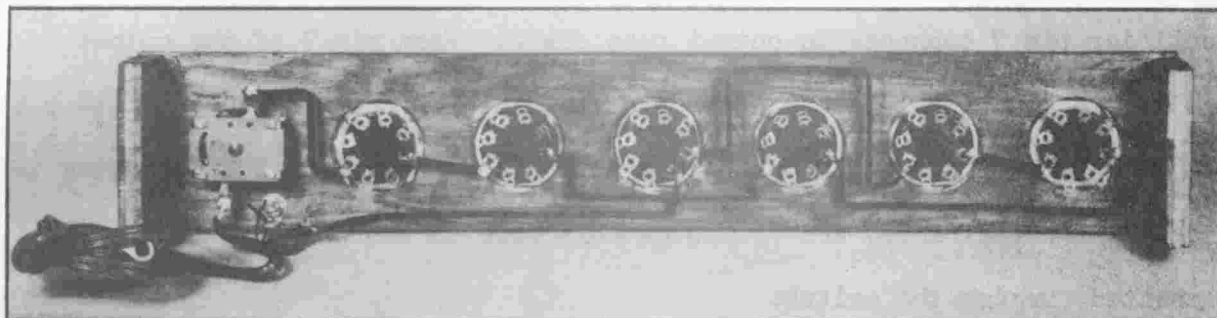

FIG. 11.
Wiring connections for the line cord, switch, and sockets.

At the extreme left is an off-on switch to which is attached one side of the line cord that would go to the wall plug with a complete receiver. The tubes, from left to right, are of the following types: Rectifier, for producing direct current or direct electron flow from the alternating potential of the supply when the receiver is operated from an alternating-current line. Output tube, which here is a type called a beam power tube. Combined detector, automatic volume control, and first audio-frequency amplifier tube. Intermediate-frequency amplifier tube. Converter tube. Radio-frequency amplifier tube. These types are the same as used in the superheterodyne receiver described in an earlier lesson, with the addition of a radio-frequency amplifier ahead of the converter or between the antenna and converter. This tube amplifies the signal from the antenna before the signal goes to the converter.

Fig. 11 shows the terminals of the octal sockets. As you will recall, the tube base pins and corresponding socket terminals are numbered from 1 to 8. In the picture the locating grooves or notches in all sockets are at the bottom. This brings

pin number 1 to the left of center at the bottom. The remaining pins are numbered in a clockwise direction: 2,3,4,5,6,7 and 8.

For all except the third tube from the left (the detector-avc-af tube) the heaters connect between base pins and socket terminals 2 and 7. For the detector-avc-af tube the heater connects between numbers 7 and 8. Now let's trace the wiring of Fig. 11. One side of the line cord goes to the bottom terminal of the switch. From the top of the switch a connection goes to pin 2 of the first tube, the rectifier. Rectifier pin 7 connects to output tube pin 2. From pin 7 of the output tube we go to pin 2 of the i-f tube, from pin 7 of the i-f tube to pin 7 of the r-f tube, from 2 on the r-f tube to 7 on the converter tube, from 2 on the converter to 7 on the detector-ave-af tube, and from 8 on this tube to the side of the line that is not connected through the switch.

The tubes, or their heaters, are connected in the order just traced to lessen the tendency toward hum from the loud speaker when the receiver is operated on alternating power. The greatest variations in current or electron flow are at the rectifier tube, and the output tube is least affected by such variations. So we

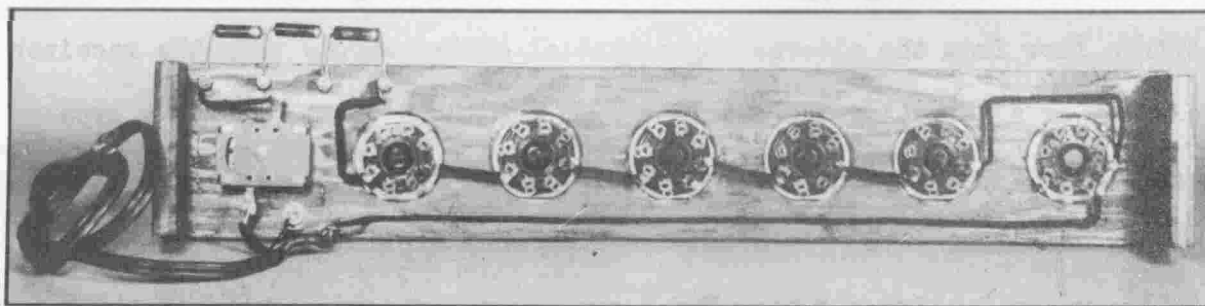

FIG.12.

The tubes are rearranged to show the series circuit more clearly.

connect from the rectifier heater to the heater of the output tube. The detector-avc-af tube is most affected by variations of electron flow in its heater, so we connect this heater as far as possible from the rectifier. The other three tubes are about equally affected by variations and they may be placed in any order between the output tube and the detector-avc-af tube. In different receivers you will find these three remaining tubes connected in various orders, but you always find the

output tube next to the rectifier, and the detector-avc-af tube farthest from the rectifier.

In Fig. 12 the tubes have been shifted so that they follow one another in the order of electron flow through their heaters, and the socket terminals have been rewired accordingly. This has been done to make it easier to check the test connections which we are about to make. Now we have, from left to right, the rectifier, the output tube, then (in any order) the r-f, i-f and converter tubes, and finally, at the extreme right, the detector-avc-af tube.

In Fig. 12 we have added, between the top of the switch and pin 2 of the rectifier tube, three fixed resistors connected end to end. Such resistors, or a single equivalent resistor, have to be used in some receiver circuits to use up some of the potential from the line supply when the full line voltage (potential difference) would force too much electron flow or current through the heaters.

In Fig. 13 is pictured our test set-up for measuring electron flows and potential differences. For the source we use a single dry cell which furnishes $1\frac{1}{2}$ volts of potential difference. For current measurement we use a milliammeter which measures current or electron flow in milliamperes, which are thousandths of an ampere. Nearly all of the currents in all radio receivers are less than one ampere in value, and it is almost universal practice to measure all currents in milliamperes. Consequently, we may as well get acquainted with such measurements right now. The "scale" of the milliammeter extends from zero (0) at the left to 10 milliamperes at the right.

For measuring potential differences we are using a voltmeter whose scale extends from zero at the left to 3 volts at the right, with division marks at every $1/10$ volt position.

The connections of Fig. 13 are shown in the form of a diagram by Fig. 14. The dry cell is represented by the symbol for a cell. The milliammeter is represented by a symbol consisting of a circle enclosing the letter "A" (for amperes), and the voltmeter is represented by a circle enclosing the letter "V" (for volts). These

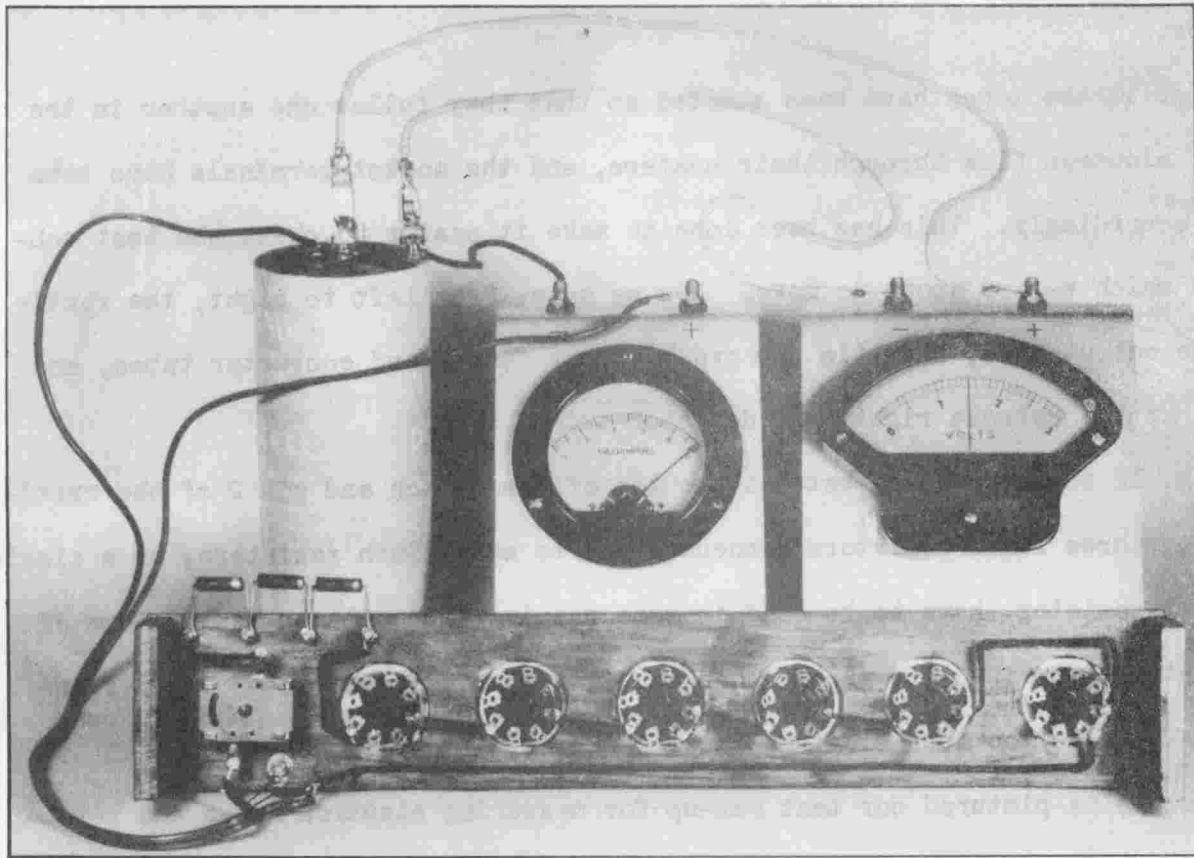

FIG.13.

The two meters and the dry-cell source ready for testing.

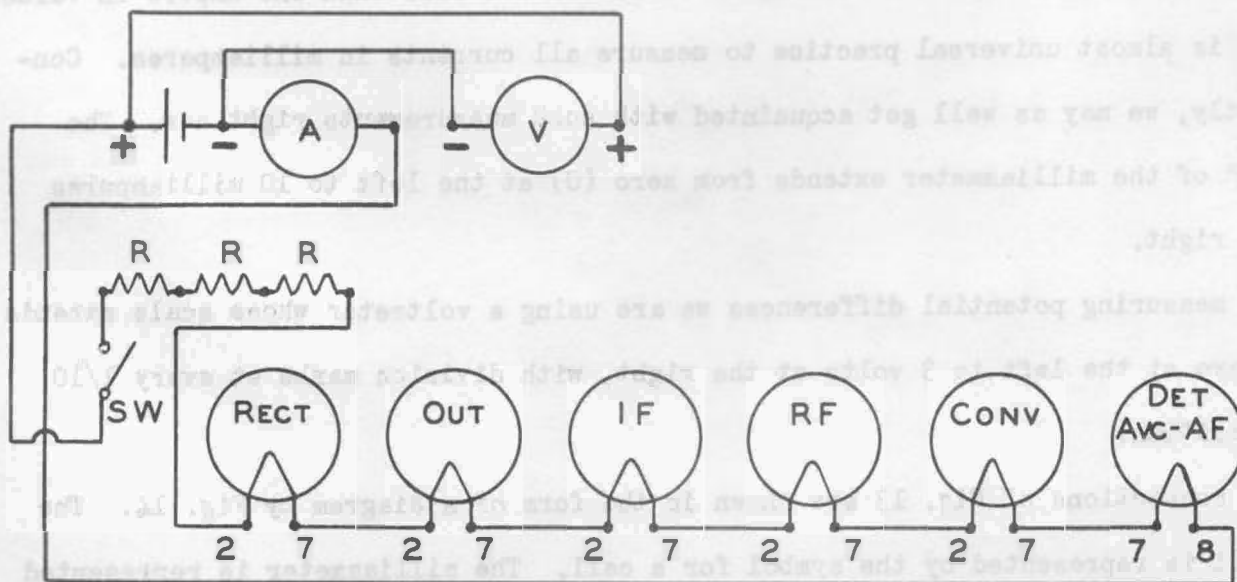

FIG.14.

How the circuit may be shown with symbols in a diagram.

are standard symbols for such meters. In the diagram the switch is shown by its symbol, marked "Sw"; the three resistors are shown by their symbols at R-R-R; and the tubes, with their heaters only, are shown by the usual symbols for heaters.

Electron flow in the circuit external to the source starts from the negative (right-hand) terminal of the dry cell, goes through the milliammeter, and then to pin 8 of the detector-avc-af tube. Then the flow proceeds through the heaters of all the other tubes, then through the fixed resistors, through the switch when the switch is closed, and back to the positive terminal of the dry cell. Fig. 13 shows that the rate of flow is 10 milliamperes or 10/1000 ampere. The voltmeter is connected between the negative and positive terminals of the dry cell, and indicates a potential difference of $1\frac{1}{2}$ volts.

Here we have what is called a series circuit. A series circuit consists of conductors and other parts connected together in end-to-end fashion so that all of the electron flow or current that passes through any one conductor or part must pass also through every other conductor and part in the circuit. Our series circuit for current includes the source (dry cell), the milliammeter, all of the tube heaters, the fixed resistors, the switch, and all of the wires connecting these parts together.

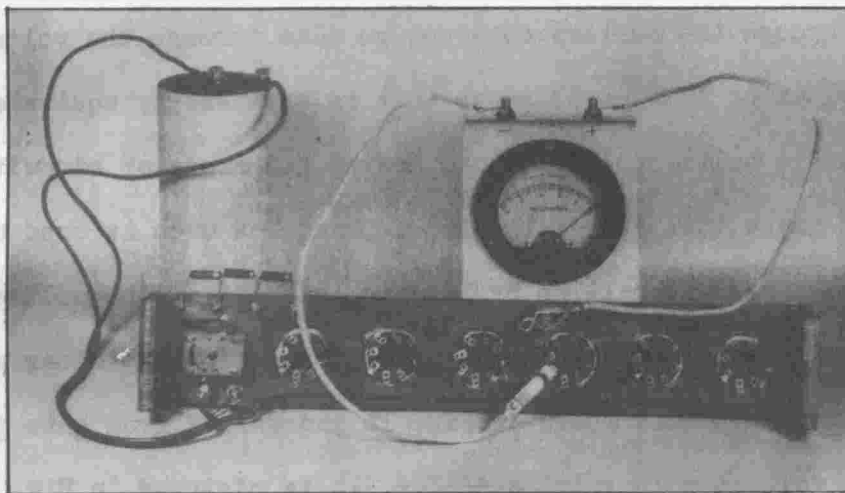

FIG.15.

Current is the same in all parts of a series circuit.

Current is the same in all parts of a series circuit. In Fig. 15 we have opened the connection between two of the tube heaters and have connected the milliammeter between the heaters. The reading of 10 milliammeters is just the same as with the meter connected

Electron flow or current is the same in every part of a series circuit. No matter where you might measure the flow in such a circuit, it would be the same as everywhere else.

In Fig. 15 we have opened the connection

at the dry cell in Fig. 13. It would be the same everywhere else in the series circuit. The voltmeter is not included in our series circuit, because any electron

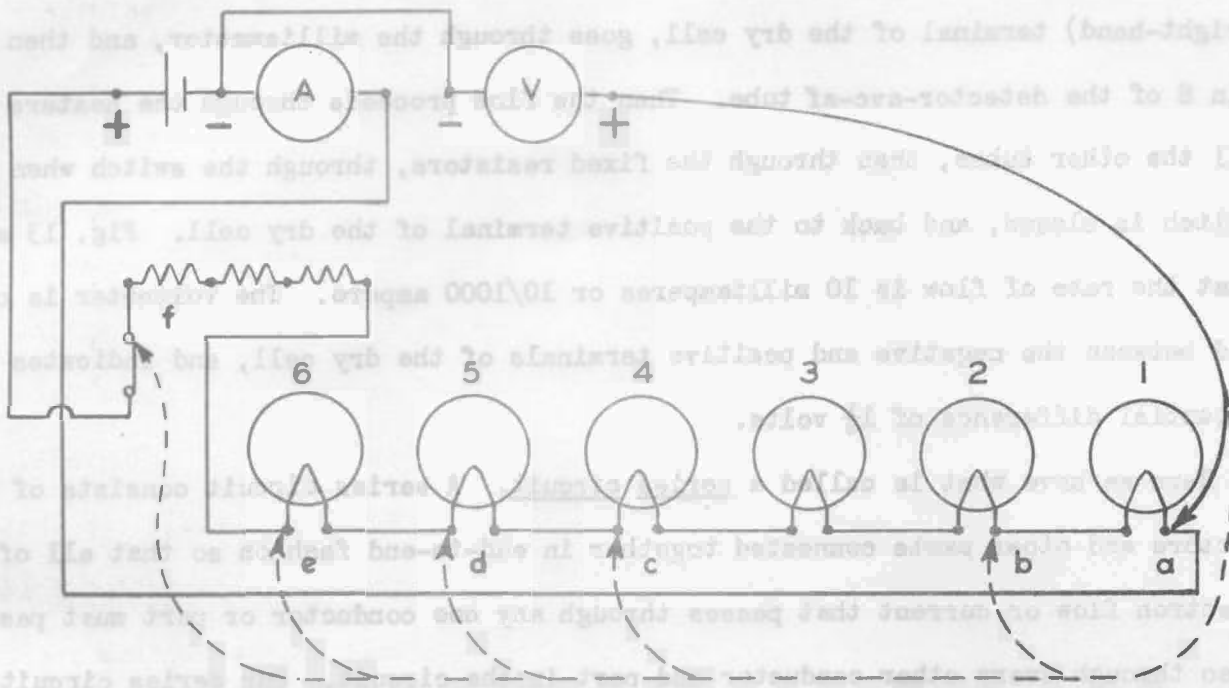

FIG.16.

The broken line connections show where the voltmeter tests will be made.

flow from the dry cell through the heaters does not go also through the voltmeter.

The reading of the voltmeter in Fig. 13 shows that we have energy equivalent to a potential difference of $1\frac{1}{2}$ volts applied to the heater and resistor circuit. Now we are going to find out where this energy is used up, and how much is used up in each part of the circuit. This we shall do by leaving one side of the voltmeter connected to the negative terminal of the source while connecting the other side of this meter successively to the points shown in Fig. 16 and marked from a to f.

The connection of the voltmeter to point a of Fig. 16 is pictured in Fig. 17.

Note that the current remains 10 milliamperes, but the voltmeter reads only about 1/10 volt. In going from the dry cell to point a the electrons have passed through the milliammeter and the part of the line cord extending from the milliammeter to terminal 8 on the socket for the detector-avc-af tube. In this much of the circuit there has been used energy corresponding to 1/10 volt of potential. Practically

all of this energy has been used by the electrons in getting through the milliammeter. The resistance of the connecting wires is negligible. The total resistance of all the connecting wires that you can see in Fig. 17 is less than $37/1000$ of one ohm. In all of our following computations we shall neglect the resistance effect of the wire connections.

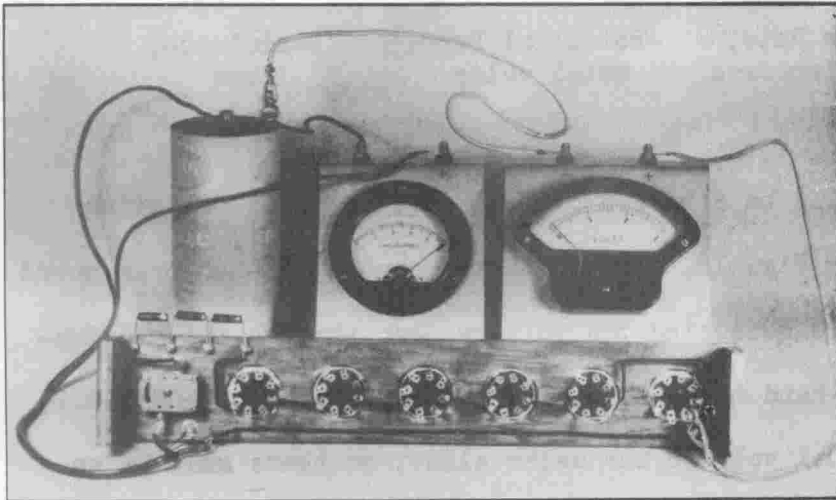

FIG.17.

Measuring the potential drop through the milliammeter.

the "volts per ampere" rule, or we divide the number of volts by the number of amperes. This would call for dividing $1/10$ or 0.1 (volt) by 0.010 ampere, which is the same as $10/1000$ ampere or 10 milliamperes. But there is an easier way. When you are computing resistances by using milliamperes of flow rate, just multiply the number of volts by $1,000$ and divide the result by the number of milliamperes.

In the present problem we have $1/10$ volt. Multiplying by $1,000$, or taking $1/10$ of

$1,000$, gives 100 . Then we divide 100 by the number of milliamperes, which is 10 ,

What is the resistance of the milliammeter. In the milliammeter there is a flow rate of 10 milliamperes and a potential difference of $1/10$ volt. Usually we would say that there is a "drop" of $1/10$ volt in the milliammeter.

To compute the meter resistance we make use of

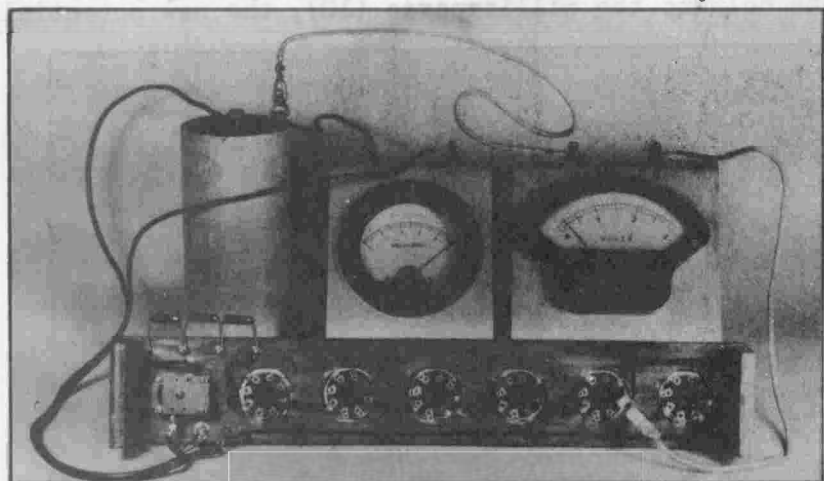

FIG.18.

Measuring the drop through the meter and one tube heater.

and find that the resistance of the milliammeter is 10 ohms. If you prefer working with decimal fractions such as 0.1 volt, which are a lot easier to handle than common fractions, such as $1/10$, you multiply the volts by 1,000 simply by moving the decimal point three places to the right. This would change 0.1 to 100.

Now take a sheet of paper and commence making up a table which will start like this:

	Flow Rate, milliamperes	Potential Drop, total volts	Resistance, ohms
Milliammeter	10	0.1	10

This table, when completed, will be a record of what we observe in following tests. The next test is shown by Fig. 18. The voltmeter connection has been moved to point b of Fig. 16. Now we are measuring the voltage drop through the milliammeter and also through the right-hand tube heater. The drop is about $2/10$ or 0.2 volt. We had a drop of $1/10$ or 0.1 volt in the meter alone, so there must be an additional drop of $1/10$ or 0.1 volt in the right-hand tube, which would make the total drop equal to $2/10$ or 0.2 volt. Evidently the heater of this right-hand tube has a resistance of 10 ohms because with the same current it has the same voltage drop as in the meter, and we determined that the meter resistance is 10 ohms. Now add to your table the note "Tube 1" in the left-hand column, and then in the appropriate columns the milliamperes (10), the new potential drop of voltage drop (0.2)

and the resistance of this tube heater (10).

For the next test we jump all the way to point c of Fig. 16 and thus include the heaters for the four tubes at the right. We make this jump because those four tubes have heaters which, in actual service, are supposed

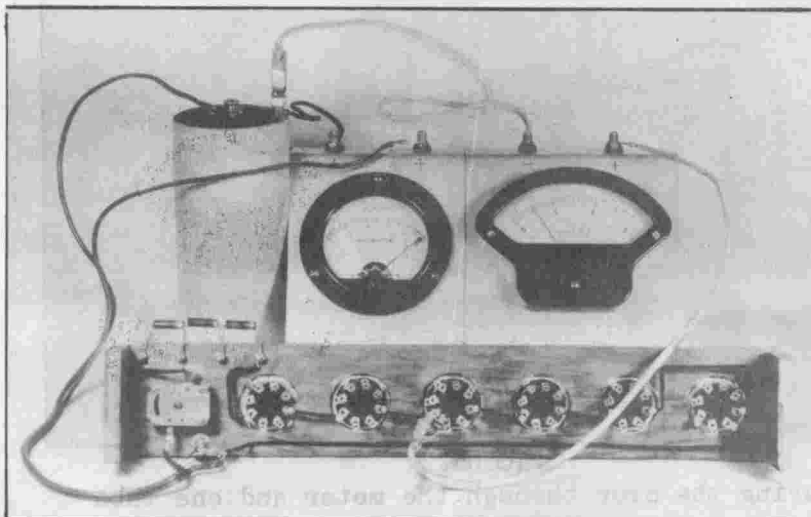

FIG. 19.

Here is included the drop in heaters of four tubes.

to have equal voltage drops. This test is pictured by Fig. 19. We still have a flow rate of 10 milliamperes, but now have a total drop of about $52/100$ or 0.52 volt. Enter this flow rate and this potential drop on your table, on a line for "Tubes 1 to 4".

The drop in Fig. 17, without any tube heaters, is 0.1 or 0.10 volt. Now, with four similar heaters, the total drop is 0.52 volt. So the drop in the four heaters must be the difference, which is 0.42 volt.

What is the resistance of the four heaters? We multiply their voltage drop, 0.42 by 1,000 to get 420. Then we divide by 10(milliamperes) to find that their

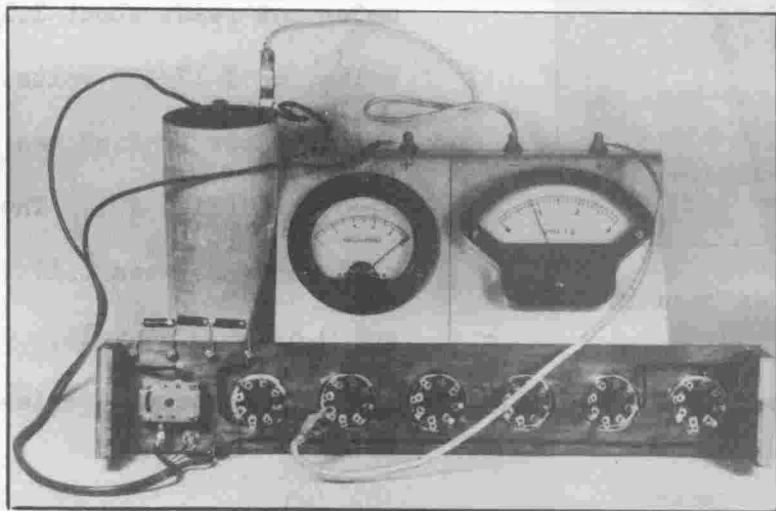

FIG.20.

Measuring the total potential drop in five heaters. have led to a value of 10.5

ohms for that tube. It is possible also that there are slight differences between actual resistances of the heaters. Variations such as between 10 ohms and 10.5 ohms seldom are important, and are nothing to worry about in measurements such as we are making. Enter 32 ohms on your table as you have already entered the resistance of tube 1.

The next test is shown by Fig. 20. The voltmeter is connected to point d of Fig. 16, so that we include the heater of the output tube. The voltmeter now reads about $83/100$ or 0.83 volt. Ahead of this output tube (Fig. 19) we had a reading of $52/100$ or 0.52 volt, so in the heater of the output tube there must be a drop of the difference, which is a drop of $31/100$ or 0.31 volt. Then we figure the resis-

tance of the output tube heater thus:

$$0.31 \text{ (volt)} \times 1000 = 310$$

$$310 \div 10 \text{ (milliamperes)} = 31 \text{ ohms}$$

Add to your table a line for "Output Tube", and on this line write the values:

10 for milliamperes, 0.83 for (total) volts, and 31 for ohms.

Now we make the test shown by Fig. 21, where we have included the heater of the

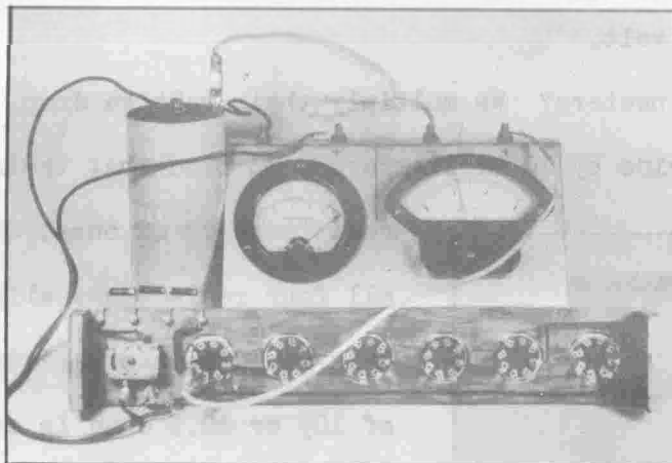

FIG. 21.

Now the rectifier tube heater has been included.

which must be the drop in the heater of the rectifier tube. We compute the resistance of this heater thus:

$$0.34 \text{ (volt)} \times 1000 = 340$$

$$340 \div 10 \text{ (milliamperes)} = 34 \text{ ohms}$$

Add to your table a line for "Rectifier Tube" and in its columns write 10 for milliamperes, 1.17 for volts, and 34 for ohms.

Finally we check for whatever potential drop or voltage drop there may be in the three series-connected resistors; making the voltmeter connection as shown by Fig. 22, and as corresponding to that for point f in Fig. 16. The voltmeter reads $1\frac{1}{2}$ or 1.50 volts, which is exactly the same reading observed away back in Fig. 13. The reading is the same because in Fig. 22 the positive(+) side of the voltmeter is connected to the top of the switch, between which point and the positive (center) terminal of the dry cell there is negligible resistance. The voltmeter is connected to the top terminal of the switch. In the closed switch there is negligible resis-

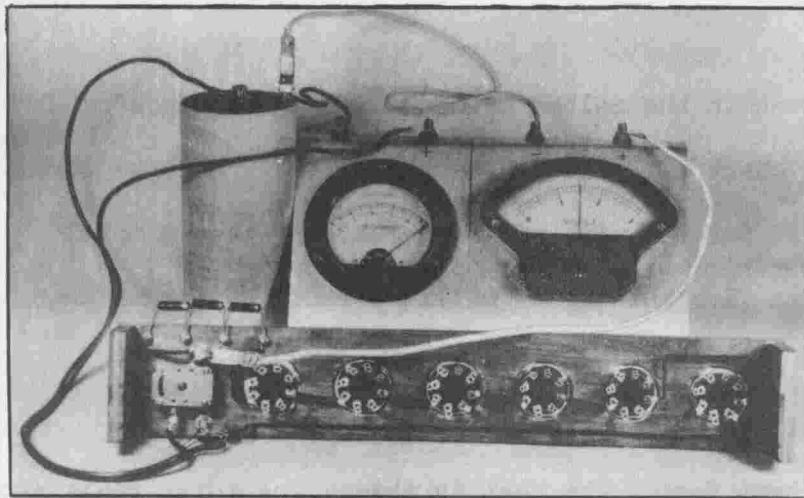

FIG/22.

Here is measured the potential drop across the entire external circuit.

leaves the potential at the top of the switch the same as at the positive terminal of the dry cell -- to which the top of the switch is connected through the switch contacts or blades and a length of wire.

The difference between the present reading of the voltmeter (1.50 volts) and the reading just ahead of the resistors (1.17 volts) is 0.33 volt. We figure the resistance of the three resistors thus:

$$0.33 \text{ (volt)} \times 1000 = 330$$

$$330 \div 10 \text{ (milliamps)} = 33 \text{ ohms}$$

Make another line on your table for "Resistors", and enter 10 for milliamperes, 1.50 for volts, and 33 for ohms. Your table now looks like this:

	Flow Rate, milliamperes	Potential Drop, total volts	Resistance, ohms
Milliammeter	10	0.1	10
Tube 1	10	0.2	10
Tubes 2-3-4	10	0.52	32
Output Tube	10	0.83	31
Rectifier Tube	10	1.17	34
Resistors	10	1.50	33

tance, and in the wire from the bottom of the switch to the dry cell there is negligible resistance. And with negligible resistance there is negligible or unreadable potential difference or potential drop, which

Now add up all of the resistances in the column headed "Resistance, ohms". The total is 150 ohms. How does this check with the "volts per ampere" rule for ohms, or with that rule as we modified it for use with milliamperes? We have a total potential drop of 1.50 volts, and a flow rate of 10 milliamperes. We figure thus:

$$1.50 \text{ (volts)} \times 1000 = 1500$$

$$1500 \div 10 \text{ (milliamps)} = 150 \text{ ohms}$$

Here we have proof of an important fact. The fact is this: The total resistance

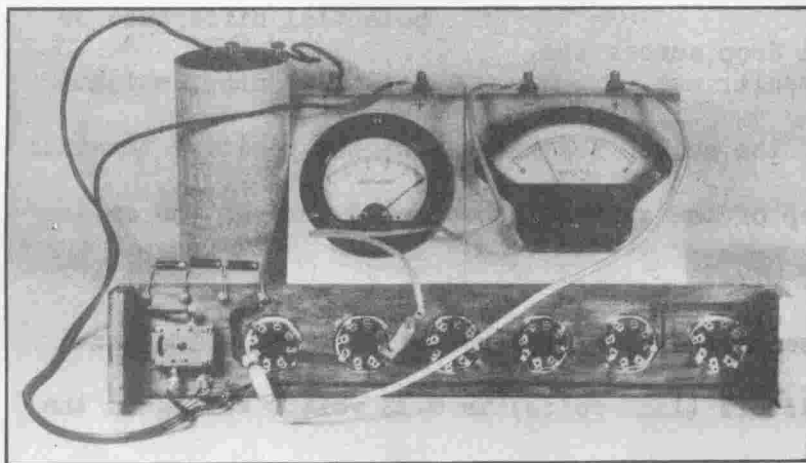

FIG. 23.

The drop across two tubes is equal to the sum of the drops measured separately.

of all parts in series is equal to the sum of the separate resistances so connected.

Let's check by measuring the combined resistance of the output tube and the rectifier tube. In Fig. 23 the voltmeter is connected across

the heaters of these two tubes. With the flow rate of 10 milliamperes the drop in the two heaters is about 0.65 volt. We compute the combined resistance, thus:

$$0.65 \text{ (volt)} \times 1000 = 650$$

$$650 \div 10 \text{ (milliamps)} = 65 \text{ ohms}$$

In your table it appears that the separate resistances for these two tubes are 31 ohms and 34 ohms, making a total of 65 ohms. This checks with the resistance as computed from the test of Fig. 23.

HOW TO COMPUTE POTENTIAL DROPS

We know how to compute the resistance of an entire circuit, or of any part or parts of a circuit, when we know the flow rate in amperes or milliamperes and know also the potential drop across the circuit, the part, or the parts considered. But note this highly important provision. The resistance, the flow rate, and the potential drop must be in the same part or the same parts. When we figure the resistance

of four heaters, as in Fig. 19, we use the potential difference across these four heaters-- not the total potential difference of the dry cell. When working with two heaters, as in Fig. 23, we measure the drop across only these two heaters -- not across all the heaters nor across the entire circuit. And all of the flow rates used in our computations must be the flow rates in the exact parts being measured.

Now we may learn how to compute potential drops, in volts, when we know flow rates and resistances. This is easier than figuring resistances, which call for dividing numbers, for potential drops are figured simply by multiplying together the flow rate in amperes and the resistance in ohms.

We may pick many examples of this rule from the table already prepared. We shall revise the table to the extent of showing potential drops across each part of the circuit rather than total drops up to certain points. The drops across the parts are found by subtracting one drop from the one following. For example, the drop in the heater of the output tube is equal to 0.83 volt (Fig. 20) minus 0.52 volt (Fig. 19), and is 0.31 volt. Here is the revised table.

Parts of Circuit	Flow Rate, milliamperes	Potential Drop, volts	Resistance, ohms
Milliammeter	10	0.10	10
Tubes 1 to 4	10	0.42	42
Output Tube	10	0.31	31
Rectifier tube	10	0.34	34
Resistors	10	0.33	33

Our rule says that potential drop in volts is equal to the product of flow rate in amperes and resistance in ohms. To use the rule as stated we should have to change milliamperes to equivalent amperes, or change 10 milliamperes to 0.01 ampere. If you multiply any of the resistances in the table by 0.01 (ampere), you get the potential drops in volts just as listed in the table.

Rather than changing milliamperes to equivalent amperes, we may multiply the number of milliamperes by the number of ohms, then divide the result by 1,000. For

example, in the heater of the rectifier tube we have 10 milliamperes and 34 ohms. Then 10 times 34 equals 340, and 340 divided by 1,000 equals $340/1000$ or $34/100$ or 0.34 volt -- which the table shows to be correct.

SERIES CIRCUIT POTENTIALS, CURRENTS, AND RESISTANCES

From the second of our tables we may learn still another important fact applying to series circuits. We know that the total potential difference applied to the entire external circuit is 1.50 volts (Fig. 13), and we know that the total potential drop in the entire external circuit is 1.50 volts (Fig. 22). Now add together the potential drops as shown by the table for all of the parts of the circuit. The total of all these drops is 1.50 volts.

Thus we find that the total potential drop in an entire series circuit is equal to the sum of the potential drops in all of the separate parts of that circuit. We observe also that the total potential drop in a series circuit is equal to the potential difference applied from the source.

Now, taking these most recent observations together with others made earlier, we have four important rules for series circuits. Here they are:

1. The current or electron flow rate is the same everywhere in a series circuit.
2. The total resistance of a series circuit is equal to the sum of the resistances in all of its separate parts.
3. The total potential drop in a series circuit is equal to the sum of the potential drops in all of the separate parts.
4. The total potential drop in a series circuit is equal to the potential difference applied from the source.

-END OF LESSON-