

**LESSON
39 R**

**DELAYED AUTOMATIC
VOLUME CONTROL**



RADIO-TELEVISION TRAINING SCHOOL, INC.

5100 SOUTH VERMONT AVENUE • LOS ANGELES 37, CALIFORNIA, U. S. A.

DELAYED AUTOMATIC VOLUME CONTROL

Although the automatic volume control systems considered thus far are quite effective in their performance and are used in most presentday receivers, a slight modification in the circuit constants further improves their application. This modification is to delay the A.V.C. action on weak signals, and such systems are known as delayed automatic volume control systems.

In the conventional automatic volume control systems discussed previously, the control action of the A.V.C. tube begins as soon as a station is tuned in and the tube is excited. This is very satisfactory on stronger stations, but on weaker stations such immediate response is not so desirable, for it only further reduces the sensitivity of the set when the signals are not strong enough to be reproduced with maximum volume. To correct such a condition the A.V.C. circuits must be designed so that the signal can be built up to a predetermined strength before the control tube begins to function.

Such delayed action can be brought about in the case of a diode rectifier by biasing the plate negatively so that the signal must build up above this bias potential before the plate will be positive and permit rectified current to flow. The expression "delayed" then refers to a signal build up rather than to time, for the A.V.C. action is delayed until the signal voltage has attained a definite predetermined value.

The delay bias is figured so that as soon as a station comes in with sufficient strength to provide full volume output, the automatic volume control action at once comes into play. The delayed control action not only increases the volume from weaker stations, but also further reduces fading from weaker or distant stations. No control action occurs with weaker signals when it is not needed or wanted. Delayed automatic volume control can therefore be defined

as a system in which the automatic volume control action does not go into effect until the actuating signal voltage has built up to a predetermined value in order to permit weaker signals from distant stations to be received with the same volume as those from nearby strong stations.

TYPICAL DELAYED AVC CIRCUITS

Various circuit arrangements are used to bring about this delayed A.V.C. action; but they all employ the same general principle, and that is to bias negatively the plate of the diode rectifier that develops the A.V.C. potential so that the signal must build up and exceed this biasing potential before A.V.C. action can take place. Two such systems are illustrated in Fig. 1 and Fig. 2.

In Fig. 1 a type 6Q7G double-diode triode is used with the two diode plates connected to function separately in two independent half-wave rectifier circuits, one as a detector-rectifier and the other as an A.V.C. potential rectifier. The upper terminal of the last I.F. transformer secondary is connected directly to one diode plate of the No. 6Q7G tube, and the rectifier circuit is closed to the lower terminal of the transformer secondary through a 500,000-ohm load resistor shunted by a .0005-mfd. filter condenser. This system serves as a half-wave rectifier-detector, and the modulated audio potential built up across the load resistor is further impressed on the grid of the triode section through the 1-megohm potentiometer grid leak which serves also as a manual volume control.

The other diode plate is also connected to the upper terminal of the transformer secondary, but through a small fixed condenser which isolates one plate from the other. As the signals come in, corresponding impulses pass through this small condenser to the lower diode plate, D-2, and make it alternately negative and positive. Further analysis of the circuit will reveal that the cathode is grounded through a 150-ohm resistor, which places it at approximately 2.5 volts above ground potential. But the lower diode is also grounded through

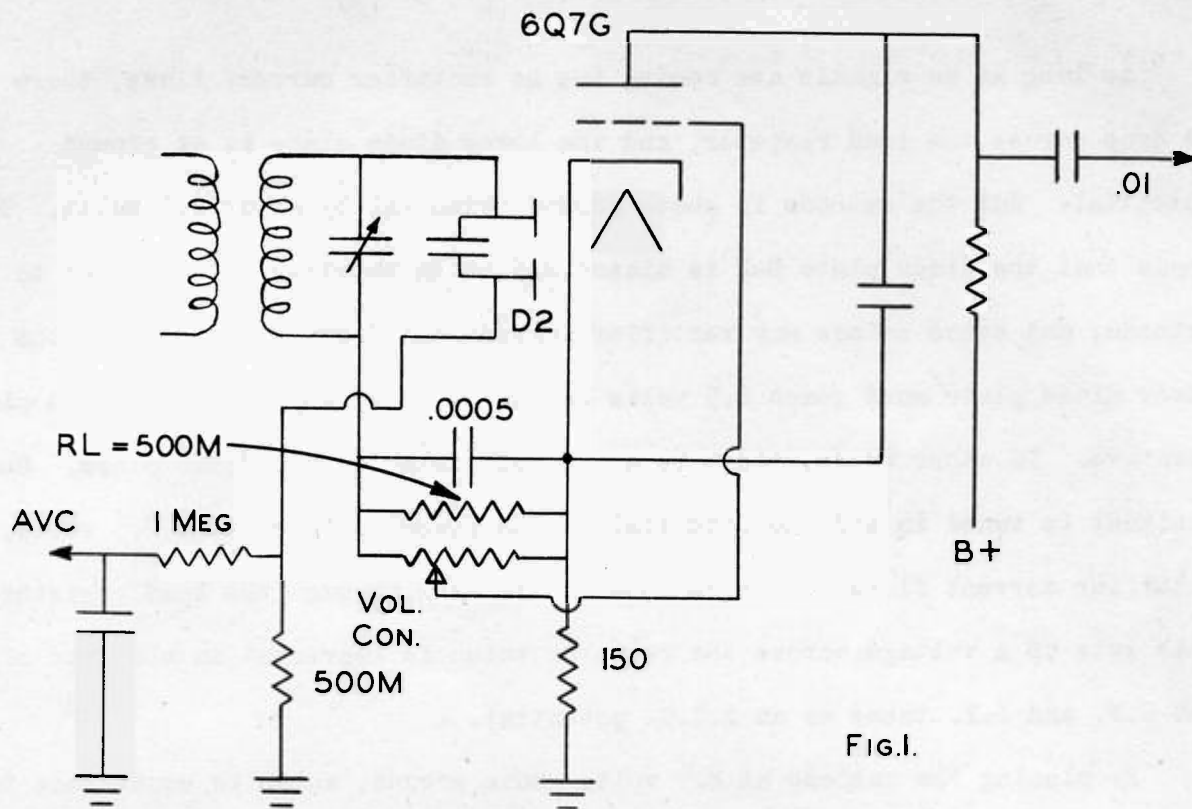

FIG. 1.

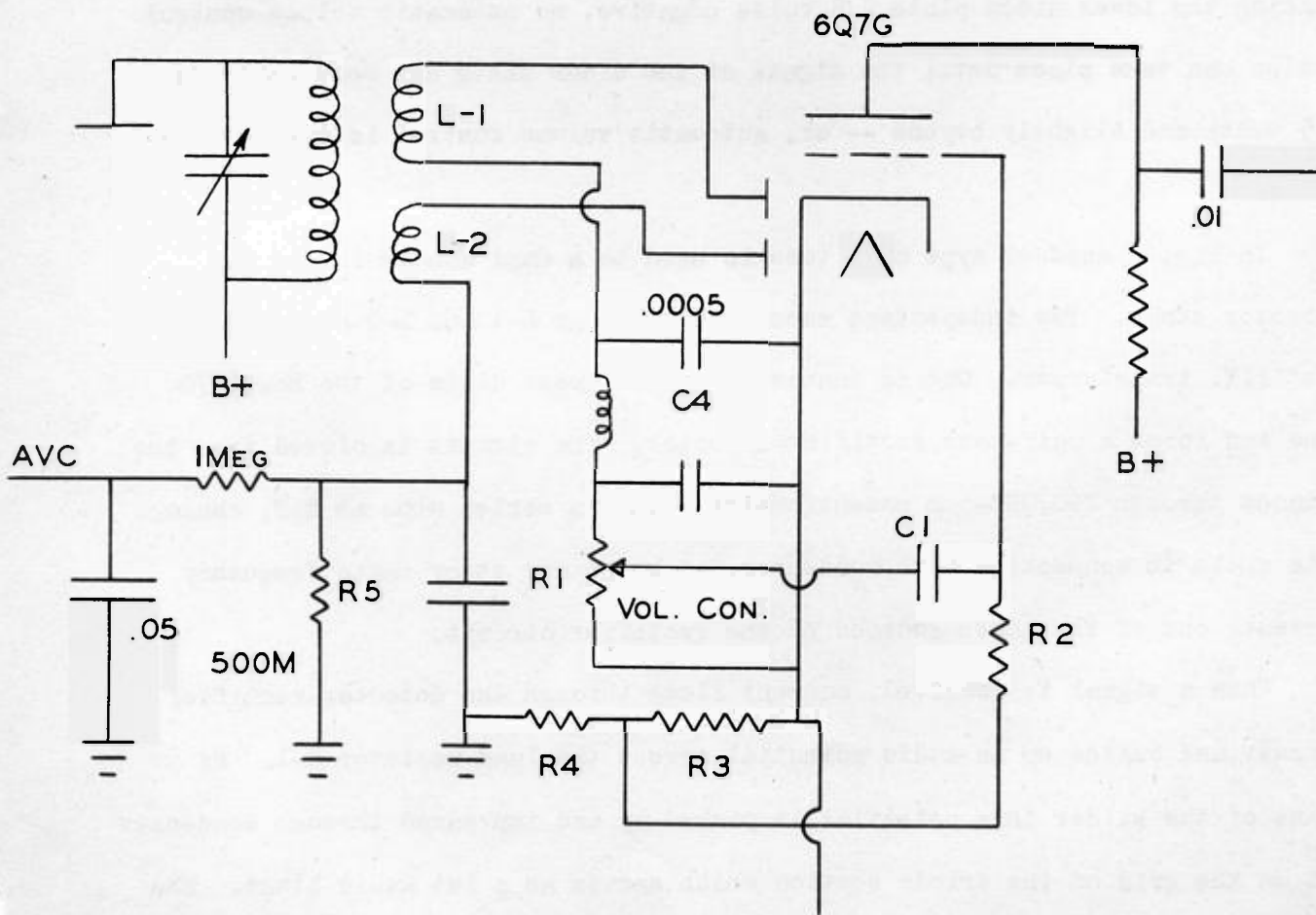

FIG. 2.

a 500,000-ohm resistor that closes this rectifier circuit through the chassis.

As long as no signals are coming in, no rectifier current flows, there is no drop across the load resistor, and the lower diode plate is at ground potential. But the cathode is above ground potential by about 2.5 volts. This means that the diode plate D-2 is biased 2.5 volts negative with respect to the cathode, and hence before any rectifier current can flow, the signal on the lower diode plate must reach 2.5 volts and go slightly beyond to make the plate positive. In other words, there is a 2.5 volt delay on the diode plate. When a signal is tuned in and the potential on the lower plate exceeds 2.5 volts, rectifier current flows to the cathode and returns through the load resistor. This sets up a voltage across the resistor which is impressed on the grid of the R.F. and I.F. tubes as an A.V.C. potential.

By placing the cathode at 2.5 volts above ground, which is equivalent to biasing the lower diode plate 2.5 volts negative, no automatic volume control action can take place until the signal at the diode plate has been built up to 2.5 volts and slightly beyond — or, automatic volume control is delayed 2.5 volts.

In Fig. 2 another type 6Q7G tube is used in a dual manner in the 2nd detector stage. Two independent secondary windings L-1 and L-2 are used on the last I.F. transformer. One is connected to the upper diode of the No. 6Q7G tube and forms a half-wave rectifier-detector. The circuit is closed from the cathode through 200,000-ohm potentiometer (r-1) in series with an R.F. choke. This choke in connection with condenser C-4 keeps any stray radio frequency currents out of the lower section of the rectifier circuit.

When a signal is received, current flows through the detector-rectifier circuit and builds up an audio potential across the load resistor R-1. By means of the slider this potential is picked up and impressed through condenser C-1 on the grid of the triode section which serves as a 1st audio stage. The

cathode is connected to R-3 on the voltage divider, while the triode grid return is brought through the leak R-2 to R-4 on the divider. Hence the voltage drop across R-3 comprises the grid bias on the triode section of the No. 6Q7G tube.

The other secondary L-2 is connected to the lower diode plate and also grounded through a 300,000-ohm load resistor R-5. But the cathode is grounded through resistors R-3 and R-4, which places it above ground potential by an amount equal to the drop across these resistors. This means that the diode plate is biased negatively in respect to cathode; and before rectifier current can flow in the A.V.C. circuit, the signal voltage must build up sufficiently to overcome this bias. Automatic volume control action is delayed until the signal has built up to a definite value as determined by the bias on the diode plate.

These two circuits illustrate nicely the principles of delayed automatic volume control. Although the circuit arrangement used in different receivers may vary somewhat, the important idea in all is to bias the rectifier plate negative with respect to the cathode. Since current can flow only when the rectifier plate is positive with respect to the cathode, the signal must build up on this plate until this negative bias is overcome before automatic volume control action can set in. In other words, the amount of negative bias constitutes the voltage delay imposed on the automatic volume control system.

AMPLIFIED AUTOMATIC VOLUME CONTROL

In amplified automatic volume control systems, as the name suggests, the signal actuating the A.V.C. tube is first amplified so that a sufficiently strong control potential may be produced to excite the tubes that are to be controlled. In other words, instead of feeding the signal directly to the control tube, it is first sent through a suitable amplifier tube and then

supplied to the A.V.C. tube. In all other respects the operation of the A.V.C. system is basically the same as the systems previously explained. Common practice is to take part of the I.F. signal and send it through an amplifier before it is rectified for A.V.C. control purposes, while the remainder of the I.F. signal may also be further amplified or else rectified in the 2nd detector and supplied to the audio amplifier in the usual manner.

58

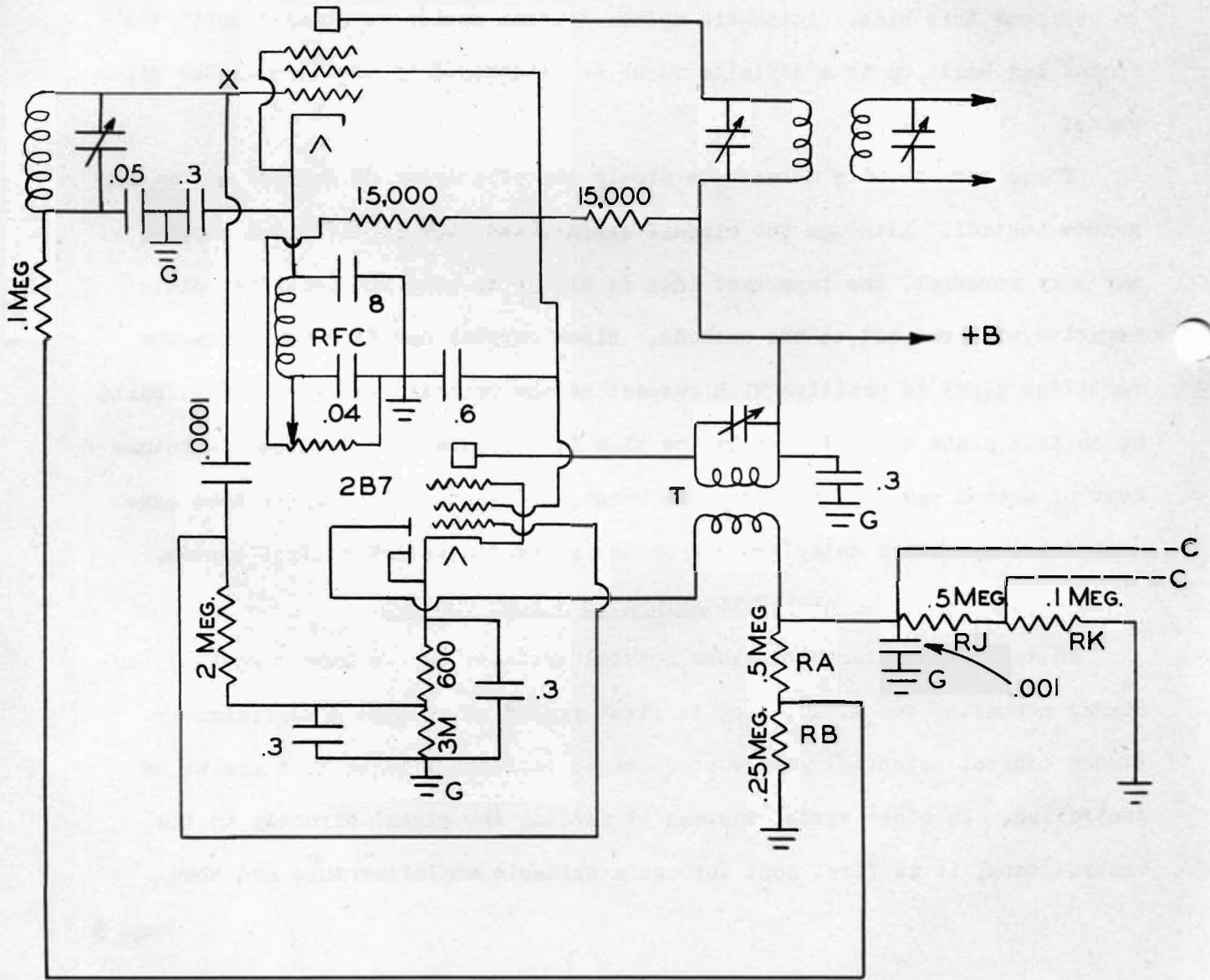

FIG. 3.

A typical amplified automatic volume control system is illustrated in Fig. 3. This scheme is used in a number of RCA-Victor receivers. Only the last portion of the intermediate-frequency amplifier channel is shown and the manner in which it is associated with the automatic volume control system. As can be seen, the last intermediate-frequency stage employs a type 58 radio-frequency pentode that is coupled through a suitable I.F. transformer to the second detector.

From a point X at the input of the above mentioned I.F. amplifier tube a tap is taken off that feeds through a 0.0001-mfd condenser to the control grid of the pentode section of a type 2B7 tube, a duodiode pentode. Here the signal is amplified and reappears in the plate circuit, where through transformer T it is coupled to one of the diodes of the tube. The signal is rectified and built up as a D.C. potential across the diode load resistors R_A and R_B . Part of this voltage is tapped off at point E and supplied as an automatic volume control potential to the grid of the type 58 intermediate amplifier tube referred to above; while the maximum voltage available at point F is supplied as an automatic volume control potential through filter resistors R_J and R_K to the control grids of the radio frequency amplifier and 1st detector tubes. The 0.001-mfd condenser in conjunction with resistors R_J and R_K determines the time constant or response interval of the automatic volume control system.

The 600-ohm resistor in the cathode of the 2B7 tube provides the biasing potential, and is supplied through the 2-megohm resistor or leak to the grid of the pentode section. Also, this 600-ohm resistor in conjunction with the 3000-ohm resistor in the cathode circuit build up a negative potential that is impressed directly on the active diode of the tube. This biases the diode negatively, and hence functions as a delaying automatic volume control potential.

In other words, before rectification can take place, the diode must have impressed upon it a positive potential that exceeds this negative bias. This means that both effects are present here -- delayed automatic volume control and amplified automatic volume control.

In conjunction with the type 58 intermediate-frequency amplifier tube, one 15,000-ohm resistor serves as a voltage dropping resistor for the screen grid; while another 15,000-ohm resistor functions as a bleeder resistor in series with a 10,000-ohm potentiometer which serves as a manual volume control by varying the cathode bias of the tube. The choke in the cathode line keeps the high frequency pulsations out of the volume control potentiometer and returns them to ground through the 0.04-mfd condenser.

Although various amplified automatic volume control systems may differ in the details of the circuit arrangement, they all operate on the same basic principle outlined above -- namely, a portion of the I.F. signal is tapped off and first sent through a suitable amplifier before it is rectified and made available as an automatic volume control potential. In most cases two intermediate amplifier stages are used, one for the channel feeding the 2nd detector, and the other for the channel furnishing the excitation for the A.V.C. tube.

THE SILVERTONE MODEL 7021 SUPERHETERODYNE RECEIVER

The Silvertone Models 7021 and 7023 are modern 5-tube superheterodyne receivers designed for operation from either A.C. or D.C. 110-volt lines. As illustrated in Fig. 4, the receivers have a built-in loop; and if the pick-up with this loop is insufficient, an external antenna can be connected as indicated. In the power supply a type 35Z5GT rectifier tube is used, and on D.C. operation the plug must be inserted into the outlet so that the positive side of the line is connected to the plate of this tube.

12SA7GT 12SK7GT 12SQ7GT 35L6GT

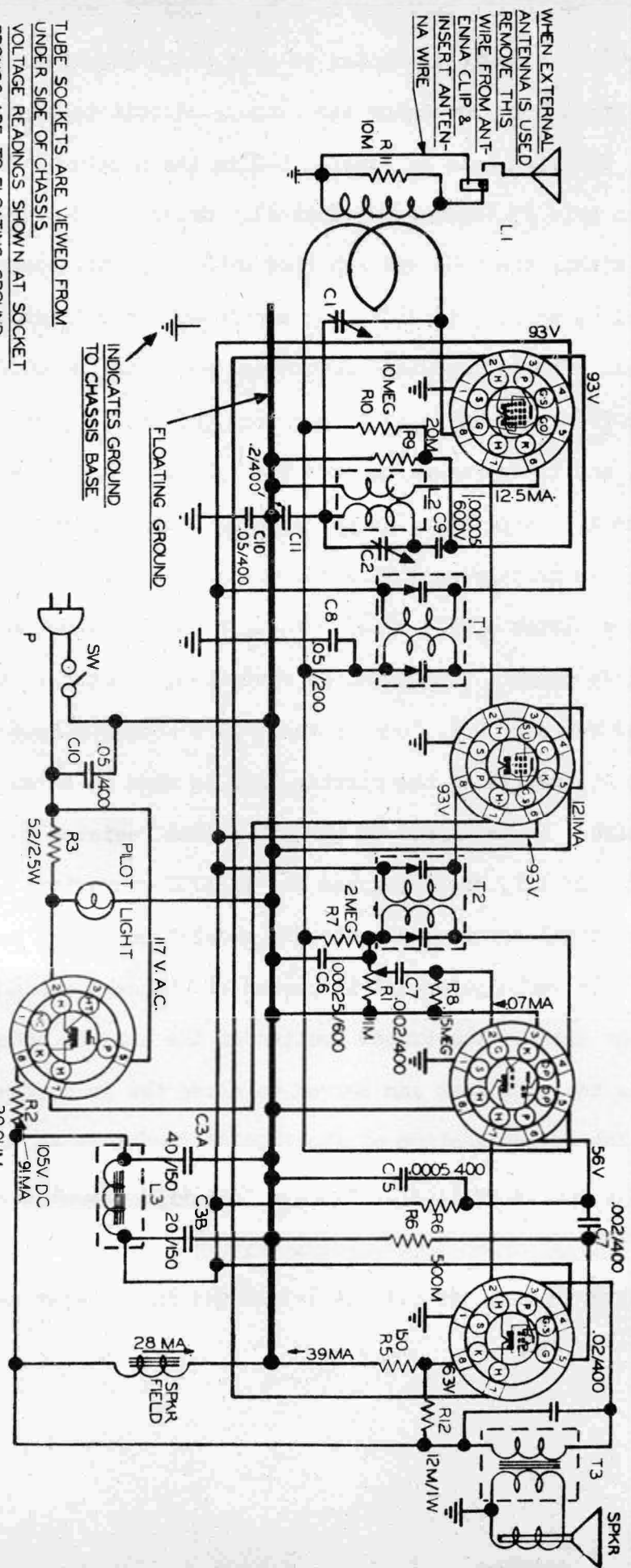

WHEN EXTERNAL ANTENNA IS USED REMOVE THIS WIRE FROM ANTENNA CLIP & INSERT ANTENNA WIRE

INDICATES FLOATING GROUND TO CHASSIS BASE

TUBE SOCKETS ARE VIEWED FROM UNDER SIDE OF CHASSIS

VOLTAGE READINGS SHOWN AT SOCKET PRONGS ARE TO FLOATING GROUND AND ARE TAKEN WITH NO SIGNAL.

A.C. LINE VOLTAGE AT 117 VOLTS.

WHERE NO READING IS GIVEN, THE VOLTAGE IS ZERO OR TOO LOW TO READ.

FIG 4

The first tube in the receiver is a type 12SA7GT pentagrid converter with the oscillator tank circuit connected to grid and 1 (terminal 5 on the socket), and feedback effected by returning the cathode circuit through a suitable tickler coil. The tank coil is labeled L-2 in the diagram. The incoming signal is impressed on grid #3 (socket terminal 8). Grids 2 and 4 are screen grids tied together within the tube and supplied with a positive potential through socket terminal 4, while grid #5 is the suppressor grid (socket terminal 1) and is grounded. The intermediate frequency, which is the difference between the oscillator frequency and signal frequency (455 Kc), then appears in the plate circuit, and is impressed through the I.F. coupling transformer T-1 on the grid of the I.F. amplifier, a type 12SK7GT high gain super-control pentode. Here the signal is greatly amplified and transferred through transformer T-2 to one of the diode plates of the 12SQ7GT tube, a double-diode triode.

In the diode circuit the signal is rectified, and two voltages are built up across the load resistor R-1. One of these is a steady D.C. potential proportional to the strength of the carrier, and is used as an automatic volume control potential. It is impressed through filter resistor R-7 onto the signal grid of the 12SK7GT I.F. amplifier and the 12SA7GT converter. The other voltage is an audio potential corresponding to the modulation signal superimposed on the carrier. This audio potential is picked off through condenser C-7 and impressed on the grid of the triode section of the 12SQ7GT tube. Resistor R-8 (15 megohms) is the grid leak and serves to close the grid return circuit to the cathode. The triode section of the 12SQ7GT functions as a 1st audio amplifier stage, and is resistance coupled to a type 35L6GT beam power output tube.

This receiver represents all the latest design features as incorporated

in modern A.C.-D.C. universal receivers. The tubes are all of the latest type, while the circuit features represent all the present day practice in receivers of this type.

THE GENERAL ELECTRIC MODEL L-740 RECEIVER

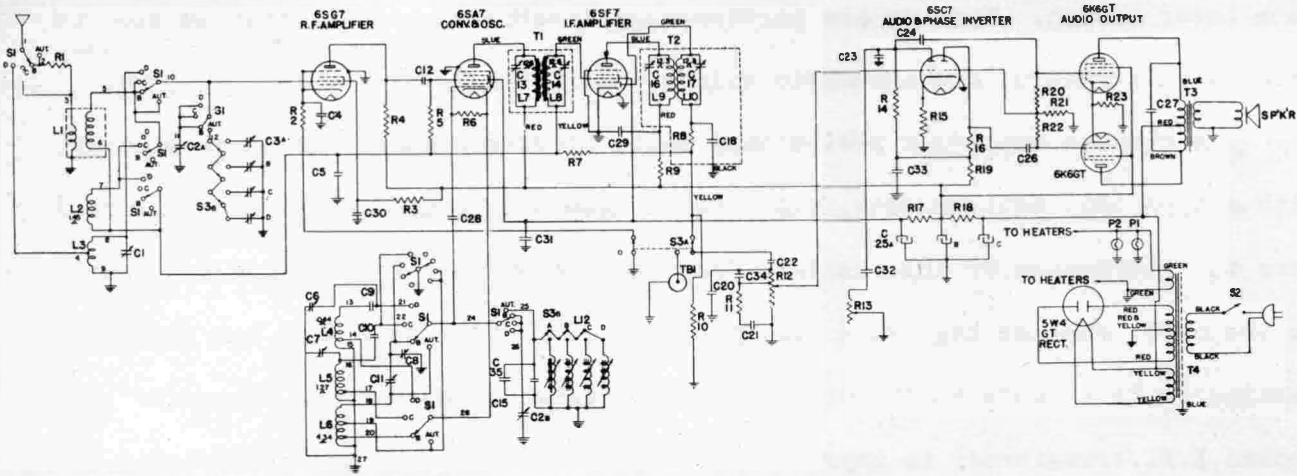

Symbol	Description
C-1	CAPACITOR—1.8-20 mmf., "D" band trimmer
C-2a, C-2b	CONDENSER—2 gang condenser
C-3a, b, c, and d	TRIMMER STRIP—Push button trimmer strip
C-4	CAPACITOR—.01 mfd. 600 volt paper
C-5	CAPACITOR—.05 mfd. 200 volt paper
C-6, 7, 8	CAPACITOR STRIP—"B," "C," and "D" osc. trimmers
C-9	CAPACITOR—4700 mmf. mica
C-10	CAPACITOR—2000 mmf. mica
C-11	CAPACITOR—"B" padder (part of C-4, -5, -6)
C-12	CAPACITOR—100 mmf. mica
C-15	CAPACITOR—600 mmf., silvered mica
C-18	CAPACITOR—200 mmf., mica
C-20	CAPACITOR—100 mmf., mica
C-21	CAPACITOR—.004 mfd., 600 V, paper
C-22	CAPACITOR—.005 mfd., 600 V, paper
C-23	CAPACITOR—.220 mmf., mica, 500 V
C-24	CAPACITOR—.02 mfd., 600 V, paper
C-25a	CAPACITOR—10 mfd., 250 V, dry electrolytic
C-25b	CAPACITOR—15 mfd., 300 V, dry electrolytic
C-25c	CAPACITOR—30 mfd., 350 V, dry electrolytic
C-26	CAPACITOR—.02 mfd. 600 V, paper
C-27	CAPACITOR—.002 mfd. 600 V, paper
C-28	CAPACITOR—47 mmf., mica
C-29, 30, 31	CAPACITOR—.01 mfd. 600 V, paper
C-32	CAPACITOR—.005 mfd. 600 V, paper
C-33	CAPACITOR—.01 mfd. 600 V, paper
C-34	CAPACITOR—47 mmf., mica
C-35	CAPACITOR—150 mmf. compensating cap
R-1	RESISTOR—470 ohm, 1/2-W. carbon
R-2	RESISTOR—220 ohm, 1/2-W. carbon
R-5	RESISTOR—4700 ohm, 1/2-W. carbon
R-6	RESISTOR—47,000 ohm, 1/2-W. carbon
R-7	RESISTOR—22,000 ohm, 1/2-W. carbon
R-8	RESISTOR—2.2 megohm, 1/2-W. carbon
R-10	RESISTOR—47,000 ohm, 1/2-W. carbon

Symbol	Description
R-11	RESISTOR—100,000 ohm, 1/2-W. carbon
R-12	VOLUME CONTROL—2 meg. volume control
R-14	RESISTOR—470,000 ohm, 1/2-W. carbon
R-15	RESISTOR—3900 ohm, 1/2-W. carbon
R-16	RESISTOR—1 megohm, 1/2-W. carbon
R-17	RESISTOR—10,000 ohm 2-W. carbon
R-18	RESISTOR—12,000 ohm, 7.4 watt, W. W.
R-19	RESISTOR—27,000 ohm, 1/2-W. carbon
R-20	RESISTOR—330,000 ohm, 1/2-W. carbon
R-21	RESISTOR—100,000 ohm, 1/2-W. carbon
R-22	RESISTOR—330,000 ohm, 1/2-W. carbon
R-25	RESISTOR—470 ohm, 1-W. carbon
R-26	RESISTOR—470,000 ohm, 1/2-Watt carbon
R-27	RESISTOR—2600 ohm, 1/2-Watt carbon
R-29, S-2	RESISTOR—2 megohm tone control and power switch
R-29	RESISTOR—100,000 ohm, 1/2-W. carbon
L-1	BEAM-A-SCOPE—"B" band loop and cabinet back assembly
L-2	COIL—"C" band R.F. coil
L-3	BEAM-A-SCOPE—"D" band loop assembly
L-4	COIL—"D" band oscillator coil
L-5, -6	COIL—"B" and "C" band osc. coil
L-12a, b, c, and d	COIL—Push button coil assembly
S-1	SWITCH—Band change switch
S-3a, b	SWITCH—Push button switch
T-1	TRANSFORMER—1st I.F. transformer
T-2	TRANSFORMER—2nd I.F. transformer
T-3	TRANSFORMER—Speaker output transformer
T-4	TRANSFORMER—50/60 cycle power transformer
T-5	TRANSFORMER—25-cycle power transformer
SPKR	SPEAKER—6 1/4 in. P.M. speaker

Fig. 5

The General Electric Model L-740 illustrated in Fig. 5, is a 7-tube A.C.

operated superheterodyne receiver that has incorporated in it all the latest design features of receivers of this type. Manual as well as automatic push-button tuning is employed, and these tuning systems will be explained in detail in a later lesson. What we are particularly interested at this time is the 2nd detector, 1st audio, and automatic volume control (A.V.C.) systems employed.

The circuit employs a preliminary radio frequency amplifier stage equipped with a type 6SG7 pentode tube, which feeds into a type 6SA7 pentagrid converter. Here the difference or intermediate frequency of 455 Kc. is produced and impressed on the 6SF7, another high gain R.F. pentode. This 6SF7 tube also has incorporated in it a diode rectifier. It is onto this diode that the output of the second I.F. transformer is impressed for rectification, and the rectified D.C. potential is then built up across the load resistor R-10 and used as an A.V.C. potential for the grids of R.F. amplifier, converter, and I.F. amplifier tubes.

The audio signal voltage is taken off through the filter composed of condenser C-22 and resistor R-12 and is impressed on the grid of one of the triode sections of a type 6SC7 tube. The other triode section of this tube functions as a phase inverter, and the two triodes thus develop two signal voltages equal in intensity and differing in phase by 180 degrees, the necessary input signal requirement for a resistance-coupled push-pull amplifier stage. The push-pull output stage here employs two type 6K6GT tubes. These tubes resemble the familiar type 41 output pentodes. The phase inverter, it will be observed, takes the place of the conventional push-pull input transformer in the secondary of which the two signal input voltages are developed 180 degrees out of phase.

THE GENERAL ELECTRIC MODELS J-1106 AND J-1108

These two General Electric Radio Receivers have all the latest design features incorporated in them. The complete circuit diagram of these receivers, as well as the parts specifications, are illustrated in Fig. 6.

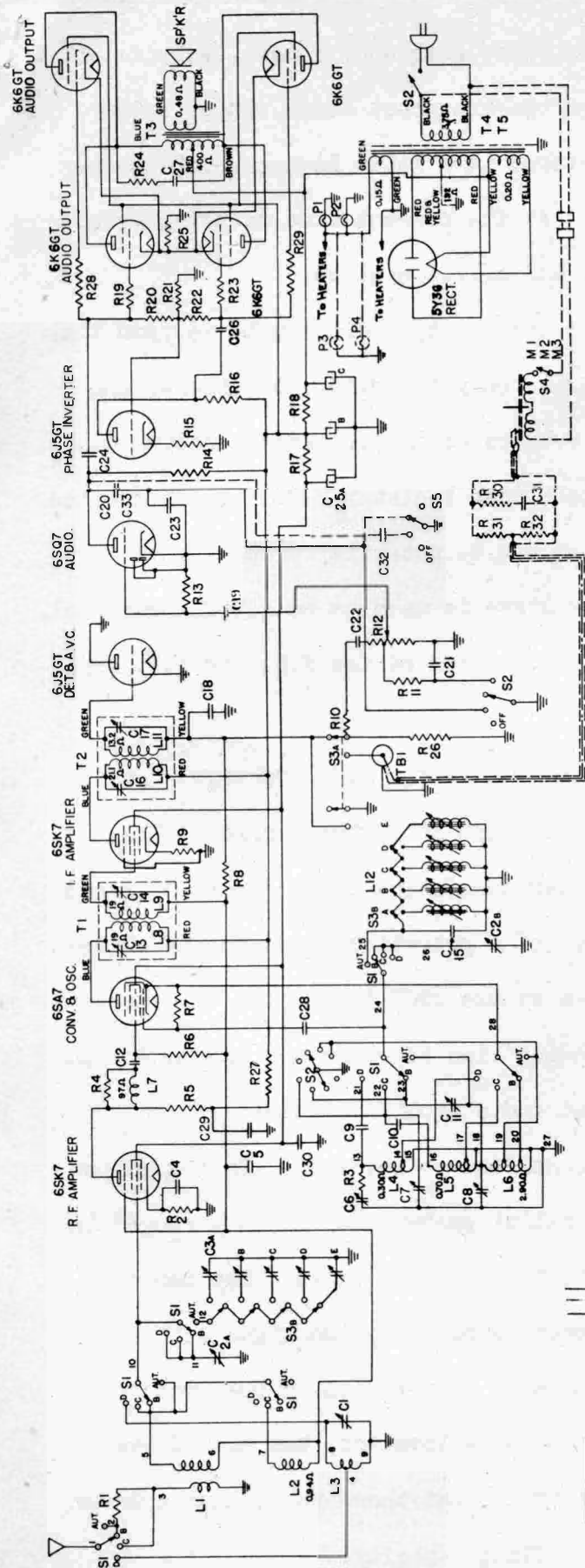

NOTE—Parts and lines shown dotted are to be added in circuit for J-1108 receiver only.

Symbol	Description	Symbol	Description	Symbol	Description
C1	2-20 mmf. trimmer	C31	.008 mfd. paper capacitor	R22	270,000 ohm carbon resistor
C2a, 2b	Tuning condenser	C32	.005 mfd. paper capacitor	R23	1000 ohm carbon resistor
C3a, b, c, d, e	Touch tuning trimmer	C33	.002 mfd. paper capacitor	R24	5600 ohm carbon resistor
C4	.01 mfd. paper capacitor	R1	1000 ohm carbon resistor	R25	220 ohm carbon resistor
C5	.10 mfd. paper capacitor	R2	47 ohm carbon resistor	R26	470,000 ohm carbon resistor
C6, 7, 8	Osc. trimmer strip	R3	27 ohm carbon resistor	R27, 28, 29	1000 ohm carbon resistor
C9	.008 mfd. paper capacitor	R4	10,000 ohm carbon resistor	R30	100,000 ohm carbon resistor
C10	2400 mmf. mica capacitor	R5	3300 ohm carbon resistor	R31, 32	220,000 ohm carbon resistor
C11	100 mmf. mica capacitor	R6	47,000 ohm carbon resistor	S1	Band change switch
C12	750 mmf. silvered mica	R7	22,000 ohm carbon resistor	S2	Tone control switch
C13	220 mmf. mica capacitor	R8	2.2 megohm Carbon resistor	S3	Station selector switch
C14	.02 mfd. paper capacitor	R9	150 ohm carbon resistor	L1	"BC" band Beam-a-Scope
C15	.003 mfd. paper capacitor	R10	47,000 ohm carbon resistor	L2	"SW1" ant. coil
C16	.005 mfd. paper capacitor	R11	82,000 ohm carbon resistor	L3	"SW2" band osc. coil
C17	.02 mfd. paper capacitor	R12	2.0 megohm volume control	L4	"SW1" band osc. coil
C18	.03 mfd. paper capacitor	R13	4.7 megohm carbon resistor	L5	"BC" band osc. coil
C19	.03 mfd. paper capacitor	R14	470,000 ohm carbon resistor	L6	RF coil
C20	.03 mfd. paper capacitor	R15	3300 ohm carbon resistor	L7	Station selector coils
C21, 22	10 mfd. dry electrolytic	R16	68,000 ohm carbon resistor	L1, 2	1st I.F. transformer
C23	15 mfd. dry electrolytic	R17	1900 ohm carbon resistor	T1	2nd I.F. transformer
C24	.03 mfd. paper capacitor	R18	1000 ohm carbon resistor	T2	Output transformer
C25a	.03 mfd. paper capacitor	R19	150,000 ohm carbon resistor	T3	Power transformer
C25b	.03 mfd. paper capacitor	R20	120,000 ohm carbon resistor	T4, T5	
C26	.002 mfd. paper capacitor	R21			
C27	.002 mfd. paper capacitor				
C28	.002 mfd. paper capacitor				
C29, 30	.01 mfd. paper capacitor				

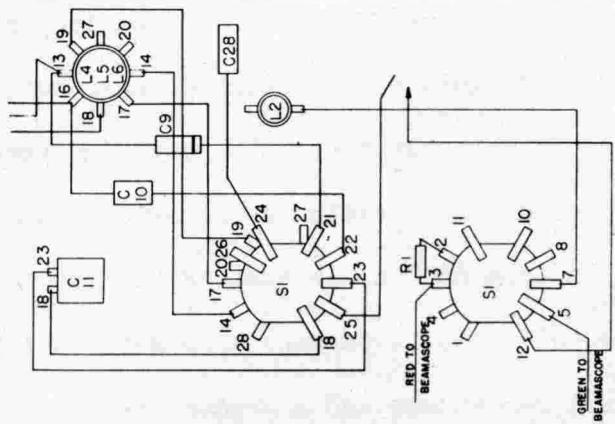

FRONT OF CHASSIS
Switch and Coil Section of Chassis Underview

FIG 6

These are 11-tube receivers, and tune over three frequency ranges, with both manual and automatic push-button tuning on the broadcast band. These automatic push-button tuners, however, are covered in a later lesson which is devoted exclusively to tuners of this type. At the present time we are interested primarily in the 2nd detector, 1st audio, and A.V.C. systems.

In the 2nd detector stage, it will be seen, a type 6J5GT tube is used that is caused to function as a diode by employing only the grid and cathode, and grounding the plate. The cathode of the tube is grounded, and the return diode current is picked up through the 470,000-ohm load resistor R-26. The rectified current builds up across this load resistor a D.C. potential proportional to the intensity of the carrier. This D.C. voltage is used as an A.V.C. potential, and is impressed as a biasing potential on the grids of the R.F. and I.F. amplifiers as well as the converter.

Also built up across the load resistor R-26 is the audio voltage that accords with the modulation signal voltage brought in by the carrier. This audio voltage is taken off through the filter consisting of condenser C-22 and resistor R-12, the latter being in the form of a potentiometer with the slider connected to the grid of the triode section of the 6SQ7 tube. The two diodes of this tube are rendered inoperative by being tied together and grounded. The triode of this tube thus functions as a 1st audio amplifier stage.

Another 6J5GT tube is used as a phase-shifter or inverter. In the output stage four type 6K6GT tubes are used in parallel push-pull. Tubes arranged in this manner yield an undistorted power output of about 6 watts. The second 6J5GT tube does not contribute anything toward amplifying the signal, it serves merely as a phase shifter or inverter. While it is more common practice to employ a type 6SC7 as an audio amplifier and phase inverter, the use of two type 6J5GT tubes is perhaps more satisfactory in that these tubes have a lower internal resistance and a greater output handling capacity.