

FLAT
POWER WIRE WOUNDS

RESISTORS AND THEIR APPLICATIONS IN RADIO CIRCUITS

**LESSON
12 RA**



RADIO-TELEVISION TRAINING SCHOOL, INC.
5100 SOUTH VERMONT AVENUE • LOS ANGELES 37, CALIFORNIA, U. S. A.

RESISTORS AND THEIR APPLICATIONS IN RADIO CIRCUITS

Resistors of various types and sizes are employed in radio receivers, depending upon the nature of the circuit in which they are used and the kind of service they have to perform. According to the purpose that they serve in a radio circuit, resistors are classed as biasing, volume control, voltage dropping, bleeder, filter, current limiting and ballast resistors. This is a large variety of applications, and in each, certain peculiar conditions must be fulfilled that call for resistors of special mechanical and electrical characteristics. The different kinds of resistors commonly used in radio receivers and their operating features are discussed in the following paragraphs.

MOULDED CARBON RESISTORS

Moulded carbon resistors are probably used more than any other type in modern radio receivers, chiefly on account of the low cost at which they can be produced. These resistors consist of a mixture of carbon or graphite with various inert materials and a suitable binding cement, proportioned according to the resistance value the units are to have. This mixture is then compressed in moulds and baked at a high temperature. For connecting them into a circuit short terminal wires are securely fastened to the ends of the resistance elements. It is very important that these terminal wires make good contact with the body of the resistor, for a poor contact may be the source of disturbing noises in the receiver.

Carbon resistors are available in all standard values ranging from 100 ohms to about 10 megohms, (10,000,000 ohms). On special order any other desired values can be obtained from the manufacturers. All resistance values are to be had in six sizes according to the amount of power to be dissipated in the resistor from 1/4th watt to 5 watts. These are shown in the illustration in Fig. 1. The smallest at the bottom is the quarter-watt size, the next the half-watt size, the third is the

1-watt, the fourth the 2-watt size, the fifth the 3-watt, and the largest at the top is the 5-watt size. The lower three are the ones more commonly employed.

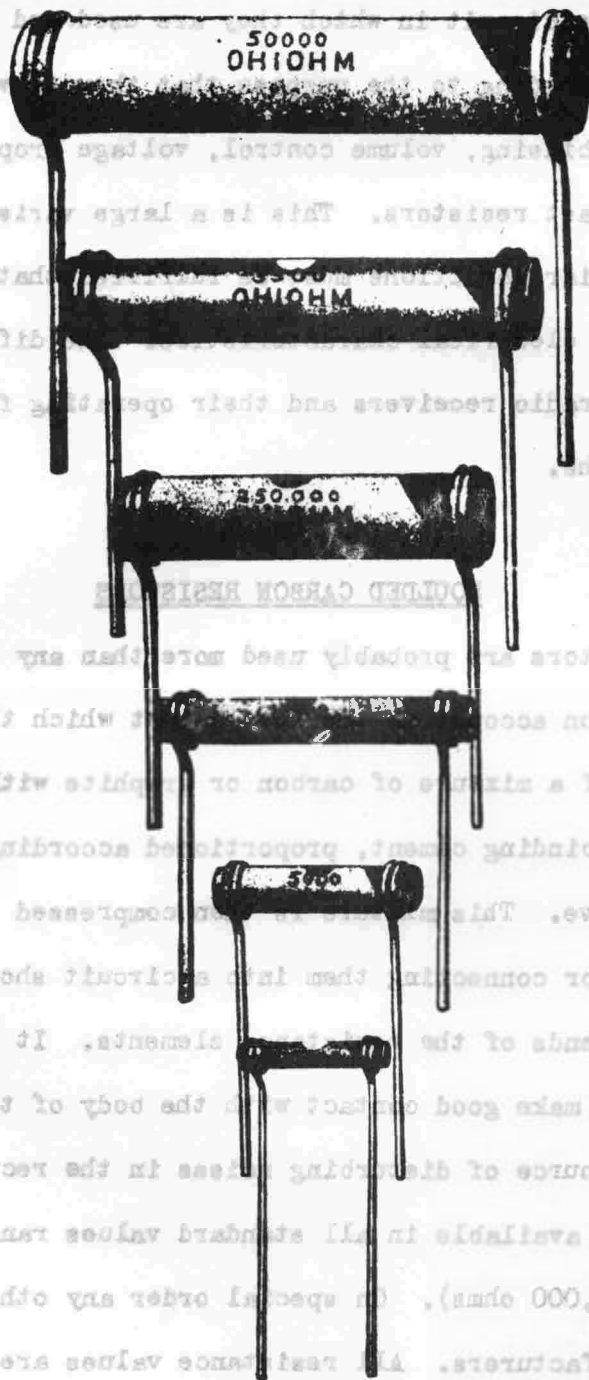

Fig. 1. Carbon Resistors. Actual sizes at different wattage ratings.

APPLICATIONS OF CARBON RESISTORS IN RADIO CIRCUITS

Moulded carbon resistors are particularly suitable for use in radio receiver circuit systems in that large values of resistance can be incorporated in very compact

and handy shaped units as illustrated in Fig. 1. Their use is limited, of course, to those parts of the circuit in which only small currents flow.

Carbon resistors are used as biasing resistors, voltage dropping, bleeder, filter and current limiting resistors. Biasing resistors are commonly used in series with the cathode return line, so that the combined plate and screen current in flowing through this resistor sets up a voltage drop that puts the cathode at a higher potential than the point to which the grid return is brought - in other words, the grid is biased negatively with respect to the cathode. The value of such a biasing resistor is obtained by dividing the biasing voltage that is to be established by the cathode current - a simple application of Ohm's Law.

Voltage dropping resistors are commonly used in series with the plate and screen grid circuits to bring about any voltage reduction that may be necessary. The value of such resistors are calculated by dividing the voltage drop that must be effected by the current flowing in that branch of the circuit, another direct application of Ohm's Law. Bleeder resistors are used in plate supply and voltage divider systems to permit so-called bleeder currents to flow. Such bleeder currents are used in two ways, one is to stabilize the power supply system and the other is to establish certain voltage relations that can not readily be arranged any other way. The latter application will be brought out more clearly later on.

Filter resistors serve to confine certain signal currents to their respective circuits and to prevent them from passing on into other circuit branches where they might cause disturbances. In this respect they operate similar to choke coils and are always used in conjunction with suitable bypass and circuit closing condensers. Current limiting resistors, as the name suggests, serve to prevent the current in a circuit from increasing beyond a predetermined value. For example, they are used in series with a volume control unit that operates on the cathode bias of the radio frequency tubes in a receiver to prevent the bias from dropping below the required minimum value.

TROUBLES EXPERIENCED WITH CARBON RESISTORS

A difficulty frequently experienced with carbon resistors is that they change their value, either due to climatic conditions or as a result of being overloaded. Moulded carbon resistors are inherently porous and hence have a tendency to absorb moisture. Consequently, in moist tropical regions, and also in the temperate zones during the summer months when the temperature and humidity run high, trouble will be experienced with many radio receivers because the resistors have changed in value sufficiently to upset the electrical balance of the circuit system. In some of the better carbon resistors these troubles are overcome by coating the resistors with a varnish or enamel that forms an impervious protective coating.

Carbon resistors will also change in value as a result of being overloaded. Overheating seems to cause partial disintegration of the resistor material and hence also a change in its resistance characteristics. Sometimes such a resistor will have a different value when hot than when cold. Therefore, when an analysis is being made of a failing receiver and it is suspected that a defective resistor is the cause of the trouble, the receiver should be left in operation for a while so that all units have had an opportunity to become properly heated, and then the resistors should be checked before they have had time to cool off. The cost of carbon resistors is relatively so low that when any doubt exists as to the fitness of a resistor, it should be replaced with a new one, for time is worth a great deal more than the small cost of a new unit.

Carbon resistors that have been overheated may also become noisy due to loose particles within the structure or poor contact between the body of the resistor and the terminal wires. Internal shorts and grounds, of course, are impossible within a carbon resistor; a resistor can only become shorted or grounded to an adjacent unit or to the chassis itself. As was stated previously, whenever the least doubt exists about a resistor, it should be replaced without any hesitancy. Whenever a case of a

defective carbon resistor comes to hand and it appears that the resistor broke down from overheating (being overloaded), it should always be replaced with a resistor of the same value but a higher wattage rating.

INSULATED CARBON RESISTORS

The insulated carbon resistor is a relatively new development. In these the resistance element itself is also of a carbon composition, but is compressed into somewhat smaller size and then surrounded with a shell of bakelite or other similar phenolic compound. This insulating coating it is claimed not only increases the heat dissipating qualities, but in addition forms an almost perfect protective coating that completely shields the resistance unit from the atmospheric elements. It also protects the resistor from becoming shorted or grounded if it comes in contact with the metal chassis or some nearby unit.

An additional advantage is that the terminal wires are held absolutely rigid in the bakelite shell and hence cannot loosen from the body of the resistor itself and produce a noisy unit. These insulated carbon resistors are also available in all standard values and in three sizes, the quarter-watt, half-watt, and one-watt ratings. Although they are somewhat higher in cost, insulated resistors can always be recommended.

METALLIZED RESISTORS

Another type of resistor that is used extensively in radio receivers where a compact high resistance unit is needed, is the metalized resistor. In this the resistance element consists of a thin film of carbon or some special metal deposited on a fine glass rod. This prepared rod is then mounted within a glass or porcelain tube that is sealed at each end with a metal cap which makes contact with the resistance element and which also has the terminal wires attached to it. On account of the thin resistance film deposit the current carrying capacity of the resistor is relatively small, and

therefore these resistors also are adapted only for circuits in which small currents are operative.

These metallized resistors are available in all commonly used values from a few hundred ohms to several megohms. They are made in three sizes, 1/2-watt, 1-watt and 2-watt, according to the amount of power that must be dissipated. They can be used wherever moulded carbon resistors are used, and are quite generally recommended for replacement purposes. One advantage claimed for these metallized resistors is that they are not so apt to change in value. At the same time they should not be severely overloaded or subjected to any abnormal conditions.

Metallized resistors are now also made in the insulated form, that is, the resistance element instead of being mounted in a glass or porcelain tube has moulded around it a phenolic insulating compound on the order of bakelite. The advantage claimed for this kind of construction is that the moulded insulation permits better heat dissipation and consequently these insulated resistors can be made smaller in size. In other words, an insulated resistor in the 1/2-watt size is no larger than the ordinary 1/4-watt carbon resistor, and consequently the need for the small 1/3 and 1/4-watt resistors is really eliminated. Insulated resistors can also more readily carry reasonable overloads without breaking down or changing in value.

At the left in Fig. 2 are illustrated several metallized resistors of natural size.

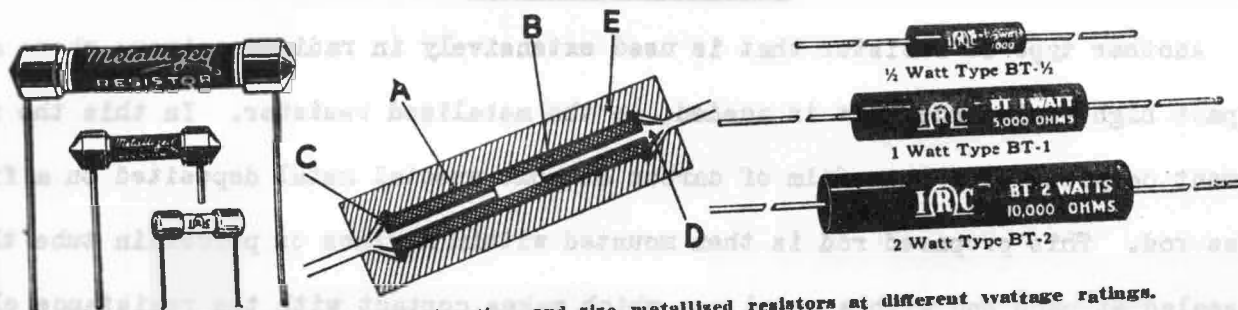

Fig. 2. Illustrating the appearance, construction, and size metallized resistors at different wattage ratings.

The resistance element is mounted in a glass or porcelain housing tube about 1/4-inch in diameter and one inch long. Over the ends of the resistor are two heavy metal caps

that make contact with the resistance elements and that also have the terminal wires attached to them. At the right in this illustration are three natural size insulated metallized resistors. In these the terminal wires enter at the center of each end of the resistor and are held securely by the insulating material. In the middle of Fig. 2 is shown the internal construction of the insulated metallized resistor. "A" is the resistance film deposited on the fine glass tube "B". "C" is the contact surface between the resistance element and the terminal wires "D". "E" is the moulded insulating sheathe or tube surrounding the entire unit.

WIRE-WOUND RESISTORS

Wire-wound resistors are used in radio circuit systems where more power must be dissipated and where greater accuracy is needed than is possible with the moulded carbon resistors. Wire wound resistors are made up in a number of different forms depending upon the resistance value and the amount of power to be dissipated.

Probably the simplest and cheapest of these is the form in which the bare resistance wire is wound on fiber strips, the ends of the wire being soldered or welded to suitable mounting terminals. Such resistors are used in battery sets as series filament resistors; they are used in A.C. operated sets as center-tapped resistors across the filament circuit, and they are also employed as grid suppressor resistors to suppress oscillation in radio frequency amplifiers - in general, they are used in low voltage circuits where only low resistance values are needed and where current leakage across the fiber strip is of little consequence. A number of different types of flat wire-wound resistors are illustrated in Fig. 3. Such units are available in values up to about 2000 ohms and with a power dissipating capacity up to 2 watts. They are more commonly used only in the low resistance values, however.

(Fig. 3 follows on Page 8.)

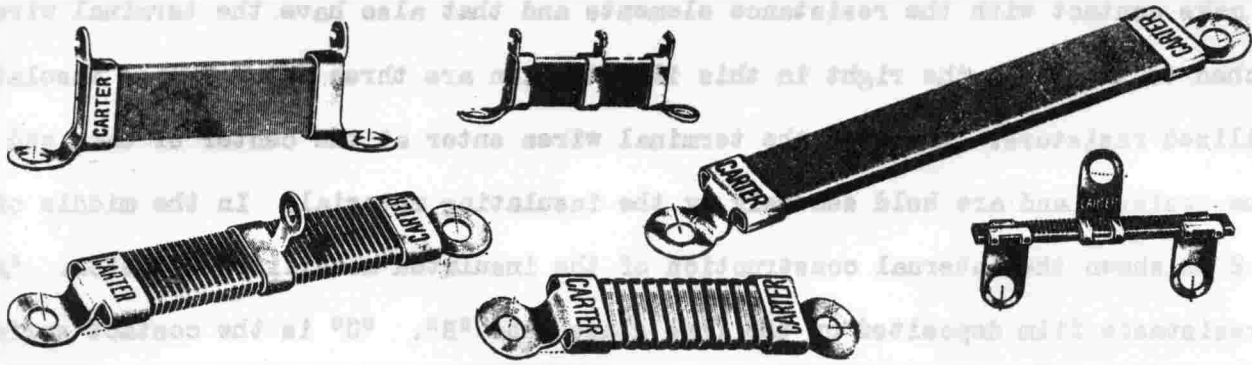

Fig. 3. Illustrating various forms of wire-wound resistors on fiber forms.

For heavy duty work, that is where the resistor is to carry larger current, such flat wire-wound resistors are made by winding the bare resistance wire on a thin bakelite strip, for the bakelite can withstand the higher temperatures better than the fiber^o can. Such resistors, however, are not employed in circuit systems in which very high voltages are operative.

VITREOUS ENAMELED RESISTORS

Vitreous enameled wire-wound resistors are used in high voltage circuits where larger amounts of power must be dissipated, as voltage dividers, etc. In these resistors the resistance wire is wound on a porcelain or other form of ceramic tube, and is coated with a special insulation enamel which upon being heated to a high temperature vitrifies and forms a protective coating that is non-porous and thus protects the resistance element against oxidation and corrosion. Some manufacturers cover such resistors with a refractory cement as a protective coating. Electrical connection is made by means of terminal leads attached to a metal ring that is clamped around the ends of the resistor and welded to the resistance wire before the enamel is applied.

Vitreous enameled resistors are available in values ranging from 1 to 100,000 ohms, and are generally made up in three sizes, 10, 20 and 50 watts. The 10-watt size is

about 5/16th inch in diameter and 1 3/4 inches long and is made in resistance values up to about 25,000 or 30,000 ohms. Above these values the current carrying capacity becomes too small to be of practical value. The 20-watt size is about 1/2-inch in diameter and 2 inches long, and is made in values up to 100,000 ohms. Where greater current carrying capacity is needed at the higher resistance values, the 50-watt size is recommended. Some companies also produce these vitreous enameled resistors in 30 and 40 watt sizes, and on special order they can be obtained with a 100-watt and even 200-watt rating.

In Fig. 4 are illustrated a number of different types of vitreous enameled wire-wound resistors. The general construction, it can be seen, is pretty much alike in all. The unit labeled "Red Devil" is a 10-watt wire-wound resistor coated with a refractory cement and is made by the Ohmite Manufacturing Company. The "Brown Devil" is a similar resistor made by the same Company but is coated with vitreous enamel. Each is also available in a 20-watt size. The smaller resistor labeled Wirewatt is a 1-watt insulated wire-wound resistor of the same size as the 1-watt moulded carbon resistor. It is well suited for replacement purposes, and under 30,000 ohms the inductive effect of the winding is negligible.

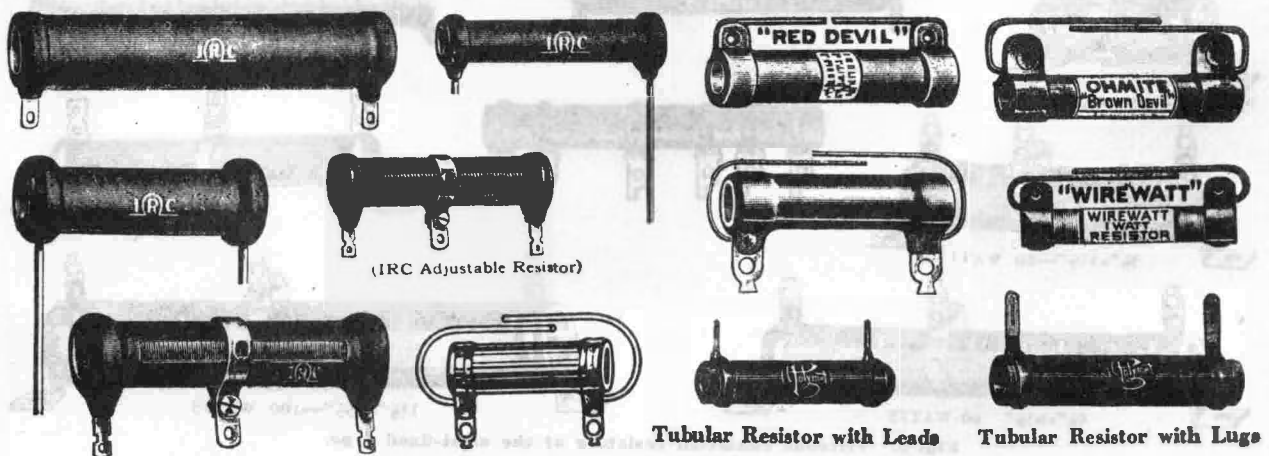

Fig. 4. Various types and sizes of vitreous enameled resistors.

Wire-wound vitreous enameled resistors are also made with taps taken off at different points along the winding, as for voltage dividers and similar purposes. Various stock values are carried by the manufacturers, and where these cannot be applied any other desired values can be obtained on special order. Such tapped resistors are made in sizes up to 100 and 200 watts and with any required resistance value.

In addition wire-wound resistors are available in a semi-fixed or adjustable form, carrying such trade names as Dividohm, Slideohm and Variohm. In these there is a narrow track along the full length of the resistor where the wire is bare and where contact is made to a sliding clamp that can be locked at any point by means of a screw driver or set screw. Any resistance value is thus obtainable from minimum to the maximum value of the resistor. A number of such semi-variable wire-wound resistors are illustrated in Fig. 5. With such resistors it is also relatively simple to build up any required voltage divider, for with two or more clamps the resistance can be broken up into any desired steps or sections.

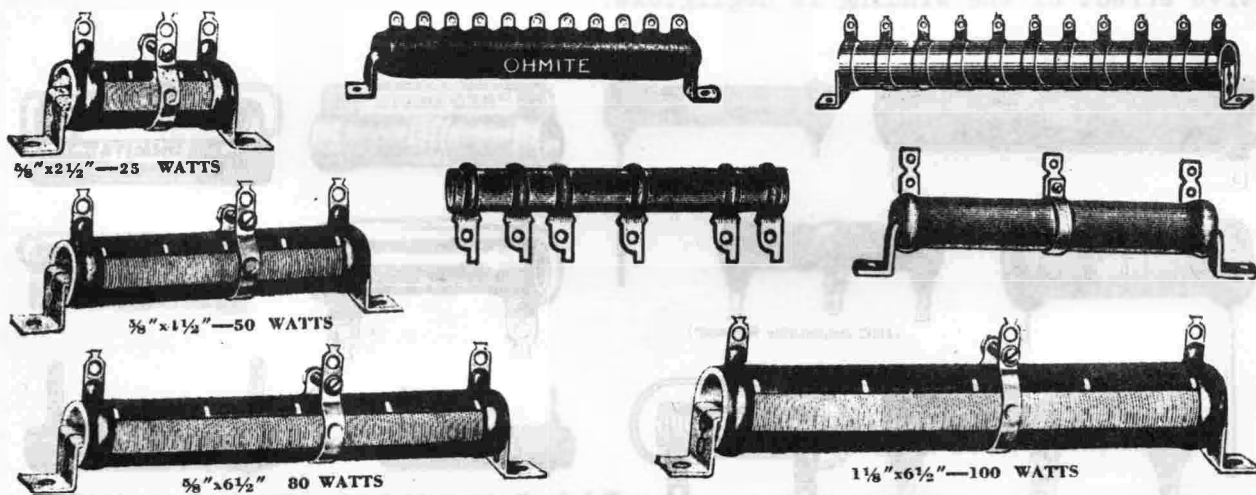

Fig. 5. Vitreous enameled resistors of the semi-fixed type.

METAL-CLAD WIRE-WOUND RESISTORS

The metal-clad or armored wire-wound resistor is another form that is used frequently in radio receivers where greater power must be dissipated, as in voltage dividers, bias resistors, line voltage dropping resistors, etc. In these metal-clad resistors the resistance wire is wound firmly on a flat strip of high temperature bakelite and has moulded around it a shell of bakelite or other similar compound of high dielectric strength. The entire unit is then covered with a metal jacket that gives good mechanical protection and that also forms a good heat dissipating contact when the resistor is mounted on a metal chassis, etc. The illustration in Fig. 6 shows clearly how such a resistor is constructed. The Candohm resistors made by The Muter Company in Chicago are similarly constructed. See Fig. 7.

Such armored wire-wound resistors are especially well suited for use in receivers that are subject to wide temperature and humidity variations, and in equipment that is exposed to penetrating industrial gasses, damp salty atmospheres, etc. They are available in various resistance ranges, from a fraction of an ohm to 15,000 or 20,000 ohms per winding inch, and with a power dissipation of 2-1/2 to 5 watts per inch. The resistors can thus be made as long or as short as is necessary to obtain the necessary values

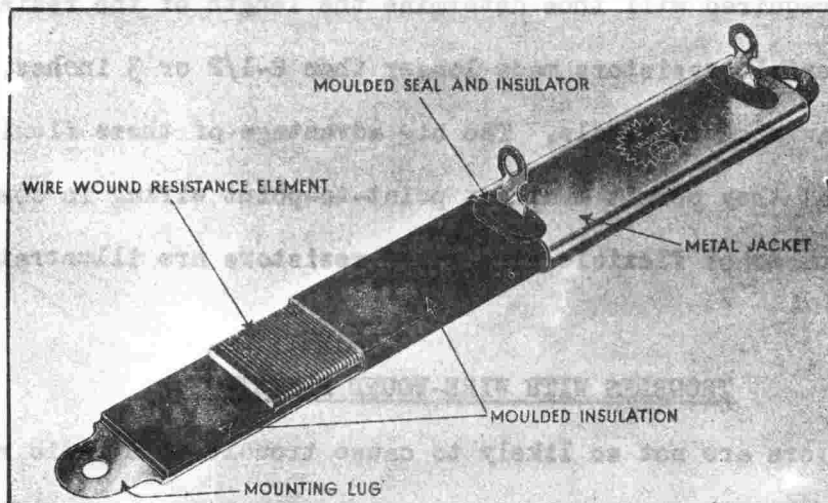

Fig. 6. Illustrating the construction of a metal-clad or armored wire-wound resistor.

WIRE WOUND CANDOHM FIXED RESISTORS

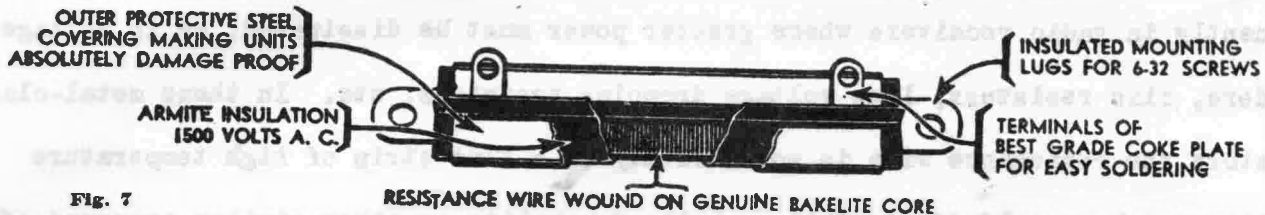

FIG. 7

FLEXIBLE WIRE-WOUND RESISTORS

Flexible wire-wound resistors are used occasionally in radio receiver construction where a compact resistor of relatively low value is needed and the stable and noiseless performance of a wire-wound resistor is necessary. In such flexible resistors the resistance wire is wound on a strong flexible core and impregnated with a suitable insulating and protecting compound. Over this is then braided a smooth flexible covering. Terminal wires are brought out at each end of the resistor.

Flexible wire-wound resistors are available in values up to 800 ohms per inch in the 1/2-watt per inch rating and up to 1600 ohms in the 1-watt per inch rating. The resistance value required will thus determine the length of the resistor. Seldom, however, are these flexible resistors made longer than 2-1/2 or 3 inches, for beyond this they are rather awkward to handle. The big advantage of these flexible wire-wound resistors is that they permit a direct point-to-point wiring in compact assemblies, etc. A number of flexible wire-wound resistors are illustrated in Fig. 8.

TROUBLES WITH WIRE-WOUND RESISTORS

Wire-wound resistors are not so likely to cause trouble in a radio receiver. A wire-wound resistor will not readily change in value, nor does its resistance vary much when hot or cold. A wire-wound resistor may become open due to a break occurring

in the resistance wire; or if severely overloaded it may burn out, that is, on account of the heat developed the wire may melt at some place. If the wire is "kinked" during the winding process, it is very likely to develop a break at that point and open-circuit the resistor. It may also happen that the insulation between adjacent turns or between winding layers breaks down which results in arcing between these turns.

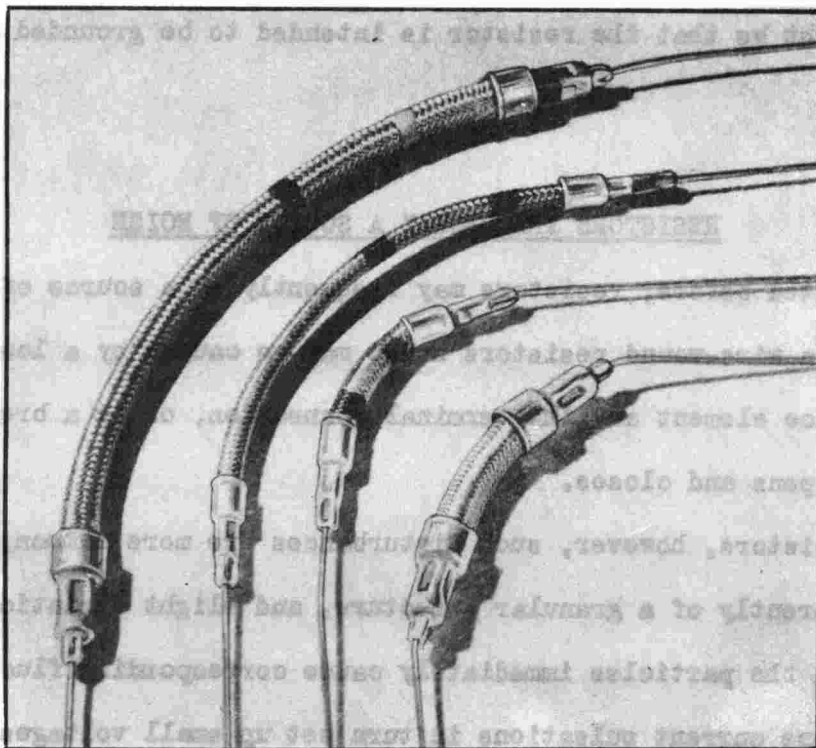

Fig. 8. Illustrating various sizes of flexible wire-wound resistors.

A frequent source of trouble is poor contact between the resistance wire and the terminal contacts. Such a condition may result in noisy reproduction or excess heat may be developed that ultimately causes the resistor to open. Wire-wound resistors often operate at a much higher temperature than do carbon resistors, but this should not be cause for alarm or reason for replacement, for wire resistors can withstand higher temperatures more readily than carbon resistors. A wire-wound

resistor, however, should never be used where the inductive effect of the winding is likely to affect the circuit characteristics. Metal-clad wire resistors may develop a ground or partial short circuit if the insulation breaks down and the resistance element touches the metal shell. In case such a condition is suspected, all connections to the resistor should be opened and the resistor removed from the chassis for final testing purposes. The circuit specifications should always be consulted, for it might be that the resistor is intended to be grounded at a certain point.

RESISTORS FREQUENTLY A SOURCE OF NOISE

As was suggested before, resistors may frequently be a source of noise in a radio receiver. In wire-wound resistors noise may be caused by a loose contact between the resistance element and the terminal connection, or by a break in the wire that alternately opens and closes.

In carbon resistors, however, such disturbances are more common, for these resistors are inherently of a granular structure, and slight variations in contact resistance between the particles immediately cause corresponding fluctuations in current flow. These current pulsations in turn set up small voltages that are amplified in the successive stages and reproduced in the speaker as noise. If the current fluctuations are rapid, they will appear as a scratchy noise, while if they are of a more intermittent nature they will be heard as a series of clicks. Noisy carbon resistors generally result from being overloaded. Excess current heats the resistor particles and causes small arcs between them. These arcs, of course, affect the current flow and cause a scratchy noise. Some of the particles may also fuse and melt together and thus cause a permanent change in the total resistance value.

A noisy carbon resistor can generally be detected by a scorched external appearance caused by overloading. When such a resistor is suspected, it should be replaced at once;

and if the external appearance indicates overheating, it should be replaced with a resistor having a higher wattage rating. Also, such a noisy resistor can often be located by tapping it lightly with a pencil or small bakelite rod. This, of course, must be done while the receiver is turned on and the resistor is at its regular operating temperature, for faults that show up while the resistor is hot often will not manifest themselves when the resistor is cold.

Special test units can be built for determining whether or not a resistor is noisy, but the cost of such a tester is usually more than is warranted by the low cost of a replacement resistor.

WHEN RESISTORS NEED REPLACING

A resistor should be replaced when it is broken down or open circuited, when it has changed in value more than 10% from that specified by the manufacturer, when it is noisy, or when it is charred or otherwise presents the appearance of having been overloaded or misused. As to the type of replacement resistor to use, this should always conform as closely as possible to the manufacturer's specifications.

When replacement resistors are being purchased, only first grade resistors should be considered made by a reliable manufacturer. In the 1-watt and 1/2-watt sizes, any standard carbon or metallized resistors can be used. But so-called bargain-price resistors should be avoided, for in the majority of cases, they are resistors that have been sold under certain conditions; and although they may be perfectly good in some cases, standard reputable merchandise is always to be preferred. Where 2-watt resistors are needed, the metallized resistors are to be recommended; and in sizes above 2-watts, wire-wound resistors should be used. In any case, the choice of a replacement resistor should always be based on the question that the resistor will give satisfactory performance in the part of the circuit where it is to be used and at the same time have a long useful life.

In midget sets, the resistor problem is more acute, for in these sets, minimum size resistors are crowded in very compact assemblies; and with the small facilities for heat dissipation, the temperatures often rise to the point at which

the resistors slowly disintegrate and change in value. If the resistors are replaced with new resistors of the same wattage rating, the same conditions again prevail and the resistors break down in a short time - and the serviceman is undeservingly condemned for having done a poor job. The only solution in such cases seems to be the use of resistors of a higher wattage rating and rearranging the parts under the chassis so that more room is provided for air circulation. This may sometimes require a partial rebuilding of the set, but it may be more desirable than to have the same trouble reappear in a short time.

A number of different schemes have been devised for checking a resistor as a source of noise, but one of the simplest means is to connect the resistor in series with a source of voltage across the primary of a good audio transformer of about 3 to 1 ratio. The secondary of the transformer is connected to the input of a good audio amplifier such as is used with a small public address system.

A well filtered d-c voltage of from 200 to 250 volts should be used in series with the resistor if the value exceed 1000 ohms. Any good electric power pack will serve well. For lower value resistors, B-batteries can be used - 45 or 90 volts. The only important points to guard against are that the voltage source itself is free from noise and that the audio amplifier introduces no noises. Any defects in the resistor will then show up by causing current variations that are amplified and reproduced in the speaker as scratchy sounds or clicks.

TOLERANCE IN RESISTANCE VALUES

In general, it can be said that the operating stability of most radio circuit systems is not very critical, and considerable deviation from calculated values is permitted before the balance is sufficiently upset to impair the performance of the circuit. This permissible deviation from the absolute values required is called the "tolerance" and is expressed in percent. The average tolerance permitted with resistors in radio circuits is 10%. This means that if a 1000-ohm resistor is specified, any value from 10% above to 10% below 1000-ohms can be used, that is, any value between 900 and 1100-ohms is permissible.

Some branches of a circuit, especially those in which heavier currents flow, demand a closer tolerance, not to exceed plus or minus 5%. Wire-wound resistors are accordingly always held to a 5% tolerance. On the other hand, in circuits in which practically no currents flow and high resistance values are employed, as the grid leaks in resistance coupled amplifiers and the filter resistors in automatic volume control circuits, tolerances as wide as 20% are permitted.

It is fortunate that such tolerances are permitted in the values of resistors, especially with moulded carbon resistors, for with these it is extremely difficult to maintain quantity production with absolutely accurate values. If close tolerances would have to be observed, there would be a great deal of waste and the cost of the resistors would be very high. The wider the permissible tolerance, the lower will be the unit price for a quantity of resistors, for then greater leeway is allowed the manufacturer. Resistors supplied to the service trade for replacement purposes are generally held to a 10% tolerance.

With meters and test instruments, greater accuracy is required in the circuit constants, and consequently the resistor values are held to a 1% or 2% tolerance. These resistors, of course, are usually wire-wound, and it is these close limits that make these resistors so costly. Where extreme accuracy is not essential, moulded carbon resistors are used extensively with a 5% tolerance.

FUNDAMENTAL CIRCUITS SHOWING RESISTOR APPLICATIONS

In Fig. 9 are shown a number of skeleton circuits illustrating how resistors are employed in connection with different types of tubes to establish the proper operating conditions. It should be remembered that the resistance values in Fig. 9 and the position of placement of the resistors are to give certain definite voltage characteristics in this particular figure although in any fundamental circuit, the applications of resistors are the same.

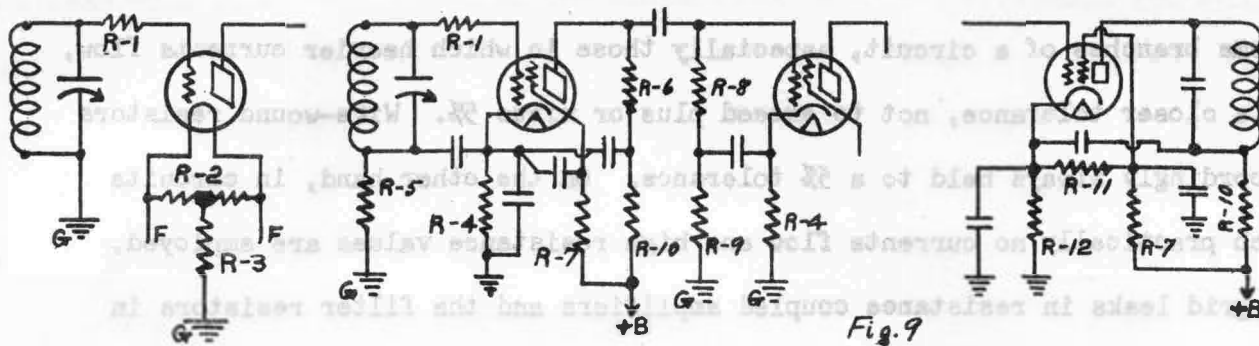

Fig. 9. Basic circuits illustrating various applications of different types of resistors.

- R-1 Grid suppressor - used to suppress regeneration and oscillation in radio frequency amplifiers. Carbon and wire-wound resistors are used, in values ranging from 50 to 2000 ohms.
- R-2 Center-tapped filament resistor - used with directly heated filament tubes to establish a midpoint across the filament circuit. Wire-wound units, either fixed or variable, are used in values ranging from 5 to 25 ohms.
- R-3 Biasing resistor - used to establish a negative bias on the grid by returning the plate current to - "B" or ground through this resistor. Wire-wound resistors are usually used, in values depending upon the bias required by the tube and the strength of the plate current.
- R-4 Cathode bias resistor - used to obtain a negative bias for the control grid by returning the plate current to -B through this resistor. Carbon or wire-wound resistor is used depending upon the amount of plate current flow.
- R-5 Grid filter resistor - used as a radio frequency filter or isolation resistor. Carbon resistor is generally used in values ranging from 25,000 to 500,000 ohms.
- R-6 Plate coupling resistor - used in resistance coupling stages in values ranging from 50,000 to 500,000 ohms. Carbon resistors are used (1/2 or 1-watt).
- R-7 Voltage drop resistor used to reduce the supply voltage to the proper value for the screen grid. Carbon resistors are used ranging from 10,000 to 60,000 ohms.

- R-8 Grid leak resistor - used in resistance coupling. Carbon resistors are used in values ranging from 100,000 to 2 and 3 megohms are used (1/2 or 1-watt).
- R-9 Filter resistor - used to confine the audio frequency signals to the grid-to-cathode circuit. Carbon resistors are used ranging in value from 10,000 to 50,000 ohms.
- R-10 Voltage drop and filter resistor - used to drop voltage to proper value required at plate. Also serves as filter to confine audio signals to plate-to-cathode circuit through by-pass condenser, and in addition to suppress hum introduced by the power supply system. Carbon resistors are used.
- R-11 Bleeder resistor - used to bleed current from the power supply for stabilizing purposes. Carbon resistors are used, the resistance value depending on the amount of current bleed that is desired.
- R-12 Bias and bleeder resistor - serves the dual purpose of providing negative bias for the control grid and completing the bleeder circuit. Carbon resistor is used, the value depending upon the circuit constants.

The above illustrations cover the more common applications of resistors in radio circuit systems.

RESISTOR TESTING AND THE OHMMETER

The troubles or defects that may develop in the various types of resistors used in a radio receiver were outlined as open circuits or burn-outs, changes in resistance value, short circuits, grounds and noise. Therefore, when a receiver fails in performance and it is suspected that a resistor is at fault, the various resistors should be checked for the above conditions. Probably the most convenient form of resistor checker is an ohmmeter, an instrument with which every radio service and repair man should be equipped, for with an ohmmeter, it is possible to check completely the operating fitness of any resistor and also determine its relation with respect to the rest of the circuit system (grounds, etc.).

An ohmmeter consists essentially of a sensitive milliammeter in series with a current limiting resistor and a small battery as a source of voltage, and arranged so that the circuit can be closed through the resistor which is to be checked. The battery voltage and limiting resistor are chosen of such values that when the ohmmeter circuit is closed without an external resistor in series, the meter pointer gives full scale deflection. When the circuit is later closed through an external resistor (the resistor which is being checked), less current will flow through the meter and the pointer will give only a partial deflection. Since the current strength at any time depends upon the external resistor value, the meter scale can be calibrated to read directly in ohms. A typical commercial multi-purpose meter is shown in Fig. 12.

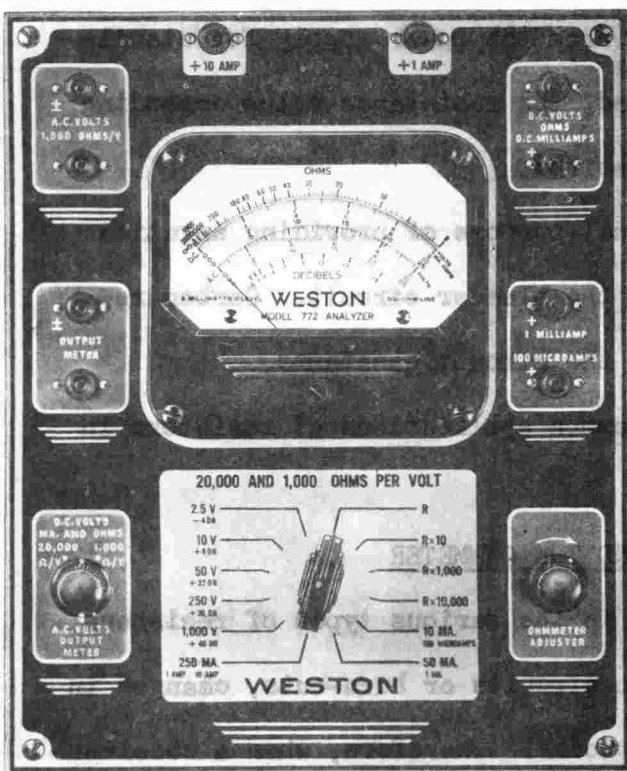

FIG. 12

Model 772 Analyzer offers a wide field of use—suitable for testing, or measuring voltages up to 1000 a-c and d-c;—current up to 10 amperes d-c—and resistances up to 30 megohms, full scale.

completely disconnected from the rest of the circuit, for otherwise the ohmmeter indication will have no meaning. The resistor may be shunted by a leaky by-pass condenser, or may form one of a number of parallel branches, all of which will affect the ohmmeter reading.

For convenience in connecting the ohmmeter across a portion of a circuit, a pair of flexible test leads are provided with insulating terminal handles that end in metal prods or points. When working with these test leads, care should be taken that the fingers do not touch the metal points, for the resistance of the human body is likely to interfere and cause erroneous meter indications.

When a suspected resistor is to be checked and tested with an ohmmeter, one end of the resistor must always be

HOW TO INTERPRET OHMMETER INDICATIONS

When the ohmmeter test prods are connected across a resistor, one end of which is disconnected from the rest of the circuit, and the meter pointer swings clear to the right to the zero position, it indicates zero resistance or a short circuit. However, it might be that the ohmmeter is being operated on a high resistance scale, say 0 to 30 megohms, and that the resistor being tested is of very low value, 8 ohms for example. Under such conditions the meter pointer would stand practically at zero and give the wrong impression. Hence, when very low resistance values are to be measured, a low range meter scale must be employed, so that a low resistance value will give an appreciable meter deflection.

When the ohmmeter is connected across another unit and the meter pointer appears not to move or give any noticeable reading, it indicates an open circuit or continuity break and the resistor needs replacement. But here also the meter action may be misleading, for if the instrument is being operated on a low range scale and the resistor being checked is of a high value, 5 megohms for instance, not sufficient current can flow through the meter circuit to move the pointer. In such a case, an ohmmeter with a high range scale should be used so that a worth-while pointer movement will be observed.

The place in the circuit where the resistor is employed generally suggests whether the resistor is of a high or low value and what range ohmmeter scale should be used. Another point to observe is the nature of the table top or bench top on which the work is being carried on, for if this is of a conducting nature due to dirt or moisture, it will permit current leakage and consequently cause the meter to give a misleading indication.

A resistor that is grounded to the chassis or to an adjacent unit can generally be detected readily by a good visual inspection, although it may sometimes require the aid of an ohmmeter to reveal the presence of such a ground. Other puzzling situations may arise now and then, but a little careful analysis work will always clear them up. In making a resistance checkup in a receiver, the

circuit diagram giving the correct values should always be referred to, in order to assist in locating resistors that might have changed their value.

EMERGENCY CONTINUITY TESTING DEVICES

In case an ohmmeter is not always available, there are a number of other schemes that can be used to check the continuity of a circuit. However, these all have their limitations, and in no way compare with an ohmmeter in ease of application and reliability.

A simple and yet very effective arrangement is the use of a set of headphones in series with a small battery, a 4-1/2 volt C-battery for example, as shown in Fig. 13. A pair of flexible test leads are attached and the circuit is closed through the resistor or coil to be checked. When the circuit is closed, current flows through the phones and a click is heard. Likewise when the circuit is opened, a click is heard. If no click is heard either time, the resistor or coil is open. Although phones used in this manner serve as a good test for continuity, they give no indication of resistance value. It is best to rely on an ohmmeter and know the relative amount of resistance introduced in the circuit by the components used.

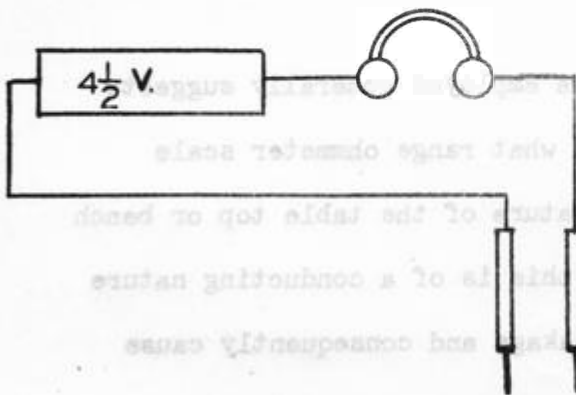

The click in the phones will be of about the same intensity when the resistance is of a medium or low value as when the resistance is zero. Hence it is impossible to distinguish between a short circuit and a circuit having some resistance, even up to

FIG. 13 A simple continuity indicator.

several thousand ohms. The metal phone tips should never be held in the fingers

while a test is being made, for the resistance of the body may cause a misleading indication.

Sometimes a buzzer is used in series with a small battery, or a flashlight bulb and a battery, but each of these is even more limited in its applications, for they will work satisfactorily only as long as the resistance of the circuit under test is relatively low. As soon as the resistance rises, the current becomes too weak to appreciably affect the indicating devices.

CHECKING RESISTORS BY THE SUBSTITUTION METHOD

Checking resistors by substituting others for each one in a circuit is a rather tedious process, but there are times when this is the only method that can be employed, especially when no data is available regarding the value of a broken down resistor, or if the resistor carries no color code. It is then a case of trying different resistor values until approximately correct circuit voltages are obtained. Generally the position in the circuit where the resistor is used will suggest just about what the value should be. The substitution method is purely a process of elimination until a resistance value is found that appears to restore normal circuit operation. It is possible to use a decade resistance box which is a device having three or more switches arranged to introduce a specified amount of resistance in the circuit. The rotary switches being calibrated in tenths, hundredths, thousandths and ten-thousandths ohms respectively. It is thus possible to merely look at the final settings of the switches and determine the exact amount of resistance that will give satisfactory results.

TUBE-TYPE WIRE-WOUND RESISTORS

Resistor manufacturers have developed a tube-type resistor for voltage-reducing purposes and for supplying needed voltage for pilot lamp operation in A.C.-D.C. receivers. These tube-type resistors are strictly non-inflammable, with the resistance element wound on a mica form firmly secured in the metal tube and connected with the base prongs as shown in Fig. 14.

To simplify servicing of receivers using tube-type resistors, manufacturers of these resistors have selected the most popular valves for so-called universal

numbers serving most replacement needs. Standard resistor tubes of the most popular types are listed below.

**STANDARD
RESISTOR TUBES**

Cat No.	Cat.No.
BK-29-B	K-90-B
BK-29-D	K-90-B
BK-32-D	K-92-B
BK-36-D	K-26J-218
BK-36-H	L-42-B
BK-49-B	L-49-H
BK-42-B	L-49-A
BK-55-B	L-49-C
BL-42-B	L-49-B
BL-42-D	L-49-D
BM-55-B	L-55-B
K-36-D	M-49-B
K-42-A	M-86892-9
K-42-B	10-610
K-42-D	100-37
K-49-A	100-70
K-49-C	100-77
K-49-D	5459
K-49-H	
K-55-A	
K-55-B	
K-55-C	
K-55-D	
K-55-H	
K-67-BJ	

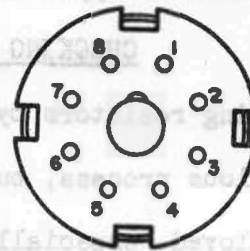

The following nomenclature details will indicate respective characteristics of the tube-type resistors

FIG. 14 Metal tube-type wire-wound resistor and tube base prong numbering arrangement shown at the right.

made available. The prefixes K, L and M indicate the number of the pilot lamp to be used. For example: K denotes 6.3 volts - 150 ma. - No. 40 pilot lamp; L denotes 6.3 volts - 250 ma. - No. 46 pilot lamp and M denotes 6.3 volts - 200 ma. - No. 51 pilot lamp. The numeral indicates the total voltage drop across the plug-in resistor tube resistance unit. The suffixes, A, B and C, designates the number of taps for the following number of lamps as listed below.

- | | |
|------------------------------------|---|
| A - No pilot lamp taps. | E1 - 1 pilot lamp tap for 3 lamps. |
| B - 1 pilot lamp tap for 1 lamp. | F - 1 pilot lamp tap for 1 lamp. |
| C - 1 pilot lamp tap for 2 lamps. | G - 1 pilot lamp tap for 2 pilot lamps.
(Tapped sections isolated from main reducing body.) |
| D - 2 pilot lamp taps for 2 lamps. | H - 2 pilot lamp taps for 2 pilot lamps.
(Tapped sections isolated from main reducing body). |
| E - 3 pilot lamp taps for 3 lamps. | |

Then the letter "J" following any of the suffixes denotes a shorted connection between two prongs of the tube, that is, K-49-BJ, the short is located between prongs numbered 3 and 4. Whenever replacing any tubes whose number ends in "J", care must be taken as the shorted pins are not always as in this example. Some are between prongs numbered 6 and 7, and others between prongs 3 and 5. It is important when replacing any tube-type resistor designed for several different types of sets or whenever using a universal tube-type resistor, that you first check the resistance of the tube which is being removed or replaced. Be sure to cut off the prongs not used on the universal tube-type resistor. Fig. 15 shows the base wiring diagrams for these pilot lamp connections.

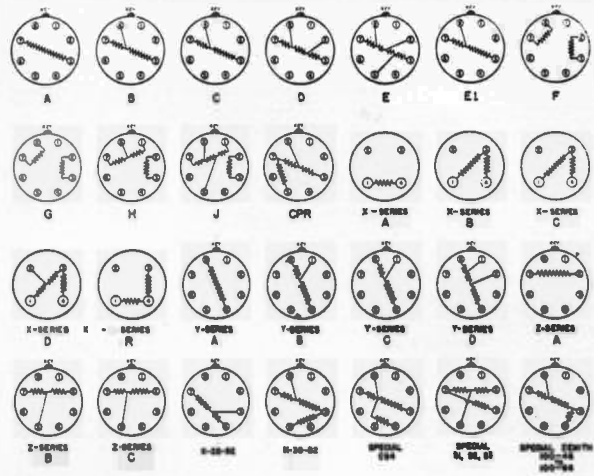

FIG. 15 Base wiring diagram of tube-type resistors.

Below you will find listed ten different universal tube-type wire wound resistors made by the Clarostat Manufacturing Company, Inc.

UNIVERSAL RESISTOR TUBES

Universal Tube No.	Replaces AC-DC Tubes Beginning with Letters	Having Numbers From	Ending in Letter
10*23-A	BK, BL, K, L, M	10 to 23	A, B, C, D
10*23-E	BK, BL, K, L, M	10 to 23	E
10*23-F	BK, BL, K, L, M	10 to 23	F, G, H
23*55-A	BK, BL, K, L, M	23 to 55	A, B, C, D
23*55-E	BK, BL, K, L, M	23 to 55	E
23*55-F	BK, BL, K, L, M	23 to 55	F, G, H
60*92-A	BK, BL, K, L, M	60 to 92	A, B, C, D
60*92-E	BK, BL, K, L, M	60 to 92	E
60*92-F	BK, BL, K, L, M	60 to 92	F, G, H
92*105-A	BK, BL, K, L, M	92 to 105	A, B, C, D

radio sets. These units come in several styles. made by the Clarostat Manufacturing Company, Inc.

AUTOMATIC LINE VOLTAGE REGULATORS

To maintain a constant line voltage for radio sets in areas where the power lines are not in first-class condition, special handy tube saving resistors are available for nearly all types of Fig. 16 shows two styles or types. The small unit is provided with convenient spring clip prongs to be inserted in the wall outlet. The power cord plug may be inserted in the top of the unit. Do not mount these units in a congested area for their operating temperature affects the voltage drop across them. These special line voltage regulators introduce

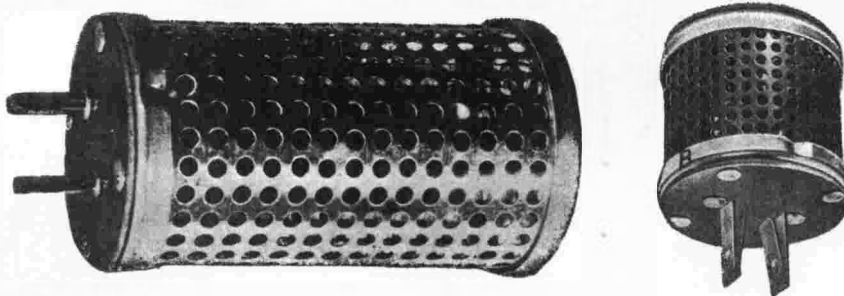

FIG.16 Typical Automatic Line Voltage Regulators

safeguards against line voltage surges or increases even up to 140 volts. At the normal 110 volts, the resistance of this type of unit is low and the voltage drop across it is negligible. However, as the line voltage increases, the resistance of the unit increases proportionally with a constant increase in voltage across it. This automatic voltage control or ballast action insures a steady, practically constant, and always safe operating potential is applied to the set.