

*America's Oldest Radio School*



*A Radio Corporation  
of America Subsidiary*

HOME OFFICE  
75 Varick Street, New York

NEW YORK, N.Y. CHICAGO, ILL. PHILADELPHIA, PA. BOSTON, MASS.

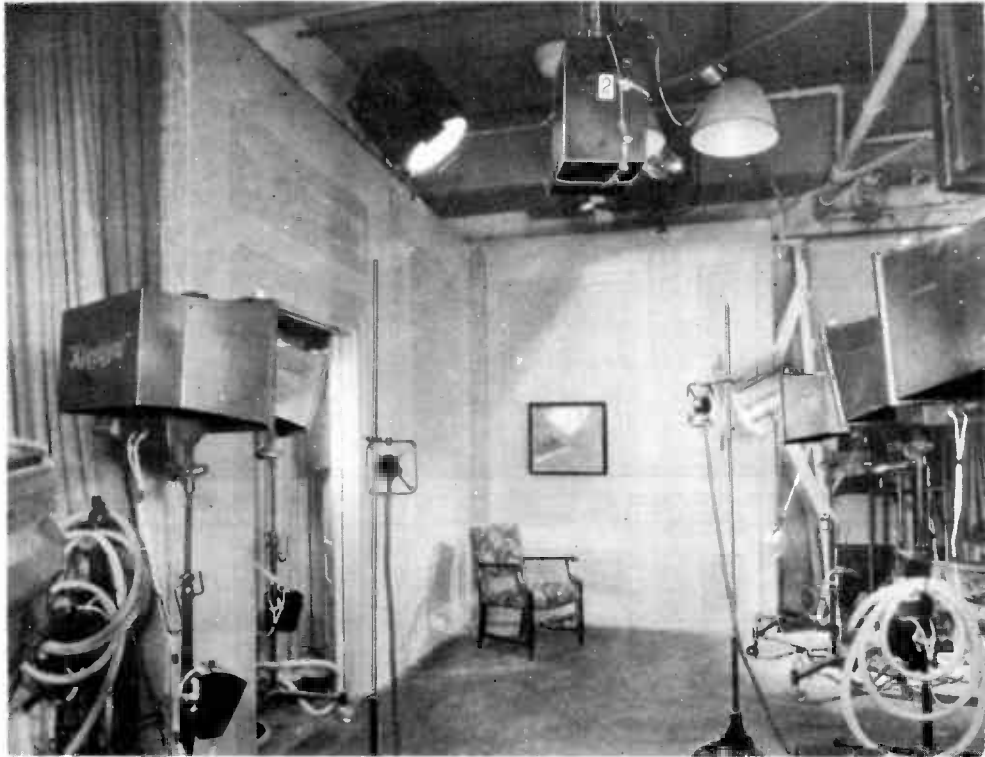

*The lighting arrangements are carefully planned for photographing this "corner set."*

## A Study of Lenses used in Sound-Pictures

VOL. 58, No. 7

Dewey Classification R 580

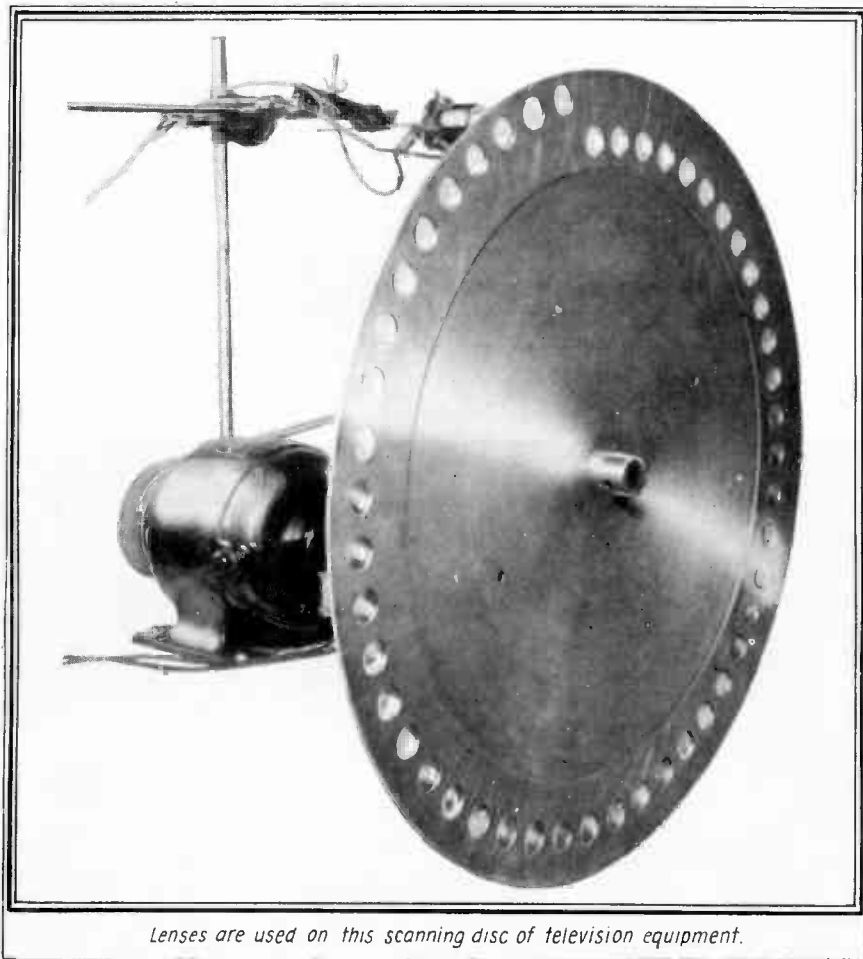

*Lenses are used on this scanning disc of television equipment.*

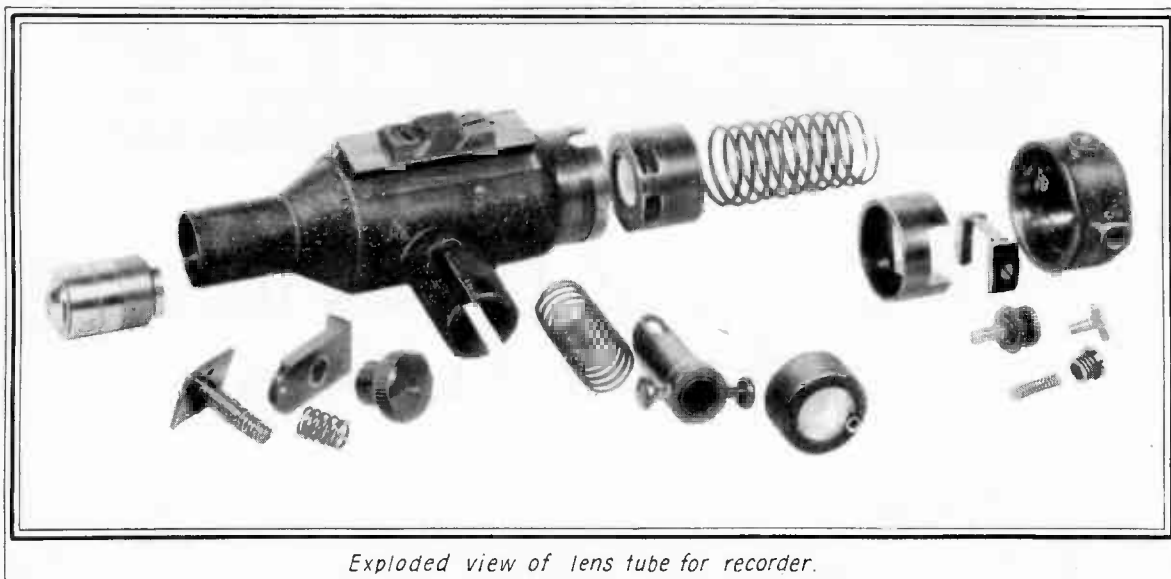

*Exploded view of lens tube for recorder.*

*America's Oldest Radio School*



LIGHT AND SIMPLE LENSES

VELOCITY OF LIGHT, Study of the action of light and lenses is quite necessary in a course on Sound Motion Pictures because light is used, not only in the projection of the picture on the screen but also in the recording and reproduction of sound by means of the sound-on-film system. Also, a knowledge of lenses and their function is essential because of their extensive use in sound-on-film recording and reproduction, which is rapidly replacing the sound-on-disc method.

Years ago, before the time of Roemer the scientist, it was thought that light travelled instantly from place to place because at that time there was no method known by which the speed of light might be estimated. One of the first steps toward the measurement of light speed was taken by Roemer in the year 1675 when he made certain observations and deductions, from which he concluded that light travelled about 186,000 miles per second.

Figure 1 illustrates how he made use of the movements of heavenly bodies to determine the speed of light. "S" is the sun around which our Earth "E" or "E'" revolves once a year. Its path is shown by the circle around the sun. "J" and "J'" represent the positions taken by the planet Jupiter which revolves around both Earth and Sun in a larger path or "orbit." "M" and "M'" are the positions of a moon which circles around Jupiter about every 45 hours. The dark cones are shadows made by Earth and Jupiter whose lighted halves face the sun. Let us explain that "E," "J," and "M" show the relative positions of Earth, Jupiter, and its moon at one certain time, whereas "E'," "J'," and "M'" show the positions of these bodies six months later.

It is apparent that as the small moon "M" circles around Jupiter "J" it plunges into the shadow of Jupiter. This causes an "eclipse" of "M" and it will not be visible again from Earth until it comes out from the other side of the shadow. After observing a number of these eclipses Roemer found that the elapsed time between them was always the same. Therefore, he predicted the time that a certain eclipse would take place six months later when the Earth reached "E'." He found that it actually took place 16 minutes and 36 seconds, or 996 seconds later than he predicted. He concluded that the delay of 996

seconds was the time required for light to travel across the diameter of the Earth's circular path around the Sun, and since this distance was estimated to be 186,000,000 miles he divided this value by 996 seconds and thus found the velocity of light to be about 186,000 miles per second. Later methods used to determine the speed of light proved that Roemer's method gave an approximately correct result.

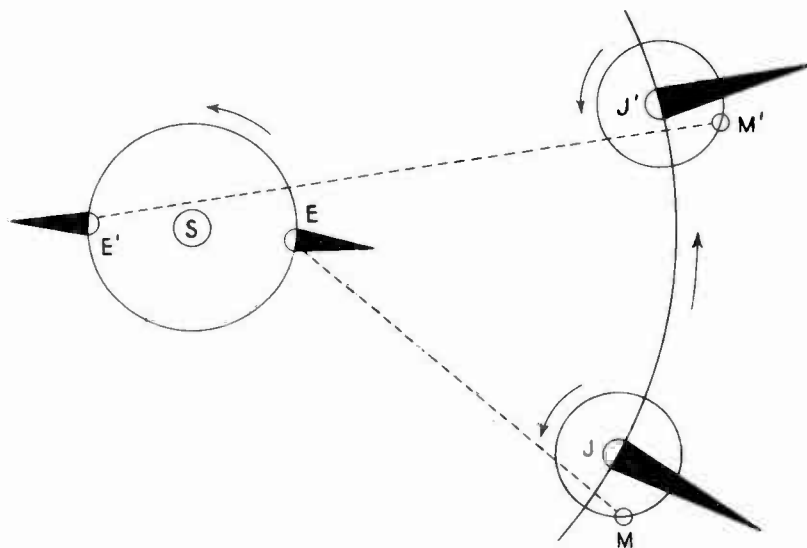

Figure 1

ABSORPTION — REFLECTION — TRANSMISSION OF LIGHT. Light, we know, will pass through many substances. It goes through certain substances without much loss while in other materials considerable light is lost as it passes through, and only a small portion of the rays which enter one side come out on the other. This is called "absorption."

When light rays strike a substance or material another action takes place which cuts down the amount of light which otherwise might pass through. This effect is called "reflection" and is best illustrated by mirrors which are capable of taking a large part of light rays which strike upon them and turning these rays in other directions. This effect is often noticed in our homes where a ray of sunlight is reflected by means of a mirror and we see the sun spot on the wall or ceiling. We may say then, that when light strikes any material part of it is reflected, part absorbed, and part goes through. It may seem that the last condition mentioned does not exist with every material, yet it is a fact that light has power to enter even metals to a certain depth. For instance, if light is allowed to strike on a very thin sheet of iron it can readily be seen from the other side, which demonstrates that some of the light actually passes through the metal.

Figure 2 shows the three conditions mentioned above when light strikes a piece of plate glass. "A" is the light ray which strikes plate glass "B." In our study of light and lenses, we use the ex-

pression "incident to" instead of saying the light ray strikes the glass. A part of the light is reflected in the direction shown by the dotted line "C." Another part of the original light ray is absorbed by the glass at "E." The remaining part of the ray passes out on the other side of the glass as at "D." Observe that lines "A" and "D" are parallel but slightly displaced from the position they would normally take if they formed a continuous straight line. The reason for this displacement will be taken up under "refraction."

We have said that all materials act on a ray of light in all three ways at the same time, that is, we have reflection "C," absorption "E," and transmission "D" taking place at all times. Materials, therefore, are classed according to which action takes place in the greatest amount. To explain, suppose we coat the under side of plate glass "B" with silver, it will reflect by far the greater proportion of the "incident" ray "A" and the glass will be classed as a reflector of light. However, if a piece of "dark" material such as black velvet is substituted for the glass then the greater proportion of the light striking upon it will be absorbed. Thus, black velvet may be classed as a good absorber of light. Any clear substance, such as glass, allows light to pass through without much loss and in this case it is classed as a transmitter of light.

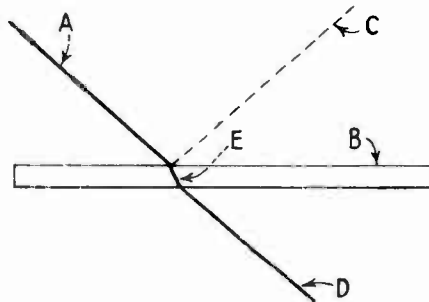

Figure 2

If a material allows no light to pass through, it is called "opaque;" if it allows light to pass through but so scatters or "diffuses" the rays that an object cannot be seen through it, the glass is said to be "translucent;" and if the glass allows light to pass through without diffusion so that objects can be seen clearly through it, it is "transparent." For example, the fire shutter on a motion picture projector is "opaque" and therefore when it drops down over the aperture it cuts off all light from the arc to the film. Of course, it also cuts off the heat rays which is its main function. A piece of oiled paper and ground glass are both translucent because they allow a certain amount of light to pass through although an object cannot be seen clearly when looking through either of these materials. Glass, water, and air are examples of transparent substances for they not only transmit light, but objects can be seen clearly through them.

In sound picture work use is made of the reflector principle as explained under the subject of lamphouses. Glass is used to gather

and transmit light by means of the condenser lens, which is located in the lamphouse. The image we see on the screen in a theatre is reflected to our eyes by the reflecting power of the screen, although in some cases a translucent screen is used. Examples of the use of translucent screens are to be found in the theatres in Europe where the motion picture projector is placed on the opposite side of the screen from the audience, or back-stage, the same feature being used by the Trans-Lux theatres in America. Enough of the light passes through the translucent screen to produce a satisfactory picture before the audience. Other examples of translucent screens are the so-called "daylight projectors" that one sees in store windows which are used for advertising purposes.

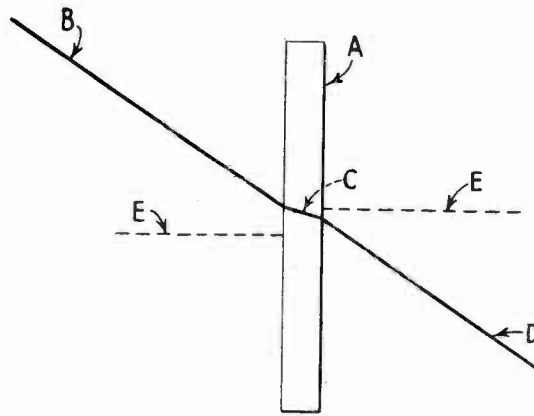

Figure 3

Speed of Light varies for Different Mediums. The velocity at which light is said to travel, or approximately 186,000 miles per second, is considered to hold good only for the medium of air or space through which it passes. If light passes through a medium or material which is denser than air or space medium its velocity will be decreased. In this respect light is similar to a bullet for example which will travel faster through air than through water, because water is approximately one-third more dense than air, or stated the other way around, air is about three-quarters as dense as water. The densities of various materials are as follows, air being taken as unity, or 1.00.

Water	1.33	Crown Glass	1.53
Alcohol	1.36	Flint Glass	1.67
Turpentine	1.47	Diamond	2.47

It will be seen from this chart that a diamond is almost twice as dense as water and considerably more dense than glass.

REFRACTION. One rule to remember is that light rays entering a dense material from a lighter one will be slowed down by the denser medium. This fact accounts for the action of a light ray when it strikes a medium of different density from that through which it has been travelling, as for instance, when it enters glass after travel-

ling through air. If it enters the second medium at an angle to its surface the light ray will be bent out of its former straight course and will follow a new straight course upon leaving it. "A" denotes the glass, "B" the entering ray, "C" the course of the light through the glass, "D" the ray after leaving the glass, while the dotted line "E," called the "normal" of the surface is an imaginary line drawn perpendicular to the surface of the glass. Since both faces or surfaces of the sheet of glass are parallel then "E" is normal or perpendicular to both surfaces. This is shown in the sketch in Figure 3.

It will be seen from this sketch that the incident ray of light "B" is bent upward as it enters the glass thus tending to go more in the plane or direction of the normal "E." This illustrates a law of optics which states that a ray of light in passing from a rare to a more dense medium is bent or "refracted toward the normal." The course of the ray is straight in the new medium, which is glass in this case, but upon leaving the glass the ray is bent once again, this time in a downward course as shown by "D." The latter condition indicating that the new direction of the ray is away from the normal demonstrates the truth of another law of optics, namely, a ray of light going from a dense to a rarer medium is "refracted away from the normal".

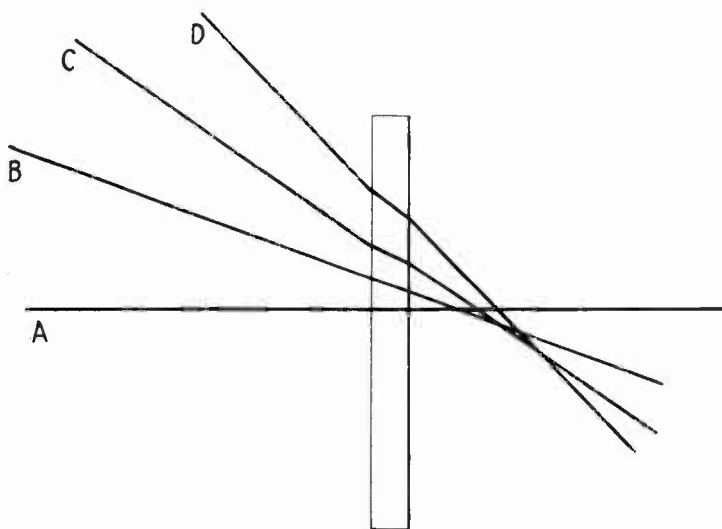

Figure 4

The course of the incident ray "B" is parallel with the course of the emergent (taken from the word "emerge" meaning "come out") ray showing that there was the same amount of refraction or bending of the ray when it left the glass as there was when it entered. This refraction of light takes place only if the ray enters the new medium at an angle to its surface. However, if the ray comes from such a direction that it enters the glass perpendicularly or on the line of the normal then no refraction takes place and its course would be as shown by "A" in Figure 4. The greater the angle of incidence (angle between incident ray and normal) at which the ray enters the new medium the greater will be the refraction. This is demonstrated by rays "B," "C," and "D," where a greater refraction takes place on entering and leaving the plate glass.

REFRACTION IN PRISMS. In leading up to a study of the effect of a lens on light rays we next come to a consideration of the effect of a prism of glass on light refraction. Figure 5 is an edge view of a prism "A" (a prism being a solid, in this case a column of glass, whose bases are equal and parallel and whose faces are parallelograms) with a light ray incident upon its surface, as at "B", from a source of light "C". Here again we have the principle of a light ray which upon entering a denser medium at an angle is refracted or bent toward the normal of the surface of the new medium, the normal being designated by the dotted line "D" which is perpendicular or at right angles to the left surface of prism "A". The refracted ray "E" is shown passing through the glass in a straight line to the right surface of the prism, where it is again bent or refracted, but this time away from the normal "F" of the new surface, taking a downward course "G".

The action of the light ray from the source "C" to the point "H" has followed each law of optics thus far explained. When the light ray entered the glass prism (a dense medium) from the air (a lighter medium) it was refracted toward the normal "D" of the left surface of the prism and as it left the denser medium, glass, and entered the lighter medium, air, it was bent away from the normal "F" of the right surface.

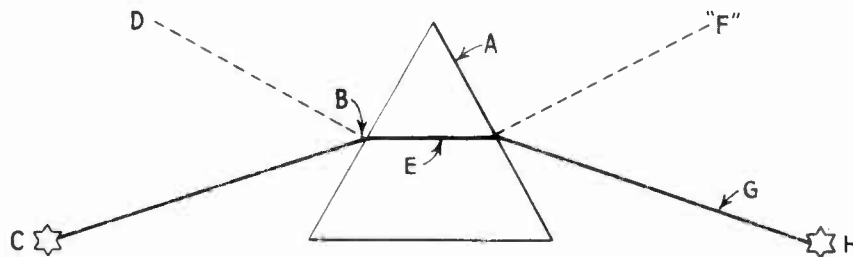

Figure 5

REFRACTION IN A CONVEX LENS. Suppose, this time we place another prism like the one in Figure 5, with its base or broad part up against the base of the first prism. We will then have an arrangement as shown in Figure 6. The appearance of the prisms is very much like the edge view of the double condenser lens used in a lamphouse. It will be seen that rays "A" and "B" both starting out from the same source of light "C" each arrive at the same point "D" after having been refracted by prisms "E" and "F." In this sketch "E" and "F" represent an edgewise view of a lens, like the lens in a camera for instance, that would appear round if it were viewed from the front or back. In this illustration only two rays of light are used to simplify the explanation but it should be realized, of course, that the source of light "C" sends out millions of such rays which enter the lens at every point on its surface and these are refracted in the same way as rays "A" and "B." This causes each point of light leaving source "C" to be gathered together again at point "D" by the action of the lens, thus producing an "image."



We know that if the source of light were a candle flame for example, the image also would take the shape of a candle flame when brought to a "focus" on a screen. Refer to Figure 6 at the location "D" which marks the point where the image is brought to a "focus." This point is called the "focal plane" of the lens because all the rays of light which left the plane of source "C" are brought to a focus in such relation to each other that a true image of the source is formed at the focal plane or "D" in a reversed position, that is to say, the image is upside down and with the left side of the source of light occupying the right side of the image and vice versa.

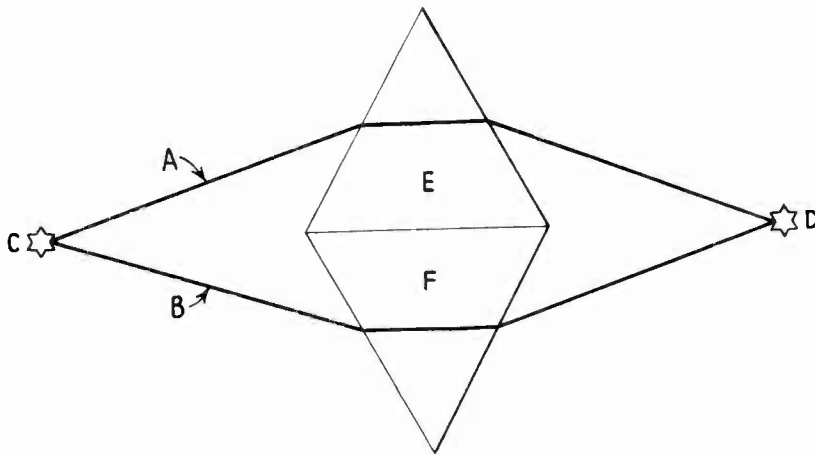

Figure 6

It can be seen from Figure 7, that the focal plane of the arrangement shown in Figure 6 can only be in one position for if (refer to Figure 7) the screen is placed at the focal plane "D" where the light rays originating at "C" are brought together, a true image of "C" will be obtained. Then if the screen be moved to either "G" or "H" the image will be out of focus because the points of light leaving the object "C" will not be brought together in proper relation but will be spread out over a greater surface as marked by X, Y, or X', Y' and consequently the image will be blurred or indistinct. In this drawing outlines of the two prisms are shown in dotted lines, but in Figure 6 these lines are filled in to form an edge view of a true lens.

LIGHT WAVES — WAVE FRONT. The action of light as it enters a dense medium will be our next topic. Light waves, like water waves or air waves, have a wave front. The wave front of a water wave is circular in form as shown in Figure 8. This is the effect that is seen when a stone is thrown into a pond or other body of water, and consists of rings or circles of disturbed water which are more often referred to as "waves" or "ripples." This disturbance starts at the point where the stone strikes the water and expands rapidly into circles which become wider and wider as they move outward until finally the resistance or inertia of the water reduces the amplitudes of the waves until they die down and are no longer visible. All of the circles as they travel outward are called the wave front, likewise each small segment of any individual circle is also known as the wave front of that

part of the wave, as for instance that portion between lines "A" and "B." A moment after the stone touched the water that part marked "ab" on the sketch was a segment of the wave front; but a short time later we find "a'b'" is the new position of the same segment of the wave front; and finally the wave front arrives at "A-B" thus indicating the movement is always progressing outward toward "X." From this explanation it is apparent that as section "a b" moves out from the center of the disturbance the direction of travel of the wave front, or any part of it is at right angles to the wave front itself.

Light waves also follow this rule, and therefore the wave front of a ray of light travels in a direction at right angles to the plane of the wave front. There is a difference, however, between water waves and light waves in that water waves move over the surface of the water as expanding circles, whereas light waves travel in the shape of a sphere or ball in all directions from their source. Now, since it is a law of light that rays always travel at right angles to or perpendicular to their wave front, then it must be true that if the direction of the wave front is changed, the rays will also change their direction of travel.

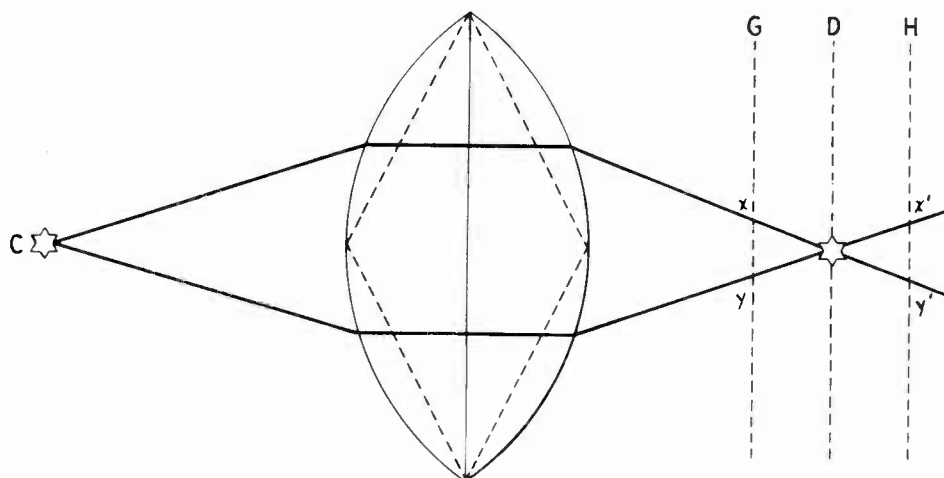

Figure 7

This change in the direction of a wave front is exactly what happens when light enters a new medium, as shown in Figure 9 where a wave front of light "A" travelling in the direction "B" strikes a body of water "C" at an angle. The lines 1, 2, 3, 4, 5, and 6 denote sections of the wave front and are used merely to allow us to give a clearer explanation of the sketch. Assuming that air is the medium through which the light is travelling before it reaches the surface of the water, then that part above the line marked "C" represents air while the part below the line represents water.

Any section comprising the wave front of light must always take the shape of a curve because all sources of light send out waves in spherical form. Of course, if a source of light is many miles away, as for instance the sun, then by the time the wave has expanded sufficiently to reach the people on Earth the curvature of the wave at this great distance is so slight that it may be considered to be a

straight line, or "plane wave" as shown by "A" in Figure 9. Wave "A" travels at the same velocity along its entire front from 1 to 6 so long as the medium through which it passes enters the water, however, the part marked 1 of the front in striking the denser medium first is slowed down for the reason as already explained that the

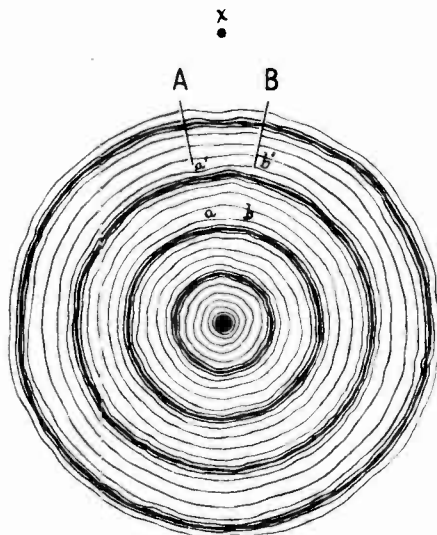

Figure 8

velocity of light is less through a dense medium like water than through a lighter medium like air. Although part 1 of the wave front is shown travelling in the water, part 2 is still in air but about to enter the water, while parts 3, 4, 5 and 6 of the front are considerably further away from the surface of the water and are trav-

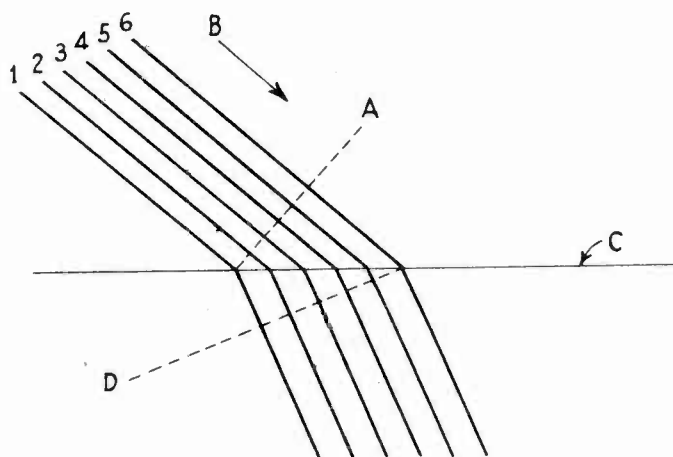

Figure 9

elling at the speed of light in air. It is evident that the end of the wave front indicated by number 1 is held back by the density of

the water while the wave end toward number 6 travels at the greater speed of light in air. This difference in velocity will cause the wave front "A" to swing toward the horizontal until the time comes when the number 6 part of the front has just entered the water. The wave front "A" will have reached the position shown by the dotted line "D" which is the new front of the wave as it travels through the water. Inasmuch as the direction of travel of light is always perpendicular or at right angles to its wave front, and the wave front in the water is different from what it was in air, it follows that the direction of travel or "propagation" changes to suit the new wave front, and the light travels in a new direction through the water.

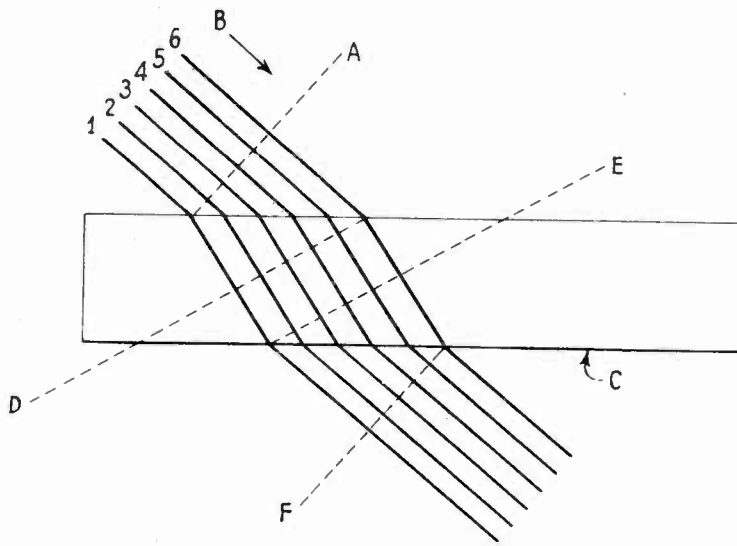

Figure 10

Glass and water both influence light rays in the same way, the difference being that the effect caused by glass is more pronounced because of its greater density when compared to water. By substituting a thick sheet of glass for the body of water in Figure 10, the same action is seen to take place as shown in Figure 9, but in Figure 10 we have also indicated how the light rays again change their direction when they leave the dense medium, glass, and enter the lighter medium, air. Referring to Figure 10 it will be seen that the wave front entering glass "C" was changed toward the horizontal until it reached the new position "D", much the same as it changed when entering the water, as indicated in Figure 9. The wave front "D" in Figure 10 continues in the same direction until part 1 of the front reaches the air underneath, whereupon it immediately increases its velocity to equal that of light rays in air, while at the same time that part of the wave from 2 to 6 is still passing through glass, and naturally the velocity of the rays through the latter or denser medium is much slower. This gives part 1 of the wave front a chance to catch up with part 6 which is still moving in the glass, until the time comes when part 6 has also reached the air, then part 1 will have advanced to the position shown at "F" which denotes the new wave front as it travels in air. Observe that wave front "F" upon leaving the glass is parallel to wave front "A," and so we learn that while

light travels in the same direction as it did before it entered the glass, its path is slightly displaced from its original path. Also notice that when the two surfaces of the glass are parallel the light rays are refracted the same amount upon leaving as upon entering the glass and therefore although the rays are moving in parallel directions on both sides of the glass they are slightly displaced.

We previously mentioned that if rays of light entered a "double convex" lens, as the lens in Figure 7 is called, the rays would "converge" or come together at some point on the other side of the lens. It was also stated that the greater the angle from the normal at which the incident ray enters the lens, or the greater the angle of incidence, the greater will be the refraction or bending of the ray.

From the foregoing facts we know that the normal of a plane surface, such as a piece of plate glass, is at right angles to its surface, but in the case of a curved surface, as for instance the surface of a condenser or convex lens, a different procedure must be followed to locate the normal as will now be explained.

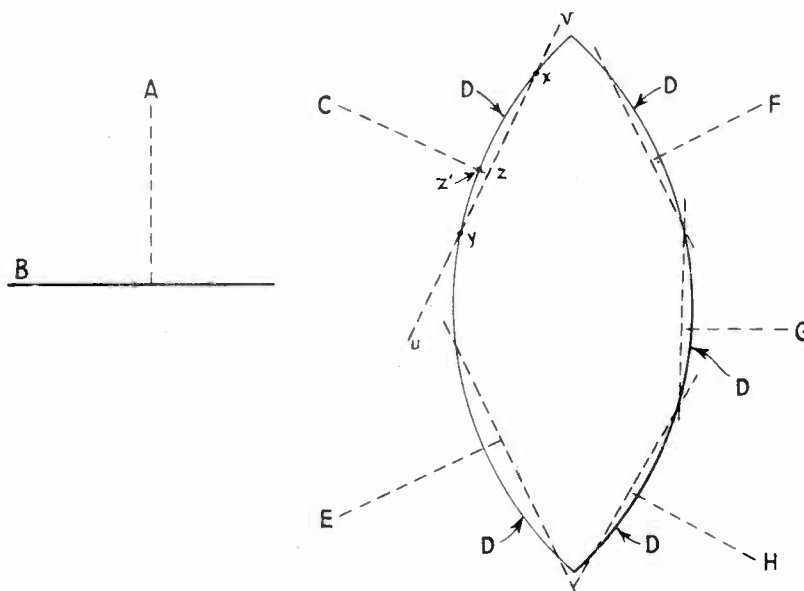

Figure 11

FOCAL LENGTH OF CONVEX LENS. Figure 11 shows the normal "A" to a plane straight surface "B." Dotted lines "C," "E," "F," "G," and "H" are also normals of curved surfaces "D" at various places on a double convex lens. The normal to a curved surface is found as follows: Draw a straight line cutting the curved edge of the lens in two places as at "U" and "V" in Figure 11. Locate point "Z" on this line half way between the two points where the straight line cuts the curved edge "D." In the drawing "X" and "Y" are the points where "U" and "V" cut the curved line "D," and "Z" is located half way between "X" and "Y." The line "CZ" is then drawn perpendicular to "UV" and is normal to the edge "D" at "Z."

From this illustration it can be seen that for a given convex lens the thicker it is at its center when compared with its edge the greater will be the angle (angle of incidence) at which light strikes its curved surface and therefore the more it will be refracted. If it is refracted more it will come to a focus closer to the lens on the other side, and thus the lens is said to have a short focal length. The focal length of any convex lens is the distance between the center of the lens itself, and the point where parallel rays of light, entering the lens, are brought to a focus. Figure 12 shows this difference clearly where "A" is a thin lens and "B" a thick one, and although parallel rays of light from a distant source enter each lens alike, yet they are brought to a focus at different distances from the respective lenses. It can readily be seen that the focal length "C" of the thin lens "A" is twice as great as the focal length "D" of the thick lens "B."

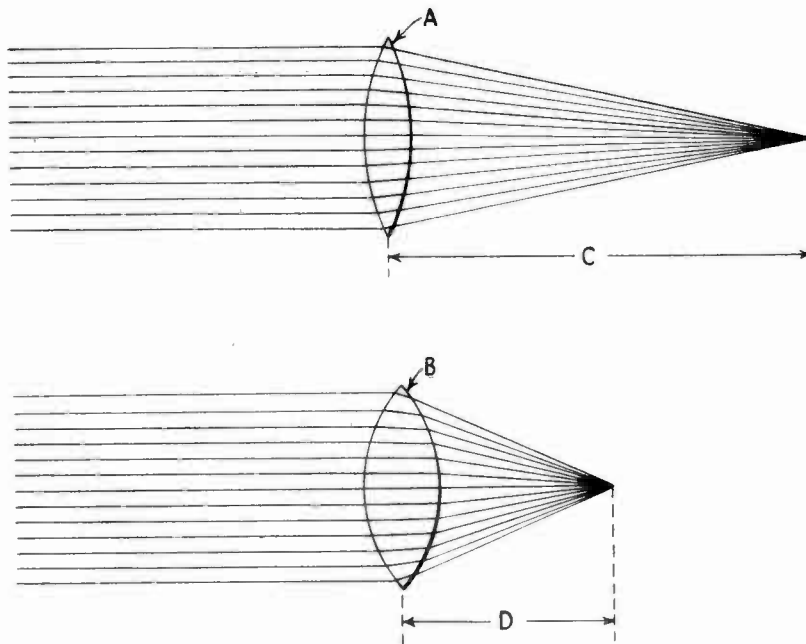

Figure 12

If you wish to find the approximate focal length of any convex lens it is only necessary to hold the lens up so that rays of light from any distant object, such as a building for example, will shine through it to a piece of white paper. When the image of the object is distinct and clear on the paper it is properly focused.

By measuring the distance from the center line of the lens to the paper you will get a close estimate of the focal length of that particular lens. Bear in mind, however, if the source of light is very near, or only a few inches or feet away this method will not prove accurate for the rays of light in this case will not be parallel. In fact, when the source of light is near the lens the focal point will change noticeably as the source is moved closer to, or farther away from the lens. Let us repeat that the focal point is the point where all rays of light passing through a convex lens are brought together or to a focus.

This action can best be explained by using the wave front method of demonstration as shown in Figure 13, in which "L" is a convex lens, "S" a light source, and "F" the focal point of the lens where an image of the source "S" is formed by the converging wave front of light rays indicated at the right of the lens. At the left of the lens, or between the light source "S" and the lens itself, can be seen the curved lines of the diverging wave front of the rays from the source. The wave front is, of course, circular in form, as shown near the source "S" but only that portion of the front that strikes the lens is of interest in this case. The wave front between the source and the lens is said to be diverging, because unless it is changed in form so that it curves in the opposite direction, the rays which left the source will never come together again to form an image of the source. The convex lens is able to change the form of the wave front, however, by holding back the middle of the wave as it passes through the dense glass medium. This allows the ends to catch up with the middle and then to speed ahead so that as the wave undergoes a change and as it passes out of the lens on the opposite side it becomes a converging wave which brings all the rays to a focus at "F."

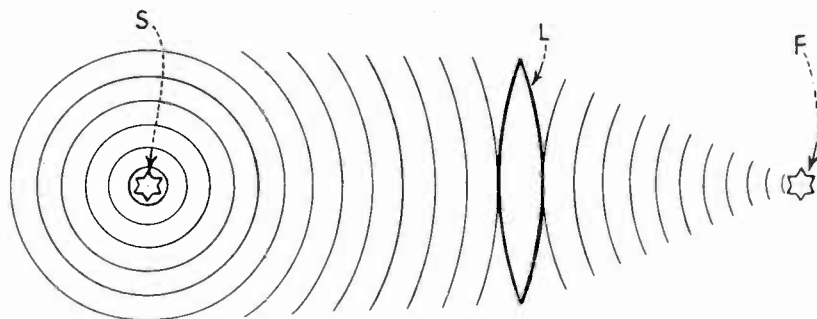

Figure 13

It should now be easy to understand why a thick lens has a shorter focal length than a thin one simply because its thicker center holds the middle of a wave back even more than a thin lens and thus allows the ends of the wave to get further ahead. Thus, a wave front of sharp curvature (short radius) is produced. With a short radius the wave front converges to a point more quickly than it would if it came from a thinner lens and so produces the image closer to the lens. This demonstrates that a convex lens always slows up the middle of a wave and the thicker the lens with relation to its edges the more it holds back the middle of the wave and the more the ends are able to catch up, as it were.

Suppose this time we move light source "S" close to the lens, as in Figure 14. This is actually what we do at times in order to focus the light of the arc to a proper spot on the aperture of the motion picture head. Moving the light source is also necessary when focusing the light beam on the sound track of the film in the sound head of a sound motion picture projector. Referring to Figure 14, we find that the wave front is more curved now when it strikes the lens because it is closer to the source and as we explained in the case of the light from the sun the farther a wave extends from its source

the less curved it becomes, until at very great distances the wave front is practically in the same plane and the rays are travelling in parallel lines.

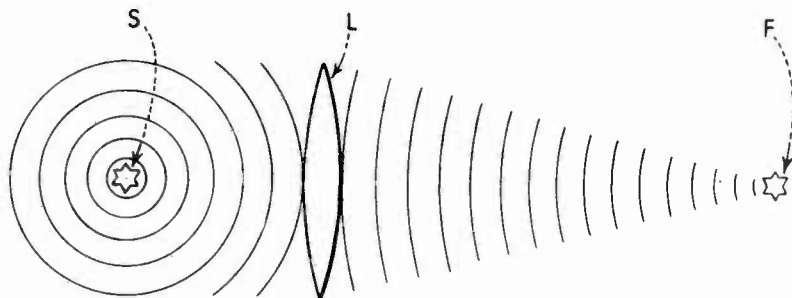

Figure 14

We found from a study of Figure 13 that the lens held back the middle of the wave to such a degree that not only was it straightened out but it actually reversed in form, so that where the middle of the wave formerly travelled ahead of the ends, the ends travel ahead of the middle after passing through the lens. This action changed the wave front from a "diverging" form on the left of the lens to a

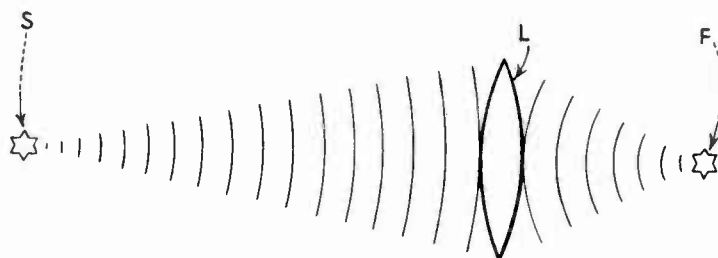

Figure 15

"converging" form on the right side, and the light came to a focus at "F." In both Figures 14 and 15 the lenses are the same and therefore each holds back the middle of a wave by exactly the same amount. In the case of Figure 14, however, the wave striking the lens is more curved, and even after the lens holds back the middle of it by the same amount as for the wave in Figure 13, it will be seen that in Figure 14 the ends are not as far ahead of the middle when the wave comes out of the lens as is the case in Figure 13. This means that the wave leaving the lens in Figure 14 is less curved than the wave leaving the lens in Figure 13 and, furthermore, the center of its curvature, or focal point, as in Figure 14, is farther away from the lens than it was under the conditions pictured in Figure 13.

If the source of light were moved farther away from the lens in either Figures 13 or 14 the opposite condition would be brought about, or one where the image would be focused at a point nearer the lens than in either of the previous cases. This condition, as shown in Figure 15, is due first to the fact that waves which strike the lens



from a more distant source are "flatter" or less curved, and second, because the lens in slowing up the middle of such a wave by the same amount as in the other two cases puts a sharper curve in the flatter wave that passes through it. All of this results in bringing the image of the source to a focus nearer the lens.

To demonstrate another point suppose we turn Figure 15 upside down and place it over Figure 14. We have almost an exact copy of Figure 14 which shows that if a source of light, as for instance "S" in Figure 15, is focused to an image at "F" through a lens "L" and the source of light is then moved to the point "F," the image will be focused at the place where the source was formerly located, or at "S." In other words, "S" and "F" are interchangeable for if the source of light be located at either place the image will be brought to a focus at the other. It is apparent from this fact that the mechanism of a lamphouse, or sound head used in sound motion pictures, which permits the source of light to be moved closer to, or farther away from the lens, enables the rays of light from the source to be brought to a focus at the point desired, whether in the aperture in the picture head in one case, or in the sound head in the other. Of course, moving the lens while the source of light remains fixed would accomplish the same result but in sound picture work it is found more practical to move the light source and permit the lens to remain fixed.

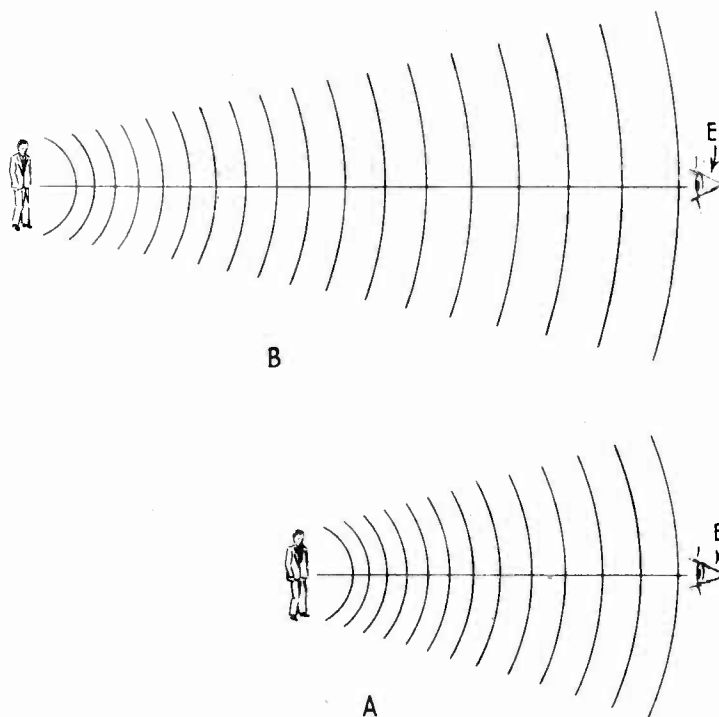

Figure 16

HOW THE EYE JUDGES DISTANCE. When a small section of light wave strikes the eye, the eye "sees" to the center of the curvature of the wave, that is, it sees the object as being at the center of a circle whose circumference is a continuation of the small section that enters the eye.

Figure 16 illustrates this idea, "A" showing waves from a nearby object entering the eye and "B" waves from an object farther away. The waves that reach the eye "E" in sketch "A" have considerable curvature to them as you will observe and since the small section of the wave that enters the eye causes it to see to the center of a circle of which it is a part, the object will appear large because the center of the circle is near the eye. On the other hand in sketch "B" the waves reaching "E" are much flatter and have less curvature and the eye "seeing" to the center of this larger circle registers the object as being smaller.

Many persons can judge with a fair degree of accuracy how far away a certain object might be through knowing its comparative size with another object which is close by. For instance, experience has taught us that most men are about alike in general size and, therefore in a case where two men are standing some distance apart instead of believing what our eyes tell us, that the man nearest us is larger, we know that the man nearest only seems to be larger. For more accurate judging of distance we call upon both eyes to work together to produce what is known as binocular vision wherein each eye sees the object at a slightly different angle and by this means we appreciate the depth of a scene and object. We study this faculty of the eyes in the subject dealing with stereoscopic or third dimension motion pictures.

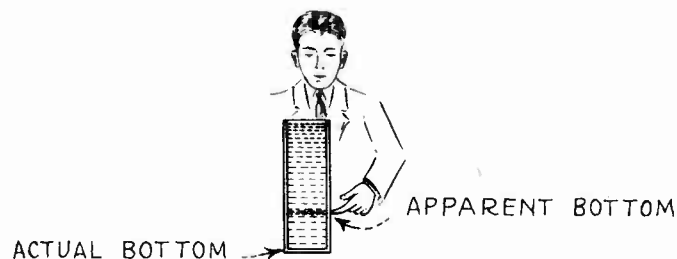

Figure 17

If the light wave which leaves the object is changed in form by passing through a different medium before it reaches the eye, the object will seem to be at the center of the new curvature into which the wave was changed by its passage through the new medium. This is best demonstrated by looking at an object in water and then trying to touch the object. It will be found to your surprise that the object is down a greater depth than it appears to be, that is, your eye tells you the object is located higher in the water than its actual position. Figure 17 shows where the bottom of a container of water appears to be when viewed from above and no doubt you would actually touch this spot if told to put your finger on the place where the side and the bottom of the container meet. Observe that the point where the bottom appears to be is about one-quarter of the total height of the water above the actual bottom.

Again using the wave front method of demonstration, refer to Figure 18 where "A" is an object under water, "W" is the surface of the water, "E" is the eye looking directly down into the water, and "E'" is the eye looking into the water at an angle to its surface. The

wave front of light from source "A" passes upward becoming less curved as it gets further away from the source and if it continued travelling in water when it reached the point marked in the drawing it would have the shape or curvature represented by the dotted line. The middle part of the wave, however, speeds up as soon as it leaves the dense medium water and enters the lighter medium air, so that while the ends of the wave may still be travelling in water at this moment, the middle gets ahead of the ends and bulges the wave upward thus producing a wave front of greater curvature.

The newly-formed wave front now proceeds upward in air until a section of it enters the eye. The eye in receiving a wave of this curvature, sees to the center of the curve, and since the center is at "B" instead of "A" the object appears to be at "B" when it is actually at "A." To the eye at "E" the apparent object "B" is in a line with the actual object "A" but when the eye views the object from point "E'" the apparent object "B" appears above the actual object "A." It is quite evident that if object "A" were a fish in the water and a man stands at "E'" and tries to spear it, he should aim at a point below where he sees the fish.

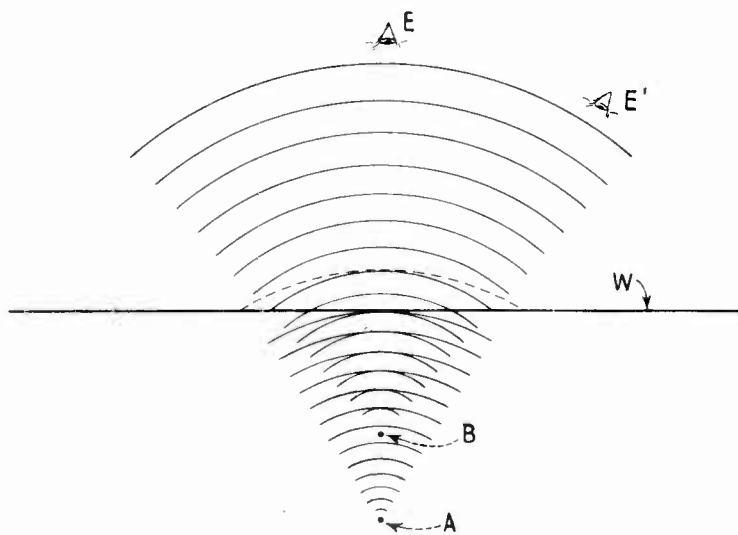

Figure 18

Thus, we see that all objects under water, when looked at from a point not in the water appear nearer than they actually are and this peculiar effect is attributed to the fact that the velocity of light is greater in air than in water.

Remembering from Figure 17, that the bottom of the container appeared to be located at a point about three-quarters the actual distance below the surface of the water we can reason that the velocity of light in water is about  $\frac{3}{4}$  that of light in air. If we assume the reverse of the situation shown in Figure 18 and consider that the eye is placed under water, then all objects outside of the water appear to be further away than they actually are. This can be demonstrated by drawing the wave front as coming from a source above and placing the

eye beneath the surface of the water. In this case, the curvature of the wave front will grow flatter or less curved when it strikes the water and the source will appear further away than its actual position.

CONCAVE LENS. The lens we have studied in the foregoing paragraphs is the convex lens. One type in use in lamphouses is the plano-convex lens, which is flat on one side and curved out on the other. Another type is the bi-convex or double-convex lens, which is rounded out on both sides and can be made from two plano-convex lenses with their flat or plane sides placed together. Another type of lens used in motion picture optical work is the concave lens.

A "convex" lens is always thicker at the center than at its edges, but a "concave" lens is just the reverse, or thinner at the center than at the edges. Figure 19 shows edgewise views of four types of lenses, "A" being a plano-convex, "B" a bi-convex or double-convex, "C" a plano-concave, and "D" a bi-concave or double-concave. The face or front view of each lens when viewed in this manner is similar and, of course, would appear like "E."

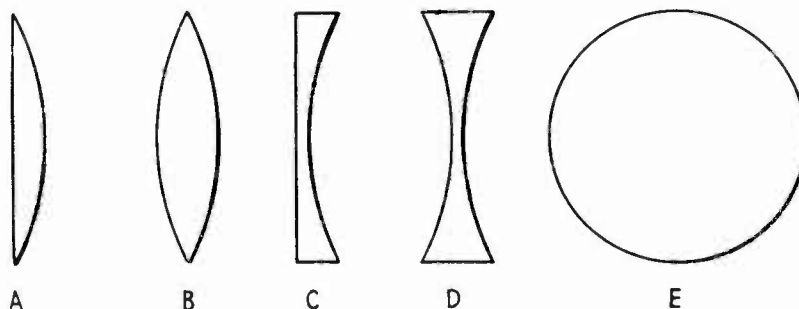

Figure 19

We found in our study of the convex lens that a cross section of such a lens could be divided into two sections each of which resembled a cross section of a prism as shown by the dotted lines in Figure 20. The dotted line "x" forms the base of both the upper and the lower triangular prisms, the points of such prisms being called the "apexes." As may be seen in "A" of Figure 20 one apex is located at the top of the upper prism and another at the bottom of the lower prism. Light rays in passing through these prisms are refracted toward the base or center line and are brought to a focus on the center line of the lens as shown in "B" of Figure 20. If we take a cross section of a double-concave lens and divide it in the middle we will have roughly two prisms somewhat like those obtained after dividing a convex lens cross section. However, in the case of the concave lens the two prisms, instead of having their bases together, will have their apexes together or point to point as shown in sketch "A" of Figure 21 where the top half is shown as a prism with the point or apex down, and the bottom half is shown as a prism with the apex up. Here it is seen that the "base" of the upper imaginary prism is at the top while the "base" of the lower imaginary prism is at the bottom. The "bases" of the imaginary prisms thus become the edges of the concave lens. Refer to "A" in Figure 21.

Light rays in passing through these prisms, according to the law of refraction, bend toward the "bases" or away from the center line. This law states that the rays bend toward normal on entering a denser

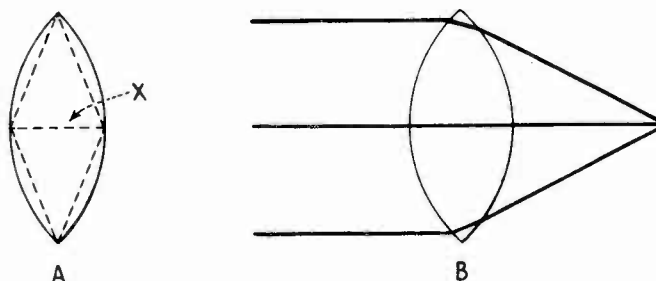

Figure 20

medium and away on entering a less dense medium. Since light rays entering a concave lens are not brought to a point on the opposite side, but are refracted away from the center, then no image of the source can be brought to a focus after the rays pass through the lens. In drawing "B" of Figure 21 the course of parallel rays of light from a distant source are shown as they pass through a concave lens.

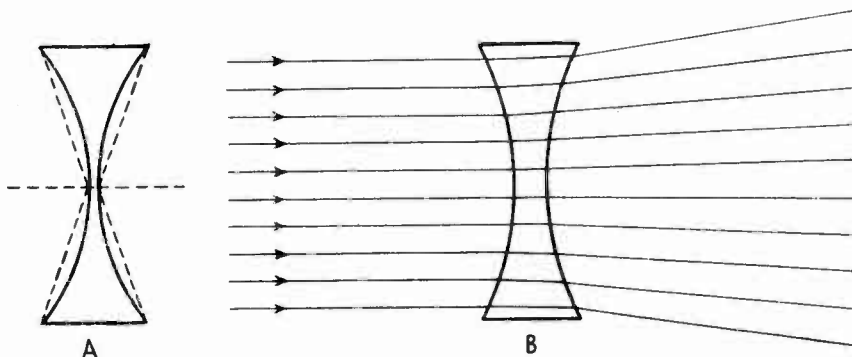

Figure 21

The action of a concave lens on light rays can be easily explained by again making use of the wave front method shown in Figure 22, where the circular wave front from a near source of light upon passing through a concave lens is changed in form, it being understood that in every case the front becomes more curved by its passage through the lens. Contrary to the action of a convex lens, the wave front cannot be reversed by a concave lens. Referring to Figure 22, the source of light "S" sends out a curved wave front which after passing through concave lens "L" is held back at the ends by the thicker glass at the edge of the lens. The ends being held back allow the middle, which is still travelling in air, to get even further ahead of the ends than before or previous to the time the wave front entered the lens.

This gives the wave front a greater curvature as it comes out of the lens and the eye "E" receives a section of the altered wave front. Source "S" appears to the eye to be at the point "F" or the center of curvature of the altered wave front, which is called the "focal point." It can be seen that while the focal point of a convex lens is on the opposite side of the lens from the source, in the case of a concave lens the focal point is on the same side as the source. Another big difference between these types of lenses is that the image formed at the focal point of a convex lens is an "actual" image, that is, all the rays of light striking the lens from the source are gathered or focused to a spot that can be seen on a screen, whereas the rays from a source that pass through a concave lens are "diverged" or spread, instead of being gathered and therefore cannot form an actual image on a screen. The image formed by a concave lens, as at "F" in Figure 22, is called a "virtual" image because it can be seen by the eye which receives a small section of the wave front and sees the image of the source at the center of this wave front.

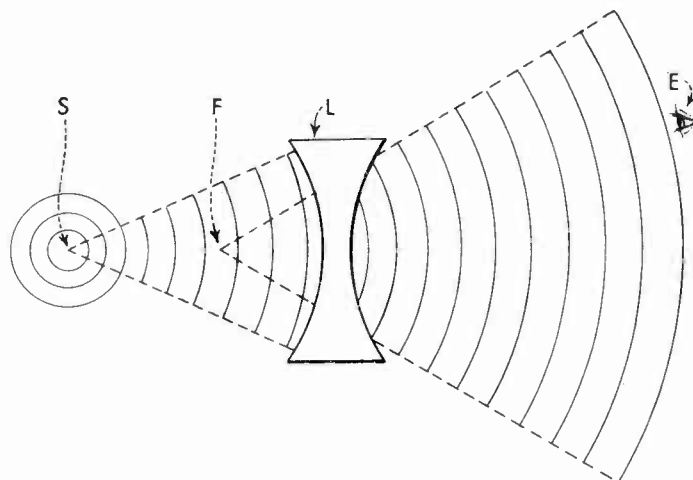

Figure 22

Moreover, using the wave front idea we see that if the source is moved closer to the lens the virtual image is formed closer to the lens and likewise if the source of light is moved further from the lens the image is formed further away from the lens. In every instance, however, the image is closer to the lens than the source of light. Quite the opposite effect takes place in the case of a convex lens because with this type the closer the source is to the lens, the further away will be the image formed and vice-versa. The focal length of a concave lens is the distance from the center of the lens to the point where the virtual image is formed, when the rays entering the lens are parallel.

This type of lens is used in sound motion picture apparatus for correcting troubles in lenses known as spherical aberration and chromatic aberration. Concave lenses are used with convex lenses where such corrections are necessary. These combination lenses are known as cor-

rected lenses and are used as follows: 1st, in the picture head of a projector to throw a true image on the screen; 2nd, in the optical system of the sound head, or the sound-on-film recorder, to project a true image of a slit of light on the sound track of the film; and 3rd, in the motion picture camera to form a true image of the scene being photographed on the sensitized film.

**TOTAL REFRACTION.** Another property of a prism known as "total refraction" is explained in the following paragraphs. By this term is meant that a prism has the power to take all the light it receives and turn it in a direction at right angles or 90 degrees to its original direction. Mirrors are also able to change the direction of travel of light waves but their efficiency is much lower than glass prisms in doing this because less light is lost in a prism by absorption. At first thought it seems strange that a piece of clear glass is able to turn a light ray to such an extent but a more detailed study of the refractive effect of water on light than is given in the early part of this lesson will show that the action is easy to understand. For this explanation refer to Figure 23, which shows the surface of a body of water "W" with rays of light "A," "B," "C," "D," and "E" coming from a source of light "S" under the water and striking the surface at different angles. Note that ray "A" leaves the

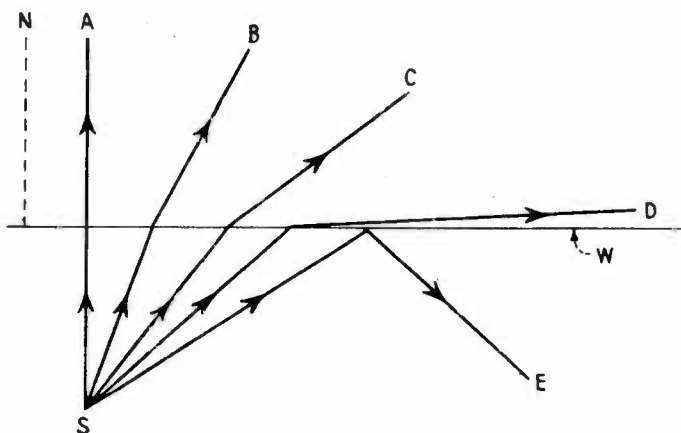

Figure 23

water along the line of the normal "N" and is therefore not refracted but continues on unchanged in direction into the new medium, which is air in this case. In obedience of the law that light passing from a dense to a lighter medium is bent away from the normal we find that ray "B" bends outward as shown. Another law of optics previously given states that the greater the angle of incidence the greater will be the angle of refraction; this law explains why rays "C" and "D" upon leaving the water at greater angles to the normal are refracted even more than ray "B." Ray "D" has been refracted to the extent that its course lies practically along the surface of the water. When the angle of incidence becomes greater, as in ray "E," the refraction is then so great that the ray does not leave the water at all but is bent back again and it is obvious no light from this ray enters the air. Glass, being a dense medium exhibits this characteristic, known as "total refraction," in a more pronounced manner than water.

The principle just explained is used commercially in binoculars as shown in Figure 24, and also in sound picture work where so-called periscopes are used for adjusting optical systems in recorders and

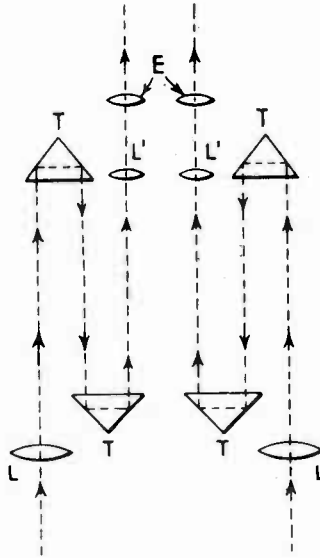

Figure 24.

sound heads as Figure 25 illustrates. In Figure 24 the light enters lenses "L" at one end of the binoculars and is totally refracted twice in each barrel by the glass prisms "T," after which the light enters the eye pieces "E" at the opposite end, which are held to the

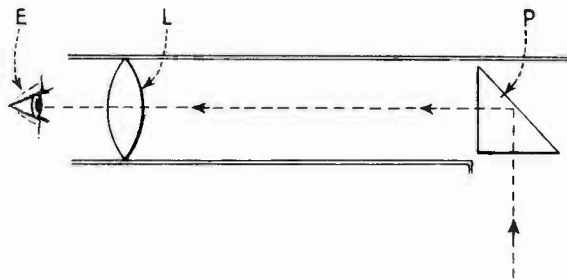

Figure 25

eyes when the instrument is in use. The main reason for using prisms is to provide a longer distance of light travel between lenses "L" where the light enters the instrument and lenses "L'" where the light enters the eyes. The magnifying power of a telescope or field glass is dependent to a large degree on this distance between lenses.



By the use of prisms, the same length of light travel can be obtained in comparatively short binoculars as in straight tubes or telescopes which are several times longer.

The "periscope" shown in Figure 25 makes use of a prism merely to take the beam of light from an "exciter" lamp and turn it at right angles, so that the sound service man may in effect see around a corner. Referring to the drawing, the light first enters the glass prism "P," next it is refracted at right angles through the tube of the periscope and then passes through lens "L" to the eye "E."

Another lesson dealing with combination lenses used in motion picture projectors, cameras, and sound-on-film recorders includes in addition the subject of mirrors and laws of reflection.

---

EXAMINATION QUESTIONS

1. Draw a bi-convex lens showing path of rays from a point source through the lens, to the focal plane.
2. Show by a sketch how the wave front of parallel rays is changed passing from air to water at an angle.
3. Has a convex lens with a comparatively thick center a longer or shorter focal length than a lens with a thinner center?
4. Draw a sketch of a double-concave lens showing path of light rays through it from a point source.
5. What kind of image does a convex lens form? A concave lens?
6. Show by the wave front method why moving the point source of light nearer the lens changes the location of the image.
7. How may you quickly determine the focal length of a convex lens?
8. What type of lens is used in the lamphouse of a projection machine?
9. Draw an edge view of a convex lens and a concave lens, showing in dotted outline how each can be roughly divided into two prisms.
10. How does the eye judge distance or comparative size?

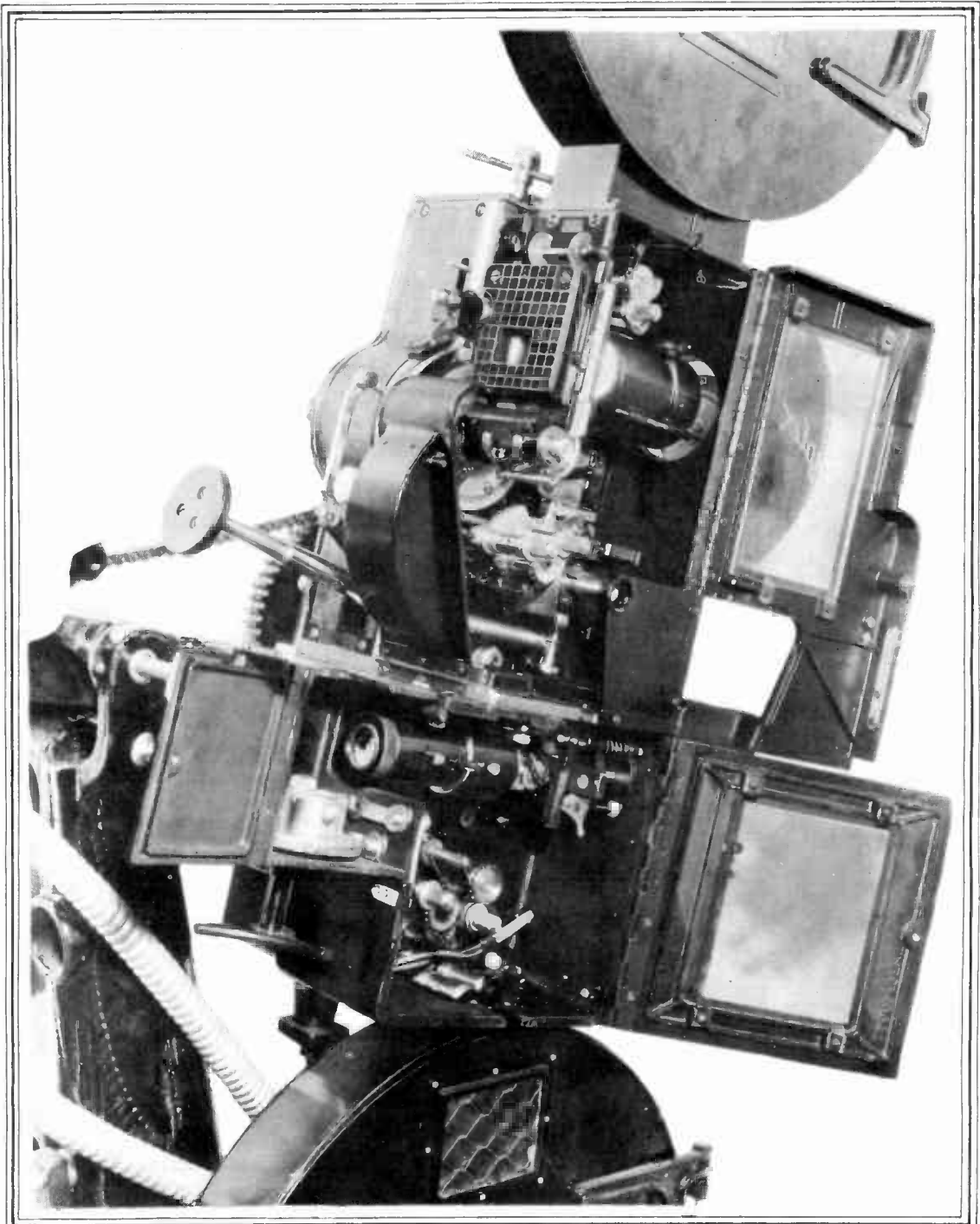

*Sound head compartment with door open showing lens tube.*

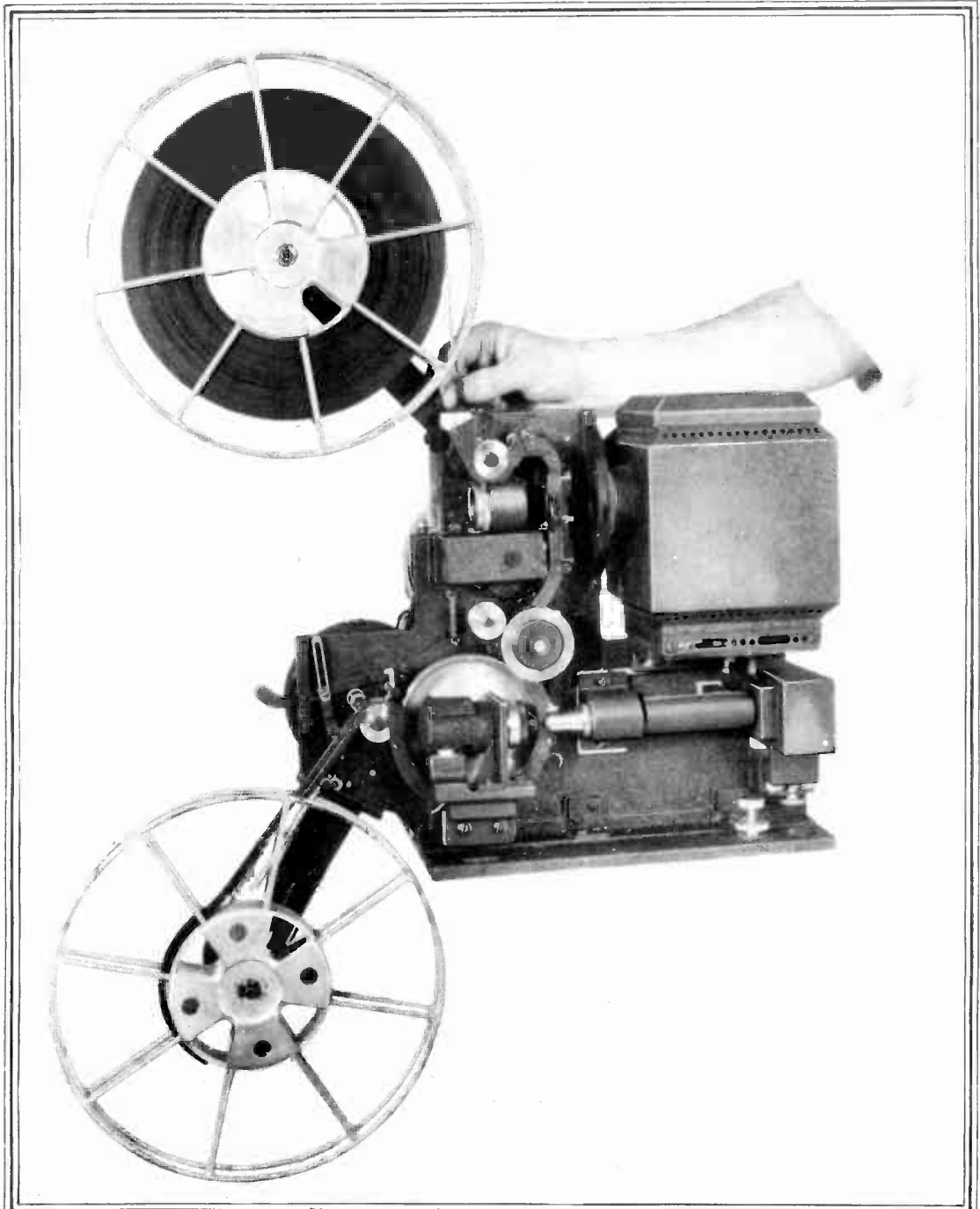

*A sound-picture projector for the home showing two lens tubes. The upper lens is for picture projection and the lower for sound reproduction.*



MADE  
IN  
U.S.A.

P.O. 1244

VOL. 58, No. 7