

America's Oldest Radio School

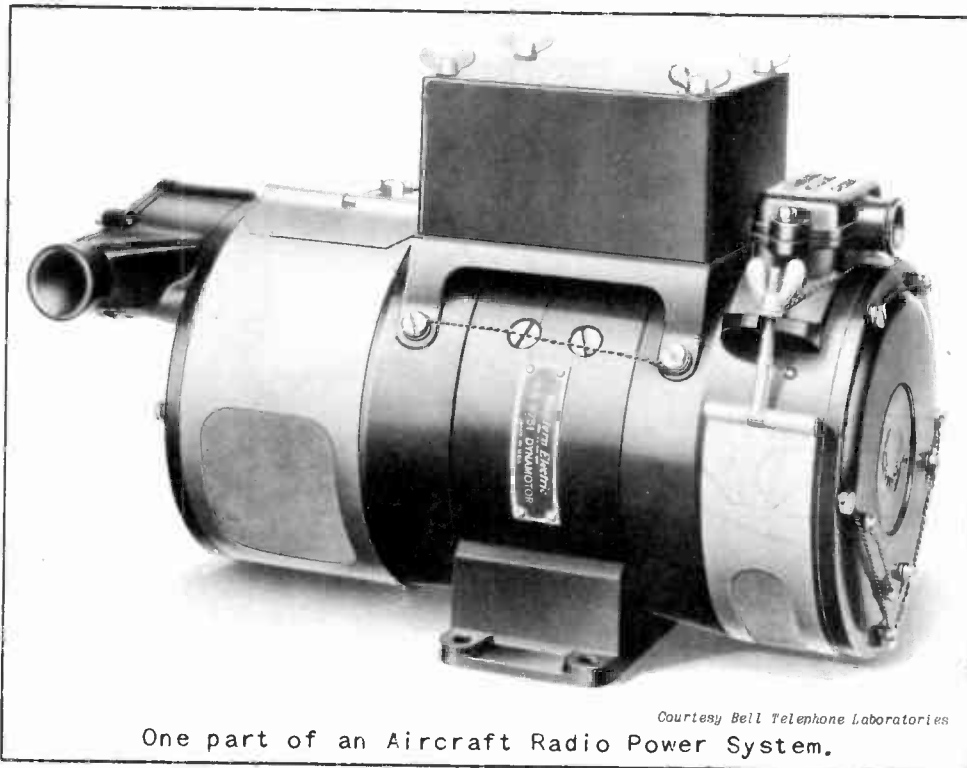

*A Radio Corporation
of America Subsidiary*

HOME OFFICE
75 Varick Street, New York
NEW YORK, N.Y. CHICAGO, ILL. PHILADELPHIA, PA. BOSTON, MASS.



Courtesy Bell Telephone Laboratories

One part of an Aircraft Radio Power System.

Aviation Radio Power Equipment

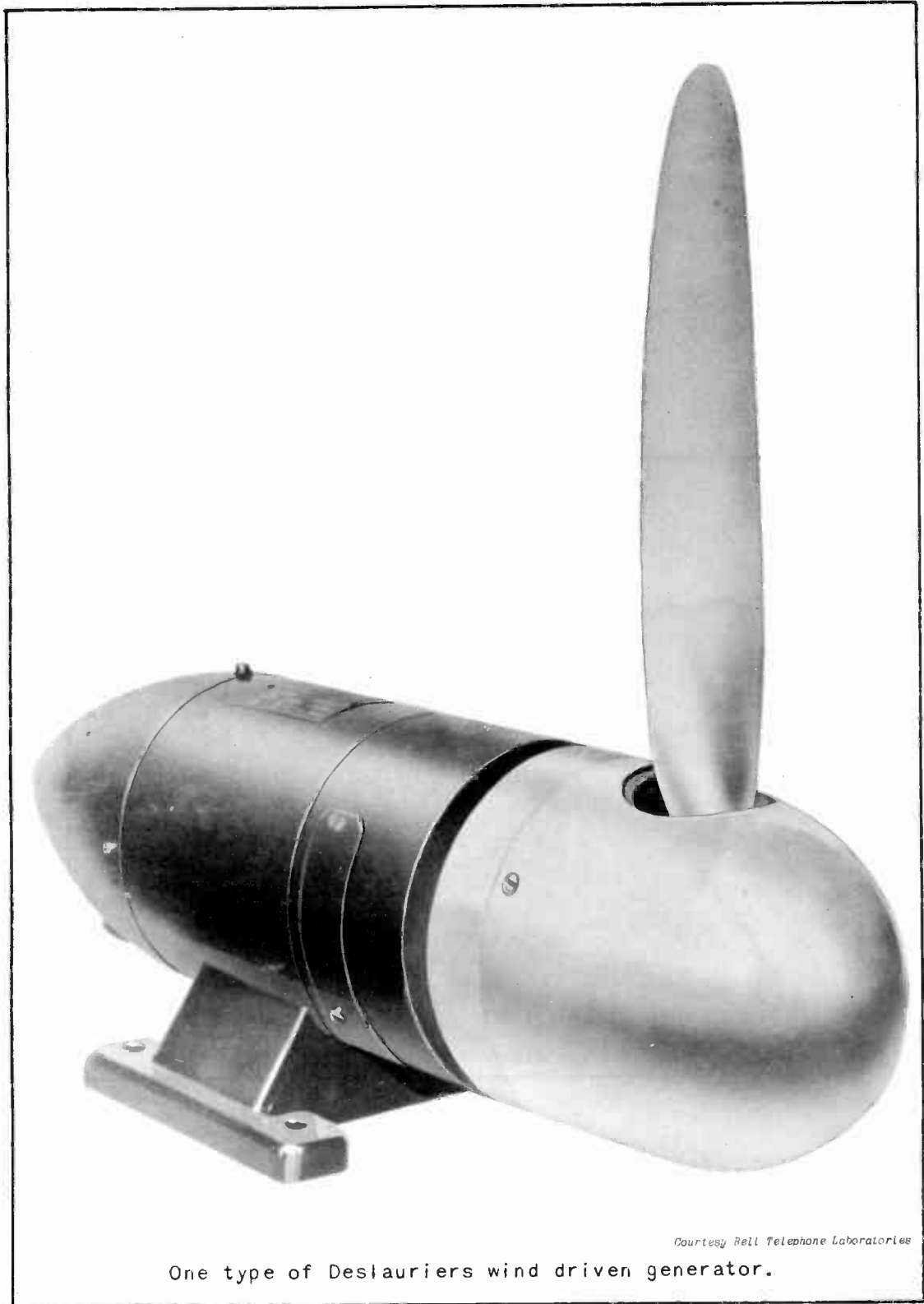

Courtesy Bell Telephone Laboratories

One type of Deslauriers wind driven generator.

America's Oldest Radio School



AVIATION RADIO POWER EQUIPMENT

Power supplies used in aviation in conjunction with radio sets can be classified in many ways. The broadest classification is probably best indicated by considering the sources of power available at ground stations and the apparatus used to secure power for the radio sets on planes. Remember that the word, "aviation" applies to all of the activities associated with the flying of heavier-than-aircraft, whereas the word "aircraft" means, so far as we are concerned, the transport and private plane. The transport plane carries a transmitter and a receiver; the single pilot mail plane a receiver.

POWER SUPPLIES AT GROUND STATIONS. The choice of apparatus to be used to supply power at aviation radio stations depends upon whether or not there is a commercial source of electricity available. Most civic airports and many of the airways stations are situated close enough to some city or some power line to purchase electrical power. Some intermediate landing fields and airways beacon stations are so isolated that they must generate their own power. Gas engines are usually used at such station. In fact, all government airways stations have a gas engine-driven generator unit as an auxiliary source of power. Practically all ground stations also have a bank of storage batteries which can be used in an emergency. The problem of planning out a suitable power installation at a ground station becomes comparatively simple when it is known what that station is to be used for. This is true because every radio transmitter and receiver requires certain voltages, whether AC or DC. Therefore, when commercial power is available, the dynamotor or motor generator, and battery become a part of the general equipment. The dynamotor selected is one that will run when supplied from the current commercially available. The generator end of this dynamotor will deliver a suitable voltage for charging the storage battery used as an auxiliary source. This battery can usually be made to drive the motor end of another motor generator set or dynamotor.

Typical power installations as found at numerous airways stations will be described later on. In the meantime, remember that they consist of a primary source such as a generator, either owned by some power company or installed at the airways station, some kind of rotary converter device for creating the kind of electricity needed at the station, and storage batteries which are kept fully charged, as reserve power. (Figure 1 shows one type of motor generator set now in use at certain radiobeacon stations.)

AIRCRAFT RADIO POWER SYSTEMS. This term should not be confused with plane power systems, even though some part of the plane power supplies may be used as a part of the radio power supply system. (As in the case where the plane's storage battery or its charging generator, is also used in connection with the radio installation.) The various pieces of apparatus which go to make up the power supply unit for an airplane radio installation is commonly referred to as a "power unit" or "power pack". These radio power supply systems are usually made up of some combination of the following units: (1) Batteries, dry and storage; (2) Generators, wind-driven and engine-driven; (3) Dynamotors. There is another power system coming into use which utilizes rectifiers, but the three units just listed above are the three which we must consider most important.

It will be well for you to note at this time that there are certain very desirable qualities which all power packs should possess. The most important of these is reliability. Planes will actually be ordered to stop flying if their source of radio power fails. It is also essential that the power supply remain adequate; that proper voltage and amperage be deliverable at all times. A power pack should be designed to stand a certain overload, although the operator should not overload his set. A third quality desired is that any DC voltage delivered be without ripple and that any AC voltage delivered be of constant frequency. An important requirement from the commercial point of view is that power equipment not be too expensive, either as to original cost or upkeep. It should be rugged, well shielded and not too heavy.

Storage batteries are much favored in aviation as an A(filament)-voltage supply for aircraft receivers, although planes desiring lighter radio equipment sometimes use dry batteries. The voltage desired does not usually exceed 10.5. As you know, the plate circuit of a receiver requires a much higher voltage than the filament. For this reason, special dry batteries delivering up to 235 volts are available. When a higher voltage than this is desired aboard an airplane, a dynamotor is usually employed. These dynamotors usually supply any specified voltage, 1050 being the highest voltage now employed. Generators, either wind or engine-driven are available which will supply both a low and a high voltage in the one machine. These will be described in detail in this lesson.

BATTERIES.

The student has already learned a great deal about batteries as primary and storage batteries were both fully discussed in previous lessons. As batteries are an extremely important part of the power equipment of radio equipped planes and at airways radio stations, they will be again discussed at this time.

DRY BATTERIES. Dry batteries are often used as B batteries in connection with aircraft radio receivers. When first installed, they are tested for voltage three ways: open circuit, with the normal load imposed by the receiver; and (momentarily) under a dead short condition. A "log" or record is kept of the total ampere-hours furnished by each B battery installed and this record, combined with the periodic voltage-reading tests, as mentioned, will furnish the operator and radio maintenance crew with accurate information

as to the condition of the B batteries. Briefly, the condition of the battery is the most important thing for a radio operator to know about the B battery.

B batteries should be replaced at once in the event that they fail to maintain voltage under the operating conditions imposed upon them. This statement holds true whether the batteries are old or new, and whether or not they have delivered their total rated ampere-hours.

CONNECTING DRY CELLS. The e.m.f. of a dry cell in good condition is about 1.5 volts on open circuit. Due to its internal resistance, the terminal voltage drops a little when the cell starts to deliver current.

A test of a cell with a voltmeter is of no value when the cell is not delivering current, for even a cell that is almost entirely discharged will test close to 1.5 volts on open circuit. When delivering maximum current the voltage of a new cell should remain as high as one volt.

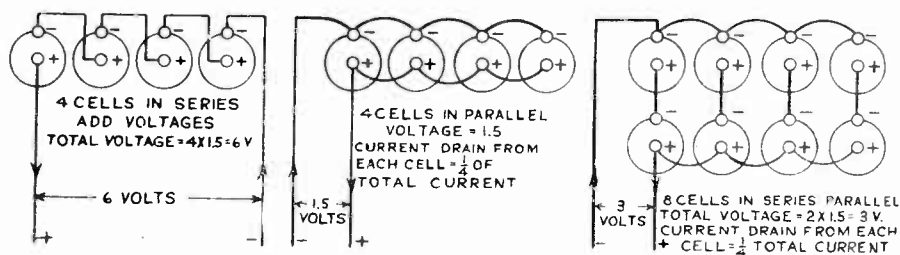

Fig. 1 - Showing different methods of connecting dry cells.

The method of testing dry cells in practice is to connect an ammeter of low resistance (less than .01 ohm) directly across the terminals of the cell. On this short circuit (through the low resistance of the ammeter having a scale reading up to about 50 amperes) a 6-inch dry cell will generally deliver a current of from 25 to 30 amperes. The ammeter should be left across the terminals only long enough to take the reading. As a dry cell becomes old, its internal resistance increases so that the amount of current flowing during the short circuit test through the ammeter decreases. A 6-inch cell should not be used with aircraft radio sets if it reads less than 5 amperes on this so-called ammeter test.

In all radio diagrams a single cell is represented by a pair of parallel lines, one long and thin representing the positive terminal and the other short and thick representing the negative terminal. Figure 1 shows the various methods of connecting dry cells.

AIR-CELL BATTERIES. A new form of primary batteries has recently been developed which is an especially good type for supplying constant voltage to the filament of the two-volt tubes often employed in battery operated receivers. This new form is known as the air-

cell battery. In this type the oxygen used as a depolarizer is absorbed directly from the surrounding atmosphere instead of being supplied in the cell in the form of manganese-dioxide as is the case with the ordinary dry cell. The electrodes are made of zinc and carbon. Whereas the ordinary dry cell uses a depolarizer in the form of a paste to prevent the hydrogen (an insulator) from forming on the carbon electrodes, the air-cell uses an electrolyte solution in conjunction with a plate which is formed of a recently invented carbon of special grade. This carbon is highly porous to oxygen and has the peculiar property of extracting oxygen from the supply existing in the surrounding air. This oxygen combined with the hydrogen on the zinc electrodes causes water to form within the cells. The electrolyte used is a solution of sodium hydroxide (caustic soda), and the active ingredient is zinc. As the zinc dissolves in the electrolyte, a chemical reaction takes place which produces as a waste product, sodium zincate. In addition to these elementary materials, the battery also contains a certain amount of calcium hydroxide. The purpose of the calcium hydroxide is to rejuvenate the spent electrolyte. The sodium zincate, which results when the zinc goes into solution reacts on the calcium hydroxide with the result that calcium zincate is produced, plus sodium hydroxide. Inasmuch as sodium hydroxide is the required electrolyte, this material evolved from the above reaction is available for further dissolution of zinc.

To place the battery in service, all that is needed to be done is to remove the covers from the electrodes so that they can "breathe" oxygen, punch out the membranes in the bottom of the filter holes, and fill the two compartments with cold drinking water. A total of about six quarts of water is required. This battery has a very definite overload point which should not be exceeded. The overload point is determined by the maximum rate at which the carbon electrode can extract oxygen from the surrounding air and amounts to approximately .75 amperes. At current drains below this figure, the porous carbon is able to replenish the oxygen as rapidly as it is consumed within the battery, and as long as the carbon contains oxygen, it repels water and remains dry. This type battery has a current capacity rating of 600 ampere-hours. Remember that it is a primary battery, and therefore cannot be recharged. When completely discharged it is worthless and must be discarded.

STORAGE BATTERIES. Aircraft radio storage batteries are not essentially different from ordinary radio batteries, except that they are equipped with non-spillable vent plugs and are usually placed in an additional container, which is often clamped shut.

It is desirable that the aviation radio operator have a good general knowledge of the construction and theory of storage batteries so that he may properly inspect, repair and service them. The most important work in servicing batteries, of course, is the charging and discharging. The charging of batteries is usually done by some radioman in the ground crew whereas the discharging is under cognizance of the operator who uses the battery after it is installed on the plane. Many companies require that the radio operator assigned to a plane test and maintain fully charged two or more batteries assigned to his plane, two or more being signed for by

him in order that he may have available, by proper management, one fully charged battery at the beginning of each scheduled flight. In this case the operator keeps a complete record of all service rendered by the battery in ampere hours and all service rendered to the battery in the way of charging, testing, etc.

A storage battery is defined as a connected group of two or more electro-chemical cells for the generation of electrical energy in which the cells after being discharged may be restored to a charged condition by connecting current to flow in a direction opposite to the flow of current when the battery discharges. Common usage permits this designation to be applied to a single cell used independently.

A storage cell is defined as the unit of the battery, consisting of positive and negative plates, separators, electrolyte and container, for the generation of electrical energy and capable of being recharged by an electric current.

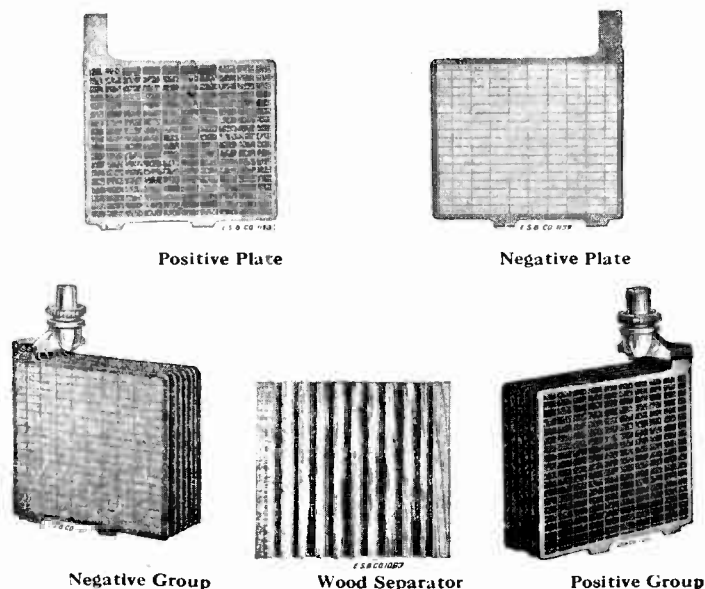

Fig. 2A - The different parts of a lead storage battery.

Active materials are the materials on plates which react chemically to produce electrical energy during the discharge. The active materials of storage cells are restored to their original composition in the charged condition, by oxidation or reduction processes produced by the charging current. In the charged condition the active materials are as follows:

<u>Plate</u>	<u>Lead-acid cells</u>	<u>Nickel-iron alkaline cells(Edison)</u>
Positive	Lead peroxide	Oxides of nickel
Negative	Sponge lead	Iron

The grid is a metallic framework for conducting the electric

current and supporting the active material. The positive plate is the grid and active material from which the current flows to the external circuit when the battery is discharging. The negative plate is the grid and active material to which the current flows from the external circuit when the battery is discharging.

Electrolyte is an aqueous solution of sulphuric acid used in lead cells and of certain hydroxides used in nickel-iron alkaline cells. The concentration of the solutions varies somewhat with the type of cell, its use and condition. The electrolyte of charged cells at 70° Fahrenheit (21° cent.) will ordinarily fall within certain limits of specific gravity.

The number of ampere-hours which can be delivered by a cell or battery under specified conditions as to temperature, rate of discharge and final voltage is the capacity of the cell or battery.

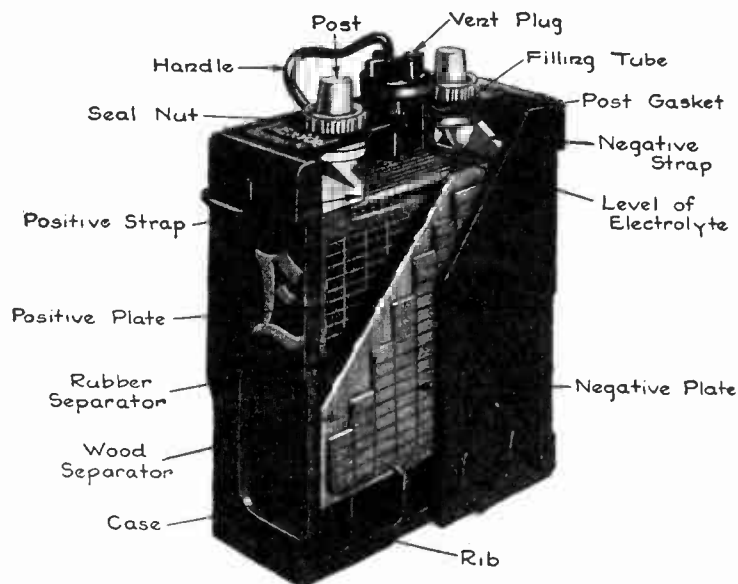

Fig. 2B - A cut-away view of lead storage cell.

Watt-hour capacity is the number of watt-hours which can be delivered by a cell or battery under specified conditions as to temperature, rate of discharge and final voltage.

The time-rate is the rate in amperes at which a battery will be fully discharged in a specified time, under specified conditions of temperature and final voltage. Example, the eight-hour rate or the twenty-minute rate.

Charge is the conversion of electrical energy into chemical energy within the cell of battery. This consists of the restoration of the active materials by passing a uni-directional current through the cell or battery. A battery or cell which is said to be "charged" is understood to be fully charged.

Discharge is the conversion of the chemical energy of the battery into electrical energy.

The charging rate is the current expressed in amperes at which a battery is charged. The finishing rate is the rate of charge expressed in amperes which the charging current for some types of lead batteries is reduced near the end of charge to prevent excessive gassing and temperature rise.

A charge in which the current is maintained at constant value is called a constant-current charge. For some types of lead batteries this may involve two rates, called the starting, and the finishing, rates.

A constant voltage charge is a charge in which the voltage at the terminals of the battery is held at a constant value. A modified constant is usually one in which the voltage of the charging circuit is held substantially constant, but a fixed resistance is inserted in the battery circuit producing a rising voltage characteristic at the battery terminals as the charge progresses. This term is also applied to other methods of producing automatically a similar characteristic.

A boost charge is a partial charge, usually at a high rate for a short period.

An equalizing charge is an extended charge given to a battery to insure the complete restoration of the active materials in all the plates of all the cells.

A trickle charge is a continuous charge at a low rate approximately equal to the internal losses and suitable to maintain the battery in a fully charged condition. This term is also applied to very low rates of charge suitable not only for compensating for internal losses, but to restore intermittent discharges of small amount delivered from time to time to the load circuit.

"Floating" is a method of operation in which a constant voltage is applied to the battery terminals sufficient to maintain an approximately constant state of charge.

The electrolyte of lead-acid batteries increases in concentration to a fixed maximum value during charge and decreases during discharge. The concentration is usually expressed as the specific gravity of the solution. The variation of specific gravity of the solution affords an approximate indication of the state of charge.

The specific gravity of the electrolyte in nickel-iron alkaline (Edison) batteries does not change appreciably during charge or discharge and therefore does not indicate the state of charge. The specific gravities, however, are indication of the electrochemical usefulness of the electrolyte.

Gassing is the evolution of oxygen or hydrogen, or both. Batteries are usually rated in terms of the number of ampere-hours which they are capable of delivering when fully charged and under specified conditions as to temperature, rate of discharge and final

voltage. For different classes of service, different time-rates are frequently used.

LEAD STORAGE BATTERY. Lead storage batteries used in aircraft radio work are classified as portable type batteries. The 6-cell or 12-volt type is more often used than the 6-volt type, especially when a dynamotor is used. The monobloc rubber or composition case is now in almost universal use in most portable batteries. This case is made of hard rubber or composition, formed under pressure, the cell partitions being in one piece with the walls and bottom. This eliminates the use of separate rubber jars for each cell and makes a case which is not affected by acid, dirt, water or oil. While installing, removing, or inspecting batteries, the radioman should carefully note any cracks, dents or abrasions that may develop into a leak.

The cells are arranged in the case in such a manner that the positive terminal of one cell is adjacent to the negative terminal of the next cell. A short, heavy bar of lead called a top connector is used to connect the cells of the battery in series. After all the top connectors are in place there will be a positive post of one cell and a negative post of another cell available as battery terminals. Terminal connectors are placed on the terminal posts to connect the battery to the electric circuit of the radio set.

The cell or battery unit contains five fundamental battery parts: the positive plates, the negative plates, the insulation between the plates, the electrolyte or battery solution and a hard rubber jar. The cover is also of hard rubber and is sealed into the jar with a plastic sealing compound. The cover is fitted around the posts of the element to prevent any leakage of the battery solution at this place.

Ribs or plate rests are placed in the bottom of the jar. These ribs, besides supporting the plates in place, provide a space of collecting the material that has been worn from the plates during service. In the cover of each cell is an opening into which is secured a vent plug. This opening provides a place for the regular testing of the solution and replenishing with distilled water which is necessary. The hard rubber vent plug should always be fastened in place when the battery is in service as it prevents a spilling of the solution and provides a means of escape for the gas which forms within the cell. Non-spillable plugs are fitted in all aircraft batteries.

A battery element consists of a group of positive plates and a group of negative plates assembled together with the necessary insulation between them. For special purposes the plates are limited to a certain size and the common method of building up the elements is to increase the number of plates, to increase capacity.

In the construction of groups, a number of plates of one kind are welded to a connecting strap by the process known as lead burning. The number (and size) of plates so used determines the capacity. It will always be found that there is one more negative plate in each element than there are positive plates in order to

permit the uniform working of all the positive plates in the group. The radio and lighting battery generally contains from three to eight positive plates and four to nine negative plates in the respective groups.

The positive and negative plates are made up of a frame work or grid, the openings of which are filled with a paste of lead oxides. These oxides become the active material of the finished plate. One form of grid is cast from an alloy which consists principally of lead to give the proper mechanical strength.

After the plates are pasted, they are dried and formed, that is, the lead oxides are changed into the active material by placing them in tanks of weak acid solution and charging them at a low rate. When completely formed, the paste in the positive plate has become peroxide of lead and the paste in the negative plate has become sponge lead. The finished positive plate can be determined by its color which is chocolate brown while the finished negative plate is a dull slate gray.

A battery element is defined as a group of positive and a group of negative plates assembled together with the necessary insulation between the plates. The insulation is placed between the plates so that there can be no contact between any of the positive and negative plates within the cell. If, at any time, a connection occurs between the two groups, causing a short circuit, the battery becomes inoperative. Proper insulation between the plates, therefore, is of vital importance.

The materials used between the plates of various aircraft radio and lighting batteries may be grouped as follows:

1. A wood sheet or separator.
2. The combination of a perforated hard rubber sheet and a wood sheet.
3. Threaded rubber insulation.

Thin pieces of porous wood are used in the manufacture of wood separators. These pieces of wood are grooved vertically and are then treated. This treatment removes the principal injurious substances the wood may contain which would be detrimental to the operation of the battery. The separators are then washed in water and usually kept in a moist condition until they are used between the battery plates.

Wood separators are cut from selected Port Orford Cedar and treated by the most improved processes, making them as near perfect as wood insulators can be. The treatment they receive removes all substances that would be detrimental to the battery. At the same time it assures separators of uniform porosity without reducing the natural strength of the wood. (Remember this when replacing, during overhaul.)

To assist in conserving the life of wood, thin perforated hard rubber sheets are sometimes used in connection with the wood separators. These thin rubber sheets are perforated to permit circulation of the battery solution. The addition of this sheet (and also the increase in space between the plates due to this additional sheet) reduces the battery's capacity at high rates and also its

voltage on discharge. This is especially noticeable when the battery is at a low temperature and when it is discharged at a high rate. The student is advised to inspect a torn down lead battery at his first opportunity.

Four of the five fundamental parts that are essential to a storage battery have been discussed. We now come to the battery solution which is termed electrolyte. The electrolyte is a mixture of chemically pure sulphuric acid and pure water.

Specific gravity is defined as a comparison of the weight of acid with the weight of an equal volume of water at the same temperature. For practical purposes, instead of weighing a sample of electrolyte to obtain the specific gravity, a much simpler method has been devised. The specific gravity is obtained by means of a syringe hydrometer. (Examine one, if you are not familiar with their construction.)

In a fully charged aircraft radio battery, the specific gravity of the electrolyte should be between 1.275 and 1.295 (31.0° to 33.5° Baume). A gravity reading of 1.220 (26.5° Baume) indicates that the cell containing the electrolyte with this density is half charged. Gravity readings of 1.150 (19.5° Baume) or lower indicate that the cell is completely discharged and should be placed on charge as soon as possible. See Figure 3.

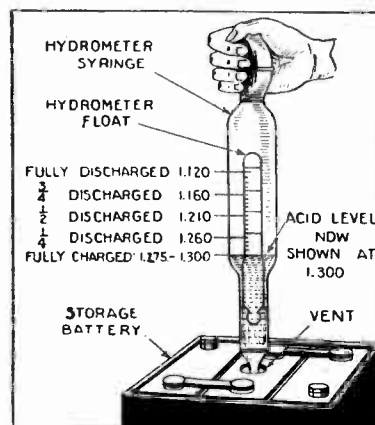

Fig. 3 - Testing with hydrometer.

Batteries in tropical countries use a lower maximum specific gravity electrolyte. When fully charged their specific gravity should be between 1.200 and 1.225. When partly charged their specific gravity is of course comparatively lower. To read the specific gravity of the electrolyte in the battery it is only necessary to:

1. Remove vent plugs from cells.
2. Compress bulb of syringe hydrometer.
3. Insert rubber tube through vent hole into electrolyte.
4. Release bulb until sufficient solution is drawn into the tube to cause the hydrometer float to rise and float freely.
5. With the syringe in vertical position so that float does not touch sides of tube, but is suspended freely in the acid, and

with the rubber bulb fully expanded, the specific gravity reading is taken on the graduated scale at the surface level of the solution.

6. Compress bulb and return electrolyte to the same cell from which it was taken.

7. Replace vent plugs.

A test made immediately after water has been added will not register correctly, since the solution must be given time to thoroughly mix. The test should be made before water is added or after the battery has been on charge or in use for a few hours.

Do not expect accurate readings from small inexpensive or inaccurate hydrometers. To get the best results use large shop type hydrometers, - and keep both float and barrel clean.

To determine the actual or true specific gravity of the electrolyte, it is necessary to check the temperature of the solution with a thermometer. If the temperature is normal (80° F.) the reading will be correct. However, if the temperature is above or below this figure, it will be necessary to make an allowance to determine the actual specific gravity. This is due to the fact that the liquid expands when warm and the same volume weighs less than when it is at normal temperature. The reverse is also true and when the temperature is below normal or 80° F. the liquid has contracted and the same volume weighs more than it does when normal.

There is a Correction Chart furnished aircraft radiomen which shows the figures to be used to make these corrections. For example, when the specific gravity, as shown by the hydrometer reading is 1.290 and the temperature of the electrolyte is 60°, it will be necessary to subtract eight points of .008 from 1.290 which gives 1.282 as the true specific gravity.

If the hydrometer reading shows 1.270, at a temperature of 110° F., it will be necessary to add twelve points or .012 to the reading which gives 1.282 as the true specific gravity.

It is never necessary to add acid to the cells of a battery unless some of the solution has spilled or leaked out. The use of an accurate voltmeter and the taking of cell voltage readings is of added help in determining the state of charge. The voltmeter is a valuable auxiliary to the hydrometer, but to use it correctly requires a more detailed knowledge of the electrical characteristics of cells on charge, effect of temperature, etc.

If both specific gravity and voltage of all cells reach the expected maximum and show no rise over a period of several hours of continuous charging, the radioman can be doubly sure all cells are charged. All voltage readings must be taken with current at the finish rate passing through the cells. If the current varies from this rate, the readings will be misleading. Open circuit readings are valueless.

All batteries have the terminals plainly marked. Positive is marked "POS" or "P" or "+"; the negative is marked "NEG" or "N" or "-". To put a battery on charge always connect the positive

terminal of the battery to the positive charging wire and the negative terminal of the battery to the negative charging wire.

If battery is not connected to the charging wires correctly the current will pass through it in the opposite direction to that necessary to charge it. The plates will change their polarity, making positive plates out of the negative and negatives out of the positive. The reversal of plates usually ruins them.

The best way to determine the polarity of a direct current line is to use a high resistance, direct current voltmeter of sufficient range to measure its voltage.

In summer weather and in tropical climates it may be difficult to keep the temperatures of aircraft batteries on charge under 110° F. (43° C.) A safe rule to follow is to take the battery off charge and allow it to cool as soon as the temperature exceeds 110° F. is only a few degrees below the critical temperature (between 120° F. and 130° F.) at which plates and separators are seriously damaged.

Regular and systematic checking of the cell temperatures is recommended particularly when the plane habitually flies to high altitudes as the change in temperature is bound to hurt the battery. These "cold" batteries should receive a warming up charge, before the regular charging rate is applied.

There is only one practical rule for all charging: - Charge until all cells gas freely and the specific gravity of all cells stops rising over a period of several hours continued charging.

Hydrometer tests should be made every few hours during charge. If at any time the specific gravity exceeds the desired maximum, 1.295 (33° Baume), remove some electrolyte, add water and continue to mix thoroughly - then test again, repeating adjustment if necessary.

When the cells are fully charged the specific gravity should be fairly uniform (within .010 points) in all cells. The actual specific gravity of the cells should be between 1.270 and 1.295 at 80° F. (31° - 33° Baume at 25° C.) Old batteries, those which have lost some material through shedding, will have a somewhat lower maximum specific gravity when fully charged than new batteries will have.

It is seldom necessary to increase the specific gravity of the solution by the addition of acid. There is sufficient acid in the solution when the battery is built to last out its life, for none is lost in the gassing action or in use. This original amount of acid is in exact proportion to the amount of active material in the plates, and to increase it will damage if not ruin, both plates, and separators, shortening the life of the battery. However, when electrolyte has leaked or spilled out of the cell, adjustment of the electrolyte should be made. Bring all cells to a fully charged state, then adjust by removing some solution and adding acid (not over 1.400) then charge and test again; or else dump out all acid and replace with new at proper specific gravity.

EDISON STORAGE BATTERY. The Edison storage battery is made up with the following units: the plates are made of compounds of nickel and iron packed into reinforced perforated steel pockets. The tubes and pockets are mounted on steel grids placed in an alkaline solution and contained in a welded nickel-steel container held in hardwood trays. Figure 4 shows the interior of an Edison cell.

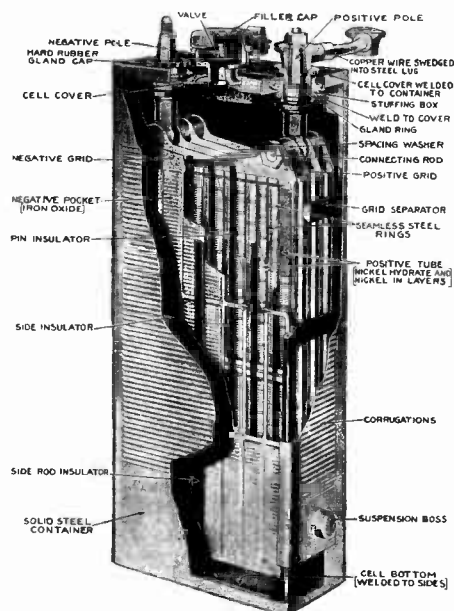

Fig. 4 - Sectional view of Edison cell.

The positive grid is made of a thin nickel-plated steel plate. This plate holds a number of tubes containing the active material, which is nickel oxide with layers of pure nickel in the form of flakes. The tubes are made of thin sheet steel and are perforated and nickel plated.

The negative plate is made of a number of rectangular pockets supported on nickel-plated steel grids. These pockets are made of finely perforated steel and are filled with the active material, which is iron oxide. These pockets, filled with the active material, are placed in the grids and put under great pressure, which forces them into perfect contact with the grid as one solid mass. After the plates are connected into one unit, special insulating strips of hard rubber are placed between them to separate and insulate them from each other. The positive pole is designated by a hard, red-rubber bushing around the positive pole together with a plus mark stamped on the cell cover near this positive pole. The negative pole is designated by a black bushing around it and has no marking on cell cover.

Cell-to-cell connections are made of nickel-plated copper soldered into lugs of nickel-plated steel. The lugs fit snugly over the tapered portions of the cell poles.

The electrolyte consists of a 21 percent solution of potash

in water with a small percent of lithia. The density of the solution is 1.210, becoming slightly less as the battery ages.

The first or initial charge reduces the iron oxide to a metallic iron, while converting the nickel hydrate to a very high oxide, black in color.

On discharge the metallic iron goes back to iron oxide, and the high nickel oxide goes to a lower oxide, but not back to its original form of nickel hydrate. On every cycle thereafter the negative charges to metallic iron and discharges to iron oxide, while the positive plate charges to a high nickel oxide and discharges to a lower oxide. Current passing in the direction of charge or discharge decomposes the potassium hydrate of the electrolyte and brings about the oxidation and reduction of the active material. An amount of potassium hydrate equal to that decomposed is always formed at one of the electrodes by a secondary chemical reaction. In consequence, none of the potassium hydrate is lost, and the specific gravity of the electrolyte remains constant. As the specific gravity remains constant, hydrometer readings are worthless, and in order to ascertain the state of charge or discharge it is necessary to read the cell voltage while the battery is on charge or discharge.

Under proper treatment Edison cells will improve with use. A new cell will continue to increase in capacity for a period of at least 30 cycles of charge and discharge. If a new battery or one which has been standing idle for a long time operates somewhat sluggishly, use it as much as possible, giving it occasional complete discharges, and it will soon pick up to normal capacity. If the capacity of the battery falls off, it is usually an indication that the electrolyte needs to be changed. Empty old electrolyte and refill with new solution, taking care to use a black iron funnel and earthenware pitcher. Never use tin or enamel funnel. Keep the salt deposits that collect on tops of cells cleaned off at all times, and keep cell tops and containers coated with vaseline compound. (Never put acid in an Edison battery.) An Edison cell can remain idle for long periods without charging and not sustain serious damage. Always keep in a dry place. Never bring a naked flame near any battery that is being charged, as hydrogen and oxygen gasses are given off and will ignite very readily. Edison batteries will freeze in temperatures of 25° F. below zero. If possible, an even temperature, not too warm, should be maintained.

GENERATORS.

The generation of electricity has been discussed in previous lesson texts. Remember that to generate electricity there must be relative motion between conductors and a magnetic field. The application of the principles involved in the generation of electricity by means of the generators used in aircraft radio installations becomes the subject of special interest in this part of the course. The d.c. generator, used in aircraft, consists of a rotating armature between one or more pairs of magnetic poles. It should be borne in mind that a.c. is induced in this armature and that a commutator is mounted on the rotating shaft which carries the armature for the purpose of leading this a.c. out of the

armature in one direction only. It is most important that this commutation be as perfect as possible and that all voltage ripple due to commutation be filtered out of the radio circuit.

You have already learned that there are two conditions that must be met in order that electricity may be produced from a generator of the d.c. revolving armature type being discussed - the field coils must be excited and the armature must be revolved. Electricity is required for the excitation process and mechanical energy is required to rotate the armature. The more current fed into the field coils, the greater will be the field strength and, (when the armature is being driven at a constant speed) the greater the field strength, the greater the voltage generated in the armature. Every effort is made in aviation radio work to maintain the revolutions per minute (r.p.m.) at a predetermined fixed value, consequently the varying of the field strength by controlling the field current becomes the means by which the voltage of the generator is controlled.

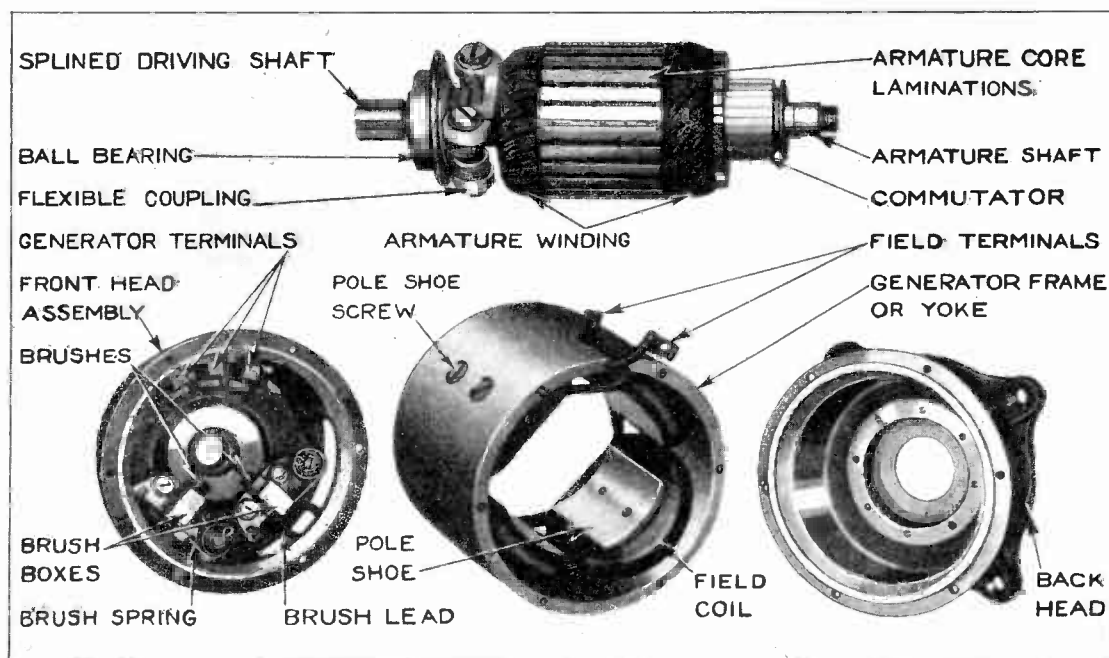
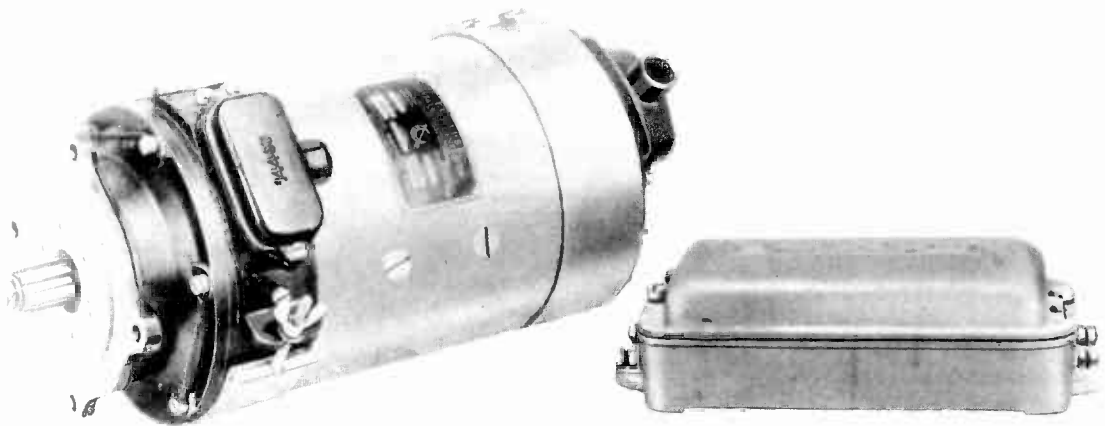

Fig. 5A - Disassembled view - Eclipse engine-driven generator.

ECLIPSE DIRECT AIRCRAFT ENGINE-DRIVEN GENERATOR.

Figure 5A shows the parts of an Eclipse constant voltage type generator manufactured by the Eclipse Aviation Corporation. It is marketed by several distributors of aircraft radio sets, particularly Western Electric Company in conjunction with their aircraft radio sets. This is a D.C. shunt wound self excited type,

having 4 poles. It is bolted to the engine and is driven by the airplane engine through a splined driving shaft. A flexible spring coupling is usually connected between a driving shaft and the armature to absorb the vibratory torque from the engine crank shaft. This generator develops one voltage only, - 14.5 volts. (Other "double voltage" Eclipse generators deliver 1050 volts and 12 volts, or almost any two voltages as required by the radio set with which they are used.) Figure 5B shows the Eclipse generator and control box.



Courtesy Bell Telephone Laboratories

Fig. 5B - Eclipse constant voltage engine-driven generator and control box.

THE CONTROL BOX.

The voltage regulating unit is shown on the left hand side Fig. 7 showing the control box board assembly, and consists mainly of a frame on which is mounted a core having a shunt winding connected across the generator terminals. A fixed contact is mounted on the frame and a movable contact fastened to an armature and held closed against the fixed contact by an adjustable retracting spring which at the same time holds the armature away from the core. A resistance unit is connected across the contacts. The position of the fixed contact can be adjusted by means of the screw, on which it is mounted.

The operation of the unit is as follows. The current in

this winding and resultant magnetic pull on the armature is dependent upon the voltage developed by the generator. With increasing generator speed the voltage increases until it reaches the normal value for which the regulator is adjusted. With a further increase in generator speed, the voltage will tend to rise above the normal value. When, however, this value is exceeded by a very small amount, the increased pull exerted on the armature carrying the moving contact overcomes the pull of the spring and the armature will be drawn towards the core, thus opening the contacts and inserting the resistance in the generator's field circuit.

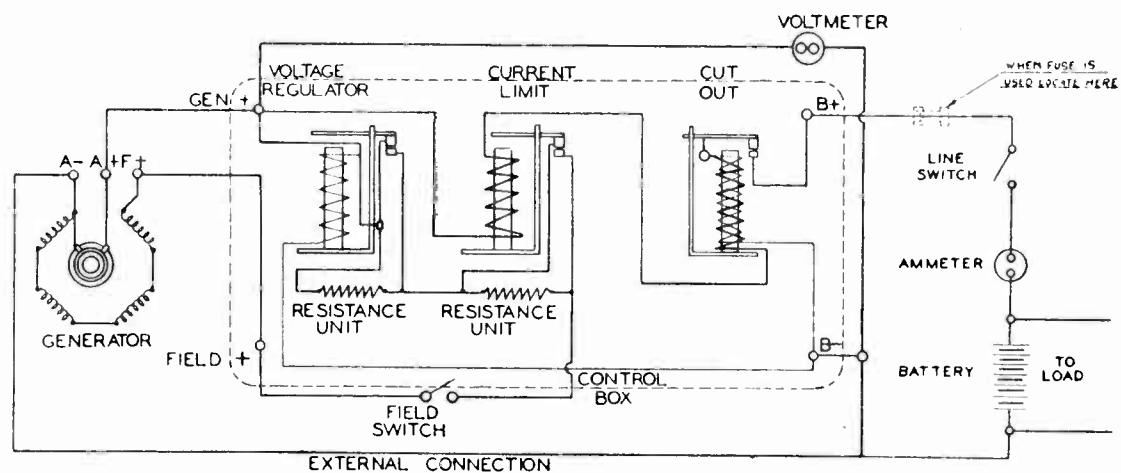

Fig. 6 - Schematic wiring diagram of Eclipse generator and control box CB-2.

The added resistance in the field circuit decreases the exciting current in the field winding and the voltage developed tends to drop below the normal value.

A control box, as shown in Figures 6 and 7, is supplied with each Eclipse generator. There are three distinct elements within the control box, namely; the reverse current cutout, load limit controller and voltage regulator element. The function of the first two named is to automatically open and close at the proper time, the electrical connection between the generator and storage battery. A device of this kind is necessary to prevent the battery from discharging back into the generator when the generator is idle or operating at a low speed.

The "cut out", shown on right hand side of Figure 7, consists of a magnet core having two windings on it, a stationary contact, and a moving armature with contact. One of the windings is a shunt coil of many turns of fine wire and is connected across the generator terminals. The other winding consists of a few turns and is connected in series with the generator battery circuit when the contacts are closed. When the generator is not running, the contacts are held apart by the spring which is fastened to one end of the cut out armature. When the generator is run and has developed sufficient speed, the shunt winding is sufficiently energized to attract the armature carrying the movable contact, thereby closing the circuit between the generator and battery. With this circuit closed, a small current flows through the series winding and energizes it. The pull exerted by this winding reinforces the pull of the shunt winding and holds the armature of the cutout in its closed position. When the generator is "dead" or the voltage falls below that of the battery, a discharge of the battery through the series winding takes place and demagnetizes the coil, thus allowing the spring to break the contact.

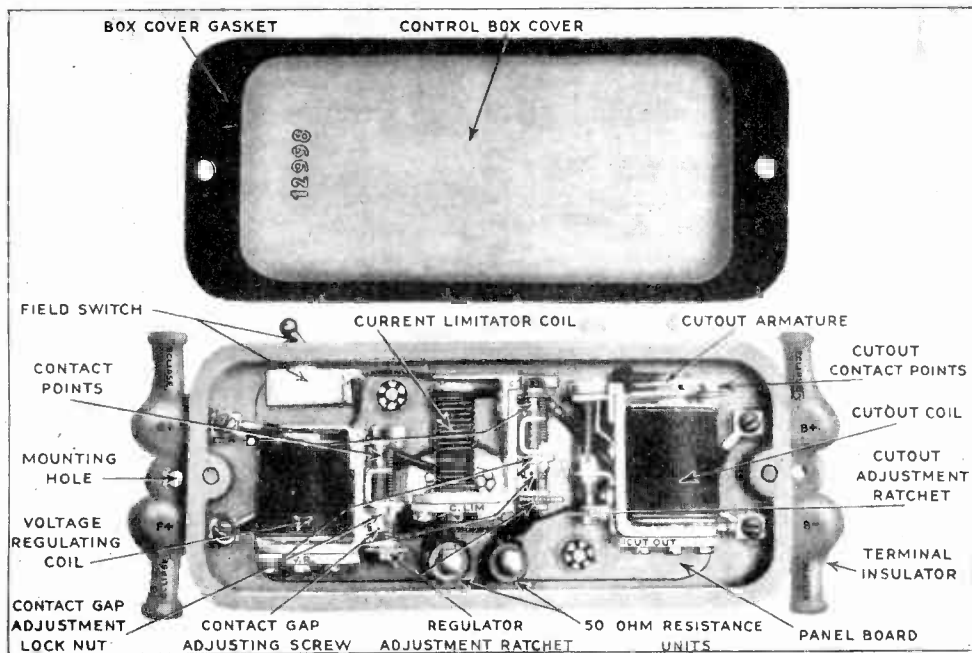

Fig. 7 - Interior view - Type CB-2 Control Box for Eclipse generator.

SERVICING THE GENERATOR.

Removal of the generator from the engine for periodic inspection is advisable. The most convenient time to do this is when the engine is taken down for overhauling. If in disassembly of

this generator, it becomes necessary to dismantle the flexible coupling, before doing so, the exact position of the spring holders should be noted. Upon re-assembly, if the holders are set up to their original position, the correct spring tension in the coupling will be maintained. After the assembly the holders should be re-wired with brass tie wire to prevent disturbance.

All parts should be thoroughly cleaned and bearings properly packed with a good grade of neutral grease of high melting point. New oil sealing washers should be installed at this time and the generator given a run at about 400 r.p.m. or more over a period of one hour on a test bench, before re-installation on the engine.

Figures 8 and 9 show the current limiter and cutout, respectively.

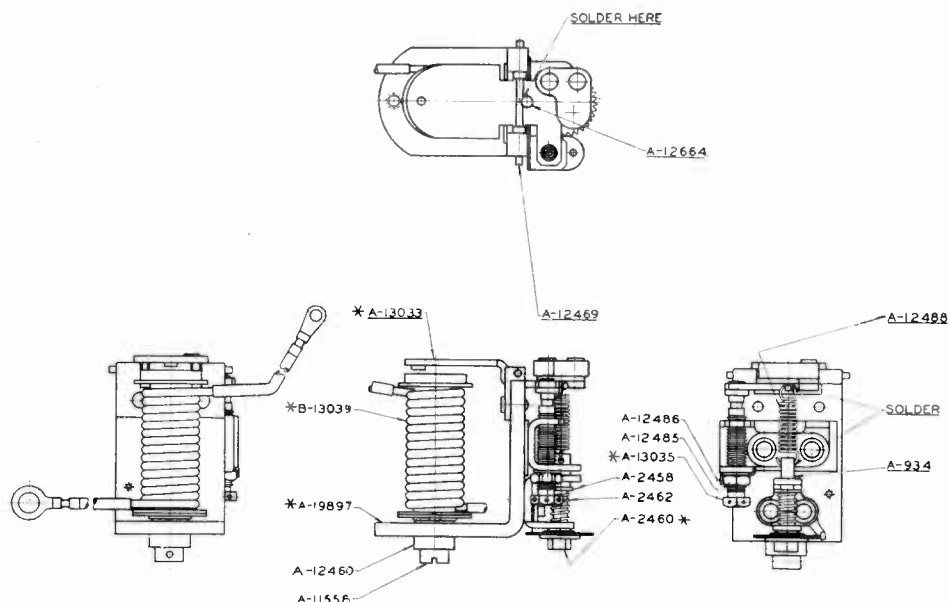

Fig. 8 - Current limiter, detailed assembly.

Grease and oil should not be permitted to collect on the commutators. If dirt, oil, or grease is present, it should be removed and the commutators cleaned with a clean cloth. DO NOT SAND-PAPER the commutators unless absolutely necessary to remove roughness. In time the commutators SHOULD be covered with a dark, semi-transparent film which should be preserved thereon.

The natural wear of the brushes causes carbon dust to collect on the interior of the generator; and this accumulation mixed

with oil vapor will form a gummy paste, which readily adheres to the brushes, causing the latter to stick. The brushes should be kept free in their respective boxes and when necessary may be washed in gasoline and thoroughly dried before reassembling.

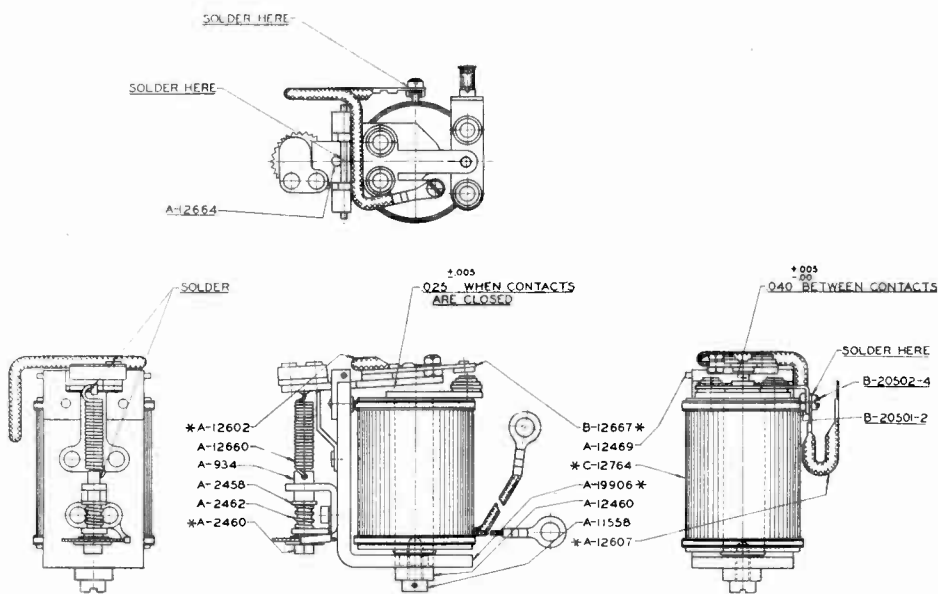

Fig. 9 - Cutout - detailed assembly.

It is of extreme importance that the generator brushes make full contact with the commutator surface. Reseating of the brushes may be quickly accomplished if necessary, by inserting a strip of No. 00 sandpaper (sanded side against brush) between the brushes and commutator, then withdrawing sandpaper against the rotation of the armature. Sand particles should be blown out of the generator after this operation. This should be carefully and thoroughly done.

Before reassembling the generator, the oil seal washers should be examined and if found to be damaged or worn, they should be replaced at once. No difficulty with engine oil seepage should be experienced if oil seals are properly assembled.

The following points should be carefully noted:

1. Bearings should be properly lubricated.
2. Window cover straps should be kept tight.
3. Brushes and brush boards should be kept clean.
4. Commutators must be smooth and free from dirt and grease.
5. Brushes must make full contact with commutator surfaces.

6. Brushes must move freely in their respective holders.
7. Brush spring pressure on low voltage brushes should not exceed 24 ounces. The high voltage springs should have 12 ounces of pressure.

Figure 10 gives you the wiring diagram for the Eclipse generator.

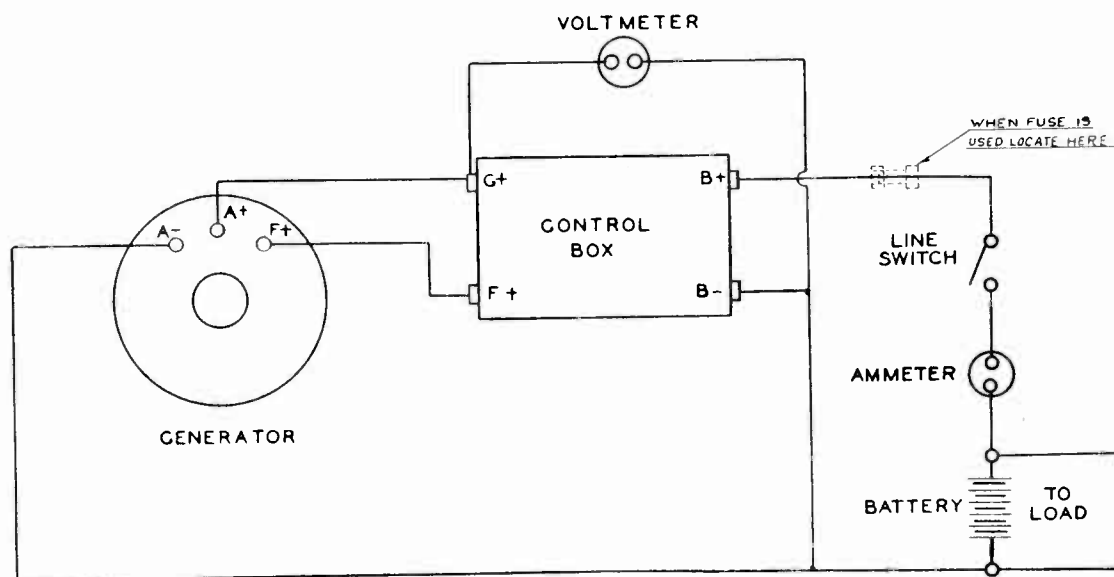

Fig. 10 - External wiring diagram of generator and control box.

It is extremely important that the interior of the control box be kept thoroughly clean in order to avoid the entrance of dirt particles between the contact points of the regulating and cutout devices. Dirt causes the burning and oxidization of the contacts, which in turn causes the relay units to become erratic and finally inoperative.

These contact points should be restored to their proper condition by smoothing with a small strip of Crocus Cloth every 50 hours of operation. Meter readings are the only accurate method of ascertaining the proper functioning of the apparatus.

Should any of the units require adjustment, turning the ratchet wheel in a clockwise direction raises and turning in a counter-clockwise direction reduces the voltage or overload settings. The cutout is properly set at the factory and no attention need be given to it except for occasional inspection of the contact points.

The contact gaps on either the voltage regulators or the

current limitator should not be changed and under no circumstances should the regulator spring tensions be changed in an endeavor to increase the charging rate or the "cut-in" speed of the generator.

CONSTANT SPEED AIRPLANE ENGINE DRIVEN GENERATORS.

The aviation industry is coming to regard the airplane engine-driven generator as one of the most desirable types of aircraft radio power equipment. Entirely satisfactory performance, however, has not been obtained with this type of generator in the past. The difficulties encountered with engine-driven generators have been due, principally, to the necessity of providing constant voltage at the variable engine speed, necessary in flight maneuvers. Attempts have been made to use many kinds of electrical regulators, but only one type of regulator has proved at all practical. This is the vibrating contact regulator already described. It is difficult to keep this type of regulator in correct adjustment because of the continual burning of the contacts. Operators state that they are fairly satisfactory for battery charging if they are "kicked" occasionally when the contacts stick. For double-voltage radio generators they are of doubtful value. Not only does the rate of contact burning increase with the increased size of the generator, but also the value of the voltage obtained is very irregular.

As generator voltage is dependent on generator speed, the electrical regulator could be dispensed with altogether if a speed regulating mechanism could be developed which would hold the generator speed within close limits in spite of variations in engine speed.

Such a speed regulating mechanism has now been developed by Westinghouse Electric and Manufacturing Company. The generator is designed so that it will be revolving at the required speed when the airplane engine is turned over at slightly below the cruising speed of the airplane. The generator itself is driven through a friction mechanism which is centrifugally controlled. Therefore, if the generator reaches a speed higher than its rated speed, there will no longer be any driving friction. The generator operates at a speed where the driving torque balances the required torque. If you increase the load on the generator, you increase the torque. In this case, the generator will decrease the r.p.m. just enough to develop the additional torque required. As the regulating mechanism is developed, a small change in speed is equivalent to a large change in torque. In short, the generator speed is independent of the driving speed. The slipping mechanism has this advantage; it protects the generator from the vibratory torque on the direct driven type of generator. This coupling usually contains rubber blocks and springs and is not entirely satisfactory. The constant speed generator has this advantage; no such coupling is necessary.

The friction elements in the Westinghouse speed regulating mechanism will last from 600 to 1,500 hours, according to the service to which the generator is subjected.

It has not been considered desirable by Westinghouse to

develop a double voltage direct current generator using this mechanism. The alternating current machine is much more compact, is considered much more reliable and efficient and is much lighter in weight than the direct current machine.

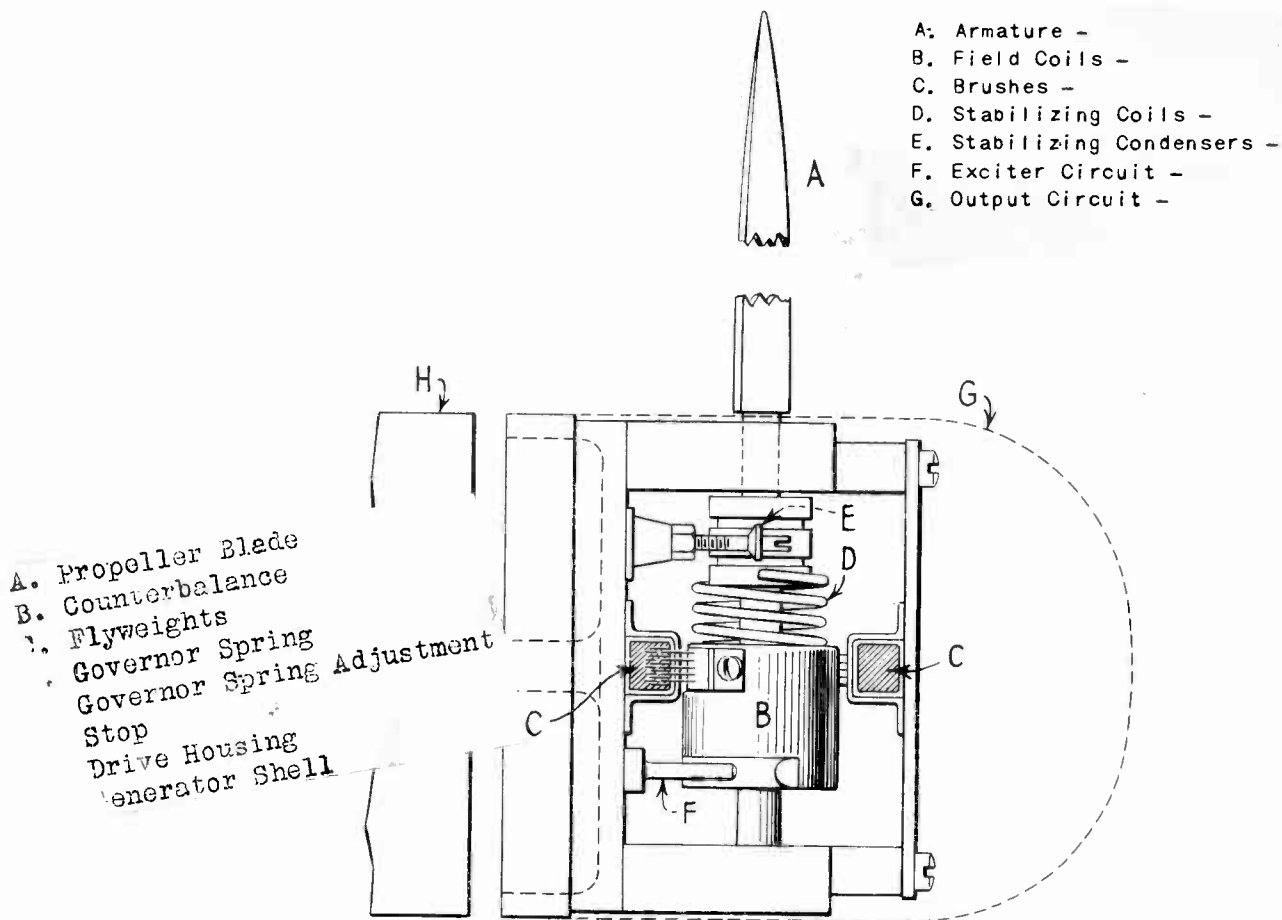

Fig. 11 - Diagrammatic sketch, Deslauriers propeller head mechanism.

Mathematically, the efficiency of a mechanism of this type, which delivers the same torque that is applied at less than the applied speed, can be expressed by the following simple formula where N is the generator speed and N_d is the driving speed:

$$\text{Efficiency} = \frac{N}{N_d}$$

From this it will be seen that the efficiency is a direct ratio between the generator speed and the driving speed.

Where emergency power is required, that is, for battery and dynamotor systems, the constant speed, 15 volt generator is an ideal machine for keeping the battery charged. For control it requires only an ammeter to indicate the charging rate at the desired value and a reverse current relay. It should outlast the engine with no attention other than routine lubrication and cleansing.

When one set of friction elements has been worn out a new set can be installed without difficulty.

Operating tests have been made by Westinghouse Electric and Manufacturing Company on constant speed generators for nearly a year now and this type of generator has been found to be satisfactory beyond all expectations. The a.c. machines were originally received with considerable skepticism, but all who have operated them have given favorable reports on their performance.

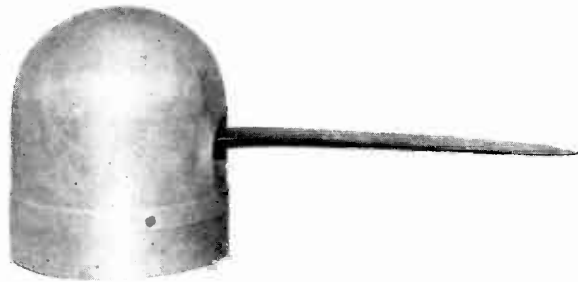

Fig. 12A - Deslauriers propeller and head.

WIND-DRIVEN GENERATORS. The electrical characteristics of wind-driven generators are precisely the same as engine-driven generators. The control of speed, which directly influences the voltage generated, however, becomes an important item. The propeller most used in this country is the Deslauriers propeller. Practically all wind-driven generators, no matter by whom manufactured, are known as Deslauriers generators because they are invariably equipped with the

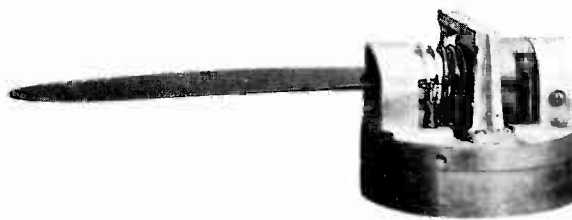

Fig. 12B - Deslauriers propeller showing head mechanism.

Deslauriers propeller. This propeller is a single bladed type with a slight double camber. Figure 11 shows the general scheme of this propeller with its governing mechanism in the head of the generator. The overall case, which is stream lined, is shown in Figure 12A, the interior mechanism in Figure 12B. Figure 13 shows the circuit of one type of Deslauriers generator, designed to be separately excited from an outside source of from 10 to 14 volts. Practically all Des-

lauriers generators have shunt or compound wound field coils; most of them have the shunt field separately excited.

The method of regulating the speed is most interesting and important. The propeller is turned over by the impact of air due to the plane being in flight. It can also be made to revolve by mounting the generator in the "slip stream" of the airplane engine propeller, in which case power can be secured from this type generator whenever the airplane engine is running, even if the plane is not flying. It is desirable, however, for the aircraft radio generator to run at a constant speed, irrespective of the air speed of the plane which varies over a wide range, minimum speed being attained at the maximum climbing angle of the plane, and maximum air speed being attained in a full dive position. There are also short intervals during some flights when the plane is "slipping" down sideways, or "skidding" up sideways, during which time a plane actually does

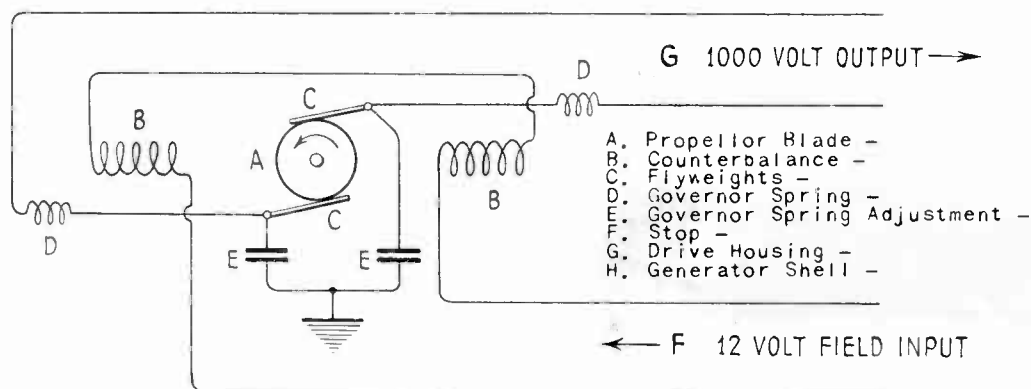

Fig. 13 - Wiring diagram of separately excited Deslauriers generator.

not have flying speed. At such times there is no relative movement (no air speed) between the plane, as to forward motion, and the atmosphere. Because of these varied conditions of flight, ranging from 100% less than normal air speed (the stalling position of the plane) to about 60% more than normal flying speed (force of gravity being in full play), the governing of the speed of a wind-driven generator is absolutely essential. This is true for two reasons in particular. One is that electricity is desired from the generator at all times and the other is that if the r.p.m. is decreased, the voltage will decrease, while if r.p.m. is increased the voltage will increase up to the point where considerable damage will be done by the excess voltage generated.

The theory of the Deslauriers propeller is very simple. All propellers act as screws. It is easy to understand that in the case of a fine screw thread - a large number of threads to the inch - less energy is required to turn it than if the thread is coarse. In the first case, we say that the bite of the screw (or the pitch of the propeller), is less than in the second case. Power for driving the Deslauriers propeller is received from the blast of air. This propeller pivots at its base so that the pitch decreases with an increase of air pressure - in other words the blade flattens out as

the airplane increases speed. Look at Figure 11 again. Observe that the propeller is held in position by the spring D. The centrifugal force due to the propeller revolving, carries the flyweights C out from the center, until they act as a governor. The governor spring adjustment is provided to increase the tension of the governor spring for each desired r.p.m. Propellers as installed on aircraft

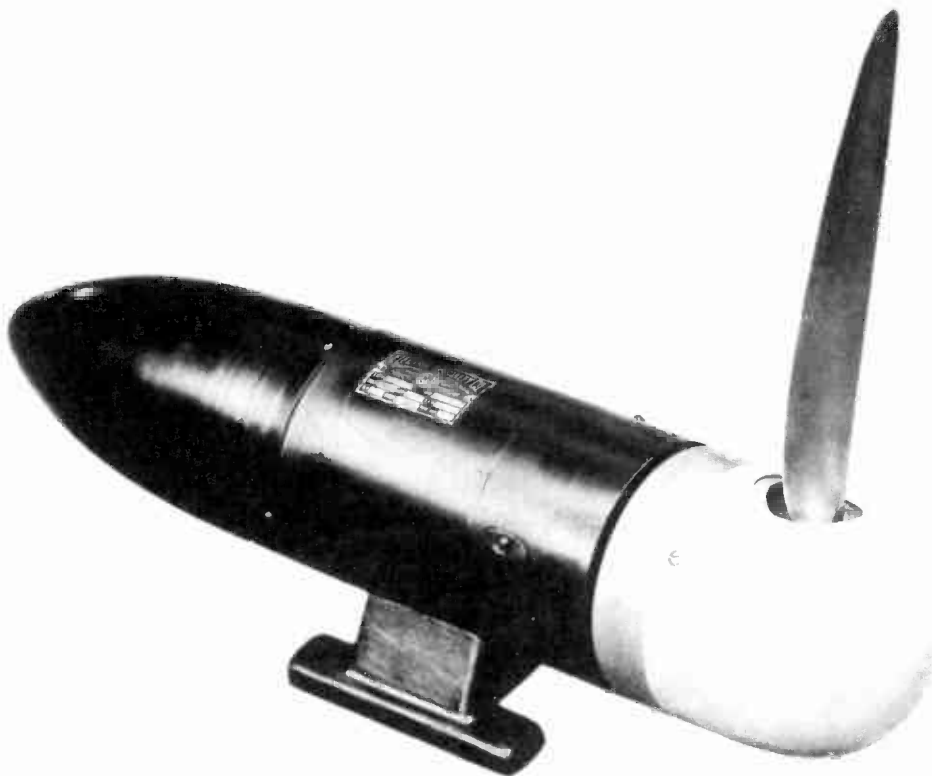
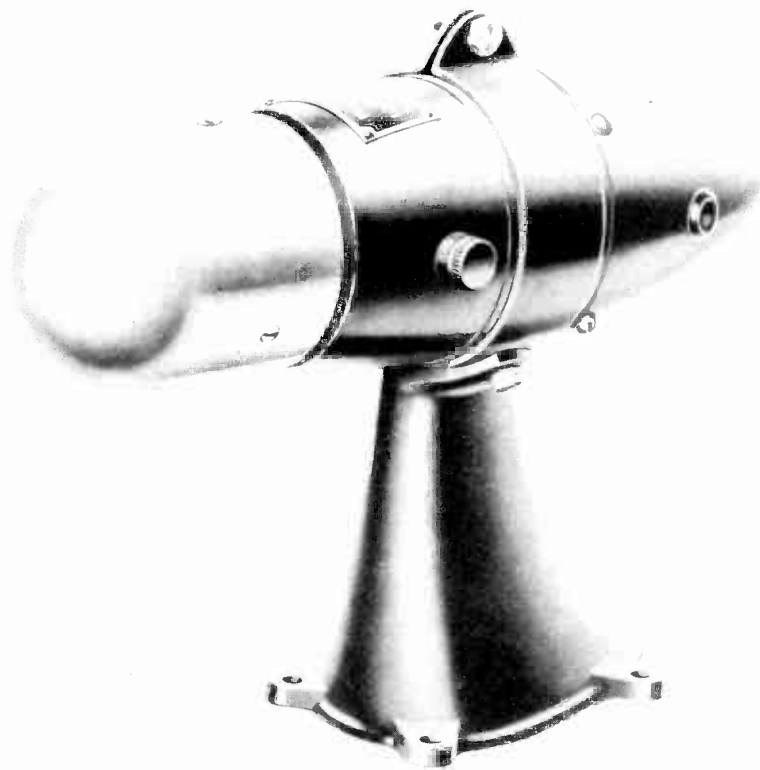

Fig. 14 - Double voltage generator with constant speed Deslauriers propeller.

radio generators are adjusted for the specified r.p.m. desired as the normal air speed of the plane on which the generator is to be installed is known beforehand. The mechanism just described will then operate to maintain the r.p.m. throughout the most extreme fluctuations in air speed attained by the plane in flight. For this reason it is not necessary to have a voltage regulator device such as has been explained for use with the engine-driven generator. Deslauriers propeller-driven generators can be used to supply power to receivers and to transmitters. They are often wound with two armature windings in order to provide two sources of e.m.f. of different value. (Such as shown in Figure 14.) There is also a Deslauriers wind-driven generator supplying both high and low voltage, which in case of a forced landing can be operated as a dynamotor from a storage battery, giving full emergency communication. The propeller for this generator is equipped with a ratchet device eliminating even the necessity of removing same when operated as a dynamotor. The battery which "floats" across the low tension side of generator is fully charged at all times and ready for dynamotor or emergency

operation by simply throwing a switch. Another advantage of this ratchet device is that if the plane is flying below the speed at which the propeller will develop its full load, the switch can be thrown while in flight, and full communication maintained. This is exceedingly important in case of a forced landing, because on the glide to such a landing, the switch can be thrown if the speed falls too low, and communication maintained continuously.



Courtesy Bell Telephone Laboratories

Fig. 15 - Wind-driven generator mounted in bracket.

Figure 15 shows a wind-driven generator fastened in a mounting bracket manufactured by the Electrical Specialty Company for the Western Electric Company. This machine is a double-voltage generator which may be used as a source of power supply for Western Electric aircraft radio receivers. The low voltage winding will supply either 1.6 or 3.2 amperes at 13 volts and the high voltage winding will supply either 25 or 50 milliamperes at 220 volts when the machine is operated at its rated speed of 6,500 r.p.m. In order to prevent any frequency noise produced at the brushes of the generator from affecting the receiver a radio frequency filter is placed in the plus 13 volt lead. This filter consists of a retardation coil and a condenser. As this generator is only to be used with radio receivers having equipotential cathode tubes, it is not necessary to have an audio frequency filter in the low voltage supply.

The generator should be mounted on some convenient part of the plane using a mounting bracket as shown in Figure 15. As the power of the propeller is sufficiently great to insure that the generator comes up to operating speed for all air speeds greater than 70 miles per hour, it is not necessary that the generator be mounted in the slip stream of the airplane propeller.

The power cable from the generator to the other apparatus should be run in the body of the plane. A hole is provided near the upper part of the mounting bracket in order that the cable may be run inside the bracket and thus have only the short length from this hole to the cable opening in the generator tailpiece exposed. In all cases the cable should be fastened to the leading edge of the strut (at intervals not exceeding 8 inches) as this has the least detrimental effect on the stream lining. Any desired method of fastening which is sufficiently solid may be used.

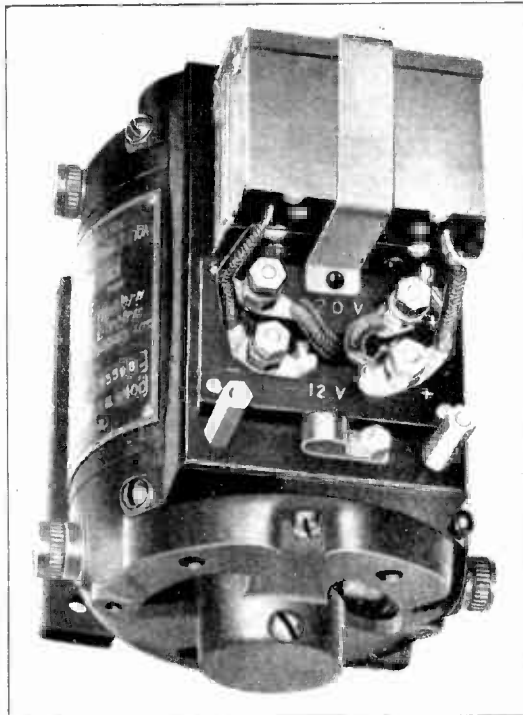

Fig. 16 - Dynamotor showing filter.

When installed in an all-metal plane the cable should be bonded to the metallic surface at frequent intervals. When installed in a plane which is not of all-metal construction, the cable should be bonded to any metallic surface with which it comes in contact. This bonding should be done with a considerable degree of care, as poor joints which make intermittent contact will introduce a great deal of noise due to the varying resistance of the ground return path.

DYNAMOTORS.

Generators and motors are both dynamo-electric machines. A generator is a dynamo-electric machine whereby mechanical energy is converted into electrical energy, whereas a motor is a dynamo-electric machine whereby electric energy is converted into mechanical energy. You realize that any d.c. generator can be used as a motor and vice versa.

The need for a motor in connection with aircraft radio sets lies in the fact that it is considered very desirable to be able to generate a suitable source of d.c. without having any power available due to the movement of the plane in flight, or any due to the running of the airplane engine either. For this reason, dynamotors are used. A dynamotor consists essentially of a rotating armature having double windings and double field pole windings. These armature coils are wound in the same manner as in the case of a double voltage generator. There are two commutators on the shaft, one at each end of the armature. One commutator is connected to what is called the motor armature coils, or the primary end, and the other commutator is connected to the generator coils or the secondary end. Such a dynamotor is shown in Figure 16. This dynamotor (No. KS-6589) is made by the Electric Specialty Company for the Western Electric Company. A dynamotor like this is practically required when a receiver is used which requires a fairly high voltage for the plate circuit.

When the 12-volt starting and lighting battery of the plane is utilized for operating the radio receiver, the No. KS-6589 dynamotor is used to supply the necessary high voltage for the plate circuit. This dynamotor takes approximately 3.5 amperes at 12 volts and delivers 0.050 ampere at 220 volts.

As mentioned before, any type of rotating electrical machinery using brushes produces radio frequency noise when operating because of sparking between the brushes and the commutator. In order to suppress this interference at the source this dynamotor is equipped with a filter which consists of two 1-microfarad condensers, one of which is connected across each set of brushes. This filter will eliminate any radio frequency interference due to sparking at the brushes.

Dynamotors may be installed at any convenient part of the airplane, the only requirement being that the axis of the armature is horizontal under normal operating conditions. It is desirable to mount the machine in such a position that the total length of lead carrying a comparatively heavy current from the storage battery to dynamotor be as short as possible. As the control switch for starting and stopping the dynamotor is located in one of the other control units, the total length of battery cable consists of the length from the storage battery to the control unit plus that from the control unit to the dynamotor.

The dynamotor is not completely shielded, so in order to prevent direct pickup of radio frequency disturbance the machine should be located as far as possible from the radio receiver and antenna, within the limits imposed by the requirement that the battery supply lead be as short as possible.

While it is unnecessary to provide for thorough ventilation, the machine should not be placed in a small closed compartment where there is no circulation of air.

ECLIPSE AVIATION DYNAMOTOR - TYPE A. The Eclipse Type A dynamotor has been designed by the manufacturer to operate from the standard airplane battery delivering from 12 to 15 volts. The capacity of the airplane battery should be 65-ampere hours or more, although a smaller battery may be used if absolutely necessary. A pilot's switch and a magnetic relay switch is furnished with this dynamotor in order that the dynamotor itself may be mounted very close to the storage battery. This arrangement makes it possible to use heavy wire to connect the storage battery with the dynamotor, and a smaller, lighter wire for the pilot's switch, which may be placed anywhere on the plane that is most convenient. The relay is so designed and connected that the field of the dynamotor itself is energized before the armature terminals are connected to the power supply line, an arrangement which presents a large initial inrush of current at the instant of starting. This dynamotor is a four-pole machine delivering ten hundred and fifty volts at .4 amperes with an input of 11.5 volts and 65 amperes. Both the high and low voltage windings are mounted in the same armature slot and are so insulated that the armature may readily meet the standard installation breakdown test prescribed by the American Institute of Electrical Engineers. The connectors from the high and low voltage winding are brought out to commutators at opposite ends of the armature shaft.

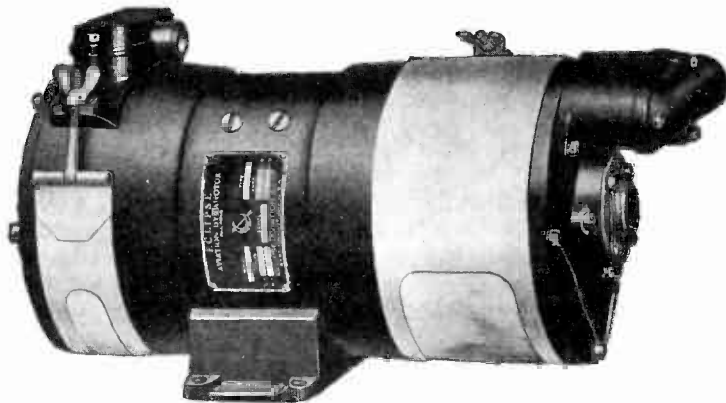

Fig. 17 - Eclipse Type "A" Dynamotor.

The fields are properly excited when the low voltage power supply, from the airplane storage battery, is so connected that the rotation of the armature when viewed from the low voltage commutator end of the shaft is clock-wise. To reduce electrical interference from the occasional sparking of the brushes and to aid in shielding, the low voltage negative terminal of the machine is grounded to the generator frame. When low voltage current is applied to the low voltage armature winding, the armature is caused to revolve as a motor. Care should be taken in the hookup of this machine because

if the high voltage side was connected to the plane battery the winding would not stand the overload.

The Eclipse Type A generator is shown in Figure 17. Mounted on top of the dynamotor and connected internally to the proper terminals is the filter unit. The purpose of this filter unit is to minimize the effects of slot, pole and commutator ripple, as well as to by-pass any radio frequency current set up by occasional sparking at the brushes. The manufacturers of this machine have

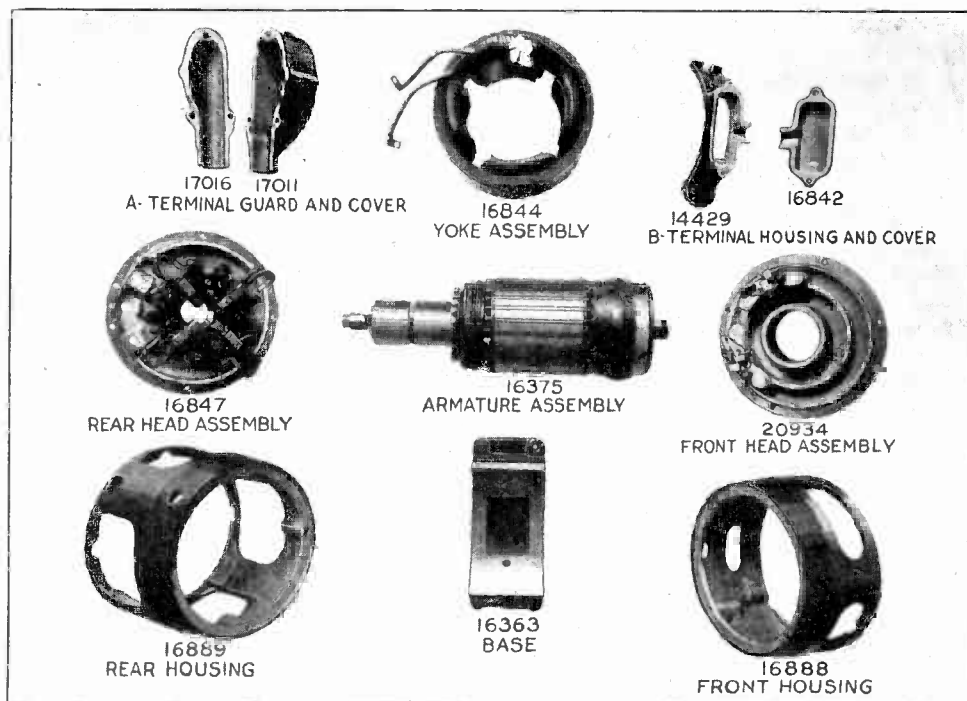

Fig. 18 - The parts of an Eclipse Dynamotor.

issued very complete instructions as to the maintenance of the dynamotor. The following points should be carefully noted:

1. High voltage brushes must be examined for wear every hundred hours of operation and low voltage brushes every two hundred hours.
2. Bearings should be properly lubricated with an approved grease of right consistency. We recommend the use of Bosch U. S. No. 501 Special High Temperature Grease distributed by the United American Bosch Corporation, Springfield, Mass. and its distributors.
3. Window cover straps must be kept tight.
4. Brushes and brush boards must be kept clean.
5. Commutators must be smooth and free from dirt or grease.
6. Brushes must make as near FULL CONTACT as possible with commutator surface.
7. Brushes must move freely in their respective holders.
8. Brush spring pressure on low voltage brushes should be 16-18 ounces. The high voltage springs require not less than 2 or more than 3 ounces to just lift the brush follower from the top of the brush box. This is done with the brush removed.

9. Neither high voltage nor low voltage commutator mica should be undercut.

If dirt, grease or oil collects on the commutator it should be removed and the commutators cleaned with a clean cloth. DO NOT SANDPAPER the commutators unless absolutely necessary to remove roughness. In time the commutators should become covered with a dark semi-transparent film which should be preserved thereon.

The natural wear of the brushes causes carbon dust to collect on the interior of the generator and this accumulation mixed with oil vapor, will form a gummy paste, which may adhere to the brushes, causing them to stick. The brushes should be kept free in their respective boxes and when necessary may be washed in gasoline and THOROUGHLY DRIED before reassembling. New brushes may be quickly seated by inserting a strip of No. 00 sandpaper (sanding side against brush) between the brushes and commutator, then withdrawing sandpaper with the rotation of the armature. Sand particles should be blown out of the dynamotor after this operation. The brushes should be given a final finish with No. 0000 sandpaper. This should be carefully and thoroughly done by personnel with experience in the process of sanding brushes.

Figure 18 shows the Eclipse generator disassembled, with all parts named.

EXAMINATION QUESTIONS.

- 1 - What is meant by aircraft radio power supplies systems?
- 2 - How are B batteries in aviation tested?
- 3 - Show by sketching a diagram how you would connect four dry cells to deliver six volts.
- 4 - What is the difference between air cell and the old form of dry cell?
- 5 - Define storage battery, electrolyte, grid, boost charge, trickle charge, floating.
- 6 - Briefly describe the Edison storage battery.
- 7 - Discuss the Eclipse engine-driven generator and control elements.
- 8 - Describe the Deslauriers wind-driven generator.
- 9 - Describe an aviation dynamotor.
- 10 - Describe a typical power supply system on a transport plane, naming all of the power units that make up the system.



Courtesy Deslauriers Column Mould Co., N. I.
Deslauriers Gear Reduction Unit with Deslauriers Constant
Speed Propeller.

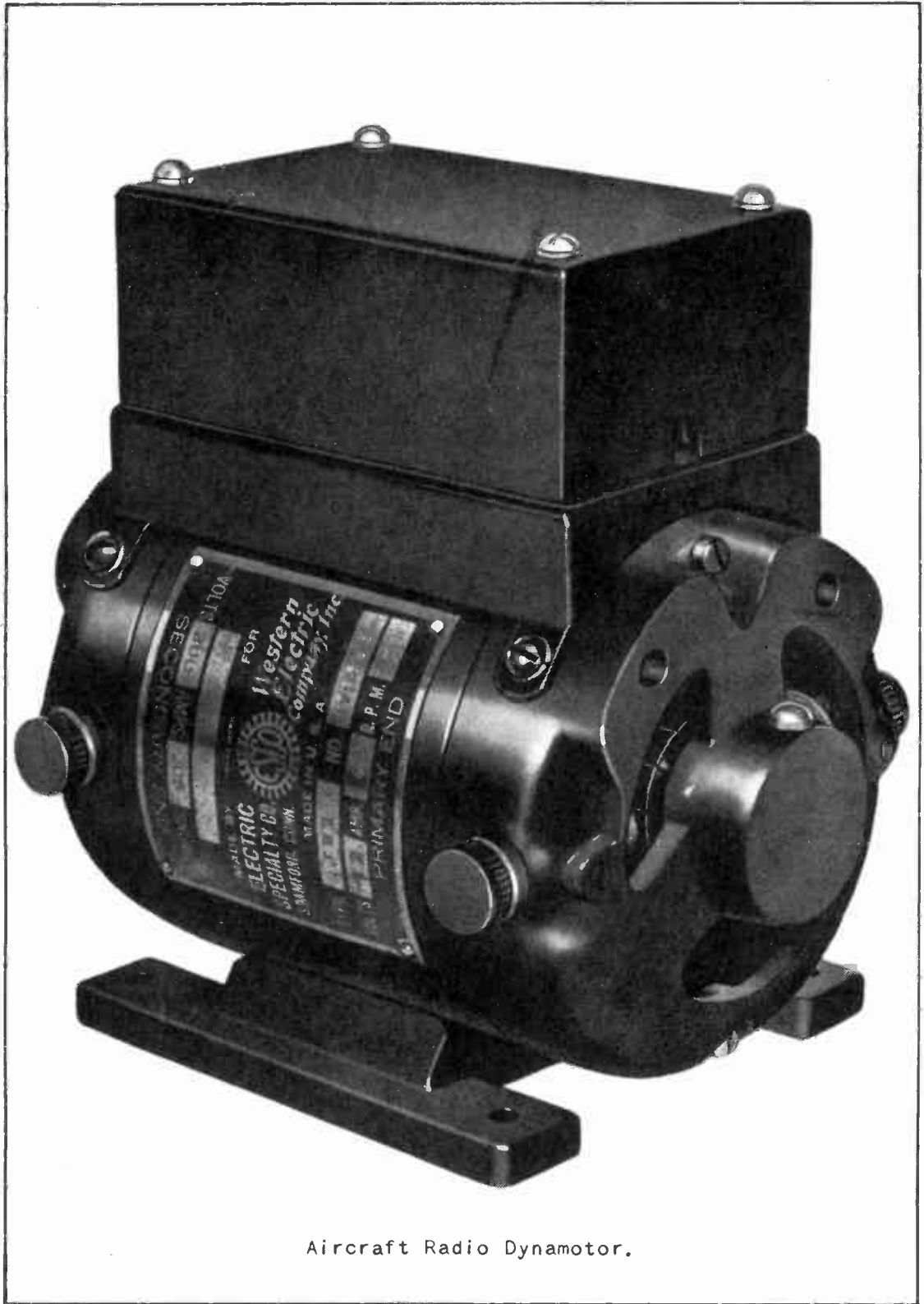

Aircraft Radio Dynamotor.