

*America's Oldest Radio School*



*A Radio Corporation  
of America Subsidiary*

HOME OFFICE  
75 Varick Street, New York



THE CORRECT FUNCTIONING OF A SUPERHETERODYNE RECEIVER IS DEPENDENT ON PROPER ALIGNMENT OF ITS I-F STAGES. AN OSCILLOGRAPH IS USED HERE TO VISUALLY CHECK ACCURACY OF I-F CONDENSER ADJUSTMENTS.

## The Development of the Superheterodyne

VOL. 16, No. 2

*Dewey Classification R161*

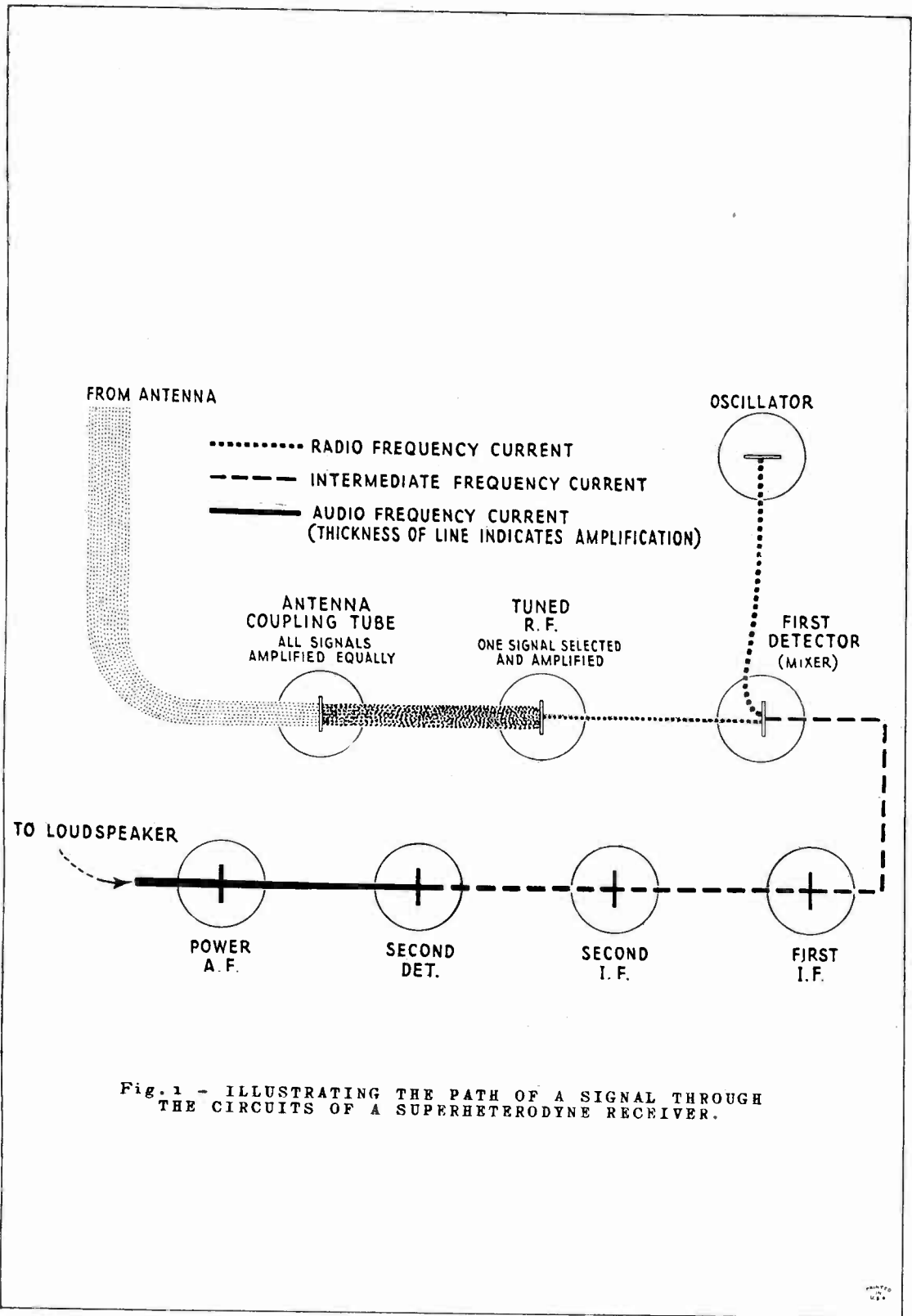

*America's Oldest Radio School*



### THE DEVELOPMENT OF THE SUPERHETERODYNE

At the very beginning of your study dealing with the development of the superheterodyne it is best to obtain a perspective of this subject by reading over the definitions of terms which apply specifically to this work. Therefore, in the paragraphs immediately following we have given the definitions of the three systems which employ the heterodyne principle for the reception of radio signals, namely; heterodyne reception, autodyne reception and superheterodyne reception.

These definitions, from the standards of the Institute of Radio Engineers, are as follows:

- (1) Heterodyne reception is the process of receiving radio waves by combining in a detector a received voltage with a locally generated voltage. The frequency of the locally generated voltage is commonly different from that of the received voltage.
- (2) Autodyne reception is a system of heterodyne reception through use of a device which is both an oscillator and a detector.
- (3) Superheterodyne reception is a method of reception in which the received voltage is combined with the voltage from a local oscillator and converted into voltage of an intermediate frequency which is usually amplified and then detected to reproduce the original signal wave.

### THE PHENOMENON OF "BEATS".

Sound. A perfect demonstration of the principle of beats can be made with three tuning forks whose frequencies are 400, 500 and 600 cycles per second. If all three forks were made to sound simultaneously, a good musician could pick out the three separate frequencies. Any person of normal hearing would also be able to distinguish sound components of other frequencies in addition to those being actually produced. The other frequencies would not actually be present in the air, but would seem to be due to a non-linear response characteristic of the human ear. The presence of the 400 cycle and 500 cycle frequencies in the ear would produce an impression of 100 cycles also being present, this being the arithmetical difference between 500 and 400; likewise the arithmetical difference between 600 and 500 cycles would represent the same effect. The difference between the 600 and the 400 cycle tones would cause the impression of a 200 cycle note being present.

The apparent presence of all these frequencies, 100, 200, 400, 500 and 600 gives a sense of pitch to the average individual corresponding

to the production of a fundamental frequency of 100 cycles plus the 2nd, 4th, 5th, and 6th harmonics of that note, as represented by the other apparent and real frequencies. There are also quite a number of other frequency-impressions that may be computed by taking the various arithmetical sums of real tuning fork frequencies, such as 900, 1000, 1100 and so on.

The principle of "beats" on which this is based covers the particular effect produced when two wave-motions of different frequency exist in a common medium, and some interpreting or translating device is used whose response does not vary linearly with the amplitude of the wave-motion. The human ear is an example.

No doubt you are by this time quite familiar with the annoying squeal produced by a regenerative radio receiver when its feed-back control is advanced too far, thus causing it to set up oscillation and in this way become a miniature transmitter of radio waves. In other words this regenerative receiver, when in an oscillating condition becomes a radio station operating on a certain frequency and its received energy is applied to the input side of the detector. If the detector tube happens to be in an oscillating condition, it may produce another current of such frequency that an audible beat-note would be produced in the headphones or loudspeaker. Furthermore, the same effect can be produced, even without a non-oscillatory detector, by one of the radio-frequency amplifier stages if it is sufficiently far from being neutralized to produce the separate oscillating current required before the beat can be produced.

Another way in which a beat effect may be produced is when some radio station is transmitting at a frequency appreciably different from its assigned carrier frequency. The carrier frequencies of radio stations are allocated so that the frequency of a given station should be 10 kc. away from the stations in the adjacent bands. However, suppose a certain station is off frequency, so that it is 18 kc. from the station on one side, and only 2 kc. from the station on the other side. If you were listening-in it would be found that this 2 kc. difference in carrier frequencies would produce a 2000 cycle beat-note in your phones or speaker.

The interesting thing about this beat effect is that you could place the headphones in series with the plate-voltage supply to any of the radio-frequency amplifier tubes, and not get the beat-note, providing, of course, the r-f tubes were perfectly linear in their grid-voltage plate current characteristic. Actually, tubes are not so perfect in this respect, and there might be a very weak beat-frequency produced. However, such a beat-frequency would not be nearly as strong as it would be if you appreciably increased the grid bias voltage on the tube in whose plate circuit the phones had been inserted. This tube would then have the non-linear response characteristic which determines the evidence of beats. From these facts it is seen that a detector of some kind is required.

It must not be assumed that beats can occur only at audio frequencies. To the contrary, we will be particularly concerned later with producing a resultant frequency which is quite above the audible range, for use in the superheterodyne reception method.

#### TWO METHODS OF AMPLIFYING RADIO SIGNALS.

Radio amplification is used before the demodulating detector is reached in order to amplify weak signals that would not otherwise actuate the detector at all. At the same time it allows the inser-

tion of successive tuned circuits designed to select a desired signal and reject others not wanted.

Audio-frequency amplification finds its use in amplifying the signal after it has been rectified by the detector, thus building up the signal to the strength necessary to operate the electrically-driven air pump which we know as a loudspeaker. This is generally accomplished with from one to three stages of voice-frequency amplification. More than this is not generally successful due to tube noises and reaction effects which destroy the quality of the signal thus amplified.

#### DIFFICULTIES ENCOUNTERED IN R-F AMPLIFICATION.

Before the advent of neutralizing of grid-plate capacity in a vacuum tube, considerable difficulty was experienced in amplifying radio-frequencies above 300 kc., due to the tendency to oscillate. Another source of trouble was in the stray inductive couplings between parts of the grid and plate circuits of tubes, and even between circuit parts which were remote from each other in the amplification line, but all too closely spaced by the requirements of convenient handling.

At a frequency of 1000 kc. a tube capacity of 8 micromicrofarads is equivalent to approximately 20,000 ohms impedance. At 50 kc., the same capacity would present an impedance of about 400,000 ohms. It is apparent then that an amplifier could be so efficiently designed at 50 kc. that its voltage gain would be considerably greater than could be achieved (with the three-electrode tube) at 1000 kc.

It was on this principle that Major E. H. Armstrong worked when he developed the superheterodyne for use in listening posts behind the lines during the World War, when a great deal depended on the interception of secret code messages passing between various units of the opposing forces.

#### THEORY OF THE SUPERHETERODYNE.

We now come to a principle used to obtain far greater amplification together with extreme selectivity and sensitivity and, while there is a similarity in some parts of the circuit to the methods just described, it will be seen that improvements are incorporated to obtain the desired results. This principle is embodied in the superheterodyne receiver.

When first developed, the receiver had about as many controls as a radio-frequency receiver of the same number of stages, but with a far greater sensitivity. In later years, the number of controls was considerably reduced because, as we shall see, certain selective circuits of the superheterodyne can be left in a tuned condition which does not vary for changes in the signal radio-frequency which it is desired to receive.

The superheterodyne receiver fundamentally consists of five main parts:

1. A radio-frequency amplifying system.
2. A frequency changing system.
3. An intermediate-frequency amplifying system.
4. A demodulator-detector.
5. An audio-frequency amplifying system.

The 1st, 4th and 5th parts are exactly the same as found in any ordinary tuned radio-frequency receiver, which uses only two frequency ranges, namely, radio and audio. The superheterodyne uses a third frequency range, which is intermediate in value between the radio and audio, and is therefore termed the "intermediate frequency".

The production of this third frequency is a local matter in the receiver itself, the frequency changing system consisting of an oscillator which provides the heterodyning frequency, and a mixer or detector which makes available the beats which constitute the intermediate frequency. This frequency is subsequently amplified selectively by means of one or more tubes associated with tuned circuits whose capacity and inductance are made fixed and resonant at the intermediate frequency which it is desired to use.

#### TRACING A RADIO SIGNAL THROUGH A SUPERHETERODYNE.

As a means of illustrating the path of a radio signal and the changes that it undergoes in passing through a superheterodyne, what may be called a current flow chart has been prepared as shown in Figure 1. It shows the path of the various current frequencies through the tubes in the set. Radio-frequency current is represented by dotted lines, intermediate-frequency current by dash lines, and audio-frequency current by a solid continuous line. Amplification is indicated by the increase in the thickness of the various lines.

The incoming signals of high frequency are the dotted lines on the extreme left. These currents come in directly from the antenna and are all amplified equally in the first stage. This amplification is indicated by an enlargement of the dots. You will note that each one has been increased by the same amount. The input to the first tube for this chart is the signal voltage developed across an untuned impedance, such as a resistance, connected between antenna and ground.

Connected to the first tube or coupling stage is the second tube or tuned radio-frequency stage which will permit current of approximately only one frequency to pass. This frequency may be selected at will. In the second stage this signal is amplified still further before being passed on. The third stage or detector is also tuned to the incoming signal.

At this detector stage the signal from the local oscillator is introduced. As you see, it is dotted, meaning high frequency. The oscillator is adjusted so that it will oscillate at a certain frequency difference from the incoming signal. These two currents of different frequency enter the detector and are mixed in such a manner that the output is of a frequency equal to the difference between them. It is important to remember that this detector is called the first detector in superheterodyne circuits.

This frequency, known as the intermediate frequency, is shown in dash lines. The audio signal, originally superimposed on the incoming radio-frequency current, is now superimposed on the intermediate-frequency current.

This combination is allowed to pass through two stages of amplification before it passes to the next tube circuit where it is detected, or demodulated. This detector, which functions to demodulate the

signal, is called the second detector in superheterodyne circuits. From the second detector we get an output current of an audible frequency, indicated by a heavy solid line. This audio current is similar in characteristics to the audio current used to modulate the carrier wave sent out from the transmitter. In order that this current may be of sufficient intensity, it is put through a stage of power amplification—indicated by an increased thickness of the solid line—before going to the speaker. Thus, we have followed the three frequencies through the tubes of the set. Before leaving this chart it may be well to point out that the regulation of the flow of current at three different radio frequencies may be controlled by one dial in most receivers, thus eliminating the difficulty of trying to perform three tuning operations at one time.

#### FREQUENCY CHANGING SYSTEM.

Since this is the most important part of the superheterodyne, and the thing that distinguishes it from other forms of receivers, we will commence our explanation with a circuit shown in Figure 2, where the radio-frequency signals are picked up by a loop antenna and fed directly into the first detector. For the present we will pass over the review of the radio-frequency amplifying system that may also be embodied in such a receiver because this subject, in general, is common to other types of receivers.

The loop pickup circuit and 1st detector in Figure 2 are shown in simplified form in Figure 3. It will be reasoned that such a circuit will serve to demodulate the radio-frequency carrier and make the audio frequencies of the received broadcast program energy available in the plate circuit. This would be true, if headphones were inserted in that circuit. However, we are not interested in listening to the program sounds as yet, because the simplicity of the single tuned circuit is such that it is both insensitive and highly unselective for our needs.

Let us leave this circuit for a moment and consider the circuit in Figure 4, which shows a simple Hartley oscillator.

This circuit consists of an inductance coil in the grid circuit and one in the plate circuit. These coils are so arranged that energy from the plate circuit coil will be inductively supplied to the grid circuit coil.

A variable condenser placed between the grid and plate sides of the two coils makes possible the tuning of the total inductance provided by these coils and also enables one to tune the system so that it will oscillate at a frequency which will permit the circuit to be used for practical reception.

Depending upon the inductance of the coils and the capacity of the condenser, the frequency can be made anything within the range of the value of these units.

With such a system capable of producing radio-frequency oscillations, we will couple it to the circuit of Figure 2 by means of a small pickup coil marked  $L_3$ . We now have three coils in the coupled oscillator,  $L_1$  in the plate circuit,  $L_2$  in the grid circuit and  $L_3$  in the grid circuit of the frequency changer or first detector. We also have two variable condensers,  $C_1$  in the first detector circuit to tune the loop, and  $C_2$  in the oscillator circuit. These are the only tuning controls necessary in the superheterodyne.

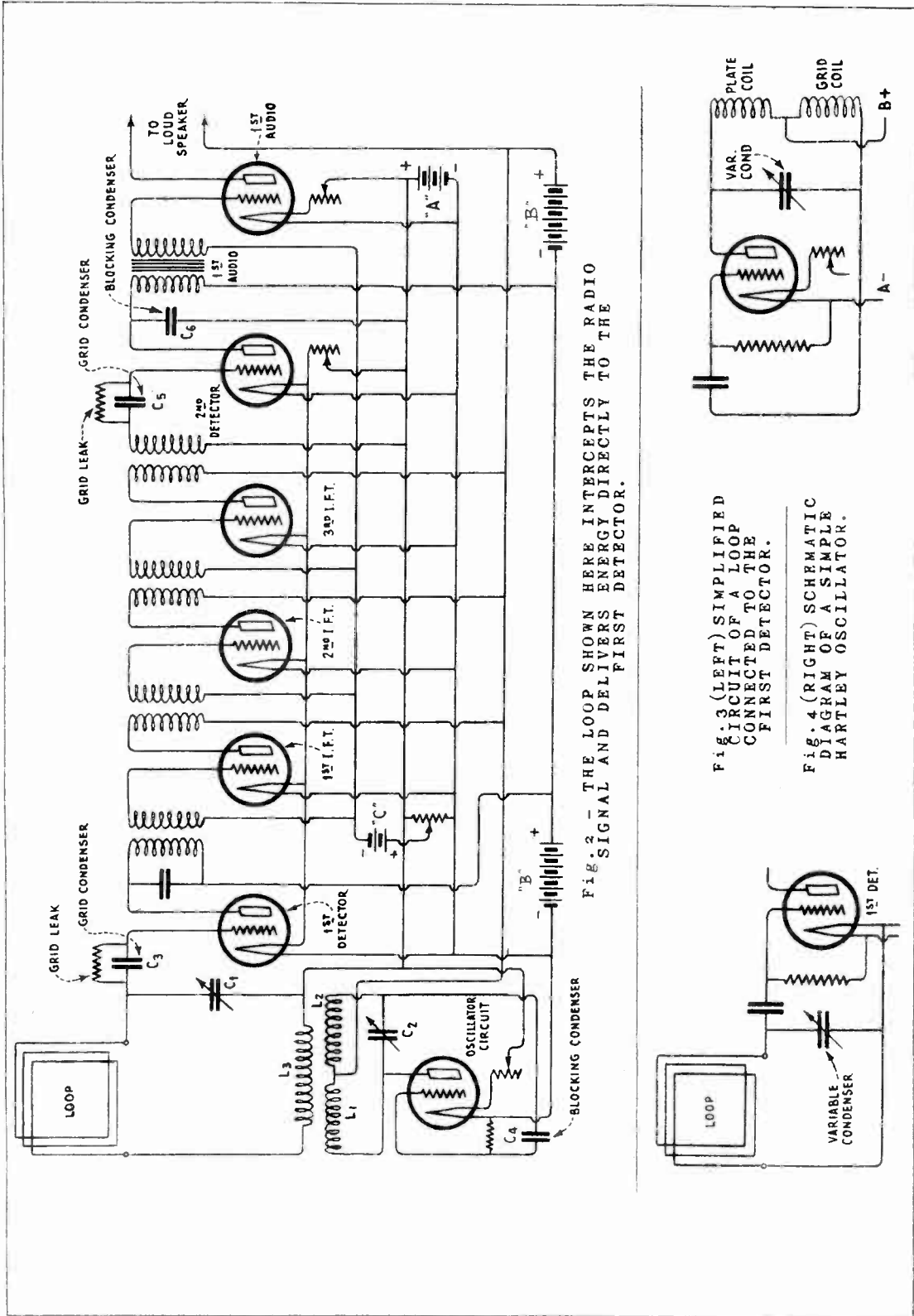

Fig. 2 - THE LOOP SHOWN HERE INTERCEPTS THE RADIO SIGNAL AND DELIVERS ENERGY DIRECTLY TO THE FIRST DETECTOR.

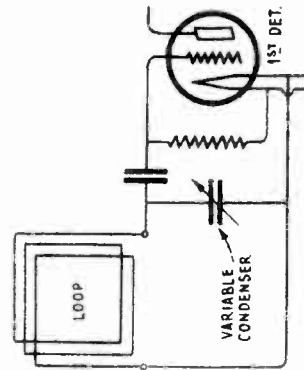

Fig. 3 (LEFT) SIMPLIFIED CIRCUIT OF A LOOP CONNECTED TO THE FIRST DETECTOR.

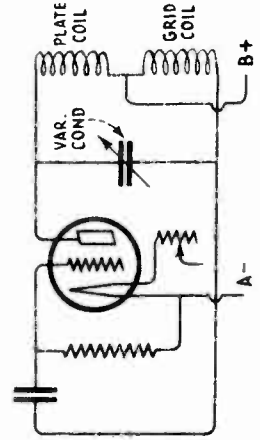

Fig. 4 (RIGHT) SCHEMATIC DIAGRAM OF A SIMPLE HARTLEY OSCILLATOR.



Now by adjusting  $C_1$ , we may have the frequency of any desired signal in the loop circuit; and the oscillator circuit may be made to produce any desired frequency independent of external signals or forces.

Let us assume that the incoming frequency oscillation picked up when tuning the loop by means of a condenser and impressed on the grid of the first detector or frequency changer is 1,000,000 cycles per second, which would be the signal from a station transmitting on a wavelength of 300 meters. The oscillator is now adjusted by means of the variable condenser  $C_2$  to a frequency of 1,180,000 per second; this frequency being impressed likewise on the grid of the first detector through pick-up coil  $L_3$ .

We now have two different frequencies being impressed on a common circuit, that is, impressed upon the grid of the first detector. When two different frequencies are thus impressed on a common circuit, they produce a third, or beat frequency, and the frequency of this beat will be the difference between the two impressed frequencies. Since the incoming frequency is 1000 kc. and the oscillator frequency 1180 kc., the difference between these two frequencies will be 180 kc. We now have a frequency which is lower than the incoming frequency of 1000 kc. to work with, namely, 180 kc., or in terms of wavelength it is higher, being equivalent to 1606 meters. This beat frequency is called the intermediate frequency, and is passed to the first intermediate frequency transformer and vacuum tube, where it is amplified and then passed on to the second and third intermediate transformers. Note that amplification can be carried on for more than two stages if desired. After passing through the intermediate-frequency amplifiers, it is impressed on the grid of the second detector.

The second detector performs the demodulating function with which you are familiar in any tuned radio-frequency amplifier system. The output of this detector is an audio-frequency voltage capable of operating headphones, or of being amplified through an audio-frequency system to provide the power level necessary to operate a loudspeaker.

#### DIFFICULTIES IN STATION SELECTION.

It will be observed that the loop antenna circuit of Figure 2 is a system used for input to the first detector. In the following paragraphs we will show that there are three undesirable features to an input system of this kind.

FIRST. An oscillator is a miniature form of transmitter. Therefore, if the loop circuit is tuned to a frequency not very far from that of the oscillator, the loop becomes a very good radiator of the energy produced by the oscillator. Since this radiation is at a frequency which is usually in the broadcast band it causes interference by the production of heterodyne whistles in nearby receivers.

SECOND. The selectivity of the single tuned circuit (loop and condenser) to incoming radio frequencies is not very good. It may be desired to receive a certain station which is transmitting on its assigned carrier frequency at a time when a nearby station of greater power but of another carrier frequency is transmitting. In this case the undesired signal will override the desired one, causing what is termed

"cross-modulation" which spoils the program. Another interference results from the fact that there are two signal radio frequencies which will combine with an oscillator frequency to produce the same beat frequency. For instance, if an oscillator at 650,000 cycles beats with radio station frequencies of either 600,000 or 700,000 cycles a beat frequency of 50,000 cycles will result in both cases. Two stations can be received at the same time if the selectivity of the system is poor between the antenna and the first detector. In this type of interference the term "image frequency" is applied to the undesired signal frequency. A further interference type occurs when two stations, whose frequencies differ by the value of the intermediate frequency, reach the first detector and by heterodyning with each other form the intermediate frequency which passes through to produce a badly garbled combined program. This can happen with the local oscillator completely removed.

THIRD. The inductive coupling between the loop circuit and the oscillator circuit causes a reaction between them when changing the constants of either one while tuning.

After exhaustive experiments a means was evolved whereby the first detector was made to function both as the oscillator and first detector, thus eliminating one tube. This was not a simple solution but one which required considerable research and time. There was finally developed a simple and effective arrangement which solved the problem completely. It consisted of connecting two tuned circuits to the oscillator; one a simple circuit which could be tuned to the frequency of the incoming signal, and the other a regenerative circuit which could be adjusted to oscillate at some particular frequency, the second harmonic of which, beating with the incoming signal frequency, would produce the frequency desired for intermediate amplification.

#### ELIMINATING RADIATION, CROSS-MODULATION AND IMAGE RESPONSE.

The use of tuned radio-frequency stages of proper design between the antenna system and the first detector will eliminate all three of the troubles just mentioned.

By the use of screen-grid tubes in r-f amplifier circuits or by properly neutralized triode amplifier circuits it is possible to prevent the antenna from radiating the energy generated by the local oscillator.

Cross-modulation in the first detector is prevented by the selective amplification of sharply tuned stages which precede this detector. The super-control tubes eliminate cross-modulation in the r-f stages. Image response is prevented by the same selectivity afforded.

The use of an intermediate frequency of the order of 180 kc. also helps, as the difference between the desired and the undesired station frequencies is 360 kc., as compared to a station frequency difference of only 80 kc. when the intermediate frequency is but 40 kc.

CONSIDERATION OF THE FREQUENCY BANDS CONCERNED.

In order to understand just what frequencies are involved in the intermediate-frequency amplifier, let us start at the radio transmitter, and review what happens when a carrier frequency of 800 kc. is modulated simultaneously by two musical notes which are at the opposite extremes in the range. These notes are, namely, the low note of the bass viol, or 40 cycles, and the highest note of the piccolo, which is about 4100 cycles. According to the side-band theory, the radio transmission would consist of the following radio frequencies:

Upper side-band due to high piccolo note.....	804,100
" " " " " low bass viol note.....	800,040
Carrier frequency.....	800,000
Lower side-band due to low bass viol note.....	799,960
" " " " " high piccolo note.....	795,900

Subtracting the lowest from the highest frequency, it is seen that a radio-frequency band 8200 cycles wide is required to transmit the highest note played as well as other lower musical frequencies created by the bass viol as fundamental and overtones, in which it is rich.

For this explanation let us assume the local oscillator provides a single radio frequency which is 980,000 cycles. When this frequency is combined with the various frequencies representing the radio program just outlined the beat frequencies will be produced as follows:

<u>Oscillator Frequency</u>	<u>Transmitted Signal Frequencies</u>	<u>Intermediate Frequencies by Heterodyne</u>	<u>Original Cause</u>
980,000	804,100	175,900	Piccolo
980,000	800,040	179,960	Bass Viol
980,000	800,000	180,000	Carrier
980,000	799,960	180,040	Bass Viol
980,000	795,900	184,100	Piccolo

It might be well for you to prove these figures by the indicated subtractions.

By subtracting the lowest from the highest intermediate frequency produced, you see that a band 8200 cycles wide is required to transmit through the intermediate-frequency amplifier all the frequencies which are necessary to produce at the output of the second detector the range of musical frequencies set up by the instruments listed above.

From the fact that radio stations are allotted a channel width of 10 kc. in the broadcast band it is evident that the intermediate-frequency amplifier must be capable of passing this band of frequencies if successful reception of broadcast programs is to be accomplished.

It is important that we should continue this reasoning into the field of television transmission and reception. Considerably more information must be passed over a television channel than over a sound broadcast channel as the following comparison indicates; a very ordinary television program will use signal frequencies up to 50,000 cycles, whereas 5,000 cycles is sufficient for sound programs. Hence, the width of the television frequency band required is 100 kc. instead of 10 kc. This extremely wide band demands that a television transmission be on some high carrier frequency in order to economize in the use of radio channels. On this account the Federal Radio Commission has licensed experimental stations between 2000 and 3000 kc., which provide a range for 10 stations to operate nearby simultaneously, each on a separate channel 100 kc. wide.

In a superheterodyne receiver for such a signal, the use of a 180 kc. intermediate frequency would be impractical, because the i-f amplifier would have to pass frequencies from 130 to 230 kc. However, we can use a higher intermediate frequency, such as 600, 800, or 1000 kc., and get good amplification of the entire band width of 100 kc.

Note that in this particular design the intermediate-frequency amplifier may pick up considerable interference from the broadcast stations unless special care is taken to exclude such signals.

Selection of the Intermediate Frequency. To return to the problem of broadcast reception, we are concerned with the selection of some value for the intermediate frequency which will not complicate our problem of amplification without interference. Early superheterodyne receivers used between 30 and 45 kc. as the intermediate frequency, but later use was made of 180 kc. It was found that in the case of an intermediate frequency of 180 kc. it was practically inevitable that harmonics of this frequency would exist in some of the circuits. For example, of these harmonics the second would be 360 kc.; the third, 540 kc.; the fourth, 720 kc.; the fifth, 900 kc., and so on. The difficulty encountered here is that the i-f harmonics might combine on the second detector grid with stray radio-frequency signal voltages and due to the heterodyning action undesirable whistles would be heard through the loudspeaker.

The most offending harmonics of the intermediate frequency are the second and third, because they are comparatively strong. From the range of the harmonics just mentioned and the fact that the broadcast band extends from 550 to 1500 kc. it is apparent that the third harmonic of all intermediate frequencies between 183 and 500 kc. and the second harmonic of all intermediate frequencies between 275 and 750 kc. will fall in the broadcast band. Hence, it is difficult to use intermediate frequencies greater than 265 kc. for broadcast reception.

#### Band Tuning of Selector Circuits in Intermediate-Frequency Amplifier.

If every tuned circuit in the i-f amplifying system is tuned exactly to the nominal intermediate frequency, 180 kc. for instance, the sharpness of tuning in so many stages may result in the loss of the side bands representing the high musical notes. Therefore to obtain uniform efficiency from an i-f amplifier it required special care in design which permitted the adjustments required to get a flat-topped

i-f resonance curve. This can be accomplished as follows: The operation consists in tuning one i-f selector circuit to a frequency several kilocycles lower than the nominal intermediate frequency, and tuning another of its selector circuits to a frequency several kilocycles higher. Then with one or more other selector circuits tuned accurately to the intermediate frequency, an over-all resonance curve for the amplifier shows an approximately flat top 10 kc. wide with steep sides.

As just explained a flat-topped i-f resonance curve indicates the desirable condition for uniform efficiency in reproducing all the musical frequencies transmitted, and yet have the proper degree of selectivity against radio programs in the adjacent radio-frequency channels, that is, only 10 kc. above or below the desired station.

#### VOLUME CONTROL.

Whatever methods of volume control are suitable for a straight radio-frequency receiver are also applicable to the radio-frequency amplifying system of the superheterodyne receiver. In addition, the same change in amplifier grid bias voltage which may be used in the radio-frequency section can be applied to the grid bias of tubes in the i-f amplifier. Although the grid bias of i-f tubes can be controlled as just stated it is not good practice to have any wide range of volume control in the i-f amplifier system alone. The reason is because a very strong radio frequency may reach the first detector and cause distortion there, without the second detector being anywhere near overloading, due to the protective effect of the lowered amplification of the i-f system. Therefore, when a single knob is provided to control the grid bias voltages in both the r-f and i-f systems, then a voltage divider system may be used which applies a much greater bias change to the r-f amplifier tubes than to the i-f tubes.

Automatic volume control (AVC) by various methods is extensively used in superheterodyne receivers. In brief the AVC functions by making use of the direct current produced by the rectification of the intermediate frequency in either the second detector or in some auxiliary tube which is added especially for this purpose and, therefore, has no other function. Such a rectified current depends in value, of course, on the amplitude of the intermediate-frequency current. The rectified current, when passed through a fixed resistor, provides a voltage drop which becomes available for volume control just as though the voltage were provided by a manually-operated volume control using a variable resistor and a fixed current.

A fine degree of engineering design in the various constants of the bias control circuits has made this action so automatic that very little change in loudspeaker volume is noticed as the tuning control is varied to bring in stations on different channels and of widely different field strengths at the antenna. A hand control located on the receiver panel allows the listener to adjust the sound volume to whatever general level is pleasing at the moment.

In some receivers a "local-distant" switch is included in the design. In one form of circuit, two resistances are arranged for connecting to the first i-f transformer. At the "local" position the switch connects a 40,000 ohm resistor directly across the primary of this

transformer and a 500 ohm resistor in series with the secondary and one side of its tuning condenser. The effect of these resistors is to decrease the sensitivity, broaden the selectivity and thus improve the fidelity of the receiver. At the "distant" position the resistance is out of both circuits and the original sensitivity and selectivity is obtained.

#### RADIOTELEGRAPH RECEPTION BY SUPERHETERODYNE.

Radiotelegraph or code signals of the damped or otherwise modulated type may be received on any superheterodyne whose radio-frequency selector circuits can be adjusted to pick up the station.

Continuous waves from a code transmitting station require the production of an audible beat note by some method of heterodyning which is independent of the superheterodyne principle. It may be accomplished by either the separate heterodyne or the autodyne methods.

Separate Heterodyne. A second local oscillator consisting of a vacuum tube and tuned circuit may be used to provide a frequency which differs from the intermediate frequency by only a few hundred cycles so that when coupled to the input of the second detector, an audio tone is produced whenever the transmitter is keyed on. This second local oscillator may be made to function at a frequency a few hundred cycles removed from either the original radio frequency or the first local oscillator frequency; the coupling is then into the first detector. Either heterodyne action produces an intermediate frequency which is the same few hundred cycles removed from that produced by the incoming signal and the first local oscillator. These two intermediate frequencies are amplified together, and when they reach the second detector, the audible beat note of a few hundred cycles is extracted.

Autodyne. Either the first detector or the second detector can be made self-oscillatory by ordinary feed-back methods to provide the additional local oscillation required for the audible tone.

Complete Autodyne. This method completely eliminates the necessity for any separate oscillator in a superheterodyne, even for CW reception. The first detector is made self-oscillatory at radio frequency of such a value that the autodyne action results in an intermediate frequency. This is amplified before reaching the second detector which is self-oscillatory at near the intermediate frequency, the autodyne action here producing an audible frequency for translating dots and dashes.

### PRACTICAL APPLICATIONS OF SUPERHETERODYNE PRINCIPLE

#### ELECTRICAL DESCRIPTION OF A TYPICAL SUPERHETERODYNE CIRCUIT.

The schematic diagram of a typical superheterodyne receiver for broadcast reception is shown in Figure 5. Starting from the antenna circuit, we find the following action taking place in the various stages.

The antenna is coupled to the grid coil of the r-f stage by means of a high inductance coil connected from antenna to ground. This in-

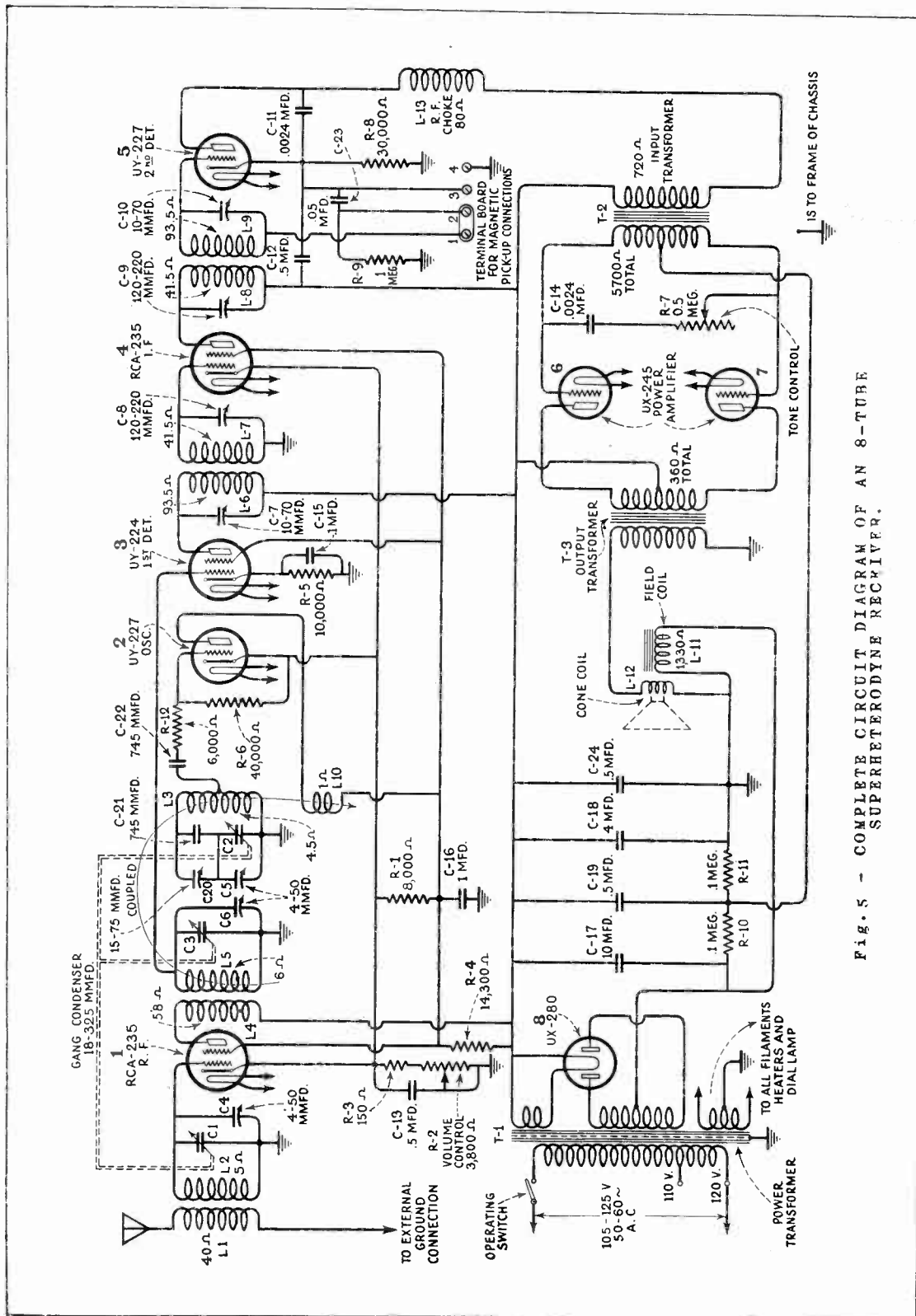

Fig. 5 - COMPLETE CIRCUIT DIAGRAM OF AN 8-TUBE SUPERHETERODYNE RECEIVER.

ductance has a sufficiently high value so that variations in the antenna system have but little effect on the tuning of the adjacent circuit.

The first tube is a tuned r-f stage. This is the super control screen-grid tube type RCA-235, which has a grid potential-plate current curve that has no pronounced "knee". This characteristic reduces the tendency of the tube to become a detector when the control grid voltage is raised by the volume control. Such a characteristic means that secondary modulation effects will not be obtained and distortion due to high signal intensities will not develop. Also, improved volume control action and elimination of the local-distant switch is obtained through the use of this tube. The gain and other characteristics are approximately the same as those of a UY-224. The output of this circuit is inductively coupled to the grid coil of the first detector.

At this point the oscillator should be considered as its output is also coupled inductively to the grid coil of the first detector. This is a tuned grid circuit oscillator using a UY-227, and having a closely coupled plate coil that gives sufficient feed-back to provide stable operation. The grid circuit is so designed that by means of a correct combination of capacity and inductance a constant frequency difference between the oscillator and the tuned r-f circuits throughout the tuning range of the receiver is obtained.

The next circuit to examine is the first detector. The circuit is tuned by means of one of the gang condensers to the frequency of the incoming signal. In the grid circuit there is present the incoming signal and the oscillator signal, the latter being at a 175 kc. difference from the former. The first detector is biased so as to operate as a plate rectification detector and its purpose is to extract the difference or beat frequency, produced by combining the signal and oscillator frequencies. The beat frequency—175 kc.—appears in the plate circuit of the first detector which is accurately tuned to 175 kc. The tube used as a first detector is a UY-224.

The next stage is that of the i-f amplifier. A single stage is used. This requires two i-f transformers consisting of four tuned circuits. The plate circuit of the first detector, the grid and plate circuits of the i-f amplifier and the grid circuit of the second detector are all tuned to 175 kc. The transformers are peaked, no attempt being made for flat top tuning. An RCA-235 tube is used in this stage and its control grid voltage is also varied by means of the volume control.

The second detector is a high-plate voltage, grid-biased type using a UY-227, which gives sufficient output to drive two UX-245's connected in push-pull without an intermediate audio stage. The purpose of the second detector is to extract the audio-frequency component of the r-f signal which represents the voice or musical modulations produced in the studio of the broadcasting station. The audio component is extracted and used to drive the power tubes while the r-f current is by-passed and not used further.

A filter circuit consisting of a 0.05 mfd. condenser and 1 megohm resistor is used in the second detector grid circuit. This further reduces the small a-c hum voltages present in the detector stage.



The power a-f stage consists of two UX-245's connected in push-pull. Transformer coupling is used between the detector and the grids of the UX-245 tubes as well as from the plates to the cone coil of the reproducer unit.

A tone control, consisting of a 0.0024 mfd. condenser in series with a 500,000 ohm variable resistor connected across the two grids of the UX-245 tubes is incorporated in this stage. The tone control functions to reduce the high-frequency output as the resistance is reduced. At the extremely low position, the condenser and secondary of the a-f transformer resonate at a low frequency and thereby further accentuate the bass response, thus partially compensating for the lack of a large speaker baffle surface.

The direct plate and grid voltages used by all the tubes are supplied from high voltage alternating current which is rectified by means of a UX-280. The filter used is of the "brute force" type using the field of the reproducer unit as the reactor. Electrolytic type condensers of 10 and 4 mfd. capacity respectively are used before and after the reactor. Two 0.5 mfd. condensers in the filter circuit function to by-pass any r-f current that may be present. The bias voltage (45 volts) for the UX-245 tubes is obtained by using half the voltage drop (90 volts) across the field coil of the reproducer unit. Two 100,000 resistors shunted across the field act as the voltage dividing resistor for this bias voltage.

#### CIRCUIT DESCRIPTION OF A PORTABLE TYPE SUPERHETERODYNE.

Another practical application of the superheterodyne principle is illustrated in the portable superheterodyne receiver designed for dry-battery operation. Figure 6 shows a schematic diagram of this portable type receiver. The r-f pentode tube, type RCA-234, is employed in the r-f and i-f amplification and second detector stages.

As in other pentodes, this tube utilizes an additional grid or suppressor which is located between the screen grid and the plate and serves to minimize the effects of secondary emission. The added element is connected inside the tube to the filament. As an amplifier, this pentode is effective in the reduction of cross-modulation and of modulation distortion throughout the entire broadcast-frequency band and permits easy control of a moderate range of signal voltages without the use of a local-distant switch.

The second detector serves to furnish grid bias voltage variation to the r-f and i-f amplifiers with incoming fluctuations of signal strength. The second detector thereby provides an automatic volume control feature in addition to its primary function and thus permits the elimination of the additional "control" tube.

In this system, the entire i-f signal input in series with a large fixed resistance is impressed between the plate and filament of the second detector. These elements function as a diode rectifier. The low-potential end of the i-f transformer secondary winding thus assumes a negative polarity with respect to ground which is applied to the grids of the r-f and i-f amplifiers. The audio-frequency modulation also appears across two resistors in the rectifier circuit and is capacitance-coupled to the control grid of the second detector. The screen grid of that tube functions as the customary plate and is impedance coupled to the grid of the first audio-amplifier. The

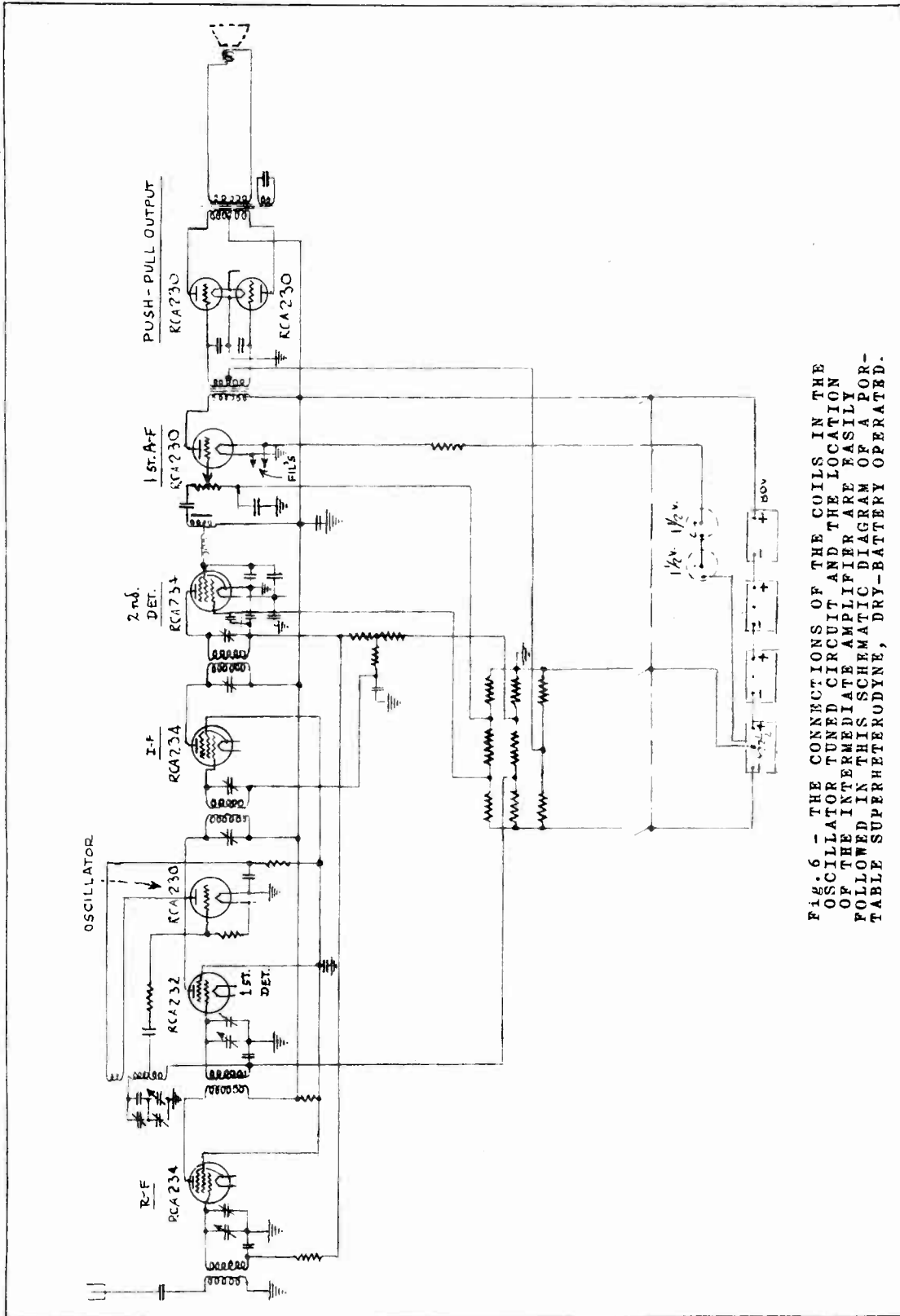

Fig. 6 - THE CONNECTIONS OF THE COILS IN THE OSCILLATOR TUNED CIRCUIT AND THE LOCATION OF THE INTERMEDIATE AMPLIFIER ARE EASILY FOLLOWED IN THIS SCHEMATIC DIAGRAM OF A PORTABLE SUPERHETERODYNE, DRY-BATTERY OPERATED.

manual volume control serves, as a potentiometer, to vary the audio-voltage impressed on the latter tube and thus permits adjustment of the audio output to the desired level. The audio-amplification system consists of a single driver stage transformer-coupled to a class "B" operated power output stage. The use of class "B" amplification permits of extremely economical "B" battery operation since the output tubes are biased approximately to cut-off and normal plate current flows only when modulated signals are being received. The plate current is at all times only the audio-component of the signal which feature provides a power output of at least four times that obtainable from the same tubes working at the same voltage but in the conventional manner. Note in this circuit that objectionable high-frequencies generated within the power stage are minimized by means of a filter circuit consisting of an additional output transformer secondary winding shunted by a fixed capacitor.

In regard to practical operation observe that bias voltages for all tubes except the oscillator are obtained from three voltage-divider systems connected in parallel across the first 22.5 volt section of the "B" battery. The oscillator in this arrangement is self-biased

#### EXAMINATION QUESTIONS

1. What is an advantage of radio-frequency amplification?
2. Can radio frequencies above 300 kc. be amplified as successfully as at lower frequencies?
3. What are the principal parts of a superheterodyne circuit?
4. Explain briefly the principle of the superheterodyne.
5. What is the function of an intermediate transformer?
6. What is the purpose of the first detector?
7. Why is 175 kc. better than 190 kc. for the intermediate frequency?
8. What is the function of the second detector?
9. What is the function of the local oscillator?
10. How would the program sound if the local oscillator suddenly changed its frequency by 5 kc.?

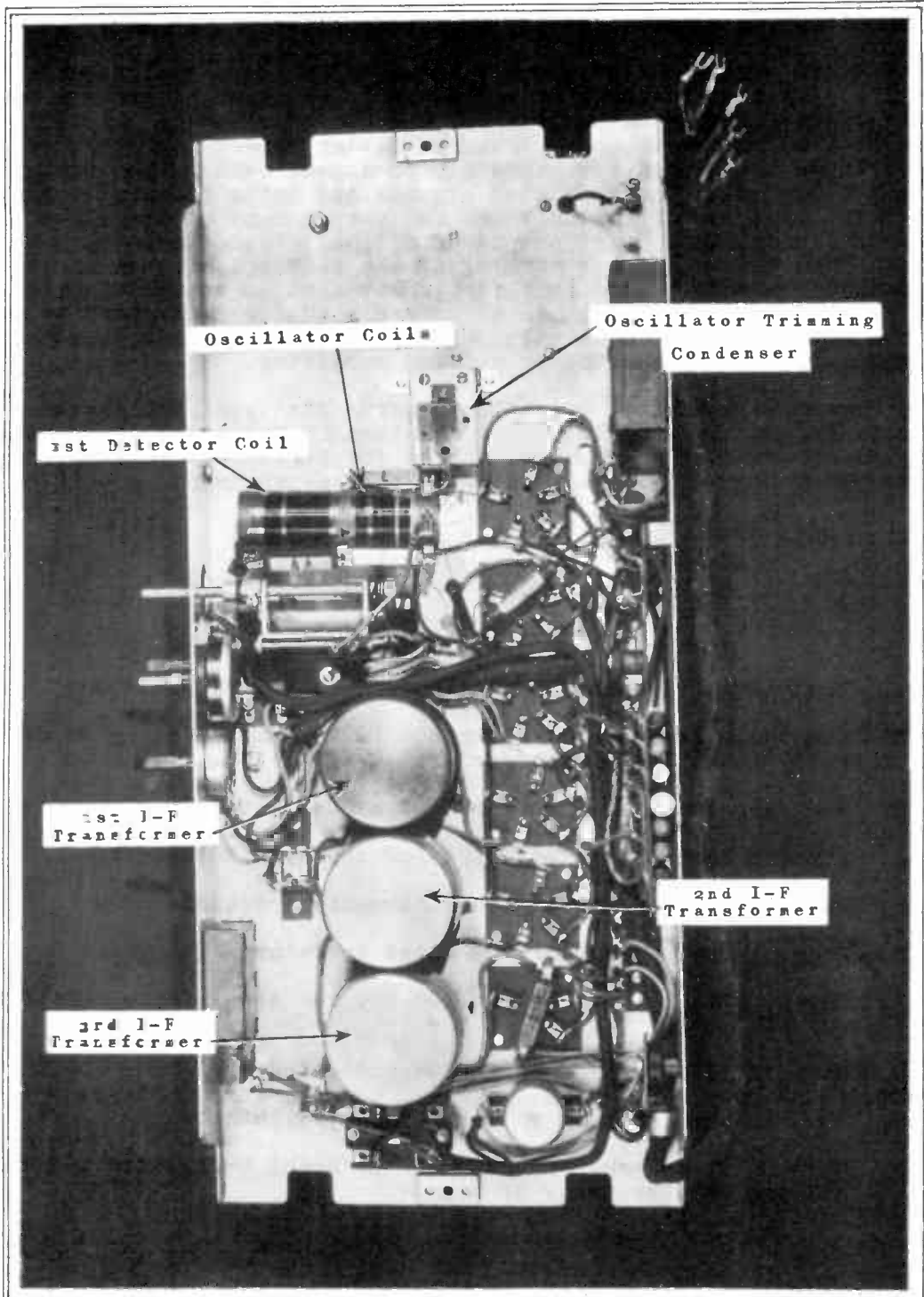

SUB-CHASSIS VIEW OF A TYPICAL SUPERHETERODYNE RECEIVER ASSEMBLY SHOWING LOCATION OF OSCILLATOR AND 1ST DETECTOR COILS, AND SHIELDED INTERMEDIATE-FREQUENCY TRANSFORMERS.