

# NATIONAL RADIO INSTITUTE

Complete Course in  
**PRACTICAL RADIO**

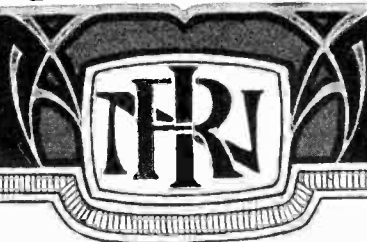

**Radio-Trician**

(Trade Mark Reg. U. S. Patent Office)

*Lesson Text No. 8*

(2nd Edition)

**FUNDAMENTAL**

**A C**

**THEORY**

Originators of Radio Home Study Courses  
... Established 1914 ...  
Washington, D. C.

"The only road, the sure road—to unquestioned credit and a sound financial condition is the exact and punctual fulfilment of every pecuniary obligation, public and private, according to its letter and spirit."—Rutherford Birchard Hayes.

### SOME GOOD STUDY HABITS

A Personal Message from J. E. Smith

Speed. Attention is called to the fact that habit increases the speed of work. The question here is how to get up speed in doing mental work and at the same time avoid errors. Most persons have a certain gait at which they can do the best work. Try to add a column of figures very, very slowly. See how slowly you can do it. Note the number of mistakes you make. Now do it as fast as you can and count the mistakes. Both times you make more mistakes than you would by working at your natural speed. This natural speed is a matter of habit; it is not fixed by nature.

Speed of thinking is not altogether a gift; it is an achievement as well. There are some minds that work faster than others, true enough. But these individual differences in speed can be traced to habit. All our minds will work faster than we think they will; they only need speeding up. How can this be accomplished? By working right up to the speed limit all the while. The main reason why you work slowly is that you have never consistently tried to work faster. Or perhaps, you have not tried in the right way. To accomplish speed in mental work, two things must be observed. First, do not increase the speed too much at once. Go at it gradually. Second, learn short cuts and new tricks. The lightning calculator performs his "stunts" by applying certain established mental habits. The chances are that he is no more "gifted" than you are. The difference is that he has worked at it and you have not. You, too, with the right amount of practice in the right direction, could become a lightning calculator. It's all a matter of habit.

Copyright 1929, 1930  
by  
NATIONAL RADIO INSTITUTE  
Washington, D. C.

# Radio-Trician's

(Trade Mark Reg. U. S. Patent Office)

## Complete Course in Practical Radio

NATIONAL RADIO INSTITUTE

WASHINGTON, D. C.

---

---

### FUNDAMENTAL A. C. THEORY

We have now come to the point where we shall have to begin studying the difference between **direct current** and **alternating current** and the action of each in radio circuits.

#### DIRECT CURRENT

There are two kinds of electric current used in Radio, first, **direct current** (D. C.) such as furnished by storage batteries, dry cells, or dynamos, and the second kind is **alternating current** (A. C.). Direct current is one which always flows in the same direction through its path, as, for example, the flow of water from a spring, through the brook, the river, and into the ocean. Another example is shown in the top of Figure 1, where we show a centrifugal pump C, which keeps a steady flow of continuous or direct current in the pipe B. This water flows in the same direction at all times. So it is with the flow of direct current electricity. It always leaves one part of the source of power and flows along the wire in a fixed and definite direction at all times.

This particular type of electricity is most efficient for certain classes of work as, for example, the driving of small electric motors, operation of electromagnets, applying high voltage direct current to the plates of vacuum tubes, for charging storage batteries, and electrical chemical processes, etc.

#### ALTERNATING CURRENT

As the word signifies, it is a flow of current which changes its direction, alternating first in one direction, and then reversing to the opposite direction, going through these changes a certain number of times during each second. One might get a clear understanding of this reversing motion by referring to a water pumping system such as illustrated in the center of Figure 1. Here we have a cylinder with a pipe line connecting at either end which supplies the water by the action of a piston, this piston moving back and forth within the wall. One can readily see that

the flow of water in the main pipe "A" would be continuously reversing in its flow. The curved line at the bottom of this figure shows the change in value and direction for the alternating current flow for one complete change of current. This is called a cycle, which is one complete operation.

Let us now look at this action from another point of view; if you were in a room 18 feet wide and you started to run from one side of the room, and then after you passed the center of the room, you began to slow down and stopped at the other wall, and turned around and ran back in the other direction, you might repeat this operation many times, this would represent an alternating motion of travel and this would correspond very nearly to the flow of an alternating current.

Let us think of alternating current in comparison with the flow of water through a pipe line which is connected to a plunger type of pump, where the piston goes back and forth in a cylinder as illustrated in the middle Figure 1.

Now you can readily see by looking at that diagram that the piston passes from one end to the other, therefore, the water will begin to flow through the pipe in one direction, and when the piston reaches the end of the pump and stops for a moment, the water will stop flowing and, therefore, the flow will reach a zero value. And when the piston comes back on the return stroke, the water will be forced in the opposite direction in the pipe line. This is the correct way to look at it instead of looking at it as falling below the zero value. In other words, alternating current flows in one direction, then stops and flows in the other direction.

↳ Alternating currents of from 25 to 60 cycles per second are used for industrial purposes, while the frequencies of current used in Radio communication range all the way from around 15,000 to 150 million cycles per second. To simplify the figures used, the word "kilo" is used to represent 1 thousand, for instance, 100,000 cycles is referred to as 100 kilocycles.

We will now review some of the things we learned in our "bird's-eye view" of the first six lessons to refresh our memory before we take up the subject of **Electromagnetic Induction**, etc.

## MAGNETS AND MAGNETISM

### Kinds of Magnets.

A natural magnet is, as you have learned, a piece of ore (a natural substance containing a mineral) that has the property

of attracting pieces of iron, steel and a few other metals. This ore was first discovered in the Province of Magnesia, Asia Minor. The peculiar property was, therefore, called magnetism and the name magnet was applied to a piece of ore possessing this property.

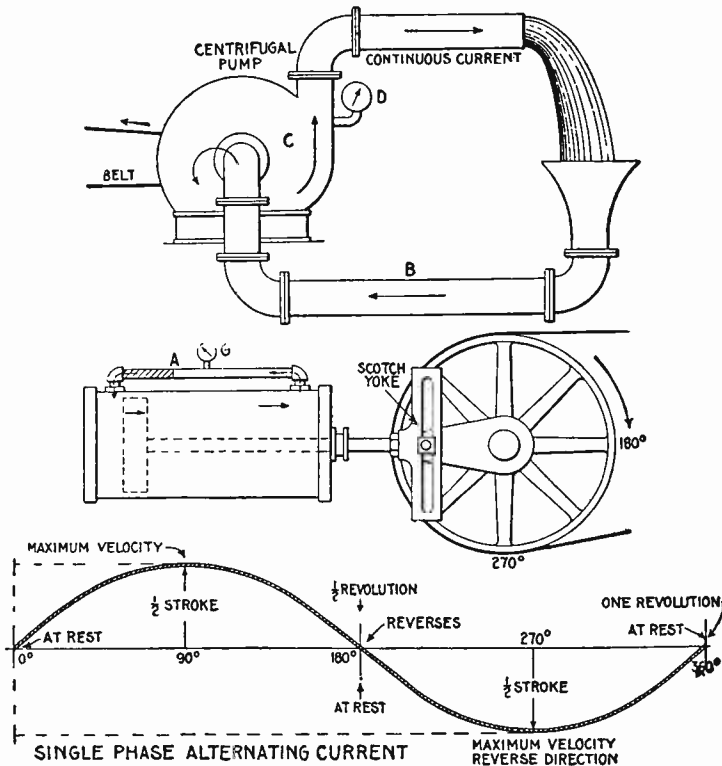

Fig. 1—This diagram illustrates the difference between direct and alternating current. In the above diagram a centrifugal pump C forces water to the upper pipe, from which it falls by gravity to the lower pipe B and re-enters the pump. The water is continuous, always flowing in one direction, that is, it does not reverse its direction. Similarly a direct electric current is constant in direction, though not necessarily constant in value. The center diagram illustrates a double acting cylinder with the ends connected by a pipe A and the piston driven by a crank and a Scotch yoke. If the cylinder and pipe is full of water, a current will flow through the pipe in the direction of arrow as the piston begins its stroke increasing to maximum velocity at one-quarter revolution of the crank, decreasing at one-half revolution, then reversing and reaching maximum velocity in the reverse direction at three-quarters revolutions, and coming to rest again at end of return stroke. If a pressure gauge is inserted as shown in the diagram marked G it will measure a pressure which varies with the current of water. Since alternating electric current undergoes similar changes this simple illustration will explain the single phase alternating current as shown in bottom diagram, which will apply equally as well to the pump cycle as to alternating current cycle.

Later the discovery was made that if such magnets were suspended so they could turn freely, all would come to rest in a position pointing North and South. Small bars of the ore were thus used to guide ships over the sea. They were, therefore,

called lodestones (leading stones), a name that is also applied to the ore. These lodestones were thus the forerunners of the modern compass.

### Bar Magnets.

A small rod of iron or steel which is brought near to a piece of lodestone, or which is rubbed on it in a certain way, shows the same properties and is said to be magnetized. If the rod or bar is made of rather hard steel, the effect persists after the lodestone has been taken away, and the magnetized rod is then called a permanent magnet, or simply a bar magnet. These permanent magnets may be made in the form of straight bars of round or square sections, usually with the length rather large as compared with the diameter. They are also often bent in various shapes, a common form being the horse-shoe or U shaped magnet.

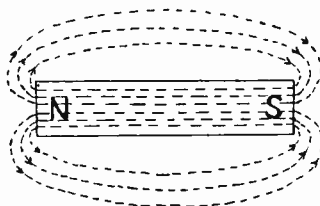

Fig. 2—Distribution of magnetic field around a bar magnet.

Magnets may also be made by passing an electric current through a coil of insulated wire which surrounds the rod. If the rod is made of soft iron, it is only magnetized as long as the current flows. It is then called a temporary magnet, or an electromagnet. Examples of electromagnets are seen in induction coils and buzzer cores, in telegraph sounders and in telephone receivers. Electromagnets are very useful because the magnetism is so easily controlled by variations in the current strength. If the bars are of hardened steel, the magnetism due to the current remains after the current ceases and a permanent magnet is the result.

### The Magnetic Field About a Current.

It has already been pointed out in our "bird's-eye view" that there is a magnetic field about a wire in which a current is flowing. Experiments with a compass show that this magnetic field has lines of force in the form of concentric circles about the wire. These circles lie in planes at right angles to the axis of the wire. If the wire is grasped by the right hand with the

thumb pointing in the direction of the current, the fingers will show the direction of the magnetic field as shown in Fig. 3.

### The Solenoid and the Electromagnet.

If the wire which carries a current is bent into a circle, the magnetic field is of the form shown in Figure 4. If many turns are wound close together in, what may be called, a bunched winding, the intensity of the magnetic field is increased in direct proportion to the number of turns. When the wire is wound

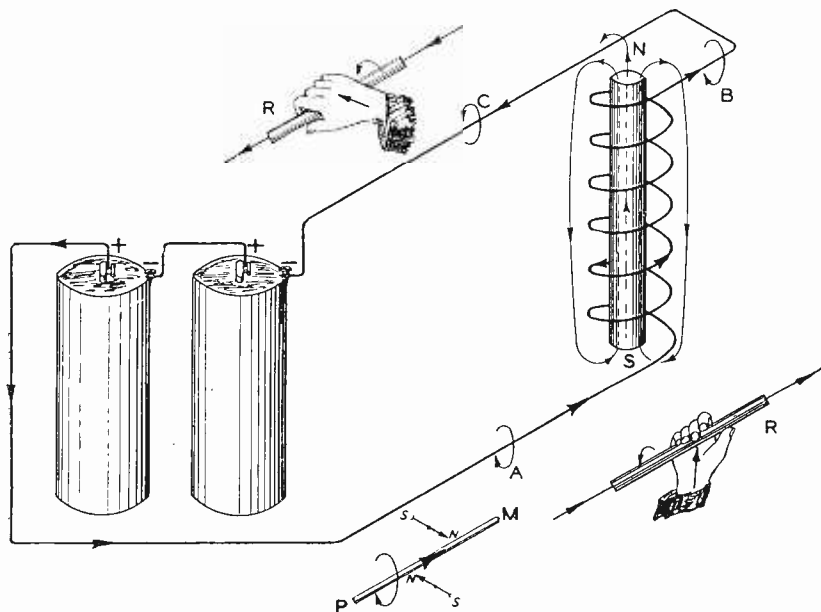

Fig. 3—Illustrating the direction of current and magnetic field using the right-hand rule.

closely with many turns, side by side along the surface of a cylinder in a single layer, the coil is called a solenoid. In this case, the magnetic field is nearly uniform for a considerable distance near the center of the coil, and the solenoid has the property of a bar magnet. This can be clearly seen by observing the magnetic fields of Figure 2 and Figure 5. The intensity of the field and the density of the magnetic lines within the solenoid depend entirely upon the strength of the current and the number of turns of wire. The same magnetizing effect can be secured with many turns and a weak current, or with a few turns and a strong current, provided only that the product of wire turns times amperes of current is the same in each case. This product is called the ampere-turns.

34

4 If the space within the solenoid is filled with iron, the magnetic lines are very greatly increased. This is due to the property of iron called magnetic permeability. To say that iron is more permeable than air means that the magnetism is stronger when iron is present than it would be if the space were filled with air alone.

It can be clearly seen that when a direct current flows through a coil, it acts exactly like a magnet and will attract iron in the same manner, but as soon as the current is cut off, the



Fig. 4—Magnetic field about a single loop carrying current.

attraction ceases. While the current flows, a magnetic field is produced—that is, the space inside and around the coil is full of lines of force, which are as shown in Figure 5. These lines of force are strong inside the coil and spread out in all directions around it. When the current flows in one direction, the North Pole is at one end of the coil and the South Pole at the other.

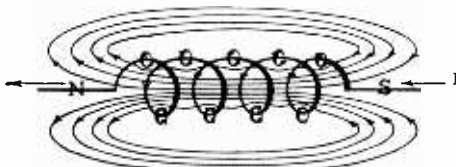

Fig. 5—The total magnetic field of a solenoid (inductance coil) carrying current.

The polarity of a coil of wire carrying a direct current can be found by the end rule (sometimes called the corkscrew rule), that is, looking at the end of the coil, if the current is flowing into or out of the end turn in a counter-clockwise direction, that end is the North Pole of the coil (see right-hand side Fig. 6); if in a clockwise direction, it is the South Pole (as shown at left, Fig. 6).

Therefore, when the current flows in the opposite direction, the poles are reversed so that when alternating current is applied to the coil, the direction of the field is constantly changing at the frequency of the alternating current.



Now that we have learned a great deal about solenoids and electromagnets, let us turn our attention to **Electromagnetic Induction**.



**HANS CHRISTIAN OERSTED—1777-1851**  
Professor of Natural Philosophy in the University of Copenhagen, 1820, accidentally discovered that a wire through which a current was flowing had the power of deflecting a near-by compass needle. In other words, when an electric current flows through a wire or coil "magnetism" will be made.

## **ELECTROMAGNETIC INDUCTION**

In the following pages, we will learn how a current can be generated in a coil of wire if that coil of wire is moved in a magnetic field. In the year 1831, Michael Faraday discovered the principle of electromagnetic induction. In one of his experiments, he wrapped a coil of wire about a block of wood and con-

5

nected the terminals to a galvanometer (an extremely sensitive instrument used for detecting and measuring electric current and also for indicating the direction of the current in a circuit). Another coil was wrapped around the first one and connected to a battery. He found that upon closing the circuit of the coil in series with the battery, that the needle of the galvanometer was momentarily deflected, and upon opening the circuit, that the needle again deflected, but in the opposite direction.

This experiment opened up a new field of investigation in electrical science and the principle deduced from it is of great importance, due to it being the basic principle of the production of electricity by mechanical motion. There is an interesting experiment in this connection which is pictured in Figure 7. A small sensitive voltmeter is connected to a solenoid (coil of wire)

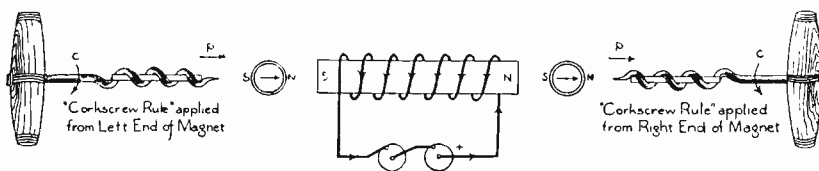

Fig. 6—Showing the application of the "corkscrew rule for solenoids" to a magnet.

which is formed by winding a piece of wire around a cardboard cylinder. If we were to take a permanent magnet in our hand and move it up and down in the solenoid, we would find that the voltmeter would register, proving that an E. M. F. (voltage) has been produced in the coil. What if we were to hold the magnet still? Would a current be produced? Not at all, we cannot fool nature. There is an inflexible law that states work must be done to create energy. This is the law of conservation of energy. We could hold the magnet still in the center of the solenoid, but we would find that no voltage would be generated. If we move the magnet up and down, however, the voltmeter will register faithfully, and we will see that the needle of the voltmeter would jog back and forth following the movement of the magnet. When we move the magnet in one direction, and then move it back in the opposite direction, the current will reverse.

Here we have in a nut-shell the principle of the generation of the electrical power that is used today. This same principle applies to the generation of radio currents in your receiving antenna. Will the generated current in the solenoid depend upon the power in the magnet? Yes, it will. It will depend upon the

power of the magnet and the speed with which we move the magnet. If we move the magnet rapidly, we cause more work to be performed and the current generated will be greater. We might put it this way. The strength of the current flowing in the solenoid will depend upon the number of lines of force cut by the solenoid per minute. We use the word "cut" here in rather a peculiar way. Of course, we could not cut the lines of force with a knife or even with a good safety razor blade in the generally accepted sense of the term.

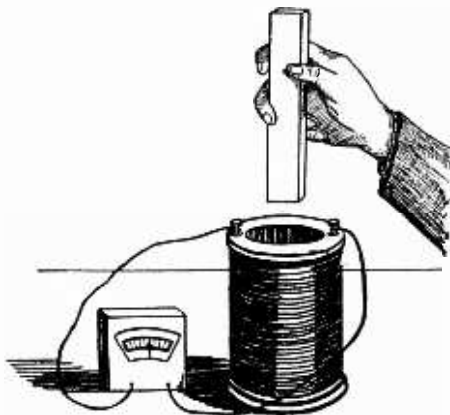

Fig. 7—Electromagnetic Induction, using a coil of wire, magnet and voltmeter.

There is another interesting experiment illustrated in Figure 8. Here we have two independent electrical circuits. If you trace out the two circuits, you will notice that one circuit contains a small key or switch, a solenoid and a dry cell. The other circuit contains another solenoid larger than the first and a small voltmeter. This small solenoid fits within the large one. If we close the circuit with the switch and place the small solenoid within the large one, we will notice that the voltmeter needle will move, proving that there is an electromotive force (voltage) produced in the second circuit. This should be easy to understand. It is simply another case of electromagnetic induction. The small solenoid will generate a concentrated magnetic field when a current is flowing through it, and these magnetic lines of force will cut the second solenoid and a current will be produced in the second circuit. If the small coil is allowed to run

slowly in the center of the large one, current will be generated only at the moment the key is pressed and the magnetic lines of force spread outward. If the circuit is kept closed, a current will be produced in the larger coil if we keep the smaller coil moving. Therefore, the three ways a current can be induced in a coil of wire are:

- (1). By moving a magnet inside a coil of wire and connecting the two ends of the coil together, a current of electricity will flow through the coil.
- (2). By replacing the magnet by a coil of wire through which a current is kept flowing and making this coil move inside another coil of wire; the effects then produced are known as those of mutual induction.
- (3). By leaving one coil inside of the other and making and breaking the battery circuit by means of a switch.

In the last two cases, the battery circuit is called the primary and the coil in which the current is induced is called the secondary.

The point to remember here is this: The magnetic lines of force have to be constantly moving about or around the wire or coil. Note that in the first case mentioned, the moving magnetic lines cause the lines to cut the wire.

We readily recognize the second case is using the same principle as that of the first case, only here we use an electromagnet in place of a permanent magnet of steel.

What would happen if we had the magnet stationary and moved the coil? Again, we would have a current induced in the coil showing that the magnetic lines were being cut.

So far, so good. But what about the third case? Here the coils are not moving. Why should we get an induced current in the coil now? Of course, you have the answer. In testing electromagnets, you would observe that when a current stopped flowing, then the magnetic lines would cease to exist. Thus, when the current was made in the electromagnetic coil, magnetic lines moved and extended outward which cut the secondary coil. Again, as the current was broken in the magnet, the lines collapsed, causing the lines to cut the coil in the opposite direction. This caused the induced current to flow in one direction as the primary current was made, and then the induced current flowed in the opposite direction when the primary current was broken. Thus, the induced current was found to be an alternating current. It is called an "alternating current" because it alternates

**in its flow of direction.** This third method is the underlying principle for the operation of all radio and audio frequency transformers in radio receivers.

In the little experiment shown in Figure 8, we use **direct current.** What if we had taken the battery out of the circuit and



MICHAEL FARADAY—1791-1867

Who discovered the principle of electromagnetic induction.

replaced it with an **alternating current** generator? Now put on your thinking cap. What would happen? Think hard. We know that an alternating current falls to zero a number of times each second, and if the current falls to zero, then the magnetic field must collapse with it and rise with it when the current builds up again. We picture, then, an alternating magnetic field

as having a sort of a breathing effect. It rises and falls like the waves of the ocean. In other words, it is constantly in motion, where the magnetic lines of force produced by a direct current are at rest after they are once produced. If there is an alternating magnetic field about the little solenoid, the larger solenoid will constantly cut through these magnetic lines of force, or we might say, the magnetic lines of force will cut through the big solenoid and current will be generated in it. This is the principle of electric transformation upon which all electrical transformers operate.

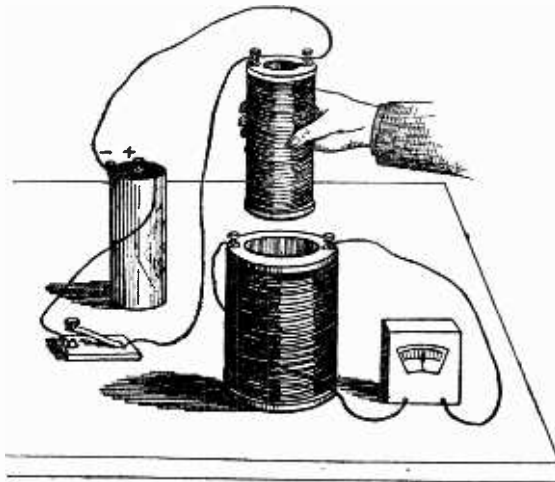

Fig. 8—Electromagnetic Induction.

Could there be such a thing as a direct current transformer? Surely you would not make the sad mistake of saying that there could be. If we wish to use this principle of transformation with a direct current, it would be necessary to interrupt the direct current many times per second so that the lines of force would be constantly expanding and contracting, building up and collapsing.

Let us refer again to Figure 8. The first circuit which contains a small coil would be called the primary circuit. The second circuit would be called the secondary; the primary circuit then always contains the original current and the secondary circuit contains the induced or transformed current. Nothing confusing about that, is there?

It was noted in the Experiment, Figure 7, that when the magnet was thrust into the solenoid, the current generated in

the solenoid flowed in one direction, and when the magnet was removed from the solenoid, the current flowed in the opposite direction. Now, if instead of thrusting a magnet or electro-magnet in and out of a solenoid, we rotate a coil of wire within a magnetic field as in Figure 9 so that the lines of force of the magnetic field pass through the coil of the rotor first in increasing numbers as when the magnet was thrust into the coil, and then in decreasing numbers, as when the magnet was removed from the coil, we will have generated in the rotor a voltage which causes a current to first flow in one direction and then in the other.

Figure 10 will greatly aid one in understanding the simple principles involved in the production of direct current. The current is taken off from the coil of wire (which rotates between the North and South poles of the magnet) by the use of a device

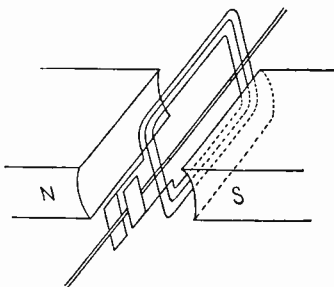

Fig. 9—If we rotate a coil of wire within a magnetic field an alternating potential will be set up in the coil. This is the basic principle of the alternating current generator.

known as a **commutator**. This is really a rotating conductor making contact with the stationary parts called **brushes**. These brushes are the real terminals of the generator and are connected to the outer circuit. The revolving coil in a generator of this type is referred to as an **armature**. The magnet is called the **field magnet** since it is depended upon to produce the magnetic field through which the armature rotates.

Upon what will the voltage and current of this small generator depend? A little thought and you can readily see that the voltage and current will depend upon (1) **the strength or density of the magnetic field between the N and S poles**, (2) **size and number of turns of wire on the armature**, and (3) **speed with which the armature revolves**. X8

The generator shown in Figure 10 is of the simplest type. Larger and more efficient current generators are always pro-

vided with what is known as a field winding. Generators with field windings do not have permanent magnets. In place of permanent magnets, soft iron is used and the field windings are placed over this iron mass.

Do not make the mistake of thinking the above description covers all types of direct current generators used. There are several different types and designs used for various purposes. For instance, the commutators of all but the simplest types, are made up of a number of copper segments in place of the two shown in Figure 10 and instead of one independent coil, there are a number of coils connected to the segments.

This simple explanation of a small direct current generator that is capable of producing direct current should be clearly understood by the student and at the same time it must be remembered that this simple device does not produce direct current in the sense of a battery. That is, the current produced, although it is in the same general direction, is not of uniform value. It will be seen that every time the brushes come to a break between the segments, there will be an interruption. In other words, the current does not change its polarity, but it falls back to zero in every revolution. By increasing the number of coils on the armature and the number of segments, and by providing the field with a pole to match each coil, we can produce a voltage or a series of voltages that have a tendency to build up a fairly uniform value. The little variations are known as ripples and for all ordinary purposes the voltage may be looked upon as uniform.

Now, if we wish to change our simple direct current generator into an alternating current generator, it is only necessary to alter one part—that is the commutator. In place of the two segment commutator, we use two independent metal rings each attached to one terminal of the armature coil, as illustrated in Figure 11. The brushes would make contact with these rings. Under certain conditions, there would be two complete reversals of the current at each revolution of the armature. It can be clearly seen then that the frequency of such a generator would depend not only upon the speed of the armature, but upon the number of coils in the armature and the number of poles in the field of the generator. By providing the generator with two field coils and four poles, the frequency would be doubled at the same speed. Alternating current generators operate on the same principle as direct current generators—that is, currents are pro-



duced with armature coils that cut through magnetic fields. Broadcasting stations use several types of generators, low voltage A. C. or D. C. for tube filaments and a high voltage D. C. for grid and plate supplies or an A. C. generator.

## MUTUAL INDUCTION

The subject of **mutual induction** will now be considered. By this time, we must have come to understand that this subject of induction has many ramifications or divisions into branches,

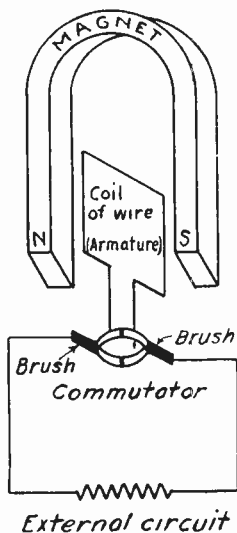

Fig. 10—D. C. dynamo principle. The D. C. dynamo is nothing more or less than a coil of wire moving in a magnetic field provided with a commutator and brushes for leading the current away from the coil.

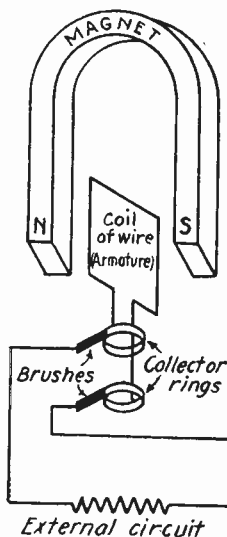

Fig. 11—A. C. generator principle. The above is the same as the dynamo except the commutator arrangement is different. This machine employs two collector rings and brushes.

and that the thing taken as a whole is simple enough. The laws are by no means difficult to learn. When two electrical circuits are close to one another, the current flowing in one will be induced into the other. This is called mutual induction. Mutual induction is easy enough to understand if you have followed the foregoing subjects closely and progressively. A study of the definition of the word "mutual" is apt to fix this clearly in your mind. "Mutual" means "reciprocal" or, in other words, it is a term which describes the act of giving and taking interchangeably. All of us have at some time or other made a mutual agreement. Likewise, then, when we speak of mutual induc-

tion, we refer to the making of electric pressure from one circuit into another circuit interchangeably. Of course, we know now that this is done through the medium of magnetism.

## THE ALTERNATING CURRENT TRANSFORMER

A very important application of the principle of mutual inductance is the alternating current transformer. The transformer is a device for securing mutual induction between two circuits; in some cases, the purpose of using a transformer is to change or transform alternating current of low voltage and large current to alternating current of high voltage and smaller current or vice versa. A transformer used to deliver an output of higher voltage than the input is called a **step-up transformer**. A transformer used to deliver an output of lower voltage than the input is called a **step-down transformer**. For example: To increase the voltage of a 60-cycle current from 110 volts to 220—

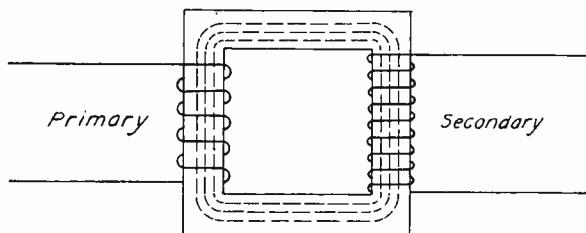

Fig. 12—Step-up iron core transformer.

in other words, we wish to multiply our voltage by 2, therefore, we must have twice as many turns in the secondary winding as in the primary winding or a ratio of 2 to 1. If we desire to triple the voltage, the ratio would have to be 3 to 1, etc.

It can be seen from the foregoing paragraph that the change between the voltage and amperage in the primary circuit and the voltage and amperage in the secondary circuit depends on the turn ratio of the windings, that is, on the ratio of the number of turns in the secondary winding to the number of turns in the primary winding.

The ratio of the secondary turns to primary turns is the same as the ratio of secondary volts to primary volts. In other words, if we have ten times as many turns in the secondary winding as in the primary, we will have ten times as many volts in the secondary as in the primary. If we have one-half the number of turns in the secondary as in the primary, then the secondary voltage will be half that of the primary voltage.

Since the power must be the same in both of the windings, an increase of secondary voltage means a decrease in secondary amperage, while a decrease of secondary voltage will mean an increase of secondary amperage. For example, suppose we start with 100 watts of power and assuming the primary circuit to carry this 100 watts at 20 volts and 5 amperes, let us see what will appear in the secondary with different turn ratios. Suppose the transformer has twice as many turns on its secondary as on its primary, and the primary voltage is 20. The secondary voltage at a ratio of 2 to 1 will be 40. The secondary power must be the same as the primary power, therefore, the number of amperes in the secondary will be 100 watts divided by 40 volts or  $2\frac{1}{2}$  amperes. If we were using a step-down transformer and there were 6 primary turns and 3 secondary turns so that the ratio of the primary to the secondary would be  $\frac{1}{2}$ , since the primary voltage is 20 and the ratio is  $\frac{1}{2}$ , the secondary voltage

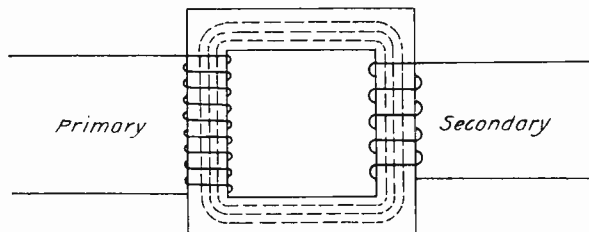

Fig. 13—Step-down iron core transformer.

must be 10. The number of watts in the secondary will be the same as in the primary 100, therefore, the secondary current will be 10 amperes since 100 watts divided by 10 equals 10.

It is evident that we cannot increase both the current and the voltage for here again we would be interfering with the law of conservation of energy. We must not forget that as we increase the voltage and the current, we increase the power, for voltage times amperes equals watts. If we increase the voltage, we must decrease the amperage; and if we increase the amperage we must decrease the voltage. In other words, we cannot get something for nothing.

Transformers are used for many purposes in both electricity and radio in general. Perhaps one of the most important functions in the workaday world of electricity is that of boosting voltage over long distance transmission lines. By using a high pressure, the line losses are reduced and it is possible to use smaller conductors.

The use of power lines for transmission of radio signals is sometimes found throughout the country, known as wired wireless.

For commercial use, this system has certain advantages, such as lack of interference which makes its use valuable, but it is unlikely that the system will ever replace broadcasting. The number of different stations that can be tuned in by using this system is naturally limited, and this is a definite disadvantage.

The system actually differs very little from that of ordinary broadcasting, the major difference being that the power of the transmitter, instead of being radiated into the air by means of an antenna is coupled directly to the power lines. The coupling between the transmitter and the power line is generally made through high voltage coupling condensers and special filter and protective circuits. At the receiving end, an ordinary radio

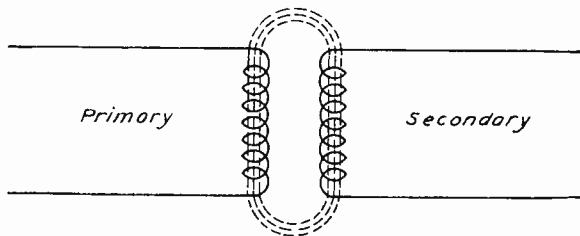

Fig. 14—Air core transformer.

receiver can be used to detect the signals. It also must, of course, be coupled in some way to the transmission line.

The electric light companies all use power transformers for home lighting. The current is distributed over transmission lines at a very high pressure. It is then tapped off through the secondary of the step-down transformer and delivered to the customers at 110 to 220 volts as a rule. Small sizes of power transformers such as are used in battery chargers, A and B eliminators, A. C. receiving sets, and other power supply devices are attached to the 110 or 220 volt line to step up or step down the voltage according to what apparatus is to be operated from it.

In nearly all power transformers in use for electrical transmission of power, the wire for both coils of the transformer is insulated, and there is additional insulation between the two coils. In most cases, the coils are wound so they have a common iron core which greatly increases their mutual inductance. The iron core is not a solid piece of iron, but is composed of thin sheets of metal. In some transformers there may be no iron

core. These are called air core transformers. Air core transformers are often used when dealing with very high frequencies. The mutual inductance of the windings of an air core transformer is necessarily comparatively small. At low frequencies, only small amounts of power can be conveyed from one circuit to another by air core transformers.

## RADIO AMPLIFYING TRANSFORMERS

The amplifying transformer used in radio receiving sets, whether of the audio frequency or radio frequency type is a coupling or a link between one stage and another in the building up of signal strength or volume strength. The action of the

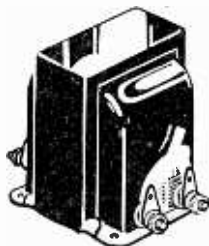

Audio frequency transformer.

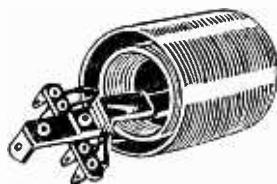

Radio frequency transformer.

Fig. 14A

amplifying transformer, as it is sometimes called, is based on changes in its magnetic field brought about by fluctuations in current flowing through the primary winding. These magnetic fluctuations, in turn, cause current with similar fluctuations to be induced in the secondary winding.

The purpose of using an iron core is to serve as an ideal path for the magnetic flux or field between the two windings. The iron core is constantly being magnetized and demagnetized and its magnetic polarity is reversed many times per second in audio frequency work. Audio frequency variations range between 30 and 10,000 cycles in the usual broadcast reception. But when it comes to handling of radio frequency currents, calling for frequencies or changes from 300,000 to millions of cycles per second, it is practically impossible to have an iron core, therefore, the iron core is dispensed with and an air core is substituted in radio frequency work.

## SELF-INDUCTANCE

The property which is called "self-inductance" causes the generation of a second electromotive force or voltage in any circuit whose current is changing its rate of flow. The flow of current in the circuit may be starting and then increasing, or it may be decreasing and coming to a stop, or it may be changing its direction of flow. Of course, there is a voltage being applied to the circuit in order to cause the flow of current, but the current itself causes a second and different voltage to appear. The ability of the circuit to generate this second induced voltage in itself is called the circuit's self-inductance or simply its inductance, in most cases. The self-induced voltage is called counter-electromotive force.

The induced voltage tries to prevent the current from doing whatever it may be doing at the time. If the current is on the increase, the induced voltage tries to hold it back, tries to prevent its increase; if the current is already decreasing, then the induced voltage tries to keep it going, tries to keep it from decreasing. Such application of self-induction is made use of to act in place of resistance coils in alternating current circuits. Again, in Radio, this principle is made use of to choke a high frequency current from places where it is not wanted. You, no doubt, have noticed such a radio frequency choke coil in many diagrams. Just remember that it works because of the first observation in studying self-induction.

As the effect of self-inductance is that of holding back the current flowing through the circuit, it can be measured just as resistance, and its magnitude expressed in ohms; when so expressed, it is called reactance.

## REACTANCE

When only direct current flows through a circuit, it is opposed only by the resistance of the conductors, but when alternating current flows it is opposed by both the resistance and the reactance. We can say that **inductive reactance** is the effect that a coil of wire has on an alternating current. Every coil of wire has inductance, that is, any change of current in a coil causes a voltage which opposes the change of current. The effect of a coil of wire on alternating current is to hold back the current, or to temporarily choke it. This reactance effect which appears in a coil is called "inductive reactance" because it is

caused by inductance. The inductive reactance turns part of the energy of the alternating current into a magnetic field around the coil, or causes such a field to be built up. As this magnetic field collapses it returns energy to the circuit and that is why we say that reactance differs from resistance in that it does not lose energy, but stores the energy.

Later on in this text book, we will take up the difference between "inductive reactance" and "capacitive reactance."

### OHM'S LAW FOR A. C.

Now, having learned what we mean by reactance in a circuit, we will represent reactance by the letter X, then just like we did with Ohm's Law in the last lesson for direct current, we simply divide the voltage V by the reactance X in order to obtain the value of the current I, or

$$I = \frac{V}{X} \text{ or amperes (effective)} = \frac{\text{volts}}{\text{ohms}} \text{ (effective)} \quad (1)$$

You see, reactance is spoken of as so many ohms, just as the resistance is, therefore, the relation can be expressed in three ways, so that if we know any two of the three things, reactance, voltage, or current, we can always find the third, viz:

$$I = \frac{V}{X} \quad \text{or} \quad V = I \times X \quad \text{or} \quad X = \frac{V}{I} \quad (2)$$

Now it remains for us to find out how to determine what the reactance X is in a circuit. When we have only a coil in the circuit, or rather, no condenser in the circuit, we call the reactance "inductive reactance," since it is due to the inductance. On the other hand, if we have only a condenser in the circuit, we would have "capacitive reactance," since it would be due to the capacity in the circuit. Then again, we have a combination of these, which will be explained later.

### CONDENSERS

A condenser is formed by any two surfaces of metals separated by some insulation; each metallic surface or plate may be in one piece or composed of several plates connected together. The capacity, that is, the amount of electricity which will be stored in the condenser at a given voltage increases as the area of the plates used is made larger, as the number of plates is increased, or as the dielectric between the plates is made thinner.

A simple explanation of the action of a condenser may be explained by water analogy. If a rotary pump is connected to a

tank of water and in the center of this tank is stretched a piece of rubber as shown in Figure 15, when the pump rotates, the water from A will be pumped up and compressed in B, in which case the rubber will be forced out of shape until the back pressure is sufficient to prevent any more water from filling B. This is equivalent to a condenser connected to a battery supplying direct current to the circuit. In which case the condenser gets charged until full, when no more current can flow. In the tank, the amount of water which B can hold depends upon its size. In the condenser, the quantity of electricity stored up (at a given voltage) depends upon its capacitance (surface area and number of plates). In the water tank, the thinner the rubber sheet, the more water B will hold because the thinner it is, the further it will stretch, as shown in Figure 15. In the condenser, the thinner the dielectric or insulation between the plates, the more electricity the condenser can store at a given voltage. It can be clearly seen from the foregoing explanation that direct current will charge a condenser but cannot flow through the circuit once it is full.

Now, taking the same analogy to show the effect of an alternating current in the same kind of circuit, suppose the rotary pump is replaced by one having a reciprocating motion representing an alternating current generator. See Figure 16. One may easily see that the water may flow back and forth through the pipe when the piston is operating, the pressure in A and B moving the rubber sheet up and down in accordance to the motion of the water. In an electrical circuit, as shown in Figure 16, the alternating current can flow in a similar manner because the condenser is charged and discharged at each reversal of the alternating current.

$$C = \frac{\text{capacity of one condenser}}{\text{number of condensers}} = \frac{.001}{2} = .0005 \text{ mfd.} \quad (3)$$

10 \* To increase the capacity in a circuit, several condensers may be connected together in parallel. In this case, the total capacity is equal to that of all the condensers added together. For example, if three condensers of .001, .002 and .0005 mfd. capacity were connected in parallel, the total capacity is .0035 mfd. When condensers are connected in series, the total capacity is lower than that of the smallest one in the group. For example, if two .001 mfd. condensers are connected in series, the total capacity is .0005 mfd.—that is, half the capacity of one of the condensers.



The formula (3) on page 22 can only be used when all condensers have the same capacitance.

Condensers when connected in a circuit through which alternating current flows, oppose the flow of current to a certain extent, depending upon the frequency. For a given capacity, the lower the frequency, the less current will pass through the condenser until zero frequency is reached, when no current at all can flow through it. It is as though the resistance in the

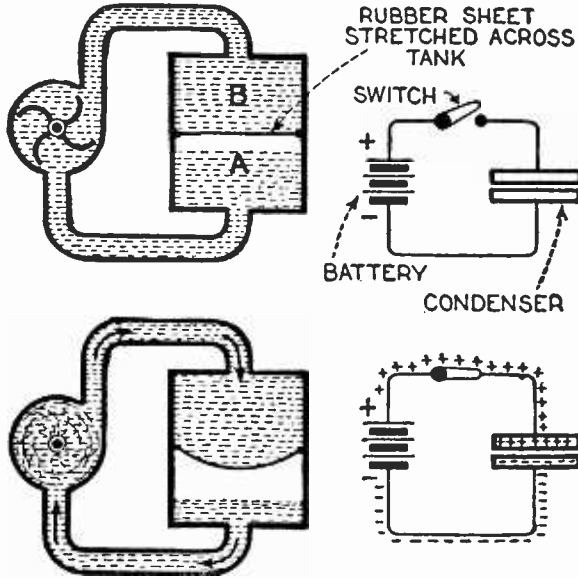

Fig. 15—Hydraulic analogy showing how a condenser is charged with direct current.

circuit were automatically increased as the frequency decreases. This effect is called "reactance" and explains why it is necessary to use large capacities when low frequencies must pass through a condenser, as for instance, in a resistance coupled audio amplifier where the low frequencies (low notes) cannot be satisfactorily amplified by the tubes if the coupling condensers are too small.

### CAPACITIVE REACTANCE

Reactance, as stated before, is the name given to the opposition of flow of alternating current when this opposition is caused by the inductance of a coil, or by the capacity of a condenser. Reactance is measured in ohms. The total opposition to the passage of an alternating current through a circuit is grouped

under the head of **impedance**. Reactance is called the reactive component of the circuit impedance. Reactance caused by a condenser capacity is called capacitive reactance. Either kind of reactance may act to hinder the flow of alternating current. **Inductive reactance**, the reactance of a coil, increases with the increase of frequency and is often called **positive reactance**. **Capacitive reactance**, the reactance of a condenser, grows less with increase of frequency, and is often called **negative reactance**. The values of inductive reactance may be preceded by the positive sign plus, while the value of capacitive reactance may be preceded by the negative sign minus. When the frequency is measured in kilocycles and the inductance in millihenries, the inductive reactance in ohms is as follows:

Inductive reactance = 6.2832 x frequency x inductance.

The same formula holds true when the frequency is measured in cycles, and the inductance in henries. If the frequency is measured in kilocycles and the inductance in microhenries, the formula becomes:

Inductive reactance = .0062832.x frequency x inductance.

The number 6.2832 is the approximate value of  $2\pi$  the Greek letter which stands for the ratio of a circle circumference to its diameter. When the frequency is measured in cycles and the capacity in microfarads, the capacitive reactance in ohms is as follows:

Capacitive reactance = 159,154.6 ÷ frequency x capacity.

If the frequency is measured in cycles and the capacity in micro-microfarads, the formula becomes:

Capacitive reactance = 159,154,600 ÷ frequency x capacity.  
159,154.6 and 159,154,600 are constants which are necessary to use in these formulas.

If the inductive reactance which is considered as a positive quality just equals the capacitive reactance which is considered a negative quality, the two will balance each other so that there is no effective reactance remaining in the circuit. The only opposition then remaining to the flow of alternating current at the particular frequency being considered is the resistance, and the circuit is resonant at that frequency.

To a direct current, a condenser has extremely high resistance. In fact, to direct current whose voltage is not great enough to break through the dielectric, the condenser forms an open circuit or an infinitely high resistance. A condenser does not offer this infinitely high resistance to alternating current,

but offers only reactance. Here again, the reactance does not cause a loss of energy but stores it on the plates of the condenser in the form of electric charges which will return the energy to the circuit.

To an alternating current of given voltage and amperage, a large condenser has less reactance than a small one and the larger the capacity of the condenser, the less is its reactance to a given current and voltage.

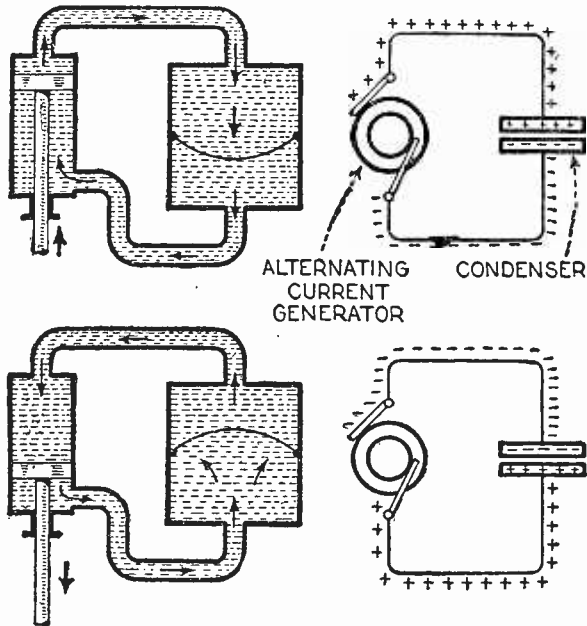

Fig. 16—Hydraulic analogy illustrating the flow of alternating current through a condenser.  
(Courtesy of Radio Electric Laboratories.)

### IMPEDANCE

Impedance is the effective resistance or opposition to flow of current in an alternating current circuit when this circuit contains in addition to ohmic resistance, inductance, capacity, or both. Impedance is measured in ohms. The impedance of a circuit is the combination of the circuit reactance and its resistance, but the impedance is not equal to the sum of the reactance and the resistance, but is equal to the square root of the sums of the squares of the resistance and the effective reactance. This is shown by the following formula (4):

If a circuit contains only resistance and inductance, the impedance is found by using a number of ohms resistance and a

number of ohms inductive reactance, using the formula given below. If a circuit contains only resistance and capacity, the impedance is found from the ohms of resistance and the ohms of capacity reactance, but when a circuit contains both inductance and capacity in addition to resistance, it is necessary to first compute the effective reactance of the inductance and capacity together. This net value of the total reactance is then used in the following formula. (4)

$$\text{Impedance} = \sqrt{(\text{ohmic resistance})^2 + (\text{effective reactance})^2}$$

With both inductance and capacity in a circuit, the tendency is for them to balance each other and the net reactance is the difference between the two reactances. If the inductive reactance be greater, as is usually the case, the capacitive reactance is subtracted from it. If the capacitive reactance is greater than the inductive reactance, then the inductive is subtracted from the capacitive reactance to obtain the net or effective reactance. The current in amperes which flows in an alternating current circuit is equal to the number of volts divided by the number of ohms impedance, thus:

$$\text{Amperes} = \text{volts} \div \text{impedance.} \quad (5)$$

**NOTE.**—It is not necessary for students to spend much time on the formulas given in this text book, but you may find them useful when studying advanced text books.

## RESONANCE

The flow of alternating current in a circuit is opposed by three things: The resistance, the inductive reactance and the capacitive reactance. The resistance is due to resistance of the various conductors in the circuit and to the connections between them. It may be reduced by using conductors of the proper size and of good conductivity, but resistance cannot be completely eliminated from any circuit. The inductive reactance depends on the inductance in the circuit—the greater the inductance in the coils and other parts, the greater the resultant inductive reactance. The capacitive reactance depends on the capacity of the condensers and other parts in the circuit. The greater the capacity, the less the capacitive reactance.

When we speak of adjusting the capacity and inductance to resonance, we refer to resonance at a certain frequency. When the inductive and capacitive reactances are equal and their

effects are neutralized the circuit is said to be in a state of resonance. In a simple circuit containing inductance and capacitance in series, at any given frequency, there are certain values of capacity and inductance which cause resonance at this frequency, but at no other frequency. If the frequency in the alternating current circuit should change, it would be necessary to make a different adjustment of either inductance or capacity in order that the resonant condition might again be obtained at the new frequency. This is why we must readjust dials for other stations. When a given adjustment of capacity and inductance or a given relation between their reactance will balance out for one certain frequency and a current at this frequency will then flow through the circuit in maximum volume, although currents at other frequencies still will be opposed by the reactances, the circuit is then said to be in resonance at that frequency.

If the frequency is lowered, either the inductance, the capacity, or both, must be increased to maintain resonance. If the frequency is increased, then the capacity, the inductance, or both, must be decreased to maintain resonance. In other words, the greater the frequency, the less must be the capacity and inductance, and the lower the frequency, the greater must be the capacity and inductance.

This is the principle of tuning a Radio receiving set to incoming signals, when we adjust the capacity of the variable condenser or vary the number of turns of wire on the tuning coil or both so that the reactance is as little as possible, or as we do generally, actually make it zero.

In other words, when we tune a circuit like the ones we have in Radio receivers, we adjust the reactances so that their sum is zero. Generally, we do not adjust the inductance (of the coil) but only adjust the capacity. That is why we always use a variable condenser for tuning. Suppose we are trying to receive a signal which has a certain frequency; then, when the current due to the signal flows through the tuned circuit, the coil has a certain reactance to it, and the condenser likewise has a certain reactance to it. In general, this reactance will be enormous, perhaps millions of ohms; but, as we turn the variable condenser dial, we change the capacity of the condenser so that we are at the same time changing its reactance to the incoming signal. Soon we find a position on the variable condenser dial at which we begin to hear the signals; this means that we have so adjusted the reactance of the condenser that when summed up

with the reactance of the coil, the net reactance is no longer very great. In reducing the net reactance, we have permitted a much greater current to flow in the tuned circuit and on account of this greater current we are now able to hear the signals. Before, when the reactance was very high, there was most likely a very small current flowing in the tuned circuit, but this current was so small that we could not hear the signals properly.

Now, finally, as we continue to turn the variable condenser dial, we get to a position where the loudness of the signals is greatest. This is the condition of resonance, as we call it; the circuits are now tuned to the same frequency as the frequency of the incoming signals. If we turn the condenser dial still further, the signals will get weaker, indicating that the circuits are no longer in resonance.

It is clear, then, that there is one certain adjustment of the circuits when receiving signals of a certain frequency, which will result in the loudest signals. This is the condition of resonance as we have said, and is obtained when we make the net reactance of the circuit zero. We do this by making the **inductive reactance**, due to the coil, **exactly equal** to the **capacitive reactance**, due to the condenser, and since we have opposite algebraic signs (that is, one is plus and the other is minus), they sum up to zero. So now, in order to have resonance, we must have this:

Inductive reactance minus capacitive reactance equals zero. This is the same thing as saying that—

Inductive reactance equals the capacitive reactance. This is the most important thing that we have to learn in connection with tuning and tuned circuits. This relation gives you the principle of resonance, and if you only get to understand it clearly, you will have little or no trouble in your study of Radio. You must first get into your mind the idea of what reactance is; after that, the idea of resonance comes easily enough.

Therefore, before you go on with the following lessons of this course, be sure you understand all that is in this lesson thoroughly. If you fail to understand it fully after the first reading, read over the lesson again.

We have now come to the end of this lesson. The material contained in it is of utmost importance to you in your study of Radio, so be careful that you learn it well and study it hard, for your ability to understand all of the other lessons chiefly depends on your ability to understand this one thoroughly. You have

learned how to speak of the inductance of a coil and the capacity of a condenser. You have learned how to find out how much of these things are required in tuning circuits in order to tune these circuits to various wavelengths or frequencies. But you do not yet know how to build a coil so that it will furnish the amount of inductance you require, or the condenser that will have the required capacity. These things are reserved for a future lesson, so you have all you can do at this time to digest all that is in this lesson. Be sure you get out of it all that there is in it.

---

### TEST QUESTIONS

Number your Answers 8—2 and add your Student Number.

1. Explain the difference in action between direct and alternating current.
2. What is the frequency of A. C. in cycles per second used for industrial purposes?
3. Upon what does the intensity of the field and the density of the magnetic lines of a solenoid depend?
4. What effect does an iron core have on a solenoid?
5. Who discovered the principle of electromagnetic induction?
6. State three ways in which a current can be induced in a coil of wire.
7. What kind of current is produced by induction?
8. Upon what will the voltage and current of the small generator, Fig. 10, depend?
9. Does the amperage as well as the voltage increase in the secondary of a step-up transformer?
10. What is the result of connecting condensers in Parallel?  
In Series?

