

NATIONAL RADIO INSTITUTE

Complete Course in
PRACTICAL RADIO

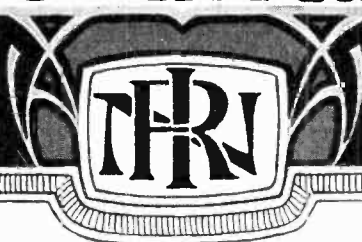

Radio-Trician

(Trade Mark Reg. U. S. Patent Office)

Lesson Text No. 7

(2nd Edition)

FUNDAMENTAL

D. C.

THEORY

Batteries & etc

Originators of Radio Home Study Courses

... Established 1914 ...

Washington, D. C.

"Let every man be occupied, and occupied in the highest employment of which his nature is capable, and die with the consciousness that he has done his best."—Sidney Smith.

HAVE A NEAT DESK

A Personal Message from J. E. Smith

A neat desk and a neat set of lessons indicate a neat and orderly mind. A neat personal appearance is a well-known business asset. Neatness counts in study. If your work is neat and orderly, the instructor is prejudiced in your favor. The work may be of poor quality but if it is neat, you will receive a higher grade. On the other hand, work of high quality but put up in a "sloppy" manner will not receive the mark it would otherwise deserve. This factor of neatness in mental work is a business asset as well. Nobody wants a set of blotched lessons.

What are the factors in neat work? In writing up your lessons, there are several that contribute to neatness: (1) Use only clean pens. Pens that are dirty or rusty are sure to leave a blotched page. (2) Use only smooth ink of good quality. Poor ink is sometimes responsible for a bad looking page. (3) Keep plenty of blotters on hand and use them freely. Do not try to make one blotter last you a life time. When it gets full of ink, throw it away and get a new one. (4) Do not erase unless you have to. (5) Do not "ride your pen." The pressure exerted on a pen makes a great deal of difference in the looks of the page. The neatest page is obtained by a moderate and constant pressure. (6) Dirty fingers are often the cause of dirty papers and "messy" work.

Copyright 1929, 1930
by
NATIONAL RADIO INSTITUTE
Washington, D. C.

Radio-Trician's

(Trade Mark Reg. U. S. Patent Office)

Complete Course in Practical Radio

NATIONAL RADIO INSTITUTE

WASHINGTON, D. C.

FUNDAMENTAL D. C. THEORY

We have now finished our "bird's-eye-view" of radio. The first six lessons of this course were written as a "bird's-eye-view" so that you would be able to grasp the whole meaning of radio in a very short time. These first six lessons gave you a clear idea of what it is all about; of course, you may not be able to design radio receivers as yet, but at least you are in a position to understand what you hear and read about in radio. **Radio** is no longer a mystery to you. You have learned that it is a genuine product of hard work, in research and design, and more of the development of radio can be ascribed to this than to so-called "inventions."

The foundations of radio were laid down, not by "radio engineers" but by teachers and students of electricity and **physics**. As we look back into the history of science during the past hundred years or so, and at the same time keep our eyes on radio as it is today, we will find that radio was made possible by such men as Maxwell, Hertz, Michael Faraday, Prof. Henry, Prof. Ohm, and a host of others. But strange to say, most of these men knew nothing of radio or at least of radio used as a means of communication. Faraday and Maxwell, for instance, developed, mathematically, the theory of radio waves, but, of course, they did not call them "waves." They gave them other names. Furthermore, they did not produce these waves in the laboratory.

Maxwell, as another instance, showed that it ought to be possible to create a certain kind of wave motion from the discharge of a condenser, and he showed mathematically that these waves ought to be very similar to, if not the same as, light waves. And to go farther, he gave to us many of the laws of these waves.

But Maxwell, as we have said before, did not demonstrate the existence of these waves practically. He may have been sure that when he discharged a condenser that there were such waves being generated, but he had no means of showing that they

were there. It remained for Prof. Heinrich Hertz of Germany to give the practical demonstration. Hertz transmitted and received electric energy over distances of a few feet or a few yards; he generated the waves from a discharge of a condenser, and showed that they were present when he held a small broken ring of copper where the waves could pass through it. When the waves were being generated, a small spark took place at the break in the ring.

We shall not go into Hertz's researches, for they are mainly of historical interest. Nevertheless, it is surprising how much of radio, as we know it today, is the result of work done a long time ago, and it is equally surprising how much of radio which seems new to us is really fairly old.

But the point we wish to bring out here is that radio, as we know it, owes its existence to men who worked on problems which may seem to have no connection with radio. But think a minute, and remember that radio works by **electricity** and that in order to know radio we **must also know the laws of electricity**. It is the laws of electricity which we shall begin to study in this lesson. In this lesson, and in the next, we will not deal with radio proper; we will deal with "Electricity," and we will learn the laws of electric charges, and of electric currents. Then, after we have gone through this period of our study, we will be in a position to study radio waves themselves, and will learn in great detail all the things which we could not put into our "bird's-eye-view."

Many of the laws governing electricity are as simple as A, B, C. You can learn them without much difficulty, and, once learned, they will stay with you because the subject is so intensely absorbing.

STATIC AND DYNAMIC ELECTRICITY

There are two kinds of electricity, static and dynamic. The electricity that flows through the electric light wires in your home is called **dynamic or current electricity**. Current electricity is the electricity of the workaday world. It is generated in batteries and dynamos. When you see Vacuum Tubes in a radio receiver, an electric light, an electric motor, a door-bell, or other electrical devices that we use today, always remember they are operated by current electricity.

Now, there is another kind of electricity that is known as **static electricity**. If you will refer to the dictionary, you will

find that static means "to remain at rest." It is only in very rare cases that static electricity is used in the workaday world. Static electricity is that which sparkles in your hair on a cold winter morning when you comb it with a rubber comb. When you come too close to a rapidly moving leather belt, a spark is apt to jump off and give you an unpleasant shock. This is static

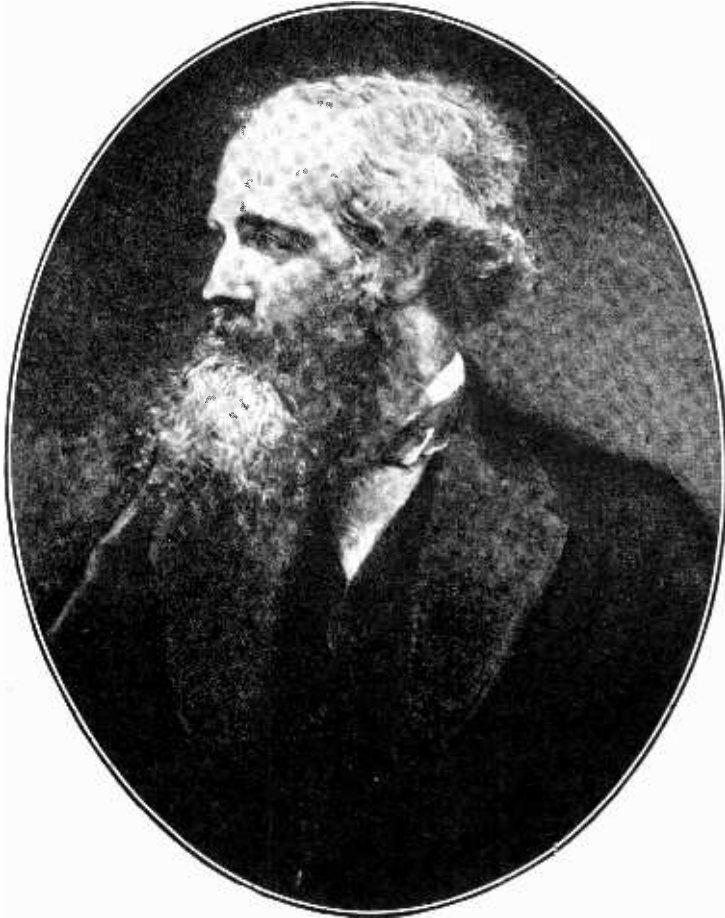

James Clerk Maxwell, in 1863, formulated the theory that the discharge of a condenser across a spark gap sets up disturbances in space which traveled at the same speed as light.

electricity. We might say that static electricity is "tramp" electricity, because it refuses to work.

Tremendous charges of static electricity accumulate in the clouds as they burst to earth with a terrific roar. That is lightning, which is made up of billions of little charges of electricity.

Let us keep these facts in mind:

- + 1. Current or dynamic electricity is electricity in motion.
- 1 2. Static electricity is electricity at rest.

STATIC ELECTRICITY

Electrostatic charges, or electric charges, as they are frequently called, may be produced by rubbing a glass rod with silk, or by rubbing a rod of sealing wax with flannel. The rubbing operation causes the rod in either case to be electrified.

The development of radio waves greatly increased the need for a more intense study of static charges. Small charges which accumulate on a short length of small wire such as the filament of a vacuum tube, the connecting wires between different parts of apparatus and also the charges which may accumulate or be induced on metal surfaces, such as the grid and plate of a vacuum tube, become of vast importance in the design and operation of both transmitting and receiving sets in connection with short wavelengths which are fast becoming standard practice.

There are two kinds of electric charges, to which the names **positive** and **negative** have been applied. The charge developed on glass when it is rubbed with silk is arbitrarily called positive, and that developed on wax, being just the opposite, is called negative. Although only one kind of charge was present on either charged rod, neither charge could be developed without the development of the other. In this case, the opposite charges reside on the cloth with which the rod was rubbed. The piece of silk has a negative charge and the piece of flannel a positive charge. Likewise, if equal and opposite charges are combined, the effect of each is neutralized.

ELECTROSTATIC LAWS

The following laws apply to electrostatic charges:

1. When two dissimilar unelectrified substances are rubbed + together, one assumes a positive and the other a negative 2 charge.
2. An unelectrified body on coming in contact with an electrified body becomes electrified with a charge similar to that on the electrified body.
3. Similarly charged bodies repel each other. Dissimilarly charged bodies attract each other.

Figures 1 and 2 illustrate the action of unlike and like charges.

DYNAMIC ELECTRICITY

Electric Current. There is no subject in the world of greater interest than current electricity. We are going to learn something about this great force now.



Heinrich Hertz, who is recognized by all as the real founder of present-day Radio communication. These Radio waves are sometimes called Hertzian waves.

An electric current is a flow of electricity, and manifests its presence by the magnetic or heating effect it produces. Just as water can be forced through a pipe and made to do work, so can electricity be forced along a wire and made to do work. The exact nature of an electric current is rather speculative, but

according to the electron theory, it is considered that electrons in motion constitute an electric current.

To make matters easy we are going to compare the flow of electric current through a wire with the flow of water through a pipe. That is about the easiest way to get at it. Let us assume that we have water flowing through an iron pipe with an internal diameter of one-half inch. Do not get confused. We are not trying to tell you that electricity is like water; we are merely trying to tell you how easy it is to understand the flow of electricity by comparing it with water.

A long pipe, as shown in Figure 3, is filled with water. The pipe represents a conductor, and the water illustrates the electricity in the conductor. Both ends of the pipe are held upwards on a level with one another, so that normally there is no difference in pressure acting at each end of the tube, and therefore the water will not flow through the tube.

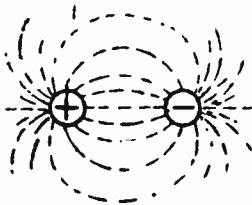

Fig. 1—Attraction of unlike charges.

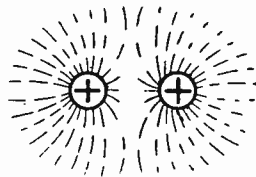

Fig. 2—Repulsion of like charges

If, however, we exert a pressure at one end of the pipe by blowing down it, or by increasing the height of one end above the other, or, better still, by connecting a tank of water to it which is situated at a higher level than that on which the experiment is being carried out, as shown in Figure 4, then the water will immediately flow through the pipe.

By connecting the tank to one end only of the pipe, we exert a difference of pressure on the two ends of the pipe, but if we connect the tank simultaneously to both ends of the pipe, then there is no difference of pressure on the two ends of the pipe, and, consequently, no water will flow through it.

As the water represents electricity, the flow of water represents an electric current.

What will the number of gallons of water per minute passing through this half-inch iron pipe depend upon? You know the answer to this. If you do not, put on your thinking cap. One thing it will depend upon is the pressure, is it not? The higher

the pressure of the water, the more gallons we will receive per minute through the pipe. Now, there is another thing that the delivery of the water depends on. What is that? The size of the pipe. The smaller the pipe, the greater the resistance offered to the flow of the water. If we had a larger pipe, the resistance would be less.

Now, for these words that we have heard so often, **VOLTS**, **AMPERES** and **RESISTANCE**. First, let us say that the pressure of the water in our half-inch pipe represents voltage. We will call the rate of flow gallons per minute, amperage or amperes. Then the resistance will depend upon the size of the pipe.

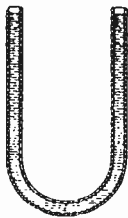

Fig. 3—Water pipe.

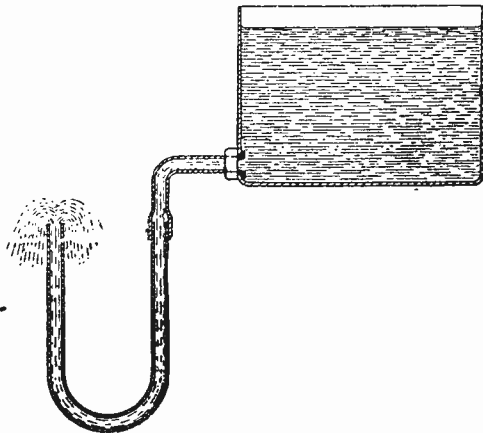

Fig. 4—Water pipe attached to a tank of water

Now, let us assume that we have a wire with a current of electricity flowing through it. The resistance that this wire offers to the flow of the current will depend upon its size (length and diameter) and the metal from which the wire is made. If we had a very small wire, the resistance would be great and very few amperes would flow through it. If we increased the voltage (pressure) we could cause more current to flow. If we doubled the size (area of cross section) of the wire carrying the current, the resistance would be cut in half, and the current flowing would be doubled.

We must look upon electrical voltage as pressure, the pushing force that causes the amperes to flow through a wire. Remember that the amperage of an electric current is really the current itself, the working force. Resistance is merely that portion of an

electrical conductor that tends to hold the current back. Keep in mind the fact that any moving substance, like a block sliding across the floor or a baseball rolling down a hill, meets with resistance. In fact, we meet with resistance in our daily lives. We must keep plugging along. Some of us do not have enough pressure, others have too much pressure and not enough amperage.

The next time you hear some one mention a high voltage current, say, for instance, 10,000 volts, do not jump at conclusions and think this is a powerful source of electricity. Voltage is no measure of electric power, it is only the pressure. We could have a very small pipe carrying water under a terrific pressure, but would that pipe deliver as many gallons of water per minute as a large pipe of water under the same pressure? No, it would not. In the same way, we can have a small electric current with an extremely high voltage. In the ignition system of automobiles, we have an electric current with a voltage of as high as 10,000 volts, but the amperage is small.

What if we had a very small copper wire running from Washington to Baltimore and we wanted to send a current of electricity over this wire? We would have to use a high voltage in the same way that we would have to use a high pressure if we had a very small pipe. As we increased the voltage, we would increase the flow of the current and we would receive more amperage at the opposite end.

Voltage alone cannot do the work. An electric current must have considerable amperage before it is able to turn motors, etc.

So far, this has been very easy, hasn't it? There is nothing difficult about this subject of electricity. Let us go on. It gets more interesting.

GENERATION OF CURRENT ELECTRICITY

Now that we have learned what current electricity is, we will be interested to know how it is produced. There is no use of us stopping half-way, we have to make a good job of this proposition. In general, current electricity is produced in two ways, by chemical means and by mechanical means.

Where any great amount of power is desired, the dynamo is used because it is the most convenient and efficient method of procuring current in large quantities. The word "dynamo," which is the name applied to a machine for generating electricity,

comes from the word dynamic and in recent years the Radio Engineer has developed a new type of loud-speaker operating on the principle of the dynamo and is called the dynamic type of Radio speaker.

The chemical method of producing electricity is employed where a small amount of current is all that is required, such as for door-bells, radio sets and laboratory work, etc., or where a large amount is required for only a short time. The Dry Cell and Storage Battery is a familiar example of the chemical production of current on a small scale.

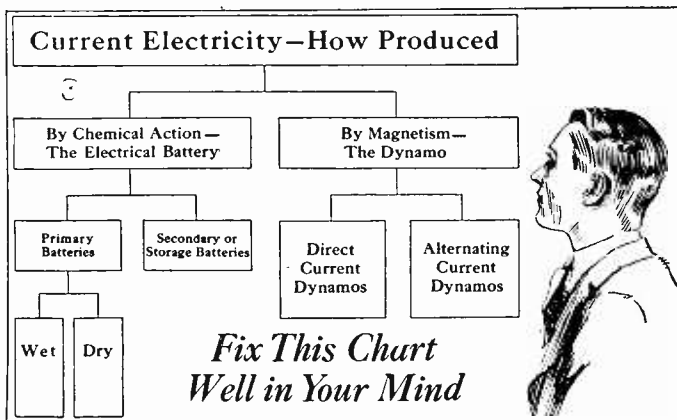

UNITS OF ELECTRICITY

In order to measure and define the different electrical factors of a circuit, certain practical standards or units have been adopted.

The following table has been arranged in a manner convenient for memorizing, clearly showing the particular quality or property which each represents and the relation which one bears to another.

- The unit of current is one ampere.
- The unit of quantity is one coulomb.
- The unit of electromotive force or pressure is one volt.
- The unit of resistance is one ohm.
- The unit of inductance is one henry.
- The unit of capacity is one farad.
- The unit of energy is one joule.
- The unit of power is one watt.

The **Ampere** is the electrical unit of flow of electric current. When a current of water flows through a pipe, the amount of flow can be defined by stating how many gallons per second are flowing; similarly in an electrical circuit, when a current of electricity flows through a conductor, the rate of flow can be defined by stating how many coulombs per second are flowing.

The standard method of checking the unit flow of current, the ampere, is measured very accurately by its chemical effect. Thus, a definite amount of a given metal will be deposited by a current when it is passed through a solution containing this metal. Equal quantities of electricity will deposit different amounts depending upon the different metals, but the amount of any given metal is always the same for the same quantity of electricity. Hence, the ampere (international unit) is that unvarying current which, when passed through a neutral solution of silver nitrate, will deposit silver at the rate of 0.001118 gram per second.

The **Coulomb** is the unit of quantity and can be compared with the unit of quantity for water, namely, a gallon. If a current of one ampere is allowed to flow past a given point for one second, then a charge of one coulomb has passed that point.

The **Volt** is the unit of electrical pressure often described as difference of potential, or electromotive force. It can be compared with the practical unit of mechanical force, namely, the pound. The flow of water, that is, the number of gallons per hour that will flow through a pipe of given length, size and shape, will depend upon the number of pounds of pressure applied at one end of the pipe, or, to put it more correctly, upon the difference in the number of pounds acting on the two ends of the pipe. Similarly, the flow of electricity, or the number of amperes that will flow through a conductor of given length, size and shape will depend upon the difference in the number of volts acting at each end of the conductor.

The **Ohm** is the unit of resistance. Resistance can be compared with mechanical property of friction, for example, with the friction between the water and the inside of a pipe when the water is flowing through the pipe, or the friction between a shaft and its bearings.

Just as friction occurs in a flow of water through a pipe or the rotation of a revolving shaft, so does resistance oppose the flow of electricity through a conductor. A conductor having a

resistance of one ohm will require an electromotive force of one volt to force a current of one ampere through it.

The **Henry** is the **unit of inductance**. Inductance is that quality of a circuit which tends to oppose any change in the flow of electricity. It should not be confused with resistance which offers friction to the flow of electricity. It can be described by comparison with the mechanical property of mass, as its effect in an electrical circuit is very much like the effect of the inertia and momentum of a heavy body in motion. It is well known that it takes a considerable time for an engine with a heavy fly-wheel to get up full speed. This is due to the inertia of the fly-wheel. Also an engine running at full speed takes a considerable time to be brought to a stand still. This is due to the momentum of the fly-wheel.

In the same way there is a tendency in a circuit to oppose any increase or decrease in the current flowing through it. This quality is called inductance. If an electrical pressure be applied to a circuit possessing inductance, current flowing as a result of the E.M.F. (voltage) will only gradually increase and the greater the inductance, the slower the rate of increase. Again, if, when the current is flowing through a circuit possessing inductance, the E.M.F. which is making it flow is suddenly removed, the current will gradually stop flowing unless, of course, the circuit is broken.

Thus, it will be seen that the effect of inductance in a circuit or on any current flowing through it is exactly similar to the effect of inertia in a body or any movement of that body.

4 One great difference between the effect of resistance and that of inductance in a circuit is that resistance absorbs energy and dissipates it in the form of heat, just as friction absorbs mechanical energy and dissipates it in the form of heat, whereas inductance only stores up energy when the current is increased, and gives its energy back when the current is decreased.

A circuit has one henry inductance when it requires one volt of pressure to make a change of one ampere in one second.

The **Micro-henry** is sometimes used as a **more convenient unit** when the circuits under consideration have very small inductances. **One micro-henry is one-millionth part of a henry.**

The **Farad** is the **unit of capacity**. Capacity is the property which a condenser has of holding a certain quantity of electricity; it can be compared to the property of mechanical flexibility of a spring. Similarly, the electrical unit of capacity is a

measure of the quantity of electricity which will flow into a condenser when a pressure of one volt is applied to it. Thus, a condenser which requires one coulomb of electricity to bring its plates to a potential difference of one volt, has a capacity of one farad. Such a condenser would require immense plates very close together; the unit is altogether too large to represent the capacity of ordinary condensers. In ordinary engineering practice, such as telephone circuits, "B" eliminators, etc., the microfarad is used as the unit of capacity.

A condenser of one microfarad requires a charge of one-millionth of a coulomb to charge it to one volt. Taking it in another way, a current of one ampere will have to flow only one-millionth of a second to charge the condenser to one volt potential difference, or one microampere flowing for one second would charge it to the same extent.

In some radio circuits, the microfarad is too large a unit to be conveniently used; a more suitable unit is the **millimicrofarad**, which is the thousandth part of a microfarad. Another unit is the **micro-microfarad** which is one-millionth of a microfarad.

An important point to grasp is that although energy is expended in charging up a condenser, this energy is in reality only stored up by the condenser, and is available for use by discharging that condenser through a useful channel, just as in the case of a spring, although energy is expended in expanding or compressing a spring, that energy is only stored up by the spring, and is available for use by discharging the spring in a useful way; for example, a spring used in a toy air gun for driving a shot when the spring is released.

The **Joule** is the practical unit of electrical energy or work. In order to cause a current of electricity to flow in a circuit, energy or work must be expended. The electrical unit of work is, as we have already stated, the joule and can be defined as follows. If a force of one volt is used to cause an electric current to flow through a circuit, one joule of work has been expended when one coulomb of electricity has flowed. From this definition of a joule in forms of quantity and pressure, it follows from the fact that one ampere of current is one coulomb per second, that a joule is also the amount of energy expended during one second of time in causing one ampere to flow through a resistance of one ohm.

The **Watt** is the electrical unit of power. Power is the work

done per unit time, or the rate of doing work. One watt is the power required to do one joule of work per second.

Now, since a flow of one coulomb per second is one ampere, it follows from the definition of a joule that one watt of power is expended when one volt is used to cause a current of one ampere to flow. This can be expressed as an equation.

Watts equals Volts multiplied by Amperes.

For convenience, the kilowatt is often used as a unit of electrical power instead of the watt; one kilowatt equals one thousand watts. For example, if a certain Broadcasting Station required 50 amperes at 110 volts to operate it, then the electrical power used is 110×50 which equals 5,500 watts or $5\frac{1}{2}$ K.W.

OHM'S LAW

We have now reached a point where we can consider the work of a very great German scientist whose name was Dr. Ohm. Dr. Ohm originated a very simple law. Do not let the word "law" scare you, since nothing could be easier to learn than Ohm's Law.

A very simple method for using Ohm's Law in three forms is to insert the three letters, E, I, R, in a circle, as shown below.

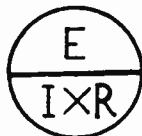

(1)

Fig. 5—Ohm's Law in a nut shell.

If the student wishes to find the value of any one of the quantities, he puts his finger over one letter in the circle and reads the value in terms of the other two.

The letter E is used to represent the electrical pressure since E is the first letter of the expression "E.M.F." (electromotive force).

I is used to represent the intensity of the current measured in amperes.

R is used to represent the resistance measured in ohms.

These letters are standard abbreviations adopted by both the American Institute of Electrical Engineers and the Institute of Radio Engineers, and are also considered standards in all text books.

A student should become familiar with the abbreviations and use them whenever referring to these terms.

VARIATIONS OF THE POWER EQUATION

Just as Ohm's Law has the three forms—I equals E divided by R, E equals I x R, R equals E divided by I, so this power equation P equals IE may have three forms, found as follows:

It is well to learn the equation in its three forms. P equals IE, P equals I^2R , P equals E^2 divided by R. This will save a considerable amount of mathematical work. When the volts and amperes are given, multiply the volts by amperes to get the watts (P equals IE), when the amperes and ohms are known, multiply ohms by the square of amperes (P equals I^2R), when volts and ohms are known, divide the square of volts by ohms (P equals E^2 divided by R). The result is the same as though we used Ohm's Law first to find the amperes and volts and then multiplied.

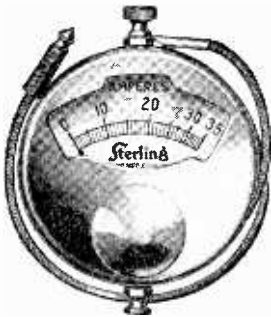

Fig. 6—D. C. Ammeter.

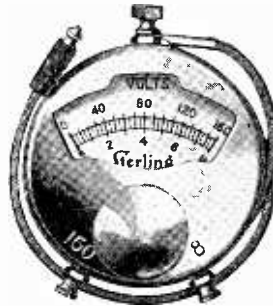

Fig. 7—D. C. Voltmeter.

MEASUREMENT OF CURRENT AND VOLTAGE

Meters. Any instrument which measures electrical values is called a meter. An ammeter measures the current in amperes, a voltmeter measures the electromotive force in volts, a wattmeter measures electrical power in watts. A milliammeter measures current in milliamperes or thousandths of an ampere. **Meters—Ampere and Volt.**

An ampere-meter or ammeter measures electrical current flowing in amperes, its scale being graduated in amperes and parts of amperes. A voltmeter measures electrical pressure, potential, or electromotive force in volts with a scale divided in divisions representing volts and parts of volts.

The principles upon which ammeters and voltmeters operate are the same. The ammeter allows a current to flow practically unhindered and indicates the effect of the current passing in a

circuit. The voltmeter offers such high resistance to the flow of current that this flow is practically stopped. The voltmeter then measures the effect of the voltage or pressure acting upon its terminals.

Ammeters are connected in series with the circuit in which the current is to be measured. That is, the circuit is opened and the ammeter inserted between the open end, as shown in Figure

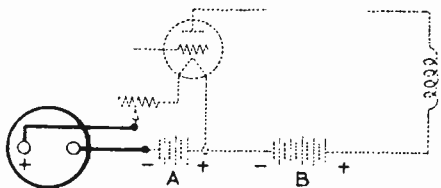

Fig. 8—Connections for measurement of filament or "A" Battery current using a D. C. ammeter.

8. Voltmeters are connected in parallel across the two sides of a circuit without opening the circuit when the voltage difference between the two sides is to be measured. Voltmeters are also connected across any two points in a circuit where the voltage drop between these points is to be measured. A voltmeter may be connected between any two points whose voltage difference is to be measured, either in an open circuit or a closed circuit. Such connections are shown in Figure 9.

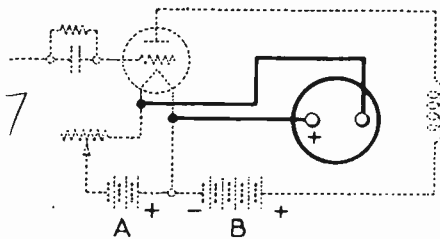

Fig. 9—Connections for measurement of filament voltage using D. C. voltmeter.

Ammeters may be used in a receiving circuit to measure the flow of current through the filament of vacuum tubes. Milliammeters are often used to measure the flow of the direct current in the plate circuit of the vacuum tube, this being an indication of considerable value in the proper operation of a Radio receiving set.

Voltmeters are often used to measure the voltage across the tube's filament terminals and other voltmeters or a double range

meter may be used to measure the voltage applied to the plate circuit.

The voltage or potential difference in a circuit is always measured between two points. For example, if we wish to cause a current of electricity to flow from one point to another, we

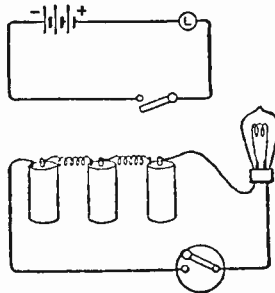

Fig. 10—Three dry cells, lamp, and switch connected in series.

have merely to raise the potential (pressure) of the first point above that of the second. Then a pressure (voltage) is set up proportional to their difference in potential; in other words, one point will have potential only with respect to the other.

Ranges of Meters. The range of a meter is the greatest value it will measure in amperes or volts. For example: A volt-

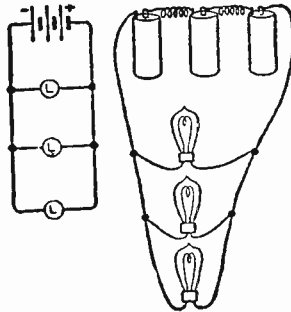

Fig. 11—Three dry cells connected in series and three lamps connected in parallel.

meter which reads from 0 to 8 volts is said to have a range of 8 volts. For measuring filament voltages, when using storage batteries, the voltmeter should have a range of at least 0 to 8 volts. For measuring plate voltages when using batteries, a voltmeter of 0 to 150 volts range is generally employed, since voltages greater than 150 volts are seldom secured from batteries. Voltmeters having two or more ranges combined in one instrument are often used with a switch or other connection so

that either range may be employed. These double range meters generally have the first range of from 0 to 8, 0 to 10, or 0 to 15 volts, and the other of 0 to 200 volts.

It is very important to learn the correct use of ammeters

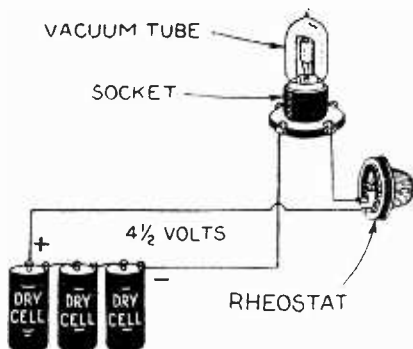

Fig. 12—Three dry cells connected in series give $4\frac{1}{2}$ volts, serving as the "A" battery for a vacuum tube such as the UX-199 or CX-299.

and voltmeters. An ammeter is inserted in series in a circuit, while the voltmeter is merely tapped across (in parallel) the circuit.

SERIES AND PARALLEL CIRCUITS

Electrical apparatus may be connected either in series or in parallel. In a series circuit all the current is made to pass

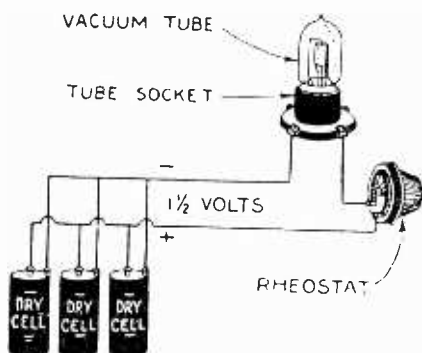

Fig. 13—Three dry cells connected in parallel give $1\frac{1}{2}$ volts, serving as an "A" battery for a vacuum tube such as the WD-11 or WX-12.

through every unit in succession, as Figure 10, where the battery, the lamp and the switch are so related.

In a parallel connection, the current is divided so as to pass through several units at the same time, such as the three lamps in Figure 11.

When battery cells (or for that matter any number of electrical sources) are connected in series, the total voltage supplied by them will be equal to the sum of the voltage of each unit, while the amperage will be equivalent to that of a single cell. When they are connected in parallel, the opposite holds true. The voltage is now that of one unit but the currents are added together.

So, for instance, if it were necessary to obtain a voltage of $4\frac{1}{2}$ volts from a set of three dry cells capable of delivering $1\frac{1}{2}$ volts each, it would be necessary to connect them in series, such as shown in Figures 11 and 12, in which case the amperage in the closed circuit would be regulated by the resistance in the circuit. If the same batteries are connected in parallel, however, current will flow at a pressure of $1\frac{1}{2}$ volts. See Figure 13.

Now let us try to apply in a practical way what we have digested in the previous paragraphs. We must come to understand that knowledge for knowledge's sake is absolutely useless. We must be able to use what we put into our heads—otherwise, the knowledge is useless. In this course, we have included only those things that are going to be of value to you in your Radio career.

Look at Figure 14 and you will see that secured to the upper end of the carbon is a binding post and that to the upper edge of the zinc cup is fastened another binding post. Binding posts are used to make it easy to connect the ends of wires to the carbon and to the zinc.

Five dry cells when connected together will give enough current to run a toy motor. These cells are connected with each other as shown in Figures 14 and 14-A. That is, the zinc of one cell is connected with the carbon of the next cell by a piece of copper wire about 3 or 4 inches long.

Any kind of copper wire will do for the connection, but the kind known as bell wire—that is, copper wire No. 18 Brown and Sharpe gauge covered with cotton thread and soaked in paraffin is mostly used. †

Let us solve this problem: Suppose that we desire to obtain 6 volts of electric pressure to be used in lighting the filament of a vacuum tube. This we desire to do by the use of dry cells. A single dry cell is able to produce a voltage of $1\frac{1}{2}$. Let us digress for a moment at this point. On one hand, we will assume that we have a cell the size of a thimble and, on the other hand, a dry cell the size of a barrel. Will the voltage increase in pro-

portion to the size of the cell? You will be probably surprised to learn that it will not. The voltage of the tiny cell and that of the big cell will be exactly the same, $1\frac{1}{2}$ volts. But what about the amperes or the current of the cells? Will that increase? The answer is "yes." The amperage of a dry cell increases with its size, due to the fact that its capacity is greater than a small cell.

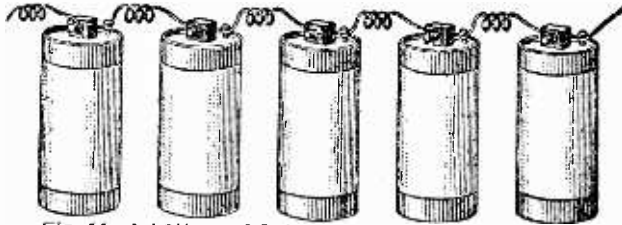

Fig. 14—A battery of 5 dry cells connected in series.

Well, let's go back to our original problem. If we wish to obtain 6 volts, we must use 4 dry cells, since 4 times $1\frac{1}{2}$ equals 6.

Do not make the mistake of calling a single dry cell a battery. A battery refers to a number of cells used in combination.

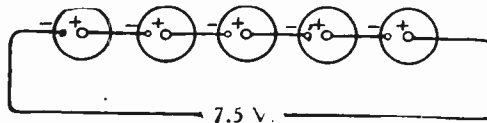

Fig. 14-A—Dry cells in series.

We will now consider the method of connecting up dry cells. The method of connecting them usually depends upon the duty they are to perform and upon the amount of current or voltage



Fig. 15—Dry cells in parallel.

we require for our use. Figures 14 and 14-A show how dry cells are connected in series. They are simply connected in a single line, but do not be too hasty here. Notice how the poles are connected together. We could not connect two positive poles together and expect the battery to function properly. If we look close, we will notice that the positive pole of one cell is connected to the negative pole of the next, and so on. We notice that the potential of the cells as they are connected in Figure

14-A is $7\frac{1}{2}$ volts. In other words, it is $5 \times 1\frac{1}{2}$, because we have five cells and each cell produces $1\frac{1}{2}$ volts. Dry cells of standard size produce a current of about 30 amperes. What will the current of this battery amount to? In this series connection, the current will be the amperage of one cell.

It should be understood that the initial current of a dry cell is measured by short circuiting a cell through an ammeter. The required drain in any kind of work is less than the lowest initial current.

A dry cell of a size used for A battery work in a radio receiver will deliver approximately $\frac{1}{2}$ ampere for 50 or 60 hours of intermittent use, or it will deliver approximately $\frac{1}{4}$ ampere for about 150 hours of intermittent use. As far as the voltage is concerned, only a single dry cell is required for the operation of vacuum tubes requiring 1.1 volt for their filament. These

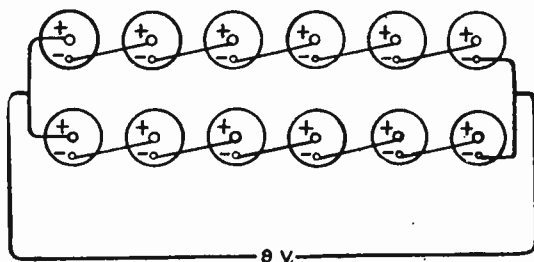

Fig. 16—Dry cells in series-parallel.

tubes draw $\frac{1}{4}$ ampere of current and this is the maximum current that may be taken from a single dry cell if any reasonable length of service is to be obtained. It is much better practice to connect two or three dry cells in parallel with each other to form the A battery supply in a receiving set using 1.1 volt tubes. There should be at least 1 dry cell in the parallel connection for each vacuum tube used in the radio receiver. In order to furnish current for vacuum tubes requiring 3 volts on their filament, such as the 199 tubes, three dry cells are connected in series, giving $4\frac{1}{2}$ volts pressure to the filament; therefore a variable resistance is used in the filament circuit to regulate the voltage and amperage so as to apply 3 volts to filament terminals of the tubes. The current consumption of these tubes is only .06 ampere, so four tubes may be operated in parallel and draw only 0.24 ampere which is within the current ability of a single dry cell. However, much longer life will be secured if six or more

cells are connected in series parallel, using 3 cells in each series bank.

Figure 16 shows what is known as a **series parallel** connection of dry cells. You will notice that this is a combination of the first two methods. The two sets of cells are called banks, and when cells are connected in this way, we must have an equal number of cells in each bank. The voltage of a series parallel connection is equal to the voltage of one cell multiplied by the number of cells in one bank, and the amperage is equal to the amperes of one cell multiplied by the number of banks. For example: $1\frac{1}{2}$ volts multiplied by 6 equals 9 volts and 30 multiplied by 2 equals 60 amperes.

Let us now turn our attention to a few practical applications

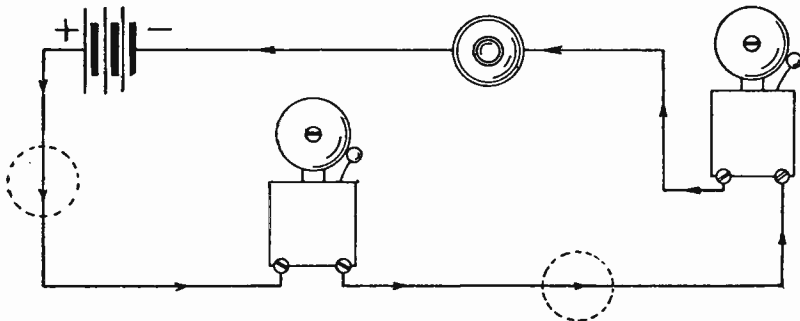

Fig. 17—Two bells, push button and battery connected in series. Push button may be placed in either of dotted-in positions instead of in location shown.

of these various types of circuits as apply to the wiring of push-buttons and bells in our homes.

The definition of a series connection is the same for other apparatus as for cells. Several lamps or bells may have to be connected to the same circuit. They may be arranged in series, applying the same principle. Figure 17 shows a circuit in which two bells are operated from one push-button. The bells are connected in series with each other and also with the button. The current must flow through the one before it can flow through the other. There is no other path for the current from positive pole to negative pole. It is immaterial on which side of the bells the push-button is located. An interruption of the circuit at any point means a stopping of the current. But the bells require the current in order to ring. It is likewise just as good to have the current flow through the bell in one direction as in the other. With the exception of special apparatus the direction of current through an instrument is of no importance. As long as the bell

is in working order and a current of sufficient strength is passing through it, it will ring. This arrangement of bells is very seldom used due to the fact that you have two interrupters in series and unless one is kept closed at all times the bells will not ring when the push-button is pressed, in other words it is an impractical arrangement.

Whenever the necessity arises for connecting any piece of electrical apparatus, no matter how simple the connection may be or appear, it is a good scheme to work out the connection on paper first.

Parallel Connection.

The proper way to connect vibrating bells is in parallel with each other. This means a connection where each device may be traced out separately from pole to pole of the battery. There is more than one path for the current to reach the negative pole

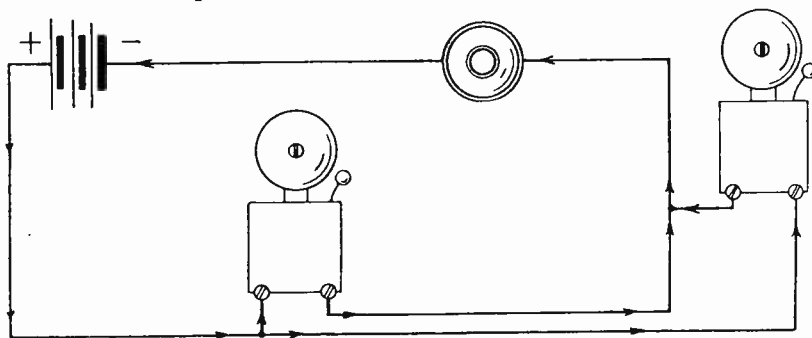

Fig. 18—Two bells connected in parallel, battery and push button in series.

after flowing from the positive. Divisions of current take place. The connection may be best understood by a specific example, Figure 18. Two bells are to be operated by one push-button. The button, in order to make or break the circuit for each bell as desired, must be in series with each. But, as can easily be traced from the drawing, it is possible to start out from positive, go through either bell and from there through the push-button in completing the circuit to the negative pole. Right at the point where a wire branches off toward the right-hand bell, the current divides. Later, after flowing through the bells, the currents again join and flow together back to the negative pole of the battery. Each one of the bells is connected to the battery and push-button independently of the other.

Should we desire to cut the wire of either bell somewhere between the branch-off and where it rejoins the system, we could

do so without any interference with the other bell circuit. Having two buttons in series means that the circuit is open normally at two points. Pressing one button does not close the other open circuit. But you could not very well press the vestibule button and the one on the top floor at the same time. That is exactly

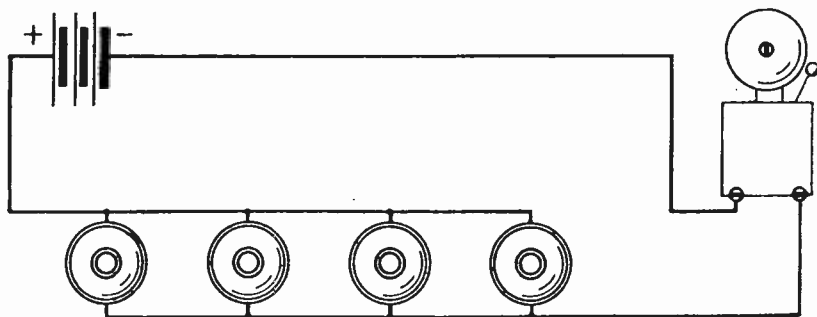

Fig. 19—A number of push buttons connected in parallel to operate one bell.

what would be required to close the circuit if the buttons were in series with each other. That leaves only a parallel connection to use—Figure 19 will show you how. Tracing from positive to negative, you will find each button to be in series with the bell—one after the other. But you can also trace out a separate, independent circuit for bell and each individual button without having any use for the others at that time.

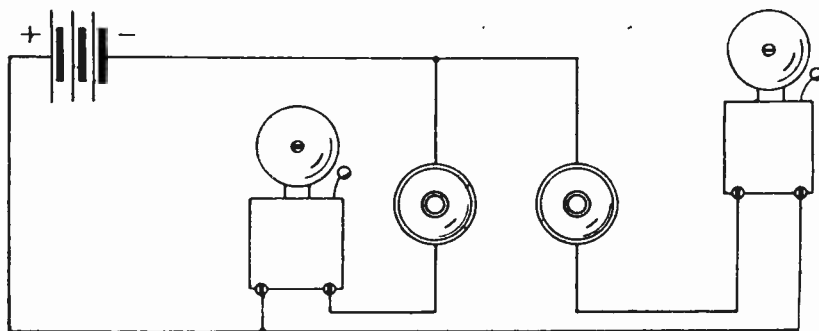

Fig. 20—Two independent bell circuits connected to the same battery.

In Figure 20, we see two bells and two push-buttons connected to the same battery in series, each button in series with its bell. Each button operates only one of the bells. They have nothing in common except the battery. The two independent bell hook-ups, each being fundamentally the same, are, therefore, connected in parallel with each other.

We may conclude that devices which we wish to work independent of others connected to the same circuit, should be in parallel with the others; while devices which should always and without fail operate simultaneously with others in the same circuit should all be in series with each other. There are modifications at times but not as a rule.

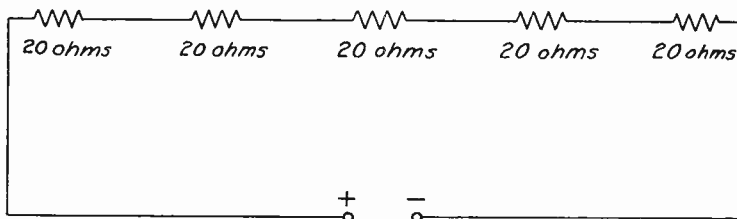

Fig. 21—Five resistances of 20 ohms each connected in series.

Resistances in Series and Parallel.

When we have resistances in series, we simply add them up to get the total resistance, or, if they are all the same values of resistance, we simply multiply the number of resistances by the resistance of one of them. For instance, if we have five resistances connected in series as shown in Figures 21 and 21-A, each of them having a resistance of 20 ohms, the total resistance is

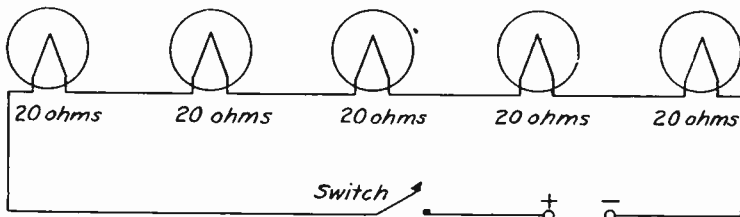

Fig. 21-A—Drawing showing five filament circuits connected in series.

20 multiplied by 5 or 100 ohms. But if we have different resistances, as, for instance, one of 5 ohms, one of 10 ohms and one of 4 ohms, all connected in series as shown in Figure 22, the total resistance of them all will be 5 plus 10 plus 4 or 19 ohms.

When we have several resistances, each having the same value, connected in parallel, such as a number of vacuum tubes about which we have already learned in the first six text books, we simply divide the resistance of one of them by the number of resistances. For instance, if we have five resistances connected in parallel as shown in Figures 23 and 23-A, each of them having a resistance of 20 ohms, the net resistance of this arrangement will be 20 divided by 5 or 4 ohms.

But if the resistances in parallel are not all the same, the situation becomes more complicated. It does not occur very often in practical Radio that we have more than two different resistances connected in parallel, so we will only consider one case, at least for the present. If we have one resistance R1 connected in parallel with another resistance R2 as shown in

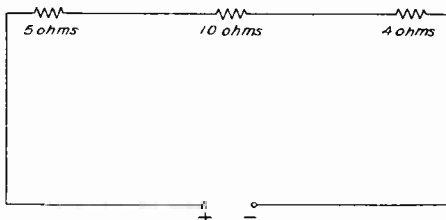

Fig. 22—Three unequal resistances connected in series.

Figure 24, then the total resistance of the two in parallel is expressed by the formula R equals R1 multiplied by R2 divided by R1 plus R2.

$$R = \frac{R_1 \times R_2}{R_1 + R_2} \text{ or } R = \frac{3 \times 6}{3 + 6} = \frac{18}{9} = 2 \text{ ohms.} \quad (2)$$

That is, the product of the two divided by their sum. To explain

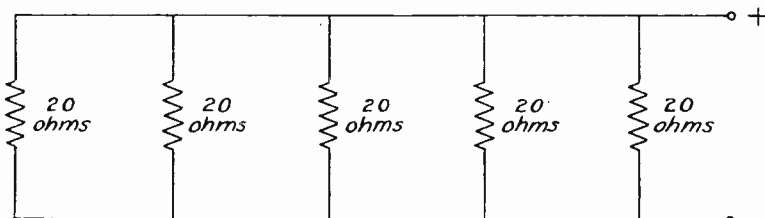

Fig. 23—Five resistances of 20 ohms each connected in parallel.

the use of this formula, suppose we have a resistance of 3 ohms connected in parallel with one of 6 ohms. The total resistance between the points A and B, Figure 24, is, therefore, R equals 3 multiplied by 6 divided by 3 plus 6 or 2 ohms.

In connection with resistances in parallel, it will be well to remember one thing particularly, and that is the joint resistance of the whole arrangement must always be less than the smallest resistance in the parallel arrangement. For example, in Figure 24, the joint resistance is less than 3 ohms. If we had a number of resistances in parallel, the joint resistance of all of them must be less than the smallest in the lot.

Resistance of Wires.

Now we must learn something about the resistance of wires, for you must know that wires are used everywhere in radio receivers, and as a matter of fact throughout all kinds of electrical work. And, in connection with wires, we must clearly understand that there are three things about them that are of great importance. One of these is the length of the wire, another is the diameter and the third is the material of which the wire is made.

10

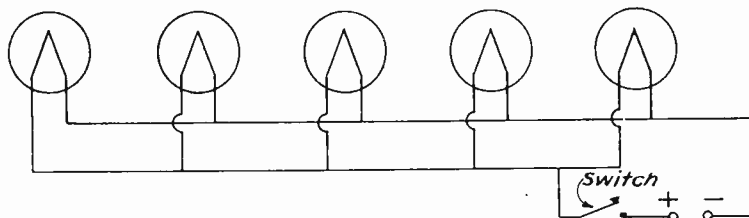

Fig. 23-A—Drawing showing five filaments connected in parallel.

If we double the length of the wire, we double the resistance, or if we triple the length, we triple the resistance. So it is clear that the resistance of the wire is directly proportional to its length. We also learned in the previous paragraphs that if we had several wires and connected them in parallel, the total or joint resistance would be lowered. So we may consider a large

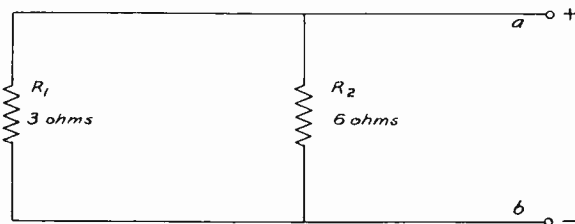

Fig. 24—Two unequal resistances connected in parallel.

wire as being equal to a number of smaller wires in parallel, and we learn then that larger wires have less resistance than smaller wires.

If we have two wires of the same length, but one made of copper and the other made of iron or some other material, the latter wire will have a resistance of so many times that of the copper wire. In other words, we can express the resistance of a wire made of a certain material as being so many times the resistance of another wire similar in all respects except the material of which it is made.

There has been given on these pages two tables which tell you the resistance, diameter, etc., of various sizes of wire. In order to illustrate how these tables are used, let us solve an imaginary problem. Suppose that this problem is as follows:

WIRE TABLE NO. 1
BROWN & SHARPE COPPER WIRE GAUGE
WIRE TABLE

Size B & S Gauge	Diam. Bare Wire in Inches	Ohms Per 1000 ft.
16	.0508	4.009
17	.0453	5.055
18	.0403	6.374
19	.0359	8.038
20	.0320	10.14
21	.0285	12.78
22	.0253	16.12
23	.0226	20.32
24	.0201	25.63
25	.0179	32.31
26	.0159	40.75
27	.0142	51.38
28	.0126	64.79
29	.0113	81.70
30	.0100	103.0

We have a certain Radio receiver, or we are going to build one, in which there are 4 vacuum tubes of the 201-A type. The filaments of these tubes are to be lighted by a 6-volt storage battery, and we must have a voltage of exactly 5 volts impressed on the filament terminals. The problem is then to design a rheostat or resistance which will do this.

TABLE NO. 2
TABLE OF RELATIVE RESISTANCE OF WIRES
OF VARIOUS MATERIAL

Material	Relative Resistance
Silver	.0925
Copper	1.000
Aluminum	1.587
Iron	9.
German-Silver	17.3
Manganin	29.3
Constantan	32.
Nichrome	100.

This problem has two parts; the first part you have already learned how to solve—that is, to fix what resistance is required. In order to familiarize you with this important step, we will go through it again.

Having 4 vacuum tubes connected in parallel, and each tube taking a current of $\frac{1}{4}$ ampere, the total current which the resistance must pass is 4 multiplied by $\frac{1}{4}$ or 1 ampere. Then, having a 6-volt storage battery, and requiring only 5 volts at the filament terminals of the tubes, we must have a 1-volt drop in the resistance. The resistance, therefore, must be:

$$R = \frac{V}{I} = \frac{1}{1} = 1 \text{ ohm.} \quad (3)$$

That is, the resistance of the rheostat must be one ohm.

Now, the next part of the problem is to find what kind of wire to use in the resistance, and how long this wire should be. Let us suppose we are going to use German silver wire in the rheostat, and that the size of wire is to be No. 20 B & S gauge. Now, the table of copper wire tells us that copper wire No. 20 gauge has a resistance of approximately 10 ohms per thousand feet. Since we desire a resistance of 1 ohm, then $\frac{1}{10}$ of 1000 feet equals 100 feet or the length required for 1 ohm of No. 20 B & S gauge copper wire in the rheostat. This is quite a lot of wire of that size to put in a small piece of apparatus like a rheostat, so now you see why we use such a wire as German silver.

Now, German silver wire has 17.3 times the resistance of copper, as you can see by looking at the table of relative resistances. So, when we use German silver in the rheostat, we only have to use:

$$\frac{100}{17.3} = 5.8 \text{ or approximately } 6 \text{ ft.} \quad (4)$$

of wire. So now the electrical design of your rheostat is completed, you must have in it 6 ft. of No. 20 German silver wire, and then your tubes will have a voltage of 5 volts on the filament terminals when your storage battery has a voltage of 6 volts.

Of course, it would have been possible to use other sizes of wire, or we may have used some other kind of material. The solution of the problem would have been the same in any case. But there are other things to consider besides obtaining the right amount of resistance. First, the rheostat must be fairly strong, so that it will not break easily. This means that we must not use very fine wire, and, for this reason, we have chosen No. 20.

So now we come to the end of our 7th lesson. In this lesson, we have learned quite a bit of the way and manner in which an electric current acts in the circuits of Radio receivers. In this lesson we have considered only direct current, or currents which always flow in the same direction. It is necessary to learn more about these currents before we are able to study the other kinds of currents properly. We shall study these in our next lesson. Principally, among the other kinds of currents, we have alternating or oscillating current, which we mentioned quite a few times in the first six lessons of this Practical Radio Course. Your knowledge of Radio receivers is increasing quite rapidly, and with each lesson we open further into the great store of interesting information and knowledge that there is to be found in the study of Radio.

TEST QUESTIONS

Number your answers 7—2 and add your student number.

Never hold up one set of lesson answers until you have another set ready to send in. Send each lesson in by itself before you start on the next lesson.

In that way we will be able to work together much more closely, you'll get more out of your course, and better lesson service.

- No. 1. Into what two general divisions may electricity be divided?
- No. 2. Explain the action of like and unlike charges.
- No. 3. How is current electricity produced?
- No. 4. What is the difference between the effect of resistance and that of inductance in a circuit?
- No. 5. What is a kilowatt?
- No. 6. Name the instruments used for measuring different electrical values.
- No. 7. Draw a diagram showing how you would place the voltmeter and ammeter in a simple radio circuit.
- No. 8. What is the important thing to consider when connecting dry cells in various ways?
- No. 9. Draw a diagram of a series-parallel connection of dry cells.
- No. 10. What three things determine the resistance of a wire?

