

NATIONAL RADIO INSTITUTE

Complete Course in
PRACTICAL RADIO



Radio-Trician

(REG. U. S. PAT. OFF.)

Lesson Text No. 48

**PUBLIC ADDRESS
SYSTEMS**

Originators of Radio Home Study Courses
... Established 1914 ...
Washington, D. C.

Copyright 1929, 1930, 1931
by
NATIONAL RADIO INSTITUTE
Washington, D. C.

Radio-Trician's

(REG. U. S. PAT. OFF.)

Complete Course in Practical Radio

NATIONAL RADIO INSTITUTE

WASHINGTON, D. C.

PUBLIC ADDRESS SYSTEMS

Every new improvement which science provides for overcoming the age-old obstacle of distance gives another great impetus to man's knowledge and to the advance of civilization. Just as the printing press has extended learning throughout the world, as the railroad and the automobile have broadened our vision and the extent of our acquaintanceships, so Radio has brought us all into direct and personal contact with one another. The recent development of public address amplification adds still another link to the chain of modern communication—by making available to a multitude the same personalized message which heretofore could be grasped only by an individual or small collective group.

Ever since man first came into being, his steady striving has been to increase his own effectiveness. His progress has been tightly tied up with his ability to address, impress, and convert or educate, his fellowman to each new idea. Governments, whole civilizations, schools of culture and philosophy, the very civilization in which we live today, are all tightly and indissolubly bound up with the rapid and effective dissemination of ideas.

Three thousand years ago one man could address just as many other men at one time as he could at the beginning of the twentieth century—not a single forward stride had been made during three thousand or more years towards increasing the effectiveness of personal address—unless, possibly, the megaphone may be classed as a modern invention.

In the last few years man has been enabled to reach out and talk to, not paltry hundreds, but literally thousands upon thousands of other men at one and the same time. Radio has made this possible, but, like most machine inventions, has at the same time shorn the speaker of his visible personality.

Today, through public address amplification, a man may talk to, and at the same time bring the full force of his visible, physical personality to bear upon countless thousands of his fellowmen. It is today possible to be brought into the vital, living presence, and hear the unstrained natural voice of a

speaker whom a few years ago would have seemed but a straining pygmy, impossible of understanding, far away across the heads of a swaying crowd.

For instance, the minister in some architectural masterpiece of a cathedral or modern church may be preaching his Sunday sermon to an attentive congregation swelled to overflow by those anxious to hear his words. He may be old, possibly have a cold, and his voice, perhaps, is weak, though his message vital and strong. The members of the congregation in the rear pews strain forward to catch his words, while the very nooks and crannies that contribute to the beauty of the church seem to conspire to absorb and deflect his voice. We all know this sensation of straining to catch a word here and there—but how many have ever had this experience after a public address microphone, amplifier and horns have been installed, and the minister's voice comes out full and clear to even the farthest recesses.

To go to an opposite extreme—a prize fight in a large and crowded hall or stadium. With the big bout of the evening about to start, the announcer draws himself up, expands his chest and shouts an unintelligible series of names successively in four directions to a seething, whistling mass of humanity, only to stagger out of the ring, his lungs exhausted in an effort that conveyed, perhaps, only to his nearest listeners the names of the fighters. Suddenly the public address system is turned on, and in a great voice, clear and natural, the entire audience is told of the next event by a man at the ringside speaking in a low voice, into a small, round microphone. If the crowd yells and howls, up goes the volume of the unstrained voice until every last man has heard the announcement, clearly and distinctly.

Again, at a country fair a prominent citizen makes an important address. It may be heard only by a comparative few of the strolling crowd, many of whom are intent upon the exhibits. In a second, the public address amplifier is turned on, and from loud-speakers all over the fair ground issue the words of the speaker, unstrained, poised, unhurried, and, above all, clear and distinct.

A political stump speaker, traveling from ward to ward of a large city, talks to each group of constituents far into the night. If his car is provided with a public address amplifier, at each stopping point he merely has an extension cord plugged into a nearby lamp socket for power and easily, without fatigue, addresses large crowds through two loud-speakers mounted on

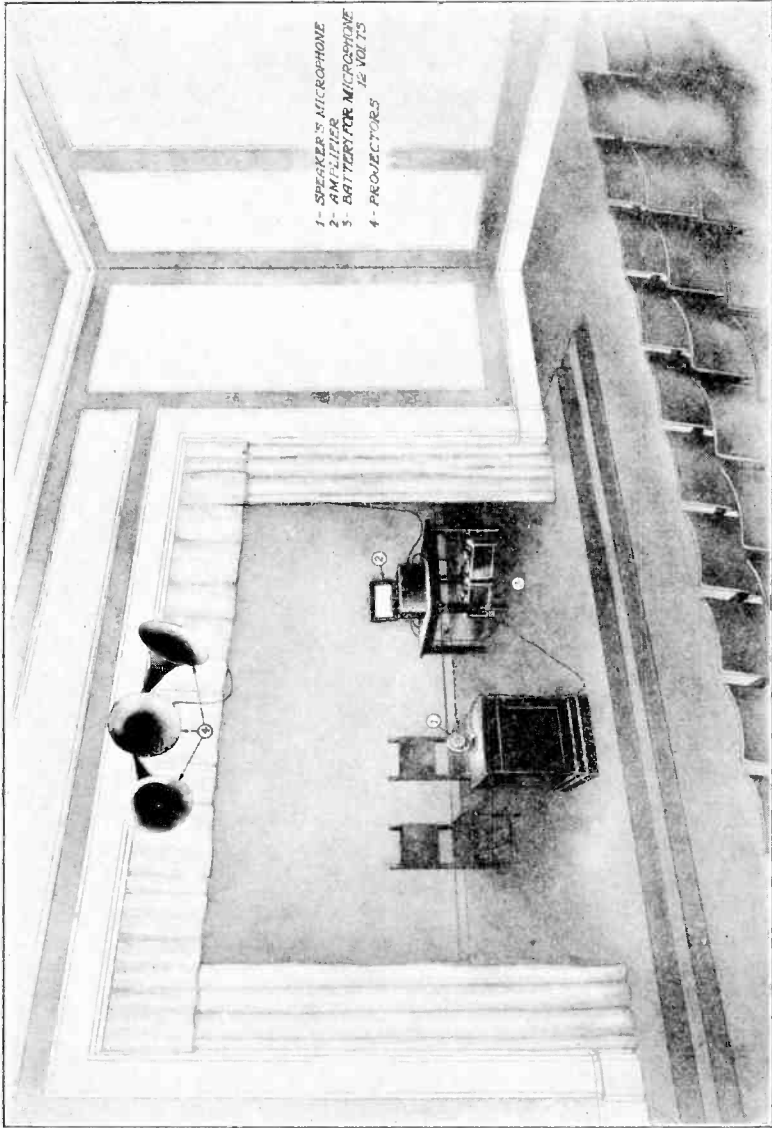

- 1- SPEAKER'S MICROPHONE
- 2- AMPLIFIER
- 3- BATTERY FOR MICROPHONE
1/2 VOLTS
- 4- PROJECTORS

Fig. 1—Typical Public Address System installed in a small hall.

the top of his car—without even having to stand on top of it—and is heard a block away!

The schools of every progressive city and township are arranging to benefit from the Walter Damrosch concerts. Here, public address amplifiers are indispensable, for no single standard radio set is powerful enough to do justice to Walter Damrosch's music in the larger classrooms. The school that installs any good Radio set, augmenting it with an address amplifier, can recreate the Symphony Orchestra's programs at full, natural, undistorted volume, either in the school auditorium, or in from ten to twelve separate classrooms, all at one time.

These illustrations serve to suggest merely a very few examples of forward strides marked by public address amplification. It is hardly necessary to add such applications as factory or office building call systems, hotel and apartment house installations; and picnic, newspaper, athletic field, and a host of similar needs which a public address amplifier can satisfy.

To our children, public address amplification will be as commonplace as the telephone is to us, and the benefits that it will confer need not be withheld a single day. Today no progressive municipality would think of building a school, community center, auditorium, fair ground, or even a hotel, without arranging for suitable amplification, for the benefits it brings are truly marvelous.

Public address systems have within the past few years enabled literally thousands to hear the voice of a speaker. This great feature, like many others, can be classified under some of the various applications of the vacuum tube.

One of the first commercial uses of the vacuum tube as an amplifier was in wire telephony. The losses encountered in the electrical transmission of the voice over a telephone line had limited the usefulness of this invention and the distance that could be covered in such cases. With the advent of the vacuum tube and understanding of its ability to amplify and exactly reproduce electrical impulses, its value in wire telephony was soon recognized. Without going into detail of this application the result was that amplifying stations were distributed along trans-continental telephone lines so that the line losses could be made up by amplifier resulting in the listener being able to hear a speaker's voice at a distant point with the usual clearness and natural volume. This all occurred before broadcasting came into

being, or rather was made use of as a public entertainment feature.

Far-sighted research engineers soon conceived the idea that it was entirely plausible to place a microphone before a public speaker or entertainer and to pass the electrical impulses created in the microphone into an amplifier and then reproduce the speaker's words in such a way that it could be heard by a vast audience. Development work was soon started along this line with the result that a speaker was able to be heard by a larger



Fig. 2—Double-button carbon microphone.

audience and in a manner which exactly reproduced his own voice.

As in a previous paragraph, the public address system consists essentially of four separate component parts: first, a microphone upon which sound waves are impressed and converted into electrical impulses varying in frequency according to the frequency of the sound waves impressed on the diaphragm of the microphone. Second, a vacuum tube amplifier consisting of several stages of audio-frequency amplification; the exact number of stages required being determined by the strength of the electrical impulses created in the microphone and the required volume of reproduced sounds. Third, reproducing units which convert the amplified electrical impulses into sound waves. Fourth, the power supply unit which supplies electrical power necessary to operate the microphone, amplifier and reproducing units.

As a further expansion on this subject, let us now go into a detailed study of the various units previously characterized.

1
27

THE MICROPHONE

The function of the microphone is to convert the sound waves impressed upon the diaphragm into electrical impulses which vary in frequency exactly as the frequency of the sound waves. Considering the fact that high quality reproduction is desired, a very high class microphone is essential. The usual broadcast or studio type microphone commonly used for radio transmission purposes is usually essential in public address systems.

The broadcast microphone is constructed along lines of research that have been developed during the period of some twenty-five years. Figure 2 shows a view of such a microphone. It is ruggedly built into a steel frame which is machined to shape. The diaphragm is of a special composition steel which is heavily gold plated. Quite a number of screws are used between the steel frames and draw the two sides of the frame together, so as to stretch the diaphragm and pull it into its correct tension. By stretching the diaphragm its tendency to vibrate at its natural period or frequency is decreased, thus avoiding the introduction of unnatural sound and the efficiency is also highly increased. Two electrodes are provided, one on either side of the diaphragm of carbon steel. The cups are of the correct size to contain the carbon and the steel edges of the cups are protected from the diaphragm by felt washers. The maximum movement of the diaphragm is permitted by the proper spacing of the cups from the diaphragm.

Most broadcast microphones will not operate in other than an upright position. The proper protection, in the form of a collar, is provided to eliminate the possibilities of damage to the diaphragm, which is ordinarily occasioned when the microphone is improperly handled. A third, or center leg of the microphone is provided on the edge of the frame, and battery connection is made thereto. There are three connections to this microphone and these connections should go to the input of a proper transformer and battery. This transformer is usually known as a modulating transformer and the schematic connections are shown in Figure 4.

High-grade microphones are constructed so that extraneous noises cause very little fluctuation of the diaphragm. Therefore the speaker or entertainer must be properly placed before the microphone. By stretching the diaphragm and by other means

these undesirable noises outside the speaker's voice are eliminated. In so doing the diaphragm does not vibrate as much as in the ordinary telephone microphone, thus the electrical impulses are much weaker and require amplification before they can be reproduced with natural volume. High-grade or broadcast microphones are usually classified as being so many "miles down." This phrase means that the electrical impulses are comparable to electrical impulses which have been sent through a standard

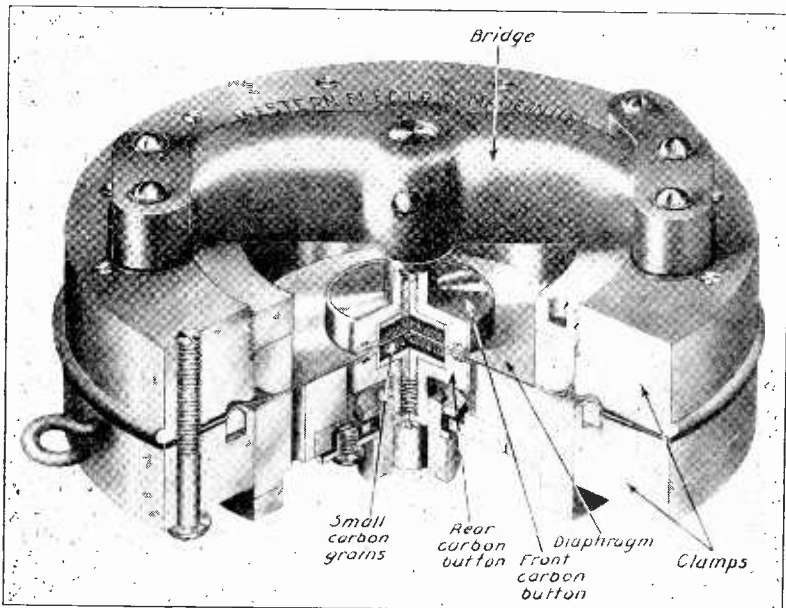

Fig. 3—Detailed construction view of Broadcast microphone.

cable of so many miles length. When transmitting electrical impulses through a very long cable such as a telephone cable, line losses occur which must be compensated for by amplification and so it is with a microphone. The ordinary broadcast microphone has a characteristic of something like "forty miles down." Roughly speaking, this means that three stages of a power amplifier will bring this up to a volume of about a person's ordinary speech. The current through most carbon microphones is in the neighborhood of ten to twenty milliamperes, the battery milliammeter and rheostat being placed in the third or center connection of the microphone. This is the total current through both buttons, there being one-half this current through each button. The direct current resistance of each button or electrode is

approximately 16 ohms. Of course, these figures vary for different types of microphones but are given so as to familiarize the student with the approximate amount.

Every broadcasting microphone should be equipped with a proper protective housing to eliminate the possibilities of damage to the microphone. The usual stand has a number of eyelets permitting the sound waves to be properly impressed upon the diaphragm. Usually springs or rubber bands are used to support the microphone inside of the stand thus doing away with undesirable vibrations of the microphone proper.

Best results are obtained from a microphone when it is used in conjunction with a modulating or microphone transformer of

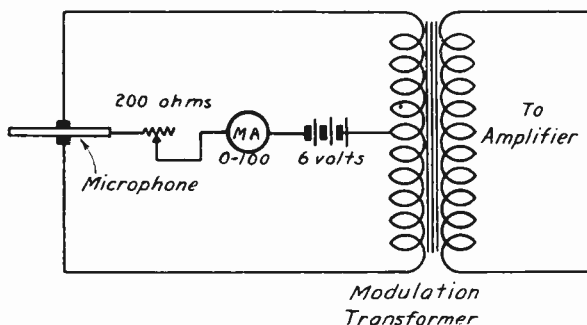

Fig. 4—Connections from microphone to modulation transformer and battery.

correct impedance. Although the impedance of the various types of microphones differ considerably, one such modulating transformer has a very large core and the complete transformer weighs about two pounds. It has an amplification curve practically even from 90 cycles upward to 5000 cycles falling off very little below 90 cycles. The primary impedance is 28,400 ohms and the secondary impedance is 390,000 ohms at 60 cycles, the primary inductance being approximately 90 henries.

It goes without saying that the secondary of this transformer is connected to the input circuit of a vacuum tube and thence so on through the amplifier proper.

MAGNETIC PICK-UPS

Under certain conditions it is desirable to supplant a microphone with an instrument whereby Victrola records can be used as the source of entertainment instead of the human voice or musical instruments. In this case a microphone is not used,

the proper instrument being what is commonly termed a Magnetic Pick-up. Practically speaking, this instrument receives the mechanical vibrations from a phonograph record and converts these mechanical vibrations into varying electrical impulses. Once these varying electrical impulses have been obtained, the problem then becomes the same as in the public address system—that is, they are amplified and then reproduced.

There are a great number of magnetic pick-ups on the market but in general they follow the same principles of construction. In Figure 5 is shown the details of the construction of a simple type of magnetic pick-up.

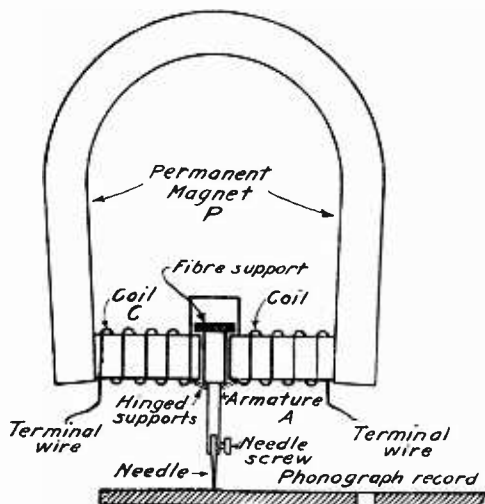

Fig. 5—Details of construction of a magnetic pick-up.

It is a fundamental principle of electricity that when a coil of wire is cut by a changing magnetic field, a voltage will be set up in the coil which changes in direct proportion to the manner in which the magnetic field is changing. This induced voltage causes a current to flow through the coil when the circuit is completed. Applying this principle, then, to the present problem, we can easily understand the operation of this unit. First, we must have a needle bearing upon a phonograph record so as to receive the changes of impressions on the record. By referring to Figure 5 it will be noted that the needle is attached to an armature which is hinged. When the needle follows the impressions of the record, the armature is caused to move. The armature is mounted between the electromagnets or coils "C." A permanent magnet "P" is mounted with the electromagnets at

Fig 5 X

its terminals. The permanent magnetic field formed by the permanent magnet "P" is distributed whenever the armature "A" is in motion. The permanent magnetic field passing through the coils "C" does not cause any current to flow but the moment the magnetic field is disturbed the lines of force change and cut the coils "C" causing a current to pass through these coils which is in direct proportion to the manner in which the armature "A" disturbs the permanent magnetic field. The current in the coil "C" is then passed into a proper amplifying transformer, the secondary of which is connected to the input circuit of a vacuum tube amplifier. This instrument performs a somewhat similar action to the microphone.

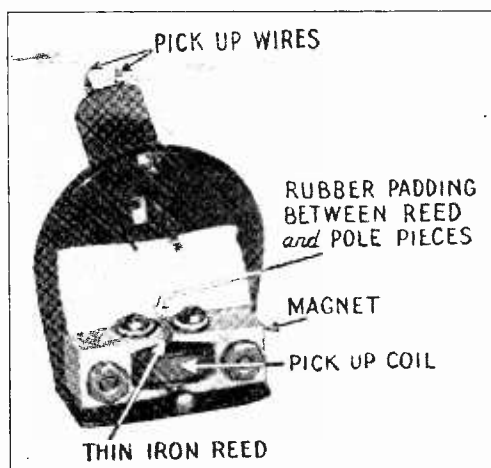

Fig. 6—A typical magnetic pick-up unit.

Due to the friction caused by the needle bearing upon the phonograph record a scratchy sound will prevail unless precautions are taken to eliminate it. In most cases a scratch filter is used to eliminate this undesirable sound. While the connection of a small fixed condenser such as .006 mfd. connected across the output of the pick-up or input to the amplifier will remove this noise, such an arrangement would also remove many of the higher audio-frequencies and lower the quality of reproduction. For this reason an electrical filter circuit, tuned to stop the passage of only those currents in the neighborhood of the scratch frequency, is used.

The difficulty in completely eliminating the scratch lies in the fact that the scratch frequency is not any one frequency, but quite a wide frequency band. If, however, the filter circuit is

tuned to approximately 4500 cycles, the greater part of the scratch noise is removed without the sacrifice of tone quality. The residual hiss, when the scratch filter is employed, is practically unnoticeable and cannot be detected except for the first few seconds or so before the music starts.

Figure 7 illustrates the connection for one form of scratch filter. In this case the inductance "L" is a 1500-turn honeycomb coil, the capacity "C" is a .008 mfd. fixed condenser. This filter is tuned to approximately 4500 cycles and will eliminate a greater majority of the scratch frequencies.

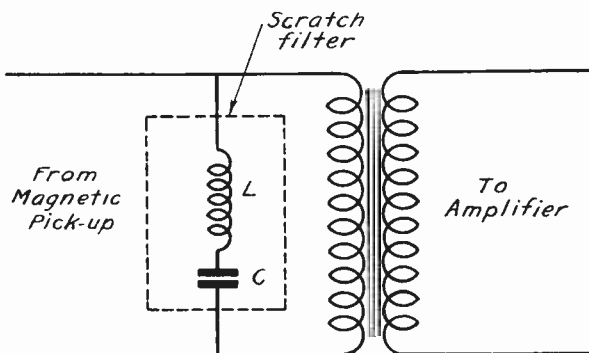

Fig. 7—Scratch filter connections.

AMPLIFIER

The amplifier used in a public address system is purely an audio-frequency amplifier. Since the frequency of the electrical impulses lies within the limits of the so-called voice frequency, all that has been learned of audio amplification in the past can be applied in this instance.

Instead of having the output voltage from the detector, we merely have the voltage developed in the modulation transformer.

Since the microphone is rated as several miles down, it is necessary to use two or three stages so as to amplify the electrical impulses and have the reproduction of normal speech volume. Then, if several loud-speakers are to be operated, power amplification must be used so as to increase the volume above the normal amount. Therefore, it becomes apparent that the number of stages in the amplifier depends upon the type of microphone used and the volume of the desired reproduction.

For a small hall where one or two loud-speakers will suffice, only two or three stages without power amplification may be used. Where great volume is required in a large assembly hall

or for reproduction in the open for a multitude, the number of stages must be increased accordingly. Each loud-speaker requires a certain amount of power to operate, and taking this into consideration, the amplifier must be designed accordingly. In large public address systems power tubes having an output rating as high as 50 or 200 watts are often used. Every installation is an individual problem which must be dealt with accordingly.

REPRODUCING UNIT

Ordinary loud-speakers will generally accommodate requirements for a small public address system. One power speaker may be used to deliver a greater amount of volume, but for a large assembly hall or for open-air reproduction several such speakers may be required. The acoustic condition of the hall or surrounding country must be taken into consideration and the speaker placed accordingly. The echo effects and reverberation usually cause considerable trouble and in such conditions the best policy is to use several ordinary speakers instead of a power speaker and place them in such a manner that the echo effect is minimized.

In some cases a number of ordinary speakers are grouped and in such cases as the National Conventions in an exceedingly large assembly hall, groups of these speakers are placed at various points throughout the hall. Usually considerable experimentation is required in order to determine the correct locality of each group of speakers. Also, the echo and reverberation effects will vary considerably when the hall is filled with people as compared to being empty; more echo usually being present when the hall is empty. However, more volume is required when the hall is filled with people.

As in the case of the amplifier, the exact number of speakers may be compared to the exact number of stages of amplification by saying each installation presents an individual problem and must be solved usually by experimentation in order to determine the best conditions.

A KIT FORM ADDRESS AMPLIFIER

The Silver-Marshall 685 Unipac, public address type amplifier, is available in two styles. Type 685 WIRED is furnished completely wired and tested by the factory; the same instrument can be obtained in kit form, ready to assemble and wire.

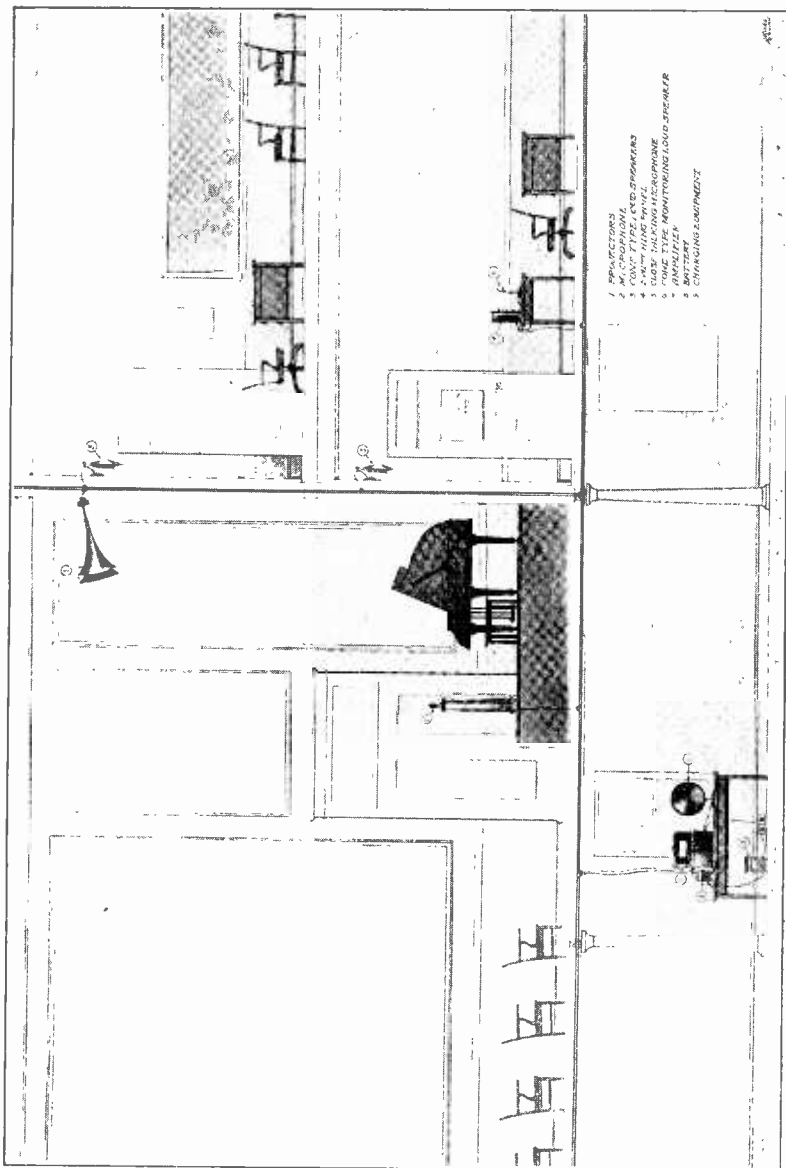

Fig. 8.—Typical school installation.

The 685 Unipac is a light-socket operated power amplifier drawing all power from any 105 to 120 volt, 60 cycle, alternating current source. It will amplify the output of a microphone, magnetic phonograph record pick-up, or the output of a Radio set detector tube up to an undistorted power level of 5 watts. This power will give intelligible high quality speech and music through one to six large loud-speakers for auditorium, theater, church or

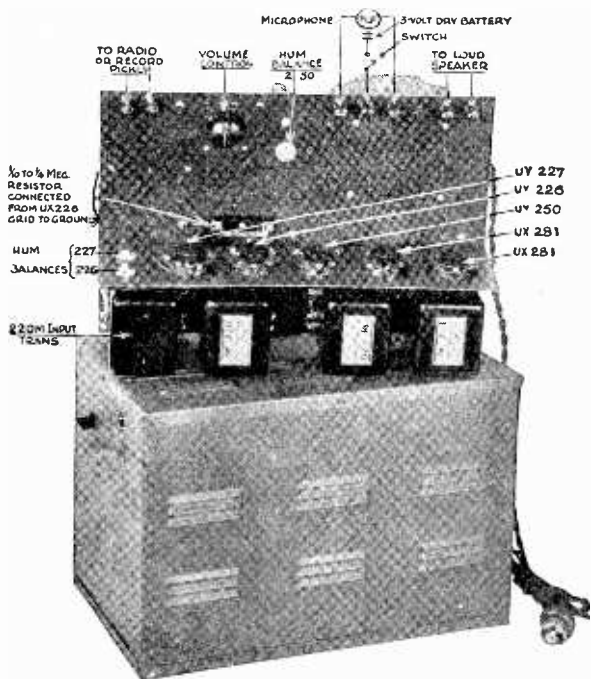
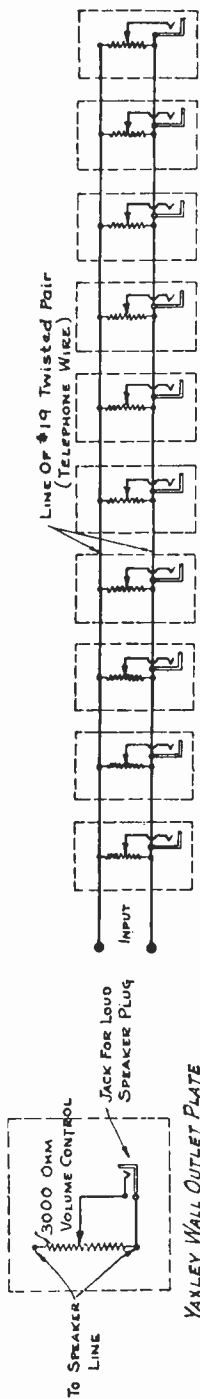

Fig. 9—SM 685 Unipac. All tubes are mounted on the shelf as shown, with amplifying transformers below. The bulk-head assembly is shown on top of its steel housing cabinet.

outdoor grandstand coverage for 2,000 to 10,000 people. This output will also handle up to twelve standard Radio loud-speakers at ordinary home volume, with the speakers located in different rooms of a building, as in a hotel, school or apartment house. Loud-speakers may be located up to 500 feet away from the Unipac; connections from microphone, Radio set or pick-up should be as short as possible and not over 50 feet long. A control knob is provided to regulate volume smoothly from a whisper to full maximum.

The Unipac apparatus is mounted upon a heavy steel bulk-head, to which a tube socket shelf is attached. This assembly



YAXLEY WALL OUTLET PLATE AND VOLUME CONTROL
 Price \$2.25

TYPICAL LOUD-SPEAKER LINE OF 10 OUTLETS.

Fig. 10—Method of connecting one to twelve loud speakers in different rooms, with independent volume controls.

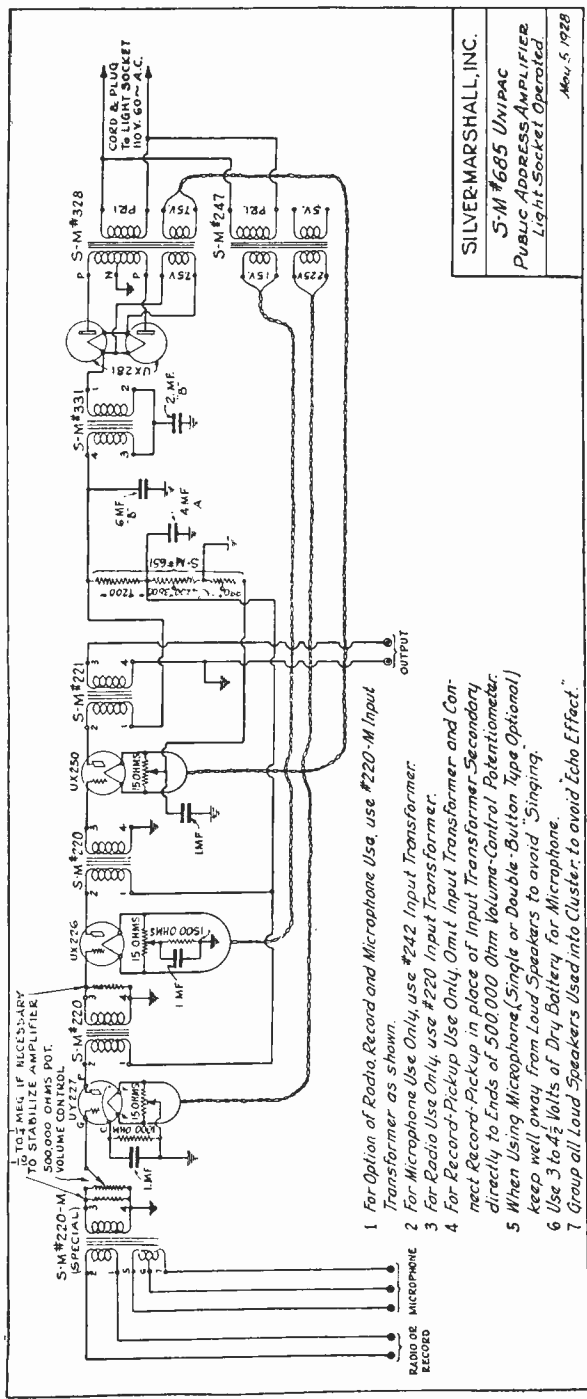

- 1 For Option of Radio, Record and Microphone Use, use #220-M Input Transformer as shown.
- 2 For Microphone Use Only, use #242 Input Transformer.
- 3 For Radio Use Only, use #220 Input Transformer.
- 4 For Record-Pickup Use Only, Omit Input Transformer and Connect Record-Pickup in place of Input Transformer. Secondary directly to Ends of 500,000 Ohm Volume-Control Potentiometer.
- 5 When Using Microphone, (Single or Double-Button Type Optional), keep well away from Loud Speakers to avoid "Singing."
- 6 Use 3 to 4 1/2 Volts of Dry Battery for Microphone.
- 7 Group all Loud Speakers Used into Cluster, to avoid "Echo Effect."

SILVER-MARSHALL, INC.
 S-M #685 Unipac
 Public Address Amplifier
 Light Socket Operated
 May 5, 1928

is fastened in the center of a brown crystalline finished steel case provided with a hinged cover over tube compartment, ventilating louvres and two carrying handles. Binding posts are provided for loud-speaker, Radio or record pick-up, microphone and microphone battery connections. The Unipac weighs approximately 70 lbs., and is 17½" long over carrying handles, 9¾" wide, and 10½" high, with cover closed. It may be used as a portable amplifier or permanently installed either indoors or outdoors. If instantaneous changeover from Radio, record or microphone amplification is required, external switching is necessary, as described under "Input Switching."

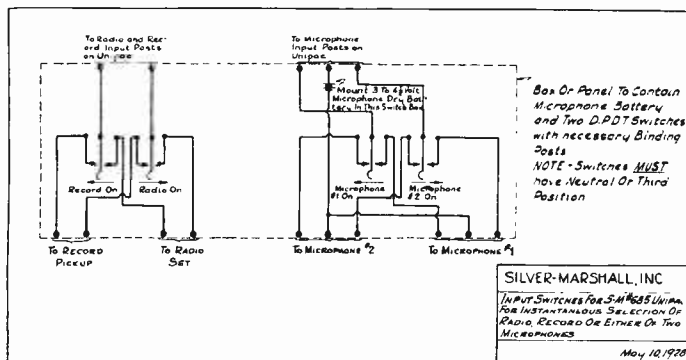

Fig. 12—Switching arrangement for microphone and pick-up.

Two UX281 rectifiers, one UX250 power amplifier, one UX226 A. C. amplifier and one UY227 A. C. amplifier tubes are required for operation, in addition to input apparatus and loud-speakers.

DIRECT CURRENT OPERATION

When an alternating current lighting circuit is not available to operate the Unipac, but a 110 to 120 volt DC lighting circuit is at hand, a small rotary converter may be used, such as an Esco, Janette or Bodine machine of at least 200 watts rating.

OPERATION

First completely unpack and inspect the 685 Unipac. Place the R. C. A. tubes listed below in the sockets, from left to right, in the order given. Equivalent Cunningham tubes may be used.

One One One One One
 UY227 UX226 UX250 UX281 UX281

Turn the volume control knob all the way to the left. Insert

the attachment plug in any 105 to 120 volt, 60 cycle, A. C. lighting socket, and turn on power at the socket. Within fifteen seconds the "V" or "W" shaped filaments of all tubes should heat to a cherry-red color, excepting only the UY227 tube. Within one minute the round central rod inside this tube should attain a dull cherry-red color.

No blue glow, or at most very faint traces of blue around the metal structure of UX250 and UX281 tubes should be observed. With power turned off, connect the loud-speaker to the two "SPEAKER" binding posts. Switch the power on again and allow a minute for tubes to heat to operating temperature. A low-pitched A. C. hum should then be heard at the loud-

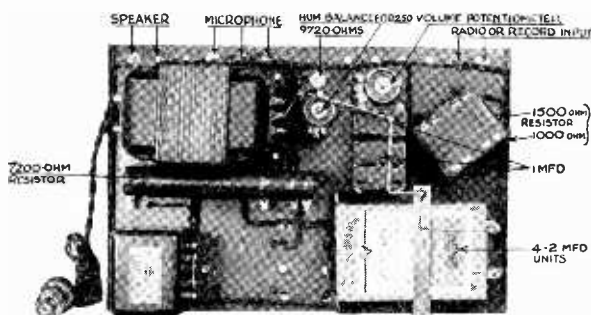

Fig. 13—View of power transformer filter, etc.

speaker. This hum must be balanced down to a minimum value for each location in which the amplifier may be used.

Balancing is done with a long screw-driver wrapped with friction tape so that the metal shank cannot touch the metal carrying case. The screw-driver is used to adjust the three slotted screw-heads, labeled "HUM BALANCE" in the photos, to the point of minimum hum. Two are on the left end of the tube shelf, the third on the bulkhead behind the UX250 tube. This operation should be carefully repeated with the volume knob set at the half-way position. A certain amount of hum will always remain, but so little as not to interfere with auditorium or outdoor use. Make sure the grid resistor is in its clip; either a $1/10$ or $1/4$ megohm resistor, whichever is necessary to reduce the hum to the desired point without losing amplification.

A magnetic record pick-up should be connected to the two left-hand "INPUT" binding posts and a record played. Volume should be adjusted by the volume knob on the bulkhead to a

point where music is audible several hundred yards from the speaker. Similar results should be obtained if the same pair of Unipac "INPUT" posts are connected to the output of a radio receiving set detector tube, assuming a good strong signal to be used for this test.

If a double-button microphone (Kellogg No. 501 or equal) is connected to the three right "INPUT" posts, with a 3-volt dry battery and a battery type cut-off switch connected between the center binding post and the center wire from the microphone, good speech should be obtained. If the microphone is too near the loud-speaker, or volume is turned up too far, "singing" will occur.

A lower priced hand microphone (Kellogg No. 21-C, equipped with cut-out button switch) can be used for announcements, if preferred, connecting it in series with a 3-volt dry battery to the center and one of the outer "INPUT" posts of the group of three at the right.

The following paragraphs deal with the use of the 685 public address Unipac for different classes of coverage, with suitable accessories. It is well to emphasize the fact that satisfactory public address operation may not be had by merely installing equipment without thought and trial, and expecting it to work perfectly. Each installation requires individual experimentation over a period of several days or even several weeks, for upon the carefully worked out and tested placement of loud-speakers and microphone depends the degree of satisfaction that will be had.

SCHOOL, APARTMENT, BUILDING, ETC.

Where a 685 Unipac is to be used to operate up to twelve loud-speakers in different rooms of a building, the loud-speakers should be connected as shown in Figure 10. For each loud-speaker one Yaxley or equivalent single wall outlet plate, carrying a 3,000 ohm wire-wound potentiometer and open-circuit jack should be provided. For one to six speakers, the standard S-M 221 output transformer is correct. For six to twelve speakers, the special S-M type 221-D low impedance output transformer should be used in the Unipac instead of the standard 221 type. This arrangement will provide ample volume for home or classroom purposes, with independent volume control at each speaker outlet, and a substantially constant volume level, whether one or twelve outlets are in use.

AUDITORIUM, THEATRE, ETC.

For auditorium or theatre use, one or two large speakers, such as the 36" cone speakers, may be used, placed close together, or not over ten to fifteen feet apart at most. Through careful trial, the speakers should be so tilted and directed as to give intelligible speech and music throughout the auditorium. This arrangement will suffice for a hall not over half again as long

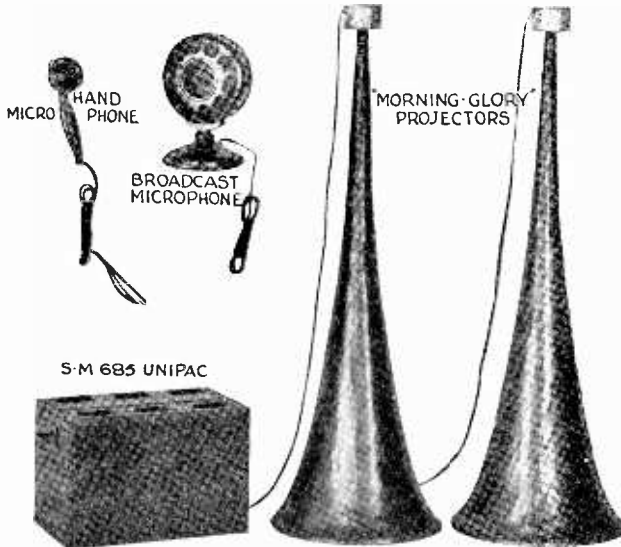

Fig. 14—A typical portable Public Address Amplifier System which will give voice coverage of from one to five thousand people. It consists of a microphone, either hand or broadcast type, three dry cells (not shown), the 685 Unipac amplifier, and two "morning glory" projectors. Up to twelve speakers could be used, and the amplifier would reproduce phonograph records upon the addition of a small portable phonograph equipped with a record pick-up. It can also be operated from a radio set at will.

as it is wide, though for a very large hall (say 100x150 feet) three or more speakers might prove necessary.

If dynamic speakers are preferred they may be used if of the low voltage, trickle-charger-operated-field type. If two speakers are used, series and parallel connections should be tried. Three speakers should be connected in parallel; four, in series-parallel. **Speakers should be so placed that the microphone, if one is used, is always well behind a line crossing the speaker faces or radiating openings.** For auditorium installation, as in a church to intensify a preacher's voice, only a double-button type of microphone should be used, and the loud-speakers should be swung

above the speaker's head, and far enough away to allow the desired volume to be obtained without "singing."

LARGE HALLS OR OUT-OF-DOORS

For a very long hall, or outdoor use, the long horn-type speaker is often preferable (of the "morning-glory" type) since the sound waves can be radiated away from the microphone and in any desired direction. A typical installation for a hall 100x200 feet, with the speaker's rostrum at one end, would consist of a cluster of four "morning-glory" horns ten feet or more above the speaker's head, two horns pointed at the far end of the hall, and two pointed at the middle of the hall and diverging slightly. With the microphone located five to ten feet behind the loud-speaker mouths, "singing" should not be troublesome. The effect gained will be a realistic intensification of the speaker's voice—not the development of so much volume that the whole impression gained is of an inhumanly loud and artificial voice.

OUT-OF-DOORS

The above suggestions are applicable for voice coverage of a baseball park or similar gathering. Generally, cone speakers are preferable for high quality, with "morning glories" used only to avoid "singing" due to the loud-speaker reaction on the microphone; or in order to project sound waves in one direction. When voice coverage is not needed, and radio or record coverage only is desired, cone or dynamic speakers are to be preferred. Speakers should never be left out of doors for long periods, for dampness will deteriorate them. When installed out of doors an adequate canopy must be provided to protect them from rain and dampness. Microphones must be most carefully protected from moisture.

VOICE ANNOUNCEMENTS AND SPEECHES

For occasional voice announcements to be made between musical selections a hand microphone is quite good enough for intelligible speech. For amplification of entire speeches or addresses, where high quality is desired, the double-button microphone should be used, and a switch provided to cut off the microphone battery when not in use.

INPUT SWITCHING

With the standard 685 Unipac, either Radio, record, or microphone inputs may be amplified. When one source is being

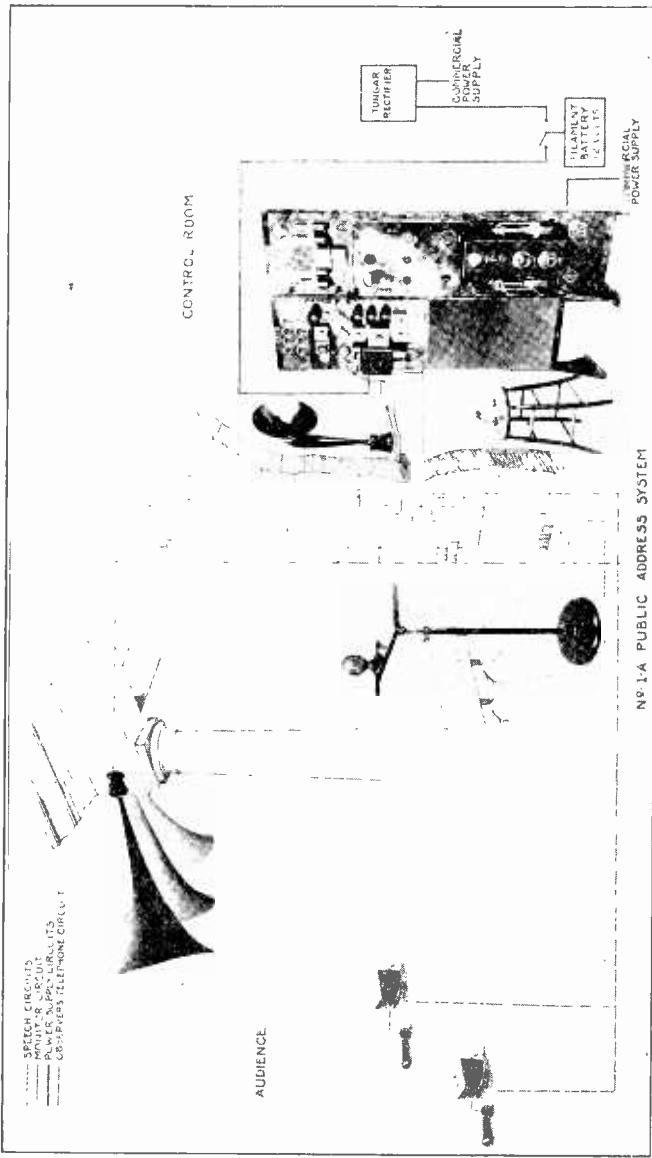

Fig. 15—Typical installation of W. E. No. 1A system.

used the others must be disconnected from the Unipac. It frequently becomes desirable to have either microphone, voice, or record inputs available instantaneously, and at a uniform volume level. A switching circuit is shown in Figure 12 to accomplish this. It consists of two D. P. D. T. (double pole double throw) key switches (Federal, Yaxley or Carter), arranged to cut the three inputs in or out. The microphone switch is shown as a D. P. D. T. type, with connections for two microphones, should they be needed. In this arrangement the volume control in the Unipac is used as a master control for all three classes of input. Radio volume is controlled at the set, record volume by the control accompanying the pick-up, and voice volume by a 5,000 ohm variable resistor across the microphone (a simple and fairly satisfactory method for the volume levels used). A separate panel or boss carrying the switches would have to be constructed.

WESTERN ELECTRIC PUBLIC ADDRESS SYSTEMS

The Western Electric Company, on account of its experience in the telephone field, naturally became one of the pioneers in the development of a public address system. Having already applied speech amplification to the transcontinental and other long distance telephone communication, this company was in a good position to pioneer this work. In fact, they were one of the earliest to introduce the public address amplifier.

Several such units have been developed to take care of varying conditions and small, intermediate and large audiences. The Western Electric public address systems No. 1A and 2A are for use when and where the audiences are large. The No. 3A system was developed for use where smaller audiences were to be dealt with. No. 4A public address system is a small portable outfit for use in small or moderate size halls or auditoriums, schools, churches and similar places.

THE W. E. NO. 1A PUBLIC ADDRESS SYSTEM

The Western Electric No. 1A public address system is the largest piece of equipment made for this purpose and is designed for use with the largest audiences, outdoors or indoors. It is adapted for either permanent or temporary installation. The efficiency of this system was first brought to the attention of the public during the inauguration ceremonies of the late President Harding in 1921 when, by its use, an audience of more than

125,000 people, gathered before the National Capitol at Washington, was enabled to hear distinctly the President's Inaugural Address. The same system was used in 1925 when President Coolidge was inaugurated and also during the National Conventions of 1924 and 1928. In Figure 15 is shown a typical installation of the 1A public address system.

Considering the amplifier panel, the upper left-hand portion is the volume control panel supplied for use in connection with

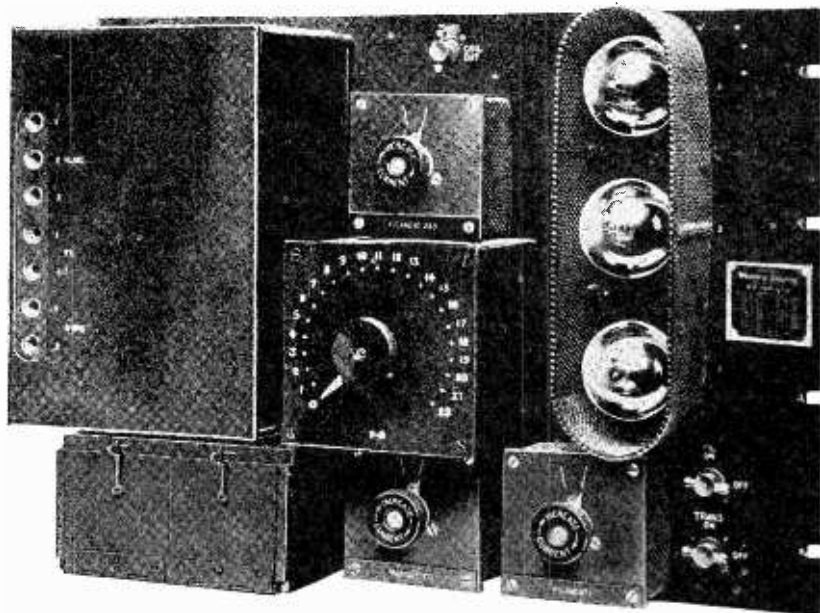

Fig. 16—View of three-stage 8B amplifier panel.

the amplifying equipment. It provides a means for adjusting the volume of sound from the different groups of speakers to fit the acoustics of the parts of the auditorium which they cover. By means of adjusting the rheostat knobs, it is possible to regulate the power supplied to the various speakers or projectors. Just below the volume control panel is the volume indicator panel. The meter on the extreme left of this panel gives a visual indication to the operator of the output volume of the system.

Next comes the 8B amplifier panel. This is more clearly illustrated in Figure 16. The amplifying equipment receives the speech frequency currents and amplifies this energy to a level high enough to permit its distribution through the loud-speaker projectors to the audience. It provides three stages of amplifica-

tion and makes use of three vacuum tubes, one type 102-D having a very high amplification constant, and two 205-D type having a low amplification constant but a much greater power output. The amplifier is provided with suitable controls for regulating the amount of amplification.

In the upper right-hand portion of the main panel illustrated in Figure 15 is the 10A amplifier panel. It receives the amplified voice currents direct from the 8B amplifier. It supplies a single stage of amplification but makes use of four of the 211 type power tubes. These tubes operate on the push-pull principle, two tubes in parallel on each side of the circuit. The output of the 10A amplifier is controlled by the amount of energy received from the 8B amplifier.

The two lower panels in the right-hand portion of the main panel shown in Figure 15 are the power control and the rectifier panels respectively.

THE W. E. NO. 2A PUBLIC ADDRESS SYSTEM

Though somewhat smaller than the No. 1A system, the 2A system is capable of taking care of large crowds either outdoors or indoors. The No. 2A system is at present being widely used in auditoriums and hotel banquet halls throughout the country. A typical installation of the 2A system is shown in Figure 17.

The main amplifier panel is shown at bottom of picture. It will be noticed that this main panel is very similar to the main panel of the 1A system. However, it does not include the 10A amplifier using four 211 power tubes in push-pull fashion. It uses a 9A amplifier instead. This is a single stage power amplifier consisting of two 205-type vacuum tubes operating on the push-pull principle, handling a comparatively large amount of power at voice frequencies without distorting the complex wave form of the voice currents.

THE W. E. NO. 3A PUBLIC ADDRESS SYSTEM

A typical installation of the 3A public address system is shown in Figure 19. This system is suitable for use in auditoriums, the cubical contents of which do not exceed 150,000 cubic feet: For example, an auditorium of approximately 100' by 75' by 20' high.

It will be noticed that a portable amplifier is used with this type of apparatus. The whole apparatus is mounted in an oak box with the tubes and control units on a panel. On the panel are mounted four 205-type vacuum tubes and the necessary transformers, resistances, condensers, switches, etc., for three stages

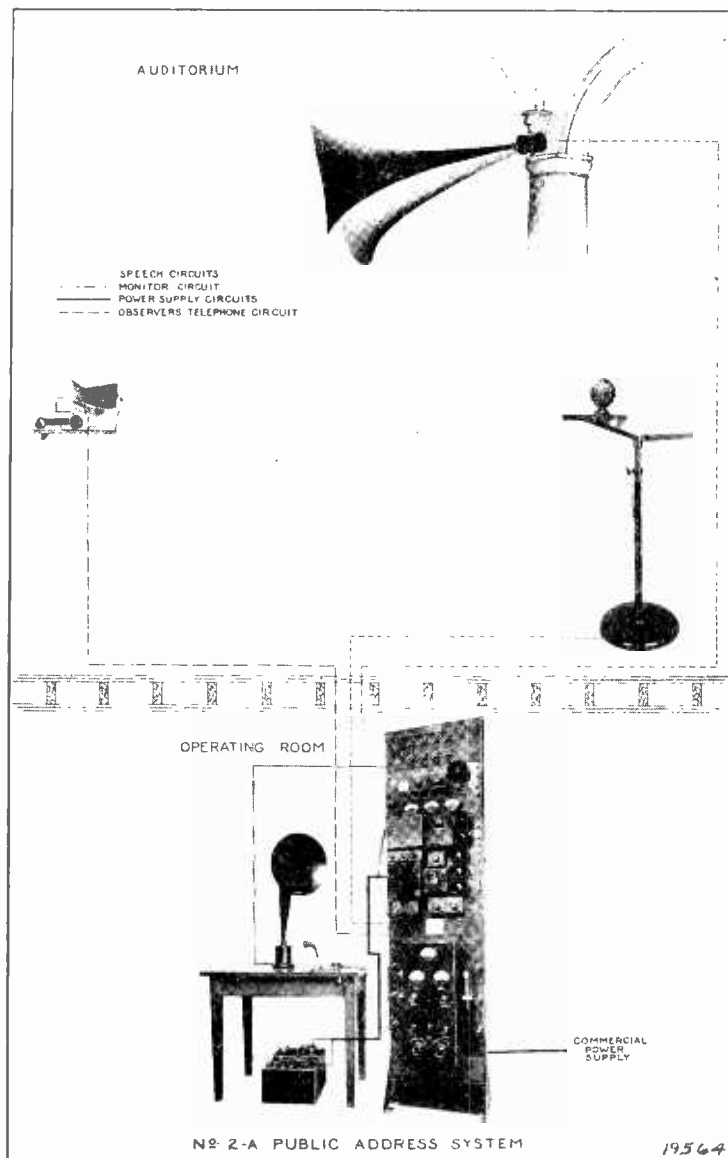

Fig. 17—Typical installation of W. E. 2A system.

of amplification. The amplifier has been especially designed to minimize frequency distortion and to obtain the requisite amplification throughout the central range of voice frequencies without sacrifice of the quality of reproduction. Two separate tubes are used in what is commonly called a push-pull circuit in order to handle amplified currents introduced into the last stage.

The volume is controlled by means of switches and keys mounted on the amplifier panel. A switch turns the filament current on and off. One key enables the operator rapidly to connect

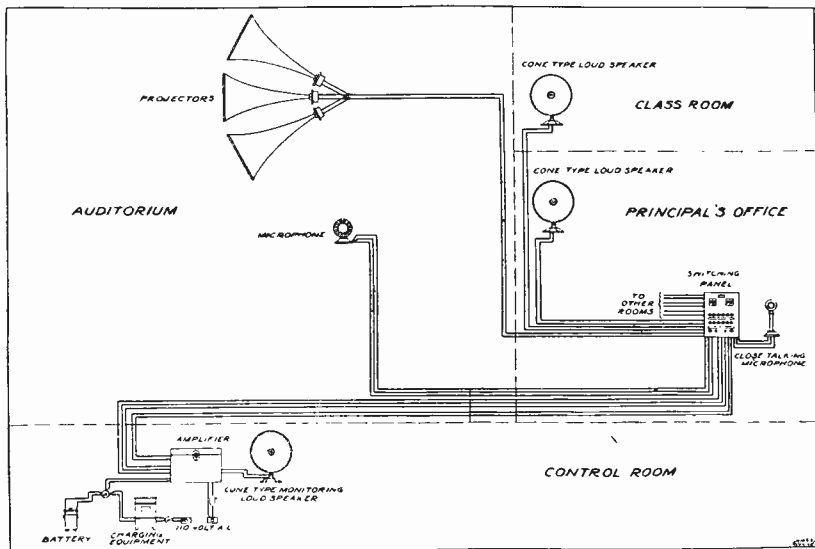

Fig. 18—Installation and wiring diagram of W. E. 4A system.

or disconnect the microphones in either of the two microphone circuits available. Another key enables him to connect or disconnect the loud-speakers without disconnecting the monitoring telephone. The volume of sound emitted is regulated by an adjustment of the amplification. This is controlled by means of a nine-point switch and a key.

THE W. E. No. 4A PUBLIC ADDRESS SYSTEM

A typical installation of the 4A is shown in Figure 18. The 4A system is the smallest of the Western Electric public address systems and is of the portable type. Figure 20 illustrates the portable amplifier and the apparatus mounted below the panel. This is a four-stage amplifier and is operated by the commercial

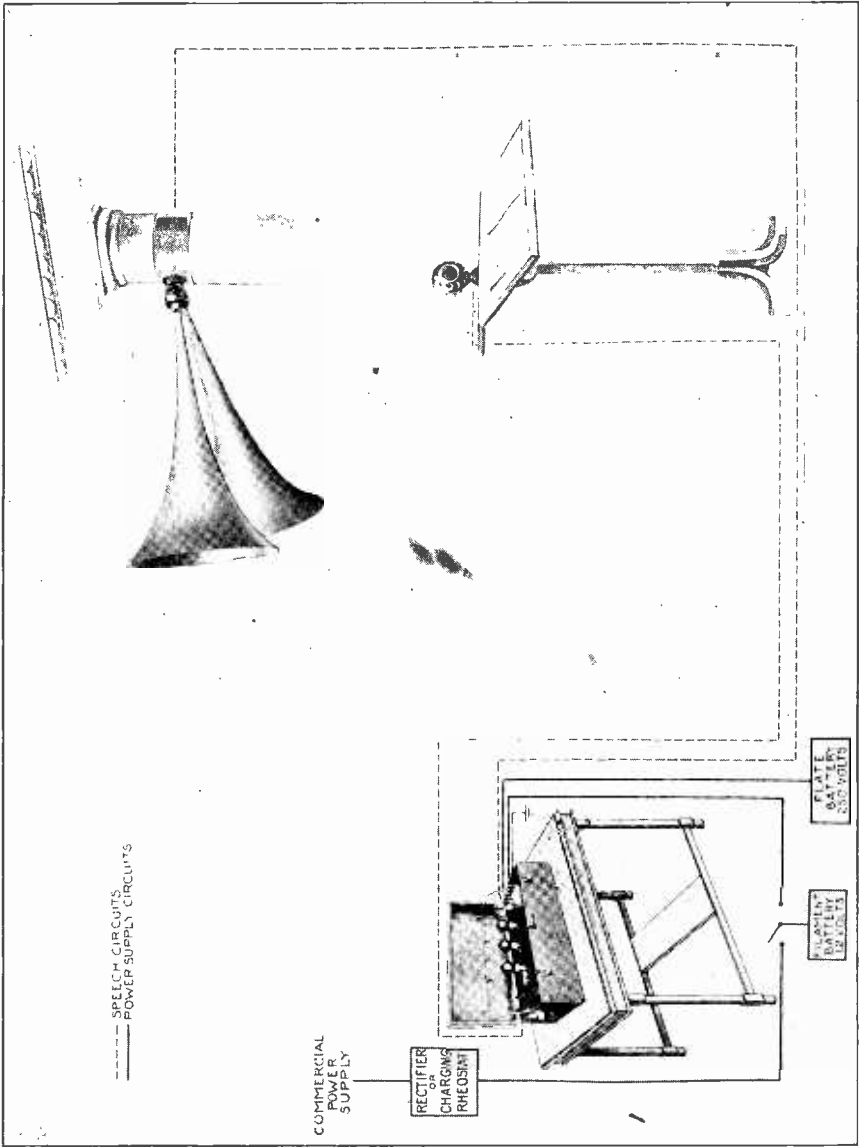

Fig. 19—Typical installation of W. E. 3A system.

lighting circuit which supplies plate current for all the vacuum tubes, and filament current for the tube in the last stage and for the rectifier tube in the current supply set contained in the amplifier. Filament current for the first three tubes is supplied by the battery provided for the microphone. The tubes require only 60 milliamperes at 3.3 volts on the filament. The amplifier is provided with two input circuits for the microphone. Plug

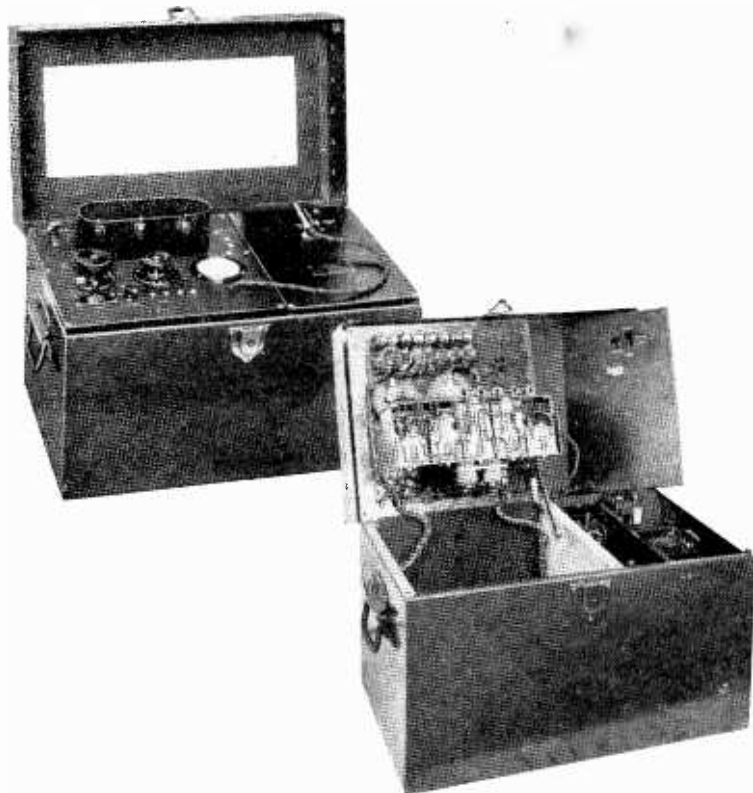

Fig. 20—Portable amplifier showing cover open and interior view.

connections are provided for connecting the amplifier to the microphone and a key is provided for switching between the microphones. Monitoring connections are also provided as well as a shut-off key for the loud-speakers.

When the operator is not located where he can judge the operation of the loud-speakers, he can monitor the program by the addition of a loud-speaker connected directly to the amplifier.

+
10

TEST QUESTIONS

Number your answers 48 and add your Student Number.

Never hold up one set of lesson answers until you have another set ready to send in. Send each lesson in by itself before you start on the next lesson.

In that way we will be able to work together much more closely, you'll get more out of your course, and better lesson service.

1. For what long felt need does Public Address Amplification fill?
2. Name the four component parts of a Public Address system.
3. What is the function of the microphone?
4. What precaution is used to prevent the microphone from jars and vibration?
5. Upon what fundamental principle does the Magnetic Pick-up work?
6. Draw a diagram showing the method of connecting a scratch filter.
7. Is the amplifier in a Public Address system for audio or radio-frequency amplification?
8. How far behind the loud-speaker should the microphone be placed to prevent singing?
9. Draw a schematic wiring diagram of the complete S. M. Address Amplifier.
10. How can an operator monitor a program when not located near the loud-speakers using WE 4A Public Address System?

