

NATIONAL RADIO INSTITUTE

Complete Course in
PRACTICAL RADIO



NRI

Radio-Trician

(REG. U. S. PAT. OFF.)

Lesson Text No. 47

**DISTANT CONTROL
BY MEANS OF
RADIANT ENERGY**

Originators of Radio Home Study Courses
... Established 1914 ...
Washington, D. C.

Success in life depends upon understanding one's capabilities. The people who achieve the greatest and most satisfying success in life are those who pursue vocations to which they are best adapted.

Copyright 1929, 1930
by
NATIONAL RADIO INSTITUTE
Washington, D. C.

Radio-Trician's

(REG. U. S. PAT. OFF.)

Complete Course in Practical Radio

NATIONAL RADIO INSTITUTE,

WASHINGTON, D. C.

DISTANT CONTROL BY MEANS OF RADIANT ENERGY

The present state of development of distant control by means of Radio, like a great many other branches of the art, is due to the early experiments and farsightedness of some of the inventors and scientists who have followed the growth and development of Radio in all of its various branches. The dreams of the inventor and scientist and some of his experiments are generally performed some years before the invention is so perfected and developed that its practical application can be made use of. Such is the case with distant control. Prior to the time when trans-Atlantic communication was first carried on by means of Radio, Nikola Tesla foresaw the usefulness of distant control by means of Radio and performed numerous experiments along this line. In 1895 he gave demonstrations in New York of his radio-controlled boat. This small boat was only 8 ft. long, but it was entirely controlled by Radio, and operating it in a large pond, the inventor made the boat go through many maneuvers such as turning lights on and off, firing miniature guns, changing its course at will, all to the consternation of the public to whom Radio was then practically unknown.

Following the successful application of Radio communication by commercial companies, other scientists and inventors turned their attention to the development of distant control. John Hays Hammond, Jr., has developed and invented several systems of distant control and his inventions have done a great deal toward making this branch of the art successful. One of his earliest inventions, the so-called "electric dog," could be made to follow the rays from a flash-light or electric-light bulb, and it performed many complex maneuvers in so doing. It was simply necessary to keep the source of light close enough to the "eyes" of the "electric dog" to cause a sufficient amount of light to get through to the sensitive cells within it, which functioned to translate the light into electrical energy, the latter being used to operate the control relays within the device.

A more serious application of this principle was effected in tests which were carried on during the late war, for controlling torpedoes by Radio or light waves. This system was so arranged that, should an enemy ship at night, try to watch out for these radio-controlled torpedoes by means of powerful searchlights, the Radio control operator could release control of the torpedo in such a manner that the moment the beam from the enemy searchlight became focussed on the torpedo, the latter would immediately change its course and travel in the direction of the source of light, subsequently striking the ship upon which the searchlight was mounted, thus destroying or at least disabling the enemy ship that was causing the interference. It was thought that this action of the torpedo would soon discourage the enemy from attempting to interfere with these radio-controlled torpedoes and the Radio control operator was given further leeway, in that it was made possible for him to release, or regain control at will. He could also make this device free from, or subject to, enemy interference, as desired, by the manipulation of the proper controls at the remote controlling station.

Here then was a useful application of the invention. The course of the torpedo could be accurately controlled by Radio, from a remote point, and it could be made entirely free from enemy interference, or could be made to travel toward the source of the interference, if there was any, and destroy this source.

The "electric dog" embodies the basic principle of the action involved in the control of a moving body by radiant energy and though the radiant energy in this particular case is light, and not Radio, it is worth while for the sake of making the fundamentals clear, to give it first consideration. The action is not at all involved as it makes use of well established scientific principles and is merely a new application of these principles.

Figure 1 shows the Hammond "electric dog" being controlled by means of a portable 50-watt lamp held in the hand of an operator, and Figure 2 is the schematic wiring diagram showing the circuits involved in the operation of the control mechanism. The basic unit in this device is the light cell; this cell is sensitive to light, in that its internal impedance to the flow of an electric current varies with the amount of light striking its sensitive surface. It is a two-electrode device that requires a potential in the order of 300 volts (in the case of the potassium cell) between its electrodes for satisfactory action.

Hammond used the type of cell that is called a "selenium cell," in the "electric dog," but there is another cell, of a different type, known as the potassium cell which is more sensitive than the former.

Considering Figure 2, the light from the source O-3 will pass through the condensing lens L-1 and strike the sensitive surface of the selenium cell S-1 within. This cell, S-1, is connected in series with a battery and the coils of the sensitive relay R-1. Before any light strikes the cell, there will not be any flow of current from the battery, due to the fact that the impedance of the cell is infinitely high. When light reaches the



Fig. 1—Photo of the Electric Dog

sensitive surface of the cell, the internal impedance of the cell immediately drops to such a value that sufficient current flows through the light cell circuit to operate the relay R-1.

The tongue of this relay goes over to contact No. 1 thus closing a circuit from the battery B-3 through the field coil of the solenoid R-3. The armature of this solenoid moves upward, closing contact 3-4 and 5-6. This action closes the circuit through one field of the motor M. The battery B-5 is connected directly to the armature at all times and this battery B-5 is also con-

nected to the field in question through the contacts of the solenoid R-3. Hence, when R-3 functions, the motor M rotates, and it rotates in such a direction that it turns the control wheel to which it is geared so that the "dog" tends to move toward the light.

You have probably noticed, in looking at Figure 1, that the "dog" is a three-wheeled affair. It has two front wheels and one rear wheel and it is by the latter that the direction of travel is controlled.

Let us now assume that we have the source of light at O-2. The rays from this source pass through the condensing lens L-2 and strike the sensitive surface of a second selenium cell S-2. When the light is at O-2, the rays do not reach the sensitive surface of the cell S-1 due to the light screen between the two light cell compartments just as in the case of the source at O-3, the light does not strike the cell S-2.

The action of the light striking the cell S-2 causes current to flow through the output circuit of this cell and the coils of the relay R-2, are energized. The tongue of this relay closes contact No. 2 and a circuit is closed through the field coil of a solenoid R-4. The armature of this solenoid moves upward closing the contact 7-8 and 9-10. The closing of these last named contacts, completes the circuit through the other field winding of the control motor and due to the fact that in this case, the flow of current through the motor field winding is in the opposite direction to that when the source of light was at O-3 and the relay R-3 closed to operate the control motor, the motor will rotate in the opposite direction and the rear wheel of the "electric dog" will be turned in such a direction that the device will move towards the source of light which is now at O-2.

Now considering the last case. If the source of light is at O-1, there will be sufficient light reaching both selenium cells to produce enough current in their output circuits to operate their output relays R-1 and R-2, and both of the solenoids R-3 and R-4 will function to close the contacts 3-4, 5-6, 7-8, and 9-10. If you trace the circuit through under these conditions you will find that the two motor fields are in parallel and there will be an increased current flow through R-5 due to the shunting of the two motor fields and the increased flow of current will be sufficient to operate the solenoid R-5, the armature of which will move upward cutting additional resistance in the circuit to limit the

current flow by means of a rheostat control connected to the armature of R-5. You will now recall that in all previous cases, the current was so limited by the control motor field winding that it was not of sufficient value to operate the solenoid R-5.

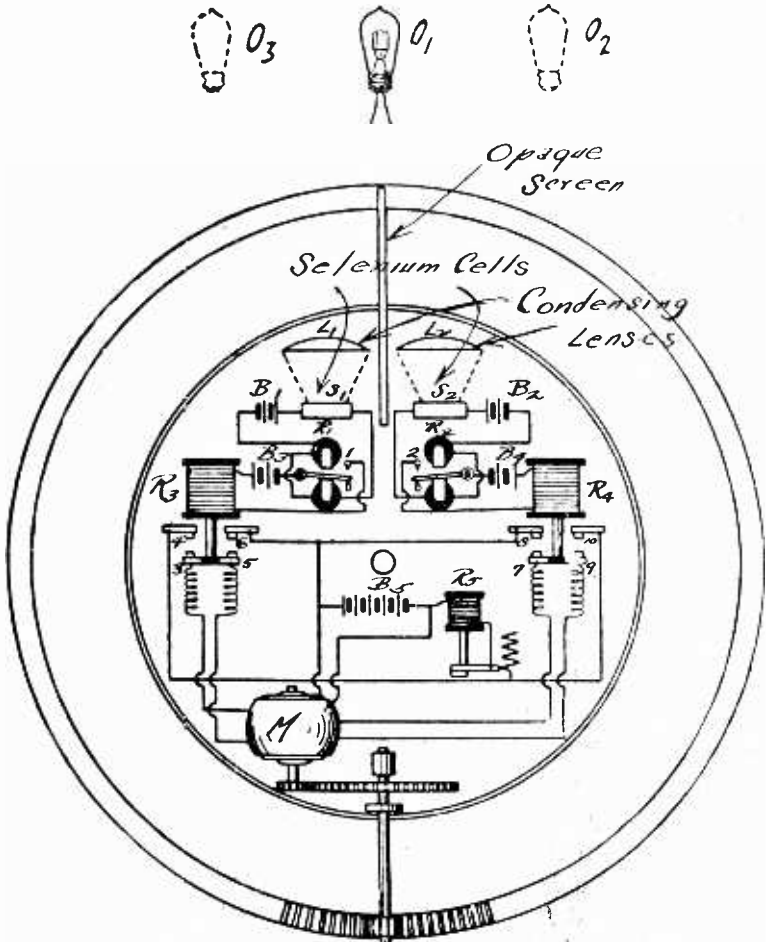

Fig. 2—The schematic wiring diagram showing circuits used for controlling mechanism of the Electric Dog.

We should mention the fact here that the schematic wiring diagram in Figure 2 only takes into account the mechanism which controls the direction of travel of the "electric dog" and it should be mentioned that whenever either relay R-1 or R-2 closes, there is an auxiliary set of contacts which function to close the circuit through a driving motor which puts the device in motion.

In the device shown in Figure 1, the speed of travel was 3

ft. per second and in the smallest circle that it could turn in was 10 ft. in diameter.

RADIO CONTROL OF SHIPS AT SEA

Figure 3 is a schematic wiring diagram which shows the circuit involved in the distant control of a ship at sea. This diagram is the one that appeared in Hammond's original patent and is really the basic circuit for the control of ships, aircraft, vehicles or torpedoes.

We will now first consider the action involved in Radio or distant control and for the sake of variety, we will assume that in this case we are controlling the course of a ship at sea from a point on the land. Referring to Figure 3, you will notice two closed loops 1 and 2 at right angles to each other, instead of the two selenium cells, and the energy that is picked up to actuate the control mechanism is radio energy, instead of light rays. It is assumed that you understand the directive characteristics of the closed loop antenna as well as the fact that the phase of the oscillations received in the loops varies according to the relative positions that the loops bear to the transmitting antenna.

The value of the negative charge on the grids 10 and 11 is a function of the amount of the energy stored in the condensers, which in turn is a function of the relative position of the loop with respect to the source of radio-frequency energy. This specification drawing shows the grids 10 and 11 as both contained in one vacuum tube having as well two plates and one filament. It is true that this tube could be a special tube having two grids, two plates and one filament, but it is more logical to believe that in actual practice, two separate tubes would be used, one functioning from the energy stored in the condenser 3 and the other functioning from the energy stored in the condenser 4.

The potential for the plates 14 and 15 is supplied from the battery 12 through the differential windings 16 and 17 of the differential relay 18. These windings are so arranged that the current from the battery 12 to the plate 14 will create a field in the winding 16 in opposition to that produced in the winding 17 when current is flowing to the plate 15. In other words, the plate current to 14 causes the armature of the differential relay to move in one direction and plate current to 15 causes the relay armature to move in the opposite direction.

A summary of the foregoing shows that the position of the

armature 19 of the differential relay 18 depends upon whether the field due to the plate current to 14 or the field due to the plate current 15 through the relay windings 16 and 17, respectively, predominate and this in turn is a function of the charge

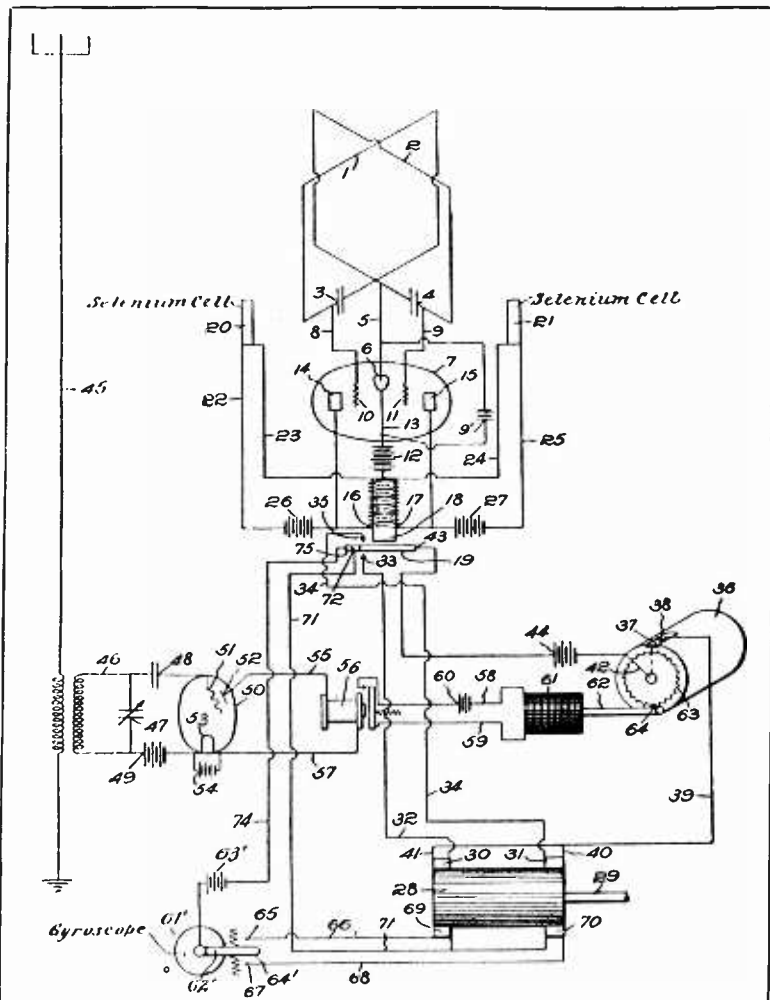

Fig. 3—Schematic wiring diagram showing circuits used for distance control of a ship at sea.

of the respective grids due to the energy in the condensers 3 and 4 which in turn is a direct function of the relative position of the loop with respect to the sending station's antenna.

With this brief explanation as to how the movement of the armature 19 is controlled by means of the radio-frequency energy

from the transmitting station, let us assume that the energy comes in such a direction that the armature is pulled towards the relay core causing 19 to make contact with 35. When this takes place, a circuit may be traced from the battery 44 to the armature 19 through the contact 35, through the conductor 34 to the valve mechanism 31 through the conductors 40 and 39 to the brush 38, through the contact 37 and conductor 42 to the negative side of the battery 44. The completion of the circuit just traced operates the valve mechanism 31 which admits compressed air to one end of the cylinder 28 and exhausts it from the other end. Within this cylinder there is a piston 29 which is attached to the rudder of the ship, thus the movement of the ship's rudder is affected, and the amount of movement of the latter depends on the amount of compressed air that is admitted to one end of the cylinder and this in turn depends upon the length of time that the armature 19 remains on contact 35 which in turn is a function of the position of the loop relative to the transmitting antenna.

Let us say, that this movement of the rudder changes the course of the ship to such an extent that the other loop picks up more energy and the armature 19 is pulled downward, closing the contact 33. The closing of this contact completes a circuit from the battery 44 in the same manner as the circuit traced through above, but this time it passes through the valve mechanism 30 which admits compressed air to the opposite end of the cylinder 28 and exhausts it from the end to which it was admitted in the previous case. This means that the piston 29 will now move in a direction opposite to that in which it moved before and the rudder of the ship will also move in the opposite direction and the course of the ship will again be changed. If the ship is moving in a direction such that it receives an equal amount of radio-frequency energy in each of the loops, the armature 19 will remain in a neutral position, touching neither contact 35 nor 33, and the rudder of the ship will remain unchanged, hence, the course of the ship will also remain unchanged.

The selenium cells 20 and 21 function the same (where light is the radiant energy used for control) as the loops function, where radio is an agent or control. The output circuit of cell 20 is completed through the battery 26 and the differential relay winding 16 and the output circuit of cell 21 is completed through the battery 27 and the differential winding 17. Hence, at night.

if the beam from a powerful searchlight were turned on the ship, the armature 19 would move either up or down depending upon which cell received the greatest amount of light, and it follows that the ship's rudder would in turn be controlled by this movement of the armature 19.

If it so happened that the control operator wished to release control of the ship, he could send out a radio-frequency signal on a predetermined wave-length on an auxiliary transmitter. This signal being picked up by the antenna system 45 and subsequently induced in the closed circuit tuned by the condenser 47 and applied to the grid of tube 50 would cause a corresponding change in the current to the plate of the tube sufficient to operate the relay 56. It should not be assumed that there is only one tube used between the antenna system 45 and the relay 56 because this is not necessarily correct. We are simply endeavoring to make the basic principles of this system clear and in so doing have shown only one tube, 50, between the antenna system 45 and the relay 56. However, there might be half a dozen tubes used, depending upon how great a degree of sensitivity was desired. For instance, say there is a modulated wave sent out from the transmitting antenna. Let us assume that this modulation is affected by superimposing a 1000-cycle audio-frequency on the radio-frequency carrier wave. If the vacuum tube (50) were used as a detector tube, there would be a minute alternating current, having a frequency of 1000 cycles in the detector output circuit. This 1000-cycle alternating current would be amplified through several stages of audio-frequency amplification and the last stage of this amplifier could be coupled to a rectifier stage which would function to change the alternating current (1000 cycles) applied to its input circuit, into a direct current, the latter appearing in the output circuit of the rectifier tube and being applied to the windings of the relay 56. There could be a couple of stages of radio-frequency amplification, a detector and three stages of audio-frequency amplification if necessary.

Now let us summarize. If the key of the auxiliary transmitter were pressed down, three times, there would be three trains of radio-frequency waves sent into the ether, modulated at 1000 cycles. This radio-frequency energy would be picked up by the antenna system 45, induced into the closed circuit tuned by the condenser 47, detected, amplified and rectified and the pressing of the transmitter key three times would be mani-

fested in the receiver rectifier output circuit by three pulses of direct current which would energize the relay 56 three times, thus drawing its armature over a like number of times. This last action would cause the closing of the circuit through the windings of the relay 61, having a core, adapted to impart step by step rotations to the commutator 36 by means of the ratchet 63 and the pawl 64 arrangement.

This movement of the commutator 36 would open the circuit closed by the brush 38 and contact 37 which would immediately prevent any action on the rudder to the movement of the armature 19, the latter being controlled by either radio or light by means of the two loops and the two selenium cells. This would mean that the direction of the ship could no longer be controlled by either radio or light and would continue on a course controlled by the gyroscope 61', this course having been previously determined. This gyroscope would continue to control the course of the ship until such time as the proper number of dashes were sent out by the auxiliary transmitter. This would cause the commutator 36 to be rotated into such a position that the brush 38 and the contact 37 again make contact thus allowing the ship's course to be controlled by either radio waves picked up from the two loops, or light rays intercepted by the two selenium cells.

It should be noted that the control by the gyroscope can only be effected when the armature 19 of the differential relay is in a neutral position. As has been stated before, one time, that this will occur, is when radio and light controls are released by the sending of the proper number of dashes on the auxiliary transmitter. When this happens (the armature 19 in neutral position) there will be a circuit closed by the end of the armature 72 making contact with 75. The armature 72 is a part of the armature 19 but is insulated from the latter. When 72 and 75 make contact there is a circuit that can be traced from the positive terminal of the battery 63', through the conducting arm of the gyroscope 62' and out through either terminal 65 or 67. Let us say that the conducting arm is in such a position, due to the operation of the gyroscopic compass, that the conducting arm makes the contact with 65. The circuit is traced from this point through the lead 66 to the valve mechanism 69 which functions the same as the valve mechanism 30. Continuing with the circuit, it is traced from the valve mechanism 69

through the lead 71, the end of the armature 72, the contact 75, and back to the negative side of the battery 63'.

If the conducting armature of the gyroscope 62' is in the opposite direction, it will make contact with terminal 67 and the battery current will pass through the valve mechanism 70 which functions the same as the valve mechanism 31.

From the foregoing explanation you can see how it is possible to start a torpedo on a predetermined course by means of the gyroscopic control, take control away from the gyroscope by means of the auxiliary transmitter, control the movement of the torpedo by radio, allow the torpedo to be controlled by light so that it would then tend to move in the direction of an enemy ship, should the searchlight from the latter be played on the torpedo.

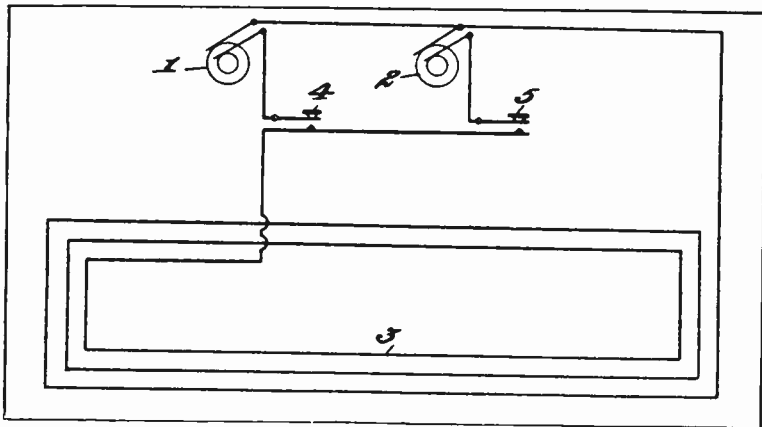

Fig. 4—Fundamental principle upon which the Hanson system of control operates

THE HANSON SYSTEM

The Hanson System of distant control makes use of the generation of different frequencies so as to manipulate the controls of the distant object.

Figure 4 shows the fundamental principle upon which this type of control operates. In this figure you will notice two audio frequency alternating current generators 1 and 2; the output of these generators is impressed on the loop 3 by means of suitable controls such as keys 4 and 5. Generator 1 is a 3000-cycle type and generator 2 is a 6000-cycle type. By closing key 4 a 3000-cycle note is impressed upon the antenna 3, while closing key 5 impresses a 6000-cycle note on the loop. Any number

of generators may be used with this system to control the distant object.

The arrangement of the receiving apparatus on the craft to be controlled is shown in detail in Figure 5. A loop antenna 6 is used to intercept the passing waves. The output of this loop is connected to the primary winding 7 of a transformer shown and numbered 8. The secondary winding 9 of this transformer is connected to the input circuit of a vacuum tube 10. The output of this vacuum tube is connected to the primary winding 11 of another transformer 12. These transformers 8 and 12 should be of the iron-core type and should respond to the band of frequencies used. The secondary winding 14 of the second transformer is connected to the input circuit of another vacuum tube 15, the plate circuit of which is connected to the electromagnets 16 and 17. These magnets are provided with tuned reeds 18 and 19 which are adapted to be operated selectively by the energy sent out by the transmitter shown in Figure 4.

The battery 21 is connected to the reeds 18, 19 at the point 18-A and 19-A. It will be noticed that this battery furnishes current through the winding of the electromagnets 22 and 23.

If the operator at the transmitting station closes the key 4, for example, the 3000-cycle generator 1 will transmit radio energy which can be intercepted by the loop antenna 6 of the receiving set, and the receiving energy will be amplified by the vacuum tube amplifier and will cause the reed 19 adjusted to respond to 3000 cycles, to vibrate, which will cause the contact 25 to be broken, thereby releasing the armature 29 of the electromagnet 23. This operation permits the contact 30 and the armature 29 to be closed, thus energizing a power relay 27, which permits current from a battery 33 to energize the motor 32 in such a manner as to cause the shaft 34 to rotate. The shaft 34 as shown is provided with a bevel pinion 35 which meshes with the secondary rack 36, which is connected by a bar pivoted at 37 and supports the rudder 38. Rotation of the shaft 34 which follows the energizing of the magnet 23 in the manner above described will be in such a direction as to cause the rudder 38 to move in a given direction, thereby controlling the course of the craft. The extent of the turning movement of the craft will depend upon the amount of rotation that the shaft 34 makes before its rotative movement is arrested by the release of the control key 4 at the transmitter.

If the operator at the transmitter desires to reverse the direction in which the craft is turning, he releases the key 4 and presses the control key 5. The loop antenna of the transmitter will then be energized by the 6000-cycle generator 2. This fre-

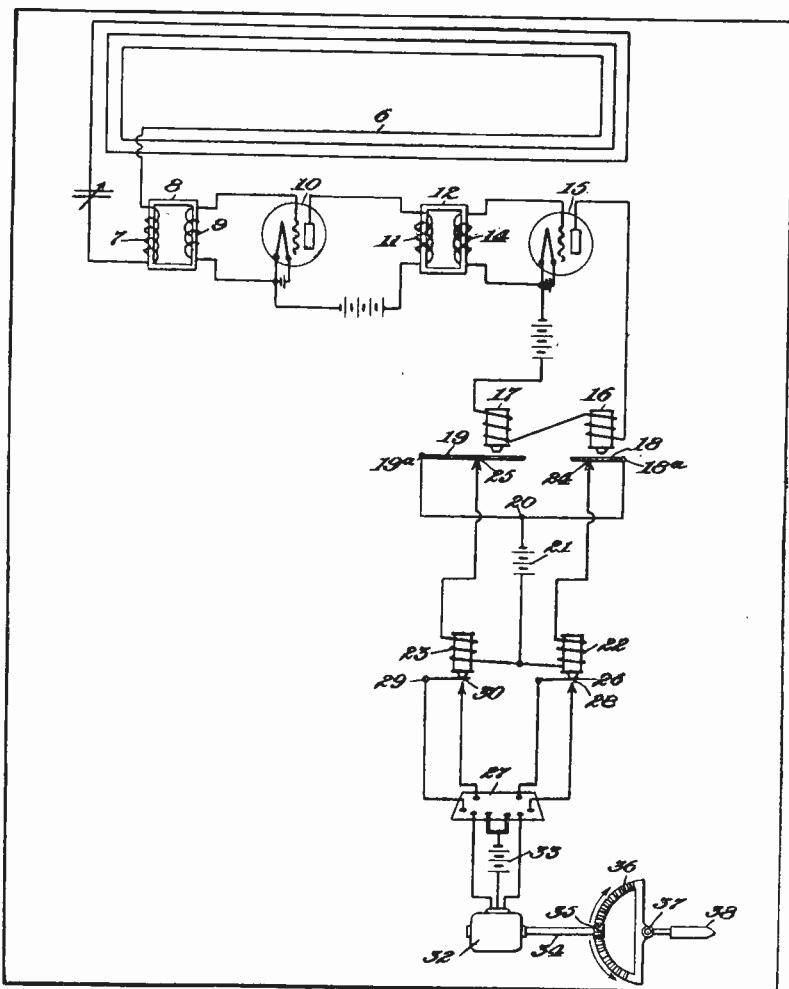

Fig. 5—Wiring diagram of receiving apparatus used on the craft to be controlled

frequency will in turn be impressed upon the receiving loop and the signal will be passed through the vacuum tube amplifier. This 6000-cycle frequency in passing through the electromagnet 16 will cause the reed 18 to be actuated and in turn so control the relay 27 as to cause the shaft 34 of the motor 32 to rotate in a direction opposite to its direction of rotation which followed the

closing of key 4. This will reversely operate the secondary rack 36 causing the rudder 38 to move in a direction opposite to that which was caused by closing the control key 4.

Figure 6 represents a torpedo carrying the receiving apparatus. The receiving loop antenna is shown at 6 with the lead passing through an insulator 40 and connecting to the winding of the input transformer 8 just as shown in Figure 5. The torpedo 39 may be constructed so as to enable the loop antenna to be arranged in a groove in order to preserve the stream-line effect of the torpedo.

Figure 7 shows a schematic view of how the transmitter is mounted on an airplane. The alternating current generators 1 and 2 are mounted on the airplane so as to be driven by small propellers. The loop 3 is mounted underneath the lower surface in such a manner as to cause the least wind resistance possible. The control keys 4 and 5 are mounted close to the operator so

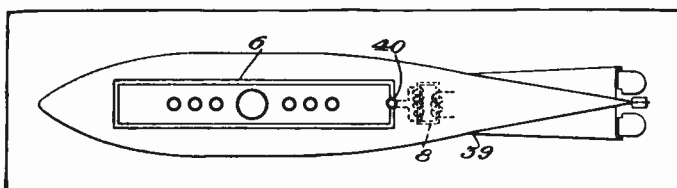

Fig. 6—A torpedo in which is installed the receiving apparatus

that they are easily within his reach and can be operated quickly.

It is not absolutely necessary that the transmitting apparatus be mounted on an airplane, but in this way it is possible for an observer to follow the controlled craft and observe closely its movement. This system is primarily designed to be used in controlling the movement of ships and torpedoes from airplanes, however, it can be adapted to other uses.

Neither is it necessary to use the frequencies mentioned in this description as the alternating current generators may be replaced by vacuum tube generators and frequencies much higher may be used. By using higher frequencies the range will be increased considerably and the size of several pieces of apparatus will be reduced accordingly. However, it must be taken into consideration that the frequencies cannot be increased too high on account of the fact that it will be impossible to use mechanical reeds for selecting the various frequencies such as is done in the scheme shown in Figure 5. There is a limit to the

frequency at which mechanical reeds can vibrate and if the frequency is increased beyond this point it will be necessary to use other means of selecting the received frequencies.

U. S. NAVY TESTS OF DISTANT CONTROL

The U. S. Navy Department in conjunction with Hammond engineers conducted some very interesting tests in regard to distant control of battleships. The transmitting and control apparatus was placed on the U. S. S. Ohio and the U. S. S. Iowa was fitted out and equipped so as to be controlled entirely by radio signals sent out by the U. S. S. Ohio.

Some very unique features were developed during these tests which have important bearings upon distant control. The tests covered a period of several months and it was found that it was

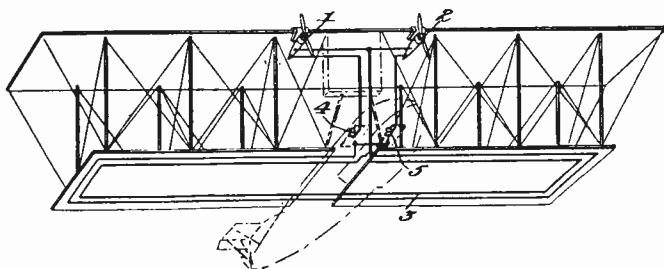

Fig. 7—Schematic view of how the transmitter is mounted on an airplane

possible to completely control a battleship entirely by signals sent out from another ship. The ship was started and stopped at will and caused to take a given course and continue in this course or change its course whenever desired. Guns were fired and various other duties performed just as if it were manually controlled.

The main object of these tests was to determine whether radio control was possible and just how much interference would be experienced and how serious this interference would be in the control of the ship. The greatest amount of interference was encountered due to static. The system of control depended upon the length of the dashes sent and the combination of dots and dashes to perform the various actions of controlling the ship. Therefore, with this in view, any outside or extraneous noises impressed on the output of the receiving apparatus would have a very serious effect upon the control of the ship. This was overcome to a certain extent by using a submerged trailing

antenna. This trailing antenna was a lead-covered high-tension cable and completely insulated from the water and suspended some 2 or 3 feet below the surface of the water. By the use of this antenna a certain amount of the strays and static interference was overcome and control could be accomplished in a much more satisfactory manner.

By using these antennas, the danger of having them shot away by gun fire or bombs was obviated to a certain extent. However, it was thought advisable to use more than one antenna so as to lessen this chance of having the antenna destroyed. The apparatus used was very similar to some of the other systems used by Hammond and covered by his patents. All of the data regarding these tests is not obtainable for publication, however, the general lay-out and the general principle is herewith described.

6 The receiving apparatus consisted of six stages of tuned radio-frequency together with the usual detector and two stages of audio-frequency amplification. The wave-length used in transmitting these signals was in the neighborhood of 1500 to 2000 meters. Figure 8 shows a view of the receiving equipment. The output of the audio-frequency amplifier is connected to a polarized relay. This relay can be seen in the right-hand portion of Figure 8. The output of this relay is then connected to several time relays which are actuated by the length of the signal and the combination of the dots and dashes received. These relays select the signal which is then sent to a commutator as shown in Figure 9. The function of this commutator is to make such connections and control a greater amount of power. As shown in this figure, there are six different controls and circuits and when a signal is received it passes through the receiving equipment, through the relays which select the signal and pass it to this commutator. This commutator is then placed in a position so that the springs on the right-hand side and left-hand side make contact through the cams. As this current is very much greater than the received current, it is used to control the various motors for steering, starting and stopping, and other controls necessary.

Figure 10 shows a view of the complete cabinet in which the receiving equipment was located. You will note that springs were used so as to damp the vibrations present. This was found necessary in order to prevent the jarring of the receiving equip-

7

7
ment by gun-fire and other vibrations present in the receiving set. This cabinet was located in the lower part of the ship so as to protect it as much as possible from gun-fire as well as to give it a more stable construction. The whole cabinet was suspended

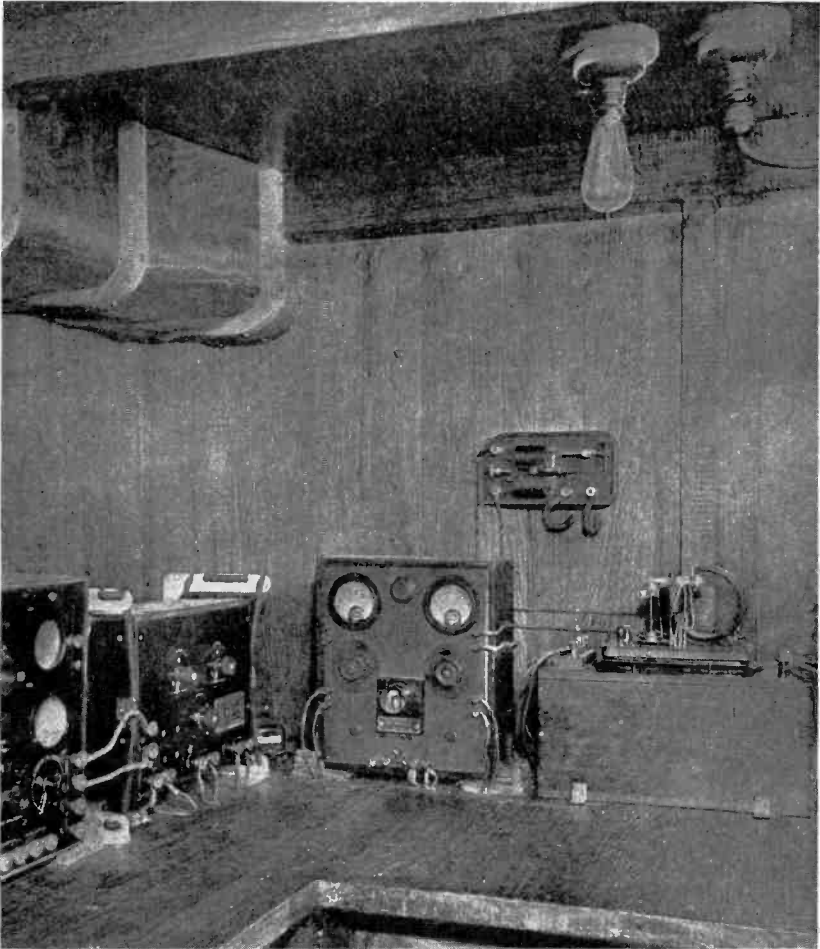

Fig. 8—View of the receiving apparatus installed on the U. S. S. Iowa

from the steel girders by means of the springs and you will note the springs are also attached to the bottom of the cabinet and on all sides so as to make this as near shock-proof as possible.

It was found that it was possible to completely control the U. S. S. Iowa from a ship located as far as 200 or 300 miles distant. However, in most cases, the controlling ship, U. S. S.

Ohio, was located much closer than this. The speed of the propelling motors could be reduced in less than one minute, but in most cases it was possible to make all other adjustments and controls within less time or within a corresponding time according to the operations performed. The speed used in most of these tests was in the neighborhood of 10 or 12 knots per hour

8

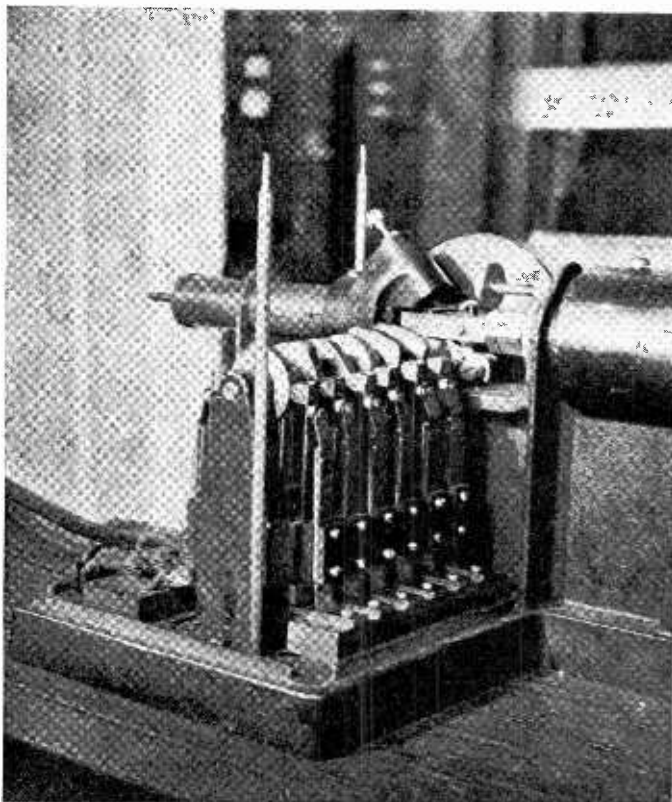

Fig. 9—Photo of the commutator described in the text

and it was found that with this speed it was possible for the U. S. S. Ohio to completely circle the U. S. S. Iowa and at the same time maintain complete control over it.

As a result of these tests it was found possible to completely control the movement as well as the other actions required of a battleship. However, static and strays would undoubtedly cause serious interference and hamper the control. For controlling moving targets, radio control was feasible and

practical and the interference caused by static and strays was not so serious as to render the system unreliable and impracticable. With the perfection of apparatus more suitable for this purpose, distant control will be much more satisfactory and applicable for use in the Navy.

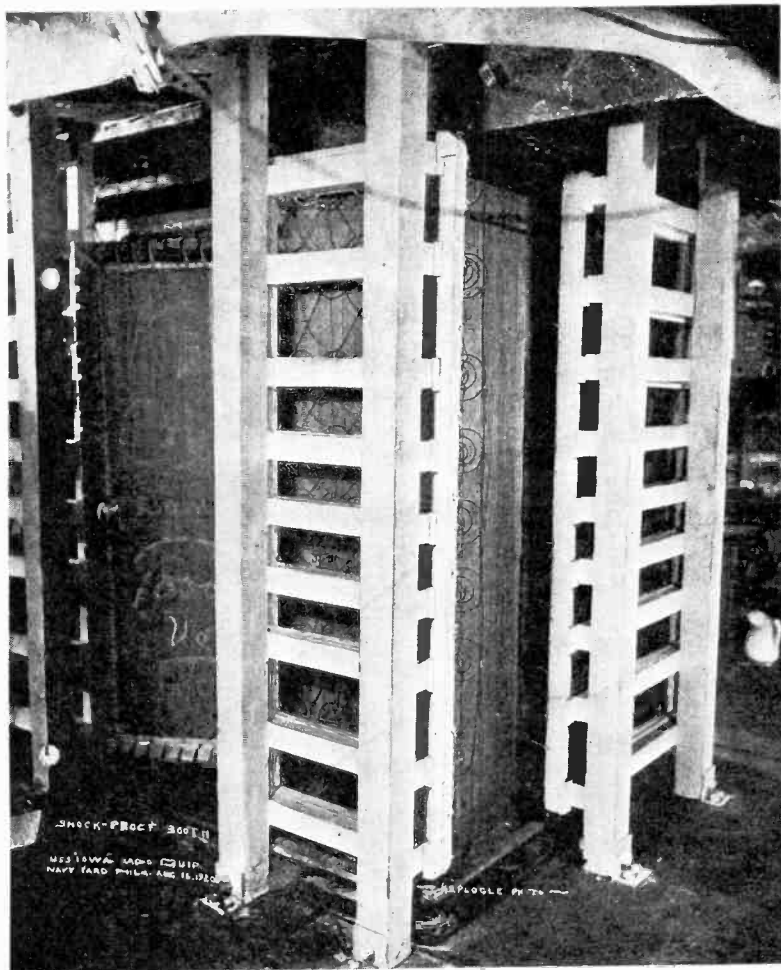

Fig. 10—View of the complete cabinet, installed on the U. S. S. Iowa, in which the receiving apparatus was placed.

A RADIO-CONTROLLED AUTOMOBILE

Figure 11 shows a view of a radio-controlled car together with the controlling mechanism installed on same. The principle used in controlling this car was dependent upon the length

of the dots and dashes used or the combination of these dots and dashes sent out by the transmitter. For instance, the letter R, dot-dash-dot, was assigned to the operation of starting the car in reverse, while A, dot-dash, would start it ahead. To stop the car and release all controls, a single dot was transmitted, which would release all the controls and shut off the driving motor current.

The car was thus in complete control at all times. The selection of any operation was accomplished within one second or less, and any operation could be stopped almost instantaneously.

The actual controlling mechanism consisted of 15 relays of the type used in telephone plants, mounted on a small framework such as shown in Figure 12. The wiring was tied together in cable fashion back of the frame and external connections were made by a center binding post at the top of the frame. Any type of radio receiver may be used with this unit provided it has sufficient variation in the plate current of the last tube to operate and release the sensitive relay. The "output" of the selector consists of 11 control wires, leading to the various pieces of apparatus to be controlled such as steering magnets, lights, etc. Each wire corresponds to a code letter. When a letter is received by the radio receiver it "sets up" the relays in such a combination as to connect the corresponding control wire to ground. The operating battery for the control magnets or lights being grounded on one side, this section supplies current over the control wire to the piece of apparatus selected, and it begins to operate.

Then when it is desired to stop the apparatus a single dot is transmitted. This releases all the relays and returns everything to normal, awaiting the next call. The selector relays remain operative, or rather, "locked," as long as any piece of apparatus is in use. This means that only one circuit may be used at once. Consequently the car could not be steered (for example) while it was in motion. To overcome this difficulty, a driving motor relay was built, which could operate in either of two directions, one of them sending the car forward and the other sending it backward. In either position a little latch would drop and hold the contacts in that position. There was a third operating magnet which was arranged to lift the latch and allow the relay to return to a normal position, stopping the motor. In that way it was pos-

X
9
7

sible to have the selector free for steering, blowing the horn, etc., while the car was running either way. A code letter for stopping would, when transmitted, ground the lead to the latch-lifting magnet and open the circuit.

Power to operate the relays was supplied from a 22½-volt radio "B" battery. Surprising as it may seem, one battery will furnish enough energy to operate the selector over 2000 calls. This is due to the fact that the relays are highly efficient, most

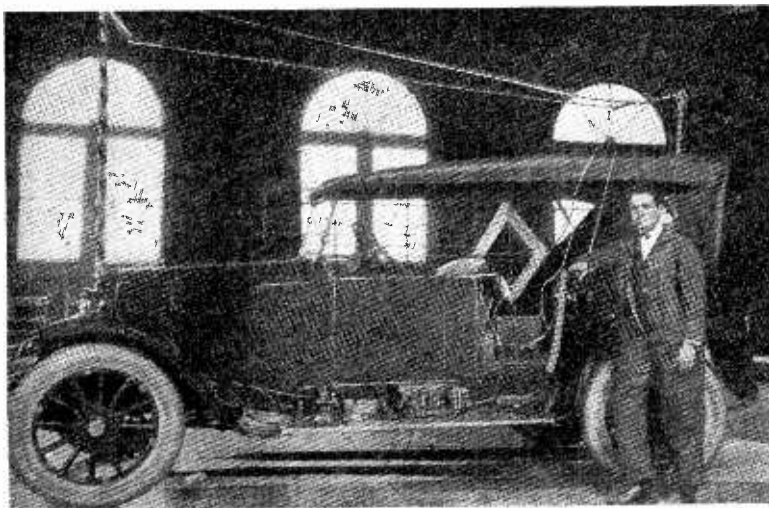

Fig. 11—The radio-controlled automobile equipped with the apparatus described

of them requiring only a few hundredths of an ampere to operate, and to the fact that the selector is not tied up while the driving motor is running.

Figure 13 shows details of the schematic wiring diagram. A relay is shown as a magnet with pivoted armatures at either end, each armature having one or two contacts associated with it. When current flows through the winding the magnet is energized and these armatures are drawn toward it, making those contacts which are shown open and breaking those shown closed. The relays designated CI and S are marked "SR" on the core. This means that they are built to operate quickly, but will not release until about one-third of a second after the current in the winding has been cut off. Most of the relays are supplied with "locking circuits." That is, when they are operated, by any means, they close another operating, or locking, circuit through one of

their own make contacts; they remain operated, or locked, after the original operating force is removed. The battery supply is shown as follows: To every point shown grounded is connected the positive side of the battery, which is grounded, and to every point where a battery and ground are shown is connected the negative side of the battery. This convention merely simplifies the diagram.

The relays A, B and C really do the selecting. It will be noticed that, starting at the right-hand armature of A, it is possible to follow eight different paths to control leads, depending upon the combination of relays operated or released. In

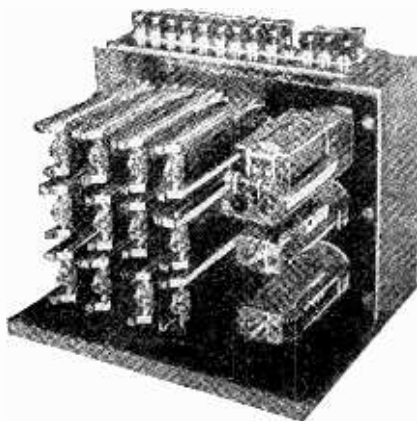

Fig. 12—The bank of relays used to control the different parts of the automobile

order to operate any desired combination of relays we arrange the code signal with the three impulses (dots and dashes) corresponding to the three relays, A, B, and C, in order. If we want A operated, B released and C operated, we send dash-dot-dash.

The relays 1, 2, 3, 1', 2' and 3' operate as follows: The beginning of the first pulse operates 1', the end of the first pulse 1, the beginning of the second pulse, 2', and so on. Each relay remains locked after it operates. Note that this action connects a lead from the right "make" contact of the relay S-1 to the windings of A during the first pulse, B during the second pulse, and C during the third. If a given pulse is a dash, the S-1 relay, with the S will have time to operate so as to place a ground on the lead mentioned above, so as to operate the corresponding A, B or C relay. This and a little study should make clear the process of selection. The CI relay, of the slow-release type, is energized

with each pulse, but does not have time to release between pulses. Its release after the signal is complete closes ground from its right armature and contact to the circuit, which has been selected. The R-N or "return to normal" relay operates when a pulse is received and the relays have been set up for a call long enough for the CI or "cut-in" relay to release. When R-N operates, it opens the circuit to ground which has been holding the selecting relays locked. The relays A, B, C and 1', 2', 3' in a

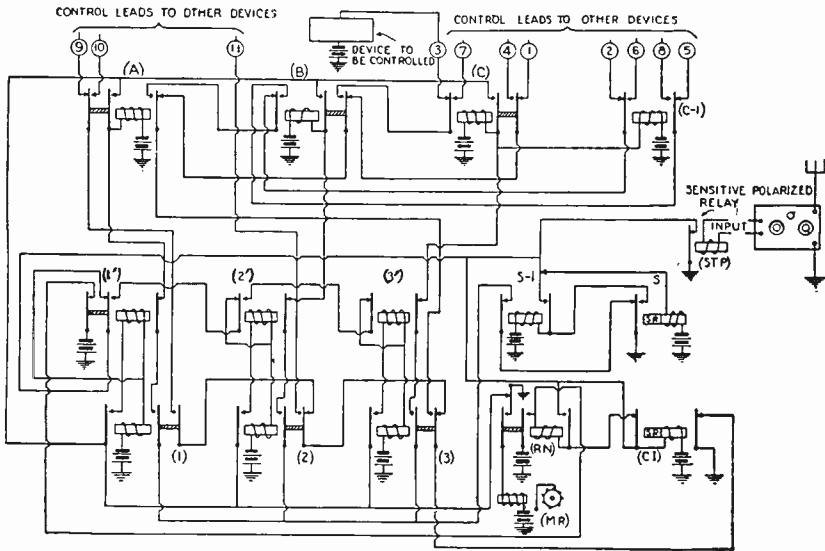

Fig. 13—The circuit diagram of the equipment used to operate the automobile

moment break contact on R-N. The STP relay is a sensitive polarized stepping relay, which operates from the radio receiver output. It furnishes ground pulses from its make contact to operate the numbered relays, the CI relay and so on.

Although the process of selecting an operation seems to be very complicated, the relays operate quickly and surely, if the dots and dashes are of the right length, however, if these dots and dashes are not of the right length and evenly spaced, the relays may fail to select the correct circuit. By adjusting the S and CI relays, the circuit may be adapted to high or lower speed accordingly. By connecting an electrical counting device, indicated by MR on the diagram, in this circuit, the number of calls handled by the selector is known at all times.

THE RADIO-CONTROLLED AIRPLANE

The question of making an airplane entirely automatic and radio-controlled, and to replace the skill of the pilot by mechanical devices, is one of the most difficult to solve. The piloting of an airplane may be learned in a few days. The necessary skill, however, is only acquired after many flights and it is a profession which calls mostly for the sporting qualities of an individual. The innumerable factors which must be contended with by the reflex actions of the pilot necessitates the use of such mechanism presenting extreme flexibilities in order to compare with the human control of an airplane which meet with so many varying conditions while in flight.

If it were possible to connect the airplane with a controlling station by means of a cable, the problem would be comparatively simple. Such a solution was employed during the year 1921, where an electrically controlled airplane flew, followed by another one in which were the pilot and the controlling operator, the two planes being connected with a cable. This, however, only displaced the question, since it was necessary to have a pilot in the second plane. Furthermore, this method is not very practical, nor flexible and presents some danger for the controlling airplane. The only practical means of connection to be employed between the automatic airplane and the ground is, therefore, radio. However, on account of the small amount of energy which it is possible to transmit to the craft, it is necessary to use sensitive devices with receiving apparatus, as well as selective circuits to eliminate the possibility of the airplane being accidentally controlled by signals from another source, or atmospheric disturbances.

The first big problem to be solved in controlling an airplane by radio was that of the automatic stabilization of the craft. Since the beginning of aviation, many devices have been proposed to diminish the risk of human control. Among these may be mentioned the Aero-Dynamic Rudder, the Sperry Gyroscopic Stabilizer, the Aveline Mercury Stabilizer, and many others, but none of them gave all the desired results, and for this reason were abandoned.

The problem of automatic stabilization, in fact, is very complex for an airplane in flight tends to take three different rotary motions around three rectangular axes, and three motions of translation along these axes. It is necessary, when the airplane

has to fly along a given line, to follow within five or six degrees of possible variation. For this reason it would be necessary to install five different stabilizers on account of the difficulty which is found in designing mechanism having more than one degree of variation. However, it was found possible to limit to three the number of necessary stabilizers. An airplane properly balanced tends, as a boat, to come back to its position of equilibrium if it does not list too far on either side, and thanks to this property, it was found possible to absolutely control and compensate for the variations encountered in flight. To obtain

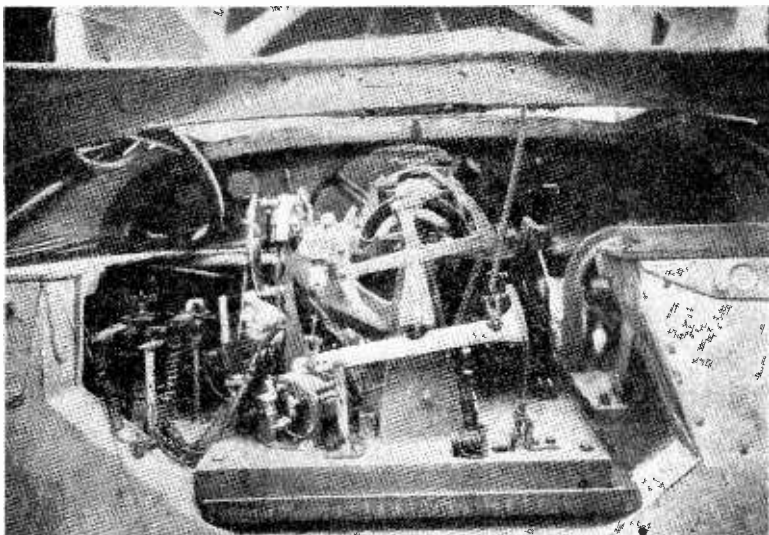

Fig. 14—The gyroscopic stabilizing apparatus shown here takes the place of a pilot and automatically keeps the plane in the proper position while in flight.

the absolute control of the craft the stabilizers must be able to operate some compensating forces capable of bringing it back into the correct position and stop these forces before it has reached it in order to prevent the undesirable oscillating motion. Six organs must, in principle, constitute a stabilizer for automatic airplanes:

First, a fixed point connected to the airplane itself.

Second, another point fixed to a given unvariable plane, which may be at a given angle, so as to stabilize the plane in relation to the air currents.

Third, several controlled motors acting upon the various organs of the control.

Fourth, an inertia compensator preventing the reactions of the fixed point which must be unvariable. It is well known that a pendulum, moved in space, for instance, may be subject to acceleration when changing its period and not indicate the vertical line. This is why its use, as well as that of similar devices, is prohibited on board an airplane.

Fifth, a controlling organ connecting the fixed point to the movable one so that the action of stabilization may stop before the normal position is again reached.

Sixth, a controlling device to prevent the reaction of the air upon the controlling organ to impress the controlling apparatus.

Of course, these six controls must function perfectly and independently, no matter how great the disturbances impressed upon the airplane. This gives an idea of how complicated the first condition of automatic control is, for in practice every one of the organs must be carefully adjusted, and this requires a great amount of work.

The type of automatic stabilizer most commonly used in airplane radio control is shown in Figure 14. It is a form of the Sperry Gyroscope modified so as to make it fit for this particular purpose. It consists of a disc of small weight but turning at a very rapid speed (15,000 to 18,000 revolutions); it has considerable inertia and among other properties tends to remain always in its rotating plane. One of the most detrimental properties of the gyroscope when used in aviation control is the tendency which it has to move perpendicularly to its plane of rotation when it is displaced from this plane. Thus, the gyroscopic effect must be compensated for by another gyroscope rotating in the opposite direction and playing the role of the fourth organ mentioned previously, the inertia compensator. For properly balancing and distantly controlling an airplane, it must be equipped with two gyroscopes coupled together and rotating in opposite directions so as to control the upward and downward flights, another one for the lateral equilibrium and a third to control the direction. These systems of gyroscopes are equipped with a fixed sector upon which a brush contact is made and moves when the airplane is unbalanced in one plane or the other. These establish electric contacts which by means of electric motors, such as shown in Figure 15, control the action of the rudder and wings.

The flexibility of this type of control is such that the airplane thus controlled may fly in strong winds and always come

back to the normal position when it is deviated from one plane or the other. In order to start the airplane from the ground and control its flight it is necessary to suppress the action of the automatic stabilizers. It is at this point that radio control is employed to change the ratio of the gears controlling the various stabilizers. This is accomplished by a mechanism somewhat similar to the transmission of an automobile. For quick action the movement of the brushes sliding upon the sectors may be stopped and the former kept in a fixed position so as to make the airplane go up or down or turn quickly, the speed being regulated by the transmission arrangement method above. All

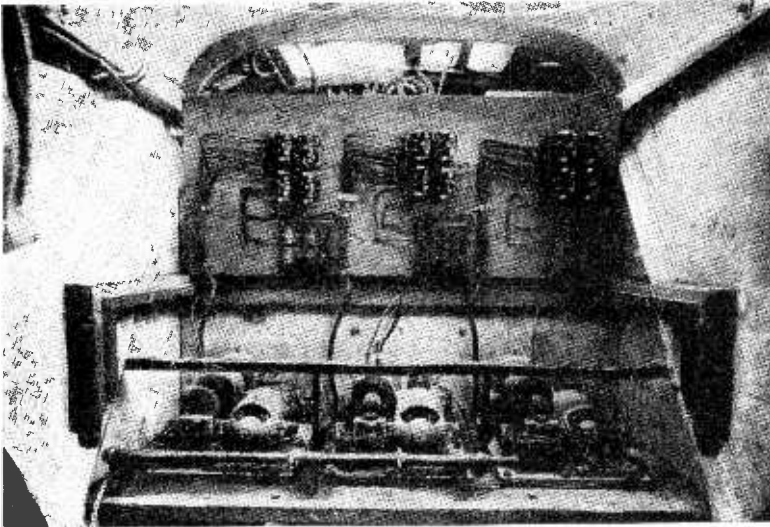

Fig. 15—The electric motors operating the various organs of the plane

these controls are assembled on a panel and are operated by a series of relays connected to the radio receiver. Once a control has been set in a certain position, it remains so until it is opened by radio signals, thus if the airplane is put in such a position, so as to fly around, it will do so until the proper control is operated to change its course.

In this system of radio control, a special modulated wave was employed with a very low-frequency amplifier which was designed especially to amplify the sub-audible modulation permitting the controls to be operated only at the will of the operator. By means of the special chopping system this sub-audible modulation may be interrupted to form signals which operate

the distributor and selector systems connected after the amplifying device. The distributor consists of a cylinder upon which are cut slots corresponding to the various controls; a series of blades may fall in each one of these slots as the cylinder is rotated at a fraction of a turn at a time. This establishes contact with a local control circuit through a relay which delays the action; hence from one-tenth of a second to one second elapses before the control is operated.

The controls on board the airplane not only operate the various controls of the engine but also move the brushes on the gyroscopic system so as to cause the airplane to respond to the commands of the operator, who is able to direct it and vary the speed according to the necessity of flying conditions. The efficiency and flexibility of this radio-control system was proven by a number of tests. Five tests had to be passed, consisting of flights of 15 minutes at various altitudes, several turns to the right and left, landings and flights at 1500 ft. and 3000 ft. In the last test the aircraft had to effect a spiral landing of 1000 ft. in diameter from an altitude of 3000 ft. which it accomplished perfectly. These tests present considerable interest, for they show that the automatic radio-controlled airplane is practical and may be developed to such a degree of perfection that it will be possible in the near future to use it for commercial purposes. It could be sent up, directed toward a certain city and taken down by means of another radio station, installed on the landing field, which would take over the control of the plane upon its arrival within the radius of the controlling station, the plane flying by itself between the two aerodromes.

All the apparatus previously described are applicable in controlling the largest sizes of aircraft, thus the pilot, not having to worry about the control of the airplane, will be able to keep in touch with the ground and other aircraft by means of radio and to closely follow his route by checking its position on the map. This system will also permit the use of pilotless airplanes for the transportation of cargo and meteorological observations at high altitudes. In this case recording apparatus equipped with electric contacts would control various mechanisms which it is necessary to operate when reaching high altitudes. This control might also be operated by means of clocks since the speed of the airplane is known and also the angle at which it goes up. These methods of control are only practical within a short radius,

or for a limited number of operations; as soon as the airplane has to fly over great distances and through a great many varying conditions, the controls must be more flexible and radio is then employed to operate, on board, the controlling devices.

TEST QUESTIONS

Number your answers 47 and add your **Student Number**.

Never hold up one set of lesson answers until you have another set ready to send in. Send each lesson in by itself before you start on the next lesson.

In that way we will be able to work together much more closely, you'll get more out of your course, and better lesson service.

1. Who invented the "electric dog?"
2. How large a potential is necessary for the satisfactory action of the potassium cell?
3. Draw a diagram illustrating the fundamental principle upon which the Hanson system of control operates.
4. How may the frequencies be obtained in the Hanson control system?
5. What kind of an antenna was used in the U. S. Navy tests to overcome static?
6. What kind of a receiver was used in the Navy tests of radio control?
7. Where was the receiver placed in the radio-controlled battleship?
8. What was the speed of the ships used in testing the radio-controlled battleship?
9. How many relays were used in the radio-controlled auto described in this text-book?
10. Why is it necessary for the receiver used on a radio-controlled airplane to be very selective?

