

NATIONAL RADIO INSTITUTE

Complete Course in
PRACTICAL RADIO



TR

Radio-Trician

(REG. U. S. PAT. OFF.)

Lesson Text No. 26

**SUPER-HETERODYNE
TROUBLES AND
THEIR REMEDIES**

Originators of Radio Home Study Courses
... Established 1914 ...
Washington, D. C.

CONFIDENCE

A Personal Message from J. E. Smith

There is considerable value in one's intentions and confidence. One should undertake study, expecting to concentrate upon it. Likewise, one should expect to remember what has interest and value in his study.

Copyright 1929, 1930
by
NATIONAL RADIO INSTITUTE
Washington, D. C.

Radio-Trician's

(REG. U. S. PAT. OFF.)

Complete Course in Practical Radio

NATIONAL RADIO INSTITUTE,

WASHINGTON, D. C.

SUPER-HETERODYNE SUGGESTIONS

Some Practical Ideas for Improving the Reception Obtainable With This Popular Circuit

The Super-Heterodyne circuit is much misunderstood and consequently leads to too great expectations. The amplification produced by an eight-tube set can be but little greater than that given by three stages of tuned radio-frequency detector and two stages of audio, such as might be secured from a six-tube neutrodyne.

The first two tubes of a super, the oscillator and first detector, act merely as frequency converters, changing the incoming frequency to that to which the intermediate frequency amplifier

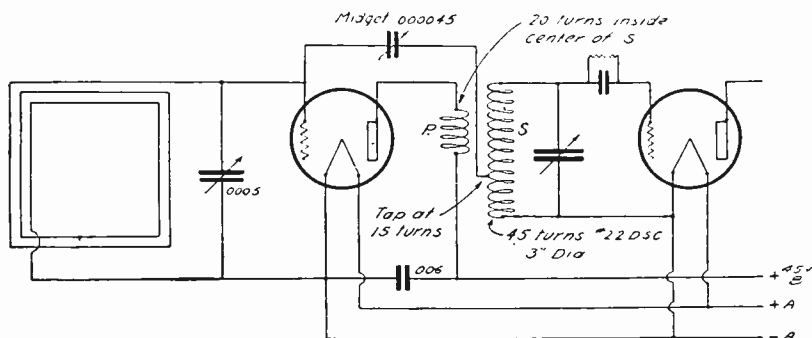

Fig. 1—Diagram illustrating method of adding one stage of tuned radio-frequency between the loop and the first tube.
(Pick-up coil not shown in this diagram.)

is tuned, only a limited amount of amplification being supplied by the first detector. The Super-Heterodyne differs from other radio-frequency circuits in that it tunes the incoming wave to the intermediate R.F. stages, whereas the others tune each R.F. stage to the incoming wave.

Therefore, "why the super-het?" The answer is found in the fact that the lower the frequency (the higher the wavelength) at which a radio-frequency amplifier is used, the greater its amplification. By amplifying wave-lengths between 1,000 and 10,000 meters (300 Kcs. and 30 Kcs.) the Super gives greater

amplification than another circuit amplifying between 200 and 600 meters (1500 Kcs. and 500 Kcs.). It is also more selective, more stable, and easier to operate. It makes better use of the small amount of energy supplied by a loop than other sets can do with the larger amount of energy supplied by an outside aerial.

Several improvements can be made in the Super-Heterodyne sets as ordinarily constructed. The first is the use of a larger loop to collect more energy. A loop having 3 to 5 feet to a side is none too large. It should never be less than 2 feet to a side if good results are to be secured.

Another practical improvement is the reduction of the B battery voltage to the R.F. amplifiers. The heavy current that these tubes take, if the set is operated with a potentiometer giving a positive bias to the grids, can be greatly reduced by cutting the B potential to 45 or even 22 volts.

An expensive but useful addition is a shield that completely encloses the set. This prevents, if properly installed, any pick-up by the wiring of the set itself and in that way often provides a worthwhile gain in selectivity. The shield is equivalent to a metal box that completely includes the apparatus and should be installed when the set is built.

An outdoor antenna is sometimes used. If the set is shielded it is possible to get a degree of selectivity entirely unexpected. Loose coupling should be used with the coils that tune the antenna and secondary adjusted permanently in one angular relation that does not give maximum signal strength but good signal strength with satisfying selectivity. The secondary coil, which replaces the loop, is outside the metal shield and, although it will pick up directly, its main pick-up from the antenna coupling coil will result in soul-satisfying distance.

The addition of a stage of tuned R.F. amplification ahead of the set itself is also practicable. It is particularly useful in the event of a bad location where a loop must be used or where the size of the loop is limited and a definitely better pick-up than now possible would be of great value. The details of such a unit are shown in Figure 1. This adds a third tuning control to the set, but it prevents the set from radiating, which too many Super-Heterodynes do—very effectively.

Despite what has been said from time to time, the addition of a stage of intermediate amplification, making four instead of three as in Fig. 2, is useful if done properly. Two of the R.F. stages are controlled by one potentiometer and two by another

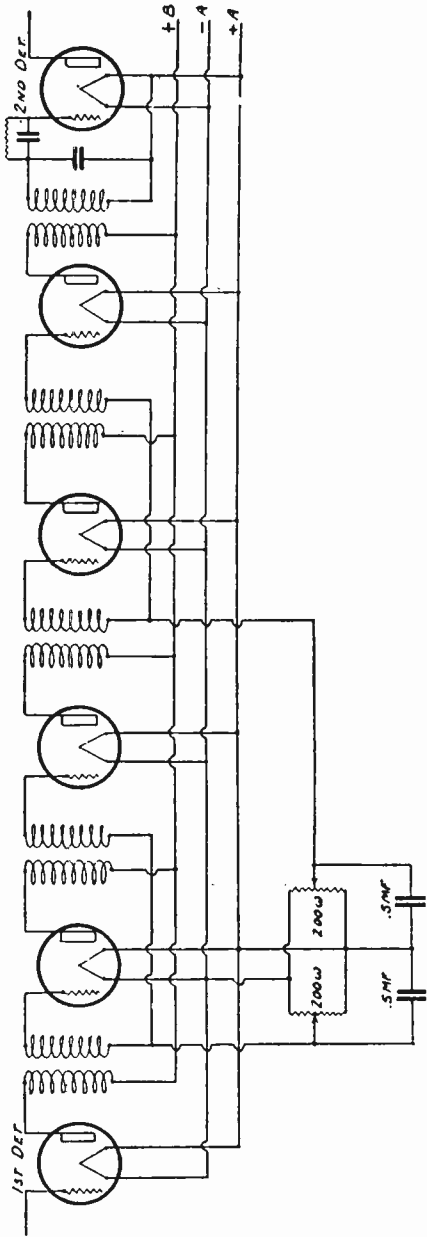

Fig. 2—Diagram showing method of controlling four intermediate stages.

This is apparently adding one control, but in actual operation the one potentiometer is set for a position close to oscillation and the other will be found to control all four stages. Only one of the potentiometers is put on the panel while the other is mounted with the other parts and adjusted by test to the proper point. Thereafter the panel potentiometer will be found very effective for controlling the intermediate frequency oscillating point to a nicety.

The addition of regeneration to the set is an easily accomplished thing that is included in a number of Super diagrams. The circuit of the Super-Heterodyne provides a certain amount of feedback from the loop circuit in the first detector by the use of a .00005 mfd. variable condenser which serves as a feedback control while tapping the loop, which provides the necessary inductive coupling to the grid circuit.

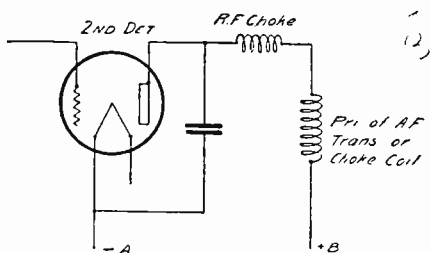

Fig. 3—Use of Radio-frequency Choke in Second Detector.

A word here about one thing may save someone some trouble. When using a circuit, where the first I. F. T. is an untuned one, this first IFT cannot be tuned if regeneration through the loop tap is desired. If a tuned transformer becomes the first one, the capacity used to tune the primary of this acts as a by-pass of that energy that should be fed back and no regeneration results. One fan, who preferred his tuned I. F. T. to come first, tried this and discovered that he had lost the sensitivity due to regeneration. The only remedy of this condition is a R.F. choke in the lead from the plate of the first detector to the plate connection of the first amplifier transformer. This should consist of 350 turns lumped on a small spool.

The most frequent fault in Super construction is the use of incorrect by-pass condensers. A Super handles two kinds of radio-frequency current: that having the frequency of the incoming signal and the oscillator, and that having the much lower frequency of the intermediate radio-frequency amplifier. The

first require relatively low capacity R.F. by-pass condensers and the second relatively large. It is not unusual to see an .005 mfd. fixed condenser across the potentiometer of a 30 Kc. Super. This capacity is supposed to by-pass the R.F. around a 400 ohm potentiometer when its own reactance at 30 Kc. is 1,061 ohms. A .5 mfd. condenser having a reactance of about 10.6 ohms at 30 Kc. would be far more effective. Remember that reactance varies inversely as the frequency and also inversely as the capacity.

A peculiar by-pass condition is met in the second detector. To use a capacity much greater than .002 mfd. would result in rather bad distortion. This is particularly true where high primary impedance audio transformers are used. Yet .002 is inadequate because its reactance is in the order of 2,654 ohms at 30

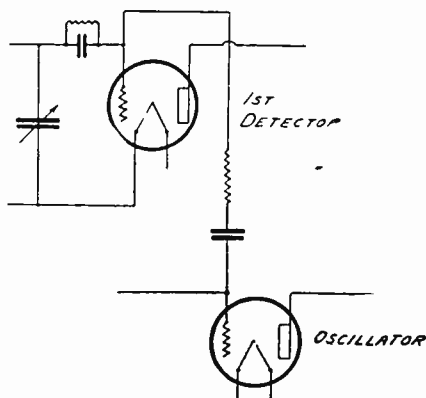

Fig. 4—Coupling Oscillator and First Detector by means of Resistance.

Kc., that being our illustrative frequency which puts a large part of the intermediate R.F. into the audio amplifier, and often results in instability because there can be feed-back from the loud-speaker to the first detector or the antenna circuit. Also, it sometimes happens that this R.F. causes howling in the audio amplifier. The remedy is a choke inserted as in Fig. 3. This R.F. choke can well consist of the secondary of one of the intermediate R.F. transformers with the primary left free. By purchasing an old I. F. T. whose resonant point is at a lower frequency than that of your intermediate R.F. you will be safe. Actually, every manufacturer should include a R.F. choke for this purpose in his Super kit. The choke should be a closed iron-core and it could be made quite small. A R.F. choke in the position as shown in Fig. 3 must not be too large or it will cause distortion by reducing the

7
3

amount of the higher audio frequencies that reach that audio amplifier. Too low an intermediate R.F. would require too large a choke, so the only remedy is to choose the I. R. F. at a fair compromise. Between 3,000 and 6,000 meters is excellent for the purpose. On an unshielded Super-Heterodyne the use of a choke as in Fig. 3 is an absolute necessity for perfect performance.

The proper use and isolation of the energy of the oscillator of a Super-Heterodyne is important. The detector tube, upon which is impressed the oscillator and signal energy, operates best when the signal energy and oscillator energy inputs are the same. This points to the need of an adjustment that should be made for each signal, but this is not practically necessary. The man searching for supreme DX should have such an adjustment, but the man desiring a good and sensitive all around

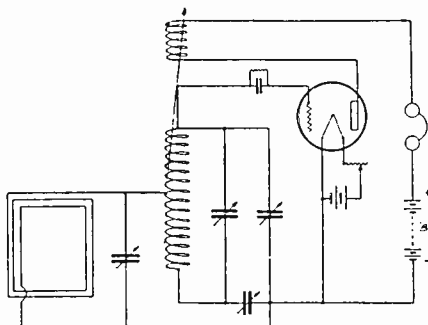

Fig. 5—Super-Antodyne Detector Oscillator.

receiver does not want a multiplicity of adjustments. However, such an adjustment, if provided, can be left fixed for the more normal receptions while always ready for the sympathetic touch of the searcher for distance.

Before going into the arrangement of the oscillator, the more ordinary and familiar methods of limiting the detector's pick-up from the oscillator will be of interest. There is the method of coupling the grid of the oscillator to the grid of the detector through a resistance and a capacity. This is shown in Fig. 4 and is used in some types of Super sets. There is the usual idea of a two to five turn pick-up coil run from the detector to the oscillator or vice versa. In some sets there is an oscillator-coupler with a rotating coil for pick-up containing anywhere from 10 to 40 turns. Although an adjustment of the coupling of the pick-up to the oscillator coils is possible, it is often true, due to

jamming of parts or else the size of the pick-up coil, that anywhere between the limits of rotation of the coil pick-up is much the same and the adjustment proves useless. This had led many to the false conclusion that an adjustable pick-up is of no value although a correct trial would convince them otherwise.

Then there is the arrangement of Pressley's used by McMurdo Silver in the Super-Autodyne in which the detector and oscillator become one tube. This is an arrangement that can be made every bit as good as the separate frequency-converter arrangement if the tickler is arranged to be controllable from the panel so that the degree of oscillation can be adjusted to an exactness. It has seemed odd to me that such an arrangement has not been suggested before, for in practice, to the man that likes to push his set to its limit, it works out very well. The Super-Autodyne converter is shown in Fig. 5.

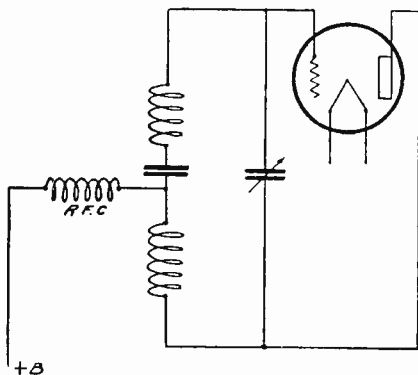

Fig. 6—Diagram showing method of localizing Oscillator Current.

If the isolation of the oscillation energy is provided for, it is not difficult to arrange the proper use of it for beat purposes. The trouble in most cases is in not properly isolating the oscillator current within the oscillator or circuits where no harm can result from its presence. This isolation can be accomplished fairly well by simple means. It is necessary to see that the detector circuits are well separated from the oscillator and associated apparatus. It is a good idea to build the oscillator coil in some form that has a limited field. This can be done by making the oscillator coil very small in diameter, 2 inches or less, wound with fine wire, or by using a special form of coil such as the Toroid, the Binocular or the D coil.

For instance, the ordinary oscillator circuit using a two section coil would, on a 2 inch diameter, require a coil of 70

turns of No. 30 d. s. c. wire, 35 turns in each section, wound in the same direction, and to be tuned with a .0005 mfd. variable condenser.

The losses that occur in an oscillator are unimportant since it always has many times the power needed. To further keep the oscillator energy within reason no more than $22\frac{1}{2}$ volts should be used as B battery. It has been known for a loop of a Super to pick up energy directly from the oscillator, because the field of the loop and oscillator coils were so large that no other means of pick-up was necessary, even this being too much. J. L. MacLaughlin in the one-control Super keeps energy from the oscillator circuit from getting into the B battery by means of a choke coil as illustrated in Fig. 6. This should not be necessary where a sufficiently large B battery by-pass condenser is used, .1 mfd. or more.

Probably as good an arrangement as possible is to remove the oscillator tube and components to the end of the set farthest from the first detector and try out the set without any pick-up direct and intentional. If the set works well without an apparent pick-up, then the pick-up is from the wiring and other parasitic feeders. If there is no pick-up, arrange the pick-up coil with a variable shunt resistance according to Fig. 7, the pick-up coil being from 3 to 6 turns, 3 generally being enough. If the variable resistance has a good range, the adjustment of pick-up provided will take care of any condition of incoming signal-strength. The pick-up coil should have about 6 to 9 turns when the variable shunt resistance is used since the pick-up can be reduced to any desired strength. A variable grid-leak with a range of $\frac{1}{2}$ to 5 or 6 megohms would be excellent for use in place of the resistance R in the coupling method as used in some types of Super sets as it would allow a very nice control of the pick-up energy. In this latter case some capacity effect would likely result but it can be partly eliminated by carefully mounting the variable resistance with a fairly long control shaft.

The best method of protecting the set from any pick-up from the oscillator, other than that intended, is to shield the oscillator circuit completely. As was said before, losses in the oscillator are of not much importance, so it can be crowded to get compactness.

Air-core intermediate R.F. transformers are not always desirable for Super-Heterodyne use. They are too sharply tuned, in the main, and when they prove to be not so sharply tuned

they often prove also to be ineffective. Tubes whose capacity vary, differences in wiring capacity from stage to stage, and small similarities can affect the amplification of a sharply tuned transformer. The iron-core transformer is not sharply tuned and is justly the favorite at present. In any case the transformer should be inclosed within a shield unless it has an open iron magnetic circuit. The transformer with a good shield will not interact with its teammates, an important virtue. A closed iron core often makes in effect as good a shield as an inclosing can.

Sometimes exceptional pick-up results with a Super that is credited to the circuit rather than to outside influences. Particularly is this true where unusual results are secured with a

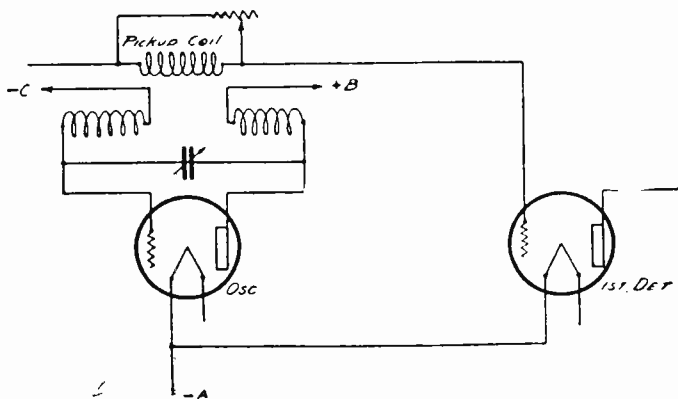

Fig. 7.—Variable Resistance Pick-up Control.

very small loop and a normal circuit. In one case, the pick-up of the wiring in a house was the entire foundation of his (the owner's) success with a Super. He could hear anything worth hearing until the place was remodeled and the wiring run in grounded conduit. A similar case will be found with smaller set owners who are unable to surpass a light-socket antenna plug with a good outdoor antenna.

Another peculiar situation due to house-wiring occurred with one Super owner who was getting excessive interference from a local station. It was another case of open wiring. The house-wiring was practically on the wave-length of the local station and was thus full of quite a bit of energy from it. A strong signal field existed about this set so that in spite of everything that could be easily done, it was impossible to get away from interference from the local jazz generator. The owner

was disgusted because he had built what was supposed to be a highly selective set and it had proved otherwise. The problem was solved by the use of three or four high capacity fixed condensers connected across the A.C. wiring in several widely spaced positions. Then the local station's strength dropped, insofar as excess was concerned, to a reasonable point and the set was able to tune it out.

Since the above case points to how easy it is to misjudge a set or circuit there is one other thing to be said in relation. That is, comparisons between circuits and sets are seldom made fairly. A particular instance was a man who built a conventional "Super" set that performed very nicely in a good location and of which he was very proud. Later he built another arrangement with a little different kind of oscillator circuit and a new "dyne" name. This he praised very highly as being much better than his original set. He was told that a tremendous difference was impossible with the same parts and but a rearrangement of the oscillator connections. Then we looked things over. The whole reason for the better performance lay in a loop whose

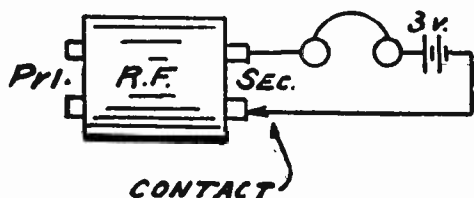

Fig. 8—Testing Secondary of I. F. Transformers; Primary tested in the same manner.

dimensions were nearly 6x6 feet in place of the 3½x3½ feet previously used.

Now that we have made several valuable suggestions which should be given careful consideration in the design and construction of the Super-Heterodyne receiver, it seems fitting to turn our attention to the matter of testing out the set and defects that may develop in its building.

We will first give a list of the ordinary troubles that may develop in the receiver and then follow it by a more detailed discussion of the individual tests for some of these more important troubles.

The following points should be carefully checked before proceeding with the operation of the receiver.

Test all of the batteries, or power units.

Clean and test all battery connections.

Make sure that the tubes are making good contact in the sockets and check all battery polarities for reversals.

Make sure that the leads to the condensers are in good condition.

Also check up on your loop aerial and make sure that there is not an open or short circuit in your aerial circuit.

Plugs not making good contact with the jack.

Variable condenser shorted.

Defective or burned out transformer or poor connections to same.

Defective Vacuum Tubes, or Rectifier Tube.

Potentiometer defective.

Fixed Condensers shorted.

Defective grid leak or condenser.

Grid condenser of too high a capacity or grid leak of the wrong value.

Parts of the apparatus touching the panel shield.

The power supply voltage too high.

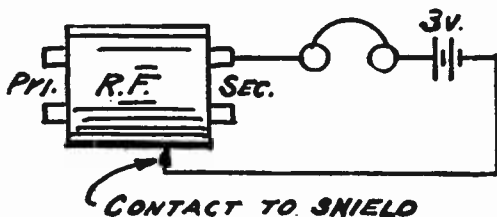

Fig. 1.—Testing Secondary for Grounds; Test Primary in same manner.

ADJUSTING YOUR SUPER-HETERODYNE

How to Find and Remedy Possible Trouble in the Home-made Instrument

After you have carefully wired up your Super-Het, as per specifications, you may find that it will not “perk” at first. Such troubles can usually be remedied if you know what to look for.

First be sure that your sockets and intermediate frequency transformers are all right. Test out each instrument for shorts, open circuits, or grounds with a pair of phones and battery as in Figs. 8 or 9. The transformers should give a loud and distinct click when the circuit is made and broken through both the primary and secondary circuits. If shielded, test for grounds to the shield.

See that the condenser terminals make good contact. A rubbing contact, if dirty, may not be good. In soldering, be sure that the wire isn't held mechanically but makes an excellent contact as well. Stray noises, very difficult to locate, frequently come from this source, especially if in the detector or oscillator circuits. Polish up all socket contacts with fine sandpaper. Rub the tube terminals on a clean piece of fine sandpaper. The lead oxide film isn't very deep and is easily removed. The thoroughness with which the various instruments are tested may mean the difference between success and failure.

Now let us suppose that you have assembled the set, and are ready for a try out. It has been found that a meter in the positive B supply lead to all the tubes is one of the most helpful things for testing any set. The meter need not be calibrated, but may be a high voltage voltmeter minus the series resistance, as only comparative readings need be made.

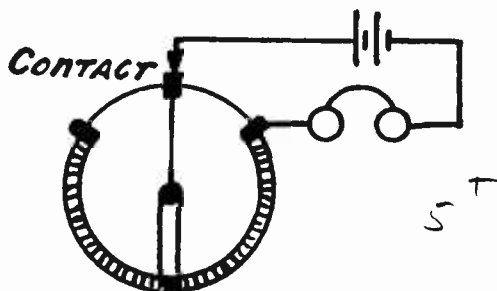

Fig. 10—Diagram illustrating the method of testing a Potentiometer or Rheostat.

The first thing to test is whether the filament circuit is right. Place one tube in a socket, and see if it lights. If so, try this tube in each of the other sockets, then disconnect the "A" battery.

Next connect the "B" battery or eliminator, without the meter for the moment, and short the filament leads momentarily by inserting a screw-driver between the socket contacts. If a large or unusual spark is produced, trace out the trouble. Make contact for an instant only or the batteries will be run down quickly. If the proper size voltmeter is available, it would be better to use it. If these circuits test all right, place tubes in the sockets, leaving out the audio-frequency ones for the time being.

Now plug the head-set in the detector circuit, and connect the meter in the "B" supply lead to the set. Take readings for each tube, and if there is one that seems to give unusual values,

discard that one for the time being. The tubes should all be tested in the same socket, as the position in the circuit will give varying space currents.

Test the potentiometer, if one is used, by turning the arm until a click or hiss is heard in the phones, and noting the action of the meter as the tubes go in and out of oscillation, for future reference. If no click or meter kick is observed, check the R.F. wiring, and if OK check the contacts on the potentiometer. There should be a circuit between its three posts regardless where the arm is placed. This is tested out by the means of battery and phones, Fig. 10. A grating noise as the potentiometer arm is turned indicates poor contacts on the wire, which should be cleaned. If the R. F. tubes are oscillating, touching and removing the finger from the grid terminal will each give a distinctive click, also the meter will give an upward kick when the oscillations are stopped.

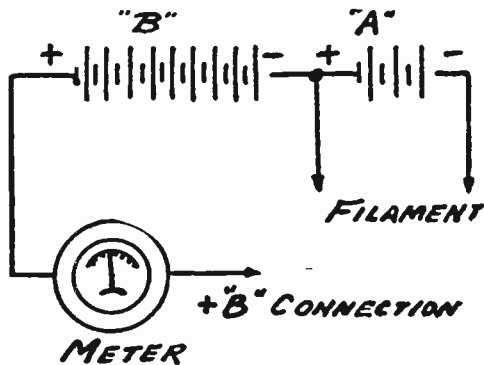

Fig. 10-A—Diagram illustrating method of connecting a Meter in the Battery Circuits.

The next circuit to test is that of the oscillator. If the grid of the oscillator is touched, a distinct click should be heard, and the meter should act in the same way as with the R.F. tubes, when oscillating. If the condenser is varied, a number of whistles should also be heard as it is turned through its various values.

The commonest faults of the oscillator are: too few turns on the plate feed-back (follow directions carefully); reversed plate leads; shorted or open coils, or poor contacts; or poor by-pass condensers. With an open plate coil, no space current will be shown on the meter. Lack of oscillations is shown by little or no change in the meter when the grid of the tube is touched. The filament adjustment, while not critical, must be above a

certain value for oscillations to take place. I have found that nine-tenths of the troubles in a Super-Het occur in the wiring of the oscillator circuit.

Now if the oscillator and R.F. tubes are working properly, tune in signals, and try out the tubes in various positions. Some tubes are good R.F. amplifiers, some good A.F. amplifiers, some good detectors, and some are distinctly no good.

Don't overlook your grid leak or condenser or any by-pass condenser. They may be way off capacity, shorted or otherwise defective.

Cut out the by-pass condensers and then connect them one by one until the trouble is found. The only test for these condensers is a comparative one made by listening to the strength of signals. Any decrease in signals will show a defective condenser, wrong capacity or incorrect position. Your meter will generally show up a defective leak, especially if its value is low, for then a positive potential is put on the grid of the detector tubes, and an abnormal plate (space) current results. A little testing will show just what to expect. A reversed "C" battery will also cause a tube to show an excessive plate circuit.

The actual tuning in is greatly simplified by the use of a meter. By noting the action of the meters as the loop (or secondary) and oscillator condensers are varied, the resonance point may be determined. The meter gives a distinct dip as resonance is passed through, which may be easily recognized after a little practice. The relative dip of the meter will also indicate, more or less, the strength of oscillations at that particular setting. A small change generally shows weak oscillations. With a little observation, and general knowledge of the tubes under varying conditions, it should not be difficult to correct and adjust the faults that usually occur.

As a summary the following is given:

No plate current—

- (1) Defective tubes.
- (2) Open plate circuit—
 - (a) Poor tube contact.
 - (b) Opened transformer.
 - (c) Defective wiring.

Abnormal plate current—

- (1) Positive potential on grid—
 - (a) "C" battery polarity reversed.
 - (b) Detector grid leak too low.

principle. If you are using a detector oscillating at twice the working wave-length so that its second harmonic is used to make the intermediate frequency, which gives you trouble, use a non-oscillating detector plus a **separate** oscillator. It may take several long months to make a second-harmonic Super work, and it always operates with more distortion than a separate oscillator would cause.

Next is the matter of reflexing. The plain Super-Heterodyne is hard enough to put into operation. Why add a hundred per cent more trouble at the start by trying to reflex any of the tubes? Reflex sets are OK when they work, but no two of them work alike. It takes hours and hours of tinkering to do any kind of a reflex job. All manner of reversing of connections and substitution of various by-pass capacities are necessary. When the tubes are finally tied down to the point at which oscillation ceases, nine times out of ten distortion occurs somewhere and we are a lot worse off than we would be if we had forgotten the reflexing and used an additional tube.

Getting Started

Assume that your Super is not working at all. It has been assembled according to blue prints, all connections are soldered and are actually making contact, the tubes have been tested and found to be OK, the "B" batteries are OK with other tests already given and still the set will not make any music.

In Fig. 11 there is shown a standard Super-Heterodyne circuit. If yours differs radically from this one be certain that there is some excuse for the difference.

The Super can be divided into five component parts, all of which must operate satisfactorily alone before the Super, as a whole, can be expected to function. There is No. 1 an oscillator or tuner, No. 2 a 1st detector, No. 3 an intermediate frequency amplifier, No. 4 a second detector, and No. 5 an A. F. amplifier in every standard Super-Heterodyne. Each of these can be tested separately and if there is any trouble it can be readily located. It would be wonderful if this point could be driven home. No matter what affects a set the thing can be found more easily by going after one thing at a time. This goes for transmitters also. Don't tear the receiver down because the tube gets hot, sit down and think it over, then change **one** thing at a time and watch what happens.

The Oscillator

The coils A and B of the oscillator inductance (Fig. 13) should be wound in the same direction, and the grid of the oscillator tube should be connected to the outside end of coil A and the plate to the outside end of coil B. If these connections are reversed, the oscillator will not operate and the whole set will be dead. The oscillator tuning condenser C2 is connected across the grid and plate of the oscillator tube. The rotary plates of this condenser must be connected to the plate, otherwise the hand capacity effect will be bad when varying this condenser. The by-pass condenser across the inside ends of coils A and B should have a capacity not less than .005 mfd., and should be mounted as near the coil as possible so that the leads from the condenser to the coil will be short. Coil C is the pick-up coil, which is coupled to the oscillator coils. If no means are provided for varying the coupling between coils B and C, coil C should consist of only one or two turns wound directly over coil B (Fig. 13).

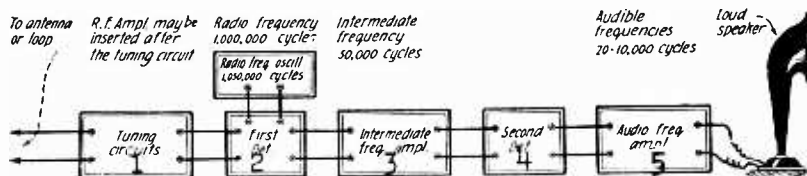

Fig. 12—This illustrates the five essential parts of a Super-Heterodyne receiver:

Parts 1 and 2 act as a frequency converter, making the short-wave signal into a long-wave signal. The intermediate frequency (or long wave) amplifier is then able to handle this signal.

- 3—The intermediate frequency (also called super-sonic or long wave) amplifier which amplifies the long-wave signal passed to it by 1 and 2.
- 4—The second detector that converts the long-wave signal into A. F. passing it on to No. 5. No. 5 amplifies the audio frequency and feeds it into the head-set or loud-speaker.

The only possible sources of trouble in the oscillator circuit are (1) a short circuited or open circuited by-pass condenser. If there is a short on the by-pass condenser, the "B" battery will also be short circuited, (2) a shorted turn in either coil A, B or C. One shorted turn will quite likely keep the oscillator from oscillating. (3) A high resistance connection in the oscillator tuning condenser or a short circuit in this condenser. The latter condition will also cause a short circuit on the "B" battery. (4) Loose springs in the tube sockets which cause an open circuit or a bad connection between the tube pins and the external circuit. (5) Reversed grid and plate connections.

The First Detector (Part 2, Fig. 12)

The circuit of the first detector is shown in Fig. 14. If you live close to a high-power broadcasting station, it is possible to pick the station up on the loop and the first detector alone. Open the plate circuit of the detector tube at point "x" (Fig. 14) and connect a head-set in series with the plate and the primary of the input transformer. Remove all of the tubes except the first detector. By pointing the loop in the proper direction, tuning the loop with the condenser C1 and listening carefully, the local station should be picked up.

If you are not close to a broadcasting station it will be necessary to use either a buzzer-driven wavemeter or a home-made source of modulated power. The buzzer-driven coil and

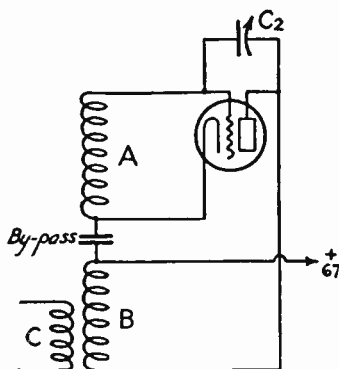

THE OSCILLATOR

Fig. 13—Diagram of Oscillator connections.

condenser combination shown in Fig. 15 will function over the whole broadcast band. Place the coil near the loop and in inductive relation to it, connect the battery to the buzzer and set the shunt (tuning) condenser across the coil (C in Fig. 15) at about one-half maximum capacity. Now listen with the head-set, varying the tuning condenser across the loop (C1, Fig. 14). Somewhere near 50 degrees on the dial of the loop tuning condenser, the signal from the buzzer should be picked up. If it is not, retune the wavemeter, setting the condenser at a lower capacity, and again try to pick up the buzzer signal in the head-set. If it cannot be heard there is some serious trouble in the first detector circuit.

See that the variable condenser C1 is OK. It must not be open or short circuited. The pick-up coil C must not have any shorted turns. The primary of the input transformer must not be open circuited. Test it with a head-set and battery. And lastly see that the grid condenser is OK and that the grid leak is of the proper value and is not open or shorted.

Testing the Detector and Oscillator

(Parts 1 and 2, Fig. 12)

When the first detector has been put into operation and the oscillator circuit has been carefully checked and found to be OK, the two can be tested together. Start the buzzer once more. Insert the oscillator tube in its socket and listen, again, in the plate circuit of the first detector. Tune the buzzer signal by by

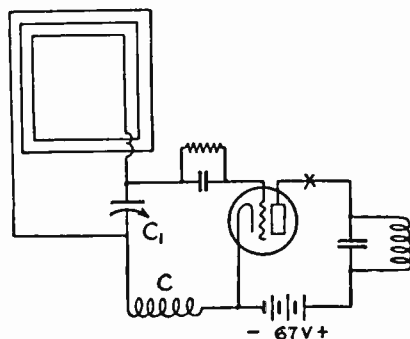

Fig. 14—Diagram of the First Detector.

means of the loop tuning condenser and then vary the oscillator tuning condenser (C2, Fig. 13). At a certain setting of the oscillator condenser, the buzzer signal will become muffled and will sound just as a spark signal sounds when the regenerative control on a regenerative receiver is advanced until the tube oscillates. Check this oscillation condition at both the lower and upper ends of the loop tuning condenser by setting the loop condenser first at 100, varying the buzzer condenser until the buzzer signal is picked up in the head-set, and then varying the oscillator condenser until the buzzer signal becomes indistinct and muffled. Then set the loop tuning condenser at about 5 or 6 degrees and repeat the above process, making certain that the oscillator muffles the buzzer signal at this condenser setting.

THE INTERMEDIATE FREQUENCY AMPLIFIER AND SECOND DETECTOR

(Parts 3 and 4, Fig. 12)

The intermediate frequency amplifier and the second detector are usually tested at the same time. If the intermediate frequency amplifier is properly wired and if the tubes are OK and the battery voltages correct, there is very little likelihood of trouble. When the potentiometer slider is turned completely to the left (or to the right, depending on how its terminals are wired) the intermediate frequency amplifier will go into oscillation. This oscillation will generally be accompanied by several long wave telegraph stations, as the coils of the intermediate amplifying transformers are large enough to pick up these high power signals without any antenna.

If the amplifier will not oscillate, test all of the sockets to see that the tubes make contact with the socket springs. See

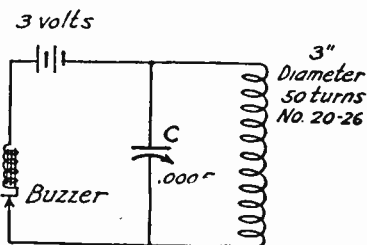

Fig. 15—Diagram showing Buzzer Arrangement for testing purposes.

that none of the connections between the transformers and the sockets are reversed (it is particularly important that the intermediate frequency transformer terminals marked "G" be connected to the grids of the tube sockets). See that the condenser C4, Fig. 16, is not open or short circuited and that the by-pass condenser between the potentiometer slider and the positive "A" battery lead is properly connected and is not open or shorted. The grid condenser in the grid circuit of the second detector should have a capacity of .00025 mfd. and should be used with a grid leak having a resistance from 2 to 10 megohms. A rather large by-pass condenser must be used across the headset (or output circuit and the "B" battery), as the amount of radio-frequency current in the plate circuit of the second detector is usually quite large. A .002 mfd. condenser usually will not be large enough to by-pass all of the R. F.—use a .005 or .006 mfd. condenser to start with.

94
+
x

If the amplifier oscillates continually and cannot be stopped there are some undesired feed-backs between grid and filament or plate and grid circuits. All of the plate and grid leads from the transformers to the sockets should be run in as short and direct a manner as possible, taking care, however, not to parallel these leads. The transformers should not be mounted closer than 2 inches from center to center, unless they are enclosed in metallic cases which are connected to each other and to the negative of the "A" battery.

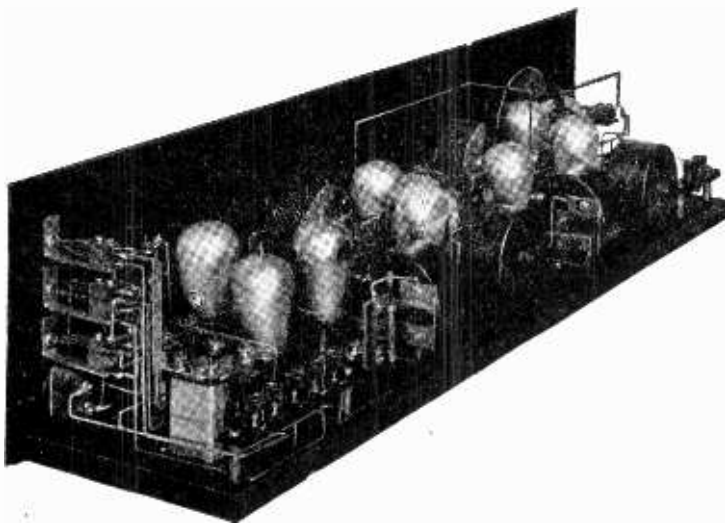

Plate II—This is a rear view of the panel showing the arrangement of the parts for an 8-tube Ultradyne receiver.

The Input Transformer

The intermediate frequency amplifier may be operating properly and still it will oscillate if the input transformer is not properly tuned; or if the proper coupling is not provided between the primary and secondary coils. There are some Super-Heterodynes that use the same type of I. F. transformer all the way through and still others that use a sharply tuned output transformer instead of a sharply tuned input transformer. The instructions here given can be readily modified by the student who is dealing with such a set.

For a 30 K. C. (10,000 meter) intermediate frequency no better input transformer can be constructed than one having a

1,250 turn honeycomb coil in the primary and a similar coil in the secondary circuit (Fig. 17). The outside end of the primary coil should be connected to the plate of the first detector and the outside end of the secondary to the grid of the first radio-frequency tube. The coils should be mounted so that the distance

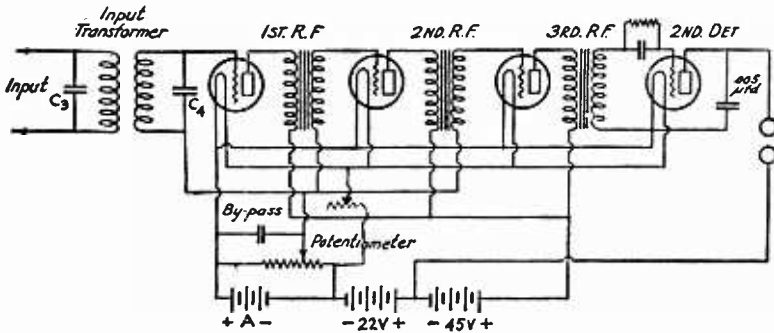

THE INTERMEDIATE FREQUENCY AMPLIFIER

Fig. 16.

between them can be varied up to four inches. This rather loose coupling is not generally required, but under certain conditions the only way in which the proper selectivity can be secured is by loosening the coupling to this extent.

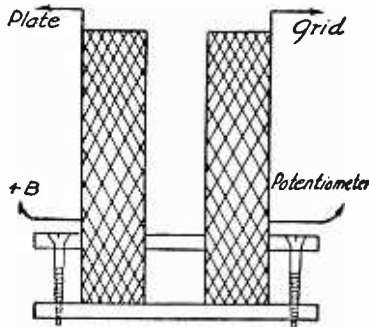

Fig. 17—This illustrates the connection for the four lead wires coming from the input transformer.

Both primary and secondary coils are shunted by .00025 mfd. fixed condensers. This value is rather critical. Do not rely upon the manufacturer's stamping of ".00025 mfd.," but try different condensers of this capacity until the correct one is found. Some of the small fixed condensers on the market—both paper and mica—have been made to fit the popular demand for

a cheap condenser. When one pays for something cheap one generally gets something cheap. In a set so highly expensive as a Super-Heterodyne it is well to order special condensers that are guaranteed to have a capacity within 10 per cent. (or less) of their rating. They cost a bit more but they are worth the added cost. A change in this shunt capacity of only 10 mmf. will make a lot of difference in both the signal strength and the selectivity, as will also the coupling between coils.

THE AUDIO-FREQUENCY AMPLIFIER

With a single stage of audio-frequency amplification, the signals from stations within a distance of 500 miles will be uncomfortably loud. For loud-speaker volume for the average room

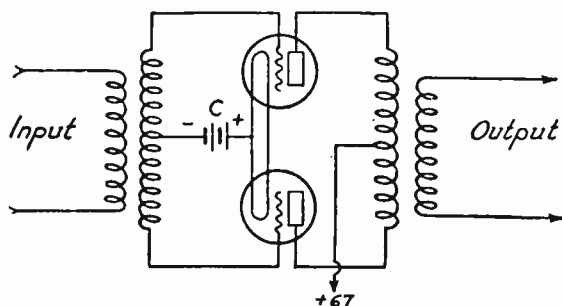

Fig. 18—Wiring diagram for push-pull audio amplifier.

a single stage of audio amplification is ample. If greater amplification is desired an additional stage may be added. This stage should be connected in the so-called push-pull fashion using two tubes and two transformers as shown in Fig. 18 in the one stage. If more than 45 volts are used on the plates of the audio tubes, a "C" battery will be needed. This "C" battery should have the proper voltage, depending on the plate voltage and type of tubes used.

Shielding

So far we have not mentioned shielding. Most people (and manufacturers, too) go at the shielding in such a half-hearted fashion that it might just as well be left out of the set entirely. The shielding, to be any good at all, *must* be thoroughly done. It is *not* satisfactory to merely enclose the whole intermediate

holes for the shafts of condensers, rheostat, and potentiometer are large enough to avoid any contact between the shielding and the metal parts of the instrument.

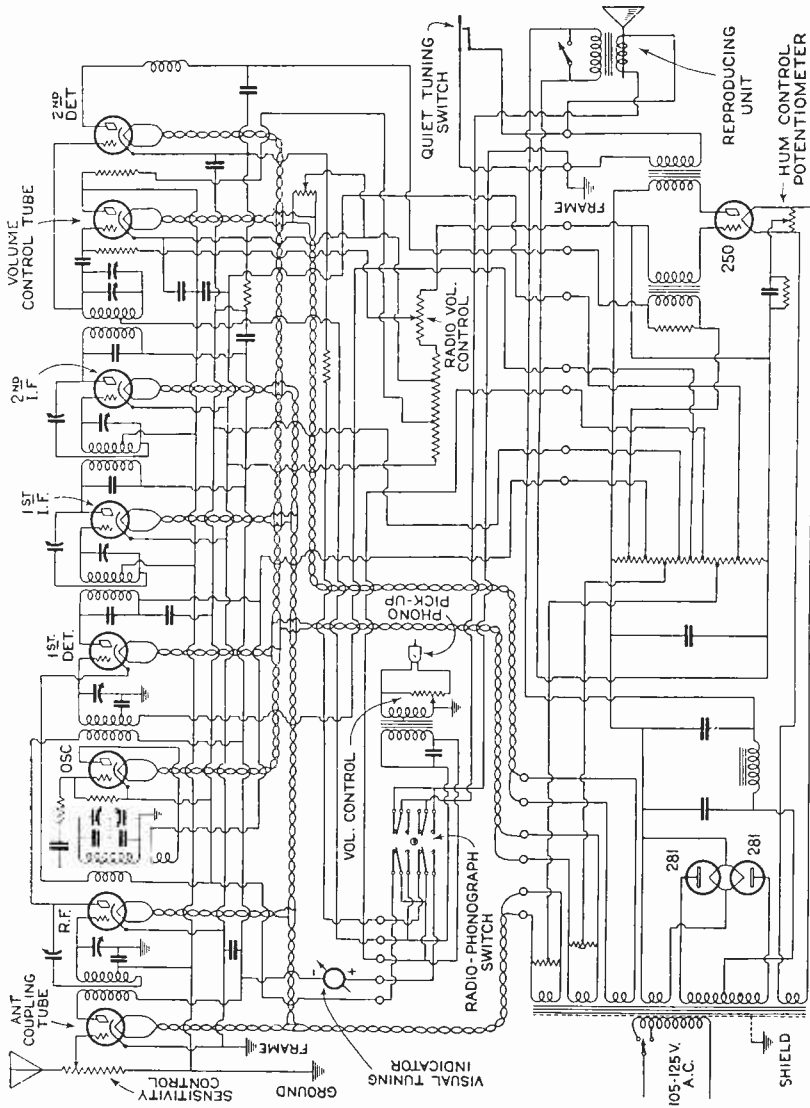

Fig. 21—Schematic diagram of the Radiola 64. A. C. Super-Heterodyne Receiver.

The upper shield forming the partition may be cut from this same copper in the form of squares or rectangles, and soldered in place against the baseboard and panel shield. See Figure 19.

The first compartment contains the oscillator, tuning condenser, the oscillator tube and oscillator coupler. The second compartment contains the loop tuning condenser, first detector tube and the terminals for the loop, while the third compartment holds the input transformer, the three intermediate frequency transformers and the three intermediate frequency tubes. The last compartment holds the rheostat, the second detector and the terminal strip for the "A" and "B" battery connections. All "A" and "B" and potentiometer wires should be run in a "cable" made of flexible wires, insulated, and laced together with string. The shielding material itself should be used as the negative "lead" of the battery. All connections going to the negative "A" should be soldered directly to the shielding.

If shielding is done in this manner, the volume and selectivity of the set will be increased fully fifty per cent.

TEST QUESTIONS

Number your Answer Sheet 26 and add your Student Number.

1. What improvement would you suggest for loop antenna used with a Super-Heterodyne receiver?
2. Show the wiring diagram for adding one stage of R. F. to the Super-Heterodyne set.
3. What kind and where can a R. F. choke coil be used in the 2nd detector circuit to prevent howling?
4. How may one protect the set from pick-up from the oscillator?
5. Show by diagram the method of testing a rheostat or potentiometer for open circuit or bad contact.
6. What happens when the grid circuit is open?
7. What is the advantage and also the disadvantage of reflexing the Super-Heterodyne set?
8. Name five sources of trouble in the oscillator circuit.
9. What causes an I. F. amplifier to oscillate continually?
10. What effect has shielding on the set and what kind of metal is used?

