

NATIONAL RADIO INSTITUTE

Complete Course in
PRACTICAL RADIO



Radio-Trician

(Registered U. S. Patent Office.)

LESSON TEXT No. 21

THE
SUPER-HETERODYNE
RECEIVER
DEVELOPMENT, DESIGN
AND OPERATION

Originators of Radio Home Study Courses
... Established 1914 ...
Washington, D. C.

SOME GOOD STUDY HABITS

A Personal Message from J. E. Smith

Pausing for Thought. Concentration in study, as I use the term does not mean a steady reading without pause. One ought to stop and turn over in his mind what he has been reading. That is the only way to insure that the ideas you have gained, or think you have gained, are really clear to you. It is the only way, too, in which you can make them genuinely your own and be able in the future to apply them to circumstances in which you may be placed.

Copyright 1929, 1930

by

NATIONAL RADIO INSTITUTE

Washington, D. C.

Radio-Trician's

(Registered U. S. Patent Office.)

Complete Course in Practical Radio

NATIONAL RADIO INSTITUTE

WASHINGTON, D. C.

THE SUPER-HETERODYNE RECEIVER

In previous lessons, you learned about the two general types of amplification used in radio reception, namely, radio-frequency amplification and audio-frequency amplification.

Audio-frequency amplification is used to build up volume after the signal has been received and rectified by the detector. It is possible to take a weak signal from the detector and pass it through several stages of audio amplification so that it can be heard several blocks away. However, two or three stages are about all that may be used successfully in a radio receiver. When more than this is used, the amplifier itself becomes noisy and the quality of signals is destroyed unless special precautions are taken.

If there is no signal in the detector, no amount of audio-frequency amplification will bring it out. The incoming signal has to be of a certain minimum intensity before detector action takes place. In other words, there is a certain entrance value that signals must attain before they can be heard in the detector. Here is where radio-frequency amplification becomes very useful.

This type of amplification is used ahead of the detector tube, between it and the aerial or loop, as the case may be. The function of radio-frequency amplification is to amplify and bring out the weak signals that otherwise might not affect the detector tube and accordingly would be too weak to be received. Radio-frequency amplification will build up and amplify radio-frequency impulses regardless of their strength. Therefore, it becomes very valuable in long distance radio reception.

However, we are dealing here with a much more difficult type of current. An extremely weak current of very high-frequency is a difficult thing to handle. It delights in jumping about from one wire to another, if the slightest opportunity is given it, and very often is dissipated throughout parts of the receiving set, where it is of no use whatever. It must be handled with extreme care and the higher the frequency of

the signal—that is the lower the wave-length, the harder it becomes to amplify at radio frequencies. Therefore, while this system is theoretically ideal, it has been very difficult to work out a satisfactory system for accomplishing this radio-frequency amplification on wave-lengths much below 600 meters.

The lower these wave-lengths became, the greater were the difficulties encountered. These difficulties can be attributed chiefly to the capacity effects in the vacuum tubes themselves as well as in the wiring and between the various instruments that make up the receiver. As the wave-length decrease the frequency increases, and the higher the frequency, the greater is the tendency for the weak radio impulses which we are trying to conserve and build up, to leave their proper path and jump to some nearby point from which they may pass to ground or otherwise become lost.

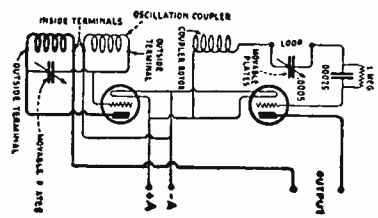

Fig. 1—Circuit Diagram of an Oscillator and Frequency Changer.

Indeed, at these high frequencies even small capacities between wires are nearly as bad as having these wires directly short-circuited, for the higher the frequency, the less capacity is needed to by-pass it.

The principal methods for amplifying broadcast wave-lengths at radio-frequency are *tuned radio-frequency amplification*, *untuned transformer-coupled amplification* and *resistance coupled amplification*. Fig. 2 illustrates the first plan, namely, tuned radio-frequency amplification. Two stages are shown before the detector. However, two or three stages of such a method offer sufficient difficulties. Such an amplifier is extremely selective. If any one of the tuned circuits is not exactly in resonance, amplification will be destroyed and, in fact, the signal may be completely lost.

However, when each of these circuits is tuned and the full amplification from each tube is realized, there is another difficulty in the way. The internal capacity of the tube pro-

duces feed-back between the plate and grid circuits which is sufficient to produce radio-frequency howling. It is almost impossible to avoid regeneration at such high frequencies without introducing some neutralizing force. Regeneration results in oscillations which spoil quality of signals and reduce over-all amplification.

The next method is to employ straight R. F. transformer coupling as in Fig. 3. Even such a system has a tendency to regenerate and produce radio-frequency howling. But, even if it did not oscillate, it has one disadvantage. Radio-frequency coupling transformers will give amplification only over a very

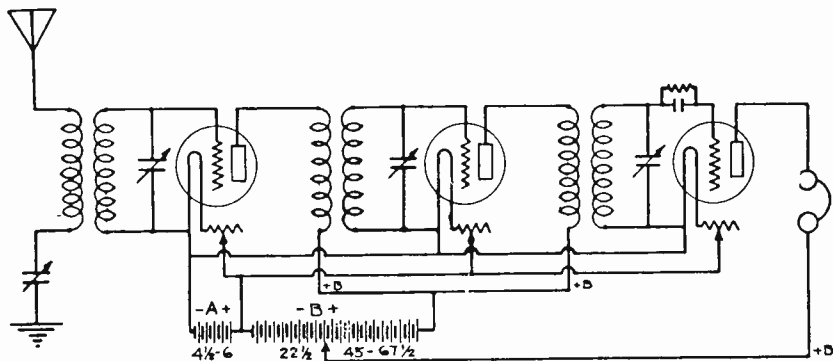

Fig. 2—A Two-Stage Tuned Radio-Frequency Amplifier and Detector With Grid Circuits Tuned.

narrow band of wave-lengths. Maximum amplification is secured at one wave-length, and then falls off as this wave-length is departed from. We, therefore, cannot avail ourselves of the full amplification of the tube at all wave-lengths with this system.

The third alternative method of radio-frequency amplification is straight resistance coupling as in Fig. 4. But at high frequencies corresponding to the broadcast wave-lengths, this has one very great disadvantage: it does not amplify very well. A resistance-coupled amplifier does not amplify well at these frequencies because the capacity of the tubes from plate to filament and from grid to filament partially short-circuits the amplified voltage. Thus, in Fig. 4, consider the coupling resistance R , which is of the order of 50,000 ohms. The amplified voltage is devoted across this resistance and applied to the grid of the succeeding tube, *provided* there is nothing to stop this voltage. But actually we have in parallel with this resistance R , two capacities: (1) The plate-filament

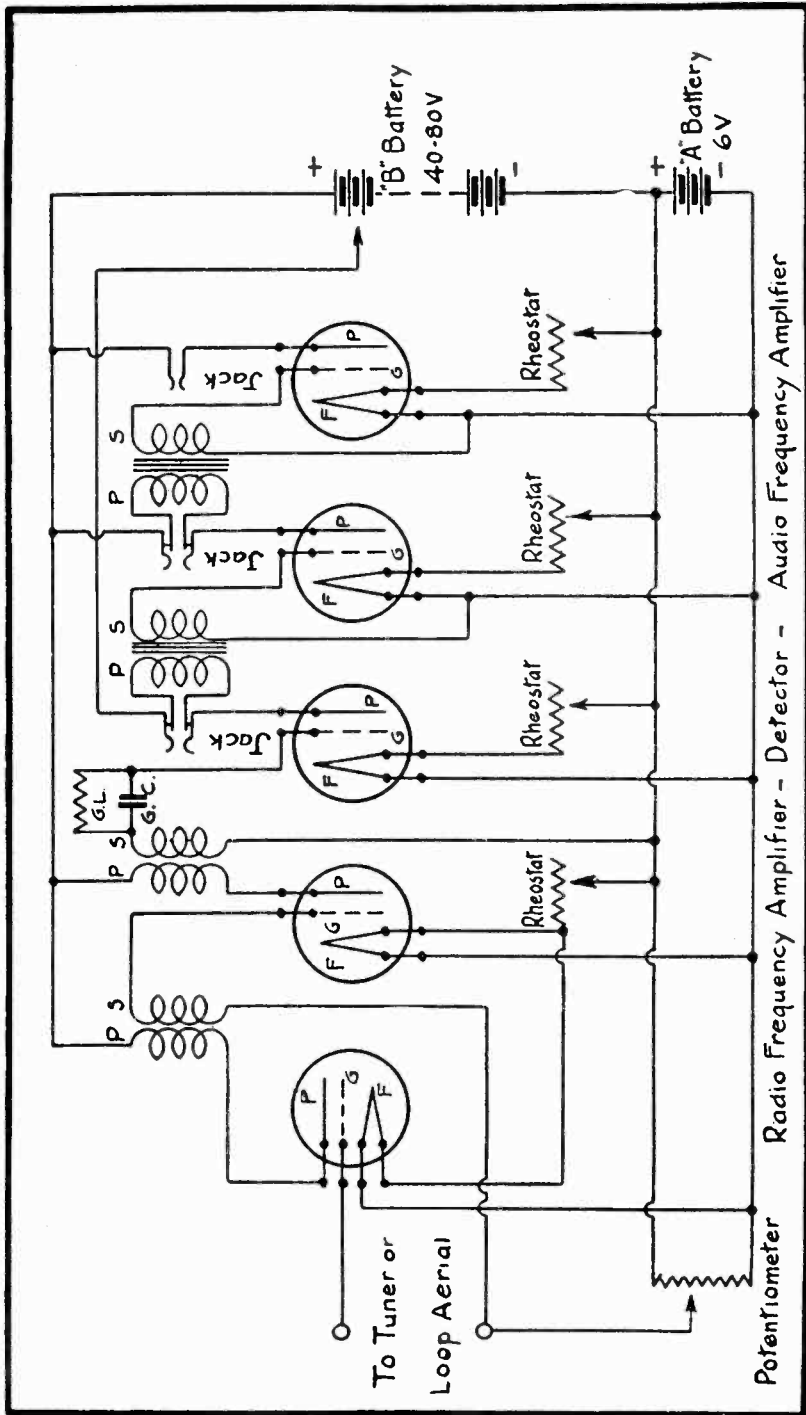

Fig. 3—Diagram of Two Stages of Untuned Radio-Frequency Amplification, Detector, Two Stages of Audio-Frequency.

capacity of tube A, and the grid-filament capacity of tube B. These capacities have no influence on the voltage across R at direct currents or audio-frequency currents because their reactance is so great. However, at radio frequencies, their reactances become so small that they practically short-circuit the resistance R and hence destroy amplification. Approximate values for plate-filament capacity and grid-filament capacity are 4 micro-microfarads and 6 micro-microfarads, respectively. Since they are in parallel, the total is 10 micro-microfarads. The reactance of this capacity at 200 meters is about 10,600 ohms. In other words, our coupling resistance R of 50,000 ohms or more is short-circuited by a reactance of 10,600 ohms which is less than the internal impedance of the tube. Hence, little amplification at these frequencies can be

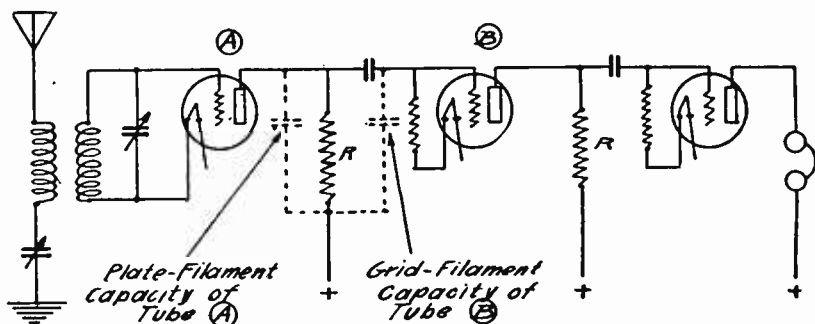

Fig. 4. Resistance Coupled R. F. Amplifier

secured. Students who have wondered why resistance-coupled R. F. amplification at low waves is not practical will now see the reason for it, and will also understand why it operates better at very long waves, for at very long waves the reactance of the tube capacity is high compared to the coupling resistance R, and hence does not short-circuit the voltage.

We now readily understand some of the obstacles which were in the way of developing radio-frequency amplification at broadcast wave-lengths. Numerous attempts at a solution have been made all over the world, and some of these are both of importance and interest. One of these solutions attempted to broaden the band of wave-lengths received and amplified by making a radio-frequency transformer wound with resistance wire. The effect of the resistance winding was to change the amplification curve from that of Fig. 5-(a) to that of 5-(b). The same effect was secured by using radio-

frequency transformers with an iron core, the losses in the iron core being equivalent to resistance losses. This resistance effect also partially prevented regenerative action in the amplifiers.

Armstrong attacked the problem of radio-frequency amplification from an entirely different angle. Radio-frequency amplification at long waves had proved very successful. If some means are used for converting the incoming wave into a long wave-length then the problem of R. F. amplification would be solved. *This meant a conversion of the high-frequency into a low-frequency.*

Such conversion of frequency had been practiced for some time in C. W. heterodyne reception, in which the phenomenon of beats is used. For example: If a continuous wave oscillation of a frequency of 100,000 cycles per second is combined with another of 99,000 cycles per second, then the well-known phenomenon of beats is produced, and the result of these two oscillations is another oscillation whose amplitude varies at a frequency equal to the difference of the two component frequencies. In this case the difference between 100,000 and 99,000, is 1,000 cycles. Thus, a 1,000-cycle note will be heard.

The Super-Heterodyne receiver makes use of the beat principle. A local oscillator is used to generate radio-frequency oscillations differing slightly from the frequency of the incoming signal oscillations. The incoming signal oscillations are combined with those of the local oscillator and another frequency is set up which is the difference between the frequency of the incoming signal and that of the local oscillator. This beat frequency is then passed through several stages of radio-frequency amplification and is amplified at radio-frequency. It is then detected and amplified by one or more stages of audio-frequency amplification.

Suppose the incoming signal has a frequency of 700,000 cycles, and suppose also that we have an oscillating circuit capable of generating oscillations over a range of frequencies. If the oscillator is set for a frequency of 650,000 cycles and its output is coupled to the receiver carrying the 700,000-cycle signal, then according to the heterodyne principle explained above, the output will be an oscillation whose amplitude varies at a frequency equal to the difference of the component frequencies, namely, 700,000—650,000, or 50,000 cycles (50 Kcs.) The only change that occurs is that by means

of an external oscillator a 700,000-cycle signal is converted into a 50,000-cycle signal of the same characteristics as the original 700,000-cycle signal. Thus, a high frequency signal is converted into a low frequency signal, and, since R. F. amplification is efficiently accomplished, this is a solution to our original problem. For, if we use a 50,000-cycle (50 Kcs.) R. F. amplifier, to amplify the 50,000-cycle beat oscillations, and then detect and rectify them, we will hear the original signal of the 700,000-cycle wave.

The above explanation will be readily understood in the case of the 700,000-cycle signal and the 650,000-cycle oscillator. Suppose one happens to be receiving, not a 700,000-cycle signal, but, say, at 610,000-cycle signal. What then? The external oscillator is adjusted so that it will oscillate at 690,000 cycles per second, in which case the difference between the

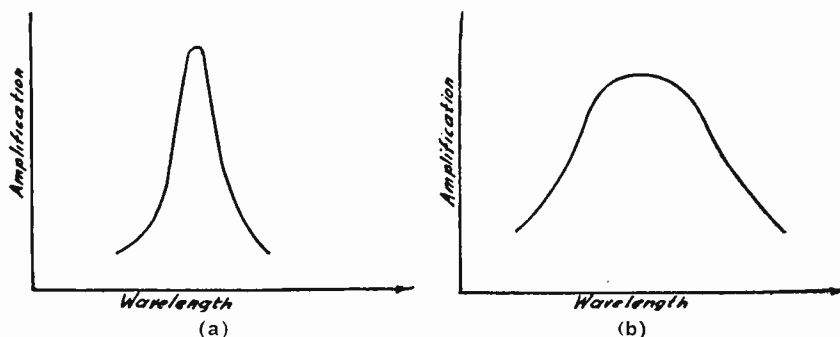

Fig. 5—Amplification Curves. (a) With Ordinary R. F. Transformers (b) With Transformers Wound With Resistance Wire or Having Iron Cores.

two, or the beat oscillations, will be 50,000 cycles as above, which frequency is capable of efficient amplification. Of course there is no necessity for this particular frequency of 50,000 cycles to be chosen. Any other frequency, such as between 30,000 and 100,000 cycles, could just as well be chosen. The important point is that the beat frequency, which is called the "intermediate frequency," should correspond to a low-frequency at which radio-frequency amplification may be accomplished more efficiently.

THE THREE DIVISIONS OF THE SUPER-HETERODYNE

The Super-Heterodyne as a whole, and as we are accustomed to use it at the present time, may be, for convenience sake, divided into three distinct parts. By taking these up separately and studying their individual functions, the stu-

dent can more easily grasp the significance and importance of each.

I. In the first section, we may place the input tuning apparatus, the frequency changing and oscillating tubes, together with their auxiliary apparatus, such as oscillator, coupler, tuning condensers, etc. (See Fig. 1.) The first tube in the Super-Heterodyne is commonly called the first detector, although it is a somewhat confusing and misleading name. As it is difficult for the average person to understand why there should be two detectors in any set, it is much more reasonable to consider the first tube merely as a frequency changer or a mixer for the two wave-lengths with which we have to deal, namely, the incoming wave-length and the wave created by our local oscillator. The incoming wave, which is picked up by a loop or antenna, as the case may be, is fed into the frequency changing tube, and the local wave which is being produced by the oscillator tube is likewise fed into the frequency changing tube. These two wave-lengths are so combined here as to create a resultant higher wave which may be adjusted to any desired frequency by slightly changing the wave-length of the local oscillator, whose wave-length is increased as the capacity of the condenser across the oscillator coil or coupler is increased and vice versa. This predetermined intermediate wave may be almost any wave-length above that of the incoming signal. The wave-lengths which are in common usage today for this purpose usually lie between 1,500 and 10,000 meters.

Thus it is seen that the function of the first part of our Super-Heterodyne is to tune in and receive the desired signal with the tuning apparatus, which may consist of either a loop and tuning condenser, or antenna tuning coils, such as a variocoupler with its tuning condenser. Then by means of the local wave, generated by the oscillator tube, to change the received signal to some predetermined higher wave-length at which we propose to amplify it.

II. The second division of the Super-Heterodyne is the intermediate wave amplifier (see Fig. 6) whose function is to amplify the longer wave-length signal which is passed on to it from the first section. In other words, after the signal has been received and changed to some predetermined longer wave-length, the first section has done its duty. It then passes this changed frequency signal on to the second section, the

X
V

intermediate wave amplifier, where it is amplified as much as we desire. This amplifier is the engine of the Super-Heterodyne and it is here that the energy is amplified and the signal built up in amplitude preparatory to its rectification in the final detector tube. This amplifier is designed with two things in view—

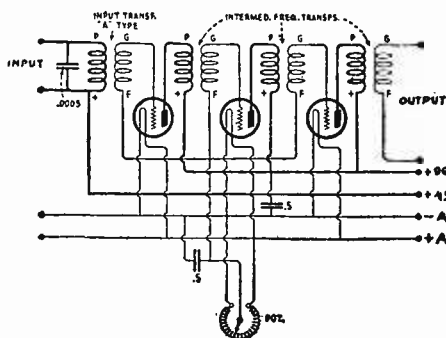

Fig. 6—Intermediate Wave Amplifier.

First: To give as great efficiency in amplification per stage as is possible.

Second: To do this without distorting the wave form, that is the signal must be built up, amplified and passed on from tube to tube throughout the amplifier without introducing any false harmonics or eliminating any of the desirable ones.

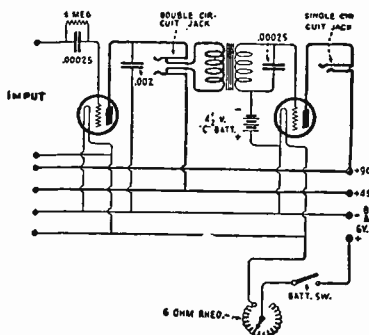

Fig. 7—Detector and a One-Stage Audio Amplifier.

III. The third division is composed of a detector tube and audio-frequency amplifier, if we desire power for the operation of a loud-speaker (see Fig. 7). The signal which is built up in the intermediate amplifier is fed into this third section and rectified here by the detector tube. That is, it is changed from an alternating high-frequency wave to an

audible pulsating direct current, which should correspond exactly to the modulations of the high-frequency waves. This is done in order to change it into a form of current that will allow it to actuate the diaphragm of our receiver or loud-speaker, giving us a faithful reproduction of the voice or music, as the case may be, as it was originally produced at the transmitting studio. The function of this detector tube and its following audio-frequency amplifier is practically the same as in any radio receiving set and its action is quite familiar. The only point to be noted here is that there is no advantage gained by using a soft or gaseous detector tube at this point, as we no longer have weak impulses of small amplitude to deal with. The wave which reaches this final detector tube is always of great amplitude even at its minimum, due to the heterodyne action of the oscillator and the amplification which it has undergone.

THE OSCILLATOR

The function of the oscillator is to generate a frequency slightly different from the frequency of the incoming signal so that a beat frequency is produced. This oscillator is nothing more than the essential parts of a transmitting set, with a small coupling coil called the pick-up coil. Any reliable circuit may be used such as the Hartley or Meissner. It should oscillate freely over the entire scale of wave-length that it is intended to receive. It is tuned by a variable condenser. The pick-up coil is used to transfer the oscillator energy to the first detector where it is mixed with the incoming signal and the resultant frequency produced.

THE INTERMEDIATE AMPLIFIER OR THE HEART OF THE SUPER

Now the heart of the Super-Heterodyne is the middle unit, which as we have already stated above, is comparable to the engine which gives the car its power. It is the intermediate frequency amplifier which we depend upon to furnish the amplification which is characteristics of this receiver and it is this section which should be given the most attention and consideration.

MAINTAINING QUALITY IN THE AMPLIFIER

As has already been stated, there are two basic general requirements that should be met in any amplifier. As they

are the fundamental requirements, it will be well to repeat them. They are roughly as follows:

1. In order to build up maximum voltage and maintain maximum selectivity, the interstage transformers should be designed to tune sharply.

2. The received signal must not be distorted as it passes through the amplifier. This means in the case of the intermediate frequency amplifier that the modulation frequency component of the received signal must not only be passed through the transformers, but must also receive an approximately uniform degree of amplification.

This latter consideration is of the utmost importance when considering an amplifier for use in the Super-Heterodyne, for here we must handle frequencies that are relatively low where it is comparatively easy to cause distortion of this nature and as we are considering the reception of radiophone signals, quality reproduction is one of the first considerations.

SHARP TUNING VERSUS DISTORTION

In order to maintain good quality reproduction, the intermediate frequency amplifier must not be tuned too sharply. Since the modulation frequencies extend on either side of the carrier wave frequency it is, therefore, necessary that the intermediate frequency transformers amplify equally well over a narrow band of frequencies to either side of the carrier frequency. As an example, suppose that the modulation frequencies extend from say something like 30 to 10,000 cycles. This means then that if the intermediate frequency is 50 kilocycles (50,000 cycles) that the intermediate frequency amplifier must pass without discrimination all frequencies between 40 and 60 kilocycles, since 50 kilocycles minus 10 kilocycles equal 40 kilocycles and 50 kilocycles plus 10 kilocycles equals 60 kilocycles. This is the ideal condition and the average intermediate frequency amplifying transformer will not pass these frequencies equally without giving preference to some frequencies over others.

If the amplifier does not pass these frequencies and amplify them equally then some of the upper voice frequencies are cut off and the high pitch notes are not reproduced.

WHY THE SUPER IS SELECTIVE

The underlying principle of the Super-Heterodyne is that the frequency of the signal wave is changed to a much lower

frequency and then amplified before being detected and amplified at audio-frequency. The ordinary receiver amplifies the signal without changing its frequency. As previously explained, the intermediate frequency is obtained by mixing with the signal another frequency current which is different from the signal frequency by the amount of the intermediate frequency. As an example, suppose that the signal frequency is 1,000 kilocycles and the intermediate frequency transformers are designed to operate on 50 kilocycles. Therefore, if we tune the oscillator so that it generates a high frequency current which is different by 50 kilocycles from the signal frequency, we will have an intermediate frequency of 50 kilocycles. Thus the oscillator can be tuned either to 950 kilocycles or to 1,050 kilocycles.

In the mixing of the oscillator and signal frequency, in order to obtain the intermediate frequency, it can readily be understood that in changing the signal frequency to the intermediate frequency all outside currents having a different frequency will not be combined into the intermediate frequency. First, due to the fact that the oscillator frequency is very sharp and does not cover a wide band of frequencies and next due to the fact that the intermediate frequency amplifier is so constructed that the band of frequencies which it will amplify is limited. Thus, selectivity greater than that of the ordinary tuned radio-frequency receiver is gained.

TUBE NOISES AND STATIC INTERFERENCE

The limiting factor of distant reception with a Super-Heterodyne can be summed up in two words—the noise level. If the radio-frequency noises such as static and atmospheric disturbances impress a much stronger voltage on the antenna than the signal the reproduction will not be very pleasant. This applies to all types of receiving sets as well as the Super-Heterodyne. This relation between the static or atmospheric noises and the signal is often referred to as the “noise level,” “signal-noise ratio” or “signal-static ratio.” In other words, the greater the strength of the signal in comparison to the static, the better is the reception.

Now the higher the wave-length which is used, the lower the frequency becomes, gradually approaching an audible frequency. Accordingly the higher the wave-length to which the amplifier is tuned, the greater is its tendency to amplify audio-frequency noises. In fact many radio-frequency trans-

formers which are designed for wave-lengths of 6,000 meters or greater are fair audio-frequency amplifying transformers and a three-stage audio-frequency amplifier even if its efficiency per stage is not great, can build up quite a volume of sound. This, of course, may be overcome to some extent by the use of an air core filter transformer in the amplifier output, but this does not correct it entirely. The real solution to this problem is to reduce the wave-length of the intermediate amplifier to such a point that comparatively low impedance air core transformers may be used which will not allow a large audio-frequency potential difference to build up across them and will accordingly result in a considerable increase in the signal-noise ratio. *This, as pointed out above, is the fundamental limit of the Super-Heterodyne's amplification powers and accordingly anything which increases the amplification of the receiver at a sacrifice of this ratio is hardly worth while.*

HAND CAPACITY EFFECT

There is another thing which we must take into consideration and that is the troublesome hand capacity effect on some sets.

This hand capacity or body capacity effect is very annoying in sets whose intermediate frequency amplifier works on 30 K. C. or 10,000 meters. Complete shielding of the oscillator and intermediate frequency amplifier is usually the only solution of this difficulty.

IMPORTANT TUNING CONSIDERATION

There is still another important point in favor of the low-wave amplifier. In heterodyning the incoming signal—changing its frequency suitable to use in the intermediate amplifier—we may use either the sum of the local oscillator frequency and the incoming wave frequency or their difference; that is, in actual practice there will be at least two places on the oscillator dial where any station may be received, providing the loop or antenna tuner, as the case may be, is not detuned from the station and also providing that the oscillator has sufficient range to cover both of these points. Now as the wave-length of the intermediate amplifier is increased, these two points at which the station will be reproduced come closer and closer together on the oscillator dial, until when we amplify at a wave-length of 10,000 meters, for instance, these two points are separated by only a very few degrees on

the oscillator dial. In fact, they are so close together that when tuning the set, the antenna tuner is not sufficiently far out of resonance by the time the second one is reached and consequently the station is brought in at two points close together. This is not only confusing to the operator, but it often happens that the station will come in again on its upper point exactly on top of the lower point of some other station, thus causing needless interference. Now the cure for this situation is to reduce the wave-length of the intermediate wave amplifier to such a point that a low wave station will not be heard again until the high broadcasting wave-lengths have been passed or at least until the two resonance points are so far apart that by the time the upper one is reached, the antenna or loop tuner is far enough out of resonance to prevent it from coming through again. Thus the local oscillator or heterodyne may be so designed as to merely cover the sum or difference of the oscillator frequency and the incoming wave frequency, and the operator is not bothered by having the low wave stations repeating on him when he is attempting to receive those on high wave-lengths.

STABILITY AND EFFICIENCY

The Super-Heterodyne owes its existence to the well-known fact that high wave-lengths are easier to handle at radio-frequencies than the low ones. In other words, as we go up in wave-length it becomes easier to build the radio-frequency amplifier and obtain stability and efficiency. However, this problem is not a serious one at any wave-length over 1,000 meters. In fact at any wave-length greater than this, even a resistance-coupled amplifier shows good efficiency and while it becomes easier to obtain a greater efficiency per stage as the intermediate wave-length is increased, at the same time we do this at a sacrifice of other desirable features, as have been pointed out above.

On the other hand there are several advantages of using iron core transformers in preference to air core transformers. This is especially true when their operating frequency is about 50 K. C. or 6,000 meters. A properly designed air core transformer has a sharp peak at which it amplifies most efficiently. In an efficient amplifier using these transformers all of these peaks must coincide. If one of them is out of resonance with the rest, the amplification falls off greatly, hence, the necessity for having all the transformers matched. Although it is pos-

sible to have a set of perfectly matched transformers, they may not be in resonance when connected into the circuit. The reason for this is obvious. The capacity effect between the wiring of the set is sufficient to throw the amplifier out of resonance. Also the external field of an air core transformer may be cut by that of another transformer or by some metallic object which will shift the resonant point. The greatest difficulty is experienced from tubes that have different internal capacity. This capacity is shunted across the transformer, thus increasing its wave-length. If different values of capacity are shunted across the different transformers, their peaks would not be in resonance.

One way to largely overcome this difficulty is to match the tubes or to shift the tubes around in the set until best results are obtained. There is quite a noticeable decrease in the wave-length of the intermediate frequency amplifier when the 199 type tube is used in place of the 201-A type. This is on account of the lower internal capacity of the 199 type.

The above difficulty is eliminated by using iron core transformers because these transformers have a sufficiently flat top peak that such capacity variations do not affect the amplification or throw the different stages out of resonance.

The iron core transformers cause the amplifier to be more stable in operation thereby permitting the grids to carry more of a negative bias. This causes the set to consume less "B" battery current. The battery consumption of the air core amplifier is from 40 to 60 per cent higher than with the iron core amplifier due to the use of a positive grid bias obtained by a potentiometer across the "A" battery. The potentiometer may be used with iron core amplifiers also, but in case it is, it has to be turned practically all the way toward the negative side to cause the amplifier to become unstable.

WHICH SHALL WE CHOOSE—HIGH OR LOW?

It can easily be seen that in order to draw a conclusion from the above considerations and pick a best wave-length for our amplifier, it is going to be necessary to make compromises. There are one or two considerations which would seem to indicate the high wave-lengths as being best, while on the other hand there are sufficiently strong arguments to make it well worth while to sacrifice something in order to gain the beneficial results which the low waves will give us. If we use a good high wave intermediate amplifier, we will obtain good

stability and large amplification per stage. On the other hand, to get this we have somewhat complicated the tuning and have *decreased our signal noise ratio, which after all seems to be the answer.* Amplification, sharpness of tuning and all other considerations are of little avail if our receiver brings in such a quantity of noise together with the signal that it is either unpleasant to listen to or even impossible to do extreme distance work when conditions are not perfect. *This one consideration alone is sufficient to indicate a comparatively low wave-length as the best.* However, if we carry this too far, we are going to sacrifice our sharp tuning, which is such a valuable characteristic of this type of receiver and on account of this latter consideration, a lower wave-length than 1,500 meters cannot be recommended. With the other points in view a higher wave-length than 8,000 meters also becomes undesirable.

The most satisfactory all around wave-length for an intermediate amplifier lies in a compromise between these two extremes of 1,500 and 8,000 meters. Such an amplifier will combine practically all of the desirable characteristics enumerated above.

TRANSFORMER CONSTRUCTION

For the benefit of any student who may contemplate building his own transformer, a few words about their actual construction and difficulties encountered will perhaps save time and trouble. In the first place if you are going to wind your own, choose a low wave-length, something in the neighborhood of 2,000 or 3,000 meters. This is not only on account of the points brought out above, but also because it is more practical and simpler to build a transformer for these wave-lengths with the limited facilities and equipment available to most people. This is mainly due to the fact that when the higher wave-lengths are used, it is almost imperative that an iron core in some form be used. This is done in order to flatten the curve sufficiently to prevent the transformers from distorting, which would be the case if they were tuned too sharply at the higher wave-lengths. While an iron core at radio-frequencies introduces a considerable loss, at the same time if the construction is carried out very carefully, thin laminations being used, each insulated from the other, this loss is well compensated for by the step-up ratio which may be used in the transformers themselves. However, the design of such transformers and the construction is rather difficult

and the materials hard to obtain, therefore, if one wishes to experiment with transformers, by all means buy them instead of trying to build them.

On the other hand, it is possible for the average person to build a set of fairly efficient transformers having their resonance point in the neighborhood of two or three thousand meters. This task is by no means a simple one and cannot be recommended to anyone who has not had some experience with this type of work. At the same time it is a very fertile field for experimentation for the man who takes pleasure in this sort of work. There is one important consideration in this construction work which is well worth calling attention to, that is the fact that these transformers are comparatively sharply tuned and it is necessary that their natural wave-length should fall within approximately 100 meters of each other. It is a physical impossibility to wind two coils to exactly the same natural wave-length, due to slight variations in the wire insulation, etc. If the mechanical dimensions of the forms are all the same and exactly the same number of turns are wound on each, the error will not be serious and they will almost always come within 25 or 30 meters of each other. However, it sometimes happens that one coil is wound considerably tighter than the others, or that wire from another lot or possibly a different manufacturer is used, which results in throwing it considerably out of resonance. A simple test for the transformers after they are wound may be made as follows:

Place the transformer in an oscillating circuit by connecting its secondary to the grid and filament of a vacuum tube and its primary to the plate and "B" battery of the same tube, placing a pair of phones in series with the plate circuit. We now have the transformer hooked up as it is in an amplifying circuit, with the exception that both primary and secondary are being used on a single tube instead of between two tubes, and as the primary acts as a feed-back or tickler coil, the circuit will oscillate providing, of course, the primary polarity is correct. Now by using a wavemeter and placing the wavemeter coil over the transformer, that is, just above it, the natural resonant frequency of the transformer may be measured by moving the wavemeter condenser until a click is heard in the phones. When the wavemeter is tuned to resonance with the transformer, it absorbs the energy in the oscillating

circuit and at one point stops the circuit from oscillating. This registers as a click in the phones. If there are two distinct clicks, the wavemeter is too close to the transformer and should be lifted until this narrows down to a single click, or two clicks which are very close together, in which case the proper wave-length is one-half way between the two clicks. When the wave-length is noted on the meter, the other transformers may be tested similarly in operation and if they should not fall together, the turns may be decreased on those of higher wave-lengths until they are all approximately matched.

It is not necessary to go through this procedure with the tuned transformer, as the condenser which is used to tune it, can be made to throw the wave-length of this transformer one way or the other to coincide with the rest. While it is not necessary to have the transformers closer than 100 meters, at the same time, due to the fact that when placed in the circuit, variations in tube capacities, sockets, wiring, etc., will make them vary, it is well to have them fairly accurately matched, then any slight variations will not be noticed.

FILTER TRANSFORMERS

A filter or tuned transformer is very necessary when the higher wave-lengths are used, and in this case it is best used in the output, that is immediately preceding the final detector tube. There are two reasons for this. First, as it is necessary to build the high wave inter-stage transformers so that they will cover a wide wave-length band, they give, of course, in themselves very broad tuning and it becomes necessary to have a sharply tuned air core transformer to determine the frequency at which the amplifier will function and to exclude other frequencies.

Second, due to the higher impedance of the longer wave transformers to audio-frequency impulses, such an amplifier will amplify static and other disturbances at an audio-frequency and this becomes very disagreeable when carried through three stages. This objection, however, can be somewhat overcome by using an air core filter transformer in the last stage, that is, coupled to the detector tube, which will have a tendency to suppress the audio frequencies.

The foregoing describes a standard Super-Heterodyne circuit. There is one change that is commonly made now that makes the circuit more sensitive and selective. This is accom-

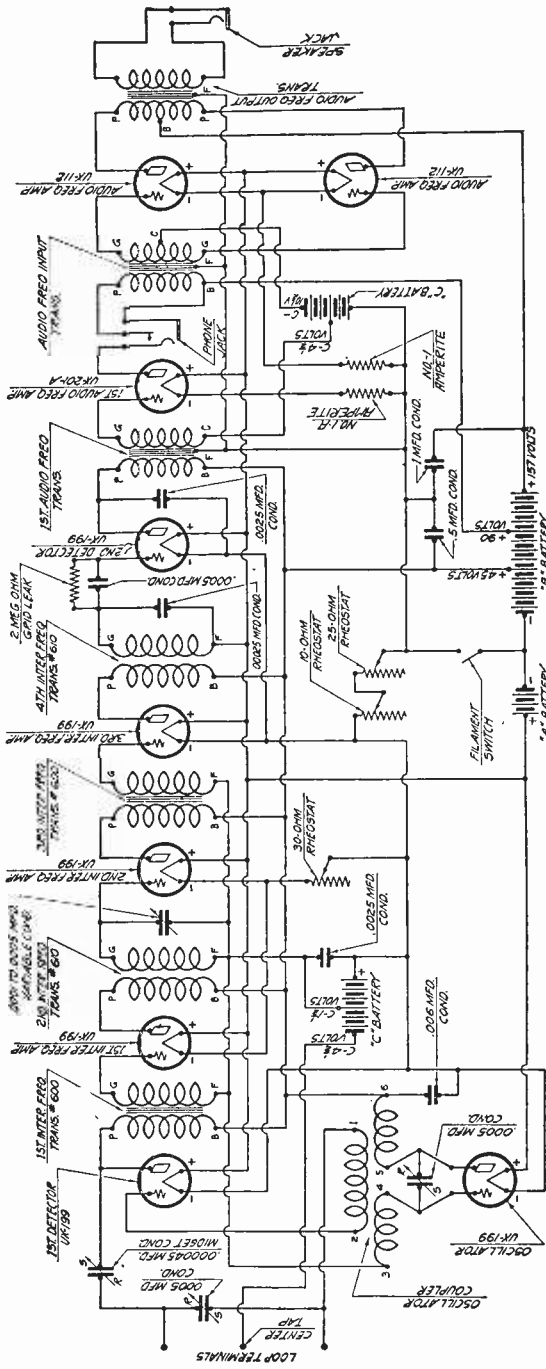

Fig. 7-(a)—Schematic Wiring Diagram of the Remler 45 K. C. Super-Heterodyne Receiver, Using the Rice Split-Loop to Obtain Regeneration.

plished by making the first detector circuit regenerative which increases the amplification considerably and sharpens up the loop tuning condenser. The Rice split-loop method is used or more commonly called the three tap loop method. Regeneration is introduced by a small capacity feed-back from the plate of the first detector through a midget variable condenser to one end of the loop.

If a circuit uses the filter transformer in the input, regeneration cannot take place if the filter transformer is tuned by a fixed condenser across the primary. If regeneration is desired in this circuit, the tuned stage must be placed at the output.

HELPFUL HINTS

While a good Super-Heterodyne is a very simple set to operate, once it has been properly built and adjusted, the layout of the apparatus and the mechanical difficulties encoun-

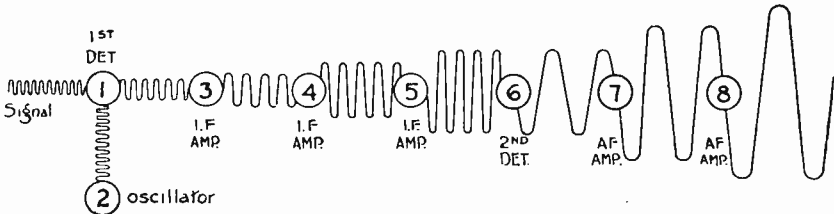

Fig. 8—How the Well-Known Phenomenon of Beats is Produced in a Super-Heterodyne Receiver.

tered in its construction—particularly when it is assembled as a single unit—make it a rather difficult receiver for the average experimenter to successfully construct at his first trial. Without aid he will invariably stumble over the innumerable small technical difficulties which he must necessarily encounter and overcome before his Super has attained that flexibility and ease of control for which it is noted.

VARIOUS TYPES OF THE SUPER-HETERODYNE

While all Super-Heterodynes are built on the same general principle, there are various modifications of them. The difference lies chiefly in the frequency changing section. We will consider a few of the most popular types.

The Ultradyne is a modification of the Super-Heterodyne. It is different in that the first detector does not receive its plate supply from the "B" battery but instead operates with an alternating current plate supply. This alternating current is of radio-frequency and is supplied by an oscillator of the usual

type. The action, as explained by Mr. Lacault, the inventor of the circuit, is that the incoming signal through the first detector modulates the radio-frequency from the oscillator. The principal difference of this circuit lies mainly in the absence of a direct current in the detector plate circuit.

The Radiola Super-Heterodyne has some features different from the regular type. This receiver uses a method of reflexing and by using the same tube for both the oscillator

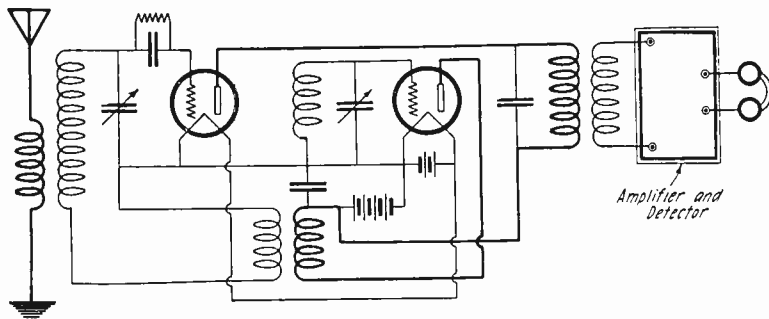

Fig. 8-(a)—Arrangement of the Oscillator and the First Detector in the Usual Super-Hetrodyne Receiver. Contrast This With the Ultradyne Arrangement, Shown in Fig. 8-(b).

and the first detector. This method is explained by Armstrong as follows:

“In view of our knowledge of the self-heterodyne, it appears quite obvious to perform the first rectification by means

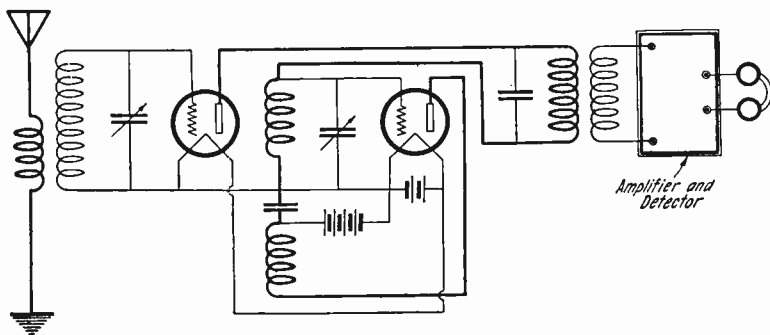

Fig. 8-(b)—Arrangement of the So-called Modulation System Used With the Ultradyne Receiver. No Pick-up Coil and Grid Condenser are Employed and no “B” Battery is Connected With the Modulator Tube, the Plate of Which is Supplied With High-Frequency Current From the Oscillator.

of a self-heterodyne oscillator and thereby save a tube. As a matter of fact, this was one of the very first things tried in France, but, except for very short wave-lengths, it was never very successful when a high intermediate frequency was neces-

sary. The reason was this: If a single tuned oscillating circuit was used, the detuning to produce the proper beat caused a loss of signal strength which offset the gain of a tube. If two tuned circuits were used on the oscillator, one tuned to the signaling frequency and the other arranged to oscillate at the heterodyning frequency, then on account of the relatively small percentage difference in frequency, a change in the tuning of one circuit changed the tuning of the other. The solution of this problem was made by Houck, who proposed an arrangement to connect two tuned circuits to the oscillator, a simple circuit tuned to the frequency of the incoming signal and a regenerative circuit adjusted to oscillate at such a frequency that the second harmonic of this frequency beating with the incoming frequency produced the desired intermediate frequency." The general arrangement is illustrated by Figure 9.

The circuit A is tuned to the incoming signal frequency. Circuit B is tuned to a frequency such that twice its frequency

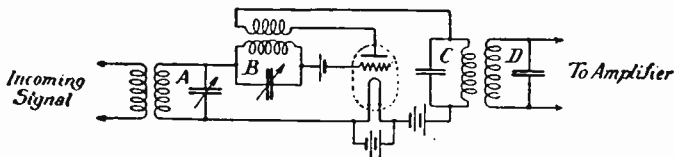

Fig. 9—The Fundamental Circuit of the Second Harmonic Method of Producing the Oscillator Frequency.

is different from the frequency of the signal by the amount of the intermediate amplifier. Thus, if the incoming signal frequency is 1,000 kilocycles and the intermediate frequency is 50 kilocycles, then 1,000 K. C. minus 50 K. C. equals 950 kilocycles. Since 950 is the second harmonic of the frequency to which the circuit B is tuned, then circuit B must be tuned to one-half this or 475 kilocycles. Also if circuit B is tuned to 525 kilocycles, the second harmonic of this is 1,050 kilocycles and when this is mixed with 1,000 kilocycles a beat note of 50 kilocycles is also produced.

By reason of the varied action of the tube, there are created in circuit B a variety of harmonics. The second harmonic combines to produce beats with the incoming signals of the desired intermediate frequency, the tube mixes them to produce the desired intermediate frequency and, through C and D, the new frequency is supplied to the amplifier. On account of the fact that circuits A and B are tuned to frequencies differing by approximately 100 per cent, a

change in the tuning of one has no appreciable effect on the tuning of the other. It can be seen from the foregoing that the action of the second harmonic system is fundamentally the same as the ordinary heterodyne system, the only difference being that one tube is used as a detector and oscillator and the second harmonic of the oscillator is used instead of the fundamental frequency. This is accomplished by having a circuit which is tuned to respond to the second harmonic instead of the fundamental. This arrangement solved the oscillator problem and, in addition, practically eliminated radiation.

The next step in the reduction of the number of tubes was to make the radio-frequency amplifier (first tube) perform the function of amplifying at the signal frequency as well as at

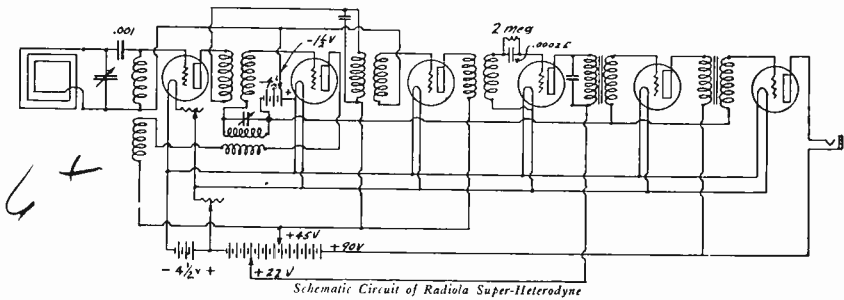

Fig. 10—The Schematic Circuit of the Radiola Super-Heterodyne. This is not a detailed wiring diagram of the set, but shows the general layout of a second harmonic type of Super-Heterodyne Receiver.

the intermediate frequency. This can be done with none of the difficulties inherent in audio amplification as the very small amplitude of voltage handled by the first tube precludes the possibility of the grid becoming positive with respect to the filament. The general arrangement of the circuits for carrying this out is illustrated by Fig. 10. In this arrangement, the signals received by the loop are amplified at radio-frequency by the first tube and applied to the grid of a second harmonic oscillator by means of an untuned radio-frequency transformer. The combined signaling and heterodyning currents are then mixed by the second tube producing a current of intermediate frequency which is applied to the grid of the first tube, amplified therein, and passed on to the second stage of the intermediate frequency amplifier. Thus, the first tube is reflexed and performs the action of double duty amplification. It amplifies the signal before it is heterodyned and

by having the tube reflexed it also amplifies the signal at the intermediate frequency.

There are several other types of Super-Heterodynes that use the self-heterodyne principle. Some of them go by the name of Tropadyne, Pressley, Silver Super-Autodyne, etc.

TESTING THE SET

The Intermediate Frequency Amplifier

Let us start by testing the intermediate frequency amplifier. Snap on the filament switch and turn the filament rheostat on until the tubes assume approximately their normal brilliancy. In the case of 201-A tubes, when a 6 ohm rheostat is used, this will be practically all the way around on the rheostat; but if a low resistance power rheostat is used, it should be approximately half on. Next, note the polarity of the potentiometer connections, and move the arm on the po-

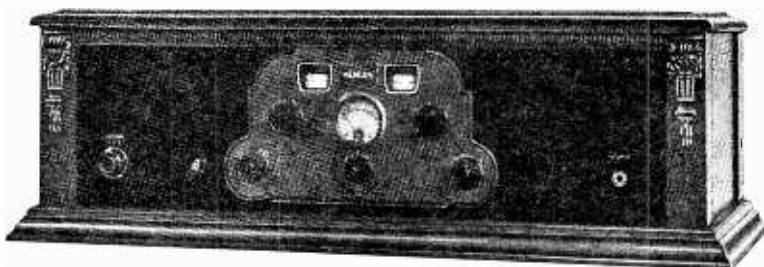

Fig. 11—Typical Super-Heterodyne Receiver.

tentiometer completely over to that side which is connected to the positive "A" battery line. Plug the receivers into the detector jack and proceed as follows:

Move the potentiometer arm gradually around toward the negative end. At approximately half way around, the amplifier should go into oscillation with a slight "hiss" or "click." If a grating sound is heard in the phones as the potentiometer is varied, the potentiometer winding should be cleared with a piece of fine sandpaper. The normal operation point of the amplifier is at the position just before the amplifier goes into oscillation, which is found by having the potentiometer arm just on the positive side of the click. If no "click" is heard and the wiring checks out O. K., look for trouble first in the potentiometer itself, making sure that there is an electrical connection between all three posts of the potentiometer, regardless of where the arm is placed. This may be tested

with a pair of phones and battery in series, after disconnecting the potentiometer. If the trouble does not lie here, test out the transformers by the same method. When phones and battery are connected across either the primary or secondary windings, a distinct sharp click should be heard—both when this connection is made and when broken.

Assuming that the amplifier is satisfactory, move the potentiometer arm just beyond the point of oscillation, toward the negative side. Now, the entire amplifier is oscillating, and, whenever the grid connection of any of the three radio-frequency transformers is touched, there should be a distinct thud as the finger touches and also as it leaves the post.

The Oscillator

Leaving the amplifier oscillating, test out the oscillator in the following manner: Place the rotor of the oscillation coupler almost all the way in; that is, so that the windings of the stator and rotor are nearly parallel. Now, vary the oscillator condenser slowly over the entire scale. If the oscillator is working properly—that is if it is oscillating—a succession of whistles or heterodyne notes should be heard in the phones as this condenser is varied. If this is not the case and the oscillator wiring checks out correctly, the trouble may be found in the coupler itself. On the stator of this coupler there are two windings—one in the plate and one in the grid circuit. This means that there are four leads that are brought from this stator. If one of these leads where it leaves the tube has rubbed against the preceding turn of wire so as to short circuit it, it will prevent the oscillator from functioning. If this is the case, it will be well to remove one turn of wire from this end of this particular coil, bringing it back through the coil form as previously. In fact, there is sufficient leeway left in the coupler to remove one turn from either end of each of the two coils, if necessary, without reducing the wave-length range to any great extent. If after convincing yourself that the coupler wiring is satisfactory, and it still does not oscillate, try varying the “B” battery potentials; also check up the “B” battery voltage and try turning the tube filaments a bit higher, to make sure that they are at the proper operating point. With so many tubes controlled from a single rheostat, there will be no danger in burning out the filaments or injuring the tubes—even if they are turned all the way on for a short time.

Now, suppose you have both the oscillator and intermediate wave amplifier operating properly, turn back the potentiometer arm toward the positive side until the amplifier stops oscillating, and the set should be ready to receive signals.

Other Sources of Trouble

There are several troubles that are sometimes encountered, even after the amplifier and oscillator are performing properly. The most common of these is defective tubes. A bad tube should be suspected above all else, as it is the easiest test to make and occurs quite often. The tube may not be worthless; but its characteristics may be so different from the other tubes used in the circuit that it will not operate satisfactorily with them. And again, a tube which might operate quite satisfactorily as an audio-frequency amplifier or detector might not work properly as an oscillator. Therefore, do not neglect to change tubes when hunting trouble in either the amplifier or oscillator; and also, after the set is operating, change the tubes around until the best possible combination is found. One or two spare tubes are very valuable assets for this purpose.

An infrequent source of trouble is found in the grid condensers and leaks, as either of these is liable to be defective or open-circuited, and occasionally in the case of condensers, short-circuited. Good fixed grid leaks should be used, and, as a general rule, it will be found that a value of about two megohms is satisfactory for the second detector tube and about five megohms for the first detector tube. Do not omit the by-pass condenser from the plate to the negative filament on the last detector tube—otherwise, the set will be unstable and hand capacity will be noticeable.

If the set does not tune sharply, or poor volume is obtained, it can usually be traced to the fixed condenser, across the tuned transformer. These small fixed condensers are bound to vary somewhat in capacity. A small variation in the capacity here will have no bad effect on the operation of the set; but occasionally a condenser is obtained which is so far off as to seriously affect the operation of the circuit.

This can be checked by temporarily placing a .001 variable condenser across the terminals of the intermediate frequency transformer which is tuned. The capacity of the variable condenser should be varied until maximum signal

strength is obtained. If it is necessary to use the entire capacity of the variable condenser then a .001 fixed condenser should be placed in parallel with the condensers and the variable condenser varied again until maximum signal strength is obtained. Thus, it is possible to determine the exact capacity necessary to tune the tuned transformer to exact resonance.

Whenever a potentiometer is inserted in the "B" battery lead it should have connected across its terminal a large fixed condenser so as to by-pass the radio-frequency current. The capacity of this by-pass condenser should not be smaller than .005 mfd. and preferably should be .5 mfd. or larger.

In constructing a Super-Heterodyne, one should not attempt to make the transformers or oscillator, unless he has had considerable experience in radio construction and designing. It is best to buy a complete Super-Heterodyne kit. In addition to the instruction given in the kit, the following may be helpful:

It is best not to use too high plate voltage on the detector tubes and on the oscillator tube. Clearer and sometimes louder signals are obtained by using 45 volts or less. If the oscillator does not work, check over the wiring and be sure that the by-pass condenser from the "B" battery plus to the filament is used. The tubes should be switched around for best results. Oftentimes a tube will work good as an amplifier, but not so good as an oscillator, or detector, or vice versa.

The so-called first detector can be operated as a bias detector or as a detector using the grid leak and condenser method. Experience has proven that the set is slightly more sensitive when using the grid leak and condenser method of detection. However, the loop or antenna tuning sometimes is quite broad when using this method of detection. It has been proven that by using the bias method of detection and using a very large negative bias such as something between -6 and -10 on the grid of the first detector tube the loop or antenna tuning can thus be materially sharpened.

A five megohm grid leak should be used on the first detector and a two megohm on the second detector.

A potentiometer for controlling oscillation of the I. F. tubes should be used in nearly all cases as it is an efficient means of controlling volume and stability.

One rheostat is usually sufficient if the same types of tubes

are used throughout. A two ohm rheostat is used for the 201-A tubes and a six ohm rheostat is used for the 199 type.

Low ratio transformers should be used in the audio amplifier. Any type that has a turn ratio of not more than four to one is satisfactory. If the amplifier howls or wheezes, it may be necessary to reverse the connections on the primaries of the audio transformers. A .0025 mfd. condenser across the primary of the second stage transformer often helps.

In many Super-Heterodynes using two stages of transformer-coupled audio-frequency amplification, the quality is none too good in the last stage. A simple and cheap way to improve this condition is to use impedance-coupled amplification in the last stage. The audio transformer is still used

X
CJ

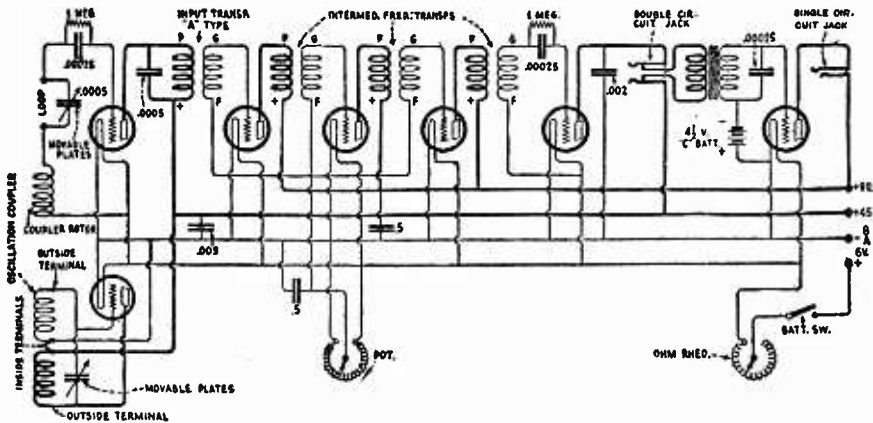

Fig. 12—Circuit Diagram of a Seven-Tube Super-Heterodyne Receiver.

as a choke coil for audio-frequencies. This will greatly improve the audio-frequency signals. Only the secondary of the transformer is used as this has sufficient impedance to prevent the passage of audible frequencies, thereby forcing them on to the grid of the next tube through the blocking condenser.

A grid leak of about one megohm is used on the last tube:

The blocking condenser may be any value large enough to handle the current, about a .006 mfd. is satisfactory.

Short Wave Reception

There are several broadcasting stations experimenting with short wave-lengths in the neighborhood of 100 meters, and it is entirely possible to obtain good reception at these wave-lengths with this outfit, particularly when the above

+
10

method is used to reduce the minimum capacity of the oscillator condenser. To do this, it is merely necessary to provide a tap on the loop, which will allow the two outside turns to be used, that is, only two turns of the loop are across the tuning condenser, the rest being left open. Now if the oscillator is tuned to what is normally the proper point for 200 meter reception, wave-lengths of 100 meters may be received. This is due to the fact that the double frequency harmonic of the oscillator will heterodyne these signals and bring them through the Super in exactly the same manner as when using the fundamental frequency.

TEST QUESTIONS

Number your answer sheet 21 and add your Student Number.

Never hold up one set of lesson answers until you have another set ready to send in. Send each lesson in by itself before you start on the next lesson.

In that way, we will be able to work together much more closely, you'll get more out of your course, and better lesson service.

1. Why is an oscillator used in a Super-Heterodyne Receiver?
2. What is the function of the intermediate wave amplifier?
3. Draw a circuit diagram of an oscillator and frequency changer as used in the Super-Heterodyne.
4. Explain the principle of the Super-Heterodyne Receiver and its advantages.
5. Why are iron core transformers used for radio-frequency amplification in the Super-Heterodyne Set?
6. Draw a circuit diagram of a Super-Heterodyne Receiver using six tubes.
7. What is the principal difference and advantage of using a six tube receiver?
8. Explain what is meant by the second harmonic method of producing the oscillator frequency.
9. How can the quality of the audio-frequency signals be improved?
10. What changes would you make in this type of set for reception of short wave-lengths?

X

