

NATIONAL RADIO INSTITUTE

Complete Course in
PRACTICAL RADIO



Radio-Trician

(Trade Mark Registered U. S. Patent Office.)

LESSON TEXT No. 11

(2nd Edition)

THE
VACUUM TUBE
AS AN
AMPLIFIER

Originators of Radio Home Study Courses
... Established 1914 ...
Washington, D. C.

"You are just as big as the things you do, just as small as the things you leave undone. The size of your life is the scale of your thinking."

—Woodrow Wilson.

SOME GOOD STUDY HABITS

A Personal Message from J. E. Smith

Clearness. The habit of insisting on clearness of thought is essential to study. Mental vagueness is mental weakness. Never leave a lesson with a vague idea of it. A good way to overcome mental cloudiness is to establish the habit of writing out the vague points. If you can express your thoughts in writing, it will help you clear them up.

Copyright 1929, 1930
by
NATIONAL RADIO INSTITUTE
Washington, D. C.

Radio-Trician's

(Trade Mark Registered U. S. Patent Office.)

Complete Course in Practical Radio

NATIONAL RADIO INSTITUTE

WASHINGTON, D. C.

THE VACUUM TUBE AS AN AMPLIFIER

Thus far in the study of "Practical Radio", our study of elementary principles has built a foundation preparing us to take up one of the most important subjects connected with Radio—the action of a three element vacuum tube as an amplifier. In the previous lesson, the action of the vacuum tube as a detector was studied. In this lesson, *the action of the three element vacuum tube as an amplifier will be discussed.* Without this adaption, the usefulness of the vacuum tube in radio would be confined to detection or rectification.

Before proceeding with a detailed study of the action of a vacuum tube as an amplifier, let us briefly review some facts. To understand the action of a vacuum tube, the following facts should be borne in mind. A current of electricity is simply a flow of electrons, the electrons flowing in one direction, which makes a current. Electrons are small charges of negative electricity. All material contains electrons. There are two kinds of electricity—positive and negative. Like electricity repels and unlike attracts.

The following additional facts must now be grasped before the action of the vacuum tube can be thoroughly understood. It has been discovered that metals, if heated, will throw off into space some of the electrons which the metals contain. Furthermore it has been discovered that the hotter the metal, up to a certain degree of heat, the more electrons it discharges. These electrons travel at a high rate of speed. If air or any other gas be present in the space around the metal, the electrons strike the minute particles of the air or gas and are soon stopped.

At this point, it would be well to bring out a point in regard to the direction of flow of current and the direction of flow of electrons. The direction in which electric current is said to flow is a matter of arbitrary decision. The electric current is said to flow from positive to negative in the exterior part of a battery circuit. When the early scientists decided which

way the electric current flowed, they did not have knowledge of the existence of electrons so they called one terminal of a battery positive and the other negative, and since the positive value indicates a stronger force than a negative value, the current was said to flow from positive to negative. Since that day, the electron theory has been definitely established. It has been definitely established that the electrons flow from the negative terminal of a battery to the positive terminal in the exterior part of the battery circuit. The student should firmly bear this in mind and not become confused as to the direction of flow of electrons because this is definitely settled. To prevent any seeming contradiction we shall adhere to

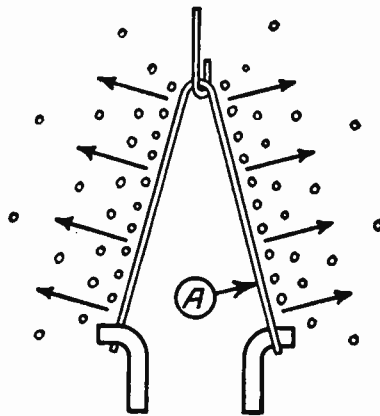

Fig. 1—The Electron Discharge from the Ordinary Filament. The arrows on this much-simplified drawing show the direction taken by the electrons that are emitted from the heated tungsten filament, A.

the popular way of expressing the direction of flow of current—that is, from the *positive to the negative* in the exterior part of a battery circuit.

THE FILAMENT

There are at present *three general types of materials used in the construction of the filament: tungsten wire filament, the oxide coated tungsten filament and the thorium coated tungsten filament.* Formerly, all vacuum tubes used the tungsten type of filament. It was later discovered that by coating the tungsten filament with the oxide of certain metals that the number of electrons given off by the filament for a certain amount of cur-

rent passing through the filament would be materially increased.

For a given number of electrons thrown off, less current would be required to heat the filament naturally, the filament could be operated at a much lower temperature, with a considerable increase in the life of the filament, before burning out. The latest advance in filament construction consists in coating the tungsten filament with thorium. This gives a further increase of electron emission, and in order to have a certain amount of electron emission, a further saving in the amount of current required to heat the filament is obtained.

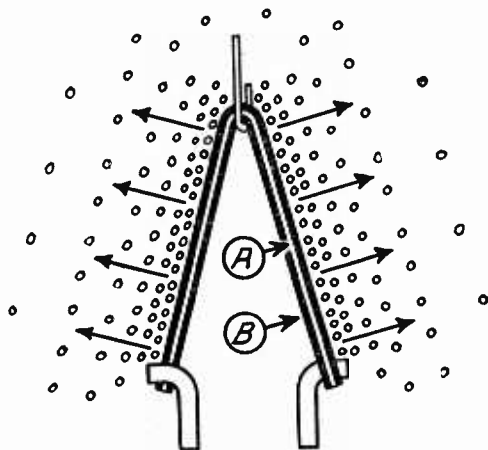

Fig. 2—The Electron Discharge from the Thoriated Filament. Note the greatly increased emission of electrons from the tungsten filament, A, which has been coated with a minute layer of thorium, B.

This is illustrated in Figures 1 and 2. In Figure 1, it will be noticed that the number of electrons, represented by the small circle, is not nearly as great as the electrons represented in Figure 2.

ACTION OF THE VACUUM TUBE

A vacuum tube consists of a container, usually glass, from which the air has been pumped. In this glass tube or bulb is mounted the filament, the grid, and the plate. In some A. C. tubes the usual filament is replaced by an indirectly heated cathode consisting of a metal oxide coated cylinder; this throws off the electrons as it is heated by an internal filament.

By applying some facts previously learned, we can now take up in detail and understand the action of the vacuum tube. Since the air is pumped from the glass tube or bulb (hence

the name vacuum), the passage of the electrons thrown off from the filament will not be stopped. Since there is only a very small amount of air or gas within the glass tube, electrons thrown off by the filament will be accelerated, because there are no small air particles which impede the electrons in becoming detached from the filament.

In Fig. 3, the filament is heated so that it becomes red or white hot. This is done by the electric current furnished by the "A" battery or by a step-down transformer with AC tubes. Suppose that the filament is hot and the grid and plate are not connected to outside circuits. The electrons are thrown off from the filament and strike both the grid and the plate. These acquire a negative charge, as they have

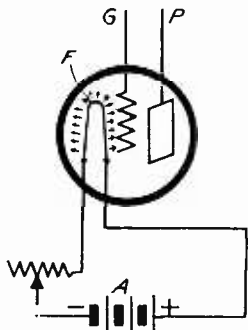

Fig. 3

acquired electrons, which are negative charges of electricity. The space inside the tube has also a negative charge as the space is filled with negative electrons. Like charges repel each other and hence the negative charge on the plate, the negative charge on the grid, and the negatively charged space inside the tube are all repelling the electrons which the hot filament is trying to throw off. As each electron is thrown off of the filament, it adds its charge, either to the plate, grid, or space. The stronger charge

causes a stronger repulsion of the escaping electron. In a very short while, the repulsion is strong enough to prevent the escape of any more electrons from the filament.

Figure 4 shows an "A" battery, used to heat the filament and a "B" battery, with its positive terminal connected to the plate of the tube, and its negative terminal connected to the filament circuit. (The use of the grid will be shown later). By connecting the battery as shown in the figure, two things have been done. First, a positive potential has been placed on the plate; second, a metallic circuit containing a battery has been made outside of the tube from the plate to the filament. This leaves only the space between the filament and the plate inside the tube to complete the circuit. The "A" battery is used simply to heat the filament.

The heated filament throws off electrons. *The plate is positive and attracts the electrons which are negative.* The

electrons travel through the space (no air or gas particles being present to hinder them as it is a vacuum) from the filament to the plate. There is then a flow of electrons from the filament to the plate and a flow of electrons is an electric current. Thus, the combination of the heated filament, the vacuum, and the positively charged plate, has caused a current to flow; that is, in effect, it has completed the circuit which contains the "B" battery, plate and filament.

The action of the "B" battery is comparable to a pump. When it forms part of a circuit, it pumps electrons out of its negative terminal and into its positive terminal. In the circuit arrangement shown in Fig. 4, the "B" battery pumps the

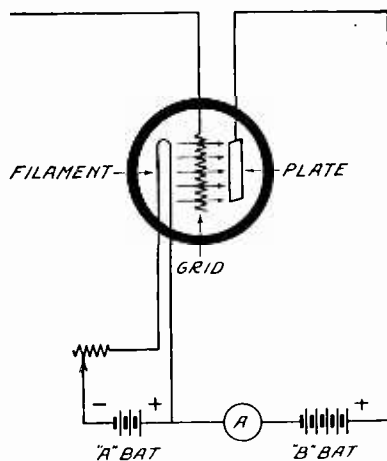

Fig. 4—Diagram of the Insulated Grid in the Vacuum Tube.

electrons coming from the filament, to the plate to the + terminal of the "B" battery and out of the — terminal of the "B" battery to the filament. The filament again throws them off and they go to the plate, being attracted by it as it is positive and the electrons flow around the circuit. This flow of electrons constituting a current of electricity can be measured by the ammeter, A, placed as shown. This ammeter could also be placed between the plate and the positive terminal of the "B" battery.

Consider the effect of changing the number of cells in the "B" battery. Changing the number of cells in the battery would change the positive potential on the plate. If the positive potential on the plate became greater, it would have a greater attraction for the flying electrons in the tube, and hence in a given

time, more electrons would arrive at the plate and be pumped around the circuit by the "B" battery. An increased flow of electrons means an increased flow of current. In the same way, a decreased potential on the plate would cause a smaller current to flow. This change in current with a change in plate potential does not follow Ohm's Law; that is, doubling the plate potential does not double the current as it does in a wholly metallic circuit. If there is not an increase in filament current and temperature, only a certain amount of electrons can be thrown off by the filament, and hence a point will be reached when the plate potential is raised, where no more electrons can be attracted from the filament to the plate.

Since the electric current is said to flow in the opposite direction from the electrons, this electric current is then said to flow from the positive terminal of the "B" battery, through the plate, and then by means of the electron current, through the filament, and back to the negative terminal of the "B" battery. The electrons pass from the filament to the plate and grid. Neither the plate nor grid can emit electrons as they are not heated. This means that the electrons can pass only one way through the tube; an electric current can pass only one way through the tube. This is exactly what the crystal detector does. A vacuum tube with only a filament and plate (grid connected to the plate or not built into the tube) may be used as a detector in place of the crystal. Such a tube may also be used as a rectifier of alternating currents, because it allows current to pass only in one direction. Now we will explain how the grid greatly improves the action of the tube, before taking up the action of the vacuum tube as an amplifier.

ACTION OF THE GRID

As has been explained, the plate current may be controlled by variation of the filament current and temperature and also by variation of the plate potential. It was discovered by DeForest that putting a third element in the tube gives a more sensitive method of control. This third element is the grid. It must be remembered that the grid is a lattice-like construction which surrounds the filament and is, therefore, between the filament and the plate.

The illustrations so far do not show any connection to the grid. The electrons, which are emitted by the filament, pass through and around this grid and are not impeded in

their passage to the plate. Now, suppose we should connect a small battery (shown as "C" in Fig. 5) across the filament and grid with the negative terminal connected to the grid and the positive terminal connected to the filament. This would make the grid negative with respect to the filament, or in other words, a negative charge will be placed on the grid. Let us study the effect of this charge on the grid in the diagram. The electrons trying to leave the filament represented by the arrows are negative. The grid is charged negatively by the "C" battery. Remembering the fact that "*like charges repel and unlike charges attract,*" we readily see that the electrons are repelled and forced back to the filament; a small number, or

2x

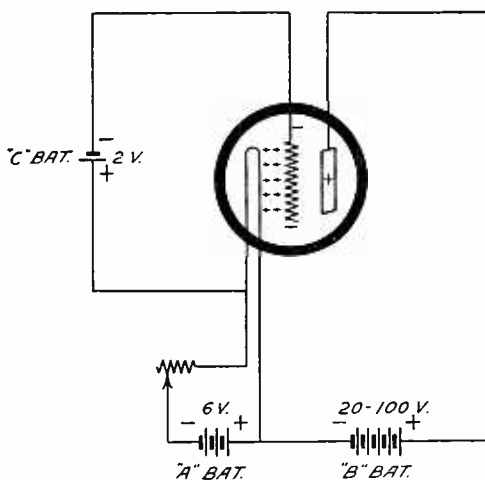

Fig. 5—This Diagram Illustrates the Action of the Negative Charge on the Grid.

none, ever get across to the plate. Hence, in this connection, the tube lets little or no current across from the plate to the filament.

2x

What would happen if we suddenly were to reverse the terminals of the "C" battery which is charging the grid? Let us investigate this in Fig. 6. In this case, the grid would have a positive charge and the negative electrons would be strongly attracted across from the filament to the grid. When they get this far on their journey, they begin to feel the greater attraction of the higher positive voltage charge on the plate and they pass through the spaces in the grid in a flying effort to get to the plate, which receives them "with open arms", so to speak.

The attraction of the positive charge on the grid draws many times more electrons from the filament than would ordinarily leave it, and thus the density of the stream is increased many times. The current flowing across from the plate to the filament, of course, is a direct current, and is known as the plate current of the tube. To sum up the action of the tube in a few words, we might say that the plate current of the vacuum tube can be controlled by the voltages applied to the grid.

In Figures 5 and 6, the "C" battery allows a potential to be placed on the grid. This can be made stronger or weaker by changing the potential of the battery. It can be made positive or negative by reversing the connection of the battery. *Making the positive potential of the grid higher causes it to attract the electrons with more force, and causes a greater current*

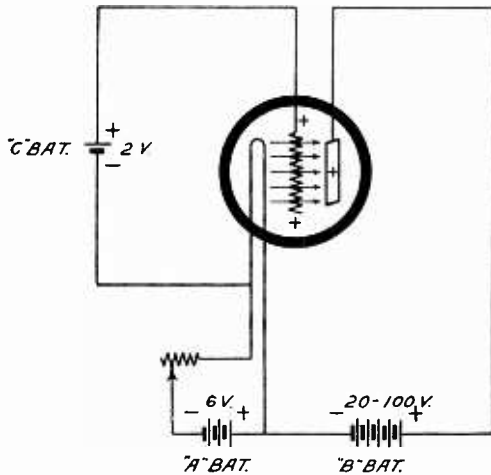

Fig. 6—The Action of the Positive Charge on the Grid.

to flow in the tube. By making the negative potential of the grid higher, the electrons are impeded in their progress, resulting in a decreased amount reaching the plate and a corresponding decrease in the plate current. Since the grid itself has a very small surface and does not catch many of the flying electrons, most of the electrons go past the grid and reach the plate when there is a positive potential on the grid. If the negative potential is made large enough, its repulsion of the electrons will entirely stop their flow and hence stop the passage of any plate current. Because of the nearness of the grid to the filament, a slight change in the potential of the grid

makes a large change in the plate current. The effect of changing the grid potential is, therefore, much greater than obtained by changing the plate potential. Thus, it is possible to have a small amount of energy acting on the grid control a greater amount of energy in the plate circuit.

In Figure 7, we have an arrangement whereby it is possible to quickly vary the amount of voltage and the polarity of the voltage that is applied to the grid. When the movable arm of the potentiometer, P, is at C, there will be a negative potential applied to the grid, equal to the potential difference between the points A and C. When the arm is at B, a positive potential will be applied to the grid. Since the grid-return, filament end of the grid connection or circuit, connects to the filament, at point A, which corresponds to the middle cell of the "C" battery, the grid voltmeter will not indicate any potential difference between the grid and filament when the arm of the

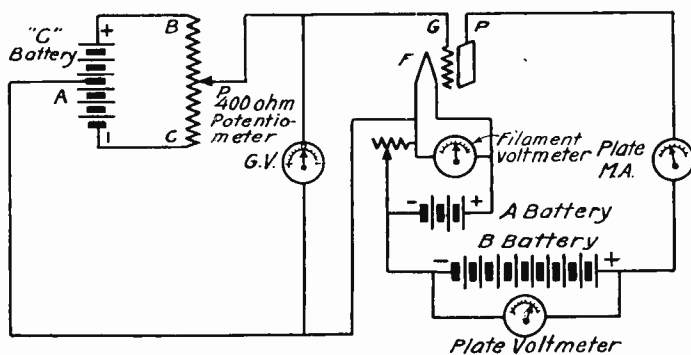

Fig. 7—Circuit Diagram of Testing Set for Obtaining Tube Characteristics.

potentiometer is half-way between C and B. The opposite voltages between AB and AC just balance each other.

As the potentiometer arm is moved along the resistance, the voltage applied to the grid, which is usually called bias voltage, causes a change in the plate current as registered by the plate milliammeter. By changing the applied grid or bias voltage, the plate current is changed. Suppose that no current is flowing in the plate circuit when the potentiometer arm is at C in Fig. 7 and when the arm is at B, a flow of 6 milliamperes. At intermediate points between C and B, the grid voltmeter and plate milliammeter reading could be recorded for future reference. The readings could be recorded something like that shown in Table No. I.

In the left-hand column, the grid voltages are shown and on the same line in the right hand column, the corresponding plate current is shown.

Different tubes of the same type, or different types of tubes will give different readings. Later on in this lesson, we are going to make use of this table and the figures therein in order to learn more about the action of the vacuum tube.

So far in our study of the action of the vacuum tube, we have found that with a negative potential applied to the grid, the electrons passing between the filament and plate are retarded, resulting in a decrease of plate current. Furthermore, with a positive potential applied, we found that this positive potential assisted the plate in attracting the negative electrons, resulting in an increase of plate current. However, we overlooked an important fact. In Figure 6 when the positive terminal of the "C" battery is connected to the grid with a positive charge applied to the grid, it can be noted that a few

TABLE No. I

Grid Volts	Plate Current Milliamperes	Grid Volts	Plate Current Milliamperes
-13.5	0.0	+ 1.5	3.5
-12.	.1	+ 3.	4.0
-10.5	.18	+ 4.5	4.5
- 9.	.25	+ 6.	5.0
- 7.5	.5	+ 7.5	5.45
- 6.	1.	+ 9.	5.7
- 4.5	1.5	+10.5	5.8
- 3.	2.	+12.	5.9
- 1.5	2.5	+13.5	6.00
0	3.		

of the electrons will be stopped by the grid, and since the "C" battery positive is connected to the grid, these electrons will pass from the grid to the positive terminal "C" battery, and thence to the filament, completing a circuit. This results in a very few of the electrons which should go to the plate being utilized in the grid circuit. If there were only a certain number of electrons being given off by the filament and some were utilized in the grid circuit, when the grid becomes positive, then, this would result in less electrons reaching the plate and a very slight reduction in the plate current. This, we want to overcome because when the grid is positive with respect to the filament, the plate current will be increased in the same

amount that the plate current is decreased when a negative potential having the same value as the positive potential is applied to the grid.

Before proceeding further, it will be well to clear up another statement for the student. When the grid is spoken of as being positive, or negative, with respect to the filament, the negative end of the filament is referred to as this is the end which the electrons enter in their passage through the filament from the "A" battery. Remember this, as it is a very simple but important fact. X

We have not yet settled our problem of preventing a current from flowing in the grid circuit when the grid is positive with respect to the filament. How can we arrange things when the grid becomes positive with respect to the filament, a grid current will not flow? Simple enough, but read these next few sentences carefully. We found that when the grid was slightly negative that the grid repelled some of the electrons and prevented them from reaching the plate, resulting in a very slight decrease in plate current. The more the grid became negative, the more the plate current was decreased until finally the plate current could be cut off entirely. However, it is not desirable to do this. Suppose that the grid is permanently maintained at some negative value so that any changes in the potential applied to the grid never allow the grid to become positive with respect to the filament. To make this point clearer, let us say that we apply a negative potential of two volts to the grid. If the negative grid potential is increased one volt more or to three volts, we would have less plate current flowing than when two volts negative were applied. Also, if the negative grid potential is decreased from two volts to one volt negative, there would be more plate current flowing than when two volts negative were applied to the grid. X

Now refer to Fig. 8. Here we have an alternating current generator, G, connected to the grid and filament of a vacuum tube. A cell, C, which delivers, let us say, two volts, is inserted in series in the grid connecting wire. Notice that the negative terminal of the cell, C, is connected to the grid of the tube. As in the case given in the preceding paragraph, let us say the generator delivers one volt of alternating current. When the voltage of the generator is trying to force current from A in the direction of C and to the grid, it is opposed by the voltage of the cell, C, which is trying to force current

in the opposite direction. When the voltage of the generator is trying to force current from B in the direction of the filament, it is assisted by the cell, C. As the cell, C, delivers more voltage than the generator, then the grid is always negative with respect to the filament. The voltage of the generator merely adds to and subtracts from the effective voltage of the cell which is applied to the grid. Here, then, is the solution of our problem. By always keeping a negative potential applied to the grid, the grid never becomes positive in respect to the filament, whenever changes in potential occur. Changes in the grid potential will cause corresponding changes in the plate current.

In Figure 8, the alternating current generator causes the voltage applied to the grid to vary between minus one and minus three volts. Since the normal negative voltage of the

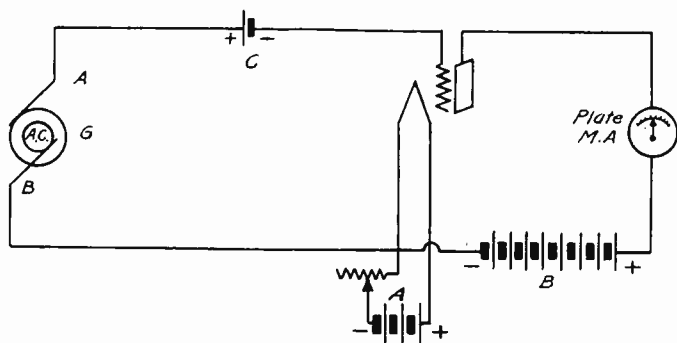

Fig. 8

cell, C, is decreased and increased by the action of the generator voltage, the voltage that is actually applied to the grid is said to vary or swing in a negative and positive direction with respect to its normal voltage. This being the case, we come to an important fact. When a three element vacuum tube is used as an amplifier, the grid must always be maintained at such a negative potential that any variance of this potential will never allow the grid to become positive with respect to the filament. This for the purpose of preventing grid current from flowing. Later we shall learn more about how this is done in a receiving set.

THE CHARACTERISTIC CURVE

Here we have a drawing of a curve on a piece of cross-section paper from which we are going to make use of the

reading of the grid voltage and corresponding plate current readings which were shown in Table No. I. The base line CB corresponds to the voltage that is applied to the grid by moving the potentiometer arm along CB in Fig. 7. We found that as the arm was moved toward B, the plate current increased, so we let the line CD of Fig. 9 represent this increase.

From Table No. I, we found that with the arm at C or the maximum negative voltage, we did not have any plate current flowing. Now in order to make these values serve another purpose, we will plot them on the sheet of cross-section paper.

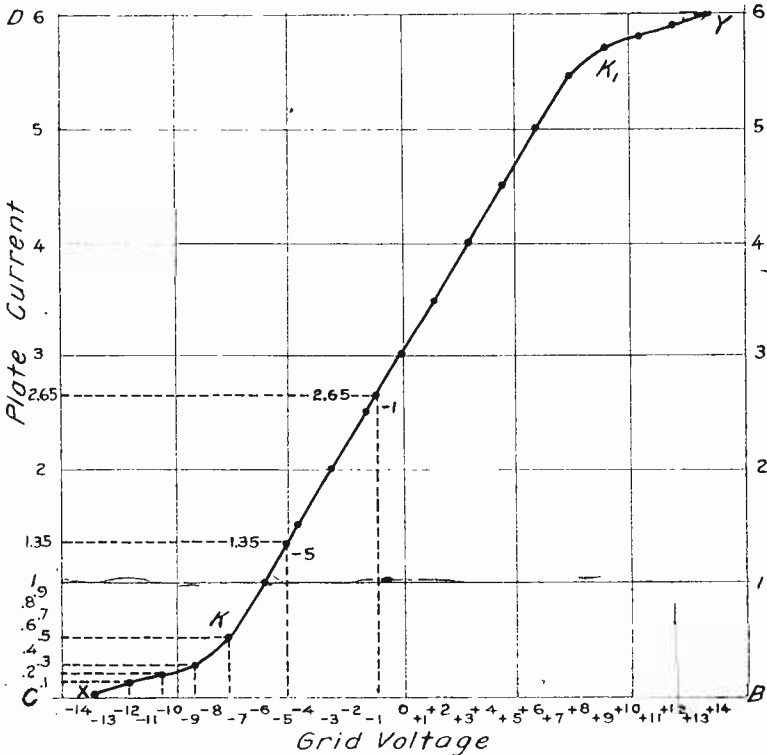

Fig. 9

Locate -12 on the base line CB and go up on this line until the horizontal line opposite for .1 on CD is intersected. This is the first horizontal line above the base line. Stop here and make a dot as shown in Fig. 9. The horizontal lines, represent values of plate current and the vertical lines grid voltages. Now locate the remaining points as obtained from the values given in Table No. I. When all the points have been

located, draw a line connecting all the points and the curve XY is the result.

This is called a characteristic curve of the plate current and grid voltage. It is obtained as just explained. First, it is necessary to have a circuit arranged such as in Fig. 7; then, make note of the values such as in Table No. 1, and finally, plot the curve as shown in Fig. 9.

The important point about this curve is that it is not a straight line. The lower portion of the curve to the left of and above and corresponding to -7.5 grid volts is more horizontal and not as steep as above and corresponding to zero grid volts. Also, again, above and corresponding to $+10$ grid volts, it is more nearly horizontal than between -7.5 and $+7.5$ grid volts.

In our study of detection, in the previous lesson, we found that the tube operates on one of the bends or "knees" of the curve, such as at K or K1, when using the "C" battery method of detection. Should we desire to operate the tube as an amplifier, it is necessary to operate it on the straight portion somewhere between these points.

Why and how do we do this? First, we learned earlier in this lesson that when a vacuum tube was worked as an amplifier, we wanted changes in the grid potential to cause corresponding changes in the plate current. If the grid voltage is increased and decreased in a like amount, we want the plate current to increase and decrease in the same manner. Next, we learned that it was necessary to keep the grid at a permanent negative value in order to prevent a grid current from flowing which would interfere with the plate current increasing in the same proportion that it was decreased for various changes of the grid voltage.

By referring to Fig. 9, we see that between K and K1, the line is almost straight. At the point on curve above and corresponding to -3 grid volts, the tube could be satisfactorily operated as an amplifier. If the grid bias negative voltage is decreased to -1 volt, the plate current would be increased from 2 milliamperes to 2.65 milliamperes. If the negative grid voltage is increased to -5 volts, the plate current would be decreased from 2 to 1.35 milliamperes. We then have the condition under which an amplifier must operate; the grid is maintained at such a negative voltage that any changes which might occur in this potential will never allow it to become positive

TABLE No. 2
AVERAGE CHARACTERISTICS OF RECEIVING TUBES

TUBE	DETECTOR				AMPLIFIER					
	Filament Terminal Volts	Filament Current (Amps.)	"B" Volts	Plate Current (Ma.)	Plate Volts	Grid Bias Volts	Plate Current (Ma.)	Voltage Amplification Factor	Max. Undistorted Output (M ² /w ²)	
CX-12 UX-12	1.1	.25	22.5 to 45 V	1.5	90.0	4.5	2.5	6.6	7	
					135.0	10.5	3.5	6.6	35	
CX-299 UX-199	3.3	.063	22.5 to 45 V	1.5	45.0	1.5	1.0	6.6		
					67.5	3.0	1.7	6.6		
CX-220 UX-120	3.3	.132			90.0	4.5	2.5	6.6	7	
					135.0	16.5	3.2	3.3		
CX-322 UX-222	3.3	.132	Screen-Grid Voltage + 45		90.0	1.5	1.4	175		
					135.0	22.5	6.5	3.3	110	
CX-300A UX-200A	5.0	.25	45	1.5	90.0	1.5	1.0	300		
					135.0	3.0	1.0	300		
CX-301A UX-201A	5.0	.25	45	1.5	45.0	1.5	.9	8.0		
					67.5	3.0	1.7	8.0		
CX-340 UX-240	5.0	.25	135 180	.3 .4	135.0	1.5	.2	30.	*	
					180.0	3.0	.2	30.	*	
CX-326 UX-226	1.5	1.05			90.0	6.0	3.7	8.2	20	
					135.0	9.0	6.0	8.2	70	
C-327 UX-227	2.5	1.75	45	2.0	180.0	13.5	7.5	8.2	160	
					90.0	6.0	3.0	9.0		
C-324 UX-224	2.5	1.75	Screen-Grid Voltage + 75		135.0	9.0	5.0	9.0		
					180.0	13.5	6.0	9.0		
CX-112A UX-112A	5.0	.25				D. C.	A. C.			
					90.0	4.5	7.0	5.5	8.0	30
					135.0	9.0	11.5	7.0	8.0	120
					157.5	10.5	13.0	9.5	8.0	195
CX-371A UX-171A	5.0	.25			180.0	13.5	16.0	9.5	8.0	300
					90.0	16.5	19.0	10.0	3.0	130
					135.0	27.0	29.5	16.0	3.0	330
					157.5	33.0	35.5	18.0	3.0	500
CX-310 UX-210	7.5	1.25			180.0	40.5	43.0	20.0	3.0	700
					250	18.0	22.0	10.0	8.0	340
					350	27.0	31.0	16.0	8.0	925
					425	35.0	39.0	18.0	8.0	1540
CX-345 UX-245	2.5	1.5			180	33.0	26.0	3.5	780	
					250	50.0	32.0	3.5	1600	
CX-350 UX-250	7.5	1.25			250	45.0	28.0	3.8	900	
					300	54.0	35.0	3.8	1500	
					350	63.0	45.0	3.8	2350	
					400	70.0	55.0	3.8	3250	
					450	84.0	55.0	3.8	4650	

*When used in resistance-coupled amplifier with .25 megohm plate resistor.

with respect to the filament. By applying this negative potential and operating the tube upon the straight portion of its characteristic curve, the changes in grid voltage produce corresponding changes in the plate current.

It will be well to note here that it is not necessary to have a circuit such as shown in Fig. 7 and plot a curve such as shown in Fig. 9 before we can use a particular tube as an amplifier in a receiving set. The manufacturer does all this for us in the laboratory and tells us just what grid voltage to apply for a certain plate voltage. This information is usually given in the sheet of directions which accompanies the tube when it is bought, or else given in a tube chart. Such a tube chart is shown in Table No. 2. Take for instance the UX-201-A tube. Under the column "Amplifier Plate Voltage," we find the figures 90; under the column for "Amplifier Grid Bias Voltage," the figures 4.5. When a plate voltage of 90 volts is applied to the tube, a negative voltage of 4.5 volts should be applied to the grid, and for 135 volts on the plate, 9 volts negative should be applied to the grid. By applying the proper negative grid voltage to the tube, when a certain plate voltage is applied, the tube is caused to work upon the straight part of its characteristic curve where proper amplification takes place.

ACTUAL WORKING CONDITIONS

Now let us refer to Fig. 11. Here we have the circuit diagram of part of a receiving set. The approaching signal wave which is sent out by the transmitting set strikes the antenna, induces a voltage in it, and causes a current to pass through the coil L to the ground. The current in passing through the coil L sets up a magnetic field which changes according to the changing signal voltage in the antenna. This changing field induces a voltage in the coil L2. The variable condenser C connected across the coil L2 tunes or causes the circuit L2 C to be responsive to the same frequency as the signal voltage induced in the antenna. There is then a corresponding alternating voltage in the circuit L2 C and since one terminal of the coil L2 and the condenser C connects to the grid, and the other terminal of the coil L2 and condenser C connects to the negative terminal of the "C" battery and then to the filament, this alternating voltage causes changes in the applied potential between the grid and filament. Any change in the grid potential will cause changes in the plate current,

therefore, the amplifier tube V.T. merely repeats the changes of the grid potential in the plate circuit. As the "C" battery always maintains the grid at a negative potential, as previously explained in regard to Fig. 8, the plate current rises and falls in proportion to the changes in the grid voltage.

There are two important things to remember here. First, the antenna signal current, which flows through L merely induces a voltage in the secondary circuit L₂ C and this in turn is impressed on the grid, resulting in a change in plate current. The antenna current does not flow through the secondary circuit and then through the tube and plate circuit. In flowing through the primary coil L, a voltage is induced in L₂ C circuit which affects the grid potential resulting in a change in plate current. Each part of the circuit "repeats" the changing currents and voltages.

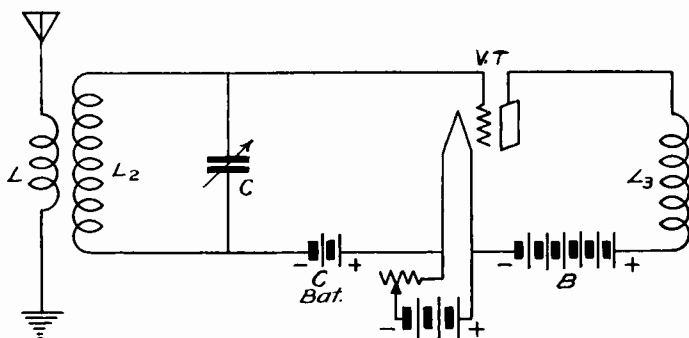

Fig. 11

The *second* point is that the vacuum tube amplifier V.T. is a voltage actuated device. By this, we mean that what we desire is to have a change in the potential that is applied to the grid. The "C" battery maintains the grid at a certain negative potential when there is no signal voltage on the antenna. When a wave approaches, the net result is that the effective voltage of this "C" battery is changed, resulting in a changed grid potential and a corresponding change in plate current. Thus, it can be seen that the change in plate current depends upon a change in the voltage applied to the grid.

It is not always necessary to use a "C" battery in order to maintain the grid at a slight negative potential or bias. This negative bias can be obtained in another way, illustrated in Fig. 12. Notice that the "C" battery is left out, and the grid-return connects to the negative terminal of the "A" battery.

Previously, it was stated that when the grid was spoken of as being negative or positive in respect to the filament that the negative end of the filament was referred to. Since this is true and the grid-return in Fig. 12 connects directly to the negative terminal of the "A" battery, then the grid is slightly negative with respect to the negative end of the filament. This is true due to the voltage drop in the filament rheostat.

The main point to remember about the amount of negative "C" battery or bias voltage is that it must always be greater than the signal or alternating voltage that is applied between the grid and filament in order to prevent a grid current from flowing.

FORM OF PLATE CURRENT

Earlier in this lesson, we learned that the plate was maintained at a positive potential by being connected to the positive terminal of the plate or "B" battery in order to attract the electrons thrown off by the filament. *The electrons flow in one direction only, from the filament to the plate.* Therefore, any change in the grid potential merely causes a rising and falling of the plate current. The plate current never reverses its direction of flow.

Some writers refer to the plate current as "alternating". This is misleading to the student, as the word alternating indicates a reversal in direction of flow. A better way is to say "the alternating component of the plate current".

This varying or alternating component of the plate current comes in due to the fact that when a vacuum tube is properly used as an amplifier, the form of the plate current resembles the form of the alternating voltage applied to the grid.

By referring to Fig. 13, this can be more easily understood. In this figure, we have illustrated a characteristic curve of a tube. The grid is maintained at a negative value of 3 volts. This is shown as the point B on the curve. This point also represents the steady plate current of 2 milliamperes flowing. Suppose that while the grid is maintained at this potential, we impress on the grid an alternating voltage causing its potential to vary between minus 1 and minus 5 volts. In order to illustrate the changing values in grid voltage and corresponding changes in plate current, the "wavy" curves E_g and I_p have been used. Since the letter E usually represents volts, then to indicate grid voltage, the letter g is added. The letter I is

used to represent current, hence I_p represents plate current. As the grid negative voltage is decreased from -3 to -1 volts caused by the applied alternating voltage, then the part of the wave or curve from B to D represents this change. The effect of decreasing the negative grid voltage results in an increase of plate current as shown by the part of the plate current curve from B to E. As the effective grid voltage begins to increase, due to the applied alternating grid voltage, it reaches its maximum negative value at A, so that the part of the curve or wave from D to F represents this change. Due to this increase in negative grid potential, the plate current decreases from E to G. By carrying this explanation further, the balance of the grid voltage and plate current curves are completed.

The main point to note about these curves is that the plate current curve I_p is larger than the grid voltage curve E_g , and

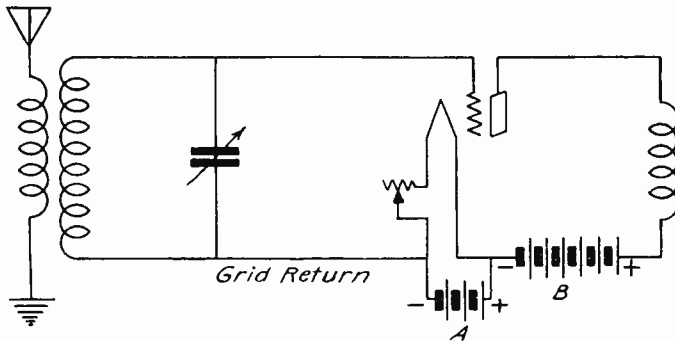

Fig. 12

that it also is the same general shape. Since this varying plate current has the same shape as the curve E_g representing the alternating grid voltage, it is common to speak of the varying plate current as “alternating”, or better yet, “the alternating component of the plate current”.

AMPLIFICATION FACTOR

The amplification factor of a vacuum tube is its theoretical voltage amplifying power. The symbol μ used in representing this amplification constant is known as “mu” which resembles our small letter “ μ ” as used in the alphabet. The amplification factor of a tube depends, for example, on the mesh of the grid, diameter of the grid wire, and resistance between the grid and the plate. In practice, it is generally found that the amplification constant does not vary. For extreme limits of grid voltage and plate voltage, this constant does change

+
5

slightly. The voltage amplification factor or amplification factor, as it is usually called, is generally given in the direction sheets which accompany a tube and in tube charts, such as in charts shown in Table No. 2. As a practical example, suppose the amplification factor of a certain tube is given as 8 as determined by examining Table No. 2. This simply means that whenever a grid voltage is applied to the grid-filament

4
5

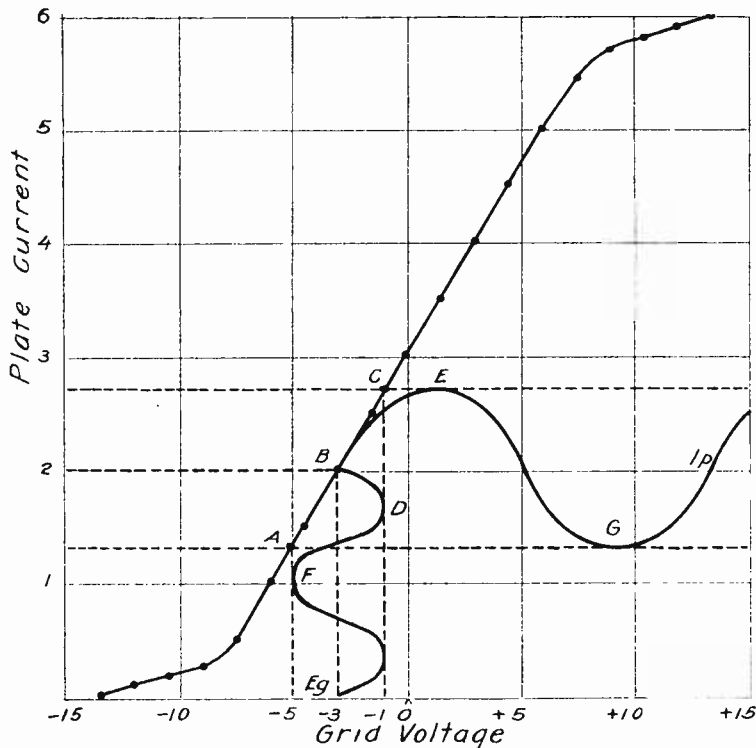

Fig. 13

circuit, it is increased eight times in the plate circuit. The amplifying power of the tube is eight times. This amplification factor is regarded as the constant because it cannot be changed by altering any of the circuit arrangements or parts within the circuit. It depends upon the geometrical arrangement of the elements within the tube.

SPACE CHARGE

In Fig. 14 is shown in elementary fashion the distribution of electrons between the plate and the filament; we will

consider the electric forces acting on two of the electrons A and B. The electron A is urged to the plate by two forces, the attraction from the plate and the repulsion from all of the electrons between it and the filament; it will undoubtedly go to the plate. Electron B, although attracted by the plate, is repelled by all the electrons between the plate and itself; whether it will move towards the plate or re-enter the filament depends upon the relation between these two forces. It is evident that close to the surface of the filament, the effect of all the electrons in the space between the filament and the plate (constituting the space charge) will practically neutralize any effect on the plate, unless the

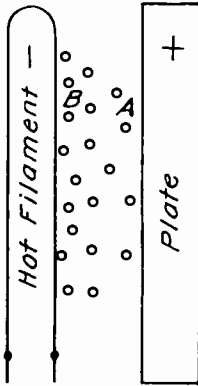

Fig. 14

the plate voltage is high enough to give a force of attraction greater than the repulsion force exerted by the space charge. Thus, it can be seen that it is necessary to use a high voltage applied to the plate of the tube in order to overcome this space charge effect which causes the electrons near the filament to be repelled to a certain extent. As the electrons progress in their travel from the filament to the plate, they are naturally accelerated due to the attraction of the plate and due to the fact that the electrons which have overcome the space charge assist them.

PLATE RESISTANCE AND IMPEDANCE

The plate resistance of a tube is due to the work which the electrons emitted from the cathode (filament) must perform in moving from the cathode to the anode (plate). Let us consider the case of a single electron emitted from the cathode. In moving through the cathode surface, it has to do an amount of work equivalent to the electron affinity, and in moving from the cathode to the anode, it has to do work in overcoming the space charge effect and difference in potential between the cathode and anode. This may sometimes assist the electrons in moving from cathode to anode. If these were the only forces exerted on a large number of electrons escaping from the cathode, the application of a small voltage between cathode and anode would almost immediately give rise to the saturation current (total amount of plate current obtainable) and the resistance of the tube would be very low for all values of cur-

rent less than the saturation current. This is not the case, since the electrons in the space exert a mutual repelling force on one another. This is the space charge effect previously explained and causes by far the greatest expenditure of energy on the part of the electrons in moving to the anode. This expenditure of energy causes a slight heating of the anode. In small receiving tubes, this heating of the anode never becomes enough to be visible unless excessive voltages are applied to the anode.

The true direct current resistance of the tube is, of course, given simply by the ratio of the total amount of work done to the square of the current, that is, by the ratio of the plate voltage to the plate current. The alternating current resistance, on the other hand, is given by the slope of the plate current characteristic curve, and since the characteristic curve is non-linear, the alternating current and direct current resistances are not the same. The impedance (alternating current resistance) of the tube is given by the ratio of the alternating voltage acting between the filament and the plate, to the alternating current component in the plate circuit.



CASCADE AMPLIFICATION

From our discussion so far, we have learned that the vacuum tube amplifier merely increases and repeats changes in voltage applied to the grid in the plate circuit. The real advantage of the vacuum tube as an amplifier is due to the fact that several amplifier circuits or stages can be properly connected, one following the other, and the original signal voltage repeated and amplified many times. Where several stages of amplification are to be used, it is commonly referred to as cascade amplification.

+
6

If oscillations (alternating current of high-frequency) are applied to the grid of one tube, we have learned that this creates variations in the plate current. If the plate current of this tube passes through the primary coil of a suitable transformer, then variations of current through it create corresponding changes of potential at the terminals of the secondary circuit of the transformer (see Fig. 15).

We can apply this amplified potential to affect the grid of a second tube, and again couple the transformer of the second tube to the grid of a third tube and so on. The great importance of this cascade arrangement is that the resultant ampli-

fication of the stages is the product, and not merely the sum, of their separate amplification. Now, suppose each tube and its transformer amplifies the potential variations ten times, then two in series or cascade, amplify 100 times, and three, 1,000 times and so on. Hence, by the use of several stages of amplification, we can obtain enormous amplification of the original potential acting on the antenna. By this means, then, it is possible to have voltages acting on the detector which otherwise might be so weak as to be ineffective in operating the detector.

It might appear to the student that with such enormous values of amplification that the latter tube would be overloaded. This would be the case if it were not for the fact that the voltage induced in the antenna by the radiated wave is so very small. In fact, this signal voltage acting on the antenna is

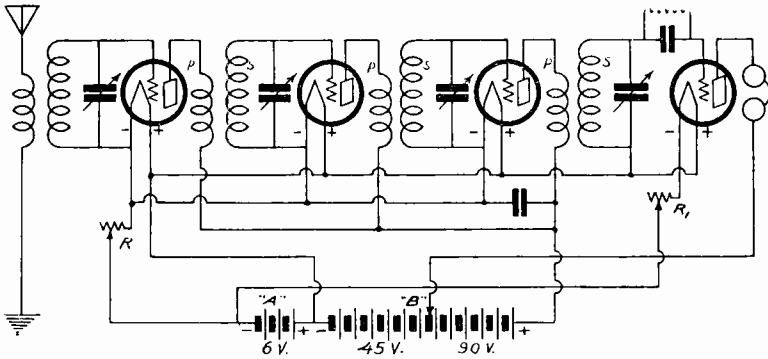

Fig. 15—Three Stages of Radio-Frequency Amplification and Detector Circuits.

represented in microvolts (millionths of a volt). Ordinarily, it takes about 5 microvolts (.000005) to actuate the grid of a vacuum tube so as to give an appreciable change in the plate current. From this, then, it can be seen that with 5 microvolts acting on the grid of the first tube in a cascade amplifier, the amplification could be increased by several stages by 1,000,000 before 5 volts would be acting on the grid of the last tube. In cases where considerable voltage is acting on the grid, it is necessary to use larger tubes which require higher grid bias in order to prevent overloading. Remember, always, that it is necessary to have a tube which will require a negative bias great enough in order that the applied signal voltage is never greater than the bias voltage. If the signal voltage should be greater than the bias voltage, then the grid would become

positive with respect to the filament, resulting in a slight grid current, which would result in a slight decrease of the plate current instead of a proportional increase when the grid is positive. It is highly desirable that the plate current should never be decreased by a grid current, and for this reason, tubes of varying characteristics are manufactured so as to provide tubes which will allow a greater amount of grid signal voltage to be applied without drawing a grid current, resulting in a form of distortion.

CLASSIFICATION OF AMPLIFIERS

An amplifier generally consists of two or more vacuum tubes so arranged that the varying signal voltage is impressed upon the grid of the first tube, thus producing a variation of the plate current in this tube; this varying plate current is made to produce a varying voltage between the grid and filament of the second tube, and, similarly, the varying voltage is relayed from the second tube to the detector tube wherein detection takes place. Since the function of the detector changes the form of plate current, making the audio-frequency part of the signal voltage available, it can be followed by several stages of audio amplification. The stages which precede the detector are usually referred to as *radio-frequency amplifying stages*, because the frequency of the signal voltage is varying at a radio-frequency or above the range of audibility, which is in the neighborhood of 10,000 cycles. The stages following the detector are usually referred to as *audio-amplifying-frequency stages* that amplify the signal voltage which is varying at an audio-frequency, or below something like 10,000 cycles.

From this brief description, it is plain that the signals must be "repeated" from one tube into the next. Amplifiers, either for radio-frequency or for audio-frequency, are divided into the following classes, according to the arrangement used for "repeating": (1) *Transformer-repeating amplifiers*. (2) *Resistance-repeating amplifiers*. (3) *Inductance-repeating amplifiers*.

A tube, together with all co-acting apparatus used for amplifying purposes, is known as "a stage of amplification"; an amplifier consisting of a certain number of stages of amplification.

The two terminals of the amplifier upon which the incoming signal voltages are impressed are known as the "input"

terminals, while the two terminals across which exists the amplified signal voltages are known as the "output" terminals.

TRANSFORMER-REPEATING AMPLIFIERS

Transformer-repeating amplifiers are used for amplifying both radio-frequency and audio-frequency signals, and we will discuss their principle of operation by referring to Fig. 16 which is intended to represent an audio-frequency transformer repeating, two stage amplifier. The radio-frequency transformer practically always uses a tuning condenser across the secondary coil, and thus this coil has quite an appreciable current; whereas the secondary of the audio-frequency transformer has very little current.

The audio-frequency varying potential is connected at Pb and stepped up by means of the transformer T1, after which it

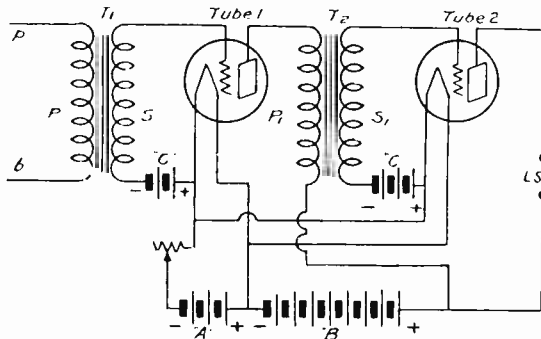

Fig. 16—Circuits of Two Stage Audio-Frequency Amplifier.

is applied between the grid and filament of the first tube; this produces a corresponding variation of the plate current of tube 1. The varying current flowing through the primary P1 of the transformer T2 induces an alternating voltage in the secondary S1. This voltage is applied to the grid and filament of the second tube, and thus the varying signal voltage is repeated from the first into the second tube, and finally from the second tube, varying plate current is caused to affect the loudspeaker (L.S.)

RESISTANCE-REPEATING AMPLIFIERS

The circuit diagram of Fig. 17 shows a three stage resistance-repeating or resistance-coupled amplifier. The incoming

signal voltage is applied to the point Pb and is caused to affect the grid of Tube 1 through the means of the high resistance R. The grid and filament of Tube 1 are connected across the resistance R, through the comparatively large condenser C1; a grid leak resistance r1 is connected from the grid to the filament.

In an amplifier of this type instead of using transformers to pass the energy from one tube to the next, the voltage drop across a resistance in the plate circuit (R, R1 and R2) supplies the change in potential to the grid of the next tube.

In order to insulate the grids of the amplifying tubes from the "B" battery, blocking condensers C1, C2 and C3 are inserted between the plate and grid. Grid leaks r1, r2 and r3 are also necessary to provide a leakage path for the charges which would otherwise accumulate on the grids of the tubes.

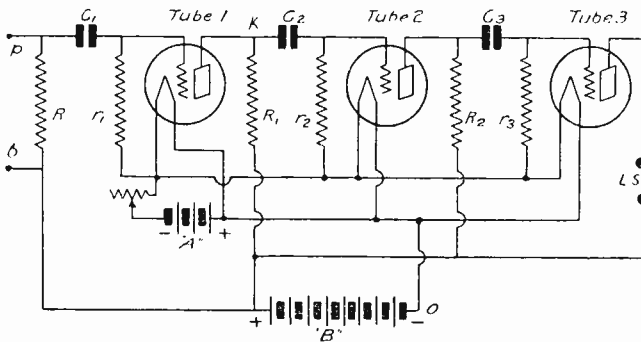

Fig. 17—Circuit Diagram of Three Stage Resistance Coupled Audio-Frequency Amplifier.

The variation of the grid potential of Tube 1 will cause a corresponding variation in the plate current in this tube, and hence a varying difference of potential will exist across the high resistance R1. Since the point O is at constant potential, it is plain that the potential difference between the points K and O will be varied and, as the battery resistance is comparatively low, the variation of this potential difference must necessarily be very nearly the same as that across R1.

The grid and filament of tube 2 are connected across K and O through the comparatively large condenser C2, and any variation in the potential difference across K and O will be impressed on the grid of tube 2; in other words, the signal

will be repeated into the second tube by means of the repeating resistance R1.

In a similar manner, the signal will be repeated from tubes 2 to 3 where it will be picked up on the speaker.

The resistances R, R1 and R2 are generally in the order of 100,000 ohms. The capacity of the condensers C1, C2 and C3 generally lies between .01 and .1 microfarad. The larger the capacity of these condensers, the better the low-frequency currents will be passed. The leak resistances r1, r2 and r3 which make the tubes stable depends upon the type of tubes used, they may be anything between 250,000 and 1,000,000 ohms for tubes now generally used as amplifiers.

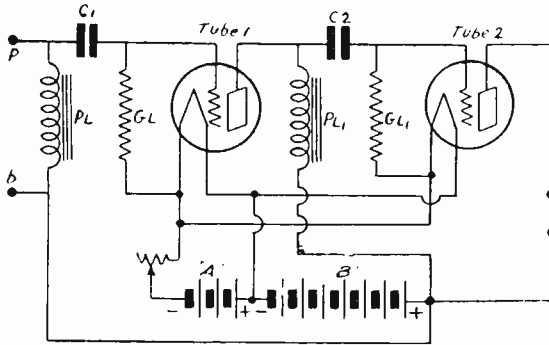

Fig. 18—Circuits of an Inductance Coupled Audio-Frequency Amplifier, Sometimes Called Impedance Coupling.

INDUCTANCE-REPEATING AMPLIFIERS

This type is similar to the resistance-repeating amplifier, except that instead of a resistance in the plate circuit of each amplifying tube, an *inductance or impedance* coil is used whose reactance, at the frequency for which the amplifier is designed, is high. The theory upon which the repeating action from tube to tube is based exactly the same as for the resistance-repeating amplifier. This method of repeating has an advantage over resistance-repeating in that the repeating inductance offers but little opposition to the flow of direct current through the plate circuit, and hence the "B" battery may be of lower voltage than if resistance-repeating were used. The inductance type of repeating amplifier circuit is shown in Figure 18.

PUSH-PULL AMPLIFIER

When a large amount of volume is required from a radio receiver or loud-speaker, the set must amplify the signal sufficiently to produce the required signal energy to be delivered to the speaker. The power is the last stage of an amplifier and may be so large that the vacuum tube in that stage of amplification is overloaded, resulting in distortion. One way to avoid distortion of the signal frequency is to use a power tube. The most popular method, however, is to use the push-pull amplifier, as shown in Fig. 19, which generally replaces the second stage of amplification.

The input transformer T1 uses a split secondary winding having a tap used as a common filament terminal at the electrical center. This center-tap is connected to a "C" battery to the filaments of the tubes in the usual way. The two grid

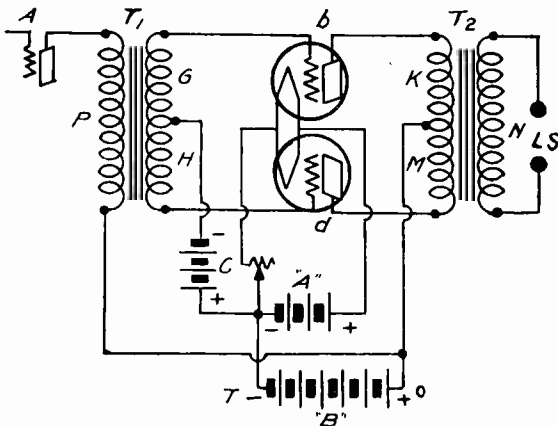

Fig. 19—Circuits of Push-Pull Audio-Frequency Amplifier.

terminals are connected to the grids of the two tubes. The output transformer T2 has a split primary winding with plate terminals at its two ends and a "B" battery terminal brought out from the electrical center of the primary winding. This output transformer has a single secondary winding which is connected to the loud-speaker.

Since the signal potentials on the grids of the two tubes B and D are 180 degrees out of phase (one is always + or — with respect to the other), the fundamental plate currents in the two plate circuits differ by 180 degrees. It will be evident from the foregoing that the current directions at any in-

stant in the primary of T2 add together since an increasing current through the upper half of the winding produces the same effect as the decreasing current in the lower half, and vice versa.

The current that flows to the loud-speaker from the secondary of T2 is the result of the voltages of the two tubes acting together. With two power tubes connected as shown, the distortion is smoothed out, as this arrangement produces a current curve almost perfectly symmetrical. However, true push-pull action can only be obtained when the two tubes have the same characteristics (matched tubes), and the input and output transformers have accurately located center taps.

TEST QUESTIONS

Number Your Answers 11--2 and Add Your Student Number

Never hold up one set of lesson answers until you have another set ready to send in. Send each lesson in by itself before you start on the next lesson.

In that way, we will be able to work together much more closely, you'll get more out of your course, and better lesson service.

1. Name the three general types of materials used in the construction of the filament of vacuum tubes.
2. What effect does placing a negative charge on the grid have on the plate current?
3. Upon what portion of the characteristic curve should the tube act when used as an amplifier?
4. In Fig. 13, what is the plate current when the grid voltage is 3 volts negative?
5. What is the meaning of the amplification factor of a vacuum tube?
6. What is cascade amplification?
7. Name three classes of amplifiers.
8. What are the input and output terminals of an amplifier?
9. What is the purpose of the blocking condenser in a resistance-coupled amplifier?
10. Draw a circuit diagram of an inductance-coupled audio frequency amplifier.

