

**MIDLAND RADIO  
AND TELEVISION  
SCHOOLS  
INC.**

**POWER & LIGHT BUILDING, KANSAS CITY, MISSOURI**

**UNIT  
NO.  
2**

**FUNDAMENTAL  
SERVICE  
INSTRUMENTS**

**LESSON  
NO.  
1**

# RADIO PICTURES OVER THE SEA

.....another miracle of science.

In years gone by, pictures of European events of interest could not be published in American newspapers until the photographs were delivered to our shores by ocean liners. Days were lost in transportation, and in many instances, the pictures lost much of their appeal because they appeared in the papers long after the story had been published. News could be flashed across the ocean by radiotelegraph, but pictures were relegated to boats, making it impossible to publish them together.

To the average person, the transmission of pictures through the air appeared as an insurmountable problem. But not to the scientists. They tackled the problem with determination. Large sums of money were spent in research work. A practical system of transmitting radio pictures was created and developed to a high degree of perfection. Today, RCA has an overseas facsimile system that makes possible the exchange of pictures between the United States and Europe in a remarkably short period of time.....just a few minutes being required for each picture.

To just state the bare fact that RCA is transmitting radio pictures across the Atlantic Ocean does not do justice to the magnitude of such an accomplishment. Neither does it portray the opportunities that such achievements open to ambitious young men like yourself. Radio facsimile is just ONE phase of radio. There are many other adaptations of radio that are equally as amazing and they all spell O-P-P-O-R-T-U-N-I-T-Y for you.

To take full advantage of the money-making opportunities in the field of radio, you must have a thorough knowledge of all subjects involved. So apply yourself to your studies and experiments with determination....when you need assistance, ask for it, and always remember that the time you invest in your training now can pay you rich dividends in the future.

Copyright 1941

By

Midland Radio & Television  
Schools, Inc.

PRINTED IN U.S.A.

**JONESPRINTS**

KANSAS CITY, MO.

## Unit Two



# MODERN METHODS of SERVICING RADIO RECEIVERS

"In the earlier days of Radio, almost anyone could profess to be a Radio Service-Engineer. In those days, it was necessary to only change tubes and test the batteries to remedy 90% of the troubles encountered. This was during the era of the 1, 3 and 5-tube battery sets.

"Today, modern radio receivers are quite complicated. Innovations, undreamed-of in the earlier days of Radio, are now incorporated in practically every modern receiver. While these sets give less trouble than the older models, because of the improvements in tubes and associated equipment, still, when trouble does occur, only a trained technician is really qualified to service the modern-day sets.

"Since receiver complications are increasing, I have included ten important lessons on Modern Radio Servicing. In this unit you are going to study how to use all of the modern types of radio servicing equipment. Definite procedures will be given you for the routine testing of tubes and complete receiver circuits.

"After you have completed Units One and Two, you should have no difficulty whatsoever in setting yourself up in the radio servicing profession. You are truly qualified to call yourself a Radio Service-Engineer. Even though you may not intend to follow servicing as your life's profession, the knowledge gained in these two units will prove quite beneficial in mastering the balance of your course."

# Lesson One

## FUNDAMENTAL SERVICE INSTRUMENTS

"A radio receiver is no longer a "gadget", but rather represents the conclusive product of intelligence and precision engineering. There are two main requisites if the service engineer is to be successful in servicing such equipment. First, he must be thoroughly familiar with all types of receiver circuits; and second, he must have complete information on all modern types of servicing equipment and an understanding of how to use this equipment most effectively."

"In this lesson, I am first going to take up a thorough discussion of fundamental service instruments. This material is designed to acquaint you with the various types of instruments available to the serviceman, as well as information covering their operation. The material is quite important; because, after all, a serviceman cannot expect to do an efficient job unless he thoroughly understands the equipment with which he is working."

1. CONTINUITY METERS. The simplest instrument used in radio servicing is the so-called "continuity meter". Fig. 1 shows the circuit of this unit. It consists of a battery, a variable resistor, and a meter connected in series. The two ends of the series circuit are brought out to two probe leads. The meter is usually a low reading milliammeter such as a 0-1 or 0-5. This size meter is chosen to lengthen the life of the battery and also to make better continuity checks of higher resistance units. The value of the variable resistor can be calculated from our knowledge of Ohm's Law. If we are using a 0-1 milliammeter and 1.5 volt flashlight cell, then from Ohm's Law we calculate:

$$R = \frac{E}{I} = \frac{1.5}{.001} = 1500 \text{ ohms}$$

We can, therefore, use a 1500 or 2000 ohm variable resistor and even though the test probes are shorted, the current through the meter will not be great enough to burn out the meter. To set up this instrument for use, the two test probes are shorted together and the variable resistor adjusted until the meter reads near the higher end of the scale. The actual reading is not important.

This meter is primarily used, as its name suggests, to follow the continuity<sup>1</sup> of circuits in a radio receiver. This meter will show open circuits or shorted circuits, but, in its present form, will not indicate the resistance of the circuit under test. As a

<sup>1</sup>"Continuity" means a continuous electrical connection with a minimum of resistance.



rule, this instrument is used only for quick checks on receivers to check suspected circuits for opens or shorts, and is not used where precision measurements are required.

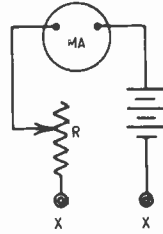

Fig. 1 A simple continuity meter.

2. OHMMETERS. It is doubtful that any modern radio receiver passes through a service shop without some resistance measurements being made to either locate or repair trouble. Since it is so important to make so many resistance measurements, it follows that a service engineer must be thoroughly familiar with the various instruments for making these measurements.

There are several methods of making these measurements, all of which are covered by the general name of "ohmmeter". These are:

1. The series ohmmeter
2. The shunt ohmmeter
3. The ammeter-voltmeter method
4. The voltmeter method
5. The Wheatstone Bridge

It is a well-known fact that the range of resistances used in radio receivers is far greater than in other electrical work. Values of from a fraction of an ohm to several megohms are found in modern receivers. The instruments used must cover these ranges with a minimum of switching.

An ohmmeter is an instrument which measures resistance directly without the necessity of making calculations of any kind. As it is the one basic instrument used by all service engineers, we will cover all of the standard ohmmeter circuits.

There are two types of ohmmeter circuits, differing mainly in the method of measuring the resistance and in the method in which the unknown resistance is connected in the meter circuit. These two types are identified as the shunt type and the series type. In some instruments, both types of circuits are combined.

The fundamental circuit for the series type ohmmeter is shown in Fig. 1; the same fundamental circuit as for the continuity meter. It consists of a battery and a variable resistor in series with a milliammeter. When the two terminals x-x are shorted, the variable resistance is adjusted until the meter reads at full scale. This point is then "0" ohms. The calibration for such an ohmmeter is fixed. For example, let us assume that we are using an 0-1 milliammeter. At full scale, the resistance is 0 ohms. If a 1.5 volt flashlight cell is used, the resistance of the variable resistor will be 1500 ohms. Now assume a 1000-ohm resistor

is placed across x-x. The total resistance of the circuit is now 2500 ohms. From Ohm's Law we find that:

$$I = \frac{E}{R} = \frac{1.5}{2500} = .0006 \text{ Amp. or } .6 \text{ Milliampere}$$

Therefore, the calibration for 1000 ohms is the same as .6 milliampere. From the above, it can be seen that a standard calibration can be set up with a minimum of trouble.

If an unknown resistance is placed across x-x, the increase in the series resistance will cause less current to flow, resulting in a lower meter reading. The higher the value of resistance, the lower will be the meter reading. In other words, the upper end of the scale is the lower resistance. Therefore, in the series type ohmmeter, the left end of the scale always represents infinite resistance or open circuit, and the right end of the scale represents minimum resistance or short circuit. This, as you will notice from the illustration in Fig. 2, is the opposite of standard ammeter scales.

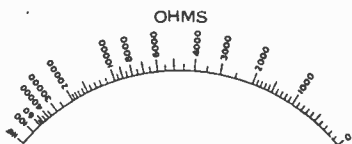

Fig. 2 Scale of series ohmmeter.

The variable resistance shown at R in Fig. 1 is known as the current limiting or zero adjusting resistor. It is made variable to allow for the drop in battery voltage with age. As the battery voltage drops, the resistance R can be decreased in order to bring the meter reading up to full scale when the terminals x-x are shorted. It is the usual practice to check this setting every time the instrument is used.

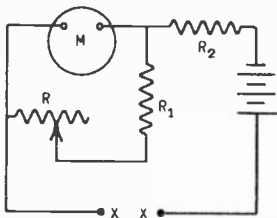

Fig. 3 Zero adjustment of an ohmmeter.

Another method for zero adjustment is shown in Fig. 3. In this method, a fixed resistor and a variable resistor in series are connected in parallel with the meter. The fixed resistor is a necessity as a current limiting resistor to prevent short-circuiting the battery. In this circuit, when the battery ages, the variable resistance is increased, thus lowering the shunted current and increasing the current through the meter when the terminals x-x are shorted. This type of circuit is commonly used in commercial instruments as it gives a greater degree of accuracy

after the battery voltage has dropped, due to age.

The shunt type ohmmeter is shown in schematic form in Fig. 4. Here, as in the series type ohmmeter, we have a meter, a battery, and a variable resistance, connected in series. However, the resistance to be measured is shunted across the meter instead of in series with it as in the case of the series type meter.

Fig. 4 A shunt type ohmmeter.

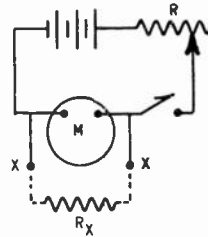

The operation of this type meter is as follows: The switch is closed and the variable resistance is adjusted until the meter reads full scale. You will note that this adjustment is made *without* the test probes shorted, as was the case in the series type ohmmeter. The unknown resistance or the resistor to be measured is then connected across the test probes (x-x in Fig. 4). A part of the current flowing through the meter will now be shunted through the unknown resistor. The amount of current shunted in this way will depend upon the value of the unknown resistor. Then the meter will read less current by the amount being shunted through the unknown resistor. The lower the value of the resistance, the more current will be shunted from the meter and the lower the reading on the meter. Therefore, in place of calibrating the meter in milliamperes, it can be calibrated directly in ohms.

Then in comparing the series type ohmmeter and the shunt type ohmmeter, one great difference is immediately apparent. In the shunt type of meter, the calibration is the same as in voltmeters, ammeters, etc.; that is, the lowest resistance values will be at the left end of the scale and the higher resistance values will be at the right end of the scale. However, the exact opposite is the case in the series type ohmmeter.

Examining the above circuits, it is easily seen that it is not practical to measure extreme ranges of resistance on a single scale. Resistances from 3 ohms to 5 to 10 megohms are found in modern radio receivers. If this wide range were put on one scale, accurate measurements could not be made. For example, in the series type ohmmeter, an 0-1 milliammeter is generally used. Each division of the meter is then equal to .02 milliamperes. If a 4.5 volt battery is used, each division would indicate a resistance change of 225,000 ohms. (For the sake of brevity, this calculation was made, assuming that no adjusting resistor is in the circuit.) From this, it can be seen that a resistance of 3 ohms would not make a movement in the indicating pointer.

To remedy this condition, all modern types of ohmmeters are designed with at least two and sometimes more, scales to cover the extreme ranges of resistance. Obviously, the greater the number of ranges used, the more accurate the measurements that can be made, as the resistance per scale division is correspondingly lower.

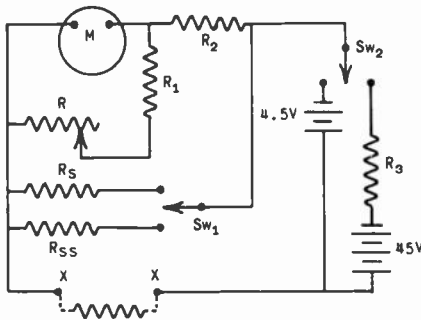

Fig.5 A series ohmmeter with several ranges.

Fig. 5 shows a series type ohmmeter with provisions for extending both the low and high resistance ranges. To explain these, let us assume that the normal accurate resistance range is from 100 to 100,000 ohms. If a resistance of less than 100 ohms is connected across x-x, the meter would read so close to the high end that an accurate reading could not be made. To enable readings of less than 100 ohms accurately, the proper amount of resistance is shunted around the meter. This resistance is shown as  $R_s$  in Fig. 5. To change the range of the meter to 10 to 10,000 ohms, this resistance should be of such a value that 9/10 of the current is shunted around the meter by means of the resistor  $R_s$  and only 1/10 of the total current flows through the meter. The range of the meter can be still further lowered by means of an additional resistor  $R_{ss}$ . By using the switch designated  $Sw_1$ , any of the three ranges can be obtained by simply turning the switch to the desired position.

In order to measure higher resistance values, it is only necessary to increase the battery voltage to force the current through the higher resistance. If the normal range of an ohmmeter is 100,000 ohms when a 4.5 volt battery is used, the range can be made 10 times as high (1,000,000 ohms) if a battery having 10 times the voltage (45 volts) and a current limiting resistance having 10 times as much resistance are used. In Fig. 5, switch  $Sw_2$  is used for changing from 4.5 to the 45 volt battery. The additional current limiting resistor  $R_3$  is connected in series with the 45 volt battery so that when the battery is switched into the circuit, the resistance is automatically connected. In commercial ohmmeters, switches  $Sw_1$  and  $Sw_2$  are usually ganged together so as to provide a single control for the selection of all ranges. In some types of instruments, push button switches are used in place of rotary switches.

Now let us examine the shunt type meter to determine how the ranges may be extended. In this type of meter, the high range is limited by the internal resistance of the meter; that is, the meter is an ammeter, and, therefore, the internal resistance is very low. If a high unknown resistance is placed across the test probes, the current shunted through the test probes and, in turn, through the unknown resistance, is such a small part of the total current that no change can be noticed on the meter. However, the range of the shunt type meter can be very easily extended in the lower resistance direction.

Fig. 6 (A) Method of extending the range of a shunt ohmmeter. (B) Test leads as used with an ohmmeter.

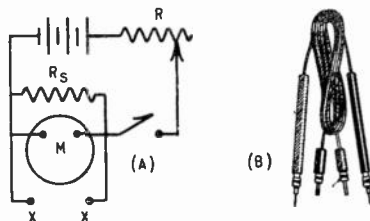

To extend the low range of a shunt type ohmmeter, it is only necessary to shunt the meter with a resistance such as  $R_S$  in Fig. 6A. Let us assume that the value of resistance  $R_S$  is equal to the internal resistance of the meter used. Therefore, one-half of the battery current will flow through the meter and one-half through the shunt resistance  $R_S$ . Decreasing the size of the series resistance  $R$  to one-half its former value allows twice as much current to flow through the entire circuit; therefore, the current through the meter will again be sufficient for full-scale deflection. Insofar as resistance measurements are concerned, the internal resistance of the meter is now one-half its former value, because of the shunt resistor  $R_S$ . Any given resistance now connected across terminals x-x will cause less lowering of the meter reading than would occur with the previous circuit arrangement, so now it requires a much lower resistance to bring the meter pointer near the left end of the scale. Therefore, the ohmmeter is now able to accurately measure lower resistances than before.

From our studies of the two types of ohmmeters above, one outstanding difference is noticed. The series type ohmmeter is best suited for the measurement of medium and high resistances, while the shunt type ohmmeter has the advantage of being especially suited for the measurement of very low resistances without placing a heavy current drain upon the battery. In commercial type instruments, it is usual to so arrange the ohmmeter circuits that both circuits are used. For low resistances, a switch or switches arrange the circuits for shunt type operation, and for high resistance measurements, these same switches arrange the circuit for series operation.

Although it is possible to purchase ohmmeters as such, more modern instruments combine the ohmmeter with other meters in what is now known as the Universal Meter. For this reason, we will not

touch upon actual commercial type instruments at this point, but will cover them in that section covering Universal Meters.

Before passing from ohmmeters, however, let us point out three special precautions that should be carefully watched in the use of ohmmeters.

1. Before every resistance measurement, make certain that the zero adjustment has been made. Failure to do this may cause erroneous resistance readings, which, in turn, may result in false deductions as to conditions within the receiver under test.
2. Whenever completing tests on the ohmmeter, make certain that the operating switch is placed in the "Off" position. This is important in both series and shunt type ohmmeters to prevent any excess drain on the battery. In the case of the shunt type meter, we can see by examining the circuit diagram, that with the operating switch closed there is always current flowing. In the case of the series type ohmmeter, if the operating switch is left on the "On" position, it is possible for the test leads to become accidentally shorted and thus cause an unnecessary battery drain.
3. In making resistance measurements, it is necessary to make certain that the fingers do not touch the metal contact points on the test probes, especially when measuring high resistances. If this occurs, the ohmmeter will read or indicate a lower resistance value than is actually being measured. This is true because the resistance being measured is placed in parallel with the resistance of the human body. This resistance may vary from 10,000 to 100,000 ohms, depending upon how good the contact is between the fingers and the metal test probes. If the fingers are moist, a good contact will be made and the body resistance will be low. From our study of Ohm's Law, we can appreciate that placing this amount of resistance in parallel with another unknown resistance will very materially affect our final reading. Because of this, it is very important to keep the fingers away from the metal points of the test probes, holding the probes only by the insulated handles. Fig. 6B is a photograph of a pair of commercial test probes.

Except by the use of ohmmeters, the easiest method of measuring resistance is by the use of a voltmeter and an ammeter. The current through the unknown resistance is measured by an ammeter, and the voltage across the resistance is measured with a voltmeter. From Ohm's Law, the unknown resistance can be calculated. This method has been thoroughly covered in a previous lesson, so no more space will be given at this point.

Another method known as the voltmeter method requires only a voltmeter and a DC source of power to make measurements. Either a 45 volt battery or a 110 volt DC line will do. The first step is



to measure the battery or line voltage  $E_S$ . Next, the unknown resistor is placed in series with the voltmeter and the source of power. The voltage  $E_R$  is then read. From these voltages we can calculate the unknown resistance  $R_X$ , from the following formula:

$$R_X = \left( \frac{R_M \times E_S}{E_R} \right) - R_M$$

Where  $R_M$  is the internal resistance of the meter.

Still another method of accurately measuring resistances is by means of a Wheatstone Bridge. As the principles of the Wheatstone Bridge have been covered before, we will give no further space at this point. There can be no question as to the accuracy of the Wheatstone Bridge, but the time required to operate makes the unit more or less a laboratory instrument rather than a service instrument.

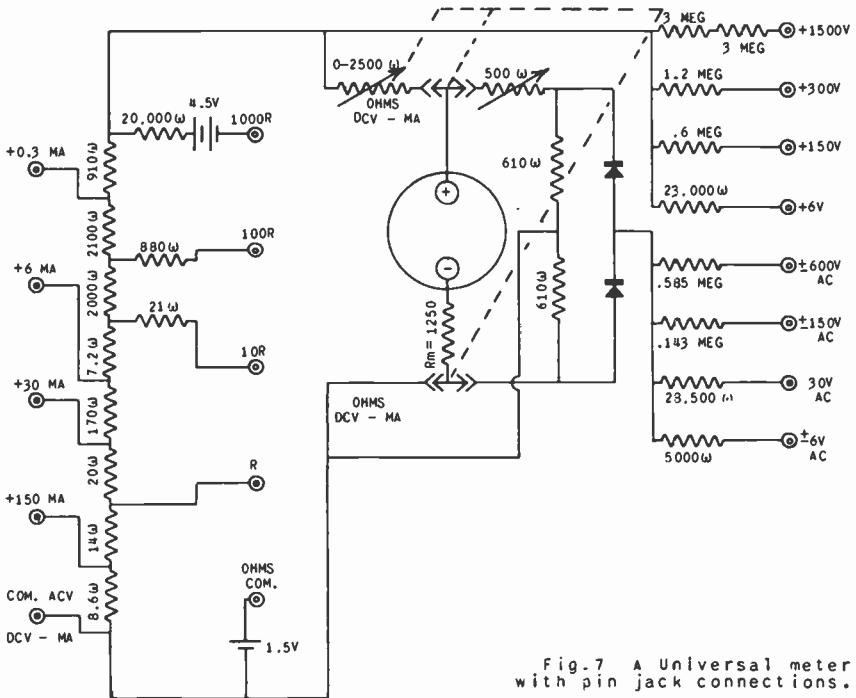

Fig. 7 A Universal meter with pin jack connections.

Two other instruments used extensively in radio service work are the voltmeter and milliammeter. The use of these instruments was covered in Unit 1 of your course. However, as these instruments are also usually combined in the Universal meter, they will be treated more in detail under that subject.

3. UNIVERSAL METERS. In all service work, perhaps the most used instrument, as well as the easiest instrument to learn and understand, is the Universal Meter. This meter may appear under

any number of trade names, but as a rule is designed for the following purposes:

1. Ohmmeter (2 to 3 ranges)
2. Voltmeter (Several ranges for both DC and AC)
3. Milliammeter (Several ranges)

As a rule, a single DC meter is used as an indicating unit for all the above measurements. AC and output measurements are obtained by the use of a rectifier in the meter circuit. In some instruments, however, a separate AC meter is provided for the AC and output measurements.

The sensitivity of the voltmeter section of the meter is dependent upon the meter used. In most cases a milliammeter movement is used; for example, an 0-1 milliammeter. Now, if it is desired to have the full scale reading to be 10 volts, we can determine the amount of resistance to be placed in series with the meter from Ohm's Law ( $E = IR$ ). In this case, we know that  $E = 10$  volts and  $I = 1$  milliamperes or .001 ampere. From the above equation we find that:

$$10 = .001 \times R, \text{ or } R = 10,000 \text{ ohms}$$

From this we can see that the resistance of the meter and resistor is equal to 10,000 ohms or 1000 ohms per volt. This is the usual method of expressing the sensitivity of a voltmeter. Most modern instruments use a 0-100 or 0-50 microammeter, which gives a sensitivity of 10,000 and 20,000 ohms per volt respectively.



Fig. 8 Photograph of the Universal meter whose diagram is given in Fig. 7. (Courtesy, Supreme Instruments Corp.)

In order to more fully understand the various circuits of a Universal meter, let us examine a typical circuit. Fig. 7 shows a type of instrument in which all circuits are brought to pin jacks and range changes are made by changing the test leads from one pin jack to another. Such an instrument is pictured in Fig. 8. In examining the circuit, we see the following ranges are available.

1. 4 ohm ranges; 0-2000, 20,000, 200,000 ohms, and 2 megohms.
2. 4 DC milliamperes ranges, 0-0.3, 6, 30, 150 milliamperes.

3. 4 DC volts ranges; 0-6, 150, 300, 1500 volts.
4. 4 AC volts ranges; 0-6, 30, 150, 600 volts.

Also, upon further examination, we see that a DPDT switch is provided to change from DC to AC ranges.

To assist in the study of this meter, let us first use only the ohmmeter circuit as shown in Fig. 9. From this circuit, we find that it is simply an adaptation of that shown in Fig. 5. The resistors  $R_1$ ,  $R_2$ ,  $R_3$ , and  $R_4$ , are the shunt resistors. On some ranges they are in series with the meter, and on others they are in shunt with it. The battery in the 1000R position accomplishes the same purpose as the extra battery shown in Fig. 5 as a 45 volt

Fig. 9 The ohmmeter circuit of the Universal meter.

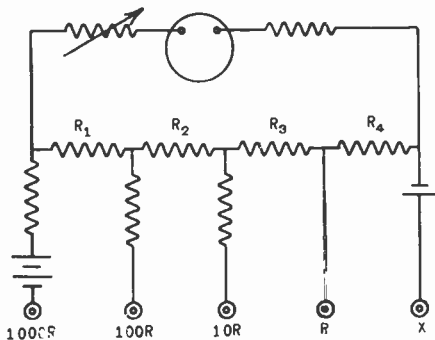

battery. If an unknown resistor is placed across  $X$  and  $R$  in Fig. 9, a certain amount of current is by-passed through the shunt resistor and the unknown resistor, giving a certain meter reading. Now, with the same unknown resistor connected across the terminals  $X$  and  $10R$ , there is less current by-passed, and the meter will give a lower ohmmage reading. By proper arrangement, and with the correct values of resistors, this latter reading is one-tenth of the original reading. This same reasoning applies to the  $100R$  tap.

Fig. 10 The milliammeter circuit of the Universal meter.

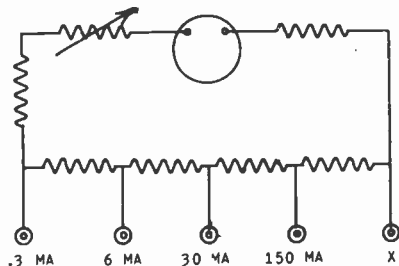

Fig. 10 shows the milliammeter section of this Universal meter by itself. Let us first look at the 150 milliamper section. With the two leads connected one to the common terminal and the other to the 150 milliamper terminal, we find that the resulting circuit is a parallel system. In one leg is the 8.6 ohm

resistor and in the other leg is the balance of the resistance and the meter. In other words, the greater portion of the current will pass through the low resistance leg and only a small portion will flow through the meter circuit. Now if the connection is moved to the 30 milliampere tap, we find that the low resistance

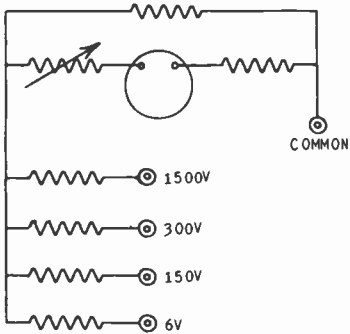

Fig.11 The voltmeter circuit of the Universal meter.

leg now has a higher resistance, and the meter leg of the parallel system has been decreased accordingly. In this case, the current will be divided so that more current passes through the meter, giving a correspondingly higher reading. The exact value of the current in each leg can be calculated from the size of the meter used.

Fig. 11 shows the voltmeter section of this Universal meter. The resistance in parallel with the meter is not necessary, but for simplicity of design of the other parts of the Universal meter, it is connected permanently in the circuit. This shunt resistance does, however, tend to require smaller series resistors

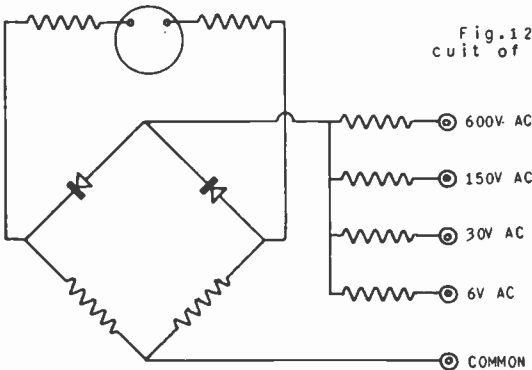

Fig.12 The AC voltage circuit of the Universal meter.

in the voltmeter section. From our previous discussion of meters and the various methods of obtaining or changing the effective range of these meters, we can readily understand that the series resistance for the 6 volt scale will be considerably less than for

the 150 volt scale. Likewise, the series resistance for the 150 volt scale is less than that for the 300 volt scale, and the series resistance for the 300 volt scale is less than that for the 1500 volt scale.

Fig. 12 shows the AC voltage circuits of the Universal meter. Since we are using the same meter as was used for the DC measurements, some means of rectification must be provided. In this case, a half-wave rectifier is used in a conventional bridge circuit. The third and fourth legs of the bridge are formed by resistors of identical resistance. Our previous studies of the principles of rectification enable us to thoroughly understand how this system operates. As in the case of the DC voltmeter, series resistances of increasing values give us increased voltage range.

As the rectifier is of such a nature that its efficiency remains fairly constant over the audio frequency range, the AC voltmeter section may also be used as an output meter.

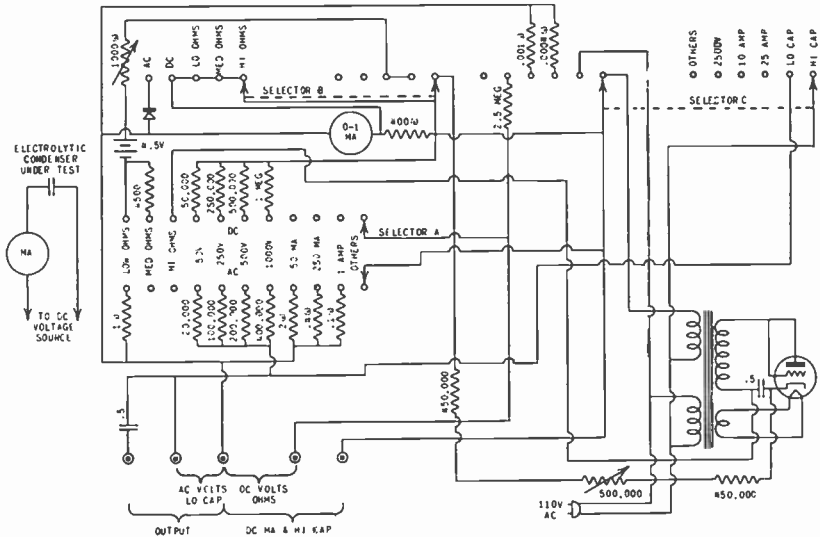

Fig. 13 A Universal Meter which measures resistance, current, voltage, capacity, and inductance.

We have discussed in the previous paragraphs the simplest form of Universal meter. Modern Universal instruments now combine many more functions than just the measurement of current, voltage, and resistance. For example, Fig. 13 shows a schematic diagram of a Universal meter which not only measures resistance, voltage, and current, but also capacity and inductance. A picture of such a unit is shown in Fig. 14. Referring to Fig. 13, we see that three selector switches are used, namely Selector A, Selector B, and Selector C. Selector A, consisting of a 2-pole, 11-position switch, controls the selection of the resistance, voltage, and

low current ranges. Selector B, consisting of a 2-pole, 5-position switch, controls the selection of AC or DC voltages and the three resistance ranges. Selector C, consisting of a 2-pole, 6-position switch, controls the high voltage range, the high current ranges, and the low and high capacity ranges. Test connections are made through 5 tip jacks, various combinations of which give different voltage, current, or resistance ranges.

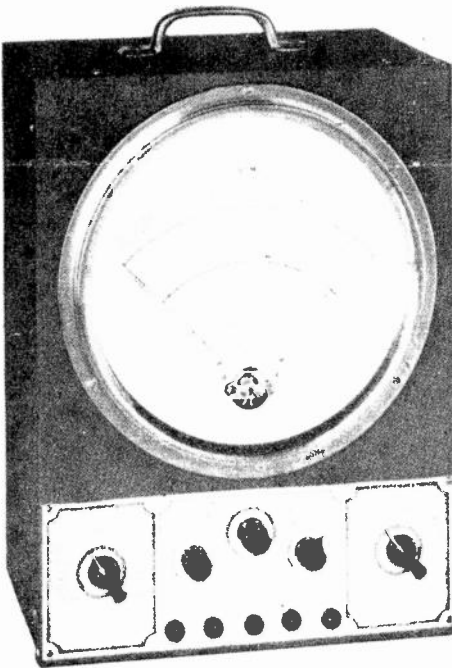

Fig. 14 Photograph of the meter whose diagram is shown in Fig. 13. (Courtesy Superior Instrument Corp.)

In breaking down the schematic diagram shown in Fig. 13, you will find that the three resistance ranges are made up into the series type of ohmmeter connection. Fig. 15A shows the low ohm range circuit in which the meter is shunted by a resistor to increase its low ohm range. Fig. 15B shows the medium range which is nothing more or less than a standard series type ohmmeter circuit. Fig. 15C shows the high resistance range which provides a rather unique system. In place of providing extra batteries to obtain a higher voltage supply, a tube type half-wave rectifier is provided. It should be noted that the power supply is used only for the high resistance measurements. This is to obtain sufficient voltage to get a current flow for the measurement of high resistances. On the lower resistance measurements, the battery supply gives sufficient voltage for this purpose.

Figs. 16, 17, and 18 show the DC voltage, AC voltage and current circuits respectively. All of these circuits are standard



and they have been discussed previously in your course. The DC voltage circuit uses the typical series resistors for range changing. It is to be noted that the 2500 volt circuit is on Selector Switch C, while the other ranges are on Selector Switch A. This is done to prevent any possible breakdown due to the high voltage present. In case higher DC voltage ranges are desired, it is only necessary to add resistance in series with the test leads. For instance, if a 5000 volt scale is required, it is only necessary to add a 2.5 megohm resistor in the test circuit. As the 2500 volt circuit uses a 2.5 megohm resistor, the additional resistor doubles the series resistance, thus doubling the effective voltage range, making it a 5000 volt range.

Fig.15 Ohm range circuits of a modern Universal meter. (A) Low-ohm range; (B) Medium-ohm range; (C) High-ohm range.

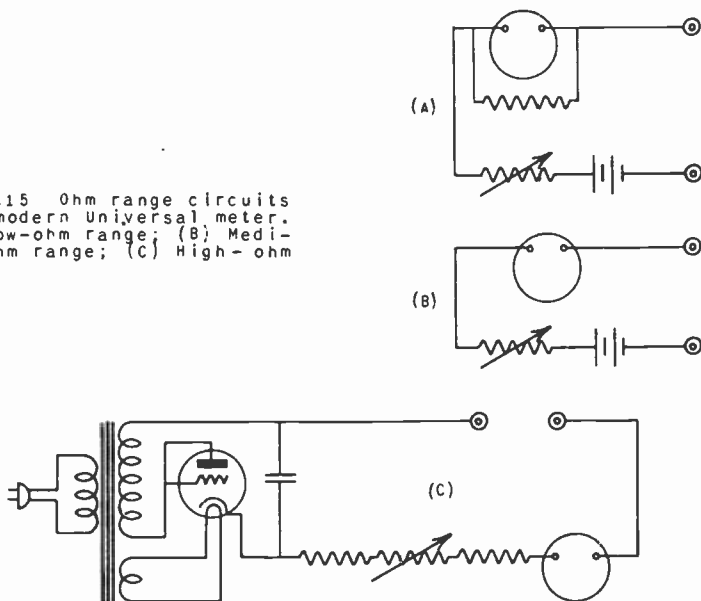

In Fig. 17, we note that the AC voltage range uses a half-wave rectifier. One-half of the AC wave is shunted around the meter, through the copper oxide rectifier whose resistance is extremely low compared to the resistor in series with the meter. On the other half of the wave, the resistance of the copper oxide rectifier is high compared to the resistance of the meter circuit, and, as a result, the value of current flow due to the voltage being measured is indicated on the meter.

Fig. 18 shows that the current measuring circuits are for the standard shunt type of meter. In examining the complete circuit diagram, we see that the 10 ampere and 25 ampere ranges are on Selector Switch C in place of Selector Switch A, with the milli-ampere ranges. This is done to make it possible to use standard commercial switches, which are limited to 11 or 12 points, depending upon the type of switch being used.

Before discussing the remaining circuits in the Universal Meter, let us first study something of capacitors and methods of test. As every piece of modern radio apparatus; either receivers, transmitters, phonographs, or public address equipment, contains any number of various types of capacitors, it is essential that a radio service engineer be capable of making the necessary tests on these units. There are four fundamental things which must be determined in the testing of capacitors. They must be tested for open circuits, short circuits, excessive leakage, and for correct capacity.

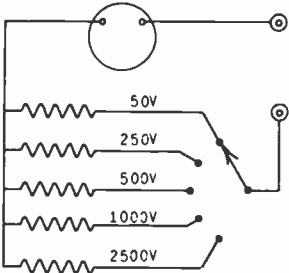

Fig.16 The DC voltage circuit of a modern Universal meter.

There are several types of equipment on the market for making these tests. However, roughly speaking, the instruments known as capacity testers or condenser analyzers must be noted as only being capable of measuring a capacitor for opens, shorts, or leakage; while a capacity meter measures and indicates the capacity of a condenser in microfarads.

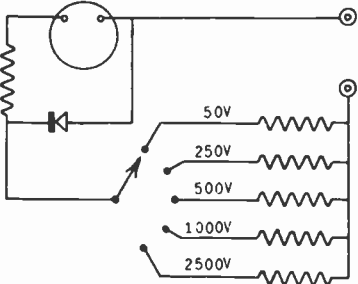

Fig.17 The AC voltage circuit of a modern Universal meter.

The fact that a condenser is shorted, is open, or has an excessive amount of leakage, often is sufficient to cause a radio receiver breakdown. These three defects are the most common found in condensers.

In Unit 1 of your studies, you learned that a capacitor passes AC current. This principle is utilized in the measurement of capacity. Fig. 19 shows the fundamental circuit used. The AC reactance of the capacitor will cause a voltage drop according to the capacity of the unit under test, and the AC meter will indi-

cate the difference between the line voltage and the voltage drop across the capacitor under test. From this, the meter can be calibrated to read capacity directly on the scale, or a graph can be made up calibrated to convert voltage to microfarads. Such a graph is shown in Fig. 20.

Fig.18 The current circuit of a modern Universal meter.

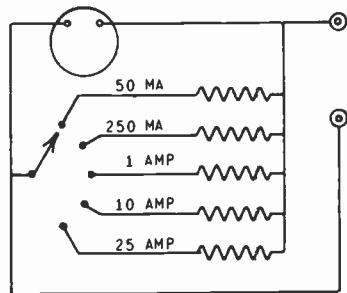

This arrangement also automatically checks the condenser for opens and shorts. If the capacitor is open, no reading will be apparent on the meter. If the capacitor is shorted, the meter will indicate the full line voltage. Using this system, leakage is measured by means of an ohmmeter. In the case of electrolytics, further explanation will be given later.

Fig.19 A fundamental circuit for measuring capacity.

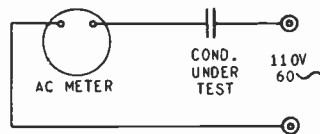

Of course, we again must notice that the Wheatstone Bridge is the most accurate method of measuring capacity. Although the Wheatstone Bridge is extremely accurate, the time consumed does not warrant its use in radio service work. The approximate methods noted above are sufficiently accurate for all general purposes. With these methods, measurement to within 3% to 5% are easily made. As commercial capacitors are not usually held to closer than plus or minus 10%, we can see that close accuracy in service work is not necessary.

Having noted some of the methods of measuring capacity and testing capacitors, let us again refer to the Universal meter shown in Figs. 13 and 14.

Fig. 21 shows the two capacity circuits of this Universal meter. Both use the series method of measurement. Fig. 21A shows the circuit for low capacity measurements, using 110 volt AC as the power supply. Fig. 21B shows the circuit for the high capacity measurements. In this case, power is obtained from the secondary winding of a transformer, and the voltage from this winding is low; usually from 5 to 10 volts. This voltage is low in order to reduce the current flow through the capacitor so that it can be

measured on the same meter scale. Of course, the higher the capacity, the greater the current flow through the capacitor.

Leakage of paper and mica condensers is measured with the ohmmeter. Before any leakage measurement can be made, it is necessary to disconnect the condenser from the circuit and discharge it. To test for leakage, use the high ohm range. As a



Fig. 20 Capacity-voltage calibration graph for Triplet Model 1200-A Universal Meter.

rule, mica condensers have a resistance of at least 10 megohms, but paper condensers have a variable leakage resistance depending upon the capacity. They should have a leakage resistance of at least 1 megohm. Usually, coupling condensers under .1 mfd. have a very high leakage resistance. This resistance may run as high as 10 megohms or even higher.

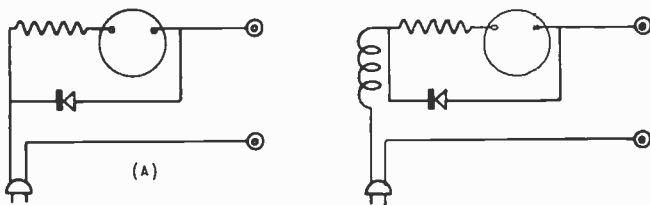

Fig. 21 (A) The low-capacity circuit, and (B) the high-capacity circuit, of a modern Universal meter.

Leakage tests of electrolytic condensers are entirely different. Before any measurements of leakage can be made, the instrument should be set for the 500 ma. range. The condenser to be measured should either be connected across a source of DC voltage or connected in the circuit where it is being used. The

voltage should be equal to the operating or working voltage of the condenser. Make sure the polarity is correct and connect the meter in series with the leads. If the reading is too low, change to a lower range. The leakage current should be approximately  $\frac{1}{2}$  ma. per microfarad. If a 4 mfd. condenser is measured, the leakage current should be no more than 1 ma. A glance at the circuit diagram will show the manner of measuring the percentage of leakage in electrolytic condensers.

In this type of instrument, inductance measurements are made using the capacity circuits. From our study of inductances, we learned that they acted to retard the flow of AC current. From this principle, then, we can see that the higher inductance present the less will be the current flow, which is just opposite of the capacitor circuits. Therefore, in using the capacity scales, a calibration graph or conversion table must be used. Such a table is as follows:

C	L	C	L	C	L
.01	709.	.4	17.6	1.6	4.39
.02	352.	.5	14.1	1.7	4.14
.03	234.	.6	11.7	1.8	3.91
.04	176.	.7	10.	1.9	3.70
.05	141.	.8	8.8	2.	3.52
.06	117.	.9	7.8	3.	2.34
.07	100.	1.0	7.03	4.	1.76
.08	87.8	1.1	6.39	5.	1.41
.09	78.1	1.2	5.86	6.	1.17
.1	70.3	1.3	5.41	7.	1.00
.2	35.2	1.4	5.02	8.	.88
.3	23.4	1.5	4.69	9.	.78
				10.	.70

NOTE: C is in mfd. and L in henries

In using the above conversion table from capacity in microfarads to inductance in henries, the capacity meter should be operated on the highest capacity scale which will give an accurate reading.

Upon examining the circuit shown in Fig. 13, we will notice that the output circuit is exactly the same as the AC voltage circuit except a .5 mfd. condenser is in series with one lead. This acts as a blocking condenser to prevent the passage of any DC current which might affect the readings.

Having studied the various circuits used in the Universal meter, let us now examine the use of this instrument in making various measurements.

To use the DC voltmeter, Selector Switch C is set at "Others", (refer to Fig. 13), as no range on that switch is to be used. Selector Switch B is set at "DC" and Selector Switch A is set at the highest range, or 1000 volts. If the approximate voltage is known, the selector switch is set at the range desired. Test leads are placed in the tip jacks marked "DC Volts" and the

measurements are made. If sufficient indication is not made on the 1000 volt scale, Selector Switch A should be moved to the next lower range. If voltage measurements above 1000 volts are to be made, Selector Switch A should be set at "Others" (refer to Fig. 13), and Selector Switch C should be set at "2500 volts". It is well to point out that in all tests, whether voltage or current, test leads with well insulated handles should be used. On some radio receiving sets, there are voltages present capable of giving a severe shock if accidental contact with them is made. If, when making these measurements, the meter is reversed, it is only necessary to reverse the test leads.

In making AC voltage measurements, Selector Switch C is set at "Others", Selector Switch B at "AC", and Selector Switch A at 1000 volts. The test prongs are inserted in the jacks marked AC volts and the measurements made. Again, if sufficient indication is not obtained on the 1000 volt scale, Selector Switch A should be moved to the next lower range.

As previously explained, if it is desired to extend the range of either the AC or DC voltmeter, it is only necessary to insert a resistor of the proper value in series with the highest range. For example, to extend the range of the AC voltmeter in this meter, it is only necessary to add a 400,000 ohm resistor in series with the test lead. This doubles the series resistance, or, in other words, extends the range of the voltmeter to 2000 volts.

The DC milliammeter is used by setting Selector Switch C to "Others", Selector Switch B to DC, and Selector Switch A to 1 Amp. In making current measurements, remember that the meter must always be in series with the line in which the current is to be measured. If the plate current of a tube is to be measured, the plate lead must be disconnected from the socket. One test lead is then connected to the socket and the other test lead is connected to the plate lead. If insufficient indication is obtained on the 1 amp. scale, the Selector Switch A should be moved to the 250 ma. scale. If the meter is reversed, simply change the test leads. When making measurements on the 10 ampere and 25 ampere ranges, Selector Switch A should be set on "Others" and Selector Switch C adjusted to the proper range.

In order to measure resistance, Selector A is set to low ohms, Selector B to low ohms, and Selector C to "Others". The test probes are placed in the tip jacks marked "Ohms". The test probes are then shorted and the potentiometer is adjusted for "Zero Ohms". This is full scale on this meter. The test probes are then separated, and we are ready for measurements. At this point, let us caution you against erroneous readings when measuring resistors in a receiver. In many cases, resistors as well as capacitors, are in parallel with transformer windings, other resistors, or capacitors. For this reason, it is always wise to disconnect one end of the resistor from the circuit before making any measurements. If this precaution is taken on all occasions, there will never be any question as to the dependability of any measurements you make.

The procedure for making measurements on the medium ohm scale



is as follows: Selector Switches A and B are set on "Medium Ohms" and Selector Switch C is set on "Others". Then proceed as explained in the preceding paragraph.

High resistance measurements are made with Selector Switches A and B set at "High Ohms", and Selector Switch C at "Others". The power supply is then connected to the instrument to supply the higher DC voltage necessary for high resistance measurements. The test probes are again placed in the tip jacks marked "Ohms" and are then shorted. The potentiometer in the power supply circuit is used for the "Zero Ohm" adjustment in this case. After the "Zero Ohm" adjustment, the probes are separated and resistance measurements can now be made.

Capacity measurements are made with Selector Switch A set at "Others", Selector Switch B set at AC, and Selector Switch C set at "High" or "Low Capacity", depending upon the capacity to be measured. The test probes are placed in the proper tip jacks and the power cord connected into a power supply. We are now ready to make measurements. Again, as in the case of resistance measurements, we must always make certain that the capacitor under test is not connected in some other circuit which will give erroneous readings.

As previously stated, inductance measurements are made by means of conversion tables from readings on the capacity scales. The instrument set-up is exactly the same as for capacity measurements. In making measurements on this type of instrument, it is wise to take readings as near the center of the scale as possible. Readings here are more accurate than at the end of the scale.

In the preceding paragraphs we have discussed a typical Universal meter and its application. We do not claim that this type of instrument is the best type, but only use it for the purpose of explaining the fundamental principles of the Universal meter in general. It will be necessary for the service engineer to make his own decision as to what meter he intends to use. Basically, all instruments are much the same, differing only in ranges available, in the measurements which can be made, or in the method of switching. For example, some instruments, very good ones too, use push-button switches rather than rotary switches. Others use only two tip jacks and use a switch to change over for the various functions of the instrument.

4. OUTPUT METERS. As a rule, output is measured by means of an AC meter of the rectifying type, or a thermocouple meter. You have studied both of these meters and are acquainted with their operation. There is a third type of meter, or rather indicator, which has come into extensive use in recent years.

This type of instrument is shown schematically in Fig. 22A; a photograph is shown in Fig. 22B. This instrument operates on the principle that the glow of a neon tube depends upon the voltage applied. In other words, the higher the applied voltage, the brighter the glow. As seen in the diagram, a step-up transformer is connected across a control potentiometer, which, in turn, picks off the desired voltage and feeds it to the neon lamp.

To use this instrument, it is connected across the voice coil of the speaker in the receiver under test. The impedance of the speaker circuit and the voltage applied, determine the taps in the primary to be used. As it is difficult to notice a slight change in the glow of the neon lamp when it is bright, the lamp should be operated at the lowest noticeable brilliance.

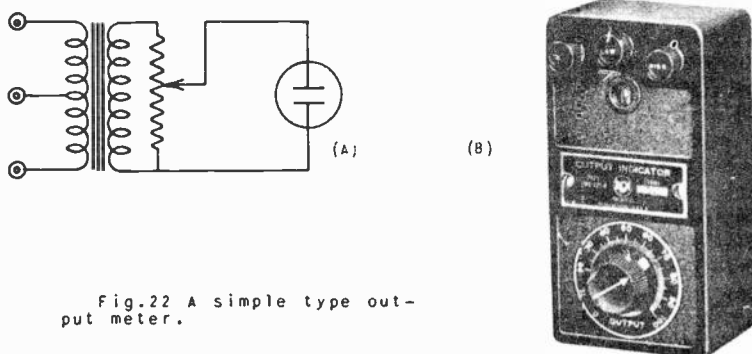

Fig.22 A simple type output meter.

This instrument is designed primarily for use in aligning receivers on service jobs where it is impossible to use cumbersome aligning equipment. Many times service jobs are completed in the customer's home, and at that time an instrument of this nature is very useful.

5. TUBE TESTERS. Another piece of equipment used quite extensively by service engineers is the tube tester. Actual experience has proved that nearly 75% of all radio receiver failures can be attributed to the failure in the tubes themselves. This is not due to faulty manufacture, but on the contrary, tube manufacturing processes have been brought to such a high state of perfection that we seldom hear of a defective tube in a new radio receiver. When we stop to consider that the average radio receiver is operated not less than 3 hours a day, we can see that the average life of 1,000 hours for a tube is passed within a year. This does not mean that all tubes can be a source of trouble after that period of time has elapsed.

The failure of radio tubes can usually be traced to the fact that the tube is worn out or has suffered abuse of one kind or another. It is very evident then, that one of the most important steps in radio receiver servicing is to be able to definitely find out the exact condition of the tubes in that set.

Inasmuch as the ability of a radio tube to operate normally is dependent upon its electrical characteristics, the best method to test a tube is by measuring those electrical characteristics and to compare them with the standard set up for that particular tube by the manufacturer. It is important to note that tubes whose characteristics are exceptionally high compared to the

standards are, in most cases, just as defective as tubes whose characteristics are low.

Due to limitations, it is not practical economically to make all tests which would give every electrical characteristic. These limitations make it unnecessary for the service engineer to have costly testing equipment. Since certain fundamental characteristics are fixed by the manufacturer, it is possible to make comparatively simple tests in order to determine the operating condition of a tube.

In commercial tube testers, the usual practice is to make measurements of a single characteristic of a tube. From this measurement, a tube is considered to be satisfactory or unsatisfactory. In deciding upon which characteristic is to be measured, it is, of course, necessary to select one which will give a definite picture of the overall condition of the tube.

Tube tester manufacturers use any of three tube testing methods. One, known as the emission test, is rather simple and inexpensive. The other two, known as the transconductance test and the power output test, are more elaborate, more accurate, and higher in cost.

In the following discussion, we will not attempt to say that one manufacturer's equipment is the best. Rather, we will present the advantages and disadvantages of each method. It is our opinion that if a service engineer understands the three different methods of testing tubes, he will be able to choose the type of tester which best fits his own requirements. After making his choice, he will know exactly what results he can obtain with the type of tester which he is using.

**EMISSION TESTS.** In all probability, the simplest method of indicating the condition of a tube is the emission test. If the emission of the filament or cathode is low, it is indicative of the end of the life of the tube. However, the emission test is subject to limitations, because it tests the tube under static conditions and does not take into account the actual operation of the tube.

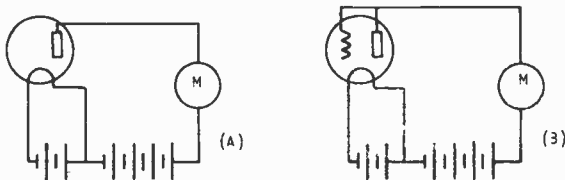

Fig. 2? Basic circuits for emission tests.

From our study of vacuum tubes in the earlier lessons of this course we know that if voltage is applied to the filament or heater of a vacuum tube, electrons are emitted. If the plate of the tube is made positive with respect to the filament or cathode, the electrons emitted will be drawn to the positively charged plate.

In order to attract all of the electrons emitted by the filament, it is only necessary to make the voltage applied to the plate sufficiently high. Under this condition, if a meter is placed in the plate circuit, the current flowing will be an indication of the electrons being emitted. By comparing this plate current to the published normal emission for the type of tube under test, the condition of the tube can be determined.

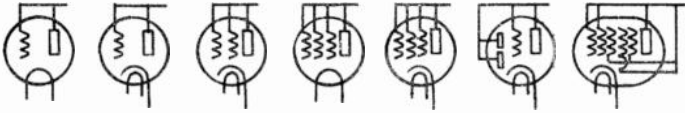

Fig. 24 Illustrating how the various elements of different tubes are connected together for emission tests.

Fig. 23 shows the basic circuit for the emission tests. If the tube is of the three-element type, then the grid and plate are connected together. Under this condition, electrons emitted by the filament are attracted to both the grid and plate, and the meter reads the total plate current. If the tube has more than one grid, all of the grids are connected to the plate, and as in the case of the triode, the meter will read the total of the plate current and all the grid currents.

Fig. 24 shows various types of tubes and how the elements are connected for the emission test.

Fig. 25 shows the connections for tubes having indirectly heated cathodes. The heaters marked HH are connected to an alternating current source. The cathode is connected to the negative side of the plate supply potential.

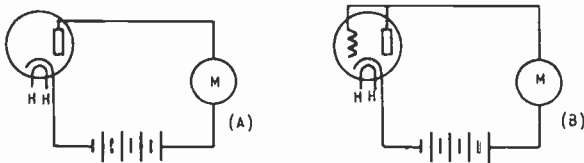

Fig. 25 Showing the connections for tubes with indirectly heated cathodes.

One precaution to be noted is that excessive voltage cannot be applied to the plate and grid in cathode type tubes, as excessive cathode current in a normal tube is likely to damage the cathode. For this reason, it is necessary in emission type testers to provide switching arrangements so that higher voltage may be used on some tubes and lower voltages on those tubes where there is danger of excessive cathode current.

Calibration of emission type testers is made from "experience" charts. A number of good tubes for each type are tested and the

plate current for each tube is recorded. The average of these readings is taken as a "good" indication for that particular type of tube. Additional tests are made on "fair" and "poor" tubes, and averages taken as before. All of these tests are made in the laboratory on equipment which tests these tubes in every possible way. From the above explanation, we can see that the more tubes that are checked in the laboratory, the better the calibration will be. A chart is prepared from the "experience" tables, and this chart is consulted whenever a test is made.

The chief advantages of the emission tester are its cheapness, its simplicity of construction and operation, and the speed with which tubes can be tested. Its operation is based on the fact that after the normal life of a tube, the electron emission begins to drop. This emission continues dropping until it is too low for practical use.

Regardless of what type of tester is used, it must be capable of making emission tests. The reason for this is that those tubes containing only one or more plates can be tested only by the emission test methods. Such tubes are rectifier tubes, and diode sections of duplex-diode tubes. This is true even though the tube tester may check other types of tubes by some other method.

There are many disadvantages of the emission type of tube tester, and the service engineer will have to decide whether the disadvantages outweigh the advantages.

An emission type tube tester indicates only that the total electron emission is either satisfactory or unsatisfactory. It does not indicate so-called active spots on the cathode. These active spots may have so great an emission that the small grid area adjacent to these spots cannot control the electron stream. Under these conditions, the total emission may indicate a "good" tube, while, actually it is unsatisfactory. If a tube has a very slight amount of gas ionized by the plate current, a resultant high plate current will be indicated, even though the actual emission may be low. The emission type tester will not give any evidence of elements in the tube having changed position due to abuse of one nature or another. For instance, a grid may change its position, thus affecting its ability to amplify satisfactorily, and still not affect the plate current flow. Also, the filament may have sagged, causing it to come close to the grid, affecting the operation of the tube but not its plate current.

Before discussing a typical Emission Type Tube Tester, there are two other causes of defective tubes to be considered. They are shorted elements, and indications of noise. Before testing a tube to determine its operating characteristics, it should be tested for short-circuited elements. As we automatically short the elements during tests in emission type testers, such a test is absolutely essential. If a short exists between the heater or filament and one of the other elements in the tube, it would easily burn out the meter in the tube tester due to excessive current.

It is desirable to maintain the filament or heater of the

tube at its correct operating temperature during the short-circuit test, because short-circuits in a tube may sometimes occur only when the electrodes are heated. One of the best methods of conducting a short test is to use a switch to disconnect the meter and connect in its place a small 6 volt lamp or neon bulb. By switching in the lamp before the meter is connected, excessive current due to shorted elements will be indicated by the lamp. The lamp remains dark if no elements are shorted.

The number of shorted elements that can be shown by the lamp depends entirely upon the design of the tester. Even though it may not be possible for the tube tester to indicate which of the two elements are shorted to each other, for all practical purposes that knowledge is not important. As long as the tube tester indicates definitely that there is a short somewhere, the tube should be discarded and the tester has served its purpose. The lamp is to indicate excessive plate current, regardless of which elements in the tube are short-circuited, and if the plate current is found to be normal, the rest of the tube test may be performed with the meter in the circuit.

The presence of noise ("crackling", humming, etc.) in a tube is one of the chief causes of trouble to the average radio listener. The peculiar nature of many of these noises make it impossible to detect them on making the normal tests usually included in tube testers.

Tube noises, even though they may not cause trouble in some circuits, can be extremely annoying in other circuits. For example, tubes used as microphone amplifiers in speech input equipment must be exceptionally free from noise. The reason for this can be easily understood. The amplification between the microphone and the modulation amplifier in the average transmitter amounts to many thousand times the signal available at the microphone. Now, if there is any noise in the tubes in the pre-amplifier, it will be amplified to the same extent as the signal from the microphone itself. Low tube noise is also important in such equipment as public address systems, and even in the first stages of a radio receiver. For this reason, it is important that some method be provided in the tube tester to make a noise test that is reliable.

Fig. 26 shows the schematic diagram of an emission type tube tester capable of testing any type of radio tube. A photograph is shown in Fig. 27. This unit is designed to test any radio receiving tube now made and is capable of testing any new type tube which may come in the future. It also provides means for testing pilot lamps, flash light bulbs, and Xmas tree lamps. Provisions are also made for short tests and noise tests.

All essential operating information is placed on an adjustable roll. Suitable guide lines to the individual push buttons and controls make it impossible to make errors in testing. Push buttons are used to connect the various elements into the circuit for testing. A control is located in the primary circuit to permit adjustment for varying line voltage conditions. With this control, line voltages from 100 to 125 volts may be used with





exactly the same results. This control is known as the line volts control.

The filament voltage for the various tubes is adjusted by means of a tap switch connected in the power transformer secondary. Provision is made to test tubes with filament voltages of from 1.1 volt to 120 volts. The power for the plate circuit in this tester is obtained from a 6J5G tube connected as a rectifier. Taps on the power transformer secondary provide for general adjustment for different plate potentials, and a potentiometer gives a fine adjustment of this potential. A six section range switch is used to give the correct interconnection of the tube elements. Noise tests are made through a pair of headphones inserted in the jack provided. Short tests are made with a neon bulb placed in the circuit and connected through the "Short" Switch.

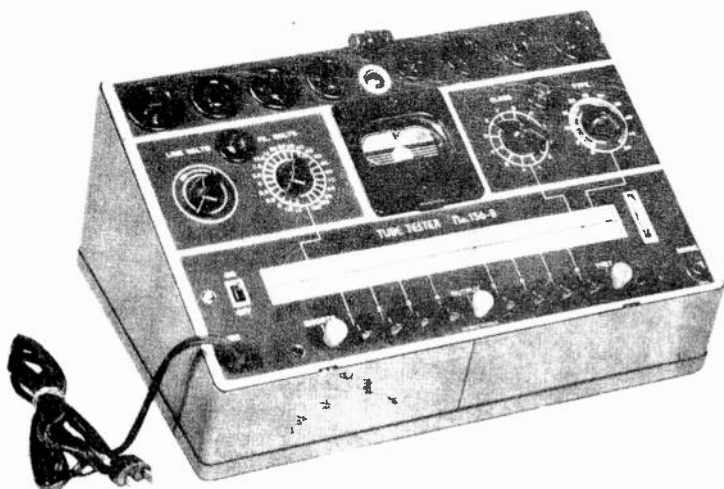

Fig. 27 Photograph of the tester whose diagram is shown in Fig. 26. (Courtesy, RCA Mfg. Co.)

To further explain how this particular instrument operates, let us take a typical tube and see what takes place in the circuit while it is being tested. Any type tube will do, but for simplicity, let us use the 6C5.

The instrument is first connected to a source of power and the "On-Off" switch is thrown to the "On" position. By means of the line voltage control, the line voltage is adjusted until the meter reads at the "Line Check" position. We now rotate the chart until we find the 6C5 type of tube, and set the "Fil Volts", the "Class", and the "Type" controls as indicated by the rotations of the respective columns on the chart. To insure proper setting, it is wise to follow the guide lines from the chart to the control knobs. In the case of the 6C5, we find that the "Fil Volts" control should be set at 6.3 volts, the "Class" control at "A", and the "Type" control at "31". We are now ready for the test, and

the tube to be tested is inserted in the proper socket; in this case, the octal.

The first test to be made is the short test to determine if there are any shorts between elements in the tube. By pushing the "Shorts" button, all other buttons are released. We next push buttons numbers 1 to 8 in consecutive order. If the neon tube glows steadily on any test, a short-circuit is indicated and the tube should be discarded. On some tubes, the neon lamp should glow when certain buttons are depressed as indicated on the chart by the word "Shorts" opposite those buttons.

Looking at the circuit diagram (Fig. 26), let us follow the circuit diagram for the short test. When the switch is pressed, all other buttons are released. When button number 1 is pressed, we find that contact number 8 of the octal socket which is connected to push-button number 1 through the switch (Section 6) is now connected to the lower common connections. From here the circuit goes through the test switch to one side of the neon lamp. All other elements of the tube under test are connected through the gang switch and the push-button switch to the top common connection and then to ground. One side of the power transformer is also connected to ground. The 110 volt tap of the transformer is connected to the other side of the neon bulb. Now if a short exists in the tube under test, there will be a completed circuit and the neon bulb will light. When button number 2 is pressed, it is connected to the bottom common connection as well as button number 1. Each element in the tube can be traced through in a similar manner.

Assuming that no shorted elements have been found, we now are ready to proceed with the emission test. The "Test" button is pressed, which releases all other buttons, and locks itself in place. We then look at the chart and press the buttons as specified. In the case of the 6C5, these will be buttons numbers 3 and 5. Before proceeding, it is wise to check the line voltage again, and if necessary, make any adjustments required to bring the pointer to the "Line Check" position. We finally press the output button and observe the condition of the tube by the indication on the meter. As a rule, tube testers have the indicating dial divided into "Good" and "Poor" scales, or into "Good", "Poor", and "Bad". This speeds up the readings, as it is only necessary to glance at the meter to determine the condition of the tube.

In the case of multiple purpose tubes, such as the 1A6, more than one test is required. One test is required each for the oscillator section and one for the converter section. These multiple tests are given in the correct sequence on the charts.

Noise tests are made with this instrument by inserting a pair of headphones into the noise jack marked J-1 on the schematic diagram in Fig. 26. Examining this circuit, we see that when the phone plug is inserted in the jack, the phones are placed in series with the rectifier circuit which supplies plate voltage to the tube under test.

When the tube is tapped lightly, any shorting of elements within the tube, or any great change of the internal characteristics within the tube will cause a sudden change in plate current. This change in plate current will cause an erratic response in the headphones, which are in series with the plate supply circuit, indicating that the tube under test is defective. At this point, it would be wise to call attention to the so-called "microphonic" effect. The elements of a tube are of such a nature that they cannot be supported so that some vibration does not take place when the tube is shaken or tapped. Consequently, as these elements vibrate under some outside influence, such as the tapping of the side of the tube, they set up a "howl" in the headphones. This howl is sometimes called the microphonic effect, as it corresponds to the action of a microphone in converting mechanical motion into electrical impulses in much the same manner as a microphone. Unless this microphonic effect is prolonged or exceptionally strong, it can be ignored when making noise tests.

If any doubt exists after making all these tests, it is sometimes wise to repeat the test for shorted elements. Once in a while, excessive leakage or shorts do not show up until after the tube has heated for a longer period of time.

**TRANSCONDUCTANCE TESTERS.** Transconductance, or mutual conductance as it is sometimes known, was defined and described completely in Unit 1. However, we feel it advisable to repeat a part of that information at this point. Transconductance of a tube is usually expressed by the symbol  $S_m$ , and is defined as the change in plate current divided by the change in grid voltage causing the plate current change, with the plate voltage held constant. A tube functions as an amplifier because a change in grid voltage causes a change in plate current. The greater the change in plate current caused by a given change in grid voltage, the better the tube is as an amplifier or detector, other tube constants remaining the same.

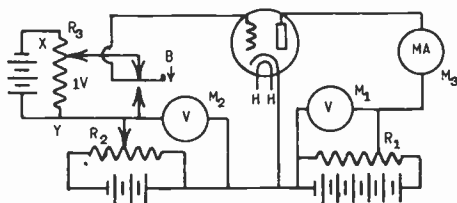

Fig. 28 Fundamental circuit of a transconductance tube tester.

Since the amplifying property of a tube depends upon how much plate current change is caused by a given grid voltage change, by comparing these values we obtain a degree of merit known as transconductance. Since conductance is the opposite of resistance, it is expressed in "mhos". "Mho" is ohm spelled backward.

Because the transconductance of a tube is going to be gained by producing a grid voltage change, this type of testing is often known as the "grid shift" method of testing. There are two forms

of transconductance tests which can be utilized in a tube tester. Fig. 28 gives the fundamental circuit for the first type. Appropriate operating voltages are applied to the electrodes of the tube. A plate current, depending upon these voltages, will be indicated by the milliammeter  $M_3$ . If the bias on the grid is then shifted by the application of a different grid voltage, a new plate current reading is obtained. The difference between the two plate current readings is indicative of the transconductance of the tube. The readings obtained under these conditions are called "static" readings.

In considering the fundamental circuit shown in Fig. 28, the potentiometer  $R_1$  is adjusted so that the correct plate voltage is applied to the tube under test. With the button B in the "Up" position, the potentiometer  $R_3$  is adjusted so that exactly one volt drop exists between points X and Y. When this condition exists, potentiometer  $R_3$  need not be adjusted until the battery changes voltage. The potentiometer  $R_2$  is then adjusted so that the grid voltage applied to the tube is normal. This voltage is measured by the voltmeter  $M_2$ . The plate current under these conditions is then read. Now, pushing button B in a downward direction, the negative grid voltage applied to the tube is reduced 1 volt. This will cause an increase in plate current as read on meter  $M_3$ . The difference between these two plate current readings (in amperes) divided by the 1 volt grid voltage change, will give the transconductance of the tube under test.

The plate impedance and amplification factor of a vacuum tube are quite important; however, since the transconductance of a tube is controlled by the ratio of these two constants, any change in either is bound to affect the mutual conductance. Therefore, if the transconductance of a tube is found to be normal, it indicates that both the plate impedance and amplification factor are also normal, so these need not be tested separately. While the transconductance is not a complete indication of the comparative merits of tubes of different types, it is a positive indication of merit among tubes of the same type.

Transconductance is measured in mhos; but the transconductance of a tube is so small that the mho is usually expressed in one-millionth part of a mho, or "micromhos". This is the unit universally employed for the  $S_m$  of radio tubes. To convert mhos into micromhos, simply move the decimal point six places to the right; that is, multiply by 1,000,000.

In calculating the transconductance of a tube, you must remember that the plate current is in amperes and the grid voltage in volts. As an example, let us assume that we have a plate current change of 3.4 ma. produced by a grid voltage change of 1 volt. Substituting these values in our formula, we have:

$$S_m = \frac{.0034}{1} = .0034 \text{ Mho, or } 3400 \text{ Micromhos}$$

While the transconductance testing arrangement shown in Fig. 28 is satisfactory for actual tube testing, it cannot be consid-

ered completely satisfactory for the rapid testing of tubes, due to the fact that a computation is required for each test.

If an arrangement is provided whereby the grid voltage is varied every time by a definite, fixed amount for each type of tube, all we need to notice is how much plate current change is produced by this grid voltage change. Such a circuit arrangement is shown in Fig. 29. Plate current flowing through the cathode resistors  $R_1$  and  $R_2$  produces a voltage drop which is applied to the grid of the tube, and the value of which is determined by the position of switch S. A special chart is prepared, giving the plate current change limit obtained for known "good", "fair", and "poor" tubes which have actually been tested. The plate current meter M is then usually marked off in "good", "fair", and "poor" divisions instead of in actual milliamperes. Some commercial tube testers actually employ this method.

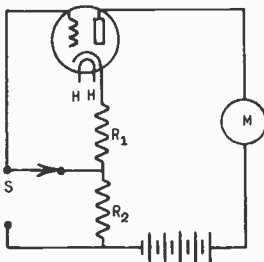

Fig.29 A circuit in which the grid voltage is changed a definite and fixed amount for all tubes.

Since it is desirable to operate tube testers directly from the AC supply line, slight changes in the circuit design are effected in order to accomplish the same purpose.

The circuit shown in Fig. 29 may be operated directly from the AC supply by using a suitable step-down transformer to supply the filament or heater voltage. Such a transformer and its associated circuit is shown in Fig. 30. All of the tube sockets of

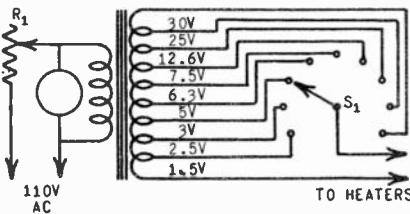
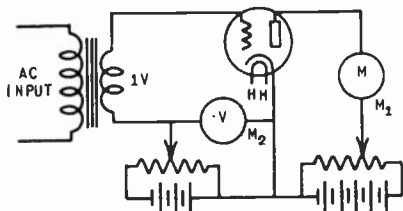

Fig.30 A filament transformer for a tube tester.

the tube tester have their heater or filament windings in parallel. The correct voltage according to the tube being tested is selected by switch  $S_1$ . Rheostat  $R_1$  is varied so that the voltmeter V reads 110 volts. In place of the B battery shown in Fig. 29, one terminal of the meter is connected directly to the 110 volt AC line and the lower end of resistance  $R_2$  is connected to the other side of the AC line. The tube under test then acts as

a half-wave rectifier and meter M reads the average value of plate current. No current flows on the negative half of the AC cycle, but still the tube will function nearly as satisfactorily as though pure DC were used.

Fig. 31 Illustrating how a dynamic transconductance test is made.



All of the tests to date have been made under static conditions. A dynamic transconductance test method is shown in Fig. 31. This is superior to the static transconductance test in that an AC voltage is supplied to the grid. Thus, the tube is tested under conditions which approximate actual operating conditions. The alternating component of the plate current is read by means of an AC ammeter of the dynamometer type. The transconductance of the tube is equal to the AC plate current divided by the input signal voltage. If a 1-volt RMS signal is applied to the grid, the plate current reading in milliamperes divided by 1,000 is the value of transconductance in micromhos.

The presence of gas in a tube may often be sufficient to completely upset the stable operating condition of that stage of amplification in which the tube is stationed. Under these circumstances, some means of determining the presence of gas is a necessity in a good tube tester.

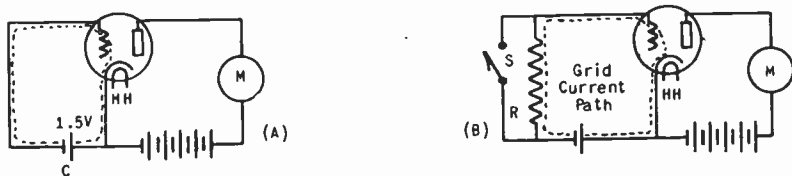

Fig. 32 Illustrating the fundamental gas-testing circuit.

A very simple test is usually included in commercial testers for indicating the presence of even a minute quantity of gas. This test is dependent upon the fact that when a tube is operating at zero bias or a slightly negative bias, it should have no grid current flowing. To further explain this gas test, let us examine Fig. 32A. In this circuit, the plate current measured by meter M will depend upon the type of tube, and the voltages applied. If a bias voltage of 1.5 volts is applied by using a "C" battery, and if no gas is present in the tube, no grid current will flow. Now, let us examine the circuit shown in Fig. 32B. This circuit is

identical with the circuit shown in Fig. 32A, except that a resistance of from 0.5 to 1 megohm, shunted by a shorting switch, is placed in the grid circuit.

If the switch is open, and grid current is flowing, a voltage is developed across the resistor, which changes the bias voltage on the tube, and in turn will affect the plate current as indicated by the meter M. When the shorting switch is closed, the effect of the resistor is eliminated, the bias voltage is normal, and the plate current returns to its normal value. In actual tests, if opening and closing the shorting switch shows no change in plate current, the tube is satisfactory. However, if there is an appreciable change in plate current when the shorting switch is opened and closed, gas is present in the tube under test and the tube should be discarded.

Now let us look into the question of leakage between cathode and heater in those tubes which employ the indirectly heated cathode. In this type of tube, the cathode must be insulated from the heater, as in many cases, there may be as much as 100 volts potential difference between these two elements. If there is a breakdown in the insulation at this point due to the high potential difference, it may result in a noisy tube. A simple method of testing for such a defect is shown in schematic form in Fig. 33. In this circuit, you will note that a meter is placed in the plate circuit, and a switch in the cathode circuit. By observing the meter reading with the switch in both the open and

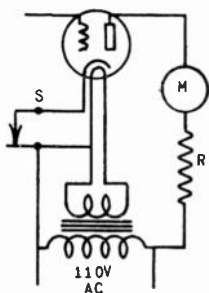

Fig. 33 A simple leakage tester.

closed positions, an indication of the presence of leakage is obtained. Examining the circuit in Fig. 33, we find that the heater voltage is supplied through a filament transformer. The plate voltage for the tube is obtained from the 110 volt line through a current limiting resistor and a meter. The other side of the 110 volt line is connected to one side of the heater and also to the cathode through a switch. With the switch closed, the meter will read the average of the pulsating current flowing, due to the rectifying action of the tube under test. If the switch is opened, the cathode is disconnected from the circuit and the plate current should immediately drop to zero, as indicated by the meter.



If no leakage exists between cathode and heater, this condition will hold true. However, if there has been a breakdown in the insulation between these two elements, even though the cathode switch is in the open position, a current flow will still be present and will be indicated on the meter. The extent of the leakage will depend on the amount of current flowing when the switch is in the open position. That is, if the plate current is the same for both the open and closed position of the switch, the insulation between cathode and heater has been broken down completely and there is a direct short.

Fig. 34 shows a picture of a typical transconductance meter. Rectified current is used to energize all elements except heaters. An AC voltage is superimposed on the grid circuit, thereby permitting a "dynamic mutual conductance" test. In twin and multi-element tubes, the components are tested separately, determining the "dynamic mutual conductance" of each component. In twin-grid tubes, each grid is energized separately, determining the relative function of each. Diode and rectifier plates are tested separately.

Separate "gas" and "short" tests are available. The short test may be made while the tube is either hot or cold. All readings are made on an edgewise meter scale.

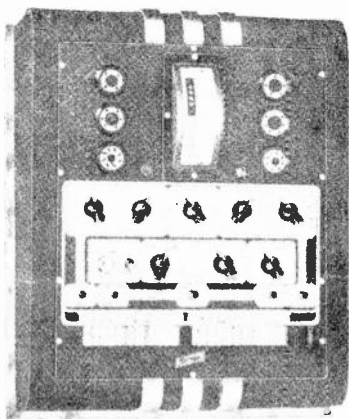

Fig. 34 Photograph of a dynamic mutual conductance tester. (Courtesy, Hickok Electrical Instrument Co.)

6. POWER OUTPUT TESTERS. Fig. 35 shows the fundamental circuit diagram of a power output tester for Class A operation of tubes. This particular diagram illustrates the method used for testing a pentode. Proper DC voltages are applied to all elements of the tube (the heater is AC), then a definite AC voltage is superimposed on the DC grid voltage. The AC output voltage developed across the plate load impedance  $L$  is then read on the AC meter. The current meter is isolated from the DC plate current by condenser  $C$ . The power output can then be calculated from the current reading and known load resistance. In this way, it is



tube is kept from reaching the rectifier by a .5 mfd. blocking condenser.

The correct positive plate and screen voltages applied to the tube are selected by the rotary switch marked "tube selector". The fixed grid bias voltage is controlled by the potentiometer marked "Load 2". A line voltage control is provided with a separate AC line-voltage meter.

The correct testing procedure is to set the "filament voltage" switch on the correct position, place the tube in the proper socket, then test the tube for shorts. Following that, the "tube selector" switch is set on the proper position, "Load 1" and "Load 2" are adjusted to the positions specified and the "value" button depressed. A "good" or "bad" tube will be read directly on the meter. The correct positions of "Load 1", "Load 2", and "Tube Selector" for each type tube are supplied on a chart with the tester.

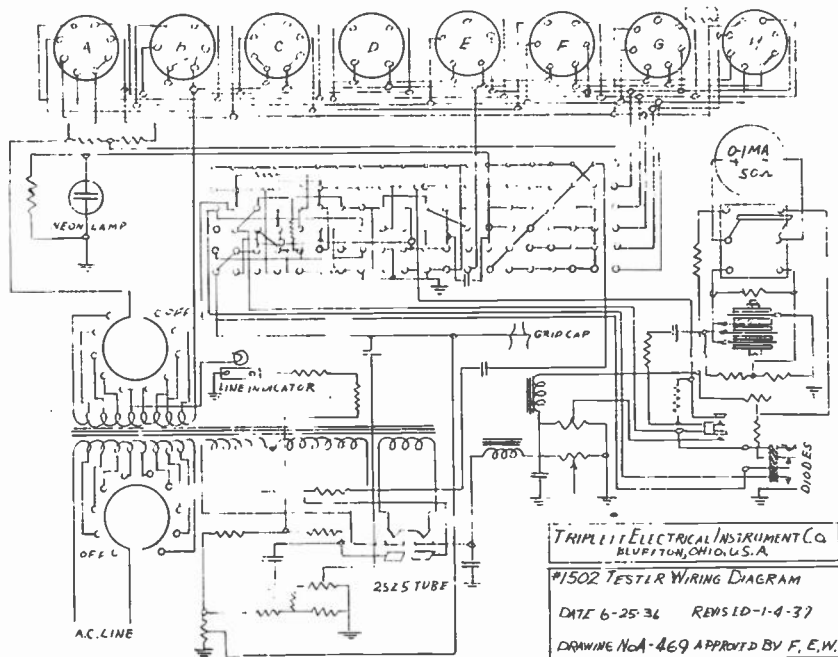

Fig. 36 Schematic wiring diagram of a power output tube tester.

Special provisions have been made for testing the diode plates of multi-element tubes and both plates of rectifier tubes. With this same arrangement, it is possible to test both the emission and amplification factor of all tubes. The emission tests should be made first, followed by the regular power output test.

A sensitive "short" test indicator is supplied with this instrument. After the tube has an opportunity to become thorough-

ly heated, the tube selector switch is rotated through the S-H-O-R-T-S positions. The tube should be tapped in each position to make certain that possible shorts will not develop. A neon tube is employed to indicate a shorted condition. When the neon tube glows, a short is indicated. A flash when moving between positions indicates a condenser discharge within the tester and not a shorted tube. The neon tube will either flash rapidly, or the glow will be steady on a shorted tube. The degree of the short will be determined by the brilliancy of the glow.

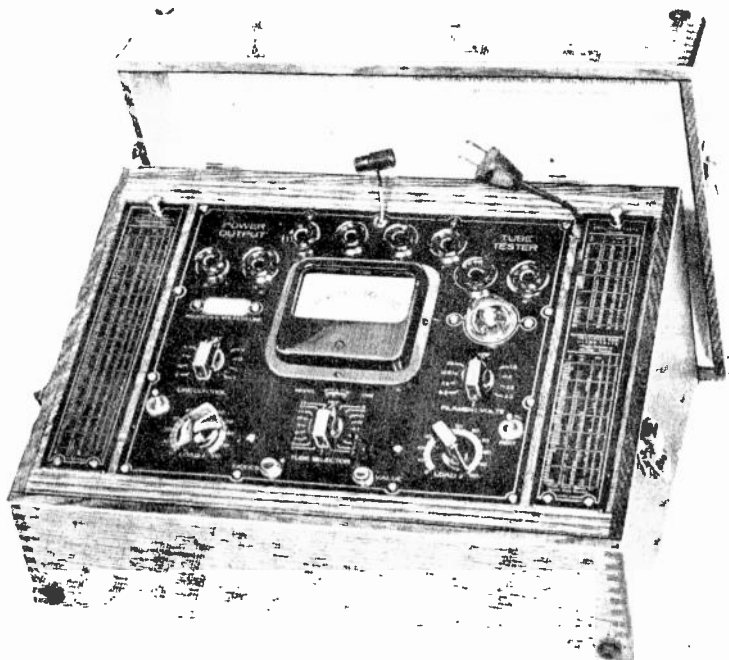

Fig. 37. Photograph of power output tube tester whose wiring diagram is shown in Fig. 36. (Courtesy Triplett Electrical Instrument Co.)

7. RECEIVER ANALYZERS. Later in this series of lessons you will learn that voltage and current measurements must be made on a tube while in operation in a receiver, so as to definitely isolate trouble. In old type receivers, which were constructed with all the tube sockets and parts mounted on an open baseboard, the measurement of these voltages and currents was comparatively easy. In the modern receiver, the tube sockets, resistors, and condensers are all mounted underneath the chassis. In many cases, even with the chassis removed from the cabinet, all the parts are not accessible for easy measurements.

It is possible to make all voltage and current measurements in a very simple manner. It is only necessary to bring the circuits out, by means of an extension cord, to an external socket

and make the necessary measurements at that point. These circuits are generally extended by the use of an analyzer plug which has the same number of contacts as the socket from which the tube has been removed. Each contact in the plug is connected, by means of separate conductors assembled into a cable to a similar socket in which the tube taken from the receiver is placed.

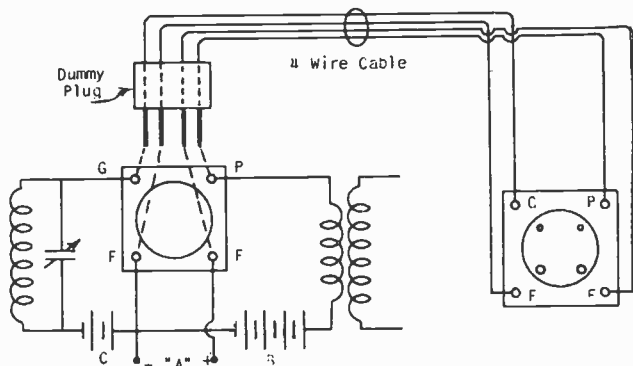

Fig. 38 Fundamental circuit of a set analyzer.

The method of bringing out the circuits by means of a plug and cable to an external socket is shown in Fig. 38. In this case, the simplest form of three-element, four-prong tube is shown. The plug is shown over the top view of the socket ready to be inserted after the tube has been removed. The tube removed from the socket in the radio receiver is then placed in the external socket at the other end of the four-wire cable. As all the circuits are identical at the external socket, we can measure the voltages at the external socket. Using this method, it is not necessary to remove the radio receiver chassis from the cabinet to obtain readings.

The above outline of the method of extending the circuits of the receiver illustrates the fundamental principle of all set analyzers. It follows, of course, that the number of prongs of the plug and in the external socket must be the same as on the tube to be analyzed. For instance, if a seven-prong tube is to be analyzed, a seven-prong analyzer plug and a seven-prong external socket must be used. Naturally, it would be very unhandy to carry around a set of plugs, cables, and sockets, one each for four-prong, five-prong, etc. tubes. It then appears that the most convenient form would be to combine all the different sockets in one panel together with the necessary meters for testing and any switching arrangement which may be required. This is exactly what we have in the commercial "set analyzer". The purpose of a set analyzer, then, is to allow the extension of the tube circuits to a more convenient position where any measurement may easily be made. With the analyzer, it is unnecessary to make measurements

in cramped quarters often found in radio receivers. It is also unnecessary to remove the receiver chassis from the cabinet. To make the voltage and current measurements required, it is only necessary to place the analyzer at some point convenient to the receiver chassis, remove the tubes one at a time, and place them in their proper sockets in the analyzer. As stated previously, it is necessary to have a socket in the analyzer for every tube to be found in any radio receiver. In other words, a 4, 5, 6, 7, and 8-prong socket are required. In turn, the cable between the analyzer and the analyzer plug must have sufficient leads to care for the greatest number of contacts, namely eight. Now, using one cable, some means of adapting the eight leads in the cable to sockets of 4, 5, 6, and 7 prongs must be provided. This is usually accomplished in the following manner. The cable is fitted with an eight-prong plug, which is designated to fit an octal socket.

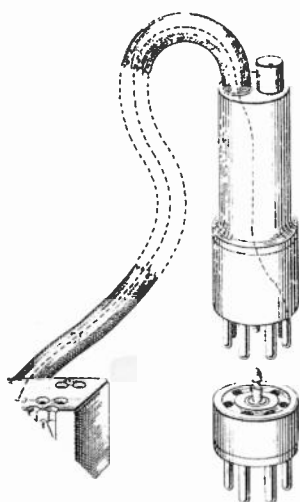

Fig.39 The analyzer plug and socket adapter.

Courtesy "Weston Electrical Instrument Co."

In addition, several adaptors are furnished, all fitted with an octal female section, but the male section on each one is for a different socket. There is one furnished to fit a four-prong socket, another to fit a five-prong socket, another for a six, and also one to fit a seven-prong socket. Fig. 39 shows how the plug on the analyzer cable is fitted in the adaptor plug.

When an octal tube is to be analyzed, it is only necessary to use the plug on the analyzer cable without an adapter.

Having brought the tube circuits to an external socket, our next consideration is some simple method of making measurements. Fundamentally, we are interested in the plate, grid, and filament voltages, and the plate current. Fig. 40 shows the same circuit as Fig. 38 with the necessary meters inserted in the circuit. This arrangement is the basic principle of measurement in analyzers. Of course, such an arrangement would not be practical in commercial instruments. In the first place, the mass of instru-

ments required would be out of all reason. Also, all the measurements necessary can be made with a single instrument by means of a simple switching arrangement. Fig. 41 shows just such a circuit.

We have not included any series or shunt resistors in this circuit for changing the scale readings of the meter, in order to keep the circuit as simple as possible. However, your studies in the earlier parts of this lesson will enable you to understand just where these resistors are required.

From this point it is only a step to the complete analyzer of several sockets, for the various type tube bases, a meter (usually an 0-1 milliammeter), a rectifier element for AC measurements, a cable and several adapters, and most important, switches for changing the metering circuits.

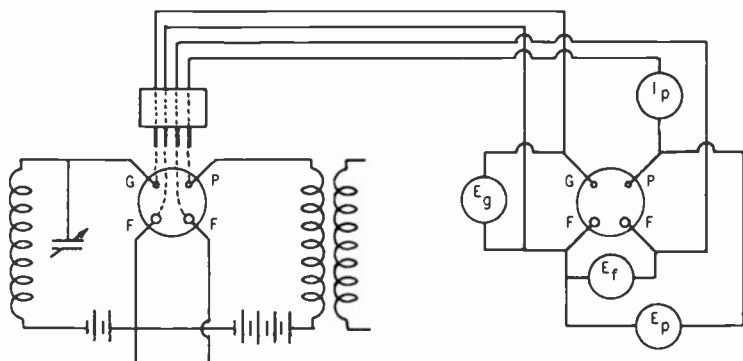

Fig. 40 Illustrating how measurements are made using a set analyzer.

This type of set analyzer was very popular in the early days of radio. At that time, there were very few tubes available for use in radio receivers, and the tube circuits were so standardized that we could, with very little trouble, arrange the analyzer circuits to make any measurement desired. However, with the advent of modern receivers and the development of better than 400 new tubes for radio receivers, it was found necessary to develop a new type analyzer. It was necessary to find a simple yet convenient method of making the necessary tests and measurements on tubes under actual operating conditions. By examining a chart of tube base connections (such as shown in one of the Unit 1 lessons), it is obvious that an analyzer with sufficient switching arrangements to care for all of these circuit combinations would be nothing short of a laboratory instrument.

Since the switching arrangement is the limiting factor in an analyzer for modern receivers, they have done away with circuit switching, and the so-called "free point" analyzer is the result. In effect, a "free point" analyzer employs a pin jack system for connecting the required meter in the various circuits of a tube. A sketch showing the fundamental idea of a "free point" analyzer is shown in Fig. 42. Let us assume that the tube has been removed

from its socket in the receiver and placed in its proper socket in the analyzer. The dummy plug is then placed in the correct adaptor with the proper number of prongs to fit the socket from which we removed the tube in the receiver. From each of the contacts on the tube socket in the analyzer, a wire connects to a pin jack on the analyzer panel. Also, a wire runs from each prong on the plug at the end of the cable to a pin jack on the analyzer panel. If a test prod is not inserted in either of the two jacks between the tube socket and the corresponding wire in the analyzer cable, a normal through connection exists. If a prod is inserted in one of the pin jacks, it disconnects that section of the circuit.

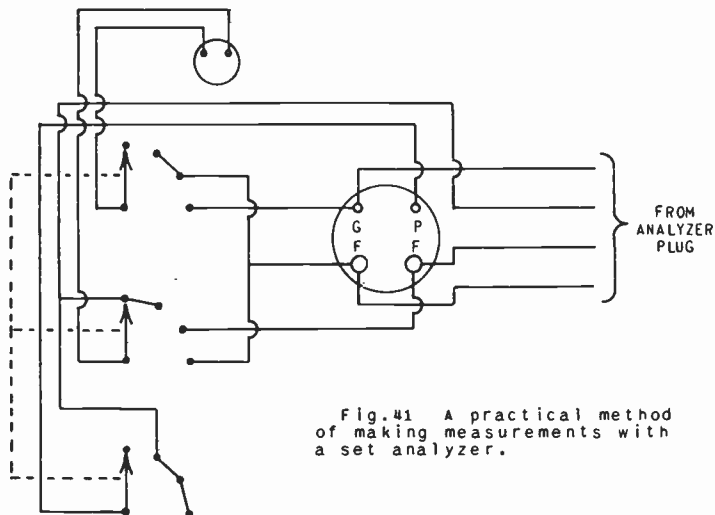

Fig. 41 A practical method of making measurements with a set analyzer.

In this particular set-up, a single meter is used, and various ranges are selected by means of a range switch. The two leads from the meter are brought to the top of the panel and connected to suitable test prods. By inserting these two test prods in any two pin jacks, it is possible to measure the voltage between any two points in the tube circuit. Also, the current in any circuit may be measured by inserting the meter test prods in the two pin jacks leading to that particular circuit. As explained above, when the meter prods are inserted in the pair of pin jacks for current measurements, one of the contacts is automatically opened, thereby breaking the normally completed circuit between these two jacks. The meter itself then completes the circuit; that is, it will be connected in series to make the current measurement.

The above illustration is given not as a representative free point tester, but as the fundamental principle around which free point testers are built. The main advantage of a free point tester lies in its extreme flexibility. Regardless of the newer types of tubes which may be brought out, or the newer circuit



designs in which these tubes may be employed, each of them can still be completely checked, using this system. It is only necessary to provide for a sufficient number of sockets, leads, and adaptors in the initial design of the free point testing unit. Thereafter, it is unlikely that the instrument will ever become obsolete. At the present time, all of the newer tubes being placed on the commercial market for radio purposes have an octal base which fits into a universal octal socket. If the free point tester is provided with a four, five, six, seven, and eight-prong socket, together with a sufficient number of leads and adaptors, it will accommodate all present radio tubes and possibly all of those which will emerge from laboratories for quite some time to come. Considering the present status of radio tube design, it is doubtful if more than eight prongs will be used in the immediate future; therefore, when the service engineer purchases an instrument capable of completely analyzing these tube's circuits, he may feel certain that his instrument will not become obsolete during its normal life.

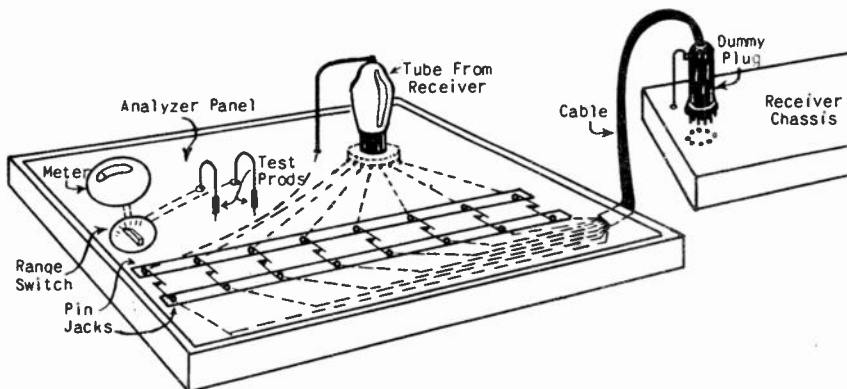

Fig. 42 Fundamental circuit of a free-point analyzer.

In order to prevent the possible errors which may arise from inserting the meter test prods in the wrong pin jacks, the manufacturers of such equipment supply a detailed description of the method of free point testing with each piece of equipment sold, together with a tube base chart. After using a free point tester for a short period of time, one should become very proficient in analyzing a tube's circuits.

Fig. 43 shows a typical diagram of a commercial free point tester. It is usable with all types of tubes, either metal or glass, regardless of the number of prongs. It is equipped with five sockets. The pin jacks, which are of the automatic switch type, are connected to correspondingly numbered contacts on the various tube sockets. This unit is designed for use with a volt-ohm-milliammeter. It is only necessary that the volt-ohm-milliam-

meter have sufficient volt and milliammeter ranges to take care of all requirements. Adaptors are also provided, but are not shown in the diagram. The adaptors, in this particular case, are wired so that on the four-prong adaptor, tip jacks numbered 1 to 4 are the only ones used; similarly the five-prong adaptor is wired to tip jacks numbered 1 to 5.

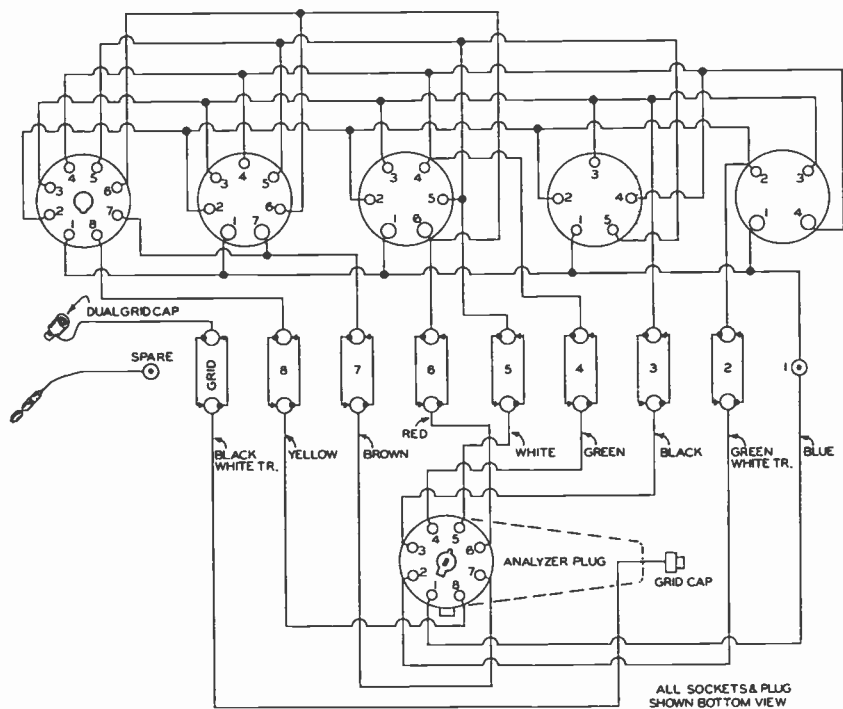

Fig. 43 A commercial free-point analyzer.

Before proceeding with an explanation of the use of this instrument, it will assist you to explain that all modern set analyzers use the RMA tube pin numbering system. In this system, as seen from the top of the socket, each contact is numbered consecutively in a clockwise direction. Fig. 44A shows a top view of a standard 8-pin octal socket, and Fig. 44B shows a bottom view of the same.

At this time, it is necessary to point out a very important fact pertaining to the use of a free point tester. In all cases when analyzing a tube circuit with an instrument of this kind, the tube base connections must be considered from the top of the socket, rather than from the bottom. In many previous explanations, especially those pertaining to your laboratory work, the tube base connections have been given with reference to a bottom socket view. It will now be necessary for the student to visual-

ize these connections from the top of the socket, rather than from the bottom. In other words, the tube base connections will be exactly opposite from all previous information. In a lesson of Unit 1, the socket connections for most present tubes were illustrated. In the RCA receiving tube manual, all of the socket connections are shown as viewed from the *bottom* of the socket. Bear in mind that in all free point testing work, you must consider the tube connections from the *top* of the socket. A rather complete tube chart is shown on the next three pages of this lesson. It is advisable to keep these charts handy at all times when working with the free point tester.

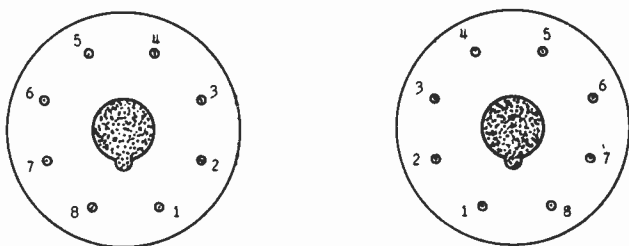

Fig. 44 (A) Top view, and (B) bottom view, of an octal socket.

Now let us illustrate how the free point tester may be used to make voltage and current measurements on an amplifying tube, such as a type 58. First of all, the type 58 tube would be removed from the chassis of the radio receiver and inserted in the six-prong socket on the free point tester unit. Then the six-prong adaptor is placed on the dummy plug at the end of the analyzer cable and the plug, with adaptor attached, is inserted into the receiver chassis socket from which the 58 tube was removed. The grid clip which was formerly connected to the top cap on the 58 tube in the chassis, is to be connected to the grid clip on the analyzer plug. The grid clip wire on the free point tester panel is then attached to the top cap on the type 58 tube. With the receiver turned on, the type 58 tube will have its normal voltages applied while it is in the free point tester. The heater of the tube should glow, and, unless the lengthened circuit leads cause oscillations or other undesirable effects, the radio set should be performing in the same manner as with the 58 tube inserted in the amplifier socket.

Now that the type 58 tube is inserted in the free point tester and all connections properly made, it is possible to completely analyze the voltages applied and currents flowing in its circuits by plugging the test leads from a measuring instrument into the proper pin jacks. In this particular analyzer, either pin jack may be used for the voltage measurements, but when current measurements are made, it can be seen that both automatic switches are opened and the circuit is closed only through the milliammeter.

# TUBE BASE CHART

Tube	Base	Tube	Base	Tube	Base	Tube	Base	Tube	Base	Tube	Base
00	4D	37	5A	68A	5E	402	4*	E	4D	2Y3	4C
00A	4D	37A	5A	69	6N	403	4*	G	4D	2Y4	5D
01	4D	38	5F	70	6N	482A	4D	GA	5B	2Z2	4B
01A	4D	38A	5F	71	4D	482B	4D	G2	5D	5Z3	4C
01AA	4D	39	5F	71A	4D	483	4D	G2S	5D	6A3	4D
01B	4D	39A	5F	71B	4D	484	5A	G4	5D	6A4	5B
1	4G	40	4D	75	6G	485	5A	G4S	5D	6A6	7B
1V	4G	41	6B	75S	6G	486	5†	G84	4B	6A7	7C
2	4A	42	6B	76	5A	585	4D	H	4D	6A7S	7C
2S	5D	43	6B	77	6F	586	4D	HZ50	4G	6B5	6D
3	4A	44	5F	78	6F	840	5J	K24	5E	6B7	7D
4	4A	45	4D	79	6H	841	4D	K27	5A	6B7S	7D
4S	5D	46	5C	80	4C	842	4D	KR1	4G	6C6	6F
5	4A	46A1	5*	80M	4C	843	5A	KR2	4G	6C7	7G
6	4A	46B1	5*	81	4B	P861	5D	KR5	5B	6D6	6F
7	4A	47	5B	81M	4B	864	4D	KR20	6N	6D7	7H
8	4A	48	6A	82	4C	866	4P	KR22	6N	6E5	6R
9	4A	49	5C	82V	4L	874	4H	KR25	6B	6E6	7B
10	4D	50	4D	83	4C	876	SB	KR28	5D	6E7	7H
12	4D	51	5E	83V	4L	879	4P	KR31	4G	6F7	7E
12A	4D	51S	5E	84	5D	886	SB	KR98	5D	6F7S	7E
14	5E	52	5C	85	6G	950	5B	LA	5B	6G7	7N
15	5F	53	7B	85S	6G	951	4K	PZ	5B	6H7	7P
17	5A	55	6G	88	4C	952	4N	PZH	6B	6Y5	6J
18	6B	55S	6G	89	6F	985	5D	RA1	4D	6Y5V	6J
19	6C	56	5A	90	6N	986	4C	RE1	4C	6Y5S	6J
20	4D	56A	5A	91	6N	AD	4G	RE2	4B	6Z3	4G
22	4K	56AS	5A	92	6N	AF	4C	SO1	4D	6Z4	5D
24	5E	56S	5A	95	6B	AG	4C	SO2	4D	6Z5	6K
24S	5E	57	6F	96	4G	AX	4D	WD11	4F	12A5	7F
25	6M	57A	6F	98	5D	A22	4D	WX12	4D	12A7	7K
25S	6M	57AS	6F	(V)99	4E	AC22	5E	1A4	4K	12Z3	4G
26	4D	57S	6F	(X)99	4D	A26	4D	1A6	6L	12Z5	7L
27	5A	58	6F	182A	4D	A28	4D	1B4	4K	14Z3	4G
27HM	5A	58A	6F	182B	4D	A30	4D	1B5	6M	25Y5	6E
27S	5A	58AS	6F	183	4D	A32	4D	1C6	6L	25Z3	4G
29	6N	58S	6F	213	4C	A40	4D	2A3	4D	25Z5	6E
30	4D	59	7A	213B	4C	A48	4D	2A3H	4Q	OZ3	5N
31	4D	59B	7M	216	4B	B	4E	2A5	6B	Wunderlich	
32	4K	64	5E	216B	4B	RA	4J	2A6	6G		
33	5K	64A	5E	257	5B	BH	4J	2A6S	6G	A(5)	5H
34	4M	65	5E	264	4D	BR	4H	2A7	7C	A(6)	6N
35	5E	65A	5E	291	5G	BX	4D	247S	7C	Auto	6N
35S	5E	67	5A	293	5G	D-½	4B	2B6	7J	B	6P
36	5E	67A	5A	295	5G	D1	4C	2B7	7D		
36A	5E	68	5E	401	4*	DE1	5A	2B7S	7D		

- 4A Ballast tube. Resistor connected across pins 1 and 4.
- 4N Ballast tube. Resistor connected across pins 2 and 3 with a center tap at pin 1.
- 4\* Special Sparton base, like 4D except filament connection at side of base.
- 5\* Special Majestic ballast tube. Standard 5-prong base, ballast unit connected across filament pins.
- 5† Special Sparton base, see diagram.
- SB Screw base, ballast tubes.

Courtesy "Weston Electrical Instrument Corp."

# TUBE BASE CONNECTIONS

## TOP VIEW OF SOCKET

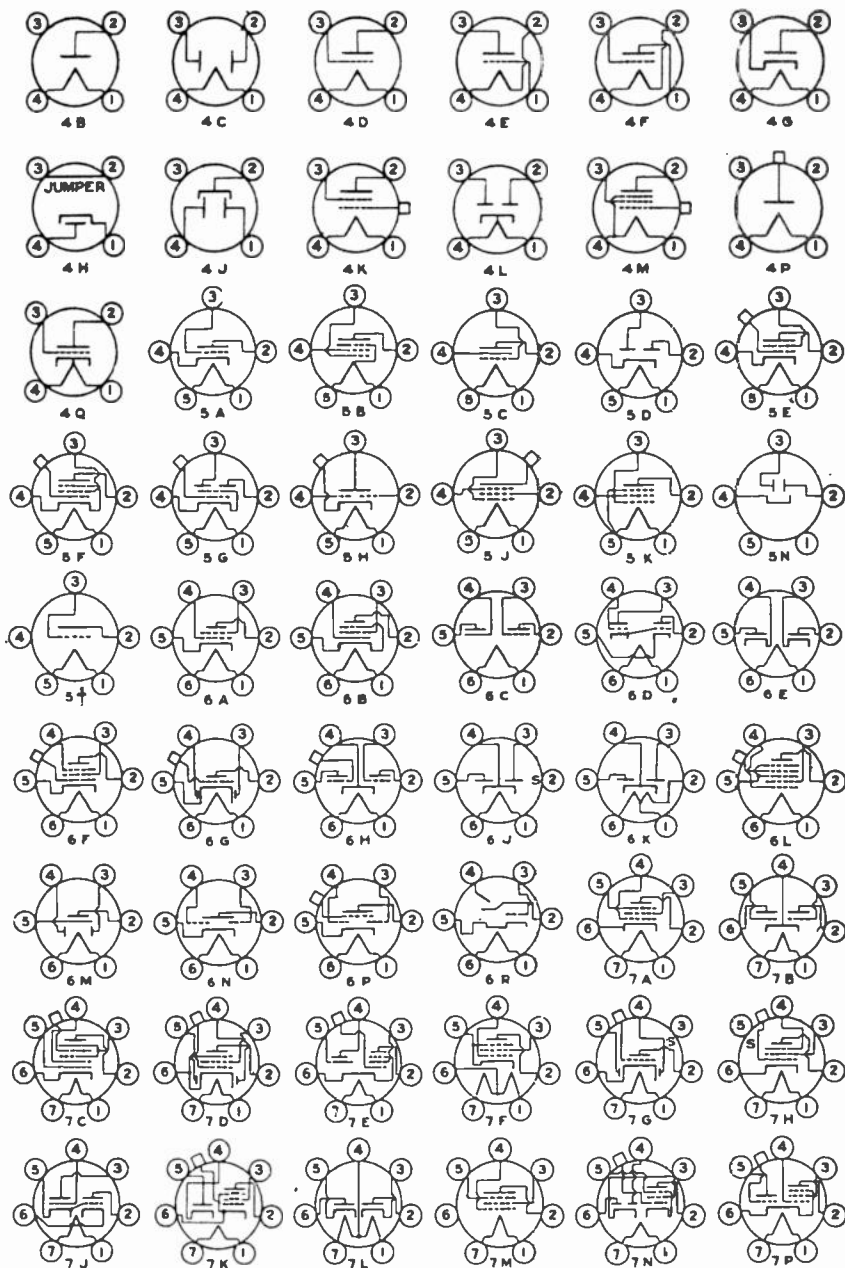

Courtesy "Weston Electrical Instrument Corp."

# Octal Base Tubes

## BOTTOM VIEW OF SOCKET OR BASE OF TUBE

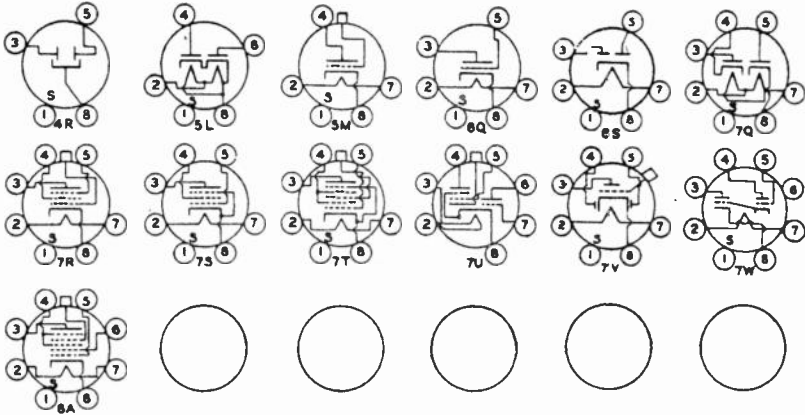

Tube	Base	Tube	Base	Tube	Base	Tube	Base	Tube	Base
0Z4	4R	6C5	6Q	6F6	7S	6K7	7R	6R7	7V
5Y3	5L	6C5G	6Q	6F6G	7S	6K7G	7R	6X5	6S
5Z4	5L	6C5MG	6Q	6F6MG	7S	6K7MG	7R	6X5MG	6S
5Z4G	5L	6D5	6Q	6H6	7Q	6L7	7T	25A6	7S
5Z4MG	5L	6D5G	6Q	6H6G	7Q	6L7G	7T	25Z5MG	7Q
6A8	8A	6D5MG	6Q	6H6MG	7Q	6L7MG	7T	25Z6	7Q
6A8G	8A	6F5	5M	6J7	7R	6N6MG	7T	43MG	7S
6A8MG	8A	6F5G	5M	6J7G	7R	6P7	7U		
6B6	7V	6F5MG	5M	6J7MG	7R	6Q7	7V		

## TOP VIEW OF SOCKET

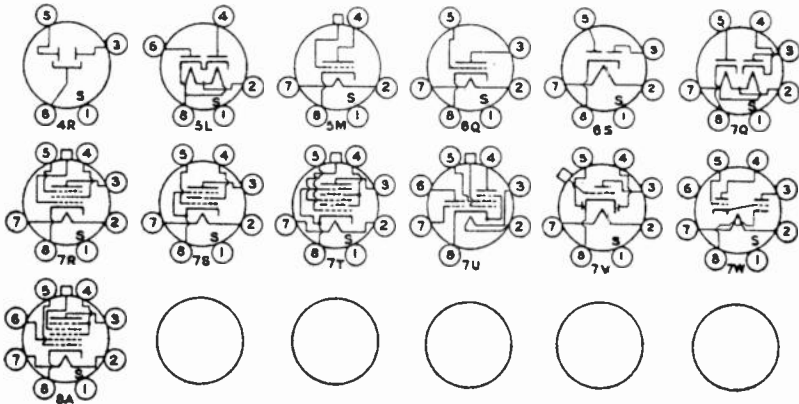

Tubes with the subscript G are glass tubes with no internal connection to pin No. 1.

Arcturus Coronet 24-51 Base 6Q, with pin 5 the screen, and the control grid, the cap.

Arcturus Coronet 27-56 Base 6Q. 2A6-55-75-85 Base 7V.

Arcturus Coronet 57-58-77-78 Base 7R. 80 Base 5L.

Courtesy "Weston Electrical Instrument Corp."

First, let us measure the plate voltage on the type 58 tube, Referring to the tube base chart on page 45, it is seen that a type 58 tube has its elements arranged as shown by socket 6F. For convenience, this socket is illustrated again in Fig. 45. The chart on the right in Fig. 45 illustrates exactly where the voltmeter is to be connected to make the desired measurements. The plate voltage is measured from plate to cathode, which is across pins 5 and 2 of the six-prong tube socket. In other words, the positive lead from a high range voltmeter is inserted in the pin jack marked 2 on the free point tester and the negative lead from the same voltmeter is inserted in the pin jack marked 5. The voltmeter reading then gives the exact plate voltage applied to the type 58 tube.

Tube Base	Voltmeter Connected Between	Voltage Measured	Milliammeter Connected Between	Current Measured
	5 & 2	Plate	2 & 2	Plate
	5 & 3	S. G.	3 & 3	Screen
	5 & 4	Su. G.		
	5 & TC	C. G.		
	1 & 6	Heater		
	1 & 5	Cathode		

Fig. 45 A portion of the chart used with a free-point analyzer.

To measure the screen voltage, the negative lead from the voltmeter remains in jack 5, but the positive lead is changed to pin jack 3. The suppressor grid voltage is also measured with reference to the cathode; hence, the negative lead of the external voltmeter remains in jack 5 and the positive lead is changed to jack 4.

To measure the control grid or bias voltage, the negative lead from the voltmeter is changed from pin jack 5 to the jack labeled "Grid". The positive lead from the voltmeter is then inserted in jack 5. Of course, when making this measurement, the range of the voltmeter should be decreased, because the bias voltage will be much lower than the previous plate and screen voltage measurements. The heater voltage is measured directly across the heater terminals 1 and 6 with a low range AC voltmeter, and a voltage measurement may be made between heater and cathode by inserting one lead of a low range voltmeter in jack 1 and the other in jack 5.

Now, if it is desired to make a plate current measurement on the type 58 tube, insert the leads from the proper range milliammeter in the two jacks that are numbered 2. The positive lead from the milliammeter should be inserted in the jack from the cable and the negative lead inserted in the other jack. The plate current indicated will be that flowing in the plate circuit of the type 58 tube. A screen current measurement can also be made by inserting the positive and negative leads from a proper range

**WIRING DIAGRAM, MODEL 593**

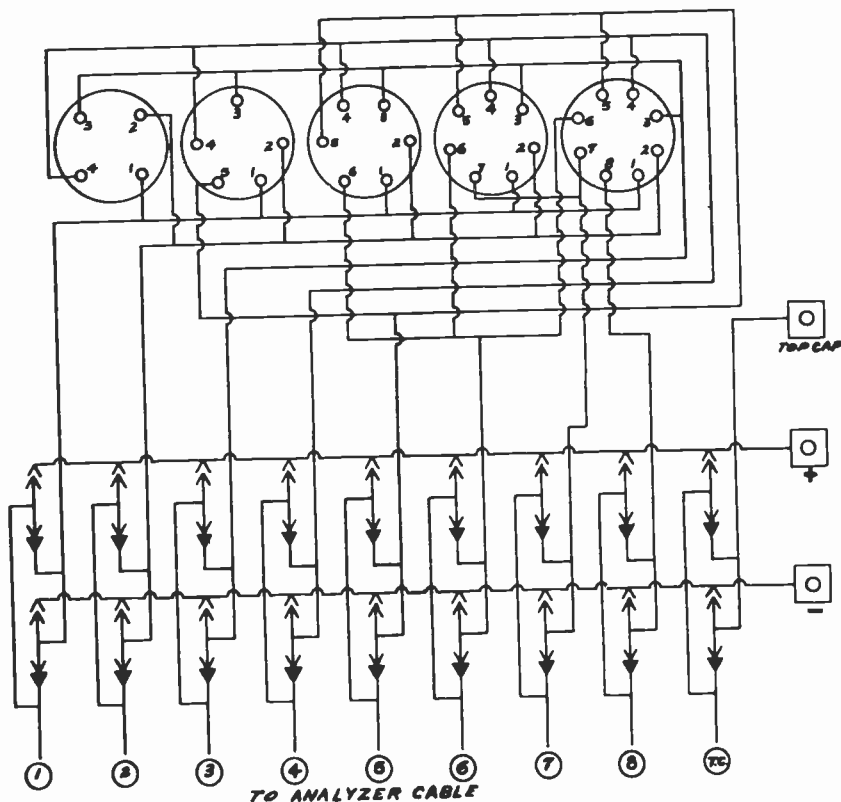

Fig. 46 Another type of free-point analyzer.

milliammeter into the jacks opposite the number 3. The circuit is automatically opened and the milliammeter placed in series. Care should always be taken when measuring voltage or current, to make certain that the proper range meter is selected. For safety purposes, always start with the highest range, then reduce to a lower range if a more accurate reading can be secured.

Fig. 46 shows an adaptation of the analyzer described in the preceding paragraphs. The only difference is in the method of making the metering connections. In place of moving the test probes from jack to jack for the different measurements, they are simply connected to the jacks marked plus and minus. The different measurements are then made by pushing the push buttons specified on the chart provided by the manufacturers of this type of instrument.



One precaution must be observed in the use of the free point analyzer. Before making any measurements, make certain that the meter used is set on the correct range. This precaution will save many burned out meters caused by an attempt to measure high voltages with the measuring instrument set for the measurement of currents.

*In the next lesson, we shall continue to describe the essential test equipment for radio service work. It is important that you learn the design of such instruments before attempting to study actual testing and trouble-shooting procedures.*



The text of this lesson was compiled and edited by the following members of the staff:

G. L. Taylor  
President and Chief Engineer  
Midland Radio & Television Schools, Inc.

C. L. Foster  
Supt. of Instruction  
Midland Radio & Television Schools, Inc.

C. V. Curtis  
Chief Instructor  
Midland Radio & Television Schools, Inc.

R. E. Curtis  
Technical Drafting  
Midland Radio & Television Schools, Inc.

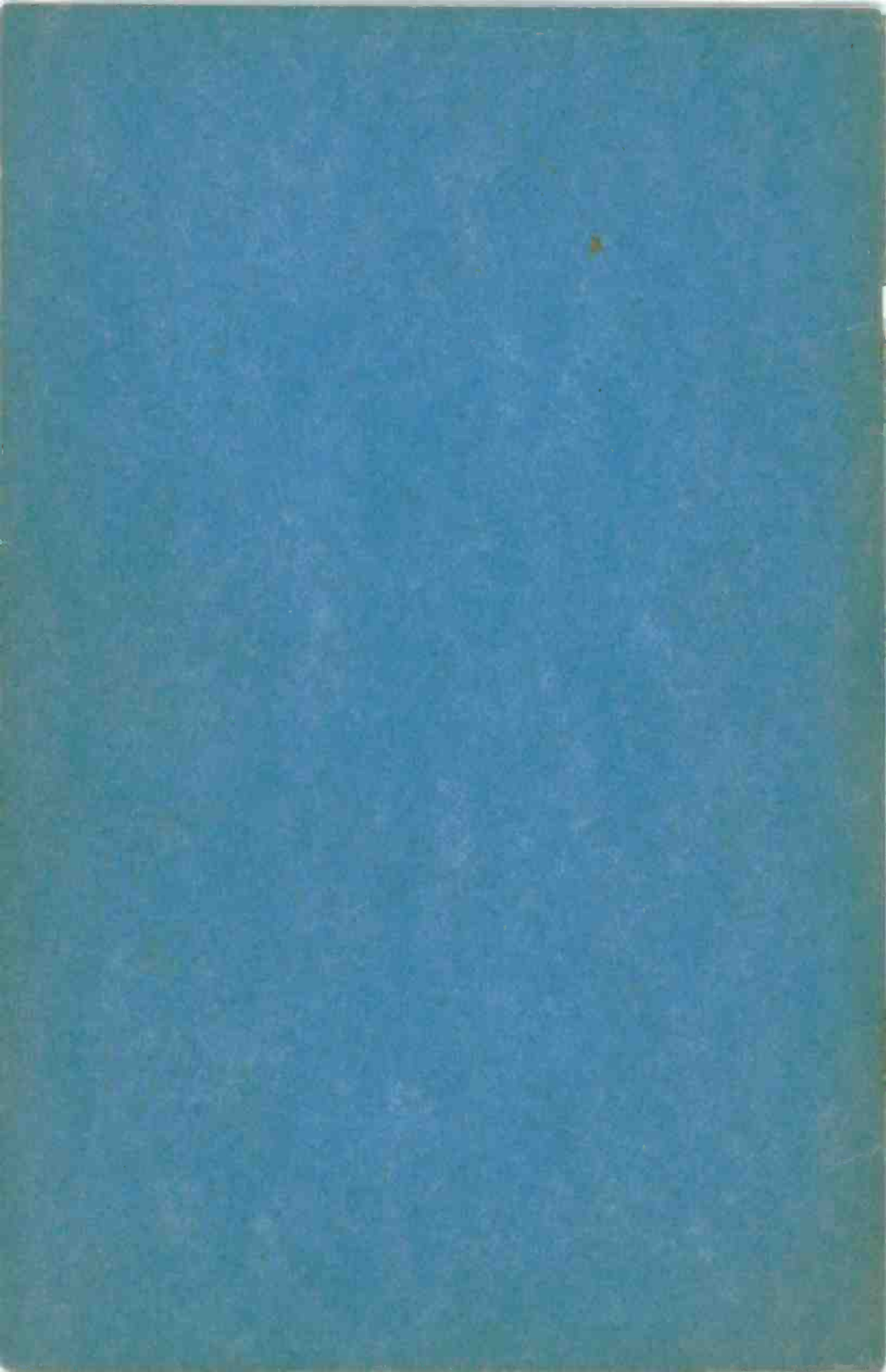



**MIDLAND RADIO  
AND TELEVISION  
SCHOOLS,  
INC.**

**POWER & LIGHT BUILDING, KANSAS CITY, MISSOURI**

**UNIT SIGNAL GENERATORS LESSON  
NO. VACUUM TUBE VOLTMETERS NO.  
2 AND OSCILLOSCOPES 2**

# "IN ONE EAR

.....AND OUT THE OTHER".

You have no doubt heard that expression frequently. Perhaps you were inclined to consider it as rather humorous.

But the expression 'In one ear and out the other' is far from being humorous. It is an expression that has explained the falling of kingdoms. It has lost wars. It has caused human failures.

Information, in itself, is like a liquid. It flows around us all the time, passing from person to person by word-of-mouth, books, the radio, and all other forms of communication.

When information flows around you, you must have the right kind of 'container' in which to capture and hold it. That 'container' is your mind. Some people have 'containers' that are no better than sieves....full of holes and very shallow. The right kind of container (mind) is not shallow, not full of holes, and not rusty. It is, on the contrary, deep, sound, and efficient.

We know that you have the right kind of container. You have proven this by advancing through your training to this point. Your mind has retained all the information which is necessary to progress this far. It has, of course, been a bit difficult at times, we know. But if it wasn't, anyone could be a radio man...no special training would be necessary, and there would be no bright outlook for the trained man, as there is under the present conditions. Any one can be a street-sweeper. But it takes specialized training and a sound mind to be a good radio man.

You have proven that you 'have what it takes'. Congratulations, and keep up the excellent work which you have been doing. You are 'on the way to the TOP'!

Copyright 1941

By

Midland Radio & Television  
Schools, Inc.

PRINTED IN U.S.A.



KANSAS CITY, MO.

# Lesson Two

## SIGNAL GENERATORS, VACUUM TUBE VOLTMETERS, & OSCILLOSCOPES

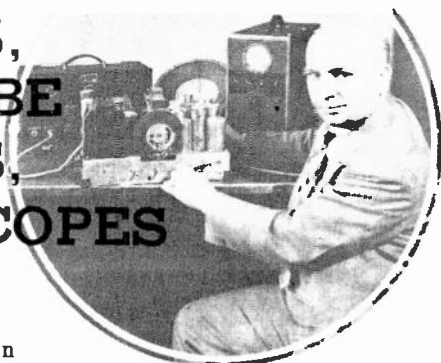

"In Lesson 1 of this unit, you studied the fundamental service instruments. You covered the principle of operation of these instruments and learned exactly how these principles were applied to typical commercial circuits.

"The instruments covered in the first lesson were the continuity meter, ohmmeter, output meters, capacity meters, universal meters, tube testers, and set analyzers. With these instruments, it is possible to set up a successful servicing business. The results obtained will be accurate and dependable. In later lessons in this unit, you will learn how these instruments are actually used in service work, and where each of the instruments can be used to the best advantage.

"In this lesson, we will study the principles of several more advanced instruments. These instruments, the Signal Generator, Vacuum Tube Voltmeter, and the Oscilloscope, are not absolutely necessary to a service engineer. However, their use is so advantageous, most service engineers find they are a "must" for all successful shops. Their use not only gives a more complete picture of the condition of a defective receiver, but also gives that picture more rapidly. The average service engineer will find after completing the studies in Unit 2, that he can select certain fundamental instruments as a foundation for his servicing business. As conditions warrant, he can add further items to his equipment, and thus eventually fully equip his shop.

"As in Lesson 1, we will explain the basic principles of the different instruments, illustrating these principles with typical circuits. It is not our purpose to recommend any one type of equipment. Rather, by explaining the different types and their advantages and disadvantages, it will be possible for the service engineer to select that type of equipment most suited for his needs.

1. SIGNAL GENERATORS. Signal generators, or oscillators as they are also known, have a definite value in radio service work.

It is not only necessary for the successful service engineer to be thoroughly familiar with the circuits of modern radio receivers, but he must be able to make the many tests and adjustments that are necessary. After your studies have been completed, you will know that there are many short-cuts that can be made in the servicing of a radio receiver. However, you will also realize that certain adjustments on a radio receiver must be made with equipment designed for that purpose.

One of the adjustments most frequently made by the service engineer is the alignment of R.F. and I.F. circuits in a receiver. For the best work, a broadcast signal is entirely unsatisfactory. As a rule, the strength of a broadcast signal may vary sufficiently to cause difficulty. The frequency of the broadcast signal is always accurate, but the modulation impressed on the signal corresponds to the voice and music being transmitted; hence it varies in amplitude at irregular intervals.

The signal generator provides the service engineer with a source of radio frequency voltage, modulated at a constant A.F. rate; adjustable to any frequency desired; capable of supplying weak or strong signals; and is available for use at any time desired. By means of a switch on the front panel, the output R.F. and I.F. voltage may be modulated or unmodulated at will. In reality, this piece of equipment is a miniature broadcasting station, wherein complete control is available to the service engineer. By choice, he may adjust to any desired frequency, secure the strength of output voltage desired by manipulating the volume control, and modulate the signal if he sees fit.

As well as providing an accurate means for circuit alignment, the modern signal generator can also be used to:

1. Neutralize Radio Frequency Amplifiers.
2. Determine the gain in voltage secured through a single stage or an entire receiver.
3. Test the performance of tubes under actual operating conditions.
4. Check the efficiency of AVC circuits.
5. Determine the selectivity of an R.F. or I.F. amplifier.
6. Check the performance of AFC (Automatic Frequency Control) circuits.
7. Plot a fidelity curve on the receiver (using external A.F. voltage).
8. Perform miscellaneous jobs, such as measuring capacity, determining the resonant frequency of an R.F. choke, and similar functions.

Some of the above mentioned uses are not possible with all commercial signal generators. Some manufacturers incorporate individual circuits in their design which make certain tests possible that are not available on other equipment.

In the discussion of this instrument, we wish to point out that the names "Signal Generator" and "Test Oscillator" cover the same instrument. Some commercial instruments are known by one name and some by the other.



7

We listed above several uses for the signal generator. Of course, an ideal instrument would be one which would satisfy all these applications, but on the other hand, simplicity of operation and cost must also be considered. Naturally, the most expensive instruments come closest to meeting these requirements, but there are many instruments on the market from low to high prices. The service engineer can make a satisfactory selection only when he is acquainted with the more important requirements necessary for satisfactory service. The following characteristics should be closely studied before deciding on any one type of instrument:

1. *Frequency Range.* The signal generator must cover all frequencies from the lowest I.F. frequency found in superheterodyne receivers to the highest frequency found in present day short wave receivers.
2. *Frequency Stability.* By frequency stability, we mean that when the signal generator is set at any frequency, whether it be I.F. or R.F., it should not drift or vary from its original value, while alignment adjustments are being made.
3. *Voltage Stability.* By voltage stability, we mean that not only should the frequency remain stable, but a good signal generator should have a constant voltage output when the attenuator or volume control is set to a certain value.
4. *Ease of Adjustment.* The adjustment of the frequency by means of the tuning knob and calibrated dial must be easily accomplished. In other words, the mechanical design of the dial and scale must be such that it is easy to set the frequency of the signal generator to any desired value.
5. *Maintenance of Calibration.* When any instrument, whether a signal generator or other type of unit, is purchased, all of the component parts used are new and clean. After being in use for some length of time, it usually accumulates dust and dirt. These factors, together with the normal aging of the parts, cause the calibration of the signal generator to vary from its original value. As this characteristic is perhaps the most important single characteristic of signal generators, all manufacturers have conducted extensive tests on their equipment to determine its performance in this respect. As a consequence, in all modern instruments, those parts affected by dirt and dust are carefully shielded, and those parts liable to change value with age, are of the highest quality to minimize this effect. Tube deterioration is taken care of by flexible circuit design. Since tube characteristics usually change along rather fixed lines, circuits can be so arranged that tube deterioration will not affect the calibration of the signal generator.
6. *Shielding.* Not only should the signal generator as a whole be well shielded to prevent radiation to nearby apparatus, but also individual range circuits should be shielded from each other.
7. *Construction.* Finally, signal generators should be constructed so as to withstand some rough handling without

changing their electrical characteristics. As these units must be carried from place to place, they must also be easily portable.

2. FUNDAMENTAL OSCILLATOR CIRCUITS. In some of the older types of signal generators, the "harmonic principle" was used. In other words, for the higher frequencies, harmonics of the lower frequencies were used rather than fundamental frequencies. This caused quite some difficulty in that if the fundamental frequency was slightly off frequency, the error would be magnified many times in the higher harmonics, resulting in very poor calibration. It can be seen then, that the best design is that in which the operating frequency is on the fundamental at every setting of the dial rather than on some harmonic. More accurate calibration and ease of adjustment to the desired frequency are possible with fundamental frequency oscillators.

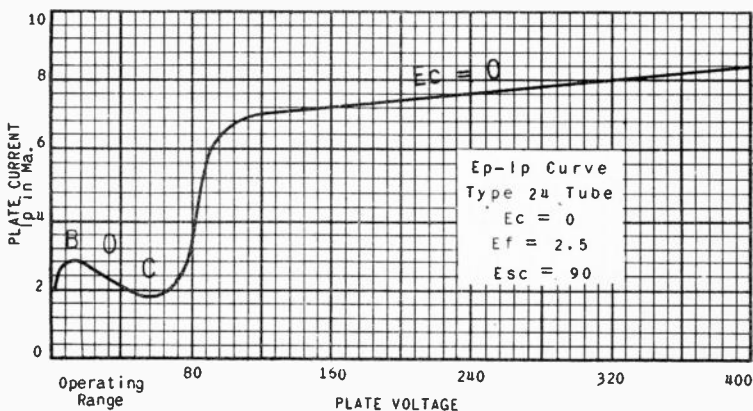

Fig. 1 A dynatron oscillator operates over the Eg-Ip curve from B to C.

There are several oscillator circuits which may be used for signal generators. Among these are:

1. The Hartley Oscillator Circuit.
2. The Regenerative Type of Oscillator Circuit.
3. The Dynatron Oscillation Circuit.

You have previously studied the fundamental Hartley circuit and learned how it generated a high frequency voltage. This circuit is used quite extensively in commercial signal generators, due to its relative simplicity and efficiency. In passing, it may be noted that the method used to obtain grid bias in the Hartley circuit; that is, by means of a grid leak and condenser, is used in all popular self-excited oscillator circuits.

In Unit 1, you also learned about regenerative circuits. In all circuits of this type, it is only necessary to increase the regenerative coupling until continuous oscillations are estab-

lished. This principle of oscillator operation is used quite extensively in commercial signal generators.

The third method of generating a radio frequency signal is known as the Dynatron oscillator. This type of oscillator circuit makes use of the peculiar plate voltage-plate current curve of a screen grid tube. Fig. 1 shows a typical curve of a screen grid tube. You will note that when the plate voltage is less than 90 volts, and remembering that the screen voltage is held at 90 volts, there is a drop in plate current as the plate voltage is increased. The Dynatron oscillator operates over this particular part of the  $E_p$ - $I_p$  curve, (B to C in Fig. 1). The plate voltage for the dynatron oscillator is set at the center of the B-C portion of the curve, and the circuit is connected as is shown in Fig. 2. From this circuit you will notice that the screen voltage is higher than the plate voltage, while the cathode and control grid are tied together.

Fig. 2 A dynatron oscillator.

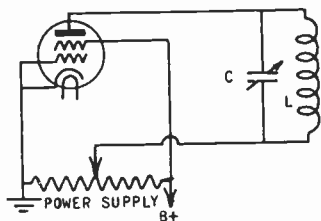

As plate voltage is applied to the Dynatron oscillator circuit shown in Fig. 2, the instantaneous current surge which passes through the oscillating circuit (LC) causes a field to build up around the inductance, and the capacitance (C) to become charged. Assuming that the small voltage generated across the oscillating circuit is in such a direction as to increase the plate voltage, it will be seen from the characteristic curve that the plate current will be decreased. The decrease in plate current through the inductance L will generate a counter voltage across L in the opposite direction. As the counter voltage is created in this direction, the plate voltage will decrease, which causes an increase in plate current. The action repeats and gradually builds up to its maximum. The normal operating plate voltage is at the center of this portion of the characteristic (point O, Fig. 1), and, due to oscillating current changes through the inductance and capacity in the tuned circuit, the plate voltage is changed between points B and C in the alternating fashion.

Quite often, the action of a dynatron oscillator circuit is explained in terms of "negative resistance". Resistance always means a voltage divided by a current. By "positive resistance" is meant that an increase in voltage be accompanied by an increase in current; whereas, the expression "negative resistance" means that an increase in voltage results in a decrease in current. From the characteristic curve of the screen grid tube shown in Fig. 1, it will be noticed that throughout the region from B to C,

a negative resistance characteristic prevails between the plate voltage and plate current; that is, an increase in plate voltage results in a decrease in plate current. This negative resistance of the tube's plate circuit is shunted directly across the oscillating circuit LC. The negative resistance of the tube is in opposition to the positive resistance of the oscillating circuit, and when the negative resistance is equal to the positive resistance, they completely cancel each other, resulting in a net resistance in the oscillating circuit equal to zero.

It has previously been explained that when the net (effective) resistance of an oscillating circuit is zero, the oscillating current does not die out, but remains constant in amplitude. Hence, the oscillating current in the tuned circuit LC will be maintained as long as its resistance is canceled by the tube's opposite resistance.

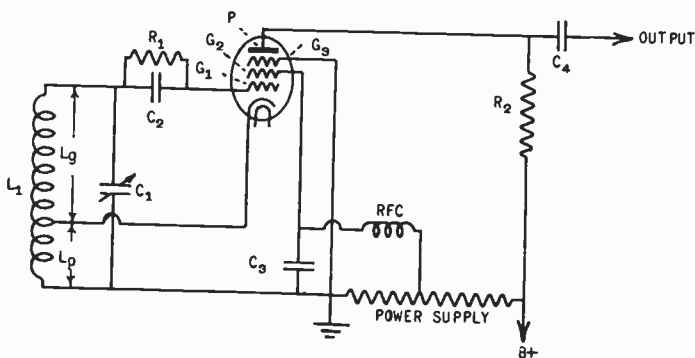

Fig. 3 An electron-coupled oscillator.

A complete treatise on the subject of negative resistance cannot be given because of the higher mathematics involved. Since considerable technical information refers to the action of a dynatron oscillator as a function of its "negative resistance" characteristic, this brief explanation has been included.

The advantage of a dynatron oscillator is its simplicity and the ease with which it can be operated over a wide frequency range. Its frequency stability is also better than the common type of vacuum tube oscillator; that is, its frequency of oscillation varies less with a change in applied plate voltage. Because of its simplicity and stability, it is an ideal oscillator for use with a calibrated wavemeter to make frequency measurements. The outstanding disadvantage which has been responsible for its discontinued use in test oscillator circuits is the weak R.F. voltage that can be secured from it. It will be noticed that the operating voltage over the characteristic curve is limited to a maximum value of around 30 or 40 volts; hence, the radio frequency voltage that can be secured from the oscillating circuit is generally too weak for practical alignment purposes.

In our discussion so far, we have covered only the basic oscillator circuits, with no thought as to output voltage. With the advent of pentodes and multi-element tubes, a new type of circuit was made available which gave a much higher voltage output than the conventional dynatron oscillator. This type of oscillator is known as the electron-coupled oscillator.

The basic circuit for an electron-coupled oscillator is shown in Fig. 3. Examining this, we find a typical Hartley type oscillator circuit. The grid coil and plate coil are actually a single coil with a tap. This inductance ( $L$ ) is tuned by the usual variable capacitor across the total coil. The bias is accomplished by the grid leak and capacitor method. However, one big difference is noted; the anode of the oscillator section is grid No. 2 ( $G_2$ ), and the control grid is  $G$ . Now, examining the circuit, we see that the voltage on the plate of the tube is greater than on the

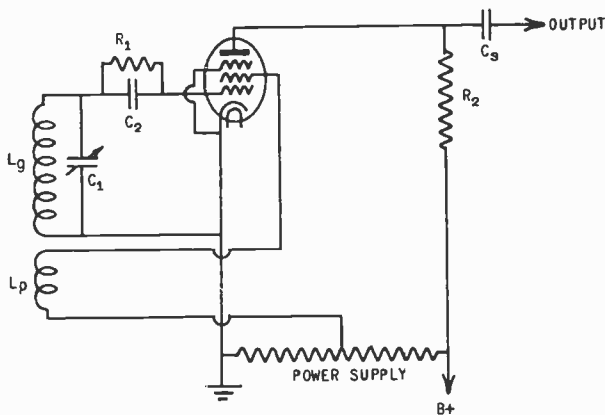

Fig. 4 An improved electron-coupled oscillator.

oscillator anode. Under these conditions, the plate actually attracts those electrons which pass through the open spaces in the control grid and oscillator anode ( $G_2$ ). Now, as these electrons pass through the control grid and oscillator anode, they are affected by the R.F. voltages developed on these elements. The frequency of the R.F. voltages developed between the oscillator anode and the cathode, depends upon the resonant frequency of the LC oscillator circuit. The oscillating currents in LC cause R.F. voltage variations on  $G_1$ , and those electrons passing through the control grid  $G_1$ , to the oscillator anode  $G_2$ , are varied at a corresponding frequency. With a higher voltage on the plate of the tube than on the oscillator anode  $G_2$ , those electrons passing through  $G_2$  are attracted to the plate and cause a variation in the plate current at the same R.F. frequency. The resistor  $R_2$  in the plate circuit provides an impedance across which the R.F. voltage

is developed. The condenser  $C_4$  acts as coupler to the external circuit.

In this circuit, the oscillating portion of the circuit is actually coupled to the output circuit by the electron stream between the cathode and plate of the tube. The plate of the tube is not part of the oscillating circuit, but acts purely as a coupling device.

Not only is the R.F. output voltage higher in the electron-coupled oscillator, but the frequency stability is somewhat better than the dynatron circuit and the other fundamental circuits. Also, variations in the plate supply voltage have practically no effect on the frequency of the generated oscillations, as the plate is shielded from the oscillator section by the suppressor grid. However, you will note that the current in the plate circuit of the tube also passes through the plate inductance  $L_p$ , which is, of course, part of the oscillating circuit. Under these conditions, the load connected to the output will affect the generated frequency to some extent.

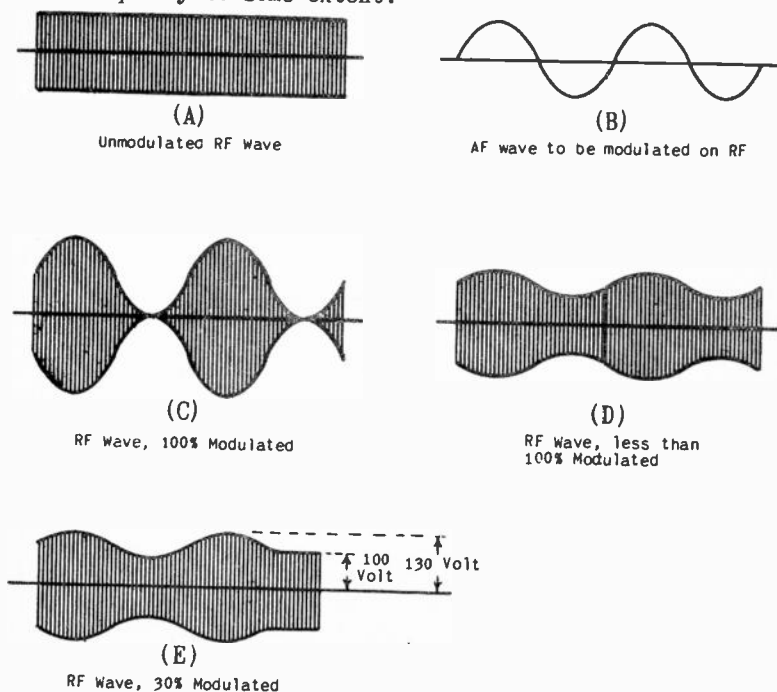

Fig. 5 Drawings to illustrate the percentage of modulation.

This rather objectionable feature can be remedied by the circuit shown in Fig. 4. Here, we have the grid and plate inductances separated, and the circuit now resembles the conventional regenerative or inductive feedback circuit. Another advantage of this circuit is that the cathode can be connected directly to

ground. This reduces the effect of external capacities upon the generated R.F. signal.

When using a signal generator in service work, we generally use some type of indicating instrument at the output of the receiver. It may be located across the output tube's plate circuit or across the voice coil of the speaker. In either case, to obtain a reading on the indicating meter, a modulated signal must be delivered by the signal generator. If an unmodulated signal is used, there will be no indication after the second detector stage. Also, if the modulation is not steady, it will be impossible to make satisfactory adjustments on the receiver under test. A broadcast signal is unsatisfactory in this respect, as it is continually varying in amplitude and may not be the desired frequency. For these reasons, A.F. modulation of constant frequency and amplitude is provided in all signal generators.

Fig. 6 A grid modulated oscillator.

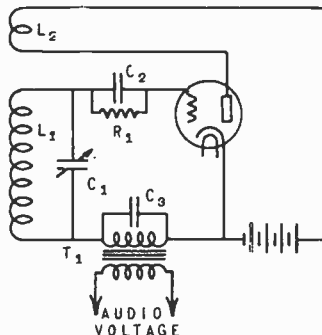

In the alignment of receivers, it has been found that a modulation of 30% gives the best results. Percentage of modulation may be defined as the ratio between the increase or decrease of a signal, due to the modulation, to the amplitude of the unmodulated R.F. signal. To further define this term "percentage of modulation", let us examine Fig. 5.

Fig. 5A represents an unmodulated R.F. signal as generated in a signal generator. Fig. 5B represents the A.F. signal which we wish to impress upon the R.F. signal. This A.F. signal may be generated either within the signal generator, or externally, as the occasion requires. Fig. 5C shows an R.F. signal modulated 100% by the A.F. signal impressed upon it. In other words, the amplitude of the audio signal is sufficient to cause the R.F. signal to vary from its normal value, to twice its normal value, back to zero, and then back to its normal value again. If the amplitude of the A.F. signal is of a lesser value and does not produce as big a variation in the R.F. voltage amplitude, the percentage of modulation is less than 100%, as shown in Fig. 5D. In Fig. 5E, we have an R.F. signal of 100 volts being modulated by an A.F. voltage which provides a peak R.F. voltage of 130 volts. The ratio of the increase in voltage to the unmodulated R.F. signal is 30 to 100, or 30%.

Two of the methods of modulating an R.F. signal with an A.F. signal are known as grid modulation and plate modulation. As their names imply, when the A.F. signal voltage is introduced in the grid circuit, it is known as grid modulation, and when the A.F. signal is introduced in the plate circuit, it is known as plate modulation.

Fig. 6 shows a typical regenerative oscillator that is being modulated by the grid modulation method. Oscillations are generated in this circuit through the mutual inductance coupling between the grid and plate coils  $L_1$  and  $L_2$ . The audio frequency is introduced into the grid circuit through the audio frequency transformer  $T_1$ . Condenser  $C_3$  is of such a value that it offers a high impedance to the A.F. frequencies, but a low impedance to R.F. frequencies. When no audio voltage is being applied through the transformer, the R.F. output will be constant in amplitude or unmodulated. When an audio frequency voltage is applied to the primary of the audio transformer, a corresponding voltage is developed across the secondary. The A.F. voltage has an effect on the grid excitation the same as the R.F. voltage generated in  $L_1C_1$ ; or, in effect, the A.F. and R.F. voltages are in series. As a result, the plate current, feedback, and oscillations in  $L_1C_1$  will be varied in accordance with both signals. The percentage of modulation is controlled by controlling the amplitude of the A.F. voltage applied through the audio transformer.

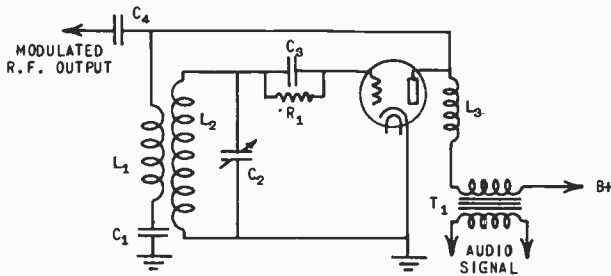

Fig.7 A plate modulated oscillator.

Plate modulation is shown in a fundamental oscillator circuit in Fig. 7. This is a conventional feedback circuit, in which regeneration is obtained through the mutual inductance between the grid and plate coils. The B supply is fed through the secondary of the audio transformer and the plate coil  $L_1$  is connected in series with a blocking condenser  $C_1$  to ground. The condenser keeps the B supply from being shorted. The R.F. choke  $L_2$  is inserted in the plate lead to prevent the R.F. oscillations from feeding back into the A.F. transformer and power supply. If no A.F. voltage is applied to the primary of the audio transformer, the plate voltage will remain constant and the output from the oscillator will be an unmodulated R.F. signal; that is, the amplitude of the R.F. oscillations will be constant. Now, if we



place an A.F. voltage across the primary of the audio transformer, the plate voltage will be varied at the same audio frequency by the voltage induced in the secondary of the A.F. transformer, and, in turn, the amplitude of the R.F. signal will be varied accordingly. The percentage of modulation is controlled by the amplitude of the A.F. voltage impressed on the primary of the transformer.

Another type of modulation has recently been introduced; but as yet, has not become popular. It is known as cathode modulation. In this method, the secondary of the modulation transformer is placed in the cathode circuit. Such a circuit is shown in Fig. 8.

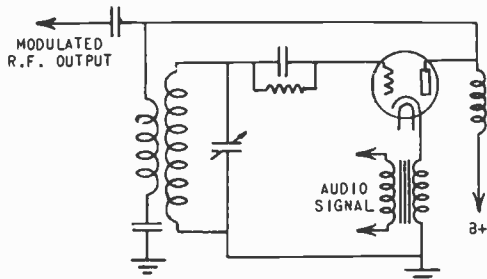

Fig. 8 A cathode modulated oscillator.

As the A.F. voltage is applied through the transformer, the plate current is affected directly by that voltage, since the effective voltage between cathode and plate is increased and decreased at the A.F. frequency. Also, the effective bias on the grid is indirectly affected due to the voltage drop across the DC resistance of the transformer secondary. Thus, we find that "cathode modulation" is, in effect, a combination of plate modulation and grid modulation.

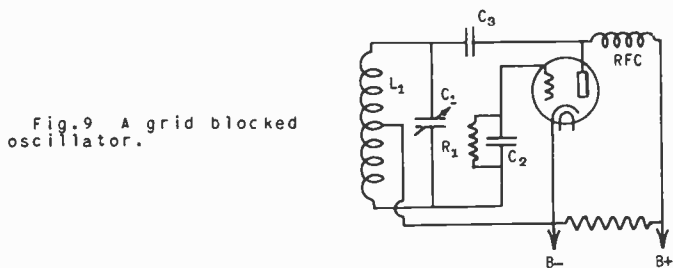

Fig. 9 A grid blocked oscillator.

Of the three types of modulation, plate modulation is the most efficient. In actual practice, it may be from 75% to 80% efficient. For this reason, it is the one most generally used in signal generators. Cathode modulation is from 50% to 60% efficient, and grid modulation is from 35% to 40% efficient.

In Unit 1, another method of modulating an oscillator was discussed; namely, the grid blocking method in the Hartley circuit. For convenience, the circuit is shown again in Fig. 9. As explained before, when the grid leak resistance  $R_1$  is less than 50,000 ohms, the amplitude of the R.F. oscillations remains constant. However, as the value of this resistor is increased, a blocking action takes place at a regular frequency. The higher the value of the grid leak resistance, the lower the A.F. frequency. This system is rarely used except in very cheap oscillators, in which no control of the percentage of modulation or the frequency of modulation is required.

It was previously mentioned that electron-coupled oscillators are used quite frequently in modern commercial signal generators. This type oscillator can easily be modulated by the introduction of an audio frequency voltage in the anode circuit of the oscillator section, which is grid  $G_2$  in Fig. 3. Referring to Fig. 10, when an audio frequency voltage is applied to the primary of  $T_1$ , the secondary voltage is in series between the oscillating circuit and the anode of the oscillator, thus causing the amplitude of the oscillating current in  $L_1C_1$  to be varied at an audio frequency rate.

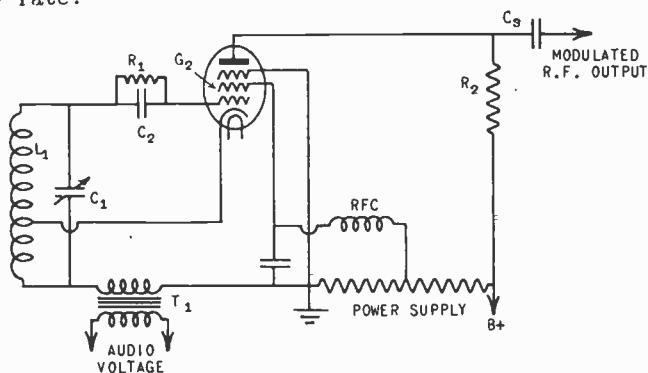

Fig.10 A modulated electron-coupled oscillator.

The modulated electron-coupled oscillator shown in Fig. 9 employs a pentode tube. Several commercial generators use a seven-element tube, such as the 2A7, for this purpose. In circuits of this kind, the modulating signal is generally applied to the second grid; the first grid is the control grid for the oscillator, and the third and fifth grids are tied together for the oscillator anode.

The audio frequency signal may be obtained in several ways. The usual practice is to use a separate tube for that purpose. Fig. 11 shows a basic A.F. oscillator circuit in which the plate coil  $L_1$  is tuned by  $C_1$ .  $C_2$  has a negligible effect on the frequency, due to its very high capacity. In this circuit, the plate coil is the primary of an A.F. transformer having a high

inductance. The tuning capacitor  $C_1$  is also a rather high capacity. From our previous studies, we can understand that in tuned circuits, high values of  $L$  and  $C$  give low values of frequency. The usual audio frequency in commercial signal generators is 400 cycles.

The audio oscillator may also be a triode section in a dual purpose tube. This method is seldom used, however, due to the circuit complications involved.

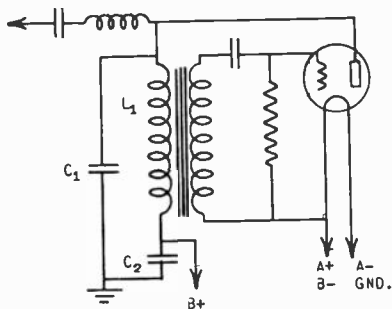

Fig. 11 An A.F. oscillator circuit.

Before studying the circuits of a typical signal generator, let us study some of the methods of attenuation used in signal generators. Actually, an attenuator operates the same as the volume control on a radio receiver. It controls the amplitude of the R.F. signal delivered by the signal generator to the receiver under test.

There are two definite requirements of an attenuator in a signal generator. First, it must be capable of giving accurate control of the signal from an extremely low value to full output. In those receivers employing AVC, it is necessary to keep the input signal at a low value so that the AVC action will not affect the adjustments made during the alignment of the receiver. Also, in some tests, it is necessary that the exact signal voltage being applied to the receiver be known. In the second place, it is necessary that, regardless of the output voltage from the attenuator, the load on the oscillator circuit must remain constant. This is necessary, due to the fact that practically all oscillator circuits will change frequency to some extent when the load on the output is changed. To overcome this condition, most manufacturers use a "pad" control.

In Fig. 12 we have illustrated several pad circuits typical of those used in commercial signal generators. Fig. 12A shows the simplest pad circuit. It is, in effect, a potentiometer across the output of an oscillator transformer. The voltage is adjusted across this potentiometer. This unit has the disadvantage that close calibration cannot be made at the lower output voltages.

Fig. 12B illustrates a type of attenuator in which two controls are used. A High-Low switch and a potentiometer are used for these two controls. With the switch in the "High" position,

the potentiometer is placed across the total output of the oscillator. When the switch is in the low position, resistor  $R_1$  and the potentiometer are in series across the output of the oscillator. As a result, the R.F. voltage at the output terminals is only a percentage of the total oscillator output. If  $R_1$  and the potentiometer have the same resistance value, the R.F. voltage will only have a voltage equal to 50% of the full oscillator output, when the potentiometer is in the maximum position.

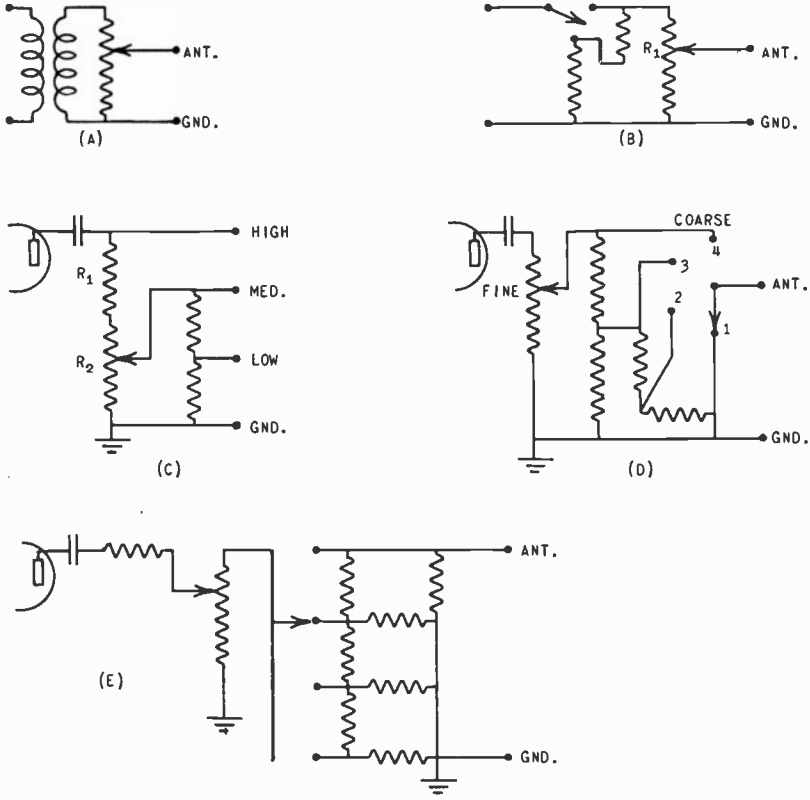

Fig.12 Various attenuators for oscillators.

Fig. 12C illustrates a slightly different method of obtaining various output voltages. In this case, the voltage between the High tap and ground is not variable. It is used where circuits are so far out of alignment that an extremely strong signal is required. However, when a lower voltage is required, the "Med." or "Low" taps are used. In the case of the "Med." tap, only a part of the maximum output of the oscillator is used. The voltage available depends upon the value of the series resistor and the potentiometer. Again, the "Low" tap provides for the use of only a small portion of the total voltage available at the medium tap.

A further development of this type of network is shown in Fig. 12D. Here, in place of using several binding posts on the instruments, a tapped switch is used to connect the various points in the network to the output posts. Both Figs. 12C and 12D illustrate a feature which is very advantageous. In both cases, we find that the adjustable control or potentiometer is placed in the high voltage circuits, while the voltage dividing circuits are placed after the potentiometer. This makes it possible to obtain very close adjustment of the voltage, especially in the lower voltage range. To further explain this, let us examine Fig. 12C. If the voltage between the "High" and "Gnd" terminals is one volt, it would be practical to make the voltage between the "Med." and "Gnd" terminals a value of .2 volt, this would mean that  $R_1$  has 4 times the resistance value of the potentiometer. Again, the voltage between the "Low" and "Gnd." terminals would be set at a value of .02 volt. Now for the sake of simplicity, let us assume that the potentiometer has an active range of 200 degrees. If this is the case, then for each degree of rotation, the output at the "Med." terminal varies .001 volt, or 1 millivolt, and the voltage at the "Low" terminal varies .00001 volt, or 10 microvolts for each degree of rotation of the attenuator control. Now, if the output circuit were arranged as shown in Fig. 12B, the best control would be only 1 millivolt per degree of rotation. In most cases, this large degree of variation is too great for close work.

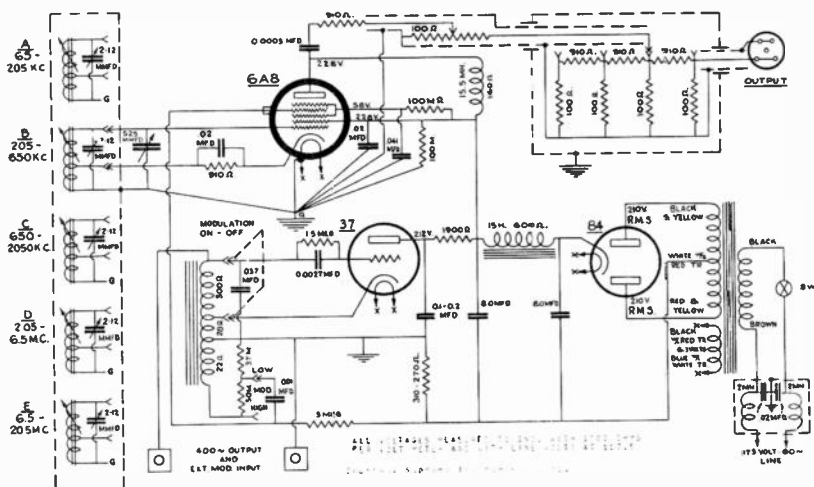

Fig. 13 Schematic of a commercial signal generator.

Fig. 12E shows one of the more complicated networks. As the coarse control is adjusted from the high to the low taps, less resistance is placed across the potentiometer, and more resistance is placed in series with the load across the output terminals. This acts exactly as any voltage divider, in cutting the voltage across the output terminals.

Most signal generators are constructed along the same lines; that is, they all have much the same mechanical characteristics, differing mainly in the number of bands used to cover the frequency range, the method of changing bands, and the method of controlling the output. The controls usually consist of a main tuning dial, a range switch, one or two attenuators or volume controls, and a modulation control. Some signal generators are entirely self-contained, using batteries as a source of power, while others are designed to operate from a standard power line.

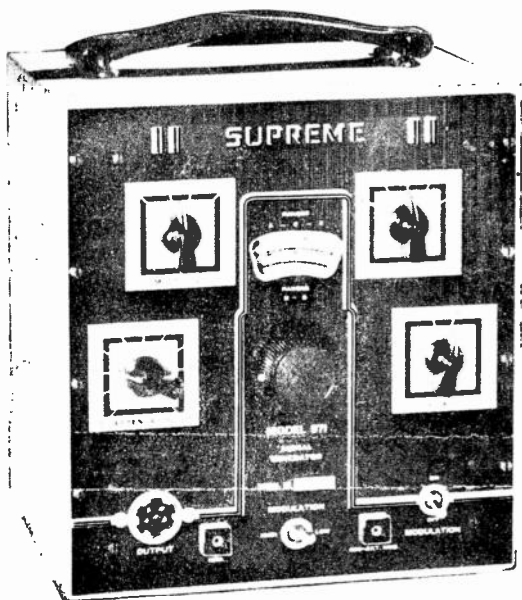

Fig. 14 Photograph of the signal generator whose diagram is given in Fig. 13. (Photo, Courtesy Supreme Inst. Corp).

Fig. 13 shows the schematic diagram of a typical commercial signal generator. A photograph of this instrument is shown in Fig. 14. This unit is designed to cover a frequency band from 65 kc. to 20.5 mc. This is accomplished through the use of 5 different coil and trimmer combinations, using a single common tuning capacitor. The oscillator circuit is an electron-coupled circuit and uses the multi-element type 6A8 tube. In this case, grid #1 is the control grid of the oscillator and grid #2 is the anode of the oscillator circuit. Grids #3 and #5 are tied together internally and act as a screen or suppressor grid. The modulation signal is obtained from a 37 tube connected in a feedback circuit. The voltage is fed from an auto-transformer, which is part of the oscillating circuit, to grid #4 of the 6A8. The A.F. signal applied to this grid controls the electron flow to the plate of the 6A8, and, in this way, modulates it at the audio frequency desired. By means of a voltage divider across the secondary of the modulating auto-transformer, control of the percentage of

modulation is obtained. The low tap gives 30% modulation and the high tap gives 75% modulation. Two binding posts are connected to the primary of the modulating transformer, which may also be considered as the tuning coil of the audio oscillator. These connections serve a double purpose. They supply a 400 cycle audio signal for the testing of audio frequency amplifiers, such as public address equipment, inter-office communication systems, etc. If the switch connecting the 37 oscillator to the tuning inductance is opened, an external source of audio frequency signals can be connected to the binding posts. In this case, the external audio frequency signal will be the modulating frequency. This connection is used when it is desired to measure the overall fidelity of a radio receiver, in which case the external source of audio frequency will be a variable audio frequency generator.

Power for both the radio frequency and the audio frequency oscillators is obtained from a type 84 tube connected in a conventional full-wave circuit. As the DC power is supplied to both the audio frequency and radio frequency circuits must be as free from ripple as possible, a two-stage filter circuit is used in the output circuit of the rectifier.

The attenuator circuit in the output of the R.F. oscillator is of the voltage divider type. Accurate control is provided by a switch and a potentiometer in the voltage divider circuit. As explained previously in this lesson, this system gives accurate control of extremely low voltages in the output of the signal generator.

Inasmuch as we are concerned with oscillators in general at this point, let us also study some of the other oscillators or signal generators used in the servicing of radio receivers. There are two other types of oscillators with which we should be familiar. One, the audio frequency or beat frequency oscillator, we shall consider next. The other, known as the sweep frequency oscillator, will be discussed later in this lesson under that section devoted to the study of oscilloscopes. The reason for postponing the study of this particular unit will be made clear at that time.

3. AUDIO FREQUENCY OSCILLATORS. There are many uses for audio frequency oscillators in radio service work, a few of which we are listing below. Among other services, this instrument can be used to:

1. Measure the overall fidelity of a radio receiver.
2. Measure the frequency response of an audio amplifier.
3. Determine the characteristics of audio filters.
4. Measure unknown frequencies by comparison.
5. Determine the modulation characteristics of Amateur Phone Transmitters.

Although we will not explain at this point how all these measurements are made, we do want to impress upon you the variety of uses to which this instrument is adaptable. Throughout the remaining lessons in this unit you will find further explanations concerning the use of audio frequency oscillators.

There are two types of audio frequency signal generators available. One, known as the audio frequency oscillator consists of either one or two tubes. One is used as a straight audio oscillator, and, if the strength of the signal is not sufficient, an amplifier tube is provided. A discussion of this type of circuit has been given in the study of the signal generator, where it was used as a source of the modulating signal. This type of audio frequency oscillator is seldom used in commercial instruments due to its many disadvantages. In the first place, it is quite expensive. Due to the low frequency, high values of inductance and capacity must be used. These units must be constructed carefully so that external influences will not change their characteristics. Such construction makes the cost of the complete unit almost prohibitive. The big objection, however, is that the stability of this type of oscillator is very poor. Obviously, the setting of the oscillator must remain fairly close or erroneous results will be obtained when taking measurements. Due to the high values of inductance and capacity, any slight change in either will result in a large change in frequency. This type of oscillator is also likely to drift while in use, due again to the effects of heat and atmospheric moisture on the inductance and capacitance circuits.

The other type of audio frequency generator, and the one most commonly used in commercial instruments today, is known as the beat frequency oscillator. In a previous lesson, you have studied the principle of superheterodyne receivers. In that lesson, it was found that if two signals of different frequencies are fed into a non-linear detector, the resultant signal in the plate circuit (the beat frequency) will be equal to the difference between the two signals. If one oscillator is fixed in frequency; then by combining it with a signal of a slightly lower frequency, the resulting signal will be a sine wave of a frequency equal to the difference between the fixed frequency and the variable frequency. In superheterodynes, the resultant frequency is the I.F. frequency, and is usually from 150 kc. to 450 kc. Now, if in place of the incoming signal in a superheterodyne, we use a second oscillator, and combine the two signals in a non-linear detector, the resulting signal will be at the beat frequency. Then, it is only necessary to have the difference between the fixed frequency and the variable frequency fall in the audio range, and we have an audio frequency signal generator.

Fig.15 shows the schematic diagram of a typical beat frequency oscillator. In order to better understand the principle of operation of this unit, we will examine each part of the circuit and determine what function it performs in the circuit as a whole.

The first tube, a 6J7, is operated as a fixed oscillator. Upon examining this circuit, we find that it is a typical electron-coupled oscillator. Grid #1 is the oscillator control grid, while grids #2 and #3 are connected together and act as the oscillator plate. The plate of the 6J7, or "working plate" as it is better known, is electron-coupled to the oscillation section of the tube, and feeds into the primary of a transformer. The second-



dary of this transformer is connected in series with the cathode of a self-biased 6C5 detector tube. This provides for detector-cathode modulation at the frequency of the fixed oscillator. The frequency of the fixed oscillator is usually 950 kc.

The variable R.F. oscillator stage utilizes a circuit similar to that of the fixed oscillator, except that the main tuning control (C12) is connected across coil L6, and provides the required variation of capacitance to change the frequency from 30 to 15,000 cycles below that of the fixed oscillator. The electron-coupled "work plate" is resistance-capacitance coupled to the grid of the 6C5 detector tube. This provides detector-grid modulation at the frequency of the variable oscillator.

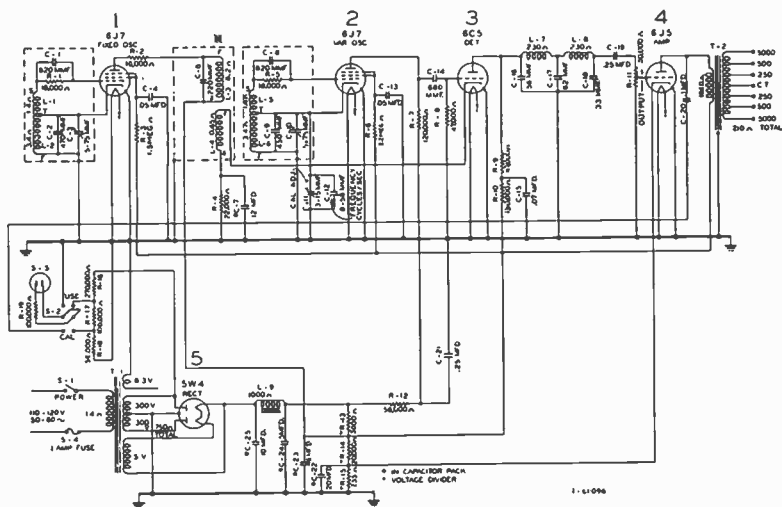

Fig.15 A typical beat frequency audio oscillator.

Use of electron-coupling in each oscillator circuit provides good stability and prevents external circuit effects from reflecting to the oscillator circuits, which would otherwise have a tendency to cause frequency drift, instability, and non-uniform output.

The two R.F. oscillator signals entering the detector; one at the cathode circuit, and the other in the grid circuit; are combined to produce the desired audible (beat) frequency. The detector output is fed to the control grid of the 6J5 fixed-bias amplifier, through a two-stage R.F. filter. This filter allows only the detected audio voltage to be applied to the amplifier grid. The output control (R<sub>11</sub>) is connected in the grid circuit of the amplifier stage, and allows continuous control of the output voltage. The output of the amplifier stage is then fed into an output transformer.

The power supply consists of a 5W4 full-wave rectifier working into a capacitor-input filter circuit. The output of this filter circuit supplies the DC voltages required for the various circuits of the apparatus.

A neon lamp is incorporated for use either as a pilot lamp or as a calibration indicator, depending upon the position of the switch. In the "CAL." position, a portion of the AC voltage from the high voltage winding of the power transformer is impressed on one plate of the neon lamp, from the junction of resistors  $R_1$ , and  $R_{10}$ , through a 100,000-ohm resistor ( $R_{10}$ ). The other plate of the neon lamp is connected through capacitor  $C_{20}$  to the output of the 6J5 amplifier. Proper calibration is indicated when the two frequencies to the neon lamp are the same. The lamp will then remain lighted continuously or remain out continuously, depending upon the phase relation of the applied voltages. When the frequencies are nearly the same, both plates of the lamp will flash together at the difference frequency. In the "USE" position, the neon lamp is connected from the junction of resistors  $R_{10}$  and  $R_1$ , to ground, and acts as a pilot lamp. A small condenser ( $C_{11}$ ) is connected in parallel with the main tuning control to change the frequency of the variable oscillator for setting the calibration point.

4. VACUUM TUBE VOLTMETERS. In previous lessons, both in Unit 1, and in the first lesson of Unit 2, quite some time has been spent in the study of voltage measuring devices. These studies have covered both AC and DC instruments designed for a particular application. These instruments, however, have certain characteristics which make them unsuitable for use in some instances in radio service work. In the first place, any moving coil, or similar meter, does not respond the same to all frequencies, particularly the R.F. and I.F. bands. For that reason, any calibration of these meters must be made at the frequency at which it is to be used. Such a calibration is usually impossible for the average service engineer, due to the lack of sufficient equipment. In the second place, these meters have a definite impedance, usually quite low, which causes unstable operation of a radio receiver when placed in the circuit. In most cases, placing a standard voltmeter in the grid or plate circuit of an R.F. or I.F. amplifier tube causes the tube to oscillate. This, of course, makes no difference insofar as the measurements of DC voltages are concerned. However, if we are attempting to measure the gain in a vacuum tube circuit, the oscillating condition would make our measurements of no value.

A vacuum tube voltmeter makes use of the characteristics of some vacuum tubes for measuring voltages. It has the distinct advantage of having a constant calibration curve regardless of the frequency at which it is used. That is, it can be calibrated at 60 cycles, and the same calibration may be used at 20 megacycles. In addition, the input impedance of a vacuum tube voltmeter is extremely high, and, as a result, may be used without upsetting the normally stable conditions in a radio receiver.

When studying the action of a triode as a biased detector, we found that the average plate current increase depends upon the amplitude of the grid-exciting voltage. This is due to the curvature of the Eg- $I_p$  characteristic on the lower end of its curve. Now, if we place a milliammeter in the plate circuit of this tube, it will read the average plate current, and is, in itself, an indication of the amplitude of grid-exciting voltage. It is, therefore, easy to either calibrate the milliammeter against the grid-exciting voltage, or to actually substitute the scales in the meter to read the grid-exciting voltage directly. This, then, is the fundamental principle of all vacuum tube voltmeters. This principle of operation is often referred to as the square law operation of vacuum tubes. That is, the plate current changes in proportion to the square of the applied grid voltage.

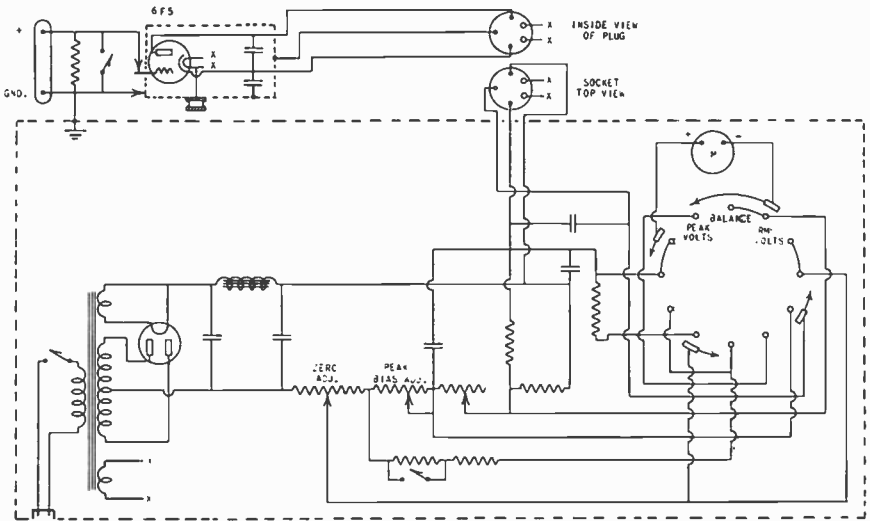

Fig. 16 A typical vacuum tube voltmeter.

Fig. 16 is a schematic diagram of a typical vacuum tube voltmeter. Figs. 17 and 18 show photographs of two representative types of these instruments. The circuit in Fig. 16 has one decided advantage in that the grid of the vacuum tube is used as a contact probe. Examining the circuit, we find that a 6F5 tube is used. The control grid on this tube is brought out through a cap in the top of the tube. By placing this tube and its socket at the end of the connecting cable, the grid connection on the top of the tube can be used to contact the point in the circuit where the voltage is to be measured. This feature has certain decided advantages. First, if long unshielded leads are used between the instrument and the circuit being measured, the capacity between the leads is likely to cause losses, giving erroneous readings. This is particularly true in R.F. circuits. Second, these long unshielded leads often pick up stray induced voltages which may

come from the power transformer, the set oscillator, or some similar source. Again, erroneous results are obtained, and often false deductions are made as to a radio receiver's condition. By placing the grid of the tube on one side of the circuit to be measured, all doubt as to the presence of capacity or induced voltages is removed. When measuring DC or low frequency circuits, two binding posts are provided for connecting regular test leads. A three-position switch is provided for the measurement of either RMS or peak values of voltage.

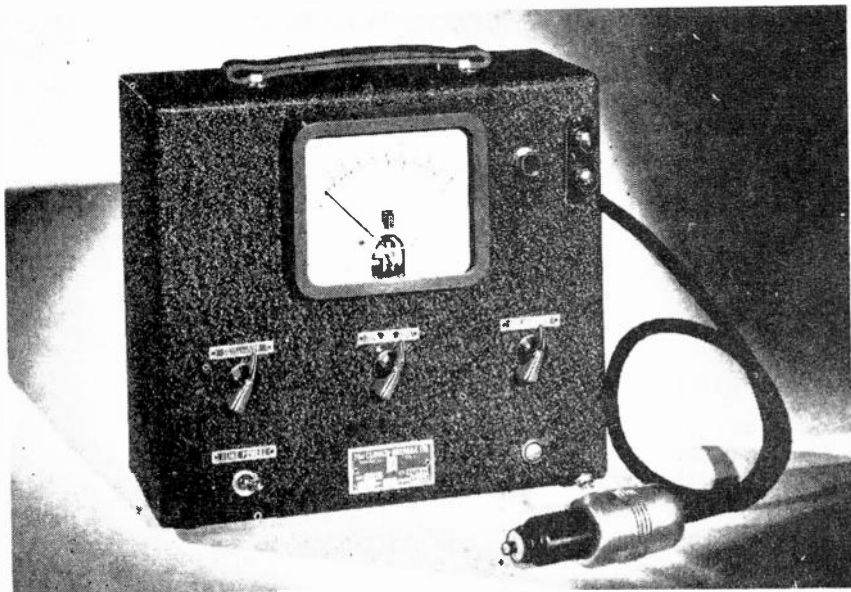

Fig.17 A representative vacuum tube voltmeter.

Peak values of voltage are measured by the "Slide Back" or "Voltage Differential" method. This is done by adjusting the bias voltage for 0 plate current, or plate current cutoff. The voltage to be measured is then applied to the instrument through the grid of the 6F5. The bias voltage is again adjusted for plate current cutoff. By turning the switch to the peak voltage point, the difference in bias voltage is read on the scale of the meter, which gives a direct reading of the peak voltage being measured.

As well as being useful as an accurate output indicating device when aligning radio receivers, a satisfactory vacuum tube voltmeter can also be used for:

1. Measurement of signal voltages in the various stages of the I.F. amplifier.
2. Measurement of filter ripple.
3. Measurement of signal gain per stage in the A.F., R.F., or I.F. amplifiers.

4. Measurement of the signal voltage across resistors, coils, etc.
5. Measurement of DC automatic volume control voltage across the diode and automatic volume control resistors.
6. Measurement of grid bias as supplied by AVC systems.

The various methods employed to make these measurements will be discussed in later lessons of this unit.

Additional uses are certain to be found for the vacuum tube voltmeter after one has become more familiar with its action and when specific tests are desired to be made which require an accurate indication without placing a load on the circuit.



Fig.18 A representative vacuum tube voltmeter.

Fig. 19 shows a rather unique design of voltmeter now on the market. This particular instrument is a voltmeter-ohmmeter, but it was not included under that subject in Lesson 1, as it is fundamentally a vacuum tube voltmeter.

The instrument uses a push-pull electronic vacuum tube voltmeter of new design, the circuit of which is shown in Fig. 19. The two tubes  $V_1$  and  $V_2$  are linked by means of a common high resistance  $R_{40}$ . Because of this coupling, any change in the input voltage to the grid of  $V_1$  changes the cathode bias of  $V_2$ , and, as a result, the change in the plate current of  $V_1$  is accompanied by a simultaneous change in the plate current of  $V_2$  in the opposite direction. The differential voltage thus developed across the load resistors  $R_{45}$  and  $R_{45}$  is applied to the meter, which is calibrated in terms of the voltage applied to the input and in terms of the resistance being measured when the instrument is used as an ohmmeter.

PARTS LIST

PART	DESCRIPTION	PART NO.	DESCRIPTION	PART NO.	DESCRIPTION	PART NO.
R1-R10	150 megohm ± 5%	VO-R110	10 megohm ± 5%	VO-R111	RE2	15,000 ohm
R11-R12	5 megohm ± 5%	VO-R100	2.5 megohm	VO-R112	RES	4,000 ohm
R13-R14	3 megohm ± 5%	VO-R101	500 ohm ± 5%	VO-R113	C1, C2	VO-PC100
R15-R16	3 megohm ± 5%	VO-R102	3,000 ohm ± 5%	VO-R114	C3	400 volt. air per
R17-R18	1.5 megohm ± 5%	VO-R103	3,000 ohm ± 5%	VO-R115	S1	1000 volt. air
R19-R20	500,000 ohm ± 5%	VO-R104	20,000 ohm ± 5%	VO-S121	S1	Range switch
R21-R22	100,000 ohm ± 5%	VO-R105	2,000 ohm	VO-S122	S2	Volt-Ohm switch
R23-R24	100,000 ohm ± 5%	VO-R106	2,000 ohm	VO-S123	S3	Polarity switch
R25-R26	100,000 ohm ± 5%	VO-R107	100 ohm ± 5%	VO-S124	S4	Line switch
R27-R28	100 ohm ± 5%	VO-R108	1,000 ohm ± 5%	VO-T101A	T1	Power transformer
R29-R30	1,000 ohm ± 5%	VO-R109	30,000 ohm ± 5%	VO-T101B	Model 20-A	
R31-R32	30,000 ohm ± 5%	VO-R111	1 megohm ± 5%	Kodal 20-B		
R33-R34	100,000 ohm ± 5%	VO-R112	1 megohm ± 5%	Burgess Type 72BP		
R35-R36	1 megohm ± 5%	VO-R109	1 megohm ± 5%	Eveready Type 72E		

NOTE: VOLTAGES INDICATED ARE THE ACTUAL OPERATING VOLTAGES WITH NO VOLTMETER ATTACHED TO THE RANGE SWITCH. VOLTAGE RECEPT TO GROUND IS IN VOLTAGE 1/17 VOLTS - VOLTS-OHMS SWITCH IN THE VOLTS POSITION.

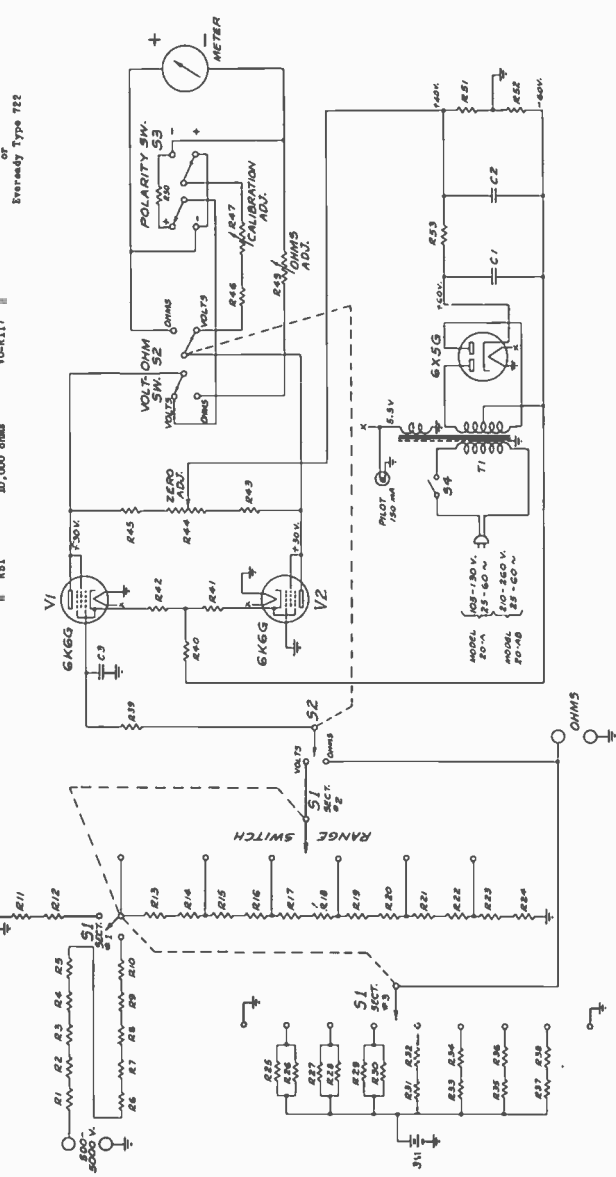

Fig.19 A combination electron voltmeter-ohmmeter.

In addition to the push-pull action, a high degree of self-regulation is obtained as a direct result of the high value of coupling resistance  $R_{40}$ . This is analogous to the regulating effect secured through the use of self-bias, but because  $R_{40}$  is approximately 100 times as large as the value of cathode resistance which it is possible to use in conventional circuits, the self-regulating action is correspondingly increased. At the same time, the excessive loss of sensitivity normally experienced when using such a high cathode resistance, is eliminated in this instrument because of the balanced nature of the circuit. A controlled amount of inverse feedback to obtain independence of tube characteristics is secured by means of the two resistors  $R_{41}$  and  $R_{42}$ .

A principal factor limiting the maximum input resistance of DC vacuum tube voltmeters has been the problem of reducing the grid current and the so-called "contact potential" error to a low value. In this instrument, this problem has been solved successfully by the choice of a suitable tube type, the use of a very high cathode resistance, and by operation at a low plate voltage.

The ohmmeter circuit utilizes the vacuum tube voltmeter described above to measure the ratio between the voltage across the unknown resistance and one of seven standard resistors. The latter range in value from 10 ohms to 10 megohms so that multiplying factors from  $R \times 1$  to  $R \times 1,000,000$  are provided.

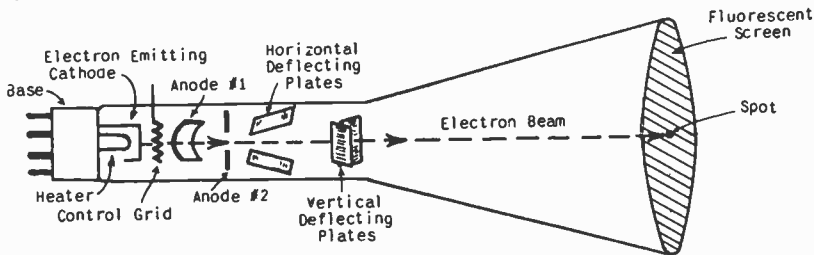

Fig.20 Principal elements of a cathode ray tube.

5. OSCILLOSCOPES. The oscilloscope has proved to be one of the greatest time-saving instruments introduced to the servicing field. It is built around the cathode ray tube, which, in effect, is a device for converting electric currents and voltages into visual images. The value of such an instrument can immediately be recognized. With it, it is possible to "see" the shape of the voltage curve of any circuit we wish to study; for example, the shape of a modulated R.F. voltage, or the sharpness of tuning in a resonant circuit.

This brief discussion of the function of a cathode ray tube can be supplemented by reference to Figs. 20 and 21. First, the tube contains an electron emitter very similar to that used in an ordinary radio vacuum tube. Either the directly or indirectly heated cathode type of electron emitter may be used, the indirect method being more popular. When the heater-cathode construction

is used, the emitting surface on the cathode is generally flat and is coated with an oxide preparation which emits a bountiful supply of electrons. Those electrons liberated from the cathode are drawn toward the highly positive voltage on anode  $A_2$  at a high velocity. The speed of the electron movement toward the anode  $A_2$  is dependent upon the voltage difference between  $A_2$  and the cathode. The electrons, upon moving away from  $A_2$ , are converted into a narrow beam, and it is for this reason that the device is called a "cathode ray" tube.

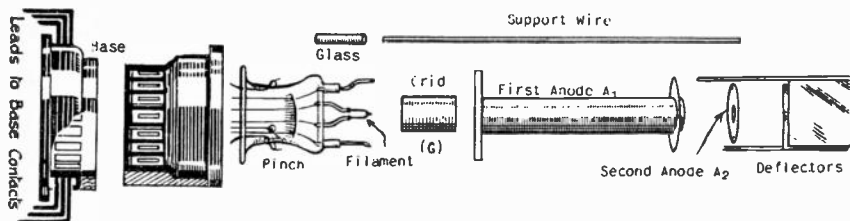

Fig. 21 A dissected view of a cathode ray tube.

Even though the anode  $A_2$  is positive with respect to the cathode, it is not called the "plate" in a cathode ray tube. This anode is not for the purpose of stopping the electrons; in fact, it has a small hole in the center so as to permit the electrons to pass through it and continue on to the screen.

As the electrons are attracted to the second anode  $A_2$ , they pass through the control grid  $G$  and the anode  $A_1$ . The control grid is maintained at a negative potential with respect to the cathode, and the anode  $A_1$  is positive with respect to the cathode. The voltage on  $A_1$  is much less than that on  $A_2$ , so  $A_1$  is negative with respect to  $A_2$ . The bias voltage applied to the grid is made variable and serves as a means of controlling the "intensity" of the cathode ray beam. The intensity of the beam is determined by the number of electrons contained in the beam. The brilliance of the spot or image produced on the screen is a direct function of the number of electrons striking it, and the force of their impact; so changing the control grid voltage has the effect of varying the brilliance of the image. Making the control grid more negative with respect to the cathode decreases the number of electrons permitted to pass through it and into the anode  $A_1$  (decreases brilliance); whereas, making the grid less negative allows more electrons to pass and the image becomes brighter. The control grid is in the form of a small cylinder inserted over the electron emitter and fitted with an internal circular plate. This internal plate has a small round hole in the center to allow the passage of the electrons. Its position and size relative to the other elements are apparent in Fig. 22. The potentiometer  $P_1$  controls the grid bias voltage.

If the electrons were not focused properly so as to constitute a small ray when striking the screen, the image produced would not be easily distinguishable. An unfocused spot appears very



large on the screen and has a halo around it. An attempt to trace a waveform with this spot results in extremely wide lines of non-uniform width and it will not be possible for the electrostatic or electromagnetic fields to deflect it properly and secure an image of any value. It is quite essential to prevent this diversion of the electrons from the cathode, because it is desired to

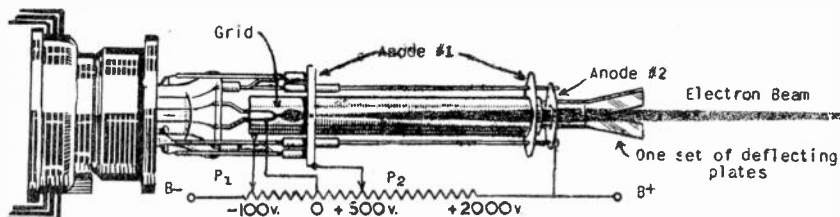

Fig. 22 Illustrating the path of the electrons in a cathode ray tube.

concentrate the electron stream into a fine, sharp point when it strikes the screen of the tube, thereby producing only a tiny spot. If this beam concentration were not obtained, the multiplicity of electrons striking the screen would cause it to fluoresce over a large portion of its surface, and it would be impossible to observe the desired waveforms thereon.

The electron focusing system in a cathode ray tube consists of the voltage relation between the anode  $A_1$  and anode  $A_2$ . The voltage difference between the grid and the cathode controls the number of electrons permitted to pass through the grid and into the influence of the focusing system. The anode  $A_1$  is a hollow

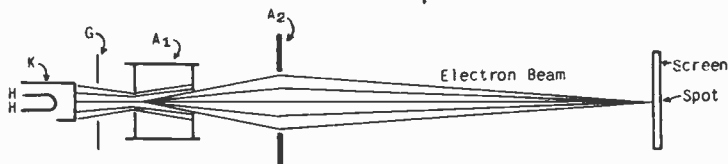

Fig. 23 The electron focusing system of a cathode ray tube.

cylinder with a small hole in each end, as shown in Fig. 22. The line drawing in Fig. 23 also illustrates this construction. Those electrons which are permitted to pass through the control grid  $G$  enter the hollow cylinder and tend to diverge as shown by the diagram. The electrons are also affected by the higher potential on anode  $A_2$ ; hence, they are attracted through the small hole in the opposite end of  $A_1$  and into the field of attraction possessed by  $A_2$ . The potential difference between  $A_1$  and  $A_2$  causes the electron beam to converge into a narrow ray, becoming a fine point as it strikes the screen. Potentiometer  $P_2$  in Fig. 22 serves as the focusing control. This treatise on electron focusing is very brief, the detailed discussion being reserved for a future lesson.

The entire unit, consisting of the focusing system, electron emitter, and intensity control, is generally called the "electron

gun". Its purpose is to "shoot" the narrow electron beam along the length of the tube to the fluorescent screen. The extremely high potential on anode  $A_2$  causes the electrons to be accelerated with sufficient velocity that they will continue on through the length of the tube to the screen after passing through the small hole in the center of anode  $A_2$ . The inner surface of the end of the cathode ray tube is coated with a chemical material which glows or fluoresces when the electrons strike it, thus producing a bright spot of light. Several different materials are used for this fluorescent screen; the one most generally employed being zinc silicate, generally known as "willemite". A willemite screen glows with a bright, yellow-green color. Other colors are possible by the use of different chemicals. This chemical coating is very apt to be damaged by a continued electron bombardment of high intensity at one spot for any length of time; hence, the beam should not be allowed to remain stationary because it is apt to result in disintegration of the fluorescent material. Should the screen become damaged in this manner, a black spot will be observed, which hinders the usefulness of the tube.

As the electron beam passes from the "electron gun" to the fluorescent screen, it passes between two sets of deflecting plates known as the vertical deflecting plates and the horizontal deflecting plates. In order to better understand the action of these plates, let us examine Fig. 24.

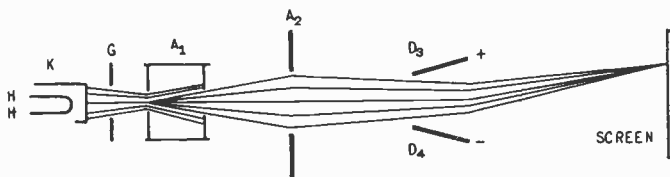

Fig. 24 Showing the function of the deflecting plates.

Fig. 24 shows the addition of one pair of deflecting plates to the electron gun. If these two plates are at the same potential; that is, if no voltage difference exists between them, the electron stream is unaffected by their presence. However, if a difference of potential does exist between  $D_3$  and  $D_4$ , the electron stream will be deflected toward the plate which is more positive ( $D_3$  in Fig. 24). (A positive charge attracts electrons, which are negative; while a negative charge repels. Both plates, therefore, bend the electron beam up as shown).

Assume that a cathode ray tube has both pairs of deflecting plates connected to a DC source through potentiometers as shown in Fig. 25. The center position of the "electron spot" on the luminous screen, with zero voltage on both axes, is shown at B. At C,  $E_1$  has been raised from zero, and it can be seen that the electron beam has been deflected upward and the spot now appears near the top of the screen. At D,  $E_1$  has been returned to zero, and  $E_2$  raised. A horizontal deflection is obtained. The directions of

deflection, BC and BD, are essentially at right angles, due to the physical position of the electrostatic deflecting plates in the cathode ray tube. At E, both  $E_1$  and  $E_2$  are impressed simultaneously, and with deflection on both axes, the spot has assumed the position resulting from the displacement in two directions.

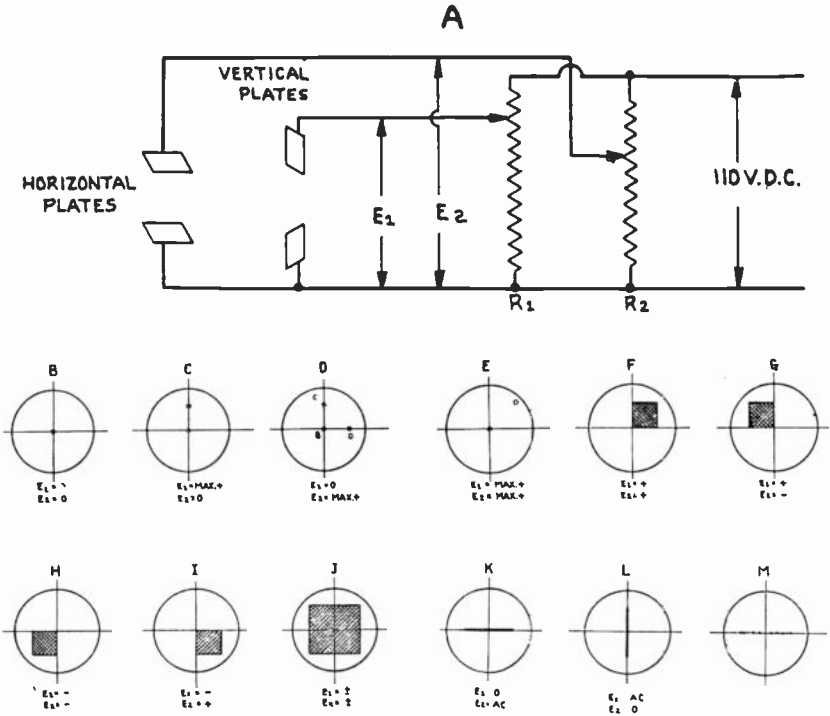

Fig. 25 Illustrating both vertical and horizontal deflection.

It is readily apparent that by proper choice of  $E_1$  and  $E_2$ , the spot may be made to assume any position within the shaded area of F. If the supply to  $R_2$  is reversed, the beam will move to the left of center position as the  $E_2$  voltage is increased from zero, and the shaded area of G applies. H and I need no explanation, while J shows in shade, the area the spot can be made to cover by changing polarity and value of the impressed voltages  $E_1$  and  $E_2$ . Now assume that a 2-cycle AC voltage is impressed at  $E_2$  ( $E_1 = 0$ ). The spot will be seen to traverse the screen (see M) four times a second, and if the voltage is sinusoidal, the spot will move rapidly in the center of its travel and slowly at each end. If the 2-cycle source is replaced by a higher frequency (20 cycles or more) the spot will no longer be seen, but instead will cause a horizontal line to appear as shown at K. A similar voltage impressed on  $E_1$ , (with  $E_2 = 0$ ), gives a vertical line as

in L. It should be borne in mind that the electron stream is always causing only a small spot to become luminous (assuming correct focus, etc.) but due solely to the illusion of persistence of vision (neglecting screen retentivity), the course of the spot appears as a line or image. A familiar analogy is the motion picture, in which a rapid series of still pictures gives apparent motion.

The shape of the pattern on the end of the tube depends on the waveforms of the applied voltages, their frequencies, and phase relationship. The following brief study of these patterns or "Lissajous figures" is made with particular attention to their development, their use in identifying frequency ratio, and the effect of phase shift.

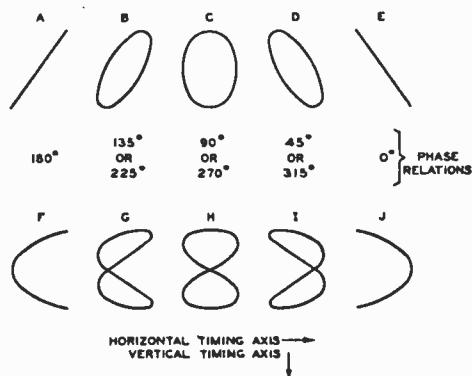

Fig. 26 Various patterns obtainable on the screen of an oscilloscope illustrating different phases and frequency relationships.

The various patterns shown in Fig. 26 are obtained as follows: When a sine wave voltage is applied to the vertical pair of deflecting plates, and an identical voltage 180 degrees out of phase is applied to the horizontal deflecting plates, the resultant pattern will be a straight line having a 45-degree slope, as shown at A. If the two AC voltages are of the same frequency and amplitude, but the phase relation is such that one voltage leads by 135 degrees or 225 degrees, the resultant pattern will be that as shown at B. If these two voltages differ in phase by 90 degrees or 270 degrees, but are of the same amplitude, the resultant pattern will appear on the end of the tube as a perfect circle. Should one voltage be slightly different in amplitude than the other, a distorted circle will be formed as shown at C in Fig. 26. If the phase relation between the two applied voltages is such that one voltage leads by 45 degrees or 315 degrees, the resultant pattern will be that shown at D. If there is no phase difference between the applied voltages, a straight line having a 45 degree slope in the direction shown at E will be obtained. From A to E inclusive in Fig. 26, the appearance of the resultant pattern on the end of the tube is illustrated where the wave shapes, relative amplitude, phase relation, and frequencies of the two deflecting voltages are known. Conversely, from this pattern, the frequency and phase relations of the two deflecting voltages can be determined. Where the

waveform is known for one of the deflecting plates, the waveform of the other can be obtained by graphical analysis.

From A to E in Fig. 26, the two deflecting voltages were considered to be of the same frequency; that is, the frequency ratio is 1:1. When the frequency ratio of the voltages is 2:1, the wave shapes become as those shown from F to J in Fig. 26. For these patterns, the frequency of the horizontal sweep voltage (horizontal timing axis) is twice as great as the frequency of the vertical sweep voltage (vertical timing axis).

As the ratio of the frequencies increases, the pattern becomes more complex, and to obtain a clear comprehension of the patterns obtained on the tube, it is necessary to follow through a graphical analysis. We do not think it advisable to deviate from our general topic to discuss material of this nature; however, it will be explained in detail in a future lesson.

6. WAVEFORM OBSERVATION. The most common methods of using a cathode ray tube consist of impressing the voltage to be observed on the vertical deflecting plates and a voltage varying with time in a linear (straight line) fashion on the horizontal plates. This latter voltage is obtained from a special type of oscillator circuit called a "sawtooth" oscillator. The voltage output has a sawtooth waveform such as shown in Fig. 27. This type of voltage, when applied to the horizontal plates, is often called the "linear sweep voltage" and is for the purpose of observing the true waveform of the AC signal on the vertical axis without distortion. From Fig. 27, it can be seen that the sawtooth voltage starts at zero and rises at a uniform rate to a peak value as time progresses. After the peak is reached, it drops instantaneously to zero. What actually happens is that the spot starts at the left side of the screen and moves across it to the extreme right. It then snaps back to the starting point in such a short time that the material on the screen does not glow. The operation repeats continuously; hence, it may be said that the horizontal sweep voltage varies "linearly" with time when a sawtooth deflecting voltage is employed.

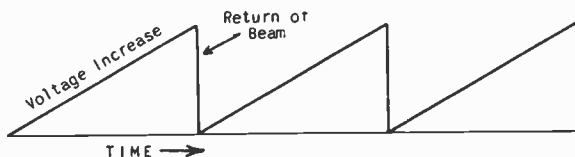

Fig. 27 A sawtooth or linear sweep voltage.

Suppose that a 60-cycle sine wave AC voltage is connected across the vertical plates of the cathode ray tube and that the sawtooth linear sweep applied to the horizontal plates is adjusted so that it traces across the screen from left to right at a rate of 60 times per second. A single cycle of the voltage applied to the vertical plates will appear on the screen of the tube as shown in Fig. 28A. If the pattern is to remain stationary and readily

observable, the rate of the sweep circuit must be in absolute synchronism with the frequency of the voltage being observed. This is accomplished in practice by using a little current from the AC source to control the speed or timing of the voltage pulses from the sawtooth oscillator. The controlling or "locking" circuit holds the pulses of the linear sweep in constant ratio to the observed wave, resulting in a steady pattern on the screen.

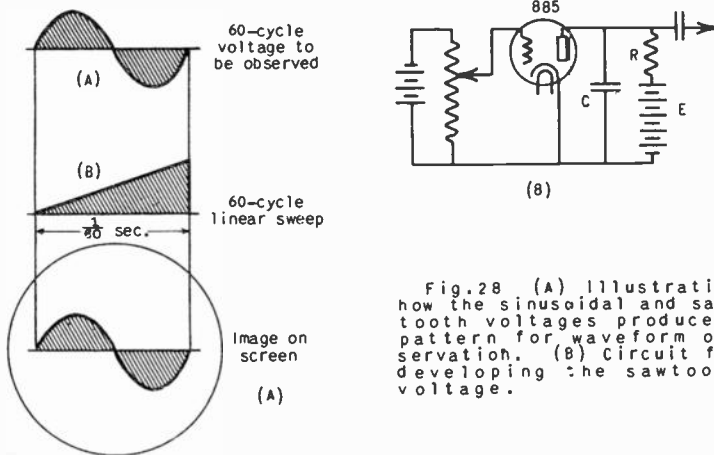

Fig. 28 (A) Illustrating how the sinusoidal and sawtooth voltages produce a pattern for waveform observation. (B) Circuit for developing the sawtooth voltage.

It follows that if the linear sweep is adjusted to a 30-cycle rate, and 60 cycles is applied to the vertical plates, two complete cycles will be seen on the fluorescent screen.

From the above discussion, it can be seen that the observance of waveforms on a cathode ray tube depends to a great extent upon the action of the horizontal sweep circuit. For that reason, we believe an investigation into the methods of obtaining this voltage is advisable at this time.

In early forms of the oscilloscope, a "relaxation oscillator" was used. This type of sawtooth wave generator is no longer used, so we will not describe it at this point. Modern instruments now use some form of circuit employing the type 885 gas discharge tube. This tube employs a heater and a cathode for the purpose of securing an electron emission the same as an ordinary vacuum tube. It contains an inert gas which will ionize when the voltage between the cathode and plate reaches a certain potential. The plate voltage at which this ionization occurs depends upon the bias voltage applied to the grid. In other words, the striking or breaking down potential of this tube is a function of the applied grid potential. When a definite voltage is applied to the grid of the tube, ionization will occur when a certain plate potential is reached. A simplified diagram showing the circuit of a typical sawtooth oscillator employing an 885 discharge tube is shown in Fig. 28B. The plate supply voltage E charges the condenser C and applies a potential to the plate of the tube through the resis-

tance R. As the condenser-charging current passes through the resistance R, the voltage across the condenser C rises, building up linearly from minimum to maximum. The instant the potential difference between the plate and cathode of the tube attains the ionization value, the gas within the tube becomes ionized. Practically a short-circuit is thus formed across the condenser because of the resistance of the tube from cathode to plate is decreased to an exceedingly low value. The condenser discharges through the tube, and the voltage across the tube drops; hence, the output voltage from the sawtooth oscillator is instantly returned to minimum. Charging current again starts to flow through the resistance and builds up the voltage across condenser C, only to again discharge as the gas in the 885 ionizes. The sawtooth voltage output of the 885 oscillator can be applied directly across the horizontal plates of a cathode ray tube if special current-limiting circuits are used in conjunction with it; however, the more general design of these oscillators is to use a conventional circuit as shown in Fig. 28B, then amplify the output voltage through a resistance-coupled amplifier.

The purpose of the biasing control arrangement on the grid of the 885 is to definitely fix the plate-to-cathode potential of the tube at which ionization occurs. In some commercial sawtooth oscillator circuits, the bias voltage is fixed so that the maximum value of the sweep voltage output will always be the same regardless of frequency. Others incorporate a potentiometer across the biasing source in order to provide an amplitude control for the output voltage.

Since the frequency of the sawtooth is dependent upon the resistance and capacity in the plate circuit of the 885, a range switch and vernier adjustment are generally provided so as to secure the correct frequency of horizontal timing voltage. The range change switch inserts different size condensers in the circuit, and the vernier control changes the size of the series resistance.

It is safe to say that practically all commercial oscilloscopes are the same, insofar as the circuits are concerned. There are different size cathode ray tubes, varying from 1" to 12" in diameter. This diameter refers to the effective diameter of the fluorescent screen. The main advantage of the larger diameter tube lies in the larger visual image that can be obtained, and the closer adjustments which can be secured through this larger image.

We illustrate in Fig. 29 the schematic diagram of a typical oscilloscope. This particular unit uses a type 906 cathode ray tube which has a 3" screen. The DC voltages required are obtained from two separate rectifier circuits. A full-wave type 80 rectifier from the low voltage portion of the power transformer secondary supplies the voltages for the vertical and horizontal amplifier tubes. Another type 80 rectifier tube connected to the high voltage portion of the power transformer secondary acts as a half-wave rectifier, and supplies the anode voltages for the cathode ray tube.

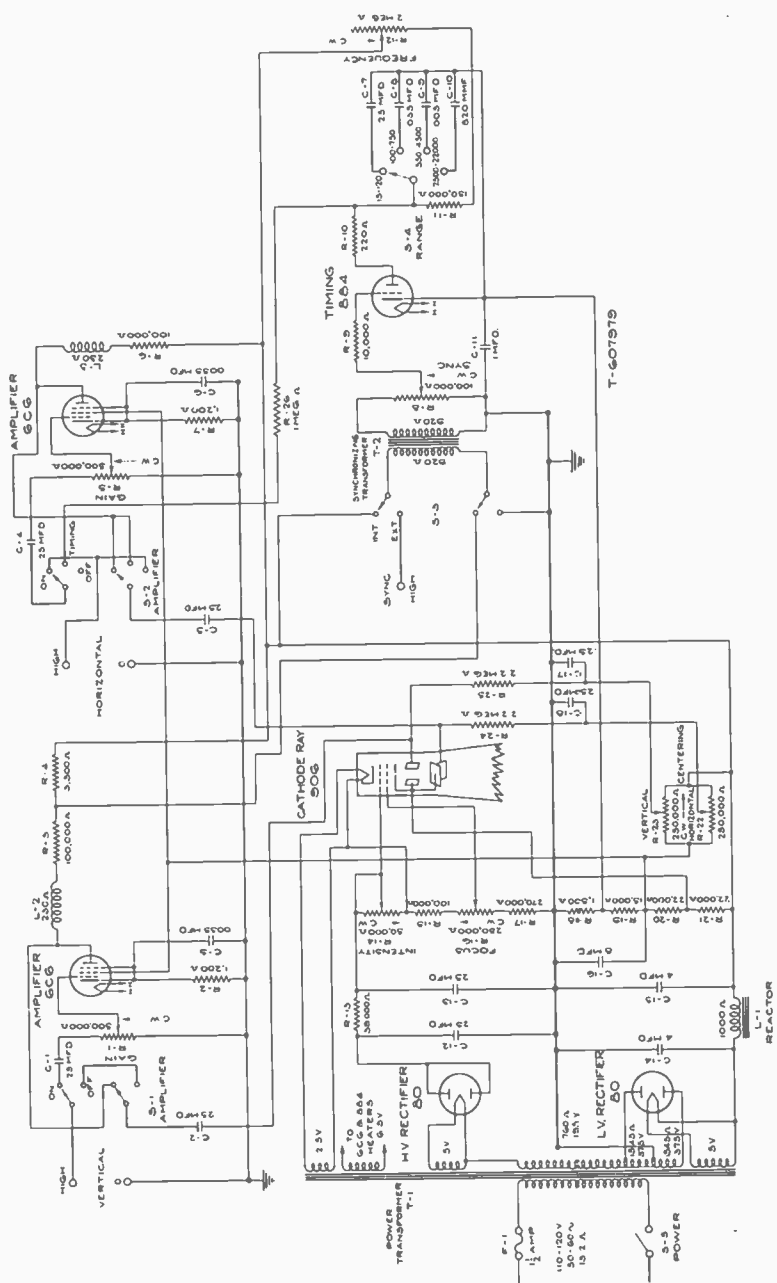

Fig.29 Schematic diagram of a typical oscilloscope.



Referring to Fig. 29, you will note that the negative side of the low voltage supply is also the positive side of the high voltage supply. *This common connection is grounded.* Anode #2 and one plate each of both the horizontal and vertical deflecting plates are connected to a point near the highest positive voltage available. The cathode is connected near the most negative voltage available. This gives the high voltage necessary between cathode and anode #2. The control grid is made negative to the cathode, and the voltage on this grid is controlled through an "Intensity Control". This, as we learned in the preceding paragraphs, controls the intensity of the spot on the fluorescent screen. At this point, we caution against too strong a spot being used. The fluorescent material which makes up the screen can be "burned" if the beam is too strong. For that reason, it is always best to keep the beam at a minimum strength.

Anode #2 is connected to a tap on the high voltage "voltage divider" through a variable control. This control varies the voltage ratio between anode #1 and anode #2, and in this manner, controls the focusing of the beam on the fluorescent screen. The sharper the focus of the electron beam, the clearer the image obtained.

Due to the effect of stray inductive and magnetic fields within the instrument, some means of centering the electron beam must be provided. In this case, it is accomplished by providing a variable voltage on the deflecting plates which are not connected together. The horizontal and vertical centering controls consist of potentiometers connected in parallel with that portion of the voltage divider which supplies the common deflecting plates. Upon examining the circuit, we see that the voltage between either set of plates can be made equal to each other, or the free plate in each instance can be made higher or lower in voltage than the common plate.

The sawtooth oscillator circuit consists of an 884 tube connected in the conventional circuit described previously in this lesson. Means are provided for synchronization through a transformer and switch arrangement. In order to obtain a stationary pattern on the screen of the cathode ray tube, it is necessary that the sawtooth oscillator be in synchronism with the voltage being observed. Two methods of synchronization are provided. With the synchronizing switch in the internal position, the frequency of the sawtooth oscillator is synchronized with the output of the "Vertical Amplifier". With the switch in the "External" position, the sawtooth oscillator may be synchronized with any external source. Control of the amplitude of the synchronizing voltage applied to the grid of the 884 tube is obtained through the "Synchronizing" control. This is a potentiometer in the secondary circuit of the synchronizing transformer.

Before being supplied to the horizontal deflecting plates of the cathode ray tube, the output of the sawtooth oscillator is amplified through the "Horizontal" amplifier. This amplifier is a resistance-coupled stage of amplification using a 6C6 tube. The source of timing frequency may be selected by a switch in the

input circuit of this amplifier. With the switch in the "On" position, an external timing voltage is used. This is for such purposes as "Single Trace" alignment, utilizing a frequency modulated signal generator, which will be described later in this lesson. With the switch in this position, the timing voltage is amplified through the horizontal amplifier. When the amplifier switch is in the "Off" position, the external sweep voltage is applied directly to the horizontal deflecting plates of the cathode ray tube. When the switch is in the "Timing" position, the internal sawtooth oscillator is used. The signal is amplified through the "Horizontal" amplifier before it reaches the horizontal deflecting plates. Control of the amplitude of the horizontal or timing voltage is obtained through the use of a gain control in the grid circuit of the horizontal amplifier. This control is not used when the external timing voltage is applied directly to the cathode ray tube. (When the switch is in the "Off" position.)

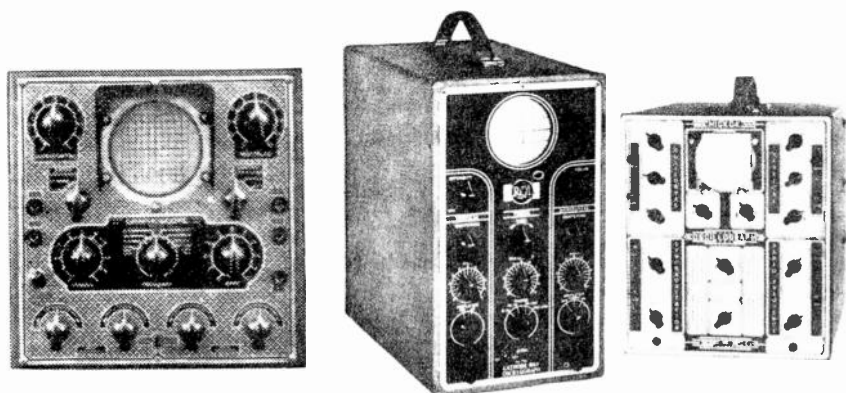

Fig.30 Photographs of commercial cathode ray oscilloscopes.

A vertical amplifier is also provided in this instrument to amplify those voltages of insufficient amplitude to provide a good image on the cathode ray tube screen. A switch in the circuit between the amplifier grid and the vertical input binding posts, provides a means for disconnecting the amplifier from the circuit. With the switch in the "On" position, the amplifier is connected between the input posts and the vertical deflecting plates of the cathode ray tube. With the switch in the "Off" position, the input voltage is connected directly to the vertical deflecting plates. Control of the amplitude of the voltage applied to the amplifier is obtained through the use of a potentiometer in the grid circuit. A blocking capacitor in the grid circuit also prevents any DC current in the circuit being investigated from affecting the operation of the amplifier.

We are illustrating in Fig. 30 some commercial cathode ray oscilloscopes. These are shown to acquaint you with the general appearance of these instruments. Controls and connections are

practically identical on all instruments, so a lengthy description is not necessary.

Some of the many uses for the cathode ray oscilloscope are listed below. As we advance through succeeding lessons in this unit, we will study the method of using the oscilloscope for these measurements.

1. AC Voltmeter. By calibration of the cathode ray oscilloscope, it is possible to measure AC voltages, using the amplitude of the wave as an indication.
2. To observe the performance of Audio Amplifiers. By observing the waveform of the output of the amplifier.
3. Comparison of frequencies. This allows the calibration of audio oscillators to a very high degree of accuracy.
4. Measuring the dynamic characteristics of vacuum tubes is another cathode ray oscilloscope application of considerable importance.
5. It is possible to determine the magnetic characteristics of the iron core in an A.F. choke or transformer to a high degree of accuracy with an oscilloscope.
6. Determination of the harmonic content in complex waves can be observed.
7. Vibrators and power supplies used in auto radios can be accurately checked by observing the output waveform.
8. The overloading of any amplifying stage can be determined by the use of the oscilloscope.
9. The waveform of the output voltage from a detector in a receiver can be inspected, thus revealing the character of the demodulated wave.
10. Phase distortion in any amplifier circuit can be very easily detected by use of the oscilloscope.
11. Condenser power factor tests are made.
12. Hum measurements in the audio circuit can be made by observance of the pattern on the cathode ray screen.
13. All types of attenuators, tone controls, etc., can be tested for noise, partial short circuits, etc.
14. Any waveform, whether A.F., I.F., or R.F. can be observed on the tube to determine its exact appearance and the extent of the harmonic distortion, if any.
15. Measuring percentage of modulation in transmitters.
16. Visual alignment of tuned circuits.

7. FREQUENCY-MODULATED SIGNAL GENERATORS. In later lessons in this unit, you will study the details of alignment by several different methods. It is not necessary at this time to enumerate the various methods, but we feel that a short explanation of the visual method of alignment will help you in your study of the Frequency Modulated Signal Generator in the following pages.

When a radio station broadcasts a program, it emits "sidebands" as well as the R.F. carrier. Let us assume that a station is broadcasting on 600 kc. and is sending out a 3,000 cycle note. Besides the 600 kc. signal, the receiver must also receive the

upper and lower sidebands (600 kc. plus 3 kc., and 600 kc. minus 3 kc.; or 603 kc. and 597 kc.); thus, when these R.F. signals are beat with the oscillator in a superheterodyne, we would get 175 kc. (if this is the I.F. peak), 178 kc. and 172 kc. Now let us assume the station is transmitting a 5,000 cycle note. This would result in a 170 kc. and a 180 kc. I.F. signal in addition to the 175 kc. frequency in the plate circuit of the first detector. Now, the question arises, if both the 3,000 cycle note and the 5,000 cycle note were originally of the same relative intensity, what would their relative intensities be when they reach the second detector?

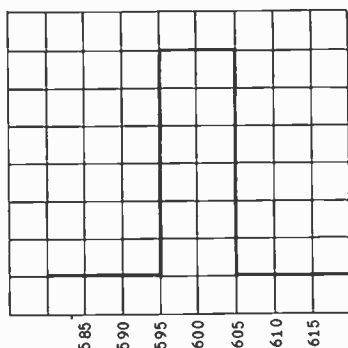

Fig.31 An ideal resonance curve.

As each radio station in the broadcast band is placed 10 kc. apart, each sends sidebands up to approximately 5 kc. on both sides of its carrier frequency. Thus, a perfect response curve on a receiver would look like Fig. 31, where the horizontal lines represented relative "set acceptability" and the vertical lines represents frequency. You can see that such a set, when tuned to 600 kc. would accept all sidebands between 595 kc. and 605 kc. with equal intensity, but would completely reject all other signals.

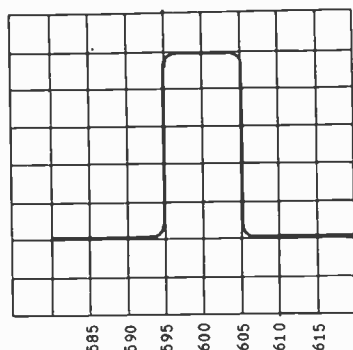

Fig.32 The best response curve obtainable.

Unfortunately, no set has ever been built with such an acceptability curve and the best would be as shown in Fig. 32. A poorly designed receiver (such as many of the cheaper sets) would have an acceptability curve like Fig. 33.

Therefore, it is important that the serviceman know not only: (1) that the set is working at peak sensitivity on I.F. and R.F. frequencies; but (2) its relative sideband acceptability, because if the set tunes too sharply, it will cut off most of the high audio frequencies in the radio program. If it tunes too broadly, the result will be "sideband chatter", because it will also receive the high frequency sidebands of the adjacent radio stations.

To solve this problem, visual alignment was developed. This is a system of varying the R.F. frequency over a predetermined bandwidth while keeping the amplitude of the signal constant. Thus, after peaking the receiver using the amplitude modulation method, we swing over to frequency modulation and finish the job adjusting the set's acceptability curve to optimum. Remember, visual alignment is not a "cure-all". It will not make a set with poor I.F. design, work like a high fidelity receiver. However, it will, and does, allow you to adjust each set to its maximum ability to perform properly.

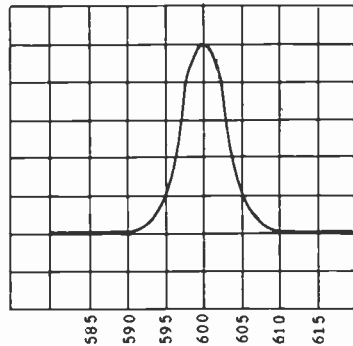

Fig. 33 Response curve typical of cheaper receivers.

In order to make these visual alignments, certain instruments must be used. In addition to the cathode ray tube oscilloscope, a frequency modulated Signal Generator is essential. Such an instrument, as mentioned above, varies the frequency of the signal generator while the *amplitude* of the R.F. output voltage is held at a constant value. You will remember from your earlier studies that with amplitude modulation, the frequency of the R.F. signal remains constant, while the amplitude is varied at an A.F. rate. In frequency modulation, however, the amplitude is held constant, while the frequency of the carrier wave is varied through a narrow band (usually from 20 to 60 kc. wide). In effect, frequency modulation is the same as swinging the tuning dial of the signal generator back and forth very rapidly through a certain frequency range at a smooth and continuous speed. If you started at 1,000 kc., increased the frequency to 1010 kc., reduced it to 990 kc.,

and then returned to 1000 kc., the "frequency modulation" would be 20 kc. wide, (from 990 kc. to 1010 kc.). If the complete change just given were performed in 1 second, the rate of the frequency modulation would be one cycle per second. If performed 10, 30, or 60 times per second, the speed of the frequency modulation would be correspondingly increased. Obviously, it is impossible to manually oscillate the dial of a signal generator at a speed of 30 or 60 complete changes per second; so to accomplish this rapid fluctuation, and also to make the changes smooth and even, some mechanical or electrical device is needed.

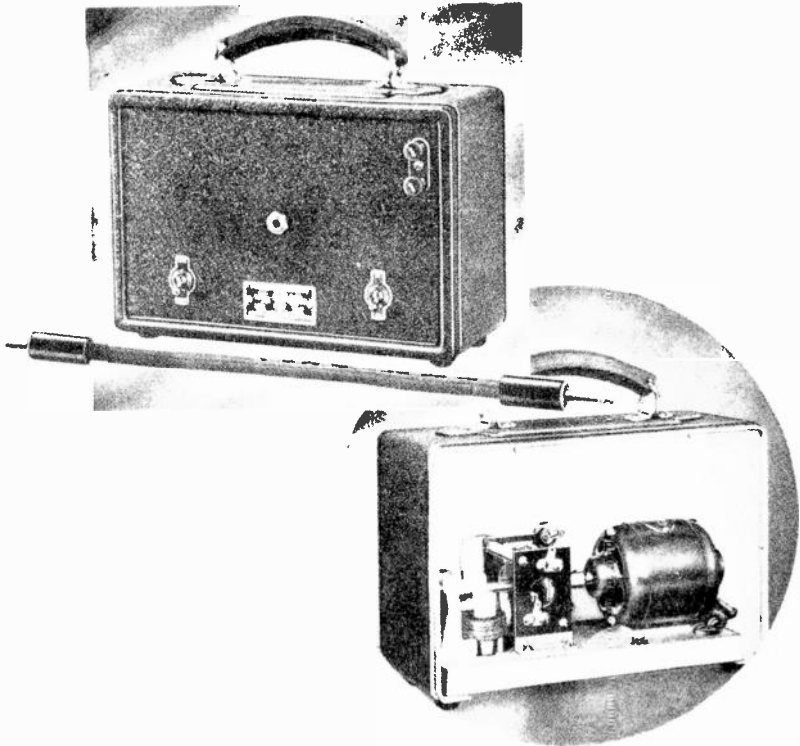

Fig. 34 Photograph of a commercial frequency modulator.

Frequency modulation was obtained in older equipment by rotating a small variable condenser with a miniature motor. The small condenser was connected across the main tuning condenser of the test oscillator and, as its capacity was varied, the resultant total capacity change in the oscillator circuit caused the output frequency to vary in accordance. From our previous study of tuned circuits, it is known that, as the capacity is increased, the resonant frequency decreases; and, as the capacity is decreased, the resonant frequency increases. Rotation of the "frequency-

modulating condenser" causes the condenser's capacity to be rapidly changed from minimum to maximum, then back to minimum, etc., so the total capacity in the oscillator tuned circuit and the output frequency are varied in accordance. The width of the frequency band covered depends upon the percentage of total circuit capacity change. This, of course, is a function of both the size of the rotating condenser and the initial capacity in the oscillator circuit. Assuming the motor-driven condenser to be a given size, the frequency band covered when the oscillator capacity is low will be much greater than when it is high. The reason lies in the fact that no tuning condenser possesses a straight-line frequency characteristic over its entire range of capacity variation; hence, one degree of rotation near minimum capacity gives a greater frequency change than one degree of rotation near maximum capacity.

Fig. 34 shows a picture of this type of equipment. It consists of a small motor, a variable capacitor, and an AC generator, all mounted on an integral shaft. The AC generator is used for a synchronizing voltage supply, to insure synchronization between the rate of frequency modulation and the sawtooth oscillator.

The bandwidth, or range through which the frequency is varied, should be constant for any one setting of the test oscillator frequency so as to permit accurate alignment of the frequency response through the I.F. or R.F. amplifier under test. Since a motor-driven condenser does not "wobble" or modulate the test oscillator signal over a constant range at all frequencies, it has been discarded in most modern apparatus.

Present-day units accomplish the necessary frequency modulation at a constant bandwidth regardless of the test oscillator frequency. Considerable advantage is gained with this characteristic, mainly because it permits an accurate indication of the frequency band passed through the tuned circuit under test. Calibrated celluloid scales may then be placed over the screen of the cathode ray tube, and the operator is thus provided with a stationary and calibrated image of the frequency response of the amplifier under test, whereon he may see the effect on selectivity and sensitivity of each change he makes.

Fig. 35 shows the schematic diagram of a typical Electronic Frequency-Modulated Signal Generator. A photograph of the instrument is shown in Fig. 36. This, like many modern signal generators, operates on a beat frequency principle.

In this instrument, a standard signal generator is combined with a frequency-modulated generator to cover all the requirements of radio service work. By means of the modulation switch, the unit may be used to supply an unmodulated R.F. signal; an R.F. signal, modulated at 400 cycles; or a frequency-modulated signal. Multi-purpose tubes are used to reduce the total number of tubes required.

A fixed R.F. oscillator, consisting of the pentode section of a 6F7 tube and its associated inductance and capacity, generates a constant frequency of 800 kc. A pickup coil coupled to this tank circuit, feeds energy from this oscillator to grid #4

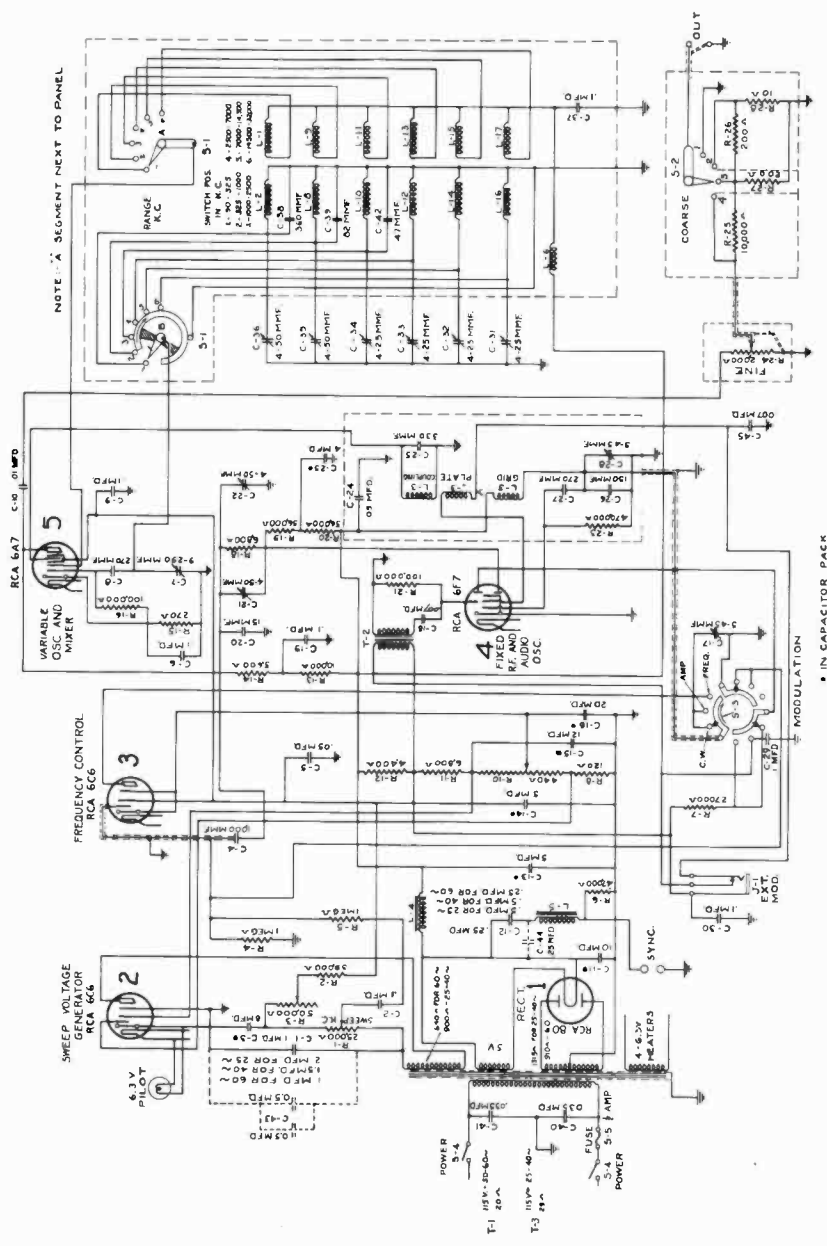

Fig. 35 Schematic diagram of a signal generator with electronic frequency modulation.



of the 6A7 combination oscillator-mixer tube. The triode section of this tube, together with its associated inductances and capacities make up the variable oscillator which is tuned by the variable capacitor  $C_7$ . Due to coupling in the electron stream, there will appear in the output plate circuit, frequencies corresponding to the sum and difference frequencies of the two oscillators. The tuning dial is calibrated directly in kilocycles corresponding to the difference of the two oscillator frequencies up to 7 megacycles. Above 7 megacycles, the sum frequency is used.

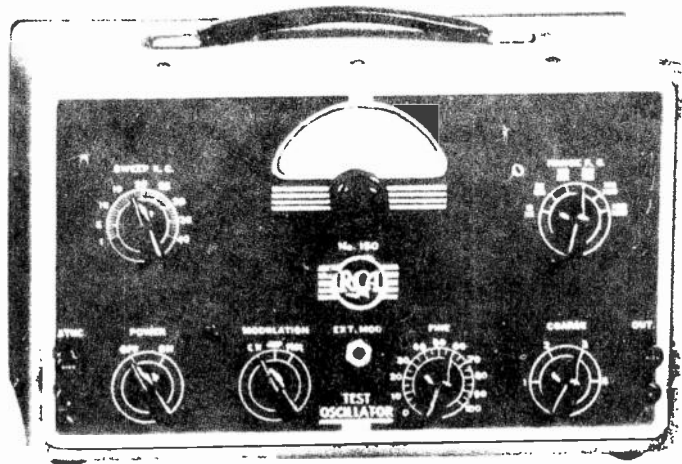

Fig. 36. Photograph of the signal generator whose diagram appears in Fig. 35.

The foregoing description applies for the condition of no modulation on the fixed oscillator. When amplitude modulation is employed, the same conditions exist, except that the triode section of the fixed oscillator tube oscillates at 400 cycles and is coupled externally to the R.F. oscillator section so as to impress audio voltage in series with the plate supply of the R.F. oscillator section. In other words, plate modulation is used. The resultant output voltage from the 6A7 tube is amplitude modulated at a frequency equivalent to the modulation impressed on the fixed oscillator.

When frequency modulation is employed, the above action of the variable oscillator and mixer tubes still holds true, but the signal from the fixed oscillator delivered to the mixer grid #4 is being varied at a low frequency rate (frequency modulation), consequently, the output frequency from the mixer tube will vary in like manner. Frequency modulation of the fixed oscillator is accomplished in the following manner: The work plate of the 6F7, electron-coupled to the fixed oscillator, builds up an out-of-phase R.F. voltage across capacitor  $C_{22}$ , which is coupled to the grid of the 6C6, called the frequency control tube. The plate of this tube is connected directly across the grid tank circuit of

the fixed oscillator. With the voltage of proper phase angle on the grid of the 6C6 (corrected by network  $C_{21}, R_{1a}$ ) the output of this tube appears to the oscillating tank circuit as a shunt inductance. Since the reason for this action is quite involved, we shall not deviate from our subject to explain the theory at the present time. After studying "automatic frequency control" in a later lesson, return to this discussion; you will find its operation more clear after learning the theory of AFC. This inductance, and hence the oscillator frequency, may be varied up or down within limits by raising or lowering the bias on the frequency control tube, and so varying its gain. This is accomplished by

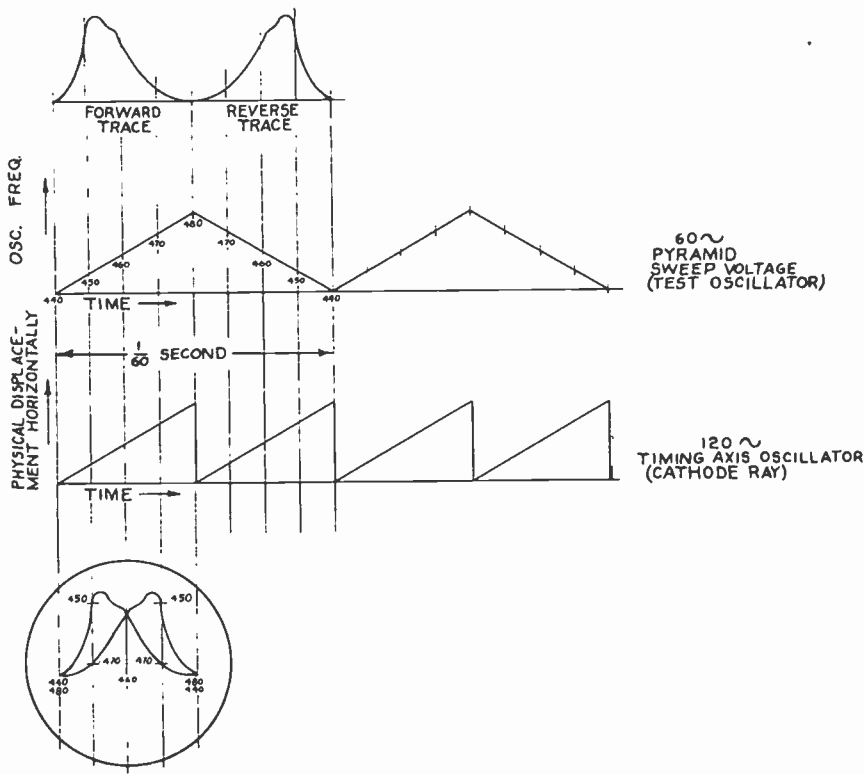

Fig.37 Illustrating how the frequency modulated signal produces the response curve on the oscilloscope.

varying the bias on this tube around a fixed point with a linear 60-cycle pyramid waveform generated by the second 6C6 tube. The pyramid waveform is employed to obtain double image response or the folding back of the forward and reverse resonance traces of a circuit. A brief explanation of double image response follows:

Refer to Fig. 37 and assume that the oscillator timing axis is operating at 120 cycles, exactly twice the frequency of the pyramid sweep voltage, and that the horizontal deflection progresses from left to right on the screen of the cathode ray tube. In  $1/120$  second, the R.F. oscillator frequency progresses from 440 kc. to 480 kc., tracing the response curve on the screen from left to right and controlled horizontally by the timing axis oscillator. At the end of  $1/120$  second, the oscillator frequency starts decreasing, and during the next  $1/120$  second, changes from 480 to 440 kc. At the reversal point (peak of the pyramid voltage) the sawtooth oscillator has caused the horizontal deflection to reach its maximum on the tube screen, drops to zero and returns the beam to the left side of the screen. It then builds up again, tracing the reverse resonance curve (480-440) of the second half of the sweep cycle, thus giving the two super-imposed curves. The two curves are the reverse of each other with respect to frequency except at the point corresponding to the alignment frequency. It will be noted that in the above figure, the assumed circuit under test is purposely shown misaligned so that both traces will be fully visible.

Fig. 38 shows the schematic diagram of a system used by some manufacturers to obtain frequency modulation. As in the system just described, the beat frequency principle is employed. Two R.F. oscillators are used, one fixed tuned to 1650 kc. and the other variable over the range necessary to cover all bands. Both R.F. oscillators use a 6C5 triode metal tube. The output of the fixed oscillator is fed (through an attenuating network) to grid #3 in the 6L7 mixer tube. The output of the variable-frequency oscillator is controlled by a potentiometer, then applied to grid #1 of the 6L7. Since both of the R.F. signals affect the electron stream in the 6L7, the output frequency in the plate circuit will consist of the difference between the two; that is, the beat frequency. By adjusting the variable oscillator, the output frequency may be made to cover any band desired, since the frequency of the fixed oscillator remains constant. It will then be noticed from the wiring diagram that a small variable inductance is in series with the oscillating circuit of the fixed frequency oscillator. This inductance is arranged with a rotating copper vane in its electro-magnetic field. The vane is rotated by a small motor with a speed of 3600 RPM or 60 RPS. As the vane revolves, the inductance of the small coil, and hence the total inductance in the oscillator circuit, is varied over a certain range. By properly choosing the circuit constants, the total frequency change produced by the oscillator circuit can be made over any range desired. When the sweep motor is turned on, the frequency of the "fixed" oscillator varies from 1630 kc. to 1670 kc., with 1650 kc. the mean frequency. This frequency-modulated or "wobbled" signal is then beat against the frequency of the variable oscillator in the 6L7. The output of the signal generator then consists of a 40 kc. modulated voltage equal to the difference between the frequency of the variable oscillator

and the mean frequency of 1650 kc. Regardless of the frequency generated by the variable oscillator, the beat or output voltage will always be modulated 40 kc.; 20 kc. below the resonant or mean frequency, and 20 kc. above. For example, if the output frequency of the signal generator is set to 465 kc. when the sweep motor is turned on, this frequency will change from 445 kc. to 485 kc. Also, if the signal generator is set for an output frequency of 1400 kc., the frequency modulator will cause it to change from 1380 kc. to 1420 kc., the same 40 kc. range. As stated before, this permits accurate adjustment of the tuned circuits being aligned for the desired band-pass characteristic.

Details as to the use of this equipment in the alignment of radio receivers, and the various screen patterns found under varying conditions, will be discussed in a subsequent lesson of this unit.

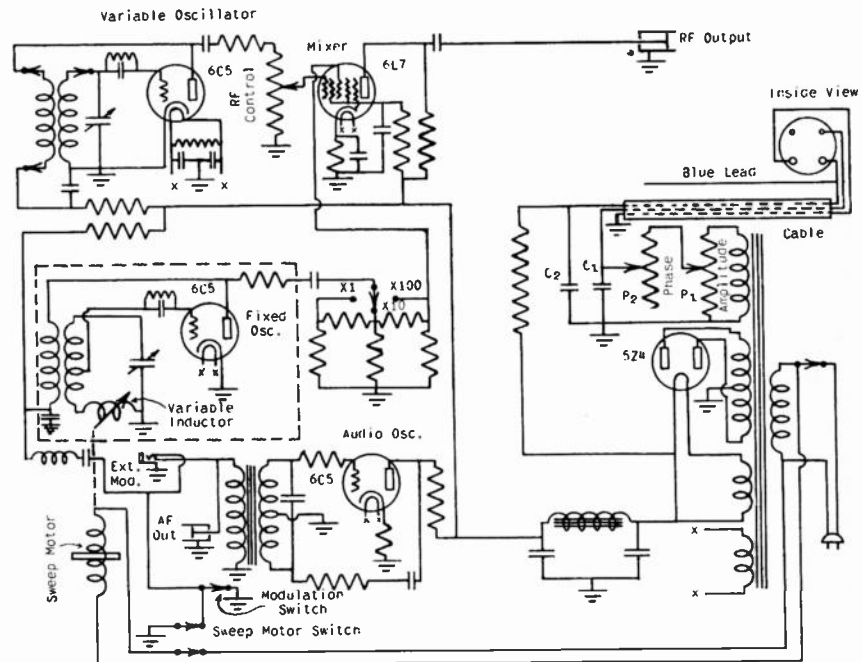

Fig. 38 One method of obtaining frequency modulation.

During our discussion on the various types of signal generators, we have frequently made mention of the calibration of the instruments. Calibration may also be interpreted to mean the accuracy of the instrument for any given frequency setting. If a radio receiver is aligned using a signal generator which is not accurate, an inferior alignment will result, leading to poor performance of the radio receiver. It is important that the service engineer make certain his signal generator is accurate, so that his work cannot be criticized by his customers.

Most commercial signal generators are guaranteed by their manufacturers to be accurate within  $\frac{1}{2}$  of 1% over the entire frequency range. This accuracy, however, may be affected by any number of accumulating causes. In many climates, adverse atmospheric conditions cause the circuit constants to change; in turn, affecting the accuracy of the frequency settings. Also, in time, accumulations of dirt and dust affect the frequency settings. It is also possible that circuit defects may develop within the instrument, which will shift the frequency and thus affect its accuracy. It is wise, therefore, to always check the frequency of the signal generator against some standard which is known to be accurate, before using it for alignment work. There are many methods of checking the accuracy of a signal generator.

Perhaps the most convenient and satisfactory method for checking the calibration of a signal generator on the broadcast range is by using the received signal from a broadcast station. The broadcast station is tuned in on the receiver, then the output of the oscillator connected across the antenna-ground terminals. The frequency of the oscillator (unmodulated) is then adjusted to the same frequency as the broadcast station. As the frequency of the signal generator approaches the frequency of the received signal from the broadcast station, a whistle will be heard from the speaker. At first, this whistle will be of high pitch, then will decrease until no signal is heard, and upon tuning away from the broadcast signal (on the other side), the frequency of the whistle will again become high pitched. In the exact center of this whistle, where no signal was heard, the frequency of the signal generator is exactly the same as the frequency of the broadcast signal. Since the frequency of the broadcast station is known, a check on the signal generator's calibration can be made by referring to its dial reading at this point of "zero beat." Should the dial of the signal generator not be reading exactly the frequency of the broadcast signal, then it indicates that the signal generator is slightly off calibration. If the signal generator is off calibration more than 10 or 20 kc., it is advisable to investigate the cause for the frequency change and remedy the trouble before attempting to use it. By checking the signal generator at several points throughout the broadcast band, its accuracy can be determined.

This method of checking the calibration of the signal generator is satisfactory for the broadcast range, but is far from satisfactory for the I.F. and Short-wave ranges. This is due to the fact that it is unlikely that broadcast signals will be heard at the frequencies where the signal generator is to be calibrated. For calibration of these ranges a very useful instrument is the Piezo-Electric Calibrator, as pictured in Fig. 39.

For checking the intermediate and high-frequency calibration on test oscillators, the Piezo-Electric Crystal Calibrator will be found very satisfactory. This instrument consists of a crystal-controlled oscillator circuit, designed to produce either of two frequencies, 100 kc. or 1000 kc. The desired frequency is

selected by a switch on the front of the instrument. Due to the extreme accuracy of this crystal-controlled circuit, its higher harmonics may be relied upon with great certainty. For example, if it was desired to check the calibration of a signal generator at 300 kc., the third harmonic of the 100 kc. fundamental frequency from the Piezo-Electric Crystal oscillator could be used. Likewise, a check of 400 kc. could be secured with the fourth harmonic,



Fig.39 A piezo-electric  
Crystal Calibrator.

500 kc. with the fifth harmonic, etc. In the short-wave bands, the harmonics of the 1000 kc. fundamental signal from the Piezo-Electric oscillator should be used. The instrument is designed in such a manner that the harmonics constitute a large percentage of the total voltage output; hence, harmonics up as high as the tenth may be used for calibration purposes.



# Notes

*(These extra pages are provided for your use in taking special notes)*



# Notes

*(These extra pages are provided for your use in taking special notes)*

# Notes

*(These extra pages are provided for your use in taking special notes)*

The text of this lesson was compiled and edited by the following members of the staff:

G. L. Taylor  
President and Chief Engineer  
Midland Radio & Television Schools, Inc.

C. L. Foster  
Supt. of Instruction  
Midland Radio & Television Schools, Inc.

C. V. Curtis  
Chief Instructor  
Midland Radio & Television Schools, Inc.

R. E. Curtis  
Technical Drafting  
Midland Radio & Television Schools, Inc.

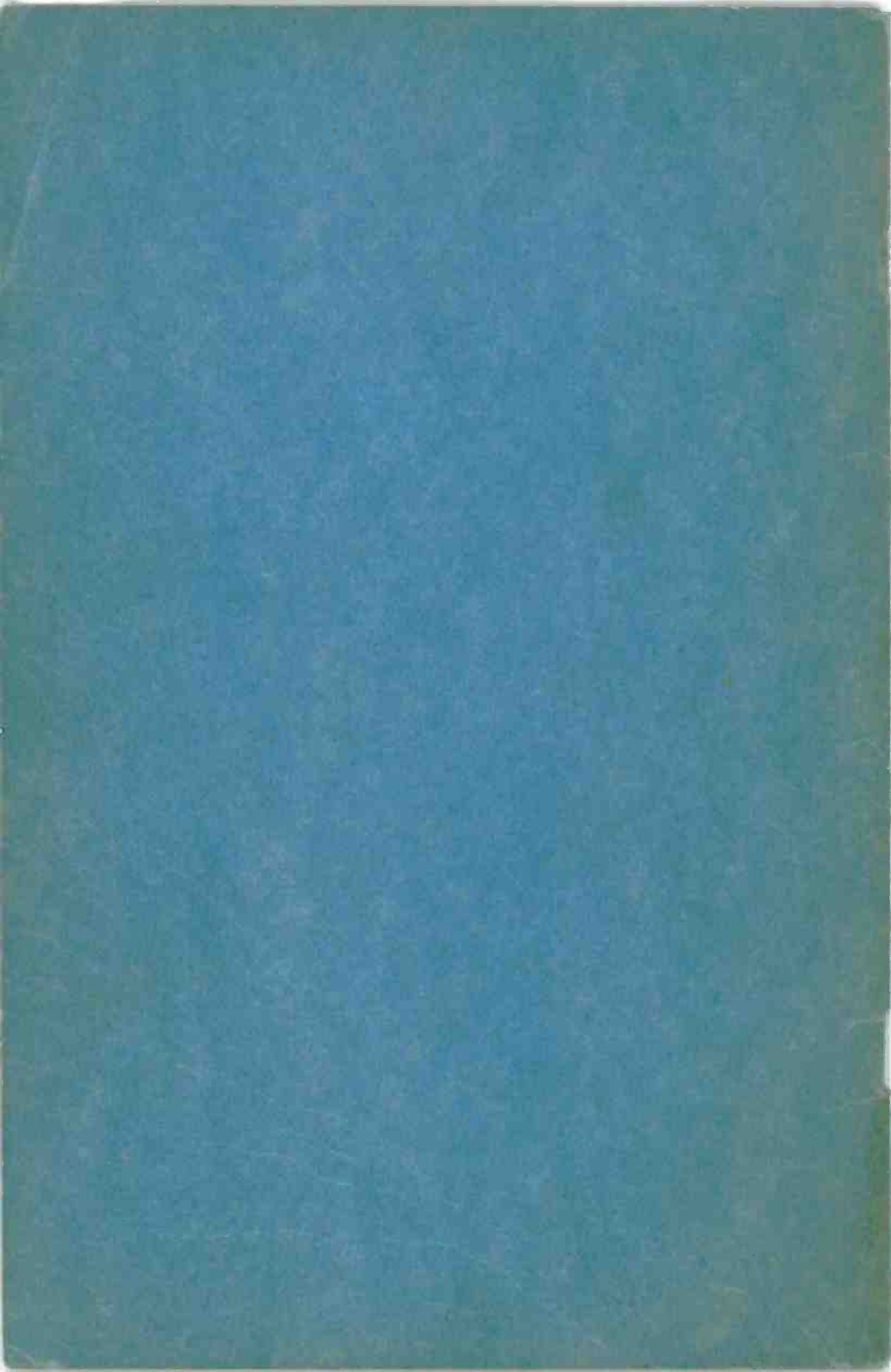



**MIDLAND RADIO  
AND TELEVISION  
SCHOOLS  
INC.**

**POWER & LIGHT BUILDING, KANSAS CITY, MISSOURI**

**UNIT  
NO.  
2**

**RECEIVER  
CIRCUIT  
ANALYSIS**

**LESSON  
NO.  
3**



# MR. BOGEY MAN

....."take my advice", says he.

Mr. Bogey Man. You know him, and I know him..... the well-meaning chap in shabby clothes that seems to think his duty in life is to discourage those that seek success. He is full of ideas as to how the Government should be run; knows exactly what you should do to make a million; but for some reason, he can't seem to make any money for himself.

When he hears about you, or Jim, or John studying hard for a better job, he up and says with a laugh, "They're wastin' their time. I never did believe in studyin'." Poor Mr. Bogey Man. His mind is warped and his ambition is gone. He doesn't believe in education and preaches the gospel of "a feller's got to wait fer lady luck to come his way." And he will still be waiting when they carry him off to a pauper's grave.

When you encounter such individuals, you must guard yourself against them. If they laugh at your serious efforts, remember that "he who laughs last, laughs best." When you have capitalized on your training and are enjoying life, Mr. Bogey Man will still be wearing the same old clothes and claiming that you were lucky. Of course, in a way you are lucky, for you have the ambition that he lacks. **YOU ARE DETERMINED TO BE A SUCCESS!**

Today, as never before, you must be thoroughly trained if you expect employers to place you in a job of responsibility. And those are the jobs that offer the highest pay. The more you know and the harder you work, the more money you will earn.....money that will enable you to enjoy your leisure hours to best advantage. As time passes by and you gain valuable experience, you will progress toward an executive position .....your income will increase.....you will be able to afford a finer car, a more pretentious home, and travel to distant places of interest.....

.....yes, you will be able to enjoy life to its fullest extent, if you disregard the advice of Mr. Bogey Man, stick to your training and work toward a definite, advanced objective even after you are employed!

Copyright 1941

By

Midland Radio & Television  
Schools, Inc.

PRINTED IN U.S.A.



KANSAS CITY, MO.

# Lesson Three

## RECEIVER CIRCUIT ANALYSIS



"Applying your theoretical knowledge of radio circuits to the repair of commercial radio receivers is of utmost importance. The actual experience you gain while doing work of this kind is an undeniable asset.

"In this lesson, I am going to outline the two fundamental methods of analyzing radio receiver circuits; namely the "voltage-current measurement" and the "point-to-point resistance" methods. By doing this, I hope to enhance your ability to repair radio sets and thereby make it possible for you to make more "spare-time" money."

1. INTRODUCTION. In the first lessons of this Unit, the student has been given complete information on various instruments used in the servicing business. As stated in Lesson 2, it is not necessary that the serviceman have every one of these instruments to set himself up in a business of his own; however, the more instruments that he has available, the better and quicker he will be able to perform the necessary tests to determine the condition of a defective receiver.

Having studied these instruments, the student is now equipped to use them to the best advantage and to make a rapid interpretation of the results of the various tests he makes. In this lesson we shall make our first studies of various methods of testing defective radio receivers and shall determine which part, or parts, are defective and require replacement. One thing which we must emphasize at this time is the basic simplicity of radio servicing. This statement, to an average person who knew nothing of radio, would appear absurd. However, with the knowledge of the principles of the operation of a radio receiver firmly set in your mind, you will find that radio receiver servicing involves only the application of this knowledge in a "common sense" manner.

In this lesson the student will study two methods of servicing a radio receiver. These two methods are known generally as the "Voltage and Current" analysis and the "Point-to-Point" resistance methods. It is not our purpose in presenting these two

methods to give the impression that they are either the best or the only methods of making tests. On the contrary, we feel that the student should be acquainted with every method and thus he will be able to choose that method which best suits the equipment he has available as well as the particular problem he has to solve in servicing a radio receiver. As a matter of fact, the serviceman will probably end up by using a combination of several methods. We believe that these two methods of servicing are the simplest and the easiest to learn, and for that reason are presenting them at this time.

Before proceeding with the actual description of the tests to be made in the "Voltage and Current" analysis of radio receivers, let us consider the preliminary circumstances leading up to the actual servicing of a radio receiver.

In most cases, the source of a service "job" is a call from a customer indicating trouble with the receiver. If this trouble can be repaired easily, it is always to your advantage to make those repairs "on the job"; that is, the customer's home. In most cases, radio repair jobs are charged on a "time and material" basis. So, to save time and expense for both yourself and the customer, all jobs should be completed in the customer's home if possible. To speed up the preliminary tests and thus assist the serviceman in his work, manufacturers and servicemen's organizations have devoted a great deal of time and effort in developing instruments along these lines. It is the job of the serviceman to use the best methods to determine the trouble quickly, and then to make the most direct and rapid repair possible.

Equipment carried to a customer's home need not comprise a complete service shop. On the contrary, the minimum amount of equipment should be carried into a customer's home. The following list of instruments and tools may be used as a guide for the serviceman in making up his "portable" equipment. As you gain experience you will be able to add to this list or to omit items as required.

(A) INSTRUMENTS:

- (1) Ohmmeter
- (2) Analyzer
- (3) Tube Tester

It is possible that all three of these instruments may be combined in a single tester. On the other hand, the serviceman may own a Universal Meter which can be used easily in place of the Analyzer. More time will be taken in this case than when using the Analyzer, but results will be the same. A tube tester is not essential, but desirable. Tubes can be tested by the replacement method, but this requires the carrying of quite a large selection of tubes, which is generally unsatisfactory.

Tools:

- 1 Pair long nose or needle point pliers
- 1 Pair gas pliers
- 1 Pair diagonal cutting pliers



- 1 Set Spin Tite socket wrenches (optional)
- 3 Screwdrivers; 2", 4", and 6" blades
- 1 Set aligning tools (Any commercial set comprising insulated screwdrivers, wrenches, tuning wand, etc.)

These tools will be discussed at greater length in the lesson devoted to the alignment of radio receivers.

- 1 Soldering iron, medium size
- 1 Small one-inch varnish brush

*(B) REPLACEMENT PARTS:*

A set of various resistors, capacitors, and tubes of various sizes and types must be available to make rapid repairs. Only experience will show how many and what sizes to carry.

When you receive a call to a customer's home, it is usually because his set is not operating as it should or is not operating at all. The average person ordinarily will not call a serviceman for only a slight defect such as poor quality or poor reception. They feel that the set can still be heard and understood, so why spend money to repair it. As a result, the serviceman is not called until the set is either completely inoperative or the quality and reception is so poor that the program cannot be understood.

Upon arriving at the customer's home, certain information must be obtained from the owner of the receiver to be used as a basis for tests. By this we do not, under any circumstances, wish the service engineer to ask the question "What is the trouble with your receiver"? If the customer knew the answer to this question, he would probably not have called you. Do not ask too many questions. The attitude of the customer will give you an indication of how far to go in your questioning of him. If the customer is willing to answer your questions, his answers will give you an indication of the source of trouble even before you begin your tests. It also saves you time in finding the trouble and makes your repair a great deal quicker than if you had to start from scratch.

Before looking into these basic questions, let us consider another subject not related directly to receiver servicing, but equally important to your success as a service engineer. You have heard the expression "first impressions are lasting". This expression is especially true in the business world, and it behooves every service engineer to watch his appearance. This is most important, as many times a poor appearance will cause loss of future jobs with that customer. This does not mean that you should wear expensive clothes. However, your clothes should be clean and neatly pressed. A customer looks on greasy and dirty clothing as a danger to his household furnishings. A shoe shine, hair cut and shave will improve your appearance 100% and these points should be watched closely. Clean hands always give a customer a pleasant impression that he can trust you with his "beautiful radio cover". This subject of neatness can also include your

equipment. By keeping all your tools in place in your tool kit, you not only give the customer an impression of neatness, but you save yourself time in always knowing where to reach for any tool, thus saving yourself a time-consuming search for "lost" tools.

When talking to the customer and questioning him as to the operation of the set, never adopt an arrogant manner. A "know-it-all" attitude will antagonize a customer quicker than any other factor. You must also be patient with the customer. Many times he will ask questions which seem ridiculous to you, but remember, you know the "intricacies" of a radio receiver, while he knows nothing on this particular subject. So the answer to all questions should be given courteously to the full extent of your knowledge. Finally, in answering the customer's questions, never falter or hesitate as though you were uncertain. This would give the customer an impression of ignorance on your part and he would hesitate in calling you for any further service work he may have. On the other hand, under no circumstances need you resort to a false statement. The customer will eventually learn the truth and you will have lost a customer.

We are listing below several questions which may be asked upon reaching a customer's home. These questions need not be memorized, nor need the exact wording be used. These questions are given you as a guide to follow when making your call upon a customer.

1. What is your complaint about your receiver?
2. Did the trouble develop recently?
3. Did the trouble occur suddenly or did it come on gradually?
4. Has this trouble been experienced before this time?
5. If the trouble has occurred before, was it repaired at that time?

It is possible that the complaint will be "fading" or "intermittent reception", in which case the following questions might be in order.

1. Does reception die out gradually or is it cut off sharply?
2. Does reception return to normal, and how long a time elapses before it returns?
3. Can the set be made operative again by some unusual act, such as snapping a switch or rapping the cabinet?
4. If the complaint is "fading", how often does the fading occur and does it return to normal gradually or with a sharp click?
5. Does fading occur on all settings of the dial or only on one or two stations?

If the complaint is "noisy reception", the following questions should be asked.

1. How long has the noisy condition existed?
2. Is the noise of an intermittent or continuous nature?

3. Is the noise present at all times of the day and evening, or only at certain intervals?

Unless some condition prevents your doing so, the service engineer should turn the AC switch of the defective receiver to the "On" position. Of course, if you know from the customer's answers to your questions that a power supply is shorted or a power transformer is burned out, this should not be done. While the heaters of the tubes are warming up, you can question the customer more fully. If the owner of the receiver can state definitely his complaint, it is an indication that there is some actual defect in the receiver. As you gain experience, you will find that many times a customer will call you only because he "thinks" there is something wrong with his receiver. In cases of this kind your judgment and experience will guide you in further questioning.

If, while questioning the customer, you learn that the trouble has occurred only recently, it is an indication that the trouble is not an inherent fault of the receiver. However, if the same trouble occurred previously, it is important to learn whether or not the receiver operated satisfactorily after being repaired. It is possible that the set was either not repaired at all; or only temporary, or ineffective repairs were made. In either case, your questioning of the customer will reveal what steps should be taken.

The course to be followed by the service engineer from this point on, depends entirely upon the symptoms. A clue to the trouble is often found by noting carefully the symptoms exhibited by the receiver when turned on. You will find that in most cases the symptoms will fall under one of the following classifications.

1. The receiver may be inoperative or "dead"; that is, no signal will be heard when the receiver is turned on.
2. The output may be "noisy", "scratchy", or weak; that is, the signal is heard but is accompanied by noise of one nature or another. Or the signal may be clear but so weak that even with full volume of the receiver it is noticeably low in strength.
3. The signal may be heard only intermittently.
4. The signal may be at full strength, and also be entirely free from noise, but its quality may be poor. It is possible that some defective part will cause only low frequencies or only high frequencies to be amplified, in which case, the response of the receiver will sound either "boomy" due to the excess of low frequencies, or will sound "shrill" due to the excess of high frequencies.
5. The signal may be accompanied by a distinct "rattle" on certain notes or frequencies. This is usually the case on strong signals or high volume from the loud speaker. In most cases this trouble can be traced directly to a defective loud speaker.
6. The receiver may have a high hum level or may "oscillate". The latter condition is distinguished by a

constant frequency note, usually high pitched. It may or may not be changed in frequency by varying the main station selector control.

7. The set may operate normally, but when the volume control, the station selector, or the tone control is rotated, such movement is accompanied by scratches or noises in the receiver output.

2. **PRELIMINARY CHECKS.** Having found certain definite symptoms in the receiver under test, the service engineer must reason out carefully just what defects might cause the symptom found. Experience is the best teacher in this respect, as many times, sets of the same type and manufacture act in much the same manner. An experienced service engineer will have worked out a system which will isolate the defect in the quickest way. For the inexperienced man, we suggest the following method as a basis of starting your own system.

There are several preliminary tests which can be made which will localize quickly the source of trouble in a defective receiver without removing the receiver chassis from the cabinet or without using any metering equipment. Let us consider first the general types of radio receivers. The most popular type at the present time is the Superheterodyne, but there are still a few Tuned Radio Frequency receivers on the market. Naturally, receivers made by the different manufacturers will vary as to the tubes and the circuits, parts and layout; but they can generally all be classified under either of the two general classes of Superheterodynes or Tuned Radio Frequency receivers. From your studies in Unit 1, you will remember that actually, all receivers consist of several separate electrical units, each of which is designed to perform a separate function. These units are all combined on a single chassis, and interwired; however, for the purpose of study, we can conveniently consider each unit separately.

In a Tuned Radio Frequency, or TRF receiver as we shall call it hereafter, the essential components are the Tuner and R.F. Amplifier, the Detector, the Audio Frequency Amplifier, the Loudspeaker and the Power Supply. The Tuner and R.F. Amplifier act as a selector of the signal as well as an amplifier. The detector acts as a demodulator of the carrier wave; in other words, it separates the audio portion from the R.F. portion of the incoming signal. The A.F. amplifier increases the power of the weak A.F. signals received from the detector. The loudspeaker converts the A.F. electrical signal into audible signals, and the power supply furnishes the necessary heater, plate, and grid voltages for operating the tubes used in the various circuits.

In a superheterodyne receiver, the audio amplifier, loudspeaker and power supply units are the same as in the TRF; however, the method of signal voltage amplification up to the second detector, differs greatly from that employed in the TRF type. In most Superheterodynes, the radio signal induced in the antenna is fed directly to an R.F. amplifier. From there it pass-

es to the first detector or mixer tube, and by combining with the steady R.F. output of the local oscillator, the carrier frequency is reduced to that of the I.F. amplifier. The signal is then fed through the I.F. amplifier for further amplification and on to the second detector where the audio component is removed from the modulated I.F. wave. Following the second detector, the audio amplification and reproduction from the loudspeaker occur the same as in a TRF receiver.

The essential difference between the operation of TRF and superheterodyne types of circuits lies in the fact that a superheterodyne employs a local oscillator which beats against the incoming signal and reduces its frequency to that of the I.F. amplifier. The majority of signal amplification is then secured at the fixed frequency to which the I.F. is tuned. In many receivers, the functions of the local oscillator and the mixer are performed simultaneously by a single pentagrid converter tube.

Now that we have sectionalized both TRF and Superheterodyne Receivers, and have the functions of these various sections well in mind, let us talk about some simple tests which will enable the Service Engineer to isolate that section of the receiver in which the trouble exists. In the following tests we are assuming that the set you are testing is "dead".

When the detector tube is tapped sharply with the finger and a ringing sound, or "bong", is heard from the loudspeaker, it immediately indicates to the service engineer that the A.F. amplifier, the loudspeaker and the power supply units of the set are operating satisfactorily. If this simple test indicates that these units are operating correctly, then the service engineer should immediately pass on to the next test. However, if no "bong" is produced, attention should be directed to the individual analysis and test of each of these parts.

A second test on the detector consists of placing either the finger or the aerial lead-in on the grid terminal of the detector tube while it is in its socket. A loud hum will be heard from the speaker if the detector, A.F. amplifier, loudspeaker and power supply unit are in good condition. This is an especially convenient test if the detector is a screen grid tube, since the control grid cap on the top of the tube is readily accessible. This test should be executed with the grid connecting clip removed.

Assuming that the aforementioned tests have failed to indicate the trouble, then the R.F. or I.F. section of the receiver is at fault, or else the detector is of the diode type, in which case the hum response test is not effective.

If the above tests are applied to a TRF receiver and indicate that the detector and parts following it are in good operating condition, then the next step is to locate the portion of the R.F. amplifier wherein the trouble lies. A simple procedure for localizing the trouble consists of first removing the last R.F. amplifier tube from its socket and placing the free end of the antenna

lead-in wire onto the plate contact spring. (It might be well to connect a small condenser in series to block the DC and thus prevent shorting of the supply.) With the lead-in connected and the receiver dial tuned to a strong local station, a weak signal should be heard from the loudspeaker if this R.F. stage is operating satisfactorily. If the last R.F. stage is operating, the tube should be replaced, then the tube from the R.F. stage immediately preceding should be removed and the lead-in wire placed on the plate contact spring of that socket. If this stage is working satisfactorily, a signal should be heard from the loudspeaker when the dial is tuned to a strong local station, and, of course, it should be louder than when the lead-in wire was placed on the plate contact spring of the last R.F. amplifier. Following this same procedure back to the antenna should provide localization of the trouble in the R.F. amplifier.

This R.F. amplifier stage-by-stage test cannot be applied satisfactorily to a superheterodyne receiver because the I.F. amplifier is tuned to a frequency lower than that of a broadcast station. A quick test can be performed on a superheterodyne, however, by tapping or touching the control grid of the I.F., first detector and R.F. tubes with the free end of the lead-in wire. Whereas, no signal reception is expected, a loud click should be heard when the lead-in wire makes contact. The intensity of the click should increase as the lead-in wire is moved from stage to stage, back toward the antenna. If the volume control of the receiver is located in the diode detector circuit, it will be necessary to have it fully advanced in order to conduct the test. Misalignment of the various tuned circuits will not show up in a test of this kind.

Some experienced service engineers choose to adopt still another method of isolating radio receiver faults quickly. This method consists of quickly removing and reinserting each tube in the set and noting the intensity of the clicks produced in the loudspeaker. This test should start with the last tube in the A.F. amplifier. If no click is heard upon removing this tube, it is almost certain that the loudspeaker, power supply, or last A.F. circuit is defective. Those parts of the receiver should be completely tested at once.

Pulling the tubes in a receiver out of their sockets is not exceptionally good practice because of the current surges created at the instant of removal. Sometimes these surges may be sufficient to cause a breakdown of the windings in an audio transformer. Also, if the power tube or tubes are removed while the set is operating, it may damage or puncture the electrolytic filter condensers in the power supply because of the increased voltage placed across them, due to the instantaneous reduction in load current.

It is possible that these preliminary checks show no apparent trouble in the receiver, in which case the antenna system should be checked. By the antenna system we mean the entire antenna circuit consisting of antenna, lead-in, lightning arrestor (when used), ground lead, and ground connection.

The simplest method of checking the antenna system is to disconnect the lead-in and the ground from the radio receiver and measure the resistance between these two leads, as shown in Fig. 1. If the circuit is open; that is, if there is no reading on the ohmmeter, the antenna circuit is OK and need not be checked further. However, if the ohmmeter shows a reading either of medium or low resistance, it indicates a leakage path or a direct short somewhere in the antenna system and further checks will be necessary.

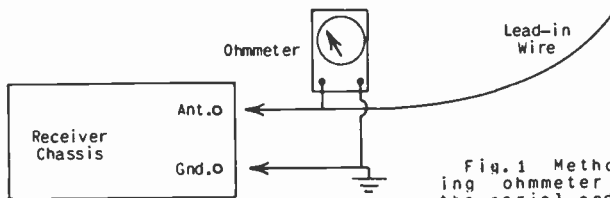

Fig. 1 Method of connecting ohmmeter for testing the aerial and lead-in for a short circuit.

Lightning arrestors are often a source of such trouble and the next check should be at this point. To make this check, the lead-in wire between the lightning arrestor and the receiver should be disconnected and the resistance across the lightning arrestor measured with an ohmmeter as shown in Fig. 2. If a low

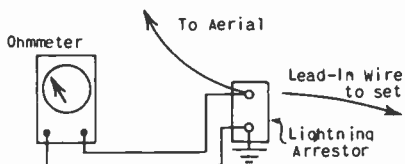

Fig. 2 Connecting ohmmeter across lightning arrestor to test for short.

resistance is found across the lightning arrestor, it is an indication of a shorted or leaking unit and it must be repaired or replaced. Some arrestors cannot be repaired and the service engineer must use his own judgment as to what course to follow. If the resistance across the lightning arrestor is high, it is an indication that the unit is OK and we must look elsewhere for the trouble. Often, you will find that the measurement of the antenna circuit at the receiver will indicate a short, while the lightning arrestor will be found to be OK. In this case, it is quite evident that the short or leakage path occurs somewhere between the lightning arrestor and the receiver under test. Such a condition is often caused by the antenna and ground wires shorting together where they enter the house, or perhaps the antenna wire is shorted to a metal object such as a radiator. Many times, where the lead-in and ground wires are tacked down, the head of the tack may be shorting the wires together.

The final test to make in the antenna system is a check on the efficiency of the ground connection. A high resistance ground

connection often is a cause of weak reception, while an intermittent ground will result in a noisy condition in the receiver under test. A simple test of the ground connection is shown in Fig. 3. The first step in this check is to measure the line voltage at the outlet to which the receiver is usually connected. Next, measure the AC voltage from the outlet to the ground lead at the set. It is wise to disconnect this ground lead from the receiver for this test. If a reading is not obtained at first, the test lead at the AC outlet should be changed to the other side of the outlet. Fig. 3 shows these connections. One side of the AC line

Fig. 3 Testing the efficiency of the ground system with an AC voltmeter

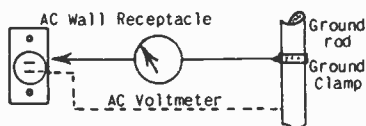

is grounded as shown by the dotted line. If the ground connection is good, the voltage under these conditions should read at least 90% of the line voltage as read at the outlet. That is, if the line voltage is 110 volts, the reading obtained through the ground connection should not be less than 99 volts.

The preliminary tests mentioned in the preceding paragraphs have been more or less applied to "dead" or "weak" receivers. In the case of noisy sets, or those in which there is an indication of oscillation, only one of the above methods proves satisfactory. That is, the removing of the tubes in consecutive order until the noise or oscillating condition disappears. That circuit is then the source of the trouble. This method cannot be applied to DC receivers, as in that type of set the filaments are usually in series, and removing one tube breaks the filament circuit for the remainder of the tubes.

In those sets in which the complaint is either poor quality or intermittent reception, more exact tests must be made to isolate the defect to a particular section of the receiver. These methods will be explained in detail later in this lesson.

It has taken quite some time to explain these various preliminary tests, but actually they take only a few moments to perform. The experienced service engineer becomes so proficient that he performs these tests automatically. It is always wise to make these tests because the majority of troubles can be localized during such procedure. Although these tests do not give you the exact cause of the trouble, it saves you a great deal of time in localizing the trouble to a comparatively small section of the receiver. When you are making tests or repairs in a customer's home, time is an important element. The quicker you can locate and repair the trouble, the better impression you will make on the customer. If the preliminary tests have not been made, it would be necessary to make a complete analysis of the receiver stage-by-stage either by the "Voltage and Current" method or by the "Point-to-Point" resistance method. Such an analysis is often a good



thing, but it takes quite a length of time. Of course, it is possible that the preliminary tests have given you no indication as to the source of trouble, in which case it is necessary to make the stage-by-stage analysis.

We would like to point out more strongly that these preliminary tests are not capable of isolating trouble to any particular point. It is possible that they can all be carried through and still not give any indication as to the source of trouble in the receiver under test. The value of these tests lies entirely in the fact that they enable the service engineer to limit the number of tests he must make to a certain section of the receiver.

Fig.4 TUBE SOCKET VOLTAGES R.C.A. 140  
120 Volt A.C. Line

RADIOTRON NO.	CONTROL GRID TO CATHODE VOLTS	SCREEN GRID TO CATHODE VOLTS	PLATE TO CATHODE VOLTS	PLATE CURRENT M. A.	FILAMENT OR HEATER VOLTS
RCA-58, R. F.	**2.0	100	255	6.0	2.6
RCA-58, S. W. R. F.	**2.0	100	255	6.0	2.6
RCA-2A7, Det. - Osc.	**2.5	100	250	5.0	2.6
RCA-58, I. F.	**2.0	100	255	6.0	2.6
RCA-2B7, 2nd Det. - AVC	**1.5	35	105	1.5	2.6
RCA-56, A. F. Driver	**12.0		245	6.0	2.6
RCA-53, Output	0		300	36.0	2.6
RCA-80, Rectifier	640 R.M.S. Plate to Plate			130 per Plate	

\* Voltages and current apply to detector portion of tube.

\*\* These voltages cannot be measured because of the high resistance of the circuits.

The next step in the testing routine is the checking of tubes. If our preliminary tests have not shown any particular section to be defective, it will be necessary to test all tubes, and replace all those which are weak or defective. If our preliminary tests have shown some particular circuit to be at fault, it is only necessary to test those tubes in that section.

3. VOLTAGE-CURRENT ANALYSIS. One method of making a complete analysis of the circuits of the receiver would be for the service engineer to remove the chassis from the cabinet, to isolate each component part and measure it with an ohmmeter or continuity meter until the defective part is found. This method would undoubtedly locate the defective part, but the modern receiver is so complex that a great deal of time would be consumed in isolating and checking each individual part. The test equipment now available makes this time-consuming method of servicing unnecessary. Two general methods of analysis may be followed. One, the "Voltage-Current" method, will be discussed in the following pages. The other, the "Point-to-Point" resistance method, will be discussed later in this lesson.

In nearly all receivers, the main circuits are associated with the tube socket terminals. If any trouble exists in any of

these circuits, it will, as a rule, affect either the voltage at one of the socket terminals or will affect the current flowing through one of the terminals to the tube itself. This theory is the basis of all "Voltage-Current" methods. It will be found that in most cases a Voltage-Current analysis can be made without removing the chassis from the cabinet.

Using this method, a complete receiver may be analyzed by carefully measuring the voltage at each terminal of each socket in the receiver and by measuring the current in some of the circuits. The voltage and current readings are then compared with the information furnished by the manufacturer for the particular make and model of the receiver under test. This information may be furnished to you in several forms. Fig. 4 shows a tabular form of tube socket voltages. In later models, due to the complex nature of tubes, manufacturers have adopted the method shown in Fig. 5. In this method you will note that the voltage reading for each terminal is given at that point. Current readings are given in a small appended table.

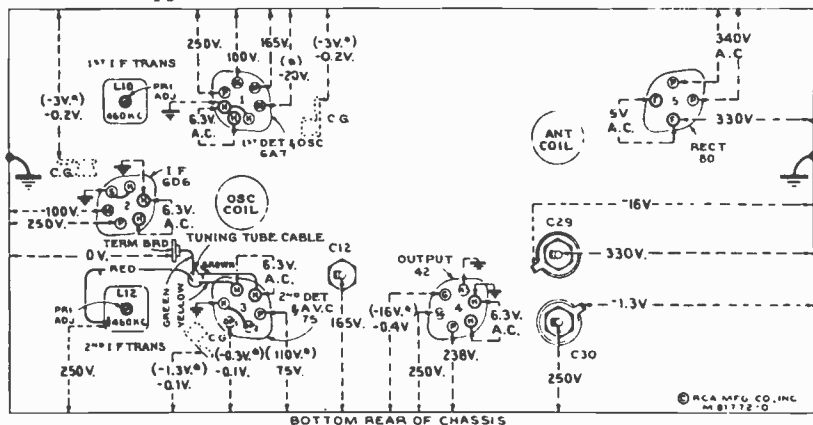

Fig. 5 Another method of indicating socket voltages of a receiver.

By comparing the voltages and currents measured on the receiver under test with the information furnished in the manufacturer's service notes, the possible cause of the defective operation will no doubt be made clear. Any voltage or current measurement which differs greatly from the manufacturer's measurements is an indication of trouble in the circuit which supplies that particular element of the tube.

Using the "Voltage-Current" method of receiver analysis, servicing may then be carried out in three main steps. These are:

1. Complete voltage and current measurement at all tube socket terminals, and as a result, a localization of the trouble to a single section of the receiver.
2. Isolation of the defective part in that circuit through the use of the necessary instruments to test each component part.

3. Making the necessary repairs or replacements to correct the trouble found.

To illustrate this method of analysis, let us use the simple circuit shown in Fig. 6. The general system used in analyzing this circuit may be used in every circuit of the receiver. It must be kept in mind, however, that each and every circuit must be checked if an accurate indication of the condition of the receiver is required. In this discussion we shall consider the measurements as being made with individual meters. We are doing this to acquaint you with exactly where measurements are being taken, and also to show you how these measurements may be made when an analyzer is not available. The speed with which an analyzer makes these measurements is of such an advantage that it is usually the first piece of equipment purchased by the service engineer.

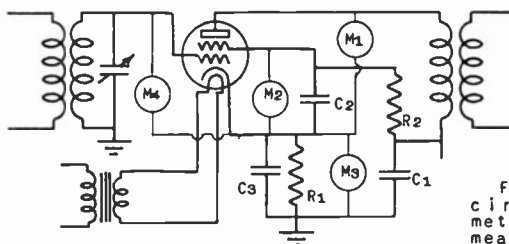

Fig. 6 Screen grid tube circuit with individual meters inserted for voltage measurements.

As we are assuming that the bright glow of the heater in the tube can be seen, we will omit the AC voltmeter in the filament circuit. If the tube is made of metal, the temperature of the outer metallic shell rises sufficiently to indicate that the filament circuit is complete. A low range DC voltmeter is necessary to measure the grid bias voltage, and a high range DC voltmeter is necessary to measure the plate and screen grid voltages. All these instruments must be of the high resistance type so as to have as little effect as possible on the circuits being measured. In addition, a milliammeter will be necessary if any current measurements are to be made.

When measuring the voltages on this tube, the cathode is used as a common point. The reason for this is that it is common practice for tube and set manufacturers to rate their tube voltages with the electron emitting element as a common point. In this case, the cathode is the electron emitting element, and so it is used as the common point. If a directly heated electron emitting element is used, for example, a filament type tube, measurements are made with the mid-tap of the filament supply as a common point of measurement. If a DC supply is used, all measurements are made with the negative side of the filament supply as the common point.

To measure the plate voltage, the meter is connected between the plate and cathode terminals of the socket. This is indicated by  $M_1$  in Fig. 6. After measuring the plate voltage, the screen

grid voltage should be measured next. This is done by connecting the meter between the screen grid and the cathode terminals as indicated by the meter  $M_2$  in Fig. 6. The next measurement is of the grid bias voltage. A low range meter should be used. The grid bias voltage may be measured in two places, or rather by two methods. If the grid return circuit is grounded, the voltage between cathode and ground should give the bias voltage. This is shown by  $M_3$  in Fig. 6. However, this method gives no indication of the condition of the transformer secondary, and even though a reading is obtained between cathode and ground, it is possible that no bias voltage reaches the grid, due to an open transformer secondary. It is therefore better to measure the voltage directly between the control grid and the cathode as shown by  $M_4$  in Fig. 6.

If it is found necessary to make current measurements, it will be necessary to unsolder the wires connected to the socket terminals and insert a milliammeter in the circuit. This method is obviously a rather lengthy process. It requires the removal of the chassis from the cabinet, etc., which is rather a difficult thing to do in a customer's home. It is possible to get an approximate indication of the current in the plate and screen circuits with only voltage measurements. If the screen voltage is lower than the plate voltage, it is obvious that screen current is flowing. This current can be calculated by subtracting the screen voltage from the plate voltage and dividing by resistance  $R_2$ . Also, by measuring the voltage between the cathode and ground and dividing by the series cathode resistor  $R_1$ , the cathode current can be calculated. As both plate current and screen current pass through the cathode circuit, it follows that the calculated cathode current minus the calculated screen current will give the value of plate current.

We will not take space at this time to discuss circuit defects which may affect the voltage readings. In the following paragraphs, wherein the method of "Voltage-Current" analysis using the commercial set analyzer is discussed, detailed information will be given on this point.

4. THE VOLTAGE-CURRENT ANALYZER. In Lesson 1, you studied the so-called "Free-Point" Analyzer in detail. To refresh your memory, however, let us briefly describe this type of analyzer again.

The free-point analyzer, in effect, brings out the circuits of the tube being checked to a point where they can be conveniently tested. By its inherent design, it allows the measurement of voltages between any two elements of the tube and the measurement of the current flowing through any single element. As you learned in Lesson 1 how measurements were made with this instrument, we shall proceed at once with the analysis of a receiver circuit.

In Fig. 7, we show a comparatively simple circuit diagram of a 5-tube superheterodyne receiver. We have purposely omitted any AVC, AFC, or similar circuits to keep our discussion from becoming too involved. These circuits will be discussed in detail in a

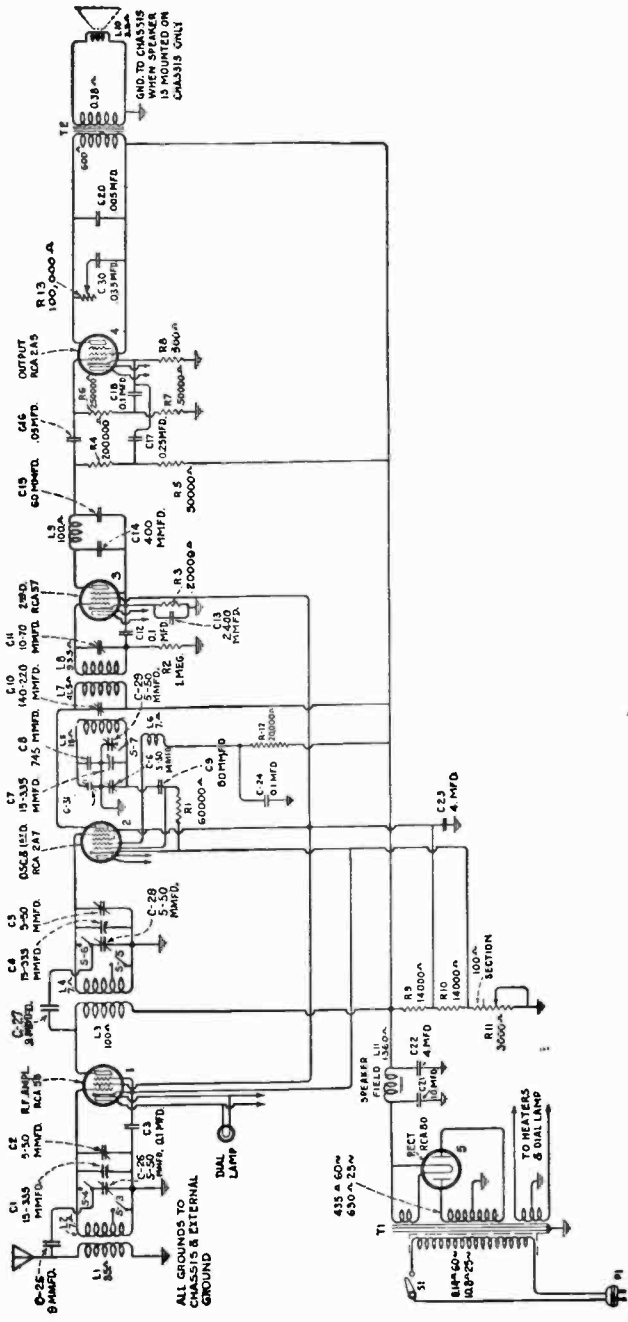

Fig. 7 Diagram of a simple superheterodyne receiver used to explain the operation of an analyzer.

later lesson. Assuming that our preliminary tests have not indicated which circuit is at fault in the receiver, it will be necessary to make a complete analysis of all stages in order to locate the defective circuits and parts. Of course, if our preliminary tests have shown us that one certain circuit is defective, it is only necessary to analyze the tube or tube circuits affected.

Our first test will be on the output tube, a 2A5. As this is a 6-prong tube, the analyzer cable is fitted with the 6-prong adapter, and the plug and adapter placed in the output socket after the tube has been removed. The 2A5 is placed in the 6-prong socket in the analyzer and we are ready to proceed with our tests.

RADIOTRON SOCKET VOLTAGES					
115 Volt AC Line					
MAXIMUM VOLUME CONTROL SETTING - NO SETTING					
RADIOTRON NO.	CATHODE TO CONTROL GRID VOLTS	CATHODE TO SCREEN GRID VOLTS	CATHODE TO PLATE, VOLTS	PLATE CURRENT, MA.	HEATER VOLTS
1. RCA-58 R.F. Amp.	3.0	95	250	5.0	2.33
2. RCA-2A7 1st Det. Osc.	3.0	95	250	3.0	2.33
3. RCA-57 2nd Det.	6.0	89	170	0.3	2.33
4. RCA-2A5 Power Amp.	18.0	235	220	32.0	2.33
5. RCA-80 Rectifier	275 volts PLATE TO PLATE - 60 MA. TOTAL				4.82
TOTAL CATHODE CURRENT - 11 MA.					

Fig. 8 Socket voltages of the receiver illustrated in Fig. 7.

Our first measurement is of the plate voltage as measured between plate and cathode. Looking at the voltage chart shown in Fig. 8, we see that this voltage should be approximately 220 volts. A variation of from 8% to 10% in this and all voltage readings is considered as within reason, and in this case, any voltage between 200 and 240 volts would be taken as being satisfactory. Now, suppose that we found no voltage was available at the plate prong. This could be caused by an open primary in the output transformer, a defective power supply, or an open lead from the power supply filter system. Looking at the schematic, we see that the screen grid of the 2A5 output tube has a common voltage supply with the plate. It is logical then to measure the voltage between the cathode and screen grid. If this voltage is found to be normal, (235 volts as shown on the chart in Fig. 8) and the plate voltage is zero, we can be sure that the output transformer primary is open. Now, let us assume that the screen voltage and plate voltage are equal. This condition should not exist, so we examine the schematic to find what would cause such a defect. First, if the output transformer primary were shorted, there would be no voltage drop, and the plate and screen voltages would be equal. The same condition would also exist if the equalizing capacitor were shorted, or the capacitor in series with the variable resistance were shorted. The latter condition, however, would be indicated by a change in the difference between the screen voltage and plate voltage when the tone control is rotated. If the screen voltage and plate voltage are found to be zero, it is an indica-

tion that the power supply is defective and we should immediately check that unit.

Assuming that the screen and plate voltages have been found satisfactory, we next measure the voltage between the control grid and the cathode. Again referring to the voltage table, we find that this voltage should be approximately 18 volts. It is possible that this voltage could be as high as 150 to 170 volts, in which case, we would immediately check for a shorted coupling capacitor ( $C_{1s}$  in Fig. 7), as such a defect would allow the application of the plate voltage on the second detector to the grid of the output tube. However, a no-voltage indication between grid and cathode would be caused by an open circuit in resistor  $R_6$ ,  $R_7$ , or  $R_8$ , or by a short in capacitor  $C_{1s}$ . A shorted resistor  $R_6$  would also cause such a defect. If  $R_8$  were open, we would find that the voltages at the plate and screen would be practically equal inasmuch as no plate current is flowing to cause a voltage drop across the primary of the output transformer. If  $R_8$  were shorted or the grid resistors  $R_6$  and  $R_7$  were open, the plate current would rise to a high value, due to the fact that there would be no bias voltage on the grid of the tube. Our next test, then, is the measurement of the current in the plate circuit.

Having completed our tests on the output stage and assuming that our voltage measurements indicate that no defect exists in the circuits connected with that stage, we are now ready to analyze the detector stage. Examining the circuit diagram, we find that this stage employs a type 57 tube. This tube also uses a 6-prong base, so no change in the analyzer cable adapter need be made. Having removed the analyzer cable from the output socket, and replacing the 2A5 output tube in its socket, we now remove the type 57 second detector, put the analyzer plug in that socket, and place the tube in the 6-prong socket on the analyzer panel.

As before, our first measurement is made on the plate voltage. In this case, we find from the voltage table that the voltage between plate and cathode should be approximately 170 volts. Let us assume that after measuring this voltage and comparing it with the voltage table in Fig. 7, we find the voltage high; let us say it is somewhat over 200 volts. Studying the schematic diagram in Fig. 8, we find that the plate voltage is supplied through 2 resistors in series;  $R_4$  and  $R_5$ . If either of these were shorted, it would give us a high plate voltage. However, if no plate voltage was found on the plate of this tube, it would be an indication of an open circuit in either  $R_4$ ,  $R_5$ , or  $L_2$ , the R.F. choke. If the R.F. filter capacitor should become shorted, the plate voltage from plate to cathode would also be zero.

Examining the circuit diagram, we see that the #3 grid is connected to the cathode directly, so it is not necessary to make a voltage measurement on that element. Our next check, therefore, is a voltage measurement on the screen grid (grid #2). High or low voltage readings on this element are directly due to trouble in the power pack. Shorted or open bleeder resistors or a shorted filter capacitor  $C_{2s}$  will show up in incorrect screen grid volt-

ages. Moving on to our next voltage measurement, it is necessary to measure the voltage between control grid and cathode. In this case, the measurement should be approximately 6 volts. A no-voltage indication at the grid would be due to an open I.F. transformer secondary, an open grid resistor  $R_2$ , or an open bias resistor  $R_3$ .

We do not feel that it is necessary to describe further the voltage measurements on the oscillator-mixer tube or the R.F. amplifier tube. The method of measuring the voltages and currents on these tubes is identical with the method used for the second detector and output stages. Having completed the studies in Unit 1 of this course, the student need only consult the circuit diagram to determine just what defective parts could cause a low or high voltage or current reading.

Before proceeding with further discussion, one fact should be particularly noted. A voltage or current measurement should be carefully studied, and if possible, check measurements should be made before any decision is made as to the cause of an incorrect reading. Let us explain this further by again referring to Fig. 7. In the output stage, let us assume that we have a no-voltage indication at the plate. Glancing at the schematic diagram, our first reaction would be that the output transformer primary was open. However, it is possible that the fault really is in the power supply system. If the latter condition is true, it can be checked by measuring the plate voltage on the second detector. If no voltage is present at this point, we can be certain that the trouble exists in the power supply. However, if we find the correct voltage applied to the plate of the second detector, then we know for sure that the trouble exists only in the output stage, and our further tests can be confined to that stage.

In the preceding paragraphs, we believe you will have noticed one outstanding fact which was evident in practically every measurement made. That is the fact that there are usually several defects, any one of which may cause the erroneous meter reading. Obviously then, further analysis must be made of the circuit at fault to find the actual defective unit. These additional tests are usually made with an ohmmeter or similar instrument.

5. POINT-TO-POINT RESISTANCE ANALYSIS. Analyzing a radio receiver by the voltage-current method is based on the fact that defects in the receiver circuit will appear as incorrect voltages or currents as measured at the tube sockets. For example, if the plate circuit of a tube is open, there will be no measured voltage or current in that circuit. An open grid circuit would at once become apparent when no grid voltage was measured and, likewise, an open cathode circuit would be evident due to the lack of grid bias, plate voltage, screen voltage, plate current, etc.

In case incorrect voltages are measured at certain prongs on a tube socket, it indicates that a partial short circuit, high resistance connection, or defective resistor probably exists in that circuit. Nearly always, the trouble can be localized by a



voltage-current analysis, but to continue to find definitely the actual source of trouble, generally requires other tests.

In modern receivers, the circuits are becoming quite complex, and with their involved series-parallel circuit networks, abnormally high or low current or voltage readings at the tube sockets may be frequently caused by any one of several defects which cannot easily be analyzed from the readings alone. This is particularly true of the multi-tube, all-wave receivers of late design. Such radio sets incorporate such intricate circuits as automatic volume control, automatic frequency control, automatic tone compensation, noise limiting circuits, etc., all of which deviate considerably from the older methods of circuit design. Prior to about 1934, most radio circuits were conventional and relatively simple. Recent progress has completely destroyed such simplicity, and, as a result, the voltage-current method of circuit analysis has experienced a corresponding decrease in popularity. Of course, we do not mean to state that it is no longer possible to employ such a system in repairing a radio receiver, but we do feel justified in making the statement that voltage and current readings, as obtained with an analyzer, are not nearly so helpful to the service engineer on a modern receiver as was the case several years ago.

In view of the rising difficulties encountered when attempting to properly interpret analyzer readings, the "resistance" method of testing has gradually increased in popularity among service engineers. The resistance method of analyzing a radio circuit is commonly known as the "point-to-point" method. Those service engineers who are followers of this method advocate that after a voltage-current analysis of the receiver has been conducted and has indicated some sort of defect, it is still necessary to locate the inoperative part by the resistance method. Since a resistance measurement is the final test, they claim that the more logical method of procedure is to make these resistance measurements as the primary test and thus eliminate the preliminary voltage-current analysis. Even so, it is virtually impossible for the resistance measurement method of circuit analysis to supersede entirely the voltage measurement method, because in nearly all cases, it is necessary to make certain at least that the supply voltage is correct. In case the supply voltage is high or low, a radio receiver or amplifier will not function properly even though all resistance values throughout the entire circuit measure the correct value. In battery operated receivers, it is necessary that the A, B, and C batteries be in good condition. To determine whether or not this is true, it is necessary to make a few voltage measurements. In AC operated receivers, the line voltage and rectifier tube must be in good condition so as to supply the proper DC voltages to the plate and grid circuits of the tubes in the receiver. Thus, at least a line voltage measurement is necessary, and preferably a DC voltage measurement at the output of the power supply unit in addition to all of the resistance tests. Also, the tubes must be in good condition, so a tube check is essential in addition to the point-to-point circuit analysis.

An advantage of "point-to-point" analysis in comparison to "voltage measurement" is that a voltage measurement involves an entire circuit, so an incorrect voltage indicates that a defect might exist in any one of the units which comprise the entire circuit. Thus, the trouble is not definitely located, but merely localized to one portion of the receiver's circuit. With resistance measurements (combined with condenser testing), each individual unit in the circuit may be completely isolated and tested, irrespective of the others. Thus, when a defective part is found, the search is ended and the repair may be made quickly. The resistance method of testing also permits analysis of the circuit through the tube sockets and so may be done without removing the chassis from the cabinet.

To the newcomer in the field of radio servicing, resistance measurement or point-to-point analysis is extremely valuable, mainly because it reduces all types of receivers and circuits to a common servicing level. To locate the trouble in a radio set or amplifier, it is not absolutely necessary for the service engineer to be completely familiar with the theoretical operation of the circuits involved. Of course, a wiring diagram is very essential to properly conduct a resistance analysis of the receiver, and the diagram must have the resistance of each component plainly marked. Due to the increasing popularity of this method of servicing, receiver manufacturers have extended excellent cooperation, and at the present time, nearly all of them supply servicing data with the resistance values clearly marked on each unit.

Point-to-point analysis tends to stimulate a systematic procedure in repairing all types of radio sets and amplifiers. When one makes a resistance measurement between two points in a circuit, he may refer to the diagram and immediately know whether or not the resistance of the circuit is correct and so can progress to the next step. In contrast to this, when a voltage measurement is made, one is not so sure that the voltage is exactly right or wrong, unless he is perfectly familiar with the theoretical operation of the tube and circuit or has the manufacturer's voltage chart at hand.

To conduct a point-to-point resistance analysis it is necessary to use an ohmmeter that is capable of accurately measuring resistance values from one ohm to several megohms. This wide range is covered on commercial instruments with several ranges, generally three or four. The low range enables measurements from one ohm or less to about 500 ohms. One or two intermediate ranges then provide for measurements up to about 500,000 ohms. The highest range on the ohmmeter should then be capable of accurately measuring up to 30 or 40 megohms. The merit of point-to-point resistance analysis lies largely in the accuracy of the readings obtained, so the proper range should be selected and the meter read as closely as possible.

To illustrate the detailed steps in the analysis of receivers by the resistance method, let us use the circuit shown in Fig. 9. There are two methods of resistance analysis. The first one to

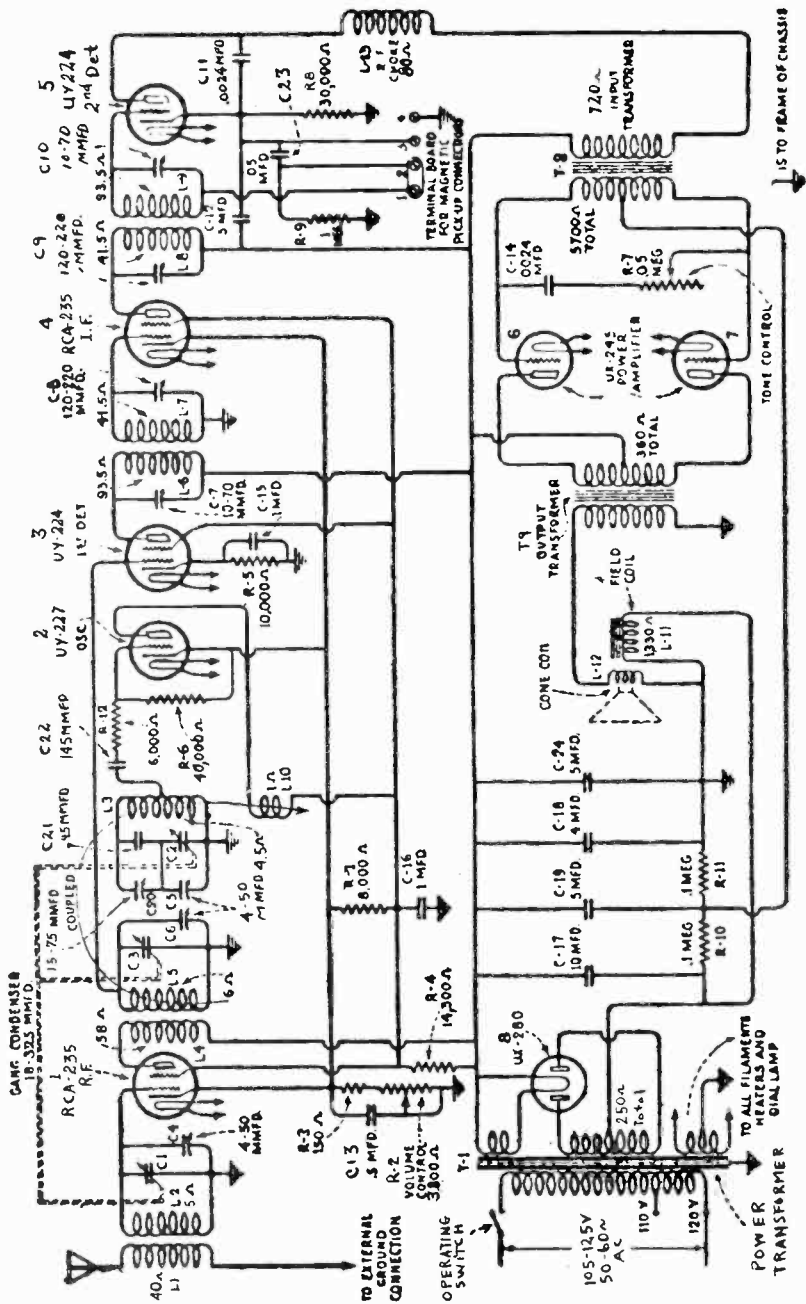

Fig. 9 Circuit used to explain the resistance method of receiver analyzing.

be discussed covers those tests in which the receiver remains in the cabinet. The other method to be discussed later in this lesson covers those tests to be made with the chassis removed from the cabinet.

Before starting the description, it might be well to make certain general statements relative to ordinary basic circuit structure as may be found in radio receivers and amplifiers. We repeat that these are only general statements.

1. There seldom is a direct, presumably zero resistance connection between the plate of a tube and its associated screen grid, if the tube is of a type that has a screen grid.
2. There seldom is a direct, presumably zero resistance connection between a screen grid and the cathode of the same tube.
3. There seldom is a direct, presumably zero resistance connection between the plate and cathode of the same tube. The exception to this is the dual-acting automatic volume control tube (detector and control tubes.)
4. There is seldom a direct, presumably zero resistance connection between the plate of one tube and the control grid of the subsequent tube. One exception to this statement is the direct-coupled amplifier, of which the Loftin-White system is an example.
5. There seldom is a direct, presumably zero resistance connection between the cathode of one tube and the control grid of the subsequent tube. The exception to this rule at the present time is the triple-twin tube.
6. There seldom is a direct, presumably zero resistance connection between the control grid of one tube and the plate of the same tube.
7. There seldom is a direct, presumably zero resistance contact between the filament or the electron emitter of a rectifier and its associated anodes.
8. There seldom is a direct, presumably zero resistance connection between the control grid, screen grid, suppressor grid, or plate of a tube, and ground.

Keeping these facts in mind, let us proceed with our analysis. As a basis for our measurements, we must select some common point to start. There are two possible common points that may be used. One is the chassis or common ground of the receiver, the other is the filament of the rectifier tube. These two points are more or less common with every circuit in the receiver. Actually, there is little choice between them, and in our discussion we are choosing the chassis or ground as a common point, only because it has become standard with most service engineers. However, regardless of which point is used as a common measuring point, it is always the best policy to check each and every circuit connected with each tube as each tube is consider-

ed. Far better results are obtained using this method than when using a hit-or-miss method of skipping around from circuit to circuit.

We shall start with the antenna circuit and R.F. tube and proceed through the circuit in a direct line, assuming that the chassis remains in the cabinet, the aerial, ground and the AC line are all disconnected and that all tubes have been removed from the chassis.

Our first measurement is a check of the R.F. or antenna transformer primary. Examining the circuit diagram we see that the external ground is isolated from the receiver circuit common ground. It is, therefore, necessary to make this measurement between the antenna and ground terminals. In this case, from the values given on the circuit diagram, we see that the resistance should be 40 ohms.

The resistance of the R.F. transformer secondary is checked from the control grid of the R.F. tube to the chassis. This also checks the tuning condenser  $C_1$  and the trimmer condenser  $C_4$  for shorts. An open condenser will not change the resistance reading, but a shorted condenser will give a zero ohms indication in place of the 5 ohms specified on the schematic diagram.

The resistance between the cathode of the R.F. tube and the chassis is a total of the resistance of the volume control  $R_2$  and the bias resistor  $R_3$ . The amount of resistance depends upon the position of the volume control. If the volume control is set for maximum volume (minimum resistance) the total resistance will be 150 ohms. If the volume control is set for minimum volume (maximum resistance), the total resistance between cathode and the chassis will be 3950 ohms. This measurement is also a check for a shorted by-pass capacitor  $C_{13}$ . A zero ohm measurement will be an indication of a shorted capacitor.

In measuring from the screen grid to ground or the chassis, we can see from the schematic diagram that the measurement includes three resistors,  $R_1$ ,  $R_2$ , and  $R_3$ . The total resistance again depends upon the volume control setting. The resistance will be 8,150 ohms with the control set for maximum volume and 11,950 ohms with the control set for minimum volume. At this point suppose we were using the rectifier filament as a common point. In that case, the resistance measurement from screen grid to rectifier would include only one resistor,  $R_4$ . From this we can see that in many cases a combination of both methods of measurement is necessary in order to make a complete analysis.

Measurement from the plate of the tube to the chassis will show a total of either 26,308 ohms or 22,508 ohms, depending upon whether the volume control is at maximum or minimum. This resistance is made up of  $R_1$ ,  $R_2$ ,  $R_3$ ,  $R_4$ , and the primary winding of the R.F. transformer. As we have previously checked  $R_1$ ,  $R_2$  and  $R_3$  in our measurement between the screen grid and the chassis, this is in reality a check on  $R_4$  and the primary of the R.F. transformer. If  $R_4$  was checked between the screen grid and the rectifier filament also, we are then actually only checking the

R.F. transformer primary. The effect of shorted  $C_{1s}$  and  $C_{1e}$  capacitors was discussed in previous paragraphs so no further discussion need be made at this time.

Inasmuch as the total resistance of the R.F. primary is only 58 ohms, which is less than the normal 10% tolerance of the total resistance path measured, it is necessary to make another measurement to make certain that this transformer is not shorted. By examining the circuit diagram we see that a check between the rectifier filament and the plate of the tube will give us this measurement.

While we have one side of the ohmmeter connected to the rectifier filament, it is natural to measure between that point and the chassis. This measurement will give us a check on the bleeder resistor in the power supply circuit. This will cover resistors  $R_1$ ,  $R_2$ ,  $R_3$  and  $R_4$  and, with the volume control at maximum volume, should total 22,450 ohms.

Continuing our tests, and again using the chassis as a common point, we now check the oscillator and its associated circuits. Examining the circuit diagram we note that there is no way of checking the grid winding of the oscillator coil as it is completely isolated from the tube socket by capacitor  $C_{22}$ . However, the oscillator cathode is common with the R.F. cathode so the resistance measurement to the chassis should be the same in both cases.

Between the cathode and oscillator control grid we find the grid leak with a resistance of 40,000 ohms. If the cathode to chassis circuit has a resistance of 3,950 ohms with the volume control at minimum volume, then the resistance from oscillator control grid to chassis should be 43,950 ohms.

The circuit from the oscillator plate to the chassis includes  $R_1$ ,  $R_3$ , and  $R_2$ , in addition to the one ohm resistance in the oscillator coil plate winding. With the volume control  $R_1$  set at maximum volume, this resistance would be 8,151 ohms. Again, however, we have a condition in which the oscillator coil plate winding could be completely short-circuited and the condition could not be noted due to the extremely low resistance of that winding. Therefore, another check must be made to measure the resistance of this coil. Examining the circuit diagram, we see that the oscillator plate is connected to the R.F. screen grid through the oscillator coil plate winding. By measuring the resistance between oscillator plate and the R.F. screen grid, we can check on the plate winding of the oscillator coil.

The next tube and associated circuits to be checked is the mixer or first detector. Tracing from the control grid, we find that it is connected through the R.F. transformer secondary to the chassis. The correct resistance then from control grid to chassis is 6 ohms. If a short-circuit exists in either the tuning capacitor or the trimmer capacitor, a zero ohms indication would be given in this measurement.

Checking the cathode circuit to chassis, we find a resistance of 10,000 ohms due to the bias resistance  $R_6$ . A short in  $C_{1s}$

would result in a zero ohm indication between cathode and chassis. It is noted at this point that no other resistance measurement will check these two parts, as they are completely isolated from all other parts of the receiver.

The screen grid is common with the oscillator plate through the oscillator coil plate winding and also with the R.F. screen grid. This circuit has been checked at both the R.F. and oscillator sockets, but as an open circuit may exist at the junction of these circuits, we again make this check by measuring between the first detector screen grid and chassis. With the volume control set at maximum volume, the resistance should be 8,150 ohms.

The mixer plate circuit to the chassis includes the R.F. transformer with a resistance of 93.5 ohms,  $R_2$ ,  $R_3$ ,  $R_1$ , and  $R_4$ . The total resistance of this circuit, with the volume control set at maximum volume, is 22,543.5 ohms. Once more it is necessary to check the transformer winding by itself, as its resistance is so low compared to the rest of the circuit measured. Examining the schematic diagram, we see that if we measure between the first detector plate and the rectifier filament, we will be measuring only the I.F. transformer primary. This check is doubly important in that it is also a check of the I.F. tuning capacitor  $C_7$  for a short circuit.

Again we have found it is necessary to change to the rectifier filament as a common point. The truth is, if we were using the rectifier filament as a common point, it would be necessary to change over to the chassis common point at times to make some measurements. An example would be the checking of the first detector bias resistor, which can only be measured between the first detector cathode and the chassis. It is shown that a combination of the two methods must be used.

Between the chassis and the control grid of the I.F. tube, we measure the resistance of the I.F. transformer secondary. The resistance of this circuit should be 41.5 ohms. If the trimmer capacitor  $C_6$  should be shorted for any reason, a zero ohms indication would show up the defect immediately. The I.F. tube cathode is common with the oscillator and R.F. tube cathodes. With the volume control set at maximum volume, a resistance of 150 ohms should be found between the I.F. cathode and ground. The reason for setting the volume control at maximum for all measurements is to remove that resistance from the circuit, thus giving greater accuracy to our measurements. As the resistance value of the volume control was checked in our measurements on the R.F. tube, we no longer need to include it in our measurements. The I.F. screen grid voltage supply is common with the R.F. and first detector tube screen grids, and the resistance between the screen grid and ground or chassis should be the same as in those cases of 8,150 ohms with the volume control set at maximum. This measurement should be made as a check for loose or poor connections at the junction with the other screen grid supplies.

The plate of the I.F. tube joins the common voltage supply lead for the mixer plate circuit, which is the rectifier filament.

Accordingly, we can check between the chassis and I.F. plate and find a resistance of 22,491.5 ohms. Once more the value of the I.F. primary winding alone should be determined in order to check for a shorted circuit trimmer capacitor  $C_9$ . This means a test between the I.F. plate and the rectifier filament. The correct resistance is 41.5 ohms.

Next we shall test the second detector circuit. This circuit appears a bit more complex but actually it is fairly simple. With the chassis as one common test point, to reach the control grid it is necessary to work through the one megohm resistor  $R_6$ , the link between terminals No. 2 and No. 1 upon the pickup terminal board, and the I.F. transformer winding  $L_6$ . This winding has a resistance of 93.5 ohms. Now, to detect a short circuit across a 93.5 ohm winding when that winding is in series with 1,000,000 ohms is extremely difficult. Therefore, a supplementary measurement, subsequent to the determination that the circuit between chassis and 2nd detector control grid has a resistance slightly in excess of one megohm, is the resistance test between the control grid and pickup board terminal No. 1. This should be 93.5 ohms if the tuning condenser  $C_{10}$  is not shorted and the winding is intact.

Between chassis and cathode, we find a 30,000 ohm resistance. Associated with the junction of cathode bias resistor  $R_8$  and the tube cathode are two by-pass condensers,  $C_{12}$  and  $C_{23}$ . A short circuit in  $C_{12}$  would influence the total resistance between the chassis and the I.F. tube plate, for the simple reason that with this defect in the circuit, the 30,000 ohm resistor  $R_8$  would be shunted across the  $R_2$ ,  $R_3$ ,  $R_1$ , and  $R_4$  series combination. The same value would be obtained during the previously stated test between the rectifier filament and ground. By the same token, the resistance between chassis and 2nd detector cathode would be less than 30,000 ohms. To be exact, with the volume control  $R_3$  adjusted for maximum signal the total resistance would be about 12,840 ohms.

Based upon this example, you can very readily appreciate that by solving for the effect of short circuits in various by-pass condensers associated with grounded units, we can tabulate a series of ohmic values, which will indicate the condenser shorted. We are not concerned with open circuits in resistors which are isolated from the remainder of the circuit, as in the case of  $R_8$ , when a by-pass condenser ( $C_{12}$ ) is perfect. When the condenser is perfect, but the resistor is open, it will in no way influence the resistance of another complete circuit which is not normally in parallel with the defective resistor.

You will note that the rectifier filament-to-chassis resistance is quite high. With  $C_{12}$  shorted it still remains fairly high, about 12,840 ohms. However, the resistance between the rectifier filament and the second detector cathode would be zero, due to the direct connection via shorted  $C_{12}$ . It would not do, although it could be done, to check the resistance between the I.F. tube plate and the second detector cathode, because of the



presence of the I.F. transformer winding. Under normal conditions, the resistance would be high since it would be necessary to work through  $L_6$ ,  $R_4$ ,  $R_1$ ,  $R_2$ ,  $R_3$ , and up through  $R_8$ .

A short-circuit through  $C_{2,3}$  would manifest its effect in the test between the chassis and the control grid of the second detector tube, since it would place in shunt with the one megohm resistor the 30,000 ohm cathode unit. Furthermore, it would produce a resistance of 93.5 ohms when the circuit between the control grid and cathode were checked. Under normal conditions, this resistance should be approximately 1,030,093.5 ohms.

The plate for the second detector secures its potential through the input A.F. transformer,  $T_2$ , and the R.F. choke,  $L_{1,3}$ . We have found that the normal resistance (volume control set for maximum signal) between chassis and rectifier filament is 22,450 ohms. Working to the plate of the second detector, we must add the A.F. transformer primary resistance and the R.F. choke resistance, a total of 800 ohms, making a grand total of 23,250 ohms. This assumes that the circuit is perfect. You will note that the rectifier filament is the common voltage supply connection. Because of this, we can isolate the A.F. transformer primary and R.F. choke and check the series resistance of these two units by working from the rectifier filament to the second detector plate. This resistance should be 800 ohms.

If the R.F. by-pass condenser  $C_{1,1}$  were shorted, it would create two conditions. The resistance between chassis and second detector plate would be the resultant of 23,250 ohms in parallel with 30,000 ohms, a final value of approximately 13,000 ohms. The second effect would be a total short circuit between the plate and the cathode of the second detector tube, instead of a resistance of approximately 53,250 ohms.

We now arrive at the output tubes. The midtap in the secondary winding of the input A.F. transformer goes to the mid-tap of the voltage divider connected across the speaker field coil utilized as a filter choke, and also to supply the output tube control-grid bias. If you will examine the schematic diagram you will find that the circuit from either one of the output tube grids through one-half of the secondary winding to ground is not only through  $R_{1,1}$ . You will note that the speaker field coil is also connected to ground and that the other side of the field coil is connected to  $R_{1,0}$ . All in all, the field coil is in parallel with the voltage divider, and when working this circuit you must consider the parallel arrangement. The sum of  $R_{1,0}$  and  $R_{1,1}$  is 200,000 ohms. This value in shunt with 1,330 ohms will have very little effect so that substantially the total resistance of the parallel arrangement is 1,330 ohms. However, due to the position in which the output tube control-grid bias voltage lead joins the filter system, the circuit to be considered is that of a 100,000 ohm resistor in series with 1,330 ohms and the complete series combination in shunt with 100,000 ohms. All of the calculation involved can be simplified by disconnecting the speaker field coil. This is common practice in such work. Im-

mediately, the entire circuit is simplified and the resistance between chassis and either control grid is 102,850 ohms, consisting of the resistor  $R_{11}$  and one-half of the input A.F. transformer ( $T_9$ ) secondary.

It is not necessary to disconnect both leads of the speaker field winding. If it is connected to a plug, the plug may be withdrawn. If it is soldered to the circuit, then either lead can be unsoldered.

The total resistance between the two control grids is 5,700 ohms and can be checked by using the two control grids as the points of contact. If the tone control is in good condition, it will have no effect upon the grid-to-grid resistance. However, if the tone control condenser,  $C_{14}$ , is shorted, the resistance between grid and grid will be zero when the variable resistor,  $R_7$ , is adjusted to the mellowest position (all resistance out).

From plate to plate of the output tubes you check the total resistance of the output transformer ( $T_9$ ) primary. This is 360 ohms. This means that each half of the winding has a resistance of about 180 ohms. To check the voltage supply lead, we can work from the chassis to either output tube plate, or from the rectifier filament to either output tube plate. The latter is preferable, because it involves fewer units and lower values of resistance, whereby it becomes simpler to determine a defect in either half of the winding. Of course, the plate-to-plate check would afford an idea of the presence of a defect because of a discrepancy in the measured value of resistance. From chassis to either output tube plate (volume control set for maximum signal), the total resistance would be 22,630 ohms. From rectifier filament to either output tube plate, the resistance would be about 180 ohms.

Now for the rectifier tube. The resistance of the entire rectifier plate winding is 250 ohms, which means that each half is approximately 125 ohms. With the chassis as a common test point, the resistance between the chassis and either anode should be 200,125 ohms. This measurement takes for granted that the speaker field is disconnected. From anode to anode is 250 ohms. The test between chassis and either anode verifies that the 10 mfd. filter condenser ( $C_{17}$ ) is not shorted. If it were, then the resistance between the chassis and either anode would be the resultant of 200,000 ohms shunted by a series combination of  $R_4$ ,  $R_1$ ,  $R_3$ , and  $R_2$ , plus one-half of the anode winding. To check the 10 mfd. condenser, measure the resistance between the rectifier filament and one plate. It should be the sum of  $R_4$ ,  $R_1$ ,  $R_3$ ,  $R_2$ ,  $R_{11}$ ,  $R_{10}$ , and one-half of the rectifier plate winding resistances. If the resistance is 125 ohms, then  $C_{10}$  is shorted. The condition of  $C_{10}$  is indicated by the chassis to output tube grid test (with speaker field disconnected), because if this condenser is shorted, the resistor  $R_{11}$  is shunted by the series combination of  $R_4$ ,  $R_1$ ,  $R_3$ , and  $R_2$ .

The field coil resistance is measured separately. The same is true of the output transformer secondary and the voice coil.

Without knowing what these values are, it is possible to check for a short circuit, since all voice coils and output transformer secondaries, unless they are of the single copper bar type, have some value of DC resistance in excess of .5 ohm. The last test is to connect the speaker field again and measure the total resistance of the parallel circuit.

In our discussion in the preceding paragraphs, we have made all measurements between the prongs of the tube sockets and the chassis or the rectifier filament. Although it is not absolutely necessary, a free-point analyzer is ideal for these measurements, as all of the tube socket connections are brought out to an external point, making measurements far easier than when it is necessary to hunt around in a limited space for the correct socket connection. In this case, of course, the tube is not inserted in the free-point tester, and all tubes are removed from the receiver under test. Also, it is necessary to have a common ground connection between the free-point analyzer and the chassis of the receiver under test. This connection is made either through the analyzer cable or by a special lead separate from the analyzer cable.

This method of analyzing a receiver has taken several pages of our text to explain. However, all the tests described can be made in a short time. In most cases, after such an analysis has been completed, it will be possible for you to judge where the trouble is located, and to give the customer an estimate of the cost of repairing the receiver.

Another method of analysis by resistance measurements involves the removal of the chassis from the cabinet. A check is then made on every part of the receiver. In preparing to make these tests, remove all the tubes from their sockets and remove the power cord plug from the AC supply outlet. When removing the receiver chassis from the cabinet, always use newspapers or a protecting cover of some kind over the floor and carpets of the customer's home. There is always an accumulation of dust and dirt on and around the chassis, and customers do not look with favor upon this dust and dirt when it is carelessly spilled on their floors.

Having removed the chassis from the cabinet, we are ready to proceed with our tests. For our discussion we will use the circuit shown in Fig. 10. In many cases, the service engineer will consume valuable time hunting in the mass of wires, resistors, and terminals for a certain component part. To save this time, most manufacturers include in the service notes on receivers, a diagram of the location of parts such as shown in Fig. 11. In the following discussion, we will not refer to this diagram, but we suggest that the student take the time to locate each point on this diagram as the discussion proceeds. This will enable you to understand more clearly each step as we proceed with the discussion.

As a high percentage of receiver troubles originate in the power supply, our first test will be made on that unit. Using a

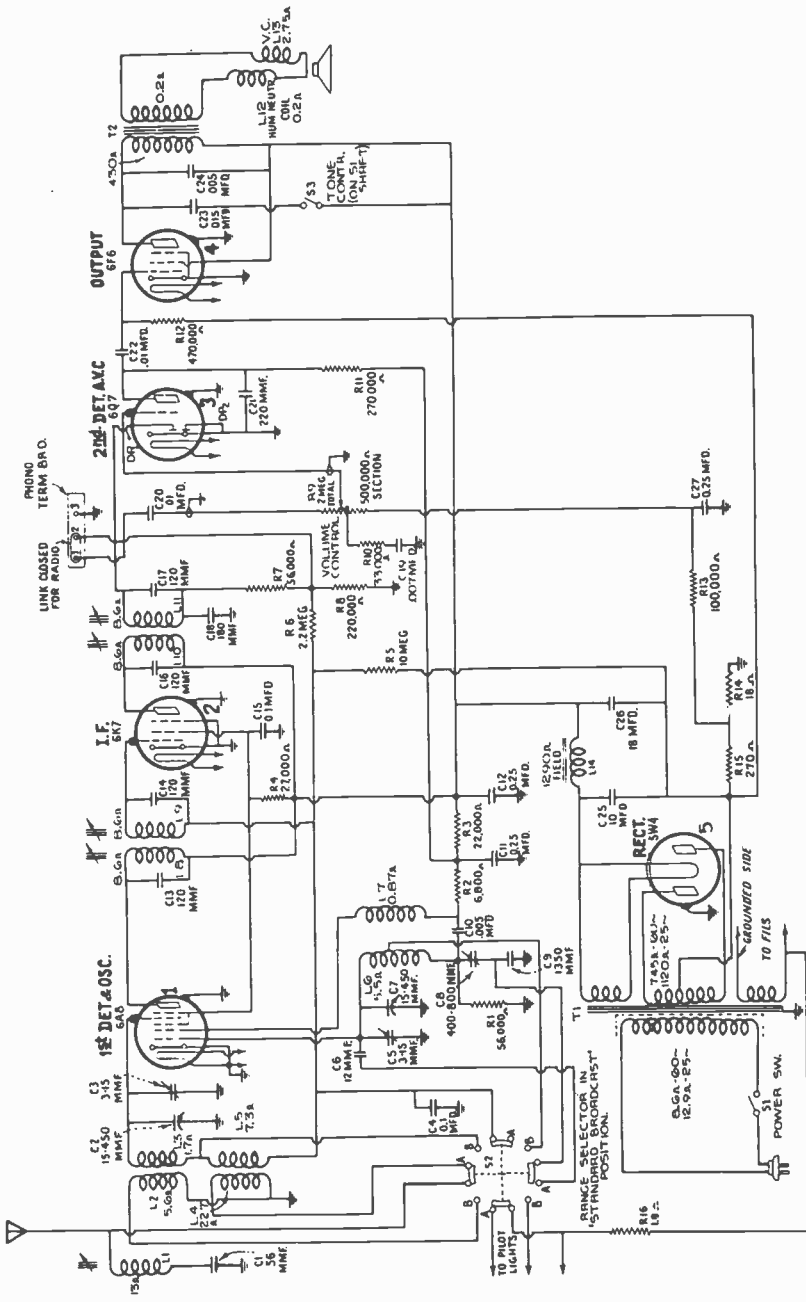

Fig.10 Wiring diagram of a modern superheterodyne receiver.

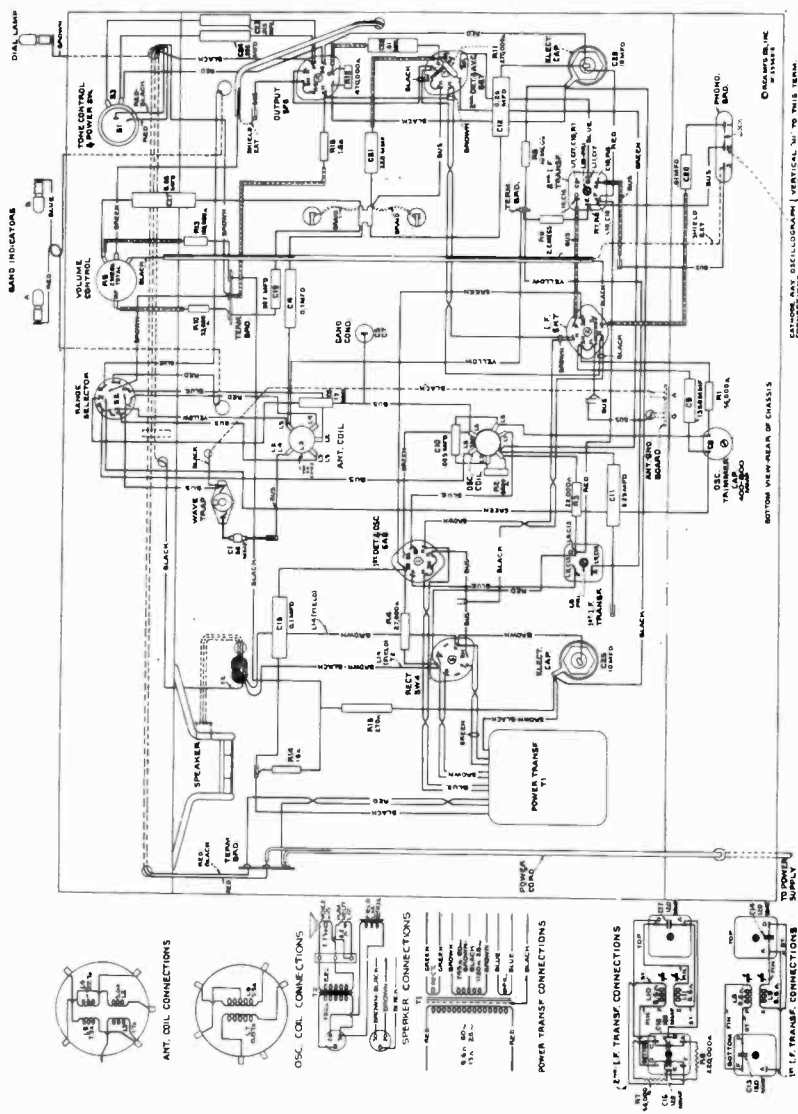

Fig. 11 Layout drawing of the receiver whose schematic appears in Fig. 10.

low range ohmmeter, we measure the resistance of the power transformer primary by placing the ohmmeter across the contacts of the male AC plug with the AC power switch in the "ON" position. As shown in Fig. 10, the resistance of this winding should be 8.6 ohms for the 60 cycle transformer and 12.9 ohms for the 25 cycle transformer. With the AC power switch in the "OFF" position, the resistance should be infinite. We now check the secondary filament windings. The rectifier filament can be measured by connecting the ohmmeter across the filament contacts on the rectifier tube socket. (The rectifier tube is removed). The resistance of this winding should be nearly zero. To test the winding which supplies the filaments of the amplifier tubes and the pilot lamps, first either remove both pilot lamps or at least loosen them in their sockets. To test this winding, the ohmmeter may be connected directly across the winding, or may be connected across the filament contacts at any socket. Looking at the circuit diagram, you will note that the pilot lights are turned on by the band change switch. By removing both pilot lamps from the circuit, the position of the band switch will not affect our measurement on the filament winding.

The high voltage secondary winding is measured by connecting the ohmmeter directly between the two plate contacts of the rectifier socket. The resistance of this winding should be 745 ohms for the 60 cycle transformer and 1120 ohms if a 25 cycle transformer is used. If we measure the resistance between either rectifier plate and ground, the reading should be one-half the total resistance of the high voltage winding plus the resistance of  $R_{15}$  and  $R_{14}$ . This makes a total of 660.5 ohms. This measurement is made as a check of  $R_{15}$  and  $R_{14}$  and saves the time required to locate them and measure the resistance of each unit individually. If the resistance between the plate contacts on the rectifier socket has measured up to specifications, but the resistance between one plate and the chassis is either infinite or only one half the total resistance of the plate winding, we know that either  $R_{15}$  or  $R_{14}$  or both are open or shorted. In such a case, it will be necessary to make measurements on the individual resistors to locate the source of the trouble.

In measuring the transformer windings, if no reading is obtained, it is an indication that the wire in that winding is broken or burned in two. In either case, it is necessary to replace the power transformer. In measuring the primary winding or the high voltage secondary winding, if zero resistance is indicated on the ohmmeter, it is obvious that the winding being measured is shorted. If the short is internal; that is, if it is inaccessible, it will be necessary to replace the power transformer.

The latter condition is often indicated by the overheating of the transformer and by the presence of the very peculiar odor of burned insulation. We don't mean to convey the impression, however, that every overheated transformer is due to an internal short in the transformer. Many times an external shorted resistor or capacitor will cause this condition.

In this particular receiver, the field coil of the speaker is used as a choke in the filter system. Our next check, then, is to determine that the speaker field is connected properly, and also, that it is not open, shorted, or grounded. The first step is to connect a medium or high range ohmmeter between the filament contact on the rectifier socket and ground. Our first impression, as we check the circuit diagram, would be that we should get no reading. However, if we follow the B supply lead through to the various amplifier tubes, we will find that each supply is blocked from ground by a condenser. We therefore, will obtain a high reading to ground, but it will not be infinite, due to the leakage resistance of the various condensers, especially the filter condensers which are usually electrolytics. Our next measurement is between the filament contact on the rectifier tube socket and the opposite side of the field coil, which can be traced through to the screen grid contact on the 6F6 tube socket. This measurement should give us a reading of 1290 ohms if the field coil of the speaker is in good condition.

Having completed our tests on the power supply and its associated circuits, let us now move to the antenna system and the detector-oscillator circuit, and study a typical resistance measurement analysis of these circuits. The coil  $L_1$  and the capacitor  $C_1$  form a wave trap to prevent low frequency signals, close to the I.F. frequency of the receiver, from forming image frequency interference. To test this combination, we first measure directly across the coil  $L_1$  with a low range ohmmeter. The resistance of this coil should be 13 ohms. It is impossible to check capacitor  $C_1$  directly for shorts without disconnecting one lead. Examining the circuit, we find that coils  $L_1$  and either  $L_2$  or  $L_4$ , depending upon the position of the wave band switch, are in parallel with capacitor  $C_1$ .  $L_4$  is the primary coil for the "Broadcast" band, and  $L_2$  is the primary coil for the "Short Wave" band. To get around the necessity of unsoldering the capacitor lead, let us find some other method of making this test. If we measure between antenna and ground with the band switch in the "Broadcast" position, we measure the resistance of the broadcast band primary, which should be 22.7 ohms. However, if  $C_1$  is shorted, the resistance of the primary coil will be in parallel with the resistance of  $L_1$  to ground and a corresponding lower resistance measurement will result. This measurement may also be made between the junction of  $L_1$ - $C_1$  and ground. In this case, if capacitor  $C_1$  is shorted, the resistance measurement will be equal to zero, while if  $C_1$  is in good condition, the resistance measurement will be the sum of the resistances of  $L_1$  and  $L_2$  or  $L_4$ . With the wave band switch in the broadcast position, this resistance will be 35.7 ohms. With the wave band switch in the short wave position, this resistance should be 18.6 ohms. If we obtain approximately these resistance values, it is safe to assume that capacitor  $C_1$  is in good condition, and it will be unnecessary to unsolder the leads to make a special test, unless it is desired to make a capacity measurement.

While we were making the resistance measurements on the wave trap circuit, we also checked the R.F. transformer primaries, so we will next check the R.F. transformer secondaries. To save time, let us check  $L_3$ ,  $L_5$ , and  $L_6$  together. As the tubes have been removed, the grid connecting clips are free. Place a low range ohmmeter between the grid clip of the 6A8 and the grid clip of the 6K7 I.F. tube. Examining the circuit diagram, we see that the resistance between these two points should be the sum of the resistances of  $L_3$ ,  $L_5$ , and  $L_6$ , or 1.7 plus 7.3 plus 8.6 ohms, or a total of 17.6 ohms. This measurement is made with the band switch in the "Broadcast" position. Now if this measurement is found incorrect, we must make further tests. Let us leave our ohmmeter in the same position as in the last measurement, but change the band switch to the "Short Wave" position. In this position, the band switch shorts out coil  $L_5$ , and our resistance measurement will be across  $L_3$  and  $L_6$ , or 10.3 ohms. If necessary, we can check  $L_3$  alone by measuring the resistance between the grid clip connecting to the 6A8 tube and the band switch contact, the top connection of capacitor  $C_4$  or to the junction between  $R_5$  and  $R_6$ . It is only necessary to make this measurement in case the measurements stated above prove that further checks on  $L_3$  are necessary. The combination resistance measurements will often save you valuable time in analyzing a defective receiver.

Now let us check the tuning capacitor  $C_2$  and the trimmer capacitor  $C_3$ . By placing our ohmmeter between the grid clip of the 6A8 tube and ground, we are actually measuring the resistance across  $C_2$  and  $C_3$ . Examining the circuit diagram, we see that between the 6A8 grid and ground there is a series-parallel arrangement of resistors including  $R_6$  and  $R_8$  in one parallel path, and  $R_5$ ,  $R_{15}$ , and  $R_{14}$  in the other. The actual resistance should be in the neighborhood of 2 megohms. If a zero resistance indication is noted, either  $C_2$  or  $C_3$  is shorted, and it will be necessary to disconnect one side of each of these units to test them individually. However, if a resistance of approximately 2 megohms is indicated, our next step is to rotate the main tuning condenser over the entire tuning range. There should be no change in resistance during this operation. If a change is noted, it will be due to a direct short of the tuning condenser, and it will be necessary to separate the plates of that condenser with a small screwdriver at the point where the short occurs. In doing this, extreme care must be taken that the plates are not nicked. It is very easy to damage this unit beyond repair. Also, the rotation of the band switch from the short wave position to the broadcast position (or vice versa) should have no effect upon the resistance reading with the ohmmeter between the 6A8 grid clip and ground.

As we are measuring the resistors included in the parallel path between the grid clip of the 6A8 and ground, our checks automatically tell us the condition of those parts included in the circuit. The value of resistance measured, if not correct, can readily be interpreted to isolate the defective part. To simplify this interpretation and our explanation, we will tabulate the possible resistances and the causes for such readings.



RESISTANCE	CAUSE
Approximately 280 ohms.....	Shorted $R_6$ , 10 megohm resistor.
2.5 megohms.....	Open $R_6$ , " " "
10 megohms.....	Open $R_6$ , 2.2 megohm resistor or open $R_8$ , 220,000 ohm resistor.
220,000 ohms.....	Shorted $R_6$ , 2.2 megohm resistor.
9 ohms.....	Shorted $C_4$ , 0.1 mfd. filter condenser.

In any case, it will be necessary to unsolder one lead of the resistor suspected and make a test on that unit alone to confirm our findings.

Next we will check the various circuits and parts connected with the oscillator portion of the 6A8 tube. Our first check is made on  $R_1$ , which we measure between grid #1 on the tube socket and ground. The resistance should be approximately 56,000 ohms. The oscillator grid inductance ( $L_6$ ) is included in this circuit but its resistance value of 5.5 ohms could not be detected in our measurements of  $R_1$ . If no reading is obtained, either  $R_1$  or  $L_6$  is open and we will have to check each unit individually with the ohmmeter. If a zero resistance measurement is obtained from the 6A8 grid to ground, it is an indication that either  $C_6$  or  $C_7$  is shorted. Again it will be necessary to isolate these units by disconnecting the lead from one end of each unit and measuring them individually. Capacitors  $C_6$  and  $C_7$  are tested by placing the ohmmeter prongs directly across each unit. If the tests show that both  $C_6$  and  $L_6$  are in good condition, it will not be necessary to disconnect one lead of  $C_6$  while making tests.  $C_6$  is tested by placing the ohmmeter prongs directly across it with the band switch in the "Broadcast" position.

To test the oscillator plate coil, the ohmmeter must be placed between the grid #2 contact on the 6A8 socket and the opposite side of  $L_7$ , or to some other point in that circuit more convenient to locate. If the latter course is followed, the added resistance in the circuit must be taken into consideration. As most of the resistors in this circuit are comparatively high, an absolute measurement on the resistance of  $L_7$  will not be obtained. If  $L_7$  is not open, it is safe to assume that its turns are not shorted, as such a condition rarely occurs.

We may next test the plate circuit of the 6A8 and also the plate circuit of the 6K7 I.F. amplifier by connecting the ohmmeter leads between the plate prong on the 6A8 socket and the plate prong on the 6K7 socket. The primary of the first I.F. transformer and the primary of the second I.F. transformer are then in series between the ohmmeter leads. The total resistance should be 17.2 ohms. Should the ohmmeter reading be infinitely high, it indicates that either  $L_8$  or  $L_{10}$  is open. On the other hand, if the ohmmeter reading is only 8.6 ohms, one of the primary windings is shorted, and if the reading is zero, both primary windings are shorted. A shorted primary winding is likely to occur because the condenser plates of  $C_{13}$  or  $C_{14}$  may be touching. By connecting the leads of the ohmmeter from the plate of the 6A8 socket to the fil-

ament contact of the 5W4 rectifier tube socket, the field winding  $L_{14}$  is in series with  $L_6$ . The total resistance reading should be 1298.6 ohms. If this reading is obtained, it indicates that the plate circuit wiring of the 6A8 is all in good condition and that when the tubes are inserted in their sockets, the 6A8 will receive its proper plate voltage, assuming the power supply to be in good condition.

A similar test may be made in the plate circuit of the 6K7 I.F. amplifier by connecting the ohmmeter leads between the filament of the rectifier tube and the plate of the 6K7. A reading of 1298.6 ohms indicates that the entire plate circuit is in good condition.

Next connect the leads of the ohmmeter from the screen grid prong (grids #3 and 5 are internally tied together to form the screen) on the 6A8 socket to ground. The resistance reading should be infinitely high, since there is no DC path between these two points. If zero reading is obtained, then the screen by-pass condenser  $C_{15}$  is shorted. Should a high resistance be obtained, it is probably due to leakage through some of the condensers in the power supply and plate circuits of the other tubes. Such a high resistance reading does not indicate a defective part. Next, connect the ohmmeter leads from the screen grid prong on the 6K7 socket to ground. The same reading should be obtained as when the ohmmeter was connected to the screen grid of the 6A8, because these two grids are tied together.

Now connect the ohmmeter between the screen grid prong on either the 6A8 or 6K7 and the filament of the rectifier tube.  $R_4$  and the resistance of the field winding are now in series, so the total resistance indicated should be 28,290 ohms. Infinite resistance would probably be due to  $R_4$  being open. If it is desired to test  $R_4$  individually, this may be done by connecting from the screen grid prong of either of these tubes to the plate prong of the same tube. The small resistance of the I.F. transformer primary will be in series, but it is such a small percentage of the 27,000 ohms resistance contained in  $R_4$  that it will not be apparent on the ohmmeter scale.

Before leaving the 6K7 I.F. amplifier, the ohmmeter leads should be placed between the cathode prong on the socket, and ground, in order to make certain that the cathode is properly grounded.

Next we shall test the input circuit of the second detector by first connecting the leads of the ohmmeter between DP<sub>1</sub> on the 6Q7 socket and the chassis (ground). The reading obtained should be approximately 275,000 ohms because the secondary of the input transformer  $L_{11}$ ,  $R_7$ , and  $R_8$ , are all in series. The parallel path formed around  $R_8$  by  $R_6$ ,  $R_5$ ,  $R_{15}$ , and  $R_{14}$ , will have a negligible effect on the reading because of the high resistance values of  $R_6$  and  $R_5$ . If the reading is practically zero, then it is likely that  $C_{16}$  is shorted, and if the reading is infinitely high,  $L_{11}$ ,  $R_7$ , or  $R_8$ , is open. If both  $C_{17}$  and  $C_{18}$  are shorted, the reading will be zero.

Next open the link on the phono terminal board and place the leads of the ohmmeter between terminal 2 and ground. The ohmmeter is directly across  $R_8$ , and the reading should be slightly less than 220,000 ohms because  $R_8$ ,  $R_5$ ,  $R_{15}$ , and  $R_{14}$  in series are in parallel with  $R_8$ . The reading, however, should not be decreased to any appreciable extent because the resistance of the parallel path is nearly 12.5 megohms. To make certain that the AVC resistors  $R_7$ ,  $R_8$ , and  $R_5$  are in good condition, the only alternative is to turn the chassis upside down, locate the desired resistors, unsolder one pigtail, and measure each separately.

The volume control may be tested by placing the ohmmeter leads directly across the two outer solder lugs on the potentiometer. The total resistance of the volume control potentiometer is 2.5 megohms, with a tap dividing it into two sections; one is two megohms and the other 500,000 ohms. A bass-compensating filter arrangement is connected from the tap to ground. With the ohmmeter leads connected from this tap to ground, the bass-compensating circuit will not be tested, but instead, the meter will indicate the total resistance of  $R_{14}$ ,  $R_{13}$ , and the 500,000 ohm section. It will, therefore, be necessary to unsolder the top end of  $R_{10}$  from the volume control tap in order to test the resistor  $R_{10}$  separately. Then, to test  $C_{10}$ , the ohmmeter leads may be placed directly across it; (with the upper end of  $R_{10}$  unsoldered) an infinite reading should be obtained. Zero reading with the ohmmeter leads across  $C_{10}$  would indicate that the condenser is internally shorted.

To test  $C_{20}$ , place the ohmmeter leads across terminal 1 on the phono terminal board and the top end of  $R_9$ . A very high reading on the ohmmeter indicates that  $C_{20}$  is in good condition, and, of course, a zero reading indicates that it is shorted. After making this measurement, again close the link on the phono terminal board.

In order to test  $C_{27}$  for a short, place the ohmmeter leads between the bottom of the volume control potentiometer and ground. The resistance of  $R_{13}$  plus  $R_{14}$  will be indicated unless  $C_{27}$  is shorted. If shorted, the reading will be zero. To test  $C_{27}$  for leakage, it is necessary to unsolder the top lead of  $C_{27}$  or the right lead of  $R_{14}$ .

Next place the ohmmeter between the  $DP_2$  prong on the 6Q7 socket and ground. Zero resistance should be indicated. To test the R.F. by-pass condenser  $C_{21}$ , the ohmmeter leads may be connected from the plate of the triode section of the 6Q7 to ground. The plate coupling resistor  $R_{11}$  is tested by connecting the ohmmeter leads between the plate prong of the 6Q7 and the filament prong of the 5W4 rectifier. The total resistance will be  $R_{11}$ ,  $R_9$ , and the resistance of the field coil. This totals 293,290 ohms.

The coupling condenser  $C_{22}$  may be tested by placing the leads of the ohmmeter between the plate of the triode section of the 6Q7 socket and the control grid terminal of the 6F6 socket. The grid leak resistance  $R_{12}$  may be tested by connecting the leads of the ohmmeter from the control grid on the 6F6 socket to ground.  $R_{15}$

and  $R_{14}$  are both in series with this connection; however, they are so small that their effect on the ohmmeter reading is negligible.

Now place one lead of the ohmmeter on the plate prong of the 6F6 socket, and the other lead on the filament of the rectifier tube socket. In series between the ohmmeter leads, we have the 430 ohm primary of the output transformer and the resistance of the field winding, a total of 430 plus 1290, or 1720 ohms. A test of this kind, from the plate of an amplifier tube back to the rectifier, also tests the circuit wiring to make certain that it is not broken at any point. In the above test, if only 1290 ohms is read on the ohmmeter scale, then  $C_{23}$  or  $C_{24}$  is shorted. To determine whether or not this is true, place the ohmmeter leads across the plate and screen grid prongs on the 6F6 socket. Only the 430 ohm resistance of the primary is now between the ohmmeter leads, and if  $C_{24}$  is shorted, the resistance reading will be zero. By opening and closing the tone control switch, the condition of  $C_{23}$  may be ascertained. If zero resistance is indicated on the ohmmeter when the switch is closed, and 430 ohms is indicated when the switch is open; apparently  $C_{23}$  is shorted.

The secondary circuit of the output transformer contains the voice coil, the hum neutralizing coil, and the secondary winding. All of these units are very low in resistance, so it will be necessary to use the lowest ohmmeter range available. To test this circuit, it will be necessary to unsolder one of the connections, thus breaking the completed circuit. This can probably be done most conveniently by unsoldering one of the leads on the rear of the speaker. After the secondary circuit is broken, the low range of the ohmmeter may first be connected across the secondary winding then across the hum and voice coils to determine the condition of each.

All of the circuits and components in the receiver have now been tested. If the entire test has been conducted as directed, then every component and portion of the wiring in the circuit has been placed on test between the leads of the ohmmeter. Certainly the defective part should have been located. Of course, there are still a few possibilities of trouble in the receiver that have not been tested by this method, such as misalignment of the tuned circuits, improper centering of the voice coil in the speaker, etc. If all of the tubes test good, and point-to-point resistance measurements have been made throughout the circuit, and the trouble is still not located, then quite obviously one of these alignment factors is responsible for improper operation of the receiver.

When making a point-to-point resistance analysis, it is important to keep in mind that a manufactured resistor does not always measure the number of ohms specified by its marking or color code. A tolerance of 10% is permissible in all cases, because, unless the resistor is of the precision type, this is the extent of the guarantee by the resistor manufacturer.

In cases of extremely stubborn trouble, it may be found that the defect shows up only when the chassis, components, wiring,

etc., rise to a high temperature, such as that produced during normal operation of the receiver. When this occurs, it is no doubt due to the expansion or contraction of a particular part or section of the wiring, which "opens" and "makes" a circuit as the temperature varies. When cool, the part in question (or the wiring) may be in good condition and, as a result, no defect has been located throughout the point-to-point test. Then, when the tubes are placed in the receiver and it is put in operation, after a few minutes time, the components and wiring become heated to a higher temperature and the trouble appears the same as before. One should always be on the lookout for this type of trouble by questioning the owner of the set before starting to service it. For example, he might ask whether the trouble begins immediately as the set is turned on, or, if it occurs after the set has been in operation for fifteen or thirty minutes. If it is thought to be caused by temperature changes, some engineers have been able to locate the trouble by using a small bathroom electric heater pointed directly at the chassis for a period of about thirty minutes before starting the point-to-point resistance measurements. The small heater will place the components and wiring at approximately the same temperature (or even higher) than that developed during normal operation.

We would again point out that our description of the method of analysis by the resistance measurements has taken quite some time, due to the details given. The student will find that in most cases in actual practice, only a few minutes are required to isolate a defective part. Preliminary tests will usually isolate the trouble to some particular section of the receiver, and then only a few resistance measurements are required to definitely locate the trouble.

Having concluded his tests and having located the defective part or parts in the receiver under test, the service engineer is confronted with the problem of repairing or replacing the defective part, either in the customer's home or in his own service shop. It is generally a good policy to repair the set in the customer's home if this is convenient; first, because of the saving in time, both to your customer and yourself; and second, because of the good will created in the customer's mind by having his receiver in good condition as soon as possible. Obviously, there are some repairs which cannot be made in the customer's home. Generally speaking, then, the replacing of resistors, bypass capacitors, and similar parts can be done in the customer's home. The replacement of I.F. and R.F. transformers should be done in the service shop, where suitable instruments for the realignment of these circuits is available. This same suggestion applies to audio and power transformers, in which case the set should be repaired in the service shop.

After discussing the "voltage-current" analysis and "point-to-point resistance" methods of analyzing a radio receiver circuit, it is evident that each has its advantages, disadvantages, and limitations. The method most applicable depends upon the design of the receiver being serviced, the equipment available,

and the allotted time; or it may be governed entirely by the symptoms that were noted before the analysis was started. Both systems are popular, and both are effective in locating trouble in a modern receiver with its complicated circuits.

The text of this lesson was compiled and edited by the following members of the staff:

G. L. Taylor  
President and Chief Engineer  
Midland Radio & Television Schools, Inc.

C. L. Foster  
Supt. of Instruction  
Midland Radio & Television Schools, Inc.

C. V. Curtis  
Chief Instructor  
Midland Radio & Television Schools, Inc.

R. E. Curtis  
Technical Drafting  
Midland Radio & Television Schools, Inc.

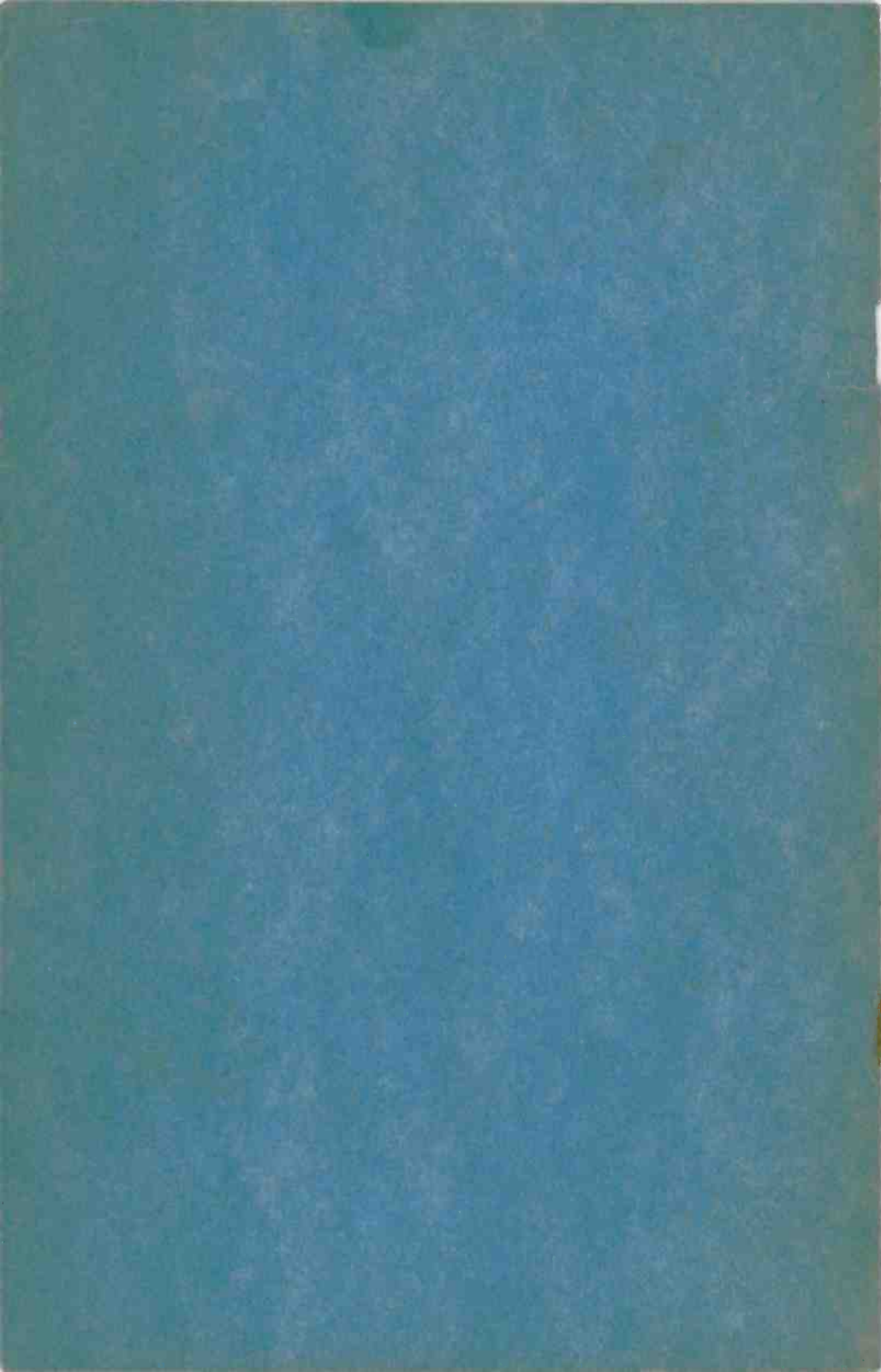





**MIDLAND RADIO  
AND TELEVISION  
SCHOOLS  
INC.**

**POWER & LIGHT BUILDING, KANSAS CITY, MISSOURI**

**UNIT  
NO.  
2**

**ALL - WAVE  
RECEIVERS**

**LESSON  
NO.  
4**

# "I KNOW A FELLOW ..."

We all have used the familiar expression, "I know a fellow that did this or that". Usually we are referring to a person that accomplished something worth while. Perhaps we are inclined to envy him and wonder "how he did it". Well, we know a real, live young fellow that made a big success of the service business in the face of stiff competition. And he is just one of many young men that have entered this field and made good in spite of the advice of friends who said, "Stay out. There are far too many service men."

For the sake of convenience, we will call this young man Frank. He lived in a small, midwestern town where opportunity seemed slight. He had no unusual advantages except plenty of ambition, and a strong desire to be a success and have a business of his own. When he told his friends that he was going to invest in service equipment and start a little shop, they gave him the well-known advice, "stay out". But Frank conducted a personal investigation of the service field, consulted men who were experienced in helping young men succeed, built his little shop and then went after business with determination.

He sent cheerful letters to possible customers, called at their homes, told them about his equipment and how the thorough training he possessed would make it possible for him to render better service. His work was thorough and neat, his charges within reason and he was consistent in always giving his customers a square deal. When business was a little dull, he "hit the pavement" and went from home to home. As a result, his business grew rapidly and he secured the agency for a popular radio receiver. Time passed and he continued to prosper. His net earnings reached the \$200-a-month mark, and continued upward. Then Frank got the agency for another popular receiver.....and he never overlooked a single opportunity to make a sale.

The last we heard of Frank, he had moved to a larger store on Main Street, and his little service shop had grown to a full-fledged business institution.....all this in less than a year and with a small initial investment. How did he do it, you ask? Well, Frank knew radio from A to Z. He was thoroughly trained. He invested his money carefully in equipment that would do the job and that would stand up under use. He greeted the public with a smile, and instead of waiting for business to come to his door, HE WENT AFTER IT.....THEN, WHEN HE GOT THE BUSINESS, HE DELIVERED SATISFACTION IN FULL. Service and sales are rich in opportunity for the man who knows Radio from beginning to end!

P.S. -- Don't forget Television!

Copyright 1941

By

Midland Radio & Television  
Schools, Inc.

PRINTED IN U.S.A.



KANSAS CITY, MO.

# Lesson Four

## ALL - WAVE RECEIVERS



"In Lesson 3 of this unit, we have learned of the basic methods of servicing radio receivers. In that lesson, we purposely used circuits which were comparatively simple, in order to describe more easily the principles under discussion. The methods of radio servicing by "Voltage-Current Analysis" or "Point-to-Point" resistance measurement are equally applicable to the most complicated circuits.

"In this lesson, we will proceed into the more complicated circuits, explaining the theory of these circuits as well as the principal items and parts to be checked in servicing those receivers using such circuits. In addition to special circuits, we will discuss mechanical features which are peculiar to the so-called all-wave receivers. In addition to AVC (automatic volume control) circuits, AFC (automatic frequency control) circuits, High Fidelity receivers, and noise suppression circuits, we will discuss such mechanical items as methods of band changing, dials and dial drives, push-button systems, as well as resonance or tuning indicators. Each of these subjects will be discussed in detail to introduce you thoroughly to the principles involved."

1. GENERAL DESIGN REQUIREMENTS OF ALL-WAVE RECEIVERS. In the past few years, the All-Wave receiver has been steadily increasing in popularity until at the present time, the majority of sets in use are of that type. Even the small, so-called "midgets" often have at least two bands. It is important then, that the service engineer have a thorough knowledge of the various circuits and components in these receivers to enable him to adjust and repair them in a satisfactory manner. Even though the circuits employed in all-wave receivers are fundamentally the same as those used in single-band receivers, there are very definite differences in electrical and mechanical design. These differences are caused by the higher frequencies encountered and the somewhat involved switching arrangement that must be used to switch from one frequency band to another.

First, let us understand what is meant by the term "All-Wave" receiver. Up until recently, this term was used to designate any

receiver which covered any frequency band other than, and in addition to, the standard broadcast band (550 to 1600 kc.). As a result, the average person buying an "all-wave" receiver might be easily misled by an unscrupulous salesman into buying a receiver which in reality was only a two-band receiver. To overcome this confusion, the Radio Manufacturers Association ruled that the term "all-wave" should be applied only to those receivers which cover all frequencies from 540 kc. to 18,000 kc. In our discussion, we will use the term "all-wave" in a broad sense. Our remarks will apply directly to a receiver covering the frequency range from 540 kc. to 18,000 kc.; however, the principles to be discussed will also apply to those receivers of two, three, or four frequency bands.

Due to the difficulties encountered with TRF (tuned radio frequency) receivers in the reception of high frequencies, practically all modern all-wave receivers are of the superheterodyne type. For that reason, all of our discussion in this lesson will be based on superheterodyne circuits.

2. BAND CHANGING. In all-wave receivers, the method of changing from one band to another is quite important. Fundamentally, it would be possible to change the frequency range of a receiver either by using a single inductance coil and changing the

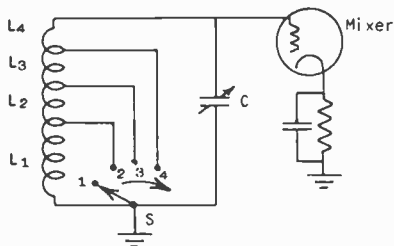

Fig. 1A Single, tapped coil used for band-changing.

value of tuning capacitors, or by using a single tuning capacitor and multiple-tapped inductances. Due to problems in design that are not of interest to us at this point, all commercial receivers have adopted the single tuning capacitor method of design.

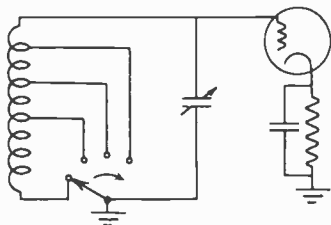
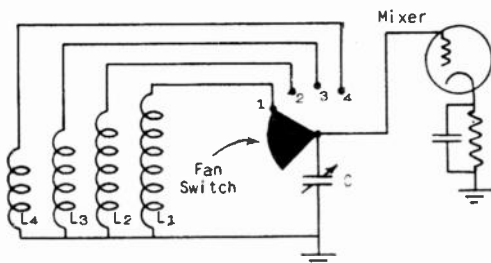

Fig. 1B Another method of band-changing, in which unused portion of coil is left open.

Two methods of changing the values of inductance are available. In the first place, it would be possible to have one set of coils for each band of frequencies and to change the coils manually when a different frequency range is to be used. This is known

as a "plug-in" coil arrangement. Although this system is used quite extensively in amateur receivers, the inconvenience makes it impractical for use by the average user in the home. For that reason, all modern receivers employ a switching arrangement which selects automatically the coils or sections of coils to be used for that particular band. The same tuning condenser is used on all frequency bands, and the change to the higher frequencies is obtained by placing a lower value of inductance across the tuning condenser.

Fig. 1C Parallel inductances used for band-changing.



There are several methods of changing the inductance to a lower value to enable tuning over the higher frequency bands. Four possible methods of band switching are shown in Fig. 1. In Fig. 1A, a single coil tapped at various points to give the correct inductances is shown. The switch S shorts out that portion of the coil that is not being used. As the switch is rotated from position 1 to position 2, position 3, and position 4; less inductance is included across the tuning condenser, and a correspondingly higher frequency band is covered. When the switch is in

Fig. 1D Band-changing arrangement in which a different inductance is used for each frequency.

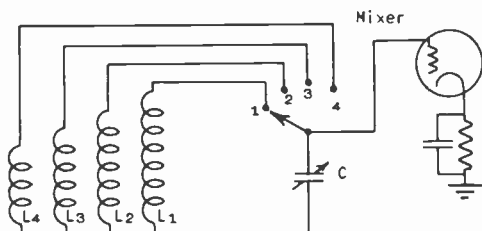

position 1, the entire inductance, consisting of L1, L2, L3, and L4, are in series and connected across the tuning condenser. With this connection, the lowest frequency band is covered by the tuning condenser. When the switch is in the number 2 position, only L2, L3, and L4, are across the tuning condenser, as L1 is shorted out. Consequently, a higher frequency band will be covered. In position 3 of the switch, both L1 and L2 are shorted by the switch, and L3 and L4 are across the tuning condenser C. In position 4, only L4 is in the circuit, and so the highest frequency band will be covered.

Fig. 1B shows a system very similar to that shown in Fig. 1A. In this system, instead of shorting the unused portion of the

inductance, it is left open. This system is preferable to that shown in Fig. 1A, due to the fact that the short-circuited coils absorb a great deal of energy, thus greatly reducing the efficiency of the receiver as a whole.

A third method employed by some manufacturers is shown in Fig. 1C. In this arrangement, the standard broadcast coil is L1, and the smaller coils, L2, L3, and L4 are connected in parallel with L1 by means of a fan switch as it is rotated to the right for the higher frequency bands. When inductances are connected in parallel, the effective inductance is less than the smallest; hence, when the fan switch is turned to that position where all four of the contacts, 1, 2, 3, and 4, are shorted, the total inductance across the tuning condenser C is then at its lowest value. As the switch is moved toward the left, removing the shunt inductance of L4, then only the upper terminals of coils L1, L2, and L3 are connected together, and the total inductance across the tuning condenser C is increased, thereby tuning to a lower frequency band. When the band switch is in such a position as to shunt only terminals 1 and 2, the effective inductance of L1 and L2 is across the tuning condenser. This inductance value will be higher because coil 3 has been removed, so the frequency range covered will be lower than before. Rotating the switch completely to the left leaves only coil L1 across the variable condenser C; hence, the lowest frequency range will be tuned.

Another popular method of coil switching is shown in Fig. 1D. In this arrangement, entirely separate coils are switched into the circuit when reception on a different band is desired. Each of these coils must be properly designed so as to tune the desired range of frequencies. The coil L1, being the largest, will tune the lowest frequency band, generally 540 to 1600 kc. When switched to position 2, the inductance L2 only is across the tuning condenser C. L2 is designed to have less inductance than L1; hence, a higher band of frequencies will be tuned. The same is true as the switch is rotated to positions 3 and 4; that is, at each position a higher frequency range will be covered as the tuning condenser C is rotated.

The coil switching circuits shown in Figs. 1A, 1B, 1C, and 1D, illustrate how the secondaries of the R.F. transformers are changed by the waveband switch. It is common practice to provide each secondary coil with its own primary winding; hence, these separate primaries must also be switched in and out with their respective secondary as the waveband switch is rotated. Then, too, it is necessary to change the tuning circuit in not only the first detector stage, but also in the oscillator and R.F. stage (if an R.F. stage is used). The oscillator tuned circuit must be properly designed so as to maintain the oscillator frequency above the resonant frequency of the first detector and R.F. tuned circuits by an amount exactly equal to the intermediate frequency, regardless of the band selection.

In most modern receivers, a multiple tap, ganged switch is employed to change the various secondary and primary coils with a

single knob as reception is desired on the various bands. These multiple-tap switches are generally wired so as to short-circuit the preceding lower frequency coil when separate coils are used for tuning each band. The object of this is to prevent "dead spots" on the tuning range. Dead spots are those places on the dial where the receiver is very weak or totally inoperative. They are generally caused by absorption effects, due to the resonating of the unused coils. Should the distributed capacity and the inductance of the lower frequency coil tune to some frequency in the next higher band, then when that certain frequency in the higher band is approached by rotating the tuning condenser, the resonating lower frequency coil will absorb energy from the higher frequency tuned circuit, thus greatly reducing or entirely preventing reception. By short-circuiting the lower frequency coil, this absorption of energy is prevented, thus eliminating the "dead spots".

In the oscillator tuned circuit, the coil switching arrangements are the same as previously discussed, with the exception that each range selected must be provided with its own series padding condenser. These condensers are automatically switched in the oscillator circuit as the waveband switch is changed. Shunt padding condensers may be used in the oscillating circuit; however, the series type is the more popular. Most of the modern oscillator circuits employed are of the conventional inductive feed-back type. Generally, a single plate coil is employed and is magnetically coupled to the grid end of the tuned grid coil. The grid coils are individually connected in the oscillator tuned circuit as the waveband switch is rotated. In the oscillator tuned circuit, it is not common practice to short-circuit the lower frequency coil that is not in use. This is because the eddy currents set up in the appreciable mass of copper comprising the shorted or unused portion of the coil would cause a considerable amount of R.F. energy to be absorbed from the oscillator, which may stop it from functioning at some frequencies.

There are actually two possible methods of switching the coils from one band to another. The first involves the mounting of the coils on a rotating or moving panel and shaft in such a manner that the coils are moved into the desired position to make contact with the circuits of the receiver. This system, although having the advantage of giving more positive contacts, is quite expensive, and, for that reason, is seldom used. In place of this method, modern all-wave receivers now mount all coils directly on the chassis and make all circuit changes by means of a rotary tap-switch, which usually has several gangs or decks, depending upon how many bands are included in the receiver.

Regardless of whether the individual coils are rotated into the proper position, or whether the coils are stationary and selected by a multiple-tap switch, it is quite essential that the numerous contacts made by the switching arrangement be as secure as possible. A contact must have an extremely low, non-variable resistance; there must be a low capacity between the contact



points on the switch and negligible insulation losses. Several types of multiple-tap selector switches are available; however, the one most commonly used in all-wave receivers is the rotary "gang" or "deck" switch which contains one or more wafers of insulating material on which the contact points are mounted. The construction of a switch of this type is shown in Fig. 2. These

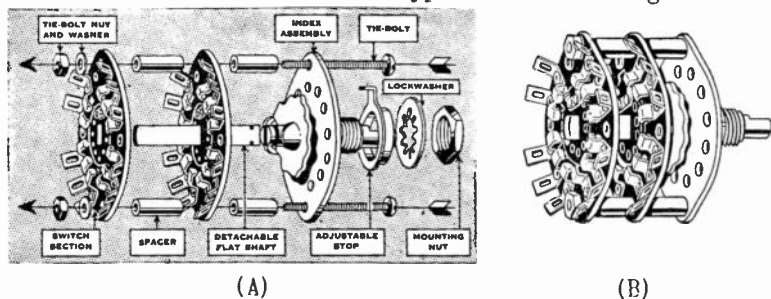

Fig. 2 (A) A disassembled two-deck switch. (B) Assembled two-deck, multiple-tap switch.

selector switches are supplied with an adjustable stop which permits a selection of from two to eleven positions. The drawing in Fig. 2A shows a two-deck switch disassembled to indicate the various parts. In Fig. 2B, the two-gang switch is shown assembled. Fig. 3 shows a similar switch with two additional gangs. The mounting wafers in the switch sections are composed of an insulating material especially designed to withstand the necessary voltages and produce minimum capacity between the contacts. All of the contact points should be made of a type of metal that has a low surface-to-surface contact resistance. Silver is the best for this purpose, and is used extensively in the better type switches. The average contact resistance of silver is about .003 ohm.

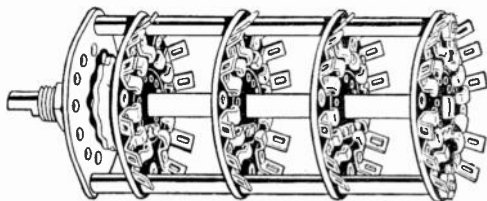

Fig. 3 Four-deck multiple-tap switch.

The slightest variation in contact resistance in a radio tuning circuit means amplified noise. High contact resistance is nearly always the result of disuse rather than wear. When switches are not operated for a period of several months, the contacts are likely to become covered with an injurious film, due to the corrosive effect of the atmosphere. This film tends to increase the contact resistance. Broad tuning and low volume are the common symptoms of defective switch contacts.



The wave-change switch in a modern all-wave receiver appears quite complicated. The multiplicity of wiring to and from the switch, as well as inter-connections between the switch points on the various decks, makes an accurate and exact inspection of the switch nearly impossible. An ohmmeter will be found very helpful in checking wiring through these switches. It is important not to disturb the wiring to and from these switches when servicing all-wave receivers. The original wiring by the manufacturer was made quite carefully, and he did not intend that it be changed in any manner. Should a replacement of the entire switch or any one gang on the switch be found necessary, the wiring should be returned exactly to its former position. All switches possess a certain amount of capacity between those wires that are close to each other on the same section of the switch. The total capacity introduced by the switch and wiring was taken into consideration by the designer of the receiver when calculating the capacity to be used in the various tuned circuits. Should any radical change be made in the switch or wiring, especially in the oscillator circuit, difficulty is certain to be encountered, and future operation of the set will no doubt be unsatisfactory.

In addition to the other requirements of all-wave receivers, it is also essential that the shielding of the various coils in the oscillator, R.F., and first detector sections of the receiver be extremely efficient. The size and kind of shields employed in the original design are correct to produce the proper inductance and distributed capacity of the coil to tune the required frequency range. Upon servicing, should it be found necessary to replace any of these shields, an exact duplicate should be secured from the manufacturer. If the size of the shield, or its position relative to the coil is changed, the operation of that particular tuned circuit will be different from the others. The ground connections on the coil shields, or for that matter, the grounds throughout the entire tuning system, are especially critical on the higher frequency bands. No attempt should ever be made to alter a ground connection from the position originally established by the manufacturer.

3. MODERN DIALS AND DIAL MECHANISMS. Dials and dial driving mechanisms on modern all-wave receivers are somewhat complicated in construction. This condition has been brought about by two major factors. In the first place, the average customer, when purchasing a receiver, will demand a set that is easy to tune, and also one which gives a quick and accurate indication of the frequency at which the receiver is operating. Secondly, tuning throughout the short-wave ranges is so sharp that it is necessary for the dials to have a high drive ratio in order to locate easily the short-wave stations. In some instances, a double drive ratio is used, the lower ratio being utilized for rapid spanning of the frequency range, and the higher for fine adjustment of the tuning. This change in ratio is usually obtained by a movement of the tuning knob. Ratios of as high as 60 to 1 are some times employed for this purpose.

The first requirement of an indication dial and drive mechanism is that there be no possible change in calibration due to slippage. For this reason, the majority of tuning mechanisms use a cord to connect the tuning shaft, the dial indicator, and the condenser gang. With this connection, only a break in the cord will upset the calibration between dial indication and gang setting. The simplest form of this system is shown in Fig. 4.

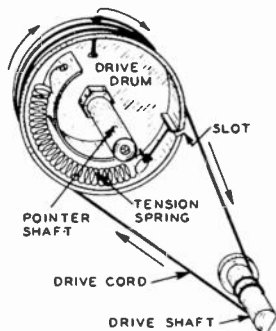

Fig. 4 Modern type of dial driving mechanism.

In this unit, the drive drum is mounted directly on the condenser gang shaft. The pointer, (not shown), is fastened to the pointer shaft after the dial has been assembled on the chassis. The drive cord is looped over the drive drum and fastened at the

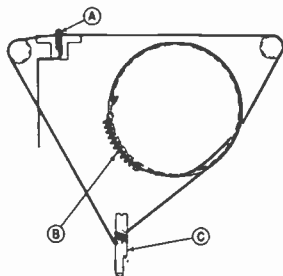

Fig. 5 Dial driving mechanism for horizontal dial.

upper center. It is then looped over the drive shaft and back to the drive drum where it is tied to the tension spring. The tension spring is used to take up slack in the drive cord caused by stretching, due either to aging or atmospheric conditions. The drive drum may be anywhere from 2" to 4" in diameter. Of course, the greater the diameter of the drive drum, the higher the drive ratio. This type of system is found in most of the small or midget type receivers using the so-called airplane type dial.

Fig. 5 shows a more complicated system of dial drive mechanism. In this system, the dial is horizontal, as shown in Fig. 6, and therefore, the indicating pointer must move in a straight line. In Fig. 5, C is the drive shaft, B is the drum on the tuning gang shaft, and A is the indicating pointer. The cord is fastened both to the drum and the pointer, thus insuring that

these two units maintain their relationship at all times. The spring is always fastened to that end of the cord which is between the tuning shaft and the drum, so that most of the stretch in the cord is taken up between these points.

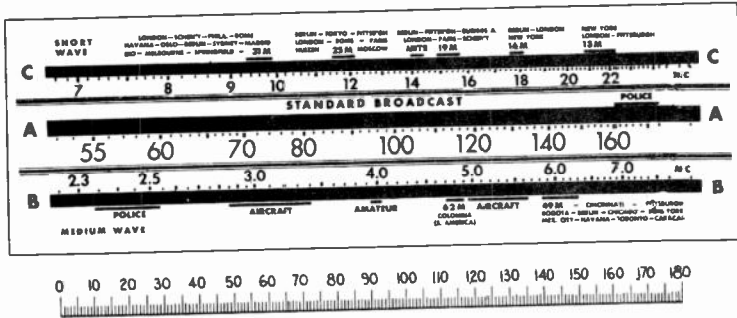

Fig. 6 Horizontal dial as used with dial driving mechanism shown in Fig. 5.

Fig. 7 shows another system which looks still more complicated, but upon examination we find that there are actually three indicating systems. The main tuning drive is started from shaft 2 over the tuning drum and then to the indicating pointer using the idler pulleys at the upper left and upper right. The drive cord 8, pointer 9, and drive shaft 7, are an assembly in themselves, and act as an indicator of the position of the volume

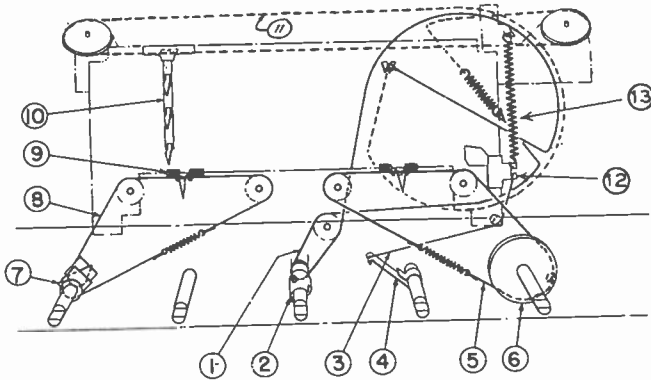

Fig. 7 Showing dial driving mechanism for frequency, volume, and tone controls.

control. The drive cord 5, and drive shaft 6 with its associated pointer, accomplish the same purpose for the tone control. Finally, we have the band indicating system with drive cord 3; drive shaft 4, which is also the shaft of the wave band switch; the indicator 12; and the spring 13. The spring acts purely as a return for the indicator.

Having studied some of the methods of indicating the frequency at which an all-wave receiver is operating, our next question involves the method of indication of what band is being used. As described in the previous paragraph, Fig. 7 shows one method of accomplishing this purpose. The indicator 12, points to the band being used, on a suitable scale on the dial of the receiver.

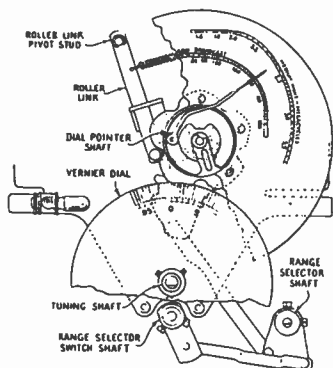

Fig. 8 Dial mechanism used on some of the later model receivers.

Fig. 8 shows another method of indicating what frequency band is being received. The scales for all bands are printed on a single fan-like card. This card is operated by a lever system from the range selector switch shaft. Movement of the range selector switch throws the correct range dial in front of an opening in the main dial. This opening is only large enough to show one dial scale at any one position of the range switch. In the case of the straight line dial, a system very similar to that shown in Fig. 8 is used. In place of a moving dial, a mask is placed in front of the dial light so that only that scale being used is illuminated.

4. AUTOMATIC VOLUME CONTROL. In Lesson 30 of Unit 1, we discussed the basic principles of AVC. Due to the rapid advancements made in receiver design, several auxiliary circuits have been introduced which overcome some of the inherent disadvantages of AVC. These improvements include delayed AVC and amplified AVC which will be discussed in the following paragraphs; and noise suppression circuits, tuning indicators, and Automatic Frequency Control which will be discussed later in this lesson.

To review the fundamental principles of AVC action, let us examine Fig. 9. In this circuit, a type 6B7 duplex diode pentode is used for diode detection, AVC voltage development, and also as the first A.F. amplifier. The diode plates of the 6B7 are tied together and form the anode of a diode detector. When a modulated I.F. signal is developed across the tuned secondary of the last I.F. transformer, a rectified current passes from the cathode to the diode plates and through the circuit of S2, K3, and K2. The high frequency component of the rectified signal is then by-passed

through  $C_3$ ; consequently only the audio frequency signal component of the modulated I.F. signal passes through the resistors  $R_3$  and  $R_2$ . The A.F. voltages developed across  $R_2$  (volume control) are fed through capacity  $C_2$  to the control grid of the pentode audio amplifier. The full voltage drop developed across  $R_2$  by the DC component constitutes the automatic bias voltage for the R.F. amplifier, while a tap is provided for the first detector and I.F. bias voltages. The AVC voltage to each stage is fed through the proper filtering arrangement so as to insure the application of a pure DC bias voltage to regulate the sensitivity of the amplifying stages. The DC component of the plate current through the pentode section of the 6B7 develops a voltage across  $R_1$  which supplies the necessary bias for the pentode audio amplifier. The A.F. output of the pentode section of the 6B7 is delivered through the coupling condenser  $C_6$  to the grid of the power output tube.

Fig. 9 A second detector circuit using simple AVC.

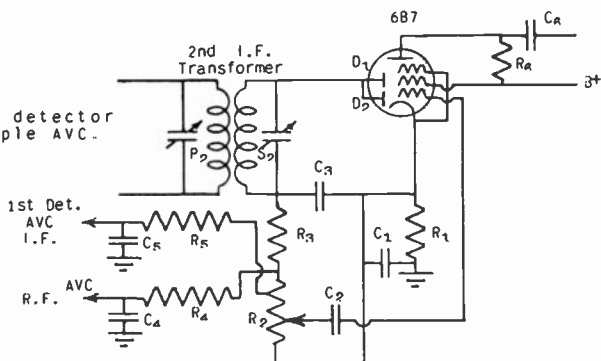

The automatic bias voltage developed across  $R_2$  varies in direct accordance with the average strength of the I.F. signal delivered to the diode plates. This means that if the input I.F. signal increases, the bias voltage developed across  $R_2$  will also increase. Since this increased bias voltage is in turn applied to the grid circuits of the controlled amplifying tubes, the transconductance (and amplification) of each stage will decrease. Reducing the sensitivity of the amplifying stages in this manner decreases the input I.F. signal to the second detector diode. Thus, a fairly constant A.F. output voltage is secured from the detector circuit, even though the original strength of the received broadcast signal varies over a wide range.

In an AVC circuit as simple as outlined in Fig. 1, the detector output voltage is not absolutely constant over a wide range of antenna signal voltages, but rather shows a gradual rise as the antenna signal becomes stronger. Regardless of this deficiency, there is a decided improvement in performance over those receivers which do not employ AVC at all. The main reason for using an AVC circuit of this design is to prolong the overload point of the receiver beyond the value that would otherwise exist.

In addition to prolonging the overload point of a receiver, an AVC circuit should also serve to maintain the A.F. output from the second detector as nearly constant as possible. The graph shown in Fig. 10 illustrates how the detector output voltage varies with the input signal strength when only a simple AVC circuit such as that shown in Fig. 9 is employed. Obviously, this does not fulfill properly the second aforementioned requirement, because it is observed from the graph that the detector output voltage shows a gradual rise as the input signal increases in strength.

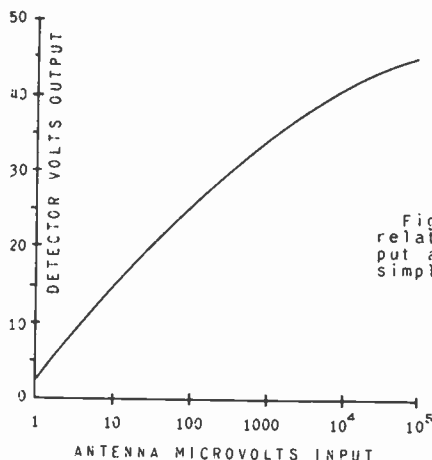

Fig. 10 Graph illustrating the relation between the antenna input and the detector output in a simple AVC circuit.

To correct this undesirable condition, it is necessary to incorporate an additional circuit in the design of the second detector and AVC system to delay the AVC action. The delay circuit will produce a bucking voltage against the signal which must be overcome before the automatic bias voltage is developed for application to the controlled tubes. The manner in which this "delaying" or "bucking" voltage is secured varies in different circuit designs; however, in all cases, the purpose is the same. In a delayed AVC circuit, the detector output voltage will increase in direct proportion to the input R.F. signal until a certain point is reached; then for all higher antenna signals, the output voltage from the detector will remain fairly constant. The potential at which the change occurs is commonly known as the "threshold voltage". This point is indicated in Fig. 11. Signals weaker than the threshold voltage are amplified with the full sensitivity of the R.F. and I.F. sections of the receiver, but input signal voltages exceeding the threshold voltage are suppressed in amplification, due to the development of the automatic bias voltage in the second detector circuit. Even with delayed AVC, the detector output voltage will not remain absolutely constant, but it is indeed a decided improvement over the simple undelayed system. The graph shown in Fig. 11 illustrates the

performance of a typical receiver equipped with delayed AVC. A comparison of Figs. 10 and 11 shows the advantages which may be gained by employing a delayed AVC circuit. Notice that the weaker input signals such as 10 microvolts, receive more amplification when the delay circuit is employed than they do when it is not used. This, of course, is due to the fact that no automatic bias control voltage is developed in the delay circuit until an input signal of approximately 50 microvolts is reached; thus, throughout the range of weaker signals, the full sensitivity of the set is realized.

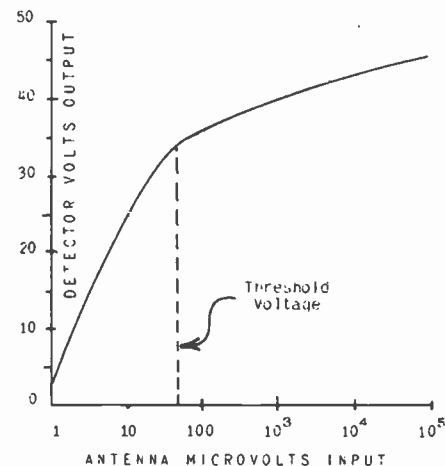

Fig. 11 Graph showing the effect on the AVC curve when a delay voltage is employed.

Before discussing the methods of developing the delay bias voltage, let us investigate a typical circuit, such as shown in Fig. 12, to learn the action of the delay rectifier.

The battery E connected between the cathode (ground) and K1, is supplying the necessary delay voltage. The negative terminal of the battery is connected toward the diode plate; hence, the plate of the diode is biased negatively with respect to the cathode under no-signal conditions. The application of a modulated I.F. signal voltage to the diode circuit causes corresponding voltages to be developed across the resonant circuit L1C1. When the direction of this voltage is such as to make the plate of the diode positive and the cathode negative, it tends to overcome the negative voltage to the plate, but a current flow will not be established through the diode circuit until the voltage across L1C1 exceeds the value of battery E. In other words, the diode current is "delayed" until sufficient I.F. voltage is developed across L1C1 to exceed the potential of the battery. When the voltage produced across L1C1 is greater than the voltage of battery E, diode current will then flow through the circuit from the cathode to the plate, through inductance L1, through the diode load resistor K1, through battery E, and back to the cathode. Condenser C2 serves to by-pass the high-frequency component of the

diode current, and the A.F. component passes through R1 to develop the A.F. voltages, which are in turn fed through C4 to the A.F. circuit. The DC component of the current through R1 is applied through the filter R2C2 to the grids of the amplifying stages; thus automatically controlling the negative bias on these tubes.

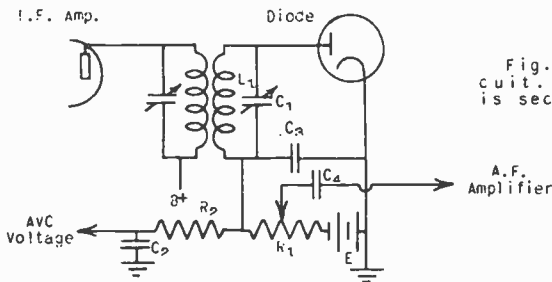

Fig. 12 Delayed AVC circuit. The delay voltage is secured from battery E.

The circuit in Fig. 12 illustrates the action of a delayed AVC system; however, it has no practical application, because the weaker signals (those below the threshold value) cannot establish a diode current, due to the negative voltages on the diode plate with respect to its cathode. Without diode current, there will be no A.F. generated across R1. To correct this condition, one solution is to revert to the use of two separate tubes, one for a

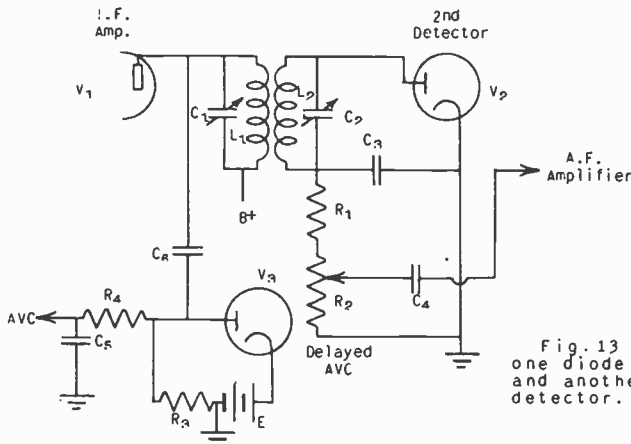

Fig. 13 Circuit using one diode for delayed AVC and another as the second detector.

detector and the other for developing the delayed AVC voltage. Another solution is to incorporate a multi-element tube wherein the various sections of the tube can be used individually for the desired purposes.

A practical circuit illustrating how this may be done is shown in Fig. 13. The modulated I.F. signal voltage in the plate circuit of the last I.F. amplifier (V1) is inductively coupled



into the resonant circuit L2C2. This supplies the exciting voltage to the plate of the diode second detector (V2), and a rectified current flows through the diode load resistors R1 and R2. The A.F. voltages developed across R2 are coupled into the grid circuit of the first audio amplifier through C4. No attempt is made in the diode detector to supply the delayed AVC voltage. Instead, this voltage is secured from a separate diode rectifier, V3. The plate of V3 is coupled to the plate of the last I.F. amplifier through C6, and the plate is biased negative with respect to the cathode by battery E. When a sufficient amplitude of modulated I.F. signal voltage is developed at the plate of V3 to exceed the voltage of the delay battery E, a rectified current flows through the load resistor R3. The DC component of the voltage developed across R3 is applied through the filter R4C5 to the amplifying stages in the receiver, thus controlling their sensitivity.

The object of using separate diode rectifiers in the foregoing circuit is to make possible the development of a delayed AVC voltage and, at the same time, permit the demodulation of weaker input signal voltages which are insufficient to overcome the delay voltage. Thus, the sensitivity of the amplifiers in the receiver is at maximum for the reception of all weak signals, and these signals are properly demodulated by the second detector and fed to the A.F. amplifier without any AVC action. On strong antenna signals, however, the strength of the modulated signal appearing at the plate of the last I.F. amplifier is sufficient to overcome the potential of the delay battery and the AVC circuit is set in operation. The AVC voltage developed across R3 decreases the sensitivity of the amplifying tubes, thus reducing the output of the receiver in keeping with the results expected from an AVC circuit.

In Fig. 13, the delay voltage is supplied by a battery; however, this is not common in modern receivers. Instead, this voltage is secured from some portion of the receiver, such as across a section of the voltage divider.

With the perfection of modern duplex-diode triodes and duplex-diode pentodes, it is now possible to employ a single tube to perform the simultaneous operations of detection and generation of the delayed AVC voltage. In addition, the triode (or pentode) section of the tube serves as the first A.F. amplifier. Duplex-diode triode tubes available for such application are the 75, 85, 6Q7, 6R7, 1B5, 55, and 2A6. The 2B7, 6B7, 1F6, and 6B8 are similar in application to those just mentioned except that the audio amplifier section is a pentode rather than a triode.

The circuit connections for using a duplex-diode triode to perform the operations just mentioned are shown in Fig. 14. The modulated I.F. voltage is delivered from the plate circuit of the I.F. amplifier V1 into the tuned circuit L2C2. Corresponding I.F. modulated voltages are developed across L2C2. Demodulation of the modulated I.F. signal is secured by diode plate D1. The voltages developed across L2C2 cause a rectified current to flow through

the diode circuit from the cathode to D1 through L2, R1, and return to the cathode through the common ground connection. Condenser C4 by-passes the high-frequency component of the rectified diode current, and the audio voltages developed across R1 are applied through C5 to the grid of the triode section of V2. This demodulating circuit is entirely separate from the diode circuit which develops the delayed AVC voltage. Merely because both of the diode plates have a common cathode does not mean that they are interdependent in any way.

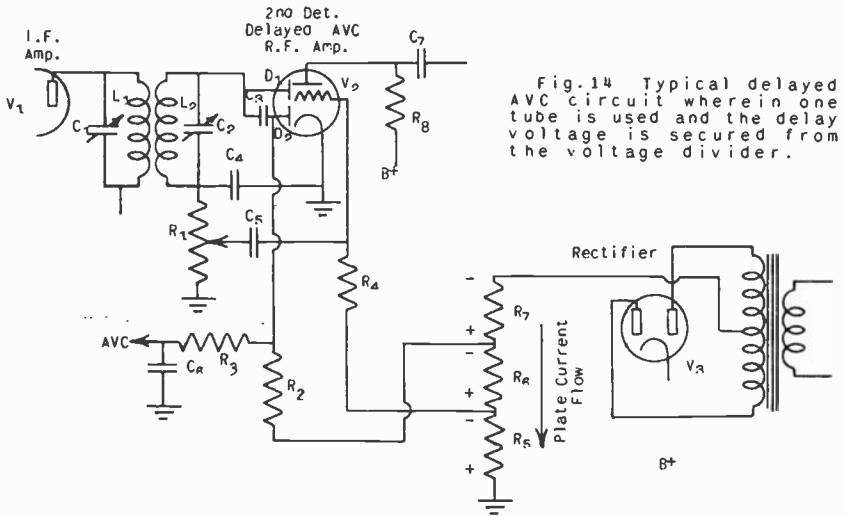

The delayed AVC voltage is secured through the rectifying action of diode plate D2. The coupling condenser C3 is to isolate the two diode circuits and to permit application of the I.F. voltage developed across L2C2 to the diode plate D2. This diode plate is biased negative with respect to the cathode by an amount equal to the voltage drop across R6 and R5. It is not until the signal voltage developed between D2 and cathode is sufficient in amplitude to overcome the potential across R6 and R5 that rectified diode current will flow through the AVC load resistor R2. Signals sufficient in strength to overcome the delay voltage and cause a diode current to pass through R2, will develop an average voltage across R2 which is in direct proportion to the average strength of the I.F. voltage across L2C2. The DC component of the voltage across R2 is fed through the filter R3C6 to the grid circuits of the AVC controlled tubes in the receiver, thus changing their sensitivity.

The bias voltage for the grid of the triode section of the duplex-diode triode V2 is secured across resistor R5. These three resistors, R5, R6, and R7, are connected between chassis ground and B- (center tap of the high voltage winding); hence, the plate

current and bleeder current drawn by all the tubes and bleeder resistances in the set pass through these three resistors. The direction of the current flow through these resistors is such as to develop a potential across each with the bottom end positive and the top end negative. These potentials (negative with respect to ground) may then be used for grid bias on the triode section of V2 and to serve as the delay potential for the AVC section of V2.

The circuit shown in Fig. 14 is typical of a number of commercial broadcast receivers. It will be noticed that the potential necessary for delaying the AVC is secured from the voltage divider rather than by the use of a battery as in Fig. 13. Another advantage of Fig. 14 over Fig. 13 is the fact that the multi-purpose tube eliminates the necessity of using several diodes to perform the various operations. Duplex-diode pentode tubes, such as the 6B7, may be used in circuits of this kind and greater audio voltage output will be produced, due to the higher gain of the pentode section.

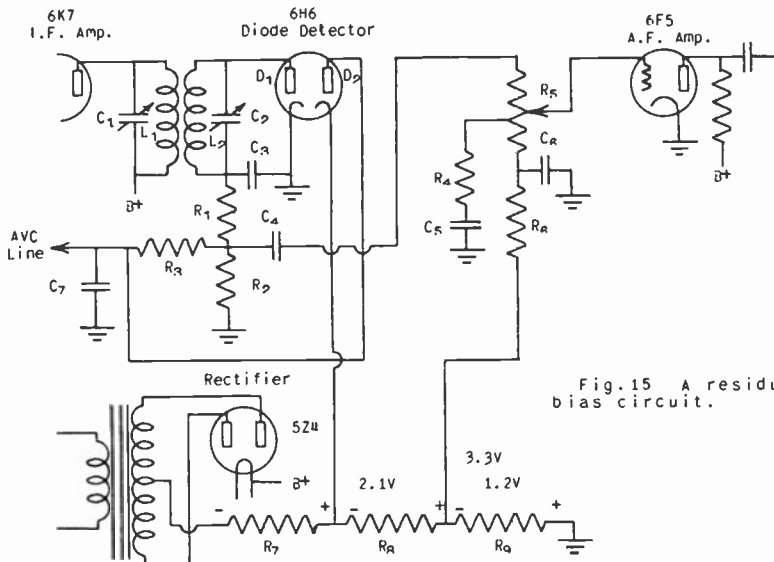

Fig. 15 A residual bias circuit.

Another AVC circuit worthy of mention is that employing a 6H6 duo-diode, all metal tube. With this tube, it is possible to secure diode detection, delayed AVC, and the residual (no-signal) bias for the controlled tubes. The diagram in Fig. 15 shows the circuit connections necessary to obtain these results.

All the amplifying tubes in a receiver that are controlled by the AVC voltage must be supplied with a minimum bias so as to limit the plate current when no signal is being received and to prevent distortion when receiving weak signals. This minimum bias is sometimes called the "residual bias". Ordinarily, residual

bias is secured with a cathode resistor or from the voltage divider. The use of the 6H6 duo-diode connected as shown in Fig. 15 eliminates the necessity of supplying the residual bias in this manner, because it is developed in one of the diode sections of the 6H6 and delivered through the AVC feedline to the grids when no signal is being received. The application of a signal voltage to the diode detector circuit of sufficient strength to exceed the residual bias develops an AVC voltage which is then fed to the grid circuits of the controlled tubes through the AVC line.

To explain how this action occurs, let us draw the essential parts of the circuit in a slightly different manner so as to reveal the operation more clearly. Fig. 16 is an exact duplicate of the portion of Fig. 15 that is a part of the AVC and residual bias circuit. The two diode sections of the 6H6 are shown as separate tubes; however, they are numbered the same in Fig. 16 as in Fig. 15. The purpose of separating the diode sections in this manner is to facilitate a clearer conception of the action which occurs. Let us first assume that there is no input signal voltage fed to the resonant circuit L2C2. Under this condition, there will be no flow of diode current through D1. From the voltage divider in the receiver, a potential of 3.3 volts is developed across R8 and R9. It will be noted that R8 and R9 in Fig. 16 are connected in exactly the same manner as in Fig. 15. The size of these two resistors are so chosen, relative to the total current drawn from the 5Z4 rectifier, that a voltage of 3.3 volts is developed across them. The voltage across R9 (1.2 volts) serves as the grid bias potential for the 6F5 first audio amplifier.

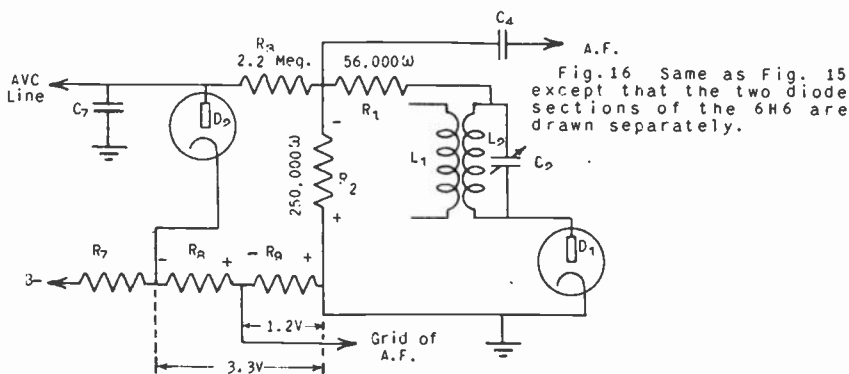

The total voltage of 3.3 volts across R8 and R9 supplies the residual bias to the grids of the controlled tubes. The manner in which this voltage is supplied to the AVC line can be seen quite clearly by reference to Fig. 16. Due to the direction of the voltage developed across R8 and R9, the plate of the diode D2 is made positive with respect to its cathode; hence, a current will flow from the cathode to the plate, through resistance R3, through R2, then back through R9 and R8 to the cathode. Current flowing

in this direction develops a voltage across  $R_3$  (diode load resistance) of approximately 3 volts. Nearly all the voltage will be dropped across  $R_3$  rather than the diode (from cathode to plate) or  $R_2$ , because  $R_3$  is very large in comparison with these other two resistances. The DC potential of 3 volts developed across  $R_3$  is then fed through the AVC line to the grids of the controlled tubes. These conditions exist when no signal is being received. Notice that the controlled tubes are biased properly under "no-signal" conditions.

When a modulated signal is received, I.F. voltages will be developed across L2C2 and applied to diode plate D1. When the plate of D1 is made positive with respect to its cathode, a rectified diode current passes through the load resistance  $R_2$  and voltages are developed across it. There will also be a voltage across  $R_1$ ; however, due to the smaller size of  $R_1$ , it is of no consequence insofar as the AVC action is concerned. The voltage across  $R_2$  is in such a direction as to make the top negative and the bottom positive. This voltage bucks against that across  $R_8$  and  $R_9$ ; hence, the plate of D2 is made less positive with respect to its cathode and a lower current passes through the diode load resistance  $R_3$ . The negative voltage supplied to the grids of the controlled tubes, however, is still 3 volts, because as the voltage decreases across  $R_3$ , it increases across  $R_2$ , and they are in such a direction as to add to each other. As soon as the incoming signal is sufficient in amplitude to produce a voltage across  $R_2$  equal to or exceeding 3.3 volts, the plate of D2 will be made negative with respect to its cathode; hence, this portion of the circuit will no longer be conductive, and the AVC voltage developed across  $R_2$  will increase the negative bias on the grids of controlled tubes in the normal AVC manner. Since the diode D2 becomes non-conductive when the potential across  $R_2$  exceeds 3.3 volts, in effect this section of the 6H6 diode is removed from the circuit and the DC component of the voltage developed across  $R_2$  (AVC voltage) is fed through the filter  $R_3C_7$  to the grids of the controlled tubes.

When the signal input to the tuned circuit L2C2 is reduced to zero, a rectified current no longer passes through the diode D1, and the voltage across  $R_2$  drops to zero. Immediately, the plate of D2 is made 3.3 volts positive with respect to its cathode; a current flows through  $R_3$ , and a residual (minimum) bias is produced on the grids of the controlled tubes. The residual bias voltage across  $R_3$  also serves as a delay voltage for the AVC system. This is advantageous in comparison with a conventional delayed AVC circuit, because it is desirable to remove the delay voltage after the input signal exceeds the threshold voltage. A delayed AVC circuit tends to produce amplitude distortion of received signals which employ a high percentage modulation. By removing the delay voltage for strong signal inputs, this distortion is minimized. The delay voltage is removed with the residual bias when the potential across  $R_2$  exceeds 3.3 volts.

A very interesting type of AVC circuit which is basically different from any we have studied previously is shown in Fig. 17.

Although this is a delayed AVC system, it also involves a DC amplifier in the AVC circuit. If you refer to Fig. 17, you will note that the signal is coupled to the diode D1 of the 6B7 through the small coupling condenser C1. The capacity of this condenser is 25 mmfd. The diode D1 in the schematic, functions as a straight rectifier, and its load resistor R1 is returned directly to the cathode, hence there is no delay voltage in this circuit. The rectified voltage produced across R1 is fed to the grid of the pentode section of the 6B7 through the resistive capacitive filter composed of R2 and C2. Inasmuch as the screen and plate of the pentode portion are tied together and connected

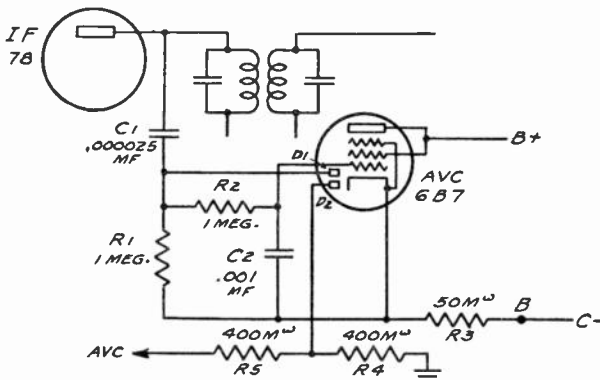

Fig. 17 Schematic of DAVC circuit employing a DC amplifier.

to the positive side of the power supply, this part of the tube functions as a triode rather than as a pentode. The cathode of the tube is connected to the center tap of the high voltage winding through a 50,000 ohm resistor. Since the speaker field is in the negative leg of the power supply (not shown in the figure) it follows that the "B" end of R3 is at all times negative with respect to ground. The plate of the second diode D2 is connected to ground through the 400,000 ohm resistor R4 and at the same time the AVC voltage is taken off through another 400,000 ohm filter resistor R5.

Let us now analyze the action which takes place under varying conditions of input signal. When the incoming signal is very small, the voltage impressed across D1 is also small, with the result that only a small amount of negative voltage is fed over to the grid of the pentode section through R2. This small amount of bias results in a comparatively high value of plate current flow through the cathode resistor R3 and the circuit constants are so chosen that the voltage at the cathode is positive under these conditions of large plate current. Since the diode plate D2 is grounded through R4, you can readily see that no plate current can flow in this diode circuit through R4 so that there is no voltage drop across R4. This, in turn, means that there will be no con-

trol voltage fed over to the controlled tubes through R5 under these conditions of low signal input.

We see, then, that under conditions of little or no input signal, the diode D2 does not draw current. However, as the input signal to the receiver is increased, the following changes in the circuit conditions take place. First of all, the increased signal applied to D1 results in an increased value of rectified voltage fed across R1, which in turn, means that the bias of the pentode section is increased. The increased bias on the control grid of the pentode (used as a triode, of course), acts to decrease the value of plate current, and this, in turn, decreases the voltage drop across R3. We have previously observed that the greater the value of plate current through R3, the more positive will the cathode of the 6B7 become. It thus follows that the effect of the decreased value of plate current under conditions of comparatively large values of input signal is to make the cathode less positive. We see, then, that larger values of input signal result in smaller values of plate current which make the cathode more negative. Thus, as the signal input is increased, starting from a small value, the potential or voltage at the cathode also decreases from a positive voltage with respect to ground, and finally a point is reached where the voltage at the cathode becomes zero. This is the critical value of signal input at which the diode D2 begins to function. For input signals beyond this threshold value, the cathode of the tube becomes negative so that increased values of current flow through the resistor R4. Furthermore, the direction of this current is such that the ungrounded end of R4 becomes negative. It is this negative voltage developed across R4, which serves as the AVC control voltage, and which is distributed to the several controlled tubes through the filter resistor R5.

The outstanding characteristic of AVC circuits which affects servicing is the high resistances involved. Resistances from 100,000 ohms to over 1 megohm enter into the circuits of the AVC system. In servicing these systems, it is necessary that the instruments used be capable of easily and accurately measuring these high resistances. Also, due to the high resistances involved, the leakage of filter condensers can easily upset the whole AVC system, even when the leakage resistance is as great as several megohms.

5. NOISE SUPPRESSION CIRCUITS. A receiver equipped with AVC is in its most sensitive condition when no signal is being received, and if the volume control is advanced, excessive noise is certain to be amplified through the high gain stages of the receiver and reproduced with loud volume from the speaker. This is very undesirable, and is especially noticeable when tuning from one station to another. The absence of an input signal between stations permits the sensitivity and noise to be at a maximum. To correct this annoying condition, special circuits have been developed that are capable of preventing the passage of any signal to the speaker unless it is above a predetermined minimum value.

Such circuits are called "noise suppression", "QAVC" (quiet automatic volume control), or "squelch" circuits.

Perhaps the simplest type of quiet AVC to understand is the type which depends for its action upon the blocking of the second detector whenever the input signal falls below a pre-established value. This system is used in a considerable number of receivers.

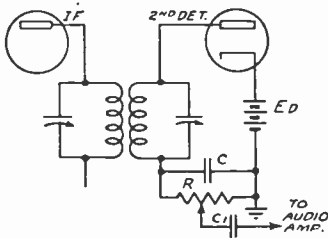

Fig. 18 Basic circuit of a QAVC system employing a blocked second detector.

The basic circuit, which is characteristic of quiet AVC systems of the blocked second detector type, is shown in Fig. 18. The circuit as shown, has been stripped of all its non-essentials, and for this reason, appears to contain but few components. However, you will observe that the circuit is similar in character to that which has been illustrated as being typical of a delayed AVC circuit. The signal from the last I.F. stage is fed to the second detector, and a voltage, designated as  $E_D$ , is inserted in series with the cathode. The effect of such a voltage in series with a rectifier circuit, with the cathode made positive with respect to ground, has been previously discussed. However, in this case, the purpose of the delay voltage is contrary to that intended in a delayed AVC system. Here, the purpose of the voltage is to prevent rectification of signals until the input signal voltage exceeds the value of this delay voltage. You will recall that in connection with delayed AVC, the function of delay voltage was to prevent the development of an AVC control voltage until the received signal was greater than a certain predetermined value. Rectification, on the other hand, was accomplished by another tube in the circuit so that an output signal was at all times available. In this case, however, there being no rectification until the input signal is greater than a predetermined value, the receiver is quiet, or silent, until a signal of proper value is tuned in. The magnitude of the required signal is slightly greater than that of the delay voltage. The value of the voltage  $E_D$  is, therefore, the factor that permits the choice of the minimum signal level at which the receiver will operate.

In view of the usual importance of sensitivity, you will be tempted to say that such a circuit arrangement will tend to lower the sensitivity of a receiver since it becomes impossible to obtain any output until the input signal reaches an appreciably high value so as to overcome the delay voltage. This is correct, except for one fact: namely, that the design of the usual receiver is such that the delay action is not experienced with the



normal run of signals---even weak signals, because the amplification available between the antenna the the second detector is such as to provide a reasonably strong input into the second detector, and thereby overcome the delay voltage. The delay voltage is made small enough so that only those signals too weak to give satisfactory reception will be blocked. Thus, the quiet AVC system provides freedom from noise as the station selector is rotated.

Another type of quiet AVC is one which depends for its action upon the blocking of the audio amplifier rather than the second detector whenever the input signal falls below a certain value. In general, circuits of this type depend upon the application of a control voltage to reduce the voltage amplification in the first audio stage to a point where no signal reaches the speaker. The element to which this control voltage is applied may be either the plate, the screen grid, the suppressor grid, or the control grid, depending upon the circuit design.

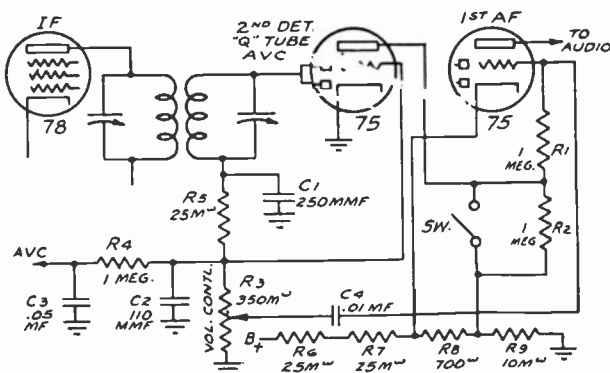

Fig. 19 QAVC circuit employing a blocked A.F. amplifier.

The circuit shown in Fig. 19 is representative of those in which the A.F. amplifier is blocked. You will note that the diode section of the first 75 tube is used as the second detector and also as the AVC tube. The AVC voltage is fed to the controlled tubes through the filter consisting of R4 and C3, while the negative voltage, which is applied to the grid of the triode section of the 75, is taken directly from the high side of the second detector load, R3. The plate of the triode section, which serves as the "Q" tube, is connected to a positive point on the voltage divider through a 1 megohm resistor, R2. The diode section of the second 75 tube is not used.

The triode section of this second tube is the first audio stage. Its cathode is connected to the voltage divider at the junction of R7 and R8. Since the grid of this tube is connected to the junction of R8 and R9, it is clear that an initial bias is placed on the first audio tube equal to the voltage drop along R8.

To explain the noise suppression action, it is necessary to examine the bias on the first A.F. tube under varying conditions of input signal. When the input signal is high, the voltage developed across the detector load ( $R_3$ ) will also be high. Furthermore, with this high negative voltage applied to the grid of the first 75 tube, the plate current of this "Q" tube will be very small. This, in turn, means that there will be practically no voltage drop across  $R_2$ , with the result that the bias on the first A.F. tube is not increased, but is equal to the normal value established by the voltage drop across  $R_8$ .

As the input falls to weak values, the bias on the "Q" tube is decreased so that the plate current of the "Q" tube increases. This, in turn, results in an appreciable voltage drop across the 1 megohm resistor  $R_2$ , and the bias on the first A.F. tube will be increased to the extent of the drop along  $R_2$ . Since the 75 first audio tube is of the high- $\mu$  type, the circuit design is such that the increased bias is sufficient to cut off the plate current of the first A.F. tube and to reduce the amplification to zero. This naturally blocks the receiver and produces an effective noise suppression action.

With the "Q" switch closed, so as to short  $R_2$ , no additional bias is impressed upon the grid of the first A.F. tube under conditions of low input signal, so that the "Q" circuit is inoperative, and the receiver then functions at maximum sensitivity with no noise suppression action.

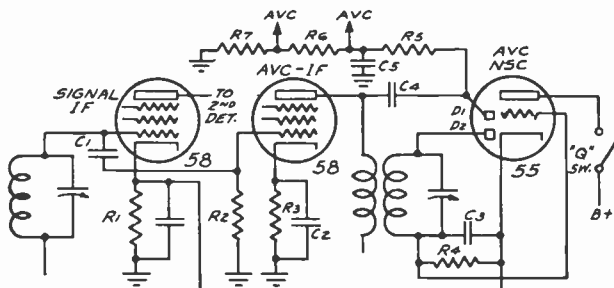

Fig. 20 Noise suppression circuit operating on blocked I.F. amplifier principle.

A third type of noise suppression is one which depends for its operation upon the blocking of the I.F. amplifier during those periods when the input signal falls below a certain value. The circuit shown in Fig. 20 is a partial schematic of such a system, showing the essential parts of the AVC and noise suppression circuit. If you examine the schematic, you will note that there are two I.F. amplifier stages. One amplifies the signal and connects to the second detector; the other amplifies the voltage which feeds the AVC rectifier.

Each of the two diodes in the type 55 tube is used for a separate purpose. The diode designated as  $D_1$  is the AVC recti-

fier, and receives its voltage from the primary winding through the small coupling condenser C4. The AVC voltage is fed to the controlled tubes from the voltage divider composed of R5, R6, and R7. The second diode, D2, is connected to the secondary winding of the I.F. transformer, and the load for this diode is the resistor R4, which is by-passed for I.F. by the condenser C3. You should observe that this resistor is returned directly to the cathode; whereas, the AVC load is returned to ground. The cathode of the 55 is not grounded, but is connected to the cathode of the 58. Thus, it will be positive with respect to ground by the drop across R1. Therefore, the AVC control voltage will be delayed, the drop across R1 constituting the delay voltage. The plate of the triode section of the 55 is connected to B plus through the switch designated as the "Q" switch.

When no signal voltage is impressed on the receiver, no voltage is produced across R4, the load of the noise suppression diode D2. Since the triode section receives its bias from the voltage across R4, it follows that under conditions of zero or very small input signal, the triode section operates at zero or very low bias. With this condition, the plate current of the triode is very large; approximately 10 ma. Since this plate current flows through the cathode resistor R1, which is common to both the signal channel I.F. amplifier and AVC tube, this 10 ma. plate current will develop a positive voltage on the cathode of the I.F. tube. Since the resistance of R1 is 4500 ohms, the voltage drop across R1 will be 45 volts, and this voltage is sufficient to reduce the amplification of the I.F. stage to a point where no signal voltage will reach the second detector.

With a larger signal input, the increased bias, which is developed across R4, acts to reduce the plate current of the triode section, and hence to reduce the voltage across R1, and the bias on the signal channel I.F. stage. In this way, the sensitivity of the I.F. amplifier is restored under conditions of larger input signal and the receiver functions in the usual manner. There will, of course, be no AVC voltage developed until the signal applied to D1 exceeds the delay voltage.

6. MISCELLANEOUS REQUIREMENTS OF ALL-WAVE RECEIVERS. Having covered the subjects of AVC and noise suppression circuits, we can look into another feature of all-wave receivers. As a rule, the first detector circuit of modern all-wave receivers differs from that of broadcast receivers, due to the higher frequencies found in most of the bands. In pentagrid converters, even though the plate of the oscillator section is shielded from the R.F. signal grid by a grounded electrode, a certain amount of capacity exists between these elements. This capacity is not high enough to cause trouble at broadcast frequencies; however, at the higher frequencies a strong R.F. signal can induce a voltage on the oscillator plate causing a shift in the frequency of the oscillator. Such a shift in frequency causes the set to be out of alignment, and a consequent weakening of the signal. There is also a possibility of the oscillator signal generated at the plate of the oscillator

section feeding directly into the pentode detector section. The higher the frequency of operation, the greater will be the tendency for this interaction to occur.

In modern receivers, a pentagrid mixer tube such as the 6L7, helps to eliminate the first detector-oscillator difficulties. This tube has two control grids, and is always used with a separate oscillator tube. Fig. 21 shows a block diagram of how this tube is employed. The R.F. signal is applied to one control grid, and the oscillator signal, generated in a separate circuit, is

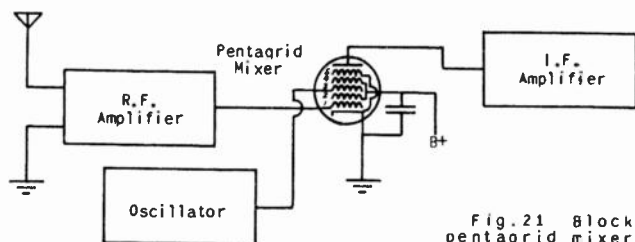

Fig. 21 Block diagram of pentagrid mixer circuit.

applied to the other control grid. The variations in the plate current will be due to the combination of the R.F. and oscillator signals. Referring to Fig. 21, the R.F. signal is applied to grid #1, which is a remote cutoff grid, and thus, is suitable for control by an AVC voltage. The oscillator signal is fed to grid #3, a sharp cutoff grid, which gives a large change in plate current for a small amount of oscillator voltage. Grid #2 and grid #4 are tied together within the tube; they serve to accelerate the electron stream and to shield grid #3 electrostatically from the other electrodes. Grid #5 functions similar to the suppressor grid in a pentode. Thus, the interelectrode capacity between the signal grid #1, and the oscillator grid #3 is reduced to a very small value; and, the frequency of the oscillator cannot change materially, due to voltage interactions, because the oscillator signal is generated in a separate tube. Grid #3 is merely a means of coupling the oscillator voltage to the mixer or first detector tube. This method of generating the intermediate frequency also has the advantage of producing an increased output voltage at the higher frequencies; another difficulty encountered when a conventional pentagrid converter tube is used. The 6L7 tube (or its equivalent) is used in the mixer stage of a large majority of the present-day all-wave superheterodyne receivers.

In the design of a modern all-wave superheterodyne, the separate oscillator is also a vital point. On the high-frequency bands, tuning is very sharp, and a small drift in the oscillator will cause the signal to disappear. For this reason, the maintenance of frequency stability in the oscillator circuit cannot be over-emphasized. It is also very important that the strength of the output voltage remain as constant as possible. For the reception of weak, high-frequency signals, the strength of the oscillator's output voltage should be quite high in order to maintain a

reasonably strong I.F. signal in the plate circuit. The intensity of the intermediate frequency voltage depends to a large extent upon the strength of the oscillator's output, and since most of the high-frequency signals encountered throughout the short-wave bands are relatively weak, the oscillator's output voltage must be sufficiently high to maintain satisfactory reception.

The intermediate frequency amplifier in an all-wave receiver differs somewhat from that employed in a standard broadcast set. The circuit arrangement generally appears about the same; however, the electrical characteristics of the circuit are considerably different. The intermediate frequencies of all-wave receivers are high, generally 456 kc. or 465 kc. As discussed in Lesson 27 of Unit 1, the use of a high intermediate frequency is advantageous from the standpoint of preventing image frequency interference. On the high-frequency bands covered by all-wave receivers, the image frequencies are much closer together (in percentage) than on the standard broadcast band; hence, if a high intermediate frequency is not used, the separation of desired and undesired stations is rather difficult. Whereas, an I.F. of 175 kc. to 260 kc. might be very satisfactory for reception throughout the standard broadcast band, it would not do for ultra-high frequency reception, because the image and the desired signal would be so close together that it would be virtually impossible to make a dial movement small enough to separate them.

The I.F. transformers in modern all-wave superheterodynes are quite different in design from those used a few years back, even though their external appearance is practically the same. Iron core I.F. transformers are very popular, and in several well-known receivers, the coupling between the primary and secondary windings (and sometimes the inductance of each winding) is made variable. These highly efficient transformers have been found beneficial in increasing the sensitivity of the receiver; a fact which is quite essential for satisfactory reception of the weak, high-frequency signals. By raising the sensitivity in this manner, rather than employing additional tubes and amplifying stages, the sensitivity of the receiver may be increased to the desired value without a corresponding increase in the noise level.

In all-wave receivers, it is quite important that the AVC circuit be properly designed. AVC is essential for short-wave reception, primarily to compensate for the fading which occurs at these frequencies. Since nearly all of the received signals are rather weak, the AVC is not for the purpose of preventing an overload on any of the stages. Fading is very common throughout the short-wave bands. If the threshold voltage of the AVC circuit is sufficiently low, the effect of signal fading is greatly reduced; however, if the strength of the incoming signal is below the threshold voltage, there will be no compensation as the signal fades. In this respect, an amplified-delayed AVC circuit is quite beneficial. In an amplified-delayed AVC system, it is possible to maintain a low threshold voltage and still obtain a flat AVC characteristic throughout the range of stronger input

signals. If only a delayed AVC circuit is employed, the threshold voltage is generally established at such a high value that the AVC circuit does not function during the reception of most short-wave signals. On the other hand, if only a simple AVC circuit is used, the sensitivity of the set is greatly reduced at weak signal inputs, so the AVC circuit is more detrimental than beneficial.

7. AUTOMATIC FREQUENCY CONTROL. Within recent years, the radio public has enjoyed true single-control tuning. The precarious adjustments of the old regenerative tuners and the tedious tuning of individual stages in the old TRF receivers has become almost ancient history. The first single-control receivers, you will recall, made no attempt to graduate the indicator in kilocycles. They were also very poor in selectivity, since the individual stages were necessarily broad in order to allow them to be ganged on one control. With succeeding years, the receivers became more selective, and it was possible to calibrate the dial and receive a signal at approximately the correct point on the dial. However, the increase in selectivity made correct tuning a very critical adjustment, and various tuning indication devices made their appearance. These devices were helpful, but it very frequently happened that a receiver was incorrectly tuned in spite of the facilities provided. Under these conditions, the audio reproduction was distorted and, in many cases, the receiver came into disfavor when the operator was really at fault.

Automatic frequency control, or AFC, is a system which will automatically and instantly correct any reasonable error which an operator may make in tuning in a signal. Proper tuning is, of course, necessary for good audio reproduction.

The action of the device is such that if the AFC is not in operation and a signal is tuned in so far off resonance as to be badly distorted, and the AFC is then switched on, the distortion will immediately disappear, indicating that the receiver has been brought into perfect tune automatically. Or, if the receiver is tuned with the AFC system in operation, the action will be such that as the point is approached on the dial where a particular signal is ordinarily received, the signal will be snapped into perfect tune and remain so as the dial indicator is moved on past the point where the station is ordinarily received. When the tuning has been moved a sufficient distance off the resonant point, the AFC circuit is no longer able to correct the error, and the receiver is off-tune in spite of the AFC. However, if there happens to be another strong signal near the frequency to which the indicator has been moved, away from the desired signal, at some critical point the receiver will jump from one signal to the other. Automatic frequency control is entirely electrical and is accomplished without any manual or mechanical movement of the tuning control or condenser gang beyond the approximate setting by the operator.

At the middle of the broadcast band, this device will pull in a signal of 5,000 microvolts from 7 kc. off resonance to within

500 cycles of resonance. Even a skillful operator is not ordinarily able to tune a receiver with more accuracy than 500 cycles. A stronger signal will be pulled in from a greater distance than 7 kc. A 5,000 microvolt signal will be pulled in from 4 kc. off resonance to within less than 300 cycles. This is more accurate than human hands and ears can do it.

It would be easily possible to increase the sensitivity of this device and cause the AFC to pull in the signal from a greater frequency off resonance as well as hold on to the signal for a greater distance off resonance. However, if the sensitivity were increased in this manner, there is danger that the receiver would remain in tune with the original signal even though the tuning control were moved to another point in anticipation of receiving some other desired signal fairly close in frequency.

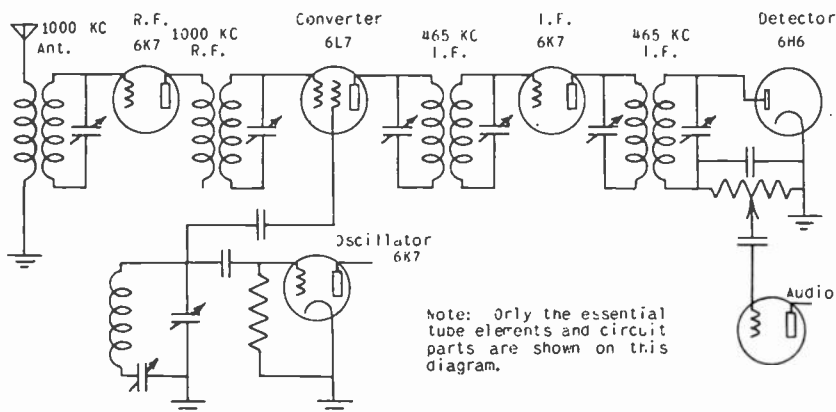

	Incoming Signal	Oscillator Freq.	Resultant Freq.
Correctly Tuned	1000 KC	1465	465
Incorrectly Tuned	1000 KC	1468	468
Incorrectly Tuned	1000 KC	1462	462

Fig. 22 Conventional superheterodyne receiver circuit.

First, let us see what the conditions are when an ordinary receiver is tuned; one which does not incorporate AFC. Fig. 22 is intended to represent the conventional superheterodyne receiver. Three possible conditions of tuning are shown. When the local oscillator is producing a signal exactly 465 kc. higher than the incoming signal, the receiver is correctly tuned. For instance, if the incoming signal is 1000 kc. and the tuning control is set so that the frequency of the local oscillator is 1465 kc., then the I.F. signal is 465 kc., which is the frequency to which the I.F. amplifier is peaked. Under these conditions, the signal is amplified and passed through to the detector without distortion. However, if the tuning control is incorrectly adjusted, the local oscillator will then be either more or less than 465 kc., and

since the incoming frequency is the same as before, the resultant I.F. signal produced will be either more or less than 465 kc., and, while it will be amplified and passed through the I.F. system, distortion will be produced.

We will now proceed to determine the cause and severity of this distortion which is caused by improper tuning. Fig. 23 shows two views of the well-known selectivity curve of a tuned system. You see it every time you use an oscilloscope for alignment purposes. The curve shown is for a typical I.F. amplifier, taken from the grid of the converter tube to the diode load. Such a selectivity curve is in reality simply an indication of the percentage gain for frequencies either side of resonance. The peak represents 100% gain at whatever frequency it may occur, and for frequencies close to resonance, the gain approaches 100%. At a frequency 10 kc. off resonance, the gain may be down to .5% or less. This would be necessary in order to prevent interference from a carrier 10 kc. or one channel away. In order for a signal to be amplified by such a series of circuits without distortion, the I.F. carrier must be very nearly 465 kc. as stated.

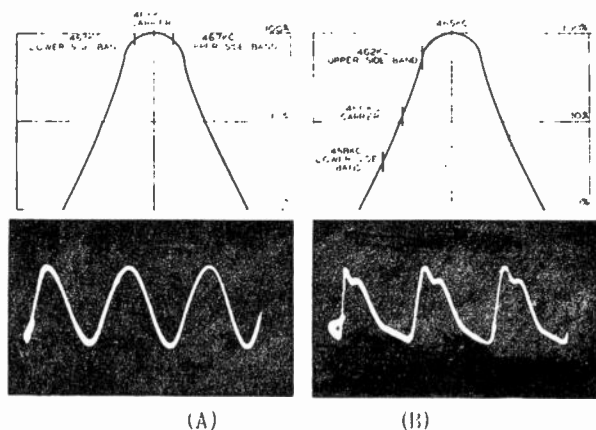

Fig. 23 (A) Graph and selectivity curve of I.F. amplifier when it is in resonance. (B) Graph and selectivity curve of I.F. amplifier when 5 kc. from resonance.

Remember that when the carrier is modulated, the sideband frequencies extend several kc. above and below the carrier and that they have a frequency more or less than the carrier by an amount equal to the frequency of the modulation. For instance, if the modulation is 2,000 cycles; then the sidebands present will be 465 kc. less 2,000 cycles, or 463 kc.; and 465 kc. plus 2,000 cycles, or 467 kc.; and we would really have three separate and distinct frequencies; 465 kc., 463 kc., and 467 kc. From a glance at the selectivity curve, we see that if the receiver is correctly tuned, the carrier of 465 kc. falls right at the peak of the curve, and this will be amplified a maximum amount. However, the



sidebands will be amplified somewhat less, since the gain is down a small percentage at these frequencies; that is, 463 kc. and 467 kc. However, since the curve is symmetrical, both sidebands will be attenuated equally, and the only result will be a slight reduction in the response to a modulation frequency of 2,000 cycles, no distortion being produced.

The oscilloscope picture shown at A, Fig. 23, was taken under the conditions just mentioned; that is, a carrier of 465 kc., 80% modulated with a 2,000 cycle steady signal. The oscilloscope was connected across the diode load resistor. Note that the resultant audio signal is a sine wave, indicating that no distortion took place as the original modulated signal passed through the I.F. amplifier system. For a modulation frequency of 4,000 cycles, the sidebands would be 461 kc. and 469 kc.; and we see that these frequencies are down by a considerable percentage. This simply means that the higher the modulation frequency, the more it will be attenuated by a sharply tuned and selective circuit or series of circuits. This effect of cutting the highs in a selective receiver is well known and easily evident unless some compensation of the highs is employed in the audio system. However, so long as the attenuation of both sidebands is equal, no distortion will result.

Referring to curve B, which is this same selectivity curve, let us make the carrier frequency 460 kc. instead of 465 kc., and modulate it with a frequency of 2,000 cycles as before. Since the center of the I.F. curve is 465 kc. as before, the receiver is mistuned. Note now, that the upper sideband is amplified more than the carrier; and that the lower sideband is amplified less than the carrier. This will result in distortion, since it has been pointed out that the two sidebands must be equal in amplitude to avoid distortion of the envelope. The oscilloscope picture shows that this is true. It was taken across the diode load as before, and under the conditions illustrated above; that is, a 460 kc. carrier, 80% modulated with a 2,000 cycle steady signal. Note that the waveform has become very badly distorted, as can be readily perceived by a listening test.

Obviously, what we would like to do at all times is to keep the carrier or I.F. frequency at exactly 465 kc., which is the center of the I.F. selectivity characteristic, and thus maintain the correct relation between sidebands and carrier.

These pictures are a fine illustration of how effective this AFC circuit actually is. The distorted waveform was obtained with the receiver mistuned as explained. Then, with no other changes whatever, the AFC switch was thrown and the resulting sine wave obtained, indicating that the mistuning had been completely corrected. This action is accomplished by changing the frequency of the local oscillator so that the I.F. frequency is maintained at 465 kc. so long as the tuning control is set within a reasonable distance of the correct point on the dial. Even though the tuning control be moved back and forth a considerable distance, the oscillator will remain at the correct frequency to produce an I.F. carrier of 465 kc., and the receiver is correctly tuned.

At this time, let us proceed to learn just how AFC functions. It will be explained briefly from Fig. 24, just what action takes place, and with succeeding sketches, the individual parts of the circuit will be taken up in detail.

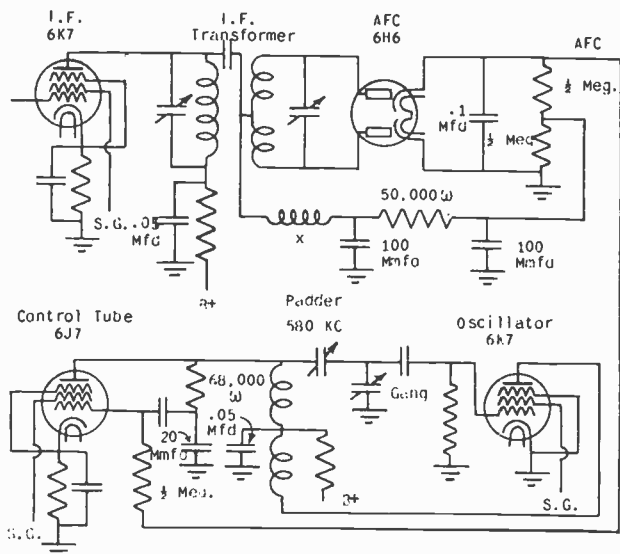

Fig. 24 Complete circuit diagram of AFC system.

Fig. 24 is a simplified schematic of the whole AFC system. Here is the oscillator circuit, with grid coil tuned as usual by a section of the gang condenser. Connected across this tuned circuit is a tube which has an effect upon this tuned circuit; that is, upon the frequency of the oscillations. The effect of this tube is controlled by varying its control grid bias to cause either an increase or decrease in oscillator frequency. The voltage for controlling this tube is developed by special circuit arrangements of the last I.F. stage and second detector. In some respects, this circuit is similar to the usual AVC system, but the AFC voltage used to control the control tube is either positive or negative with respect to ground, depending upon to which side of resonance the receiver is tuned.

Now we will proceed to take up each part of the circuit in greater detail. It is suggested that each step be carefully followed and understood, without any attempt to think ahead to the possible ultimate result. We have here a circuit which is new, is being used extensively, and is considerably more complicated than any AVC system.

Fig. 25 shows a perfectly conventional oscillator circuit such as you will find in a majority of superheterodynes on the market today. Of course, there are a number of variations, but

for the purposes of this discussion, we will consider this circuit only.

The frequency of oscillations in this circuit is determined by the value of the inductance and capacitance. The frequency of oscillations would be increased by making either the inductance or the capacity smaller; and, conversely, the frequency could be lowered by making the inductance or the capacity larger.

Fig. 25 Conventional oscillator circuit.

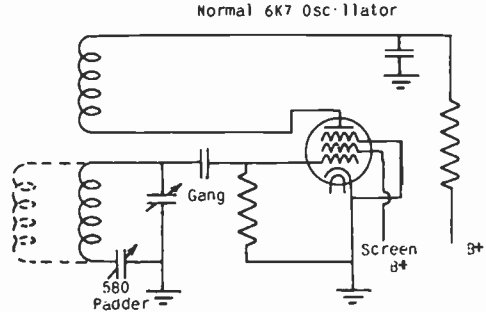

The inductance could easily consist of two coils in parallel with each other if we so desired, and the inductance would then be something less than either one of the parallel coils alone. Placing two coils in shunt with each other is similar to placing two resistors in parallel with each other; the combined impedance or resistance will always be less than the smaller one. Where one is much larger than the other, the total resistance or impedance will be practically equal to that of the smaller. So, then, if we used two coils in parallel with each other instead of a single coil, we could make the total inductance larger or smaller by making one of the coils larger or smaller. The smaller the total inductance becomes, the higher the frequency of oscillations, and the larger it becomes, the lower the frequency.

In our AFC circuit, in order to provide some means of either increasing or decreasing the oscillator frequency from its normal frequency without changing the gang capacitor setting, we are going to connect an apparent inductance across the oscillator coil and provide some means of making that apparent inductance either larger or smaller. In this case, the apparent inductance is going to be a vacuum tube. Just how a vacuum tube can be made to look like an inductance requires some explanation.

Let us first consider the properties of any inductance. If a circuit is arranged as shown in Fig. 26 with a real inductance across a voltage source in series with a switch, neither current nor voltage will be indicated until the switch is closed. However, when the switch is closed, an interesting thing happens; voltage appears across the inductance immediately, but the current increases slowly, and may not reach a maximum for several seconds, indicating that the current lags behind the voltage. If the battery is replaced by an AC generator and the alternating voltage

is applied in the same manner, when we provide some means of indicating both voltage and current, we will find that the current wave will lag behind the applied voltage wave by nearly one-quarter cycle or  $90^\circ$ . This is one of the properties of an inductance; whether connected across an AC source or a DC source, the current will always lag behind the voltage.

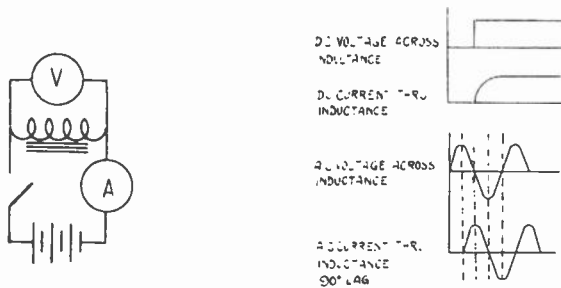

Fig. 26 Circuit to illustrate current lag through an inductance.

If we now make a special arrangement of a vacuum tube so that it will have this property of drawing a lagging current, we will have a device which will act like an inductance. If we place this device across the coil in the oscillator circuit, we will have essentially two inductances in parallel. Then, as we vary the apparent inductance of this tube, we will vary the total inductance in the circuit, and consequently the frequency of the oscillations.

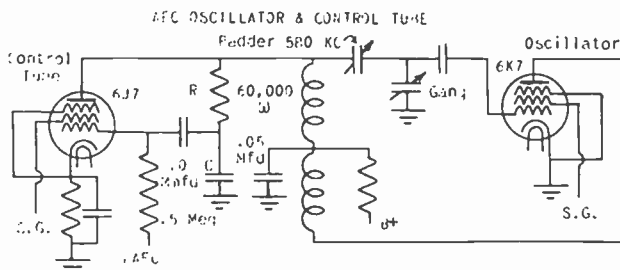

Fig. 27 Oscillator and control tube of AFC circuit.

Fig. 27 shows the oscillator with the control tube connected across it. Certain changes have been made in the oscillator circuit in order to allow the connection of the control tube. The plate feedback coil has been removed to the bottom end of the grid coil and connected to it. The 580 kc. padder has been moved to the top end of the coil and the comparatively large capacitor of .05 mfd. connected between the lower end of the coil and ground.

After the current lags, the voltage only until the current reaches maximum.

This isolates the oscillator coil so that plate voltage for the control tube as well as for the oscillator plate may be applied through the coil. The fact that the plate voltage is applied in this manner has no effect whatever upon the oscillatory circuit, the bottom end of the coil being at ground potential to R.F. the same as before, since the .05 mfd. capacitor is so large as to be practically a short-circuit to R.F. currents. Also, the gang capacitor is across the coil in series with the 580 kc. padder as before.

The control tube is in parallel with the oscillator coil. Although the DC plate supply of the control tube is constant, there is an R.F. voltage present across the grid coil, due to the fact that it is part of the oscillatory circuit, so that the control tube is working into an AC source.<sup>1</sup> Here, as in many tube circuits, we can forget about the DC and consider the AC circuit only. As stated before, it is necessary that the control tube cause a lagging current to flow through the grid coil in order for it to appear like an inductance. In accomplishing this action, the key to the whole situation is the excitation on the grid of the control tube.

First of all, let us consider what the effect would be of this control tube upon the oscillator circuit if there were no AC excitation of any kind on its grid. The control tube circuit would simply have a definite resistance or impedance from plate to ground. Obviously, this tube impedance is directly across the oscillator tank<sup>2</sup> and so would draw current from the tank circuit. However, since the tube simply acts like a resistance, it would be in-phase current, or in other words, the current drawn from the oscillator coil by the tube would neither lag nor lead the voltage causing it. Therefore, there would be no effect upon the frequency of the oscillator. Now if the grid bias were raised or lowered, the control tube would simply draw more or less current from the oscillator circuit, but this current would still be in phase and therefore there would still be no effect on the oscillator frequency. It is probable that in an actual demonstration of the statements just made, a slight change in frequency would result as the control tube was made to draw more or less current because of slight changes in the oscillator plate current as more or less power was drawn from the oscillator tank. These changes, however, would not be directly caused by the control tube.

However, if we excite the grid of the control tube with an AC voltage which has a lagging phase with respect to the voltage across the oscillator grid coil, we will get the desired effect of a lagging current flowing in the control tube plate circuit.

The network consisting of R and C constitutes an AC voltage divider across the oscillator coil and the voltage developed across C is applied to the grid of the control tube. This voltage applied to the grid is, however, out of phase with the voltage

<sup>1</sup>Note that these AC voltage variations in the plate circuit are across the oscillator tuned circuit and are not due to grid excitation on the control tube.

<sup>2</sup>The "oscillator tank" means the oscillator tuned circuit.

across the oscillator coil. Let us see why this is so. Although this voltage divider consists of both capacity and resistance, the resistance is considerably greater than the reactance of the capacitor and the network, therefore, looks nearly like a pure resistance to the source voltage which is across the oscillator grid coil. However, a phase difference between *current* and *voltage* always does exist when current is passed through either a capacity or an inductance. We found that in an inductance, the current lags behind the voltage; or to say the same thing in another way, the voltage *leads* the current. Conversely, then, the voltage *lags* the current in a capacity and so the voltage across the 20 mmfd. capacitor lags the current through it. However, we know this current is practically in phase with the source voltage across the oscillator coil and so the voltage across the capacitor lags the oscillator voltage.

Since this voltage is coupled to the grid of the control tube through a capacitor, this means that the grid is excited with an AC voltage which lags the AC voltage in its external plate circuit by nearly  $90^\circ$ . This lagging excitation on the grid of the control tube causes it to draw a lagging current from the oscillator grid coil across which it is connected.

By way of a brief explanation, refer to Fig. 28. The control tube may be replaced with a generator and resistance. The generator voltage will be equal to the amplification factor of the tube multiplied by the AC grid excitation and will be  $180^\circ$  out of phase

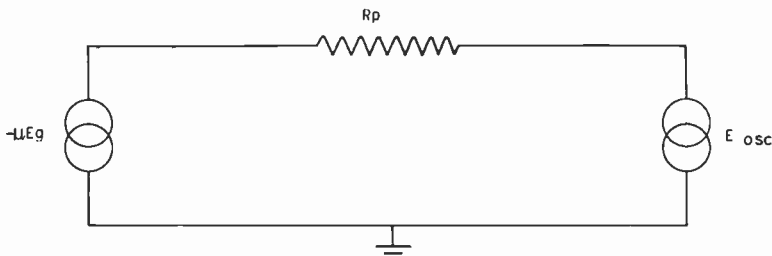

Fig. 28 Replacement generators to illustrate equivalent electrical circuit of the plate circuit of the control tube and the oscillator tank coil.

with the grid excitation. The resistance will be equal to the internal plate resistance of the tube. The voltage across the oscillator coil may also be replaced with an equivalent generator of the proper phase. This gives us two generators with a definite phase relation between them in series with a resistance. The exact phase of the current which will flow is dependent upon several factors; the degree of grid excitation, the amount of fixed grid bias, and the AC voltage across the oscillator coil. However, with this circuit arrangement, the current which flows will always be a lagging current.

Here then, we have the device we need; one which draws a lagging current from an AC potential across it and behaves, therefore, like an inductance.

We can also control the amount of lagging current the tube will draw by varying its grid bias. Consequently, we can vary the amount of its apparent inductance and shift the oscillator frequency either up or down.

As the control tube receives a more negative grid voltage, it draws less lagging current and accordingly looks like a larger inductance since a larger inductance would have a higher reactance, resulting in less current flow. A larger inductance would increase the total inductance in the circuit and lower the oscillator frequency. Conversely, as the control tube receives a less negative voltage, it draws more lagging current and so looks like a smaller inductance, since a smaller inductance would have less reactance, resulting in greater current flow. A smaller inductance would decrease the total inductance in the circuit and raise the oscillator frequency.

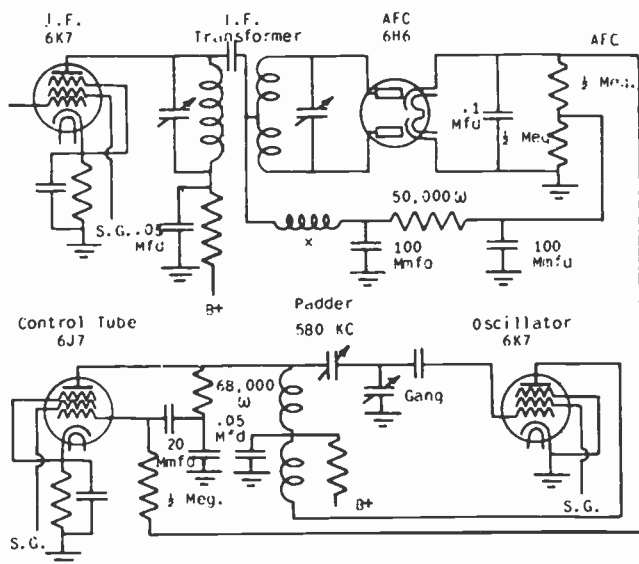

Fig. 29 Complete circuit diagram of AFC system.

As previously stated, this change in grid bias is furnished from another specialized circuit which delivers either a positive or negative voltage, depending upon which side of resonance the receiver is tuned. The voltage either adds to or subtracts from the initial bias obtained by use of a cathode resistor. Thus, as soon as an off-resonance condition exists in tuning, a control voltage is generated and the control tube functions to either increase or decrease the oscillator frequency to the point where the local oscillator beating against the incoming signal produces the correct I.F. frequency.

We now come to the AFC voltage generating circuit which controls the tube across the oscillator tank circuit. Referring to the top part of Fig. 29, this part of the circuit consists of a special I.F. transformer, tuned to the regular I.F. frequency of 465 kc.; two individual diode rectifier circuits and associated apparatus.

Briefly, the action of this circuit is as follows: At resonance, the AC voltages applied to each diode plate are equal. Each diode circuit has its individual load resistor, and when equal voltages are applied to the diode plates, the voltage developed across each individual diode load resistance is equal. These two load resistors are connected in series so that while as much as 50 volts DC may appear across each load resistance, the voltage measured across the opposite ends is zero. Since one end is grounded, the voltage from the top end to ground is zero. This is the condition existing at resonance.

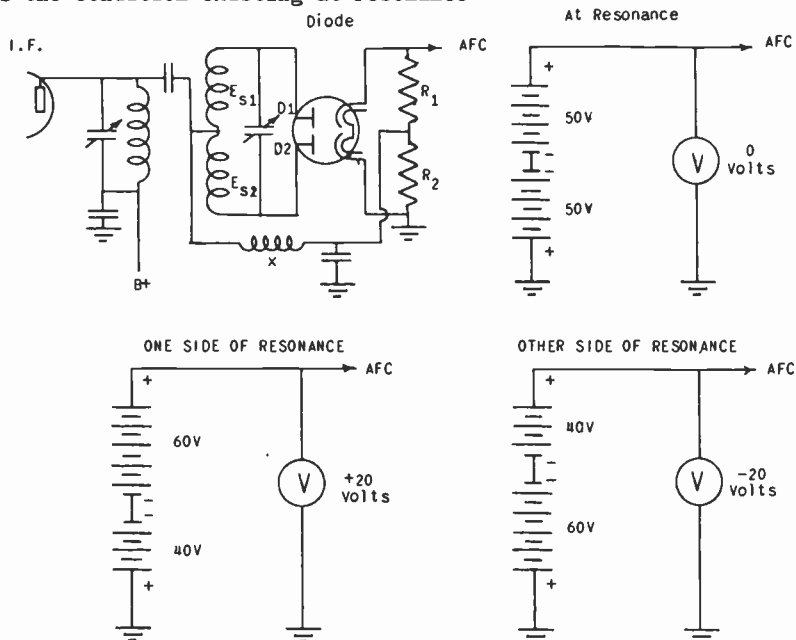

Fig. 30 Drawings to illustrate the action of the discriminator circuit.

Off resonance, the AC voltage delivered to one diode plate is higher than the voltage delivered to the other, and consequently the voltage across one diode load is higher than the voltage across the other. Now, across the ends, or from the high end to ground, a voltage will appear, equal to the difference in the voltages produced across the load resistances. Said voltage will be either positive or negative with respect to ground, depending upon which load resistor has the higher voltage across it.



This net voltage, either positive or negative with respect to ground, is then the control bias on the grid of the control tube across the oscillator.

Fig. 30 will perhaps make this point a little more clear. It is apparent that each half secondary supplies voltage to the diode plate connected to it, and that each diode has its individual load resistor. There will, therefore, be a DC voltage set up across each load resistor independently of the other, and that voltage will be dependent entirely upon the AC voltage applied to each individual diode plate, the usual rectifier action taking place as in any normal diode circuit. Since the voltage developed across each load is a DC voltage, we may represent each one by a battery.

When the incoming signal is 465 kc., which is the resonant frequency of the secondary, the voltage applied to each diode is equal, and, therefore, the DC voltages set up across each load resistor are equal. This case is represented by the first figure. If two batteries of equal voltage are connected negative to negative, as shown, no voltage would be measured across the opposite ends, or from positive to positive, since the difference between the two battery voltages is zero.

When the incoming signal is more or less than 465 kc., the secondary is no longer in resonance with the signal. Under these conditions, the voltages applied to the diodes are no longer equal and the DC voltages developed across the load resistors are unequal. The second figure shows this condition on one side of resonance; the batteries representing the DC voltages developed, as before. They are connected negative to negative as before; but this time a voltage will be measured across the opposite ends, since the difference is now a definite value. This voltage would be negative with respect to ground, since the battery with its negative end away from ground, is larger.

In the last case, the signal is off resonance in the other direction. Once again, we have unequal AC voltages applied to the diode plates and unequal DC voltages developed across the loads. This time, however, the greater AC voltage is applied to the other half of the double diode and the DC voltage developed across its load resistor is now greater. The difference voltage is now positive with respect to ground since the battery with its positive end away from ground is larger.

Referring to Fig. 29 again, when the local oscillator is generating the correct signal to produce an I.F. signal of 465 kc. there is no need of any further adjustment. The differential voltage is zero, and there is, therefore, no effect upon the control tube and oscillator circuit. Either side of resonance, a voltage, either positive or negative with respect to ground, is generated, and this in turn affects the control tube and the oscillator circuit. The oscillator frequency is thus either increased or decreased until it is correct to produce an I.F. signal of 465 kc. As this condition is approached, the differential voltage becomes less and less, and the action finally stops with about 1 volt as the differential voltage actually remaining.

This action is quite rapid, however, taking place in less than a second of time.

All along, we have stated that unequal voltages are applied to the separate diodes as the incoming I.F. signal departs from 465 kc. We will now investigate the reason for this.

The AFC I.F. transformer feeding the diodes at this point is similar to other I.F. transformers in the receiver except that the secondary is center tapped. Both primary and secondary are tuned to 465 kc., but in addition to the usual inductive coupling, we find capacity coupling between the top of the primary and the center tap of the secondary. It is the combination of the induced voltage and the capacity-coupled voltage which is applied to the diode plates. The coupled voltage is really in series with the induced voltage as follows: Whatever AC voltage may be present across the primary of the I.F. coil, that voltage will also exist across the choke X (Fig. 30). This is true, because the top ends are coupled together by a capacitor, and the bottom ends are both at ground potential by reason of the capacitors to ground at this point. Therefore, the primary voltage is always present across the choke. Another voltage is also present across each half of the secondary since it is inductively coupled to the primary. Observe that these voltages are in series with each other for either of the diodes, since the choke X is part of the return circuit path of the current through either diode.

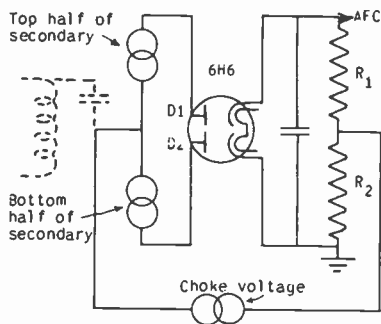

Fig. 31 Replacement generators to represent the series voltages of the diode plates of the discriminator.

To make this more clear, let us replace the induced and coupled voltages with generators in this circuit as shown in Fig. 31. Now trace the path of the current through each circuit. Starting from the cathode of diode 1, the path is through the tube, from the plate through the secondary and the choke, then through the resistor R1 to the cathode, completing the circuit. The path of the current in circuit 2 is from the cathode, through the tube, through the other half of the secondary, through the choke and back through R2 to the cathode. Obviously, for either path, the voltage in each half secondary is in series with the voltage across the choke. These conditions are true regardless of whether or not the incoming frequency is the same as the frequency

to which the primary and secondary are tuned. However, it is only at resonance that the two voltages in series add up to the same amount on each individual diode plate.

Off resonance, the phase relations of the various voltages are such that the voltage across one half secondary added to the choke voltage does not give the same sum as the voltage across the other half secondary added to the choke voltage. This is true even though the voltage across one half secondary must always be of the same value as the voltage across the other half secondary, since the whole secondary is center tapped. As stated, this is due entirely to the phase relations which change as the frequency of the I.F. signal changes.

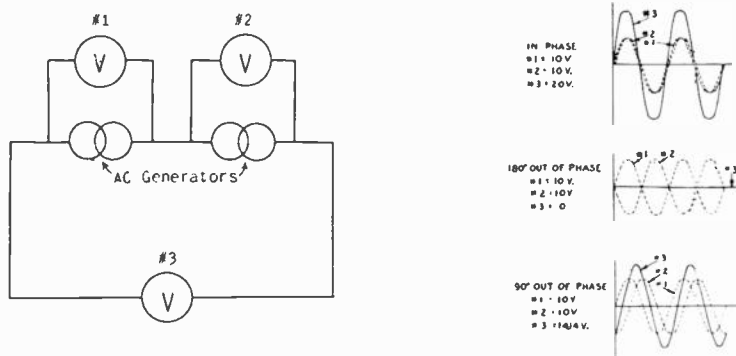

Fig. 32 Generator circuit to illustrate the effect of phase relation upon the total voltage output.

In order to make this clearer, let us review the result of placing AC voltages in series with each other as shown in Fig. 32. We will place two AC generators in series with a voltmeter across each, and another voltmeter across both of the generators. If the voltages are out-of-phase with each other, the resultant voltage is not the same as when they are in phase. First of all, what do we mean by phase? If two voltages of the same frequency go through their maximum and their zero values at a different time, they are said to be out of phase. If they go through their maximum and their zero values at the same time, they are in phase.

As shown in the first case, the voltages are in phase, since they start at the same time and reach a maximum at the same time. The resultant voltage in this case is simply the arithmetical sum. If each voltage were 10 volts peak value, the resultant voltage as measured on an AC peak voltmeter would be 20 volts. This can be done graphically by simply adding the points together to obtain the resultant voltage wave.

In the second case, the voltages are  $180^\circ$  out of phase;  $180^\circ$  out of phase means that one voltage starts  $180^\circ$  later than the

other. Remember that  $360^\circ$  is a complete cycle, and  $180^\circ$  is, therefore, one-half cycle. It is evident from the figure that the values of the two waves are equal and opposite at all times. Therefore, the resultant voltage is zero at all times.

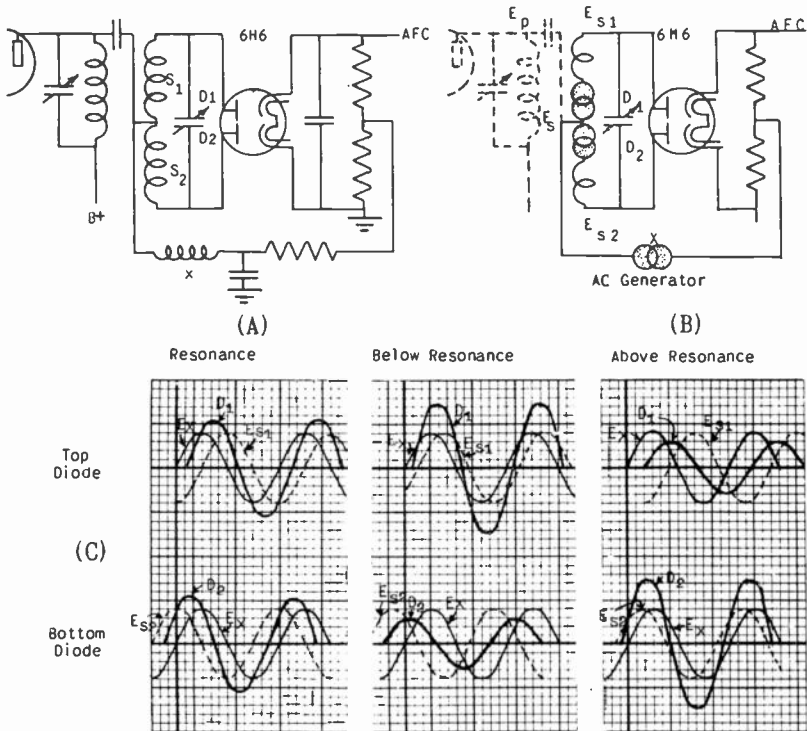

Fig. 33 (A) Diode circuit of the discriminator. (B) Discriminator diode circuit with generators inserted to show how the choke voltage adds to the induced voltage. (C) Graphs to illustrate the resultant voltages appearing at the diode plates under different conditions.

As far as these first two cases are concerned, you may easily make the experiment with an ordinary power transformer which has two separate windings delivering equal voltages. If connected together in one direction, twice the voltage of a single winding will be obtained. If connected the other way, zero voltage will result.

In the third case, things are a little different. One voltage starts  $\frac{1}{4}$ -cycle or  $90^\circ$  after the other. One voltage has reached its maximum when the other is just starting. If we add up the two waves in this figure, we will obtain a third wave which is the resultant wave of voltage. We find now that the maximum is less than twice the value of one. As a matter of fact, for a

phase difference of  $90^\circ$  as shown here, the maximum voltage of the resultant wave is 1.414 times either one of the original waves. For any phase difference between  $0^\circ$  and  $180^\circ$ ; that is, from an in-phase to a completely out-of-phase condition, the amplitude of the resultant wave will vary from maximum to zero.

Now to return to our AFC circuit and referring to Fig. 33, let us replace the voltage developed across the choke with an AC generator. You will recall that this voltage is really the primary coil voltage. Let us also replace the voltage induced in each secondary with an AC generator.

A simple explanation of the circuit conditions existing at resonance, as well as either side of resonance, will now be given.

The voltage induced in the top half secondary is  $180^\circ$  out of phase with the primary voltage, which is also the choke voltage. However, the phase of the voltage appearing across the top half secondary is something else again because of the inductance of the coils comprising the secondary windings and the phase of the current through them.

At resonance, the top secondary voltage is lagging the choke voltage by  $90^\circ$  as shown in the graph for the top diode. The resultant voltage is shown as the heavy solid line. We know that the voltage across the bottom half secondary must be  $180^\circ$  out of phase with the top, making it lead the choke voltage by  $90^\circ$ . These voltages, as well as the resultant, are shown in the graph for the bottom diode. Note that the heavy curves in both graphs are of equal amplitude, which means equal voltages applied to the top and bottom diodes at resonance.

We already know that if equal AC voltages are applied to the two diodes, then the DC voltages developed across the load resistors are equal and the resultant DC voltage, which is the AFC control voltage, is zero. This is as it should be, since no control voltage is required if the correct I.F. frequency is being generated.

When the I.F. carrier is higher than 465 kc., the voltage across the top half secondary now lags by more than  $90^\circ$ , and the voltage across the bottom half secondary consequently leads by less than  $90^\circ$ . Note that the resultant heavy line curves are no longer equal, and indicate that the bottom diode has a greater applied voltage than the top diode.

A greater voltage applied to the bottom diode will result in a greater DC voltage being developed across the bottom diode load resistor and a negative AFC voltage. A negative AFC control voltage will result in higher grid bias on the control tube across the oscillator circuit and less current will be drawn by the control tube. This is equivalent to making it appear like a larger inductance and the frequency of the oscillator will become lower. If the I.F. frequency were above resonance to begin with, that means that the oscillator frequency was too high. Thus, it can be seen that the desired action has taken place when the oscillator frequency has been reduced in the manner just described.

When the I.F. carrier is less than 465 kc., the conditions are reversed. The voltage across the top half secondary now lags by less than  $90^\circ$  and the voltage across the bottom half secondary now leads by more than  $90^\circ$ . Note that once more the heavy solid resultant curves are unequal. However, this time the top diode has a greater applied voltage than the bottom diode.

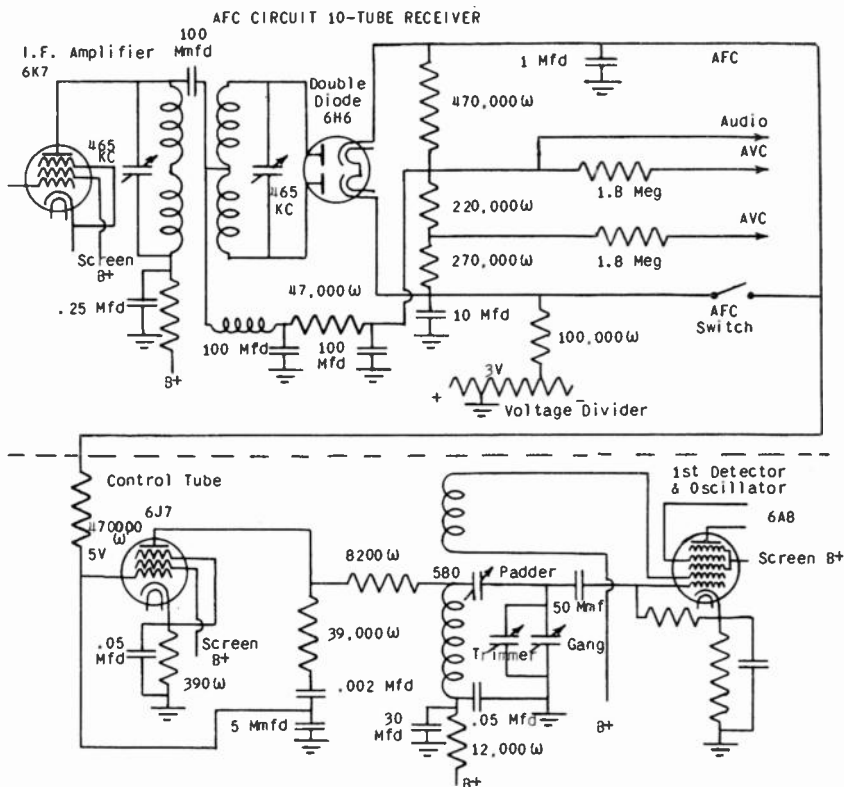

Fig. 34 Circuit diagram of AFC circuit in General Electric E101-E105.

A greater voltage applied to the top diode will result in a greater DC voltage being developed across the top diode load resistor and a positive AFC voltage. A positive AFC control voltage will result in a lower grid bias on the control tube and more current will be drawn by the control tube. This is equivalent to making it appear like a smaller inductance and the frequency of the oscillator will be higher. Since the I.F. frequency was below resonance to begin with, this means that the oscillator frequency was too low. Thus, the desired action has taken place and the oscillator frequency has been increased.

Fig. 34 gives the AFC circuit as it is actually used in the General Electric 10 tube receiver E101-E105. The oscillator coil arrangement is somewhat different, the plate feedback coil being a separate coil. However, the grid coil and associated capacitors are the same as in the simplified sketch of Fig. 29, and the circuit functions are exactly the same although a 6A8 converter is used instead of a separate oscillator tube.

Note that a resistance is connected between the oscillator coil and the control tube. It is necessary to limit the current drawn by the control tube in order to avoid placing too great a load on the oscillator.

The voltage divider and phase shifting network from which excitation of the control grid is obtained, also differs slightly from the simplified circuit, but the function is identical.

Referring to the differential voltage generating system which is the top part of Fig. 34, note that automatic volume control voltages, as well as the audio signal, are obtained from the bottom diode load resistor. This is perfectly straightforward, since the voltage developed across here, due to rectification of the modulated I.F. carrier, is DC with an audio component just as in any diode detector. The DC potential is in a progressively more negative direction from the bottom to the top end of the bottom diode load resistor. The top end of this resistor is, of course, the center point between the two load resistors. Full AVC is obtained from the top of the bottom load resistor and a smaller AVC voltage from the tap near the center. The audio signal is also taken from the top of the bottom diode load and is connected to a volume control of the usual sliding contact type. Note that the bottom end of the bottom diode load resistor is not returned directly to ground, but rather back to a point 3 volts negative on the power supply voltage divider. The 100,000 ohm resistor and 10 mfd. capacitor are simply a means of isolating the diode load resistors from any fluctuations due to hum or audio currents in the voltage divider. Connecting the load resistors back to a negative point in this manner places the whole system at a 3-volt negative potential with respect to ground. Since the AVC voltages are also taken off the bottom load resistor, this places an initial (residual) bias of 3 volts on the grids of all tubes which are on the AVC circuit.

A capacitor of 1 mfd. is connected from the top of the diode loads to ground. This gives the AFC system a longer time constant than the AVC system. In other words, the AFC action is not as rapid as the AVC action, because of this capacitor. If this capacitor is omitted or becomes open-circuited, the receiver will probably go into slow oscillations or motorboating.

A switch is provided to eliminate the AFC action by shorting the two ends of the diode load resistors together. With the AFC switch closed, the circuit functions simply as a diode detector with the AVC and audio voltages obtained just as before. However, no AFC voltage is generated, and the receiver, therefore, behaves in the conventional manner.

8. HIGH FIDELITY. In recent years, we have learned a great deal about the fidelity of radio receivers. Particularly have we heard the expression "High Fidelity" used in the advertising of many receivers. Fidelity of a receiver is basically considered to be its ability to reproduce any frequency *naturally*. However, even though a receiver may reproduce music that is pleasant to the ear, it does not necessarily mean that its quality is high fidelity in nature. In order to reproduce all instruments of an orchestra faithfully, it is necessary for the complete receiver, including the loudspeaker, to reproduce a frequency range from 50 to 7500 cycles without more than 5 db variation in audio volume. The power output should not be less than 10 watts and the percentage distortion must be less than 5%. The average good receiver on the market, although it reproduces from about 80 to 4000 cycles, often has a variation of as much as 30 to 40 db over this frequency range.

Contrary to popular belief, the A.F. amplifier is not the main factor in the obtaining of high fidelity in a receiver. It is comparatively easy to obtain the necessary frequency characteristic by the use of high quality transformers, resistors, capacitors, etc. The necessary power output can be obtained by the use of large power tubes in parallel or push-pull.

Before looking into the high fidelity characteristics of the R.F. and I.F. stages, it may help us in approaching this discussion to look first at the broadcast station. Most broadcasting stations are assigned transmitting frequencies on the basis of 10 kc. separation. A 5000 cycle audio note requires a channel 10 kc. wide; the lower sideband will be 5 kc. below the carrier frequency and the upper sideband will be 5 kc. above the carrier frequency. Under these conditions, broadcast stations operating 10 kc. apart could not transmit over a 5000 cycle note. If they do, the sidebands will overlap, causing excessive interference and distortion.

The R.F. section of a receiver must be designed to pass a wide band of frequencies each side of resonance to prevent the suppression of high audio frequencies. For the perfect reproduction of a 10,000 cycle audio note, it is necessary that the R.F. and I.F. amplifiers be designed to pass a band of frequencies 20 kc. wide with no attenuation. Under these conditions, the selectivity of the receiver is very poor, thus rendering it unsatisfactory for long-distance reception. Local stations are generally separated by at least 50 kc., so that the selectivity problem is of little consequence for local reception, and the receiver may be adjusted for high fidelity reproduction with no adjacent channel interference.

A receiver designed specifically for high fidelity reception is not satisfactory for the reception of weak signals from distant stations, so manufacturers do not design their sets with only the former objective in mind. On those receivers incorporating high fidelity circuits, a control is provided on the front panel whereby the selectivity and fidelity may be varied at will. When



high fidelity reception is desired from a local station, this control may be adjusted so as to decrease the selectivity of the receiver, thereby making it possible to pass the necessary band of sideband frequencies through the R.F. and I.F. sections of the receiver. Then, when the same receiver is to be used for long-distance reception, the "Selectivity-Fidelity" control is adjusted in the opposite direction where the selectivity of the set becomes exceedingly sharp. In this condition, the audio reproduction from the receiver cannot be termed "high fidelity" because the selectivity of the R.F. and I.F. sections of the receiver will not permit the passage of a sufficiently wide range of sideband frequencies for the higher A.F. notes to reach the second detector.

As a rule, the fidelity control on modern receivers sharpens or broadens the selectivity of the I.F. amplifier. This is accomplished by several methods. One of these methods makes use of a tertiary winding or third winding in addition to the usual primary and secondary in the I.F. transformers. This third winding is tuned to absorb energy from the secondary winding, and this tends to broaden out the response characteristics of these transformers. The amount of energy absorbed by each tertiary winding is controlled by a variable resistor; hence, the bandwidth of the I.F. amplifier may be varied to any degree desired within the limits of the circuit arrangement. In some receivers, one I.F. stage omits this tertiary winding. On the tube in this stage, a bias control circuit is included which is mechanically connected to the control of the tertiary windings. Thus, as the absorbing effect of the tertiary windings is increased, and the overall sensitivity of the receiver is decreased accordingly, the bias on the other I.F. stage is reduced, increasing the sensitivity of the receiver. As a result, the overall sensitivity of the receiver is not reduced appreciably, although the selectivity may be varied at will.

Another method of varying selectivity in I.F. stages is by varying the coupling between the primary and secondary. The transformers are so designed that the coils may be moved further apart or closer together by means of a mechanical system coupled to a control knob on the front panel. As the coils are moved together, the closer the coupling, and consequently the wider the band passed. As the coils are moved apart, a smaller coupling is present with a corresponding increase in selectivity. This system also uses a variable cathode bias system on the first stage. It is coupled to the fidelity control, to compensate to some extent for the loss in sensitivity when the bandwidth is increased.

Another factor in the fidelity of a receiver is the speaker system and cabinet design. Some receivers use a multiple speaker system, fed by a dual audio channel. In this system, one audio channel and a speaker are used for low frequency response, while a separate audio channel and either one or two speakers are used for the high frequency response.

Present practice, however, is to use a single large speaker rather than a dual or triple speaker system. Speakers 10" to 12" in diameter are used to eliminate distortion and to obtain the

highest possible efficiency. Some speakers use aluminum voice coil wire to reduce the weight and thus increase the high frequency response. In other speakers, the cone is made with a varying thickness of paper so that the speaker response to both low and high frequencies is uniform.

One undesirable characteristic of loudspeakers is that they are directional; particularly on high frequencies. With most dynamic speakers, all frequencies above 3000 cycles are radiated within  $20^{\circ}$  of the cone axis. For that reason, practically all the high frequencies are projected nearly straight out from the axis of the cone, and, as a result, very few of them are heard by anyone listening outside of this narrow band. This characteristic is shown in Fig. 35A; the darker shaded area indicating the high frequency radiation. The use of diffuser vanes or masks over the speaker tends to overcome this difficulty to some extent. The size, shape, and placement of these diffusers have a very definite relation to the size of the cone and the frequencies to be reproduced. Fig. 35B shows the placement of the diffusers, and Fig. 35C shows the approximate diffusion of the high frequency signals.

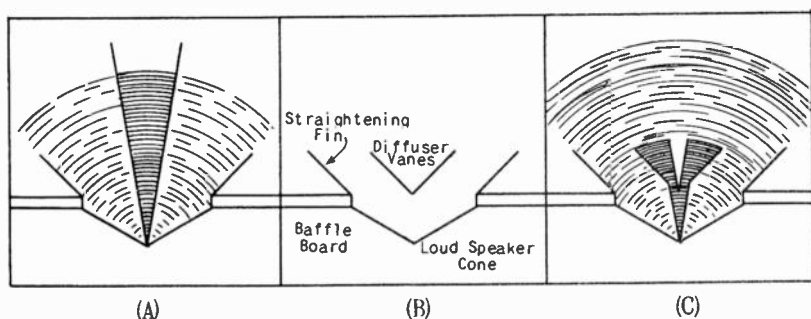

Fig. 35 (A) Showing the narrow angle of high-frequency radiation from a loudspeaker cone. (B) The diffuser vanes mounted in the center of the cone to spread the angle of high-frequency radiation. (C) Showing the effect of the diffuser vanes. The radiation of high audio frequencies are spread out from the cone.

The human ear is known to be insensitive to certain frequency ranges. Particularly is the ear insensitive to low frequencies when the intensity falls to a low level. If it were possible to reproduce musical programs in the home with the same intensity of sound as the original in the studio; then the reproduction would sound natural to the listener. However, in the home, this reproduction would be far too loud, and, as a result, most reproduction is comparatively soft, resulting in an apparent lack of low frequencies in the reproduction as heard from the loudspeaker. Practically all modern receivers employ a bass-compensated volume control which automatically attenuates the highs more than the lows as the volume is lowered. Although this system of bass compensation greatly aids the naturalness of reproduction, it is not as satisfactory as the specially designed automatic bass

control which we will next discuss. This system provides an adequate low frequency compensation that is entirely independent of the volume control setting, and also independent of any change in percentage modulation of received signals.

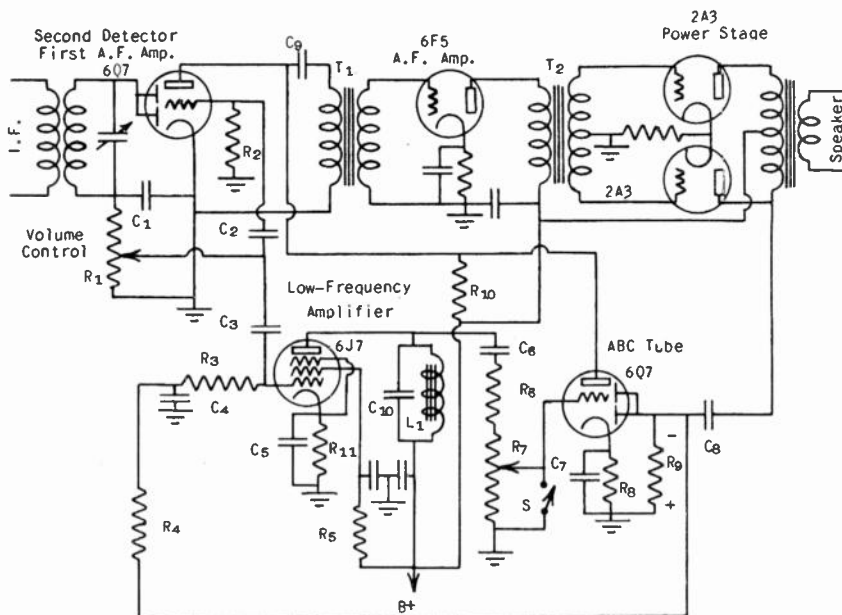

Fig. 36 Wiring diagram of automatic bass control circuit.

The wiring diagram for this bass compensating arrangement is shown in Fig. 36. An additional A.F. amplifier and automatic control circuit is employed in conjunction with the regular audio frequency amplifying system of the receiver. In Fig. 36, the first 6Q7 is the second detector and first audio amplifier. The 6F5 is the first A.F. amplifier, which, in turn, feeds the push-pull power stage consisting of two type 2A3 tubes. This constitutes the regular audio channel of the receiver. The bass compensating arrangement consists of the 6J7 low-frequency amplifier and the second 6Q7 automatic bass control tube. The function of the circuit is as follows:

The audio frequency voltages developed across the volume control R1 are fed through the condenser C2 to the grid of the first A.F. amplifier, which is the triode section of the 6Q7. Also, the A.F. voltages developed across R1 are fed through condenser C3 to the grid of the 6J7. The plate circuit of the 6J7 contains a load impedance consisting of the parallel tuned circuit L1-C10. This parallel tuned circuit is adjusted so as to resonate sharply at 75 cycles. Hence, at higher audio frequencies, the

impedance of the parallel tuned circuit constitutes a very low plate load, but at the audio frequencies in the neighborhood of 75 cycles, the plate load impedance of the 6J7 is very high. Since the voltage amplification of any vacuum tube depends upon the load impedance in the plate circuit, it follows that only the low frequencies will be amplified by this tube. The amplified output of the 6J7 is fed through C6, R6, and R7 to the grid of the duplex-diode triode 6Q7 tube. The resistance R7 in the grid circuit of the triode section is variable, thus making it possible to control the amount of bass compensation desired. When it is desired to operate the receiver without the automatic bass-compensating circuit, the switch S may be closed. The amplified output of the triode section of the 6Q7 is fed back to the input of the first audio frequency transformer T1 through condenser C9. The resistance R10 is serving as the plate load resistance for the triode section of the 6Q7 first audio amplifier, and is also the plate resistance for the 6Q7 ABC tube; hence, the output of the 6Q7 ABC tube is fed directly to the input of the regular audio channel of the receiver through transformer T1.

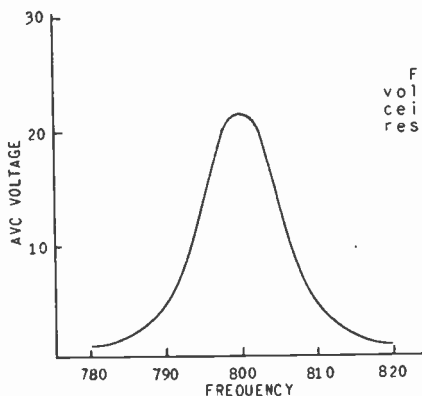

Fig. 37 Showing the AVC voltage developed as receiver is tuned through resonance.

It was previously stated that bass compensation is needed only when the volume level of the receiver is low. In this circuit, a special arrangement is provided wherein the regular audio channel of the receiver is supplied with additional low-frequency energy only at low signal levels. The diode plates of the 6Q7 ABC tube are connected to the plate of one of the push-pull tubes through condenser C8. At high A.F. outputs from the 2A3, the diode plates of the 6Q7 will be driven to a positive potential with respect to the cathode, and a rectified diode current will flow through resistors R9 and R8. Upon passing through R9, a voltage is developed with the grounded side positive and the ungrounded side negative as indicated in Fig. 36. By careful inspection, it will be found that this resistance (R9) is connected in such a manner as to supply a portion of the grid bias to

the 6J7 low frequency amplifier through resistances R4 and R3. The initial bias on the 6J7 is developed across the cathode biasing resistance R11. At high A.F. output from the 2A3, there will be sufficient diode current through R9 to develop a bias voltage on the 6J7 sufficient to cut off the plate current entirely through this tube, thus making it inoperative. Hence, at high volume, the automatic bass control on the receiver is attenuated. As soon as the volume is reduced, the rectified diode current through R8 and R9 decreases, the voltage drop across R9 decreases and the grid bias on the 6J7 low frequency tube is reduced to the point where the tube is again operative. Then the low audio frequencies are amplified through the 6J7 and fed from the plate circuit of the 6Q7 ABC tube to the input of the A.F. channel, thus reinforcing the low frequency reproduction from the speaker and maintaining natural tone quality.

9. RESONANCE OR TUNING INDICATORS. In modern receivers, the resonance or tuning indicator has become quite popular. This is particularly true since AVC became common, because receivers equipped with AVC lend themselves readily to tuning indicator devices with a minimum of added expense.

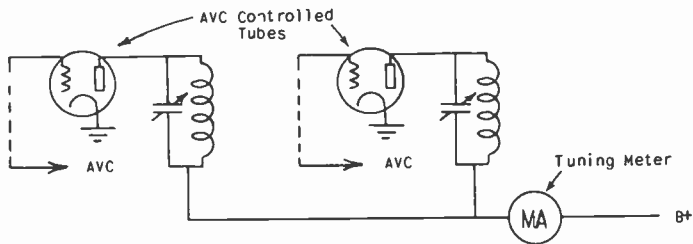

Fig. 38 Tuning meter connected in plate lead of AVC controlled tubes.

First, let us determine what is meant by a "resonance indicator". A resonance indicator may be described as any instrument which gives a visual indication of the tuning of the receiver; that is, any instrument which indicates, by positive visual means, when the receiver is tuned to resonance. When a receiver is tuned to a point slightly off resonance, the quality of reception usually suffers to a great degree. A tuning indicator is employed to speed up the tuning of the receiver by untrained individuals, and consequently to secure better reproduction.

There are several types of tuning indicators now in use, and we will describe in the following paragraphs, some typical circuits using the meter type of indicator, the "shadowgraph", the "tuning eye", and the saturated core type of indicator.

Before studying these different types of tuning indicators, let us consider Fig. 37. This figure shows the AVC voltage developed as the receiver is tuned from one side of resonance to the

other side. Assuming a resonant point at 800 kc., the maximum AVC voltage will be developed at that frequency. At a higher or lower frequency, the voltage developed is lower; thus, it is only necessary to convert this voltage into a visual indication.

Perhaps the simplest type of tuning indicator consists of a milliammeter in the plate supply lead of the AVC controlled tubes. Such a circuit is shown in Fig. 38. It is not necessary to connect this meter in the plate circuit of all the tubes. If a sensitive milliammeter is used, one tube is sufficient, and two are all that are ever required. The meter will read the current drawn by the controlled tubes. As super-control tubes are always used, and their bias is controlled by the AVC voltage, the plate current will decrease as the signal strength in the second detector is increased, being at a minimum when the set is tuned to resonance.

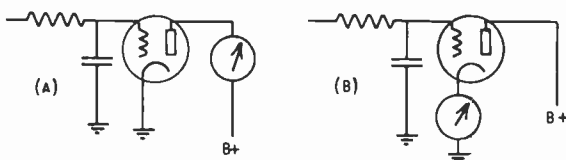
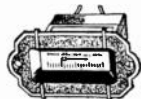

Fig. 39 Using a vacuum tube voltmeter as a tuning indicator.

A method similar to this is the so-called vacuum tube voltmeter system, in which a separate tube is used as a vacuum tube voltmeter. As seen from Fig. 39A, the grid of the tuning meter tube is connected to the AVC circuit. As a result, the bias on the tube, and consequently the plate current, will vary directly as the signal is tuned in. As described above, this meter is tuned to a "minimum"; that is, the meter will give a minimum reading when the receiver is tuned to exact resonance. Fig. 39B shows a variation of this system in which the tuning meter is placed in the cathode circuit. This system is rarely used, and for that reason, we will not discuss it further.



Fig. 40 Tuning meters.



Tuning meters have a scale marked with un-numbered graduations. Two of these instruments are shown in Fig. 40. An arrow is drawn on the scale, and it is labeled "tune for greatest swing". This means that when the resonant circuits are tuned exactly to the frequency of the incoming signal, maximum deflection will be obtained in the direction of the arrow. These tuning meters are available in different sizes, ranging from 5 to 50 milliamperes.

The Shadowgraph meter, as employed extensively by several manufacturers, operates in a manner similar to the tuning meter;

however, there is a slight difference in the mechanical construction. It is arranged so that instead of a needle indicator, a shutter is employed which intercepts a light beam from a pilot lamp which is directed toward a translucent screen. The construction of this indicator is shown in Fig. 41. At A, a cross-sectional view of the movement is shown, and B illustrates the internal construction. The coil winding may be connected directly

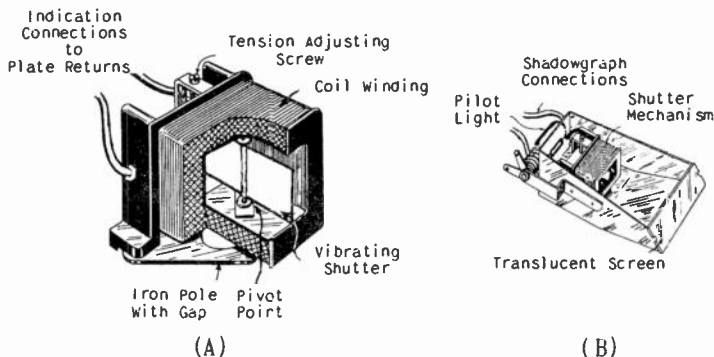

Fig. 41 (A) Cross-sectional view of Shadowgraph coil. (B) Internal view of Shadowgraph tuning indicator.

in the plate circuit of one or more of the AVC controlled tubes. The plate current passing through the coil causes a deflection of the vibrating shutter about the pivot point. The shutter position varies with the plate current; hence, the light beam may be obstructed to cause either a wide or a narrow shadow to appear on the translucent screen. As the incoming signal is tuned to resonance, the shutter is moved parallel to the light rays, and the shadow on the screen becomes narrower. Resonance is indicated by minimum shadow width. When off resonance, the shutter returns to its normal, angular position, where it obstructs the light beam from the pilot lamp to a greater extent. Thus, the width of the shadow on the translucent screen increases. In some receivers, a separate tube is employed to operate the Shadowgraph; whereas, in others, the plate current of the controlled tubes passes directly through the Shadowgraph coil.

The most widely used tuning indicator in modern all-wave receivers is the so-called "Magic Eye" or "Tuning Eye". It receives its name from the fact that its appearance resembles the human eye. This tube is actually a combination triode and a cathode ray tube in one envelope. The triode is constructed much the same as an ordinary triode, and the cathode ray section consists of a cathode light shield, a ray control electrode, and a fluorescent target. When the tube is used as a tuning indicator, the triode section acts as a DC amplifier, and the fluorescent screen of the cathode ray section shows a narrow or wide shaded area, depending upon the value of voltage fed to the grid circuit of the triode.

The action of the tuning eye is as follows: The target is operated at a positive potential with respect to the cathode, and consequently attracts electrons from the cathode. When electrons are flowing to the whole circumference of the target, it has the appearance of a ring of light.

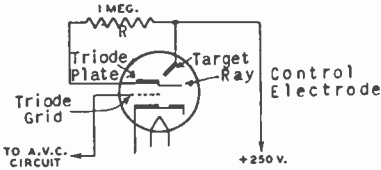

Fig. 42 Symbol and wiring connections for the 6E5 tuning indicator.

A ray control electrode is mounted between the cathode and the target. When the potential of this electrode is less than the target, it repels electrons by its electrostatic field, and these electrons do not reach the target, or rather, that portion of the target which lies behind the ray control electrode. Since that portion of the target which is shielded from electrons does not glow, the control electrode, in effect, casts a shadow on the target. The angle of this shadow varies from approximately  $100^\circ$  when the control electrode is at maximum negative potential with respect to the target, to  $0^\circ$  when the potentials of the control electrode and the target are approximately the same.

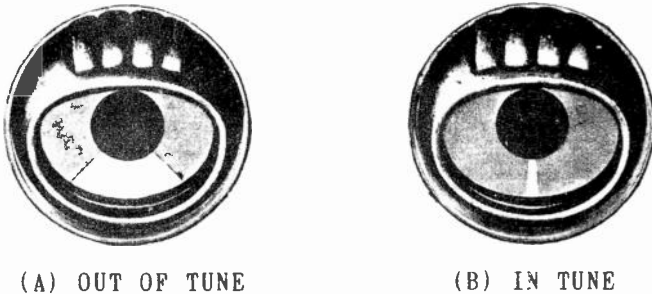

Fig. 43 (A) width of shadow when receiver is out of tune. (B) width of shadow when receiver is in tune.

In the application of the electron ray tube, the potential on the control electrode is determined by the voltage on the grid of the triode section as can be seen from Fig. 42. The flow of the triode plate current through resistor R produces a voltage drop which determines the potential of the control electrode. When the voltage of the triode's grid changes in the positive direction, the plate current increases, the potential of the control electrode goes down because of the increased drop across R and the shadow angle widens. When the potential of the triode grid changes in the negative direction, the shadow angle narrows. The appearance of the shadow for two values of grid bias is shown at A and B in Fig. 43.



The details of the 6E5 electron ray tube are shown in Fig. 44. Electron ray tubes are widely used as tuning indicators in radio receivers. In this use, the AVC voltage is applied to the grid of the triode. Since AVC voltage is at maximum when the set is tuned to give maximum response to the station, the shadow angle is at a minimum when the set is tuned exactly to the desired station. Thus, the electron ray tube gives a convenient, visual indication of correct tuning.

Fig. 44 Details of the 6E5 electron ray tube.

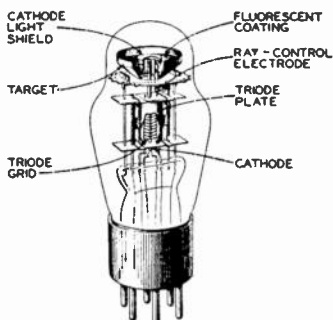

Recently, a second electron ray tube indicator known as the 6G5 has been placed on the market. In outward appearance and internal construction, the 6G5 is very similar to the 6E5. The only difference between these two is that the 6E5 has a sharp cutoff triode which closes the shadow angle on a comparatively small value of AVC voltage; whereas, the 6G5 has a remote cutoff triode which closes the shadow angle on a larger value of AVC voltage.

The final system to be discussed depends upon the saturation of a transformer. This saturation causes the brilliance of a lamp or lamps to vary in direct proportion to the signal strength. Direct current flows through one winding of a transformer, producing saturation, and thereby affecting the impedance of the other windings. The relation between the amount of DC current flowing in the primary of the transformer and the impedance of the secondary is shown in Fig. 45.

As can be seen, when the direct current increases, the impedance decreases. The direct current sets up lines of force in the iron core, causing the molecules of the iron to become aligned. The higher the value of DC current, the greater the amount of the magnetism. If an AC current is allowed to flow through the secondary winding, it will have little or no effect upon the magnetic flux existing in the core. Since the impedance which a coil offers to the flow of AC depends upon the change in magnetic flux which that current produces, it can be seen that the impedance of the coil drops to a low value for high values of DC current in the primary.

Fig. 46 illustrates a fundamental circuit of a tuning indicator using this principle. The primary winding carries the DC current supplied by a battery and controlled by the variable resistor R. The secondary is connected in series with a pilot lamp and a source of AC voltage to supply the filament of the lamp.

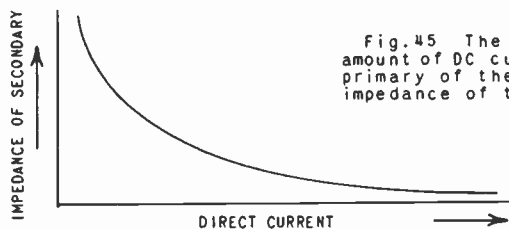

Fig. 45 The relation between the amount of DC current flowing in the primary of the transformer and the impedance of the secondary.

Now if the primary circuit is open, the impedance of the secondary is high; a low value of AC current passes through the secondary circuit, and the pilot light glows very dimly. However, if the primary circuit is closed and the current in the primary increased by lowering the value of resistance R, the impedance of the transformer secondary will decrease. This, in turn, allows more AC current to flow and causes the brilliancy of the lamp to increase. When the core of the transformer is saturated due to the DC current in the primary, the impedance of the secondary is at a minimum and the pilot lamp will have its maximum brilliancy.

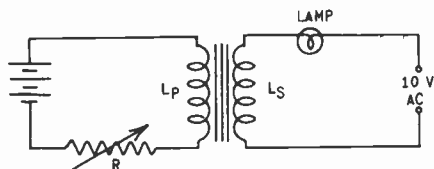

Fig. 46 illustrating the fundamental principle of transformer saturation as applied to tuning indicator.

To apply this principle to a receiver, it is only necessary to substitute a source of DC voltage for the battery of the primary circuit. A DC amplifier is employed for this purpose; and it is fed by the AVC circuit. Fig. 47 illustrates a practical arrangement. In this circuit, the AVC voltage is applied to the grid of a remote cutoff pentode, and the plate current is passed through the primary of the tuning indicator transformer. A separate filament winding on the power transformer supplies the AC voltage for the indicator lamp. Now, as the AVC voltage increases, the plate current of the DC amplifier decreases. This will increase the impedance of the transformer secondary, causing the lamp to decrease in brilliancy. Then, since the AVC voltage is at maximum when the receiver is tuned to resonance, it follows that the receiver will be correctly tuned when the tuning lamp is at minimum brilliancy.

The transformer used in commercial receivers, differs from a standard transformer in that a split secondary winding is used.

When an AC voltage is applied to the secondary of a standard transformer, there is an AC voltage induced in the primary. This voltage would react on the DC amplifier and cause difficulty in its operation. By using a split secondary winding, the magnetic flux of the two parts of the winding can be made to oppose, thus having no effect on the primary.

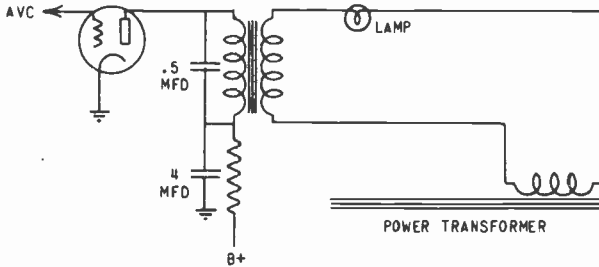

Fig. 47 A practical arrangement of the saturation principle for tuning indicators.

Fig. 48 shows how such a transformer is constructed. The primary winding L1 is wound on the center leg of the core, while the secondary winding is in two sections, L2 and L3, which are wound on the two outer legs of the core. These two secondary windings are connected in such a way that the AC currents flowing in each of the secondary windings induce equal and opposite voltages in the primary winding so that no net AC voltage results in

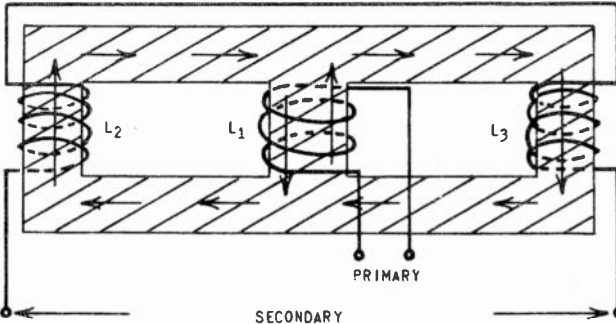

Fig. 48 Showing the construction of the transformer used for tuning indicators employing the saturation principle.

that winding. The arrows in Fig. 48 show the direction of the flux due to the two sections of the secondary during one alternation, and it is quite evident that the flux in the center leg, which is due to the current in L2, is canceled by the flux due to L3, so that there is no net voltage induced in the primary winding. In commercial practice, it is physically impossible to obtain two windings exactly equal. For that reason, the primary winding is usually shunted with a .5 mfd. capacitor as shown in

Fig. 47. This capacitor will eliminate any small voltage appearing in the primary due to an inequality in the two secondary windings.

An interesting adaptation of the saturated core tuning indicator is shown in Fig. 49. In this circuit, a series-parallel arrangement of four red lamps is in series with the transformer secondary and three green lamps are in parallel with the transformer secondary. These are so connected that when no signal is being received, the red lights are the greatest brilliance, but when the receiver is tuned to a station, the green lamps glow brightest.

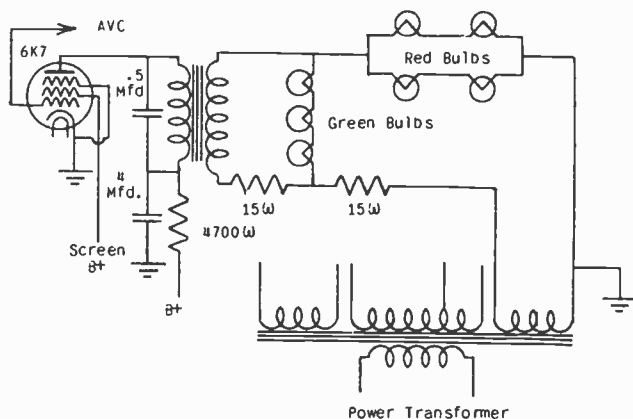

Fig. 49 Electrical tuning indicator as employed in a popular receiver.

We will now analyze the circuit in more detail. For a moment, let us consider the lamp circuit only. The green lamps are all in series and the red lamps are arranged in a series-parallel connection. Neglecting the transformer secondary entirely, we find that the green lamps will be brightly lighted and the red lights dimly. This is due to the fact that only half as much current will flow through each red lamp as through each green lamp. It is obvious that the current will divide between the two separate paths provided by the circuit arrangement of the red lamps, and half as much current through the red lamps means only a quarter as much power and much less illumination, while the green lights are at full brilliance. However, if we were to short out the green lights, the entire lamp voltage supply would be applied to the red lights with the exception of a small drop across the 15 ohm series resistor.

The reactance of the transformer secondary across the green lamps is some 500 ohms with no current in the primary. This is so high that it presents negligible shunting effect, and the green lamps glow brightly. However, as the current increases in the primary, the secondary reactance gradually decreases to approximately 25 ohms. This low reactance practically short-circuits the

green bulbs with a resultant increase in red illumination. For intermediate values of current, the secondary offers a partial shunt only and the green lights are somewhat decreased in brilliance, while the red lights are somewhat increased.

The current in the primary is simply the plate current of the tube connected to it. This tube has a rather low initial bias which is furnished by the cathode resistor. This low bias results in comparatively high plate current and the transformer primary is almost completely saturated. We found that this caused the green lamps to be shorted and the red lamps to be brightly lighted. This is the condition which exists when the receiver is not tuned to a signal and no AVC voltage is being developed.

As a signal is tuned in, the AVC voltage builds up and is applied to the control tube. The increased bias decreases the plate current. We found a decreased plate current resulted in less saturation of the transformer, and consequently, less shunting effect of the secondary across the green lamps so that they were permitted to approach the brightly lighted condition, with consequent reduced brilliance of the red lamps. A combination of red and green light in the proper balance will produce white light. Therefore, the illumination goes through a gradual change from red to white to green, as the receiver is tuned through a signal.

10. AUTOMATIC TUNING SYSTEMS. Human nature sometimes has the habit of seeking unconsciously the easiest way of reaching a desired end. This is true in the case of tuning radio receivers. The easier it is to change from one radio program to another, the better the average person likes a receiver. Realizing the presence of this trait of human nature, radio manufacturers have taken steps to make it as easy as possible for the average person to tune a radio receiver. Automatic tuning of one form or another is the radio manufacturer's offering in this direction.

Automatic tuning devices may be roughly divided into three general classes. These are the dial type, similar in action to a telephone dial; the push-button type, operated either mechanically or by a motor; and the "Mystery Control" system, in which the dialing or tuning unit has no mechanical or electrical connection to the radio receiver. It would be impossible to describe every unit used, since practically every manufacturer has some slight variation in the particular method of adapting the basic system to his receiver. However, we will cover typical examples of the various basic tuning systems. With a thorough knowledge of these basic systems, you will be able to analyze the method of operation of any automatic tuning system encountered.

Several years ago, some manufacturers attempted to use a push-button system of tuning involving a motor and an intricate system of gears, cams, and switches. These systems were not popular, as they lost their adjustment very easily, resulting in poor quality and high noise level. With the advent of AFC the necessity of extreme accuracy was no longer present, because the AFC circuit will tune the receiver properly even though the auto-

matic system be as much as 2 kc. off resonance. Consequently, simple tuning systems which are accurate within 1 kc. will prove satisfactory in actual use.

Perhaps the simplest automatic tuning system is the mechanical push-button type. Details of this system are shown in Fig. 50. A split or double gear is mounted directly on the gang shaft. This split gear consists of two thin gears, one beside the other.

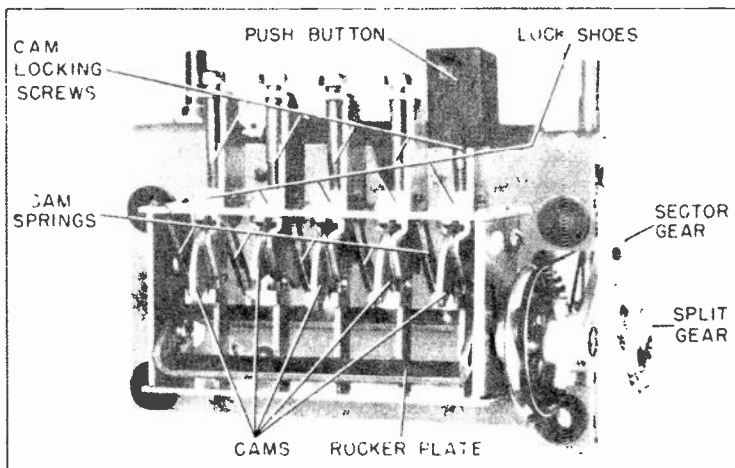

Fig. 50 Illustrating the construction of a mechanical push-button system.

One is free to move on the gang shaft and the other is fastened to the shaft. By means of this split gear, back lash is eliminated between the gang shaft and the sector gear. From this figure, you will note that the sector gear, as its name implies, is a section of a large gear. The ratio between these two gears is such that a rotation of  $180^\circ$  in the gang is obtained by a rotation of from  $60^\circ$  to  $75^\circ$  of the sector gear. The sector gear is secured to the rocker plate, a flat bar which is rotated around its axis by the cams on the push-button shafts. These cams are locked in position by the cam-locking screws. Since the sector gear is fastened directly to the rocker plate, it follows that the position of the rocker plate determines the tuning of the ganged condensers. The adjustment of this type of tuning is easily made. The few steps are as follows:

1. Remove the push-button from the push arm.
2. Loosen the cam-locking screw one-half turn.
3. Using the manual tuning control, tune in the desired station.
4. Press the push arm in as far as it will go and accurately retune the station.
5. With the push arm still held down, tighten the cam-locking screw.
6. Replace the push-button.

Now let us see briefly how this system operates. As previously stated, we know that the position of the rocker plate determines the tuning of the gang. Now, examining Fig. 50, you will note that the cam located in the second position from the left is not in the same position as the rest. If this push-button is pressed, the back of the cam will touch the rocker plate first. The cam is locked in place; it cannot move, and so the rocker plate must move, which action changes the tuning of the gang. This movement will continue until the front of the cam touches the front part of the rocker plate. At that point, the pressure on both sides of the rocker plate will be equal, and no further movement of the rocker plate can occur. Although this system is extremely simple, it is also quite accurate, and in many cases it is used with good results even without the aid of AFC.

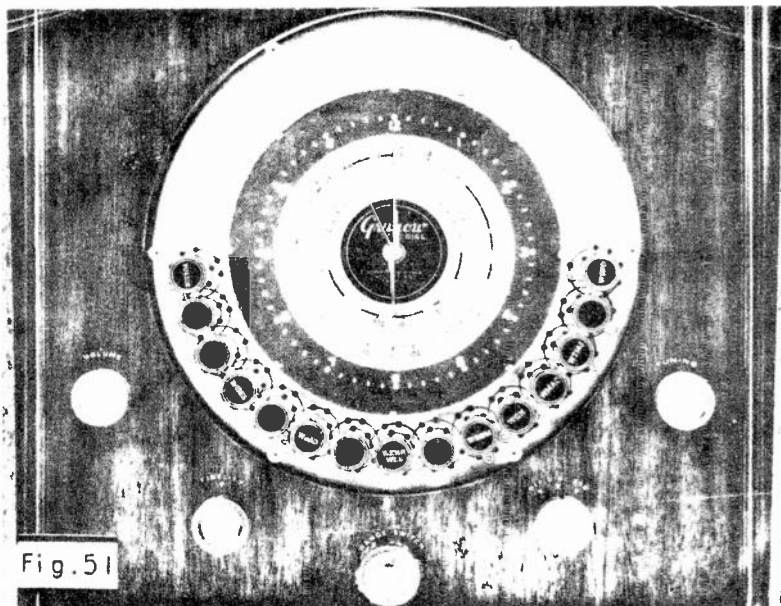

Fig. 51 The telephone dial system of automatic tuning.

Another method of automatic tuning is the telephone type system of Fig. 51. This system enables the operator to tune to any one of 15 stations with absolute accuracy. The tuning is accomplished by depressing the button corresponding to the desired station, and, at the same time, turning the dial either right or left toward the bottom of the dial. When the proper point is reached, the dial plate encounters a stop, and upon removing the finger from the button, the desired station is received. There is no excessive noise or interference during this tuning procedure because when the push-button is depressed, the audio

system of the receiver is automatically short-circuited. Then, upon releasing the button, the audio circuit is again made operative, and, should the mechanical tuning system leave the station slightly mistuned, the AFC circuit brings it into exact resonance and the station is heard to the maximum capability of the receiver.

There are two types of electrical push-button systems in use today. In one system, the electrical characteristics of the R.F. and oscillator circuits are changed by switching in and out additional capacity or inductance to change the tuning of the receiver. The other uses a motor system which drives the gang condenser through a gear train to the desired tuning position.

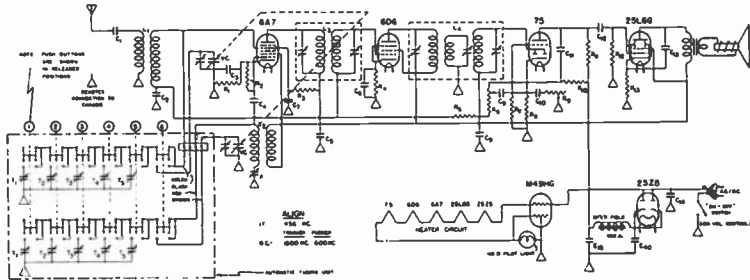

Fig. 52 A push-button system in which the capacity of the R.F. and oscillator tuned circuits is changed by trimmers.

In Fig. 52, we see an example of a push-button switch arrangement in which the capacity of the R.F. and oscillator tuned circuits is provided by trimmer type capacitors. A six-position push-button switch is used, which provides five pre-selected or pre-tuned stations, and the sixth position throws the gang condenser into the circuit. This switch is so arranged that when any button is pushed, it locks itself in position, but releases any other button that might be engaged. Now, let us see what the operation of this switch accomplishes.

When push-button #6 is engaged, we find by tracing that the gang is in the circuit, and so all tuning is manual. If we trace the circuit on through the switch, we will find that no other connections are made. Now, let us assume that push-button #1 is engaged, which automatically releases button #6. Now, we find that one T1 trimmer is in the R.F. circuit and one T1 trimmer is in the oscillator circuit. If these trimmers are adjusted to tune a station, the same station will be tuned in every time push-button #1 is engaged. And so, each of the five push-buttons can be depressed in turn and a different station tuned in by means of the individual trimmers. These trimmers are always easily accessible either from the front or back of the receiver.

In Fig. 53, we see practically the same circuit. The switch is slightly different, but we have the switching in and out of capacitors in the R.F. circuit the same as before. However, the oscillator circuit uses variable iron-core inductances for tuning. These are used in the oscillator circuit for a very definite





purpose. Trimmer capacitors, even the best, have the characteristic of changing capacity with changes in temperature. This would mean very definite detuning, resulting in poor quality. To remedy this condition, the variable iron-core inductances are used in the oscillator circuit, which is the most critical.

There are two types of motor-driven tuning systems. Basically, they are similar in that they both break the motor-operating circuit when the tuning gang is in the correct position. However, the method of accomplishing this is different in the two systems.

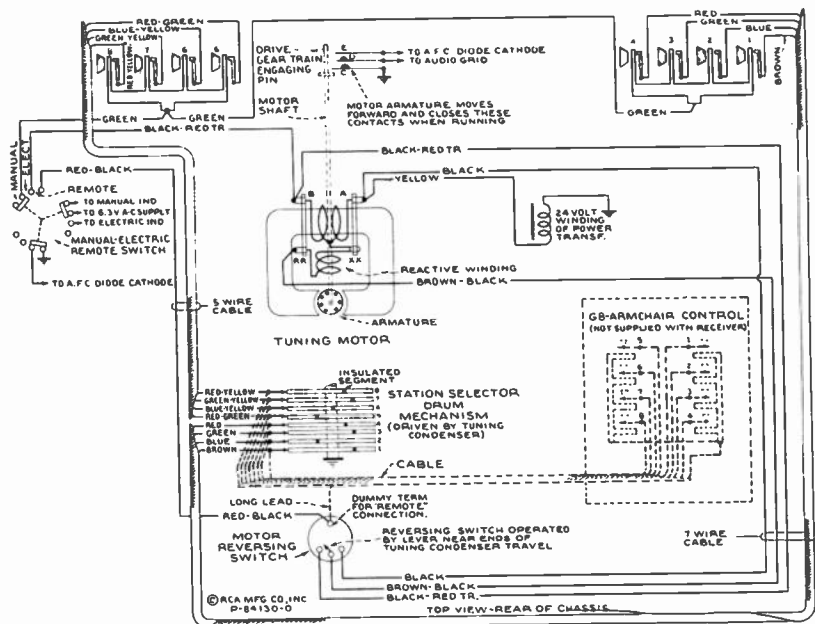

Fig. 54 A motor-driven tuning system.

In Fig. 54, we see a circuit typical of the first of these two systems. This mechanism consists essentially of a quick engaging and disengaging reversible electric motor, tuning condenser driving gear train, and eight mechanically interlocked station selector push buttons (pushing one button releases all others), which are respectively wired to eight adjustable station selector contactor discs (each with a motor stopping insulated segment), mounted on a drum which is direct-coupled to the gang tuning condenser shaft. The arrangement permits any one of eight pre-determined stations to be electrically tuned in by merely touching the correct push-button. If all eight buttons are inadvertently locked in, firmly pushing the right hand button will release them.

When the motor is not energized, the armature is pushed to the rear or slightly out of the magnetic center by tension of contact spring C, and the motor shaft is dis-engaged from the driving gear train. Pressing in any one of the eight push-buttons

will complete the motor circuit through a station selector contactor disc, assuming that the "Manual-Electric-Remote" switch is in "Electric" position, and that the insulated segment in the contactor disc is not opposite its contactor. As the motor starts, the armature will be drawn forward, due to solenoid action, and the pin on the end of its shaft will engage the arm on the small main pinion gear (not shown), thereby driving the tuning mechanism. At the same time, contact springs E and D will be grounded, causing suppression of audio amplification and automatic frequency control during the tuning cycle. The motor will continue to operate until the insulated segment in the selector disc breaks the motor circuit, whereupon spring C will instantly disengage the driving pin from the arm on the small pinion driving gear and open contacts E and D. Pushing another button will cause the above-mentioned cycle to be repeated, except that the motor will be interrupted by the insulated segment on a corresponding disc. The discs are individually adjustable on a drum mechanism, providing a choice of eight "Electric tuned" broadcast stations. The arrangement of the motor is such that its rotation will continue in the same direction regardless of the number of "Electric" tuning cycles until the tuning condenser approaches either full-out or full-in of mesh, whereupon a lever operates the reversing switch, changing the direction of rotation. A throw-out idler gear is link-coupled to the "Manual-Electric-Remote" control to disconnect the motor drive gear train when the control is thrown to "Manual" position.

Any eight stations may be chosen for "electric" tuning as follows:

1. Set range selector to "Standard Broadcast".
2. Turn "Manual-Electric-Remote" control to "Electric".
3. Turn Fidelity control counter-clockwise.
4. Press push-button #1 (left) and wait until station pointer comes to rest.
5. Turn the "Manual-Electric-Remote" control to "Manual"
6. Remove adjusting key from receptacle on top of station selector drum mechanism. (See Fig. 55).
7. Insert key in position marked "1" in station adjustment strip and push the key all the way down to properly fit the slot in disc.
8. Tune the receiver very carefully by means of the manual tuning knob and the "Magic Eye", to station chosen for number 1.
9. Remove key.
10. Turn "Manual-Electric-Remote" control to "Electric".

Button #1 is now properly set for "Electric" tuning. Proceed similarly for the other seven push-buttons, matching each station on the dial with the same number on the station adjustment strip. Repeat the above steps, but place the key respectively in positions 2, 3, 4, etc., and in each case, tune to the proper station.

Pressing the proper button will now cause the desired station to be tuned in electrically.

As stated above, the second type of motor tuning system is basically the same. However, it differs in that the gang tunes directly to the station being sought, instead of going to one end of the band and returning. Let us examine Fig. 55 to see how this is accomplished.

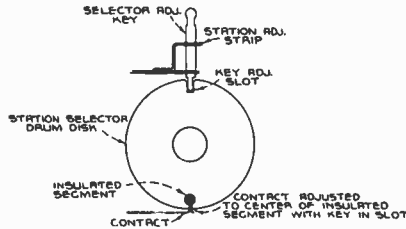

Fig. 55 Showing details of a station selector disc of a motor-driven tuning system.

In this figure you will note that the tuning motor has two separate windings, one for each direction, and one connected to each half of the tuning or selector drum. The motor circuit is completed through any one push-button, through the selector drum

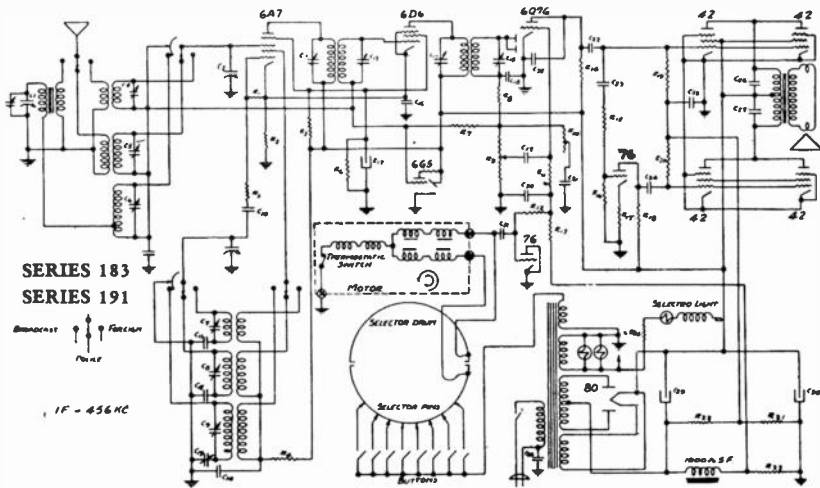

Fig. 56 A motor-driven tuning system which tunes directly to the desired station.

to one or the other motor winding, and to ground. One side of the power transformer is connected to ground and the other side is connected to the common side of the push-button circuit.

Fig. 57 shows the details of this system. The selector drum is of insulating material. On the surface of this drum are placed

two contact ribbons separated by a small space at each end. Contacts are made to this drum through the contact pins. As the drum rotates, the motor circuit is broken when the insulated portion between the two contact ribbons comes under the contact pin. Examining this circuit diagram, we see that the direction of rotation is determined by which half of the selector drum is in contact with the contact pins.

There is a third form of motor driven system in which the motor circuit is broken by means of a special cam-operated switch. This system has been used only in one or two models of receivers by one manufacturer, so we will not give any details. Its basic principle is the same as for the system just discussed, and anyone familiar with that system should experience no difficulty with the other.

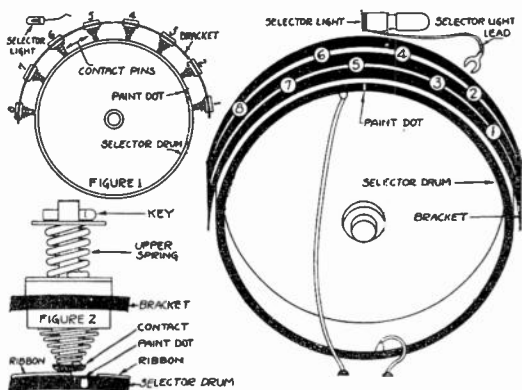

Fig. 57 Illustrating the details of the system shown in Fig. 56.

Several of the current Philco receivers employ a novel type of remote tuning which is known as the "Mystery Control". These receivers can be tuned automatically to any one of eight stations, and the volume adjusted to any level, from a remote control box. This control box is entirely self-contained, and there are no wires connected to it either from the receiver or from the power lines.

To tune in a station (once the receiver is turned on manually, and the band switch set to "Remote") it is only necessary to rotate a telephone type dial to a certain stop and then release it. Within a very short space of time, the receiver will retune itself to the station dialed at the remote control box. Soft and loud positions are also provided on the tuning dial, and the set can also be turned off from the remote control box.

The control box is, essentially, a battery-operated oscillator (See Fig. 58). It is so designed that it is normally off, and is turned on only during the dialing operation. The dial has ten positions; eight stations and loud and soft volume positions.

This dial is connected to a pulsing mechanism which times the return of the dial so that connection is made to the several dial points at regular intervals. As soon as the dial is rotated, the filament of the type 30 oscillator tube is connected to its supply. As the dial returns, the oscillator grid return is connected intermittently to the filament. This will set up an oscillation or pulse in the primary inductor for each contact on the pulser mechanism. As the dial comes to rest again, it disconnects the tube's filament supply. Thus, for any particular position dialed, a given number of pulses are radiated from the primary inductor.

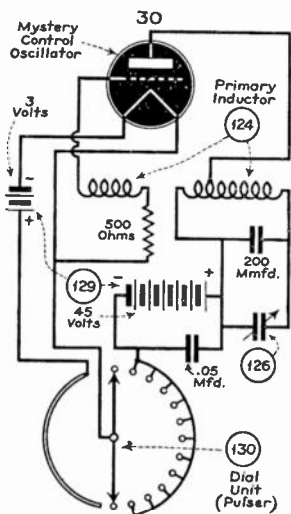

Fig. 5B The circuit of the Mystery Control Box.

To increase volume, the position at the extreme right is dialed and the end stop depressed until the desired volume level is reached. The dial returns to its original position and, as it does so, sets up two pulses in the primary inductor. Depressing the end stop keeps the oscillator functioning and maintains the signal in the primary inductor on the second pulse.

To reduce volume, the second position from the right is dialed and the end stop is depressed until the desired volume level is reached. This maintains the signal in the primary inductor on the third pulse. If the end stop is held down for a sufficiently long period, the set will turn itself off.

The control amplifier, which is located in the receiver cabinet, receives its energy from the control box through a large coil or loop located at the bottom of the receiver cabinet (secondary inductor, Fig. 59). This coil is tuned to the frequency of the oscillator in the control box by means of a trimmer located at the loop. A two-stage amplifier is used to amplify the signals received from the control box. A duo-diode is used as an AVC

tube to insure an equal signal input to the thyatron output stage over a wide variation in input signal.

The output of the control amplifier is a thyatron rectifier. This tube is similar to the ordinary gas-filled rectifier into which a grid has been placed. A rectifier passes current during the entire alternation in which the plate is positive to the cathode. A grid inserted between the plate and cathode would permit current flow only during that portion of the alternation in which the grid has the proper bias. If both grid and plate voltages are taken from the same AC source, their phase difference could be arranged so that the grid would permit current flow during the entire half of the cycle in which the plate is positive with respect to the cathode; so that no current would flow; or somewhere between these two limits.

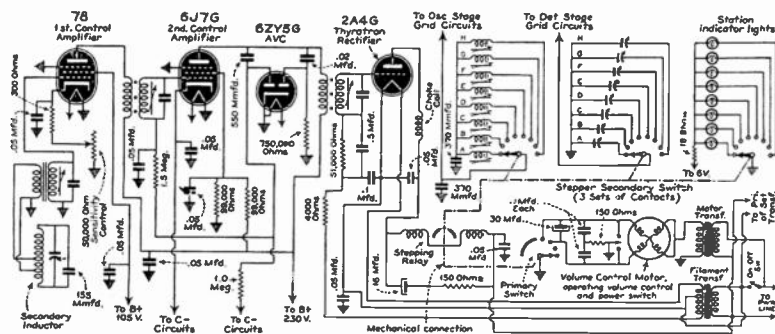

Fig. 59. The control amplifier and selecting circuit of the Mystery Control tuning system.

The grid bias for the thyatron rectifier used in the control amplifier, is taken from the secondary of the tube's filament transformer. The plate supply is taken directly from the AC lines. With the plate and grid voltages thus out of phase, no plate current will flow until the signal from the control amplifier is sufficient to overcome the bias and supply the proper potential to fire the tube. Once operation has begun, it is characteristic of this tube to continue conducting throughout the remaining portion of the AC cycle in which the plate is positive with respect to the cathode, regardless of any change in the grid voltage.

The plate current of the thyatron rectifier flows through and energizes the holding relay and permits the operation of the stepping relay as discussed below.

The stepper assembly houses a holding and a stepping relay. When the thyatron lights, the holding relay closes and the stepping relay pushes a ratchet as many times as the pulses sent out by the pulser in the control box.

There is a primary and a secondary ratchet. The stepper relay operates the primary ratchet which is connected to the pri-

mary switch. This switch controls the volume control motor and shorts the voice coil to ground in the station selection positions. A muting switch, which connects the plates of the output tube together is closed during the station-selecting operation. The set, of course, is playing during changes in volume, but is muted as the secondary ratchet returns to its home position, and climbs to the station dialed. As seen by the circuit diagram, station selection is obtained by the placing of additional capacitance in the detector circuit and additional inductance in the oscillator circuit of the receiver being tuned.

The volume control and on-off switch are motor-driven. The motor has an automatic clutch which releases and drops back as soon as the volume control is released by the stepper primary switch. This prevents over-shooting when changing volume, and stops the gear train which drives the volume control, immediately when the end stop is released on the control box. There is also a clutch in the volume control itself, so that the mechanism will not jam if the volume control lever is held down after the set is turned off. The primary switch is a single pole, double throw switch which connects the desired winding in the volume control motor to increase or decrease volume. In parallel with this switch, there is a single pole, double throw switch connected to the manual volume control.

The normal range of the "Mystery Control" is within a circle with a radius of about 25 feet from the receiver. A sensitivity control is provided in the control amplifier to fit a wide range of operating conditions.

The frequency of the remote oscillator unit is designed to operate somewhere between 350 and 400 kc. The purpose of the variety of control frequencies is to insure freedom from interference between circuits of two sets operated in close proximity to each other. A difference of at least 20 kc. is recommended for sets operating in the same room.





# Notes

*(These extra pages are provided for your use in taking special notes)*

The text of this lesson was compiled and edited by the following members of the staff:

G. L. Taylor  
President and Chief Engineer  
Midland Radio & Television Schools, Inc.

C. L. Foster  
Supt. of Instruction  
Midland Radio & Television Schools, Inc.

C. V. Curtis  
Chief Instructor  
Midland Radio & Television Schools, Inc.

R. E. Curtis  
Technical Drafting  
Midland Radio & Television Schools, Inc.

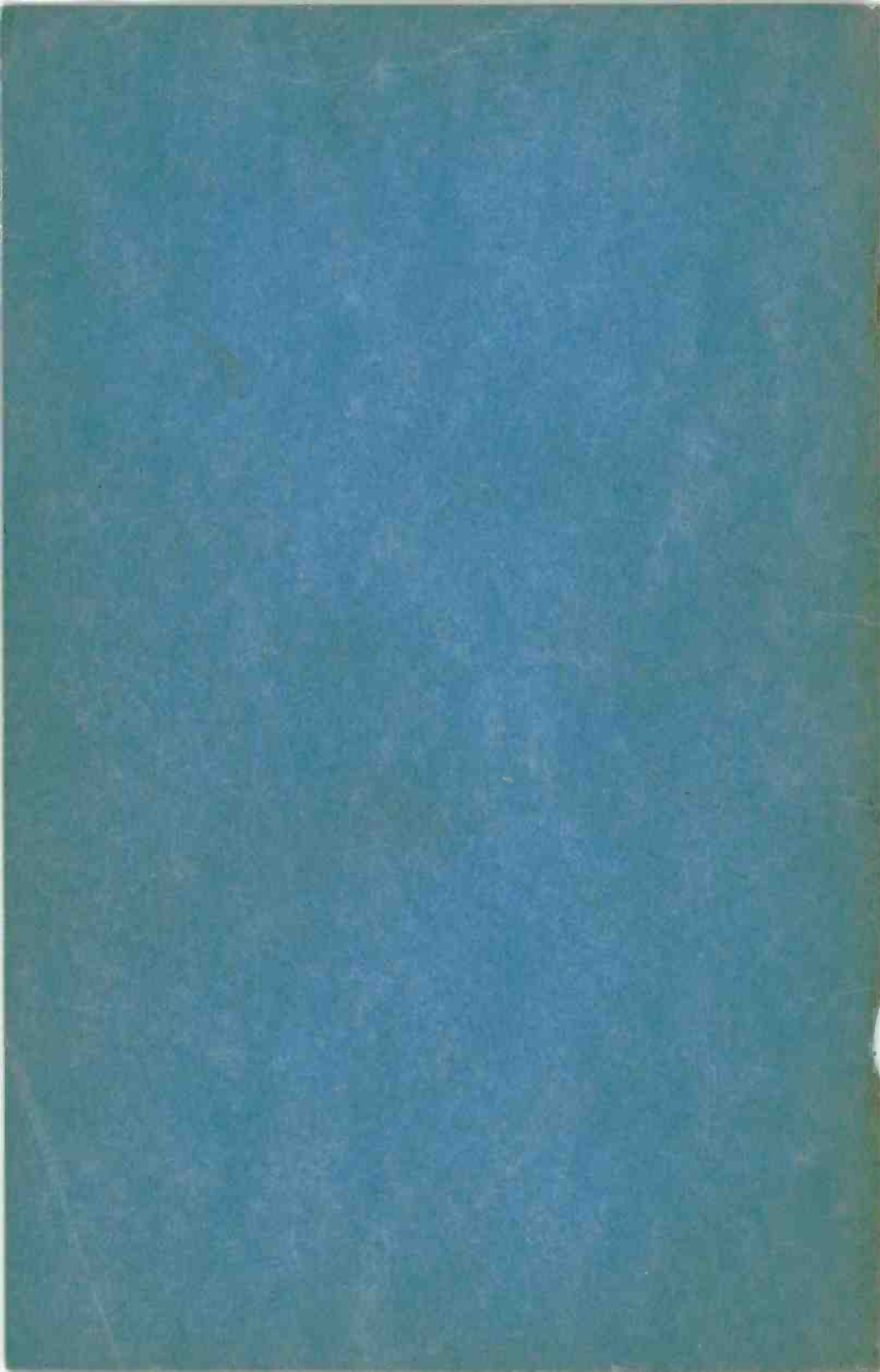



**MIDLAND RADIO  
AND TELEVISION  
SCHOOLS  
INC.**

**POWER & LIGHT BUILDING, KANSAS CITY, MISSOURI**

**UNIT  
NO.  
2**

**ALIGNMENT  
PROCEDURE**

**LESSON  
NO.  
5**



# FACTS

## .....ABOUT YOUR INDUSTRY

In 1936 there were 8,000,000 radio receivers sold to the American public. This means that there were 16 sets sold every minute, or over \$50,000 worth of receivers sold each hour of the day and night.

In 1937, it is reported, these figures jumped to 14,451,200 receivers sold, or 27 sets each minute, or over \$39,000 worth of radio receiving sets sold each hour of the day and night over the entire year!

Radio contribution to general business and industry has been pointed out by a large receiver manufacturer, in the following interesting examples:

### Electric Utilities: -

Next to flat-irons, there are more radios in American homes than any other electrical appliance. More revenue is derived from radio power than any appliance except the refrigerator.

Radios can use over \$85,000,000 worth of electricity in the United States annually. But due to inefficiency of one-third of the radios, these sets are idle part of the time. This idleness costs United States utilities \$15,000,000 each year.

There seems to be little doubt, according to these figures, that the Radio industry is well established and therefore presents unlimited possibilities to the well-trained Radioman.

Copyright 1941

By

Midland Radio & Television  
Schools, Inc.

PRINTED IN U.S.A.



KANSAS CITY, MO.

# Lesson Five

## ALIGNMENT PROCEDURE



"Those men engaged in the profession of radio servicing agree that practical experience is of great assistance in the efficient and intelligent adjusting of radio receivers. They also say that a theoretical background is indispensable.

"I have prepared this lesson with a dual purpose in mind: first, of conveying to you the necessary theoretical information on aligning a receiver with a test oscillator and an output indicator; and second, to include several items pertaining to practical application that will be of great assistance to you. A service-engineer should know his testing instruments; so in this lesson, I continue the description of equipment that has been factory and field approved."

1. INTRODUCTION. Throughout the several preceding lessons in Unit 2, we have repeatedly made mention of the various circuits throughout the receiver. During these lessons we have purposely refrained from delving into this subject; first, because we did not wish to cram a vast amount of very important information into a few pages, which would tend only to confuse the student; and, secondly, because no advantage was to be gained by instructing the student in the various alignment procedures at that time. Now, however, we feel that the student has mastered the basic fundamentals of receiver servicing, and is ready for specific instructions in alignment procedure. In the following pages of this lesson, we will discuss the various methods of alignment of different receiver circuits, using such equipment as the signal generator, vacuum tube voltmeter, frequency-modulated oscillator, and cathode ray oscilloscope.

It is a common characteristic of all receivers that, by means of one or more tuned circuits, they are able to select one signal from among many signals of different frequencies. In the superheterodyne receiver, these tuned circuits are located in the R.F. and I.F. amplifiers, while in the TRF receiver, they are in the

R.F. circuits only. When and if these tuned circuits are adjusted or aligned to the proper frequency, the receiver will operate properly and efficiently. The tuning or aligning of these various circuits in accordance with a definite procedure constitutes the alignment of a radio receiver.

2. THE OUTPUT METER. There are many different types of output meters used for alignment work, but as far as the alignment procedure is concerned, they can be divided into two different classes. One group of output indicators, which we shall consider first, measures directly the amount of audio output, while the second group functions through the AVC action in the receiver. It goes almost without saying that the latter type cannot be used on receivers which do not have AVC.

The most common type of output meter is the ordinary AC multi-range voltmeter of the 1000 ohm-per-volt type. In operation, the voltmeter is preferably connected through a .1 mfd. (or larger) blocking condenser to the plate of the output tube, and the meter set to the 30 or 50 volt range. The various adjustments are then made so as to obtain the greatest deflection on the meter, or in other words, the greatest output. Such a connection is illustrated in Fig. 1.

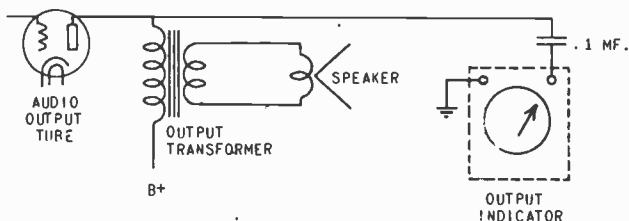

Fig. 1 Illustrating the method of connecting the output meter to the receiver.

Other arrangements which function in the same manner are those which use a low range AC voltmeter across the voice coil, or a neon tube provided with a suitable step-up transformer so that the indicator can be connected across the voice coil.

In using this type of output meter, the action of which depends upon the amount of audio output, the output of the signal generator must constantly be reduced so that the lowest possible value of input signal is used. The point here is that the use of a large input signal will tend to keep the audio output constant, because of the AVC action, and thus make it difficult to peak the trimmers accurately. Under no circumstances should the output meter be shifted to a higher range as the receiver is brought into alignment, but rather the input signal must be continually reduced. In this connection, the receiver volume control should be advanced fully so as to feed to the A.F. amplifier all the audio voltage developed in the second detector. If the audio output is not fully advanced, the input signal required to produce a reason-



able reading on the output meter may be sufficiently great so that the AVC system will be operative, and prevent proper peaking of the trimmers.

The second group of output indicators indirectly measure the output of the receiver by the amount of AVC voltage which is developed. Thus, as the receiver tuned circuits are brought into alignment, the signal voltage reaching the second detector and AVC rectifier increases, so that this rectified AVC voltage can be used as an indication of the amount of output.

A milliammeter (0-10 ma.) connected in the plate circuit of one of the controlled tubes can be used as an output indicator. This is possible because the amount of AVC voltage increases as the tuned circuits are brought into alignment; and, since this AVC voltage is applied to the controlled tubes in the form of a negative grid bias, it follows that the plate current of the controlled tubes has its lowest value when the trimmers are properly peaked.

A variation of this same method is to use a high-resistance voltmeter across the cathode resistor of one of the controlled tubes. Clearly, the voltage drop across this resistor has its lowest value when the trimmers are properly peaked because the plate current is then at a minimum. It may be pointed out that the tendency in the newer circuit designs is to dispense with these cathode resistors and to ground the cathodes directly, so that it is not possible to use this method in all cases.

With the AVC type of indicator, it is not necessary to keep the input signal at a low value, as is the case with the straight audio output type of indicator. In fact, it is desirable to keep the input signal at a reasonably large value so that the AVC system will function and make it possible to obtain an appreciable deflection on the output indicator. At the same time, too strong a signal should not be used, as this will overload the receiver and make it impossible to peak the trimmers sharply in the overloaded circuits. A modulated signal is not required, since all AVC circuits used in broadcast receivers function on the basis of the carrier strength, and are independent of the degree of modulation.

The type of output meter used is of little importance, provided it is kept in mind that with the straight audio type of output meter, the input signal to the set must be kept at a low value; and that with the AVC type of indicator, the input signal must be sufficiently high to render the AVC circuit operative, but not high enough to overload the receiver.

3. THE TUNED RADIO FREQUENCY RECEIVER. Due to its comparative simplicity, the alignment of a TRF receiver will be considered first. There are two types of TRF receivers; those which use a neutralizing system, and those which do not use such a system. The reason for separating these two types of TRF receivers is that in those receivers which utilize neutralizing systems, the alignment of the tuned circuits is secondary to the neutralizing oper-

ation, while naturally such is not the case in those receivers in which a neutralizing system is not used. In order to follow a logical sequence, we will consider first those receivers which do not require neutralization.

As far as alignment procedure is concerned, such receivers involve two types of trimmers or alignment adjustments. One of these is the type which has regular trimmers in shunt with the main tuning condenser. The other type is that which employs tuning condensers with slotted end plates, the segments of these end plates forming the trimmers. As a rule, receivers equipped with standard trimmers in parallel with the tuning gang are aligned at 1400 kc., while those equipped with segmented end plates are aligned at four or five different frequencies corresponding to those frequencies at which each segment is fully meshed.

The first step in the actual alignment procedure is to place the receiver in operation, with all trimmers accessible and all shields in place. It is assumed that all operating voltages of the receiver have been checked and found correct. Any faulty operation of the receiver, such as lack of sensitivity and selectivity, can be due to poor alignment of the various tuned circuits.

Some trimmers will require a screwdriver and others a wrench for adjustment. In either case, it is preferable that the alignment tool be entirely of bakelite or some non-metallic material. An ordinary metal screwdriver or wrench is not suitable because the metal will detune the circuit. Thus, the first step in the alignment process is to obtain the correct alignment tool.

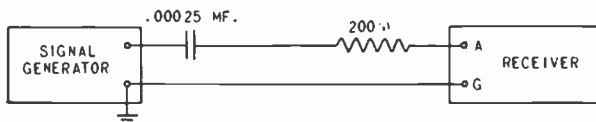
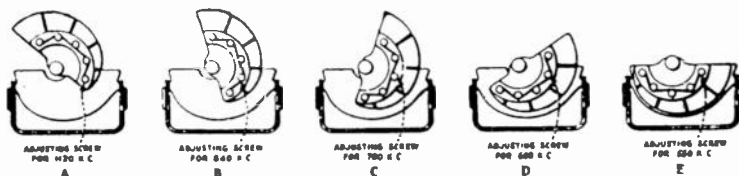

Fig. 2 Showing how the signal generator is connected through a dummy antenna to the receiver.

The signal generator is connected to the receiver antenna post through a dummy antenna, consisting of a .00025 mfd. condenser and a 200 ohm resistor, as shown in Fig. 2. The dial position must next be checked. Turn the condenser shaft until the tuning condenser plates are fully meshed. Generally, a reference mark is provided by the set manufacturer for the purpose of indicating the position which represents a fully meshed or fully open condenser. Set the condenser so that the reference mark on the dial coincides with the reference mark on the chassis. Inspection will readily determine whether the reference mark is for the condenser plates fully unmeshed or fully meshed. Where the cabinet escutcheon constitutes the dial pointer, a temporary pointer should be provided and centered, so that its position corresponds to that of the escutcheon. A piece of wire, properly mounted and bent, will serve the purpose well.

Tune the receiver to the frequency as specified by the manufacturer. This is usually 1400 kc. The signal generator is now tuned to 1400 kc. and with the volume control of the receiver set to full volume, adjust the signal generator to a point where the output meter is about half-scale. Now adjust the various trimmers for maximum reading on the output meter. In every case, the trimmers should be adjusted from the detector toward the antenna. As the alignment proceeds, it will probably be necessary to reduce the signal strength from the signal generator in order to keep the output meter at approximately half-scale. In no case should the volume control on the receiver be adjusted. After all adjustments have been completed, they should be repeated, as in many instances circuit reaction will cause a very slight change in previous adjustments.

In those receivers in which no trimmers are used, it will be found that the end plates of the tuning condenser are slotted, usually in four places, giving five segments. These segments can be adjusted by means of screws provided for that purpose or by bending the segments manually. Whichever is required, the procedure is the same as for standard trimmers.



Courtesy RCA Mfg. Co.

Fig. 3 Illustrating how the end plates of a tuning condenser are slotted to provide adjustment throughout the band.

The next step is to check the alignment of the receiver at the other frequencies throughout the band. This is accomplished by advancing the tuning condenser until each segment of the slotted end plate is just meshed. Each segment is then adjusted at that position for maximum output on the output meter. After the complete band has been covered in this manner, it is wise to repeat the complete alignment, as the bending of adjacent segments will affect the alignment in the other segments slightly. An example of a condenser with slotted end plates is shown in Fig. 3. Adjusting screws for trimming the plates of the tuning condenser are shown. The lines between the individual screws represent a spring wire which acts as a keeper and keeps the screws from turning when the receiver is operating and producing a large amount of vibration.

4. NEUTRALIZATION. Since the screen grid tube was introduced several years ago, the necessity for neutralization of radio receivers has been removed. However, as there are still many of these early receivers in operation, we feel it advisable to devote some space to a short outline on this subject.

When a triode is used as an amplifier, the capacity between

the grid and plate of the tube becomes a very important factor in the operation of the receiver, because this capacity serves as a means of transferring energy from the plate to the grid circuit. This transfer of energy or feedback is usually sufficient to cause oscillation. Many receivers manufactured before the introduction of screen grid tubes actually fed a portion of the plate signal back to the grid in order to cancel the voltage induced on the grid through the grid-plate capacitance. This process of feedback is called neutralization.

Although there are several different methods of accomplishing neutralization the ultimate result is the same; that is, a balance between the voltage induced on the grid through the grid-plate capacitance, and the feed-back voltage. As far as we are concerned the important item is that the neutralizing technique is the same for substantially all neutralizing systems.

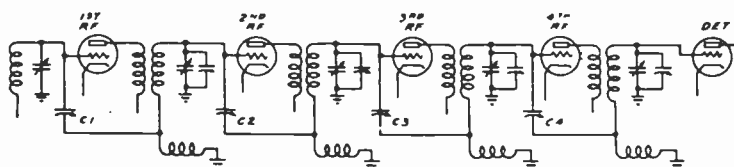

Fig. 4 Schematic of a TRF receiver using neutralization.

In Fig. 4 is shown a partial schematic of a typical TRF receiver with the neutralizing condensers indicated as C1, C2, C3, and C4; there being four R.F. stages and a neutralizing condenser for each stage. Each stage is individually neutralized by its own neutralizing condenser. The neutralizing operation consists of adjusting the capacity of the neutralizing condenser to balance out the coupling introduced through the grid-plate capacity. This is most easily effected by the use of a dummy tube; that is, a tube similar in every way to the tubes used in the R.F. amplifier, but with one heater or filament prong removed. The dummy tube is inserted in the stage being neutralized in place of the normal tube for that socket. Since the heater or filament circuit of the dummy tube is open, the tube cannot amplify, and so if there is any signal passed through this stage, it must be fed through the grid-plate capacity. When the neutralization is complete, the signal will be passed through both the grid-plate capacity and the neutralizing capacity and will cancel in the plate circuit, there being no net signal to be transferred through the following stages to the output meter. The process of neutralization is as follows.

The signal generator and receiver are placed in operation and tuned to about 1000 kc. The signal generator is adjusted to give a good reading on the output meter. To neutralize the fourth R.F. stage (Fig. 4) the fourth R.F. tube is replaced by the dummy tube. It will now be necessary to increase the output of the signal generator and, at the same time, the neutralizing condenser C4 is adjusted for minimum output. To keep the receiver tuned to the

signal frequency, it is desirable to readjust the tuning control of the receiver frequently as the neutralization progresses. This is required because there is some reaction between the tuning and the neutralizing adjustments. Having adjusted C4, the tube is replaced and the dummy tube inserted in the third R.F. socket. In the same way, C3 is adjusted for minimum output. Similarly, the dummy tube is, in turn, inserted in the second and first R.F. sockets and C2 and C1, respectively, are adjusted. It is to be understood that a modulated signal is being used throughout the above procedure and that the volume control is at maximum.

In general, a frequency in the neighborhood of 1000 kc. is satisfactory for neutralization and provides adequate neutralization throughout the band. If the receiver, when neutralized at 1000 kc., shows a tendency to oscillate at the high-frequency end of the band, then neutralization should be carried out at a higher frequency, say about 1200 kc. On the other hand, if the receiver is stable at the high-frequency end but oscillates at about 600 kc. the low-frequency end, then the receiver should be neutralized at about 800 kc. In every case, it is important to check the stability of the receiver throughout the entire band.

If the receiver uses tube shields, it is important that they be in place during neutralization. Repetition of the entire procedure is advisable in those cases where an appreciable change in the neutralizing condensers is made. With the neutralization complete, the receiver can now be aligned in accordance with the instructions given in the preceding paragraphs. Should the receiver show a tendency toward instability after alignment, the neutralizing adjustments should be repeated. It should be pointed out that the neutralization is effective only insofar as instability and oscillation are caused by feedback through the grid-plate capacity of the tube. If the feedback is due to other causes, such as inadequate shielding, improper voltages, or open by-pass condensers, it will be impossible to neutralize the receiver properly until these defects are corrected.

##### 5. GENERAL CONSIDERATIONS OF THE SUPERHETERODYNE RECEIVER.

In considering the alignment of superheterodyne receivers, it is convenient to look upon the superheterodyne as consisting of several more or less distinct units (See Fig. 5). Thus, the signal voltages in the antenna circuit are fed to the R.F. amplifier section of the receiver; it is the function of this part of the receiver to select the desired signal from among all the other signal voltages present in the antenna circuit and to amplify the wanted signal at the same time. In order to perform both of these functions efficiently, it is absolutely essential that the tuned circuits present in the R.F. unit be tuned accurately to the signal.

As far as the detector-oscillator sections of the receiver are concerned, the oscillator tuned circuit must be adjusted so that, throughout the entire range, the frequency generated by the oscillator is higher (or in some cases, lower) than the signal

frequency by an amount equal to the intermediate frequency. This oscillator voltage is fed to the first detector circuit where it is mixed with the signal voltage and produces a frequency equal to the resonant frequency of the I.F. amplifier, which is commonly designated as the I.F. peak.

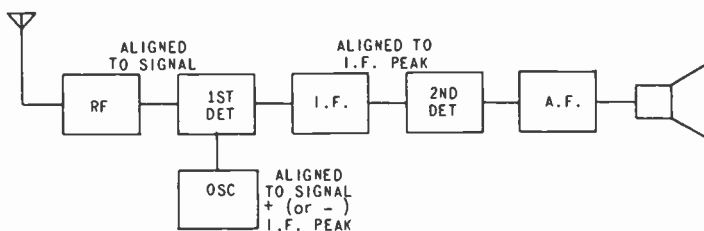

Fig.5 A block diagram of a superheterodyne receiver showing the frequencies to which the various stages are aligned.

The original signal is thus converted to a signal of intermediate frequency which contains exactly the same modulation as the original signal. It is the function of the I.F. amplifier to take this signal, amplify it, and at the same time be sufficiently selective so that it will attenuate other signals which are close in frequency to the desired signal. In order to perform both these functions, the tuned circuits in the I.F. amplifier must be carefully tuned or aligned to the intermediate frequency for which the set was designed. The greatly amplified signal voltage is then fed to the second detector where the audio voltage is produced, and this audio voltage is then amplified by the audio amplifier and reproduced by the speaker.

The above description is not intended to be very elaborate, but rather is more or less in the nature of a rapid review of superheterodyne operation.

Whether or not the faulty operation of a receiver is due to poor alignment or to some other cause is occasionally a difficult question to answer. In some cases it is necessary to carry out a part of the alignment procedure before this can be definitely determined. As a general rule, however, it may be stated that in entirely too many cases there is a tendency to blame poor receiver operation upon the alignment and to upset a perfectly good alignment without first having investigated other obvious defects. This tendency to turn the trimmers unnecessarily and upset the alignment in a complicated multi-band receiver is one that should be guarded against, and a preliminary examination of the receiver should be made to be certain that poor alignment is the cause of the trouble.

An incorrect alignment condition in a receiver is generally accompanied by one or more of the following conditions or symptoms: low sensitivity, poor selectivity, faulty dial calibration, and distortion. These conditions may occur on one or more of the bands, and may be present to various degrees, depending upon which

tuned circuits are out of alignment and the extent to which they are out of adjustment.

A few moments spent in analyzing the trouble will often save a great deal of time. For example, suppose that a receiver shows a fairly low sensitivity on all the bands. Under these circumstances an investigation of the I.F. amplifier alignment is in order, because misalignment of this part of the receiver would drop the sensitivity uniformly on all bands. On the other hand, a misalignment of the R.F. trimmers would affect the alignment on only one band rather than on all bands. While it is perfectly possible for all the alignment adjustments on all the bands to be out, the more probable condition is that the I.F. amplifier needs realignment, and hence this is the one which should be investigated first.

On the other hand, suppose we take the case in which a receiver operates on all bands, but shows low sensitivity and poor dial calibration at the low-frequency end of one of the bands. This immediately should indicate to the serviceman that the trouble is due to misalignment of the low frequency oscillator trimmer on that band, since it is this trimmer which controls the calibration and sensitivity over the low-frequency end of the band.

It may be noted here that low sensitivity is a fault which can be caused by many factors other than misalignment. Therefore, the fact that the sensitivity of the receiver is low is not sufficient in itself to throw suspicion upon the alignment. However, when a condition of low sensitivity is accompanied with distortion and poor calibration, then it is probable that the receiver needs realignment both to raise the sensitivity and to restore the dial calibration.

If, as often occurs in practice, an all-wave receiver shows normal sensitivity and operation on one or more bands, and fails to perform properly on the other bands, then the first step should be to check the adjustments common to that band only. In other words, it is quite unnecessary to check the alignment of the I.F. amplifier, since the fact that the receiver performs properly on at least one band is direct evidence that the I.F. amplifier is operating properly.

There are a number of different factors which operate to bring about the necessity for realignment at more or less frequent intervals. Perhaps the factor which is responsible for more realignment jobs than any other is the change in the characteristics of the components associated with the tuned circuits of the receiver. Due to vibration, the movement of parts, the effects of humidity, temperature, and age, the capacity and inductance associated with these tuned circuits change their values, and the tuned circuits go out of alignment. In recent years there has been considerable improvement in the design and manufacture of the components of tuned circuits, so that this change in capacity and inductance over periods of time is being held to a minimum. Among the developments in this connection have been the perfection of

compact air-dielectric trimmers of various types, the perfection of radio frequency iron-core materials, and improved methods of construction and assembly which tend to make for permanence of adjustment.

Aside from the changes in the tuned circuit itself, there are a number of other factors which operate to cause the need for realignment. Among these can be mentioned the movement of R.F. and I.F. wiring, since the movement of these leads changes the relative capacities and inductances associated with the tuned circuits. Of special importance is the need for avoiding changes in the relative positions of wiring associated with the high frequency bands, and especially the ultra-high frequency band, if the receiver is equipped with one. On the latter band, a slight change in the position of the wiring may cause the entire band to be inoperative, since the leads constitute a large part of the inductance and capacitance of the tuned circuits. Particular mention in this connection must be made of the importance of using replacement parts where replacement of resistors, condensers, and other parts becomes necessary in or near the R.F. unit. The use of a part which has the same electrical characteristics, but which has different physical characteristics or size will sometimes throw the receiver out of alignment, and in other cases may even cause instability and oscillation.

As a general rule, the replacement of tubes with new tubes of the same type will not often influence the alignment of a receiver to the extent that a noticeable change in performance will be evident. However, it should be observed that where a receiver is originally equipped with octal base glass tubes, these tubes should not be replaced by the corresponding all-metal tubes, unless the receiver is to be realigned. The reason for this condition is that the capacities of metal tubes are different from those of glass tubes, and this difference in capacity appears across the several tuned circuits and hence causes incorrect alignment.

When the serviceman has satisfied himself that the performance of the set can be improved by realignment, the first step is to consult the manufacturer's instructions relative to the alignment of the receiver in question. Reference to such data is necessary and desirable in order to determine the recommended procedure, the alignment frequencies, and the location of the various trimmers. The importance of reference to the manufacturer's data cannot be overestimated; in the last analysis, the proper procedure depends upon the design of the receiver, and the manufacturer is best qualified to state the special steps to be followed in aligning his set.

As a general rule, the alignment procedure for all receivers should be carried out under conditions which simulate as much as possible the conditions under which the receiver operates. This means, for instance, that if any of the coils happen to be exposed, then the alignment should not be carried out with these coils close to a metal-top work bench which will change the



inductances of the exposed coils; it means, if the receiver has a metal bottom, that this bottom should be in place before the alignment adjustments are changed; it means that the receiver chassis should be grounded, that all the tube shields should be in place, and that the line voltage should be set at the average value which is encountered in the customer's home (important for AFC equipped receivers); it means that the receiver should be allowed to reach its normal operating temperature by having been in operation for at least 15 minutes before the final alignment adjustments are made.

It is frequently noticed that the reading of the output meter will drop when the alignment tool is removed from the adjusting screw or nut. This is particularly true when the alignment condensers are of the spring brass mica compression type. The weight of the alignment tool on the spring brass may increase the capacity of the trimmer slightly, and then when the tool is removed, the small resultant change in capacity causes the alignment to be imperfect, with a resultant drop in the output.

Experience is of great assistance in minimizing error from this source. It will be found, if the trimmer is first adjusted for maximum output and the setting then increased slightly clockwise, that the output will rise to its previous maximum value as the tool is withdrawn. If the correct adjustment is not obtained the first time, the adjustment should be repeated until the output rises to approximately the same value, with the tool removed, which was obtained when the trimmer was adjusted for maximum output with the tool on the trimmer.

A trimmer should never be left loose in its minimum-capacity position; if necessary, the end plate should be bent so that the plate rests firmly against the nut. When the alignment is completed, it is sometimes advisable to seal the trimmer or tighten the lock nut as the case may be. In carrying out this operation, care should be taken to see that there is no change in the output meter reading, as the trimmer is being sealed or locked.

It is general practice to use a shielded lead for connecting the signal generator to the appropriate point in the receiver, in order to avoid coupling the output of the generator to other points in the receiver. In this same connection, it is advisable to keep this lead as far as possible from the grid leads of adjacent tubes, to minimize further the possibility of stray coupling.

In the early stages of the alignment procedure, where the signal generator is almost invariably coupled to the grid of one of the I.F. or R.F. tubes, it is considered good practice to couple the output lead of the signal generator directly to the grid cap and to leave the receiver grid lead connected. In this way, the grid of the tube is returned to the proper DC potential and the voltage distribution in the receiver is not affected. This is of importance where the receiver design is such that the grid is returned to a point in the receiver different from ground, and is of special importance in the case of the newer receivers,

where the minimum bias voltage for the R.F. and I.F. tubes is often fed through the grid rather than through the cathode circuit.

To avoid short-circuiting the DC grid path in the receiver, the output terminal of the signal generator should contain a blocking condenser, the capacity of which is of the order of .01 mfd. In many signal generators this condenser is contained internally, but there are a considerable number of signal generators which do not incorporate such a blocking condenser; in the latter cases, the .01 mfd. condenser must be connected externally. This condenser is not to be confused with the 200 mfd. condenser which is used as a dummy antenna in aligning the antenna stage of receivers for the broadcast range. The latter condenser is designed to simulate the characteristics of the average broadcast antenna and should be connected at the receiver end of the signal generator coupling lead rather than at the signal generator end.

6. I.F. ALIGNMENT WITH OUTPUT METER. The first step in the alignment of any superheterodyne receiver is the alignment of the I.F. amplifier. Regardless of the type of superheterodyne or the frequency range covered, the I.F. transformers should be adjusted independently of any tuned circuits in other parts of the receiver. Under no circumstances should the alignment of the I.F. amplifier be made secondary to the R.F. or oscillator adjustment, and it should be understood that whenever the alignment of the I.F. amplifier is changed, the alignment of the R.F. section of the receiver is affected.

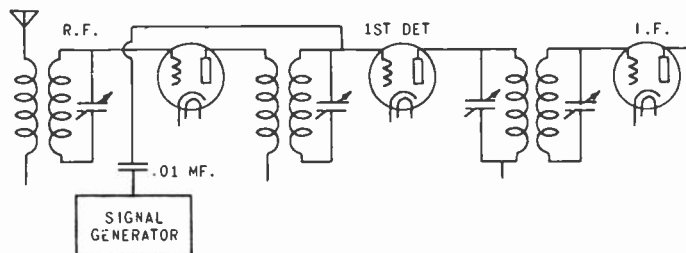

Fig. 6 The proper method of connecting the signal generator for I.F. alignment.

To align the I.F. amplifier, the signal generator should be coupled to the grid of the first detector through a .01 mfd. coupling condenser in the manner shown in Fig. 6. Harmonics of the signal generator can be prevented from feeding into the R.F. amplifier and causing miscellaneous beats by shorting the oscillator section of the variable condenser with a short clip lead. This method of stopping the oscillator is general in that it is equally applicable when a separate oscillator tube is used, or when a combined oscillator-first detector tube is employed. It is always desirable to have the waveband switch in the broadcast band position when aligning the I.F. amplifier, in order to avoid the

short-circuiting effect of the first detector grid coil. If the range switch is left in one of the short wave positions, the impedance of the detector coil is often sufficiently small so that it is impossible to drive a signal through to the second detector of the receiver.

If, when this precaution has been taken, the receiver is so badly out of alignment that it is impossible to get a signal through, the signal generator lead should be shifted to the grid of the last I.F. tube. After the trimmers associated with this stage have been aligned, it will be possible to drive a signal through from the grid of the preceding stage; assuming, of course, that the stage is not inoperative for some reason other than incorrect alignment.

A receiver which uses I.F. amplifiers having a variable selectivity (or fidelity) control should be aligned with the control in the maximum selectivity position. In this way the interaction between the primary and secondary windings, which ordinarily makes a special procedure necessary, is avoided. After the I.F. alignment is completed with the selectivity control in the sharp-selectivity position, the overall I.F. alignment should be checked with the control in the broad-selectivity position. The variation in the output meter indication should be symmetrical and the two peaks which are obtained as the signal generator frequency is varied through about 10 kc. on either side of the I.F. peak, should have the same height.

In a number of high fidelity receivers the last I.F. transformer is of the overcoupled type, and this coupling remains fixed regardless of the setting of the selectivity control. In these cases, and in fact in all cases of overcoupled transformers, it is desirable that each overcoupled transformer be aligned separately. To carry out the alignment of an overcoupled transformer, the signal generator should be connected to the grid of the tube preceding the transformer, and the primary and secondary windings adjusted for a symmetrical output for two peaks of equal height, spaced equal distances from each side of the I.F. peak.

It is characteristic of overcoupled transformers of this type that the primary and secondary windings react on each other, so that the conventional method of aligning the two windings for maximum output cannot be used. One method of overcoming the reaction between the two windings is to shunt a 20,000 ohm,  $\frac{1}{4}$ -watt resistor in series with a .01 mfd. condenser across one of the windings, while the other is being aligned; the principle of operation is to damp one of the tuned circuits of the transformer so that it will not react on the other, and thus make it possible to peak the circuit. After the one winding has been adjusted, the resistor-condenser combination should be removed, and it will then be possible to peak the other winding for maximum output. This completes the alignment of the transformer.

Where the I.F. amplifier uses a mechanical system of variable coupling to obtain variable selectivity, the I.F. amplifier should be aligned in the conventional manner with the coupling in the

minimum coupling position; that is, the maximum selectivity position. If this is properly done, then the alignment will be correct and will provide a symmetrical curve for all positions of the selectivity control.

In a considerable number of receivers, two I.F. channels are provided, the one channel feeding the second detector, and the other channel feeding the AVC rectifier. In cases of this sort, the alignment of the I.F. amplifier requires that each channel be separately aligned in the conventional manner. So far as the regular signal channel is concerned, the I.F. amplifier can be aligned with the output meter connected to the plate of the output tube, and the trimmers in this channel adjusted for maximum output. The alignment of the AVC channel, which in most cases of this type, means the alignment of only one additional transformer, is most easily accomplished by leaving the output meter connected to the plate of the audio tube, and adjusting the trimmers in the AVC channel for minimum output. A fairly strong signal should be used for this adjustment, since the action depends upon the signal being sufficiently strong so that the AVC action will be brought into play. As the trimmers in the AVC channel are brought into resonance, the amount of AVC voltage produced at the AVC rectifier is thus increased; the proper peak is obtained when the maximum AVC voltage is developed; that is, when the audio output drops to a minimum.

In a number of receivers, a separate channel is used to supply the tuning indicator circuit, and in these cases the alignment of the tuning indicator is readily made after the regular I.F. channel is aligned. To carry out the alignment of this circuit, the tuned circuits associated with this indicator should be adjusted so that the greatest deflection or indication is obtained on the tuning indicator. Since these circuits are invariably sharp-selectivity circuits, only one peak is obtained, and there is no difficulty in carrying out this adjustment.

In receivers with more than one I.F. stage, difficulty may be experienced as a result of regeneration which occurs because of feedback to the input circuit of the I.F. amplifier; in extreme cases of this type the I.F. amplifier may break into oscillation, so that correct alignment is impossible. This effect can be minimized by using a shielded coupling lead to the signal generator and by using a signal generator with a low output impedance, so that the amount of stray voltage fed back to the input of the I.F. amplifier is kept to a minimum.

Following the alignment of the I.F. amplifier, it is a general policy to check the position of the dial pointer with respect to the condenser gang setting. The procedure for doing this varies for different dials, but when it appears that the dial needs adjustment, it will often be found that there is an index mark at the low-frequency end of the dial. In such cases, the adjustment should be made so that the dial pointer coincides with this mark when the condenser plates are fully meshed.

If the receiver is provided with an I.F. wave trap, it should be adjusted after the I.F. amplifier has been aligned. It is best to make this adjustment before the R.F. alignment is carried out, because in some circuits there is interaction between the wave trap adjustment and the R.F. alignment. With the signal generator connected to the antenna post and the frequency set at the I.F. peak, the output of the signal generator should be advanced all the way. The wave trap adjustment should be made for minimum output, and not maximum output, as are practically all other alignment adjustments.

Ordinarily it will not be necessary to repeat this adjustment. However, if after the receiver is installed, interference in the neighborhood of the intermediate frequency is present, then the wave trap should be adjusted so as to minimize this interference. This adjustment should be made while the receiver is connected to the antenna, and tuned to that point on the dial where the interference is most pronounced. With the receiver in this condition and the volume control advanced fully, the wave trap trimmer should be readjusted for minimum output. This is the correct adjustment even though the wave trap is resonated to a frequency which is slightly different from the I.F. peak.

In certain localities, it has been found advisable to change the I.F. peak of some receivers, particularly those which have very little R.F. pre-selection. In such cases, the I.F. peak may be changed by as much as is found necessary in order to find a frequency which is near the recommended I.F. peak, but which is farthest away from the interference. The complete realignment of the receiver is necessary, including the adjustment of the R.F. and oscillator circuits to correspond with the new I.F. peak. In particular, the wave trap should be aligned to minimize the interference, and not to the new I.F. peak.

7. ALIGNING THE OSCILLATOR AND R.F. CIRCUITS. By far the most important of the adjustments which follow the alignment of the I.F. amplifier are those which are located in the oscillator circuit. The adjustment of the oscillator trimmers is of extreme importance because the frequency of the oscillator determines whether or not the difference frequency produced in the first detector will be the correct I.F. peak. Improper adjustment of the oscillator trimmers thus prevents the signal from getting through the I.F. amplifier "on the nose", and thus impairs the selectivity, and the dial calibration to a marked extent. The other radio frequency adjustments, while they are important, affect the performance to a much smaller degree. In particular, the dial calibration is controlled almost entirely by the oscillator adjustments, and is only slightly affected by the adjustment of the R.F. trimmers.

As a general rule, the adjustment of the high-frequency oscillator trimmer follows the alignment of the I.F. amplifier. To make this adjustment, the signal generator should be connected to the antenna post of the receiver, and both the signal generator

and the dial of the receiver set to the same frequency near the high-frequency end of the band being aligned. The frequency specified in the alignment data given in Manufacturer's Service Notes should be used for making this adjustment. If the receiver is out of alignment appreciably, it will be impossible to pick up the signal at the correct point on the dial; but it will be found that the signal comes in somewhere near the required point.

If, for example, the signal generator is set at 1400 kc. and the signal appears at 1300 kc. on the receiver dial, then the high-frequency oscillator trimmer should be turned clockwise slowly (increasing the capacity) until it is possible to hear the signal with the dial set at the proper frequency, which is 1400 kc. in the example chosen. The trimmer should now be adjusted accurately for maximum output with both the signal generator and the receiver dial set at the same frequency. Following this adjustment, the R.F. and antenna trimmers should be adjusted for maximum output.

Just as the high-frequency oscillator trimmer determines the performance of the receiver over the high-frequency portion of the band, so the low-frequency oscillator trimmer determines the performance over the low-frequency end of the band. The method of making this adjustment is different from the usual manner in which trimmers are peaked for maximum output, in that a procedure commonly designated as "rocking" must be used.

This rocking adjustment is carried out in the following manner. The signal generator and receiver are tuned to the point near the low-frequency end of the band which is specified in the alignment data. To make this discussion more definite and easier to follow, we shall assume that the adjustment is being carried out for the broadcast band, in which case the signal generator would be set at 600 kc. The receiver should be tuned for maximum output, and in general the dial reading will not be exactly 600 kc., but may be off as much as 10 or more kc. on either side. Whatever the dial reading; even if it is exactly 600 kc., the next step should be to change the setting of the low-frequency oscillator adjustment slightly and then to tune the receiver for maximum output. If this procedure increases the output, the setting of the oscillator trimmer should be changed a small additional amount in the same direction, and the receiver again tuned for maximum output. On the other hand, if the movement of the oscillator trimmer is in this same direction and the readjustment of the tuning control reduces the output, then a slight variation of the trimmer in the reverse direction should be tried, and the receiver tuning control should be readjusted for maximum output. This procedure of alternately adjusting the oscillator trimmer and the tuning control should be continued until no further increase in output can be obtained; that is, until the displacement of the oscillator trimmer in both the clockwise and counter-clockwise directions and the accompanying rotation of the tuning control for greatest output is accompanied by a reduction in the output. The object of this procedure is to arrive at that adjustment wherein

the R.F. circuits are tuned to the signal, and the oscillator frequency is higher than the signal frequency by the amount of the I.F. peak, so that the greatest receiver sensitivity is obtained. It should be noted that in general the dial calibration will not be exactly correct, but that nevertheless this is the best possible adjustment.

Upon completion of this rocking adjustment near the low-frequency end of the band, the adjustments near the high-frequency end should be repeated. Unless the alignment adjustments were initially very far off, it will not be necessary to again repeat the adjustments at the low-frequency end of the band.

With receivers which employ bandpass R.F. circuits sufficiently broad to pass the wide sidebands required for high-fidelity reception, the application of this conventional rocking procedure will not produce any sharply defined best setting of the low-frequency oscillator trimmer. The R.F. circuits may be broad enough so that the optimum setting of the oscillator trimmer for any dial setting within a range of about 15 kc. will produce essentially the same output. In cases of this sort, the frequency readings of the dial should be noted at the two extreme positions where the output begins to fall off. The dial should then be set half way between these two positions, and the oscillator trimmer should be aligned for maximum output.

For example, if for a particular receiver, with the signal generator set at 600 kc., substantially the same output can be obtained over the range from 580 kc. to 610 kc. (with suitable adjustments of the low-frequency oscillator trimmer over this range), then the dial should be set half-way between these two frequencies (595 kc.) and the oscillator trimmer adjusted for maximum output with the dial set in this position and the signal generator still set at 600 kc. While the above procedure is recommended as a good general practice to follow in the case of high-fidelity receivers, it is to be understood that the manufacturer's instructions, where available, should be followed in preference to this general procedure.

8. ALIGNMENT OF SHORT-WAVE BANDS. The alignment of a receiver on the high-frequency or short-wave bands follows the same general procedure for the broadcast band, but is somewhat more involved and requires more experience and skill. Primarily, the reason for the greater difficulty of alignment of the short-wave bands is that there are two frequencies of the oscillator; that is, two settings of the oscillator trimmer, for which the output meter will indicate a maximum reading. Despite the fact that both of these peaks are equal, only one of them is correct, and only this one will give good receiver performance over the entire band. On the broadcast band; in fact, on all bands, and in every superheterodyne, there are two adjustments of the oscillator frequency that will give identical performance on a particular dial setting; however, on the low-frequency bands, only one of these oscillator frequencies is within the range of the oscillator trimmer. This

frequency is, of course, the correct frequency for that particular band; and consequently, there is no possibility of an error in alignment. Let us take an example to make this particular statement a little more clear. Let us assume that we have a receiver operating with an I.F. peak of 470 kc. If the receiver is tuned to 1000 kc., the oscillator frequency will be 1470 kc. The other frequency of the oscillator which will give an I.F. peak of 470 kc. is  $1000 - 470$ , or 530 kc. This latter frequency is said to be the image frequency of the 1470 kc. oscillator frequency, because it also is separated from the signal frequency by the same frequency difference. In this case, there would be no difficulty in alignment because it would be impossible to obtain a frequency of both 1470 kc. and 530 kc. using the same trimmer. Now let us assume that the receiver is tuned to 20,000 kc., in which case the oscillator frequency would be  $20,000 + 470$ , or 20,470 kc. The image frequency in this case will be  $19,530$  kc. ( $20,000 - 470$ ). Obviously, these two frequencies are so close together that they can both be obtained with the same oscillator trimmer. The correct frequency (the one which is higher) is obtained with minimum capacity or with the trimmer nearly all the way out.

The correct oscillator frequency of course depends upon the design of the receiver. Until recently, the higher oscillator frequency was almost invariably the correct one. Some of the later receivers, however, make use of the lower oscillator frequency on one or more of the high-frequency bands. Where no definite information is available, it is recommended that the following procedure be used.

The first step in determining whether the image frequency of the oscillator should be above or below the signal frequency is to shift the signal generator and dial to the low-frequency end of the band and see if it is possible to obtain two settings of the oscillator trimmer which will give the same output. In the event that there is only one setting of the oscillator trimmer at the end of the band, then the following procedure will determine whether the oscillator frequency is higher or lower than the signal frequency for the particular band being aligned. Again, a concrete example with a receiver using an I.F. of 470 kc. will show exactly the procedure to be followed.

If we assume that only one oscillator setting is obtained when an 8000 kc. signal is fed to the receiver, (on a band ranging from 8000 to 20,000 kc.), then the oscillator is either working at 8470 kc. ( $8000 + 470$ ), or at 7530 ( $8000 - 470$ ); the problem is to determine whether the higher or lower oscillator frequency is correct, in order to align properly the high-frequency end of the band where two oscillator settings are obtained.

If the oscillator is working at 7530 kc., then it should be possible to drive a signal having a frequency of  $7530 - 470$ , or 7060 kc. through the receiver; and if the oscillator in the receiver is working at 8470 kc., then it should be possible to drive a signal having a frequency of  $8470 + 470$ , or 8940 kc. through the receiver. By varying the signal generator frequency



through each of these frequencies in turn, it is possible to determine the signal image frequency, and hence to determine whether the oscillator should be aligned above or below the signal frequency. By way of review, it can be noted that if the signal comes through below the dial frequency, then the oscillator is working below the signal frequency on the particular band being aligned, and consequently the maximum capacity setting of the oscillator trimmer at 20 mc. is the correct one. On the other hand, if the signal comes through above the receiver dial frequency, as is more common, then the minimum capacity setting of the oscillator trimmer should be taken at the high-frequency end of the band, (in this case, 20 mc.) To check for both of these image frequencies, it is generally necessary to raise the output of the signal generator, because the R.F. circuits are detuned from the incoming signal.

On the highest frequency band, it will often happen that two settings of the oscillator trimmer are possible at both ends of the band. If no information is available in the form of manufacturer's notes, then the receiver should first be aligned on the assumption that the oscillator frequency is above the signal frequency, and the minimum capacity settings of the oscillator trimmers should be used. If the dial calibration and sensitivity of the receiver are good over the entire range, and more especially at the middle of the range, then the choice is the correct one. On the other hand, if the dial calibration and sensitivity near the middle of the range are poor, the band should be realigned using the oscillator frequency below the signal frequency. Whichever of these assumptions gives the better receiver performance is the correct choice.

It should be mentioned that if a receiver is so designed that the oscillator works below the signal frequency on one band, this is no indication that this same relationship is maintained on all bands. On the contrary, receivers almost invariably work with the oscillator frequency above the signal frequency on the broadcast bands, but sometimes shift to below the signal frequency on the higher frequency bands, and more especially on the highest frequency band. There can be no general rule, and where the alignment data is not available, the above procedure will have to be followed to determine the correct oscillator frequency.

9. DOUBLE TRACE ALIGNMENT WITH AN OSCILLOSCOPE. In the first part of this lesson, we have discussed the general principles of alignment, using the simplest form of instruments, not because they are necessarily the best, but because of the simplicity of the explanation. For extremely accurate alignment work, the cathode ray oscilloscope is essential. A previous lesson described the operation of this instrument, as well as the principles of the frequency-modulated oscillator. In the following paragraphs, we will explain the application of these instruments to the alignment of superheterodyne receivers.

The order in which the circuits are aligned and the actual mechanics of alignment are the same whether an oscilloscope or an output meter is employed. Therefore, the following section will be devoted to the individual problems associated with the oscilloscope as used for circuit alignment.

In this discussion, it is assumed that a frequency-modulated signal generator is connected to the set in the same manner that the amplitude-modulated generator was connected when using the output meter. Also, the vertical plates of the oscilloscope are connected to the second detector in a manner to be explained in a following section.

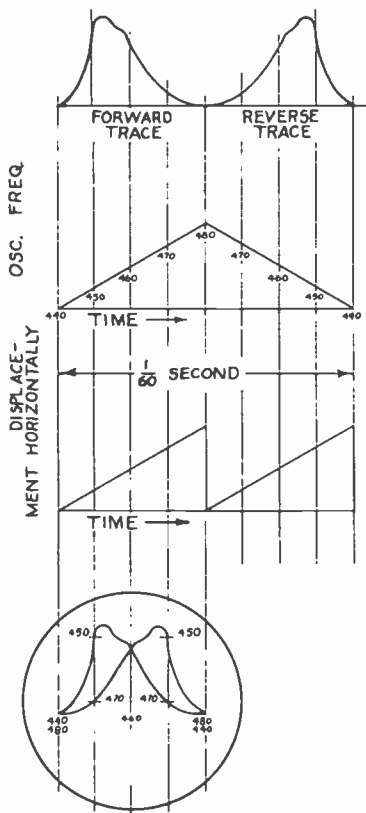

Fig.7 Illustrating the oscilloscope pattern produced when the I.F. amplifier is slightly out of tune.

There are two possible systems which can be used for visual alignment of tuned circuits; namely, the double trace system and the single trace system. Circumstances usually control which method is used, but as the double trace system is the most common, we will discuss it first.

Let us assume that we have an I.F. amplifier under test that is slightly out of tune. The double trace figure as seen on the

cathode ray screen is shown in Fig. 7. We shall also assume that the total frequency change in the sweep oscillator is 40 kc. and the rate of frequency modulation is 60 cycles per second. The resonant frequency of this amplifier is 460 kc., but as the amplifier is not in line, the peak of the curves do not fall at that point.

In  $1/120$ th of a second, the R.F. oscillator frequency progresses from 440 to 480 kc., tracing the response curve on the screen from left to right and controlled horizontally by the timing axis oscillator. This is called the "forward trace". At the end of  $1/120$  second, the oscillator frequency starts decreasing, and during the next  $1/120$  second, changes from 480 to 440 kc. At the reversal point (peak of the sawtooth voltage), the timing oscillator voltage which has caused the horizontal deflection to reach its maximum width on the screen, now drops to zero and returns the beam to the left side. It then builds up again, tracing the reverse resonance curve (480 to 440 kc.) during the second half of the sweep cycle. This is called the "reverse trace". Two partially superimposed curves are thus obtained on the screen, one being the reverse of the other with respect to frequency except at the point corresponding to the alignment frequency (460 kc.). In this figure, the circuits are purposely misaligned so that both traces (forward and reverse) will be distinguishable.

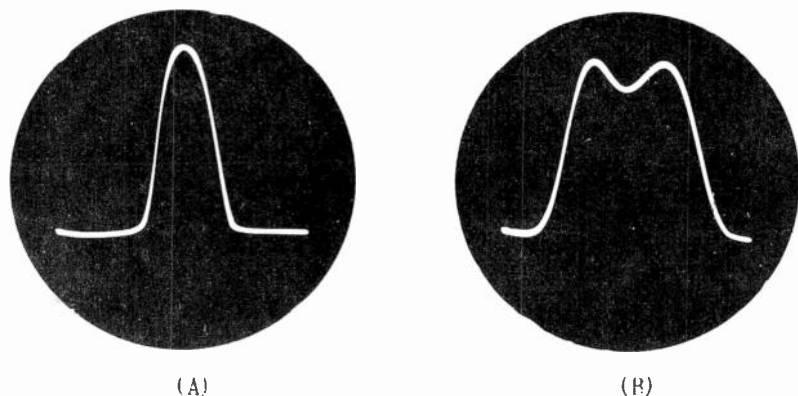

Fig. 8 (A) Screen pattern obtained when amplifier is properly tuned and adjusted for maximum selectivity. (B) Screen pattern when adjusted for maximum fidelity. The single pattern is symmetrical, which indicates proper alignment.

To align the circuit correctly, the tuning condensers on the I.F. transformers should be adjusted while watching the pattern on the screen. As the circuits are adjusted to bring the amplifier into alignment at 460 kc., the two separate patterns shown in Fig. 7 will come together and the peak of each will coincide at exactly 460 kc. It is quite probable that while the peaks are coming toward each other, the hump on the high-frequency side of

each trace will disappear. This will give a pattern on the screen consisting of both traces exactly superimposed on each other with both sides perfectly symmetrical as shown at A in Fig. 8. It will then be noticed that the sides of this response curve are not perfectly vertical, nor is the top flat over a wide range. If the circuits are adjusted for less selectivity and more fidelity, a double-peak symmetrical curve such as B in Fig. 8 will result. Curves of this type are typical of those obtained when a multi-stage I.F. amplifier is properly aligned.

When the double-image method of circuit alignment is used, the procedure is always to adjust the resonant circuits so as to make the separate traces coincide as closely as possible. If the circuits are thrown out of proper adjustment, the two traces will move apart. In a number of instances, it will be impossible to make circuit adjustments such that the two curves will exactly coincide over the entire pattern. It may be that the peaks can be made to coincide, but the sides of the curves will not come together and overlap properly. Also, it is likely that the two curves may coincide exactly, except at the bottom, where two traces will appear instead of one. In each of those cases where the two curves cannot be made to fall exactly upon each other, it is likely that some form of distortion, generally regeneration, exists in the amplifier. There are a number of other reasons why the perfect alignment curve cannot be obtained.

10. INTERPRETING SCREEN PATTERNS. In discussing the image obtained on the screen of the cathode ray tube, the two words "symmetrical" and "non-symmetrical" will be used quite frequently. A symmetrical resonance curve can be defined as one which shows the same amplitude response for frequencies which are higher or lower than the resonant frequency by the same amount. A symmetrical resonance curve can also be defined as one which could be cut through the middle along its vertical axis, then folded over and the two sides would coincide exactly. A non-symmetrical

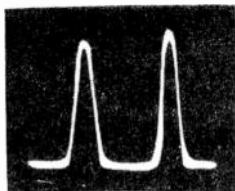
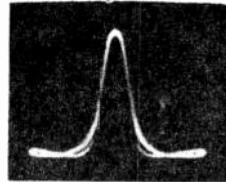

Fig. 9 Symmetrical resonance curves obtained when the sweep frequency and rate of frequency modulation are synchronized. Due to non-linear sweep voltage, the base of the right curve is narrower than the left curve.

resonance curve is one which does not possess these characteristics. It is possible for a resonance curve to have many different shapes, yet be perfectly symmetrical. Quite a number of these will be encountered throughout the discussion. A and B in Fig. 8 are examples of symmetrical resonance curves, but the curves shown in Fig. 7 are non-symmetrical because the response to frequencies above and below the resonant frequency of 460 kc. is not the same.

If the linearity of the sweep voltage from the sawtooth oscillator is not perfect, distortion of the screen pattern will result. This distortion generally appears as shown in Fig. 9. Note that the right hand curve is narrower at the base than the one at the left. This is due to the variation of the sawtooth sweep voltage from true linearity or straight line increase. When the sweep frequency is made double the rate of frequency modulation, distortion due to a non-linear sweep voltage would appear as shown in Fig. 10. In Fig. 10, it is assumed that the two images

Fig. 10 Screen pattern likely to appear when non-linear sweep voltage is used for double trace alignment.



are made to coincide by properly aligning the two circuits, but it will be impossible to make the bases correspond because of the distorted sweep voltage. This, of course, does not denote that the imperfect pattern is obtained because of defects in the amplifier under test unless there is regeneration in the amplifier. Regeneration is likely to cause a similar screen pattern to appear. By inspecting the sawtooth voltage wave from commercial oscilloscopes, it has been found that nearly all of them possess distortion to a certain extent. The presence of slight distortion does not prevent accurate circuit alignment, but it is necessary for the operator to be capable of interpreting the pattern.

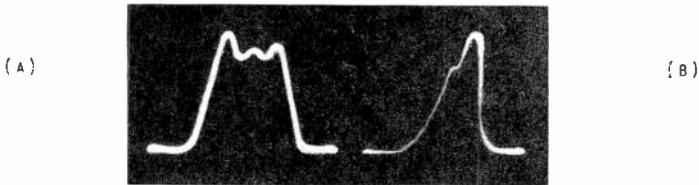

Fig. 11 (A) Non-symmetrical double peak curve obtained, due to regeneration. (B) Non-symmetrical single peak curve obtained, due to regeneration.

Regeneration in an R.F. or I.F. amplifier, regardless of how slight it may be, is nearly always apparent on the response curve. Presence of regeneration creates very peculiar conditions depending on the direction of the frequency sweep. This means that the circuit under test will act in one manner as the frequency from the test oscillator is being increased from minimum to maximum,

but acts in a different manner when the frequency from the test oscillator is being decreased from maximum to minimum. Assuming that the linear sweep is set to twice the rate of frequency modulation, the two curves traced on the screen will not coincide under these conditions. It is also unlikely that the two curves will be symmetrical; therefore, it will be impossible to obtain a single superimposed pattern when the resonant circuits are properly adjusted.

When regeneration is present, the curves will probably differ in amplitude at the related frequency peaks and in overall amplitude. Examples of the pattern which might be obtained due to the presence of regeneration are shown in Fig. 11. Both of these curves are non-symmetrical with respect to the mean or resonant frequency and represent very poor adjustment of the amplifier. By all means, the primary requisite for a good alignment curve is that it be perfectly symmetrical. Non-symmetrical curves always represent undesirable distortion of some form in the amplifier, (assuming a perfectly linear sweep) and hence, should not be tolerated. Regeneration and incorrect adjustment of the coupling between related tuned circuits are nearly always responsible for non-symmetrical curves.

A pattern such as is shown in Fig. 12 might at first be interpreted as non-symmetrical and representative of improper adjustment. This is not true, because close inspection will reveal that Fig. 12 is exactly the same on either side of the resonant frequency, even though the two humps or peaks are present. It is true that the maximum response from the amplifier is not obtained at the resonant frequency, but rather about 3 kc. on either side. If an I.F. resonance curve such as this is

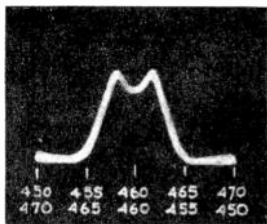

Fig. 12 Symmetrical double peak resonance curve of broadly tuned amplifier.

obtained, it represents satisfactory adjustment, because when the R.F. portion of the receiver is aligned, the increased gain obtained at the resonant frequency will compensate for the dip in the I.F. response curve, thus giving an over-all characteristic which is very satisfactory. From the standpoint of high-fidelity reproduction, a curve such as Fig. 12 is much more desirable than one such as the one shown in Fig. 8A. Fig. 8A represents the maximum response at the resonant frequency, but due to the sharp decline on either side, it is quite likely that the sidebands accompanying the I.F. signal will be badly depressed. In Fig.

12, the response from 455 to 465 kc. is fairly even; hence, all those sidebands up to 5000 cycles will be amplified practically the same, and the fidelity of the receiver will be much improved.

A possible source of pattern distortion caused by deficiencies of the test oscillator will be discussed by reference to Fig. 13. The frequency output of the test oscillator is varying from 440 to 480 kc., and the lines shown at A, B, and C represent three output voltages over this frequency band. At A, the output voltage is shown to be exactly the same value throughout the entire range from 440 to 480 kc. This is an ideal condition, and if distortion of the pattern obtained on the screen is to be prevented, a voltage output of this nature should exist. It is quite possible, however, that the output voltage will be different at one frequency than at another as the oscillator sweeps over the required band. One condition which might exist is shown at B in Fig. 13. Here the output voltage at 480 kc. is less than the output voltage at 440 kc. Since the signal strength as fed to the input of the amplifier is low at this frequency, a pattern on the screen which is truly representative of the amplifier response cannot be expected. Even if the response of the amplifier is exactly the same at 480 kc. as at 460 kc., the pattern on the screen will show a decided dip. If the service engineer were not familiar with the fact that such a dip on the pattern may be caused by a change in the voltage output of the test oscillator, he might interpret it to mean that improper adjustment exists in the amplifier under test.

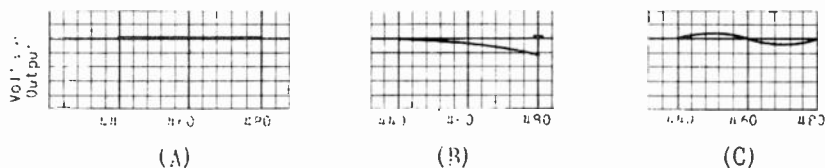
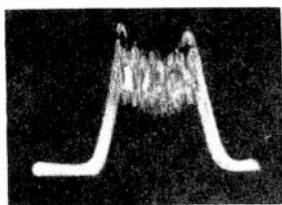

Fig. 13 (A) Voltage output of the oscillator remains constant from 440 to 480 kc. (B) Voltage output of the oscillator decreases as frequency increases from 440 to 480 kc. (undesirable). (C) Voltage output of the oscillator varies erratically over frequency range (undesirable).

Fig. 13C indicates that the output voltage of the test oscillator varies quite erratically over the frequency band from 440 to 480 kc. This variation may be resulting from the "Amplitude Modulation" control switch on the test oscillator being turned to the "On" position during the alignment procedure. This, of course, is undesirable because a perfect indication of the amplifier response will not be indicated by the pattern on the screen. The amplitude modulation control switch on the test oscillator should always be turned to the "Off" position, while using the visual method of circuit alignment. Most manufacturers design the switching circuit in the test oscillator so that when the frequency-modulation switch or sweep motor is turned on, the amplitude control switch is turned off at the same time. Ampli-

tude modulation of the frequency-modulated signal generally results in patterns on the screen such as shown at A and B in Fig. 14.

If an unstable pattern is obtained with broad lines and many spurious variations throughout its length, it is probably caused by the presence of another carrier voltage that is beating against the frequency modulated signal. If a condition of this kind is encountered, the service engineer should change the position of the tuning dial, disconnect the grid clip from the first detector, shield the lead from the frequency modulated oscillator, shield the leads to the vertical plates of the oscilloscope, or in general, take all precautions against the possibility of a stray carrier signal reaching the amplifier under test.



(A)

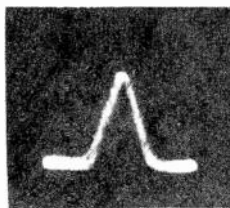

(B)

Fig. 14 Screen patterns likely to result when frequency modulated signal is amplitude modulated with 400 cycles.

Sometimes a ghost pattern may appear faintly behind the true pattern on the screen during the alignment procedure. This is generally due to a strong harmonic of the frequency modulated R.F. signal finding its way into the I.F. amplifier by feeding through the R.F. amplifier. To remedy this condition, the receiver may be detuned so that it does not respond to the harmonic, or the variable condenser plates of the oscillator section may be shorted.

In an attempt to secure a pattern on the screen, the service engineer may sometimes turn the vertical amplifier gain control on the oscilloscope down and the output signal from the test oscillator up. This is apt to result in overloading the I.F. amplifying tubes and the pattern obtained on the screen is usually quite distorted. Overloading is generally apparent on the image by making it abnormally bright at the peak with the sides faintly visible. The base of the curve does not ordinarily show a change in resonance except when the tubes are overloaded to the extent that grid current begins to flow. A typical curve resulting from a badly overloaded amplifier is shown in Fig. 15. The remedy for this condition is to decrease the oscillator signal voltage and advance the vertical amplifier gain control on the oscilloscope. With these adjustments, a pattern of the same dimensions may be obtained without the undesirable overloading.



In the alignment of closely coupled I.F. circuits, it is quite possible that the resonance curve can be made to coincide along the sides, but the peaks are not properly equalized. This condition is shown in Fig. 16. To align closely coupled tuned

Fig. 15 Image obtained on screen when amplifier is overloaded.

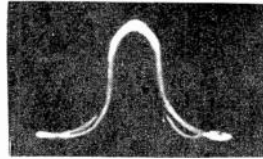

circuits correctly, it is necessary to equalize the peaks by adjusting the trimmer condensers until they are of the same amplitude. If there is regeneration in the circuit, it will be nearly impossible to obtain the desirable peak equalization. In all double-peak curves, such as Fig. 16, the resonant frequency is indicated on the pattern at the point where the two curves cross each other.

Fig. 16 Pattern resulting from misaligned, closely coupled circuits.

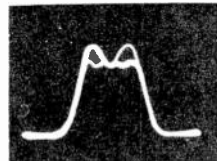

11. SINGLE-TRACE CIRCUIT ALIGNMENT. The double-trace method of circuit alignment is advantageous in that the "folding back" of the high and low-frequency sides makes symmetrical adjustments easy and very accurate. Also, the probability of frequency error in adjustment is reduced. For a given frequency error, the separation between the two curves of the double image is twice the displacement of the one curve when using the single-trace or conventional method. The small error is much more obvious with two images on the screen. The double-image method is generally used when testing a complete receiver or complete I.F. amplifier.

When using the single-trace method of alignment, it is possible to determine very accurately the correct adjustment in a single stage and with a calibrated chart in front of the screen, it is possible to obtain a visual indication of the true selectivity of a single stage or entire amplifier. The selectivity is indicated by the intersections of the pattern with the vertical lines on the screen chart. Ordinarily, the single trace pattern spreads out more in the vicinity of resonance than the double-trace pattern. This allows very accurate determinations of resonance to be made.

One method of securing a single image trace for visual circuit alignment is shown in Fig. 17. The curve at A represents the output of the frequency-modulated signal generator. The rate of frequency modulation is assumed to be 60 cycles per second, and the range over which the frequency varies is shown to be the same as in previous examples; that is, 440 to 480 kc., then from 480 to 440 kc. The curve at B shows the nature of the sweep voltage for this method of single trace alignment. During the first 1/120 of a second, the spot is swept across the screen from left to right, then returned rapidly to the left side. During this movement of the spot, the frequency has changed and a vertical displacement of the beam has occurred which corresponds to the response of the amplifier under test as shown at C in Fig. 17. The resonant frequency is assumed to be 460 kc. and it can be seen that the peak response occurs at this frequency, indicating exact alignment of the tuned circuit.

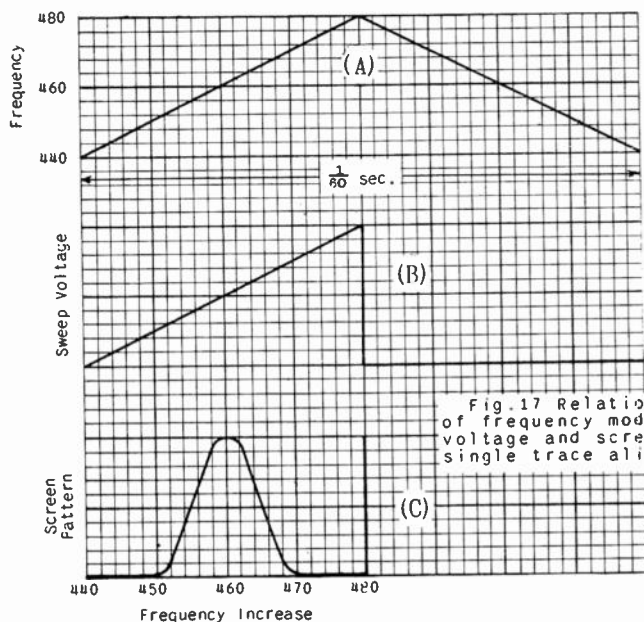

Fig. 17 Relation between rate of frequency modulation, sweep voltage and screen pattern for single trace alignment.

During the second 1/120 of a second, while the frequency from the modulated oscillator is decreasing from 480 to 440 kc., the sweep voltage is zero, which means that the spot is not moved across the screen.

The essential difference between the double-trace and the single-trace methods is that in the single trace, the sweep circuit supplies horizontal displacement during only one-half of the frequency variation. Frequency modulation of the input signal voltage is occurring during the entire 1/60 second; however, the

spot is moved across the screen only during the first 1/120 of a second. During the second 1/120 second when no horizontal displacement of the beam occurs, there is still vertical displacement due to the response of the amplifier as the frequency passes through resonance when decreasing from 480 to 440 kc. With vertical displacement only, a straight line appears on the right side of the screen. Most of the modern oscillator-oscilloscope combinations for visual circuit alignment are designed so as to eliminate the vertical line on the right side of the screen.

This is usually accomplished by having the spot on the oscilloscope return from right to left at the same speed as it moves from left to right. By so doing, the curve on the screen actually traces back on itself giving only a single image.

Regardless of the circuit misalignment in the amplifier under test, only a single pattern will be obtained on the screen. The image is not being folded back upon itself as in the double-trace method of alignment because the beam travels at the same speed in both directions. In the double-trace method, the beam was moved from left to right as the frequency increased, then rapidly returned to the left and again moved from left to right as the frequency decreased. This is not true in the single-trace method. During the frequency increase, resonance in the tuned circuit under test is approached on the same side as during the frequency decrease.

Fig. 18 (A) Resonance curve obtained with single trace alignment when tuned to 470 kc. (B) Resonance curve obtained with single trace alignment when tuned to 456 kc.

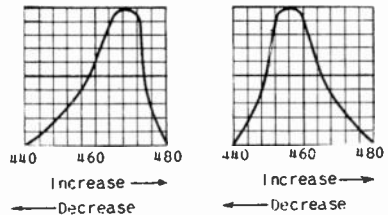

(A)

(B)

If the tuned circuits under test were aligned to a frequency of 470 kc. instead of 460 kc., the resonance curve obtained using the single-trace method would appear as shown in Fig. 18A. The peak of the resonance is at 470 kc., while the response at 460 kc. is comparatively low. The response curve is not symmetrical, which also represents misalignment. If this image is obtained on the screen, it is necessary to retune the adjusting condensers in the amplifier until the peak is obtained at exactly 460 kc. and the curve is symmetrical on both sides. If a symmetrical curve cannot be obtained even when the peak is at 460 kc., regeneration in the amplifier is probably the cause.

Fig. 18B shows the appearance of a single-trace response curve when the amplifier is aligned to a frequency of approximately 456 kc. instead of 460 kc. Again, the curve is not perfectly symmetrical, so the tuning condensers in the amplifier must be adjusted until a symmetrical curve is obtained with the peak at

460 kc. This is assuming that it is desired to align the set at 460 kc. On most oscilloscopes, a frequency-calibrated celluloid chart can be inserted over the screen of the tube, thus making it possible to observe the exact selectivity or response curve of the amplifier under test. With this calibration chart, the exact location of the resonant frequency can easily be observed and the shape of the curve clearly indicates the response of the amplifier to frequencies off resonance on either side. If a high-fidelity adjustment is desired, the tuned circuits may be "staggered" slightly, thus broadening out the curve at some sacrifice to sensitivity. During these adjustments, the object is to secure a response curve which is nearly flat on top and has broad, straight sides.

All the possible sources of distortion mentioned in connection with the double-image method of alignment are also true with regard to the single-image method. Particularly is this true of regeneration, because regeneration in the amplifier under test will always result in a non-symmetrical curve on the screen. If the regeneration is sufficient, the damped oscillations accompanying this condition can be observed on one side or the other of the single-image response curve.

The pattern obtained on the screen for an I.F. amplifier adjusted for high-fidelity conditions is shown in Fig. 19A. The overall response curve for this receiver, obtained when the frequency-modulated signal is fed into the antenna is shown in Fig. 19B. Notice that the response curve of the R.F. portion of the receiver superimposed on that of the I.F. amplifier raises the amplification at the mean frequency, thus producing a nearly flat top for the curve.

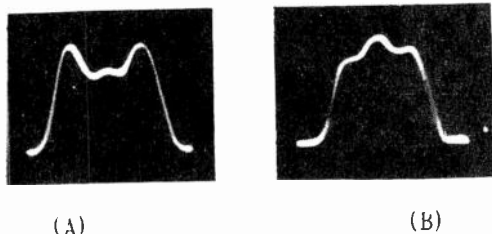

Fig. 19 (A) Typical screen pattern for a high fidelity I.F. amplifier. (B) Same pattern as A, with the R.F. section of the receiver included.

## 12. CONNECTING THE OSCILLOSCOPE TO THE DETECTOR CIRCUIT.

The vertical deflection of the cathode ray beam depends entirely upon the strength of the rectified voltage in the detector circuit, which in turn is determined by the response of the amplifier under test. The vertical plates of the oscilloscope must, therefore, be connected at some convenient place in the detector circuit so as to secure the vertical deflection. If the voice coil of the receiver is allowed to remain connected during the frequency modulated alignment procedure and the audio volume control

is turned up, the pulsations in the output of the detector may be heard from the speaker. Even though these pulsations pass through the audio frequency amplifier, an attempt should never be made to connect the vertical plates of the oscilloscope any place in the A.F. circuit except the detector output. The reason for this is that the average A.F. amplifier causes sufficient phase distortion so that the pattern obtained on the screen will be badly distorted.

To develop the image on the screen, it is necessary that deflection of the cathode ray beam be produced in two directions, horizontal and vertical. The horizontal is always secured from the sweep voltage employed and the vertical deflection results from the audio frequency voltage obtained in the detector circuit. In order that this vertical deflection voltage be available for application to the vertical plates of the cathode ray tube, it is necessary to convert the I.F. signal voltage from the frequency-modulated oscillator into an audio voltage variation. This can be done by feeding the signal voltage developed across whatever circuit is being checked into a detector tube and rectifying the I.F. voltage. Throughout our discussion, for the purpose of explanation, we have assumed that the frequency modulation was from 440 to 480 kc.; hence, at each instantaneous frequency within this band, a rectified voltage must be developed across the detector load or output circuit. The waveform of this rectified voltage during a complete cycle of the frequency modulation, will be in accordance with the resonance characteristics of the amplifier under test, and hence, may be used for vertical deflection.

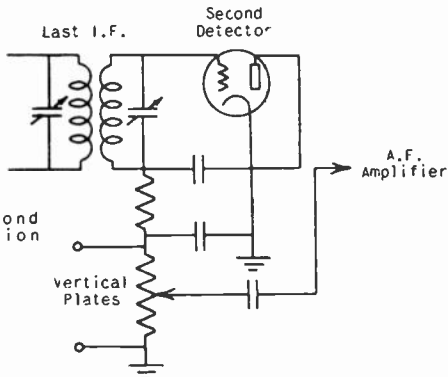

Fig. 20 Diagram of diode second detector to show proper connection of vertical plates.

First of all, the leads used to connect from the detector circuit to the vertical plates of the oscilloscope should be of the low-capacity shielded type. This prevents the induction of stray voltages which would cause considerable distortion of the screen pattern.

The actual connections to the detector circuit depend to a large extent upon the type of detector being employed. First, we

shall assume that the detector is of the diode type. In Fig. 20 the vertical plates of the oscilloscope are connected directly across the audio volume control. The volume control can be decreased to minimum to prevent the buzzing from the speaker during the alignment procedure; this does not interfere in any way

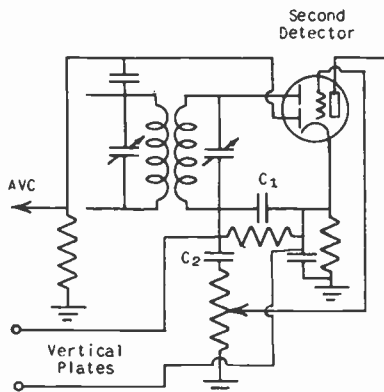

Fig. 21 Vertical plate should be connected to the diode load resistance instead of directly to the volume control when the volume control is not the diode load.

with the vertical deflection on the oscilloscope. Some volume controls are tapped and have a network for bass compensation. Such networks should always be disconnected from the volume control because they tend to introduce phase distortion, thus making it impossible to secure the proper pattern on the screen.

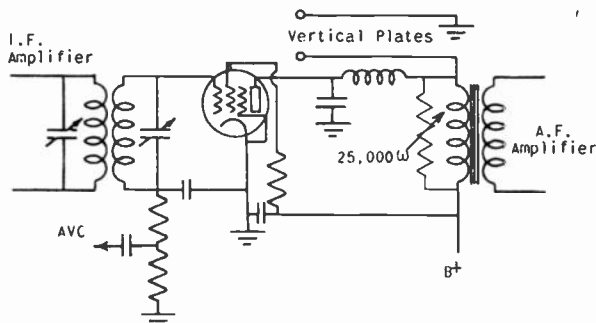

Fig. 22 Pentode bias detector circuit with vertical plate connected to the top of the primary winding. The 25,000 ohm rheostat must be used to prevent phase distortion on the pattern.

Fig. 21 shows a duo-diode-triode being used as a second detector. In this circuit, the volume control is not serving as the load for the diode circuit, but rather is connected in such a manner as to secure the A.F. variations through the coupling condenser C2. Since this coupling condenser is not generally of sufficient size to prevent excessive phase distortion, it is advisable to connect the vertical plates of the oscilloscope to the diode load resistance instead of across the volume control.

If the coupling condenser C2 is increased to at least 1 or 2 mfd., the phase distortion will be negligible and it is permissible to connect the vertical plates of the oscilloscope across the volume control as in Fig. 20. With a little experimentation in the detector circuit, a place of connection may generally be located where excessive phase distortion is not obtained, so it is unnecessary to insert high-capacity condensers merely for the purpose of preventing phase distortion across the audio volume control.

Fig. 22 shows a pentode tube connected as grid bias detector, with the primary of an audio transformer serving as the plate load. An inductive plate load will always cause phase distortion, so compensation must be provided in circuits of this kind before the correct resonance curve can be obtained on the screen.

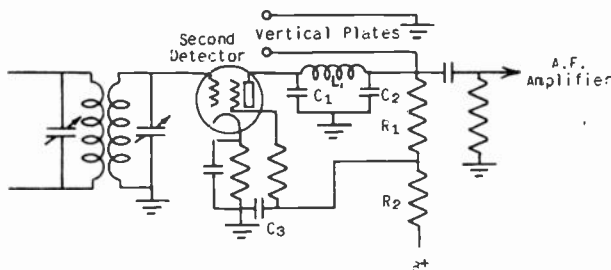

Fig. 23 Screen grid bias detector circuit. Vertical plate must be connected on the load side of the R.F. filter.

The vertical plates of the oscilloscope are to be connected as indicated in Fig. 22. The ungrounded vertical plate should never be connected directly to the plate of the second detector, because the R.F. present at the plate causes a fuzzy and somewhat distorted pattern. By connecting the ungrounded vertical plate to the top of the transformer primary, the R.F. filter in the detector plate circuit will remove the R.F. variations, thus eliminating this source of pattern distortion. To prevent the phase distortion caused by the inductive load, a 25,000 ohm rheostat may be shunted directly across the primary. This is shown in Fig. 22. By varying the movable arm on the rheostat and watching the pattern on the tube, a value will be secured where the phase distortion is at zero or minimum. Upon changing the size of the 25,000 ohm rheostat, it may be that the pattern will decrease in amplitude. This may be compensated for by increasing the gain control on the vertical amplifier.

When pure resistance is used as the plate load on the second detector (grid bias detection), it is very unlikely that any phase distortion will be produced in the plate circuit if the by-pass condensers are of sufficient capacity. Fig. 23 shows a screen grid tube being used as a grid bias second detector and the correct position for the vertical plate connection is indicated. Since the resistance R1 is serving as the plate load, the

phase distortion will probably be negligible. In case the R.F. filter inductance L1 is appreciable in size, a slight phase distortion may result from that source.

13. RECEIVER ALIGNMENT. To supplement the foregoing information on the procedure for aligning a receiver, using the cathode ray tube and frequency modulated oscillator, we shall follow through the process of adjusting a modern receiver by this method.

The schematic circuit diagram of a modern receiver is shown in Fig. 24. This is a 3-band superheterodyne, AC receiver, using metal tubes throughout. Several features, characteristic of modern receivers are incorporated in its design.

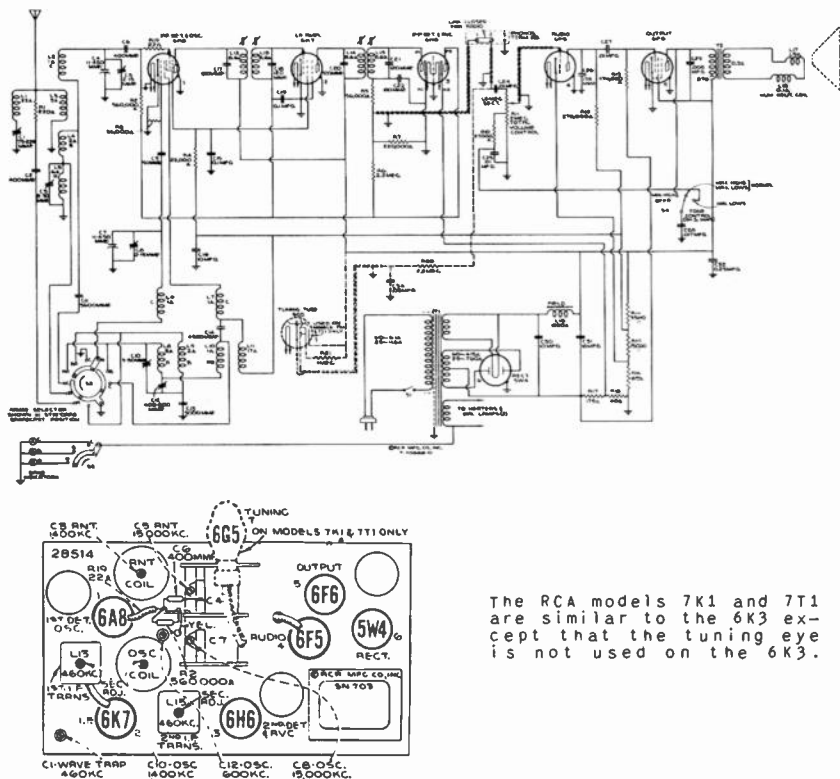

The RCA models 7K1 and 7T1 are similar to the 6K3 except that the tuning eye is not used on the 6K3.

Fig. 24 Schematic wiring diagram and block diagram showing tube and trimmer locations of RCA 6K3 receiver.

The vertical plates of the cathode ray oscilloscope should be connected directly across the diode load resistance R7. This connection can be made conveniently by fastening the ground lead from the oscilloscope to the receiver chassis and the ungrounded lead from the oscilloscope to terminal #1 on the phonograph terminal board. A shielded cable should be used for this purpose.



Since the vertical plates are directly across the diode load resistance, and there is no inductance or capacity in this part of the circuit, the phase distortion will be negligible.

It is never advisable to start aligning any part of a receiver without first making certain that the tuned circuits are fairly close to the resonant frequency. If the circuits are badly detuned, when the frequency modulated signal is fed to the input, it will be very difficult or impossible to locate the resonance curve on the screen of the cathode ray tube by adjusting the linear sweep voltage. For this reason, the service engineer should first "amplitude modulate" the test signal and verify the approximate circuit alignment of the amplifier under test. This is done by adjusting the signal generator to the frequency of the I.F. amplifier, connecting it to the input of the amplifier and turning the "amplitude modulation" switch on. With the vertical plates of the oscilloscope connected in the detector circuit and the vertical amplifier gain control advanced full on, adjust the R.F. attenuator on the oscillator until an image about one inch high is secured on the screen. Then turn the sweep control switch on the oscilloscope to "linear", adjust the linear sweep voltage to 100 cycles and (assuming 400-cycle amplitude modulation) four cycles will appear on the screen. These cycles may be held stationary by adjusting the "control voltage" potentiometer on the oscilloscope.

#### ALIGNMENT PROCEDURE

Order of Alignment	Test Oscillator			Receiver Dial Setting	Circuit to Adjust	Adjustment Symbols	Adjust to Obtain
	Connection to Receiver	Dummy Antenna	Frequency Setting				
1	6K7 i-f Grid Cap	.001 Mfd.	460 kc	No signal 660-760 kc	2nd i-f Trans.	L14 and L15	Max. (peak)
2	6A8 Det. Grid Cap	.001 Mfd.	460 kc	No signal 550-750 kc	1st i-f Trans.	L19 and L13	Max. (peak)
3	Ant. Post	200 Mmfd.	460 kc	No signal 550-750 kc	Wave Trap	C1	Minimum Output
4	Ant. Post	300 Ohms	15,000 kc	15,000 kc	"C" Osc.	C8	Max (peak)*
5	Ant. Post	300 Ohms	15,000 kc	Rock thru 15,000 kc	"C" Ant.	C6	Max. (peak)
6	Ant. Post	200 Mmfd.	600 kc	600 kc	L-F Osc.	C12	Max. (peak)
7	Ant. Post	200 Mmfd.	1,400 kc	1,400 kc	H-F Osc.	C10	Max. (peak)
8	Ant. Post	200 Mmfd.	1,400 kc	1,400 kc	"A" Ant.	C3	Max. (peak)
9	Ant. Post	200 Mmfd.	600 kc	Rock thru 900 kc	L-F Osc.	C12	Max. (peak)
10	Ant. Post	200 Mmfd.	1,400 kc	1,400 kc	H-F Osc.	C10	Max. (peak)
11	Ant. Post	200 Mmfd.	1,400 kc	1,400 kc	"A" Ant.	C3	Max. (peak)

\* Use maximum capacity peak if two peaks can be obtained.

Fig. 25 Outline of alignment procedure for RCA 6X3 receiver.

Each of the I.F. tuned circuits should now be adjusted to resonance. Resonance is indicated by maximum height of the four-cycle image on the screen. In the receiver shown in Fig. 24, the I.F. is 460 kc. To start the alignment on this receiver, the test oscillator should be adjusted to 460 kc. and "amplitude" modulated. Then, observing the vertical height of the image on the screen, align the I.F. circuits to resonance.

The order of alignment on any receiver is very important; this information is generally given in the manufacturer's service notes. Also, a "dummy antenna" must be used in most instances between the "high" test oscillator output and the point of connection to the receiver in order to obtain ideal alignment. The chart given in Fig. 25 outlines the exact procedure to follow for aligning the receiver. "No-signal 550, 750 kc." means that the receiver should be tuned to a point between 550 and 750 kc. where no signal or interference is received from station or local oscillator.

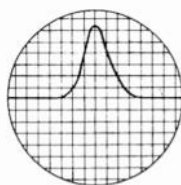

A

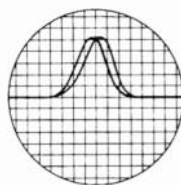

B

Fig. 26 (A) Correct curve showing proper I.F. alignment (double trace). (B) Incorrect curve similar to A, showing improper alignment of I.F. system caused by one or more circuits being slightly detuned.

Following the procedure outlined in the chart, the second I.F. transformer is aligned first, then the first I.F. transformer. The dummy antenna for these alignments is a .001 mfd. condenser in series with the antenna lead from the test oscillator. The wave trap is aligned next, with the test oscillator (460 kc.) connected to the antenna post of the receiver and a 200 mmfd. condenser as the dummy antenna. After these three circuits have been properly adjusted using amplitude modulation, reconnect the test oscillator to the 6A8 and set the controls for frequency modulation. Synchronize the linear sweep oscillator in the oscilloscope to 120 cycles for double-trace alignment (assuming rate of frequency modulation is 60 c.p.s.). The vertical plates of the oscilloscope remain connected across the diode load resistance the same as before. If a screen pattern as shown at A in Fig. 26 is obtained, all the I.F. circuits are properly aligned and there is no need for further adjustment. Should the pattern show two traces, however, as at B in Fig. 26, one or more of the I.F. trimmers are slightly mis-tuned.

After aligning with double trace, it is advisable to set the oscillator and oscilloscope controls for a single-trace pattern and inspect the exact selectivity curve of the I.F. amplifier. Should it be desired to decrease the selectivity, and thereby

increase the fidelity, the tuned circuits may be staggered by slightly detuning the trimmers on alternate sides of resonance. The increased fidelity resulting from "staggering" is secured at the sacrifice of sensitivity. A double-peak resonance curve will probably result, due to the staggered tuning.

When the I.F. adjustments have been completed, reset the test oscillator for "Amplitude Modulation", connect it through a 300 ohm dummy antenna to the antenna post, set the dial to 15,000 kc., turn the receiver band switch to band C and set the receiver dial to 15,000 kc. Now synchronize the linear sweep to 100 cycles and proceed to make the short-wave alignments as outlined under (4) and (5) on the chart in Fig. 25.

Next in the order of alignment is the low-frequency adjustment on the oscillator. Using amplitude modulation of the test signal and observing the four cycles on the cathode ray screen, set the test oscillator and receiver dial to 600 kc. (band A). Adjust the low-frequency oscillator trimmer C12 for maximum amplitude on the screen. The first detector and high-frequency oscillator adjustments are made next at 1400 kc. Then return to the low-frequency oscillator trimmer and "rock" the tuning dial through 600 kc. while adjusting for peak amplitude. This is done to compensate for local circuit interactions between the oscillator and first detector. The final amplitude adjustment is to return to 1400 kc. and check the alignment of the high-frequency oscillator trimmer and the first detector.

Upon completion of the "amplitude" adjustments, set the controls on the signal generator and oscilloscope for double-trace visual alignment. With the frequency-modulated signal fed into the antenna post of the receiver, adjust the receiver and test oscillator to the same frequency and the pattern will appear on the screen. As with the I.F. amplifier, if only a single trace appears, the circuits are aligned properly, but if the two curves are slightly displaced, a readjustment of one or more of the tuned circuits is necessary. Make these adjustments, then set the frequency-modulated test oscillator and oscilloscope for single-trace alignment and observe the overall selectivity curve of the receiver on the calibrated screen.

If all the above directions have been followed in the proper manner, the receiver should be properly aligned.

In the preceding paragraphs, we have not discussed the alignment of AFC circuits. These have purposely been omitted so that we can give you more definite information in the following paragraphs. The alignment of AFC circuits varies somewhat from the alignment of I.F. and R.F. circuits. To show the method clearly, let us explain the alignment of a typical AFC circuit, as illustrated in Fig. 27.

A cathode ray oscilloscope of the usual type may be used in conjunction with a frequency-modulated signal generator, supplying a 465 kc. signal. No audio frequency modulation should be used. Apply this signal to the grid of the first I.F. amplifier tube through a .05 mfd. condenser. Connect the vertical plates of the

oscilloscope from ground to the center point between the two diode load resistors. Set the tuning dial indicator at the low end of the broadcast band at some point where no signal is received, since an extraneous signal might interfere with the aligning process. The volume control should be in the off or nearly off position. Place the AFC switch in the "Off" position.

After aligning the I.F. circuits in the usual manner, further adjustment of the AFC secondary (hexagonal nut) trimmer is necessary in order to complete the I.F. alignment satisfactorily. This adjustment is as follows:

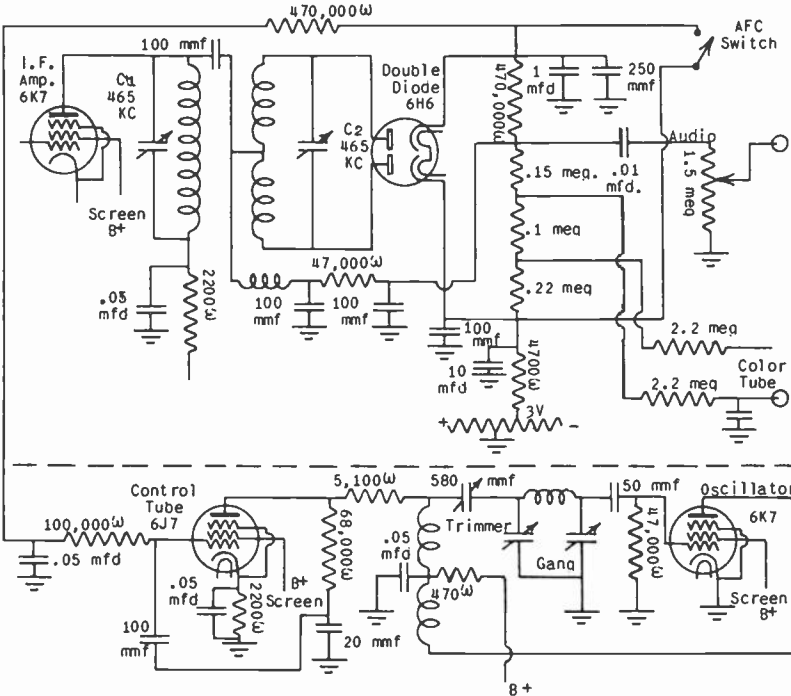

Fig. 27 A typical AFC circuit as used in a modern receiver.

Apply the same signal to the grid of the second I.F. amplifier tube. Disconnect the large condenser across the extreme ends of the diode load resistors, and connect the vertical plates of the oscilloscope between ground and the top end of the top diode load resistor (one side of the AFC switch). With the AFC switch in the "on" position, carefully adjust the AFC secondary trimmer until the two sides of the curve are approximately symmetrical and intersect exactly at the axis, as shown in Fig. 28. No adjustment of any other I.F. trimmer should be made at this time.

If a metal aligning tool is used, the curve will change when the tool is withdrawn. Therefore, it is advisable to use a fibre

tool for this aligning adjustment. At any rate, the final curve should be as shown, with the aligning tool removed.

Although the use of the cathode ray oscilloscope for aligning purposes is to be preferred, it is possible to make the AFC trimmer adjustments with reasonable accuracy using a 465 kc. signal generator and an accurate low-range output meter.

Fig. 28 Oscilloscope pattern obtained with correctly aligned AFC circuit.

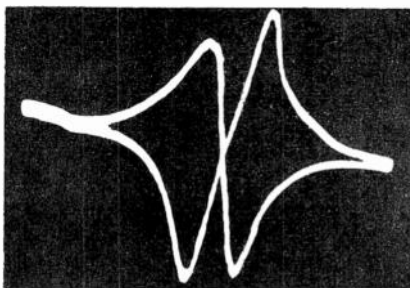

Place an amplitude modulated signal of 465 kc. on the grid of the last I.F. tube with the volume control set at maximum and the AFC switch turned off. Place a low-range AC voltmeter or other output indicator across the voice coil of the loudspeaker. Adjust the output of the signal generator so that an indication of not more than 2 or 3 volts is obtained on the output meter.

Adjust the primary trimmer for maximum output and the secondary for minimum output. This latter adjustment will be very broad. Apply the signal input to the grid of the first I.F. tube and adjust both primary and secondary trimmers for maximum output, reducing the input as necessary to obtain approximately the same output indication as before. Apply the signal input to the grid of the converter tube and adjust both primary and secondary trimmers for maximum output indication in the same manner as before.

It is now necessary to make a fine adjustment of the secondary trimmer on the last I.F. (AFC) transformer, which is as follows: Without changing the frequency of the signal generator, place the input lead near or touching the converter grid lead. This will provide a small signal input through the capacity between the leads. Increase the attenuator setting, if necessary, to make the output audible. If the signal generator is provided with a means of removing the modulation, this should be done. However, the adjustment may be carried out satisfactorily even with a modulated generator signal.

Now tune in any broadcast signal in the usual manner and tune the receiver carefully for zero beat between this carrier and the 465 kc. signal generator. It may be necessary to use a short antenna or remove it entirely if the station is a strong local. Throw the AFC on and adjust the last I.F. secondary (AFC) trimmer by ear for zero beat. This adjustment is very critical and must be made with great care. When the adjustment is properly made, there will be no appreciable change from zero beat as the AFC

switch is thrown off and on. This completes the alignment of the I.F. and AFC circuits in the receiver. The alignment of the oscillator and R.F. circuits may be carried out in the usual manner; however, the AFC switch must remain in the "Off" position.

The text of this lesson was compiled and edited by the following members of the staff:

G. L. Taylor  
President and Chief Engineer  
Midland Radio & Television Schools, Inc.

C. L. Foster  
Supt. of Instruction  
Midland Radio & Television Schools, Inc.

C. V. Curtis  
Chief Instructor  
Midland Radio & Television Schools, Inc.

R. E. Curtis  
Technical Drafting  
Midland Radio & Television Schools, Inc.

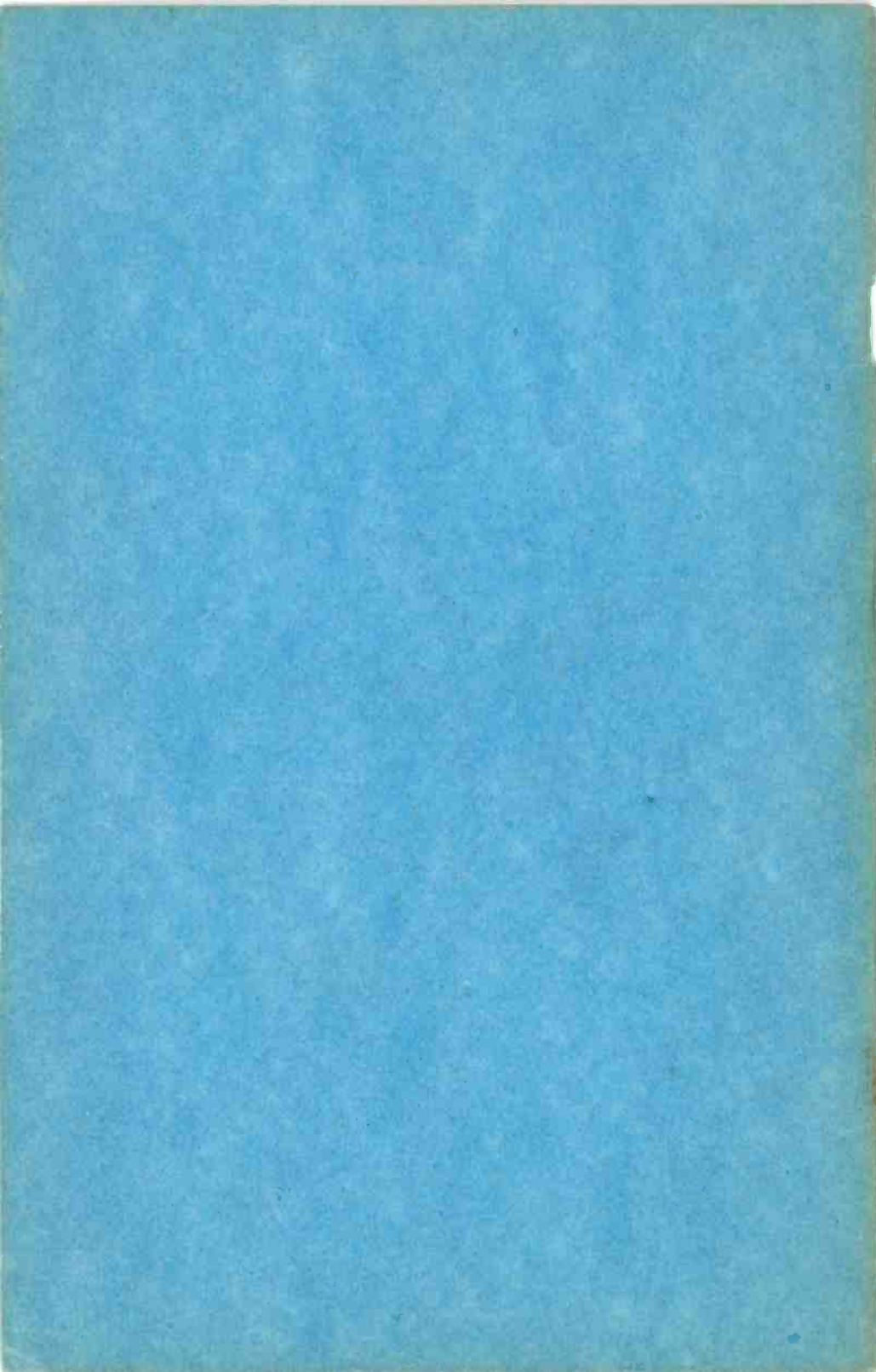





**MIDLAND RADIO  
AND TELEVISION  
SCHOOLS  
INC.**

**POWER & LIGHT BUILDING, KANSAS CITY, MISSOURI**

**UNIT  
NO.  
2**

**SIGNAL TRACING**

**LESSON  
NO.  
6**

# THE HIGH CLOUDS

.....HAVE THE SILVER LININGS

When the clouds come down, and fog hangs over the earth, aviators say, "The ceiling is low". They know that to attempt a flight under these conditions might well end in disaster. They cannot hope to rely upon their own limited senses with any degree of safety, and only the most foolhardy one among them dares take a chance on a deadly tailspin so close to the ground.

Every man, woman, and child in the world has a "mental ceiling". No one person can know everything. If he is given a problem, he may go only as far toward its solution as his education and his knowledge of the subject will allow. He can "take a chance" and attempt to guess his way along, but he will fall into a "mental tailspin".

Radio, like everything else, is like that, too. An engineer is rated according to the height of his mental "ceiling". If he knows his subject well, and he doesn't have to guess at all, his "ceiling" is high.

Every lesson that you complete raises your own ceiling. Every experiment that you conduct, every unit that you build, places your ability on a higher level. As your knowledge and experience build up, your efficiency grows.....and it is your efficiency that makes you valuable to your employer and to yourself! As YOU increase in value, your income gets bigger and bigger.

Remember, as you progress through each lesson, that each important fact.....every paragraph..... is raising your MENTAL CEILING higher and higher!

AND..... as your "ceiling" goes up, so does your value, to yourself and to your employer!

Copyright 1942  
By  
Midland Radio & Television  
Schools, Inc.

PRINTED IN U.S.A.



KANSAS CITY, MO.

# Lesson Six

## SIGNAL TRACING

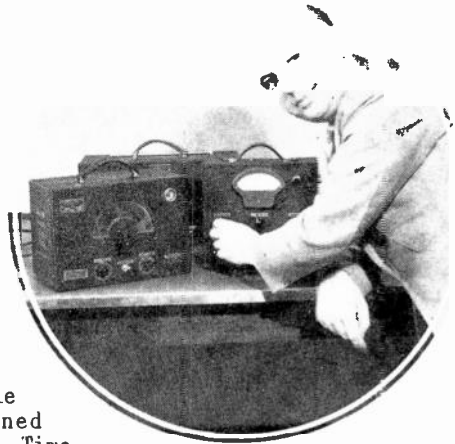

"The radio serviceman, like all other present-day technical men, should be well acquainted with the nature and operation of the instruments that have been developed to enable him to attain the streamlined efficiency expected of him. Time saved in spotting and correcting the source of trouble in a radio receiver may be a determining factor in the volume of business that he is able to handle.

"This lesson deals with one of the most dependable methods of servicing; that of feeding a signal into the receiver and tracing the signal through the entire receiver until the defective component or other discrepancy is located. You will also find listed and explained several instruments now on the market, especially adapted to this type of servicing."

1. THE BASIS OF SIGNAL TRACING. In previous lessons two different systems of receiver circuit tracing have been discussed. First, there was the voltage-current analysis of a receiver. This method assumes that any fault in the receiver will manifest itself in some deviation of the operating voltages or currents. That this assumption is not strictly true is evidenced by the fact that such a simple fault as an open coupling condenser will make the receiver inoperative, but will cause no change in the operating voltages.

The second system, which is based on the resistance measurement of the component parts of the receiver, is useful in conjunction with the voltage-current analysis for finding the defective component after the trouble has been localized. Even this system, however, has its limitations; it will not locate open condensers, nor is it rapid in its application. Of course, a condenser tester may be utilized to check the condensers and such an instrument should be a part of every serviceman's collection. It is the time element, however, which is of great importance. The serviceman's time is one of his principal commodities, and unless he can make use of that time profitably, his volume of business and his income suffer.

Now signal tracing enters the picture. It is a radically new and different method of receiver circuit testing. It is

rapid; it is accurate; and it requires no particular skill. The only way the average person can detect a fault in his receiver is by noting the signal from his loudspeaker. If the set is dead he has no signal; if it has a low output, the signal is weak; and if noise, distortion, or oscillation is present, he has an improper signal. Thus, whether the serviceman is called in to make repairs or not depends on the quality of the signal as noted by the owner.

Assuming, now, that something is wrong with the set and that the serviceman has been commissioned to repair it, the next step is to decide what method of circuit testing is to be used. The failure of the signal gave him the job. The owner is interested in having the signal restored to its original condition. Is it not logical for the serviceman to use a method of testing which traces the signal from the antenna to the speaker, determines where the signal disappears, or locates the point where noise, distortion, or oscillation is produced? After the fault has been localized, then the component parts associated with that stage or circuit may be tested individually for defects using the test instrument most suited for the purpose. Every receiver has a signal (or let us say should have a signal); therefore, signal tracing is universal in its application. Furthermore, it may be applied while the receiver is in operation without affecting the stability.

How do we detect the presence of a signal? Obviously there are several possibilities. We may make use of headphones, oscilloscope, or a vacuum tube voltmeter. If the set is normal, there will be a signal voltage present between each control grid and ground, and between each plate and ground. In addition there will be a signal present between the antenna and ground and across the voice coil of the speaker. Naturally, we must remember that the signal undergoes various changes in passing through the receiver. In the RF stages, the signal will be of radio frequency. In the IF stages it will be of an intermediate frequency, and in the audio stages it will be of audio frequency. In addition there will be an oscillator signal produced by the oscillator of the set. Since the signal does have such a variety of forms, the same method of its detection will not be suitable for all parts of the receiver. Naturally, the headphones will be of no value in detecting the presence of a signal in the RF and IF stages. The oscilloscope offers better possibilities, but there is need for an even more accurate method of detection. This method is the vacuum tube voltmeter.

A vacuum tube voltmeter is comparatively simple to operate; is rapid in its application; and can be designed to indicate the presence of very small voltages. For use in the RF, IF, and oscillator stages, the vacuum tube voltmeter should be tuned. This serves two useful purposes: first, tuning makes the instrument more sensitive; second, a calibrated frequency scale allows the frequency measurement of signals whose frequency is unknown. To have the greatest utility, the vacuum tube voltmeter should be calibrated; that is, it should not only detect the presence of a

signal but should indicate its relative magnitude. Let us make certain that we understand the meaning of this. When the probe of the vacuum tube voltmeter is connected to the grid of an RF stage, we should obtain some definite arbitrary reading. Now it is not necessary that we know exactly the volts or millivolts existing at this grid, but we should have some reading so that when the probe is connected to the plate of this same stage, we can determine the amount of gain of the stage and thus detect the presence of a fault. Checking the gains of the various amplifier stages is an important part of signal tracing, especially when the complaint is lowered sensitivity.

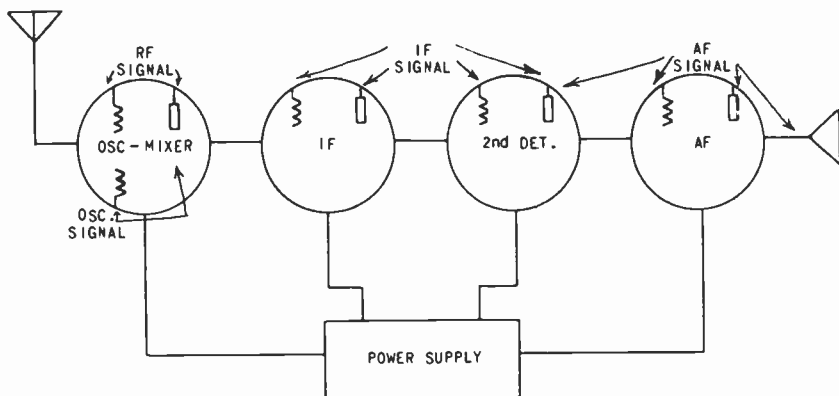

Fig.1 Functional diagram of a simple superheterodyne receiver.

The vacuum tube voltmeter which is used to check the AF stages naturally cannot be tuned; it should, however, give an indication of the relative magnitude of the signal present so that the gain per stage may be computed. Another section of this lesson will deal with the explanation of several commercial signal tracing instruments which include the necessary vacuum tube voltmeters for this method of checking.

A rather thorough knowledge of circuits and their functions is necessary so that the serviceman can interpret his findings. In fact, there can be no very definite procedure outlined for signal tracing, since each set has its individual problems. If the serviceman has the proper theoretical background, this is no deterrent; signal tracing can be applied to any radio receiver. Consider for example the functional diagrams illustrated in Figs. 1 and 2. The receiver of Fig. 1 is a simple four-tube superheterodyne, typical of many of the midget receivers in use today. Also shown on this diagram are some of the basic points where the signal in its various forms should be found. Now let us examine Fig. 2. Here there is illustrated a much more elaborate receiver. It has ten tubes, a push-pull stage, an AVC circuit,

and a separate local oscillator. Yet the only real difference between the two circuits so far as signal tracing is concerned is that the larger set has more basic points and may require more checks before the trouble is located.

The larger set shown in Fig. 2 also presents another problem. In addition to determining the quality and presence of the signal at each of the basic points, we must also check the presence and magnitude of the AVC control voltages. We must be able to differentiate between operating voltages and control voltages. Operating voltages include plate and bias voltages and are present

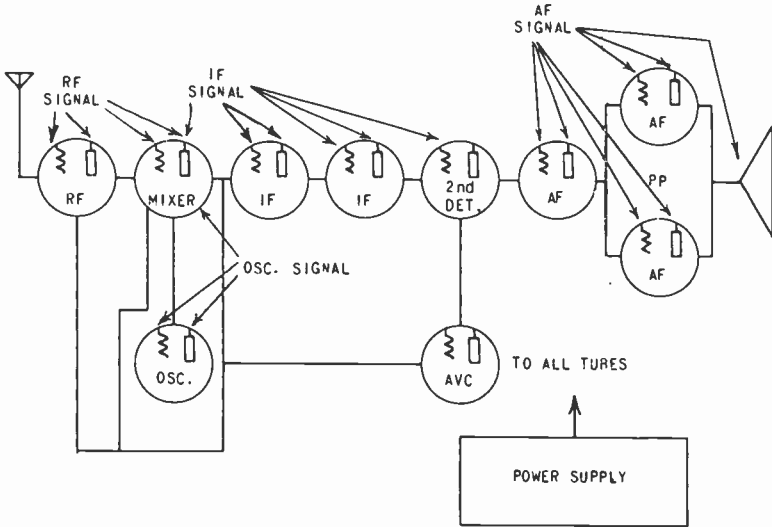

Fig. 2 Functional diagram of a superheterodyne receiver using AVC.

whether a signal is applied or not. Control voltages, on the other hand, are generated by the signal and, of course, are not present when no signal is being received. Examples of control voltages are those produced in AVC and AFC circuits. Now we must remember that the control voltages are DC and the most suitable instrument for measuring them is a vacuum tube voltmeter designed for that purpose. Such an instrument has a very high impedance and does not upset the circuit to which it is applied. Fig. 3 illustrates the basic points where the AVC control voltages should be measured.

2. PRELIMINARY TESTS. Frequently a receiver which has some major defect in the power supply is sent to the service shop. A filter condenser may be shorted; the transformer may be faulty; or there may be some short circuit between B+ and the chassis. If such is the case, the correct operating voltages will not be applied to the set and the quality of the signal as determined at

the basic points will not be a true indication of the set's capability. Furthermore, allowing the power to be applied for only a short time may cause the burnout of the power transformer, a filter choke, or some other component of the set. It is thus apparent that it is necessary to check each receiver for such defects in the power supply before the signal tracing itself is begun. This may be done in several ways; one which is particularly advantageous is the use of a wattage indicator which is provided in at least one of the commercial signal tracing instruments to be described later. The AC plug of the receiver is connected to the proper outlet on the instrument and the power consumption is read. Of course, if there is a short in the power supply, this will be indicated by an excessive power consumption. An ordinary wattmeter may also be used but care must be taken in its application, for if a direct short exists, the wattmeter may be damaged. In addition, it is possible to measure the DC output voltage of the supply and from the reading obtained estimate the condition of the supply.

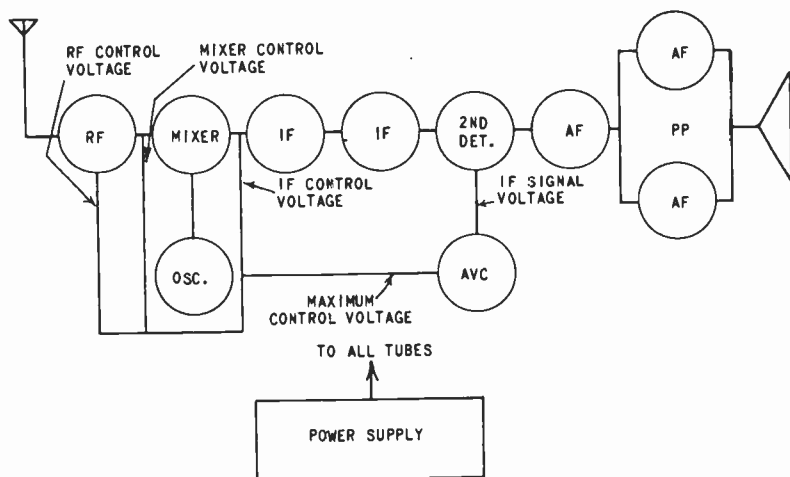

Fig.3 illustrating the measurement of control voltages.

Naturally any obvious defects such as noisy volume or tone controls should be corrected before the signal tracing is begun. Likewise, it is good practice to clean the wiping contacts on the rotors of variable condensers, and to make a casual inspection for loose wiring and poor ground connections.

3. THE SIGNAL GENERATOR. In order to trace the signal through the various stages of the receiver, it is, of course, necessary to have a signal source. When tracing for defects which would cause the receiver to be either inoperative or weak, the signal source should be a reliable test oscillator. This

oscillator should cover the intermediate frequency band, the broadcast band, and all of the short wave bands so that it will be suitable for use with all-wave receivers. It should have a stable frequency output, a dial which is easy to read, and should be provided with an attenuator by means of which the magnitude of the signal may be controlled within close limits. Furthermore, it is preferable that it be so designed that the percent of modulation can be varied. It is desirable, though not absolutely necessary, that the circuit be so arranged to permit the modulation of the oscillator's output with external audio signals.

When checking the distortion of the receiver, you will find that a broadcast signal is many times preferable to the output of the modulated signal generator. It is easier to detect distortion in music and speech than in single-tone modulation. For the noise, hum, or oscillation checks of a receiver, no signal source is necessary. Generation of the noise, hum, or oscillation provides the signal and it is the purpose of signal tracing to determine in just what part of the circuit this generation occurs and then take what steps may be necessary to eliminate it.

Ordinarily, a signal of 600 kc is used for general signal tracing; however, in some instances you will find that when you attempt to use this frequency, a local broadcast station may produce interference. If this happens, then some frequency slightly above or below 600 kc may be used during the signal tracing process. It is desirable that a low frequency signal be chosen for with the set tuned to a low frequency, the tuning condensers are at maximum capacity and the small capacity of the test probe then has the least effect upon the receiver's circuit.

It is customary to use this frequency of 600 kc on both broadcast and all-wave receivers. If it is found that the trouble exists on all bands of an all-wave receiver, then the locating and correcting of that trouble in the broadcast band, in many instances, will eliminate the trouble on all bands. Sometimes the defect exists only in one or more of the short-wave bands. When this happens then it is evident that the defect exists in the RF mixer or oscillator circuit and these components may be checked by such methods as will be outlined later in this lesson.

**4. DEAD RECEIVERS.** To illustrate the general procedure for signal tracing, let us assume that we have a dead receiver; a receiver which, due to one or more defects, has no signal output. For purpose of explanation, we will consider the receiver whose diagram is illustrated in Fig. 4. This is a 6-tube superheterodyne receiver with AVC. It does not have an RF stage, the signal being delivered directly from the antenna into the mixer tube.

Before making any signal tracing checks, we must first perform a power test to make certain that the receiver is not dead because of a shorted power supply. Assuming that this test has been made, and that the power consumption of the receiver was found to be normal, we are then ready to start the signal tracing.

The first step is to connect the signal generator to the antenna and ground post of the receiver. It is desirable, though





not absolutely necessary, that a dummy antenna be used between the signal generator and the receiver's input. This dummy antenna may be the same as would be used for ordinary alignment purposes. The signal generator and the receiver are now both tuned to 600 kc. To make certain that the signal is actually being applied to the receiver, the tuned vacuum tube voltmeter is set at 600 kc and the test probe is touched to the antenna post of the receiver. The attenuator of the signal generator is then adjusted so that an easily remembered indication is obtained on the vacuum tube voltmeter. This indication is to be remembered as the reference level. It is possible that there will be no indication on the vacuum tube voltmeter when we make this check. Let us refer to Fig. 4 and determine just what condition would prevent an indication on the voltmeter. The test probe is connected to point 1 (illustrated in Fig. 4), and it is seen that if the primary of the antenna coil is shorted there would be a direct connection between the antenna and ground post and, consequently, no reading could be obtained. If such condition is encountered, it must, of course, be corrected before proceeding.

It is possible that the primary of the antenna coil is open and in that case a reading would be obtained on the vacuum tube voltmeter, but this particular defect would be found at our next check point. When the probe of the vacuum tube voltmeter is placed on point 2, a signal somewhat stronger than that obtained at point 1 should be indicated. The actual gain in the antenna transformer is not of great importance at this time because we are checking for a complete disappearance of the signal. If there is no signal present at point 2, then we should suspect a shorted tuning condenser or trimmer condenser, internal tube shorts, or an open primary or secondary winding in the antenna transformer. If no signal is indicated at point 2, it will then be necessary to make resistance checks to determine which component is defective.

Assuming that a signal is present, we pass on to point 3. The signal at this point is the output of the oscillator and should have a frequency equal to the signal frequency plus the intermediate frequency. Therefore, it is necessary that we retune the vacuum tube voltmeter to the oscillator's frequency. If we assume that the intermediate frequency of this receiver is 455 kc, then the oscillator signal should be 1055 kc. The vacuum tube voltmeter is tuned for greatest indication with the test probe connected to point 3 and since the vacuum tube voltmeter has a calibrated frequency scale, we can determine whether or not the oscillator frequency is correct. If it deviates greatly from the proper value, it is evident that the defect lies in those circuits affecting the tuning of the oscillator and they should be checked individually.

Should the oscillator frequency be considerably below 1055 kc, a possible cause would be a shorted padding condenser. If it is considerably above 1055 kc, it may be due to an open oscillator coil or loosened turns on the oscillator coil. An open padding condenser will also cause the oscillator frequency to be

high. Having determined that the oscillator is functioning correctly, we now proceed to test the signal at points 4, 5, 6 and 7. The signal present at these points would be the intermediate frequency and so it is necessary to retune the vacuum tube voltmeter to this frequency.

If we find a signal present at point 7 (the second detector diode plate) we are assured that the RF oscillator, mixer, and IF circuits are functioning normally. During actual receiver servicing, considerable time may be saved by checking the receiver in sections. Instead of starting at the antenna and checking each successive stage, the second detector would be checked first. If no signal is found at that point, there is no need of checking the audio circuit. If there is a signal present at that point, it is then only necessary to check the audio stages to find the defect which is preventing the receiver from functioning normally. This sectionalizing test applies to all receivers with or without AVC.

Having followed the signal through the mixer, oscillator and IF sections of the receiver, we are now prepared to check the audio frequency amplifier. For determining the presence of an audio signal, the tuned vacuum tube voltmeter which we have been using will be of no value to us. We must, therefore, use a vacuum tube voltmeter designed particularly for audio frequency work. It must, of course, have an input impedance large in comparison to the circuit under test. Suitable equipment for making these tests will be described in later sections of this lesson.

The probe of the audio vacuum tube voltmeter is connected first to point 8, illustrated in Fig. 4. Should there be no audio signal at this point, it then becomes necessary to check the components of this particular circuit. Assuming that an audio signal was found at point 8, we now proceed to point 9. A signal present at point 8 but not at point 9 would indicate an open coupling condenser. (C20 in Fig. 4). Likewise, a shorted condenser in this position would give no signal indication at point 8. Point 10, the plate of the output tube, is our next check point. No signal present at this point would indicate an open or shorted plate winding in the output transformer, an open bias resistor, or a shorted bypass condenser (C21). If the signal is present at point 10 but not at point 11, it is evident that the speaker or the output transformer is defective and we must make the usual continuity check.

5. SIGNAL TRACING IN WEAK RECEIVERS. If the receiver which we are servicing has a signal at the output but the volume is low, we can be certain that the signal is present at all points but that some component is not operating at full efficiency.

The first check, as with the inoperative receiver, is a power test. A power over-load such as caused by a partial short in some part of the power supply system will be indicated in this test and would be sufficient to cause the weak output. If the power test shows no great discrepancy, we proceed with our signal tracing at the same points as in our test on the dead receiver.

In the test on the inoperative receiver, it was mentioned that we were not interested in the gain per stage. This, however, is not true in the testing of weak receivers. It is evident that the weak output is due to a subnormal gain in one or more stages and, thus, to locate the difficulty we must check the gain of each stage of the receiver. In modern servicing it is not necessary to have exact reading of the gain per stage. The present day broadcast receiver has been designed with a far greater sensitivity than is required, consequently a weak receiver will have one or more stages of exceedingly low gain or with an actual loss rather than a gain. The exact gain per stage varies widely in different receivers; however, the gain per stage table given below is close enough for all practical purposes.

#### RF SECTION

Antenna to grid first tube.....	2-10
Amplifier - superheterodynes.....	10-40
Amplifier - TRF .....	40-100

#### MIXER SECTION

Converter to IF grid (1 stage IF).....	30-60
Converter to IF grid (2 stage IF).....	5-30

#### IF SECTION

IF stage (1 stage IF).....	40-150
IF stage (2 stage IF).....	5-30

#### AUDIO SECTION

Medium Mu Tubes.....	20-25
High Mu Tubes.....	40-60
Output Pentodes.....	8-20
Output Triodes.....	2-5

It is suggested that after repairing a receiver the gain per stage be recorded on the schematic diagram of that receiver for future reference.

Referring again to Fig. 4, let us connect the test oscillator to the antenna and ground post of the receiver. A 600-kc signal, modulated at an audio frequency, is applied to the receiver. With the test probe on point 1, the signal generator attenuator is adjusted so that our output indicator is just at the reference level selected in the test for a dead receiver. When the test probe is moved to point 2, a gain should be indicated (even if no power is applied to the receiver), and the gain between points 1 and 2 should fall between 2 and 10.

If we find that a loss instead of a gain is indicated at point 2, it may be due to loading of the secondary or to an open secondary coil. The secondary may be loaded because of the shorting of bypass condenser C7. This allows grid current to flow on a strong signal, thus loading the secondary circuit. Capacity effects will allow a weak signal to pass through the transformer in case of an open secondary coil. This would give a weak signal indication at point 2. Continuity and resistance checks will find the actual trouble.

Assuming that a normal gain is found at point 2, we next check the IF signal at point 4. We must, of course, tune our vacuum tube voltmeter to 455 kc during this test. The IF signal at this point should be stronger than the RF signal at point 2 due to the gain in the mixer tube. AVC action, however, will limit the mixer gain. If no gain is noted, the AVC voltage should be checked as explained later in this lesson. A loss rather than a gain at this point may be due to several causes. Among these are misalignment, incorrect voltages on the mixer tube elements, open screen bypass condenser, low oscillator voltage or defective mixer tube.

We next check our signal level at point 5. We find that there is no gain at this point over point 4 and often a small loss will occur. A large loss, however, indicates some defect in the coupling circuits. Again, it may be due to misalignment or the secondary winding may be open or shorted.

We next check the IF signal at point 6. The magnitude of the signal at this point should be considerably greater than at point 5. The actual gain should be within the limits given in the preceding table. Less than normal gain, or an actual loss, indicates some defect in this IF stage and the components of this stage must be checked separately. The signal at point 7 will probably be less than at point 6 by as much as 2 or 3 to 1. This decrease is caused by the loading effects of the diode on the secondary of the IF transformer.

If the signal tracing has discovered no defects up to this point; that is, if all of the gains have been within reasonable limits, we know that the audio section of our receiver is at fault.

Our first step in checking the audio section is to set up a reference level. With the signal generator connected to the antenna and ground post and with the modulated signal being fed to the receiver, the test probe of the audio vacuum tube voltmeter is connected to point 13. The sensitivity of the audio vacuum tube voltmeter is set at maximum and the attenuator of the signal generator is adjusted until a convenient reference indication is obtained. The test probe is now moved to point 12 and the output indication should remain approximately the same. A considerably weaker indication could be caused by a short in the tube or by a shorted bypass condenser.

Assuming that a normal signal is obtained at point 12, we now touch the probe to point 8. We should expect a gain in accordance with the table previously given dependent upon the  $\mu$  of the tube. Low gain at this point could be caused by a defective tube, shorted coupling condenser C-20, incorrect bias or plate voltage, or some trouble in the plate load circuit.

The signal level at point 9 should be approximately the same as at point 8. A large drop in the signal could be caused by an open coupling condenser, a defective power tube which would cause grid current to flow, or a shorted bias resistor in the power tube circuit.

The next check point is #10. There should be a gain at point 10 above that of point 9, dependent upon the type of power tube used in the receiver. The gain, however, will be much less than in previous stages. This is due to the fact that a power tube never has a great deal of amplification but rather is for the purpose of furnishing enough power output to operate the speaker satisfactorily. Since a step-down transformer is used to couple the power tube to the speaker, the signal level at point 11 may be considerably lower than that at point 10. This is normal, however, and is not an indication of some defect in the receiver.

Low gain or loss of signal at point 10 might be caused by a faulty output tube, incorrect voltages, or a shorted transformer secondary. If the signal is normal at the last point tested, the trouble must lie in the speaker, either in the voice coil or field winding. The field of the speaker may be tested by touching a screwdriver to the pole piece of the speaker. If the field is normal there will be a strong magnetic field which can be noticed by the pull on the screwdriver. Some care must be taken in this test for the magnetic pole may deflect the screwdriver and thereby damage the cone.

6. NOISE TRACING. In tracing noise in the receiver, no signal generator is required; for the noise itself serves as the signal. Instead of tracing a signal from the signal generator through the receiver to find where it departs from normal, we check the same points without a signal and find at which point the noise first appears. It is customary to trace noise by a listening test using a pair of headphones plugged into the output jack of the vacuum tube voltmeter. By this method it is possible to compare the noise in the headphones to that heard in the loudspeaker and thereby have positive identification of this signal.

Noise testing procedure is the same as that followed for inoperative or weak receivers. The tests are continued until the noise is first heard. In checking the IF and RF sections, the tuned vacuum tube voltmeter is used; whereas, in checking the power supply and the AF section, an audio frequency vacuum tube voltmeter is employed. If, in these checks, we first find noise at a plate terminal, we then check the noise at the B+ terminal. If the noise level is the same at both points, the trouble lies in the B supply and it should be checked for noise.

In receivers employing AVC circuits, it is possible to make a general localization of the noise source. If the noise level is the same at both maximum and minimum settings of the volume control, the noise source is somewhere in the audio frequency section of the receiver or in the power supply. On the other hand, if the noise is at minimum or disappears at minimum volume control setting, then the noise source lies somewhere in the RF or IF section of the receiver under test.

If the noise is found at the plate of a tube but not at the grid, it is very possible that the tube is defective. This can be checked by replacing the tube. Very often in transformer-

coupled stages the winding of the transformer may become corroded due to electrolysis. This trouble can be easily located once the tube has been eliminated as a source of trouble. If the noise level is greater at the plate terminal of the tube than at the B+ side of the transformer, the transformer is at fault and should be replaced. This test applies to both primary and secondary of RF, IF, and audio transformers.

7. HUM TRACING. As in the tracing of noise, it is not necessary to use a test oscillator for locating the source of excessive hum. Either headphones or a cathode ray oscilloscope may be used as the indicating instrument and one or the other is plugged into the output jack of the AF vacuum tube voltmeter. Since the power supply is the most likely source of hum, it should be tested first. A wattage consumption test is first made on the receiver and if it is found to be within reasonable limits, then the filtering efficiency of the filter system can next be checked.

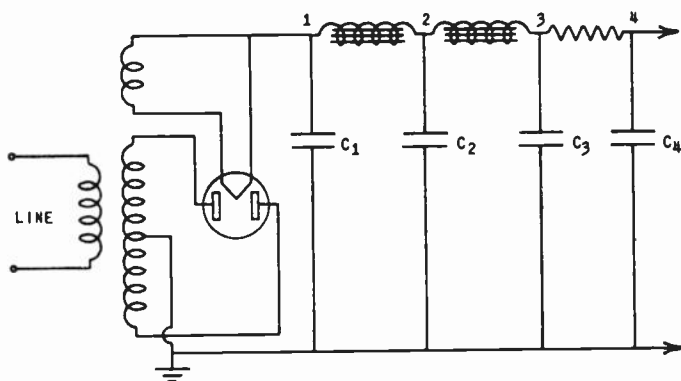

Fig. 5 Illustrating the test points in a power supply.

To obtain a reference level, we place the probe of the AF test instrument at point 1 in Fig. 5. The input control of the test instrument is adjusted until a moderate tone is heard in the headphones or indicated on the oscilloscope.

The hum level at point 2 is checked next. It should be a great deal lower. If the hum level at point 2 is the same as at point 1, it is possible that filter condenser C2 is open. A shorted condenser would have been found in the power overload or wattage consumption test. A shorted choke between points 1 and 2 could also cause this trouble. The hum level is checked at each succeeding point until the defective part is located.

It is impossible to set a hard and fast rule as to hum level in all makes of receivers. In midget models, the design engineer can purposely use less filtering to cheapen the design; however, due to the small cabinet and the limited response of the speaker used, the increase in hum is not noticeable. In the larger

models, console and massive cabinet types, the filtering must be efficient because the speakers and cabinets give a far better reproduction of the low-frequency notes.

We have discussed hum which has its source in the power supply system. Such hum is distributed throughout the entire receiver and is objectionable whether the signal is being received or not. Hum may also be due to poorly adjusted hum balancers that are used across the filaments in older filament type tubes. Defects from this source can be located in the same manner as described for locating noise. These units should be adjusted before proceeding with the other hum tests. If adjustment does not help, each hum balancer should be checked for partial shorts or open with an ohmmeter.

Other sources of hum are shorted tube elements, poor ground connections, leaky coupling condensers, or shorted hum-bucking coils. Hum is sometimes caused by a carrier signal due to some defect in the RF circuit. Such defects are traced by the same method as noise tracing using an unmodulated signal input to the receiver. Defective screen bypass condensers are also a source of hum trouble.

8. DISTORTION TRACING. In signal tracing for distortion, either headphones of a cathode ray oscilloscope may be employed. With headphones it is possible to use a broadcast signal since it is easier to distinguish distortion in music and speech than in a 400-cycle signal. As an alternative, it is possible to use a signal generator and modulate that signal with speech or music from a record by means of an electrical pickup and amplifier. When the oscilloscope is employed to trace distortion, a single-tone modulation such as is available for most test oscillators is required. The modulation in this case must be substantially free from distortion.

In using the oscilloscope, the receiver under test is set up exactly as in signal tracing. Instead of checking the signal level at each point progressively through the receiver, the waveform is examined at each point and compared with the waveform at the initial point of check. When a difference in waveform is noted, the components of the circuit under test are checked for defects. In using the oscilloscope with the tuned vacuum tube voltmeter and the isolating probe, it is possible to test for distortion without upsetting the circuit under test.

To obtain a reference waveform, the signal generator is set at 600 kc and a modulated signal is fed to the receiver. The oscilloscope is plugged into the output jack of the vacuum tube voltmeter and the test probe is placed at point 1 in Fig. 4. The oscilloscope controls are then adjusted until the signal is synchronized and an image of convenient height appears.

The waveform is now checked at progressive points. At each point the signal should become stronger and the image on the oscilloscope should increase in height. To compensate for this increase in height, do not change the oscilloscope control, but change the vacuum tube voltmeter control or the signal generator



attenuator. On receivers using AVC, it is important to keep the input signal as strong as conveniently possible as the distortion may be due to some defect in the AVC circuit which is inoperative on weak signals. After locating the circuit in which distortion is first noticeable, we must again check the components for shorts, opens, or other defects.

When using headphones for distortion tracing, the reference signal is obtained as before. The volume control should be set at minimum so that the loudspeaker will not mask the headphone signal. The reference signal can be a clear, although weak, signal as picked up by the receiver antenna while a broadcast program is being received. Constant signal level is maintained by adjusting the vacuum tube voltmeter as progressive checks are made through the receiver. It is only necessary to return frequently to the antenna post to check the reference signal.

Distortion tracing in AF circuits is accomplished by using either headphones or a cathode ray oscilloscope in conjunction with an AF vacuum tube voltmeter. The reference signal is found at point 13 in Fig. 4. If distortion is discovered at this point, there must be some trouble in the diode load circuit. Distortion characteristics at point 12 should be the same as at point 13. Further reference points are 8, 9, and 10. As a rule, distortion in AF circuits is found to be due to lack of grid bias on one of the AF tubes or to gassy tubes.

9. OSCILLATION TRACING. The RF, IF, or AF sections of a receiver may be the source of oscillation. It may occur as a result of incorrect operating conditions in a single stage or because of coupling between two or more stages. When oscillation occurs in a single RF stage, the oscillation is usually heterodyned by the set oscillator, creating an IF signal which may find its way through the IF amplifier and possibly into the AF stages. From all appearances, it would seem that the entire receiver is oscillating. In like manner, oscillation occurring in a single RF stage can affect the entire IF and AF amplifiers.

When oscillation occurs in a radio receiver, the tuning condenser should be rotated throughout the tuning range and any change in the oscillation should be noticed. If no change occurs, then it is most likely that the oscillation is occurring in the IF stages which would not be affected by the setting of the tuning condenser. On the other hand, when the oscillation occurs in an RF stage, it is found that the oscillation will be stronger at some points of the tuning dial than at others, or that the oscillation will occur at one end of the tuning band and not at the other end.

In many instances, the oscillation is present only when the receiver is supplied with a signal. When this happens, a test oscillator or signal generator may be used to supply the signal so that the set can be tested under the same conditions as those under which it normally operates.

Before starting the tracing of the oscillation, there are a few preliminary servicing adjustments that should be made. Make

certain that the condenser gang is clean and that connections are tight; check for corroded ground connections; check the tubes and make a quick check to see that there are no glaringly obvious defects. It is also necessary to watch that the antenna lead does not run close to the amplifying stages or tubes of the receiver. It is very possible for energy to be fed back to the antenna wire while the set is in normal operation and yet no oscillation will occur when the antenna lead-in is removed.

Let us first assume that the oscillation is present in either the RF or IF stages with no applied signal. The probe of a vacuum tube voltmeter is touched to one of the points in the RF or IF sections where the oscillation is present and the frequency of the oscillation is then determined by tuning the vacuum tube voltmeter for greatest output. Then the test probe of the vacuum tube voltmeter is placed on each grid and each plate until the point of strongest indication is found. If there is only one stage oscillating, then the strongest signal is usually found at this stage.

When oscillation occurs due to common coupling between stages, then the relative signal strength caused by the oscillation will not prove an accurate guide in localizing the source. It is, however, relatively easy to determine the source of oscillation even when it is caused by common coupling. The test probe is touched to some point in the receiver where the oscillation is present and a condenser of approximately .1 mfd. capacity is then connected between the grid of each tube and ground, in turn, until the oscillation stops. When this point is found, then coupling is taking place between the tube under test and the tube whose grid is grounded by the .1 mfd. condenser.

Those components or circuits which are common to each of the oscillating stages must now be checked, giving particular attention to ground connections, misplaced leads, loose coil shields and open bypass condensers.

10. CHECKING AUDIO OSCILLATION. Oscillation in the audio stages of a receiver usually takes the form of motorboating or intermittent blocking. It is commonly caused by defective decoupling of the filter circuits in the power supply. It can, however, be caused by open grid circuits in amplifying stages or by the improper placement of leads of component parts. If motorboating is present with no applied signal, ground or short circuit the control grid of one of the AF tubes so that the motor-boating stops. Next, test the condensers in the power supply and the decoupling circuits, looking particularly for open condensers. When any bypass or filter condenser is open, the filtering action is, of course, greatly reduced and relatively high hum level will be noted at the point which is normally bypassed. To check for open grid circuits, shunt a resistor corresponding to the value commonly used, from each grid in turn to ground, or to its normal return point. The trouble will disappear when the resistor is shunted across the grid circuit that is open.

In some cases oscillations are found in pentode and beam power output circuits. In many instances the oscillation will be

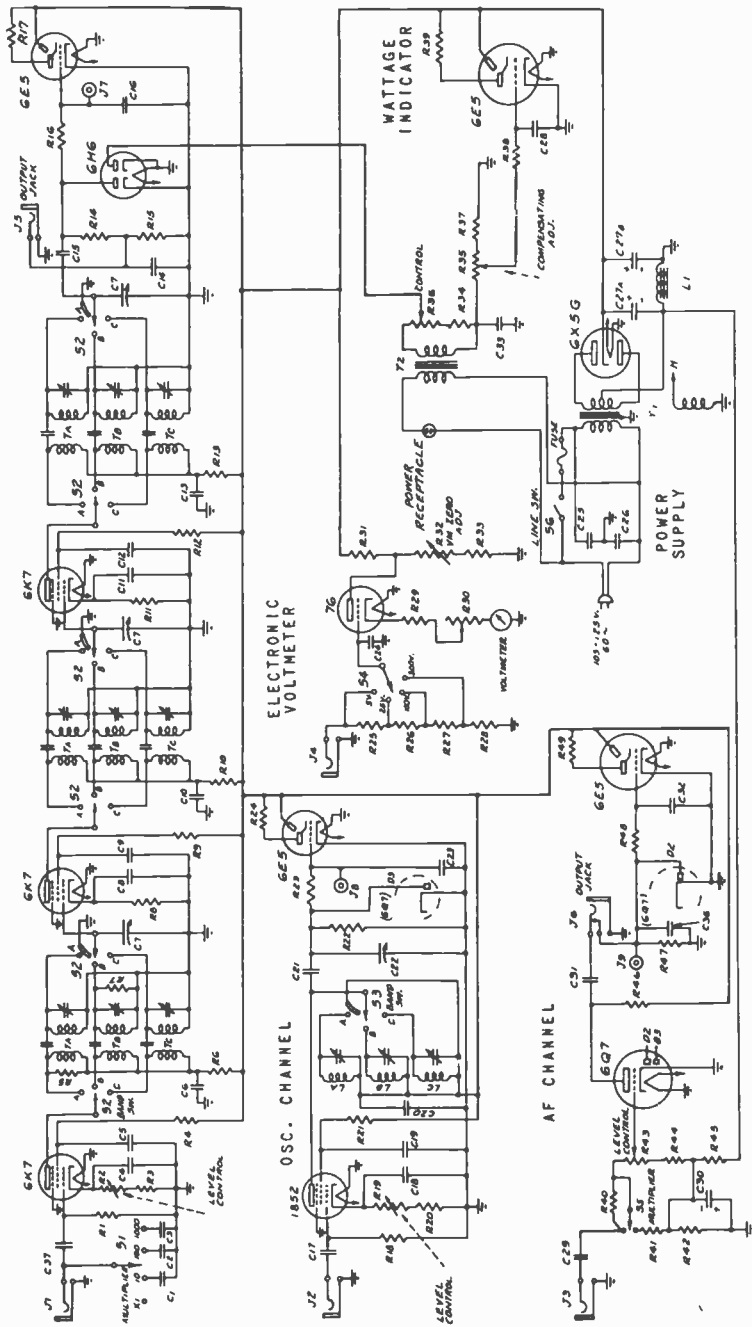

Fig. 6 Schematic diagram of the Chanalyst.

above the audible limit and so should be checked with the vacuum tube output indicator rather than the headphones. A high signal voltage will be indicated on the indicator when the test probe is placed on the grid or plate terminal of the affected tube. The plate bypass condenser and filter components of the stage should then be checked after making certain that the tube itself is not defective.

11. SIGNAL CHECKING IN TRF RECEIVERS. The method of procedure for signal tracing of the RF stages of a superheterodyne applies equally well to TRF receivers. It must, however, be realized that in a multi-stage TRF receiver, regeneration is often present which will affect the gain-per-stage measurements. In some cases, regeneration is purposely added to increase the gain and thereby improve the sensitivity without adding additional amplifying stages. When this is the case, a regeneration control of some type will be incorporated and it is necessary to make certain that this regeneration control is so adjusted that the regeneration is at minimum during the signal tracing process. Many TRF receivers have some regeneration even when operating normally due to imperfect shielding and unavoidable coupling.

When a signal generator is connected across an RF stage in order to obtain the gain of that stage, the circuit shunted is very heavily loaded and, in most cases, any regeneration is eliminated, but the actual gain which is measured is less than that present when the signal generator is disconnected from the circuit. Even the vacuum tube voltmeter causes some shunting effect; although in most cases the probe of this instrument is so designed as to produce a minimum of loading. This point, however, makes very little difference to the serviceman. He is not interested in obtaining the exact gain per stage measurement but rather his purpose is to find the trouble which affects the magnitude or quality of the signal. Therefore, realize that the gain which you may measure in an RF stage is not necessarily critical and you should watch for wide deviation from expected results.

12. THE CHANALYST. The first part of this lesson has dealt with the basic principles and procedure of signal tracing. Many of the instruments such as vacuum tube voltmeters, ohmmeters, oscilloscopes, etc., have been described and their operation explained in previous lessons. In the past few years, however, there has been placed on the market several instruments which include all of the equipment needed for signal tracing. One such instrument which is entirely self contained is called the Chanalyst.

Some of the purposes for which this instrument is suitable are as follows:

1. For checking the power consumption of radio receivers.
2. For feeding a signal of known frequency across the antenna-ground terminals into a receiver.
3. For checking the passage of this signal through the RF,

IF, and audio systems of the receiver under test and at the same time determining whether the set oscillator is functioning properly or not.

4. For measuring the DC voltage at any point in the receiver including control voltages such as developed in AVC or AFC circuits.
5. To detect the source of hum, distortion and causes of oscillation in radio receivers.

In order to accomplish the above tests, five separate electrical circuits are used. These are shown on the schematic diagram illustrated in Fig. 6. For the present we will consider these names only as a means of identification during our discussion and we should understand that these names do not describe fully the operating scope of the circuits so named. These five electrical circuits are known as:

1. The RF-IF channel.
2. The wattage indicator.
3. The oscillator channel.
4. The audio frequency channel.
5. The DC electronic voltmeter.

13. THE RF-IF CHANNEL. From Fig. 6 we can see that the RF-IF channel consists of a 3-stage RF amplifier whose output feeds a diode detector and an electron ray indicator tube. This complete circuit constitutes a 3-band receiver tuneable from 95 to 1700 kc. This range is sufficient to cover the IF band of modern receivers and the standard broadcast band. The frequency bands are divided as follows:

- A band - 95 kc. to 260 kc.
- B band - 240 kc. to 630 kc.
- C band - 600 kc. to 1700 kc.

Fig. 7 shows a photograph of the Chanalyst with the various channels, controls, and jacks marked.

The jack labeled J-1 on the schematic diagram is located at the lower left corner of the front panel. The specially designed RF-IF cable plugs into this jack. This cable has at its other end a probe tip which assists in the testing of receivers.

It may be seen from the schematic diagram that the RF-IF channel constitutes a complete TRF receiver, the 6E5 electron ray tube being used as the final output indicator. The electron ray tube indicates by changing its shadow angle. When no signal is applied to the input of the RF-IF channel, the shadow angle is maximum. The application of a signal causes the shadow angle to decrease (the eye to close); the larger the input signal, the smaller the shadow angle becomes. If the input voltage is sufficiently large, the eye "overlaps". The amount of shadow angle can be changed by varying the signal voltage at the input of the channel.

The RF-IF channel also includes a level indicator and multiplier used in conjunction with the electron eye for indication of



signal strength. A calibrated range of 1000 to 1 is available. The level control is continuously variable throughout a range of 10 to 1, whereas the multiplier covers a range of 1000 to 1 in steps which vary by a factor of 10.

In general, the operation of the RF-IF channel is as follows: Suppose, for example, that it is desired to compare the magnitude of two voltages of like frequency. For the sake of argument, let us assume that the frequency of these voltages is 600 kc. although any frequency in the range of the instrument will do just as well. Designating one voltage as A and the other as B, the first step is to establish a reference indication upon the eye for one of the voltages. Let us assume we choose the weaker of the two. Voltage A (which we assume is the weaker) is fed into the channel by means of the RF-IF probe and this channel is tuned for maximum indication on the tuning eye (that is, minimum shadow angle).

The next step is to adjust the multiplier and lever control until the eye just closes. Suppose, for example, that this occurs when the multiplier is at 1 and the level control at 4. The reference for this voltage would be  $1 \times 4$ , or 4.

Voltage A is now removed and voltage B is applied. Once more the level and multiplier controls are adjusted until the RF-IF tuning eye indicator just barely closes. Let us assume that in order to cause the eye to close, the multiplier must be at 10 and the level control at 8. The arbitrary level for this voltage would then be  $10 \times 8$ , or 80. The ratio between the two voltages would be the ratio of 80 to 4 or the second voltage B is 20 times larger than the first voltage A.

Some of the uses of the Chanalyst are as follows:

1. It may be used as a conventional broadcast receiver. A pair of high impedance headphones are plugged into the output jack J5 in Fig. 6, or this output can be amplified by an audio amplifier if more power output is desired. The audio channel of the Chanalyst may be used for this purpose.
2. The Chanalyst may be employed as a field intensity meter or for comparing the strength of two different broadcast signals.
3. It may be used to determine the approximate frequency of any unknown signal (assuming that the unknown frequency is within the range of the instrument).
4. It may be used to determine whether an antenna has sufficient signal pickup to make a set operate normally.
5. For establishing the relative strength of a signal at various points in a radio receiver, the Chanalyst may be used as a tuned vacuum tube voltmeter.
6. It may be used to determine the presence, absence, or level of signals in a radio receiver at those points where the signal should exist and also at those points where the signal should not exist.

7. It may be used to listen to the signal in conjunction with a pair of headphones or to look at the signal in conjunction with a cathode ray oscilloscope.
8. To determine the origin of extraneous noises originating in the RF or IF stages of a receiver.
9. To indicate the presence of oscillation occurring in an RF or IF stage.

14. **THE OSCILLATOR CHANNEL.** By referring to the photograph illustrated in Fig. 7 and the schematic wiring diagram shown in Fig. 6, you will be able to determine the controls associated with this channel. It is seen that it consists of a single stage, 3-band, tuned radio frequency amplifier which operates into a diode detector and an electron eye indicator. Its frequency range is from 600 kc to 15,000 kc in 3 bands as follows:

Band A - 600 kc to 1700 kc.

Band B - 1650 kc to 4900 kc.

Band C - 4800 kc to 15,000 kc.

The input jack labeled J2 in the schematic diagram is shown in the photograph of the instrument in the lower right-hand corner of the assembly of the oscillator channel control directly beneath the on-off switch. There is a small pin jack located to the left of the oscillator channel input jack which allows the electronic voltmeter to be connected to the control grid of the oscillator channel indicator tube. In general, the oscillator channel is similar to the RF-IF channel but it operates over a different frequency range and is less sensitive.

The primary purpose of this channel is to determine the condition of the oscillator of the set, to determine whether it is functioning and whether it is tuning over the proper range or not. Since this is so, it does not need the sensitivity required by the RF-IF channel. The main purpose of the level control is to enable correct tuning of the oscillator channel. If, as the oscillator channel is tuned, the eye tends to overlap, then the gain of the channel should be reduced by the level control so that correct tuning will be possible.

A few of the possible uses of the oscillator channel are as follows:

1. To compare the signal voltage levels from different oscillators.
2. To determine the frequency of the voltages developed by the oscillator in a superheterodyne.
3. For qualitative comparison of voltages which are in excess of .1 volt in which case the channel is used as a tuned vacuum tube voltmeter.
4. For checking or monitoring the oscillator output of the receiver particularly during a check for intermittent trouble.
5. For monitoring the frequency and voltage level of signal generators.



15. THE AUDIO FREQUENCY CHANNEL. The audio frequency channel consists of a one-stage resistance-coupled audio amplifier whose output is rectified by a diode detector and then fed to a tuning eye. There also is provided an output jack into which a pair of headphones may be plugged. The location of the AF channel can be seen on the schematic diagram in Fig. 6 and also in the photograph of Fig. 7. Associated with this channel is a level control and a multiplier. The input jack is J3 and is located at the bottom of the panel in Fig. 7. An oscilloscope may be plugged into the output jack J6 if it is desired to make the waveform visible; or to feed the output of the channel to some external audio amplifier for further amplification.

When either headphones or any other device is plugged into this output jack, the electric tuning eye, together with its diode rectifier, is automatically disconnected.

It is possible to use this channel for comparing the relative strength of two AF voltages. The electric tuning eye is the reference indicator. The channel has a sensitivity of approximately .15 volt. One AF voltage is fed to the channel by means of the probe provided and the multiplier and level control are adjusted until the indicator eye just closes. The reading of the multiplier and level control are then noted. Next, the second AF voltage is fed to the channel and once more the level control and multiplier are adjusted to cause closing of the eye, and their readings are again noted. Suppose that the reading in the first case was 1 on the multiplier and .5 on the level control, whereas, the reading in the second case was 100 on the multiplier and .4 on the level control. The total reading in the second case would then be  $100 \times .4$  or 40 and the gain would be  $40 \div .5$  or 80 times.

A blocking condenser is located at the input of the AF channel to prevent the application of DC voltages to the tube. This condenser, labeled C29 in the schematic, will block all voltages up to 1,000 volts. The channel has a very high impedance input in the neighborhood of 2,000,000 ohms and the probe may be touched to grid as well as plate circuits of audio stages without loading or interfering with the normal operation of the audio amplifier.

Some of the uses of the AF channel are as follows:

1. The channel may be used as a high gain amplifier with a flat frequency response over the high fidelity audio range, thus the output of the RF-IF channel may be amplified by the AF channel.
2. As an audio amplifier to couple separate audio amplifiers, or some audio source and a separate audio amplifier.
3. To check the various audio voltage levels throughout the audio system of a receiver.
4. To provide a means of listening to, or visually observing, the audio signal of different parts of the audio amplifier system of a receiver.
5. For determining the presence and source of hum voltages.
6. For determining the source of noises which may be generated within the audio system.

16. THE ELECTRONIC VOLTMETER. This channel, unlike the other channels, does not use an electric tuning eye for an indicator but rather employs a DC vacuum tube voltmeter circuit which operates a meter. From the schematic diagram in Fig. 6 and the photograph in Fig. 7, the location of this channel can be determined. The meter used in this channel has zero at mid-scale and will deflect in either direction from this mid-scale zero point, depending upon the polarity of the voltage applied to the test probe. Thus, there is no need to reverse leads when changing the probe from a point whose voltage is negative with respect to ground to one which is positive. All DC voltages within a receiver may be measured by this channel. This includes control voltages such as those developed by AVC or AFC systems as well as the normal operating voltages. Voltages may be measured with respect to ground or with respect to the free common lead which does not necessarily need to be at ground potential. The meter has four ranges calibrated as follows:

- 5 volts to 0 to 5 volts
- 25 volts to 0 to 25 volts
- 100 volts to 0 to 100 volts
- 500 volts to 0 to 500 volts

The meter has an exceptionally high input impedance in the neighborhood of 10,000,000 ohms and, therefore, will not interfere with the normal operation of the set when it is connected to any part of the receiver. Some of the uses of the electronic voltmeter are as follows:

1. To measure any voltage between 0 and 500 volts which may be either plus or minus with respect to any common point which need not be ground.
2. To measure rectified voltages within its range such as the DC voltage produced across a diode load or the bias voltage of an oscillator tube.
3. To measure normal operating voltages, such as screen grid, cathode, plate, etc., directly at these tube elements without changing or upsetting the normal operation of the circuit in any way.
4. The channel may be used to measure leakage voltages which sometimes occur in various radio devices.
5. To measure the voltage output of devices in which the permissible current drain is extremely low; such as the voltage developed by a bias cell.

17. THE WATTAGE INDICATOR CHANNEL. The purpose of this channel is to indicate the wattage consumption of the radio receiver or device to which it is connected. It will operate to show whether the wattage consumption is normal, above normal due to some shorts, or way below normal due to some open circuits. The location of this channel is illustrated in Fig. 6 and also Fig. 7. It consists of a current transformer, diode rectifier, and an electric tuning eye. The AC plug of the receiver under test is inserted into the receptacle on the back of the Chanalyst and

this places the current transformer in series with the AC input of the receiver. Also associated with this channel is the wattage indicator level control. It is calibrated in watts with respect to zero shadow angle. After the receiver has been connected, the level control is adjusted until the tuning eye just closes, at which time the scale of the level control indicates, within 10%, the power consumed by the receiver. Since most receivers operate at a power factor of approximately .8, the wattage indicator has been calibrated on that basis. When used in circuits where the power factor is 1, the reading of the level control should be multiplied by 1.25.

It is possible to determine the wattage consumption of a receiver very quickly and if an overload does exist, the receiver need not be kept connected to the power line long enough to cause any damage. The range of the wattage indicator is from 25 to 250 watts, which includes nearly all receivers.

18. OTHER USES OF THE CHANALYST. The previous information has provided a very general description of the use of the various channels in this instrument as well as the location of the various controls and their purposes. All of the circuits used with the Chanalyst imply a single free return or ground. This may be connected to the chassis of the receiver under test but may also be connected to any other point in the receiver for DC voltage measurements.

This ground is not connected to the primary circuits directly and, therefore, the Chanalyst can be used for checking AC-DC receivers as long as AC power is available for operation of the Chanalyst.

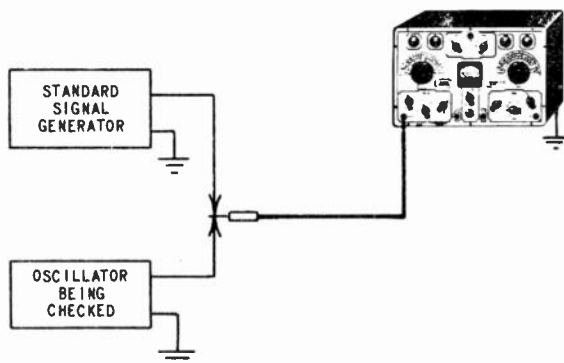

Fig. 8 illustrating how the Chanalyst is used to calibrate signal generators.

The general information given in the first part of this lesson applies to the operation of the Chanalyst in regard to its use in tracing noise, distortion, oscillation or checking a receiver which has become inoperative. There are, however, other uses to which the Chanalyst may be put and among them may be listed:

1. It may be used as a tuned radio frequency receiver: This may be done by plugging a pair of high impedance headphones into the output jack of the RF-IF channel and connecting a standard broadcast antenna to the probe tip of the cable used with this channel. The volume level is controlled by the level control and multiplier.
2. The Chanalyst may be used as a zero-beat indicator for calibrating signal generators: The method of connection is given in block diagram form in Fig. 8. Before the oscillator to be calibrated is connected, the Chanalyst is tuned to the standard frequency and the level control is set so that the shadow on the tuning eye is half closed. The oscillator which is to be calibrated is then connected to the probe tip and it is tuned accurately until the shadow of the tuning eye indicates zero beat. As zero beat is approached, the eye shadow will vary according to the beat frequency between the two oscillators. When the eye shadow no longer varies, zero beat is obtained. The oscillator may be calibrated at as many points as desired.
3. Alignment procedure with the Chanalyst: The Chanalyst may be used for broadcast receiver alignment and it is not necessary to rock the condenser gang at the lower frequency end of the range. Four sections of the Chanalyst are used for alignment. They are:
  - A. The RF-IF channel probe is connected to the mixer plate and the RF and mixer trimmer condensers may then be aligned, adjusting them for maximum output on the RF-IF tuning eye. In addition, the oscillator frequency up to 1700 kc. may be determined.
  - B. The oscillator channel, by means of which the oscillator operating frequency can be checked and adjusted up to 15 megacycles.
  - C. The electronic voltmeter which may be used to indicate when the AVC voltage is greatest.
  - D. The AF channel which can be used as a highly sensitive output indicator. It may be connected to any portion of the AF system for aligning receivers not equipped with AVC.

For aligning receivers which are equipped with an AVC system, the output of the signal generator may be either modulated or unmodulated, but an unmodulated signal is preferable since it ordinarily is sharper than when a modulated signal is used. The procedure to be followed is:

- A. Turn on the receiver, Chanalyst and test oscillator.
- B. Connect a clip lead from the stator to rotor of the receiver's oscillator tuning condenser to make the oscillating section inoperative.

- C. Tune the test oscillator to 1400 kc. and connect it to the input terminals of the receiver (or to whatever frequency is specified by the manufacturer for high-frequency alignment).
- D. Turn the tuning knob of the receiver until the exact alignment frequency is indicated on the receiver's dial.
- E. With the RF-IF probe on the receiver antenna post, tune the RF-IF channel for maximum indication.
- F. Connect the RF-IF probe to the mixer socket plate terminal.
- G. Adjust the trimmers on the gang condenser of the RF and mixer circuits for maximum RF voltage as indicated by the RF-IF channel indicator.
- H. Tune the RF-IF channel to the intermediate frequency of the receiver.
- I. Remove the shorting wire from the receiver's oscillating tuning condenser and adjust the oscillator trimmer for maximum I.F. voltage as indicated on the tuning eye indicator of the RF-IF channel.
- J. Tune the signal generator, the RF-IF channel and the receiver to 600 kc.
- K. Again make the receiver's tuning condenser inoperative (see step B).
- L. With the RF-IF probe once more connected to the mixer plate, retune the receiver until the 600 kc. signal voltage is maximum.
- M. Remove the shorting wire from the oscillator tuning condenser and set the RF-IF channel to the IF of the receiver and adjust the oscillator padding condenser for maximum IF indication.
- N. Since the low-frequency adjustment of the oscillator will slightly change the preliminary high frequency adjustment, once more tune the test oscillator and receiver to 1400 kc. and using a weak test signal, readjust the oscillator trimmer condenser until the IF signal at the mixer plate is greatest. To align the IF section of the receiver continue as follows:
- O. Connect the RF-IF probe to the first IF plate and adjust the trimmers of the first IF transformer for maximum IF output as indicated on the RF-IF channel tuning eye. Reduce the output of the test oscillator during this adjustment using just enough signal to note the effect of trimmer adjustments.
- P. Repeat this process for the next IF stage, connecting the RF-IF channel probe to the second detector diode if the set has only one

IF stage. Continue to reduce the output of the signal generator as the IF stages are brought into alignment.

4. Checking tracking on short-wave bands: The oscillator channel may be employed for checking the tracking on the short-wave bands after the receiver has been aligned according to the manufacturer's instructions. Proceed as follows:

- A. Tune in a signal whose frequency is known, one which is near the high-frequency end of the band.
- B. Measure the oscillator frequency of the receiver using the oscillator channel.
- C. Note whether the frequency of the oscillator is higher or lower than the signal frequency.
- D. Repeat the foregoing process for the low-frequency end of the band. The frequency of the receiver oscillator should bear the same relation to the signal at both ends of the band. If the oscillator frequency is higher at the high-frequency end of the band, it should likewise be higher at the low-frequency end of the band. In a like manner the tracking may be checked at intermediate points.

19. THE VEDOLYZER. The Vedolyzer is another instrument similar in type to the Chanalyst. It is shown in picture form in Fig. 9 and in schematic form in Fig. 10. Basically, the Vedolyzer contains three instruments. They are:

1. Cathode Ray Oscilloscope with high-gain amplifier.
2. Vacuum Tube Voltohmmeter.
3. Wavemeter.

As the use and operation of the Cathode Ray Oscilloscope has been covered in Lesson 2, we need not go into further detail at this point. One unique feature of this instrument is that it can be adapted to RF, IF or AF measurements with a minimum of operation.

Referring to Fig. 9, the Cathode Ray tube is located in the upper right-hand corner. The intensity and focusing controls are immediately to the right. Just below these controls are seven push-button switches marked "Sweep Frequency." Six of these are essentially band switches which control the frequency of the sawtooth oscillator that produces the horizontal sweep. Continual frequency control is obtained through the Fine control. The seventh button switches from internal to external sweep. The external sweep can be introduced through a suitable jack located at the bottom right of Fig. 9. All other controls, i.e. Horizontal and Vertical gain, Synchronizing Control and Vertical positioning controls are plainly marked.

The input to the amplifier is centered in the three jacks at the bottom center of the panel. The push-buttons immediately over these jacks are circuit-selecting switches.

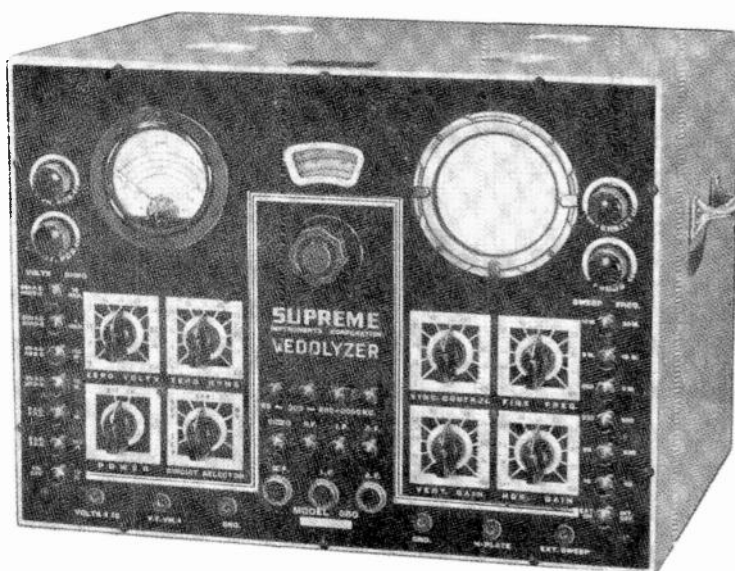

Fig.9 Photograph of the vedolyzer.

The wavemeter is essentially a tuned vacuum tube voltmeter. The tuning unit is located in the center of the control panel. There are three bands covering from 65 to 2050 kc as follows:

- Band A..... 65 to 205 kc.
- Band B.....205 to 650 kc.
- Band C.....650 to 2050 kc.

Band selection is obtained by means of the push-buttons immediately below the tuning dial.

The meter in the left upper center is the vacuum tube voltmeter. It has five scales. Reading from top down they are: ohmmeter, 6 volt DC, 2 volt DC, 9 volt AC, and 3 volt AC. The last two scales are also used for audio and radio frequencies. The ohmmeter reads, from left to right just like a voltmeter.

Just below the meter is a group of four controls. The upper left one, marked "zero volts" is used to "zero" the V.T. Vm. The upper right control in this group, marked "Zero Ohms" is for adjusting the V.T. ohmmeter. The lower left control of this group, marked "power" is the AC switch. The lower right control in this group, marked "circuit selector", is the voltmeter function selector switch.

The vertical row of seven push-buttons on the extreme left of the panel is the range selector switch for the vacuum tube voltohmmeter. The voltmeter ranges, both AC and DC, are to the





left of each button while the ohmmeter multipliers are to the right.

The input jacks for the vacuum-tube voltohmmeter are at the bottom of the panel to the left.

The right-hand jack is marked "GND" and is for the negative return circuit. The middle one "V.T. Vm+" is the regular positive input jack and is used for all AC, DC, and ohm ranges marked on the range selector switch. The jack, marked "VOLTS  $\times 10$ ", is used for DC volts only. When it is used, the ranges on the range selector switch and the input impedance are multiplied by ten.

The vacuum-tube voltmeter has an input impedance of 15 megohms, when using the low voltage input jack and 150 megohms on the high voltage jack. At 15 megohms there are six AC ranges: 0-3, 9, 30, 90, 300, 900 volts and six DC ranges: 0-2, 6, 20, 60, 200, 600 volts. There are also six DC ranges of 0-20, 60, 200, 600, 2000, 6000 volts, at an input impedance of 150 megohms.

This high input impedance is necessary when measuring the high voltage of television power supplies.

The vacuum-tube ohmmeter has seven ranges and measures resistance from .5 ohm to 1000 megohms. The zero adjustment is fixed so that it does not need resetting when ranges are changed.

20. SERVICING WITH THE VEDOLYZER. To acquaint ourselves with the use of the Vedolyzer in Signal Tracing, let us examine the circuit shown in Fig. 11. We will use the Vedolyzer for servicing this receiver.

Connect a signal generator to the antenna and ground posts of the receiver through an artificial antenna. Set the signal generator to some frequency in the middle of the broadcast band and tune the receiver to this frequency. Increase its output to 0.01 volts or more and modulate the carrier from 50% to 75% at some audio frequency. The waveform of this audio frequency must be good if distortion is to be measured.

Press the "video" button on the probe selector and the "0.3V-0.9V" button on the function selector. Set the "circuit selector" at "RF3", advance the "vertical gain" all the way, and place the probe on the antenna post (position 1). The pattern on the screen should be that given in Fig. 11-1, when proper frequency and synchronization adjustments have been made. Synchronize the image on the signal frequency and not the carrier frequency.

When the correct image is obtained place the probe on the grid of the first RF tube (position 2). The image should show a definite increase in size, although the shape should be the same as for position 1 (See Fig. 11-2). If it does not, there is something wrong with the RF transformer. Make sure that the receiver is tuned to the input signal by rocking the tuning condenser back and forth. If the signal is OK there, proceed to the plate of this tube (position 3) with the universal probe. The image should be that in Fig. 11-3, if this stage is operating correctly. The image will probably be "off screen" by now due to the gain in the transformer and tube. If this is the case, press the 3V-9V button on the attenuator, or retard the vertical gain control. (The lat-

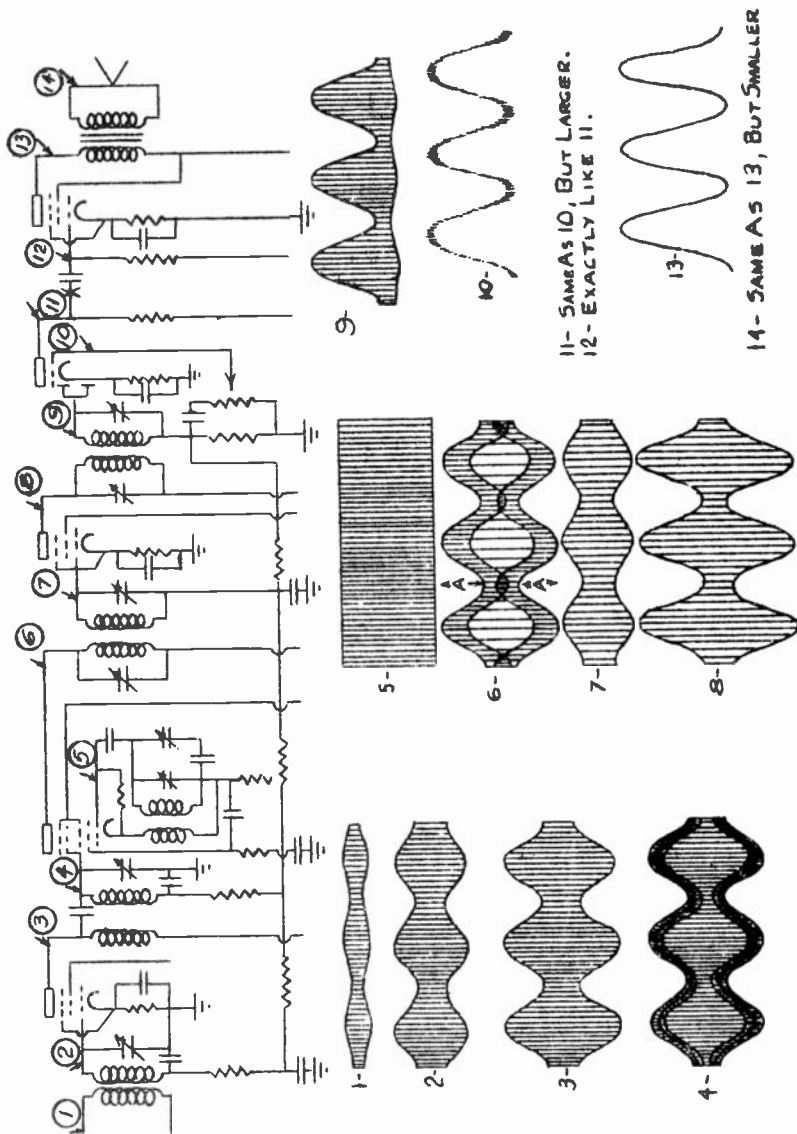

11- SAME AS 10, BUT LARGER.  
 12- EXACTLY LIKE 11.

14- SAME AS 13, BUT SMALLER

Fig. 11 Circuit used to explain the functions of the vedolyzer.

ter only if absolute gain is not desired.) Attenuate the signal from the generator if overload is present when the gain is reduced.

The image should keep in synchronization at all times if the gain is held within reason. That is, if the image is anything like the same size each time, it should remain stationary throughout these measurements.

The probe is next placed on the secondary side of the second RF transformer (position 4). The image will usually show a little gain here and at the same time, it will be mixed with the oscillator signal enough to change its appearance to Fig. 11-4.

Press the 30V-90V button and place the probe on the oscillator coil (position 5). The meter gives the voltage of the oscillator signal. The image is that of Fig. 11-5.

Now press the RF button on the probe selector and the range of the wavemeter that will probably contain the oscillator frequency. Measure this frequency with the wavemeter. Check to see if this is the correct oscillator frequency for the signal and IF of the receiver. (Oscillator Freq. - Signal Freq. = IF.)

Press the "Video" button and continue with the probe to the plate of the mixer tube (position 6). There are three signals here, two of which are modulated. They are RF, Oscillator, and IF in the group to interpret, but when the mixer is operating correctly, this image should look like Fig. 11-6. Rock the tuning condenser back and forth to insure this stage being in tune. The "valleys" marked "A" in Fig. 11-6 should be the deepest when correctly adjusted.

If this stage is not in tune it shows that the RF of the receiver is *misaligned*. Correct this by realigning the RF with the probe at position 6. (If the rest of the receiver is operating correctly, any of the positions above position 6 will do equally as well for this purpose.)

Now change the probe to position 7. The image should be that in Fig. 11-7. Notice that only the IF is now present. This is due to the filter action of the IF transformer. A noticeable gain should be experienced here although it will be difficult to compare the IF in Fig. 11-6 to that of Fig. 11-7.

The input to the receiver should now be cut down to give a medium sized image with the .3V-.9V button down ("Circuit selector" at either RF3 or RF9). Next place the probe on the plate of the IF amplifier (position 8). The image will show a very large gain here. If it goes "off screen", press button 3V-9V, or even 30V-90V. Position 9 should give Fig. 11-9 and position 10 that of Fig. 11-10. There is usually a loss in gain in both of these positions. The action of the detector is very clearly shown in Fig. 11-10. The IF that has not been filtered out is also easily seen.

At position 11, the audio image is very much larger and the RF in it is usually less. The gain control will, of course, have to be set full on to measure the gain in this tube. The signal at position 12 is almost the same as that at position 11, but when the probe is placed on the plate of this tube (position 13), a large gain will be noticed. (See Fig. 11-13) At position

14, the image will drop down again due to the step-down in the voltage in the output transformer.

21. THE AUDOLYZER. A third type of signal tracing instrument is the Audolyzer. This instrument is shown in picture form in Fig. 12, and schematic form in Fig. 13.

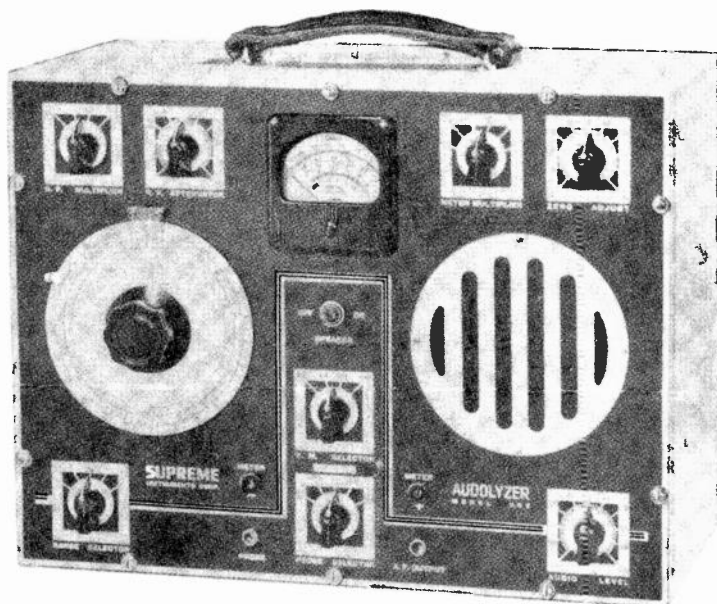

Fig. 12 Photograph of the Audolyzer.

Essentially, this instrument is composed of three sections namely:

1. The RF Amplifier
2. The Audio Amplifier
3. The Vacuum Tube Voltmeter

The RF Amplifier is composed of one untuned and one tuned RF stage terminating in a tuned diode detector. The input to the amplifier may be reached by two routes: First, through the probe and second, through the antenna lead.

The RF Amplifier is tuned over five bands with the range switch selecting the proper band. The frequencies covered by the different bands are:

- Band A - 95Kc to 250Kc
- Band B - 250Kc to 600Kc
- Band C - 600Kc to 1700Kc
- Band D - 1.7Mc to 5.0Mc
- Band E - 5.0Mc to 14.5Mc

These bands are identified on the tuning dial and also on the range selector.



The signal level reaching the detector is regulated by the RF multiplier and the RF attenuator controls located in the upper left-hand corner of the panel. It is possible to compare signal voltage values with the RF multiplier of 1000 to 1 and the RF attenuator of 100 to 1.

Either of two incorporated signal-indicating devices may be used with the RF amplifier. With the RF amplifier switch in the "on" position, the diode detector feeds an audio amplifier which drives a monitoring speaker. If you desire to use the audio amplifier as a separate unit, the vacuum tube voltmeter may be switched across the diode detector by turning the voltmeter selector to the RF position. The audio amplifier consists of a triode driving a pentode output stage which drives a five-inch dynamic speaker. The gain control, or "audio level", is located in the lower right-hand corner of the panel.

Primarily, the vacuum tube voltmeter reads DC volts, but it is so switched in the circuit that relative values of RF voltages and AF voltages may be read. In this manner, gain measurements may be made. When the instrument is first turned on the voltmeter reads off the left-hand scale. This is normal. The meter will take its center scale position as the instrument warms up.

The voltmeter may be used to read DC volts with the same probe which was used in connection with the RF amplifier and the audio amplifier. With the voltmeter selector in the external position and the probe selector in the voltmeter position, the test lead

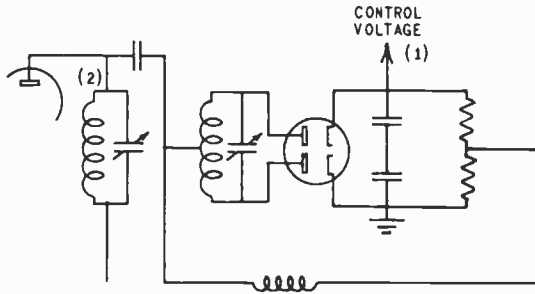

Fig. 14 A simple AFC discriminator circuit.

marked "probe" may be used to measure DC volts. If the probe is being used for some other function, DC volts may be read with any test lead thru the pin jacks marked "meter plus" and "meter minus". Regardless of which input is used, the input impedance is 15 megohms. In measuring voltages with the probe, a ground, or return, must be made to the radio chassis. If the voltage to be measured is above ground, the ground from the Audolyzer to the radio chassis must be removed and the return hooked to the proper point.

The meter has seven calibrated ranges which give full coverage of voltages normally encountered. The meter multiplier switch identifies the ranges as 1V-3V-10V-30V-100V-300V and 1000V.

Examining the circuit diagram shown in Fig. 13 we see that this instrument is fundamentally a tuned RF receiver consisting of one untuned and one tuned RF stage, a diode detector, an AF amplifier and a speaker. It is so arranged that by throwing the proper switches it acts as such a receiver. The gain of this receiver can be controlled either in the RF sections by the multiplier or attenuator, or in the AF section by the level control. As a receiver, this instrument is valuable in checking antennas for noise as well as for tracing interference.

With the instrument set up as a receiver, it is also used for checking the audio system of a receiver, or any audio amplifier. The procedure is as follows:

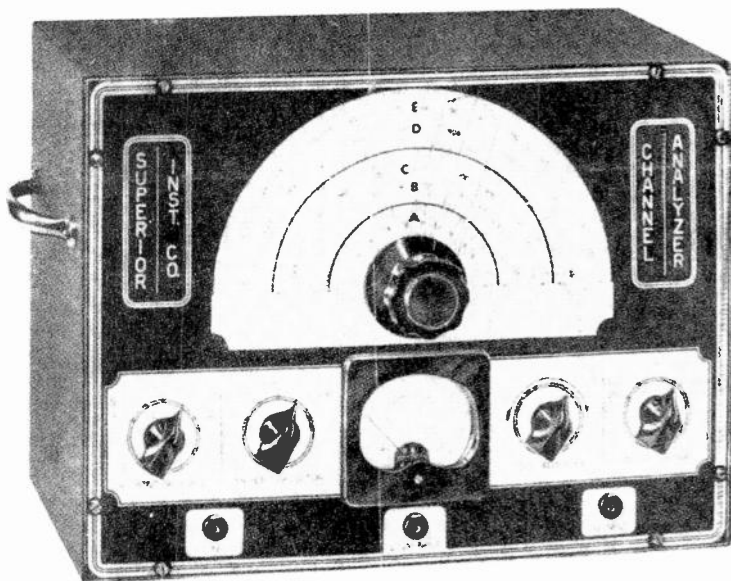

Fig. 15 Photograph of the Channel Analyzer.

With the Audolyzer set up as a receiver, an audio signal is available on the probe. Therefore, place test probe on the input of the first stage of the audio channel under test. If the signal does not go through the audio channel under test, proceed to the next stage. Since there is a 0.1 megohm resistor in the test probe, enough power for the last stage of audio amplification of an audio circuit is not available thru the probe. Accordingly, place a test lead in the A.F. output jack and use this signal to test the power stage and speaker of the receiver.





In the Audolyzer, in place of checking the signal level by means of a tuning eye, the signal level is checked by what is heard in the speaker. For gain-per-stage measurements, the electronic voltmeter is used. The electronic voltmeter is also used for voltage measurements.

The alignment of receivers using the Audolyzer varies from the usual practice somewhat. Most methods require the removal of the AVC voltage to allow the tuning of the circuits to their full sensitivity.

Inasmuch as the AVC voltage changes the input capacity of RF and IF amplifiers by varying their bias, the Audolyzer offers an excellent opportunity to do a better aligning job by tuning all circuits to their average operating conditions. First, this AVC voltage must be determined. Therefore, if the set is badly out of alignment, use the Audolyzer as an output meter and, with the local oscillator of the receiver dead, align the IF, using a test oscillator as a source of signal being fed into the receiver's mixer grid. Then move the test oscillator to the receiver's antenna, make the receiver oscillator operative and align the oscillator, RF and detector sections. Then tune in one or two of your favorite stations in this particular locality. With these signals passing through the receiver use the electronic voltmeter in the Audolyzer and measure the AVC voltage developed. This AVC voltage has changed the frequency of the RF and IF amplifiers. Accordingly, use a test oscillator and feed a modulated signal into the receiver, which will develop the same AVC voltages as your favorite stations mentioned above. Now realign the IF amplifiers for maximum gain as before. If the best of quality is to be had from the receiver, the next step is to check the bandpass of the IF's with a frequency modulator.

If the receiver has an AFC system, this should be made operative and aligned immediately after the IF's. A typical circuit is shown in Fig. 14.

With a test oscillator set the same as when aligning the IF's, place voltmeter probe on point (2), and align the primary of the discriminator transformer for maximum signal. Then place the voltmeter probe on position (1) and align the secondary for no signal indication on the voltmeter.

Next, align the RF, detector and oscillator sections of the receiver, using the Audolyzer as an output meter. This should be done at the frequencies specified by the receiver manufacturer.

22. CHANNEL ANALYZER. Fig. 15 shows a picture of the Channel Analyzer and Fig. 16 shows the circuit diagram of the same unit.

Fundamentally, this unit does not differ from the Audolyzer, except in the method of indication. Where the Audolyzer has a speaker as an indicating device, the Channel Analyzer uses a vacuum tube voltmeter. The tuned RF amplifier covers the frequency range from 100 kc to 18 mc in five bands.

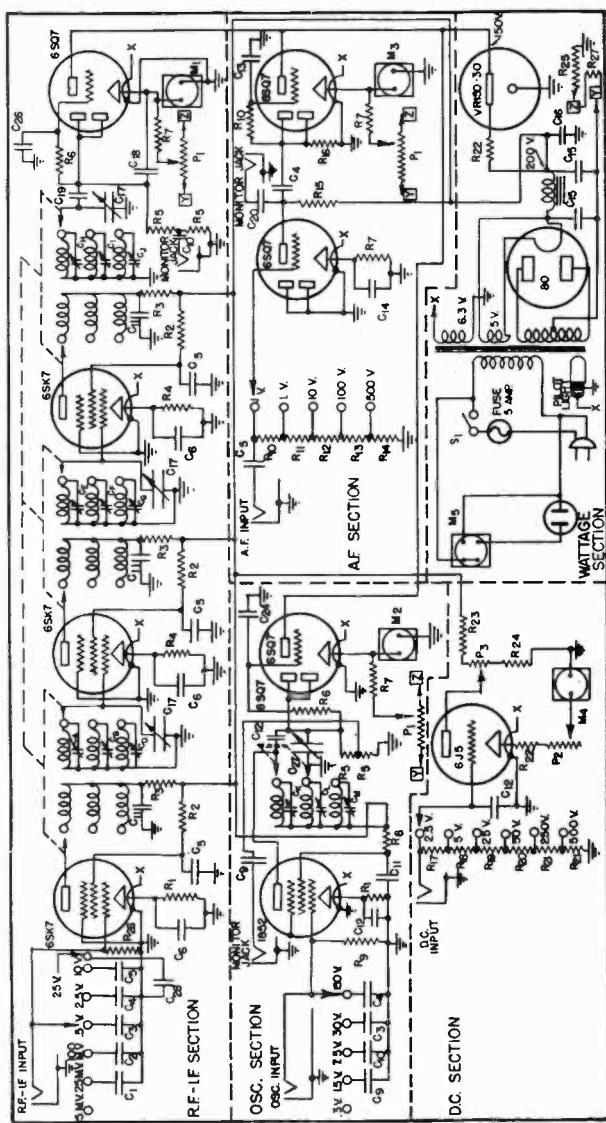

- R1 - 500 Ω 1/2 WATT
- R2 - 3 M Ω 1 WATT
- R3 - 75 K Ω 1/2 WATT
- R4 - 1500 Ω 1/2 WATT
- R5 - 300 Ω 1/2 WATT
- R6 - 5 M Ω 1/2 WATT
- R7 - 3 M Ω 1/2 WATT
- R8 - 75 M Ω 1/2 WATT
- R9 - 8 M Ω 1/2 WATT
- R10 - 5 M Ω 1/2 WATT
- R11 - 500 Ω 1/2 WATT
- R12 - 75 K Ω 1/2 WATT
- R13 - 8 K Ω 1/2 WATT
- R14 - 3 M Ω 1 WATT
- R15 - 1 M Ω 1/2 WATT
- R16 - 10 K Ω 1/2 WATT
- R17 - 150 Ω 1/2 WATT
- R18 - 2 M Ω 1/2 WATT
- R19 - 800 Ω 1/2 WATT
- R20 - 50 K Ω 1/2 WATT
- R21 - 75 K Ω 1/2 WATT
- R22 - 3 K Ω 1 WATT
- R23 - 50 K Ω 1/2 WATT
- R24 - 250 Ω 1/2 WATT
- R25 - DETERMINED IN PRODUCTION
- R26 - 300 Ω 1/2 WATT
- R27 - 150 Ω 1/2 WATT
- R28 - 2 M Ω 1/2 WATT
- R29 - 800 Ω 1/2 WATT
- R30 - 220 Ω 1/2 WATT
- R31 - 300 Ω 1/2 WATT
- R32 - 300 Ω 1/2 WATT
- R33 - 300 Ω 1/2 WATT
- R34 - 300 Ω 1/2 WATT
- R35 - 300 Ω 1/2 WATT
- R36 - 300 Ω 1/2 WATT
- R37 - 300 Ω 1/2 WATT
- R38 - 300 Ω 1/2 WATT
- R39 - 300 Ω 1/2 WATT
- R40 - 300 Ω 1/2 WATT
- R41 - 300 Ω 1/2 WATT
- R42 - 300 Ω 1/2 WATT
- R43 - 300 Ω 1/2 WATT
- R44 - 300 Ω 1/2 WATT
- R45 - 300 Ω 1/2 WATT
- R46 - 300 Ω 1/2 WATT
- R47 - 300 Ω 1/2 WATT
- R48 - 300 Ω 1/2 WATT
- R49 - 300 Ω 1/2 WATT
- R50 - 300 Ω 1/2 WATT
- R51 - 300 Ω 1/2 WATT
- R52 - 300 Ω 1/2 WATT
- R53 - 300 Ω 1/2 WATT
- R54 - 300 Ω 1/2 WATT
- R55 - 300 Ω 1/2 WATT
- R56 - 300 Ω 1/2 WATT
- R57 - 300 Ω 1/2 WATT
- R58 - 300 Ω 1/2 WATT
- R59 - 300 Ω 1/2 WATT
- R60 - 300 Ω 1/2 WATT
- R61 - 300 Ω 1/2 WATT
- R62 - 300 Ω 1/2 WATT
- R63 - 300 Ω 1/2 WATT
- R64 - 300 Ω 1/2 WATT
- R65 - 300 Ω 1/2 WATT
- R66 - 300 Ω 1/2 WATT
- R67 - 300 Ω 1/2 WATT
- R68 - 300 Ω 1/2 WATT
- R69 - 300 Ω 1/2 WATT
- R70 - 300 Ω 1/2 WATT
- R71 - 300 Ω 1/2 WATT
- R72 - 300 Ω 1/2 WATT
- R73 - 300 Ω 1/2 WATT
- R74 - 300 Ω 1/2 WATT
- R75 - 300 Ω 1/2 WATT
- R76 - 300 Ω 1/2 WATT
- R77 - 300 Ω 1/2 WATT
- R78 - 300 Ω 1/2 WATT
- R79 - 300 Ω 1/2 WATT
- R80 - 300 Ω 1/2 WATT
- R81 - 300 Ω 1/2 WATT
- R82 - 300 Ω 1/2 WATT
- R83 - 300 Ω 1/2 WATT
- R84 - 300 Ω 1/2 WATT
- R85 - 300 Ω 1/2 WATT
- R86 - 300 Ω 1/2 WATT
- R87 - 300 Ω 1/2 WATT
- R88 - 300 Ω 1/2 WATT
- R89 - 300 Ω 1/2 WATT
- R90 - 300 Ω 1/2 WATT
- R91 - 300 Ω 1/2 WATT
- R92 - 300 Ω 1/2 WATT
- R93 - 300 Ω 1/2 WATT
- R94 - 300 Ω 1/2 WATT
- R95 - 300 Ω 1/2 WATT
- R96 - 300 Ω 1/2 WATT
- R97 - 300 Ω 1/2 WATT
- R98 - 300 Ω 1/2 WATT
- R99 - 300 Ω 1/2 WATT
- R100 - 300 Ω 1/2 WATT
- C1 - 500 Ω 1/2 WATT
- C2 - 500 Ω 1/2 WATT
- C3 - 500 Ω 1/2 WATT
- C4 - 500 Ω 1/2 WATT
- C5 - 500 Ω 1/2 WATT
- C6 - 500 Ω 1/2 WATT
- C7 - 500 Ω 1/2 WATT
- C8 - 500 Ω 1/2 WATT
- C9 - 500 Ω 1/2 WATT
- C10 - 500 Ω 1/2 WATT
- C11 - 500 Ω 1/2 WATT
- C12 - 500 Ω 1/2 WATT
- C13 - 500 Ω 1/2 WATT
- C14 - 500 Ω 1/2 WATT
- C15 - 500 Ω 1/2 WATT
- C16 - 500 Ω 1/2 WATT
- C17 - 500 Ω 1/2 WATT
- C18 - 500 Ω 1/2 WATT
- C19 - 500 Ω 1/2 WATT
- C20 - 500 Ω 1/2 WATT
- C21 - 500 Ω 1/2 WATT
- C22 - 500 Ω 1/2 WATT
- C23 - 500 Ω 1/2 WATT
- C24 - 500 Ω 1/2 WATT
- C25 - 500 Ω 1/2 WATT
- C26 - 500 Ω 1/2 WATT
- C27 - 500 Ω 1/2 WATT
- C28 - 500 Ω 1/2 WATT
- C29 - 500 Ω 1/2 WATT
- C30 - 500 Ω 1/2 WATT
- C31 - 500 Ω 1/2 WATT
- C32 - 500 Ω 1/2 WATT
- C33 - 500 Ω 1/2 WATT
- C34 - 500 Ω 1/2 WATT
- C35 - 500 Ω 1/2 WATT
- C36 - 500 Ω 1/2 WATT
- C37 - 500 Ω 1/2 WATT
- C38 - 500 Ω 1/2 WATT
- C39 - 500 Ω 1/2 WATT
- C40 - 500 Ω 1/2 WATT
- C41 - 500 Ω 1/2 WATT
- C42 - 500 Ω 1/2 WATT
- C43 - 500 Ω 1/2 WATT
- C44 - 500 Ω 1/2 WATT
- C45 - 500 Ω 1/2 WATT
- C46 - 500 Ω 1/2 WATT
- C47 - 500 Ω 1/2 WATT
- C48 - 500 Ω 1/2 WATT
- C49 - 500 Ω 1/2 WATT
- C50 - 500 Ω 1/2 WATT
- C51 - 500 Ω 1/2 WATT
- C52 - 500 Ω 1/2 WATT
- C53 - 500 Ω 1/2 WATT
- C54 - 500 Ω 1/2 WATT
- C55 - 500 Ω 1/2 WATT
- C56 - 500 Ω 1/2 WATT
- C57 - 500 Ω 1/2 WATT
- C58 - 500 Ω 1/2 WATT
- C59 - 500 Ω 1/2 WATT
- C60 - 500 Ω 1/2 WATT
- C61 - 500 Ω 1/2 WATT
- C62 - 500 Ω 1/2 WATT
- C63 - 500 Ω 1/2 WATT
- C64 - 500 Ω 1/2 WATT
- C65 - 500 Ω 1/2 WATT
- C66 - 500 Ω 1/2 WATT
- C67 - 500 Ω 1/2 WATT
- C68 - 500 Ω 1/2 WATT
- C69 - 500 Ω 1/2 WATT
- C70 - 500 Ω 1/2 WATT
- C71 - 500 Ω 1/2 WATT
- C72 - 500 Ω 1/2 WATT
- C73 - 500 Ω 1/2 WATT
- C74 - 500 Ω 1/2 WATT
- C75 - 500 Ω 1/2 WATT
- C76 - 500 Ω 1/2 WATT
- C77 - 500 Ω 1/2 WATT
- C78 - 500 Ω 1/2 WATT
- C79 - 500 Ω 1/2 WATT
- C80 - 500 Ω 1/2 WATT
- C81 - 500 Ω 1/2 WATT
- C82 - 500 Ω 1/2 WATT
- C83 - 500 Ω 1/2 WATT
- C84 - 500 Ω 1/2 WATT
- C85 - 500 Ω 1/2 WATT
- C86 - 500 Ω 1/2 WATT
- C87 - 500 Ω 1/2 WATT
- C88 - 500 Ω 1/2 WATT
- C89 - 500 Ω 1/2 WATT
- C90 - 500 Ω 1/2 WATT
- C91 - 500 Ω 1/2 WATT
- C92 - 500 Ω 1/2 WATT
- C93 - 500 Ω 1/2 WATT
- C94 - 500 Ω 1/2 WATT
- C95 - 500 Ω 1/2 WATT
- C96 - 500 Ω 1/2 WATT
- C97 - 500 Ω 1/2 WATT
- C98 - 500 Ω 1/2 WATT
- C99 - 500 Ω 1/2 WATT
- C100 - 500 Ω 1/2 WATT
- P1 - 500 Ω 1/2 WATT
- P2 - 500 Ω 1/2 WATT
- P3 - 500 Ω 1/2 WATT
- M1 - OSC. VOLTMETER
- M2 - A.F. VOLTMETER
- M3 - D.C. VOLTMETER
- M4 - 5 M.F. WATTMETER
- M5 - 1 M.F. WATTMETER
- S1 - LINE SWITCH
- F1 - 5 AMP FUSE
- V1 - 250 V TRANSFORMER
- V2 - 6.3 V TRANSFORMER
- V3 - 80 V TRANSFORMER
- V4 - 500 V TRANSFORMER
- V5 - 500 V TRANSFORMER
- V6 - 500 V TRANSFORMER
- V7 - 500 V TRANSFORMER
- V8 - 500 V TRANSFORMER
- V9 - 500 V TRANSFORMER
- V10 - 500 V TRANSFORMER
- V11 - 500 V TRANSFORMER
- V12 - 500 V TRANSFORMER
- V13 - 500 V TRANSFORMER
- V14 - 500 V TRANSFORMER
- V15 - 500 V TRANSFORMER
- V16 - 500 V TRANSFORMER
- V17 - 500 V TRANSFORMER
- V18 - 500 V TRANSFORMER
- V19 - 500 V TRANSFORMER
- V20 - 500 V TRANSFORMER
- V21 - 500 V TRANSFORMER
- V22 - 500 V TRANSFORMER
- V23 - 500 V TRANSFORMER
- V24 - 500 V TRANSFORMER
- V25 - 500 V TRANSFORMER
- V26 - 500 V TRANSFORMER
- V27 - 500 V TRANSFORMER
- V28 - 500 V TRANSFORMER
- V29 - 500 V TRANSFORMER
- V30 - 500 V TRANSFORMER
- V31 - 500 V TRANSFORMER
- V32 - 500 V TRANSFORMER
- V33 - 500 V TRANSFORMER
- V34 - 500 V TRANSFORMER
- V35 - 500 V TRANSFORMER
- V36 - 500 V TRANSFORMER
- V37 - 500 V TRANSFORMER
- V38 - 500 V TRANSFORMER
- V39 - 500 V TRANSFORMER
- V40 - 500 V TRANSFORMER
- V41 - 500 V TRANSFORMER
- V42 - 500 V TRANSFORMER
- V43 - 500 V TRANSFORMER
- V44 - 500 V TRANSFORMER
- V45 - 500 V TRANSFORMER
- V46 - 500 V TRANSFORMER
- V47 - 500 V TRANSFORMER
- V48 - 500 V TRANSFORMER
- V49 - 500 V TRANSFORMER
- V50 - 500 V TRANSFORMER
- V51 - 500 V TRANSFORMER
- V52 - 500 V TRANSFORMER
- V53 - 500 V TRANSFORMER
- V54 - 500 V TRANSFORMER
- V55 - 500 V TRANSFORMER
- V56 - 500 V TRANSFORMER
- V57 - 500 V TRANSFORMER
- V58 - 500 V TRANSFORMER
- V59 - 500 V TRANSFORMER
- V60 - 500 V TRANSFORMER
- V61 - 500 V TRANSFORMER
- V62 - 500 V TRANSFORMER
- V63 - 500 V TRANSFORMER
- V64 - 500 V TRANSFORMER
- V65 - 500 V TRANSFORMER
- V66 - 500 V TRANSFORMER
- V67 - 500 V TRANSFORMER
- V68 - 500 V TRANSFORMER
- V69 - 500 V TRANSFORMER
- V70 - 500 V TRANSFORMER
- V71 - 500 V TRANSFORMER
- V72 - 500 V TRANSFORMER
- V73 - 500 V TRANSFORMER
- V74 - 500 V TRANSFORMER
- V75 - 500 V TRANSFORMER
- V76 - 500 V TRANSFORMER
- V77 - 500 V TRANSFORMER
- V78 - 500 V TRANSFORMER
- V79 - 500 V TRANSFORMER
- V80 - 500 V TRANSFORMER
- V81 - 500 V TRANSFORMER
- V82 - 500 V TRANSFORMER
- V83 - 500 V TRANSFORMER
- V84 - 500 V TRANSFORMER
- V85 - 500 V TRANSFORMER
- V86 - 500 V TRANSFORMER
- V87 - 500 V TRANSFORMER
- V88 - 500 V TRANSFORMER
- V89 - 500 V TRANSFORMER
- V90 - 500 V TRANSFORMER
- V91 - 500 V TRANSFORMER
- V92 - 500 V TRANSFORMER
- V93 - 500 V TRANSFORMER
- V94 - 500 V TRANSFORMER
- V95 - 500 V TRANSFORMER
- V96 - 500 V TRANSFORMER
- V97 - 500 V TRANSFORMER
- V98 - 500 V TRANSFORMER
- V99 - 500 V TRANSFORMER
- V100 - 500 V TRANSFORMER

Fig. 17 Schematic diagram of the Traceometer.

23. TRACEOMETER. The Traceometer, the most recent signal-tracing instrument to be placed on the market, is shown in schematic form in Fig. 17. This instrument is very nearly the same as the Chanalyst. However, one major difference may be noted. In place of using a tuning eye as the means of indication, the Traceometer uses meters in all circuits. Four channels are used; namely, the RF-IF, the Oscillator, the AF and the Wattage Channels.

Inasmuch as the instruments are operated exactly in the same manner, no further explanation of either the circuit or the use of this instrument is required at this time.



# Notes

*(These extra pages are provided for your use in taking special notes)*

# Notes

*(These extra pages are provided for your use in taking special notes)*

The text of this lesson was compiled and edited by the following members of the staff:

G. L. Taylor  
President and Chief Engineer  
Midland Television, Inc.

C. L. Foster  
Supt. of Instruction  
Midland Television, Inc.

C. V. Curtis  
Chief Instructor  
Midland Television, Inc.

R. E. Curtis  
Technical Drafting  
Midland Television, Inc.

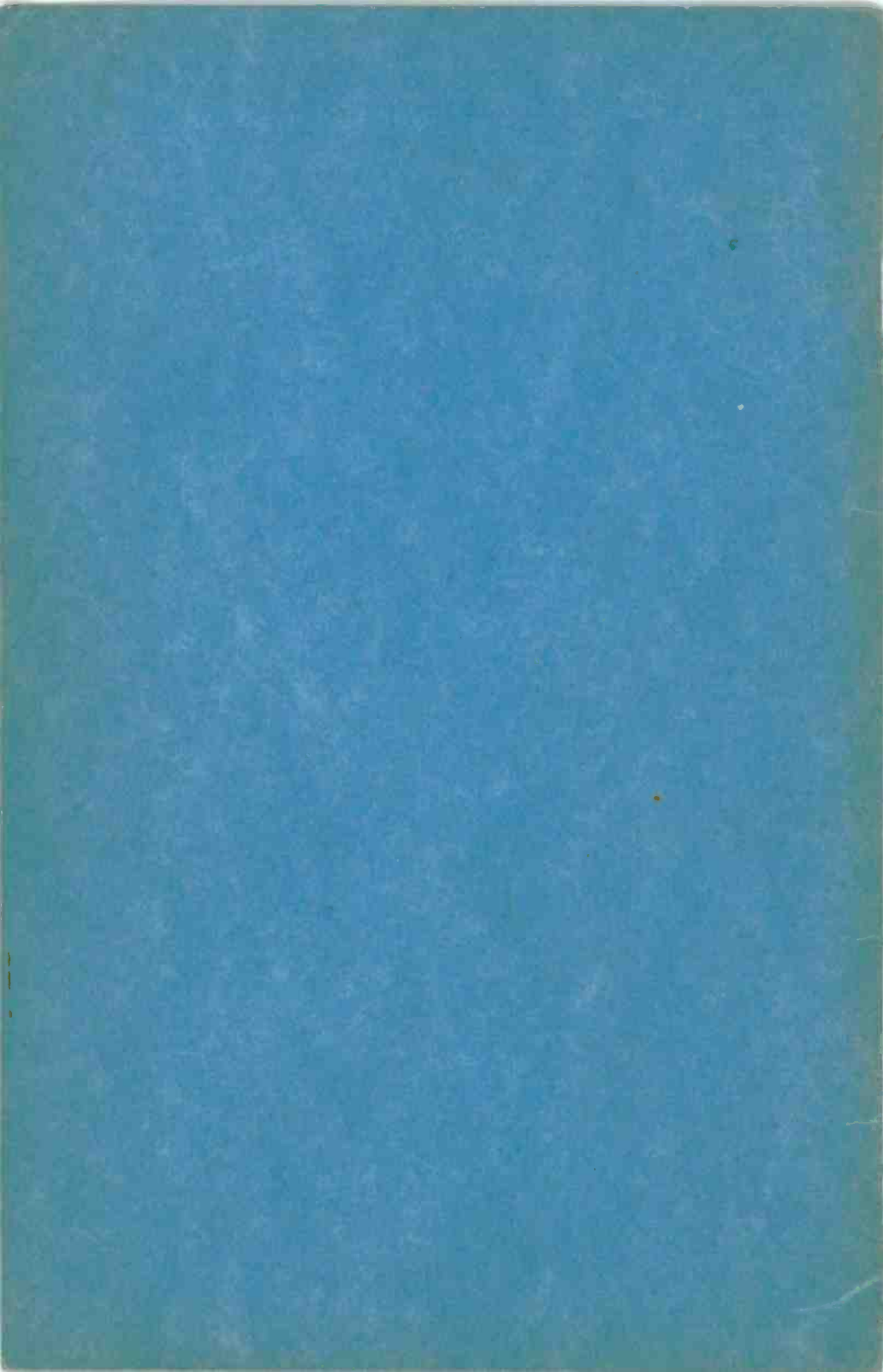





**MIDLAND RADIO  
AND TELEVISION  
SCHOOLS  
INC.**

**POWER & LIGHT BUILDING, KANSAS CITY, MISSOURI**

**UNIT  
NO.  
2**

**SERVICING OF  
SPECIAL RECEIVERS**

**LESSON  
NO.  
7**

# NEW MARKETS

.....bring greater fields of opportunity for you.

One of the chief reasons for the remarkable growth of the radio industry is that radio, in one form or another, has been and will continue to be used by many other industries. Radio is a very important factor in the commerce of the world and should not be considered as merely a medium of mere entertainment.

Here are just a few examples of other industries that have taken advantage of radio:

- ..... Air transportation is entirely dependent upon radio for communication.
- ..... The oil industry uses radio communications extensively.
- ..... The publishing of newspapers the world over is becoming more and more dependent upon radio.
- ..... Law enforcing agencies the world over use radio to capture criminals.
- ..... Radio stock market quotations play an important role in trading on stock exchanges throughout the world.
- ..... The broadcasting of farm produce quotations has enabled farmers to market their products when prices were highest.
- ..... Radio is of vital importance to ocean shipping and passenger travel.
- ..... The installation of radio receivers in automobiles has in itself become an industry. There are millions of receivers in cars throughout the world. And many millions more will be installed in the future.

This lesson deals with auto receivers along with other special receivers. It is an important lesson, for it covers another of the many applications of radio that can mean greater opportunity and more money to you:

Copyright 1941

By

Midland Radio & Television  
Schools, Inc.

PRINTED IN U.S.A.



KANSAS CITY, MO.

# Lesson Seven

## SERVICING of SPECIAL RECEIVERS



"In the first lessons of this unit you have received detailed instructions on the servicing of radio receivers in general. The basic methods of servicing receivers and the equipment to be used should be thor-

oughly familiar to you. There are many types of receivers, which for the most part are serviced in the same manner as discussed in our previous studies but differ in many details from the standard home type of receiver. We are speaking particularly of such receivers as the portable or battery-operated receiver, the Universal or AC-DC receiver, the Automobile receiver (which will be thoroughly discussed) and finally, Phonographs and Radio-Phonograph combinations."

"As stated above, the servicing of these receivers has much in common with previously studied methods. However, if we had endeavored to cover the variations in the special type receivers, we would have only caused confusion. Now with the basic servicing methods firmly in your grasp, you will be able to understand the variations encountered in special type receivers."

### PART ONE - BATTERY AND UNIVERSAL RECEIVERS

1. BATTERY RECEIVERS. In Fig. 1 is shown a typical schematic diagram of a battery-operated radio receiver. It consists of a combination First Detector and Oscillator, an I.F. amplifier, a combination Second Detector, Audio Frequency Amplifier and AVC stage and finally an output Audio Frequency Stage. Examining the circuit we see that basically it can be serviced and aligned by any method or combination of methods that have been previously studied. However, there is one very apparent difference between this receiver and the typical home receiver. It does not have the usual power transformer, rectifier, and filter circuits. In their place is a complement of an A battery and two B batteries which supply the entire power requirements of the receiver. Inasmuch as the power furnished by batteries is truly direct current, it is unnecessary to have extensive filter arrangements. As a result,

it is only necessary to measure the DC voltage of the batteries to complete the tests on the power supply system.

It may be well to mention at this point that through the endeavors of both tube manufacturers and battery manufacturers, the modern portable radio is fully dependable, serviceable, and yet light enough to be truly portable. Tube manufacturers have improved tube performance to a point where maximum efficiency is

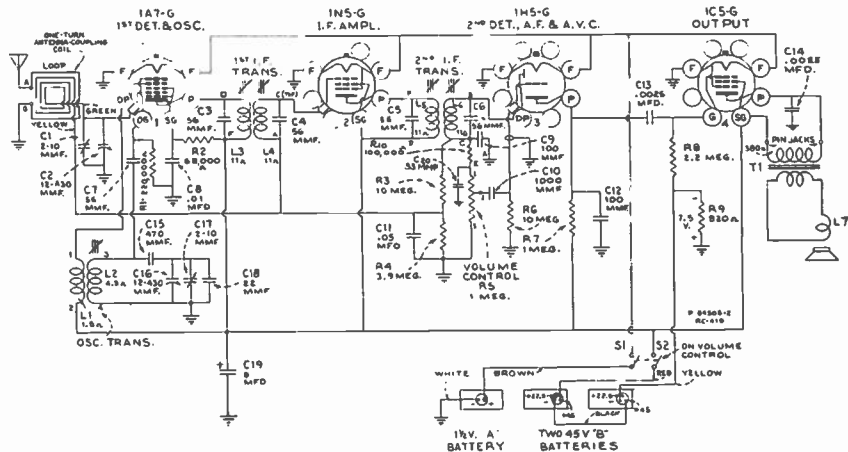
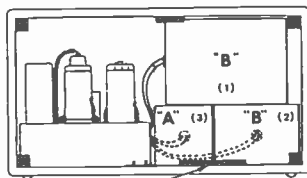
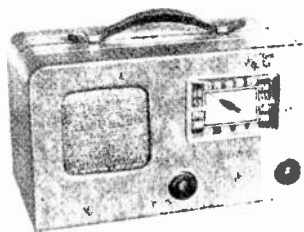

Fig. 1 Schematic diagram of typical battery-operated portable receiver. This has lengthened the life of the batteries appreciably. Battery manufacturers have increased the power of the batteries and at the same time made them lighter and smaller, both features desirable in portable sets. Now, as a result of these developments, battery life of 400 to 500 hours is not unusual.



REMOVE THIS BLOCK, PLUG IN CABLES AND PLACE BATTERIES IN CABINET AS SHOWN, IN THE ORDER INDICATED. REPLACE CLAMPING BLOCK.

(A)

(3)

Fig. 2 (A) Photograph of a portable receiver. (B) Rear view showing the placement of the batteries.

Another feature in the circuit of Fig. 1 is the single-turn antenna coupling coil. This is used where an external antenna is desired for extra sensitivity. Coupling to the receiver is obtained through this one turn which is coupled to the loop ordinarily used.

From our examination we have seen that the only variation from the usual home receiver is in the power supply, so let us determine what trouble might occur at that point. First, we know that the battery life is limited, so our first suspicion in encountering trouble is that it may be due to faulty batteries. Low sensitivity and distortion are usually traceable to old batteries; the low sensitivity being due to low voltages on the various tube elements, while distortion is due to the fact that

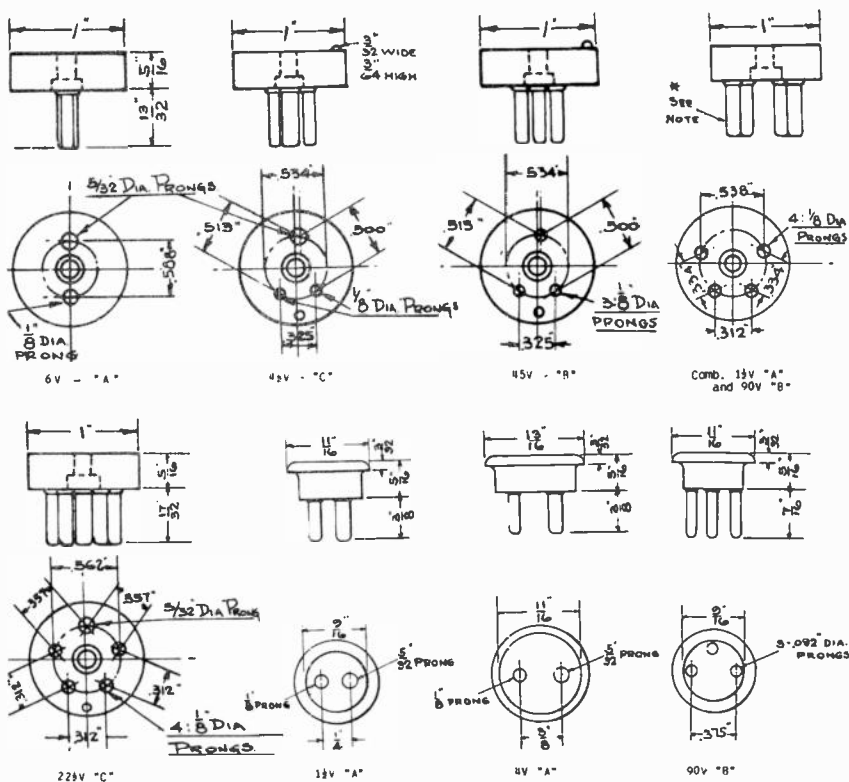

Fig. 3 illustrating different types of battery plugs and sockets. the voltage ratios between elements of the same tube are not correct, due to the low voltage of the supply batteries. Often, due to unforeseen circumstances, batteries become noisy even though they may be up to full voltage value. Such conditions can generally be detected either by inserting a new set of batteries or by checking each battery with a pair of headphones. As a rule, the resistance of the headphones will be sufficient load to show up the trouble in the batteries.

Fig. 2A shows a front view of a typical portable receiver. Fig. 2B shows a rear view with the rear cover removed and the batteries exposed. As a rule the receiving loop is attached to

the rear cover and can be removed and rotated for better reception.

In Fig. 3 is shown the several types of battery plugs now in common use. You will note that in every case it is impossible to place one type plug in a socket of another type. This prevents the danger of applying high voltage to filaments or heaters.

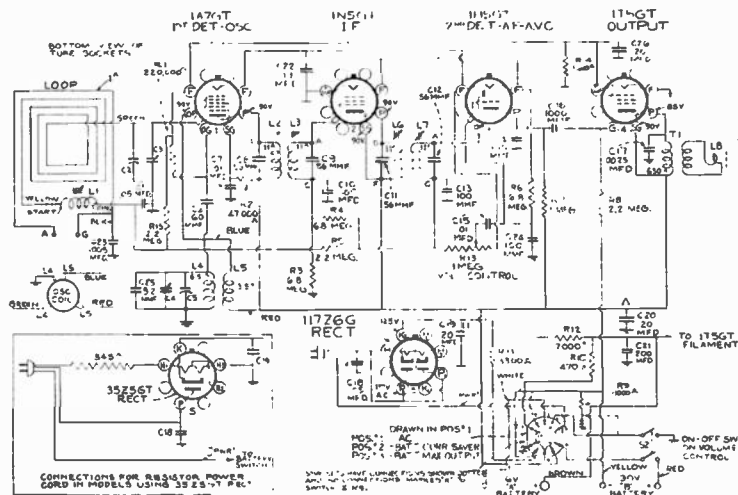

Fig. 4 A combination portable receiver which operates either on AC or batteries.

Fig. 4 is a schematic diagram reproduced mainly because of its uniqueness rather than for any service problem which it may present. This receiver is designed for both portable and home use, using either batteries or power from some AC source, depending upon the desires of the user. The switching circuit is so designed that it is impossible for any trouble to be encountered from both sources of power being turned on at the same time. Let us examine the circuit to see how this is accomplished.

The rotary switch in the lower right hand corner of the schematic has three positions as indicated. The second or middle position is a so-called "Battery Current Saver" position which is used on powerful local stations where the full sensitivity of the receiver is not required. The switch is shown in the AC position and if we trace the power lines through we will find that the cathodes of the rectifier are connected together and the plates of the rectifier are connected together forming a half-wave rectifier. One side of the power line is connected through the rectifier filament to ground. This same side of the power line is connected to the plates of the rectifier. The other side of the power line goes through the "power switch", through the on-off switch to ground. The B+ side of the circuit leads from the

cathodes of the rectifier through a resistance-capacity filter to the "power switch" and then to the plate circuits of the tubes. The plate circuits are completed since the filament circuit is connected to ground. In this case the tube filaments are supplied through a voltage dropping resistor R12 and a parallel resistor R10. You will note that the negative side of the A battery and the positive side of the B battery are open circuited due to the position of the power switch.



(A)

Battery Adaptor Cable which allows replacement of a 90 volt B battery pack with individual 45 volt B batteries. Fitted with sockets to take the plug from the receiver cable and two plugs to fit any standard 45 volt B batteries.



(B)

Battery Adaptor Cable which provides for replacement of battery packs on all sets using new AB packs with standard 45 volt B batteries and 1½ volt dry batteries.



(C)

Battery Adaptor Cable which has been designed to allow the replacement of battery packs in many battery operated sets with standard 45 volt B batteries and 2 volt wet A batteries. One end has a special 4-prong female receptacle to fit the 4-prong male plug on the receiver. The opposite end of the adaptor cable is fitted with two male plugs to fit any standard 45 volt B battery and two spade terminals to fit a wet 2 volt A battery.



(D)

Battery Adaptor Cable which has been designed to allow the replacement of the 1½ volt dry A battery with a 2 volt wet A battery. It is equipped with a 2-prong female receptacle at one end which fits the plug on the receiver cable. The opposite end is fitted with two spade type terminals to fit the posts on the storage battery. A resistor holder is placed on the A lead to allow for the different drain taken by sets with 4, 5, or 6 tubes.

Fig. 5 Illustrating different types of battery adaptor cables.

Now let us examine the circuit when the power switch is in position 2. (One step counter-clockwise from position shown). In this position, the AC power line is open and cannot be connected to ground. Also the cathodes of the rectifier are disconnected from the plate circuits. Now, however, we find that the negative side of the A battery is connected to ground, while B+ is connected to the plate circuits of the receiver; both of these circuits being controlled by the on-off switch. When the power switch is in this position you will note that a 1000 ohm resistor (R9) is placed between B- and ground. This has the effect of reducing the effective B voltage on the tubes and thus reducing the current drain from the B batteries. When the power switch is in the third position the only change is that this resistor (R9) is shorted out, thus increasing the sensitivity of the receiver at the expense of a shorter battery life.

One objection which has been raised to the portable receiver is the limited use to which it can be put. It is not practical



for any other purpose than for outings, picnics, and similar occasions, due to the limited life of the batteries. Recently, however, there has appeared on the market a series of adaptor cables or harnesses which can be used with portable receivers. With these cables it is possible to use the larger and consequently longer life batteries in conjunction with portable receivers. In this way the portable receiver can be used as a utility receiver in the bedroom, dining room, or kitchen, where the need for portability is not present. A series of these adaptors are shown in Fig. 5 together with sufficient information to outline their specific purposes.

At this point we might mention the many models of battery receivers designed for use in homes where electric service is not available. We refer particularly to table model receivers and console models in which batteries are used. From a servicing standpoint the only difference between portable battery receivers and home type receivers is the batteries used. The home type receiver uses a large heavy duty battery designed for long life. As a rule, dry A batteries are used in these receivers, although in some old receivers the storage battery is still employed.

**2. UNIVERSAL RECEIVERS.** Our discussion covering Universal receivers need not be extensive. As stated in preceding paragraphs in regard to battery receivers, the fundamental circuits of Universal receivers are the same as for the standard AC type receiver. Consequently, the servicing methods employed will again be the same regardless of the type set being repaired.

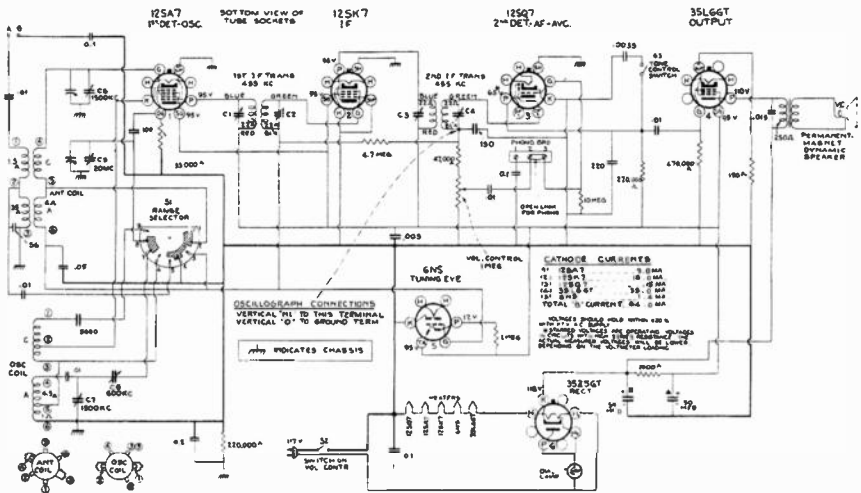

Fig. 6 Schematic diagram of a Universal Receiver.

As its name implies, a Universal receiver will operate equally well on either AC or DC power, provided that the line voltage is within the limits of the specifications of the receiver.



In Fig. 6 is shown a typical schematic diagram of a receiver designed to operate on either 110 volts AC or 110 volts DC. You will note that the R.F., I.F., and A.F. circuits are fundamental; that is, there are no changes from a standard AC receiver insofar as these circuits are concerned. In this case, as in the case of the battery receivers, the power supply system is basically different. A half wave rectifier is employed to obtain a DC current when AC is used. A resistance-capacity circuit forms the filter, with the screen voltage for the power tube being picked off at the second capacitor and plate voltage at the first capacitor. Plate voltage for the balance of the tubes is also taken at the second capacitor.

When DC is used, it is necessary that the positive side of the supply line be connected to the plate side of the rectifier tube. If the power plug should be reversed, the rectifier would not pass any current and the receiver would be inoperative.

One precaution should always be observed when servicing Universal receivers. The chassis should always be insulated from actual ground. This is necessary since with most receivers of this type, the chassis is at a different potential than either side of the power supply line. As one side of the power line is usually grounded, the receiver would again be inoperative if the chassis were also grounded.

## PART TWO - AUTOMOBILE RECEIVERS

3. INTRODUCTION. One of the largest single achievements in radio in the past few years has been the development in the auto radio field. This field, at first presenting certain technical difficulties in the way of power supply and interference, has now developed to the point where auto manufacturers supply radio receivers as standard equipment. This field has proved itself to be large enough for many service engineers to specialize in such activities as the sales, installation and servicing of auto receivers to the exclusion of all other work. In many other instances, Service Engineers have found a valuable source of income in the servicing of auto receivers in addition to their regular servicing business.

Due to the importance of this particular subject, we will devote a large part of this lesson to a discussion of all phases of auto receivers. A thorough knowledge of this subject is, of course, necessary in order to service, install or even sell an auto receiver.

4. POWER SUPPLY SYSTEMS. As in the previous special receivers studied the basic difference of the auto receiver from the home style receiver is in the power supply system. The first receivers built for use in automobiles used the car battery as a supply for the filament current, and B batteries for plate voltage. This system proved entirely inadequate, first because of the expense of the batteries themselves and the space required to house them, and second because of the interference picked up in the long battery leads required. Inasmuch as a battery-operated auto receiver is never seen any more, we will not discuss such a system.

There are then three types of power supply systems now found which will be discussed in detail. They are:

1. The AC generator; either directly connected to the engine or operated by a 6 volt DC motor.
2. The DC generator or genemotor driven by an integral 6 volt motor.
3. The Vibrator power supply, which may either be of the synchronous or non-synchronous type.

5. ALTERNATING CURRENT GENERATORS. One form of power supply for the auto radio is the AC generator. It may be connected directly to the engine or may be driven by a DC motor which obtains its power from the car battery. When driven from the engine of the car, either through a belt or directly connected, the frequency generated will vary according to the speed of the engine. In spite of this variation in frequency, satisfactory operation of most radios can be obtained when the frequency is above 50 cycles. The design of the unit can be made such that the frequency will be above this minimum. You will note that the minimum frequency is critical, while the maximum frequency is not, even up to several hundred cycles.

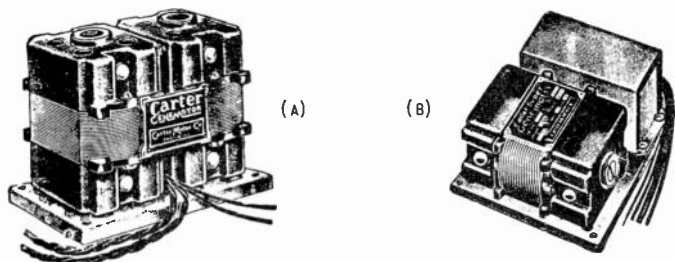

Fig. 7 (A) Photograph of a gen-e-motor. (B) Photograph of a motor-generator power supply.

This type of power supply allows the use, in many cases, of standard home receivers in the automobile, and so is especially suited for use in trailers. In addition, many other items such as fans, toasters, etc. can be operated from the same generator.

There are two major objections to this type of power supply. First, as in the case of the battery supply system, the question of shielding from interference is a major problem. Second, it is necessary to supply an auxiliary gas engine to obtain power when the car motor is not in use. This system, for these reasons, is seldom used except for advertising trucks, trailers, etc. In the latter case, the generator is often used to supply voltage for neon advertising signs, motion picture equipment, etc.

6. DC GENERATOR UNITS. In the DC Generator type of power supply system sufficient DC voltage is generated to supply the plates of the tubes, allowing the use of higher power tubes, especially in the output stages.

In general there are two types of DC generators used although they may appear under many different trade names. The only difference between the two units is in the method used to furnish the field excitation. One unit, generally referred to as a magmotor, uses a permanent magnet to supply the field excitation for the generator. The other type unit, usually called a generator, uses an electromagnet for field excitation.

The magmotor has the advantage of taking less current from the car A battery, but also is subject to loss of magnetization due to the vibration of the car. Due to the latter objection the generator type unit is more universally used. Fig. 7 shows two of the generator type B supply units. The one at A is a dual unit used to furnish an average voltage and current output, whereas the one at B includes a complete filter unit. Both the magmotor and generator type units are available for battery voltages of 6, 12, 24, or 32, volts with output ratings from 150 volts at 50 milliamperes to 1000 volts at 150 milliamperes. The higher output units are designed for use in portable or mobile public address equipment as well as for mobile transmitters.

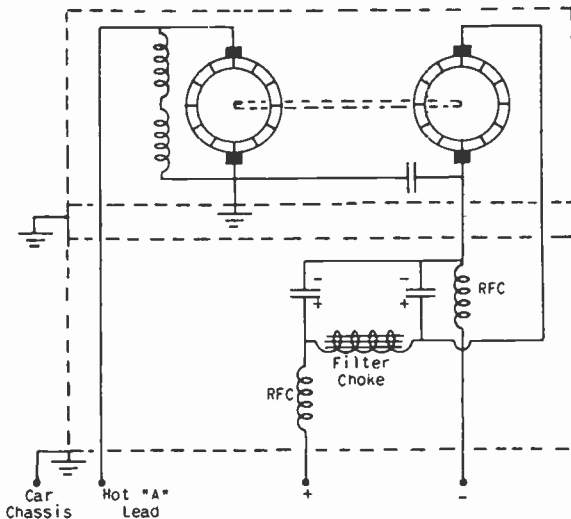

Fig. 8 Diagram of a motor-generator unit with complete filter system.

Usually some ripple is present in the DC current due to the contact between the brushes and commutator on the DC generator. To keep this ripple from reaching the radio receiver and causing interference it is necessary to use some type of filter. Inasmuch as this ripple is of comparatively high frequency and as a rule only a small percentage of the total output, an elaborate filter system is not necessary. Consequently, a small choke and two bypass capacitors normally constitute the filter. In cases where the

generator field is excited from the car battery it is also necessary to use a filter in the A supply leads. This is needed only if the car battery also furnishes the power for the tube filaments in the receiver. In this case, R.F. chokes and by-pass capacitors must be used to prevent interference from reaching the receiver through either the A or B leads. In Fig. 8 there is shown a diagram of a generator type B supply unit with a filter in the B leads.

Generator type B power supply units have been found to give far more satisfactory service with radio receivers and mobile P.A. systems than the more popular vibrator type B supply. Most of these units are small in size. Many are so compact that they may be held in the palm of the hand. About the only attention this B supply requires is an occasional cleaning of the commutator and replacement of the brushes. When cleaning the commutator, be sure to use sandpaper. Never use emery paper as it contains a metallic material which is liable to become wedged between the commutator segments and cause a short circuit. Some types also require an occasional oiling. In spite of these advantages, the high initial cost has prohibited the use of the motor-generator as a common source of B voltage in auto receivers.

7. VIBRATOR TYPE POWER SUPPLY. In recent years the vibrator power supply has practically superseded all other types of high voltage supplies for automobile receivers. This universal application of the vibrator is due to its comparatively high efficiency, small size, and low cost.

There are two general types of vibrators in use today; the non-synchronous, which requires a rectifier tube; and the synchronous, which acts as a mechanical rectifier.

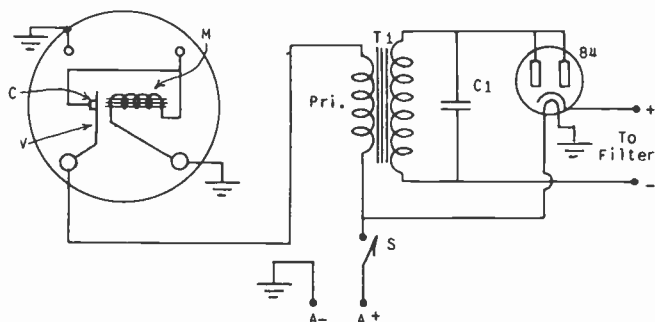

Fig. 9 Diagram of half-wave vibrator interruptor circuit.

In Unit 1 you learned that a power transformer was used to step up the line voltage to a higher voltage as required. In this case, however, the voltage was AC and could be fed to the primary of a transformer, and the required high voltage could be taken from the secondary. However, in the automobile receiver, our only source of power is from the car battery which is a DC source. In

order to produce higher voltages, we must convert this DC into a pulsating DC or AC before feeding it into the primary of the power transformer. This is done by means of the vibrator.

A simple vibrator circuit is shown in Fig. 9. In this circuit the vibrator converts the pure DC into pulsating DC which is then fed to the primary of the transformer T1. As soon as the switch is closed, a DC current will flow through the coil M, through contact point C, which is held closed by the vibrating reed and through the primary of the transformer. However, as soon as current passes through the coil M (which is an electromagnet) it becomes magnetized and pulls the vibrating reed toward it. This

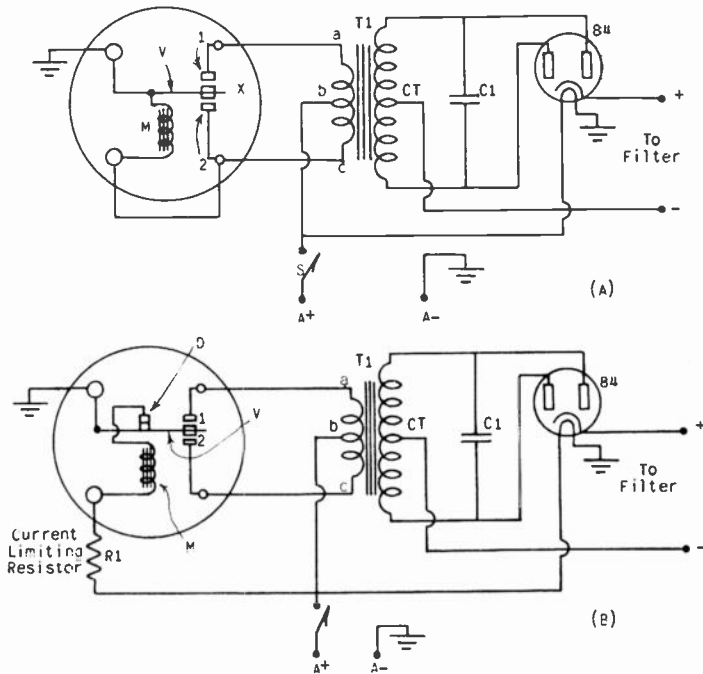

Fig. 10 (A) Modern full-wave non-synchronous vibrator circuit. (B) Diagram of non-synchronous full-wave vibrator circuit.

immediately stops the current flow by opening the circuit. As soon as the current stops flowing, M becomes demagnetized, allowing the vibrating reed to return to its original position. The vibrating reed is pulled back to its original position by its own tension. When C makes contact with the contact point on the vibrating reed, current again flows and the above process repeats itself. It is easy to see that this will cause a pulsating direct current to flow through the primary of the transformer T1, which will, by mutual induction, cause an AC voltage to be induced in the secondary. As the transformer is a step-up type, the AC voltage induced in the

secondary will be a high voltage. This voltage is then rectified by the rectifier tube. The filter system is similar to that used in any standard AC-operated receiver. The purpose of C1 will be given later in this lesson. Although this vibrator system may still be employed in a few sets, it has been almost entirely replaced by the full wave type vibrator unit. A full wave, non-synchronous (tube) vibrator power supply is shown in Fig. 10A. An explanation of the operation is as follows.

As the switch S is closed, a current will flow from the negative side of the battery through the chassis to the vibrator arm V, through the electromagnet M to point (C) through the primary of the transformer T1 from C to B and back to the battery. The current flowing through M immediately magnetizes it and the vibrating reed is pulled toward M. The amount of current flowing through the primary of the transformer T1 at this time is so small that it may be disregarded. As the arm is pulled toward the magnet, it makes contact with point 2. This permits a current to flow through the primary of the transformer T1, which by mutual induction causes a voltage to be produced in the secondary of T1. A current will now flow from the center tap of the secondary winding, through the load and return to the cathode; from the cathode to the right hand plate of the rectifier tube and back to the top of the power transformer.

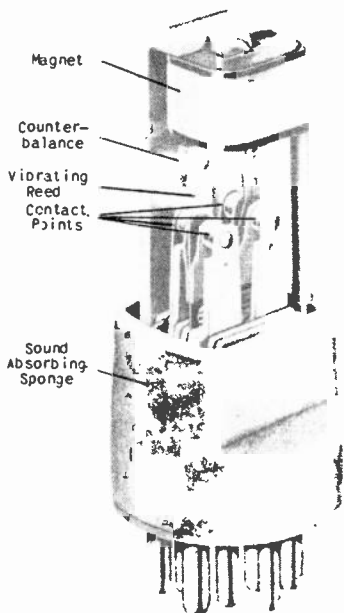

Fig. 11 Picture of modern full-wave synchronous vibrator, showing the placement of the various parts. Courtesy, P. R. Mallory & Co.

At the same time the making of the contact between the vibrating reed and contact 2, shorts M which causes the magnet to become demagnetized. Due to the tension of the vibrating reed, as soon as M is demagnetized the reed will fly back and strike contact

point 1. A weight is often placed at point X on the vibrating reed for the purpose of giving more velocity to the arm. The weight or counter-balance is often made of a magnetic material so it may also be used as the attraction point for the magnet M. A modern vibrator using the counter-balance in this manner is illustrated in Fig. 11.

As the contact point on the vibrating arm strikes contact 1, there will be a flow of current from the chassis through the arm to point 1, from point 1 to point A, through the transformer to point B and return to the positive side of the battery. This causes a voltage to be induced in the secondary and a current to flow from the center tap of the high voltage winding through the load to the cathode of the rectifier tube, from the cathode of the tube to the left hand plate and from there back to the bottom of the transformer. The magnet which is now magnetized draws the arm back to point 2 and the action repeats itself.

There are many other types of non-synchronous vibrators, but their basic principles are the same as for the two types just described. Some types use a different method of interrupting the current through the magnet M. The usual difference is that a separate contact is placed on the vibrator arm so that the magnet current is not drawn through the transformer primary. Such a circuit is shown in Fig. 10B. There are a great many different types of vibrators in use having different circuits and various ratings. For this reason it is always wise to use an *exact duplicate* when replacing a defective vibrator, unless specified otherwise by the manufacturer.

From the explanation given in the preceding paragraphs, it appears that this system is ideal for converting DC into AC. However, there are several factors which must be considered to make these circuits function properly. The foremost consideration is the surges created when the vibrating reed makes and breaks contact with points 1 and 2. Some method of limiting these surges must be introduced to prevent the possible burning out of the power transformer, the breakdown of filter condensers and also the pitting and burning of the vibrator contacts themselves. One method would be to place a capacitor across the primary of the transformer. This would require such a large capacitor that the price would be prohibitive. However, a low capacity, high voltage unit across the secondary of the transformer will have the same effect and be a great deal more economical. This buffer condenser, as it is called, must be a high voltage unit to withstand the surges which may be many times the RMS value of the induced secondary AC voltage. Often resistors are placed in series with the buffer condenser to limit the current flow through it.

There are three factors which determine the capacity of the buffer condenser to be used. They are:

- (1) The type of vibrator used.
- (2) The power transformer used.
- (3) The load on the power supply.

The difference between synchronous and non-synchronous vibrators, the spacing of the contact points, and the physical construction of the vibrator itself, will all change the strength and effect of the voltage surges.

Due to the distributed capacity in the transformer windings, all transformers resonate at some frequency. If the frequency of the surges approaches the resonant peak of the transformer, the surge peaks will be much greater.

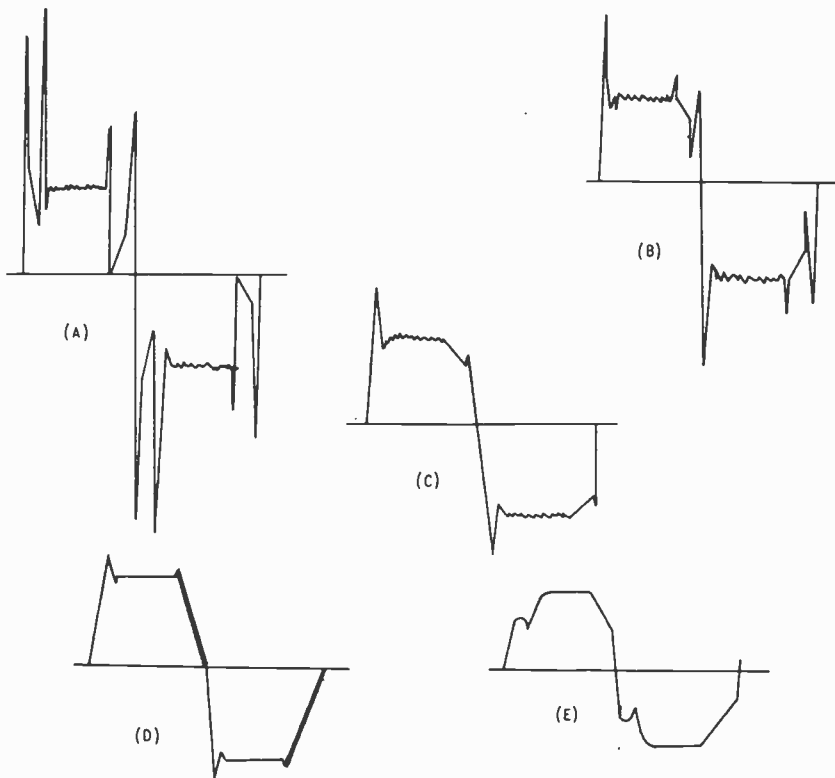

Fig. 12 (A) waveform of voltage across secondary when no buffer condenser is used. (B) when a .02 mfd. condenser is used. (C) when a .02 mfd. buffer condenser and a 20,000 ohm load is used. (D) when a .02 mfd. condenser and 10,000 ohm load is used. (E) when a .1 mfd. buffer condenser and 10,000 ohm load is used.

As the load on the power supply is increased, the peak values of the surges will be cut down.

From the above, it can be seen that the size of the buffer condensers will vary in different sets. Therefore, it is important that when replacing a buffer condenser, you use one with the same value of capacity and with at least the same voltage rating.

As a further explanation of the action of the buffer condenser let us look at Fig. 12. At (A) we see the waveform of the



voltage across the secondary of the power transformer when no buffer condenser is used; (B) illustrates the waveform when a .02 mfd. capacitor is added across the secondary of the power transformer. Both (A) and (B) are taken assuming there is no load on the power supply. Fig. 12C is the waveform when a load of 20,000 ohms is placed on the unit under test, while 12D illustrates the effect of a 10,000 ohm load. In Fig. 12E, the .02 mfd. capacitor was replaced with a .1 mfd. capacitor. You will notice that in each step the waveform has been improved. The sharp peaks have been eliminated, although the waveform is not sinusoidal.

From the above explanation we might be led to assume that the largest capacity of buffer condenser consistent with economy would be most advantageous to use. This is not the case as can be seen by examining Fig. 13.

DC VOLTAGE OF BATTERY	CURRENT DRAWN FROM THE BATTERY	CAPACITY OF BUFFER	DC VOLTAGE OUTPUT OF POWER SUPPLY	VALUE OF LOAD RESISTOR	WAVE FORM AS VIEWED ON OSCILLOSCOPE
6	.85 Amperes	None	410 Volts $\Delta$	None	Very Bad
6	1.075 Amperes	.02 Mfd.	400 Volts $\Delta$	None	Fair
6	3.05 Amperes	.1 Mfd.	310 Volts	None	Good
6	1.4 Amperes	None	265 Volts $\Delta$	20,000 Ohms	Very Bad
6	1.7 Amperes	.02 Mfd.	270 Volts	20,000 Ohms	Fair
6	3.4 Amperes	.1 Mfd.	265 Volts	20,000 Ohms	Good
6	1.8 Amperes	None	235 Volts $\Delta$	10,000 Ohms	Very Bad
6	2.1 Amperes	.02 Mfd.	245 Volts	10,000 Ohms	Good
6	3.6 Amperes	.1 Mfd.	235 Volts	10,000 Ohms	Beginning To Show Waste Of Sec. Voltage
6	2.1 Amperes	None	195 Volts	5,000 Ohms	Bad
6	2.6 Amperes	.02 Mfd.	193 Volts	5,000 Ohms	Good
6	3.8 Amperes	.1 Mfd.	182 Volts	5,000 Ohms	Shows Waste Of Sec. Voltage

$\Delta$  Indicates that the output was varying slightly.

Fig. 13 Illustrating the effect of changing the size of the buffer condenser and the load.

This chart shows the current consumed from the battery under varying loads and with different size buffer condensers. It will be noted that as the capacity of the buffer condenser is increased, the current consumed from the A battery is also increased. However, there is no increase in the voltage output of the power supply; in fact, there is a slight decrease. As it is important to keep the current drain from the battery as low as possible, consistent with maximum voltage output, it is easy to see why a buffer condenser larger than necessary is not used. On the other hand, the larger the capacity of the buffer condenser, the better the waveform produced. Thus a capacity must be

selected that will satisfactorily remove the voltage peaks and at the same time not waste the battery power.

There remains one other important item to consider before the vibrator power supply will operate satisfactorily. This is the elimination of "vibrator hash" or the R.F. interference developed by the vibrator. This "vibrator hash" is caused by transient voltage surges at an R.F. rate and cannot be eliminated by the buffer condenser.

At present three methods of eliminating this interference are used:

1. Complete and careful shielding.
2. Careful grounding of all components.
3. Proper R.F. filtering of all leads to and from the vibrator power supply.

You will find that all vibrators are enclosed in metal cases or shields. This is done to minimize the audible noise and also to act as a shield. As a rule this shield is connected to one of the vibrator prongs. In this case the contact on the vibrator socket corresponding to this prong must be carefully grounded to the chassis. In addition to this ground, the vibrator is usually clamped in place by some device to insure that it will not work out of its socket causing a poor contact to ground. Rubber pads are sometimes used both inside and outside of the vibrator case to reduce audible noise.

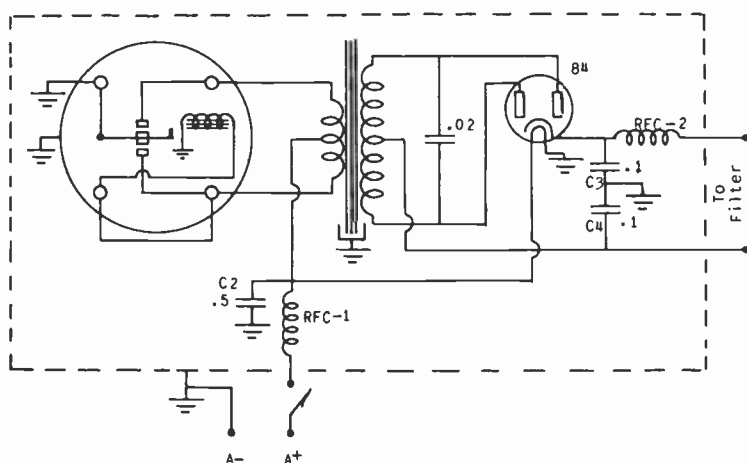

Fig. 14 Diagram of a full-wave non-synchronous vibrator unit complete with rectifier tube and R.F. filter.

It is not sufficient to shield only the vibrator; the receiver must be carefully shielded. Special springs are used between the covers and the chassis to make positive contact between these parts.

There remains one easy path for R.F. to get to the set and "hash" the signal. This is by way of the leads to and from the

power supply. Fig. 14 is the same as Fig. 10A except that the proper steps have been taken to prevent these transient R.F. surges from getting to the receiver by way of the A and B leads. RFC-1 and C2 prevent R.F. from entering the set through the A

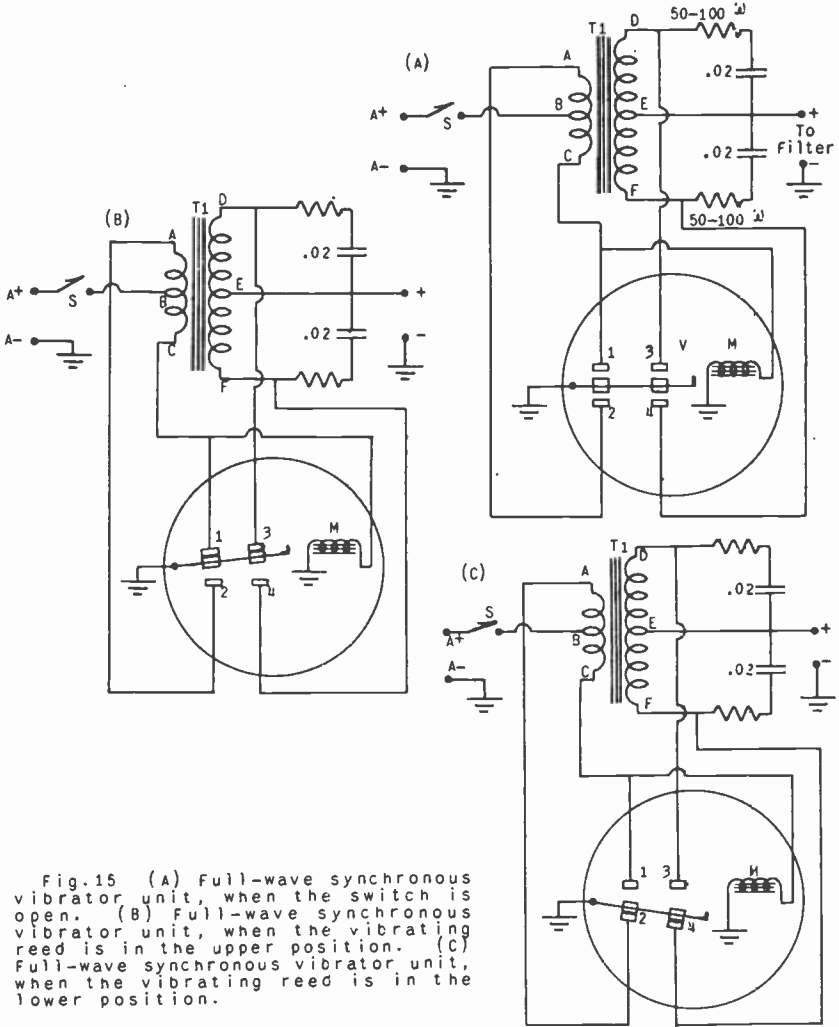

Fig. 15 (A) Full-wave synchronous vibrator unit, when the switch is open. (B) Full-wave synchronous vibrator unit, when the vibrating reed is in the upper position. (C) Full-wave synchronous vibrator unit, when the vibrating reed is in the lower position.

lead. Likewise, RFC-2 and the .1 mfd. condenser C3 prevent the R.F. from getting to the set by way of the B+ lead. C4 is not necessary when B- is grounded. If B- is not grounded, this condenser should have a capacity of at least .1 mfd. A resistor having a value of above 100 ohms is often used across the primary of the transformer to cut down hash.

In our discussion to this point we have covered only that type of vibrator which requires a tube for rectification. This vibrator is known as the non-synchronous type. There is another kind of vibrator called the synchronous type. In this unit, no rectifier tube is used and the vibrator not only converts the low DC voltage to AC, but also takes the high voltage AC from the power transformer secondary and rectifies it.

A vibrator of this type is shown at A, B, and C in Fig. 15. Its operation is as follows: When switch S is closed, a small current will flow from the negative pole of the battery to the chassis, through the chassis to the vibrator magnet M, and through M to point C on the primary of the transformer. From this point the current will flow through the primary of the transformer from C to B, then return to the positive side of the battery. Fig. 15A shows this circuit. The current flowing through M makes M a temporary electromagnet. The current flowing through the primary of T1 at this time is so weak that the voltage induced in the secondary by this current may be disregarded. M, upon becoming magnetized, attracts the vibrating reed toward it, causing the reed to make contact with points 1 and 3. These points are so arranged that they both make contact with the reed at the same time. This produces a current flow from the negative terminal of the battery, through the chassis, through the reed to contact 1, from contact 1 to point C and through the primary of the transformer from C to B. A voltage is induced in the secondary by mutual induction. This causes a current to flow from point D to point 3 on the vibrator, through the reed to the chassis, through the load and filter, then return to point E on the secondary of the power transformer T1. The path is shown at B in Fig. 15.

When the reed comes in contact with point 1, another action takes place. Coil M is shorted out and thus loses its magnetism. The tension of the vibrating reed now throws it back and causes it to strike contact points 2 and 4. This is shown at C in Fig. 15. As a result of the reed striking points 2 and 4, a current will flow from the negative side of the battery to the chassis, through the chassis to the reed. From here it will flow through the reed to point 2, from point 2 to point A, through the primary of the transformer from A to B, then return to the positive side of the battery. By mutual induction, a voltage is induced in the secondary of the transformer. As a result of this induced voltage, a current will flow from F to point 4 on the vibrator, through the reed to the chassis, through the load and filter and return to point E. At the same time, M again becomes magnetized. M pulls the vibrating reed back over to points 1 and 3 and the above action repeats itself. The buffer condensers consist of two .02 mfd. condensers in series, with a small resistor in series with each. A single buffer condenser having a higher voltage rating may be used in place of the two, if it is so desired.

With the synchronous type vibrator, if the polarity of the input is reversed, the polarity of the DC output of the vibrator is also reversed. The set naturally will not work in this condition. If allowed to continue, the DC current would soon ruin

the electrolytic filter condensers; therefore, some means must be provided to reverse the polarity of the input to the vibrator. In some cases, this may be done by merely removing the vibrator, turning it 180° and returning it to its socket. A vibrator of this type is shown in Fig. 16. Part A of Fig. 16 shows a wiring diagram of a special 7-prong socket. The seventh prong is in the

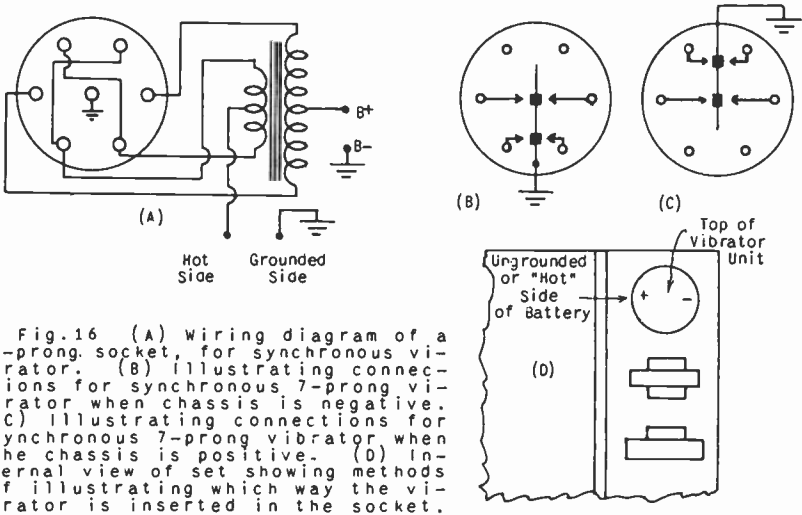

Fig. 16 (A) wiring diagram of a 7-prong socket, for synchronous vibrator. (B) illustrating connections for synchronous 7-prong vibrator when chassis is negative. (C) illustrating connections for synchronous 7-prong vibrator when the chassis is positive. (D) Internal view of set showing methods of illustrating which way the vibrator is inserted in the socket.

center of the base and is grounded. Part B in Fig. 16 shows the position of the vibrator when the negative side of the storage battery is grounded to the frame of the car; part C shows the proper connection when the positive side of the battery is grounded; while part D shows how the position of the vibrator is indicated inside the set. This is a very simple, convenient, and economical means of changing the polarity of the vibrator. This method is incorporated in most of the modern sets which use a synchronous vibrator. In many of the older sets, however, it was necessary to change the direction of current flow to the vibrator circuit by reversing the connecting leads.

In recent years the use of the cathode ray oscilloscope in the testing of vibrators has gained in popularity. It is practically impossible to give specific waveforms to be used for comparison purposes in servicing work. However, in the following paragraphs we will attempt to show the effect of some basic vibrator defects upon the waveform of typical vibrators.

In general, symmetrical waveform is desirable and any variation from symmetry is an indication of trouble of some type. Excessive sparking at the contacts is productive of noise and shows up on the oscillograph as jagged off-shoots and streams. It is desirable to correlate the waveform as observed with the cathode ray oscillograph and the output voltage as measured across the load with a DC voltmeter.

In Fig. 17A we see a typical waveform as taken across one half of the primary of the power transformer of a full wave circuit. Fig. 17B shows the waveform as taken across one half of the secondary of the power transformer in the same circuit. These waveforms are typical of satisfactory operation. You will note that the waveform is symmetrical in both cases and that there is a noticeable lack of distortion and unexplainable variations.

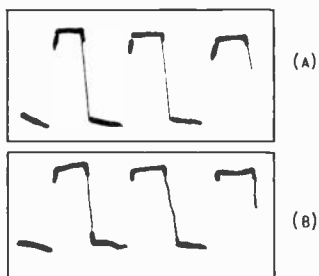

Fig. 17 (A) Voltage wave across half of primary of power transformer. (B) Voltage wave across half of secondary of power transformer.

In Fig. 18 we see typical waveforms resulting from various defects in the vibrator. Fig. 18A shows the resulting waveform across the primary of the power transformer when one contact of a full wave vibrator is open circuited or does not make contact with the vibrator arm. Fig. 18E shows the waveform of the secondary of

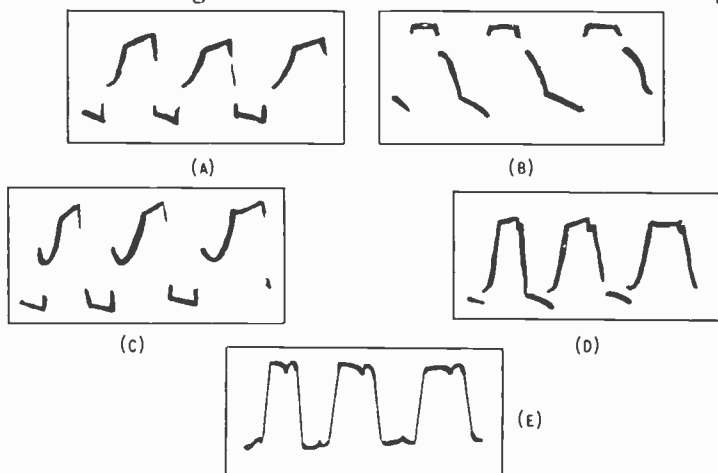
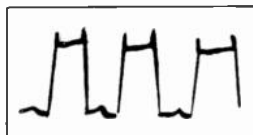

Fig. 18 (A) voltage wave across primary when one of the vibrator contacts is inoperative. (B) Waveform across secondary under the same conditions. (C) Waveform across primary when one contact is inoperative and the other has too large a spacing. (D) waveform across primary with both contacts operating but spacing is too great. (E) Waveform across secondary under the same conditions. the power transformer under identical conditions. Fig. 18C shows the resultant waveform across the primary when the above conditions exist, and in addition the spacing between the active contact and the vibrator arm is too great. Now let us assume that

both contacts are closing but the spacings for both are too great. The resulting waveform is illustrated in Fig. 18D and 18E. Fig. 18D is taken across one half of the primary of the power transformer and 18E across the corresponding half of the secondary.

In Fig. 19 is shown the resulting waveform when contacts are pitted and burnt. You will note the peaks due to arcing at the contacts.

Fig. 19 The voltage waveform which results when the contacts are pitted and burned.



It is again pointed out that the illustrated waveforms given above should not be used as a basis for comparison with waves obtained by the service engineer with his own equipment. Due to the many types of vibrators and vibrator circuits, it is next to impossible to furnish complete data in the space available. More and more manufacturers are learning the value of the cathode ray oscilloscope in this work and are furnishing the necessary waveform illustrations in their service notes.

8. AUTOMOBILE ANTENNAS. One of the most important components of an auto radio installation is the antenna. Even though the radio set used is the most expensive and best performing obtainable, if a poor antenna is used it will often cause poorer reception than a cheap set using the best antenna. The best auto antenna, however, is very inefficient compared to an outdoor aerial usually used with a home broadcast receiver.

Auto receiver antennas operate on a different principle than the aeriels studied in Unit 1. There we learned that the potential developed across the antenna coil depends upon the effective height of the antenna. In an auto radio installation, however, the receiver operates upon the voltage developed between the antenna and the body of the car. Under normal circumstances the distance between the car antenna and actual ground will have little effect upon the voltage induced in the receiver antenna coil.

It is simpler, then to match the antenna coil to the receiver than in the case of home receivers, since the design engineer has sufficient information available on the different capacities for different antennas. The following table gives the average capacity between antenna and the car body including the lead-in.

AERIAL	CAPACITY IN MMFDS.	RELATIVE PICKUP
Hinge Whip	40-60	55-70
Hinge Extension	40-60	55-95
Cowl Extension	50-70	55-110
Four-Foot Roof	85-100	55-110
Built-in Roof	150-250	85-200
Under-Car	200-400	75-110

In the above table the difference in capacities is due mainly to the lead-in. As you will learn later in this lesson, all parts of the radio set, including the aerial lead-in, must be

carefully shielded to prevent the noise generated by the ignition system of the car from interfering with the broadcast signal. Although ordinary shielded wire may be used for this purpose, the results will be unsatisfactory, especially if the lead-in wire is long. This is due to the fact that the high capacity formed between the lead-in wire and the shield attenuates the signal. In other words, there is nothing to be gained by having good aerial pickup unless the signal is fed from the aerial to the radio through an efficient lead-in. The efficiency of the lead-in depends upon the following.

1. The length of the lead-in wire.
2. The kind and amount of insulation.
3. The distributed capacity.
4. The type and size of the wire.
5. The type of shielding.

Naturally, the length of the lead-in wire will determine the amount of loss of the lead-in. The amount of insulation will determine the distance between the lead-in wire and the shielding; that is, increasing the amount of insulation between the lead-in wire and the shielding will decrease the capacity. The lead-in wires are invariably of large outside diameter so as to keep the wire itself as far away from the shielding as possible and thus reduce capacity losses. The insulation in most cases is treated to make it moisture-proof so there will be no leakage losses between the aerial lead-in wire and the grounded shielding. It was learned in Unit 1 that due to "skin effect" there will be losses developed in the wire unless proper precautions are taken. The best method of reducing the skin effect is to use several strands of small insulated wire instead of a single large wire. Therefore, the type and size of wire used will be a determining factor in the losses developed by the lead-in wire. The purpose of the shielding is to keep all stray magnetic and electrostatic fields away from the lead-in wire. At the same time, it should be flexible in order to provide ease of installation. The lead-in plays an important part in the proper installation of an auto radio, and

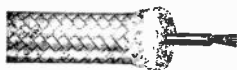

Fig. 20 Picture of modern low capacity lead-in cable.

care must be taken in its selection and use. In fact, the lead-in wire accounts for a large part of the total cost of the better grades of auto aeri-als. Fig. 20 is a picture of a modern low-capacity lead-in cable. You will note the stranded wire, covered with rubber insulation to prevent voltage breakdown. Over this is a thick layer of insulation to space the outer shield from the conductor.

In making an auto radio installation, the matching of the antenna coil of the receiver to the antenna is an important consideration. In low-capacity installation (below 150 mmfds.) it



is usual practice to connect the antenna directly to the receiver. However, in installations using insulated trunk cover or insulated door antennas, where the capacity is high (250 to 2000 mmfds.) it is necessary to use a capacitor in series with the antenna lead-in. Some manufacturers furnish small tubular capacitors which fit a fuse retainer, for this purpose. Fig. 21 shows two typical retainers.



Fig. 21 (A) Picture of a modern fuse retainer. (B) Picture of an antenna receptacle.

Some manufacturers use an antenna coupling condenser to provide variable adjustment of the capacity in the antenna coil. It is a trimmer condenser inserted in series with the antenna coil as illustrated in Fig. 22. In an installation using this system, the trimmer should be adjusted for maximum volume with the receiver tuned to a station at the low frequency end of the dial.

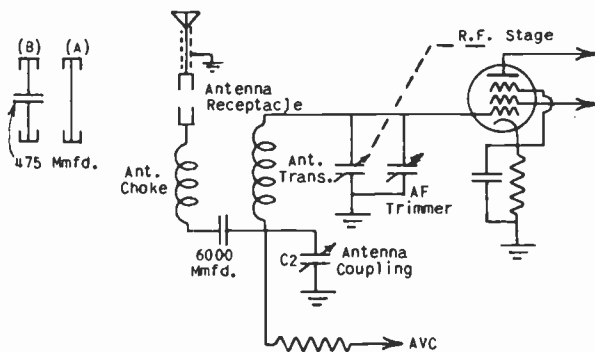

Fig. 22 Method of varying the antenna coupling capacity.

Another method of matching the aerial to the antenna coil of a car radio is illustrated in Fig. 23. It consists of a single pole, double throw switch, so connected that when the switch is in the "roadway" position, only the lower half of the antenna coil is utilized. Thus, the input impedance is low. This will correctly match a high capacity aerial, such as a running board aerial. When the switch is in the "skyway" position, all of the input inductance or antenna coil is in the circuit, resulting in a high input impedance. This will properly match the new low-capacity cowl type aerials. Proper matching is obtained because a high-capacity aerial offers a fairly low terminating impedance,

while the reverse is true with a low-capacity aerial. The switch is accessible from the side of the set. The shaft has a slot in it and may be thrown from one position to the other by inserting a screwdriver and turning in the direction desired. If you are not sure as to which is the proper setting, tune in a station on the low-frequency end of the dial and set the switch in the position that will give maximum volume.

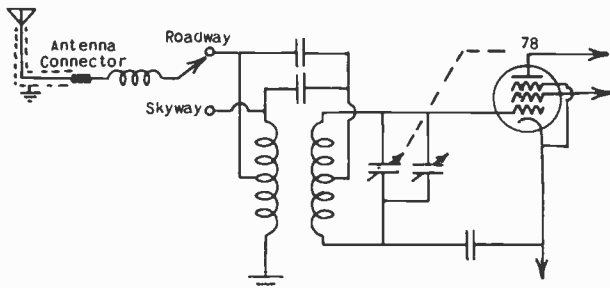

Fig. 23 Antenna input circuit illustrating one method of matching aerial to set.

There are various other ways of matching the aerial to the input of the set; however, they are all based on the fact that car radio antennas may be divided into two general classes; high-capacity and low-capacity. To match the antenna coil of the set, one of two general methods must be used; either insert a series condenser of the proper value to offset the high-capacity of the antenna, or vary the input inductance to match correctly the impedance of the antenna at the broadcast frequency.

9. ANTENNA INSTALLATION. Now that you have a general idea of the problems confronting the auto radio design engineer, let us select a few of the most commonly used types of aerials and learn how to install them so they will operate most efficiently. The type of aerial selected will depend largely upon the construction of the top of the car and the preference of the car owner.

There are, at the present time, about six different types of auto top construction. These are as follows: (1) Fabric top; (2) Metal bow top; (3) Folding top; (4) Poultry top; (5) Slat top; (6) Turret top.

If the car in which the aerial is to be installed has a fabric, metal bow, poultry, or slat top, practically any type of aerial may be used. If the car has a folding top, it is usually desirable to employ some type of aerial other than the top aerial. Although a top aerial may be installed that will not interfere in any way with the folding of the top, it is unlikely that the set will operate satisfactorily when the top is folded back. Also, a top aerial should not be installed in turret top cars because the capacity between the top and the aerial is too high to give satisfactory performance on the average auto set. When the inside

of the car is so constructed that it would be very difficult to take off the upholstery cloth, a top aerial should not be installed.

Due to the difficulty of installation and the other difficulties mentioned, a wire screen aerial is very seldom used in modern installations, even though this type is still the most efficient. When properly installed, many of the modern aeri-als, such as the dual running board type and the telescoping cowl aerial, compare favorably with the screen type aerial. Some cars without turret tops are equipped with a built-in aerial, which is invariably of the screen type.

The leads of these factory installed aeri-als are brought down either the right or left hand corner posts and may be found by inspecting the bottom of each corner post. If no lead is found after very carefully searching the base of each corner post (about the level of the dash) it will be necessary to take down the header bar and install a lead. Before doing this, be absolutely sure of two things; first, that the car does have a built-in aerial, and second that the lead has not become wedged in an obscure portion of the corner post.

If the aerial already has the lead-in attached, the problem of aerial installation is limited to merely increasing the length of the lead-in. In some cars, the lead-in has a cable connector on the end of it; however, in most cases the shielded lead-in is brought to the lower edge of the dash and cut off. If the lead-in has a shielded cable connector on the end of it, it is only necessary to put the other end of a similar connector on the extension and run the extension to the set. Use low-capacity cable for this purpose. When soldering the lead-in wire to the plug, be sure that the wire is so fastened that the spring will operate. Also, be sure that the outside shielding of the lead-in is thoroughly soldered to the outside shield of the plug, and that the lead-in wire does not short through the shield. After completing the connection, bond the lead-in shield to the chassis of the car by soldering a strip of three-quarter inch tinned copper braid to the connector and solder the other end of the braid to the chassis of the car, carefully cleaning and tinning the chassis of the car at the point of the bond.

If the lead-in wire does not terminate in a cable connector, it will be necessary to splice the other cable to the end of it. Push back the shielding as far as possible and strip off the outer insulation for about an inch and a quarter. Now strip off all the inner insulation for about an inch. Do this on both the lead-in and the extension wires. Next, splice and solder the two wires together and cover with regular friction tape. Now, wind rubber tape over this connection until the point of contact is as large in diameter as the rest of the insulated cable. After this, pull the shielding over the tape from one end and cover it with solder. Now, place the shielding from the other end over this. Heat the entire connection and solder. This makes a well shielded and permanent connection. Having done this, bond the joints to the chassis of the car, following the same procedure as outlined pre-

viously for bonding the cable connection to the frame of the car with a wire braid.

Many of the lead-in wires supplied with a built-in aerial are not shielded. If this is the case, either replace the lead-in with a low-capacity cable or shield the wire as far as possible with some form of shielding. If you do the latter, it will be best to use shielding loom to shield the wire up the corner post. Be sure that you securely ground the lower end of the shielding to the frame of the car. Use regular low-capacity cable for the extension.

At the present time, there are many types of aerials on the market. Since installation instructions are included with practically all of these aerials, only general instructions will be given concerning the various types. When selecting and installing an aerial, the following things should be kept in mind: First, the aerial should either be out of sight or should be attractive. Second, if the aerial is to extend very far above the top of the car, it should be collapsible and flexible. Third, the aerial should be durable. Fourth, it should be easy to service. Fifth, it should have good pickup. Sixth, neither the aerial proper nor its lead-in should interfere with the functioning of any part of the car. Seventh, the lead-in should be as short as possible. Eighth, the lead-in should be of the shielded, low-capacity type. Ninth, the aerial should be as far away from the engine and all electrical equipment as possible, consistent with a short lead-in. Tenth, the capacity of the aerial to the chassis of the car should be as low as possible.

Let us now consider the various types of antennas from the standpoint of advantages and disadvantages of each type. In this discussion we will also mention some of the points which must be closely watched when making antenna installations.

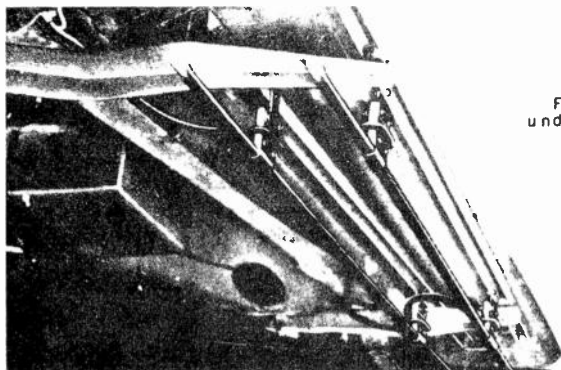

Fig.24 Photograph of under-car aerial.

Insofar as the signal pickup is concerned, the dual under-car aerial is very efficient. However, this type of aerial has three disadvantages, one of which is its high capacity. The high capacity is due partially to the long lead-in that is necessary. An-

other disadvantage is that due to its location, it quickly becomes caked with mud, sometimes causing a high resistance leakage to the chassis of the car and resulting in poor signal pickup. Being close to the road, it is apt to be damaged or the lead-in wire broken if the car is driven over rough roads. The third disadvantage of this type of auto aerial is that the noise reduction problem, particularly wheel static, is greatly increased. More information concerning wheel static will be given later in this lesson. Fig. 24 shows an under-car auto aerial, illustrating main points to bond and shield. In spite of these disadvantages, the under-car aerial has experienced extreme popularity. It is about as efficient as any auto aerial, with the exception of the wire screen type.

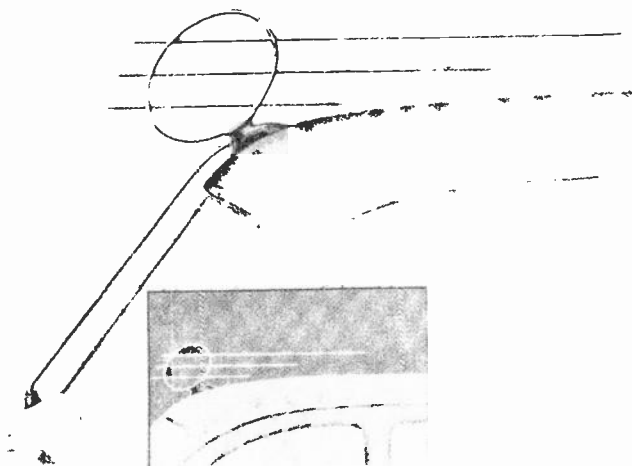

Fig. 25 A popular type of roof aerial.

Recently the manufacturers of some automobiles have so constructed their running boards that they may be insulated from the chassis of the car and used as an aerial. The efficiency of this aerial is slightly greater than that of the under-car aerial previously described. To convert the running board into an aerial, it is only necessary to remove the iron washer supports and replace them with insulator washers. After doing this, wire the running boards together and fasten the shielded lead-in cable to the front end of the running board which will provide the shortest lead to the set. This is usually the one on the driver's side. When installing this type of aerial, be sure that the shield on the lead-in wire is grounded to the frame of the car and not to the running board. If the shield is connected to the running board, the aerial would be shorted to the chassis of the car. Even when installing the conventional type under-car aerial,

be sure that the shield is grounded to the frame of the car rather than to the running board. If on the running board, it would not short out the aerial, but would be apt to provide a poor ground connection, resulting in excessive noise pickup. However, be sure that it is grounded as close to the end of the lead as possible.

To obtain satisfactory results with an under-car aerial, be sure to use the dual type. In other words, if you are installing the insulated running board type, be sure to utilize both running boards. When installing the type that mounts under the running board, be sure that you mount the strips or rods on both sides, one pair under each running board. If the under-car aerial should consist of a single plate, mount one of these plates under each running board.

Another aerial which has wide popularity is the outside roof type. An aerial of this type is shown in Fig. 25. When properly installed, most of these aerials are quite attractive and have fairly good pickup. The main disadvantage is the relatively high capacity which exists between the chassis of the car and the aerial. Compared to the running board aerial, this aerial has slightly less pickup, but it is practically free from static and requires much less servicing and attention.

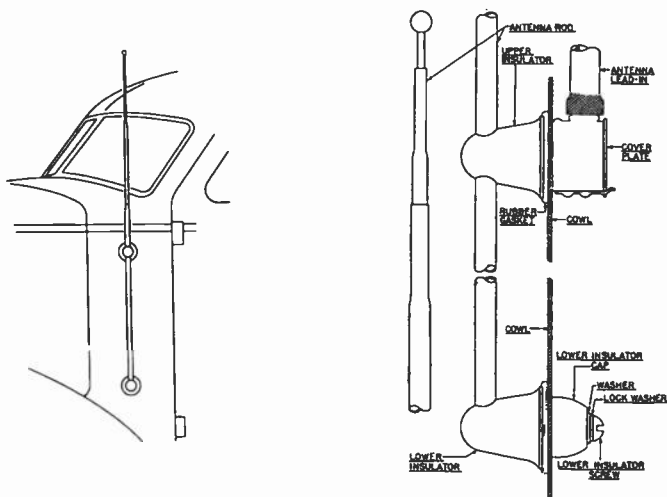

Fig. 26 A telescoping cowl type aerial.

There are four general classes of top aerials: (1) The type that fastens on the roof with suction cups and cement; the lead-in coming in through the header over the top of the windshield. (2) The type that fastens on the roof with suction cups; the lead-in is brought down in front of the windshield and enters the car below the windshield just in back of the cowl vent opening.

(3) The type which fastens to the top with self-tapping screws inserted through insulating blocks; the lead-in is concealed, coming through the header above the windshield. (4) The type mounted with self-tapping screws; the lead-in coming down in front of the windshield and entering back of the cowl vent opening. A special rubber cement is supplied to prevent leaks through the holes in the roof. The small insert in Fig. 25 illustrates an installation using the concealed type lead-in.

Another popular aerial is the telescoping cowl aerial. It is one of the best and likewise one of the most popular types of aerials at the present time. Fig. 26 illustrates such an aerial. Connection is made to the lead-in by means of a long screw which also acts as one of the two supports. The lead-in fastens to the aerial on the inside of the car in a special junction box. This junction box is completely shielded, even to a cover plate which snaps in place. As the aerial is on the cowl and normally mounted on the same side of the car as the set, the lead-in wire may be made very short. The complete shielding and very short lead-in produce a high signal-to-noise ratio.

Many other types of car aerials are available and undoubtedly more will be introduced each year. When selecting one of these for installation, its features should be weighed on a comparative basis. If one takes the following points into consideration, he should expect very satisfactory results.

1. Durability.
2. Ease of Installation.
3. Obtain as great a signal-to-noise ratio as possible.
4. Ease of Servicing.
5. If in sight, should be attractive.
6. Type of set used.

10. RECEIVER INSTALLATION. In the early days of automobile receivers, an installation was dreaded by the service engineers. There were many bulky units to mount and the placement of these units was always a major problem. However, when the vibrator power supply was introduced, the installation problems were greatly simplified. Modern auto receivers are compact, attractive, and a great many devices have been utilized which aid the service engineer in the installation.

There are two types of auto receivers, classified according to the location of the speaker. Single unit receivers incorporate the loudspeaker, receiver, and vibrator power supply in one case. The dual unit is made up of one unit containing the receiver and vibrator power supply while the speaker is housed in a separate case. In this type of unit, the speaker may be mounted either on the bulkhead or on the header bar.

As the installation of the various sets will vary considerably and since the instructions are included with every set, we will not attempt to give the details for any particular set. If the following general rules are carefully heeded, the service engineer should experience little difficulty in mounting any auto set.

1. Read the installation instructions very carefully.
2. If no template is provided, make one.
3. Locate a position for the set on the bulkhead.
4. Using the template, carefully mark the position of the hole or holes to be drilled.
5. Drill the holes, then carefully scrape the paint (both outside and under coat) from the chassis of the car surrounding the holes.
6. If a mounting bracket is used, put it on. If bolts are used, mount the bolts.
7. Mount the set.

1. Before installing a set, one should always very carefully read the installation instructions; that is, unless you are very familiar with the set. A few minutes spent in this manner will often save time and result in a much neater installation.

2. Before you attempt to drill any holes in a bulkhead, it is advisable to make a cardboard template (pattern) to mark the position of the receiver. This is especially true in case the receiver mounts with two or more bolts.

3. To locate the correct position of the receiver, the set itself should be held up against the bulkhead. This is done to see that there is enough room and that the receiver does not interfere with any other equipment beneath the instrument panel. Also, be sure to see that there is ample foot room for both the driver and the front seat passenger. Another thing to watch very closely is that the mounting bolt or bolts do not strike or interfere with the engine in any way. If possible, it is advisable to mount the receiver so that the tubes are accessible without removing the set.

It is usually possible to mount the receiver chassis on the bulkhead over the steering column with the controls extending to the dash. There are several sets on the market with the controls attached directly to the set. If a receiver of this type is to be installed, it is necessary to mount it under the dash in such a manner that the controls will be easily accessible.

4. After locating the correct position of the set, use a template to mark the correct positions of the holes with a center punch. By using the template, you will be more certain of properly locating the holes so that the set will be mounted straight.

5. After drilling the holes, the next step is to very carefully scrape all the paint from around the hole or holes, on the engine side of the bulkhead. This is to provide a good ground for the set, which is essential if you desire to have an installation free from noise pickup in the chassis.

6. The next step is to bolt the mounting bracket to the chassis of the car. If separate bolts are used rather than a mounting bracket, they should be set in place.

11. CONTROL HEADS. Most of the car manufacturers now cooperate with the auto radio manufacturers in providing a space in the dashboard of the car for the installation of a control head. This space is cut out to provide the proper opening of the control head



and is covered with an escutcheon plate. If no opening has been provided in the dash for such an attachment, it will be necessary to use either a control head that will mount under the dash, or a type which will mount on the steering column. The old style installations invariably used the latter type of mounting. Modern installations, however, generally use the former type; that is, a universal type of control head is mounted under the edge of the dash.

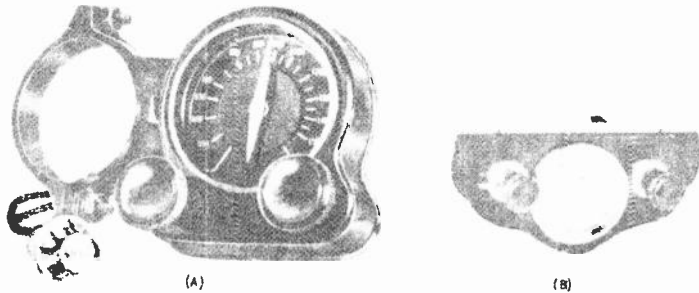

Fig. 27 (A) Photograph of steering column control head. (B) Photograph of an under-the-dash control head. (Courtesy Crowe Nameplate and Mfg. Co.)

Fig. 27A illustrates a control head designed to be mounted on the steering column, while part B shows an under-the-dash control head.

When installing the control head, it is of course, necessary to employ shafts of the proper length. A pair of flexible shafts with casings are illustrated in Fig. 28. These may be obtained in almost any desired length, and with the proper coupling to fit practically any set and control head combination.

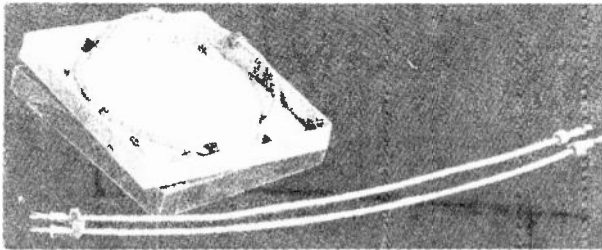

Fig. 28 Picture of a flexible shaft with casings. (Courtesy Crowe Nameplate & Mfg. Co.)

When installing and selecting the shafts, two things should be taken into consideration; First, that the fittings are of the proper type to work freely with the control head set to be used. Second, that the shafts are the proper length so there will be no sharp bends and, at the same time, be out of the way of all other apparatus under the dash. If there should be any sharp bends in

the cable, it would make the control very difficult to operate, especially if "spot" or "automatic" tuning is used.

Many modern auto receivers use push-button tuning. It will not be necessary to study these systems as they are, for the most part, similar to those used in home broadcast receivers. Detailed instructions for the setting of these push-button tuners are always included with each receiver. It is only necessary to advise the service engineer to follow carefully these instructions to insure satisfactory operation.

12. INTERFERENCE ELIMINATION. The elimination of interference in an auto radio installation is the most difficult problem confronting the radio technician. In modern cars, this problem has been reduced tremendously, due mainly to the cooperation of the car manufacturer. If the set and car are both of modern design, the ignition interference may be eliminated quite easily without impairing the operation of the car in any manner.

In spite of this advancement, there still exists cases where the elimination of interference is a long and difficult task. What seems adequate measures for one car is insufficient for another of the same make and model. Each interference problem becomes a case in itself and requires individual remedies. If all the electrical equipment of the car, including spark plugs, could be shielded, there would be very little, if any, ignition interference. Although this is done in airplane motors and wiring, its cost is prohibitive in the competitive manufacture of automobiles.

To eliminate ignition interference in a minimum of time, a good knowledge of the ignition system of the car is essential. The following paragraphs give a brief description of the operation of the ignition system of an automobile.

In order to ignite the vaporized gas in the engine's cylinders, the spark plugs must be provided with a source of high voltage. This voltage is obtained from a 6-volt storage battery by the action of the ignition coil, which is a step-up transformer having a ratio of about 2000 to 1. Six volts applied to the primary produces a voltage of about 12,000 volts across the secondary. This high tension secondary voltage is directed to the proper spark plug by the distributor.

As the engine rotates, breaker points open and close, completing the primary circuit of the ignition coil. A sudden flow of current, which is about 3 amperes, causes a voltage to be built up across the secondary. This high voltage is discharged across the gap of the spark plug, thus igniting the gasoline vapors in that cylinder. The breaker points open once for each cylinder every second revolution of the engine. A 6-cylinder car with the engine turning over 2000 r.p.m. gives 100 sparks per second. This 100-cycle frequency causes no appreciable disturbance.

Each high tension circuit has inductance and capacity with respect to the car body, which makes it an oscillatory circuit. This oscillatory circuit radiates energy at each spark. The fundamental frequency depends upon the length of the ignition wires and their placement in relation to adjacent metallic objects.



As stated previously, due to the effectiveness of the shielding of the modern set, the elimination of motor interference is often a very simple problem. Sometimes it is only necessary to install three or four parts which come with the radio. This will be true only if the set is installed in a late model car. Most auto radio manufacturers supply two condensers and a distributor suppressor with each auto radio. This equipment is considered standard with most companies and their installation is considered a part of the installation of the set. If, on the other hand, it is found that the installation of these parts is not sufficient to eliminate the interference, additional time spent and other parts used are considered separate from the installation of the radio.

One of the condensers generally found necessary is an ammeter by-pass condenser. It should be connected between the ammeter battery terminal and a suitable ground. Be sure that all the paint has been removed from the point where the condenser is grounded to the chassis of the car. The purpose of this condenser is to eliminate interference at the breaker point. The battery supply lead of the receiver is generally connected to the same terminal.

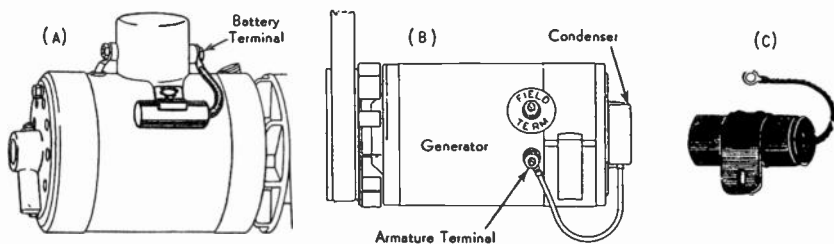

Fig. 30 (A) Picture of car generator, illustrating method of attaching and wiring generator condenser. (B) Picture of car generator with field terminal brought out to a binding post. Illustrating method of mounting and wiring condenser. (C) Picture of generator condenser.

The second condenser is a generator by-pass condenser; it is connected between the terminal on the generator side of the cut-out and the generator frame. Again, be sure that the condenser is well grounded to the generator frame. The connection is illustrated at A in Fig. 30. Quite a few modern cars have the field terminal of the generator brought out to a separate terminal post on the generator. If this is the case, be sure that you do not connect the condenser to this terminal. If you should accidentally connect a condenser to the field, it is liable to burn out the generator, in addition to being ineffective in reducing the generator whine. The field terminal is shown at B in Fig. 30. Fig. 30C illustrates the generator by-pass condenser.

The distributor suppressor is for the purpose of suppressing interference caused by the distributor. To install a distributor suppressor, remove the center wire from the distributor head, insert the distributor suppressor, then insert the center wire in the opposite end of the suppressor. If, as will most likely be

the case, the suppressor has screw type ends, it will be necessary to cut the wire. To install this type, cut the wire coming from the center of the distributor about one or two inches from the end of the distributor. Now, pull the leads out of the distributor and screw the suppressor on the end of this wire. Next, screw the other end of the suppressor on the main lead. After making sure that the lead is securely fastened to the suppressor, replace the end of the wire in its original position, in the center of the distributor. When installing a radio in a modern car, it is unnecessary to install any other suppressor. This is advantageous

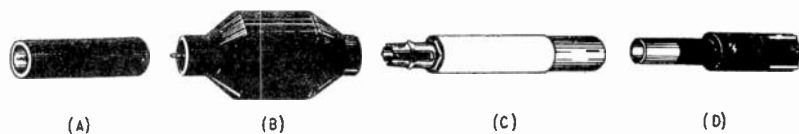

Fig. 31 Distributor suppressor. A, C, and D are pictures of ordinary distributor suppressors having different type mountings. B is a special low-resistance, shunt type distributor suppressor. (Courtesy Philco Radio & Television Corp.)

because the addition of several suppressors impairs the operation of the engine. A new type of distributor suppressor is now on the market, which is practically as effective as the ordinary suppressor but still does not affect the operation of the engine nearly as much. Fig. 31A shows an ordinary suppressor, and Fig. 31B illustrates the newer type of distributor suppressor. Two other distributor suppressors are illustrated at C and D in Fig. 31.

The latest Ford V8 cars do not require suppressors for any purpose. They do, however, require the condensers mentioned previously.

The reason for the spark plug suppressor is as follows: The firing of the spark plug generates strong R.F. oscillations. The wiring of the ignition circuit forms the oscillatory circuit. These oscillations are radiated by the wiring of the car. If resistance is inserted in an oscillatory circuit, the oscillations are damped. This is exactly what the spark plug suppressors do. In reality, the average suppressor is merely a resistor having a value between 10,000 and 25,000 ohms.

13. TESTS TO DETERMINE INTERFERENCE PATHS. It is assumed at this point that the receiver is in proper working order and is properly installed. It is also assumed that the "standard" interference-suppression measures which have already been described have been applied but do not succeed in eliminating the interference completely. If such is the case, the first thing to do is to determine definitely whether the interference comes from a source *outside* the car or from a source *within* the car. If it comes from within the car, it is important to find out how it is reaching the receiver. It may reach the receiver via the antenna. It may also find its way in by direct pickup by the receiver battery wires. When this is known definitely, it will furnish some clue to the

most effective steps to be taken next. Of course, if the interference appears only intermittently and disappears as soon as the car has travelled to another location, it is most likely of external origin. However, there are many cases where the radio receiver is steadily noisy due to external interference when operated anywhere in a location of very wide area; possibly an entire town. This is very often the condition in rural communities having electric light transmission lines with leaky insulators, or having lines which pick up excessive atmospheric radiations and re-radiate the impulses. In such cases, the auto radio set may be noisy when operated anywhere in the town, yet the installation itself is not at fault. In such cases, and others, the serviceman probably knows the fact, but he must have some method of determining definitely whether interference which is heard in a new auto radio installation (or an old one which is to be serviced) is of external or internal origin. There are two conditions under which such a test may be made. They are:

1. Test in a noisy location to determine whether the operation of the car and all electrical appliances on it makes any difference in the noise intensity.
2. Test in a spot free from all external electrical disturbances to see if the operation of the engine and all electrical appliances on the car cause any noise in the receiver.

We will now consider these tests in the foregoing order:

(1) Test in a noisy location: If the serviceman is not equipped with a shielded cage which he can run the entire car into, and the vicinity of his shop is not entirely free from electrical disturbances, he must make the test under noisy conditions. The receiver should be turned on (without the car engine running), and the volume control turned all the way up. If any noise which is heard is "tuneable", the receiver should be tuned to bring in with greatest volume whatever noise is present. However, this should be a point where no broadcasting signal is heard. The noise should be observed carefully so that its intensity may be remembered fairly accurately for comparison later.

(a) The lead-in wire should now be disconnected from the receiver. If this makes the noise disappear, or greatly reduces its intensity, it is undoubtedly due to interference originating outside of the car being picked up by the aerial wire and fed to the receiver. In this case, nothing much can be done about it. On the other hand, if the noise still persists undiminished in intensity when this is done, it indicates that the receiver itself is probably noisy. In this case, loose connections, a faulty rectifier or vibrator, etc., should be looked for in the set.

(b) The engine should now be started (with the lead-in still disconnected from the receiver.) If the receiver is more noisy than it was with the engine shut off, it indicates that interference from the ignition system of the car is reaching the set by way of its battery wires or through the chassis.

(c) With the engine still running, the various electrical

appliances on the car (heater motor, electric windshield wiper, lights, etc.) should be turned on, one at a time, and the effect of each on the noise should be noted. Any appliance that increases the noise requires a by-pass condenser and possible shielding of its leads. The engine should now be shut off.

(d) The lead-in wire should now be reconnected to the receiver and the noise noted. Then the engine should be started. If the noise increases greatly, it indicates that high-frequency interference from the ignition system is reaching the aerial (assuming that the lead-in is well shielded).

(e) Now, to complete the test, the car should be run for several blocks with the set turned on. Notice whether the noise increases when the car is in motion. If it does, it indicates that static discharges are being generated by the front wheels, the tires or the brake linings. It is well to run the car over bumpy cobblestone streets or a bumpy road during part of the test, so that any noises which may be caused by loose connections either in the set or in the car will also be revealed.

14. ELIMINATING RECEIVER WIRING OR CHASSIS PICKUP. A step-by-step procedure which will be found useful when attempting to eliminate all remaining interference which may still be present after the "standard" suppression methods have been applied and the tests outlined have been made will now be presented. Receiver wiring and chassis pickup will be considered first.

1. If the foregoing tests indicate that the interference is finding its way into the receiver by way of the receiver battery leads or shielding, go over all ground connections and make sure that they are clean and tight. Remember that painted or rusted surfaces, parkerized lock washers, etc., do not permit good electrical contacts to be made. All metal contact surfaces should be scraped clean and bright with emery cloth or a suitable file. If the receiver does not contain an effective battery line filter, a small choke coil consisting of 10 to 20 turns of #18 bell wire wound on a  $\frac{1}{2}$ " or  $\frac{3}{4}$ " form and connected in series with the hot "A" lead between the set and the battery is often effective.

2. Excessive noise may also be caused by an imperfect grounding contact between the receiver chassis and the car frame. When the receiver is bolted to the bulkhead or firewall between the engine and driver's compartments (or to the instrument panel) it is important that all paint be scraped off at the area of contact and that all bolts be tightened firmly to assure good electrical contact between the receiver case and the metal of the car.

3. Interference may be picked up by the battery leads of the receiver if they are run through the engine compartment. They should be re-routed through the driver's compartment instead. Try grounding the sheaths on the tuning and volume control cables to the receiver case by means of a screwdriver. If this reduces the interference, these sheaths should be bonded to the receiver case with copper shielding braid.

4. If a separate speaker is used, the shield of the cable between it and the chassis should be well grounded at both ends.

If an unshielded cable between radio chassis and speaker is used, proper filters should have been built into the radio set to eliminate motor interference. It is well to check the efficiency of these filters by connecting a .01 mfd. condenser between each lead in succession and ground. If the condenser reduces the interference, it should be permanently installed.

15. ELIMINATING INTERFERENCE REACHING THE ANTENNA. The case where persistent interference gets to the antenna will now be considered.

1. First be sure that the aerial lead-in wire is properly shielded right from the receiver case to the aerial itself and that this shield is properly grounded at both ends.

2. If the interference still continues the next step is to determine whether it is caused by the high-tension or the low-tension circuits. Remove the high-tension lead between the ignition coil and the distributor (remove both leads if two coils are used) turn on the ignition switch, and turn the motor over by hand (with the radio set turned on). Do not use the self starter for this purpose, as both the sound it makes and the electrical disturbances it will set up will prevent you from hearing the clicks which are to be heard. If clicking from the breaker point interruptions is heard in the loudspeaker, the indication is that part of the interference at least is heard from the low-tension circuits or breaker points. If no clicking is heard, the low-tension circuit may be removed from suspicion. In this case, pass on to test No. 3.

If clicking is heard, remove the primary lead running from the ignition coil to the breaker points on the distributor and either shield it with shielding braid or replace it with a piece of #14 shielded low-tension cable. The shield of this cable should be grounded in two places with connections as short as possible. If necessary, either shield or replace the lead from the ignition switch to the ignition coil with #14 shielded low-tension cable, making good soldered ground connections to the shielding. Care must be taken with the shielded leads so that the connections to the coil switch or distributor are not grounded by them. Never use a by-pass condenser on the breaker side of the primary of the coil, as the operation of the motor will be affected. If one must be used, connect it to the battery terminal of the coil.

The breaker points should be inspected. If they are badly burned or pitted, or dirty, they should be filed flat with a special thin file or stone made for this purpose, and should be adjusted for the proper opening in accordance with the car manufacturer's instructions so that a clean break is obtained. The test for clicking should now be made again to make certain that the interference originating in the low-tension circuit has been completely eliminated.

3. If interference is still present after the low-tension circuits have been attended to and the clicking test gives a negative indication, the high-tension circuits must be considered



next. The ignition circuit should first be put in good order. The spark plugs should be removed from the cylinder head and inspected. If they are fouled, they should be cleaned; new ones substituted if necessary. Otherwise, the gap should be checked with a thickness gauge and adjusted. The gap separation should be about .025 inch for low-compression engines and about .020 inch for high-compression engines. The spacing of the spark plug electrodes is important, since the greater the gap resistance, the greater is the tendency to reduce the high-frequency oscillations. However, if larger gaps than these are used, the interference will increase.

All high-tension ignition cables should be inspected next. Grease and dirt should be cleaned off. If the insulation is brittle and badly cracked, new wires will have to be installed, for the rubber insulation over these cables is very leaky at radio frequencies if it is dry and cracked. All connections to the suppressors and plugs should be tight and secure. The distributor cap should also be inspected and cleaned. If it is cracked at any spot, it should be replaced, for leakage will occur.

4. If interference is still present, the location of all high-tension wires should be studied. All low-tension wires which run parallel to, or in the field of the high-tension circuits, act as carriers and they should be moved whenever possible, or the high-tension wires re-routed. In cases where the high-tension duct is used to house low-tension wires, the removal of the low-tension wires from the duct will usually be found sufficient.

5. The rotor arm of the distributor does not make actual contact with the distributor points, except in very few cases, for a very good reason. The small air gap of a few thousandths of an inch provides mechanical clearance and prevents the flow of current to the spark plug for a very short time in order to allow the secondary voltage to build up to the proper value. If the gap is more than between .001 to .004 inch wide, the amount of interference that may be generated is large, and the gap must be reduced, but care must be taken that the rotor does not brush any of the contacts.

6. Interference conveyed to the auto radio by re-radiation means that radiation from the interference source is picked up by some other wire (such as the tail light wire, for instance) or other metallic current path (such as a copper oil pipeline coming through the engine bulkhead) which acts just like a radio receiver aerial. An interference or "noise voltage" is thereby generated in this conducting circuit, and a noise current may flow in it. This current flowing through the conductor causes a radiation of energy from it (re-radiation) of the same, or some other frequency. This re-radiated energy may reach the aerial or other wiring of the auto radio installation, causing interference to be set up in it. The process is cumulative, so that in many cases a number of parts and wires in the car seem to be the source of noise, when they are actually re-radiating electrical disturbances received from some other source in the car. This makes it difficult to locate the actual source of the interference.

Conveyance of interference by direct conduction or re-radiation may be effectively minimized by electrically bonding the conducting or re-radiating conductor to the chassis of the car. Low-resistance flexible copper braid is employed extensively for this purpose. This braid is really a tubular copper braid which may be used either for shielding wires or as a bonding braid.

7. In order to test quickly whether bonding certain members reduces the interference, it is convenient to make up a few test bonding leads composed of 18-inch pieces of shielded bonding braid terminating at each end in a large size battery clip for quickly clipping one end of the braid to the member in question and the other end to the chassis of the car. These temporary bonds may be clipped in place, one at a time, where experience has shown that trouble exists, and then removed, one at a time, until one is found whose removal increases the motor interference. This should then be replaced with a permanent bond of copper braid soldered or otherwise securely fastened in place. Several by-pass condensers of .5 or 1 mfd. capacity may be provided with leads and battery clips of smaller size to assist in locating points in the various car wiring circuits that require by-pass condensers. Places where these condensers should be tried and where they frequently result in reduction of motor interference, are on the battery side of the ignition coil, on one electric clock lead, on the cigar lighter lead, on the electric windshield wiper lead, on the dome light lead, and if an under-car antenna is employed, on the rear light leads and on the other wires running under the car, such as electric gasoline gauge leads, etc.

8. The dome light wire running from the ammeter over to the door post often picks up considerable interference and because it re-radiates it, it is a frequent source of noise when a roof type antenna is being used. In order to find out whether it is causing interference, disconnect the dome light feed wire from the point of connection (usually behind the instrument panel). If this lessens the interference heard in the loudspeaker, replace the lead and try a .5 or 1 mfd. by-pass condenser from the point to the car ground. If the by-pass condenser does not reduce the interference, insert a 20-turn choke coil wound with #18 bell wire on a  $\frac{1}{2}$ " or  $\frac{3}{4}$ " wooden form, in series with this dome light lead, and close to the hot battery lead feeding the dome light circuit. Leave the by-pass condenser connected on the *battery* side of the choke coil. In some instances, it may be necessary to move the dome light switch to a point on the instrument panel, close to the ammeter.

9. The establishment of good electrical contact between the motor block, motor bulkhead, instrument panel, chassis and body of the car where contact does not already exist, is essential in eliminating interference. In many instances, a good electrical contact between the motor block, dash, and frame of the car will eliminate much of the interference. These electrical connections may be made by connecting together the parts with short pieces of copper braid. Such bonding is particularly necessary on those cars incorporating "floating power", in which the engine is

mounted on rubber blocks. These metal parts of the car must be maintained at a common ground potential by bonding them together. In such cars the bonds from the motor block must be long enough to allow for vibration. A good connection between the instrument panel and the body and frame of the car may aid materially in reducing noises. Special attention should be paid to the thorough grounding of the bodies of cars which employ a wooden body sill, for very often these bodies are not well grounded to the chassis.

10. A good deal of the noise encountered in automobile receiver installations is due to ignition circuit interference being conducted into the driver's compartment from the engine compartment by way of choke and spark controls, copper tubing oil line, cowl ventilator levers, and other controls. From the driver's compartment it may be re-radiated to the antenna system. Every wire, control rod, or pipe that runs from the motor compartment through the dash may radiate interference and they should be grounded to the dash, (wires should be shielded and the shields grounded). Use heavy flexible copper conductor or braid to ground, then to the dash, allowing for any necessary movement of the rods. If the iron rods are rusty, scrape them clean so that the copper bonding conductor may be securely soldered or clamped to them. The wire conduit that runs to the base of the distributor in some cars should also be grounded in the same manner. Sufficient slack should be left in the bonding of all control rods so that the greatest normal movement of the rods will not tear the bonding loose.

11. On some of the recent cars, the steering column is mounted on rubber to absorb road shocks, and is not well grounded. Such steering columns can be veritable racetracks for interference currents unless they are well bonded to the bulkhead or chassis with copper braid of low resistance (preferably soldered for perfect connection).

12. Some interference may also be caused by changes in the resistance of the receiver to ground when another grounded conductor, such as the choke rod, free-wheeling control, speedometer cable, or steering column touches or rubs against the receiver. These controls and cables should not be allowed to touch or rub against the receiver case. In some receivers the remote tuning control cables are grounded to the receiver chassis an inch or so beyond the point where they enter the chassis. This may be a source of interference, and it is best that all remote tuning cables be bonded to the outside of the chassis to be sure that they are at the same potential.

13. In some cases, the interference being heard is intermittent and is caused by loose electrical contacts in the electrical wiring of the car. Connections to all lights, horn button and horn, cigar lighters, etc., should be checked to see that the contacts are clean and the wire connections are tight. It is a good plan to install lock washers on all loose connections. Loose connections may cause excessive "scratchy" noises in the loudspeaker when the car is jolting over a rough road.

14. In a few cases, it may be noticed that interference is present only when a passenger is in the front seat of the car. This type of interference is caused by the fact that some automobiles have wooden toe boards, or floor boards, and if some high-tension wiring runs near the bottom of the engine compartment, the body of the driver or passenger transmits the interference from it to the antenna system. This condition may be checked by getting in and out of the front seat and noticing whether the interference varies in strength. It may be eliminated by placing a piece of copper screening under the floor mat (it may be tacked to the floor board) and grounding the screening securely to the body or chassis of the car. When a wooden bulkhead is encountered, this must also be shielded with copper screening and grounded or the same interference will be experienced.

15. When an under-car or running board type aerial is employed, the treatment of all wires and unbonded parts of the car near the aerial and the lead-in becomes very important. Stop light and tail light leads may have to be shielded and by-passed to ground with .5 mfd. condensers. Since the gasoline feed lines, brake rods, etc., may conduct high-frequency interference currents back from the engine compartment and re-radiate this interference to the aerial, they should be properly bonded to the metal frame of the car.

A study of the foregoing instructions for minimizing ignition interference shows that a considerable number of factors must be considered in this work. While it is rarely necessary to go through every one of the steps presented here and to apply every one of these remedies when installing modern sets in recent cars, it is a fact that the suppression of ignition noise to an allowable level is a very difficult task in some cars; especially old ones. Experience provides very tangible and definite assistance in this work.

15. WHEEL STATIC. The general term "wheel static" is given to interference caused by the electrical charges accumulated on the wheels by either friction of the tires on the roadway or by the action of the brakes on the brake lining. Constant discharges of electric charges will cause objectionable interference in the receiver.



Fig. 32 Wheel static eliminator.

A practical method of eliminating wheel static has been to ground the wheels to the car chassis by means of a metal static collector, thus making the wheels and the chassis at the same potential. This procedure is necessary since the grease in the bearing is an effective electric insulator. A static collector is used on each wheel for this purpose. In the case of the front

wheels, which are the worst offenders from tire static, the static collector consists simply of a spring placed inside the hub cap with a point making contact on the end of the front axle. This device is held tightly in the hub so that the point on the end of the axle will always insure good electrical contact. For the rear wheels the static collector consists of a piece of spring metal with a carbon brush attached. It is mounted in such a position that one end makes contact with the brake shoe mechanism and the carbon brush makes contact with parts which are attached directly to the brake drum. This will short-circuit any capacity effect which may exist between the brake drum and the brake shoe and eliminate any charges which may be generated through the friction of the brake lining. Fig. 32 illustrates a wheel static eliminator.

In spite of the static collector and other means employed, there has been persistent cases of wheel static which have baffled servicemen: An eventual remedy is often found by a thorough study of each case. Study is being carried on for a possible remedy of all stubborn cases of this sort.

### PART THREE - RECORD PLAYERS

16. PHONOGRAPHS. Many years ago the old mechanical phonograph was the main source of home entertainment. However, the advent of radio in the early twenties started a decline of the phonograph which lasted until recent years. Now that radio is more or less a household utility the phonograph has again become a leading entertainment item. Its main attraction is that with it one can hear the leading entertainers of the world at the time and place suitable to the listener, instead of having to wait for scheduled broadcast.

Of course the phonograph of today differs radically in the method of reproduction from the old mechanical systems. In those days, the needle following the groove in a record caused a diaphragm to vibrate. This diaphragm acted as a medium to move a column of air which was amplified through a long horn. The modern form of phonograph first converts the sound as recorded on the record into electrical energy which is in turn amplified through an audio amplifier and reproduced through a loudspeaker. Inasmuch as the modern phonograph is usually operated in conjunction with a radio receiver, we are including it in this lesson on special receivers.

At this time the recording systems will not be discussed. It is only necessary to point out that all recording is now done electrically, allowing the control of tone or quality at will, thus compensating to a great degree for the record's frequency characteristic. The records used are now all of the so-called lateral cut type, in which the reproducing needle is caused to vibrate in a horizontal plane at the same frequency as recorded on the record. Fig. 33 shows an exaggerated view of this method of recording. This groove is run spirally from the outside of the record toward the inside.

17. THE PICKUP. The most important part of the reproduction system is the electric pickup. This unit converts the mechanical vibrations of the pickup needle into electrical energy. There are two general types of pickups used for making this conversion. They are the magnetic pickup and the crystal pickup.

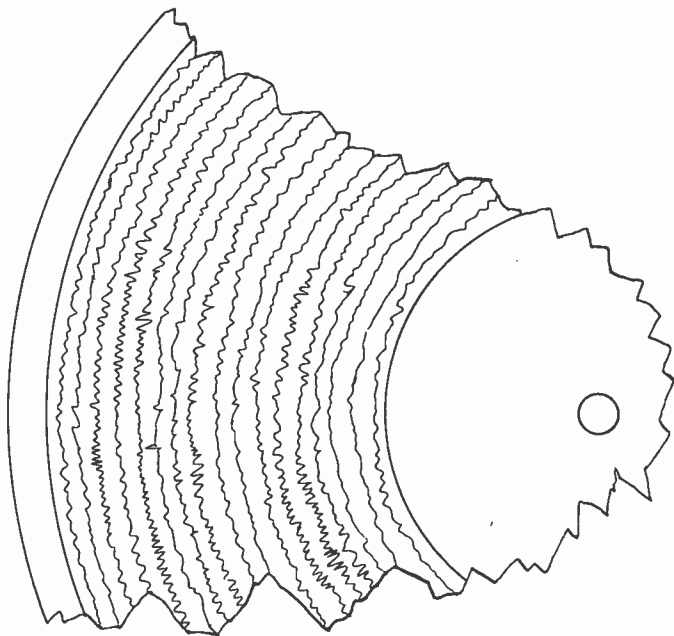

Fig. 33 An exaggerated view of a lateral cut record.

Fig. 34A illustrates a typical magnetic type pickup, while B shows the same pickup with the cover removed. The principle of operation of this pickup is as follows: A permanent magnet sets up lines of force through the pole pieces. A coil lying in this field is, of course, affected only when the flux is varied. Now, if the armature is vibrated by some external means (in this case, the record) it will shorten and lengthen the distance or path between the pole pieces. This in turn causes an increase and decrease of the flux linking the coil, and thus induces an alternating voltage in the coil. The frequency of the signal in the coil will correspond to the vibrations of the armature. The coil is connected to an A.F. amplifier through a suitable matching transformer, and its output is amplified and reproduced through a loudspeaker.

As can be seen from the above description the magnetic type of pickup is necessarily quite expensive. To eliminate a great deal of this expense the so-called crystal pickup was developed. It depends upon the piezo-electric effect for its operation.

Without going into this effect too deeply, let us state that certain salt crystals have the property of providing minute voltages across their faces when they are distorted along their axes. This distortion, of course, must occur as an alternating effect and produces an alternating emf.

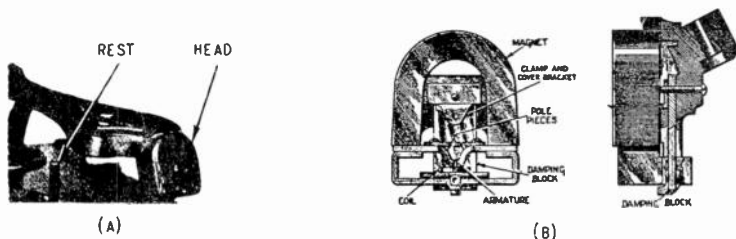
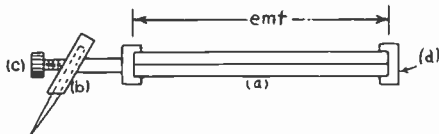

Fig.34 A magnetic pickup

In Fig. 35 is shown a sketch of a typical crystal pickup. The Rochelle salt crystal (a) is held at one end by the fixed clamp (d). The other end of the crystal is clamped by the combined needle holder and clamp (b). The screw (c) holds the needle in place. When the needle is vibrated by the record, it produces a twisting distortion in the crystal and in turn an alternating emf is induced across the faces of the crystal. This emf is amplified through an audio amplifier and reproduced in the usual manner.

Fig.35 Outline drawing of a crystal pickup.



In both magnetic and crystal pickups the armature is supported in rubber which serves both as an elastic mounting allowing comparatively free movement of the armature, and as an insulating member. The placing of this armature is critical in both units. In the case of the magnetic pickup, if the armature is off center, it will hit the pole pieces, damping one half of the alternating cycle and thus creating distortion in the reproduction. In the crystal pickup if the armature is off center, the crystal has a preliminary distortion. When vibrations are set up a non-symmetrical waveform results giving distorted reproduction. In the latter case, where distortion or weak output is traced to the pickup, the serviceman should not under any circumstances attempt to repair the unit. Always change the unit for a new one. The comparatively low price makes this change possible. However, in the case of magnetic pickups, it is possible for the serviceman to make repairs. He should always follow instructions as issued by the manufacturer of the pickup.

17. TYPES OF RECORD PLAYERS. Most radio receivers of modern design have included some method of connecting a phonograph into the circuit. In some cases, the phonograph and switching mechanism is included in the same cabinet. Such a unit is known as a radio-phonograph combination, an example of which is illustrated in Fig. 36. In other cases, connections are made through terminals on the receiver chassis to an external phonograph. This unit may be any one of several types; the only precaution necessary is



Fig.36 A radio-phonograph combination

that the phonograph circuits in the two units are suitably matched. A popular type of record player is illustrated in Fig. 37. When a crystal pickup is used, it is possible to make connection through a radio-phonograph switch direct to the audio section of the second detector or first A.F. tube. Usually these connections are through a resistance coupling arrangement. However, when a magnetic pickup is used, it is necessary to use a transformer to couple the pickup to the grid of the A.F. tube. This is necessary because the magnetic pickup usually has a low impedance compared to the grid circuit of the audio tube.



Fig.37 A popular type of record changer.

In recent years, a new type of record player has become quite popular. This unit uses a low power modulated oscillator as a transmitter and the signal radiated is picked up by the broadcast receiver exactly as any broadcast signal is received. These units are usually tuned between 530 and 625 kc. The variation allows the selection of some frequency band in which no signal is received on the receiver with which the record player is used.

Fig. 38 shows a schematic diagram of a typical unit of this type. Two tubes are used; one, the 25Z6G is connected as a half-





3. Placing second record on the turntable.
4. Swinging the pickup to correct position and setting on record in position to start playing.

Let us examine Fig. 39 and see how the first step is accomplished. If you will examine any standard record, you will find on the center of the record and at the end of the playing groove, an eccentric groove (a in Fig. 39) connected to the regular playing grooves. There is no recording in this groove. When the recording has been played, the reproducing needle is led into the eccentric groove and as the record turns the pickup arm moves back and forth through a distance of approximately  $\frac{1}{4}$ ". This is sufficient to engage a friction catch which starts the automatic record changing system in operation.

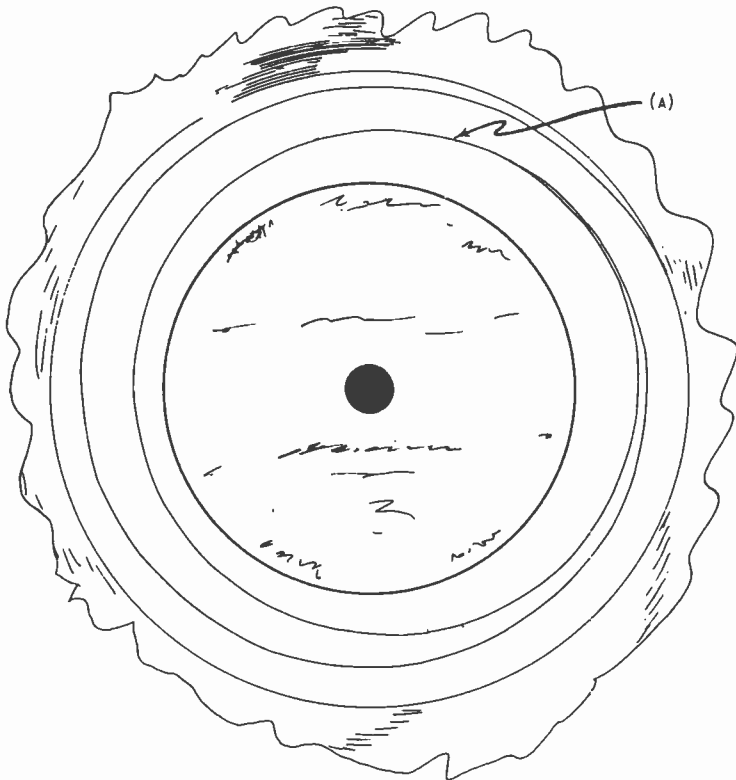

Fig. 39 Illustrating the eccentric groove near the center of a record.

For the balance of this explanation let us look at Fig. 40. The rocking of the pickup arm causes a clutch (13-41) to engage, and the cam and gear assembly (09-32) starts rotating. On this assembly are two cams in which we are interested. One is the

circular cam in the center of the assembly. The other is the irregular cam which extends outward from the center and back again. Now, as this assembly is rotated, the circular cam first causes the arm (66346) to be raised, which in turn raises the pickup and arm assembly and lifts the pickup off the record. By this time, the irregular cam has reached the extension on the right end of the arm (56-153). This cam forces the arm outward and in so doing it accomplishes two purposes. First, it moves the pickup arm away from the record just played. This is done by the engaging of a pin on a short arm connected to the pickup arm post with a square hole on the right end of 56-153. Examination of Fig. 40 shows how this is accomplished. The second purpose of this arm is to start the operation which releases the new record and drops it on the turntable. This operation is performed through the left end of arm (56-153) and rocker arm (56-132). The movement of these arms causes a clutch (not illustrated) to engage and the link (07-28) to be pulled to the left. Following the action by looking at Fig. 40, you will see that the sector gear will rotate and turn the record shelf supporting post (15-10).

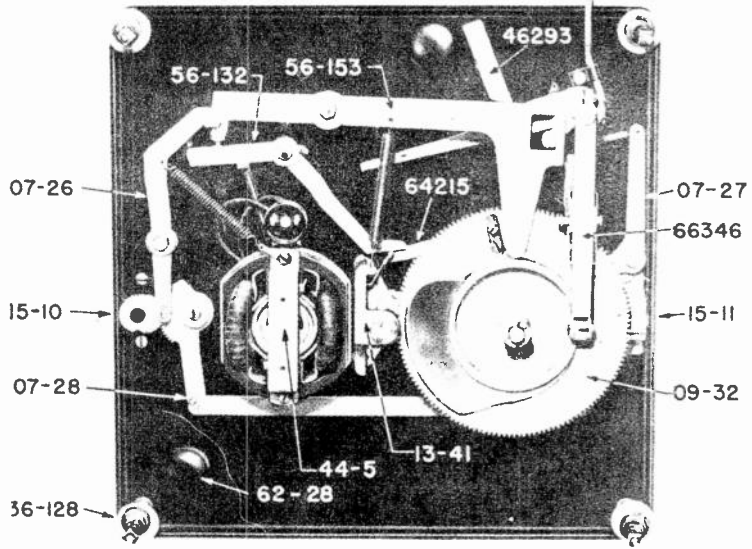

Fig. 40 Illustrating the mechanism for one type of automatic record changer.

As this post turns, the record holder shelf also turns, and as it turns the knife edge separator wedges between the bottom record and the balance of the records on the shelf (see Fig. 41). As the rotation of the record shelf continues, the bottom shelf moves out of the way and the bottom record of the pile drops on the turntable. As the post is moved back, the knife edge blade moves

out of the way and the record pile drops to the regular record shelf.

Now let us return to Fig. 40. As the cam continues to rotate, the arm (56-153) is allowed to swing back to its position at the start of the record. This brings the pickup arm back to its starting position. Meanwhile the pickup has been held off the record surface by arm (66346). Now, as the pickup is over the correct starting point on the record, the circular cam drops down to its original level and in turn the arm (66346) drops back and allows the pickup to rest on the record. This completes a full cycle in the record changing operation.

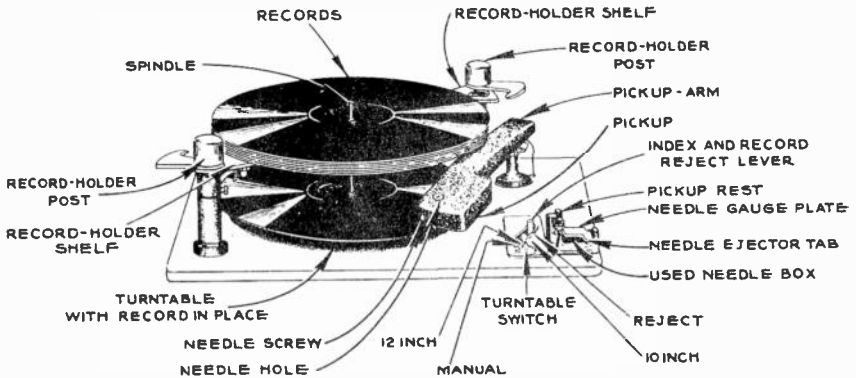

Fig. 41 A top view of an automatic record changer.

As stated above, the basic operations in automatic record changers are the same, regardless of the make or unit. To elaborate further by illustrating other types of units would be confusing. By studying the operations as they occur in the unit being serviced, the service engineer can usually ferret out the trouble with little delay.



# Notes

*(These extra pages are provided for your use in taking special notes)*

The text of this lesson was compiled and edited by the following members of the staff:

G. L. Taylor  
President and Chief Engineer  
Midland Radio & Television Schools, Inc.

C. L. Foster  
Supt. of Instruction  
Midland Radio & Television Schools, Inc.

C. V. Curtis  
Chief Instructor  
Midland Radio & Television Schools, Inc.

R. E. Curtis  
Technical Drafting  
Midland Radio & Television Schools, Inc.

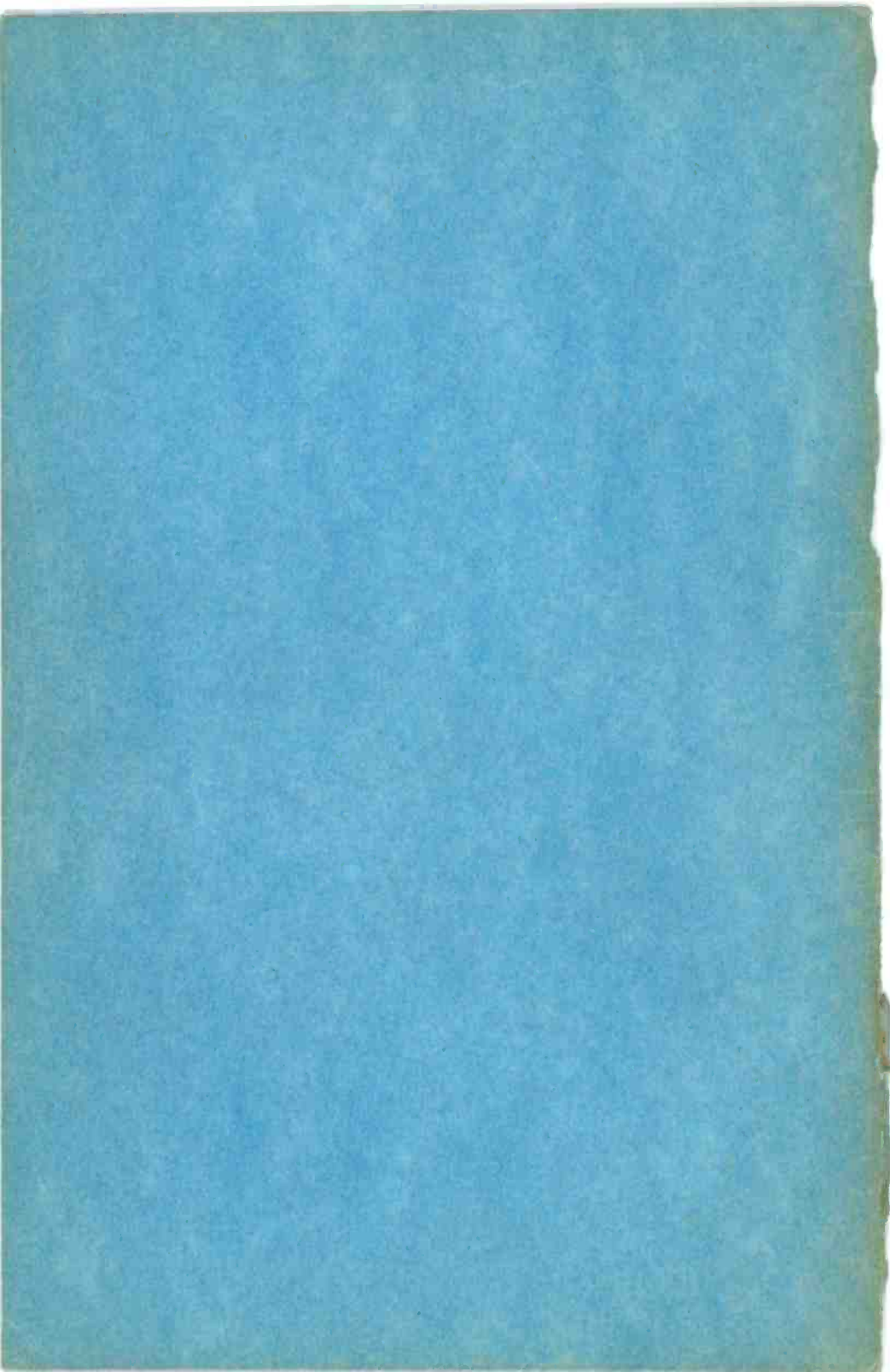





**MIDLAND RADIO  
AND TELEVISION  
SCHOOLS  
INC.**

**POWER & LIGHT BUILDING, KANSAS CITY, MISSOURI**

**UNIT  
NO.  
2**

**INTERFERENCE  
ELIMINATION**

**LESSON  
NO.  
8**

# YOUR FOUNDATION

.....SEE THAT IT IS STRONG AND FIRMI

One Sunday afternoon some time ago, I went out for a Sunday afternoon drive around the city with no special destination in mind. My way took me through some of the poorer section of town. While passing, I could not help but have a rather depressed feeling upon seeing the many shabby, run-down houses, badly in need of paint. But what took my notice especially was the fact that the foundations on practically all of them were beginning to cave in, allowing the house to sag beyond possible repair.

As I was leaving this poorer section, I was rather startled to see a house which, although as old or even older than the rest, was in excellent condition, with fresh paint upon its sides, a neat white fence bordering its yard, and which was not sagging nor cracking, and I particularly noticed that it had a strong, sturdy foundation. After seeing the pitiful condition of the other houses, it was, indeed, a sight for sore eyes and I could not help but stop and admire it.

The contrast showed plainly that the builder of this house had taken pains and care to see that the best of material went into its construction, and that a foundation was made for it to rest upon which would stand every strain and stress placed upon it....one which would weather the years and not allow the house resting upon it to sag and break down as time passed on.

Naturally, this is the kind of a house that you and I and every one wants....one which is built to stand any and every test to which it is put. But did you ever realize how closely the construction of a house resembles the construction of our lives? Our future depends upon how we plan and build the foundation for it in early life. The type of material which we put into the building of our future will have direct bearing upon how we "weather the years" and "stand the stress and strain" placed upon us during the years to come.

Every one wants to be a success. And those who have built a strong foundation for themselves in early life and prepared for employment in a growing industry such as Radio and Television can easily be distinguished from those who neglected their foundation and simply relied upon "luck" to bring success.

NOW is the time to build YOUR foundation for the future....you have the opportunity to use the finest material with which to build it....Midland training. Insure your future in the fascinating and promising field of Radio and Television by building your foundation the Midland way. See to it that your success will be so apparent that it will be noticed and talked about by all your friends!

Copyright 1941

By

Midland Radio & Television  
Schools, Inc.

PRINTED IN U.S.A.



KANSAS CITY, MO.

# Lesson Eight

## INTERFERENCE ELIMINATION



"Locating radio interference is one of the many activities of a modern service engineer. Complaints of this nature are very frequent, especially in city business districts; therefore the service engineer should be acquainted with the methods of finding and correcting the trouble.

"All of those sounds produced by a loudspeaker, that are not a part of the radio program are called "interference". In this lesson, I will point out the possible sources of this interference and the methods of correction."

1. INTRODUCTION. The best radio broadcasts or even the performance of the most costly radio receiver may be ruined, and very often is ruined, by a condition over which in most cases, neither the broadcaster nor the radio manufacturer has any control. This condition is generally known as interference whether it be caused by atmospheric conditions or by electrical devices of any nature. These electrical disturbances may be transmitted to the receiver by several paths, but are still regarded as interference and are usually objectionable to the listener.

Locating the sources of radio interference is one of the many activities of the modern service engineer. Customers complaints on this subject are numerous, and therefore the service engineer should know how to find trouble of this nature; as well as how to correct it when the source is found. In this lesson we will investigate all the possible sources of this interference and the usual methods of correction.

In recent years, a larger number of complaints have been made by customers dissatisfied with the response of their radio receivers due to "noise" or interference. This increase can be attributed first to the constantly increasing sensitivity of modern receivers as well as the increased popularity of short wave receivers. It is also due in part to the rapid increase in the use of electrical devices in the home and the manufacturing plant and office. The increased sensitivity of modern receivers has allowed

the owner to tune in weaker and more distant stations, but at the same time it has increased the noise level in the receiver. It is possible of course that the noise to which the owner objects is natural static. In this case, there is not a great deal the service engineer can do to remedy the situation. However, in many cases, the noise is of such a nature that it can be greatly reduced or eliminated entirely. Regardless of the source of the noise, the service engineer will be expected to give the set owner as quiet and noise-free operation as is possible.

It was mentioned above that the noise found may be either natural or "static", or "man-made" noise. For our first consideration let us see what is meant by natural static.

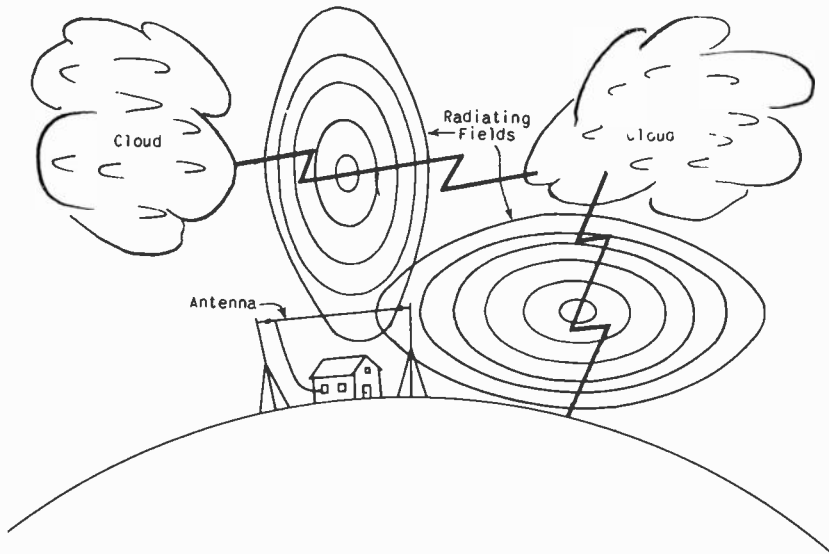

Fig. 1 Illustrating how magnetic fields are produced by lightning discharges between charged clouds or between a cloud and ground. This, and other atmospheric discharges generate "natural" static.

Natural static is caused by some electrical disturbance in the atmosphere, such as lightning, which produces electromagnetic waves very similar to those radiated from a broadcasting station. These fields are usually extremely broad in wavelength and thus influence the receiver operation, regardless of the frequency to which it is tuned. In Fig. 1 is shown how these electrical disturbances set up a radiating field. Inasmuch as there is little that can be done to correct natural static, we will concern ourselves in this lesson with the sources and methods of correction of man-made interference.

2. LOCALIZING THE INTERFERENCE. In checking a receiver in which an excessive amount of noise is present, there are two

questions which naturally present themselves. They are:

1. What is the source of the noise, how does it reach the receiver, and what type of noise is it?
2. What procedure should be followed and what should be used to locate the source of the noise and to correct it?

It is logical that before an interference condition can be remedied, we must first find how the noise reaches the speaker and is reproduced. There are three possible paths by which the noise can reach the receiver; namely:

1. From the power line into the receiver, where it either directly or by radiation produces the undesirable noise.
2. It may originate in the set itself, or
3. It may be coming in through the antenna or ground system.

The usual procedure is to determine if the noise is originating in the set itself, or has its source at some point outside the set. First, tune the receiver to a point where the noise condition is at its worst. Then, without changing the tuning or volume control setting, remove the antenna from the receiver and move it far enough away that there can be no possibility of radiation to the receiver. If there is not a noticeable change in the volume level of the noise, it is obvious that it is not reaching the receiver through the antenna. However, if the noise level does drop appreciably, the antenna is undoubtedly the path by which the noise reaches the receiver. Later in this lesson we will describe noise-reducing antennas.

The next step is to remove the ground wire from the receiver. It is seldom that the noise level will be reduced in this step. However, if there is a definite drop in the noise level when the ground wire is removed, it is an indication of a defective ground. In this case, it is very likely acting as an antenna and is picking up noise from nearby wiring or other source of interference near to the ground lead. An ideal ground connection is a rod driven several feet into the ground as far as possible from any water or gas pipes. The lead to the receiver should be as short as possible, and should be well spaced from water and gas pipes as well as electrical wiring. If such a ground is not feasible, and a water pipe must be used, the lead from the receiver should be connected to the pipe as close as possible to the point where the pipe enters the ground. This is necessary because the joints in the pipe line offer a high resistance due to corrosion, so that a connection far removed from the ground may actually not have any connection to true ground. Hot water or steam pipes are useless due to the many high-resistance joints between the connection and ground. In addition, the use of automatic electric water heaters and oil burners create an electrical disturbance which may be transmitted through the pipes and directly to the ground terminal of the receiver. If a satisfactory ground is not available, the ideal solution is to eliminate the ground and to use a doublet antenna.

Let us assume that we have eliminated the aerial and ground as paths for the noise to enter the receiver. In other words, after removing the antenna and ground the noise is still present. If we now short the antenna post to the ground post, and the noise level drops to a low level or disappears entirely, we can be certain that the noise does not originate in the set itself, but must be entering through the power line.

To determine if the line is the source of the noise, a good line filter is connected to the wall socket and the set is plugged into the outlet of the line filter. If the noise stops, the line filter should be left in position. In a later part of this lesson we will discuss the correction of interference at its source. In connection with line filters, we wish to caution against the use of inferior or unknown products. Many gullible people, seeing almost unbelievable results in street corner demonstrations, buy nothing but an extension plug containing no capacitors, chokes, or resistors. We recommend using products of recognized and reputable manufacturers to eliminate any possible suspicion on this point. In Fig. 2 is illustrated a typical circuit of a line filter. It is always enclosed in a shielded and grounded case to eliminate any possibility of re-radiation.

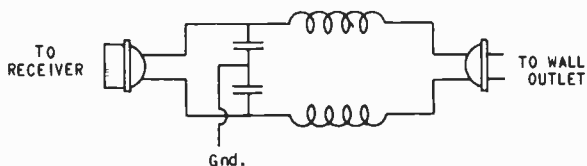

Fig. 2 A typical line filter.

**3. INTERNAL CHASSIS NOISE.** Now let us suppose that our tests have located the noise source as within the receiver itself. It follows that our next step is a thorough check of the chassis. In recent years, the improvement in tube manufacturing methods has removed a great deal of noise trouble from this source. However, it is wise to check each tube by tapping it while the set is in operation. A noisy tube will immediately be found, due to the crackling and scraping noise heard when the tube vibrates. This type of noise is caused by loose elements within the tube. In a few cases, tubes will be found in which arc-overs between elements occur due to warping, and which may not produce noise when tapped. Such tube failures can be found only by substituting a good tube for the suspected one.

If the noise is found to originate elsewhere than in the tubes it will be necessary to localize the noise source. This can be done, as explained in earlier lessons of this unit, by removing one tube at a time starting at the R.F. end of the receiver. When any tube is pulled out and the noise stops, the parts making up that particular circuit should be checked to determine the source of the noise.

In these days of high speed production, one of the most common sources of noise is poorly soldered or corroded connections. These can generally be located by pressing and pulling on the wires to the various soldered points. In all cases an insulated rod should be used to prevent accidental contact with high voltage circuits.

Many times resistors or capacitors may be found defective. Capacitors may develop a small arc between elements or between the elements and connecting leads. This type of failure usually produces a frying noise in the loudspeaker. Resistors may develop a high resistance, or in the case of wire-wound resistors, a tap may become loosened. A loose tap or connection may cause a small arc to form, thus producing extreme noise in the loudspeaker. Many receivers have the complaint of being noisy only when the set is being tuned. This is caused by dust and metallic particles between the plates of the tuning condenser. It is also, in some cases, produced by the "scaling" of the plating on the condenser plates. This condition generally produces a "cracking" or "popping" noise as the receiver is tuned. In extreme cases, the receiver may even have "dead spots" at different points in the tuning range. A favorite "tool" to clean out the dirt between variable condenser plates is the ordinary pipe cleaner. Cotton wrapped around a toothpick also serves the purpose. Care must be taken in this cleaning operation that none of the plates are bent. If plates of various sections were accidentally bent, the alignment of the receiver would be affected and the receiver performance would naturally be impaired.

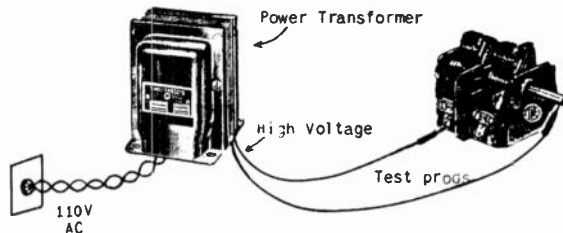

Fig. 3 Arrangement for burning off dust or metal peelings from the plates of a variable tuning condenser.

In the case of scales or peeled plating, it is usually necessary to "burn out" the condenser. This is done by removing all connections from the condenser assembly and connecting the secondary of a high voltage transformer across each section in turn. With the power applied, the condenser should be rotated and the plates gently tapped with an insulated rod to knock out any loose particles. Fig. 3 shows the connections for this procedure. If a high voltage transformer is not available, a 110-volt line may be used, however, a 25 watt lamp should be placed in series to prevent shorting the power line. While cleaning the variable condenser, the rotor wiping contacts should always be cleaned. Cor—

roded or dirty contacts are a potential source of noise.

One of the most difficult types of noise to locate is that caused by audio transformers. Corroded or loose wires and vibration of loose laminations are the source of this interference. If an audio transformer is suspected as a source of noise, it can be checked by substituting a resistance-capacity connection as shown in Fig. 4. Other sources of noise to be checked in stubborn cases are loose pilot lamps and fuses, bad contacts in "off-on" switches and volume controls, loose tube shields, etc.

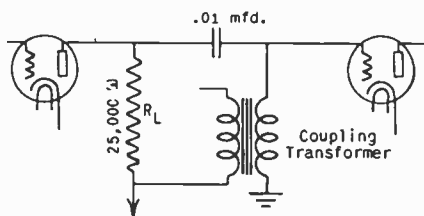

Fig. 4 Showing how to substitute a resistance-capacity coupled transformer for an audio transformer to test the transformer windings for noise.

A source of continued annoyance to service engineers is the complaint of high noise level in a receiver due to the design of the receiver itself. This type of noise can usually be described as tube hiss. Listeners attempting to tune weak or distant stations most naturally use nearly all of the available sensitivity of the receiver, which, of course, produces a large amount of noise. If the customer is properly educated, there should be no difficulty for the service engineer. It is possible, however, for the tube hiss to be excessive even with normal sensitivity. In superheterodyne receivers, if the proper signal voltage to oscillator voltage ratio is not maintained, small noise currents will be generated in the mixer tube circuit and amplified by the receiver. Normal tube hiss is kept low by maintaining the correct values of plate, screen, and bias voltages on the RF and IF amplifier tubes, as well as the mixer and oscillator tubes.

**4. INTERFERENCE VIA THE AERIAL.** Most noises enter the receiver through the aerial and the lead-in wires. When interference is noted, the first question that arises is whether the interference is natural or man-made static. Natural static is most noticeable during thunderstorms, heat, lightning or dust storms. Therefore, if the interference is extremely noticeable during such disturbances, there is not a great deal that can be done to eliminate the noise, for without a doubt, natural static is the source. Recently some receivers have incorporated a noise limiter circuit which has been the only method of reducing the effect of natural static to any marked degree.

Before considering the various methods of eliminating man-made interference, we should consider what it is and how it is distributed.

A radio antenna intercepts the high frequency waves emitted by broadcasting stations and makes the signals audible through



the speaker. Unfortunately, the noise impulses which enter the set are also in the form of high frequency waves (untuned and uncontrolled) and are closely identical with those emitted from the broadcasting station. Consequently, they are made audible from the speaker in the same manner and through the same circuits. Almost any piece of electrical apparatus, large or small, is a potential source of disturbance to the receiver. Wherever an electric spark is set up, waves of high frequency electrical energy are sent out. If these devices operate from the same wires that are supplying the house with electricity, these wires will act as an aerial for the noise source. Part of this noise may enter the set directly through the AC power line which, as previously stated, can generally be eliminated with a suitable line filter. But, most of the noise is picked up by direct radiation from the noise-creating device itself or from the power line which is acting as an aerial for the device.

Since both the broadcast signal and the noise signal are of a high frequency character, they are amplified equally well through a radio receiver. When radiated noise signals are induced in the antenna or lead-in wire, no device applied to the receiver will separate broadcast signals from man-made static.

There are two general methods of suppressing the interference due to noise-creating electrical apparatus. One is to eliminate the source by discarding the apparatus or by placing it in such a condition that the trouble will not occur. The other is to confine the electrical waves set up by the apparatus to a very small area, or to locate the antenna outside of the radiation field and thus prevent the noise impulses from reaching the set. We will first consider the effect of the antenna design and location.

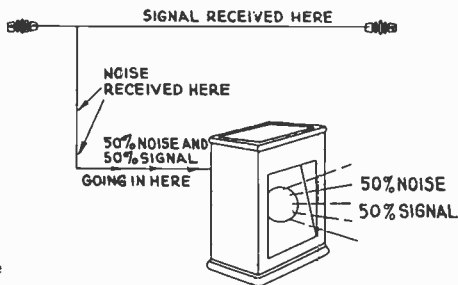

Fig. 5 Illustrating noise pickup in the lead-in wire.

In the reception of a radio signal, we know that the antenna is very important. The receiver amplifies and reproduces only that signal picked up by the antenna. It is equally true that any noise picked up in the antenna or its lead-in will be amplified and reproduced the same as the broadcast signal. The only solution, then, is to eliminate the objectionable noise signals before they enter the radio receiver.

Let us first consider the condition where the noise impulses are picked up only in the lead-in wire as illustrated in Fig. 5. In this case, the total signal input to the receiver consists of a combination of the noise signal picked up in the lead-in and the broadcast signal picked up in the antenna. In turn, the output of the receiver will be a combination of the two signals.

Fig. 5 illustrates the conditions existing when the signals from a broadcast station are intercepted by the antenna proper and the noise impulses are picked up on the lead-in. The total input to the receiver then consists of both the noise and signal and a corresponding output of noise and signal results from the loudspeaker.

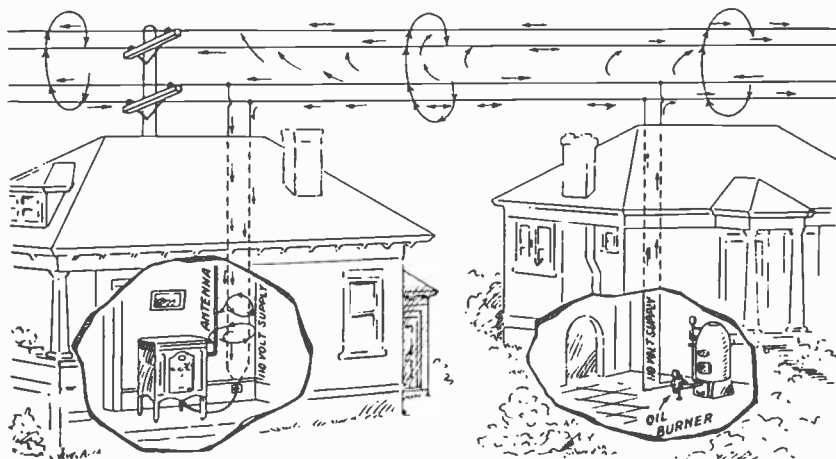

Fig. 6 Diagram showing inductive transfer of interference from the input wiring of an oil burner to the antenna system of a receiver in a neighboring building. (Courtesy Tobe Deutschmann Corp.)

Every device which uses electricity for its operation is a possible source of high frequency noise and disturbance. When a noise-producing device is operated from the same wires that supply the house with electricity, these wires will act as its aerial for radiating the noise. The noise received by direct radiation from the interfering device may be small, but the wires leading from it may carry a strong, objectionable, high frequency impulse to any set that has its aerial or lead-in close to these wires. For example, Fig. 6 shows how a neighboring oil-burner may cause interference by radiation from the power lines. This interference carried along the power lines of the home lighting circuit produces excessive noise from the receiver unless some means is used to keep it out of the aerial lead-in wire and thus out of the set and its speaker. Refrigerators, oil-burners, electric fans, trolley systems, and hundreds of other pieces of electrical equipment may send this interference over many miles

of wire, causing noise and disturbance in radio sets located far from the original source of trouble.

Noise impulses entering a house by way of the power line go to every outlet, every light, every switch, every extension, and every electrical device which is furnished with power. Fig. 7 illustrates this fact with a perspective diagram. The noise passes through the walls, the ceilings, and the floors. The radio set in its position within the house is surrounded by all of these noise-carrying wires.

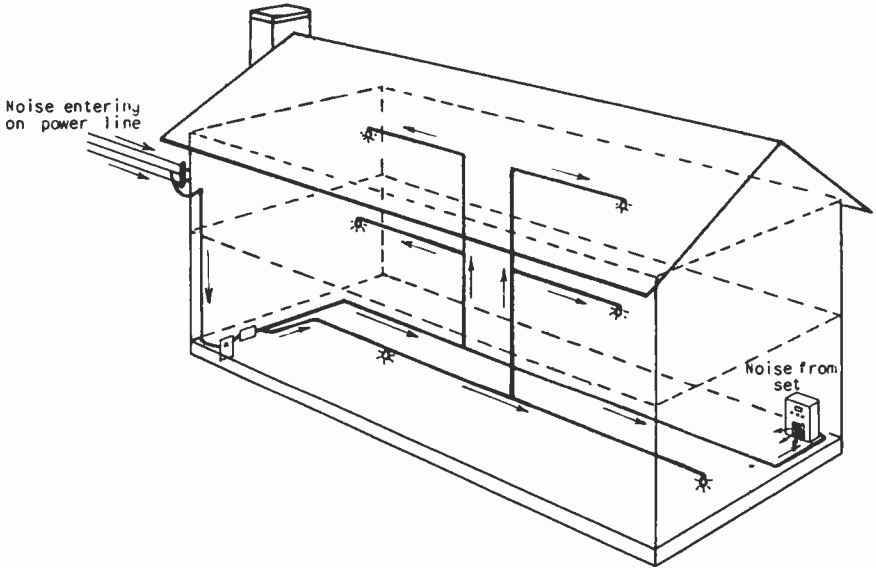

Fig.7 Showing how the network of wiring in the walls of a home distribute the interference.

Indoor aerials are generally undesirable because when they are placed within a house they will be surrounded by the noise field of the house wiring. For this reason alone, radio reception of an indoor aerial will be inferior to that possible with the outdoor type. In addition, the house wiring which surrounds the indoor aerial will partially shield it from radio signals. Placing an indoor aerial lower in the building will increase the noise pickup and decrease the signal pickup. But, some people still believe the basement to be a good location. The only location for an indoor aerial is in the attic, and then only when no light wires are within 10 to 20 feet.

At this point we would like to condemn the so-called "plug-in" antennas or "aerial eliminators". These units use the power supply wires of the house for an antenna, and as a result they are directly connected to the main source of interference in the

home. In addition, if not correctly and carefully designed and installed, they form a dangerous fire hazard.

The usual type of outdoor aerial consists of a suspended wire or group of wires connected to the set by a single wire called the "lead-in". This single wire lead-in is just as sensitive to high frequency signals as the aerial itself. Since the lead-in must come into the house and into the network of noise-carrying wires, the ordinary lead-in cannot arrive at the antenna post of the set without having picked up some of these noise impulses. Whether the lead-in goes in through the basement or around the base board, the interference will get to it.

The ordinary lead-in is a high impedance wire carrying high frequency radio signals from the aerial to the set. This type of line is subject to a high loss due to capacity effect with grounded objects. The larger the capacity effect, the higher the losses will be. Some "noise-eliminating" aerials make use of a securely grounded shield placed around the lead-in. This is satisfactory if the shielded wire is especially designed to have a low capacity but still it is likely to cause all except the strongest signals to be lost entirely. A shielded lead-in system does not generally give complete customer satisfaction.

Many customers attempt to get by with a makeshift or otherwise inefficient antenna system. The noise pickup of a poor aerial generally exceeds the signal pickup, particularly within the normal receiving range of the set. The best possible aerial, important as it is for local reception, becomes an absolute necessity for receiving long distance stations.

An ordinary elevated aerial wire does not pick up a great deal of noise itself, but, as a general rule, the lead-in wire going down the side of the house picks up a great amount of noise, and, as a result, the total amount of noise entering the set is relatively high compared to the signal level. If an attempt is made to shield the lead-in wire, a considerable portion of the original signal picked up in the antenna is likely to be lost.

The obvious solution to this problem is to locate the aerial wire itself far away from the noise field, then conduct the broadcast signal to the set with no appreciable loss and, at the same time, prevent the pickup of noise signals as the lead-in passes through the interference area. Many so-called "noise reducing" antenna systems have been devised and are available on the commercial market. These antenna systems function efficiently for the reception of radio signals from the commercial broadcast stations, and also throughout the short wave bands.

5. NOISE-REDUCING ANTENNAS. The recently developed, all-wave noise reducing antennas are easily installed and make possible the maximum pickup of radio signal energy with a minimum of noise and interference. The elimination of this noise has been made possible by changing the high impedance aerial and ground wires of the ordinary set to a low impedance twisted-pair line especially designed to cancel out all noise pick-up. Fig. 3 illustrates how a twisted pair lead-in eliminates the noise. The twist on the

cable greatly reduces its own external magnetic field, and also cuts down the ability of the line to pick up noise. Any noise signal that is induced in either of the two twisted wires will be equal to the noise signal induced in the other. Since they are closely twisted and are in the same relative position with respect to the field of noise, upon arriving at the set transformer, the two equal noise impulses are opposed and thus neutralize each other.

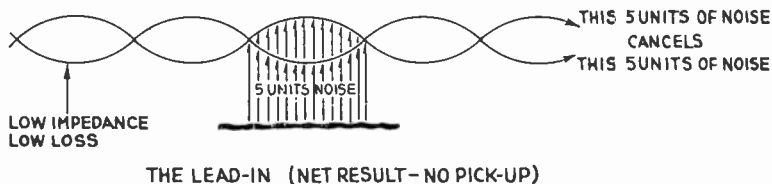

Fig. 8 How a transposed or twisted lead-in wire eliminates noise.

The efficiency of transferring radio signals over a line may be increased by reducing capacity and inductance losses. Since capacity may be used to overcome the effect of inductance, the two conductors of the transposed lead-in are twisted in such a way as to make the capacity between the lines equal to the inductance. This, of course, requires a specially designed line; an ordinary twisted lamp cord does not fulfill the necessary qualifications. Further losses are prevented by a low-voltage, low-impedance character of the line. The net result of the noise reducing combination is to produce at the terminals of the set the same clear, undistorted signals that are picked up by the aerial itself without the introduction of noise or loss of signal.

The coupling devices employed to match impedances and to transfer signal energy to and from the transmission lines are called the antenna and set transformers respectively. The antenna transformer is located near or suspended on the flat top portion of the aerial itself. It concentrates the energy received by the antenna and feeds it to the transmission line at low impedance. The parts used in this transformer are insulated to withstand the continuous application of extremely high voltages, such as 1000 volts, to prevent a possible breakdown from static surges. The whole unit is securely sealed against moisture and protected from the effects of the weather.

The set transformer is designed to deliver to the set the exact signal as received at the antenna, reversing the impedance-changing process which took place in the antenna transformer. On older model sets, the transformer may be mounted externally and a switch may be provided for correctly matching the line impedance in the short wave and broadcast bands. Late model receivers usually have these transformers incorporated in the receiver and the necessary impedance matching is automatically taken care of by the waveband switch. Usually a second antenna binding post is provided for use where a noise reducing antenna is not re-

quired. Where a noise reducing antenna is used, it is always necessary to use the antenna specified by the receiver manufacturer. This is necessary due to the wide variation in transmission line impedances between the antennas of different manufacturers.

In transmitting high frequency radio signals, it is important to have the aerial wire itself correctly tuned to the frequency of the signal being transmitted. When used for receiving, maximum efficiency will also result when the aerial is tuned to the frequency of the desired station. If only one station is desired, maximum efficiency can be obtained from a single flat top aerial of the proper length. But, since practically every customer demands reception of a large number of stations having varied power and frequency, the modern aerial must work efficiently on every band of the modern all-wave receiver. In most all-wave noise reducing antenna systems, the proper response is provided by the use of different sections of the flat top, each broadly tuned to a definite frequency. Some of these resonant points are located in the broadcast band and some in the short wave band. By combination of aerial, transformer, and lead-in, many other resonant points are provided. These are evenly spaced along the response curves, making it practically a straight line over the entire tuneable range of the receiver. In this way, the flat top portion of the aerial is made to respond efficiently to all signals on the short wave or standard broadcast bands. For example, the antenna shown in Fig. 9 consists of twelve separate wires (6 doublets) and tunes efficiently over the entire frequency range from 140 kc. to 23000 kc. The overall length of the antenna is about 37 feet.

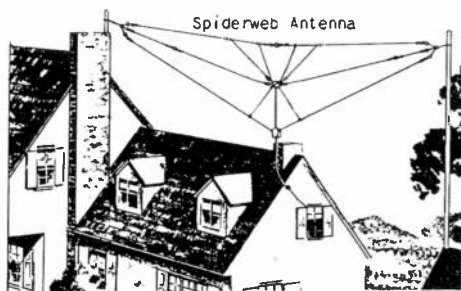

Fig. 9 An erected R.C.A. Spiderweb antenna.

In order that we may more fully understand the principles and functioning of the all-wave antenna systems, let us select a typical antenna which is more or less basic in its operation. In this system the signals are collected by an antenna and are brought down to the receiver clear and undistorted through a transmission line. The signals are free from noise pickup due to stray electrical disturbances. Through the proper design of the circuit and with careful supervision in production, it is possible, although not usually necessary, to have the antenna several hundred feet from the receiver.

As one transformer cannot efficiently cover the standard broadcast as well as the short wave bands, two separate transformers are used, both at the antenna and in the receiver. For ease in explaining this system, we will first consider the broadcast transformer as shown in Fig. 10, after which we will consider the short wave transformer as shown in Fig. 11, and, finally, the combination of the two as shown in Fig. 12.

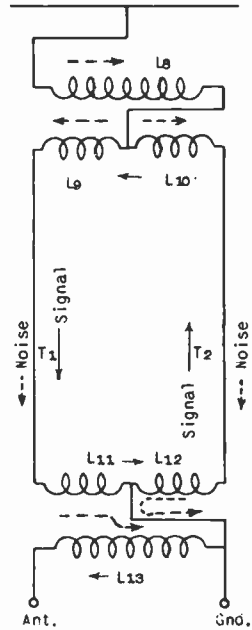

Fig. 10 Standard broadcast noise reducing antenna system designed by TACO.

The voltage picked up by the antenna proper forces a current through the high inductance primary,  $L_8$ , into the center tap between  $L_9$  and  $L_{10}$ , through the transmission line  $T_1$ - $T_2$ , and through the center tap between  $L_{11}$  and  $L_{12}$  to ground. The voltages produced across  $L_{11}$  and  $L_{12}$  by this current flow (indicated by dotted arrows in Fig. 10) will not generate a voltage in  $L_{13}$  due to the fact that these currents enter  $L_{11}$  and  $L_{12}$  from opposite ends and leave at the center tap, which in effect cancels their magnetic fields. However, when this same antenna current is flowing through the coil  $L_8$ , the magnetic field around  $L_8$  induces a voltage in the coils  $L_9$  and  $L_{10}$ , as indicated by the solid arrow. These magnetically induced voltages in  $L_9$  and  $L_{10}$  cause a current to circulate through the antenna and set transformers,  $L_9$ ,  $L_{10}$ ,  $L_{11}$  and  $L_{12}$ , and through the transmission line. These currents, therefore, do not cancel, but rather pass into  $L_{11}$  and  $L_{12}$  at one end and leave at the other; thus inducing a voltage across the secondary  $L_{13}$ , which is the radio signal for the receiver.

It is obvious that with the transmission line having its two conductors closely spaced, a noise or interference signal will strike both conductors with the same polarity and, therefore, the noise will react in the transmission line circuit the same as the directly-coupled current described above. It will pass through the primary L11-L12 to ground from opposite sides of the transmission line and will not induce any voltage in the secondary L13.

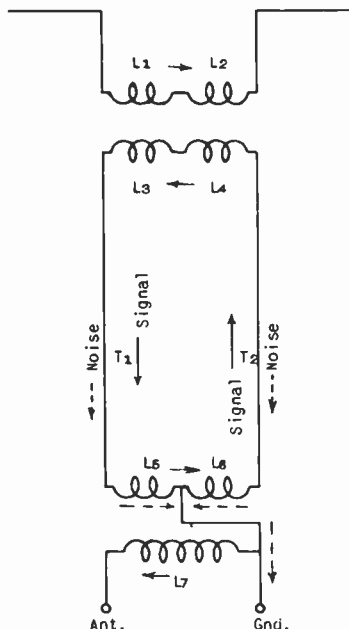

Fig. 11 TACO short wave noise reducing antenna system.

As the voltage between the antenna and ground terminals of L13 is the driving force for the receiver, it is obvious that the noises are effectively separated and eliminated from the desired signal.

Fig. 11 shows a di-pole antenna which will induce voltages of opposite direction in the transmission line by virtue of the difference in phase of the wave fronts at the ends of the doublet. If transformers of suitable construction and ratio are introduced into both ends of the transmission line, the signal transfer will be improved through proper matching of the component parts. Where useful signal currents (indicated by solid arrows) and noise impulses (indicated by dotted arrows) are mixed in the transmission line, they will be separated as described before; the noise signals leave through the center tap between L5 and L6 without affecting the performance of the radio set.

The two sections of the antenna system as described above will operate efficiently in their particular bands. They may be readily interconnected by suitable switching arrangement, but



from a practical standpoint it is necessary to have such switching fully automatic as it is impractical to perform any manual switching in the antenna circuit. The combination circuit is shown in Fig. 12. It is based on the fact that the impedance of an inductance increases with increasing frequency, whereas the impedance of a capacity decreases with the frequency. Consequently, a small inductance will effectively block a high frequency signal, whereas a small capacity will prevent a standard broadcast signal from passing. By suitable design of the transformers, the performance of the two bands will not interfere with each other or with the overall performance.

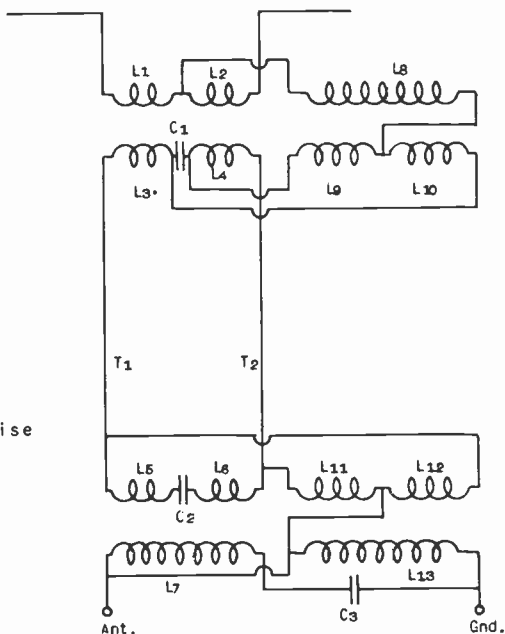

Fig. 12 TACO all-wave noise reducing antenna system.

Short wave signals are transferred from L1-L2 into L3-L4. The inductance of L8 prevents the high frequency signals from going into the broadcast transformer. Condenser C1 completes the circuit L3-L4. The short wave signals now pass through one conductor of the transmission line, through primary windings L5-L6, condenser C2, and back through the transmission line to complete the circuit. From the above, it follows that the driving signal voltage for the receiver will be across L7 between the antenna and ground terminals.

The broadcast signals enter the broadcast primary L8 through L1 and L2 generating primary and secondary voltages as described previously. The condensers C1 and C2 have a small enough capacity to prevent L3-L4 and L5-L6 from short-circuiting the broad-

cast primary. Therefore, the circuit will be completed through the transmission line and L11-L12 inducing the desired signals in L13. As the impedance of L7 is small, a capacity C3 is in series with it to prevent L7 from short-circuiting the antenna and ground terminals for standard broadcast signals.

For maximum signal transfer, it is necessary that the antenna transformer produce a proper match between the antenna and transmission line and that the set coupler match the transmission line to the input circuit of the radio receiver. The antenna systems described above are designed for sets with approximately 400 ohms input on the short wave band and approximately 2500 ohms input on the standard broadcast band.

From the description of this system, it is apparent that the ground lead must be as short as possible; otherwise, its resistance will cause a drop of potential due to both signal and noise currents and it will be added in series with the secondary voltages, thereby re-introducing the noise voltage into the set and tending to impair the noise reducing qualities of the system. For this reason, the antenna and ground leads from the transformer to the binding posts on the set should, for best results, never be extended beyond five inches. Connection of the ground leads to an actual ground may help the noise conditions in some installations, the results depending upon the amount of electrical currents flowing through the ground used. The only way to determine the advisability of this connection is by actual trial.

It is permissible to add to or subtract from the length of the transmission line furnished by the factory in some cases without changing the effect of the system as a whole. Before making such a change, however, the service engineer should carefully study the instructions for the particular antenna system in use. The possibility of lengthening the transmission line is very important as it allows the placing of the antenna at a point far removed from the receiver itself to a point where the noise level is comparatively low.

6. ANTENNA INSTALLATION. We have been discussing the noise reducing antenna from the standpoint of design. Now let us examine this antenna from the standpoint of installation and study definite points which should be followed.

1. The aerial proper should be erected as high as possible and away from known sources of noise.
2. The aerial proper should be erected clear of all buildings which may shield it from any broadcast signal.
3. The transmission line between antenna and receiver should be anchored securely to prevent shorts and opens.
4. The set coupling transformer between transmission line and receiver should be mounted as close to the receiver as possible. The leads furnished with this coupling transformer should not be lengthened for any reason.

Fig. 13 shows how a private home can be economically and neatly wired for radio outlets in each room where radio reception

may be desired. Radio outlets may be provided in any room, porch, basement, or other part of the house offering convenient antenna and ground connections for radio sets. The twisted leads connect to the transmission line. The aerial for such a system may be installed in the attic of the house, or, better, it can be strung

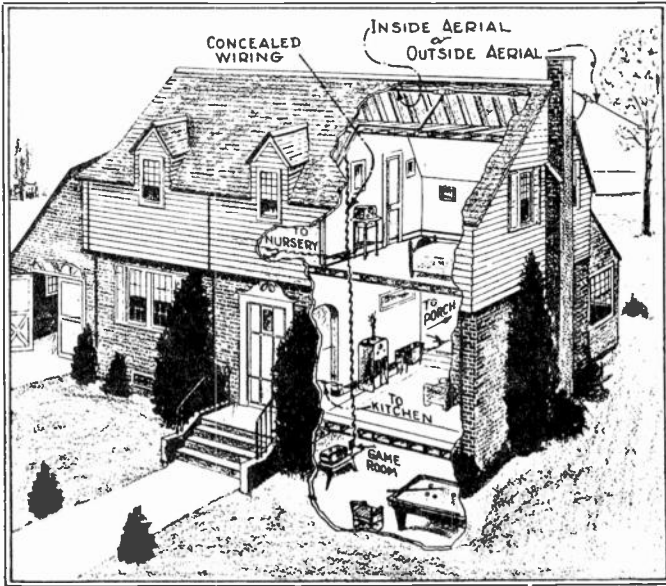

Fig. 13 Showing how numerous outlets may be provided in a home.

from the house to the garage or to a high tree. If it is anchored to a tree, use a spring between the aerial and support to compensate for the tree swaying in the wind, or use a pulley arrangement as shown in Fig. 14. The location of the aerial in the attic is feasible only when the house is located in a typical residential section of the better kind and there is a reasonable spacing between property. If the roofing consists of metal, this type of installation does not work satisfactorily due to the roof's shielding effect. If the house is closely surrounded by taller buildings, the aerial must be strung outside and as high as possible. The direction of the aerial is also important. Pickup will be greatest from the direction at right angles from the length of the flat top wire. This means that power lines run parallel with the aerial will transfer more noise to the aerial than wires run at right angles. It also means that interference under or over the aerial may have a strong effect upon the flat top. This directional effect may be used to advantage where the interference is coming from a definite source by turning the aerial so that minimum pickup of the noise will result. If possible, the aerial should always be placed completely outside of the interference field.

The poles that are used to support the aerial may be of metal or wood. Metal poles are generally desirable because of their durability and strength. These advantages may outweigh the disadvantages of weight and conductivity if certain precautions are observed. An awning eye placed at the top of the pole will prevent rain from entering and rusting it from the inside. This will also be convenient for fastening all wires. As shown in Fig. 15, the base of the pole should rest upon a block of wood about one foot square, and at least one inch thick, preferably two. A hole drilled part way into the center of the wood will provide protection against slipping and make flanges unnecessary. Another point to observe is the placing of the wooden base on the roof. A flat block of this type will allow water to accumulate under it without providing proper ventilation. This constant presence of moisture will in time not only rot the block, but more serious, it will cause decay of this portion of the roof. Strips of ordinary builder's lath nailed to the underside of the block and spaced one inch or so apart will effectively prevent the collection of excessive moisture. Finally, metal poles should be grounded to eliminate the lightning hazard. Connection may be made to any ground found upon the roof.

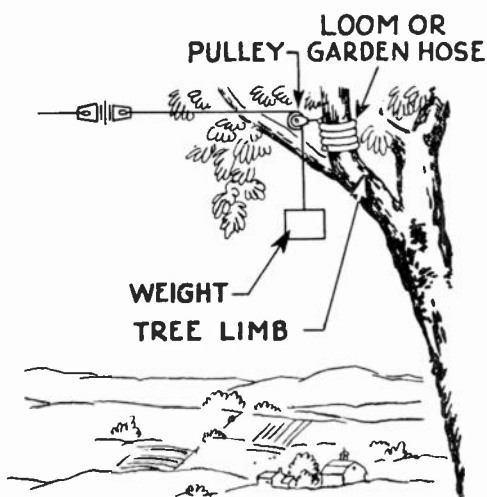

Fig. 14 illustrating how an aerial wire should be fastened to a tree.

If wooden poles are used, the type of wood selected is very important. Pine and similar soft woods are not good, but hickory will be found excellently suited for this purpose. Be sure the pole is of sufficient size in cross-section so that it will not sag and do not use nails driven directly into the wood for fastening any of the wiring. Nails will rust shortly and guy wires will break away. Always wrap a guy wire completely around the pole two or three times to gain an effective hold and then a few

nails may be used to prevent slipping. The support for a wooden pole may be the same as that recommended for metal.

All guy wires should be broken up by insulators so that no portion of them is longer than 8 feet. Any support wire over 8 feet long will require at least one such insulator. This is to

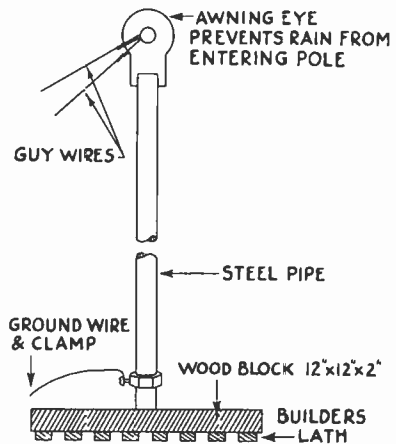

Fig. 15 Metal pole for supporting the aerial wire.

prevent the guy wire from acting as an aerial at a frequency close to that which is being used. All other leads come into the same classification and should be broken up by insulators in the same manner.

The lightning arrester should be placed at the point of entry into the building. The center post of the arrester should be connected to a good ground outside of the building, as shown in Fig. 16. This is required by the Underwriter's laws in most

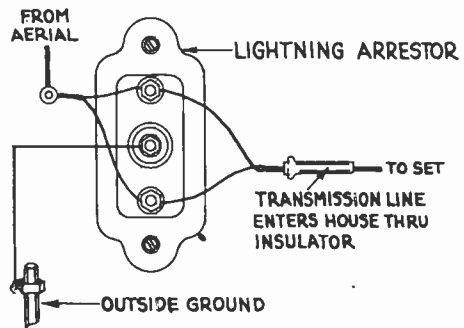

Fig. 16 Showing the connections of a lightning arrester when a transmission line is used.

states. Carrying the lead-in through the wall of the building by means of a porcelain tube provides for the best appearance. Magnetic fields of other wiring of any kind do not have to be taken into consideration when locating this wiring if the transmission line is of the twisted or transposed type. However, precaution

should be observed to prevent short circuits occurring or wear cutting through the wire. Ordinary insulated staples may be used to fasten it down to a rafter or to the finished woodwork. These staples are inexpensive and should be used freely to provide a neat installation.

Locating a flat top aerial on a small house has always been quite a problem, since the requirements of most of the all-wave aerials are from 34 to 60 feet. On those homes that do not provide a straight path of this length, it may be necessary to devise unusual methods of support. One way to secure the necessary length for the flat top is to provide a large difference between the height of the two poles used. This is impractical in cases where the tall pole cannot be well supported. Poles may be mounted directly at the edge of the roof if struts are used to support the guy wires, as shown in Fig. 17.

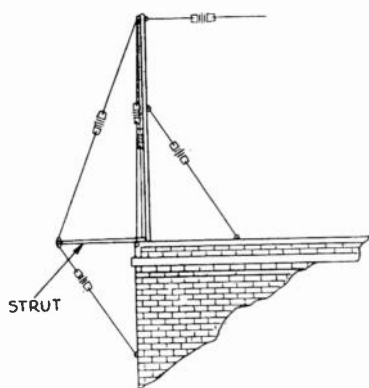

Fig. 17 Mounting an aerial support on the corner of a building.

Installation of a good noise reducing aerial on the roof of an apartment house is also quite a problem. This is, in part, due to the complete disregard which some people have for the property of others. In cases of this kind, it is extremely difficult for the service engineer to make a good installation without altering the placement of the aerials used by the other tenants in the apartment. This generally requires considerable time and so is expensive from the serviceman's standpoint. When conditions such as this are encountered, it is always best to attempt to sell the apartment owner a Master Antenna System for serving each apartment in the building. Unless some arrangement can be made with the apartment owner or the other tenants in the building, it is virtually impossible to make an efficient installation for your customer.

On most apartment houses, a large space is available for the placement of aerials radially around a pole somewhere near the center of the roof. The other ends of these aerials may be suspended from projections above the roof, sufficiently high for the purpose, or by means of poles. In any case, the number of

aerials that can be placed around the circle will depend on the distance that the roof allows them to be placed from the central pole, keeping in mind the fact that each will have a tendency to shield partially those next to it. Parts A and B in Fig. 18 illustrate how the efficiency, as well as the appearance, of the various aerials on top of an apartment house may be improved by this method.

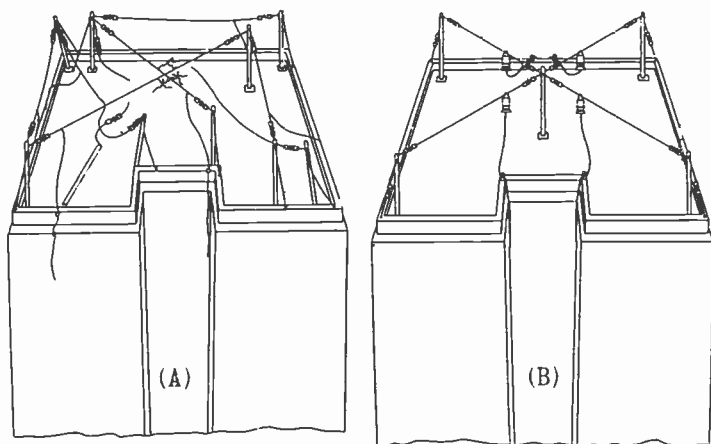

Fig. 18 Both the performance and appearance are improved by arranging the several wires as shown at B.

Should the radial arrangement be impractical, a series of antennas placed side by side, allowing 10 feet between each, would answer the purpose. It must be remembered that ordinary types of aerials placed too close to an all-wave noise reducing aerial tend to induce considerable interference into the noise-reducing installation, thus seriously impairing its efficiency in noise reduction.

In a multiple antenna installation on an apartment house, extreme care should be used in dropping the transmission lines down to the various apartments. When running down the side walls of the building, the line should be anchored at least every three floors. The most satisfactory and least expensive method is to use knobs with the wire fastened according to standard practice as shown in Fig. 19. The length of the transmission line is not critical, but for practical reasons, it is not advisable for it to exceed 250 feet.

The number of individual couplers that may be connected to any one transmission line down the side of a building depends on the design of the entire system. This information, of course, is supplied by the manufacturer and may be obtained upon request when contemplating an installation of this kind.

On newly erected buildings, the transmission lines leading from the aerial on the roof may be entirely concealed within the walls and the specifications for the complete installation are

practically the same as those followed by the electrical contractor in his other wiring and, likewise, in accordance with the Fire Underwriter's Code.

7. MAN-MADE INTERFERENCE. In the first part of this lesson we mentioned that man-made interference was a source of continual trouble to the serviceman. In recent years, due to local legislation and the education of the manufacturers of electrical apparatus, great strides have been made toward the elimination of this trouble. However, much remains to be done along this line, so we feel that a thorough knowledge of how to eliminate man-made interference is essential to the modern service engineer.

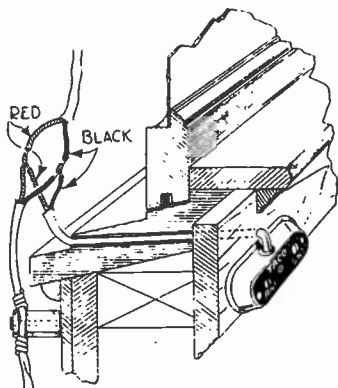

Fig. 19 Illustrating how to support the transmission line and how to pass through the wall to the ANTI-GND outlet.

In many cases, even with a noise reducing antenna, noise interference is sufficiently strong to reach the flat top of the antenna and will be reproduced in the receiver. Also as previously stated, the signal may come through the power lines or may be introduced through an improperly shielded receiver. Of course, the most effective way of combating such interference is to eliminate it at its source.

When electrical equipment of any sort creates a spark or arc during its operation, an RF interference wave is generated simultaneously. The magnitude of this noise or interference wave depends largely on the size of the created spark. In most electrical apparatus the spark which occurs during operation is an undesirable aftermath and constitutes a waste of power. In this classification falls equipment such as electric motors, sign flashers, power line transformers, high tension wiring, electric light sockets, trolley lines, etc. In other types of equipment the generated spark is a normal function of that equipment and hence must be tolerated as an uncorrectable evil. Equipment falling in this classification include X-Ray apparatus, diathermy equipment, violet ray machines, automobile motors, electric welding, etc.

The spark itself, as produced by the electrical device, does not cause serious interference; it is simply creative of the RF



oscillations and energy which, to cause interference with radio reception, must have some means of radiation and conduction to convey the energy to the radio receiver. In the cases of the machines and devices mentioned, the electrical wires leading to and from the equipment, as well as the mass of metal employed in its construction, serve as excellent radiators of the spark energy. That energy which is sent through the conducting power lines to the radio receiver can sometimes be eliminated entirely by the use of a line filter at the radio receiver, as was illustrated in Fig. 2. Filter circuits are not always effective in removing noise from the power line, but at least they should be connected as the first trial toward eliminating the interfering noise.

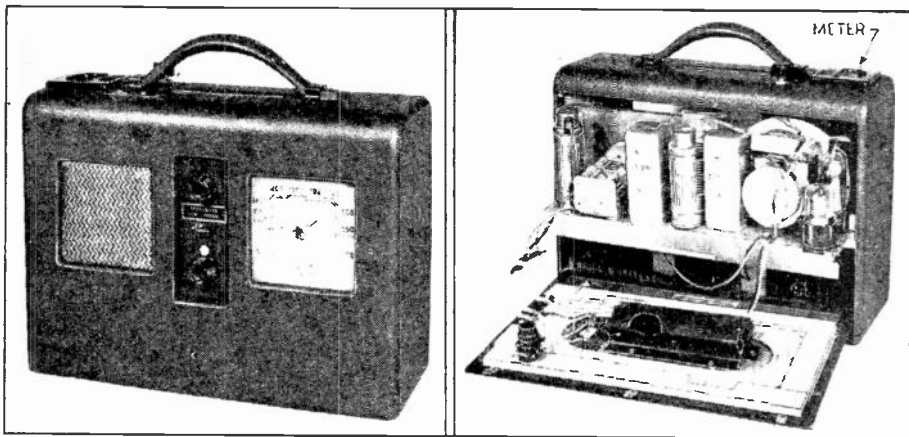

Fig. 20 An interference locator.

There are so many potential factors which may cause noise and interference that the service engineer is generally confronted with a serious problem in attempting to determine the exact origin of the disturbance. In some cases, the experienced man can recognize the characteristic noise caused by some devices and place it in a category of equipment which is most likely to cause that type of interference. These characteristic sounds will be enumerated in later paragraphs. If, however, it is not possible to arrive at a definite conclusion as to the source of interference by merely listening to the sound from the speaker, then it becomes necessary for the service engineer to locate the actual source, using whatever means or equipment he may have at his disposal. A valuable piece of equipment for this purpose is a portable instrument which will respond to the same impulses that interfere with radio reception. These are known as "interference locators". A photograph of this instrument is shown in Fig. 20. To be satisfactory for locating radio interference, an interference locator must be light enough so that it may easily be carried by one man. It must be entirely self contained and it must be sufficiently sensitive to respond to those weak, in-

terfering impulses which affect radio reception. Its sensitivity must be obtained without sacrificing selectivity and without using a ground or any connection to a power line. It must be rugged enough to withstand comparatively rough treatment and must be provided with meters so that the intensity of interference may be measured.

The "noise locator" or interference locator should be a highly sensitive superheterodyne. Most commercial units such as that illustrated in Fig. 20 use both loop and rod antennas. The loop is used for directional work while the rod antenna is used for intensity measurements. Of course the unit must be self-contained; that is, it must obtain its power supply from batteries. As a rule those noises that cause radio interference are present on all bands, so, for that reason, commercial interference locators usually have only one frequency range from 500 to 1600 kc.

Gain controls and an output meter make it possible to make comparative interference measurements in the search for the source. A loudspeaker or headphones may be used to ascertain the nature of the interference or to check the intensity of the signal.

In case the service engineer finds it is not possible to equip himself with such an instrument, when called upon a job where it is necessary to find the source of interference, he should, by all means, be fair with the customer and not charge an exorbitant price for his services if they terminate without locating and correcting the trouble. It is quite true that a large percentage of noise and interference in radio reception is due to bad tubes, faulty parts, or wiring in the chassis, etc., in which case the service engineer should be capable of locating and correcting the trouble by the use of his ordinary instruments. However, if he knows that the source of interference is external to the radio chassis and he does not have the means with which to locate and correct that trouble, then he should not falsify his statements or the result of his work to the customer because such business practices ultimately result in a bad reputation. If he cannot correct the trouble, he should tell the customer, then make whatever suggestions he might have in a truthful and straightforward manner. For example, he might suggest that the customer contact the local power company to see if they have facilities for tracing down interference that is beyond the scope of his line of work. Nearly all large power companies have these facilities available and are only too glad to cooperate with the customer or the service engineer in locating interference caused by their power lines. In most instances, the location and correction of the trouble will be beneficial not only to the customer but also to the power company because it is a result of deficiency in their apparatus. If they are able to locate and correct such troubles before a complete breakdown occurs, it means that they are more efficiently supplying the community with uninterrupted power service. Some power companies maintain a separate depart-

ment strictly for the purpose of investigating radio interference and their service is always at your disposal. Cooperation with the local power company and the customer will be found to bring far better ultimate results than the slight profit that might be made from deceiving the customer into purchasing a new set of tubes, a new power transformer, etc., all of which are ineffective and unsatisfactory for correcting his original complaint.

8. SOURCES OF INTERFERENCE. Assuming that the service engineer has made sufficient tests to conclude definitely that the origin of the interference is some offending electrical device, his next step would be to ascertain whether or not the offending device is located in the customer's home or is being caused by faulty equipment or wiring from the outside. To make this test, a line filter may first be connected at the radio receiver, then at the main service switch controlling the power into the house. On the older style service boxes, it is possible to open the main switch and connect the line filter directly across the switch terminals. However, on the later service boxes being installed by most power companies, this switch is not available and it will be necessary to have a representative from the local power company open the box for you. If the noise in the radio receiver still persists when the line filter is inserted at the main service switch, then the trouble can generally be assumed to originate within the customer's home. If the noise stops with the filter at the service switch, evidently the power company's equipment or a neighboring home is the source of interference. If the service engineer does not have an interference locator available, he should then call upon the proper authorities of the local power company for assistance in finding the trouble.

If, on the other hand, the noise source is found to be in the customer's home, he must proceed to inspect carefully all of the electrical equipment in use until the offending device is found. The correction of the trouble then depends upon the nature of the source. Various remedies will be described in subsequent paragraphs.

Most types of radio interference have a characteristic sound. If you listen carefully to the noise from the loudspeaker, you may be able to determine which of the following classes most accurately describes the type of interference. Then, by noting the kinds of electrical apparatus which are most likely to cause such a noise, you can hunt for a similar piece of electrical equipment in the customer's home or in the immediate neighborhood.

1. *Whirring, Crackling, Buzzing, Humming, Droning and Whining.* Sounds like these generally indicate radio interference which is caused by an electrical motor. Sometimes when the motor starts and stops, the sound will start low and rise in pitch until the motor reaches its full speed when the whine will remain at a certain steady pitch, usually rather high. This is especially true of commutator type motors. Repulsion-starting, induction-running motors may have a sputtering, crackling, buzzing or hum-

ming sound. When such sounds are heard, hunt for one of the following:

Adding Machines	Floor Polishers
Automatic Towels	Generators
Barber's Clippers	Hair Dryers
Beauty Parlor Devices	Humidifiers
Billing Machines	Message Machines
Cash Registers	Motor Brushes
Dental Engines	Motor Generator Sets
Dish Washers	Portable Electric Drills
Dough Mixers	Printing Presses
Drink Mixers	Sewing Machines
Electric Addressing Machines	Shoe Driers
Electric Computators	Small Blowers
Electric Elevators	Telephone Magnetos
Electric Refrigerators	Toy Electric Trains
Electric Vibrators	Vacuum Cleaners
Fans	Valve Grinders
Farm Lighting Plants	Washing Machines

2. *Whistles and Squeals.* Sounds of this sort generally indicate radio interference which is being caused by oscillation within the set itself. Often the whistles or squeals start high, dip to a low note, and mount again to a high pitched squeal which may vanish entirely or remain at a steady high-pitched whistle. Heterodyning broadcast stations have a sort of bubbling whistle and can be recognized by the fact that they usually occur at the same spot on the dial. The only effective method of eliminating the 10 kc. heterodyne whistle is to install a 10 kc. filter in the audio system of the receiver. Some of the older radio sets which tuned by using the squeal produced by the signal caused a similar squealing sound to be heard by all radio sets in the vicinity. The addition of a stage of RF amplification ahead of the oscillating detector will generally stop this. Superheterodyne receivers frequently develop a defective part in the oscillator circuit which will cause radiation of a steady RF from the receiving antenna and cause interference in neighboring receivers. Excessive regeneration and oscillation are the common causes for sustained whistles and squeals in radio sets and the service engineer should be sufficiently acquainted with the theory regarding these sources to make the necessary corrections.

3. *Rattles, Buzzes, Machine-Gun Fire.* Sounds of this sort generally indicate radio interference which is being caused by telephone dialing, buzzers or door-bells. It is generally not steady, but starts and stops. Short rattling sounds like machine gun fire, varying slightly in length, indicate telephone dialing. Look for the following sources:

Annunciators	Doorbells
Automobile Ignition Systems	Elevator Controls
Buzzers	Sewing Machines
Dental Laboratory Motors	Switchboards
Dial Telephones	Vibrating Rectifiers

4. *Violent Heavy Buzzing or Rushing Sounds.* Sounds of this sort generally indicate radio interference which is being caused by high-frequency apparatus. Such noises will usually be heard over a large area or a whole town, and often so loud that they drown out the radio program completely. Look for the following sources:

Air Purifiers	Insulation Testers in Cable Plants
Battery Chargers	Ozone Devices
Diathermy Machines	Rotary Spark Gap in Experimental Labs.
Doctor's Apparatus	Steady Oil-Burner Spark Ignition
Dust Precipitators	
Flour Bleaching Machinery	
High-frequency Apparatus	
	Violet Ray
	X-Ray

5. *Crackling, Sputtering, Snapping, Short Buzzes or Scraping.* These various sounds from a loudspeaker generally indicate radio interference which is being caused by one or more loose connections. Sometimes the sounds are especially noticeable when the room is jarred or shaken by footsteps, streetcars or traffic. Look for the following sources:

- Bad Connections
- Burrs on Plates of Variable Condensers
- Corroded or Loose Connections in Radio Sets
- Defective Light Sockets
- Elevator Controls
- High Tension Lines
- Loose Connections in Floor Lamps, Appliance Cords, Broken Heating Elements, etc.
- Power Lines Grounded on Branches
- Street Cars
- Trickle Charger
- Wet Insulators

6. *Clicking.* Clicking sounds generally indicate radio interference which is caused by some sort of make and break connections such as a thermostat, especially if it comes at fairly regular intervals. Look for the following sources:

Defective resistors in power packs	Ovens
Elevator controls	Percolators
Flashing signs	Shaving Mug Heaters
Heaters	Sign flashers
Heating pads	Soldering irons
Incubators	Telegraph relays
Irons	Traffic signals
Mercury arc rectifiers	Electric typewriters

7. *Heavy Violent Buzzing, Usually Short.* This generally indicates radio interference that is being caused by arcing across a gap. This may occur as a short noise or a steady one. Look for the following sources:

Arc light	Moving picture machines
Automobile ignition	Telephone interruptor
Breaks in third rails	Street car switches
Electric car switches	Street lights
Electric cigar lighters	Toy electric trains
Electric elevators	

8. *Steady Humming.* Sounds of this sort generally indicate radio interference that is being caused by improperly filtered alternating current. Such humming is often due to the set itself. Look for the following causes:

- Dynamic speakers improperly filtered
- Faulty construction of set power supply
- Filter condenser open or shorted
- Poor ground on set
- Improper wiring
- Poor tubes
- Wiring parallel with power line

9. **USE OF FILTERS AT THE NOISE SOURCE.** If it is economically practical and possible to do so, the interference should be eliminated directly at its source. This requires the use of a properly designed filter, which generally consists of a single condenser, two condensers, or an inductance-condenser combination. A filter, if properly designed, will at least greatly minimize the radiation of the interference through the power line, even though it may not remove the noise entirely. To secure the best results from any filter, it should be connected as close to the device as possible.

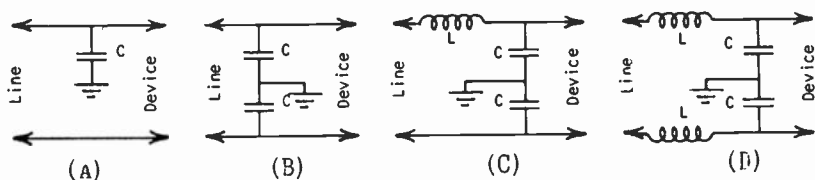

Fig. 21 Four filter arrangements which may be used for minimizing the feeding of interference into the power line.

Several types of filters are illustrated in Fig. 21. The simplest type is shown at A, consisting of a single condenser which is connected between one side of the line and the frame of the device generating the spark. For example, if the noise source is a motor, the condenser  $C$  would be connected from one side of the power line to the frame of the motor. It should be located as closely as possible to the motor brush inside the frame. Its size depends upon the type of motor, generally from .1 to 1.0 mfd. is the average value for most household appliances.

A single condenser is effective only on those devices which draw a very small current and whose interference is not of extreme

magnitude. For larger motors, two condensers should be connected, one from each side of the power line to ground as illustrated in B of Fig. 21. As before, the junction of the two condensers is connected to the frame of the motor for ground.

When the interference is rather severe and is not minimized sufficiently with condensers alone, choke coils must also be inserted in the power line. These coils must be connected on the line side of the condensers, as illustrated at both C and D in Fig. 21. It is essential that they be connected on the line side so as to provide a low impedance path to ground through the condensers for the high frequency interference signal, but still prevent the noise signals from entering the line due to their high inductive reactance. These coils may be of the RF or AF type, depending upon the type of noise being suppressed, and they must also be wound with wire sufficiently large to carry the full current drawn by the device generating the noise. Ordinarily inductance values of about 2 millihenries are sufficient for choking back the high frequency noise signals generated by the average size motor. Fig. 22 illustrates the operation of an inductive-capacity filter.

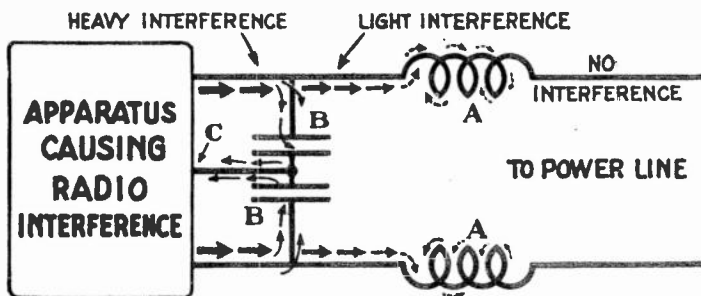

Fig. 22 How a line filter operates. (Courtesy Tobe Deutschmann Corp.)

Whereas it is possible for the service engineer to construct his own filters for electrical devices, one should take into consideration that interference elimination has been studied so thoroughly by various manufacturers that they are in a far better position to provide the correct type of filter for various applications. These manufacturers are constantly experimenting and improving their filters, their objective being to provide the service engineer with a product that is highly efficient in suppressing all types of noise. For this reason it is advisable in all cases to inspect the manufacturer's equipment and select the proper filter from his line of products. You will find that the line of filters is surprisingly complete, and that there are specially designed units available for the suppression of nearly every type of common noise source.

In all states, the Fire Underwriter's Code requires that all electrical equipment meet with the approval of the board. Home

made filters are generally not accepted by the Underwriter inspectors, whereas all commercial units have been approved by the proper authorities before being placed on the market. For this reason, also, it is advisable to purchase the filter units which you install from a wholesale dealer rather than attempting to construct your own, even though they appear quite simple.

At the present time, practically all devices of an electrical nature, and designed for use in the home, are equipped with interference eliminators. However, as these units may become defective, we will give in the following paragraphs some general instructions on the type of filters to be used.

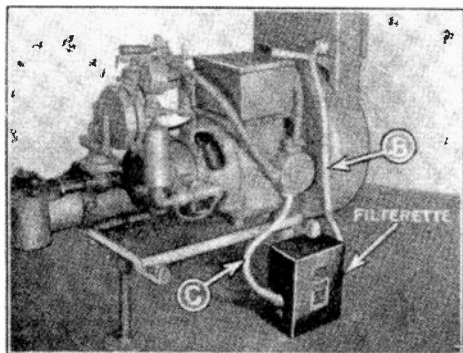

Fig. 23 Application of Tobe Filterette OB-110 to an oil burner.

#### 10. THE APPLICATION OF COMMERCIAL FILTERS. 1. Oil Burners.

Oil burners in homes and in apartment houses are a common source of radio interference. The interference may be caused by the pump or blower motor, by the ignition system or by a portion of the temperature control apparatus. The interference due to the motor is usually in the form of a crackling or a siren-like whining noise, which remains at a steady intensity during the entire period that the oil burner is in operation. This type of interference is likely to occur when the motor is operated from direct current. If the motor is operated from alternating current, the interference from the motor should not be continuous. The only type of heat regulating apparatus which consistently causes objectionable radio interference is that which employs a small motor. This is usually of the series-wound type and causes an interference which is heard as a loud roaring noise, generally lasting from 20 to 100 seconds. A capacitive filter, such as shown at B in Fig. 21, is usually satisfactory for suppressing the interference from this type of apparatus. In extreme cases, a filter of the inductive-capacitive type, such as D in Fig. 21, is required. In either case, the filter should be connected directly at the power input to the motor, and its return lead should be connected to a carefully cleaned part of the motor frame. Fig. 23 shows the application of a commercial filter to an oil burner. Notice that an armored cable must be used in the installation of this filter so as to pass the Fire Underwriters inspection.



Most commercial oil burners require individual attention as to the most effective methods of suppressing radio interference throughout their high tension ignition and wiring systems. Specific directions cannot be given which will apply to all types of burners due to the wide variance in their design. When necessary, the manufacturer of the oil burner unit may be consulted to obtain the directions. Also, by writing directly to the manufacturer of radio interference filters, you will find that they are always glad to cooperate and recommend the type of filter most applicable to the job you have at hand.

2. *Electric Refrigerators.* When AC operated electric refrigerators are in perfect electrical and mechanical condition, they do not cause radio interference, except during a few seconds when the motor is starting and while it is obtaining its running speed. The motor used with an electric refrigerator is usually of the repulsion-starting, induction-running type, employing a centrifugal switch which cuts out the starting mechanism when the motor has obtained its running speed. However, after the motor has been in operation for some time, it is likely to become a creator of radio interference. This may be remedied by a thorough overhauling of the motor. Due to the location of the motor, it is exposed to dirt and moisture and, consequently, such overhauling would have to be done frequently. For this reason, it is expedient to apply an external device for the elimination of radio interference. Refrigerators operating from direct current are likely to cause continuous interference.

If the refrigerator is operated on an AC line, a filter, as at D in Fig. 21, may be applied to suppress the radio interference. Filters should be mounted as closely as possible to the motor and the ground wire should be connected to a carefully cleaned part of the motor frame.

3. *Various Home Appliances.* As a general rule, the smaller household appliances employing series wound or universal motors may be effectively silenced by means of the capacity type filter. Larger appliances employing repulsion-induction motors will require the use of an inductive-capacity type filter. However, before applying this type of filter, carefully note the voltage and current requirements of the apparatus in order that a filter having sufficient current carrying capacity may be used.

4. *Neon Signs.* A steady burning neon sign in good condition should cause no radio interference. If a sign of this type appears to be causing interference, it should be carefully inspected for broken bushings or other defects. In many cases, an accumulation of dirt on the glass tubing of the sign will result in the passage of minute currents causing radio interference. A thorough overhauling of the sign should be all that is required to eliminate the interference. A neon sign which consists of glass tubing alone, with no metal backing, will sometimes affect nearby receivers. A mass of metal near the tubing usually tends to absorb the interference. If interference is being caused by the sign

flashing on and off, the same treatment is required as for any flashing sign. When choosing filters for application to neon signs, the measured primary current of the sign transformer must be known.

All types of sign flashers create radio interference. Some flashers are small thermostatic units mounted in the lamp or socket, and others operate from small mercury switches or employ mechanical interrupters. These all require the use of filters to suppress the interference to radio sets.

Many more of the possible sources of radio interference were enumerated in the discussion earlier in this lesson. It is unnecessary to go into complete detail as to the method of suppressing the interference created by each of these various devices. The same general rules are followed as those just outlined. The type of filter which will be most effective in reducing or eliminating the interference may vary slightly in each case. When interference from one of these miscellaneous sources is encountered, you may determine which one of the many commercial filters available will be most effective in suppressing the noise by consulting your local wholesaler or by writing directly to the filter manufacturer.

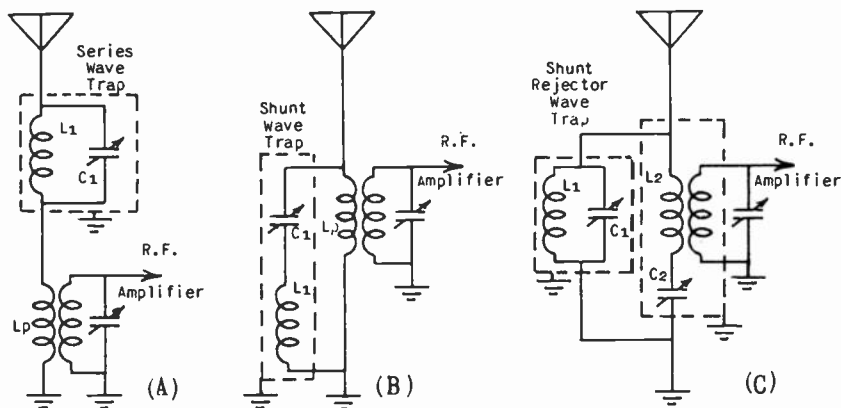

Fig. 24 (A) Series wave trap. (B) Shunt wave trap. (C) Shunt-rejector wave trap.

11. WAVE TRAPS. Wave traps are extremely useful for preventing code interference and cross modulation from strong local broadcast stations on radio receivers. Three types of wave traps are in general use for connection to a receiver. These are illustrated at A, B and C in Fig. 24. All wave traps eliminate the reception from undesired stations by the use of tuned circuits of either the series or parallel type. The characteristics of these tuned circuits were discussed in several lessons of Unit 1.

A series wave trap is shown at A in Fig. 24. It is simply a parallel resonant circuit ( $L_1-C_1$ ) tuned to the interfering fre-

quency, and is inserted in series with the lead from the antenna to the primary of the input transformer. From our knowledge of tuned circuits, we know that a condenser and coil connected in parallel and tuned to resonance at some particular frequency will offer a very high impedance to that frequency, thus, retarding its passage from the antenna into the primary of the input transformer and suppressing the interfering signal.

The shunt type wave trap, shown at B in Fig. 24, consists of a series resonant circuit (L1-C1) tuned to the interfering signal. It is connected in parallel with the primary of the antenna transformer. The condenser and coil, connected in series and tuned to resonance, offer an extremely low impedance path to the resonant frequency. Thus, the interfering signal is by-passed to ground and does not enter the primary winding of the antenna transformer.

Fig. 25 R.C.A. commercial wave trap for chassis mounting.

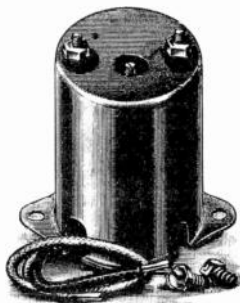

The shunt-rejector type of wave trap, shown at C in Fig. 24, is really a combination of a series and a parallel tuned circuit designed to suppress or reject effectively an undesired radio signal from entering the radio frequency amplifying portion of the receiver. L2-C2 constitutes a series resonant circuit and is tuned to the frequency of the desired signal. Since the series resonant circuit (L2-C2) offers a low impedance path for the resonant frequency to ground, a high current will pass through L2 at the desired frequency and thus induce the signal voltage desired into the secondary where it is fed into the amplifying portion of the receiver. The parallel tuned circuit L1-C1 is also tuned to the frequency of the desired signal, and thus offers a high impedance path to its passage. Since L1-C1 offers a low impedance path to the passage of all radio signals other than the desired signal, it serves as a shunt or by-pass for these signals around the high impedance path presented by L2-C2 at off-resonant frequencies. These two tuned circuits function in cooperation with each other to force the desired signal to take the path through L2-C2 and, at the same time, force undesired signals to pass through L1-C1.

In case the interference is caused by Airway or Coast Guard beacon stations operating on low frequencies (below 500 kc.), the inductance and capacitance values chosen for the wave trap circuit must be such as to resonate at the frequency of the unde-

sired, interfering signal. To tune a range from 350 kc. to 615 kc., a satisfactory size for the coil is .9 millihenries and, for the condenser, a variable capacity from 75 to 225 mmfd. In general, it is recommended that the shunt type wave trap be used for eliminating code interference in preference to the series type. This is because the shunt type has a very low impedance, while the series trap is high impedance, and greater care must be observed when locating the latter type on the chassis to avoid coupling between it and the RF or IF circuits. In extreme cases of interference, use of the shunt rejector wave trap, as illustrated at C in Fig. 24, is the most effective. Fig. 25 shows a photograph of a commercial wave trap designed for mounting on top of the chassis. It has a tuning range of approximately 434 to 620 kc. Most interfering code stations are located within this range.

Should the interference in the radio receiver be caused by cross-modulation from a strong local broadcasting station, it will then be necessary to use different inductance and capacity values to resonate at the frequency of the undesired signal and thus prevent it from entering the amplifying circuits of the radio receiver. The method of connection, however, may be according to any one of the three circuits illustrated in Fig. 24. Commercial units are available for installation in case the service engineer does not care to construct one from miscellaneous equipment which he might have on hand. In all cases, for a wave trap to be effective, it must be well shielded, and the shield grounded to the chassis of the receiver.



# Notes

*(These extra pages are provided for your use in taking special notes)*

The text of this lesson was compiled and edited by the following members of the staff:

G. L. Taylor  
President and Chief Engineer  
Midland Radio & Television Schools, Inc.

C. L. Foster  
Supt. of Instruction  
Midland Radio & Television Schools, Inc.

C. V. Curtis  
Chief Instructor  
Midland Radio & Television Schools, Inc.

R. E. Curtis  
Technical Drafting  
Midland Radio & Television Schools, Inc.

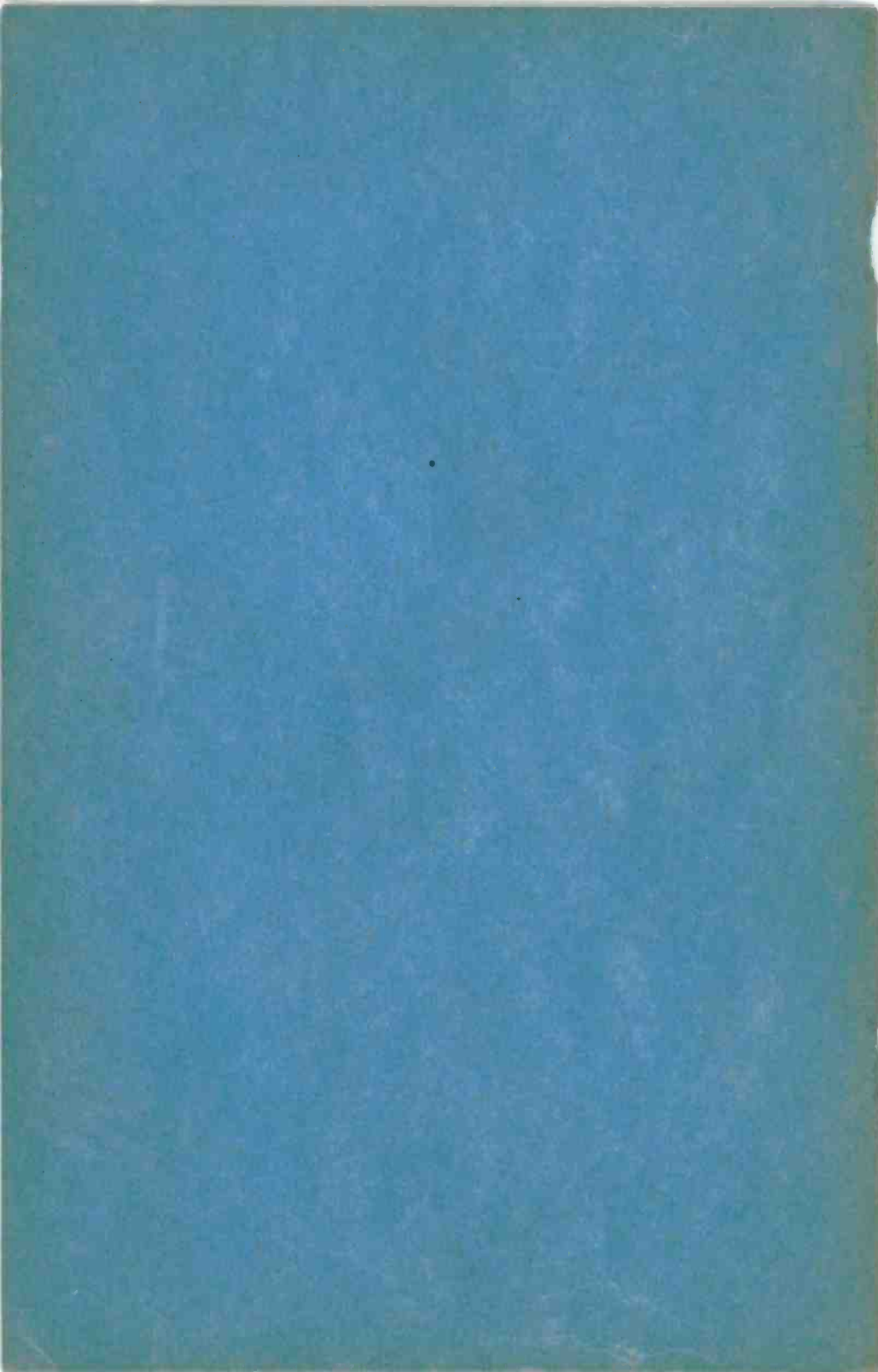





**MIDLAND RADIO  
AND TELEVISION  
SCHOOLS  
INC.**

**POWER & LIGHT BUILDING, KANSAS CITY, MISSOURI**

**UNIT  
NO.  
2**

**PUBLIC ADDRESS  
SYSTEMS**

**LESSON  
NO.  
9**

# PUBLIC ADDRESS

.....AND PRIVATE GAIN

Whenever you, as a Radio man, think about sound systems, you're apt to interpret the subject in terms of 'output' and 'response', and 'watts' and 'decibels'. That's fine, and it's just what Midland wants you to do.

BUT....your customer, let's say, together with all the rest of the generally interested public, doesn't know what those words mean. And what's more, he isn't interested. What the business-man wants to know about sound is, 'What is it, and what can it do for me and my business?'

Sound systems, or 'Public Address', is primarily a reinforcement of a weak sound. Remember that. And it can be used by any speaker whenever and wherever there is a crowd. He has more volume when he allies himself with a Sound System, than all the buzzing private conversations of his audience. That's what he wants.

There is something about human nature that makes each man just naturally the most important cog in the world's machinery. When you tell him his voice can drown out all other sounds, you are appealing to his sense of justice. His voice ought to drown out everything else.

Now, of course, that does not mean that all men think the same way about their voices. For example, a minister delivering his sermon would probably be more interested in knowing that he could reach farther back into the corners with his natural speaking voice. But don't overlook the fact that even the minister would like to think that more people come to his church because they could hear what he was saying.

There are literally hundreds of uses for Public Address, but they all come back to the same thing....amplification.

It's a human trait to want to be noticed. You want to be on the receiving end of attention, too.

That's the main reason you are reading this instruction manual. You want to learn more about Sound. Not because it is Sound, maybe, but because you want more knowledge. When you have more knowledge, you have 'more on the ball' than the next fellow.

EXTRA knowledge always pays dividends. Learn all you can; put your learning to work for you, and the returns should be in direct proportion.

Copyright 1942

By

Midland Radio & Television  
Schools, Inc.

PRINTED IN U.S.A.

**JONESPRINTS**

KANSAS CITY, MO.

# Lesson Nine

## PUBLIC ADDRESS SYSTEMS



"I am not divulging a secret when I say that the American public is "sound conscious." Public Address installation and service is one of the many branches in the art of radio wherein a well-trained man can realize a substantial livelihood.

"In this lesson, I shall give concrete facts and information that will enable you to take advantage of the potential possibilities offered by this field."

1. INTRODUCTION. Of all the various phases of radio servicing, the one that has shown the greatest advance in money making possibilities is that of public address and sound reinforcement installation and service. It seems that the public has, almost overnight, become accustomed to the advantages gained by being able to hear proceedings at public gatherings with natural quality. It is only a matter of time until all churches, auditoriums, schools, mortuaries, parks, playgrounds, etc., will be so equipped. Special uses of sound systems are too numerous to mention; we list only a few as follows:

- All public gatherings
- Advertising (talking signs and sound trucks)
- Centralized radios (hotels and apartment buildings)
- Electric chimes (churches and cemeteries)
- Call systems (factories, restaurants, offices, etc.)
- Classroom systems (schools and colleges)

This list will serve to suggest many other possibilities for P.A. installations. The service-engineer who is capable of estimating such installations successfully and accurately cannot help but make money from both the original sale and the service upkeep. Many installations are so large that the upkeep of the equipment is a full time and well paid job for a trained man.

A public address installation is one which amplifies a program or an address to enable a far larger group of people to intelligent-

ly hear the source of sound than otherwise could without such assistance. It generally consists of one or more microphones, amplifiers and reproducers, or loudspeakers, all with suitable controls. The system may be only a temporary installation for one specific event, place and time, and to fulfill a sole purpose or it may be an in-built and permanent installation of program amplifying and distributing components with flexible facilities for adaption to any or all demands within its scope. This latter type of installation is commonly known as a "sound distribution" system and finds most of its applications in auditoriums, halls, theatres, etc. Both systems, public address and sound distribution, consist of the same components and fulfill the same fundamental purpose. The distinction is generally made that a "public address" system is a temporary installation to fulfill the requirements of only one event, whereas a "sound distribution" system is considered to be a permanently installed and permanently wired arrangement.

There are many factors that enter into the estimating of a sound amplifying installation. Among these are: the power of the amplifiers, the type and placement of speakers, acoustics of the hall, etc. These factors are not a matter of guesswork; and guesswork will never make a profit. Some of this information has been worked out in the form of convenient tables that eliminate the undesirable element of guesswork. It is best to use such compiled data whenever possible.

2. USE OF THE DECIBEL. The human ear responds logarithmically to variations in sound intensity; hence, any practical unit that is used to compare sound levels must also vary logarithmically. Such a unit is the "decibel," which is one-tenth (deci) of the accepted transmission unit, the "bel" (named in honor of Alexander Graham Bell, inventor of the telephone). The word "decibel" is frequently abbreviated "db." In the past ten years, the use of the decibel system for audio frequency measurements has become quite general and anyone who is working with audio frequency apparatus will encounter it frequently.

In this study of P.A. installations, it is not advisable for us to diverge from the subject and explain the mathematics involved in computations dealing with the decibel unit. Such mathematics requires the use of logarithms which, so far, have not been discussed in our course of training. Complete information on the decibel, as well as the mathematics followed when calculating decibel problems, will be discussed in Lesson 2 of Unit 4. However, to become sufficiently acquainted with the use of the unit so that you may understand the mechanics of it as used in various portions of this lesson, we shall discuss it briefly and indicate the solution of a few typical problems.

The decibel is used to express the logarithmic ratios of powers, voltages, or currents in audio frequency amplifying systems. In this capacity, it is very useful when we desire to express gains in amplifying systems, losses in attenuating resistor networks or when comparing the electrical output of any piece of audio equipment with a standard value.

A person who is sufficiently fortunate to possess acute hear-

ing power can detect a change in the sound intensity of a single sustained note when the level is varied 1 decibel. Changes in sound intensity of less than 1 decibel cannot be readily ascertained by the ear. Therefore, as a simple definition, we may state that a *decibel is the smallest change in sound intensity that can be detected by well-trained human ears.* Ordinarily, the average person does not notice a change in level of the sound issuing from a loud-speaker unless it is greater than 3 db.

The decibel system uses logarithms as its basis and is, therefore, well-suited for dealing with sound levels as heard by the ear. A curve, for example, plotted in decibels will more nearly approach a true picture of the effects of a given series of sounds on the ear than any other system. The decibel system has the further advantage that it coincides exactly with the nature of an audio signal traveling through a telephone line, cable or artificial attenuator. As a matter of fact, the whole decibel system was devised by telephone men for their own convenience in handling cable calculations. The action of a cable is obviously a logarithmic one since, for example, a given signal may be .1 its original strength at the end of the first mile and, at the second mile, it will be .1 of the strength at the end of the first mile (.01 of the original) and so on through the line.

Now, by definition, a *bel is the logarithm of the ratio of the power output to the power input*, and a decibel, or .1 of a bel, is therefore 10 times the same logarithm, such as:

$$\text{db. (decibel)} = 10 \times \log \frac{\text{Power Output}}{\text{Power Input}}$$

With this relationship in mind, let us try a few calculations. Assume that we are delivering a 10 watt signal into an amplifier and are getting 100 watts of audio power out of the amplifier. The power ratio of the output to the input will then be 100 to 10, or is simply equal to 10. Now the logarithm of 10 is 1, so the gain in signal level expressed in db. through the amplifier would then be  $10 \times 1$ , or 10 db.

This example is a very good one to memorize, since it enables one to make easy mental calculations of db. values when a logarithm table or a slide rule is not at hand. Expressed in words, we may say that each increase of 10 times the original power corresponds to an increase of 10 db. Another easy relation to remember is that if the power output of an amplifier is doubled, the gain is increased by 3 db. Since the log of 2 is .301 and  $10 \times .301$  is 3.01, or approximately 3, this relationship is true.

So far we have confined our remarks to increases in power and have said nothing in regard to another frequently used term; i.e., "power level." The term "power level" implies that we have previously agreed to select a given amount of power as a so-called "zero level." Whenever the expression "power level" is used, we must have in mind the relationship between that particular power to the previously selected zero value. For example, if we say that we shall consider 12.5 milliwatts as the "zero level," then the output of an amplifier delivering 12.5 watts will be:

$$\begin{aligned} \text{db. level} &= 10 \times \log \frac{\text{Power Output Level}}{\text{Zero Power Level}} \\ &= 10 \times \log \frac{12.5 \text{ watts}}{.0125 \text{ watts (12.5 milliwatts)}} \\ &= 10 \times \log 1000 \end{aligned}$$

The logarithm of 1000 is 3 so:

$$\text{db. level} = 10 \times 3 = 30 \text{ decibels}^1$$

It is very unfortunate that all zero levels are not the same. Some reference levels in general use are: the RCA and NBC systems, 12.5 milliwatts; A.T.&T. and Bell Telephone Laboratories, 6 milliwatts; and the Navy, 1 milliwatt.

These varying standards for zero power level serve to illustrate the importance of knowing to what the speaker is referring when he mentions a given power level or db. level. In this connection, it might be well to point out that if you are using a meter which is calibrated in db. with 6 milliwatts as the zero level, a simple calculation can be made to convert the reading to the 12.5 milliwatt basis as follows: We said earlier that doubling the power output is equivalent to a gain of 3 db. In this case, we are increasing the hypothetical input power by 12.5 divided by 6, which is slightly more than double and which, therefore, would correspond to a loss of approximately 3 db. for the same power output. When using a meter calibrated to 6 milliwatts, correct values referred to 12.5 milliwatts can be obtained by subtracting 3 db. from the meter reading.

In radio work, the 12.5 milliwatt zero level will be encountered just as often as the 6 milliwatt zero level, so it is advisable to learn the relationship existing between these two reference values as stated above. Telephone lines, such as used to connect broadcast stations, broadcast transmitters, etc., all use 6 milliwatts for the zero level, whereas RCA control room audio frequency equipment has a decibel rating based on the 12.5 milliwatt zero level.

A chart showing the relationship between various db. levels and the corresponding power at that level (based on 12.5 milliwatts) is given in Fig. 1. Thus, using 12.5 milliwatts as reference, an example illustrating the use of the word "decibel" would be: "The output of the amplifier is +30 db.," which is the same as saying: "The power output of the amplifier is 12.5 watts." Likewise, we could say that the average output of a velocity microphone is -70 db., which is seen from Fig. 1 to be a very small fraction of a watt. From the chart, it is apparent that doubling the power output of an amplifier does not also double the db. level; that is, the actual intensity of sound issuing from the loudspeaker. If the

<sup>1</sup> This problem is worked using a zero reference level of 12.5 milliwatts. All RCA equipment is rated on this level. Broadcast telephone lines using 6 milliwatts as the reference level for 0 db.

db. level is increased from 10 to 20 (doubling its value), the power output of the amplifier must be increased from .125 watts to 1.25 watts; a power increase of 10 times. All through the chart it is

DB LEVEL	WATTS POWER
+ 40	125.0
+ 30	12.5
+ 20	1.25
+ 10	.125
0	.0125
- 10	.00125
- 20	.000125
- 30	.0000125
- 40	.00000125
- 50	.000000125
- 60	.0000000125
- 70	.00000000125
- 80	.000000000125
- 90	.0000000000125
-100	.00000000000125

Fig. 1

DB POWER LEVEL VERSUS WATTS POWER.

seen that for each 10 db. increase in sound level, the power output of the amplifier must be increased 10 times and, likewise, for each 10 db. decrease in sound level, the output of the amplifier must be decreased 10 times. Bear in mind that the decibel is the unit of actual sound intensity, so doubling the decibel value doubles the intensity of the sound to the ear; but, doubling the electrical power output does not produce sound intensity from a loudspeaker that seems twice as loud.

The chart on the left in Fig. 2 shows the power in watts corresponding to several intermediate db. levels between zero and +40.

WATTS POWER	DB LEVEL	DB GAIN	AMPLIFICATION
.0125	0	0	1
.125	+10	3	2
1.25	+20	6	4
2.5	+23	10	10
5.0	+26	13	20
10.0	+29	16	40
12.5	+30	19	80
20.0	+32	20	100
25.0	+33	23	200
40.0	+35	26	400
50.0	+36	30	1000
80.0	+38	40	10,000
100.0	+39	50	100,000
125.0	+40	60	1,000,000
		70	10,000,000

$$\text{Amplification} = \frac{\text{Output Power}}{\text{Input Power}}$$

CHART of GAIN at POWER LEVELS

Fig. 2

The chart on the right shows the actual gain in db. as plotted against the power ratio. The power ratio in this case means the overall power amplification obtained through an audio amplifying system; that is, amplification equals output power divided by input power. Notice that doubling the power amplification produces a gain of approximately 3 db. in any case. For example, doubling the power

amplification from 2 watts to 4 watts gives a db. gain of from 3 to 6. Likewise, doubling the power amplification from 100 to 200 watts gives a db. gain from 20 to 23, etc.

To illustrate how the decibel is used when working with audio frequency circuits, let us refer to Fig. 3. Here the output of the microphone is taken as -113 db. Then, through the pre-amplifier,

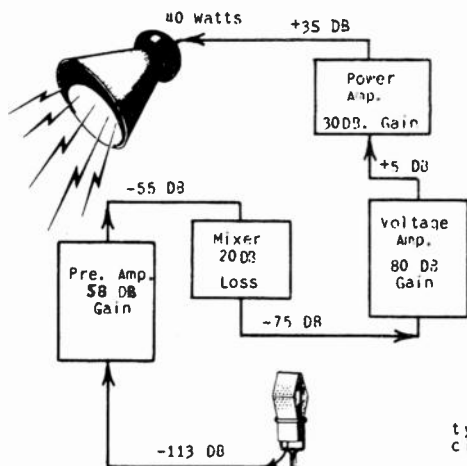

Fig. 3 Db. levels through typical A. F. amplifying circuit.

this level is increased to -55 db. The "mixer" (used for controlling volume) introduces a 20 db. loss, which returns the level to -75. Then, the A.F. signal is fed through a voltage amplifier having an 80 db. gain, which raises the level to +5 db. The 5 db. audio signal is now fed into a power amplifier having a total gain of 30 db., from which it emerges at a level of +35 db. Referring to the chart on the left in Fig. 2, this is seen to correspond to a power of 40 watts; hence, there are 40 watts of audio power delivered into the loudspeaker. The total db. gain through these amplifiers is from -113 to +35, or an overall db. gain of 148. This takes into consideration the loss inserted by the mixer or volume control circuit.

From this discussion, you should become sufficiently well acquainted with the decibel so that audio levels spoken of in terms of this unit will be intelligible to you. Complete information is given in Lesson 2, Unit 4.

**3. MICROPHONES.** A microphone is used to convert sound waves into corresponding audio frequency currents. It is one of the essential parts in all public address systems. The quality of sound reproduction from a loudspeaker can be no better than the characteristics of the microphone. This is quite obvious when we consider that the microphone is actually the generator of the exciting voltages for the audio amplifier, which in turn drives the loudspeaker. So, particular care should be taken in the selection of the microphone if high quality reproduction is desired.

The microphone's output level in db. is a second factor which



requires consideration. Some microphones produce a relatively high audio output and others give a low output. A "sensitive" microphone is one capable of producing a relatively high db. output when excited at a given sound energy level, whereas, a "less sensitive microphone" is one producing a lower db. output at the same sound level. As a general rule, it can be estimated that the higher the sensitivity of a microphone, the poorer the tone quality or frequency response; and that, the better the frequency response, the lower the sensitivity. This is the same as saying that the tone quality (frequency response) of a microphone is generally inversely proportional to its sensitivity, but directly proportional to price. It will be found that the less sensitive microphones are generally much more expensive.

Sound waves are measured in a unit called the "bar." This unit provides a means of expressing the pressure or force per unit area on a flat surface. A bar is defined as a pressure equal to one dyne per square centimeter. This definition is of little practical value unless we compare it with more commonly known units of measurement. The dyne is an extremely small unit and, for comparison, let us state that there are 444,823 dynes in one pound. Now

Various Noises and Orchestral Effects	RMS Sound Pressure	RMS Particle Velocity	Total Particle Excursion	Sound Intensities	Power Level
	Dynes per Sq Cm	Cm per Sec	Millimeters at 1,000 Cycles	Microwatts per Sq Cm	Deci- bels
Threshold .....	0.000204	0.0000050	$2.22 \times 10^{-8}$	$10^{-10}$	0
	0.000363	0.0000089	$3.95 \times 10^{-8}$	$3.165 \times 10^{-10}$	5
	0.000645	0.0000158	$7.00 \times 10^{-8}$	$10^{-9}$	10
	0.001146	0.0000281	$1.25 \times 10^{-7}$	$3.165 \times 10^{-9}$	15
Whisper 4' from source.....	0.00204	0.000050	$2.22 \times 10^{-7}$	$10^{-8}$	20
	0.00363	0.000089	$3.95 \times 10^{-7}$	$3.165 \times 10^{-8}$	25
Soft Violin 12' from source...	0.00645	0.000158	$7.00 \times 10^{-7}$	$10^{-7}$	30
	0.01146	0.000281	$1.25 \times 10^{-6}$	$3.165 \times 10^{-7}$	35
	0.0204	0.0005	$2.22 \times 10^{-6}$	$10^{-6}$	40
	0.036	0.00089	$3.95 \times 10^{-6}$	$3.165 \times 10^{-6}$	45
Bell F4 160' from source...	0.0645	0.00158	$7.00 \times 10^{-6}$	$10^{-5}$	50
Ordinary Conversation 3' from source	0.1146	0.00281	$1.25 \times 10^{-5}$	$3.165 \times 10^{-5}$	55
	0.204	0.0050	$2.22 \times 10^{-5}$	$10^{-4}$	60
	0.363	0.0089	$3.95 \times 10^{-5}$	$3.165 \times 10^{-4}$	65
Bell F2 160' from source...	0.645	0.0158	$7.00 \times 10^{-5}$	$10^{-3}$	70
	1.146	0.0281	$1.25 \times 10^{-4}$	$3.165 \times 10^{-3}$	75
Full Orchestra .....	2.04	0.15	$2.22 \times 10^{-4}$	$10^{-2}$	80
Bell F4 6' from source.....	3.63	0.089	$3.95 \times 10^{-4}$	$3.165 \times 10^{-2}$	85
	6.45	0.158	$7.00 \times 10^{-4}$	$10^{-1}$	90
	11.46	0.281	$1.25 \times 10^{-3}$	0.3165	95
	20.4	0.5	$2.22 \times 10^{-3}$	1.0	100
Bell F2 6' from source....	36.3	0.89	$3.95 \times 10^{-3}$	3.165	105
	64.5	1.58	$7.00 \times 10^{-3}$	10.0	110
Thunder .....	114.6	2.81	$1.25 \times 10^{-2}$	31.65	115
Hammer 2' from source.....	204	5.0	$2.22 \times 10^{-2}$	100.00	120
	363	8.9	$3.95 \times 10^{-2}$	316.5	125
Threshold of pain.....	645	15.8	$7.00 \times 10^{-2}$	1000.0	130

Courtesy "Communications"

to obtain a more practical conception of the amount of sound pressure exerted by one bar, let us convert the unit into the following:

One bar equals .0020387 pounds per square foot  
 Or: One bar equals .000014504 pounds per square inch

The accompanying chart will be found helpful in determining the acoustical level of various common sounds (on page 7).

In order to compare the output of the various microphones, it is necessary to assume the same sound wave pressure exerted on the diaphragm of each. The following table may be used for comparing some of the microphones available for general broadcast and P.A. work. The sound pressure in each case is 10 bars. The chart also shows the frequency response for each of the microphones.

TYPE	APPROXIMATE OUTPUT IN DB. AT 10 BARS	AVERAGE FREQUENCY RANGE IN CYCLES
RCA VELOCITY (Professional Broadcasting)	- 67	60 - 16,000
RCA VELOCITY (P.A. Work)	- 63	50 - 8,000
RCA VELOCITY (Lapel)	- 80	80 - 8,000
Carbon	- 45	50 - 6,000
Inductor (Dynamic)	- 63	60 - 10,000
Condenser	- 85	60 - 10,000
Crystal	- 60	30 - 10,000
Velotron	- 53	50 - 8,000

A detailed study of the construction and operation of microphones will be included in Lesson 2 of Unit 4. It is impossible to completely explain each type of microphone in this lesson, but let us briefly review the various types available and learn of their adaptability to P.A. work.

Microphones fall under two general classifications, velocity and pressure. Velocity microphones are frequently known as "ribbon microphones." A ribbon microphone operates on the "difference in pressure" principle; unlike a pressure microphone, there is no diaphragm wall to stop the sound waves. Sound waves passing through the microphone cause a ribbon movement by producing a pressure difference between the two faces of the ribbon. Audio voltages are generated in the ribbon as it moves through a strong magnetic field. These voltages correspond to the compressions and rarefactions of the sound waves.

A pressure microphone operates on a "sound pressure" principle, as the name implies. When a sound wave pushes against the diaphragm, displacement of the diaphragm from its mid-position takes place, resulting in movement of the voltage generating medium, whether it be the compression of carbon granules, the movement of an inductor bar, the movement of a voice coil, or a change in capacity of condenser plates. The principle is the same in all cases. A wave of rarefaction follows a wave of compression and causes the diaphragm to move in the opposite direction. It moves back to the zero mid-point, then moves forward from the mid-point and generates the negative alter-

nation of the audio voltage.

The main differences between velocity and pressure operated microphones for P.A. work exist in the directional characteristics of the two devices. A in Fig. 4 shows the characteristics of the average pressure operated microphone and B in the same figure shows the average frequency characteristics of a velocity microphone. For the pressure operated types, it is interesting to note that at frequencies below 800 cycles, the pickup is in a perfect circle around the diaphragm. However, for frequencies around 2,000 cycles, there is a preference to the diaphragm side; then for the higher sound frequencies of 4,000, 6,000, 8,000 and 10,000 cycles, the level drops considerably from any angle except that perpendicular to the diaphragm of the microphone. It is easy to realize the shortcomings of pressure type microphones in connection with an orchestra pickup, because all instruments having high frequency response must face the diaphragm. You can readily appreciate that it would be impossible to place all members of a 100 piece orchestra directly in line with a single microphone diaphragm. To prevent the angular frequency discrimination of pressure microphones, several of them may be used, but this often results in overlapping and distortion.

The directional characteristics of a velocity microphone, shown as B in Fig. 4, indicate that the pickup within the outer circle covers all frequencies from 90 to 16,000 cycles. At a 45° angular position, we note a drop in level of approximately -3 db. which takes place equally at all frequencies. Moving to the edge of the so-called "beam" of the velocity microphone results in a loss of output, but the frequency response ratio remains constant. The drop in level caused by angular operation can easily be compensated for by the mixer or volume control circuit. In the case of angular operation with a pressure microphone, it is impossible to restore the lost frequencies even with the volume control advanced, because raising the gain results in a voice "boom" due to the greater low

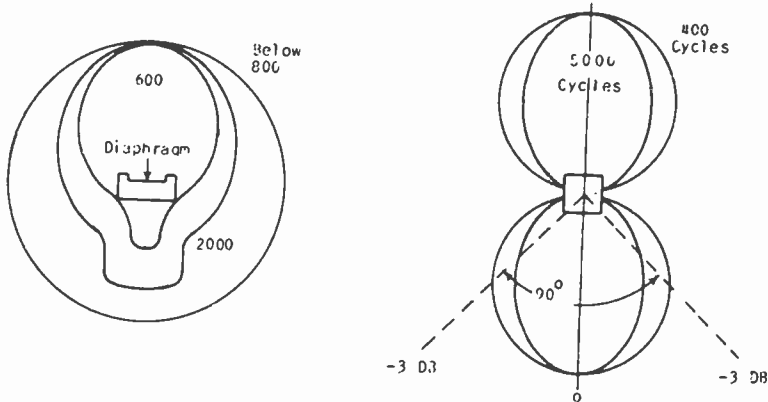

Fig. 4 (A) Directional characteristics of pressure operated microphones.  
(B) Directional characteristics of velocity microphones.

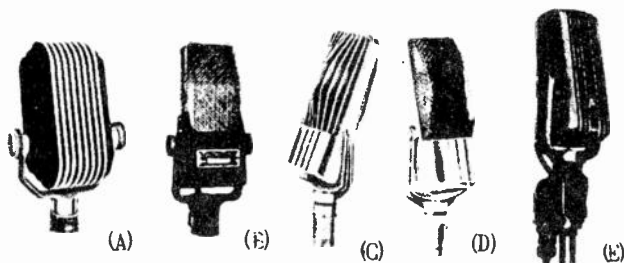

Fig. 5 various types of velocity microphones. (Courtesy "Communications.")

frequency response in proportion to highs.

In some P.A. applications, it is not desired to pick up the sound waves except from one direction. For these cases, pressure operated microphones are much more satisfactory than those of the velocity type. For example, during the pickup of an orchestra in a dance hall, the crowd noise is undesirable, so the "dead" side of a pressure microphone may be turned toward the crowd.

The professional broadcasting velocity microphone listed in the chart on Page 8 is used almost exclusively for radio broadcasting purposes. The response of 60 to 16,000 cycles is particularly suitable for broadcast work, having excellent music and voice characteristics. This type of microphone is more expensive than those generally used for P.A. work.

The lapel velocity microphone was developed to meet the need of public speakers. It is designed specifically for voice operation, and its output is rather low because of the small ribbon that is used. A high gain amplifier must be used following this microphone to produce the desired volume level from the loudspeaker. Five velocity microphones suitable for P.A. work are shown in Fig. 5.



Fig. 6 Photograph of carbon microphone. (Courtesy "Universal Microphone Company")

Carbon microphones find their greatest applications in the low priced P.A. field. They answer the need of a low priced instrument with fair quality and high output level. The double-button carbon microphone is excellent for home recording, police transmitters, etc. Even though a higher output is secured from the sensitive car-

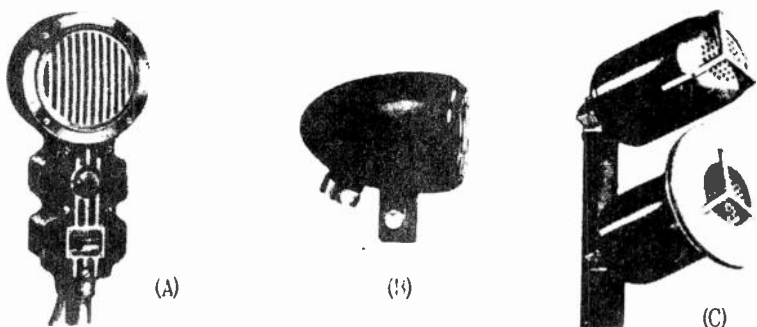

Fig.7 Various types of dynamic microphones. (Courtesy "Communications.")

bon mike, a sacrifice is made in tone quality. A carbon microphone requires a DC exciting current which must be secured from batteries, or possibly from the DC supply in the amplifier. Carbon microphones have a tendency to become "packed" when subjected to mechanical abuse. When followed by a high gain amplifier, the carbon "hiss" is sometimes quite objectionable. Present day P.A. installations generally use a higher quality microphone than the carbon, even though they are less sensitive and more expensive. The carbon type was very popular until about 1934. A photograph is shown in Fig. 6.

The inductor or dynamic microphone is a high quality pressure-type instrument developed to meet the needs of outdoor work and general speech requirements. The wide frequency response of an inductor microphone results in excellent quality. This microphone is quite expensive; therefore its use is rather limited to radio broadcasting and to those sound reinforcement installations that are permanently installed in large auditoriums, schools, etc. Three late types of dynamic microphones are shown in Fig. 7.

A condenser microphone is also a pressure operated type. From the chart on Page 8, it is seen that the output is extremely low, but its frequency response is excellent. This type of microphone operates on a principle wherein the capacitance of a small condenser is varied by the impinging sound waves. Current variations through this changing capacity pass through a high resistor and the audio voltage variations are developed across it. Due to the extremely weak output of this type of microphone and also due to its high im-

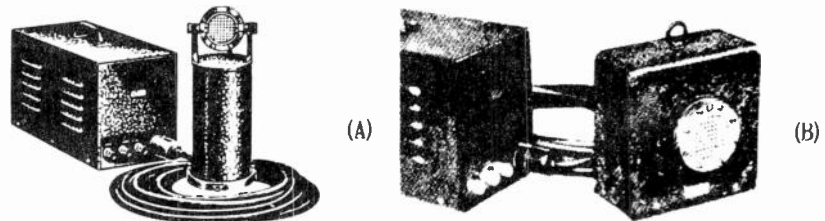
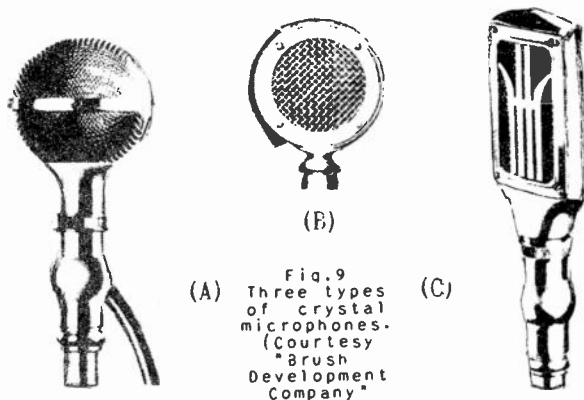

Fig.8 Two types of condenser microphones showing head amplifiers. (Courtesy "Universal Microphone Co.")

pedance, it is impossible to transmit the audio output over any appreciable distance. Therefore, an audio amplifier must be used directly following the output of the microphone. The amplifier is generally located directly within the case containing the microphone "head," and is called the "head amplifier." Thus, a complete condenser microphone is large in size, heavy in weight and expensive. These disadvantages prevent its popular use on all except the more elaborate, permanently installed P.A. systems. Two condenser microphones, with the "head amplifier" attached, are shown in Fig. 8.

A crystal microphone also operates on a pressure principle. It depends upon the deforming of a piezo-electric crystal for the A.F. voltage generation. The amplitude of voltage output varies with the sound wave pressure exerted on the crystal. A crystal microphone can be built to operate with or without a diaphragm, the former type having the higher sensitivity. Crystal microphones have a high internal impedance; therefore, a low-capacity, shielded cable must be used to connect it to the amplifier. In spite of the fact that the db. output is fairly low and that it is a high impedance device, the crystal microphone is experiencing great popularity at the present time in the general field of P.A. work. This microphone is rugged, portable, and not seriously affected by weather conditions unless they become extreme. Its frequency response is good and, above all, the unit is gaining popularity because of its performance vs. cost qualifications. Good crystal microphones can be purchased at a nominal price and, with the modern, high-gain tubes now available, the low db. output does not offer a material disadvantage. In Fig. 9, three crystal microphones are shown. A and C are cell-type units and B is a diaphragm type.



**4. SPEAKERS FOR P.A. SYSTEMS.** Selection of the proper speaker system for public address amplifiers depends largely upon the type of installation. The cubic volume of the area to be covered, the type of baffle employed and the power of the amplifier used are all determining factors for the speaker selection and placement. The following chart will be found helpful as a starting point toward determining the type of loudspeaker to be used for various applica-

tions. In this section of the lesson, we shall discuss those types of loudspeakers available for P.A. work, then in later sections,

APPROXIMATE ELECTRICAL POWER IN WATTS TO VARIOUS TYPES OF LOUDSPEAKERS.						
Volume of room in cu. ft.	Directional Baffle	Large El. Dy. Sp. using 100 mill field on Flat Baffle*	Small El. Dy. Sp. using 70-80 mill field on flat baffle*	Large Per Mag. Dy. Sp. on Flat Baffle*	Small per. Mag. Dy. Sp. on Flat Baffle*	Mag. Sp. On Flat Baffle*
1,000	0.05	0.2	0.4	0.8	1.2	1.2
2,000	0.1	0.4	0.8	1.6	2.4	2.4
4,000	0.2	0.8	1.6	3.2	4.8	4.8
8,000	0.4	1.6	3.2	6.4	9.6	9.6
20,000	1.5	6.0	12.0	24.0	36.0	36.0
50,000	3.0	12.0	24.0			
100,000	5.0	20.0	40.0			
250,000	10.0	40.0				
600,000	20.0					
1,500,000	40.0					

\* Flat Baffle is used here to mean speaker mechanism mounted on a Flat Baffle in free space, or mounted flush in wall with plaque, or mounted in box on wall surface.

give more specific information as to their selection and installation.

For the most part, the loudspeakers used on P.A. installations are of the moving-conductor or dynamic type. Moving armature (magnetic) speakers are not capable of handling the amount of audio power necessary to reproduce the loud volume required of most P.A. installations. When the installation is to cover only a very small area, magnetic speakers may be satisfactory; however, such is generally not the case, so we shall confine our discussion to reproducers of the dynamic type.

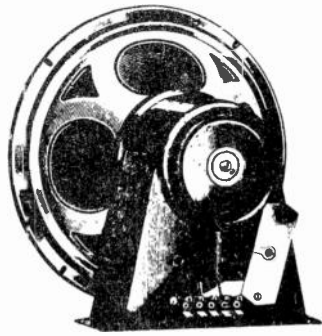

Fig. 10 12-inch electrodynamic speaker without field power supply.

Until recently, only electrodynamic speakers were used to any great extent. These speakers are still the more popular; however, permanent magnet dynamic speakers have partially supplanted electro-dynamics on some of the smaller installations. Where over 15 watts of audio power are to be handled, it is necessary that the reproducer be of the electrodynamic type because, at the present time, 15 watts is about the maximum handling capacity of permanent magnet dynamic speakers.

Fig. 11 18-inch electro-dynamic speaker with field power supply. (Courtesy Jensen Radio Mfg. Co.)



A typical 12-inch heavy duty P.A. speaker is shown in Fig. 10. A speaker of this size handles from 10 to 15 watts of audio power with a minimum of distortion. It is designed particularly for heavy duty service, thus making it ideal for most public address applications. This 12-inch speaker does not have a built in power supply for the field winding; hence, it is necessary to deliver the field exciting current through a cable from the main amplifier. The audio power to be delivered to the voice coil must also be supplied through a cable. Connections to the voice and field coils are made to a recessed terminal board on the back.

An 18-inch electro-dynamic speaker with its own field power supply is shown in Fig. 11. The field power supply is secured from a vacuum tube rectifier circuit, the tube being located within the perforated shield on the left side of the speaker. The power transformer and filter condenser are contained within the enclosure on the bottom of the speaker. The power handling capacity of this 18-inch speaker is from 20 to 25 watts continuously. The field coil consumes a maximum power of 30 watts and a minimum of 20 watts.

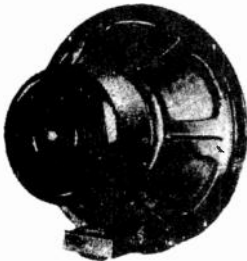

Fig. 12 15-watt permanent magnet dynamic speaker. (Courtesy Jensen Radio Mfg. Co.)

Normally, such a speaker should be supplied with about 26 watts of DC power. The voice coil has an impedance of 8 ohms at 400 cycles; but 12 and 15 ohm voice coils can be secured by special order. Input transformers can also be secured which will enable the speaker to be operated from a 250 or 500 ohm audio transmission line. This type of speaker is especially adaptable for installation in theatres, large auditoriums or for use in directional baffles where large outdoor areas are to be covered.



A P.M. (permanent magnet) loudspeaker is shown in Fig. 12. Speakers of this type have numerous applications in the field of public address and sound reinforcement work. They are particularly advantageous in that no field exciting power is necessary. Their popularity is also greatly enhanced by the fact that the front to back dimension is unusually short, due to the absence of the large

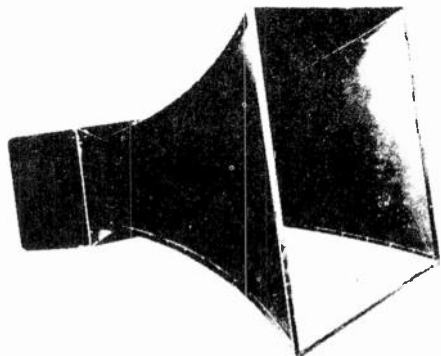

Fig. 13 Type 41 Operadio directional horn baffle. (Courtesy Operadio Mfg. Co.)

field coil winding. This is immediately recognized as a distinct advantage by those who have experienced the installation of sound reinforcement systems in schools, hospitals, etc. The absence of the field coil allows all the speakers to be connected to the centralized amplifier with a two conductor cable, thus simplifying the conduit wiring and reducing the overall cost of the installation. A P.M. speaker, however, is slightly more expensive than an electrodynamic when compared on the basis of the same power handling capacity.

Flat baffles on P.A. installations are not in general use, due to the fact that more amplifier power is required to cover a given area. This is evidenced by the chart on page 13. Directional baffles or horns are used almost entirely on both large indoor and outdoor installations. The construction of a horn is an exceedingly important matter and not to be accomplished by just any convenient means of supporting an air column on the cone of the speaker. As a matter of fact, the design of the horn is just as important as the design of the speaker with which it is used, although of course, less complex. The best speaker will reproduce with distinctly inferior quality when associated with any other than a well and accurately designed horn.

The purpose of a horn is to increase the efficiency of a speaker by providing a better "grip" on the air by the speaker diaphragm. This increased efficiency produces the effect of projecting sound at greater distances or at a greater intensity through shorter distances and, furthermore, it tends to control the direction of the reproduced sound and the intensity with which it is delivered to selected areas. The object of designing a horn is to select a band of frequencies where increased efficiency is wanted and then provide proper means of confining an air column of correct shape and length.

Fig. 14 Wide-angle sound projector. (Courtesy Jensen Radio Mfg. Co.)

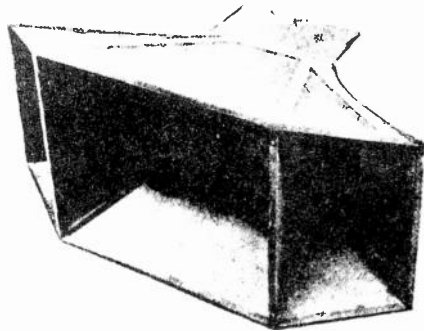

Such a device when properly designed may be called an "exponential" horn.

A typical horn type directional baffle is shown in Fig. 13. This is a true exponential horn, especially designed for use with electrodynamic speakers of the 12-inch size. It is made of strong material, firmly supported and constructed. The speaker housing is provided with a back cover to prevent the speaker from damage and to prevent undesirable backtalk from the same. The directional horn baffle illustrated in Fig. 13 is a highly-engineered product of the Operadio Manufacturing Company. The bell opening is 50 inches wide by 38½ inches high. The overall length of the baffle is 48½ inches. This type of horn baffle is very satisfactory for use on sound cars, in theatres and in large auditoriums.

A wide-angle sound projector is shown in Fig. 14. This is a new type of horn and is well suited to many applications. It is particularly suited for use in front of bandstands, in stadiums, for large open-air ground crowds, for covering passenger loading areas at airfields, for covering large indoor areas such as airplane hangars; in fact, any place where announcing and voice are the chief requirements. These reflectors are not recommended for the reproduction of sound if the best quality is desired, and hence they are not proposed for use in theatres or similar applications. For these uses, two exponential projectors are recommended instead. The wide-angle reflector illustrated in Fig. 14 has the following dimensions: overall length, 42 inches; extreme width, 69½ inches; height, 33 inches; width at center sections, 37½ inches; side sections, 17½ inches. The net weight of the reflector is 75 pounds. It is a product of the Jensen Radio Manufacturing Company.

A different type of wide angle sound projector is shown in Fig. 15. This projector is designed for use where space is limited and acoustical problems are difficult. It is only 25 inches long and, having a high low-frequency cutoff, the boominess of voice is eliminated and music is clear and crisp. The distribution angle is 60°, both horizontally and vertically, giving a wide angle for short halls. The cellular construction of the baffle insures excellent high frequency distribution. The length, width and height of the cellular baffle illustrated in Fig. 15 is 25 inches. The net weight is 50 pounds. The rear enclosure provides for a 12 inch dynamic speaker. It is an RCA product.

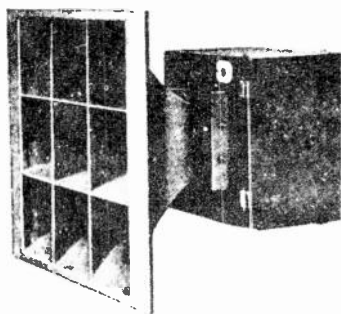

Fig.15 Cellular-baffle type of wide-angle sound projector. (Courtesy R.C. A.)

For broadcast station studios, auditions, client and monitoring rooms, laboratories, homes, or for any purpose where a high quality, rich appearing loudspeaker is desired, a cabinet baffle as illustrated in Fig. 16 is ideal for installation. These elaborate cabinet baffles generally employ two speakers; one for low and middle frequency response and one for high frequency response. Controls are then provided to regulate both the extent and the loudness of the low and high frequency response. These controls permit the reproducer to perform the most critical monitoring and reference work, or adjustment may be made to meet the particular preference of the listener as, for instance, in audition and entertainment applications. The

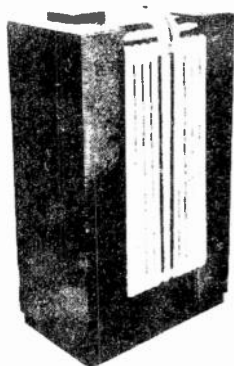
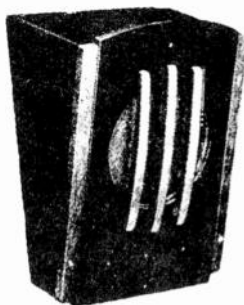

Fig.16 Jensen Peri-dynamic delux cabinet baffle; (Courtesy Jensen Mfg. Co.)

control assembly and necessary switches are installed in a compartment at the top of the cabinet and concealed by a hinged lid, fitted with a lock to prevent tampering of the variable controls.

Either permanent magnet or electrodynamic speakers may be installed in the large cabinet baffle. Such baffles are particularly designed for high fidelity reproduction, their frequency range extending down to 30 cycles and as high in frequency as the design

Fig. 17 Wall mounting cabinet-baffle for smaller speakers. (Courtesy Jensen Radio Mfg. Co.)



of the loudspeakers will permit. The dimensions of the cabinet baffle illustrated in Fig. 16 are as follows: 45 inches high; 27½ inches wide; 19 inches deep.

A small and compact, yet efficient, type of speaker baffle is illustrated in Fig. 17. These are used widely in centralized sound systems, such as installed in schools, hospitals, hotels, etc. They may be secured in various sizes; the one illustrated permitting the installation of an 3 inch P.M. speaker. These types of baffles may be mounted on the wall, over a door, or may be turned top side down and conveniently placed on a desk, table, or similar surface. When installed on a wall, the speaker beam is directed downward at an angle of approximately 18° from the vertical. The dimensions of the baffle illustrated in Fig. 17 are as follows: 12 inches wide; 16½ inches long; 4 inches deep at the bottom; 8 inches deep at the top.

Recently, a new type of speaker-baffle unit has been developed by the Jensen Radio Manufacturing Company. Speaker-baffle units incorporating this new principle are known as "peri-dynamic" reproducers. Peri-dynamic means "enclosed dynamic". In the application of the peri-dynamic principle, only that energy radiated from one side of the speaker diaphragm is directed into free space, for the speaker is otherwise totally encased in a rigid enclosure. Such a device allows performance in the low, middle and high frequency ranges resembling that of an infinite baffle. Extended low frequency response is acquired and improved through the use of a "bass-reflex" system which is a part of the peri-dynamic principle.

The Jensen bass-reflex system involves the coupling of the diaphragm of the low frequency speaker to an aperture in an otherwise totally enclosed cabinet so that an acoustic circuit is accomplished, employing the enclosed volume as an element. In this manner, the pressure generated at the back of the speaker diaphragm (which otherwise performs its normal function) causes a compression or stiffness within the enclosure which acts on the area of the aperture and through which it subsequently oscillates in such a manner as to create an auxiliary source of sound. This auxiliary or driven source of energy is restricted to the relatively narrow band of frequencies in which it is wanted; in this case, below 60 cycles. Thus, one or more octaves of low frequency response is acquired. Jensen peri-dynamic speakers incorporating the bass-reflex system are illustrated in Fig. 18. At A, the loudspeaker opening is near

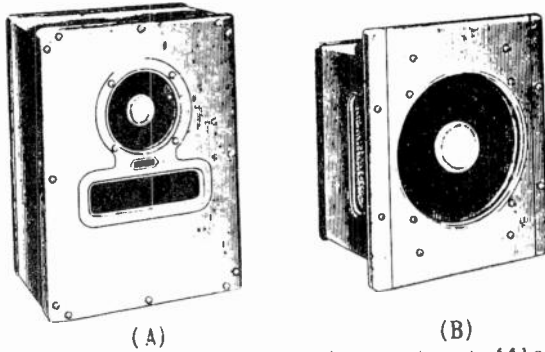

(A) (B)  
Fig. 18 Jensen Peri-dynamic speaker-baffles.  
(Courtesy Jensen Mfg. Co.)

the top center of the cabinet and the bass-reflex aperture is the rectangular opening directly beneath the loudspeaker. A slightly different design with the bass-reflex aperture on the side of the cabinet is shown at B in fig. 18.

5. **PHONOGRAPH PICKUPS.** A phonograph pickup is nothing more than a small, electrical voltage generator. A diagram showing the details of the construction of a simple pickup is given in Fig. 19. The needle follows the groove variations in the record and thus cause it to vibrate from side to side. By means of a set screw, the needle is fastened rigidly to the armature bar, which in turn is balanced in an intense steady magnetic field. The magnetic field is produced by the permanent magnet on which two pole pieces are attached. Two small coils, wound with very fine wire, are located in the space provided by the shaped pole pieces surrounding the armature bar, as shown at B in Fig. 19. Normally, with the arma-

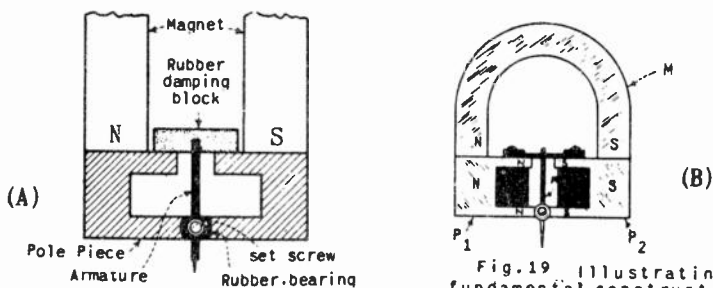

Fig. 19 illustrating the fundamental construction of a magnetic phonograph pickup.

ture bar in the center, the lines of force travel directly across the air gap between the pole faces of the permanent magnet. But, as the needle vibrates in the record groove, the armature bar alters the reluctance of magnetic path from the N to the S pole. The normal magnetic field being thus disturbed causes the lines of force to cut through the coil windings and generate a voltage therein. The direction of the lines of force as the needle moves, first to the right then to the left, is illustrated in Fig. 20.

The voltage normally generated in the coil winding due to the magnetic field changes is in the neighborhood of 1 volt (with a high impedance coil). This voltage is then fed directly to the grid of an amplifier tube or through a transformer whose secondary is connected to the grid. If the pickup is of the low-impedance type, it is advisable to couple the generated voltage into the grid circuit of the first A.F. amplifier through a transformer, but if of the high-impedance type, it is best to feed the grid directly. A high-impedance pickup may be designed to have a 25,000 ohm coil winding; however, this is not general practice, due to the increased tendency toward hum pickup and regeneration in the audio amplifier.

Ordinarily, present day high-impedance magnetic pickups have about 2,000 ohm's impedance and produce a peak output of approximately 1 volt. To realize this much voltage output, a strong permanent magnet must be used, and the magnetic armature must be relatively heavy. Low-impedance pickups have a coil impedance around 200 ohms. They generally give a better frequency response; but, their output voltage is much less, due to the smaller coil and lighter armature.

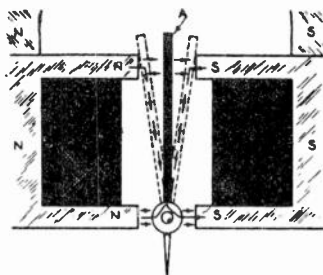

Fig. 20 Illustrating the needle movement produced by armature vibration.

As illustrated in Fig. 19, the lower end of the armature is pivoted in a rubber bearing and the upper or free end rests in a rubber damping block. A set screw holds the needle when it is inserted in the hollow lower end of the armature. Nearly all magnetic pickups are fundamentally the same in operation as the one just described. The only important difference is in the method of damping the armature's vibration.

The frequency response of a magnetic pickup is dependent primarily upon the character of the vibrating system which, in turn, is composed of the armature and the needle. All vibrating systems have a certain resonant frequency. In a phonograph pickup, this is generally between 3,000 and 5,000 cycles. To prevent an excessive response at these resonant frequencies, it is necessary to "dampen" the vibrating system. This damping is accomplished by the use of rubber buffers at the free end of the armature. These buffers serve another purpose in that they center the armature in the magnetic air gap. In the earlier magnetic pickups, these rubber buffers were not very elastic and, as a result dampened the vibrating system too heavily. This naturally caused the records to wear rapidly and materially affected the frequency response of the pickup. In modern pickups, the improved rubber buffers permit rather free movement of the armature, give a better frequency response and still dampen the resonant peak satisfactorily.

The details of a modern RCA pickup head are illustrated at A in Fig. 21. The magnetic assembly is one rigid piece with the horseshoe magnet solidly welded to the pole pieces. There is a centering spring attached to the armature to maintain proper adjustment and provide the damping effect on the movement of the armature. The frequency response is uniform over a rather wide range.

Referring to A in Fig. 21, the armature is shown in proper relationship to the magnet's pole pieces; that is, exactly centered. Whenever this centering adjustment has been disturbed, the screws A, B and C should be loosened and the armature clamp adjusted to

the point where the vertical axis of the armature is at right angles to the horizontal axis of the pole pieces and centered between them. This centering operation may be facilitated by inserting a small rod or nail into the armature needle hole, using it as a lever to test the angular movement of the armature. The limitations of the movement in each direction will be caused by the armature striking the pole pieces. Proper adjustment is obtained when there is equal angular displacement of the armature and adjustment rod or nail to each side of the vertical axis of the magnet coil assembly. The

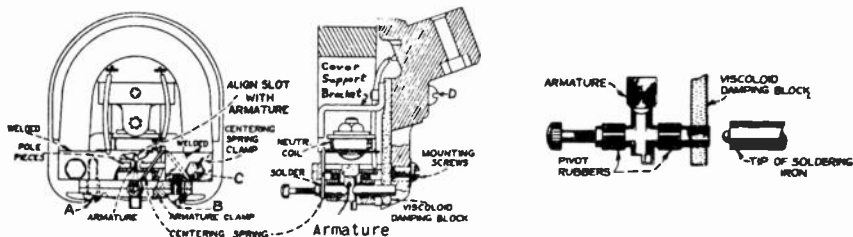

Fig. 21 (A) Details of the RCA viscoloid magnetic pickup.  
(B) Special-tip soldering irons (Courtesy R.C.A.)

screws A and B should then be secured, taking care not to disturb the adjustment of the armature clamp. Then place the pickup in a vise and secure the centering spring clamp by means of the screw C, allowing the centering spring to remain in the position at which the armature is exactly centered between the pole pieces. With a little practice, the correct adjustment of the armature may be readily obtained. The air gap between the pole pieces and the armature should be kept free from dust, filings and other foreign material which would obstruct the movement of the pickup armature.

The viscoloid block which is attached to the back end of the armature shank serves as a mechanical filter to eliminate undesirable resonances and to cause the frequency response to be uniform. This is called the "damping block." Should it be necessary to replace this damping block, it may be done by removing screw D and the cover support bracket from the mechanism and taking off the viscoloid block. The surface of the armature which is in contact with the viscoloid should be thoroughly cleaned with fine emery cloth. Then, insert the new block so that it occupies the same position as it did originally. Make certain that the block is in correct vertical alignment with the armature. The hole in the new viscoloid block is somewhat smaller than the diameter of the armature in order to permit a snug fit. With the viscoloid aligned on the armature, screw D and the cover support bracket should then be replaced. Heat should be applied to the viscoloid side of the armature so that the viscoloid block will fuse at the point of contact and become rigidly attached to the armature. A special-tip soldering iron constructed as shown at B in Fig. 21 will be very useful in performing this operation. The iron should be applied only long enough



to slightly melt the block and cause a small bulge on both sides.

Whenever there is defective operation due to an open or shorted pickup coil, this coil should be replaced. The method of replacement will be obvious upon inspection of the pickup assembly and by study of the cutaway illustration. Make sure that the new coil is properly centered with the hole in the support strip and glued securely in that position. It is important to readjust the armature as previously explained after reassembly of the mechanism. Only rosin core solder should be used for soldering leads in the pickup. The same type of solder should be used when necessary for soldering the centering spring to the armature.

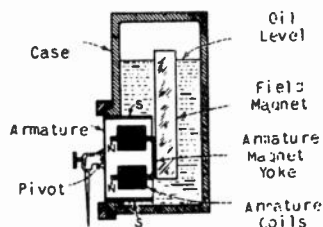
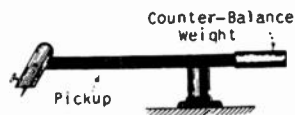

Fig. 22 Details of typical oil-damped magnetic phonograph pickup.

Another popular type of phonograph pickup is that which uses oil to dampen the armature vibration. A cross sectional view of an oil-damped pickup is shown in Fig. 22. Oil-damped pickups generally have low impedance coils and produce a low output voltage. The armature in this type of unit assumes the form of an oil-damped diaphragm attached to one of the poles of a permanent magnet. The other pole of the permanent magnet has two pole pieces attached to it around which are wound two coils. The needle, which moves in the record groove, is attached to the center of the diaphragm in such a manner that the diaphragm is caused to shift the magnetic flux from one pole to the other as the needle vibrates. An oil-damped pickup has the advantage of nearly completely eliminating diaphragm resonance without materially increasing the stiffness of the vibrating system which would tend to impair the low frequency reproduction.

If any type of phonograph pickup is to operate with good quality of reproduction, it is necessary that the weight of the needle on the record be as light as possible. Due to the relatively heavy weight of the permanent magnet employed, excessive record wear will

Fig. 23 Illustrating "counter-balance" to remove excessive pressure from needle point.



result and the noise or scratch output will be quite high. In nearly all pickup arms, a certain amount of weight is taken off the record by placing a counterbalance weight on the opposite end of the pickup arm. Ordinarily this weight is adjusted to permit a pressure of 4 or 5 ounces at the needle point. With this amount

of pressure, the needle will ride in the bottom of the record groove and will not be thrown out of the groove by the large amplitudes of vibration associated with the reproduction of bass notes. A counterbalance weight is illustrated in Fig. 23

6. **OUTDOOR SURVEYS AND INSTALLATIONS.** Among the numerous markets for outdoor sound installations are: ballparks, airports, cemeteries, athletic fields, bathing beaches, fairs, lawn fetes, memorial parks, picnics, playgrounds, political gatherings, race tracks, swimming pools, and steamship piers. Some installations will be permanently installed and will require a tremendous amount of audio power with an expansive speaker system. Others will be set up with portable equipment and rented to the customer for temporary use. Too often, one is prone to hurriedly set up a temporary job and get it to working without giving a second thought to the manner in which it works. Haphazard installations do not give satisfactory service and the usual result is that the job is given to someone else when the time comes for a second rental. There is money to be made in this field and invariably the conscientious man is the one who finds himself with most of the local business.

To be certain that your installation (whether temporary or permanent) will meet with the satisfaction of both the customer and the audience, always attempt to "distribute" the sound energy instead of merely "reinforcing" it. There is a discrimination here that is too frequently overlooked. "Sound distribution" means the even and equal dispensement of audio energy over a given area in such a manner that each part of that area receives the same apportion. Perfect sound distribution may not always be possible, but every attempt should be made to attain the ideal condition on each job. If the speakers are located such that those near the front of the area are irritated due to the extreme intensity of the sound, while those in the rear cannot comfortably discern the intelligence of the speech, then the sound is certainly not "distributed" but is merely "reinforced." "Sound reinforcement" pertains to the strengthening of the sound energy near its point of origination with no consideration given to the even distribution of that sound. The megaphone used by a cheerleader is a crude example. Obviously, the majority of sound installations require "distribution" and not "reinforcement", so every effort should be expended to attain that end. If the installation is to be used in close proximity to several other systems, then only "reinforcement" may be desirable so as not to cause undue interference. An example of this would be one of the many P.A. systems used by barkers down the midway of a large fair.

The average sound engineer is likely to under estimate the power required to give adequate coverage for outdoor applications due to the fact that much of his experience might have been with the application of indoor sound. Indoor sound systems do not re-

quire nearly the acoustical power to cover a given area as do outdoor systems; this being true because reverberation changes the behavior of indoor sound amplification completely.

For all outdoor installations, it is highly essential that directional loud speakers be used. This not only conserves the sound energy, but also prevents annoyance to people located at some distance from the particular event. With directional baffles and trumpets, it should be kept in mind that the source of sound is somewhat comparable to a large searchlight; the sound is projected from a directional loud speaker in much the same manner as a beam of light is projected over a long distance. The angle of sound projection is dependent upon the design of the baffle or horn, the same as the width of a projected light beam depends on the shape and location of the reflector.

The specifications of the manufacturer should always be consulted to ascertain the directional characteristics of a baffle or horn. For example, the R.C.A. Manufacturing Company gives the

Fig. 24 weather-proof turret projector for outdoor use. (Courtesy RCA)

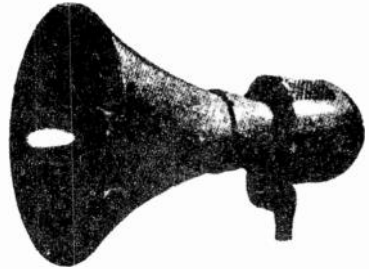

following specifications for the type MI 442b weatherproof sound projector illustrated in Fig. 24; Efficiency, 25%; distribution angle in all directions, 60°. For the type MI 4428 sound projector illustrated in Fig. 25 the following specifications are given: Ef-

Fig. 25 wide-angle reflection for indoor or outdoor use. (Courtesy RCA)

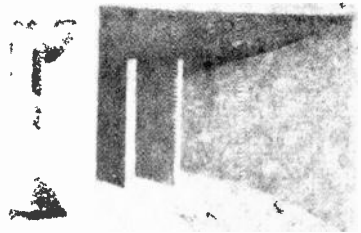

iciency, 25%; horizontal distribution angle, 90°; vertical distribution angle, 50°. Similar specifications may be obtained from the manufacturer for any type of speaker, baffle or trumpet designed for P.A. work.

When large cone-type dynamic speakers are used with exponential horns, the low-frequency spread is very wide, but the high frequency

output is not much more than a narrow beam. This is illustrated with the un baffled cone speaker shown in Fig. 26. If only speech is to be reproduced, the loss of low frequencies is actually desirable, but when music is being projected over a sound system, the

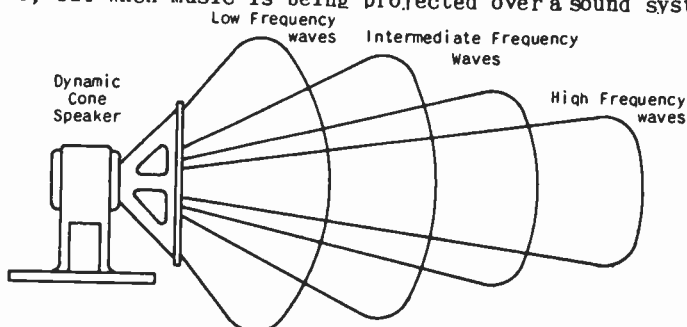

Fig. 26 Illustrating the production of sound waves from a cone-type dynamic speaker: Low frequencies are distributed near the cone, whereas the higher frequencies are projected outward in a narrow beam.

lows must be present for satisfactory quality of reproduction. Unless stated differently by the manufacturer, do not plan on a low frequency spread from a baffled speaker of more than  $60^\circ$ . The most directional horn and trumpet type speakers available have an average distribution angle of about  $99^\circ$ .

When planning the sound equipment necessary to effectively cover any outdoor event, the following must be determined:

1. The area over which sound must be audible.
2. Distance of loud speakers from the area.
3. Whether music as well as speech is to be reproduced.
4. Background noise level.

It has been determined that one watt of acoustic power per 1,000 square feet of area is required for good intelligibility of speech, providing the background noise is reasonably low. Knowing the area to be covered, the total acoustic power can then be computed. The usable acoustic power is approximately 25% of the electrical audio power applied to the voice coil of a well-designed loud speaker, so the electrical power output of the amplifiers may be computed, keeping in mind, of course, that the electrical power is to be utilized to the best advantage. The chart on the next page will be found helpful in determining the approximate figures.

For coverage of areas not given, the acoustic power can be found by multiplying the area in square feet by .001 and the electrical (amplifier) power determined by multiplying the acoustic power by 4. When using this chart, keep in mind that the power ratings are given assuming a low background noise level and that directional speakers are employed. If the sound system must override the noise of racing cars, or the crowd noise at beaches, picnics, fairs, etc., provision must be made by reserving ample electrical output power.

### APPROXIMATE POWER REQUIREMENTS

(Reasonably Low Background Noise)

Outdoor Area	Acoustic Power (Directional Speaker)	Electrical Power from Amplifier (Directional Speaker)
1000 sq.ft.	1 watt	4 watts
2000 sq.ft.	2 watts	8 watts
3000 sq.ft.	3 watts	12 watts
5000 sq.ft.	5 watts	20 watts
8000 sq.ft.	8 watts	32 watts
10,000 sq.ft.	10 watts	40 watts
20,000 sq.ft.	20 watts	80 watts
25,000 sq.ft.	25 watts	100 watts
50,000 sq.ft.	50 watts	200 watts
100,000 sq.ft.	100 watts	400 watts

Directional loud speakers should always be placed and directed so that they will cover the necessary area without producing feedback or undesirable acoustical effects such as echoes. Also, it is important to locate them where it will not be necessary to exceed their power handling capacity in order to cover the area. It has been found that when using even the larger speakers, it is desirable to limit the average electrical power to about 15 watts per unit to insure reasonable cone life. Thus, if 30 watts total electrical power are required, two speakers should be used, 3 speakers for 45 watts, etc.

For illustrative installations, let us first consider the most advisable method of covering a political gathering of about 1,000 people. Fig. 27 shows a plan view of a satisfactory set up. Here,

75 feet

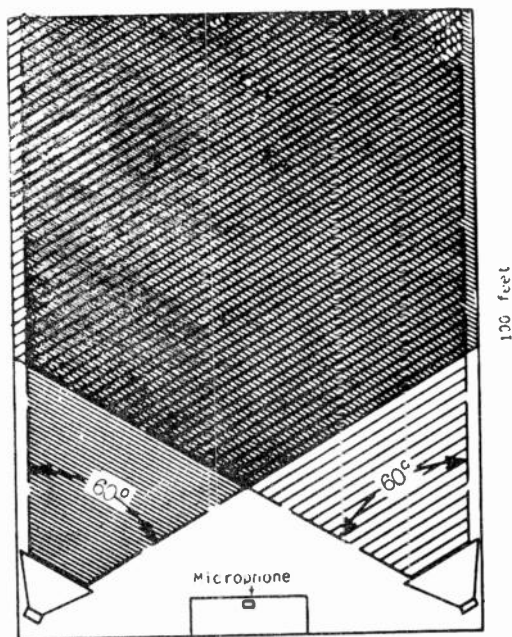

Fig. 27 Plan view of typical outdoor sound system.

the area is assumed to be 75 feet wide and 100 feet long. This is a total of 7,500 square feet or about 7.5 square feet per person. This is adequate to allow for chairs and aisles, after deducting the space occupied by the speaker's platform. A total of 7.5 acoustical watts will be necessary to satisfactorily cover the area and considering a speaker efficiency of 25%, a total electrical power of 30 watts should be used. Naturally, if the meeting is being held where automobile or street noises are unusually high, it is best to forestall dissatisfaction by employing an amplifier having a total output of about 50 watts.

Selecting the speakers is the next problem. Obviously, it will be best to use two speakers, one on each side of the platform. They should each be capable of continuously handling 15 watts and a peak of 25 watts without damage to the cones. After drawing the area to scale (as in Fig. 27), it is found that directional baffles having a 60° spread will be very satisfactory. These units should be placed on either side of the platform and pointed exactly as illustrated in Fig. 27. With this arrangement, those outside the selected area (to the right or left) will not be annoyed as much by the sound system and still it will cover the crowd very effectively. Notice too, that the "crossover" of the two speaker beams takes

75 Feet

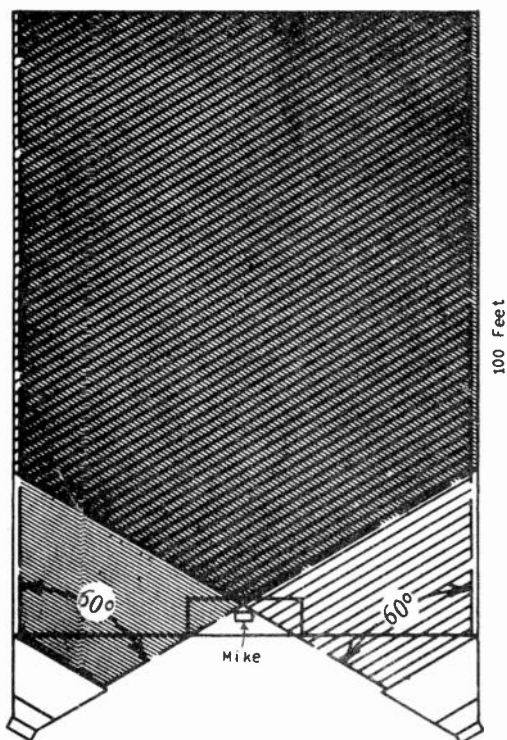

Fig. 28 Incorrect method of speaker placement. Here, the speaker beams are directed toward the microphone and acoustic feedback is certain to result.

place about 15 feet in front of the microphone. This helps to prevent feedback. The flared end of each of the speakers should be in either a direct horizontal line or slightly in front of the microphone; otherwise it is unlikely that full coverage will be possible without excessive feedback. Fig. 25 illustrates why this is true. Here, the speakers are behind the microphone and the crossover of the speaker "beams" takes place directly at the microphone position. This is certain to cause feedback, so such a set up is not satisfactory. Referring again to fig. 27, the two speakers should be elevated at least 15 feet above ground level. This is necessary to permit adequate sound projection and also to prevent excessive volume near the front of the audience. The vertical directivity of the speakers is of great importance in this respect. The baffles should be designed in such a manner that the sound is not allowed to drop directly toward the front of the audience, but rather about  $\frac{1}{3}$  to  $\frac{1}{2}$  the way back. Those seated near the platform will be able to hear the speech directly or from the "spillage" beneath the two baffles. A side view of fig. 27 is shown in Fig. 29; here it is evident that the vertical distribution angle of the baffle should be adjusted to about  $25^\circ$  or  $30^\circ$  with the horizontal. Such an angle may be secured by tilting the directional baffle slightly upward, if it does not have the proper downward flare.

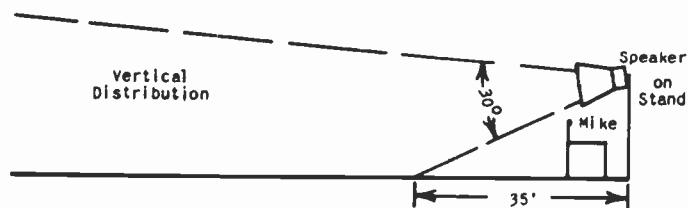

Fig. 29 illustrating the vertical distribution angle of a trumpet-type projector.

All these features of speaker and baffle selection, as well as the exact angle of direction and tilt should be thoroughly worked out on paper before the installation is made. Then, if the system is bothered with feedback or inadequate coverage, it will be necessary to resort to experimentation. Always try to avoid experimentation if at all possible because it is not complimentary of one's ability to have a lot of trouble "on the job." If the above mentioned calculations are made, the system should work very satisfactorily unless individual problems prevent.

The majority of small outdoor installations can be calculated and installed in a manner very similar to that just explained. Differences may arise in the placement of the speakers in order to obtain the most effective distribution of sound energy, however, these problems may be treated intelligently by sketching the area to scale and then, knowing the directional properties of the baffles, determine the most logical location and angular position of each.

A large outdoor installation may be handled in a manner similar to the smaller ones; that is, the problems of coverage, electrical power and speaker placement are practically the same. For example, let us analyze a typical ball park installation. A schematic dia-

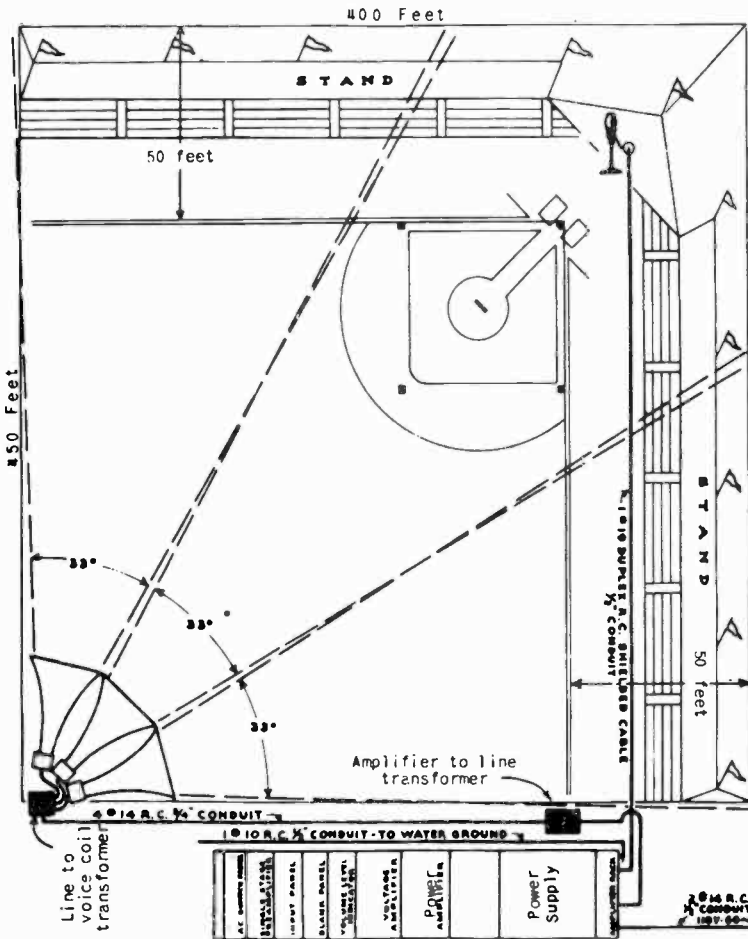

Fig.30 Typical athletic or baseball park sound installation.

gram of a large athletic field or base ball park is shown in Fig. 30. The overall dimensions of this park are given as 450 x 400 feet, a total of 180,000 square feet. Not all of this area is to be covered by the sound energy, in fact it is desirable to keep the sound off the field as much as possible so as not to annoy the players. By using very directional baffles, mounted high above the ground at the far corner of the field, the sound may be projected over the field into the grandstand audience. If the speakers are at least 50 feet above the ground, the spillage on the field will be negligible and nearly all of the original sound energy will be available to the patrons in the stands. So, to calculate the area that must be covered, let us subtract the area of the field itself from the total area of the park. From Fig.30, the field area is



seen to be 400 x 350 feet, or 140,000 square feet. Deducting this from the park area, there is 40,000 square feet of grandstand space to be covered at the proper volume level.

Now, using the same method as before (refer to chart on Page 27, the acoustic power necessary is 40 watts, and the electrical power is 160 watts. For this amount of electrical power to properly cover the grandstand area, it is understood that the noise level is relatively low; the speaker efficiency is 25%, and elevated directional baffles are used.



Fig. 31 A dynamic driving unit with the polarity of the voice and field coils marked.

Three large baffles, each having a horizontal directivity of 99° are mounted as shown in Fig. 30. Each of them will be required to handle  $\frac{1}{3}$  of the total electrical power, or about 55 watts each. A single cone-type speaker cannot continuously handle this amount of electrical power, nor is it advisable to expend that much energy in the voice coil of a single horn-trumpet driving unit. A typical dynamic trumpet driving unit is shown in Fig. 31. These units are generally rated between 15 and 25 watts capacity. A driving unit-trumpet assembly is shown in Fig. 32. In the ball park installation, each of the three trumpets is required to handle about 55



Fig. 32 Driving unit with trumpet attached.

watts so it is best that the total power be divided among several driving units on each trumpet. Trumpets are designed to accommodate 2, 3, or 4 units; a four-unit trumpet is illustrated in Fig. 33. The 55 watts total power could be divided between 3 units; each handling about 20 watts, or 4 units could be used, in which case, only 15 watts dissipation in each would be necessary. To be on the safe side, it is advisable to install the four-unit type. Then, you are assured that the initial expense will be final, and the system will not be inoperative for speaker repairs. If this decision is accepted, a total of 12 dynamic driving units (four for each trumpet) are purchased, then the three horns directed from the far corner of the park as shown in Fig. 30.

An alternative speaker arrangement for the ball park would be to use several cone-type dynamics distributed at various points throughout the grandstand proper. In this event, about 12 large

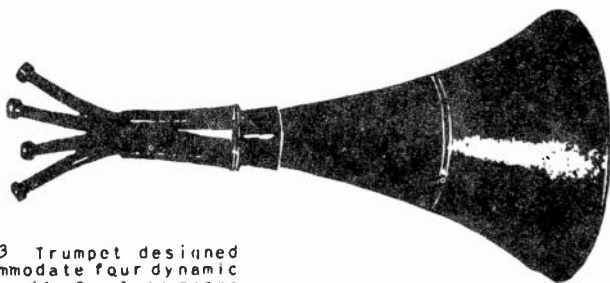

Fig. 33 Trumpet designed to accommodate four dynamic driving units for long range sound projection.

speakers would be used, located systematically so as to evenly distribute the sound energy. The main objection to this method is that with so many speakers in a concentrated area, bad echo effects are quite probable. Upon attempting to correct the echoes, it is likely that a considerable portion of the sound will be wasted, then inadequate coverage may result. All in all, the fewer speakers used the better, and since sound can be projected easily over a distance of 500 feet, the method suggested in Fig. 30 is considered more satisfactory.

To complete the discussion on the installation in Fig. 30, the microphone is shown located in the enclosed press-box on top of the grandstand. It is connected to the amplifier rack (also in the press-box) where it feeds directly in to a pre-amplifier. Additional amplifiers, controls, volume level indicator, and power supplies are also included in the amplifier rack. The microphone is connected to the rack with a #19, two-wire, rubber covered, shielded cable enclosed in  $\frac{1}{2}$ " conduit. The amplifier rack is grounded to the water system. Field supply units are provided. An output matching transformer delivers the A.F. power to a transmission line leading to the speaker location. Large wire in a heavy conduit is used for this line. An additional matching transformer is used at the speaker location to couple from the line to the voice coils of the 12 driving units.

This entire system may be represented by the simple diagram shown at A in Fig. 34. Here, all the voltage and power amplification is performed at the microphone location, then the total A.F. power is transmitted through lines to the speakers. This method has the disadvantage that an appreciable loss of power is apt to occur in the long transmission line. A second arrangement is illustrated at B in Fig. 34. This is the reverse of A; it corrects the disadvantage of transmission line loss, but enters a second defect in that the amplifier must be remotely controlled and so is rather inconvenient. The long microphone line may also result in excessive noise. The best method of all is illustrated at C in Fig. 34. The microphone, pre-amplifier and voltage amplifiers (driver) are located at the microphone position, then a transmission line is employed to connect to the power amplifier, which is located at the speakers. Thus, all controls are convenient and the trans-

mission level, although low, is high enough to be above the noise level of the line.

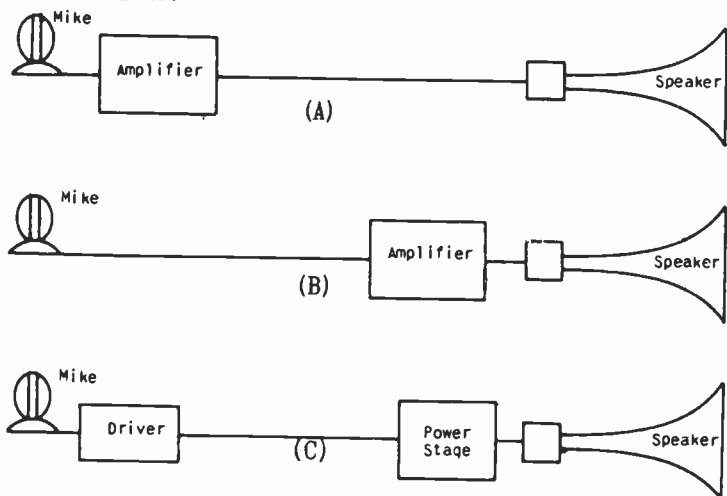

Fig. 34 (A) Equipment set-up with amplifier at the microphone and long lines to the speaker.  
 (B) Equipment set-up where the amplifier is at the speaker.  
 (C) Most satisfactory method of installing equipment where long lines are concerned. The voltage amplifier (driver) is at the microphone and the power stage at the speaker end of the line.

7. **AUDIO TRANSMISSION LINE IMPEDANCES.** Audio power should be transmitted over long wire lines at an impedance between 200 and 600 ohms. There are several reasons for selecting a value within these limits. If a low impedance line (8 or 16 ohms) is used, the current through the line will be very high. This sets up a strong electromagnetic field around the wires and may result in feedback or cross-talk. Also, an appreciable voltage drop occurs through the resistance of the line when the current is high. On the other hand, if the line impedance is made excessively high, (above 5000 ohms), the current is low, but the voltage across the line is high, which invariably leads to undesirable capacitive effects. The higher audio frequencies will be by-passed and lost through this line capacity.<sup>1</sup>

It is common practice to compromise and use audio line impedances between 200 and 600 ohms for best results.

8. **VOICE COIL CONNECTIONS.** The voice coils of dynamic speaker units may be arranged in series, parallel, or series-parallel combinations in order to match the secondary of the amplifier's output transformer. If a single speaker is used, its voice coil is connected directly across the taps on the transformer secondary which have an impedance marking equal to that of the voice coil. Impedance matching here is a very important item, because it determines the maximum amount of audio power which will be obtained from

<sup>1</sup> Long high-impedance microphone lines overcome this defect by using a fine wire through the center of a large low-capacity shield.

the amplifier and also the percentage of harmonic distortion in the output.

As will be recalled from previous study, the maximum undistorted power output is obtained when the load impedance in the plate circuit of the power tube, or tubes is equal to twice the internal plate resistance. The primary impedance of a transformer is a direct function of the secondary load; hence, any change in the secondary impedance connections will change the power output and distortion characteristics of the amplifier. For this reason, it is of utmost importance that the proper load (in ohms) be connected across the secondary.

For example, if the output transformer is designed such that the power stage in the amplifier will be properly loaded when an 8 ohm load is connected across the secondary, then a single voice coil, having an impedance of 8 ohms may be connected directly across it. Also, it is equally satisfactory to connect two voice coils, each having an impedance of 16 ohms in parallel across the transformer secondary. Again, two 4 ohm voice coils may be connected in series and across the 8 ohm secondary winding. In all these cases, the total impedance of the voice coils is 8 ohms and so exactly equals the secondary load necessary to work the power tubes correctly.

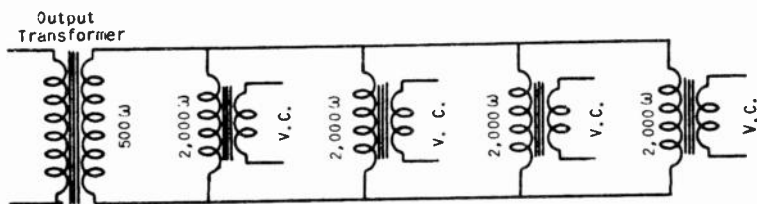

Fig. 35 Method of coupling 4 speakers to a 500 ohm secondary, using a separate transformer for each speaker. The primary impedance of each is 2,000 ohms, and the effective Z of the parallel combination is 500 ohms.

Next, let us assume that the output impedance of the amplifier is 500 ohms and it is desired to connect 4 speakers to it, working each at the same volume level. A satisfactory parallel arrangement of 4 coupling transformers to the voice coils is shown in Fig. 35. Here, a separate transformer is used to couple from the 500 ohm line to each voice coil; such an arrangement is sometimes necessary to operate remote speakers.

In multiple-speaker installations, it is frequently necessary to operate some speakers at a higher or lower volume level than others. Such might be the case in schools, churches, auditoriums, etc. The common practice, familiar to most sound men, is to match the amplifier output with a suitable number of speakers of different sizes, but all of the same impedance, and all wired in parallel. Attenuators are then connected across the smaller speakers to cut down their volume. This method is crude, wasteful of power and calls for an amplifier much larger than would otherwise be necessary. The multiplicity of loud speakers (and universal output transformers) now on the market makes possible a more efficient method

of securing the same result. The following is a treatise of the subject by the engineering department of the Wright De Coster Manufacturing Company.

"When a large number of speakers are used in a sound installation and it is desired to divide the power so that greater amounts of energy are delivered to some speakers than to others, it is necessary to have those speakers which are to receive a greater amount of energy of a much lower impedance than the other speakers in the circuit. If it is desired to have the level of these speakers approximately 3 db. above the level of the others, it is necessary to deliver to them twice the energy. Assuming that the voltage across the total load remains the same, then the current through these higher level speakers must be twice what it is through the low level speakers. This means, of course, that the impedance must be exactly half.

Now if it is desired to run other speakers on the same line at levels of 3, 6, 9, or 12 db. above the lowest level speakers, then the impedance must be correspondingly low so as to consume a greater amount of energy. The table following will give the percentage of impedance that the high level speakers must be of the low level speakers in order to be at a plus level corresponding to the db. tabulation.

3 db. - -	50%
6 db. - -	25%
9 db. - -	12½%
12 db. - -	6¼%

"It will be noted that for each 3 db. rise in level, the impedance of the preceding value is divided by two. Therefore, this table can be continued indefinitely in order to obtain higher levels. Each rise of 3 db. corresponds to a power level of double the preceding value.

"In calculating the resulting impedance of a number of unlike impedances in parallel, the following equation is utilized.

$$Z \text{ (Total)} = \frac{1}{\frac{1}{Z_1} + \frac{1}{Z_2} + \frac{1}{Z_3} \dots, \text{ etc.}} \quad \text{(A)}$$

"If a number of like impedances are in parallel, the resulting impedance is the impedance of a single speaker divided by the total number in parallel.

"If a number of like or unlike impedances are in series, then the resulting impedance is the sum total of all the impedances."

"It is usually unwise to have speakers used in a series circuit because if a single unit of the series develops an open circuit, the entire group becomes inoperative, resulting in not only inoperation of the system, but also a great likelihood of breakdown of the output transformer in the amplifier.

"An example of a system wherein the power division is greatly different and the method of calculating the resulting impedance is illustrated as follows:

"Assume that a school system is to have 25 rooms in which speakers are to be operated at a level of one watt. Also, each of these speakers is to be 500 ohms in order to utilize standard 500 ohm constant-impedance volume controls. The resulting impedance of twenty-five 500 ohm speakers in parallel would be 20 ohms. Now suppose that there are to be two speakers in the auditorium, each one of which is to be operated at a level of 9 db. above the class room speakers. We find from reference to the foregoing table that each of these speakers would have an impedance of  $62\frac{1}{2}$  ohms.<sup>1</sup> The impedance of the two speakers in parallel would be 31.25 ohms. Now also suppose that there are to be two speakers on the athletic field, each of which is to be operated at a level of 12 db. above the class room speakers. This would mean that each of these speakers would be 31.25 ohms<sup>2</sup> and the two of them in parallel would be 15.6 ohms approximately. Now in order to find the total impedance of all of these speakers in parallel, it is necessary to find the reciprocal of the sum of the reciprocals as in formula A. The reciprocal of the class room speakers we find would be .05. The reciprocal of the auditorium speakers would be .032. The reciprocal of the athletic field speakers would be .064. The sum of these would then be .146. Now the reciprocal of .146 would be 6.85. This means that the amplifier would have to have an output transformer designed to work from the plates of the output tube into a load impedance of 6.85 ohms.

"In order to calculate the power necessary for operating each speaker at its proper level, assuming that the class room speakers are to be operated at one watt each and there are 25 of them, this would mean 25 watts, of course. Each one of the two auditorium speakers is operated at a level of 9 db. above the level of the class room speakers so the power level to each speaker would be 8 watts and for the two speakers, of course, it would be 16. The 8 watts for each speaker is determined from the fact that each time the electrical power is doubled, the db. increase is 3 times. A 3 db. increase results from increasing the power from 1 to 2 watts; 3 db. from 2 to 4 watts; and 3 db. from 4 to 8 watts. A level increase of 9 db. from 1 watt thus requires an electrical power increase to 8 watts.

"The two athletic field speakers being operated at a level 12 db. above the class room speakers would mean that the power delivered to each of them would be 16 watts or a total of 32 watts. Now if the sum of these three powers is taken, it is found that an amplifier necessary to operate a system of this type has to have an output of 73 watts."

This method of determining the output transformer impedance and amplifier power represents a real saving, and therefore a lower price that will result in a sale against competitors who resort to the use of attenuators across the smaller speakers. Over 100 watts of audio power would be required if such calculations were not carried out, and also the cost of the attenuators would have to be added. Still further, with the arrangement just de-

<sup>1</sup> 62.5 ohms is 12.5% of 500 ohms.

<sup>2</sup> 31.25 ohms is 6.25% of 500 ohms.

scribed, impedances match perfectly throughout, while with attenuators they do not, and to secure the same accuracy of impedance match, pads would have to be used instead of potentiometers, at even greater cost.

9. **SPEAKER PHASING.** When two or more loud speakers are operated in the same vicinity, it is necessary that their voice coils and cones be "phased". By "phasing" is meant connecting the voice coils in such a manner that the cones or diaphragms operate in exact synchronism; that is, they move outward and inward in perfect coordination. Let us see why such a procedure is necessary.

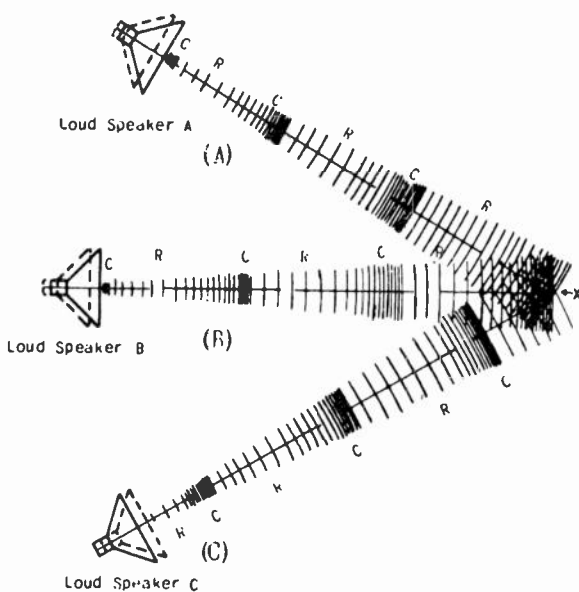

Fig. 36 Illustrating the necessity for "phasing" speakers when two or more are used to cover the same area.

In Fig. 36, three speakers are being used, and for illustration, we shall assume that they are placed so that a listener at point X hears the sound energy from each of them. The speakers are designated as A, B, and C. Understand that it is not necessary for them to be purposely pointed as shown in the figure, because the same result is apt to occur due to overlap and cross-over of the individual speaker beams.

For explanation, let us assume that the voice coils of speakers A and B are connected properly, but that of speaker C is not "in phase" with them. At a given instant, let us say the cone of speaker A is moving forward and producing a compression of the air molecules directly in front of the cone. Since speaker B is in

phase with A, its cone is also moving forward, and producing a compression. But speaker C is not connected the same as A and B, so its cone is moving backwards and producing a rarefaction. The movement of C is therefore "out of phase" with that of A and B.

The sound waves produced by each of the three speakers travel outward from the vibrating cones at the same speed, so let us see what the effect will be when they reach the listener at point X. At the time of arrival, a compression is being produced by the sound energy from A and B. Since these two are together, they reinforce each other and to the ear of the listener, the volume is additive. The energy from speaker C arrives at the listener as a rarefaction, therefore it tends to partially neutralize the compressions produced by speakers A and B. This, in turn, decreases the intensity of the sound. Now, at the instants of rarefaction from speakers A and B, there will be a compression from C, so again the total sound energy at point X is partially neutralized instead of being equal to the sum from the three speakers. Obviously, speaker C is creating a detrimental effect due to its out of phase condition, so it should be connected to operate in synchronism with A and B.

Dead spots through an audience are frequently a result of improper speaker phasing, which causes complete cancellation of the sound waves. The problem of distortion is equally as serious. At the higher audio frequencies, the mode of vibration of the cone does not exactly follow the "plunger" action, which is descriptive of the low frequency production, and severe distortion of the resulting sound is certain to occur at numerous spots if the speakers are not properly phased.

The method of phasing dynamic speakers is very simple. Most of the dynamic driving units (such as shown in Fig. 31) have the voice coil polarities marked; the positive side is generally painted red and the other post, black. When connecting these voice coils in parallel, connect all the reds together and all the blacks together. If it is a series arrangement, the red of one unit connects to the black of the next, etc. The field windings are generally marked also, so they should be connected the same as the voice coils. Reversing the field polarity will also throw a speaker cone out of phase.

Ordinarily the polarity of the voice and field coils are not marked by the manufacturer on cone type dynamic speakers. To phase these speakers, a small  $4\frac{1}{2}$  volt C battery (or a  $1\frac{1}{2}$  volt dry cell) may be connected either in parallel or in series with the main secondary winding of the output transformer which feeds all of the voice coils. At the moment of contact, all of the speaker cones should move in or out together. The direction of motion may be determined by placing the fingers lightly on the cone of each in turn as the voltage is applied in the same direction each time. If the cone of one speaker moves in, while the others move out, then reverse the voice coil connections on that speaker. If there are only two speakers on the system, the connections to either voice coil may be reversed.

16. DETERMINING THE POWER OUTPUT OF AN AMPLIFIER. The amplifier power ratings specified by various manufacturers are frequently



misinterpreted. The usable power from any amplifier is only that which is delivered directly to the voice coil or coils connected across the secondary of the output transformer. Then, too, the desirable amount of the usable power is limited to that containing less than 6% combined harmonic distortion. So, when the power output rating of an amplifier is given, one should be aware of these facts and be capable of making deductions if necessary.

The maximum undistorted power output is secured from any power stage when the plate load impedance is equal to twice the plate resistance of the power tube or tubes. For example, when the push-pull power amplifier shown in Fig. 37 is loaded with a resistance equal to twice the combined internal resistance of the push-pull tubes, the maximum undistorted power output will be secured. This type of load does not represent a practical circuit, because in all cases, a push-pull power stage is loaded with an output transformer wherein the reflected secondary load determines the primary impedance. With the inductive transformer windings, the load will not remain constant at all frequencies, so again, the pure resistance load shown in Fig. 37 is of little practical value insofar as determining the actual operating characteristics of the amplifier. For these reasons, when inspecting the data supplied by a manufacturer as to the power output and distortion content of an amplifier, determine if possible, the conditions on which such data is based. Should it be found that a pure resistive load is assumed, then the characteristics are of little value and should not be accepted as an accurate representation of its performance.

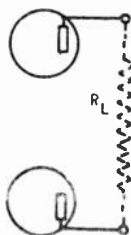

Fig. 37

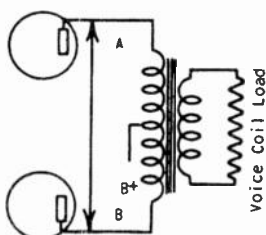

Fig. 38

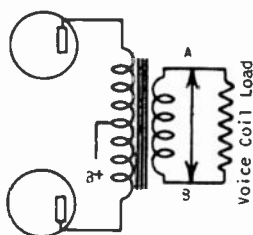

Fig. 39

Fig. 37 (left) Push-pull stage assuming a pure resistance load. Power calculations using a resistance load are of little practical value.

Fig. 38 (center) Push-pull power stage with output transformer serving as plate load impedance. Measurements across A and B do not take the characteristics of the output transformer into consideration.

Fig. 39 (right) Push-pull power stage with output transformer serving as plate load impedance. Measurements across A and B are truly representative of the amplifier's operation.

More frequently, manufacturers rate their amplifiers on the basis of measurements made across the primary of the output transformer with a resistive load across the secondary that will reflect the proper primary load impedance to the power stage. A measurement of this kind is made across points A and B in fig. 38. These data also are not truly accurate figures; at least, they should not be accepted as positive indications of the operation that will

be secured. The reason, of course, lies in the fact that the complete characteristics of the output transformer are not taken into consideration. At best this transformer will never have an efficiency of power transfer in excess of 80%. Consequently, when the power output of an amplifier is rated as 30 watts, plate-to-plate, the maximum usable power delivered to the voice coils of the speakers cannot be more than 80% of 30 watts, or 24 watts. Also, the distortion percentage may not be the same on the primary side of the output transformer as on the secondary side, so allowance should be made for the qualitative characteristics of the output transformer.

By far the most accurate amplifier data is that specified with reference to the secondary side of the output transformer; that is, directly across the voice coils of the speakers. When the power and distortion characteristics are measured across the secondary (points A and B in Fig. 39), the purchaser is assured that the manufacturer's specifications are exactly those which will be obtained under actual operating conditions in the field. Power measurements made across the secondary take into consideration the efficiency of the output transformer. Also, the distortion specifications are truly accurate because the audio power available on the secondary side is not ordinarily fed through additional transformers,

#### GENERAL POWER REQUIREMENTS FOR SOUND INSTALLATIONS

The following data serves as an approximate guide for power requirements.  
Deviations may be necessary in specific installations.

APPLICATION	6 Watts	12 Watts	24 Watts	50 Watts	200 Watts
AIRPORTS				*	*
ALL OPEN AIR APPLICATIONS WHERE HIGH POWER IS REQUIRED					*
AMUSEMENT PARKS			*	*	
ARMORIES				*	
ATHLETIC FIELDS				*	*
AUCTION ROOMS	*				
AUDITORIUMS			*		
AUDITORIUMS (LARGE)				*	
BALL PARKS				*	*
BALLYHOOD SYSTEMS	*				
BATHING BEACHES					*
BEER GARDENS		*			
BEER GARDENS (SMALL)	*				
BOWLING ALLEYS		*			
BOWLING ALLEYS (SMALL)	*				
BUS STATIONS		*	*		
BUS STATIONS (SMALL)	*				
CEMETERIES				*	
CHURCHES			*		
CHURCHES (SMALL)		*			
CONVENTIONS				*	
COUNTRY CLUBS			*		
COUNTER DEMONSTRATORS	*				
DANCE HALLS			*		
DANCE STUDIOS			*		
DEPT. STORES			*		
DEPT. STORES (SMALL)		*			
DRUG STORES	*				
FAIRS AND EXPOSITIONS					*
MOTEL BALL ROOMS			*		
INDUSTRIAL PLANTS				*	
LUNCH ROOMS	*	*	*		
LODGE ROOMS			*		
MASS MEETINGS					*
NIGHT CLUBS		*	*		
ORCHESTRAS			*	*	
RACE TRACKS				*	
RAILROAD STATIONS		*	*		
RAILROAD STATIONS (SMALL)	*				
RESTAURANTS		*			
RESTAURANTS (SMALL)	*				
SHIPS			*	*	*
SKATING RINKS			*	*	
SOUND TRUCKS		*			
SPORTS ARENAS				*	
STADIUMS				*	*
S. S. PIERS			*	*	*
TRAFFIC CONTROL		*	*		
WEIGHING STATIONS	*				
WINDOW DEMONSTRATORS	*				

Courtesy "Service"

but rather applied directly to the voice coils of the dynamic reproducers.

On several occasions, the sound engineer finds it necessary to compute the power output and percentage distortion of an amplifier. These are not so easily determined with the equipment available in the average shop. The power output can be determined with relative ease, but an accurate distortion measurement is impossible unless one has access to a commercial Harmonic Analyzer, such as that manufactured by the General Radio Company. A power output measurement alone is not wholly acceptable without at least some idea as to the distortion content. If no other means is available, an oscilloscope pattern of the output voltage may be used to indicate when the distortion attains a perceptible value. The equipment set-up for collecting these data is illustrated in fig. 40.

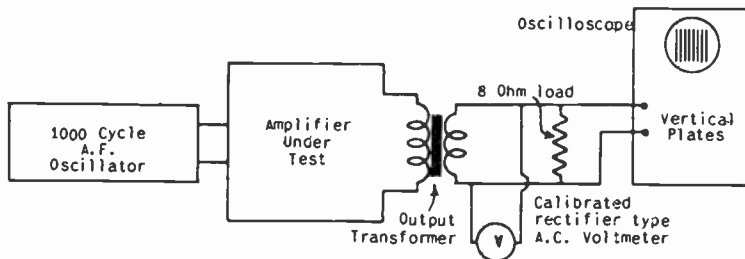

Fig. 40 Block diagram of equipment set-up for measuring the power output of an audio amplifier. The oscilloscope serves as a distortion indicator.

A 1,000 cycle audio signal is fed into the amplifier under test. Some amplifiers are tested at 400 cycles: either is satisfactory. The audio signal must be free from waveform distortion. The secondary of the output transformer is then loaded with the proper size resistance. In case the secondary is tapped, use the taps across which the actual load will be connected. For example, if the total secondary load (voice coils) has an impedance of 6.75 ohms, connect a resistance of this value across the 6.75 ohm taps on the secondary; if the secondary load is a 500 ohm line, connect a 500 ohm resistor across the 500 ohm secondary taps, etc. In this respect, it is well to state that a slight mis-match is not of much consequence; but the mis-match should be made in the direction of a higher impedance rather than a lower one. A mis-match of over 20% is not advisable in any case.

In fig. 40, the secondary load impedance is assumed to be 8 ohms. To measure the secondary voltage, a calibrated rectifier type AC voltmeter is placed across the secondary and to indicate distortion, the vertical plates of an oscilloscope are connected directly across the load resistor. With all the equipment turned "on", adjust the volume control of the amplifier full on and attenuate the output of the audio oscillator. Then adjust the sweep circuits in the oscilloscope to produce about 4 pure sine wave cycles on the screen. Now, increase the 1,000 cycle input voltage (keeping the oscilloscope pattern the same height with vertical amplifier control) until the image begins to show a deviation from

pure sine wave form. Read the AC voltmeter and compute the power output of the amplifier by using the formula:

$$P.O. = \frac{E^2}{R}$$

Where: E is the R.M.S. voltage across the secondary  
R is the impedance of the secondary circuit.

For example, if the maximum AC voltage reading that can be obtained without waveform distortion on the oscilloscope is 25 volts, then the experiment has indicated that the maximum undistorted power output of the amplifier is 78.1 watts; found as follows:

$$P.O. = \frac{25^2}{8} = \frac{625}{8} = 78.1 \text{ watts.}$$

11. ACOUSTICS. A working knowledge of this subject is essential to the well-informed sound engineer in order that he may intelligently survey and install indoor sound systems. It deals primarily with the ability of various materials or objects to absorb or reflect sound and the effect of such occurrences on the distribution of sound in a hall, auditorium, theatre, etc. We are all familiar with the difference that exists in sounds when heard in an empty room and when the same sound is heard in the same room after it is heavily draped, or filled with furniture. The reason for this difference is a problem in acoustics.

1000 cu. ft.	volume requires	.84	seconds
2000	"	.92	"
4000	"	1.00	"
10,000	"	1.13	"
25,000	"	1.27	"
40,000	"	1.35	"
100,000	"	1.52	"
250,000	"	1.72	"
400,000	"	1.82	"
700,000	"	1.96	"
1,000,000	"	2.05	"

Fig. 41 Optimum reverberation time in seconds for various volumes.

Previously we have compared the projection of sound with the emission of a beam of light from a searchlight. It is possible to reflect light from prepared surfaces and mirrors and it is also true that sound waves are reflected when they strike bare walls or hard surfaces. In fact, any object except an open space will reflect sound waves to a certain extent, some more than others, of course. As a result of these reflections, sound waves do not die out immediately upon striking a surface, but rather continue to subsist in the enclosed space for a definite length of time until they decay to a negligible value. Should this period of decay be prolonged in excess of a certain time, the sound waves interfere with each other in such a manner that speech or music may become unintelligible. The term applied to this repeated reflection of sound is "reverberation" and the number of seconds (or fraction

thereof) required for the produced sound waves to decay or die out is called the "reverberation time."

If the volume and contents of a room are such that the reverberation time is long, the excessive and continuous reflections cause difficult intelligibility whereas, if the room is heavily "damped", there will be little or no reverberation and the sound appears unnatural or "dead." Obviously, there is an optimum reverberation time for any definite volume of enclosed space (room or hall) wherein produced sound waves reach the ears of the listener in a natural and pleasant manner. By experimentation, the optimum reverberation time has been determined to vary with the cubic volume of a room in accordance with the chart shown in Fig. 41.

After knowing the optimum reverberation time, it is next necessary to determine the actual reverberation time and thereby find if the room or hall is too "live" or too "dead". The most accurate and acceptable work on this problem was performed by Wallace Sabine and, as a result, we have available "Sabine's formula". It is:

$$T = \frac{.05 \times V}{a}$$

T is the reverberation time of a room or hall in seconds.  
 Where: .05 is a constant used in all calculations  
 V is the volume of the room in cubic feet  
 a is the total acoustic units of absorption in the room.

When using this formula, it is necessary to determine only two factors, the total volume in cubic feet and the number of acoustic units of absorption. The volume is found by multiplying the width, length and height of the room or hall.

To find the absorption units, it is necessary to know the "absorption coefficient" of each kind of material and each object

COEFFICIENTS OF ABSORPTION

	Units per Square Foot		Units per Square Foot
Open window	1.00	'Acousti-Celotex, Type BB,	
Plaster	.025 to .034	painted or unpainted	.70
Concrete	.015	Acousti-Celotex, type B,	
Brick set in Portland	.	painted or unpainted	.47
Cement	.025	Sanacoustic Tile, 1" rock	.
Marble	.01	wool filler	.74
Glass, single thickness	.027	Nashkote, Type A, 2"	
Wood sheathing	.061	thick	.27
Wood, varnished	.03		
Cork tile	.03	(Individual Objects)	
Linoleum	.03	Audience, per person	4.2
Carpets	.1 to .25	Plain Church pews linear	
Cretonne cloth	.15	ft.	.18
Curtains in heavy folds	.1 to .5	Upholstered Church pews,	
Hairfelt 1/4" (Johns-		per linear ft. up to 1.6	
Manville)	.31	Plain Plywood auditorium	
Hairfelt 1" (Johns-		chairs, each	.24
Manville)	.59	Part upholstered chairs	1.6
Flaxlinum 1/4"	.34	Completely upholstered	
Sabinite Acoustical		chairs	3.5
Plaster	.21		

contained in the hall. These coefficients of sound absorption have been determined for practically all materials and each square foot is rated by comparison with one square foot of open window space, which is accepted as 100% absorptive, and therefore has a coefficient of one. The preceding table lists the acoustic units of absorption per square foot for most of the common materials and objects.<sup>1</sup>

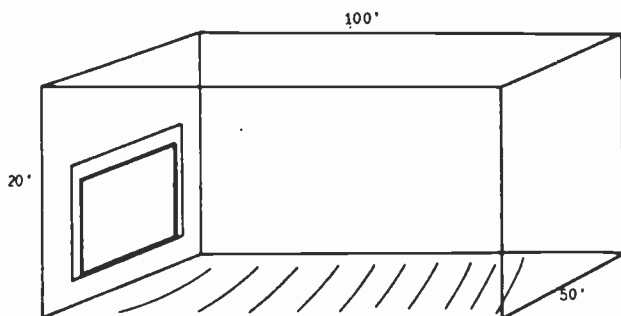

Fig. 42 Rectangular room to be used for sample calculation.

Let us assume the sample calculation of a rectangular theatre one hundred feet in length, fifty feet in width and average twenty feet in height, as shown in Fig. 42. The volume would be:

$$(100) \times (50) \times (20) = 100,000 \text{ cu. ft.}$$

The reverberation time of the building is a function of the volume and number of absorption units present.

Let us tabulate all absorption present in the above original condition and from that data calculate the existing time, compare it with the optimum time required for good hearing and then consider all possibilities of acoustical correction.

All enclosed rooms have some absorption regardless of wall or ceiling material used. Ordinary plaster absorption is about .03, but when considering ceiling and four walls, this item becomes of some importance. Let us calculate the wall area of the subject room.

$$\begin{aligned} \text{Area of Walls } (900) \times (20) &= 6,000 \text{ sq. ft.} \\ \text{Area of ceiling } (100) \times (50) &= \frac{5,000 \text{ sq. ft.}}{11,000 \text{ sq. ft. total}} \end{aligned}$$

$$\text{Absorption} = (11,000) \times (.03) = 330 \text{ units}$$

Floor absorption is very small and can be omitted because of seat absorption, carpets, etc.

The clothing of an average dressed person averages 4.2 units. Theatres are usually corrected for  $\frac{1}{3}$  audience, however, seat

<sup>1</sup> These figures are based on a frequency of 512 cycles. As the frequency increases or decreases, the coefficients vary in accordance.

absorption must be deducted in calculating audience absorption.

An ideal condition is that of a theatre having over-stuffed seats with the same absorption as a person seated. Then a preview in an empty house can be cued for exact volume setting and quality as for a full audience condition.

Theatre seats vary in absorption from 0.2 to 3.5 units in the over-stuffed type. Wood seats with wood backs average about 0.2 unit. Let us assume 500 Plywood seats for our sample calculation, then:

$$\begin{array}{r} 500 \text{ Plywood seats } (500) \times (0.2) \\ \frac{1}{3} \text{ Audience with seats } (166) \times (4.2-.2) = \end{array} \begin{array}{r} 100 \text{ units} \\ \underline{664 \text{ units}} \\ 764 \text{ units} \end{array}$$

Folded cloth or velour drapes vary vastly in absorption, however, the area used is generally so small that little error is introduced. Folded heavy velour drapes vary from 10 to 50% absorption, depending upon the fold constant, that is one hundred linear feet of material folded in drapes to 25 feet would be a 4:1 ratio, etc. Ordinary cloth fire escape door drapes vary from 3 to 10%. Assume sample calculation:

$$\begin{array}{r} 2 \text{ drapes } (5' \text{ wide}) (25' \text{ high}) (50\% \text{ absorption}) \\ 4 \text{ exit curtains } (4' \text{ wide}) (5' \text{ high}) (10\% \text{ absorption}) \end{array} \begin{array}{r} 125 \text{ units} \\ \underline{8 \text{ units}} \\ 133 \text{ units} \end{array}$$

Carpets average from about 10 to 25% absorption, the area used in aisle runners is usually quite low. Assume sample calculation as follows:

$$2 \text{ aisle runners } (75) \times (2 \text{ ft.}) (10\%) = 30 \text{ units}$$

Calculating the absorption of a proscenium<sup>1</sup> opening introduces a number of variables because of curtain area and screen absorption. Absorption varies between 25 and 40% considering screen and velour drapes.

$$\begin{array}{l} \text{Assume area } 40 \times 25 \text{ ft.} = 1000 \text{ sq. ft.} \\ \text{Absorption } (40\%) \times (1000) = 400 \text{ units.} \end{array}$$

*SUMMARY OF NATURAL ABSORPTION IN SAMPLE CALCULATION:*

Plastered Walls	330 units
Seats	100 units
Audience $\frac{1}{3}$	664 units
Curtain Drapes	125 units
Exit Curtains	8 units
Carpet Aisle Runners	30 units
Proscenium Opening	400 units
	<hr/>
	1657 units

<sup>1</sup> A proscenium is that part of the stage in a theatre or similar building between the curtain and drop-scene and the orchestra, sometimes including the curtain and its arch.

Let us calculate the reverberation time under these conditions:

$$T = \frac{(.05) \times (100,000)}{1657} = 3 \text{ seconds}$$

Referring to the chart on Page 42, we note optimum time for 100,000 cu. ft. volume requires 1.52 seconds for good bearing. Let us investigate how much additional absorption would be required to obtain this period.

$$a = \frac{(.05) \times (100,000)}{1.52} = 3290 \text{ units}$$

3290 units required total  
1657 Natural units present  
 1633 units required in form of treatment

To begin the treatment process, first calculate the possible panel area in the theatre being considered. Fig. 43 shows the side:

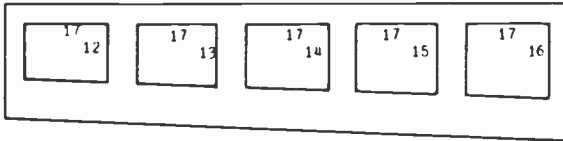

Fig. 43 illustrating the application of acoustic material to the side walls in a theatre.

wall panels which might be installed. The total area covered:

$$\begin{aligned} (12) \times (17) &= 204 \text{ sq. ft.} \\ (13) \times (17) &= 221 \\ (14) \times (17) &= 238 \\ (15) \times (17) &= 255 \\ (16) \times (17) &= 272 \\ \hline &1190 \text{ sq. ft.} \end{aligned}$$

2 side walls = (2) × (1190) = 2380 sq. ft. total of side walls.

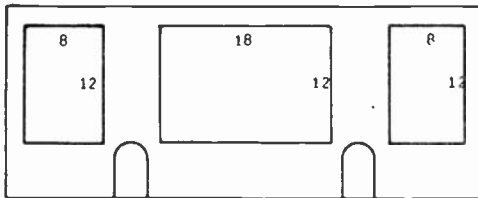

Fig. 44 Applying acoustic material to the back wall area.

Next consider the back wall area as shown in Fig. 44.

$$\begin{aligned} (18) \times (12) &= 216 \text{ sq. ft.} \\ (2) \times (8) \times (12) &= 192 \text{ sq. ft.} \\ \text{Back wall area} &= 408 \\ \text{Side wall area} &= 2380 \\ \text{Total area available} &= 2788 \end{aligned}$$



Corrections units needed = 1693  
 Wall area available = 2788 sq. ft.  
 Required percentage material absorption =  $\frac{1693}{2788} = 59\%$

The material chosen must have a minimum of 59% absorption.

ABSORPTION AT 512 CYCLES

C1	Celotex	48%
C2	Celotex	69%
C3	Celotex	76%
C4	Celotex	98%
US Gyp	Queetile	73%
US Gyp	Perfatile	96%
J.M.	Sanacoustic tile	95%
J.M.	Transite Tile	71%
J.M.	Sound Blanket	67%

The choice of the above materials will be governed by cost, possibilities of mounting and decoration requirements. Perhaps choice of higher value materials in certain areas might be an advantage.

The cost of an acoustical wall treatment job should be balanced against the cost of installing highly upholstered seats. Frequently plywood seats can be padded to increase absorption besides comfort to the patrons.

Minimum reverberation period under full audience condition should be calculated with the contemplated treatment. If too much variance between  $\frac{1}{2}$  and full audience, it might be well to consider treatment to  $\frac{1}{2}$  or  $\frac{2}{3}$  audience condition.

12. **PLACEMENT OF ABSORPTION MATERIAL.** Absorption should be considered in the following manner:

- I Seats and audience.
- II Back Wall reflections, Domes and Concave surfaces.
- III Side Wall Reflections.
- IV Ceiling.

General rules regarding material placement are very difficult to outline because every hall or auditorium requires different considerations.

**SEATS AND AUDIENCE:** Assume that a given area outdoors were arranged with balcony and seating arrangement similar to the hall or theatre conditions. Suppose this seating area were to be completely covered with sound from directional type loudspeakers. Voice reproduction might sound natural, however music, lacking reflections, would sound very thin and tinny.

Next suppose that this same area were enclosed with plastered walls and ceiling. The introduction of wall reflections would raise sound level, also change the quality, depending upon the reverberation time resulting from the enclosure. Music quality would appear to be improved, however voice reproduction might be impaired if the reverberation period were too high.

Arrangement of speakers for best results of both conditions

would require several important considerations:

1. Outdoor Conditions:

- (1) Great number of speakers required for coverage.
- (2) Illusion item very important requiring speakers placed behind screen in line with average height position of artist.
- (3) Amplifier power must be adequate to handle outdoor high level operation of speakers.

2. Indoor Comparative Conditions:

- (1) Reduce angle and number of speakers to prevent wall reflections regardless of sacrifice of direct coverage in front side areas.
- (2) Mount speakers to top of screen and point downward to audience. Illusion apparently will be improved by preventing wall reflections.
- (3) Amplifier power should be less than outdoor requirement because of additive reflections from enclosure. Response should be adjusted to correct bad acoustical conditions of building.

*REAR WALL:* Rear wall reflections are always to be avoided because echo traveling the entire length of the theatre could be seriously out of phase and time lag with impressed sound. Rear wall areas should always be treated. A path difference of 66 feet will cause one twentieth second time lag which is the critical point where echo manifests itself to the average auditorium.

*DOMES:* Domes should always be treated to prevent focus reflections. Reflections from a dome are always undesirable both from a time lag standpoint and focus spot intensity. High value absorbing material should be used in dome correction. The sound units installed in a dome can be regarded in the reverberation correction sum total however the general purpose behind correction is that of suppressing focus reflections.

*SIDE WALL AREA:* Side wall correction offers the greatest area coverage possibilities. In the majority of cases, back wall and dome corrections total only a few per cent of the total units needed for correction, the remainder must be placed in available areas on side walls.

In the balcony type hall or theatre, placement of the material on the side wall panels nearest the front serves as an advantage in lowering excessive reverberation period in that area. Balcony type theatres can usually be divided into several sections and treatment regarded for each.

Under this consideration, the open front area would generally have the greatest reverberation time with the upper balcony second highest and the main floor area under the balcony the lowest reverberation.

From a reverberation standpoint, any of the above areas could

be calculated and treated separately; however, certain sections, not in the high reverberation area, may have to be padded to prevent detrimental echo reflections. There is always a question as to material placement being an advantage in one sense and a disadvantage in another if reflections are desired to balance sound level in certain areas.

Upper side panels from front of balcony to rear of house would follow next in importance. These upper balcony areas are usually bothered with high reverberation; hence, these areas should be given second consideration.

Correction of the main floor panels under the balcony would be made only as a last resort for necessary area requirements. Care must be taken not to reduce the natural period of the main floor section too greatly, as audience absorption and low cubical contents already favor this area.

*PROSCENIUM ARCH:* If the proscenium arch is made of open lattice work and not used for ventilation or public address horns, acoustical material can be placed behind the lattice work to advantage. The use of 2" thick rock wool or balsom wool is highly recommended. Ozite or hair felt may be used.

*CEILING CORRECTION:* Ceiling correction is rarely recommended, because of cost of installation. Material so placed is not in the path of direct sound, hence very little good is accomplished. Ceiling reflections are seldom troublesome.

*FLUTTER ECHO:* Flutter echo may or may not be a serious disadvantage. Frequently a bad flutter echo condition manifested by clapping hands in the center area of the hall or theatre may appear to be very detrimental; however, little or no effect is noticed when the sound source is placed on the stage at horn location. Clapping hands generates a sharp spread wave that is quite different from that of normal sound obtained from a directional speaker. Questionable effects of flutter echo should be checked through a normal show before any decision is made.

*ILLUSION:* Proper screen or sound source illusion is very difficult to obtain in acoustically poor houses. Reflections from back and side walls frequently amplify sound greater than the direct beam sound of the horn.

Illusion in an acoustically good house is like the out of doors and speaker placement can be made to best illusion advantages. In acoustically bad houses, preventing wall reflections by placing the speakers near the top of the stage and pointing downward to the audience, greatly improves illusion. Use of least possible number of horns and choice of type of speakers having proper angle of spread materially improves sound in reverberant houses.

*DEAD SPOTS:* A weak area is frequently called a "dead spot" and oftimes it is thought that it is caused by some defect in the horn placement. Analysis of the majority of "dead spots" complaints reveals that the low level areas have the only good sound in the hall. The main areas made high in level by reflected sound are lacking in quality.

Correction of the complaint is very difficult and requires a great deal of tact on the part of the engineer handling the job. Frequently, the sale of a pair of narrow angle directional speakers will help keep sound off the walls and thus reduce reflection in the live areas. Sometimes dead spot conditions can be satisfactorily corrected by reducing the number and angle of horns used. This prevents side wall reflections, which in turn lower the level of sound in the live areas. Increasing gain control slightly brings up level in the dead area with the same sound increase in the live area.

**CHECKING SOUND:** A sound engineer should train himself to be able to discriminate between good and bad sound, also to be able to hear distortion and to know if it is coming from recording, amplifier, loud speakers or acoustical conditions of the theatre.

In checking for 7,000 cycle "highs", you wouldn't listen to a violin, but would try to judge response by the "sh" and "th" parts of speech. In checking "lows", you would not judge by boom in one certain actor's voice, but by average voices.

**13. SURVEYING AN INDOOR INSTALLATION.** When contemplating the installation of an indoor sound system, a complete survey of the location is advisable. To cover an indoor area, much less acoustic power is necessary because of the energy reinforcement produced by

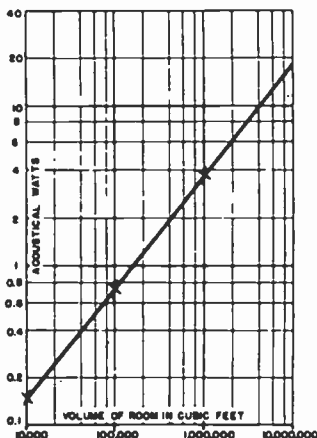

Fig. 45- Chart showing the amount of acoustic power required by rooms of various sizes. Values are approximate only.

reflected or reverberated sound waves. The graph shown in Fig. 45. gives the approximate amount of acoustical power required by rooms of various sizes. These values should be accepted as only approximate and dependent to a large extent upon the existing noise level. For a quiet theatre, the values are fairly accurate; but for a dance hall, night club, etc., ample reserve power should be available.

A side elevation of a typical auditorium or theatre is shown in Fig. 46. If possible, the exact room dimensions should be secured from the architect's plans. If the plans are not available, the house should be measured and a sketch drawn to scale. At one time, the standard method was to group all the loud speakers in a central spot just forward of the stage in the center of the building. This

is still considered good practice in churches or other places where a speaker's stand and only one microphone are used. If microphones are to be placed along the footlights, it makes a better job to distribute the loud speakers across the top of the proscenium arch.

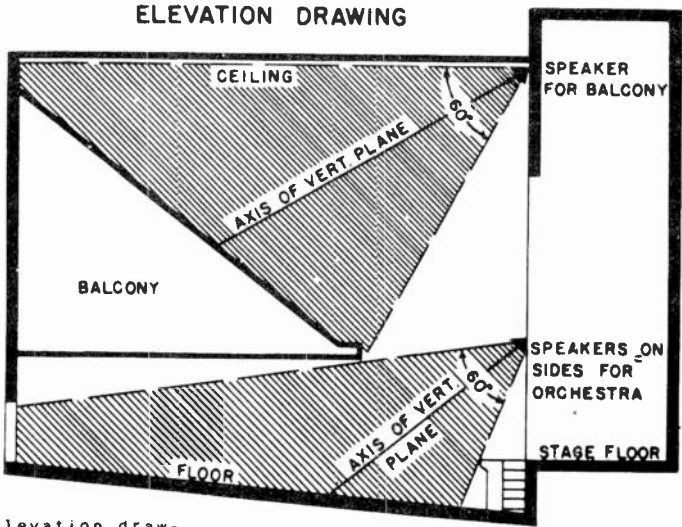

FIG. 46 Elevation drawing showing the speaker location for a typical theatre installation.

Having accurately drawn the house plans and knowing the distribution characteristics of the speakers, the speakers can then be placed in the most advantageous positions to give the best coverage. Remember that not more than  $60^\circ$  spread should be expected from each speaker unless the manufacturer specifies differently. To cover the balcony, the speaker (or speakers) may be placed along the top of the proscenium arch. For the main floor, speakers on either side of the proscenium are most satisfactory. An elevation drawing will be found of great assistance in determining the right height of these side speakers. As shown in Fig. 46, they should be pointed so that the upper envelope of the distribution angle parallels or coincides as closely as possible with the ceiling under the balcony.

If there is too much sound on the front wall of the balcony, it is advisable to place heavy absorption material, such as velour, in deep folds across the front of the balcony. When installing the balcony speakers, use the same theory; that is, place them so that the upper envelope of the beam parallels the ceiling line as nearly as possible. As shown in Fig. 46, the axis of the speaker in the vertical plane should be aimed near the middle of the balcony seats.

An ideal indoor sound installation is one wherein each person in the audience hears perfectly without having the slightest idea that electrical sound apparatus is being used. For this condition to exist, the sound system must be right in quality and the distribution perfect with regards to speaker placement. Although some-

times difficult to attain, it is really surprising what a little care and "horse sense" will do to the overall distribution if the speakers are placed properly. Those persons in the rear of the audience really do not expect to hear with as much volume as those in the front; and those in the front should not be forced to tolerate excessive volume. The speakers should be directed about three-quarters of the way back if possible.

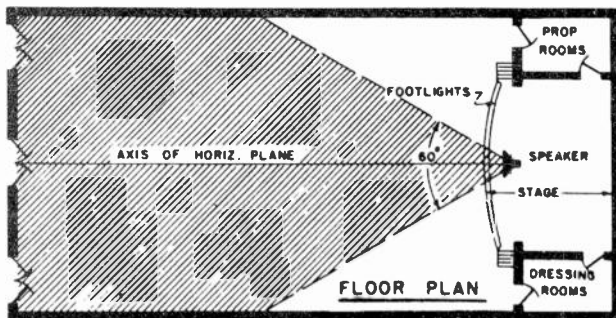

Fig. 47. Floor plan showing speaker location in typical theatre installation.

When the sound waves strike the side and back walls, treatment and reverberation problems immediately arise. A floor plan of the hall, such as shown in Fig. 47, is very helpful in adjusting the horizontal directivity of the speakers so as to minimize side and rear wall reflections. This shows a single central speaker, as would be used behind a theatre screen. If a microphone is used on the stage, the two speakers should be mounted on either side of the proscenium and directed so that the outer envelope of the sound beam travels parallel to the side wall. The beams will then cross near the center of the main floor; depending largely on the horizontal deflection angle of each speaker.

11. **ACOUSTIC FEEDBACK.** Acoustic feedback is the return of the amplified sound from the speaker into the microphone with sufficient magnitude to override the level of the original sound and develop a continuous "howl", "sing" or "whistle" from the entire system. The "pitch" or frequency of the audio oscillation (howl) is in accordance with the resonant frequency of the hall wherein the speaker and microphone are located, or the resonant frequency of the amplifier circuit, or a combination of both. After once being established, the oscillations are suppressed only by reducing the volume level from the speaker. Frequently, it is impossible to secure the desired volume from the speaker without causing acoustic feedback, in which case it then becomes necessary for the sound engineer to correct the undesirable condition.

There are a number of remedies which may be used alone or in combination: First, directional baffles may be used to point the sound away from the microphone or from surfaces that may reflect it to the microphone. Second, a directional microphone may be used to

limit the angle of response. Third, the microphone, amplifier and speakers (speakers especially) should have a flat overall frequency characteristic so as to avoid accentuated response at certain frequencies. Resonant response peaks from the speakers invariably produce feedback, even when the normal volume level is quite low. Fourth, use the microphone "close-up" to limit the sensitivity of the system. This requires the use of a microphone which operated on the "pressure" principle, such as the crystal, dynamic, etc. "Velocity" type microphones are satisfactory for wide-angle pick-up, but are unsuited for close talking. Fifth, acoustical treatment of the room is often helpful because it prevents excessive reflection and reduces the reverberation time. Sixth, a continuously variable tone control (or tone-corrector) sometimes assists in obtaining more volume without feedback. It may be used to reduce the amplifier's response at the higher audio frequencies where feedback is generally most bothersome.

Feedback is to be expected under certain conditions, and its remedy requires considerable experimenting with the placement of the speaker in relation to the microphone. Generally it is a "cut-and-try" process of elimination. In exaggerated cases, volume must be sacrificed to entirely prevent it. There are no fixed rules to follow that will be applicable in all cases; in general, keep the speakers or horns as far away from the microphone as possible and if they are directional, keep them pointed away from the microphone or any flat surface that will reflect the beam toward it.

# Notes

*(These extra pages are provided for your use in taking special notes)*



# Notes

*(These extra pages are provided for your use in taking special notes)*

# Notes

*(These extra pages are provided for your use in taking special notes)*

The text of this lesson was compiled and edited by the following members of the staff:

G. L. Taylor  
President and Chief Engineer  
Midland Radio & Television Schools, Inc.

C. L. Foster  
Supt. of Instruction  
Midland Radio & Television Schools, Inc.

C. V. Curtis  
Chief Instructor  
Midland Radio & Television Schools, Inc.

R. E. Curtis  
Technical Drafting  
Midland Radio & Television Schools, Inc.

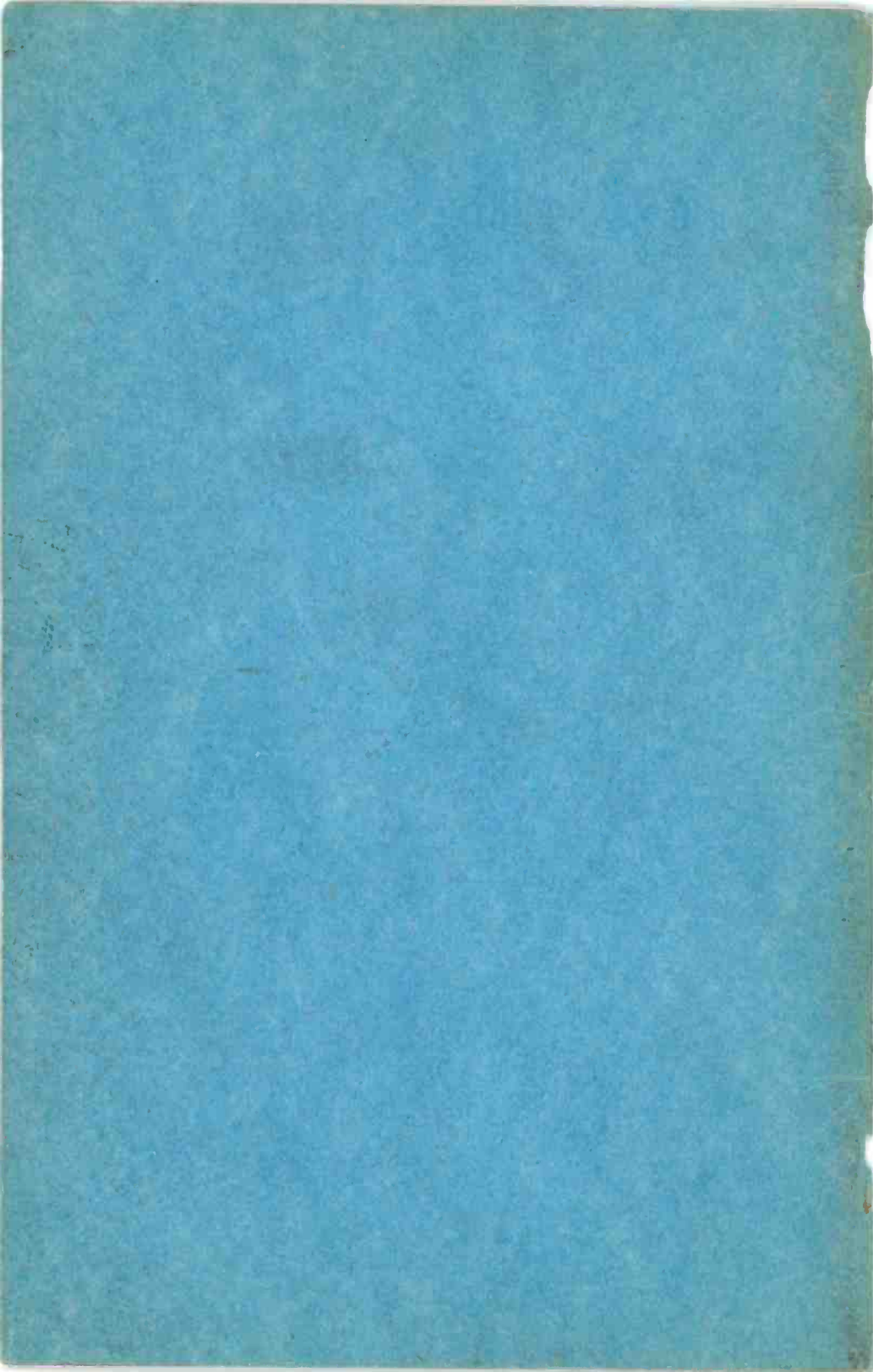



**MIDLAND RADIO  
AND TELEVISION  
SCHOOLS  
INC.**

**POWER & LIGHT BUILDING, KANSAS CITY, MISSOURI**

**UNIT  
NO.  
2**

**THE BUSINESS SIDE  
OF SERVICING**

**LESSON  
NO.  
10**

# BACKGROUND

.....MIDLAND'S AND YOURS

Midland's Engineering Staff has a combined experience in Radio and Television of nearly one hundred years. For the most part, the members of the staff may be classified outright as specialists in their respective fields..... divisions of the science.

These are the men who are behind the information contained in your lessons. Their tremendously involved experiences have been separated and condensed according to the best methods of instruction and passed on to you. Through your every Midland lesson you are being shown time-saving short cuts and labor-saving information, by men whose practical lives have been spent in the study and practice of these vitally important facts.

These able engineers, members of Midland's technical staff, are figuratively following you about, looking over your shoulder, pointing out to you the things you must know in order to become a "top-flight" radio man. They check your moves, show you where you may be wrong, and when and how you may better your methods. They explain how you may save time here and how to step over "dead logs" there. You are learning, through their broad background of experience, research and practice, how to do more in a given time.

They are teaching YOU how to increase your earnings!

By studying your lessons thoroughly.....by following their instructions.....you are gaining, in a small fraction of time, that which took years and years for those men to learn.

You are training yourself for a career in Radio and Television. With all this information and knowledge at your command, you will be able to laugh at the weak, worn-out excuses of the self-pitying failure. You can turn your back on "pull" and snap your fingers at "luck".

You will be able to make your own way to your own goal. You'll be "on your own", equipped to make a fine living and achieve a respected social position for yourself and those who are nearest to you!

Midland Engineers are standing behind you----and your Future!

Copyright 1941

By

Midland Radio & Television  
Schools, Inc.

PRINTED IN U.S.A.



KANSAS CITY, MO.



# Lesson Ten

## THE BUSINESS SIDE of SERVICING

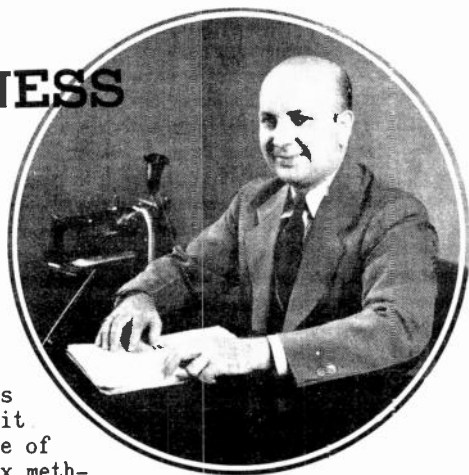

"The qualifications of the successful Service Engineer do not end with technical knowledge. Many a competent serviceman has failed to realize the profit he deserved, simply because of the careless and unorthodox methods he has used in handling the financial end of his establishment.

"Whether or not you intend to enter the field of radio servicing, you will find that this lesson contains many suggestions relative to good business procedure."

1. THE SERVICE ENGINEER IS A PROFESSIONAL MAN. In several instances we have mentioned that servicing is a business. The importance of this fact cannot be stressed too greatly. In this lesson we will approach the problems of the service engineer from a new angle; that is, from the business angle. In addition to such subjects as advertising, bookkeeping and customer relations, we will give suggestions for making extra dollars in odd moments.

With adequate technical knowledge, with good equipment, and with the knowledge of how and where to sell his services, the service engineer can keep busy; but at the same time he will actually have to scrape and scrimp to find the necessary money to pay the landlord every month. However, if he operates his business with proven business methods, he not only will welcome the landlord at the door but will be well known at the deposit counter of the local bank. Service engineers must learn how much it costs to make a call or do a job, how much they should spend for advertising, how to collect for their work, and whether they can afford to do a job for less than cost as an advertising method of obtaining additional work that will return a profit at a later date.

The radio service engineer is not a handyman in any sense of the word. Any man who has this attitude toward his work, has lost his job before he starts. On the contrary, his is a profession of which he can be justly proud. And let us emphasize this question of a profession. The service engineer can well be compared to any other professional man. He is a specialist in his field trained to give his services to his customers for satisfactory fees. The

public in general goes to a doctor who can be trusted, one who has a reputation in his field; paying high fees in many cases, but doing so gladly because they know they can depend upon his services. Equally, the conscientious service engineer can in a remarkably short time, build himself a reputation for honesty, fairness, and dependability.

Now, if the service engineer is a professional man, does it not follow that in all his personal contacts with his customers he should conduct himself accordingly? In an earlier lesson, we touched lightly upon the subject of personal appearance. We cannot overemphasize the importance of this single factor. Cleanliness, not only in appearance but in habits and speech is essential. When making calls to a customer's home, make certain that your suit is freshly pressed, that your shirt is fresh and that a necktie is worn. Your shoes should be shined and in stormy weather, precautions should be taken that mud or snow is not tracked into the customer's home. Of course, a fresh shave and a recent hair cut are absolute necessities.

From this subject, it is but a step to the condition of your service shop and equipment. Again, let us look into the office of the professional man. You have visited many offices of dentists and undoubtedly have noticed variations in the appearance of these places. You also have probably visited such places and become disgusted with the general untidiness and disorder, and have resolved that you would never return to the place. We do not mean that the equipment you use requires sterilization after each and every job, of course, but the neat service shop wins the confidence of the customer. On the other hand, a disorderly looking service bench leaves a doubt in the mind of the customer as to the sincerity and ability of the service engineer. A sloppy looking service bench indicates a poor worker, and very few people are looking for second or third rate repair jobs which they would expect from the sloppy service engineer.

Also, all portable equipment and tools should be kept clean and neat. If a case is used for tools, each tool should have a special place and should always be kept in that place. Under no circumstances should the service engineer wrap a number of screwdrivers, pliers, soldering irons, etc., in a dirty rag and carry them into a customer's home.

While working on a receiver in a customer's home, always protect the customer's furnishings from dirt or damage. Usually, newspapers spread over floors and rugs are sufficient protection. Of course, these must be gathered up on completion of the job and deposited in the customer's waste basket, with his permission.

Servicing requires salesmanship of the service engineer. Salesmanship covers many angles besides personal appearance and neatness. Let us look at the personal contact side of this question. Personality is a quality which may be a deciding factor in the success or failure of a business venture. You have heard department store slogans such as "The customer is always right". Naturally such a slogan cannot be applied literally in service engineering, yet the basic principle can be followed. Customers



should always be treated with courtesy and respect regardless if they are interested in a job costing \$1.00 or \$15.00. A serviceman must never be too busy to treat a customer with respect and courtesy. Even though you may lose five minutes to half an hour in a discussion with a customer, if he leaves with the impression that you have his interest at heart, he will come back again and tell his friends as well. This courtesy applies to telephone conversations as well as those conducted in your shop. Remember also, the customer knows nothing of the technical side of a radio and may ask questions that to you, may seem silly. Take time to explain things in a non-technical language which your customer can understand. Such terms as "selectivity" and "sensitivity" should not be used. Instead, use such terms as "ability to separate stations" and "ability to receive distant stations". In place of talking about "fidelity", you should use such an expression as "reproduction of low notes and high notes with equal strength". Always explain to the customer whatever you find wrong with the receiver. Never try to hide behind words if you cannot answer a customer's questions. Frankness will always repay you with more business at a later date.

2. THE SERVICE ENGINEER IS A BUSINESSMAN. We have mentioned that the service engineer is a professional man comparable to the doctor or dentist; however, let us now consider another fact. A service engineer in order to succeed in his chosen field must also be a businessman. Not only must he be a businessman but he must understand all the various branches of his business. This suggestion to become business-minded and to run your service shop like a business is made in order to relieve a regrettable condition in the service field. Those who run their shops with no thought of the business angles find that in order to earn a bare living, they must work twelve, fourteen, and sixteen hours a day with no leisure time for study or play. If business methods are understood and applied to your shop, it will not be necessary to work more than a reasonable number of hours a day and these hours will produce a reasonable amount of revenue.

Running a service station like a business does not mean that if a resistor is being replaced, no further time should be spent in checking the receiver. Proper business administration can develop a certain program of operation which will be profitable and at the same time, will represent a thorough check upon that receiver. Such a program would call for the employment of the most modern forms of testing equipment, made possible by profits accrued from proper administration. The ownership of such modern equipment would enable sufficient saving of time in certain operations, so that all the operations required for thorough testing would be possible without involving more time than required for a casual routine test with inferior equipment.

Running a service station like a business means that if a specific unit has been replaced and the supplementary check shows correct operation of the receiver and amplifier, the operator will not waste additional time in *elaborate* and *unnecessary* tests,

unless he is being paid for such a thorough test. Certain *routine* tests are a part of general service operations and defects discovered and properly remedied, but it is not common sense to bend backward to please, particularly when such action changes what would be a profitable call into an unprofitable call.

The use of inferior replacement parts, because it means greater immediate profit, is an inviting but dangerous procedure. The man of sound business mind is trying to establish himself solidly, and he realizes the fallacy of such action. He is aware of the financial loss entailed in making a free repeat call, a loss which includes loss of time, traveling expenses and other incidental expenses. It is not strange then that the sensible businessman avoids free repeat calls. His work is guaranteed, and the guarantee must be lived up to fully. This guarantee covers the replacement parts as well as the actual repair; hence, it does not pay to use inferior parts. It means a loss rather than a profit.

The first requirement of a man who is to guide successfully a commercial establishment, is to realize the responsibility of the financial end of the business. Whatever funds come into the concern belong to the concern. This is far more important in a small company with limited finances than in a large company where plenty of money is available. The fact that the operator owns the concern is of no consequence. The time will come at the end of the year to withdraw whatever profits are available or the proper portion thereof. During the year, all of the funds in the business belong to the business, and the operator should pay himself a fixed weekly salary the same as he would do with any of his employees. The amount of this salary should be fair but not exorbitant, and its value can be determined only by business conditions.

Some men are born with the commercial instinct; others must cultivate it. Cultivation is possible, as is evidenced by the numerous schools which teach various branches of commercial activity. Experience is, of course, a marvelous teacher. The majority of radio men who operate service organizations have migrated into the field from many other forms of activity; very few with business experience. Where this is true, the commercial instinct must be cultivated.

Eyes and ears must be open to recognize ways of reducing expenses, increasing sales, operating more efficiently. The mind must be working to create new ideas which will prove advantageous to the operations of the company. Common sense must be practiced when arriving at decisions.

The sensible businessman does not rush pell mell into a plan he dreamed of the night before, or one which appears marvelous at first thought. Weeks and months need not elapse in deliberation, but deliberation is required in business. Analyze every plan, seek out its weak points, and strengthen them; establish the strong points and make them stronger.

The business-minded man realizes the importance of accurate statistics as they pertain to the activities of his business. He

does not feel that the keeping of such records is wasted effort. He realizes that records are of definite aid in the formation of decisions concerning the future operations of the business, as based upon past activities. He realizes that records tell him the condition of his business; that only by keeping proper records can he discover and plug the financial leaks, gauge the value of various phases, establish the merits of an idea which is being tried out.

3. PROFITS AND LOSSES. *Why is service income low? How can it be increased?* Let us analyze the income of a service station. There are two general sources of income. One is that secured from the sale of service time and knowledge. This is the money received for the time spent and the knowledge applied in rendering service. The other source of income is that secured from the sale of parts and accessories sold individually or in connection with a service job.

Let us now segregate these two forms of income and consider the sale of service time first. The money received represents the service charge. An analysis of service charges made by servicemen located in different parts of the United States shows that the price ranges from \$1.00 per hour to approximately \$3.50 per hour, with the greatest number being within the range below \$2.00 per hour. More than likely, you too, are within this range. Are you one of the few men in the United States who knows that the price he charges per hour is sufficient to cover the cost of the hour sold? If you are one of these men, consider yourself a rarity, because there are comparatively few radio service station operators who realize that knowing costs is one of the most important functions of the man who controls the destiny of a business.

Now let us ask a question. How do you know that \$1.00 per hour is enough; or that \$2.00 per hour is enough; or that \$3.50 per hour is enough to return a profit? How do you know that you can afford to do free inspections, even if six out of every ten result in complete service calls? It is perfectly conceivable, and for that matter, a reality in altogether too many cases, that having made the free inspection call, and having succeeded in convincing the customer that the receiver should be serviced, your charge for your time is not sufficient to cover your basic costs.

Speaking about losses on the sale of service time, it is natural that a loss may be entailed upon several jobs. Of course, every effort will be made to avoid such a loss, but there are times when a profit is impossible. The important thing in connection with the proper administration of a business is to know the extent of the loss and just how many such losses the business can afford. This means knowing the cost of the time sold. If you are selling time without knowing what the costs are, how can you establish a resale price which will be profitable? Attempting to sell something without knowing what it costs is equivalent to servicing a receiver blind-folded, with the additional hazard of endangering the very existence of yourself as a service station operator.

Let us now consider the sale of parts. How can you decide which is the most profitable manner in which to charge for the re-

placement parts you use in a radio receiver? Should you sell at cost, cost plus, list price, or at a definite sacrifice? Do you know whether the profit you earn on the sale of the labor in connection with any service job is sufficiently great to absorb a loss on the sale of a replacement part, if such a loss does occur? You do not always make a profit on the sale of your parts. That, you might just as well realize right now. Certain parts, when sold to the customer at list price will entail a loss on your part, even with the 40% discount you receive from your supplier. This is so because your business entertains certain definite sales expenses which relate to parts. It is your duty, as the man in control of your business, to know just what these sales expenses are, so that you may definitely establish the best method of selling these parts. You may feel that the most attractive offer you can make to the customer is a flat rate charge for time and parts. You may be right as far as the customer is concerned, but how about your pocketbook? We are not disputing the attractiveness of a flat rate charge. What we are concerned with is whether or not that flat rate charge, covering time and parts, is the proper one, so that you will earn a profit on the complete job. You may say that you are earning a profit. Can you prove it definitely by establishing your costs for the time sold and for the replacement parts which are used on the job?

Radio service stations, like other commercial enterprises, offer "leaders" to attract business. The sale of such "leaders" is carried on at a definite loss and it is hoped that the other business resulting will be profitable to the extent where it will offset the loss entailed by the sale of the "leader".

Once again, we are confronted by the same problem. Without full knowledge of cost and overhead expense figures, it is impossible to establish the loss entailed by the sale of this "leader" and the amount of profit which must be earned on the sale of the other items in order to offset the "leader" loss. The solution is not the elimination of "leader" sales. Such sales represent sensible business. The solution is the establishment and proper application of cost and expense figures.

We would like to take this opportunity of bringing to your attention one very important item in connection with losses and profits. It is a very simple matter to take a loss upon any one transaction. Perhaps the sum involved is not very great, or perhaps it is quite substantial, considering the total investment in the business. At any rate, it is imperative to understand that in order to make up that loss, an entirely separate and distinct transaction must occur. Furthermore, somewhere along the line, a greater than the usual profit should be made, if possible, in order to offset the aforementioned loss and still not diminish the normal profit upon subsequent transactions. This is equivalent to saying that if a loss occurs on one transaction, the profit made upon the subsequent transaction may not compensate for the loss on the previous transaction. As stated on several occasions, the ideal arrangement is to make a profit upon each transaction consummated, but where a profit is not possible, the loss must be

minimized. If a business is conducted on the premise that the profit on one job is going to offset the loss on another, the net result is no profit on the two transactions. If this happens, a business is carried on with the expenditure of a great deal of effort and the risking of funds without any financial improvement or progress at the end of a period of activity.

Let us now speak about the normal amount of profit on the sale of parts. Since the maximum amount of profit upon parts is definitely limited by the fact that a list price is established, and you have certain costs and expenses, your ability to earn a profit depends upon what you charge. If you can charge the list price, you are making whatever profit is possible and permitted by existing circumstances and conditions.

As to the sale of time, it is now generally believed that you are justified in establishing a mark-up of at least 25% over and above your cost and "shop expenses". This, of course, is not the limit. You can charge much more, if you know that you will deliver the money's worth. A high caliber service station, catering to a type of clientele with more than average income, is justified in a mark-up as great as 100%. If such a station operates at a cost of \$2.00 an hour, it is justified in charging its customers \$4.00 an hour; that is, if \$4.00 worth is delivered and the customers are able to pay. It is, of course, possible that your locality is such that your customers cannot pay this price. If such is the case you will usually find that your expenses do not run high enough to establish a cost to you of \$2.00 an hour. If you are operating in a locality where the income of your customers is such that your charge for time is limited to \$1.75 per hour, it is imperative that you should be operating at an expense which will develop a cost to you of not more than \$1.40 per hour.

In speaking about the proper management of a business, it is necessary to consider the size of the enterprise. By size we mean the size of the business, the amount of money which is handled, the program adopted for the development of sales, the manner in which the funds of the concern are spent, etc. The larger the concern, the greater is the number of items which must be considered in formulating the plan of administration. In our case, we are concerned with establishments with incomes of from \$1,000 to about \$5,000 per year. Consequently, a number of the details which would normally exist in larger organizations can be omitted and it is possible for us to discuss things on a certain level. Essential acts of proper business administration determine the sales market, sales promotion, sales quota, buying, merchandising, inventory, and expense. This applies as readily to the man who is just starting in business as to the man who has been in business for several years.

4. SALES POSSIBILITIES AND LOCATION OF SERVICE SHOP. The topic of sales possibilities is one of wide scope with a large number of ramifications. A man starts in business, or is in business because he feels that he can supply the needs of the people located within his trading area, and because he feels that such a

business will earn his livelihood. The actual territory within the aforementioned trading area is naturally dependent upon how extensively the man will operate. Whether or not sales possibilities of the proper magnitude exist, depends upon two factors; the nature of the product being sold and the number of people located in this trading area who are interested in or will buy this product.

The number of people available to whom such service can be sold depends upon the locality of the shop. Many service stations are poorly located; many others advantageously located. There are numerous factors which contribute to the value of a location. One of these, which requires extensive consideration, is the proximity of competing establishments. Another is "rent". The presence of a competing establishment does not in itself mean that a location of our choice is poor, but if an analysis shows that the number of available customers when apportioned among the existing shops is insufficient to return the proper income required for the successful operation of our man's business, then the location selected is a poor one for the newcomer. To risk an investment on the ground that an effort will be made to take business away from already existing competitors must be supported by outstanding ability, efficiency, and ample capital.

There are certain localities where the need for radio service business exists, but the number of prospective customers is so few that it prohibits the starting of a full-time business. Under such circumstances, it is essential to recognize the existence of the limiting factor and to start a service business of such proportion as will not require an expense greater than that consistent with sales possibilities.

A service organization should, of course, be located in the most advantageous spot with respect to the possibilities of securing business and attracting trade from among the people who daily pass the establishment. This reference is, of course, subject to the limitation that it pertains, primarily, to the man who has a shop. The man who is operating from his home has no choice of location. As a general rule, such houses would be classified as being in the residential section. Consequently, the amount of business secured from transients who pass the location is very little, if any. In regard to stores, it is necessary to consider also that the greater the number of people passing a certain spot, the greater is the valuation of this location; hence the more would be the rent. It is, therefore, necessary to find the best compromise between trade and rent.

It is appreciated that the better the location, the better the business; but somehow or other, a service establishment does not, as a rule, depend upon transient trade, and consequently, does not justify a high expenditure for rent in order to secure a location on the main artery of the town. Of course, it is most advantageous to be located as close as possible to a main artery, but if the difference in rent for a space on a side street near a main artery and the space on a main artery is appreciable, we believe that a service shop located on a side street will fare

equally as well in the long run. Naturally, if the service station is also selling receivers which are on display and if the sale of receivers represents an appreciable portion of the total income, then it is necessary to secure the best location, even if the rent is considerably higher. But even in this case it is necessary to weigh in the balance the ability to carry on profitable operations with a high rental.

Referring once more to the man who is operating from his home, he too has a rental problem in that in establishing his expenses, he must include a certain amount as being the rental of the room or the basement which he is occupying. Altogether too many men who operate from their homes, ignore the fact that the space they occupy is worth a certain amount of money. Perhaps the rent for the room occupied is a small portion of the total rental of the building, but no matter what it is, it should still be included in the expenses.

5. COLLECTION OF ACCOUNTS. One of the problems of service stations has been the collection of small accounts. When we say that such an item is a problem, we do not necessarily mean that a large amount of money is involved. The problem is the collection of such items as \$2.00, \$3.00, or \$4.00. It does not pay to engage an attorney because the expense is too great, and collection agencies charge too much when collecting such small amounts. In New York City there is located what is known as a small claims court, where the creditor, without recourse to a lawyer, can present his case before a judge. He proves the authenticity of the claim and the judge, or person presiding in the court, renders a decision which is final. In some towns, the municipality employs what is known as a public defender for the purpose of handling small claims. Which of these plans is in operation in your town, we do not know, but if you are going to run your business properly, it is to your interest to find out what practical method exists for the collection of such sums.

6. KEEPING OF RECORDS. It was mentioned in the early part of this lesson that a man who is business-minded recognizes the value of records and utilizes these records to the fullest advantage. It is now time to discuss the records you should keep in order that you may know how well your business is functioning.

Properly kept records are an advantage because they provide the answer to such questions as: How much money have I taken in and how much have I paid out? When did I take in that money and what did I spend it for? Am I paying more rent than the business warrants? Can I afford to buy that new oscilloscope now, in two months, or ever? Can I afford to spend as much as I do on sales promotion, free service calls, advertising? Can my business stand the cost of the service car or shall I get the trucker to haul my sets to and from the shop?

How much business did I do last year compared to this year; January of last year compared to January of this year; any month of last year compared to any month of this year; what seems to be my slack period; which is my busiest?

I need more money personally; can I pay myself more; if so, how much more, or should I take less? Can I afford a helper to do the simple work? In case of necessity, what is the lowest service charge I can afford to make before turning down a job for a customer to whom charges are always "too high"?

What is the actual cost of one hour's service; what expenses go into the making of that cost; how do I calculate that cost and know it is correct?

Business records are a real necessity in many circumstances. Suppose your business expands and you need some ready cash quickly. If you can give your banker proper evidence as to your responsibility he will lend you money at 6% per year. But you need complete records from which to prepare a proper statement if you hope to persuade your banker to oblige you. The banker may be willing to assume the risk for a return of 6% per year or 1½% per month, because your business records, if properly kept, enable him to define the exact extent of the risk he takes.

If on the other hand, you do not have business records, you will have nothing but your personal unsupported statement of the condition of your business. While the banker would have no reason to question your veracity and might be willing to accommodate you, he cannot do so in fairness to his depositors and stockholders, nor to the satisfaction of the state or federal bank examiners.

It is possible, although not probable, that in reading this you are so thoroughly convinced of the need of records that your newly acquired enthusiasm may lead you to over-indulgence. Just as it is possible to eat too much or to drink too much or to exercise too much, so it is possible to do too much record-keeping. If that happens, record-keeping will be an unnecessary expense and a waste of time. As in all other activities we must consider the principle of balance and proportion. If one adopts a balanced diet, one will eat neither too much nor too little.

Thus, in the keeping of records it ought to be clearly understood that record-keeping is only a means to an end, and that the records should not exceed those required to show the result of business activity. It ought to be understood that the detail into which record-keeping goes should be commensurate with the size and nature of the business and that the whole scheme of record-keeping should be designed with the idea of practicability in keeping with the average administrative ability. Business should always be the main consideration and the records should be designed to fit the business, and not the business carried on to fit the bookkeeping system.

There are many systems of bookkeeping designed for the use of the serviceman. It is not our purpose here to discuss the merits of any one system but we do wish to emphasize certain very definite points which must be included in whatever system you use. It is obvious, of course, that a system designed for a business of \$5,000 a year will not be satisfactory for a business of \$50,000 a year. However, the basic principles of both systems are essentially the same and it is these principles which we want to cover in these pages.



7. THE BALANCE SHEET. Let us first look at the most important record of any business. This record, usually known as the balance sheet, shows the condition of your business at the moment it is made by giving you a complete picture on paper of your assets and liabilities or in other words it indicates the net worth of your business. This statement is not a running record of all the activities of your business, but is made up from other running records. Large firms rarely make up this statement more than once or twice a year due to the amount of work involved. However, small firms can afford to make up this statement at least once a month and we strongly recommend that this be done. It will be possible, from this statement, to tell whether your business is running "in the red" or at a profit.

The Balance Sheet represents the "status quo" of the business as of the date on which it is written. A balance sheet might be considered as a still picture; a snapshot of the business. It should always show the date on which it was made. Without the date it has no value, because as soon as one transaction takes place subsequent to the date of the "writing up" the items on the balance sheet are changed. It may not change them all, but it will change at least two of them.

A Balance Sheet taken on February 28th is good only as of that date and does not show the condition of the business as it is on March 31st if the business is a going concern.

While the balance sheet is extremely important it has its limitations as pointed out in the preceding paragraph. Yet it is the only means a proprietor has of getting a good look at his business "standing". He might deceive himself greatly by looking at a correct balance sheet three months old and concluding that he is sitting pretty. Unless the balance sheet is brought up to date whenever needed, or taken off afresh, it has no current significance.

This does not mean, however, than any balance sheet a month or more old is valueless and might as well be thrown away. By all means save them carefully once you have started making them, for the worth of your balance sheet is enhanced with age. It has value for comparative purposes.

The balance sheet is so named because of the character of its makeup. We have all seen the old-fashioned scales or balances which once were used by every grocer, butcher, and baker. The weights were put in one of the scales; the bag of sugar, the leg of lamb, or the cookies in the other side. When the scales balanced perfectly, we assumed that we received the correct weight of whatever goods we were buying.

The balance sheet is similar except that one side of the scales hold the "assets", the other side holds the "liabilities" and the "capital" of the business. The scales should balance.

Let us write a simple balance sheet to illustrate the comparison to the balance scales.

BALANCE SHEET  
Best Radio Service Co.  
J. Doe, Prop.

Date: December 31, 1940

ASSETS	LIABILITIES		
Cash	\$1500.00	Notes owed on Car	
Shop Equipment	500.00	& Shop Equipment	\$450.00
Delivery Truck	300.00	Capital	<u>1850.00</u>
Total	<u>\$2300.00</u>	Total	<u>\$2300.00</u>

You will note that the Assets and Liabilities balance each other. The assets are the items which the business owns or possesses. The liabilities are what the business owes or in other words the claims outstanding against it. The capital is what the business owes the proprietor. If J. Doe were to sell the above business he should realize \$1850.00 if he has valued his equipment correctly. The question of valuation of equipment will be mentioned later.

Before investigating the items which go to make up the "assets" side of the balance sheet, we make bold to insert a pertinent suggestion which may save you a lot of time. It is this. Unless you are willing to promise yourself that henceforth you will conscientiously distinguish between your private affairs and your business affairs, you may as well stop reading and put this lesson away; it will not be of much help to you. As we progress, the reason for this suggestion will be shown repeatedly and in a way we believe will leave no question as to its sincerity.

8. ASSETS. The item of "cash" on a balance sheet represents the amount of cash on hand at the date of the statement. Sometimes the item is labeled "cash on hand and in bank". This indicates that the major portion of the cash is in a checking account and that a small amount of cash called "petty cash" is kept on the business premises to meet small expenditures which do not warrant the writing of checks.

The proprietor must not consider the business checking account as his personal checking account and use it to pay his household or personal expenses. The business cash in the bank should never be touched for other than expenditures in connection with the business. The owner should take from that cash no more than his fixed salary or his fixed drawing account. If, in case of real necessity, the owner takes some of the funds of the business, he should show this on the records as an "advance to the proprietor" and repay it at the first opportunity. This is the only instance where a man may mix his private and business affairs.

Trade accounts receivable arise when a sale is made of time or parts, and payment in full is not received when the job is completed or the sale is made. In other words, trade receivables are created when credit is extended for the entire amount or any part of a service charge, a sale of goods, or both.

In this connection it is well to insist that the serviceman have fixed terms of payment. Cash on delivery is the ideal method. It cuts short bookkeeping, as well as collection worry and effort. It eliminates the "chiseling" of customers who want to pay but always less than the amount of the charge. The serviceman having no security once he has given up the repaired receiver is often tempted to cut something off his charge to collect the bill. That is not unusual in any line of endeavor. "Cash on delivery" goes a long way toward curing it, but it is often not practical.

When totaling your receivables, do not include any which you know you will not collect. Any receivables which you know you will collect in part should be included only so far as the collectible amount is concerned. In other words, set up only the real value of your receivables and not necessarily the whole amount. If all are good and collectible the face amount is the value. Any of these accounts on the balance sheet which are not worth the amounts as shown will be reflected as an increase in the capital, and will produce a misstatement of the true condition of the business.

"Accounts receivable proprietor and employees" are created by advances to these persons, parts purchased by them and not paid for, services rendered to them by the business or personal payments made by the business for their benefit.

It should be understood that the average radio service organization does not stock up heavily on parts. This is both logical and fortunate. It is logical because, with the multitude of receivers of different design, it is impossible to determine what items should be carried in stock. It is also fortunate because any and all inventories of stock in trade are, to a degree, subject to ultimate unsalability due to obsolescence, and that means loss. Whatever stock is carried should be properly controlled and valued. Control is necessary so that parts will not be ordered which are already in stock but have been overlooked due to lack of inventory records. A simple card file alphabetically or numerically arranged will fill the bill. A card for each part number with proper description of quantity and cost should be kept.

Just how stock on hand should be valued is important from the balance sheet standpoint. Listing the cost price is all right, provided that there have been no reductions in cost since the part was purchased or acquired, and provided that the part is not obsolete. Of course, the stock must be in good condition. Broken or "robbed" parts are not worth their original cost. If a reduction in price has taken place, the reduced price should be substituted for the cost. If, however, prices have been increased the old cost should be listed, because increasing the value of unsold parts results in a profit which will not be realized, if the part is never sold. It is better to take the profit when the part is actually used. That, incidentally, is a fundamental rule of sound business; never take a profit until it is earned, but take your loss as soon as it becomes apparent that you will have

to take it some time in the future if not immediately. The "inventory" item on the balance sheet is the total actual value of the items when correctly priced. That holds good for tubes and receivers as well.

Very often at the end of the month when the balance sheet is made up there will be some uncompleted or unbilled jobs in the work shop. Labor, overhead, and parts have gone into these jobs. The parts or tubes have been taken out of the inventory and put into the job while the labor has been taken out of the expense. Both material and labor to date have been charged to the job. Therefore these uncompleted or unbilled jobs must be set up by themselves on the balance sheet. Otherwise their value will be overlooked and their absence will appear as though the business has suffered a loss to the extent of the material, labor, and expense which has gone into them. The item "inventory of work in process" is designed to take care of this situation.

The item "shop equipment" on the balance sheet, an asset also, represents the current value of the equipment in the shop which is needed for its operation. This item includes the value of the tube tester, oscillator, oscilloscope, and other test instruments.

At what value should this equipment be shown on the balance sheet? In the case of recently purchased equipment, the value obviously is the cost of acquisition, provided that the purchase price was not unreasonably high. Equipment bought at bargain prices should be set up at the purchase price also, despite the fact that it is worth more than was actually paid. Since the balance sheet deals with the investment it is obvious that no man is justified in valuing at \$400.00, equipment he purchased for \$200.00. This is merely another instance of being honest with one's self for while the higher price may make the investment look "bigger" and therefore more "important", the other side of the story is that the higher the equipment valuation, the greater becomes the every-day operating cost of the business. This will be shown later in this lesson. Our advice, therefore, is not to increase the valuation of your equipment as shown on the balance sheet above its actual cost to you.

Practically all service organizations have a car or delivery truck which is used in the business. In most cases this automobile is used for private as well as business purposes. Unless the business use is much less than the private use, the automobile should be considered as part of the business equipment. If the automobile is used for business only, then all the expense of operating it should be borne by the business. If, however, the car is used partly for private purposes, the expense coincident with private use should be eliminated from the expense of the business and charged to the proprietor.

For practical purposes the cost of the auto should include the finance charges, if any. If, for example, the automobile cost \$250.00 and the finance charge is \$40.00, the value on the balance sheet may be considered as \$290.00. This is not the best or most correct valuation, but to break this valuation down into

cost of automobile, finance and insurance charges would lead to complications in record keeping too great for a serviceman to cope with successfully.

Nothing in this world lasts forever. All things suffer wear and tear due to use or the action of time and the elements. The equipment of the service organization is no exception to this rule. While the wear and tear may be slight, there is another factor which tends to make equipment useless and therefore valueless. This is obsolescence.

This fact should be reflected in the valuation of the equipment in a going concern. An oscillator or oscilloscope which has been in use for two years is not worth the same as a new oscillator or oscilloscope. That such is indeed true is proved by the fact that used equipment can be bought at far less than new equipment and that the usual manufacturer's guarantee does not hold with used equipment.

The combination of wear and tear and obsolescence is called "depreciation" and depreciation should be reckoned with because it is an expense of doing business. The expense connected with being in business is never fully stated unless there is included the element of depreciation of the equipment used by the business.

Consider the service equipment. Suppose that we estimate its total value as \$500.00. How fast does that equipment wear out and how long will be required for it to become obsolete? It is difficult to make a worth-while prediction in that regard. One thing is sure however. The service organization which prospers is the one whose up-to-date equipment enables it to compete insofar as the service charge is concerned. Such competition is possible only because of the labor saving in the diagnosis and the correctness of the repair work done. Such an organization may well consider five years as the limit of the useful life of its equipment. In that case the value of the equipment should be wholly depreciated in five years.

9. LIABILITIES. We have listed the items which a business owns or its "assets". Now we must list the items which a business owes to others, or its "liabilities". The difference between the assets and liabilities, if any, represents the capital of the business which the owner contributed plus or minus any profits or losses that may have been experienced since the proprietor started in business.

A "liability" is an honest claim held by an outsider against the business. For example, if parts or tubes are purchased on open account; that is, not paid for C.O.D., the wholesaler selling these parts has an honest claim against the business. The business has a liability to the wholesaler for the price of parts so purchased. When the business pays for the parts or returns them and the wholesaler accepts the money or the returned parts that liability is extinguished. An unpaid bill for gas or electricity used by the business is a liability. Wages earned by but not paid

the proprietor or his helper are a liability of the business. Transportation charges on goods shipped or delivered are a liability until paid. Let us now list the main liability items which we may reasonably expect to encounter in the operation of the average institution.

The first of these is the "Accounts Payable Current". This account should include all current debts of the organization that are unpaid at the date of the balance sheet. By current debts is meant those incurred in the everyday operation of the business. The date on which the debt was incurred is of no importance. The nature of the debt and the terms of the vendor determine whether the liability is current or otherwise. For example; parts, tubes, and supplies purchased on a "10 day 2% cash discount, 30 day net" basis if not paid for at purchase are current liabilities until paid. Whether you have been billed or not at the time of setting up the balance sheet does not matter; as long as you have received the goods and used them or put them in stock and included them in your inventory or charged your customer for them, they represent liabilities until paid for.

The next liability account is the one called "Notes and Contracts Payable". This item on the balance sheet should include all liabilities of the business for which the business has given a note, as in the case of borrowed money; or signed a contract of payment, as in the case of equipment purchased on the time payment plan. It does not seem necessary to enlarge on the nature of a note payable other than to describe it as a written and signed promise to pay on an indicated date in a specific manner a stipulated sum of money.

"Accrued liabilities" are, generally speaking, liabilities which have come into existence during the month, for which the business is not billed at the date of the balance sheet because payment is not due until a later date. They must be included in the balance sheet, since if they were neglected, the actual liabilities of the business would be understated. In a large firm some accruals are often overlooked in order to save routine book-keeping effort and because the setting up of these liabilities would not noticeably affect balance sheet comparison. The theory is that these accruals average themselves month after month. In a small business such as the average radio service organization where a small amount of expense has a visible effect on the total liabilities for balance sheet purposes, it may well be that failure to accrue expenses at the month's end will result in varied balance sheet totals for consecutive periods, which will cause the proprietor to doubt the correctness of his cost-keeping.

Suppose, for instance, the proprietor draws \$40.00 per week and the helper \$25.00. Saturday is payday and the end of the month comes on the preceding Thursday. Now the end of the month is "balance sheet time". By Thursday the proprietor and helper working a six day week have each earned two-thirds of a week's wages. That would be \$26.67 for the proprietor, and \$16.67 for

the helper, a total of \$43.34 for both. Because this money will not be paid until the following Saturday, which falls in the next month, the amount of \$43.34 is a liability of the business on Thursday when the balance sheet is made up.

To avoid the danger of becoming confused in your attempt to be fair to your business you must continually remember that your aim in preparing a balance sheet is to portray the condition of your business at the date of the balance sheet as accurately as possible. Any rent, wages, taxes, telephone expense and power and light costs, if unpaid at the time should be shown as owing. The smaller the business, the greater the need of "watching the pennies", and the greater the reward of such a watch. In a big business, failure to set up a recurring item of \$200.00 on the balance sheet may have no appreciable effect on the "net worth"; whereas, in your business an omission of \$50.00 may be a serious matter.

The capital of a business is the original investment made in the business by the proprietor and is equal to the difference between the total of all assets and the total of all liabilities at the time of the organization of the business. It is sometimes called the "original investment" or the "invested capital". This "invested capital" can be increased only by the additional investment of money in the business, and decreased only by the withdrawal of money from the business. On a balance sheet it is always shown at its original amount.

As the business is operated the earning of profit or the taking of losses will change the difference between total assets and total liabilities. Profits will increase, losses will decrease that difference. And these changes will increase or decrease the value of the original investment, although of course they do not change the investment itself. The total of this difference between total assets and total liabilities is called the "net worth" and is always stated as the "original investment" plus or minus profits or losses since the organization of the business. As long as the total "net worth" is in excess of the invested capital, the difference between these two is called a "surplus". When the total "net worth" is less than the invested capital, the difference is called a "deficit".

10. THE OPERATING STATEMENT. We now come to a second basic statement or record which is perhaps more important than the balance sheet. This record is known as the Operating Statement or the Statement of Profit and Loss. The operating statement is also called the Profit and Loss Statement because, if properly prepared, it shows the net result attained through the operation of the business over a given period of time. The most generally used periods of time are the calendar month, the quarter year, the half year, and the entire calendar year, because the division of time into these periods is more convenient from the standpoint of keeping records. The main purpose of the Operating Statement is to portray simply, accurately, and clearly the causes which resulted in the profit or the loss arrived at through operation of the business during the period.

In Fig. 1 is shown a skeleton form of Operating Statement adapted to the needs of the average service organization. The captions are self-explanatory. The problem is to arrive at proper figures to fill the blank spaces reserved for the purpose.

You will note that the statement is made up of two parts. The first or top part deals with sales, the second or lower part deals with expenses incurred while the sales in the first part were being made.

**OPERATING STATEMENT**  
MONTH OF \_\_\_\_\_ 193\_

	TOTAL	GROSS	NET	GROSS PROFIT
SALES FROM SALES AND COST ELEMENTS				
COST FROM SALES AND COST ELEMENTS				
<b>GROSS PROFIT ON SALES</b>				
ADD COMMISSION EARNED				
<b>TOTAL GROSS PROFIT AND COMMISSION</b>				
EXPENSES FROM SALES AND COST ELEMENTS				
<b>ACTUAL FOR MONTH</b>				
SOLD TIME EXPENSES				
FLIGHTS				
REPAIRS				
SALARIES				
RENT				
UTILITIES				
TELEPHONE				
POSTAGE				
TRAVEL				
ADVERTISING				
DEPRECIATION				
REPAIRS AND MAINTENANCE				
INSURANCE				
LABOR				
LESS ON ADVERTISING				
LESS ON REPAIRS				
<b>TOTAL ACTUAL EXPENSES</b>				
<b>NET PROFIT OR LOSS FOR MONTH</b>				

TO DIFFERENCE BETWEEN GROSS PROFIT AND LOSS, INDICATE AMOUNT PROFIT OR LOSS. IF PROFIT ON LOSS, INDICATE AMOUNT OF PROFIT. IF LOSS ON LOSS, INDICATE AMOUNT OF LOSS.

**RADIO SERVICE RECORD SYSTEM**

Fig. 1 Skeleton form Operating or Profit and Loss Statement.

The "gross profit and commission" item constitutes the dividing line between the two sections. "Gross profit" is the difference between the total of the sales made during the period and the cost of the material and labor or "cost of sales" that went into the goods and services that were sold. The "net profit or loss" item at the bottom of the statement is the difference between the amount of "gross profit and commission" and the total of the expenses incurred during the month. A net profit will result when the total of the expenses is less than the amount of gross profit and commission during the period. A net loss will result when the total of the expenses is more than the gross profit on the sales and commission earned during the period. The chief problem of the service organization, therefore, is to earn the greatest possible gross profit at the least possible total expense consistent with efficient operation.

Emphasis too often is placed on sales volume and it is thought that greater sales will produce a larger net profit. What is forgotten, most often, is that unless these sales, if made, result in an increase of gross profit greater than the concurring increase in expenses they will not solve the "money-making" problem. If the business does not know its "cost of goods or



service sold", it cannot truthfully state what the gross profit is. We can go further and safely say that such a business does not know whether there is any gross at all in the sales it has made.

Now let us examine the operating statement as shown in Fig. 1 and find how each item is determined. A sale is a transaction whereby the ownership of goods or benefit from service rendered or to be rendered is transferred from one person to another for a sum of money. Commercially, it seems essential that money enter into the transaction if it is to be called a sale. Note, however, that as long as "a sum of money" is the consideration, a sale is made. A sale at a profit or a sale at cost or a sale at less than cost is correctly described as a "sale". It is not necessary that the money be paid at the time the sale is made. A sale on account, that is a sale for a sum of money to be paid at a future date falls within the meaning of the term.

When contemplating the means of recording sales, we must remember to group them in two classes, namely:

1. Sales arising from service jobs, herein called "service sales".
2. Sales of merchandise apart from service jobs, called "merchandise sales".

Both service sales and merchandise sales, as you probably know from experience, again fall into three classes, according to the manner in which you collect for them. Cash or C.O.D. sales are most desirable because you receive your money at once in full, upon completion of the job or when you hand your customer his purchase. The part payment sale is the next most desirable sale because you at least get part of your money at once and a definite promise for the balance at a certain time. The sale on account is the least desirable because you do not get any money right away. Instead, you get a promise of payment at a future date.

For recording sales, you should establish three simple rules:

- Rule A. A receipt in duplicate must be made out for all cash taken in. The original must be handed to the person making the payment; you will retain the duplicate for the business and will save it carefully.
- Rule B. A cost card must be made out for each service job done no matter how small or large the job.
- Rule C. An invoice in duplicate must be made out for each sale "On Account", whether the sale is a service sale or a merchandise sale. The purchaser is to be given the original. You will retain the copy for the business and will save it carefully.

The above rules can be followed easily by using a form similar to that shown in Fig. 2. You will note that this form takes care of all "Cash Sales", "On Account" sales, and also gives the cost information. This form is made in triplicate, but on the second



community, where his weekly personal living costs are \$20.00 to \$25.00 should not put his weekly salary at \$45.00. He should be reasonable and put it at any figure between \$25.00 and \$30.00. If in the end more than that is left for him, he will get it because he owns the business. If the figure is too high at between \$25.00 and \$30.00 a week he will soon realize that fact, because after a while he will not be able to take that sum as it will not be there for the taking. Generally the weekly salary of the one-man shop operator should conform to the general wage scale of his community in comparable occupations.

In order to determine the exact cost of "direct labor" or time expended on a job, we must divide the weekly salary by the total number of working hours in a week. For instance, suppose we assume that your salary is \$24.00 a week and you work 8 hours a day for 6 days. The hourly rate for "direct labor" will be fifty cents. However, this cost cannot be assumed to be the total cost to you as stated above. To this must be added "Shop Expense Percentage" or "Overhead".

Having read as far as this, you may, if yours is a one-man organization operating from your residence, feel like passing by this paragraph. You have no shop and therefore it may seem that you cannot have shop expense. Nothing could be more incorrect, because while you may not have "shop expense" in the literal meaning of the term, you nevertheless have "shop expense" in the broader sense in which we employ the term. You unquestionably have "idle time" which is time for which the shop pays you while you do not work on any service job. This is "time cost" or "wage cost" of the business which cannot be charged to any job because there are none to which to charge it. In other words, that "idle time" or "non-productive time", because the business pays you for it as well as for your "productive time", is an expense or a cost to the business which the business aims to recover. In fact, it must recover what it pays you for your "idle time" if it is to continue its existence. There is, however, only one way in which the business can recover any of its outlays for business purposes and that is from its trade or customers. Therefore, the "idle time" as well as the "time spent on jobs" must in some way be charged to your customers if the business is to recover through its operation all it pays out. Each job done must carry its proper share of "idle time" as part of the "total service cost".

Even if you operate from your home, you must have some "shop expense" in addition to your "idle time". Don't you have a room set aside for a work shop? You need transportation to get you to and from your destination on service calls. You must have some service or test equipment, tools, soldering irons. You must use up some of your supplies in your service work. You must spend some money to get service jobs. You must use electricity for light and test purposes. In all probability, your phone is used for service calls as well as for household use.

It is safe to say that anyone who engages in the radio service business has "shop expense" whether he runs a small establishment or a large one. Possibly the "idle time" item is the

biggest of all factors in "shop expense" but never is it the only factor.

"Shop expense" is variable and the amounts applied to current jobs are always estimated, because the actual shop expense for the month is not known until after the jobs during the month have been finished, charged to the customer, and perhaps paid for by him.

The fact that "shop expense" is applied on an estimated basis, therefore, makes it necessary to make a careful estimate. Should the estimate be too low, the result will be that the "service cost" fails to recover all of the cost and expense of the business. We all know that means loss, because the charge to the customer will be too low in consequence. Should the estimate be too high the result may well be that the charge to the customer will be too high and the potential business will be lost.

The chief difficulty in your estimate of "shop expense" will be "idle time". Wages will probably be the largest single item in running the business and it is quite possible that "idle time" will be the largest single item in "shop expense".

Let us assume a few items in an imaginary service organization of the one-man variety. We will deal with only a few items of expense to simplify matters. Then we will assume that we are servicemen trying to determine what our "shop expense" probably will be for the next month, so that we may go ahead and make up our Service Job Cost cards as we do service work during the next month.

The weekly drawing account is .....	\$30.00
The monthly rent chargeable to the business is .....	15.00
The monthly use of supplies, solder wire, etc. is ....	3.00
The monthly electric bill for the business is .....	6.00
The monthly telephone bill for the business is .....	4.50
The monthly automobile expense to the business is ....	12.00

The items rent, supplies used, electricity used, telephone automobile expense are about right. We know from past experience that those expenses run about that much per month.

Wages, however, are different; \$30.00 per week for 4½ weeks (the next month has that many weeks) amount to \$135.00. The important question in regard to wages is how much of this is going to be for "idle time", not chargeable to service work directly but part of "shop expense".

There your experience can be of assistance, and thought on the matter makes you decide that out of the 216 hours, based on a 48 hour week, you will do service work 130 hours. You base that on an average of 5 hours per day which you believe you have generally spent on service work in the past. You probably wish you had kept a record of your time spent on service work in the past. That would be of very great assistance to you now.

You estimate then 130 hours out of 216 hours as productive time which leaves 86 hours as "idle time" or "shop expense". These 86 hours, at the rate of 48 hours for \$30.00 or \$.625 per hour, represent an amount of \$53.75.

A summary of "estimated shop expense" for the next month then would look as follows:

Idle Time 86 hrs. @ .625 .....	\$53.75
Rent .....	15.00
Supplies .....	3.00
Electricity .....	6.00
Telephone .....	4.50
Auto Expense .....	12.00
Total .....	\$94.25

This item of \$94.25 "estimated shop expense" you cannot charge on your Service Job Cost Card as either "time spent on job" or "materials used". Yet you must enter it as cost on your job cards so that you will not fool yourself in regard to the "cost of service" on which you base the charge to your customer in the space indicated for "services rendered".

If your estimate is correct, during the next month you will charge to "time cost" on your Service Job Cost Cards, an aggregate of 130 hours amounting to \$81.25. On top of that you will have to add \$94.25 in "shop expense".

Dividing \$81.25 into \$94.25, you will find that the latter amount is 1.16 times \$81.25.

Expressed in another manner then, we say that, based on your estimate for the next month and in order to make sure that "service cost" will include all the "time cost" and "shop expense", to each \$1.00 of "time cost" you must add \$1.16 of "shop expense". Or, "shop expense" is 116% of "time cost" which is the wage or salary cost of the estimated time you expect to put in during the next month on service jobs.

We trust that you will always be able to charge the customer more than the "cost of service" shown on your Service Job Cost Cards, because that will mean that you make a profit, in addition to recovering all your costs.

We have dealt with the "cost of service" to the business. We have not dealt with the charge that should be made to the customer because that is one of the things we cannot do for obvious reasons. As far as the charge to your customer is concerned, you must determine that for yourself and much will depend on local conditions and competition.

We could go into the question of estimating shop expense percentage in great detail, but we feel that we would only confuse you. We will, however, touch on some of the items that must be included in this estimate. The question of "idle time" has been discussed quite extensively above so we will cover other or running expenses.

1. *Floor Space.* If you use separate premises for your business, this item is easy to determine. However, if you use part of your home, you should charge your business only the percentage of total floor space that you use.

2. *Electricity and Gas.* Again, only that part of the electricity used in your business should be charged to the business. Also, in going over bills for previous months, an average for at

least 12 months should be taken, so that both winter and summer conditions will be taken into consideration.

3. *Telephone.* Remarks made above as to the percentage to be charged to the business must be considered.

4. *Other Items* that must be considered are Automobile Expense, Advertising Service Information, Depreciation of Equipment, Insurance and Taxes.

Returning to the Operating Statement, we now have all information needed except for actual expenses. These figures are taken from actual bills received for these items and are a definite check on your estimates of these expenses at the beginning of the month.

After completing this statement and deducting the expenses we find the net profit or loss for the month. Needless to say any business which operates at a loss for any long period of time is sure to fail.

In passing from the subject of the keeping of records, we would make one more recommendation. Various service organizations have sprung up for the betterment of service engineers. One of the major improvements in conditions brought about by these organizations is the standardization of charges for various services. We are giving these to you here, not as a necessary "must", but as a guide to you in establishing your business.

1. Complete adjustment of receiver including test of all tubes, check speaker adjustment, adjust trimmers, inspect aerial system, check power plug and cord, adjust and tighten knobs, but not including any material.. \$2.00
2. Same for All-Wave sets ..... 3.00
3. For changing any of the following: Fixed resistor, mica or tubular condenser, volume control, pilot light..... 1.50
4. For replacing any of the following: Tone control, porcelain resistor, dial, dial drive cable, compensating condenser, electrolytic condenser, waveband switch (1 or 2 section) ..... 1.75
5. For replacing any of the following: Audio transformer, filter choke, speaker cone, R.F. or I.F. transformer, tube socket, waveband switch (3 section) ..... 2.00
6. For replacing any of the following: Power transformer, speaker field coil, tuning condenser, waveband switch (4 or 5 section), tuning indicator ..... 2.50

Of course the charges above are for labor only and do not include material costs. Where two or more operations are performed in one service trip a composite charge should be made. For instance, two of the jobs for \$3.00 and an additional \$ .75 for each additional item.

For automobile sets, the following charges are recommended:

- |   |        |
|---|--------|
| Removing set from car where necessary and replacing it after repairs have been made ..... | \$1.00 |
| Repairing controls .....  | .75    |

Replacing control shaft .....	.75
Replacing fuse, vibrator or tube .....	.75
Replacing any of the items listed in groups 3 or 4 .....	1.75
Installing under-car aerial .....	1.00
Adding overhead speaker to existing auto radio installation .....	2.25

We have dealt quite at length with the basic elements of the bookkeeping side of the successful service shop. We feel that this one consideration, when neglected, causes more business failures than any other. We could have gone into more detail and given illustrations of many more supplementary forms which could be used. However, we feel that the forms used can be more readily designed by the service engineer to fit his individual requirements.

11. ADVERTISING. Perhaps the question has already come to your mind as to just how you can get into business for yourself, how to attract customers and how to continue holding them as customers. Our first consideration is of course the obtaining of customers as we start out in business. Of course, you could tell all your friends and relatives of your new business venture, but we fear that you would find very few customers in this manner. The only other way to attract customers is by advertising.

There are two methods of advertising; direct or indirect. Direct advertising is that type in which the prospective customer is made aware of your business, to the exclusion of all other interests, either by mail or by personal phone conversations. The latter system is seldom used by progressive businessmen, due to the doubt existing as to the mental attitude of the prospective customer at the moment he is approached. Indirect advertising is that type usually found in newspapers, magazines, and telephone directories. This type of advertising presumes the interest of your customers in seeking the services you have to offer.

In starting your business we strongly recommend the use of both direct mail and newspaper advertising. A penny postcard suitably imprinted with the announcement may be mailed to all your prospective customers. Mailing lists may be obtained from any number of sources, such as telephone directories or from any of the commercial agencies which furnish this type of information. In addition a small advertisement in your own local newspaper should be carried regularly. Your name should be listed in the classified section of your local telephone directory.

Your place of business should carry signs indicating that you are a competent service engineer. If you work from your own home, place a sign in front of your home telling those who pass by that you are a service engineer. This sign should be large enough to be readable from a passing automobile.

Never let a former customer forget you. You should keep a file of all previous customers and drop them a personal note periodically, offering your services for any needed adjustments.

At this point we would caution against the use of so-called "leaders" indiscriminately. A "leader" is an offer of bargain rates on certain services offered primarily to obtain new customers. These generally fall under the heading of "free pickup and delivery" or "no charge call". Sometimes service engineers offer a "complete checkup" at reduced rates to attract new customers. These leaders may be used infrequently, but if overdone, will give your business a poor name.

Many service engineers find themselves suddenly "out of the running" because they are not acquainted with the principles of operation of the latest type receivers. We strongly recommend that you keep up with new developments by subscribing to several technical and semi-technical magazines. We will not specify any magazines in particular, but believe you can find several designed particularly for the service engineer. In addition, we strongly advise the service engineer to provide himself with copies of service manuals covering sets manufactured in recent years. It is impossible to service a radio receiver without the circuit diagrams. These and other pertinent service information are included in these handy manuals.

12. OTHER MEANS OF INCREASING YOUR INCOME. One of the big problems in the radio servicing business is the amount of idle time usually existing in any shop. Naturally, as we explained above, the more idle time that exists, the more you must charge per hour of service time in order to "make a go" of your business. It follows, then, that if we can turn this idle time to some profitable use, the less we will have to charge off as overhead. In the following paragraphs we are going to describe several ideas designed to reduce idle time and to give your business an increase in profits. These various "ideas" are not given in any special order, but are more or less selected as representative of the many sources of revenue open to the wide awake service engineer.

#### 1. *Public Address or Portable Sound Equipment.*

Perhaps one of the most profitable "sidelines" for the average service engineer is the sound equipment field. One or several units should be kept in good working condition for almost instantaneous use. The unit or units (as the case may be) should be designed to cover a wide range of requirements; either small or large gatherings, indoors or outdoors.

There are many places where this equipment may be used, and we list below a few of them. A little wisely placed advertising plus some personal contact work will give you many extra dollars in the cash register. Such activities are:

1. Political campaigns. Party leaders of any political group are extremely good prospects for mobile sound equipment which can be mounted on a truck or passenger car. This equipment in some cases may even be sold, but is usually rented to the customer.
2. Dance orchestras are excellent customers of equipment for sound reinforcement for their vocalists.



3. Many small gatherings of social groups often desire sound equipment including a phonograph for reproduction of popular music for dancing.
4. Amateur theatricals often desire sound reinforcement, due to the lack of strength in the amateur actors' voices.
5. Recording equipment is desirable for the recording of special events in the lives of your customers.

We could continue with many items as listed above. However, the ingenuity of the service engineer will find an ample field for his services along this line.

## 2. *Lightning Protection.*

Lightning arrestor installation offers a business opportunity for the serviceman at some periods of the year. With such installation jobs running from \$2.00 to \$5.00, depending on the work involved, the radio man can open up a new market for his services and have the satisfaction of knowing he is rendering a real safeguard to the lives, property, and radio sets of his customers. A good lightning arrestor, properly installed, is definitely an essential safety precaution for the protection of any radio set from damage due to lightning. It is also a means of reducing fire hazard in the room in which the radio is located.

A good lightning arrestor is one which is listed or approved by the Board of Fire Underwriters. A properly installed lightning arrestor is one which is located as near the aerial as possible outside of the building and has a short straight lead of not less than #14 copper wire connected to ground. This ground should preferably be a water pipe on the outside of a building or a 1-inch pipe driven at least three feet into the soil.

Through many years experience in the installation and maintenance of aerials for private homes and master aerial systems for apartment houses, the following facts regarding the use of lightning arrestors have become well established as definitely essential safety precautions:

1. The use of a lightning arrestor on any outdoor or attic aerial is a worthwhile precaution to a radio set in the event of nearby lightning surges.
2. When using an antenna system of the noise-reducing type, it is an additional safety precaution to the transformers and coupling associated with the system.
3. The risk of fire due to heavy lightning surges being guided to the room by the aerial down lead is greatly reduced.

## 3. *Extra Speakers.*

Many customers like to receive their favorite radio programs in several different parts of their homes. This of course may be accomplished by using several radio receivers, but the cost is ordinarily prohibitive. Midget receivers could be used but the quality of the reception is far from satisfactory. The practical solution is the installation of several speakers connected to one central receiver. The quality of the programs from such a system

compares favorably with the reception from the original speaker, provided that reasonable care is used in matching impedances.

Since these speakers must be arranged so that any unit can be turned on or off at will, some method of providing a constant load on the receiver must be used. One method is to place all the speakers across individual potentiometers which in turn are connected in parallel across the output transformer. Various modifications of this plan are possible.

In making installations of extra speakers, care must be taken that all wiring is neat. Do not drill any unnecessary holes in the walls or woodwork. It is always better to run leads ten feet farther around a corner than to cut or drill unsightly holes in the wall. In making connections to the speakers it is wise to use a plug and jack for ease in connecting and disconnecting the various speakers.

#### *4. Connections with Local Radio Dealers.*

As a final suggestion, we strongly recommend the contacting of local radio dealers who do not have their own service departments. Many of them are more than willing to give you their business provided that they can be sure that their customers will receive satisfactory work. This applies not only to service jobs, but also to antenna installations, lightning arrestor installations, automobile receiver installations, and the setting of push-buttons of automatic tuning receivers.

The text of this lesson was compiled and edited by the following members of the staff:

G. L. Taylor  
President and Chief Engineer  
Midland Radio & Television Schools, Inc.

C. L. Foster  
Supt. of Instruction  
Midland Radio & Television Schools, Inc.

C. V. Curtis  
Chief Instructor  
Midland Radio & Television Schools, Inc.

R. E. Curtis  
Technical Drafting  
Midland Radio & Television Schools, Inc.

