

COYNE  
ELECTRICIANS  
HANDBOOK

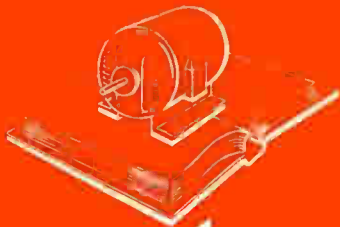


PRACTICAL  
Electrical and Radio  
Books  
for  
PRACTICAL MEN





**Coyne  
Electricians  
Handbook**



# COYNE ELECTRICIANS HANDBOOK

•

A REFERENCE and DATA BOOK

•

Formulas — Methods — Charts  
Code Rules — Diagrams, Circuits,  
Laws — Specifications — Tests,  
Emergency Repair Data — Definitions  
Design — Materials, Protection  
Plant and System Improvements, Etc.

*Compiled and Prepared by*

THE TECHNICAL STAFF  
COYNE ELECTRICAL SCHOOL  
CHICAGO

---

Copyright 1945 by

COYNE ELECTRICAL SCHOOL, CHICAGO

Printed in United States of America

# *An Acknowledgement*

---

In the preparation of this book invaluable help has been freely extended by the leading manufacturers in the electrical industries, especially by

**General Electric Co.**

**American Standards Assn.**

**Westinghouse Electric Mfg. Co.**

**Sylvania Electric Products Co.**

**Struthers Dunn, Inc.**

**National Electrical Code**

**Delta Star Mfg. Co.**

**Electric Storage Battery Co.**

to all of whom we extend our sincere thanks for technical data, relating to the installation, operation and maintenance of electrical apparatus.

## FOREWORD

ideas that save time and money for their company. This **Electricians Hand Book** is "chock-full" of practical ideas that **YOU** can offer to your employer that will save him money.

These ideas are on special tests or other time saving and money saving plans, that can be used to advantage in practically any plant having Electrical power.

Many buyers of this book have told us that one single idea alone for plant improvement outlined in detail in this book has been worth many times the cost of the book. A man in an Electrical crew today who is anxious to get ahead must have ideas.

An example, and to illustrate as our point, refer to page 229. There, you will find a complete explanation giving you all the essential wiring data for "ADAPTING INDUCTION MOTORS TO NEW OPERATING CONDITIONS." Here you will find, worked out in every detail, a complete program of the principles of Induction Motors. Now, this plan alone would be worth thousands of dollars to any employer who is faced with an equipment problem today.

This is just one of many practical plans that are presented in this book and as a buyer you have this material before you for your use.

Yes, whether you're an "old time" Electrician or a "beginner", this book can be priceless to you.

In preparing all this material, we've had the co-operation of leading Electrical and Radio companies as well as Electrical Associations throughout the country. The ma-

## FOREWORD

terial is up-to-the-minute in every possible respect and is authoritative because it has all been pre-tested by actual practical applications.

Now, I want to leave this important thought with you. Although the Coyne Electrician's Hand Book can be valuable to you every day on the job, nevertheless, if you use this book only occasionally on important Electrical or Radio problems, it can pay for itself many times over.

The value of any book isn't always regulated by how often you use it but rather how important and valuable it can be WHEN YOU NEED IT. Doctors and lawyers spend great sums for medical and law books for their library. They need these books for ready reference — so they can refer to them on certain subjects and keep themselves up to date at all times—also to refresh their memories on certain matters they cannot be expected to remember in detail. It is equally important for the Electrician or the man who is preparing for a good Electrical job to have reliable reference books for important problems that come up in his work. When you purchase a book of this kind, you are not really making a purchase—no, indeed—you are making an investment — an investment that can pay you dividends all through your life. It can be your investment for the present and for your future.

A large, stylized handwritten signature in black ink, appearing to read 'H. Lewis'. The signature is written in a cursive style with large, sweeping loops.

President  
COYNE ELECTRICAL SCHOOL

# FOREWORD

---

In judging the value of any handbook or Electrical Manual the thought to keep foremost in mind is—who published it and what experience have these publishers had in the subjects covered?

2730  
This book was developed by the Technical Staff of the Coyne Electrical School. One way it differs from any other Handbook is that instead of being written by ONE man it represents the combined efforts of the Coyne Technical Staff in collaboration with leading electrical manufacturers and electrical associations throughout the country.

2/1/51  
For many years there has been a definite need of one single book which combines the essential formulas, charts, tables, code rules and interpretation, wiring methods, etc., for the practicing Electrician.

There are many books that contain material on one or two of these subjects, but up until now there has not been a book that includes all of the material on all of the subjects. The Coyne Electricians Handbook is such a book — really many books in one.

In preparing the material for this book the thought that was kept foremost in mind was to condense the explanation and to include as much material as possible that would be of practical value to the Electrician on the job or the beginner in the Electrical field.

In addition, any explanation of a law, rule, formula or definition was put in the plainest



## FOREWORD

and simplest of Electrical terms. You will note as you study and use the **Coyne Electricians Handbook** that complicated Electrical explanations have been put into clear, understandable language.

### **YOU CAN USE THE COYNE ELECTRICIANS HAND BOOK EVERY DAY ON THE JOB**

There's hardly an Electrical job that comes along but what this practical book can save you time and worry. Just refer to the right formula, rule, table, chart or wiring method and there's your answer all worked out for you. A **successful Electrician** — the fellow who is on top today is the man who knows the latest methods and does all of the work according to code rules. These are the men who do not "guess" on the work to be done —**THEY KNOW.**

### **THIS BOOK WILL HELP YOU "STAND OUT" IN YOUR CREW**

In addition to the **up-to-the-minute information on Electrical laws and data included in this book**, the Coyne Electrical School has also included material for plant and Electrical system improvements never before published in any book. All of these ideas have been developed and worked out in the **Coyne Training Shops** and are passed on to buyers of this book as a means of helping them advance.

In every Electrical Crew there are men who "stand out" in their work. Why do they stand out? Well, simply because they have

# CONTENTS

<b>Electric Circuits —</b>	<b>1 - 20</b>
Definitions — Resistance — Voltage drop — Circuit laws, Ohm's law Formulas, diagrams, Line Curves, Frequency, Maximum and effective Values, Single and polyphase current, Phase Relation, Inductive Reactance, Capacity Reactance, Impedance Series and Parallel Circuits, Conversion of Measurements.	
<b>Reading Wiring Diagrams —</b>	<b>21 - 40</b>
Symbols, Pictures, Switches, Definitions, Building Wiring Plans — External and Internal Diagrams, Relays, Meter Connections, Electric Range, Combination Diagrams, Telephone Circuit Diagrams.	
<b>Conductors and Wires —</b>	<b>41 - 62</b>
Definitions, Tables, Insulated Conductors, Allowable Current Carrying Capacity of Conductors, Dimensions, Wire, Voltage Drop, Flexible Cords.	
<b>Resistors and Resistance —</b>	<b>63 - 76</b>
Definitions, Alloys and Materials, Duty Cycle, Rheostat and Potentiometer Ratings, Voltage, Parallel Resistances, Current Flow, Troubles, Color Coding of Resistors.	
<b>Insulation and Insulators —</b>	<b>77 - 82</b>
Definition of Terms, Materials, Di-electric Strength, Sparking Voltage in Air, Resistivities, Insulation Resistance Tester, Testing with Voltmeter.	
<b>Wiring Methods and Material Provisions</b>	<b>83 - 130</b>
Applying to Wiring in Metal Enclosures, Rubber Covered Conductors, Conduit and Tubing, Tables, Charts, Combinations of Conductors, Raceways, Cable Assemblies, Symbols, Outlets per Circuit, Electrical Equipment in Building, Industrial types, Wire Splicing, Soldering, Solderless Pressure Types, Wire Connectors, Switch Connections for Lighting, Branch Circuits, Signal and Alarm Circuits, Grounding, High Voltage Test for Wiring Installation.	
<b>Overcurrent and Overload Protections —</b>	<b>130 - 140</b>
Definitions, Circuit Breakers, Fuses, Overcurrent Devices, Running Protection of Motors, Trip Coils, Relays, Settings of Motor Branch Circuit Protective Devices, Rating.	
<b>Magnets, Coils and Deductions —</b>	<b>141 - 152</b>
Definitions, Coils, Magnetic Circuits, Reactance and Impedance, Series and Parallel Inductances, Directions of Flux and Currents.	
<b>Capacitors, and Capacitance —</b>	<b>153 - 158</b>
Definition of Terms, Dielectric Constants, Capacitive Reactance, Testing of Capacitors, Testing Electrolytic Capacitor.	
<b>Power —</b>	<b>159 - 164</b>
Definition of Terms, Formulas, Circuits, Power and Energy Conversion Units.	

# CONTENTS

<b>Meters and Measurements —</b>	<b>165 - 182</b>
Definition of Terms, Construction and Connections, Multipliers for Voltmeters, Shunts, Alternating Current Circuits, Testing Kilo-watt-hour Meters, Wheatstone Bridge.	
<b>Transformers —</b>	<b>183 - 206</b>
Definition of Terms, Principles, Power Output, Auto-transformers, Polarity Markings, Testing Polarity, Angular Displacement, Installation, Grounding, Overcurrent Protection.	
<b>Motors —</b>	<b>207 - 260</b>
Definition of Terms, Types and Characteristics, Reversing Rotation of Motors, Motor Currents at Full Load, Wiring, Charts, Tables, Portable Motors, Horse Power Tests, Requirements for Small A.C. Motors, Checking Speed, Adopting Induction Motors to new Operating Conditions, Terminal Markings, Railway Motors, Manual and Automatic Cut-out, Stator Windings, Repulsion, High and Low Torque, Centrifugal Switch, Constant and Variable Torque, Constant Horsepower, Troubles and Remedies, Direct Current Motor Converted to Arc Welding Generator.	
<b>Generators, Converters, Rectifiers —</b>	<b>261 - 273</b>
Definitions of Terms, Troubles, Terminal Markings, 2-Wire Types, Farm Lighting Plants, Converters, Rectifiers.	
<b>Batteries —</b>	<b>274 - 282</b>
Definitions of Terms, Lead and Types, Mixing Tables, High Rate Discharge Test, Cadmium Test, Charging Rates, Dry cells, Flashlight Cells.	
<b>Switching and Control —</b>	<b>283 - 312</b>
Definition of Terms, 2, 3 and 4 Way switches, Magnetic Contactors, Motor Controls, Magnetic Motor Starters, Speed Variator, Speed Regulators, Auto and Line Starters, Dynamic Breaking, Resistors and Resistance, Installation, Wound Rotor Controls, Cam type Drum Switch.	
<b>Electric Heating —</b>	<b>313 - 318</b>
Definitions, BTU, Heating power, Air and Space Heating, Process Heating, Specific heats and Heating Power.	
<b>ILLUMINATION —</b>	<b>319 - 334</b>
Requirements, Inverse Square Law, Sodium Vapor Lamp, Candlepower, Coefficients of Utilization, Mercury Vapor Lamps, Demand Factors, Loads, Installation.	
<b>Industrial Electronics —</b>	<b>335 - 349</b>
Definitions, Photo Tubes Circuits, Bridge Rectifier, Cycles, Timing, Rectification Welding Control, Amplification.	

---

The detailed itemized index is located at the back of this book starting on page 349. This index is a classified directory telling you where over 600 SPECIFIC SUBJECTS CAN BE FOUND. We furnish both the table of contents and the itemized index for your convenience.

---

# ELECTRICIANS' HANDBOOK

## Section 1

### ELECTRIC CIRCUITS

#### DEFINITIONS

**Electricity.** A general term used when referring to the energy associated with electrons at rest or in motion.

**Electron.** A small active particle of negative electricity. Some electrons are closely associated with atoms of matter, while others, called free electrons, move readily between atoms under the influence of electric or magnetic fields. It is the movement of electrons through a conductor which constitute an electric current.

**Free Electrons.** Those electrons which are free to move between the atoms of a material when acted upon by electric or magnetic forces.

**Atom.** One of the elemental particles into which all matter is divided. An atom has a nucleus consisting of electrons and protons, with additional electrons revolving around the nucleus. Each of the elements has a different number and arrangement of electrons and protons in its atoms.

**Proton.** One of the positively charged particles which, together with electrons (negatively charged particles), make up the structure of an atom.

**Molecule.** The group of atoms which constitutes the smallest particle in which a compound or material can exist separately.

**Current.** Flow of electricity in conductors. The unit of current measurement is the ampere. Current is movement of free electrons along a conductor.

**Ampere.** The practical unit of electric current flow. The movement of 6,280,000,000,000,000 electrons past a given point in a circuit in one second corresponds to a current of one ampere. When a one ohm resistance is connected to a one volt source, one ampere will flow.

**Milliampere.** An electric current of 1/1000 of an ampere.

**Microampere.** One millionth of an ampere.

**Potential.** A characteristic of a point in an electric circuit determined by its electric charge in comparison with the charge at some other reference point, thus making the point considered more positive or more negative than the reference point.

**Volt.** The practical unit of voltage. One volt will send a current of one ampere through a resistance of one ohm.

## ELECTRIC CIRCUITS

**Millivolt.** A unit of voltage equal to one thousandth of a volt.

**Electromotive Force.** The force produced within a generator, battery or other energy source, and which causes movement of electrons or electricity in an electric circuit. It is measured in volts.

**Polarity.** The quality of having two opposite charges, one negative and the other positive. In a magnetic circuit or part, the quality of having two opposite poles, one north and the other south.

**Positive.** A term used to describe a terminal having fewer electrons than normal, so that it attracts electrons in seeking to return to its normal state. Thus, electrons flow into the positive terminal of a voltage source.

**Negative.** Referring to a potential less than another potential, or to a potential less than that of the earth. A point toward which current flows in parts of a circuit external to the source. A terminal having more electrons than normal.

**Neutral.** Having electric or electrostatic potential intermediate between the potentials of other associated parts in a circuit; positive with reference to some parts while negative with reference to others. Sometimes refers to zero potential, neither positive or negative.

**Direct Current.** An electric current that flows always in the same direction in its circuit. The current may be steady or of constant value, or it may vary in strength, or there may be intervals of no current, but so long as current that does flow always moves in the one direction it is a direct current.

**Alternating Current.** An electric current which reverses its direction of flow at regular intervals many times per second.

**Pulsating Current.** A current which changes in value but not in direction. It can be considered as a direct current combined with a smaller value of alternating current.

**Circuit.** A complete path over which an electric current can flow.

**Series Circuit.** A connection in which the same current must flow through all of the series-connected parts.

Fig. 1-1 shows a generator and 4 lamps connected in series. The devices are connected one after the other along the wire or line, and the same current must pass through them all. So the current will be the same in all parts of a series circuit. This current is of course governed by the total resistance of all the devices in the circuit, as well as the voltage applied.

## ELECTRIC CIRCUITS

To find the total resistance of a series circuit, add the resistances of all the devices in the circuit.

In the case of Fig. 1-1, where there are 4 lamps of 40 ohms each, the total is 160 ohms.

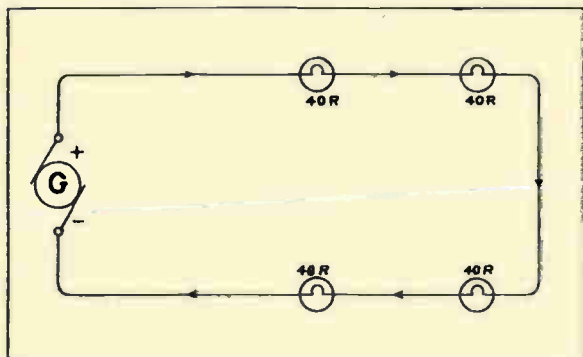


Fig. 1-1. Four lamps connected in series to a generator. Total resistance of lamp circuit 160 ohms.

In a series circuit (1) the current is the same in all parts of the circuit, (2) the total resistance is equal to the sum of the resistances of all the parts, (3) the applied voltage or the circuit voltage is equal to the sum of the voltage drops across the several parts of the circuit.

**Parallel Circuit.** A connection of two or more circuits or parts between the same terminals of a source or current-supply circuit so that the same voltage difference is applied to all parts so connected and so that the current through each is proportional to the overall voltage and the resistance of the individual parts. The total current is equal to the sum of the currents in all the connected circuits or parts, and the total resistance or the effective resistance of all the parts in parallel is less than the individual resistance of any one of them.

**A Parallel Circuit is one in which the current has two or more paths through which it can flow.** In such circuits the current from the generator or source divides, and part flows through each of the branches of the circuit according to their resistances.

Fig. 1-2 shows a generator and four lamps connected in parallel. Sometimes such a circuit is called a multiple circuit.

**Resistance of Parallel Circuits.** If the total resistance of a parallel connection gets less as we add more paths, then we see we cannot get the correct total resistance of all paths, by adding their separate resistances.

## ELECTRIC CIRCUITS

If the parallel paths are of unequal resistance proceed as follows:

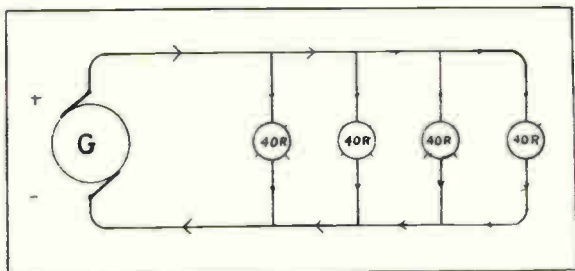


Fig. 1-2. Four lamps in parallel. Note how the current divides through each path.

1. Multiply together the resistances of two of the paths, in ohms.

2. Add the resistances of the same two paths, in ohms.

3. Divide the product found in the first step by the sum found in the second step. This gives the resistance in ohms of these two paths.

4. If there are additional paths in parallel with the first two, consider the parallel resistance of the two paths as though it were that of a single path.

5. Then take one additional parallel path, divide the product of the resistances by their sum, and thus find the parallel resistance of the first two paths combined with the third.

6. Continue thus for any additional number of parallel paths; considering one more each time, and calculating the parallel resistance when this extra path is combined with those for which a single resistance has previously been calculated.

In a parallel circuit (1) the total current is equal to the sum of the currents in the several paths, (2) the total resistance is less than the resistance of any one path, (3) the same voltage is applied to all the paths or elements which are in parallel.

**Series-Parallel.** Descriptive of a circuit or part of a circuit in which some parts or elements are connected together in series, with these series groups connected together in parallel; or parts connected in parallel and the groups in series.

## RESISTANCE

**Resistance.** The opposition which a device or material offers to the flow of direct or alternating current. The opposition which results in production of heat in the material carrying the current. Resistance

## ELECTRIC CIRCUITS

is measured in ohms, and is usually designated by the letter R.

**Ohm.** The unit of electrical resistance. The resistance of a device is one ohm when a d.c. voltage of one volt will send a current of one ampere through that device. The Greek letter omega ( $\omega$  or  $\Omega$ ) is commonly used to represent ohm.

**Megohm.** A resistance of one million ohms.

**Resistivity.** The resistance in ohms which a unit cube of a material offers to the flow of electric current.

**Specific resistance** of various common materials, at 0 degrees centigrade is shown by accompanying table.

### SPECIFIC RESISTANCES

MATERIALS	Specific resistance in Centimeter cube	Michroms. Inch cube
Silver (Annealed) .....	1.49	.587
Copper (Annealed) .....	1.59	.627
Copper (Hard) .....	1.62	.638
Gold .....	2.20	
Aluminum .....	2.61	
Zinc .....	5.38	
Phosphor Bronze (Commercial) .....	8.48	3.34
Bronze .....	17.80	
Platinum (Annealed) .....	8.98	3.54
Nickel (Commercial) .....	9.90	
Steel (Soft) .....	11.80	
Steel (Wire) .....	13.50	
Steel (Hard) .....	45.60	
Iron (Pure) .....	8.85	
Iron (Wrought) .....	13.80	5.45
Iron (Cast-soft) .....	74.40	
Lead .....	19.80	
German Silver .....	33.10	
German Silver Wire .....	20.90	8.24
Mercury .....	94.07	
Water (Ordinary) .....	1200. to 12,000.	
Carbon .....	400. to 1150.00	
Carbon (Arc) .....	5100. to 7600.00	

**Voltage Drop.** A difference in voltage due to flow of current between two points separated by resistance in conductors; equal to the current in amperes multiplied by the resistance in ohms through which the current flows.

**IR Drop.** The voltage drop developed across a resistance by the flow of current through the resistance.

**Ohmic Drop.** Potential difference due to flow of direct current through resistance.

**Ohmic Resistance.** The resistance in ohms which a part or circuit offers to the flow of direct current.



## ELECTRIC CIRCUITS

**Internal Resistance.** The resistance of conductors inside some electrical equipment or device; the resistance of the device or equipment measured between its terminal connections. The resistance of conductors through which currents flow inside a battery, generator or motor.

### CIRCUIT LAWS

**Ohm's Law.** A fundamental electrical law which expresses the relationship between voltage, current, and resistance in a direct current circuit, or the relationship between voltage, current and impedance in an a.c. circuit. The three forms of the law in each case are given below, in which  $E$  is the pressure in volts,  $I$  is current in amperes,  $R$  is resistance in ohms and  $Z$  is impedance in ohms.

#### D.C. FORMS

$$E = I \times R$$

$$I = E \div R$$

$$R = E \div I$$

#### A.C. FORMS

$$E = I \times Z$$

$$I = E \div Z$$

$$Z = E \div I$$

### OHM'S LAW FORMULAS

From the simple relationship between the size of the units and the discovery of the effect of pressure and resistance, we obtain the following formulas called **Ohm's Law Formulas**.

$$I = \frac{E}{R}, \quad E = I \times R, \quad R = \frac{E}{I}$$

In which:

$I$  = current in amperes.

$E$  = pressure in volts.

$R$  = resistance in ohms.

#### Simplified Ohm's Law Formula

A very simple way to remember all three of these formulas in one is shown by the following figure:

$$\frac{E}{I \times R}$$

All that is necessary is to cover the one you wish to find and the remaining 2 factors show you what to do, if you know their values. For example if you know the current and resistance of a circuit and wish to find the voltage, cover  $E$  and the parts still shown indicate to multiply  $I \times R$ . Or if you know the voltage and resistance and wish to find the current, cover  $I$  and do as indicated by the remaining two or divide  $E$  by  $R$ .

## ELECTRIC CIRCUITS

**Kirchoff's Current Law.** A fundamental electrical law which states that the sum of all the currents flowing to a point in a circuit must be equal to the sum of all the currents flowing away from that point.

**Kirchoff's Voltage Law.** A fundamental electrical law which states that the sum of all the voltage sources acting in a complete circuit must be equal to the sum of all the voltage drops in that same circuit.

### ALTERNATING CURRENT

The development or generation of alternating-current voltage is shown in Fig. 1-3. At the left of this figure is a sketch of a simple two-pole generator in which the progress of the conductor throughout one revolution is shown in eight steps of  $45^\circ$  each. The successive values of voltage which will be induced in this conductor are plotted or projected along a horizontal base-line at the right side of the figure.

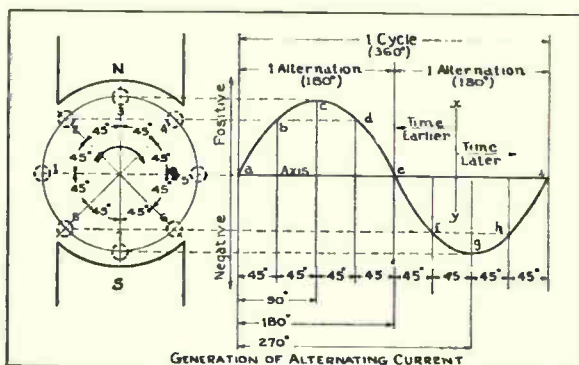


Fig. 1-3. The above diagram illustrates the manner in which alternating voltage is produced in a simple two-pole generator. The sine curve shows the variations and reversal of voltage for one revolution of the armature.

**Sine Curves; Alternation, Cycle, Frequency.** If we connect the points a, b, c, d, e, f, g, h, and i all together with a curved line, that line will form what is known as a sine curve. This curve gives us a clear mental picture of the manner in which the voltage varies in amount or value and reverses in direction in an alternating-current circuit.

The values from "a" to "e" are all positive and constitute  $180^\circ$ , or one alternation. The values from "e" to "i" form the negative alternation. These two successive alternations, one positive and one negative, complete one cycle.

## ELECTRIC CIRCUITS

**Cycle.** One complete reversal of an alternating current, including a rise to a maximum in one direction, a return to zero, a rise to a maximum in the other direction, and another return to zero. The number of cycles occurring in one second is the frequency of an alternating current. The word cycle is commonly interpreted to mean cycles per second, in which case it is a measure of frequency.

**Kilocycle.** One thousand cycles but commonly interpreted as 1,000 cycles per second.

**Megacycle.** One million cycles per second.

**Alternation.** One-half of a cycle of alternating current, during which the current rises from zero to maximum value and returns to zero.

**Frequency.** The number of complete cycles per second which an electric current undergoes.

**Period.** The length of time required for one complete cycle of alternating current or voltage. As an example, the period for 60 cycles per second is  $1/60$  second.

**Sine Wave.** The rise, fall and reversal of an alternating current or voltage which would be induced in a conductor rotating at constant speed in a uniform magnetic field and moving around a circle in that field. The ideal form of an alternating wave.

### MAXIMUM AND EFFECTIVE VALUES OF ALTERNATING CURRENT

Fig. 1-4 at A shows a curve for one complete cycle of single-phase alternating voltage, and at B shows a curve for the current that we will assume is caused to flow by that same voltage cycle.

By actual test we find the heat produced by the A.C. circuit is about 70%, or to be more exact .707 of that produced by the D.C. circuit.

We therefore say that the effective voltage and current values of an A.C. circuit are .707 of the maximum values. It is this effective value that we consider in ordinary work and calculations with A.C. circuits. Ordinary A.C. voltmeters and ammeters are calibrated to read the effective values and not the maximum values.

One of the most important points to be considered, however, is that to produce a given effective voltage in an A.C. circuit, the maximum voltage for its short periods during each alternation will be considerably higher than the effective voltage registered by the meter. This places a higher voltage strain on the insulation of an A.C. circuit of a given effective voltage value, than on a D.C. circuit of the same voltage.

When either the maximum or effective value of an

## ELECTRIC CIRCUITS

A.C. circuit is known, the other can be found by one of the following formulas:

$$\text{Effective value} = \text{Max. value} \times .707$$

$$\text{Maximum value} = \text{Eff. value} \div .707$$

The above formula for finding maximum value can be changed to read:

$$\text{Max. value} = \text{Eff. value} \times 1.414$$

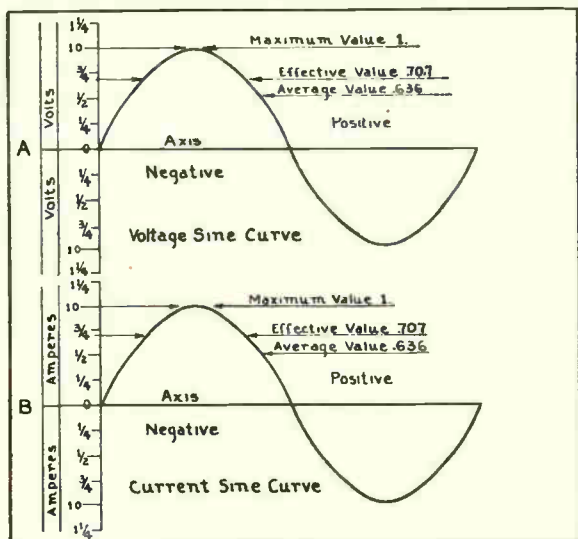


Fig. 1-4. These sketches show the maximum, effective, and average values of alternating voltage and current.

**Maximum Value.** The greatest value reached by an alternating voltage or current during any instant in the cycle.

**Peak.** The maximum instantaneous value of a varying voltage or current.

**Instantaneous Value.** The voltage, current or other value at some instant of time in a circuit wherein the voltage or current is continually changing, as with alternating current.

**Effective Current.** That value of alternating current which will cause the same heating effect as a given value of direct current. For sine wave alternating currents, the effective value is approximately seven-tenths of the peak value.

**R.M.S.** Root mean square value, which is the effective value of an alternating current. It corresponds to the equivalent direct current value which will produce the same heating effect. Unless other-

## ELECTRIC CIRCUITS

wise specified, alternating current values are always r.m.s. values.

**Average Value.** A voltage or current found by adding together a large number of instantaneous values and dividing by the number of values. In an alternation of sine wave form the average value is 0.636 times the maximum value.

### SINGLE-PHASE AND POLYPHASE CURRENT

Fig. 1-5 shows three sets of curves for single-phase, two-phase, and three-phase circuits. The single-phase curve at "A" has successive alternations of  $180^\circ$  each. The two-phase circuits have two sets of alternations occurring  $90^\circ$  apart; that is, they start, reach their maximum values, and finish always  $90^\circ$  apart. Three-phase circuits have three sets of alternations,  $120^\circ$  apart, as shown at "C" in the figure.

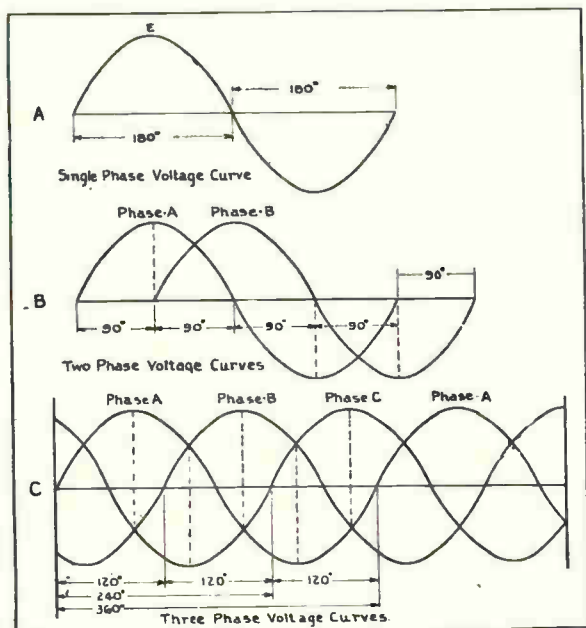


Fig. 1-5. The above diagram shows the sine curves for single-phase, two-phase, and three-phase alternating voltages.

## ELECTRIC CIRCUITS

### PHASE RELATIONS OF VOLTAGE AND CURRENT

The voltage and current of an A. C. circuit can both be shown in the same diagram by separate sets of curves drawn along the same zero or axis line, as shown in Fig. 1-6. This figure shows the curves for a three-phase circuit. The solid lines represent the voltage impulses and the dotted lines represent the current impulses.

In this diagram the current value is shown to be slightly less than the voltage value by the lower height of the curves; but the current alternations are in phase or in step with the voltage alternations. In other words, the current and voltage alternations of each phase start together, reach their maximum values together, and finish together.

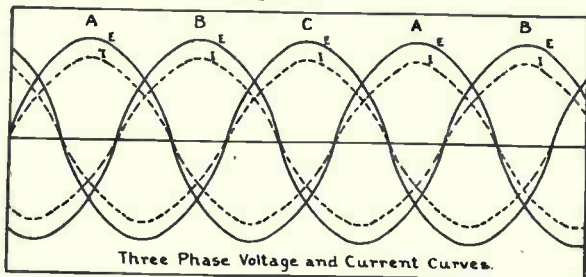


Fig. 1-6. Voltage and current curves of a three-phase circuit. The voltage is shown by the solid lines and the current by the dotted lines.

It is possible, however, to have the current impulses occur out of phase with the voltage impulses in A. C. circuits, due to the effects of inductance or capacitance in these circuits.

The current may either lag or lead the voltage, according to whether the inductance or capacitance is greatest in the circuit.

**Phase.** In alternating current or voltage, the portion of a cycle or period through which the current or voltage has passed since going through zero value at the beginning of the cycle or period. The position of the current or voltage is specified in degrees, of which 360 compose a complete cycle or period.

### INDUCTIVE REACTANCE, CAPACITY REACTANCE, and IMPEDANCE

The effects or opposition offered by inductance and capacitance to the current and voltage of an A. C. circuit, are known as inductive reactance and capacitive reactance.

## ELECTRIC CIRCUITS

If resistance, inductive reactance, and capacitive reactance all tend to limit the current flow in A. C. circuits.

The total opposition offered to the flow of current in an A. C. circuit, is called impedance. The impedance of an A. C. circuit therefore, compares with the resistance of a D. C. circuit.

The impedance and reactance of A. C. circuits are both measured in the unit ohm, to be comparable to the resistance in ohms.

**Reactance.** Opposition offered to the flow of alternating current by the inductance or capacitance of a part. Reactance is measured in ohms, and depends upon the frequency of the alternating current as well as upon the electrical value of inductance or capacitance. A condenser has capacitive reactance, and a coil has inductive reactance. The letter X is used to designate reactance.

**Impedance.** The total opposition which an alternating-current circuit offers to the flow of alternating or pulsating direct current at a particular frequency. Impedance is a combination of resistance and reactance, and is measured in ohms.

**Admittance.** The measure of ease with which an alternating current flows in a circuit. The reciprocal of impedance. Measured in micromhos (mhos.).

**Resonance.** The condition is a circuit whose inductive reactance and capacitive reactance are equal, allowing them to completely balance or neutralize each other and leaving only the resistance of the circuit to oppose flow of current in it.

**Series Resonant Circuit.** A circuit in which a coil and capacitor are connected in series, and have values such that the inductive reactance of the coil will be equal to the capacitive reactance of the capacitor at the desired resonant frequency. At resonance, the current through a series resonant circuit is a maximum.

**Parallel Resonant Circuit.** A circuit consisting of a coil and capacitor connected in parallel. At resonance, it offers a high impedance, so that a large value of voltage is developed across it at the frequency to which it is resonant.

**Resonant Frequency.** The frequency which produces resonance in a coil-capacitor tuning circuit. In a series resonant circuit, the largest current flow occurs at the resonant frequency. In a parallel resonant circuit, the largest voltage is developed across the circuit at the resonant frequency.

## LAWS FOR A-C CIRCUITS

**Ohms Law for A. C. Circuits.** Ohms law can be applied to an A. C. circuit by simply substituting the

## ELECTRIC CIRCUITS

ohms of total impedance for the ohms resistance used in D. C. Ohms law.

From Ohms law for D. C. circuits we learn that the current flow is determined by dividing the voltage by the resistance in ohms. Then for A. C. circuits, the current can be determined by dividing the effective voltage by the impedance in ohms. Or,

$$I = \frac{E}{Z}$$

And from this we can obtain by transposition the other two very convenient formulas:

$$Z = \frac{E}{I}, \text{ and } E = I \times Z$$

**Series A. C. Circuits.** There are four classes of series circuits commonly encountered in alternating current work. These are as follows:

- (a) Circuits with resistance only
- (b) Circuits with resistance and inductive reactance
- (c) Circuits with resistance and capacitive reactance
- (d) Circuits with resistance, inductive reactance, and capacitive reactance.

Incandescent lighting circuits and those supplying similar non-inductive equipment are considered to have resistance only. Actually these circuits have a slight amount of inductance and capacitance, but it is so small that it is negligible.

Circuits of this type can be treated similarly to D. C. circuits, because the resistance is the only opposing force to the current and therefore the resistance equals the total impedance. To determine the current flow in such circuits it is only necessary to divide the applied voltage by the resistance or impedance in ohms.

**Formula for Impedance of Resistance and Inductive Reactance in Series.** The impedance of such a circuit, with resistance and inductive reactance in series, can be calculated accurately by the following formula:

$$Z = \sqrt{R^2 + X_L^2}$$

We can obtain the impedance in ohms by squaring the resistance and inductive reactance in ohms, adding these squares together, and then extracting the square root of the sum, as shown by this formula.

In the case of the circuit shown in Fig. 1-7-A, where we have 8 ohms resistance and 6 ohms inductive reactance, our problem would be:

$$Z = \sqrt{8^2 + 6^2}, \text{ or}$$

$$Z = \sqrt{64 + 36}, \text{ or}$$

$$Z = \sqrt{100}, \text{ or } 10 \text{ ohms impedance}$$



## ELECTRIC CIRCUITS

**Resistance and Capacitance in Series.** Fig. 1-7-B shows a circuit in which a resistance and capacitance are connected in series. The resistance of 4 ohms is represented by the usual symbol and the capacitive reactance of 3 ohms is represented by the symbol for a capacitor.

The impedance of the circuit can be calculated by the use of a formula very similar to that used for the circuit in Fig. 1-7-A. The formula is as follows:

$$Z = \sqrt{R^2 + X_c^2}, \text{ or, in this case}$$

$$Z = \sqrt{4^2 + 3^2}, \text{ or}$$

$$Z = \sqrt{16 + 9}, \text{ or}$$

$$Z = \sqrt{25}, \text{ which gives 5 ohms impedance}$$

**Resistance, Capacitance, and Inductance in Series.** Fig. 1-7-C shows a circuit in which we have resistance, inductance, and capacitance all in series.

The total impedance of a circuit such as shown in Fig. 1-7-C can be more accurately calculated by means of the formula:

$$Z = \sqrt{R^2 + (X_L - X_c)^2}$$

And the final solution of the problem will be:

$$Z = \sqrt{400}, \text{ or 20 ohms.}$$

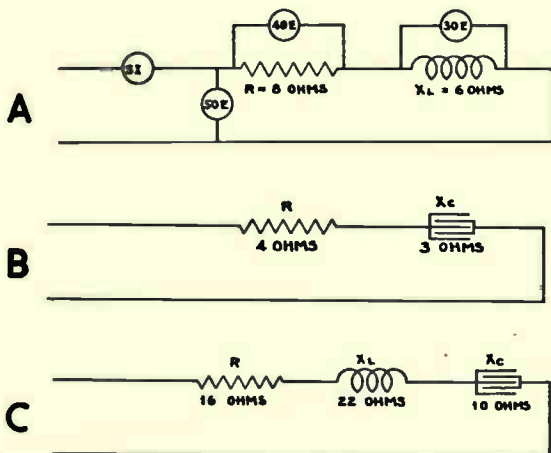
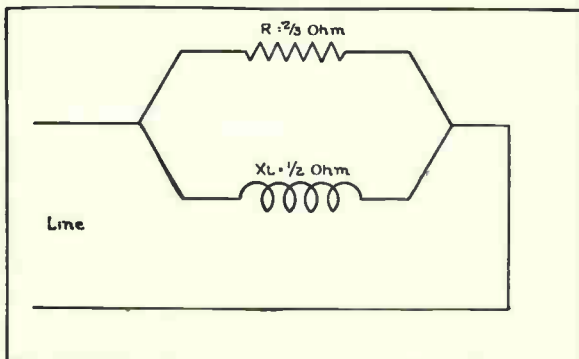


Fig. 1-7. Types of series a-c circuits.

## ELECTRIC CIRCUITS

**Parallel A. C. Circuits.** Parallel alternating current circuits are of the same four general types as series circuits. That is, they may contain resistance only, resistance and inductance in parallel, resistance and capacitance in parallel, or resistance, inductance, and capacitance in parallel.



**Fig. 1-8.** Resistance and inductance in parallel. The impedance for this circuit can be determined by the formulas given on this page.

**Resistance and Inductance in Parallel.** Fig. 1-8 shows a resistance of  $\frac{2}{3}$  ohm connected in parallel with an inductive reactance of  $\frac{1}{2}$  ohm. The total impedance of this circuit can be determined by the following formula:

$$Z = \frac{1}{\sqrt{\left(\frac{1}{R}\right)^2 + \left(\frac{1}{X_L}\right)^2}}$$

According to this formula we must first obtain the separate reciprocals of the resistance and inductance by dividing the number 1 by each of these values in ohms. These reciprocals are then squared and added together and the square root of their sum next obtained. The final step is to obtain the reciprocal of this square root by dividing the number 1 by it, as shown by the formula.

Using with the formula the values given in Fig. 1-8, the problem becomes:

$$Z = \frac{1}{\sqrt{\left(\frac{1}{\frac{2}{3}}\right)^2 + \left(\frac{1}{\frac{1}{2}}\right)^2}}$$

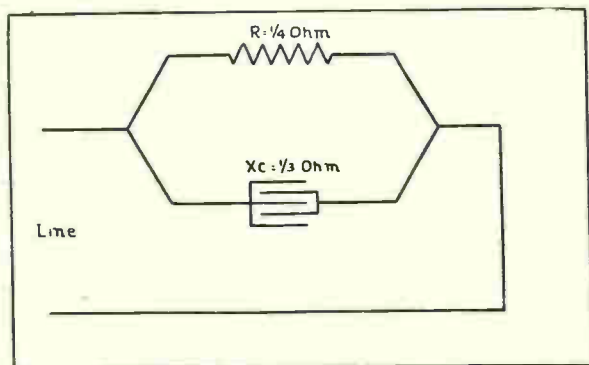
which equals  $2/5$  ohms, total impedance.

## ELECTRIC CIRCUITS

**Resistance and Capacity in Parallel.** Fig. 1-9 shows a circuit with a resistance of  $\frac{1}{4}$  ohm and a capacity reactance of  $\frac{1}{3}$  ohm, connected in parallel. The total impedance of this circuit can be determined by a formula similar to the one just used, or as follows:

$$Z = \frac{1}{\sqrt{\left(\frac{1}{R}\right)^2 + \left(\frac{1}{X_c}\right)^2}}$$

$$Z = \frac{1}{5}, \text{ or } \frac{1}{5} \text{ ohm impedance}$$



**Fig. 1-9.** Resistance and capacitance in parallel in an A. C. circuit.

**Resistance, Inductance, and Capacitance in Parallel** Fig. 1-10 shows a circuit with inductance, resistance, and capacitance in parallel.

The total impedance of this circuit can be found by the formula:

$$Z = \frac{1}{\sqrt{\left(\frac{1}{R}\right)^2 + \left(\frac{1}{X_c} - \frac{1}{X_L}\right)^2}}$$

Note the similarity between this formula and the one which was used for impedance of series circuits having inductance, resistance, and capacitance. The principal difference is merely that with parallel circuits we use the reciprocals of the values, instead of the values in ohms themselves.

You will also note that with parallel circuit problems we subtract the reciprocal of the inductive reactance from the reciprocal of the capacitive reactance, as one of these effects tends to neutralize the other, as they did in series circuits.

## ELECTRIC CIRCUITS

In the circuit shown in Fig. 1-10 the inductive reactance in ohms is larger than the capacitive reactance, but when the reciprocals of these values are obtained their relative sizes will be reversed, as shown by their subtraction in the formula.

In a circuit where the capacitive reactance might be the greater, we would reverse the order of subtraction, in order to subtract whichever reciprocal is smallest from the one that is largest.

So,  $Z = \frac{1}{\frac{1}{\frac{1}{2}} - \frac{1}{\frac{2}{3}}}$ , or  $\frac{4}{3}$  ohm impedance

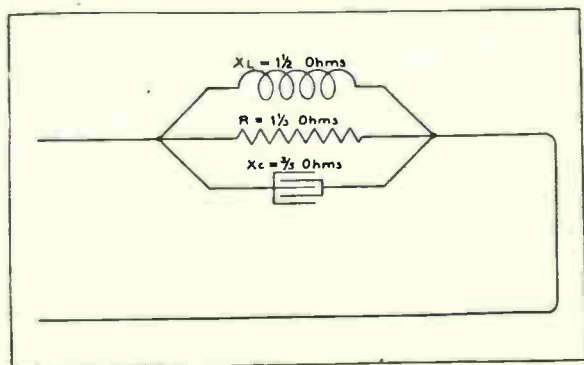


Fig. 1-10. This sketch shows inductance, resistance, and capacitance connected in parallel.

**Current in Parallel Circuits.** The current through the separate branches of the circuit, or the devices which contain the resistance, inductance, and capacitance, can be determined by the use of an A. C. ammeter, or by the use of Ohm's law formulas for each branch, as follows:

$$I = \frac{E}{R}, I = \frac{E}{X_L}, I = \frac{E}{X_C}, \text{ etc.}$$

For example, in Fig. 1-11 is shown a circuit with resistance, inductance, and capacitance in parallel. We can assume that these are a heater resistance, a transformer winding, and a capacitor all operated from the same 40-volt line. Separate tests made with an ammeter in the circuit of each device show 8 amperes flowing through the resistance or heater, 4 amperes through the inductance or transformer coil, and 2 amperes in the capacitor circuit.

## ELECTRIC CIRCUITS

By use of Ohm's law formulas, we can determine the resistance and reactance in ohms of each of these devices.

$$R = \frac{E}{I} \text{ or } R = \frac{40}{8}, \text{ or } 5 \text{ ohms}$$

$$X_L = \frac{E}{I} \text{ or } X_L = \frac{40}{4}, \text{ or } 10 \text{ ohms}$$

$$X_C = \frac{E}{I} \text{ or } X_C = \frac{40}{2}, \text{ or } 20 \text{ ohms}$$

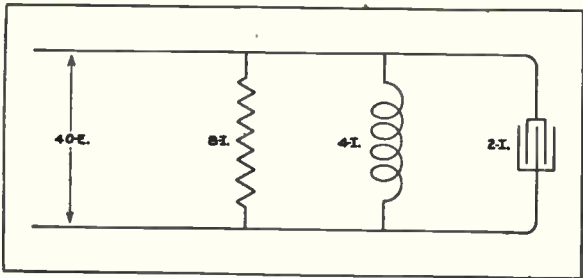


Fig. 1-11. Note the amount of current in each of the branches of the above circuit.

## CONVERSION OF MEASUREMENTS

Multiply a Measurement Given In These Units	By This Number	To Find the Equivalent Measurement In These Units
ampere-turns	1.257	gilberts
ampere-turns per inch	0.4950	gilberts per cm.
British thermal units	778	foot-pounds
British thermal units	0.000393	horsepower-hours
British thermal units	0.000293	kilowatt-hours
British thermal units	0.2928	watt-hours
Btu's per hour	0.000393	horsepower
centimeters	0.3937	inches
centimeters	0.03281	feet
circular mils	0.000005067	square centimeters
circular mils	0.000000785	square inches
cubic centimeters	0.06102	cubic inches
cubic feet	1728	cubic inches
cubic feet	7.481	gallons
cubic inches	16.387	cubic centimeters
cubic inches	0.00433	gallons
cubic meters	35.31	cubic feet
degrees, angular	60	minutes, angular
degrees, centigrade	1.8	degs. Fahr. minus 32°
degrees Fahr. minus 32°	.5556	degs. centigrade
dynes	0.00000225	pounds
feet	0.3048	meters
feet per minute	0.508	centimeters per sec.
feet per minute	0.01136	miles per hour
feet per second	30.48	centimeters per sec.
foot-pounds	0.001286	British thermal units
foot-pounds	0.00000505	horsepower-hours

# ELECTRIC CIRCUITS

## CONVERSION OF MEASUREMENTS (Cont.)

Multiply a Measurement Given In These Units	By This Number	To Find the Equivalent Measurement In These Units
foot-pounds	1.3558	joules
foot-pounds	0.0003766	watt-hours
gallons	281	cubic inches
gausses	6.452	lines per square inch
gilberts	0.7958	ampere-turns
gilberts per centimeter	2.021	ampere-turns per inch
grams	0.03527	ounces
horsepower	42.44	Btu's per minute
horsepower	550	foot-pounds per sec.
horsepower	0.7457	kilowatts
horsepower	745.7	watts
horsepower-hours	2547	British thermal units
horsepower-hours	0.7457	kilowatt-hours
inches	2.54	centimeters
inches	25.4	millimeters
inches	1000	mils
joules	0.7376	foot-pounds
joules	0.0002778	watt-hours
kilograms	2.2046	pounds
kilolines	1000	maxwells
kilometers	3281	feet
kilowatts	56.92	Btu's per minute
kilowatts	737.6	foot-pounds per sec.
kilowatts	1.341	horsepower
kilowatt-hours	3415	British thermal units
kilowatt-hours	1.341	horsepower-hours
lines per square cm.	1	gausses
lines per square inch	0.155	gausses
liters	61.02	cubic inches
liters	1.057	quarts
lumens per sq. foot	1	foot-candles
maxwells	1	lines
meters	3.281	feet
meters	39.37	inches
miles	5280	feet
miles	1.6093	kilometers
millimeters	0.03937	inches
ounces	437.5	grains
ounces	28.35	grams
quarts	57.75	cubic inches
radians	57.30	degrees
square centimeters	0.1550	square inches
square inches	6.452	square centimeters
square mils	1.273	circular mils
watts	0.05692	Btu's per minute
watts	44.26	foot-pounds per min.
watts	0.7376	foot-pounds per sec.
watts	0.001341	horsepower
watt-hours	3.415	British thermal units
watt-hours	2655	foot-pounds
watt-hours	0.001341	horsepower-hours
webers	100000000	maxwells

### CENTIGRADE AND FAHRENHEIT TEMPERATURES

#### CHANGE CENTIGRADE TO FAHRENHEIT EQUIVALENT:

1. Multiply the number of centigrade degrees by 9.
2. Divide the product by 5.
3. Add 32 degrees.

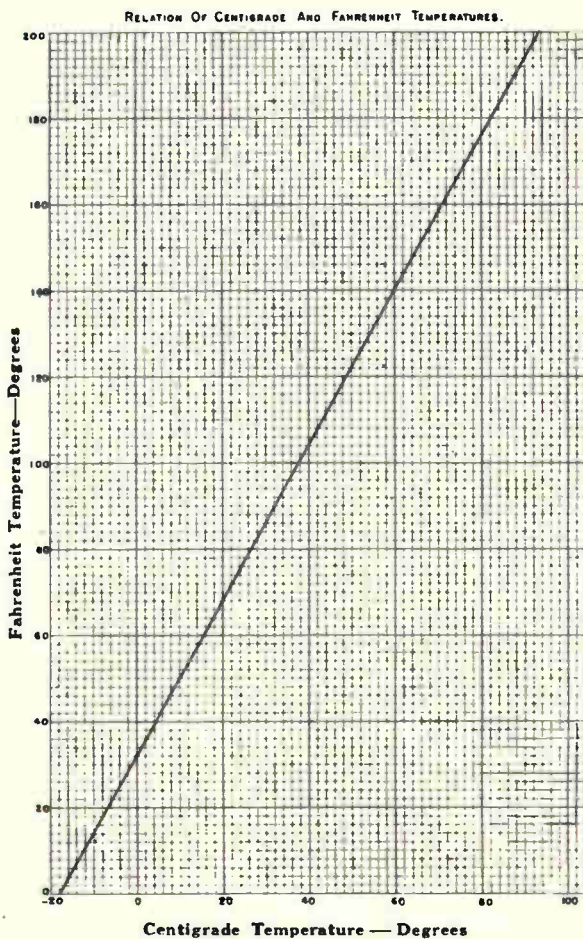
#### CHANGE FAHRENHEIT TO CENTIGRADE EQUIVALENT:

1. From the number of Fahrenheit degrees subtract 32.
2. Multiply the result by 5.
3. Divide the product by 9.

See accompanying graph for conversion of temperatures in the usual working range.

# ELECTRIC CIRCUITS

## RELATION OF CENTRIGRADE AND FAHRENHEIT TEMPERATURES



## Section 2

### READING WIRING DIAGRAMS

The language of electricity is written in electrical diagrams, and the best and quickest way to learn how to read and draw electrical diagrams is to start right in reading the kind of diagrams used by men in the electrical industry.

Instead of first trying to memorize all the little separate rules and methods that engineers use in making diagrams, then trying to fit these things together later on, it is far better to commence studying complete practical diagrams right in the beginning. Nothing could be better adapted to such study than the diagrams in this book, for they not only represent actual electrical practice, but they have been proved through constant use by hundreds of electrical men working and learning in the Coyne School shops.

### SYMBOLS AND PICTURES

Electrical diagrams show wires and other connections between separate electrical devices, such as a lamp and a switch, or may show the connections inside some electrical device, such as those inside a motor. The wires are easily shown by simple lines on the diagram, but it is not always so easy to show the connected devices, such as lamps, switches and motors. These devices might be shown with pictures, but there is a better and simpler way.

The reading of all electrical diagrams is made relatively easy by using symbols instead of pictures to represent electrical parts. A symbol is a sort of simplified picture, a kind of sign writing. The difference between symbols and pictures is shown on the following pages of symbols, where many common electrical devices are shown both ways.

A picture can show the external appearance of only one particular make or model of an electrical part, and in nearly every case fails to show how the part behaves electrically. Consider the pictures of switches shown on one of the pages of symbols. Except for the knife switches, where the working parts are exposed, any of these switch pictures might represent almost any type of switch—open circuit, closed circuit, double circuit or double throw. But the symbols for the switches indicate quite clearly how the switches work electrically, how they are supposed to open and close electrical circuits. The same differences between symbols and pictures show up with adjustable resistors and with other devices having moving parts.



## READING WIRING DIAGRAMS

### SYMBOLS

For quite a few electrical parts we have a choice of two or more symbols which mean the same thing. For instance, wires that cross without being connected may be shown in any of three ways. Some engineers and draftsmen use one method, while others use a different one—it's just a matter of personal choice.

Other examples of different symbols for the same thing occur with cells and with batteries. The shorter lines may be of the same thickness as the longer lines, or the shorter ones may be much heavier. Transformers may be shown with zig-zag lines or with loops, resistors may be drawn to look like a dovetail joint or to look like saw teeth. The meaning of a symbol is not altered by the style used, any more than the meaning of words is altered by writing them sometimes slanting, sometimes vertical, and sometimes backhand.

The man who makes the diagram may specify, usually by a note on the diagram, that certain styles of symbols have special meanings on that one diagram. For example, it might be noted that resistors shown like a dovetail indicate those constructed with cast iron "grids," and that those shown by a saw-tooth line indicate those that are wire-wound. But these are special cases and they do not alter the general meanings of the symbols.

Compared with pictures, symbols are easier to draw, are easier to recognize even though roughly or crudely drawn, and with symbols it usually is easier to follow current paths through the parts. As a consequence, practically all electrical diagrams make use of symbols.

### WHAT EACH SYMBOL MEANS





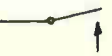
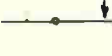


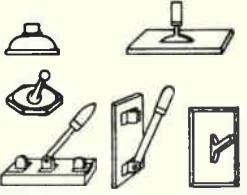
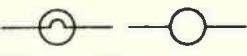

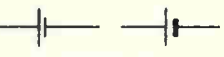

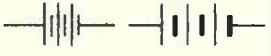


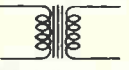
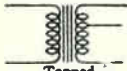
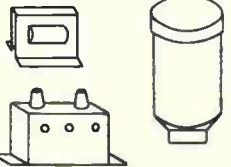
Because the symbols shown on the pages of symbols and pictures are used in so many electrical diagrams you should become well acquainted with the meaning of each of them. The following explanations tell just what each symbol signifies.

**Wires Crossing (Not Connected):** Wires which are not electrically connected together, but which must cross one another in a diagram, are shown by any of these symbols. The left-hand symbol generally is preferred, especially in engineering work, but the one at the right indicates the crossing most clearly.

**Wires Joined or Connected:** Wires which are electrically-connected together, so that current may flow from one to the other, are shown by these symbols. Note that a small black dot indicates the point of joining.

# READING WIRING DIAGRAMS

## SYMBOLS USED IN WIRING DIAGRAMS

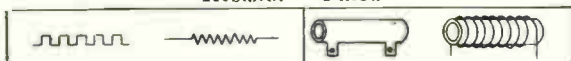
SYMBOLS		PICTURES	
Wires Crossing — Not Connected			
			
Wires Joined or Connected			
			
Switches			
 <p style="text-align: center;">Open Circuit</p>  <p style="text-align: center;">Closed Circuit</p>  <p style="text-align: center;">Double Circuit</p>  <p style="text-align: center;">Double Throw</p>			
Lamps			
			
Cells — One, of Any Type			
			
Battery — Two or More Cells			
			
Transformers — With Iron Cores			
 <p style="text-align: center;">With two untapped windings</p>  <p style="text-align: center;">Tapped winding</p>  <p style="text-align: center;">Three windings</p>			

# READING WIRING DIAGRAMS

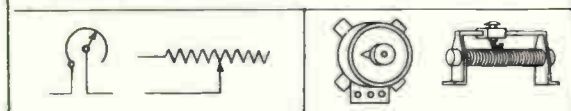
## SYMBOLS USED IN WIRING DIAGRAMS

SYMBOLS	PICTURES
---------	----------

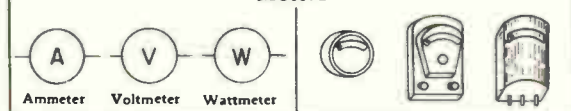
### Resistor — Fixed



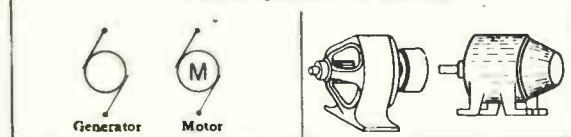
### Resistor — Adjustable or Variable — Rheostats



### Meters



### Direct-Current Machines



### Alternating-Current Machines



### Fixed Capacitor or Condenser



### Variable or Adjustable Capacitor or Condenser

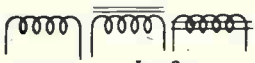



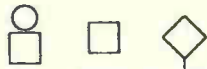





# READING WIRING DIAGRAMS

## SYMBOLS USED IN WIRING DIAGRAMS

SYMBOLS

PICTURES

Inductor, Reactor or Choke Coil	
 <p style="font-size: small; margin-top: 5px;">Air Core                  Iron Core</p>	
Ground Connection	
	
Signals	
 <p style="font-size: small; margin-top: 5px;">Bell                  Buzzer          Annunciator</p>	
Relay .	
	

**Switch, Open Circuit:** This symbol may indicate a press-button switch or other type normally held open by a spring, and closed by pressing a button or a lever. The switch opens again when the button or lever is released. The circuit in which the switch is connected normally remains open. This type may be called a normally open switch.

**Switch, Closed Circuit:** This is a switch normally held closed by a spring, and opened by pressing a button or operating a lever. The circuit in which the switch is connected normally remains closed. This type may be called a normally closed switch.

**Switch, Double Circuit:** This switch has three wire terminals, one connected to the movable blade of the switch, another to the contact point with which the blade is held in contact by a spring, and the third connected to the contact which normally is separated from the movable blade. A circuit normally remains closed between the movable blade and one contact point, and upon pressing the button or lever the connection is shifted to the other contact. This may be called a two-way switch.

## READING WIRING DIAGRAMS

**Switch, Double Throw:** This switch will connect one wire or one line to either of two other wires or lines, depending on which direction the switch handle or blade is moved.

**Lamps:** Either of these symbols may be used for any style of incandescent lamp. If some other style of lamp is to be indicated, such as a fluorescent type, a note to that effect should be made on the diagram, or else some special symbol should be used and plainly identified.

**Cells:** A cell is a single unit that produces emf and causes current to flow in a closed circuit. The longer line usually indicates the positive terminal of the cell, although this is not an invariable rule.

**Battery:** A battery consists of two or more cells which, when connected together in series as indicated by the symbol, deliver more emf or more voltage than a single cell. While the end of the battery shown by the longer line usually is considered to represent the positive terminal, it is better practice to mark the ends with plus (+) and minus (—) signs for polarity. The number of cells shown in the battery symbol does not necessarily indicate the number of cells in the actual battery. A few long and short lines may indicate any number of cells. One end of the symbol may be a long line and the other a short line, both ends may be long lines (this is good practice), or both ends may be short lines.

**Transformers:** Transformer windings may be indicated either with zig-zag lines or with loops. The zig-zag lines are preferred in commercial and industrial power and light circuits, while the loops are generally used in radio circuits. When using looped lines for the windings, one or more straight lines between the windings indicate an iron core. The absence of such straight lines means an air core. An iron core is assumed when using the symbol consisting of zig-zag lines, since power transformers always have iron cores.

**Resistor, Fixed:** A fixed resistor is one whose resistance cannot be altered while the resistor is in a circuit and is carrying current. The left-hand symbol, appearing like a dovetail joint, is the one used for resistors in commercial and industrial power circuits. The saw-tooth or zig-zag line is used for resistors in radio circuits. Provided there is no danger of confusing the resistor symbol with the one for transformer windings, the saw-tooth symbol may be used to indicate resistors in any circuit.

**Resistor, Adjustable or Variable:** An adjustable or variable resistor is one whose value in ohms, or whose resistance, may be altered while the resistor is in use and is carrying current. An adjustable resistor may

## READING WIRING DIAGRAMS

be called a rheostat. These devices are used for adjusting or varying the voltage and current going to some piece of electrical equipment or to a circuit.

**Meters:** All kinds of meters are indicated by circles within which are letters identifying the kind of meter. In addition to the symbols shown, a circle with an enclosed "F" would indicate a frequency meter, one with "WH" would indicate a watt-hour meter, one with "MD" would indicate a maximum demand meter, and so on.

**Direct-current Machines:** Direct-current generators and motors are indicated by circles which represent their commutators, and with diagonal lines which represent the brushes. Without a letter in the circle the symbol usually means a generator or dynamo, although it is common practice to place a "G" within the circle to prevent possible misunderstanding. The letter "M" within the circle indicates a motor.

**Alternating-current Machines.** An alternator or alternating-current generator is indicated by two concentric circles representing the slip rings and by sloping lines that represent the brushes or collectors. There are so many varieties of alternating-current motors that the symbol is simply a circle with the letter "M" inside. The general type of circuit, the connected wires, and other equipment in the circuit will help to identify many of these simple symbols and to avoid confusion. As an example, there would be three wire connections running to a three-phase alternating-current motor.

**Fixed Capacitor or Condenser:** An electrostatic condenser is commonly called simply a condenser. Capacitor is the better name, because there are many other kinds of condensers. The left-hand symbol, consisting of two parallel lines; is the one generally used in radio work. The right-hand symbol, indicating the interleaved plates and dielectric of the capacitor, is generally used in commercial and industrial circuit diagrams.

**Variable or Adjustable Capacitor or Condenser:** Either of these symbols indicates a capacitor whose value or whose capacitance may be altered or changed while the capacitor is working in a live circuit. Both of these symbols originated in radio work, since it is only in this and similar fields that adjustable capacitors are generally used.

**Inductor, Reactor or Choke Coil:** Any coil or winding which possesses considerable self-inductance and inductive reactance may be shown by these symbols. The looped lines are the standard symbols for inductors or coils both in power diagrams and in radio diagrams.

## READING WIRING DIAGRAMS

**Ground Connection:** A ground connection is a connection either to a conductor that leads into the earth, or to the metallic framework and supports that carry electrical equipment. Two or more ground connections shown by symbols in the same diagram are assumed to be for the same ground, so that there is a continuous conductive path between the grounds shown on the diagram.

**Signals:** The symbols for bells, buzzers and annunciators are among those most commonly found in wiring diagrams. Other signal symbols will be shown on later sheets of symbols.

**Relay:** A relay is a switch whose contacts are operated by an electromagnet in which flows current that controls the relay. The contacts are in the same or a separate circuit. Relays often are shown by an outline having the shape of the part to which wire connections are made, and on which the relative positions of terminals are clearly shown.

## SYMBOLS FOR BUILDING WIRING

The symbols on earlier pages are those generally used for diagrams in which it is possible to trace the current paths throughout the entire electrical system. They are used for schematic diagrams and for circuit diagrams. The following pages, Symbols for Building Wiring, show how the various electrical devices are indicated on diagrams for building wiring. Most of these symbols are for various kinds of outlets. An outlet is a point on a wiring system from which is taken current for lamps, fixtures, appliances, heaters, motors, or any other electrical equipment.

The names printed alongside the symbols usually indicate quite clearly just what kind of outlet is meant. However, we shall follow down through the columns of the page and explain some points which may not be entirely clear.

A Capped Outlet is an outlet provided for possible future use, but at present closed with a screwed-on plate and having no external connections. A Junction Box is a steel or porcelain enclosure within which are joints between wires from different branches or runs in the wiring system, but to which lamps and other equipment are not connected. Vapor Discharge lamps include mercury vapor and fluorescent lamps as distinguished from incandescent lamps.

A Duplex Convenience Outlet is one to which two cord plugs may be connected at the same time. Convenience Outlets in general are outlets designed to take the prongs of the plugs on flexible cords. A Switch and Convenience Outlet is one that takes one cord plug and has in the same box a switch controlling current to the plug connections.

**GENERAL OUTLETS**

	CEILING	WALL
Outlet .....	○	○
Capped Outlet .....	⊖	⊖
Drop Cord .....	Ⓚ	
Electrical Outlet—for use when confused with columns, plumbing symbols, etc. ....	ⓔ	ⓔ
Fan Outlet .....	ⓕ	ⓕ
Junction Box .....	ⓙ	ⓙ
Lamp Holder .....	Ⓛ	Ⓛ
Lamp Holder with Pull Switch .....	Ⓛ <sub>ps</sub>	Ⓛ <sub>ps</sub>
Pull Switch .....	Ⓢ	Ⓢ
Outlet for Vapor Discharge Lamp .....	Ⓥ	Ⓥ
Exit Light Outlet .....	Ⓧ	Ⓧ
Clock Outlet (Lighting Voltage) .....	Ⓛ	Ⓛ

**CONVENIENCE OUTLETS**

Duplex Convenience Outlet .....	Ⓜ
Convenience Outlet other than Duplex. 1=Single, 3=Triplex, etc. ....	Ⓜ <sub>1,3</sub>
Weatherproof Convenience Outlet .....	Ⓜ <sub>WP</sub>
Range Outlet .....	Ⓜ <sub>R</sub>
Switch and Convenience Outlet .....	Ⓜ <sub>\$</sub>
Radio and Convenience Outlet .....	Ⓜ <sub>R</sub>
Special Purpose Outlet (describe in specifications) .....	●
Floor Outlet .....	⊙

**SPECIAL OUTLETS**

Any standard symbol with the addition of a subscript letter designates some special variation of standard equipment. ○ a, b, c - etc  
Ⓜ a, b, c - etc











List the key of symbols on each drawing and describe in specifications. \$ a, b, c - etc



**SWITCH OUTLETS**

Single Pole Switch .....	\$
Double Pole Switch .....	\$ <sub>2</sub>
Three Way Switch .....	\$ <sub>3</sub>
Four Way Switch .....	\$ <sub>4</sub>
Automatic Door Switch .....	\$ <sub>D</sub>
Electrolier Switch .....	\$ <sub>E</sub>
Key Operated Switch .....	\$ <sub>K</sub>
Switch and Pilot Lamp .....	\$ <sub>P</sub>
Circuit Breaker .....	\$ <sub>CB</sub>
Weatherproof Circuit Breaker .....	\$ <sub>WCB</sub>
Momentary Contact Switch .....	\$ <sub>MC</sub>
Remote Control Switch .....	\$ <sub>RC</sub>
Weatherproof Switch .....	\$ <sub>WP</sub>


























## PANELS, CIRCUITS & MISCELLANEOUS

Lighting Panel .....	
Power Panel .....	
Branch 2-Wire Circuit — Ceiling or Wall .....	
Branch 2-Wire Circuit—Floor .....	
Indicate a greater number of wires: --- (3 wires), --- (4 wires), etc.	
Feeders. Use heavy lines and designate by number from Feeder Schedule .....	
Underfloor Duct & Junction Box — Triple System. For double or single systems eliminate one or two lines .....	
Generator .....	
Motor .....	
Instrument .....	
Transformer .....	

Controller .....	
Isolating Switch .....	

## AUXILIARY SYSTEMS

Push Button .....	
Buzzer .....	
Bell .....	
Annunciator .....	
Telephone .....	
Telephone Switchboard .....	
Clock (Low Voltage) .....	
Electric Door Opener .....	
Fire Alarm Bell .....	
Fire Alarm Station .....	
City Fire Alarm Station .....	

Fire Alarm Central Station .....	
Automatic Fire Alarm Device .....	
Watchman's Station .....	
Watchman's Central Station .....	
Horn .....	
Nurse's Signal Plug .....	
Maid's Signal Plug .....	
Radio Outlet .....	
Signal Central Station .....	
Interconnection Box .....	
Battery .....	
Auxiliary System 2-Wire Circuit .....	

For a greater number of wires designate with numerals — 12-No. 18W- $\frac{3}{4}$ "-C., or by listing in schedule.

# READING WIRING DIAGRAMS SYMBOLS FOR BUILDING WIRING

## READING WIRING DIAGRAMS

A Single Pole Switch opens and closes only one side of a two-wire line, while a Double Pole Switch opens and closes both sides. Three Way and Four Way Switches are used for controlling a single lamp or other equipment from two or more locations. An Electrolier is a lighting fixture having a number of lamps. A Circuit Breaker Switch is circuit breaker that operates automatically in case of excessive current, and that may also be operated by hand like an ordinary switch. A Momentary Contact Switch is one that makes and then quickly breaks a connection as the switch is operated.

## KINDS OF ELECTRICAL DIAGRAMS

Before commencing the actual reading of electrical diagrams you should understand that different kinds of diagrams are intended for different purposes. Some diagrams are especially helpful when you are installing and wiring electrical apparatus, while others are arranged to help you locate and remedy circuit troubles. Some diagrams show only the external wires and connections between exposed terminals of electrical parts, others show the connections inside the parts.

In this book are many diagrams of each kind. To help you recognize their particular purposes and applications we now shall examine some examples of each kind.

### EXTERNAL AND INTERNAL DIAGRAMS

Some electrical diagrams show the wires and other conductors through which electric current may flow, or should flow, as it travels from the exposed terminal screws and fastenings on each piece of electrical equipment to the exposed terminals of other pieces in the same circuit or same installation. A diagram of this general type is shown by Fig. 2-1 where you may see all the wires running between lamp outlets, switches, and other parts of the lighting installation for a small bungalow.

Other electrical diagrams show conductors and current paths through the parts which are inside some one electrical device. Diagrams of this type are shown by Fig. 2-2, where it is easy to trace the current paths through windings and contacts that are inside the relays.

In diagrams A, B and C connections from terminals O, M and C to the movable blade and the contact points are shown by broken lines. This indicates that these connections are made underneath the base of the relay. The coil or magnet connections shown by full

## READING WIRING DIAGRAMS

lines are on top of the relay base where they may be seen.

Between diagrams A and B is a list giving meanings of letters used in the diagrams. In this list the part numbered 2 is identified as a spring, otherwise it might be taken for a resistor because of the manner in which it is shown in the diagrams. Parts with which there might be some confusion or doubt always should be identified on the diagram.

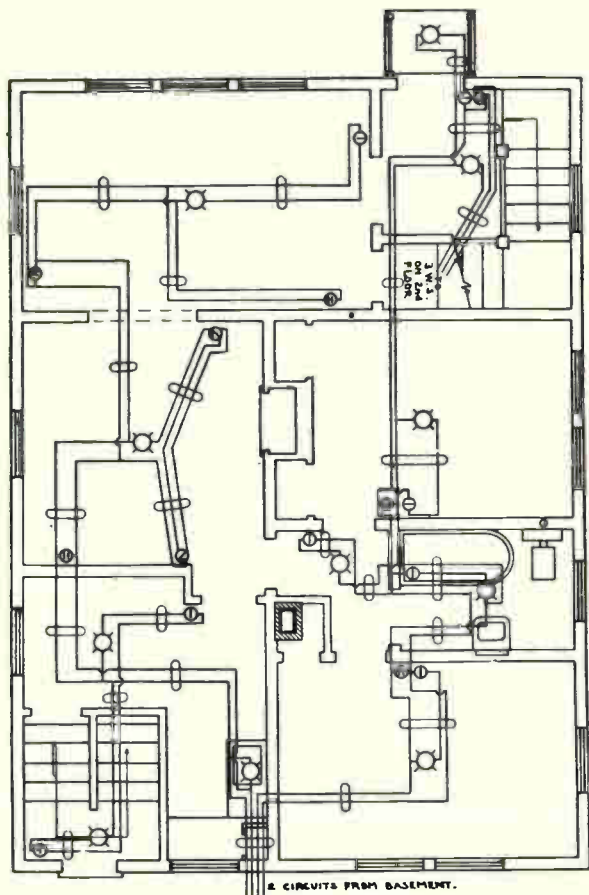
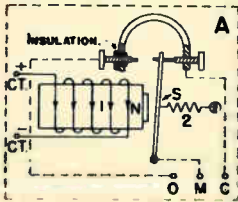


Fig. 2-1. Circuit Wiring Diagram for Bungalow.

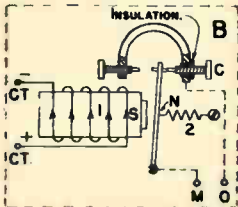
## READING WIRING DIAGRAMS

Still other diagrams show both internal and external connections, or may show the internal connections for only some of the parts, and the external con-

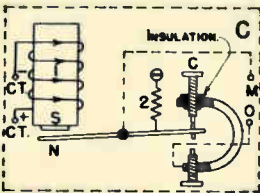


WESTERN UNION RELAY.

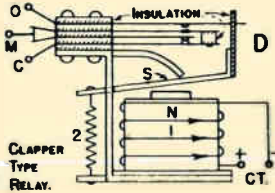
C = NORMALLY CLOSED CONTACT.  
 O = OPEN  
 M = MOVING CONTACT.  
 N = MAGNET COIL WITH TERMINALS CT.  
 2 = SPRING.



POWRY RELAY.



DIXIE RELAY.



CLAPPER  
TYPE  
RELAY.

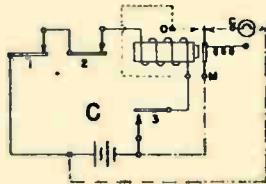
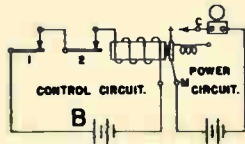
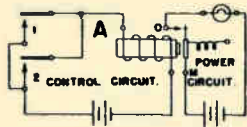


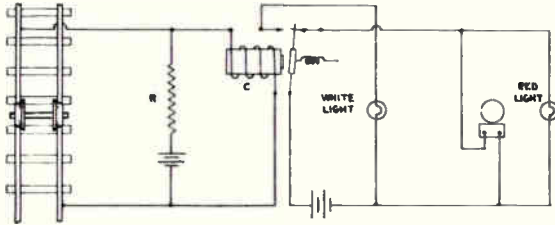
Fig. 2-2. Internal Wiring of Relays

nections between all of them. Diagrams of this class are shown by Figs. 2-3 and 2-4. The diagrams show all the external connections between all the parts, they show the internal connections inside the relays, but they do not show the internal connections for the signal bell in Fig. 2-3 nor of the motor in Fig. 2-4.

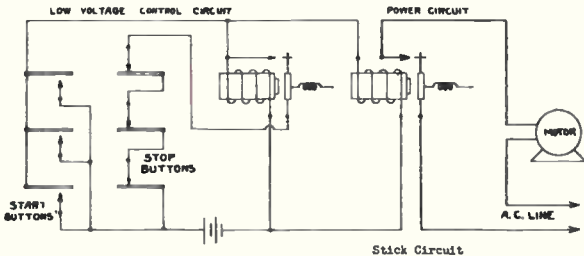
As you have just seen, it is possible to have a diagram showing only external connections, possible to have one showing only internal connections, possible to have one showing both external and internal connections, or possible to have one showing some ex-

## READING WIRING DIAGRAMS

ternal and some internal connections. The kind of diagram furnished on any job depends on what work you are to do—on whether you are to work only on the external wiring, only on the internal connections, or on both,



**Fig. 2-3.** A railway crossing alarm system including a low-resistance track circuit and a high-resistance relay circuit, with a white light for a safety signal and a red light for a danger signal.



**Fig. 2-4.** Relays for operating a motor from three different places at which there are start buttons and stop buttons. The stick circuit holds the relay for the power circuit closed until one of the stop buttons is opened.

## WIRING DIAGRAMS

When we speak of an electrical diagram as a wiring diagram we usually mean that the diagram shows exactly how wires are to be placed between electrical parts, and just where each wire is to be connected.

Fig. 2-5 shows wiring diagrams including outline shapes of a meter box and a service box. On these boxes are shown the exact positions and connections for the black or red wires (B or R) and for the white wires (W). Anyone able to use screwdriver and pliers should be able to install wiring with the help of such a wiring diagram.

Fig. 2-6 is a wiring diagram because it shows for the electric range the true relative positions of its burners, switches and other parts, and shows the actual locations of wire terminals on these parts. Were

## READING WIRING DIAGRAMS

you looking at the range itself you would find that this diagram is practically a picture of the wires and terminals.

### CIRCUIT DIAGRAMS OR SCHEMATIC DIAGRAMS

Fig. 2-7 shows two more electric range diagrams. One is marked "Circuit for Cooking Unit," the other "Circuit for Oven Unit." These are not wiring diagrams, because the heater elements, switches and connections are not in the relative positions that they actually occupy on the range. But, on these circuit diagrams, it is easy to trace the paths for electric current all the way from the three main wires marked L, N and L through the switches and through the resistors which are heating elements, and back to the main wires. This style of diagram shows the paths for current very clearly, but does not place the parts in their true relative positions. A circuit diagram, which shows electrical circuits, may also be called a schematic diagram, because, it shows the general scheme of things from the standpoint of electrical action.

It is plain that if you wish merely to check the connections of wires to the terminals of this electric range you will prefer to work with the large wiring diagram of Fig. 2-6. But should one burner fail to operate and should you wish to check the paths through which the resistor in this burner gets its current, then it will help greatly to have a circuit diagram or schematic diagram showing just how the switches operate, and just which resistors should be carrying current for each of the several degrees of heat. At least it would save much time provided you knew how to read a circuit diagram.

As a general rule the more expert and experienced the electrician the more he prefers to have circuit diagrams or schematic diagrams, and the less he depends on wiring diagrams. After getting acquainted with electrical apparatus in a general way, and when you have a particular piece of apparatus right in front of your eyes, it is not difficult to follow the wiring between exposed terminals. But no one can follow internal wiring without either taking the thing apart or having a good circuit diagram. With such a diagram it becomes easy to test for opens, high resistances, shorts and grounds by connecting your circuit tester to the exposed terminals—and to know from test indications just what is wrong inside the part on which you are working.

# READING WIRING DIAGRAMS

## PICTORIAL DIAGRAMS

Sometimes a wiring diagram is a pictorial diagram, meaning that it consists of pictures showing the external appearance of the parts and of the wiring connections between them.

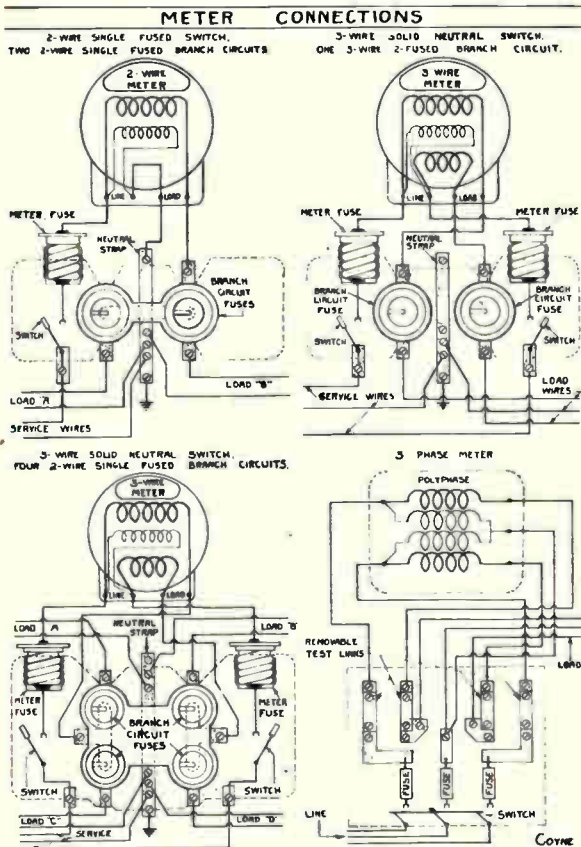
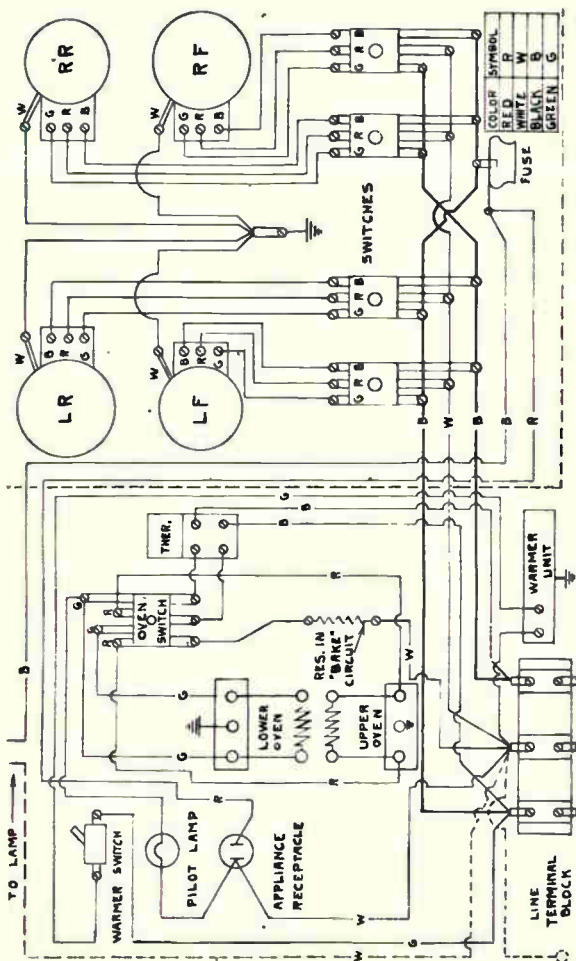


Fig. 2-5. Internal connections, service connections, and indoor branch circuit connections for meters.

nections between them. Fig. 2-8, the range installation diagram, is a pictorial diagram. This diagram shows pictures of how conduit (pipe for enclosing wires) and armored cable (flexible metal covering for wires) are to be run between the electric range, the

## READING WIRING DIAGRAMS

meter box, the switch box, the ground connection, and the outdoor service connection for the wires of the electric power company.



**Fig. 2-6.** Wiring diagram for an electric range, showing the relative positions of heating elements.



## READING WIRING DIAGRAMS

### COMBINATION DIAGRAMS

Wiring diagrams, circuit or schematic diagrams, and pictorial diagrams all have their particular uses. But often more useful than any of them is a type which we may call a combination diagram. Such a diagram is partly pictorial and partly a circuit or schematic diagram.

In Fig. 2-9 you may follow the internal connections through the windings in the symbol for a transformer, whose terminals are marked S-S-P-P, also through the electromagnet windings of the bell shown toward the right from the receiver, and you may follow the current paths through the contacts of the receiver hook switch. But internal circuits are not shown for the transmitter or mouthpiece at the extreme left-hand side of the diagram, nor for the receiver which you place to your ear, nor for the ringer magneto which is up near the line terminals at the right.

In this diagram of Fig. 2-9 we have symbols for the transformer, the battery, and the ground connection inside the magneto. We have simplified pictures for the transmitter and receiver. For the receiver hook switch, the bell, and the switch on the magneto we have a combination of picture and circuit diagram.

Excellent examples of combination diagrams are the meter connections shown in Fig. 2-5. The meters themselves are shown by outlines with the windings inside the meters shown by loops connected to terminals which are in the positions they actually occupy on the meter bases. The fuses are shown very much as they actually look, either when looking at their

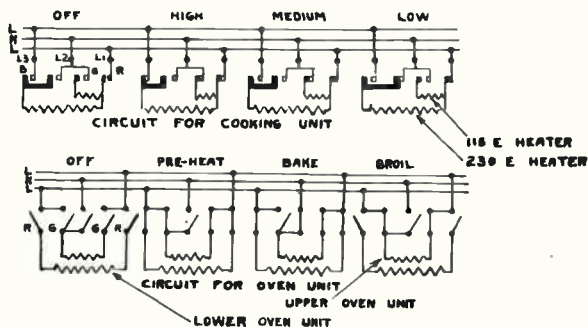
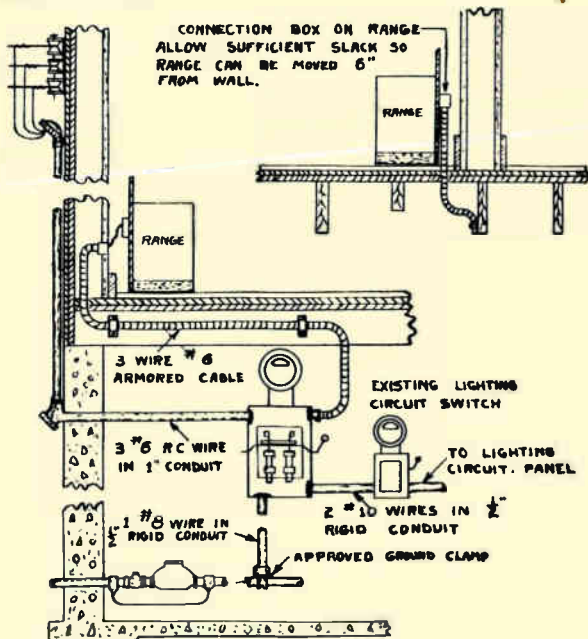


Fig. 2-7. Circuit diagrams or schematic diagrams for the electric range.

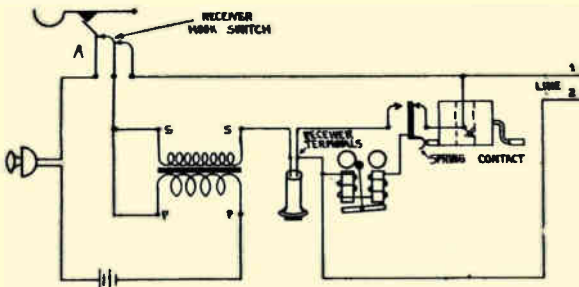
tops or their sides. The shaded parts near the fuses are the connection straps, copper bars into which thread the terminal screws for wire connections.

## READING WIRING DIAGRAMS

In these diagrams of Fig. 2-5 you have enough of a picture of the meters and the meter boxes to let you recognize every part of the actual equipment, and in addition you have all the internal wiring and the external connections so that every current path is easy to trace.



**Fig. 2-8.** Pictorial diagrams or installation diagrams for the electric range.



**Fig. 2-9.** A local battery type, silent ringing, telephone circuit.



## Section 3

# CONDUCTORS AND WIRES

### DEFINITIONS

**Conductor.** Any substance in which a difference of voltage between two points causes current to flow between these points. One or more wires carrying a single current. A wire or other metal structure which provides a path for electric current between two points. A conductor is thus a material which offers little opposition to the continuous flow of electric current.

**Non-Conductor.** Any material which offers very high opposition to the flow of electricity. An insulating material.

**Wire.** A metallic conductor having essentially uniform thickness, used chiefly to provide a path for electric currents between two points. It may be bare or covered with an insulating material such as enamel, cotton, linen or silk.

**Stranded Wire.** A wire which consists of a number of finer wires twisted together.

**Cable.** A stranded conductor (called a single-conductor cable) or a combination of conductors insulated from one another (called a multiple-conductor cable).

**Magnet Wire.** Insulated copper wire in sizes commonly used for winding coils used in electro-magnetic devices such as transformers, choke coils and relays.

**B. & S. Gauge.** Brown and Sharpe wire gauge, the standard gauge used in the United States to specify wire sizes.

**Copper Wire Tables.** Following tables list diameters, cross sectional areas, resistances, and other information relating to bare copper wires of gauge numbers from 0000 to 40 and for larger sizes which are specified according to their areas in circular mils up to 2,000,000 CM.

Note that resistances are given for certain temperatures. Resistances will be less at lower temperatures and greater at higher temperatures. Resistances at temperatures other than those listed may be calculated in accordance with instructions under the heading of "Resistance Calculations" in this section. Resistances of materials other than copper may be calculated from data on mil-foot resistances given under the same heading.

CONDUCTORS AND WIRES  
STANDARD ANNEALED COPPER WIRE  
TABLE

B. & S. American Wire Gauge No.	Diameter in Inches	Area Circular Mils	Ohms at 68 deg. Fah.			Feet		Pounds			B & S. American Wire Gauge No.
			Per 1,000 Ft.	Per Mile	Per Pound	Per Pound	Per Ohm	Per 1,000 Ft.	Per Ohm	Per Mile	
0000	0.460	211600.	0.04906	0.25903	0.000877	1.50122	20497.7	646.51	12987.	3388.	0000
000	0.40964	167805.	0.06186	0.32664	0.00012	1.9687	15255.27	507.95	8533.	2680.	000
00	0.3648	133079.	0.07861	0.41187	0.00019	2.4824	12891.57	462.83	5263.	2136.	00
0	0.32486	105534.	0.09631	0.51909	0.00031	3.1583	10223.08	319.45	3223.	1680.	0
1	0.2893	82694.	0.12404	0.65490	0.00049	3.94714	8167.49	253.34	2941.	1348.	1
2	0.25763	66373.	0.1563	0.8258	0.00078	4.97722	6429.58	200.91	1252.	1050.	2
3	0.22942	52634.	0.19723	1.0414	0.00125	6.2795	5098.91	159.32	800.	840.	3
4	0.20431	41745.	0.24869	1.313	0.00198	7.9141	4843.9	129.35	505.	665.	4
5	0.18194	33162.	0.31361	1.655	0.00314	9.97963	3206.91	196.20	316	526.	5
6	0.16202	26251.	0.39546	2.088	0.00499	12.5847	2542.89	164.62	200.	420.	6
7	0.14428	20817.	0.49871	2.633	0.00797	15.8696	2015.51	130.013	126.	333.	7
8	0.12846	16316.	0.6329	3.3	0.0125	20.0097	1599.3	99.976	80.	264.	8
9	0.11443	13094.	0.7892	4.1	0.0197	25.229	1268.44	80.655	59.	209.	9
10	0.10189	10382.	0.9441	4.4	0.0278	31.8212	1055.66	61.426	37.	166.	10
11	0.090742	8234.	1.254	5.4	0.0501	40.1202	797.649	44.924	26.	132.	11
12	0.080808	6530.	1.590	6.3	0.079	50.5906	632.533	39.766	13.63	103.	12
13	0.071961	5178.	1.995	8.4	0.127	63.7948	501.63	33.674	7.97	82.9	13
14	0.064084	4167.	2.504	11.2	0.200	80.4415	397.822	24.435	5.08	65.5	14
15	0.057068	3257.	3.173	14.7	0.320	101.4365	318.482	19.859	3.12	52.1	15
16	0.05082	2583.	4.001	19.	0.512	127.12	250.184	14.819	1.93	41.3	16
17	0.045237	2048.	5.04	26.	0.811	161.22	198.409	11.199	1.23	32.7	17

CONDUCTORS AND WIRES

STANDARD ANNEALED COPPER WIRE  
TABLE

B. & S. American Wire Gauge No.	Diameter in Inches	Area Circular Mils	Ohms at 68 deg. Fah.			Feet		Pounds			B. & S. American Wire Gauge No.
			Per 1,000 Ft.	Per Mile	Per Pound	Per Pound	Per Ohm	Per 1,000 Ft.	Per Ohm	Per Mile	
18	0.940363	1674.	6.36	33.	1.29	263.374	157.35	4.916	0.775	36.0	18
19	0.83509	1268.	8.73	45.	2.11	256.468	124.777	3.999	0.673	36.6	19
20	0.831961	1021.	10.12	53.	3.27	323.399	96.9533	3.004	0.303	16.3	20
21	0.628462	610.	12.76	68.	5.20	467.815	76.473	2.452	0.192	12.9	21
22	0.625347	642.	15.23	85.	8.25	514.193	63.336	1.945	0.119	10.24	22
23	0.622571	500.	20.30	100.	13.3	642.452	49.3504	1.543	0.073	6.13	23
24	0.6201	464.	25.60	121.	20.9	817.688	36.1365	1.223	0.047	3.44	24
25	0.6179	326.	32.2	170.	33.2	1031.038	31.0381	0.9099	0.030	3.13	25
26	0.61594	254.	40.7	214.	52.9	1300.180	24.6151	0.7602	0.0167	4.06	26
27	0.614195	201.	51.3	270.	84.2	1639.49	19.5191	0.6099	0.0110	3.23	27
28	0.612641	159.6	64.8	342.	124.	2067.364	15.4793	0.4637	0.0074	2.36	28
29	0.611257	126.7	81.6	432.	212.	2666.959	12.2834	0.3835	0.0047	2.03	29
30	0.610025	100.3	103.	536.	330.	3287.064	9.7358	0.3002	0.0029	1.61	30
31	0.608920	79.7	129.	685.	509.	4414.49	7.72143	0.2412	0.0018	1.27	31
32	0.60795	63.	154.	865.	656.	5225.915	6.12343	0.1913	0.0011	1.01	32
33	0.60708	50.1	206.	1033.	1357.	6590.41	4.85575	0.1317	0.00076	0.803	33
34	0.606304	39.74	260.	1309.	2166.	8312.8	3.94966	0.1204	0.00046	0.534	34
35	0.605614	31.5	328.	1620.	3821.	10461.77	3.05305	0.0956	0.00028	0.504	35
36	0.605	25.	414.	2200.	5466.	13214.10	2.4217	0.0737	0.00018	0.400	36
37	0.604433	19.8	523.	2753.	8742.	16629.97	1.92086	0.06003	0.00011	0.317	37
38	0.603965	15.72	660.	3464.	13772.	21013.25	1.52292	0.04758	0.00007	0.231	38
39	0.603531	12.47	822.	4395.	21906.	26496.227	1.20777	0.03755	0.00004	0.190	39
40	0.603144	9.86	1049.	5542.	28623.	33426.63	0.97964	0.02992	0.000029	0.130	40

# CONDUCTORS AND WIRES

## COPPER WIRE TABLE

From National Electrical Code

AWG	CM	Ohms Per 1000 Feet 15°C.-59°F.	Bare Conductor		Concentric Lay Stranded Conductors. Rubber, Paper, Asbestos, Varnished Cambric, Asbestos Varnished Cambric	
			Diam. Inches	Area Sq. Ins.	No. of Wires	Diam. Each Wire Inches
14	4,107	2.475	.064	.003	7	.024
12	6,530	1.557	.081	.005	7	.030
10	10,380	.9792	.102	.008	7	.038
8	16,510	.6158	.128	.013	7	.048
6	26,250	.3872	.184	.026	7	.061
5	33,100	.3071	.213	.035	7	.068
4	41,740	.2436	.232	.042	7	.077
3	52,630	.1931	.261	.053	7	.086
2	66,370	.1532	.292	.067	7	.097
1	83,690	.1215	.332	.087	19	.066
0	105,500	.09633	.375	.110	19	.074
00	133,100	.07639	.419	.138	19	.083
000	167,800	.06058	.470	.173	19	.094
0000	211,600	.04804	.528	.219	19	.105
	250,000	.04147	.594	.276	37	.082
	300,000	.03457	.641	.323	37	.090
	350,000	.02963	.688	.370	37	.097
	400,000	.02592	.734	.423	37	.104
	500,000	.02074	.828	.540	37	.116
	600,000	.01729	.892	.628	61	.099
	700,000	.01481	.968	.735	61	.107
	750,000	.01382	1.000	.785	61	.110
	800,000	.01296	1.031	.835	61	.114
	900,000	.01153	1.094	.938	61	.121
	1,000,000	.01036	1.172	1.039	61	.128
	1,250,000	.00829	1.290	1.320	91	.117
	1,500,000	.00692	1.422	1.580	91	.128
	1,750,000	.00593	1.546	1.872	127	.117
	2,000,000	.00518	1.630	2.084	127	.125

NOTE: Nos. 14 to 8, solid; Nos. 6 and larger, stranded.  
No. 18, diam. .040; 1624 CM. No. 16, diam. .051; 2583 CM.

**Insulated Conductors.** The following table lists insulated wires or conductors according to the generally used trade names and type letters as given in the National Electrical Code. Maximum operating temperatures are those of surrounding air spaces. The kind and thickness of insulation, and the kind of outer covering determine the uses for which the various conductors are permitted. Note that the uses of many types of conductors are strictly limited, while others are designed for special purposes.

CONDUCTORS AND WIRES  
INSULATED CONDUCTORS

Trade Name	Type Letter	Maximum Operating Temperature	Insulation	Thickness of Insulation	Outer Covering	Use
Code	R	50C (122F)	Code Grade Rubber	14-10.....3/64 8-2.....4/64 1-4/0.....5/64 250-500.....6/64 501-1000.....7/64 Over 1000.....8/64	Moisture-Resistant Flame-Retardant Fibrous Covering	General Use
Moisture Resistant	RW	50C (122F)	Moisture Resistant Rubber	Same as Type R	Moisture-Resistant Flame-Retardant Fibrous Covering	General Use or in Wet Locations. See Note A
Performance	RP	60C (140F)	Performance Grade Rubber	Same as Type R	Moisture-Resistant Flame-Retardant Fibrous Covering	General Use
Heat-Resistant	RH	75C (167F)	Heat-Resistant Grade Rubber	Same as Type R	Moisture-Resistant Flame-Retardant Fibrous Covering	General Use
Small Diameter Building Wire (Heat-Resistant)	RHT	75C (167F)	Heat-Resistant Grade Rubber	14-10.....2/64 8.....3/64	Moisture-Resistant Flame-Retardant Fibrous Covering	General Use See Note B
Small Diameter Building Wire (Performance)	RPT	60C (140F)	Performance Grade Rubber	14-10.....2/64	Moisture-Resistant Flame-Retardant Fibrous Covering	Rewiring Existing Raceways See Note C
Type RU Wire (See Note)	RU	60C (140F)	90 Per Cent Unmilled Grainless Rubber	14-10.....18 Mils	Moisture-Resistant Flame-Retardant Fibrous Covering	Rewiring Existing Raceways See Note C
Solid Synthetic (See Note)	SN	60C (140F)	Solid Flame-Retardant Moisture-Resistant Synthetic Compound	14-10.....2/64 8.....3/64 6-2.....4/64 1-4/0.....5/64	None	Rewiring Existing Raceways See Note C



**CONDUCTORS AND WIRES  
INSULATED CONDUCTORS (Cont.)**

Trade Name	Type Letter	Maximum Operating Temperature	Insulation	Thickness of Insulation	Outer Covering	Use
Asbestos Synthetic	SNA	90C (194F)	Synthetic and Felted Asbestos	14-8..... Synthetic.....20 Mills Asbestos.....20 Mills	Flame-Retardant Cotton Braid	Switchboard Wiring
Varnished Cambric	V	85C (185F)	Varnished Cambric	Same as Type R Except 8.....3/64	Fibrous Covering or Lead Sheath	Dry Locations Only Unless Lead Sheathed. Smaller than No. 6 by Special permission.
Asbestos Varnished Cambric	AVA	110C (230F)	Impregnated Asbestos and Varnished Cambric	14-8 Sol.....45 Mills 6-2 Sol.....65 Mills 1-4/0 Sol.....75 Mills 14-2 Str.....60 Mills 1-4/0 Str.....80 Mills 250-1000 Str..110 Mills	Asbestos Braid	General Use Dry Locations
Asbestos Varnished Cambric	AVB	90C (194F)	Same as Type AVA	14-8 Sol.....50 Mills 6-4/0 Sol.....80 Mills 14-2 Str.....60 Mills 1-4/0 Str.....80 Mills 250-1000 Str..110 Mills	Flame-Retardant Cotton Braid	General Use Dry Locations
Asbestos Varnished Cambric	AVL	110C (230F)	Same as Type AVA	Solid or Stranded 14-2.....75 Mills 1-4/0.....80 Mills 250-1000.....110 Mills	Lead Sheath	General Use Wet Locations
Asbestos	A	200C (392F)	Felted Asbestos	14-8.....40 Mills 6-2.....60 Mills 1-4/0.....90 Mills 250-1000.....120 Mills	With or Without Asbestos Braid	Dry Locations Only. Not for General Conduit Installation. In Raceways, only as Leads to or within apparatus. If without Braid or Moisture-resistant Treatment, Limited to 300 Volts.
Impregnated Asbestos	AI	125C (257F)	Impregnated Felted Asbestos	Same as Type A	With or Without Impregnated Asbestos Braid	

**CONDUCTORS AND WIRES**  
**INSULATED CONDUCTORS (Cont.)**

Trade Name	Type Letter	Maximum Operating Temperature	Insulation	Thickness of Insulation	Outer Covering	Use
Paper		85C (185F)	Paper		Lead Sheath	See Note D
Slow Burning	SB	90C (194F)	3 Braids Impregnated Fire-Retardant Thread	Same as Type V	Outer Cover Finished Smooth and Hard	For Use Only in Dry Locations.
Slow Burning Weatherproof	SBW	90C (194F)	2 Layers Impregnated Cotton Thread	Same as Type V	Outer Fire-Retardant Coating	For Use Only in Dry Locations.
Weatherproof	WP	80C (176F)	At Least Three Cotton Braids or Equivalent Impregnated			May be used for Interior Wiring Only by Special Permission.

Synthetic insulation may stiffen at temperatures below freezing and care should be used in its installation at these temperatures.

**Note A.** Wet locations include underground, in concrete slabs or other masonry in direct contact with earth, or where condensation and accumulation of moisture within the raceway is likely to occur.

**Note B.** Sometimes used instead of types R, RP, or RH.

**Note C.** Used when, in rewiring for increased load, space is not available in raceways for type R conductors, and it is not practicable to increase the raceway size because of structural conditions.

**Note D.** Used for underground service conductors up to the point of attachment to service equipment, except that an uninsulated neutral may be permitted.

## CONDUCTORS AND WIRES

### CURRENT-CARRYING CAPACITIES OF CONDUCTORS

The two following tables give the maximum allowable current-carrying capacities, in amperes, of various types of conductors. These maximum currents are such as will prevent overheating of the conductor insulation and its surroundings. They do not take into consideration the voltage drop which, for runs of any great length, would be excessive were these maximum currents being carried.

One table shows currents for not more than three conductors enclosed together in a raceway or cable. This table applies to all wiring except that which is open, on insulators, and that for concealed knob and tube work. The other table shows currents for a single conductor in free air, and applies only to open conductors on insulators and to concealed knob and tube work.

Four to six conductors in a single cable or raceway require that the maximum current-carrying capacity be reduced to 80 per cent of that for not more than three conductors.

Seven to nine conductors in one cable or raceway require that the maximum current-carrying capacity be reduced to 70 per cent of that for not more than three conductors.

Bare conductors used with insulated conductors have a maximum current-carrying capacity limited to that permitted for the insulated conductor with which they are used.

Aluminum conductors have an allowable current-carrying capacity equal to 84 per cent of the capacities given for the same size copper wire with the same kind of insulation.

For room temperatures of 40° C. (104° F.) and higher, multiply the capacities in the table by the correction factor for the existing temperature or the one next higher. These fractional factors always reduce the capacity.

Allowable current-carrying capacity of No. 18 is 5 amperes; except that in rubber jacketed cords, types S, SO, SJ, SJO, and SV it is 7 amperes, and in heater cords types AFS, AFSJ, HC, HPD and HSJ it is 10 amperes. Allowable current-carrying capacity of No. 16 is 7 amperes; except that in above mentioned rubber jacketed cords it is 10 amperes, and in above heater cords it is 15 amperes. Allowable current-carrying capacity of No. 20 is 3 amperes.

These tables and instructions are from the National Electrical Code.

## CONDUCTORS AND WIRES

### ALLOWABLE CURRENT-CARRYING CAPACITIES OF CONDUCTORS IN AMPERES

Not More Than Three Conductors in Raceway  
or Cable

(Based on Room Temperature of 30° C. 86° F.)

Size AWG MCM	Rubber Type RW Type R	Synthetic Type SN	Rubber Type RHT Type RH	Paper	Asbestos Var-Cam Type AVA Type AVL	Impreg- nated Asbestos Type AI	Asbestos Type A
		Type RU		Synthetic Type SNA			
		Rubber Type RPT Type RP		Asbestos Var-Cam Type AVB			
				Var-Cam Type V			
14	15	18	22	23	28	29	32
12	20	23	27	29	36	38	42
10	25	31	37	38	47	49	54
8	35	41	49	50	60	63	71
6	50	54	65	68	80	85	95
5	55	63	75	78	94	99	110
4	70	72	86	88	107	114	122
3	80	83	99	104	121	131	145
2	90	96	115	118	137	147	163
1	100	110	131	138	161	172	188
0	125	127	151	157	190	202	223
00	150	145	173	184	217	230	249
000	175	166	199	210	243	265	284
0000	225	193	230	270	275	308	340
250	250	213	255	300	315	334	372
300	275	238	285	330	347	380	415
350	300	260	311	360	392	419	462
400	325	281	336	390	418	450	488
500	400	319	382	480	480	498	554
600	450	353	422	540	540	543	612
700	500	385	461	600	600	598	668
750	525	398	475	630	630	621	690
800	550	410	490	660	660	641	720
900	600	434	519	720	720	...	...
1,000	650	455	543	780	780	730	811
1,250		493	589	900	900	...	...
1,500	850	522	625	1020	1020	...	...
1,750		544	650	1140	1140	...	...
2,000	1050	558	666	1260	1260	...	...
1,100	690						
1,200	730						
1,300	770						
1,400	810						
1,600	890						
1,700	930						
1,800	970						
1,900	1010						

#### CORRECTION FACTOR FOR ROOM TEMPERATURES OVER 30°C.

C. F.	.71	.82	.88	.90	.94	.95	...
40 104							
45 113	.60	.71	.82	...	...	...	...
50 122	.00	.58	.75	.80	.87	.89	...
55 131	...	.41	.67	...	...	...	...
60 140	...	.00	.58	.67	.79	.83	.97
70 158	...	...	.35	.52	.71	.76	.93
75 167	...	...	.00	...	...	...	...
80 176	...	...	...	.30	.61	.69	.89
90 194	...	...	...	...	.50	.61	.86
100 212	...	...	...	...	...	.51	.82
120 248	...	...	...	...	...	...	.72
140 284	...	...	...	...	...	...	.63

Emergency insulation Type EI has same current-carrying capacity as Synthetic Type SN, in third column of table.

# CONDUCTORS AND WIRES

## ALLOWABLE CURRENT-CARRYING CAPACITIES OF CONDUCTORS IN AMPERES

**Single Conductor in Free Air**  
(Based on Room Temperature of 30° C. 86° F.)

Size AWG or MCM	Rubber Type R	Rubber Type RP	Rubber Type RHT Type RH	Syn- thetic Type SNA	As- bestos Var- Cam Type AVA	Impreg- nated As- bestos Type AI	As- bestos Type A	Slow- burning Type SB	
				As- bestos Var- Cam Type AVB					Weather- proof Type W Type SBW
				Var- Cam Type V					
14	20	24	29	30	39	40	43	30	
12	26	31	37	40	51	52	57	39	
10	35	42	50	54	65	69	75	54	
8	48	58	69	71	85	91	100	71	
6	65	78	94	99	119	126	134	98	
5	76	92	110	115	136	145	158	130	
4	87	105	125	133	158	169	180	152	
3	101	122	146	155	182	194	211	176	
2	118	142	170	179	211	226	241	203	
1	136	164	196	211	247	264	280	237	
0	160	193	230	245	287	306	325	274	
00	185	223	267	284	331	354	372	318	
000	215	259	310	330	384	410	429	368	
0000	248	298	358	383	446	476	510	410	
250	280	338	403	427	495	528	562	460	
300	310	373	446	480	555	592	632	508	
350	350	421	504	529	612	653	698	554	
400	380	457	547	575	665	710	755	620	
500	430	517	620	660	765	814	870	709	
600	480	577	691	738	857	912	970	779	
700	525	632	756	813	942	1003	1065	811	
750	545	655	785	846	981	1044	1118	845	
800	565	680	815	879	1020	1085	1150	920	
900	605	728	872	941	....	....	....	1000	
1,000	650	782	936	1001	1163	1238	1332	1360	
1,250	740	890	1066	1131	....	....	....	1670	
1,500	815	980	1174	1261	1452	....	....	....	
1,750	890	1070	1282	1370	....	....	....	....	
2,000	980	1155	1383	1472	....	....	....	....	

### CORRECTION FACTOR FOR ROOM TEMPERATURES OVER 30° C.

C. F.	.71	.82	.88	.90	.94	.95	...	...
40 104	.71	.82	.88	.90	.94	.95	...	...
45 113	.50	.71	.82	...	...	...	...	...
50 122	.00	.58	.75	.80	.87	.89	...	...
55 131	...	.41	.67	...	...	...	...	...
60 140	...	.00	.58	.67	.79	.83	.97	...
70 158	...	...	.35	.52	.71	.76	.93	...
75 167	...	...	.00	...	...	...	...	...
80 176	...	...	...	.30	.61	.69	.89	...
90 194	...	...	...	...	.50	.61	.86	...
100 212	...	...	...	...	...	.61	.82	...
120 248	...	...	...	...	...	...	.72	...
140 284	...	...	...	...	...	...	.63	...

Emergency insulation Type EI has same current-carrying capacity as Rubber Type RP, in third column of table.

## CONDUCTORS AND WIRES

Number of Small Wires Required for Same Current-Carrying Capacity as One Larger Wire		NUMBER OF SMALLER WIRES									
SINGLE WIRE	Circ Mills	14 Ga.	12 Ga.	10 Ga.	8 Ga.	6 Ga.	5 Ga.	4 Ga.	3 Ga.	2 Ga.	1 Ga.
1,000,000			96	60	38	30	24	18	15	12	
900,000			86	54	34	27	21	16	13	10	
800,000			77	48	30	24	19	14	12	9	
750,000			72	45	28	22	18	14	11	8	
700,000			67	42	26	21	16	13	10	8	
600,000		91	57	36	22	18	14	11	9	7	
500,000			48	30	19	15	12	9	7	6	
400,000			38	24	15	12	9	7	6	4	
350,000		97	33	21	13	10	8	6	5	4	
300,000			28	18	11	9	7	5	4	3	
250,000			24	15	9	7	6	4	3	2	
Gauge No.											
0000		51	32	20	12	8	6	4	3	2	
000		40	25	16	10	6	5	4	3	2	
00		32	20	12	8	5	4	3	2	2	
0		25	16	10	6	4	3	2	2	2	
1		20	12	8	5	3	2	2	2	2	
2		16	10	6	4	2	2	2	2	2	
3		12	8	5	3	2	2	2	2	2	
4		10	6	4	2	2	2	2	2	2	
5		8	5	3	2	2	2	2	2	2	
6		6	4	2	2	2	2	2	2	2	
8		4	2	2	2	2	2	2	2	2	
10		2	2	2	2	2	2	2	2	2	

Example: The carrying capacity of one No. 00 wire is equal to that of 32 No. 14 wires, 20 No. 12 wires, 12 No. 10 wires, etc.

**SIZES OF INSULATED WIRE.** Following tables give outside diameters and cross sectional areas of various types of insulated wires. This information is used in computing required sizes of conduit or tubing, and of openings through insulators, for one or more conductors. Conductor diameters and sizes given in the copper wire tables are for the metallic conductor only, and bear no definite relation to the sizes of the wires when covered with various kinds of insulation.

## CONDUCTORS AND WIRES DIMENSIONS OF CONDUCTORS

### Types R, RW, RP, and RH

Size AWG-CM	Approx. Diam. Inches	Approx. Area Sq. Ins.	Size CM	Approx. Diam. Inches	Approx. Area Sq. Ins.
18	.14	.0154	450,000	1.08	.91
16	.15	.018	500,000	1.12	.99
14	.20	.031	550,000	1.17	1.08
12	.22	.038	600,000	1.22	1.16
10	.24	.045			
8	.30	.071	650,000	1.25	1.23
			700,000	1.29	1.30
6	.41	.13	750,000	1.33	1.38
4	.45	.16	800,000	1.36	1.45
2	.52	.21			
1	.59	.27	850,000	1.39	1.52
			900,000	1.43	1.60
0	.63	.31	950,000	1.46	1.68
00	.67	.35	1,000,000	1.49	1.75
000	.72	.41			
0000	.78	.48	1,250,000	1.68	2.22
250,000	.86	.58	1,500,000	1.79	2.52
300,000	.92	.67	1,750,000	1.90	2.85
350,000	.98	.75	2,000,000	2.00	3.14
400,000	1.03	.83			

No. 18 to No. 8, solid conductor, No. 6 and larger, stranded.

### Small Diameter Building Wires, Types RHT and RPT

Size AWG	Approx. Diam. Inches	Approx. Area Sq. Ins.	Size AWG	Approx. Diam. Inches	Approx. Area Sq. Ins.
14	.162	.0206	10	.200	.0314
12	.179	.0252	8	.261	.0535

Note—Small diameter building wire, Type RPT, recognized in sizes Nos. 14, 12 and 10. No. 14 to No. 8, solid conductors.

### Synthetic Insulation, Type SN Type RU Insulation

Size AWG	Approx. Diam. Inches	Approx. Area Sq. Ins.	Size AWG	Approx. Diam. Inches	Approx. Area Sq. Ins.
14	.130	.0133	2	.423	.1405
12	.147	.0170	1	.496	.1935
10	.168	.0220	0	.537	.226
8	.227	.0405	00	.583	.267
6	.314	.0775	000	.634	.316
4	.363	.1035	0000	.692	.376

NOTE: Type SN conductors recognized in sizes Nos. 14 to No. 0000; Type RU conductors recognized in sizes No. 14 to No. 10. No. 14 to No. 8, solid conductors, No. 6 and larger, stranded. Type SN conductors without an outer covering and Type RU conductors with an outer covering have the same overall diameters.

**CONDUCTORS AND WIRES**  
**DIMENSIONS OF CONDUCTORS**  
Lead Covered—Types RL, RPL and RHL

Size of Conductor AWG-CM	Single Conductor		Two Conductor		Three Conductor	
	Diam. Inches	Area Sq. Ins.	Diam. Inches	Area Sq. Ins.	Diam. Inches	Area Sq. Ins.
14	.28	.062	.28 x .47	.115	.59	.273
12	.29	.066	.31 x .54	.146	.62	.301
10	.35	.096	.35 x .59	.180	.68	.363
8	.41	.132	.41 x .71	.255	.82	.528
6	.49	.188	.49 x .86	.369	.97	.738
4	.55	.237	.54 x .96	.457	1.08	.916
2	.60	.283	.61 x 1.08	.578	1.21	1.146
1	.67	.352	.70 x 1.23	.756	1.38	1.49
0	.71	.396	.74 x 1.32	.859	1.47	1.70
00	.76	.454	.79 x 1.41	.980	1.57	1.94
000	.81	.515	.84 x 1.52	1.123	1.69	2.24
0000	.87	.593	.90 x 1.64	1.302	1.85	2.68
250	.98	.754	.....	.....	2.02	3.20
300	1.04	.85	.....	.....	2.15	3.62
350	1.10	.95	.....	.....	2.26	4.02
400	1.14	1.02	.....	.....	2.40	4.52
500	1.23	1.18	.....	.....	2.59	5.28

Note—No. 14 to No. 8, solid conductors; No. 6 and larger, stranded conductors.

**VARNISHED-CAMBRIC CONDUCTORS**  
Types AVA, AVB, and AVL

Size AWG C.M.	Type AVA		Type AVB		Type AVL	
	Approx. Diam. Inches	Approx. Area Sq. In.	Approx. Diam. Inches	Approx. Area Sq. In.	Approx. Diam. Inches	Approx. Area Sq. In.
14	.245	.047	.205	.033	.320	.080
12	.265	.055	.225	.040	.340	.091
10	.285	.064	.245	.047	.360	.102
8	.310	.075	.270	.057	.390	.119
6	.395	.122	.345	.094	.430	.145
4	.445	.155	.395	.123	.480	.181
2	.505	.200	.460	.166	.570	.255
1	.585	.268	.540	.229	.620	.300
0	.625	.307	.580	.264	.660	.341
00	.670	.353	.625	.307	.705	.390
000	.720	.406	.675	.358	.755	.447
0000	.780	.478	.735	.425	.815	.521
250,000	.885	.616	.855	.572	.955	.715
300,000	.940	.692	.910	.649	1.010	.800
350,000	.995	.778	.965	.731	1.060	.885
400,000	1.040	.850	1.010	.800	1.105	.960
450,000	1.085	.925	1.055	.872	1.150	1.040
500,000	1.125	.995	1.095	.945	1.190	1.118
550,000	1.165	1.065	1.135	1.01	1.265	1.26
600,000	1.205	1.140	1.175	1.09	1.305	1.34
650,000	1.240	1.21	1.210	1.15	1.340	1.41
700,000	1.275	1.28	1.245	1.22	1.375	1.49
750,000	1.310	1.35	1.280	1.29	1.410	1.57
800,000	1.345	1.42	1.315	1.36	1.440	1.63
850,000	1.375	1.49	1.345	1.43	1.470	1.70
900,000	1.405	1.55	1.375	1.49	1.505	1.78
950,000	1.435	1.62	1.405	1.55	1.535	1.85
1,000,000	1.465	1.69	1.435	1.62	1.565	1.93

Note: No. 14 to No. 8, solid, No. 6 and larger, stranded; except AVL where all sizes are stranded.



# CONDUCTORS AND WIRES

## MAGNET WIRE Turns per Inch of Winding Length

Gauge Size of Wire	Enamel Covered	Cotton Covered			Silk Covered		
		Double D. C. C.	Single S. C. C.	Enamel S. C. E.	Double D. S. C.	Single S. S. C.	Enamel S. S. E.
10	9.6	8.9	9.3	9.1	8.5	9.2	9.4
11	10.8	9.9	10.4	10.2	9.5	10.3	10.6
12	12.1	11.0	11.6	11.3	10.6	11.5	11.8
13	13.5	12.1	12.9	12.7	11.9	12.9	13.2
14	15.2	12.9	14.3	14.1	13.3	14.3	14.7
15	17.0	14.4	16.1	15.8	15.0	16.1	16.5
16	19.2	16.4	17.2	17.6	16.8	18.0	18.2
17	21.3	18.1	18.8	19.4	18.5	20.2	20.5
18	23.8	20.0	21.0	21.5	20.8	22.5	22.9
19	27.0	21.8	23.6	24.0	23.2	25.5	26.0
20	30.0	24.0	26.4	27.0	25.5	28.0	28.6
21	34.2	26.2	29.7	29.5	28.7	31.3	31.8
22	38.4	28.6	32.1	32.5	31.0	34.8	35.2
23	41.8	31.2	36.4	36.1	34.3	38.2	38.7
24	47.7	33.6	39.0	39.5	38.0	43.0	43.5
25	52.6	36.2	43.1	43.3	41.5	47.7	48.1
26	59.0	40.0	47.0	47.5	45.8	52.4	53.0
27	66.6	42.6	51.2	52.0	50.0	58.0	58.8
28	77.0	45.5	56.5	57.5	53.5	64.7	65.0
29	83.3	48.0	61.4	62.3	58.5	71.3	71.4
30	91.0	51.0	67.6	67.2	66.5	80.2	80.5
31	100.0	56.8	72.3	72.5	71.7	87.9	88.0
32	116.5	60.0	79.0	79.0	76.2	95.0	94.3
33	129.8	64.4	85.0	85.4	83.0	105.1	106.0
34	142.8	68.6	91.8	91.7	88.7	110.0	110.0
35	160.6	73.0	98.6	97.8	104.3	130.9	129.0
36	178.6	78.6	106.0	103.5	110.4	140.0	136.0
37	200.0	84.0	114.0	111.0	115.0	150.0	143.0
38	222.0	89.0	123.0	118.0	120.0	160.5	154.0
39	245.0	95.0	131.0	130.0	131.0	182.0	175.0
40	270.0	102.0	139.0	139.0	140.0	200.0	195.0

The above numbers of turns per inch of winding length for various types of magnet wire are only approximate, since the exact diameters of such wires will vary between different manufacturers.

The approximate number of turns per square inch of a solid layer winding is equal to the square of the number of turns per inch of length given above. That is, the number of turns per inch is multiplied by itself. Example: In a solid layer winding of No. 22 single cotton enamel wire (SCE) there are 32.5 turns per running inch, and  $32.5 \times 32.5$ , or 1,056 turns per square inch of winding cross section.

CONDUCTOR AND RESISTOR MATERIALS					
MATERIAL	SPECIFIC RESISTANCE		TEMPERATURE COEFFICIENT OF RES. Per Degree Fahrenheit	MELTING POINT Degrees Fahr.	WEIGHT Lbs. per Cubic Inch
	Ohms per Circular mil-foot at 68° F.	Square Root			
Aluminum	17.3	4.16	0.0019	1220	0.095
Brass	42.1	6.49	.0011	1680	.310
Constantan	295	17.18	.00001	2355	.349
Copper					
annealed	10.4	3.22	.00218	1980	.320
hard drawn	10.65	3.26	.00212	1980	.320
Iron, pure	61.1	7.82	.0034	2865	.260
Lead	114.7	10.69	.0023	620	.410
Lucerno	256	16.00	.0011	2480	.320
Manganin	270	16.43	.00001		.294
Monel	256	16.00	.0011	2460	.337
Nichrome IV	625	25.00	.00006	2535	.306
Nickel					
pure	60	7.75	.0023	2650	.320
Platinum	72	8.49	.0021	3170	.765
Silver	9.75	3.12	.0021	1760	.381
Steel					
galvanized	66.7	8.17	.0023	2460	.280
Tungsten	342	18.49	.0026	5450	.092
Zinc	38	6.16	.0021	785	.260

## CONDUCTORS AND WIRES

**RESISTANCE OF A CONDUCTOR** at any temperature may be found, approximately, when its resistance is known for one temperature.

When  $R$  = resistance in ohms at one temperature, as taken from a wire table.

$X$  = resistance in ohms to be determined.

$D$  = difference between temperature given in table and desired temperature, degrees.

$K$  = temperature coefficient of resistance for material of which the conductor is made.

$$X = R \times (1 + D \times K)$$

Note: Multiply  $D$  and  $K$  together, add 1 to the product, and multiply this sum by  $R$ . Temperature coefficients of resistance are listed in an accompanying table.

Example: The resistance of 1,000 feet of No. 14 wire at  $68^\circ$  is shown by the copper wire table to be 2.504 ohms. What is the resistance at  $95^\circ$ ? Substituting values in the formula gives.

$$X = 2.504 \times (1 + 27^\circ \times .00218)$$

$$27^\circ \times .00218 + .059 = 1.059$$

$$2.504 \text{ ohms} \times 1.059 = 2.652 \text{ ohms at } 95^\circ.$$

**RESISTANCE OF A CONDUCTOR** of any material and of any cross sectional area in circular mils may be calculated as follows:

$$\text{Resistance in ohms} = \frac{\text{total feet of conductor} \times \text{ohms per circ. mil-foot}}{\text{cross section, circular mils}}$$

Resistances in ohms per circular mil-foot are given in the table of Conductor and Resistor Materials.

Areas in circular mils for various gauge numbers are given in the copper wire tables.

The area in circular mils of any round conductor is equal to the square of the diameter in inches, multiplied by 1,000,000.

Example: What is the resistance of 50 feet of No. 30 manganin wire? From the table of conductor and Resistor Materials we find that the specific resistance is 270 ohms per circular mil-foot. From the copper wire table the area of No. 30 wire is 100.5 circular mils. Substituting these values in the formula gives,

$$\text{Resistance in ohms} = \frac{50 \times 270}{100.5} = 134.3 \text{ ohms}$$

This is the resistance at  $68^\circ$  F. For the resistance at any other temperature we would use the formula that includes the temperature coefficient of resistance.

## CONDUCTORS AND WIRES

**VOLTAGE DROP** or loss of voltage in a conductor usually is limited to a certain number of volts or else to a certain percentage of the supply voltage. The drop in lighting circuits often is required to be no more than 2%, and in motor or other power circuits no more than 5% of the supply voltage.

The following formulas are used when solving problems involving voltage drops.

$$\text{Drop in volts} = \frac{10.4 \times \text{amperes} \times \text{total feet of wire}}{\text{circular mils, of wire used}}$$

Example: How many volts will be lost in a 2-wire line of No. 14 copper wire 180 feet long when carrying 15 amperes?

A 2-wire line 180 feet long has  $2 \times 180$ , or 360 feet of wire. No. 14 has an area of 4,107 circular mils. Placing these values in the formula gives,

$$\text{Drop in volts} = \frac{10.4 \times 15 \times 360}{4107} = 13.7 \text{ volts}$$

The per cent of supply line voltage lost in wiring is found as follows:

$$\text{Per cent drop} = \frac{\text{ohms per 1,000 ft.} \times \text{amperes} \times \text{ft. wire}}{9.8 \times \text{supply voltage}}$$

Example: Again consider the 2-wire line 180 feet long (360 feet of wire) of No. 14 copper wire carrying 15 amperes, and assume a 220-volt supply. What is the per cent voltage drop, based on the supply voltage? The copper wire table gives the resistance as 2.504 ohms per 1,000 feet. Placing the values in the formula gives,

$$\text{Per cent drop} = \frac{2.504 \times 15 \times 360}{9.8 \times 220} = 6.21\% \text{ drop.}$$

The required size of conductor, in circular mils, for a given number of volts drop is found as follows:

$$\text{Conductor circ. mils} = \frac{10.4 \times \text{amperes} \times \text{total feet of wire}}{\text{number of volts drop}}$$

Example: What size conductor must be used in a 2-wire line 85 feet long carrying 18 amperes if the drop is not to exceed 6 volts? Placing these values in the formula gives,

$$\text{Conductor circ. mils} = \frac{10.4 \times 18 \times (2 \times 85)}{6} = 5304$$

The smallest conductor having at least 5304 circular mils area, or greater, is No. 12.

## CONDUCTORS AND WIRES

The total feet of conductor in which the voltage drop will not exceed a certain percentage of the supply voltage is found as follows:

$$\text{Wire feet} = \frac{9.9 \times \text{per cent drop} \times \text{supply voltage}}{\text{amperes} \times \text{ohms per 1,000 feet}}$$

Example: How many feet of wire may be used in a circuit carrying 24 amperes with number 10 wire from a 220-volt supply when the voltage drop is not to exceed 5% of the supply voltage?

From the copper wire table we find that No. 10 wire has a resistance of 0.8441 ohm per 1,000 feet. Using the values in the formula gives,

$$\text{Wire feet} = \frac{9.9 \times 5 \times 220}{24 \times 0.844} = 538 \text{ feet}$$

A 2-wire circuit might have a length of one-half 538, or 269 feet.

The total feet of conductor in which the drop will not exceed a certain number of volts is found thus:

$$\text{Wire feet} = \frac{\text{volts drop} \times \text{circ. mils of conductor}}{10.4 \times \text{amperes}}$$

Example: How many feet of wire may be used in a circuit carrying 24 amperes with No. 10 wire when the drop is not to exceed 6 volts?

From the copper wire table we find that No. 10 wire has an area of 10382 circular mils. Placing the values in the formula gives,

$$\text{Wire feet} = \frac{6 \times 10382}{10.4 \times 24} = 250 \text{ feet}$$

A 2-wire circuit might have a length of one-half 247 feet, or about 123 feet maximum.

**FOR THE SAME VOLTAGE DROP** the current-carrying capacities of two wires of equal diameters but of different materials are inversely as the square roots of their specific resistances at the same temperature. These square roots are given in the table of Conductor and Resistor Materials.

1. Divide the square root of the specific resistance for conductor A by the square root of the specific resistance for conductor B.

2. Multiply the result by the current-carrying capacity of conductor A.

3. The product is the current-carrying capacity of conductor B.

Example: A No. 12 gauge copper wire is carrying 20 amperes. How many amperes may be carried by a galvanized steel wire of the same diameter if the voltage drop is not to increase?

## CONDUCTORS AND WIRES

The table lists the square roots of the specific resistances as 3.22 for copper and 8.17 for galvanized steel.

1.  $3.22 \div 8.17 = 0.394$
2.  $0.394 \times 20 = 7.88$  amperes

**Flexible Cords.** The following numbered notes are referred to by numbers in the "Type" column of the tables which give descriptions of flexible cords. These tables are from the National Electrical Code.

1. Except for types AFPO, AVPO, CFPO, PO-64, PO-32, PO, POSJ-64 and POSJ-32 individual conductors are twisted together.

2. Type PO-64 is for use only with portable lamps, portable radio receiving appliances, portable clocks and similar appliances which are not liable to be moved frequently and where appearance is a consideration.

3. Types AT, CT, ATJ and CTJ are suitable for use in lengths not exceeding eight feet when attached directly, or by means of a special type of plug, to a portable appliance rated at 50 watts or less and of such a nature that extreme flexibility of the cord is essential. Types AT and ATJ are for use only with heating appliances.

4. Type K is suitable for use on theatre stages.

5. Rubber-filled or varnished cambric tapes may be substituted for the inner braids.

6. Type S is suitable for use on theatre stages, in garages and elsewhere, where flexible cords having rubber insulation are permitted by this code.

7. Type E may have a composite assembly of steel and copper strands in the make-up of the conductors.

Use		Trade Name	Type	Braid on Each Conductor	Filler	Outer Covering			
						Kind	Number		
Attached to a Device	Dry Places	Not Subject to Hard Usage	Asbestos Covered Tinsel Cord	AT	3	Cotton	None	None	
			Cotton Covered Tinsel Cord	CT	3	None	None	Cotton or Rayon	1
Damp Places	Rubber Jacketed Tinsel Cord		ATJ	3	None	None	None	Rubber	1
			CTJ	3	Cotton	None	Cotton or Rayon	1 or None	
Pendant	Dry Places		Asbestos Covered Heat-Resistant Cord	AFC		Cotton or Rayon	None	None	None
				AFPO		None	None	Cotton, Rayon or Saturated Asbestos	1
			AFPD		Cotton or Rayon	None	None	None	
		Cotton Covered Heat Resistant Cord	CFC		None	None	Cotton or Rayon	1	
See Note 2	Damp Places	Lamp Cord		CFPD		None	None	None	
				PO-64		Cotton	None	Cotton or Rayon	1
Pendant or Portable	Dry Places	Hard Usage	Parallel Cord	PO-32		None	None	None	
				PO		None	None	Rubber	1
			All Rubber Parallel Cord	POSJ-64		None	None	None	None
				POSJ-32		Cotton	None	Metal Armor	1
			Armored Cord	CA		None	None	Cotton or Rayon	1
		Not Subject to Hard Usage	Twisted Portable Cord	PD		None	None	1	
			Reinforced Cord	P-64		Cotton	Rubber	Cotton	1
				P-32					
				P					

CONDUCTORS AND WIRES  
 FLEXIBLE CORDS

**CONDUCTORS AND WIRES**

**FLEXIBLE CORDS (Continued)**

Pendant or Portable	Damp Places	Not Subject to Hard Usage	Moisture-Proof Reinforced Cord	PWP64 PWP32 PWP	Cotton	Rubber	Cotton Moisture Resistant Finish	1
			Braided Heavy Duty Cord	K <sup>4</sup>	Cotton	Jute, Cotton, Sisal, Hemp, Twisted Paper	Cotton-Moisture-Resistant Finish	2 <sup>6</sup>
			Vacuum Cleaner Cord	SV	None	None	Rubber	1
			Jun'r Hard Service Cord	SJ SJO			Oil-Res't Compound	
Portable	Dry Places	Portable Heaters	Hard Service Cord	S <sup>6</sup> SO	None	None	Rubber	None
			Rubber Jacketed Heat-Resistant Cord	AFS AFSJ			Oil-Res't Compound	
			Heater Cord	HC			Rubber	1
			Rubber Jacketed Heater Cord	HPD			None	None
Pendant or Portable	Damp Places	Not Subject to Hard Usage	Heat and Moisture Resistant Cord	AVPD AVPO	None	None	Cotton and Rubber	1
							Saturated Asbestos	1
Elevator Lighting and Control			Elevator Cable	E <sup>7</sup>	Cotton	Rubber	Cotton-Flame Retardant Moisture-Resistant Finish	1
						None	Cotton-Outer One Flame-Retardant Moisture Resistant	3 <sup>6</sup>



## Section 4

### RESISTORS AND RESISTANCE

**Resistance.** The property of a substance which opposes flow of electricity through the substance. Flow of current against the opposition of resistance causes heating of the substance. Resistance increases direct with the length and inversely with the cross sectional area of a conductor. Resistance increases at a non-uniform rate with rise of temperature in all pure metals and in most alloys, but decreases in most liquids and in carbon. Resistance is measured in ohms.

**Conductance.** A measure of the ease with which a substance conducts electricity. Conductance is measured in ohms. Conductance in ohms is equal to the reciprocal of the resistance in ohms, or to the number 1 divided by the number of ohms.

**Ohm.** The unit of electrical resistance. With a potential difference of one volt across a resistance of one ohm the current through the resistance is one ampere. One ohm is the resistance of 396 feet of number 14 copper wire at a temperature of 68° F.

**Megohm.** One million ohms of resistance.

**Microhm.** One one-millionth of an ohm of resistance.

**Resistor.** A part which offers resistance to the flow of electric current. Its electrical size is specified in ohms or megohms. A resistor also has a power-handling rating in watts, indicating the amount of power which can safely be dissipated as heat by the resistor.

**Wire-wound Resistor.** A resistor which is constructed by winding a high-resistance wire on an insulating form. The resulting element may or may not be covered with a ceramic insulating layer.

**Carbon Resistor.** A resistor made of carbon particles and a ceramic binder molded into a cylindrical shape, with leads attached to opposite ends.

**Fixed Resistor.** A resistor having a definite ohmic value which cannot be adjusted.

**Variable Resistor.** A resistor which can be changed in value while in use.

**Rheostat.** A resistance unit which can be varied in ohmic value so as to control the flow of current in the circuit of which it is a part.

**Potentiometer.** A resistance unit having a rotating contact arm which can be set at any desired point on the resistance element. The total available voltage is applied to the fixed end terminals of the resistance element, and the output circuit is connected between the movable contact and one end terminal. Rotating

## RESISTORS AND RESISTANCE

the movable contact thus varies the proportion of the total voltage which is transferred to the output circuit.

**Voltage Divider.** A resistor, at an intermediate point or points on which are taps that permit taking certain fractions of the overall voltage from between the taps or between the taps and the ends of the resistor. Instead of fixed taps there may be one or more movable contacts that slide on the resistor or are connected to it through switches.

**Current Control.** In electrical work the need is constantly arising for adjusting a current to a specified value. This is usually done by varying the resistance of the circuit. Changes in the resistance of a circuit can be made by means of resistors, which consist in general of single resistance units, or groups of such units, made of suitable material. These may be variable or fixed in value. Variable resistors are frequently called "resistance boxes" or "rheostats," depending on their current-carrying capacity and range.

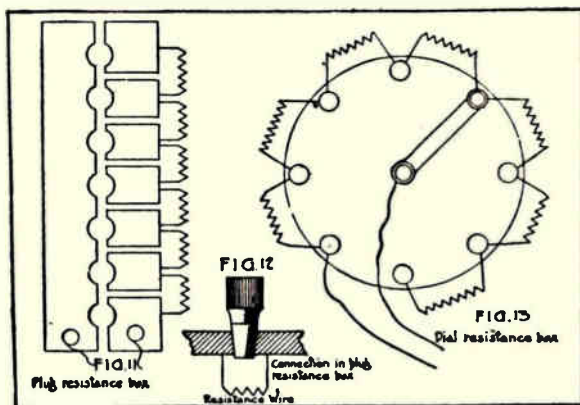


Fig. 4-1

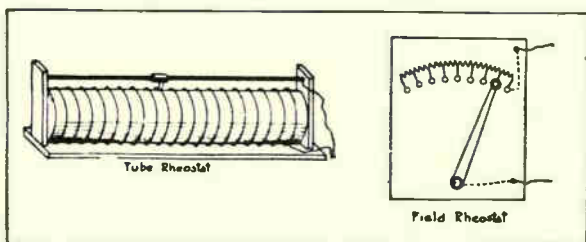
A resistance box consists of a group of coils of wire assembled compactly in a frame or box. It is so arranged that single coils or any desired combination of such coils may be introduced into the circuit by manipulating the switches or plugs. The extreme range of such a device may be from a hundredth or a tenth of an ohm up to 100,000 ohms. Each of its component units is accurately standardized and marked with its resistance value. By this means it is possible to know precisely what resistance is introduced into the circuit by the resistance box. The coils are wound with relatively fine wire, and in such a way that they do not

## RESISTORS AND RESISTANCE

have any appreciable magnetic fields about them. They are intended solely for carrying feeble currents, usually no more than a fraction of an ampere.

Resistors of single fixed values are convenient for many purposes. If they are carefully made and precisely measured, they are called standard resistance coils. Such standards may be secured in range from 0.00001 ohm to 100,000 ohms and of any desired current-carrying capacity and degree of precision. Resistance boxes and precision resistors are designed primarily for use in the laboratory.

The name "rheostat" is, in general, applied to a variable resistor having a fairly large current-carrying



capacity. A simple form of rheostat consists of a layer of German silver or nickel-steel wire wound on an insulating tube with a sliding contact traveling along the tube so that the current may be made to pass through any desired length of the wire. Such rheostats are not usually made to handle large amounts of power. Larger rheostats are made of resistance units connected between the points of a switch, as shown in Fig. 4-2. The units are made of resistance wire embedded in vitreous enamel on a metal plate or wound on a porcelain tube and then enameled. For very large units the resistors are made in the form of grids of cast iron, nickel steel, or similar metal, which are exposed to the air for cooling. The grid type of resistor is by far the most common in commercial use, especially for railway and electric-crane control. For extremely large currents a convenient compact rheostat is made by immersing metal plates to a variable depth in a conducting liquid; such a liquid rheostat can be easily cooled by using a metal container, or by changing the liquid as it becomes heated.

Banks of incandescent electric lamps in various arrangements are often used as resistors. The resistance of such lamps is subject to large variations in value with changes in temperature. However, when operating under steady conditions, either hot or cold,

## RESISTORS AND RESISTANCE

they are satisfactory for many purposes. Such a rheostat offers the advantage of being readily adjustable by turning lamps off or on. It is compact and there is no danger of overheating.

Another type of rheostat for handling large currents consists of a pile of carbon blocks or plates which are compressed by a screw or lever to reduce their electrical resistance.

### RESISTANCE OF RESISTOR ALLOYS AND MATERIALS

The resistance of conductors whose dimensions are known is easily calculated from either of two basic values which are obtainable from tables of resistivities.

1. Resistance in ohms per circular mil-foot.

One circular mil is the area of a circle  $1/1000$  inch in diameter. One circular mil-foot has an area of one circular mil and a length of one foot.

To find the area in circular mils of a round conductor multiply its diameter in inches by 1,000, then square the result. For example; a number 10 copper wire has a diameter of 0.1019 inch. Multiplying this diameter by 1,000 gives 101.9. Squaring 101.9 ( $101.9 \times 101.9$ ) gives 10,384, which is the area in circular mils. If the diameter is given in mils, simply square the number of mils to find the area in circular mils.

To find the area in circular mils of a conductor which is not round, first find its area in square inches. Then multiply the number of square inches by 1,273,200. For example, a conductor with a section of  $\frac{1}{4}$  by  $\frac{1}{2}$  inch has an area of  $\frac{1}{8}$  square inch. Then  $\frac{1}{8}$  times 1,273,200 = 159,150 circular mils.

2. Resistance in ohms per cubic centimeter.

Multiply ohms per cubic centimeter by 6,015,300 to find the equivalent ohms per circular mil-foot. If the resistivity is given in microhms per cubic centimeter, multiply by 6,0153 to find the equivalent ohms per circular mil-foot.

Resistance in ohms of any conductor is equal to,

$$\frac{\text{length of conductor in feet} \times \text{resistance of conductor in ohms per circular mil-foot}}{\text{area in circular mils}}$$

### RESISTANCE CHANGE DUE TO TEMPERATURE CHANGE

The accompanying table, "Resistor Alloys and Materials", lists resistances in ohms per circular mil-foot for most of the commonly used materials, and lists also temperature coefficients of resistance per degree Fahrenheit.

## RESISTORS AND RESISTANCE

In the section on Conductors and Wires are given instructions for using these temperature coefficients in determining the resistance of a conductor at any temperature when its resistance is known for some one temperature, such as at 68° F. as given in the table.

### RESISTOR ALLOYS AND MATERIALS

MATERIAL OR TRADE NAME	Ohms per Circ. Mil-ft. at 68° F. or 20° C.	Temperature Coefficient of Resistance, Degree F.
Advance	292	0.00001
aluminum	17.02	.0022
brass, common	49	.001
high brass	41	
low brass	35	
Calido	660	.00013
carbon	21000	— .0028
Chromel	540	
Climax	525	.0005
Comet	575	.0006
Constantan	294	.000005
copper, annealed	10.4	.000218
USS	10.55	.002
Eureka	294	.00002
German silver, 18%	198	.00018
graphite	4800	
Ideal	295	.000005
iron, pure	60	.0031
cast	540	
wrought	84	
Karma	625	.00005
Lucerno	275	.001
Manganin	345	.00001
Monel	253	.001
nickel	52	.0027
nickel silver, 30%	240	.0001
Nichrome II	660	.00013
III	540	.0001
IV	625	.00006
Novar	296	
phosphor bronze	47	.0013
Rayo	540	.0001
steel, galvanized	67	.0017
crucible	115	
hard	162	.001
manganese	420	.0005
Superior	517	
Therlo	283	.000005
tungsten	33.2	.0025

## RESISTORS AND RESISTANCE

**Resistance Changes Due to Current Flow.** Current flow through any conductor produces heat in that conductor, and ordinarily produces a rise of temperature. Thus, since current flow raises the temperature, and a rise of temperature increases resistance, we may say that current flow increases the resistance of a conductor in which the flow takes place.

As an example of heating due to current flow assume that we have a soft steel wire 1/100 inch in diameter and of such length that its resistance is 400 ohms. If a current flow of one ampere is maintained in this wire, and if all the heat produced is kept within the wire, the temperature of the wire will go up at the rate of 20 degrees every minute. If the wire did not immediately commence to lose heat to its surroundings it would soon become red hot.

If the steel wire actually were to increase its temperature at the rate of 20 degrees per minute, due to the current flow of one ampere, the resistance of the wire would increase at the rate of about 7 ohms per minute. Instead of the original resistance of 400 ohms we would have a resistance of 407 ohms at the end of one minute, and at the end of ten minutes would have 470 ohms of resistance.

**Watts Dissipation of Resistors.** When you specify a resistor for use in an electrical circuit it is not enough to give only the number of ohms required, but you must specify also the "watts dissipation" or the rating of the resistor in watts. The watts dissipation is the number of watts of power that may be used up in the resistor without causing its temperature to rise so high as to endanger surrounding materials or the resistor itself.

The watts rating of a resistor is the maximum number of watts of power that it will dissipate or use up without causing a temperature rise of more than 250 degrees centigrade, which is equal to 450 degrees Fahrenheit, when the resistor is surrounded by at least one foot of free air space on all sides, and when the starting temperature is 40° C. or 104° F.

You might find that a 1000-ohm resistor is to carry a current flow of 300 milliamperes, which is a flow of 0.3 amperes. Then,

$$I^2R \text{ will be } 0.3 \times 0.3 \times 1000 = 90 \text{ watts.}$$

In this resistor the actual power dissipation will be 90 watts, and to prevent overheating we might select a unit rated at least at 100 watts. If the resistor were to be used in a confined space where heat could not be carried away readily by circulation of air around the resistor, we should select a unit rated at 150 or 200 watts. When a resistor of higher wattage rating is used, its operating temperature will not be excessive

## RESISTORS AND RESISTANCE

even though the heat cannot be carried away at a rapid rate.

**Duty Cycle.** The time during which a resistor carries current, in relation to the total time, is called the duty cycle. It may be specified as so many seconds or minutes during some longer time, such as 15 seconds out of 75 seconds. The duty cycle may be specified also as a percentage, such as 20 per cent, which means that the resistor may carry current only during that portion of the total time. Operation on a duty cycle greater than that for which the resistor is rated will quickly cause damaging overheating.

**Rheostat and Potentiometer Ratings.** Rheostats and potentiometers are specified as to the number of ohms of resistance and the number of watts which they will dissipate without overheating. The wattage rating is based on the use of the entire resistance, or the whole length of winding. The maximum current which may be carried is equal to the square root of the number of watts divided by the number of ohms.

For example; assume a 20-watt 1000-ohm unit.

Dividing 20 by 1000 gives 0.02

The square root of 0.02 is 0.14

So the maximum current is 0.14 ampere, or 140 milliamperes for this unit.

If necessary, a fixed resistor must be connected in series with the rheostat or potentiometer to limit the current to the maximum safe value.

**Resistance Measured with a Voltmeter.** In addition to the unit whose resistance is to be determined it is necessary to have any other known resistance to be used for comparison, also some source of current which may be allowed to flow through the known and the unknown resistance. The current must not be so great as to overheat either resistance unit.

Connect the two resistance units in series to the source of current. Measure the voltage from end to end of each resistance unit. Then,

1. Divide the number of volts across the known resistance unit by the number of ohms resistance in this unit.

2. Divide the number of volts across the unknown resistance by the value obtained in step 1. The result of this division is the number of ohms resistance in the unit.

**Currents and Voltages in a Voltage Divider.** Consider a voltage divider with two connected loads as shown in Fig. 4-3. The first step in analysis is to consider the parallel resistances A and D shown separately at 1 in Fig. 4-4. The equivalent resistance of 1000 ohms and 250 ohms in parallel is 200 ohms, so we may represent resistors A and D as the 200-ohm resistor A-D in diagram 2. The 200 ohms of A-D is in series with voltage divider resistor B, whose resistance

## RESISTORS AND RESISTANCE

is 2800 ohms. Since the resistance of resistors in series is equal to the sum of the separate resistances, we may represent resistors A-D and B as a single 3000-ohm resistance at A-D-B of diagram 3.

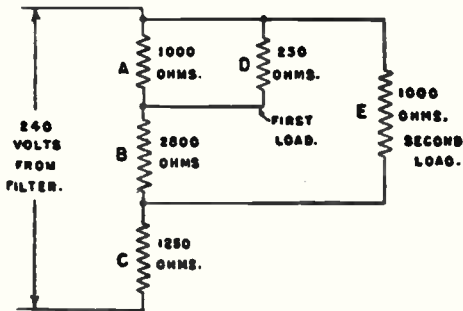


Fig. 4-3. Resistance values assigned to sections of the voltage divider and to the loads.

Our 3000-ohm resistance A-D-B is in parallel with the 1000 ohms of load resistor E, as shown by diagram 1 in Fig. 4-5. The equivalent resistance of 3000 ohms and 1000 ohms in parallel is 750 ohms, as represented by the equivalent resistance A-D-B-E of diagram 2. The equivalent resistance of 750 ohms is in series with voltage divider resistor C of 1250 ohms, so the two together have a total resistance of 2000 ohms, as in diagram 3.

Now we have a potential difference of 240 volts across a combination of resistances equivalent to 2000 ohms. The current flow will be found from the formula  $I = E/R$ . Dividing 240 volts by 2000 ohms

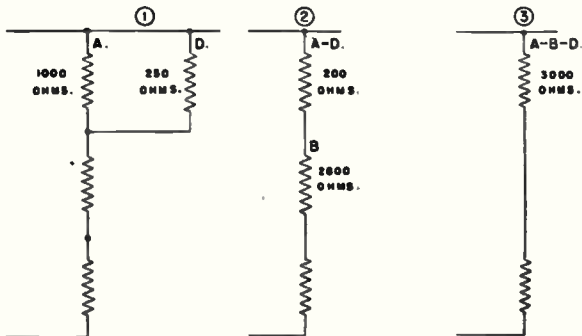


Fig. 4-4. Equivalent values are found for parallel resistances, and these equivalents are considered as being in series with other resistances.



## RESISTORS AND RESISTANCE

gives 240/2000 ampere of current flow, which is equal to 120/1000 or 0.120 ampere, and is the same as 120 milliamperes. When dealing with fractions of amperes it is almost always easier to use the milliampere (1/1000 ampere) as our unit of current flow.

To determine how the total current flow of 120 milliamperes and the total potential difference of 240 volts divide in the resistances of the voltage divider and loads we shall work backward through the diagrams. Diagram 1 of Fig. 4-6 corresponds to diagram 2 of Fig. 4-5. The total potential difference of 240 volts divides proportionately to the resistances, so in equivalent resistance A-D-B-E we have 90 volts potential difference and in resistor C have 150 volts. The current flow must be the same, 120 milliamperes, in these series resistances.

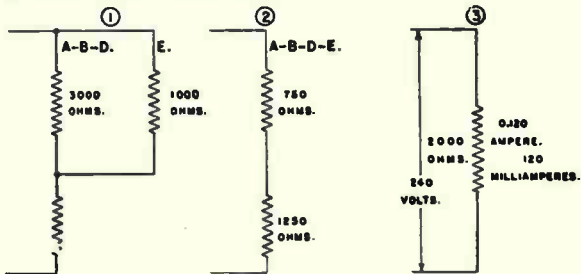


Fig. 4-5. Continuing with equivalent resistances for units in parallel, and determining total resistance for parts in series, reduces the voltage divider to a single equivalent resistance in which the rate of current flow is easily determined.

In diagram 2 of Fig. 4-6 we have separated the resistances into the equivalent A-D-B of 3000 ohms, and load resistor E of 1000 ohms. Potential difference is the same across resistances in parallel, so here we have a potential difference of 90 volts across the 3000 ohms of A-B-D, and have 90 volts across the 1000 ohms of E. To determine the rates of current flow in A-D-B and in E we may use Ohm's law for current flow,  $I = E/R$ , as follows:

$$\text{In A-D-B } I = 90/3000 = 30/1000 \text{ ampere,} \\ 30 \text{ milliamperes.}$$

$$\text{In E } I = 90/1000 = 90/1000 \text{ ampere,} \\ 90 \text{ milliamperes.}$$

Note that the ratio of resistances in A-D-B and E is 3000 to 1000, or 3000/1000, or 3 to 1. Note that the ratio of current flows in A-D-B and E is 30 to 90, or 3/9, or 1 to 3. Current flows in parallel resistances are inversely proportional to the respective resistances, meaning that inverting the ratio of resistances gives the ratio of current flows, and vice versa.

## RESISTORS AND RESISTANCE

In diagram 1 of Fig. 4-7 (corresponding to 2 of Fig. 4-4) we have separated resistances A-D with 200 ohms and B with 2800 ohms. The total potential difference of 90 volts divides in proportion to the re-

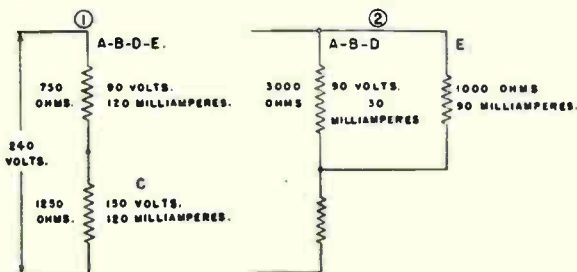


Fig. 4-6. Separating series resistances, and dividing equivalent resistances into their parallel parts, allows determining current flows and potential differences across the parts.

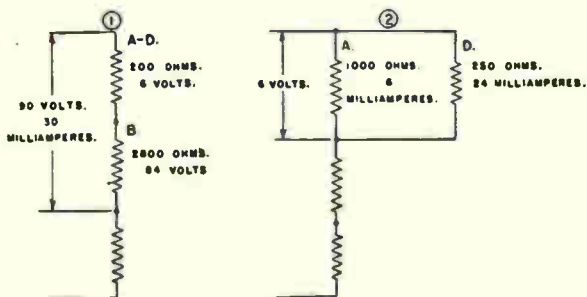


Fig. 4-7. Current flow rates and potential differences finally are determined for all the resistances of the voltage divider and loads.

sistances, so we have a 6-volt drop across A-D and an 84-volt drop across B. The current flow of 30-milliamperes goes through both the series resistances.

In diagram 2 of Fig. 4-7 (corresponding to 1 of Fig. 4-4) we have separated the parallel resistances A and D. The total current flow of 30 milliamperes divides inversely as the resistances in ohms, so we have 6 milliamperes in the 1000 ohms of resistance A, and have 24 milliamperes in the 250 ohms of resistance D. Note that the ratio of the resistances A and D is 1000/250 or 4/1, and that the ratio of the current flows is 6/24 or 1/4. We simply invert the ratio of resistances to find the ratio of current flows. The potential difference is, of course, the same across these two resistances which are in parallel.

## RESISTORS AND RESISTANCE

Now we have determined the current flows in milliamperes and the potential differences in volts for both loads and for every section of the voltage divider. Whenever you work with circuits containing resistances both in series and in parallel it is necessary first to change the parallel resistances into equivalent resistances, then to consider the equivalent resistances as being in series with other parts of the circuit.

### RESISTOR TROUBLES

**Open circuit, resistor burned out.** High ambient temperature, due to lack of air circulation, or to being too close to other parts of the apparatus which prevents heat radiation.

Resistor which should be used only part time (as for starting) stays in circuit too long.

Wattage rating too low, or not suited to duty cycle.

**Shorts or grounds, insulation defective.** Excessively high voltage or current flow.

Long continued overheating, but not great enough to cause burnout.

Moisture, dirt, oil or corrosive spray and fumes.

Mechanical damage due to carelessness.

**Adjustable voltage dividers and rheostats.** Same troubles as for resistors, above, also:

Poor contact between slider and winding.

Defective connection from stationary terminal to slider.

Dirty or corroded contacts at taps.

### COLOR CODING OF RESISTORS

Small resistors and capacitors are often marked with dots or bands of color to indicate their values as an aid to both repair man and manufacturer. Components too small to have the actual values printed upon them are easily color-coded, and have the further advantage that these bands of color can be seen at all times without the probable necessity of turning the units over or otherwise searching for the printed value. The standards Committee of RMA (Radio Manufacturers' Association) has standardized a group of colors with numerical equivalents as follows:

0 = Black	5 = Green
1 = Brown	6 = Blue
2 = Red	7 = Violet
3 = Orange	8 = Gray
4 = Yellow	9 = White

This color code is standard for all resistors and capacitors, although there are several systems employed in its use. In general, however, several dots or bands of color are used to indicate the **significant**

## RESISTORS AND RESISTANCE

figures of the value, and a final color to indicate where to place the decimal point. This "decimal multiplier" color indicates the number of zeros to be added to the significant figures or, which amounts to the same thing, the power of 10 that the significant figures must be multiplied by in order to properly place the decimal point. Thus, three RED dots indicate the number 2200, the first two dots contributing the 22 part, and the last dot, being the decimal multiplier, indicating that two ZEROS are to be added (or multiply by 10 to the second power) to complete the value. Likewise, the combination red-orange-green-black indicates the number 235. In this case the black decimal multiplier (black 0) means "add NO zeros," or multiply by 1 (10 to the zero power 1).

The original colors have since been supplemented by gold and silver, and the significance of each color has been extended to include tolerance values, capacitor voltage ratings, and capacitor temperature coefficients, as shown in the accompanying table. These additional features of the extended color code may never be employed, however, except in the single case of resistors having five bands to indicate the value to three significant figures in a specific manner which will be shown. For all other applications, gold and silver are never used for any purpose other than to indicate tolerance and, conversely, the tolerance must never be indicated by any color other than gold or silver. In the several accompanying illustrations, the encircled numbers are employed to indicate the relative order and positions of the significant figure colors, that is, 1 = first significant figure, 2 = second, etc. The location of the decimal multiplier color is indicated by x, the tolerance color by %, and the voltage rating of capacitors by v.

Color	Significant figure	X Decimal multiplier	% Tolerance %	V Voltage rating, volts	TC Temperature coefficient
Black	0	1	20		Zero
Brown	1	10 <sup>1</sup>	1	100	-30
Red	2	10 <sup>2</sup>	2	200	-80
Orange	3	10 <sup>3</sup>	3	300	-150
Yellow	4	10 <sup>4</sup>	4	400	-220
Green	5	10 <sup>5</sup>	5	500	-330
Blue	6	10 <sup>6</sup>	6	600	-470
Violet	7	10 <sup>7</sup>	7	700	-750
Gray	8	18 <sup>6</sup>	8	800	
White	9	10 <sup>9</sup>	9	900	Not Specified
Gold		10 <sup>-1</sup>	5	1,000	
Silver		10 <sup>-2</sup>	10	2,000	
No Color			20	500	

## RESISTORS AND RESISTANCE

There are in use two distinct systems for color-coding the values of small fixed composition resistors and, although the first, or "old system," is now obsolete for all resistors except those having "radial" connecting leads (Fig. 4-8, A), many resistors having this type of marking are still in use. The original system consists of painting the entire resistor with a solid **body color** to indicate the first significant figure of the resistance value, which is always expressed in ohms. At the end of the unit, and painted right over the body color, is the **end color** which indicates the second figure. Near the middle of the unit, also painted on top of the body color, is the **dot color** which serves as the decimal multiplier, and consists of a large dot or a band of color. Resistors employing this system of arranging the colors may sometimes be found with a gold or silver "tolerance band" which may appear at either the same or at the opposite end from the "end" color. Inasmuch as there are no blank spaces between adjacent colors, it is obviously unnecessary to paint a red dot or end on a resistor already having a red body color. A resistor that is entirely red without any other markings, then, would have a resistance of 2200 ohms, plus or minus 20%, because its "body," "end," and "dot" colors are all red. Fig. 4-8 shows typical examples of the "old" color code.

The new system is now standard for all fixed composition resistors except those few which have their connecting wires attached radially instead of axially. It is easier to read because the bands always extend entirely around the unit, and the colors are taken in a more logical sequence. The system also permits values to be expressed to more than two significant figures, it being standard to indicate all values to three significant figures unless the tolerance is greater than plus or minus 10%, when two figures are then considered satisfactory. Markings consist of several encircling bands of color having approximately the same width, **with spaces between** them, and which are simply read in the order that they appear on the resistor, always commencing with the band which is painted at the very **end** of the resistor. Three bands are used to indicate the value to two significant figures, and the tolerance **may** be indicated, when desired, by an additional band provided it is of either gold or silver.

To indicate the value to **three** figures the new extended code is used, such units being readily identified by the presence of **five bands** of color. The decimal multiplier and tolerance colors may be of any color listed in the table, but it must be remembered that the resistor must have all **five bands** before the extended

## RESISTORS AND RESISTANCE

code may be employed. Note that the background color of the resistor itself plays no part in the color code, and is not to be confused with the "body color" of the older system. The actual background color of **insulated** resistors (regardless of whether they are of the carbon, composition, or wire-wound type) is usually a light brown or tan, this being the natural color of the bakelite insulating material. Fig. 4-9 illustrates the new method of employing the color code:

The foregoing explanation of the R.M.A. color coding system is taken from reference data of the Radio Matériel School of the Naval Research Laboratory.

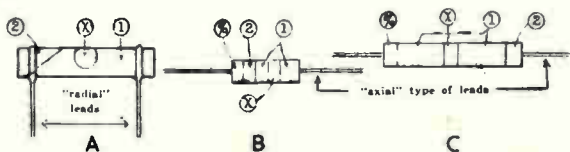


Fig. 4-8



Fig. 4-9

## Section 5

### INSULATION AND INSULATORS

**Insulation.** Any material which has a sufficiently high electrical resistance to permit its use for separating one electrical circuit, part or wire from others. Cotton, silk, baked enamel, mica, porcelain, rubber and bakelite are a few of the common insulating materials used in radio.

**Insulator.** A part made of insulation in a form suitable for supporting electrical conductors or for separating them electrically from other conductors.

**Dielectric.** Any insulating material, but usually one having such exceedingly high electrical resistance as to effectively prevent flow of any current through it. A dielectric used between conductive plates in a condenser receives and retains the electric charge of the condenser. Air, mica, glass and paper are common dielectrics.

**Leakage.** Undesirable flow of current through or over the surface of an insulating material. This term is also used to describe magnetic flux which wanders off into space without doing useful work.

**Leakage Resistance.** The resistance of a path taken by leakage currents. Thus, the leakage resistance of a condenser is the normally high resistance which it offers to the flow of the direct current.

**Dielectric Strength.** The number of volts required to break down or puncture an insulating material, and thus to permit flow of current through the material.

**Breakdown Voltage.** The voltage at which the insulation between two conductors will break down and become conductive.

**Insulating Materials.** There is no such thing as a perfect insulator. The materials commonly used for this purpose have volume resistivities ranging from 10,000 ohms to many billions of ohms between opposite faces of the unit cube. This means that 1 volt impressed across such a unit cube by means of proper metal terminals, would cause a current of from to less than one billionth of an ampere to flow.

Most insulating substances show a decrease in volume resistivity with increase in temperature. These changes are irregular and sometimes rapid. They are not directly proportional to the changes in temperature. Humidity is of great influence, and tends to lower the volume resistivity in such materials as slate, marble, hard fiber, and materials of the phenolic type such as bakelite. Very frequently surface leakage is of greater importance than volume conduction, and

## INSULATION AND INSULATORS

this surface leakage is largely dependent upon the conductivity of the moisture film upon the surface. In any event, care must be taken to ensure that the effects of surface leakage are either minimized or allowed for.

In work involving high potential differences the property of dielectric strength is of greater importance than volume resistivity. If the potential difference applied between opposite sides of a sheet of dielectric material exceeds a certain critical value, the dielectric will break down, as though under a mechanical stress, and a spark will pass between the terminals. In case the insulator is a liquid or a gas, its continuity is immediately restored after the spark has passed. However, in a solid insulator the path of the spark discharge is a permanent defect, and if enough energy is being supplied from the source, a continuous current will persist, which flows along the arc or bridge of vapor formed by the first spark. "Dielectric strength" is a property of the material which resists this tendency to break down. It is measured in terms of volts or kilovolts required to pierce a given thickness of the material and is sometimes called the "puncture voltage." It is a quantity that can not be specified or measured very precisely, because the results vary with (a) the character of the voltage, whether direct or alternating, (b) the distance between the terminals, (c) the time for which the voltage is applied, and (d) the shape of the terminals. The presence of moisture lowers the dielectric strength. Dry air is one of the best of the insulating substances, but its dielectric strength is lower than that of many liquids and solids. The dielectric strength of different specimens of the same insulating material is not directly proportional to the thickness of the specimen.

The properties of most electrical insulating materials are very different when subjected to high-frequency voltage than when subjected to the low-frequency voltage such as is used on house-lighting, or when subjected to direct current. As an example, a piece of insulating material of the phenolic type may withstand 100,000 volts at a frequency of 60 cycles per second, but may deteriorate and become conductive very rapidly when subjected to a voltage of the order of 20,000 volts or less at radio frequencies.

**Insulator Characteristics.** The principal properties of an insulator are,

1. Dielectric strength. The number of volts required to puncture or break down a specified thickness of the insulator. Values given in volts per mil, or in some other unit of thickness, have little meaning unless there is mention of the actual thickness



## INSULATION AND INSULATORS

- tested. Dielectric strength per unit thickness varies greatly with actual thickness.
2. Volume resistivity. Usually given as the ohms of resistance between opposite faces of a cube which measured one centimeter (0.3937 inch) on each edge.
  3. Surface resistivity. Usually given as the ohms of resistance between opposite edges of a piece which is one centimeter square.

### DIELECTRIC STRENGTHS IN VOLTS

Material	Thickness in Inches				
	1/5	1/10	1/25	1/125	1/250
Fibre, hard			7,000		
Mica, Bengal			70,000		22,000
Canada			50,000		15,000
Mycalex	68,000				
Mineralac compound					3,300
Oil					
mineral-sperm			8,500	3,600	
paraffin			16,000	4,300	
transformer					
mineral		30,000			
synthetic		45,000			
Paper					
fish				800	
fish, paraffined				3,600	
kraft, varnished				7,500	
Phenolic					
laminated, XX			20,000		
molded	60,000				
Porcelain					
wet process	56,000				
steatitic	35,000				

### SPARKING VOLTAGES IN AIR

Length of Gap Inches	Volts Between Balls 1 Inch in Diameter	Volts Between Needle Points
0.1	10,000	2,700
.2	17,500	5,400
.3	25,000	8,100
.4	31,000	10,800
.5	36,500	13,500
.6	42,000	16,200
.7	46,000	18,900
.8	49,500	21,600
.9	52,600	24,300
1.0	55,000	27,000

# INSULATION AND INSULATORS

## RESISTIVITIES

Billions of ohms per centimeter cube.

Material	Volume Resistivity	Surface Resistivity
Bakelites	40 to 20,000,000	3 to 8,000,000
Beeswax, yellow	200,000	60,000
Fire, hard	20	5
Glass, plate	20,000	50
Rubber, hard	1,000,000,000	3,000,000
Marble, Italian	100	3
Mica, colorless	2,000,000	20,000
Bengal	50,000	10
molded	1,000,000	50,000
Porcelain, unglazed	300,000	600
Rosin	50,000,000	500,000
Sealing wax	8,000,000	2,000,000
Slate	$\frac{1}{2}$	1/100
Sulphur	100,000,000	7,000,000
Wood, maple paraffined	30	80

**Insulation Resistance Tester.** This test unit was developed in the Coyne shops for use by students and graduates who wish to have a reliable and accurate means for testing insulation resistance.

The unit consists of a 0 to 1 millimeter and a power supply unit to furnish 500 volt pure DC, which is the voltage specified by the American Institute of Electrical Engineers for insulation resistance testing. The power supply unit consists of a transformer, rectifier and filter unit and ballast resistor as shown in diagram below.

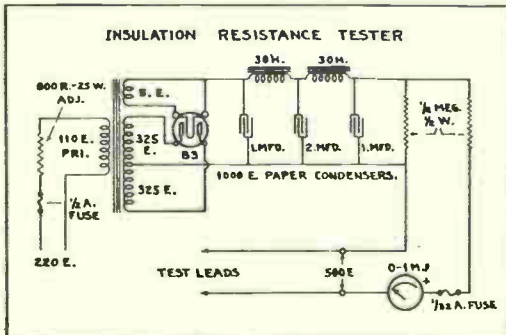


Fig. 5-1

## INSULATION AND INSULATORS

The transformer is a standard radio power pack unit with a 110 volt primary and a 650 volt, 40 M. A. center-tapped secondary for supplying the plates of a full wave rectifier tube; and a 5 volt secondary for the tube filament supply. By using an 800 ohm 25 watt adjustable resistor in the primary circuit this transformer can be operated from 220 volt power circuits if desired. This resistor is not needed for 110 volt operation.

The rectifier tube is a type 83 full wave vacuum tube rectifier. The combination of two 30 henry chokes with two 1 mfd. condensers and one 2 mfd. condenser as shown provide a filter to smooth out the rectified D.C.

The  $\frac{1}{2}$  megohm resistor on the left provides a small constant drain on the tube to maintain a 500 volt pure D.C. output at the high voltage test terminals. The  $\frac{1}{2}$  megohm resistor in series with the meter provides protection against short circuiting in case the test leads should accidentally be touched together.

The fuse in the transformer primary circuit protects the unit against excessive line voltages or possible short circuits in the rectifier or filter condensers. The fuse in series with the meter protects this instrument in case of failure of the series or bleeder resistors, or accidental connection of the test leads to a live power line.

This test unit has a range of zero ohms to 50 megohms and the scale is so arranged that unusual accuracy is obtainable in low ranges from 5 megohms to zero. This permits testing of insulation resistance below one megohm, or in the danger zone for ordinary electric motors and machines.

This tester has been in practical use and operation in our A.C. Power Machinery Department for some time and has proven entirely satisfactory and reliable for insulation resistance testing. We can highly recommend it to electrical maintenance men.

**Insulation Resistance Test With Voltmeter.** The following instructions are adapted from service material issued by the Westinghouse Electric and Mfg. Co.

As shown by Fig. 5-2, a voltmeter is connected through a double-pole, double-throw switch to a d-c source of 500 to 600 volts. The resistance to be measured is connected as shown to the switch.

If a grounded circuit is used in making this measurement, care must be taken to connect the grounded side of the line or power supply to the frame of the apparatus in which insulation resistance is to be measured, and to connect the voltmeter between the part tested and the other side of the circuit.

## INSULATION AND INSULATORS

It is necessary to know the resistance in ohms of the voltmeter, this usually being marked on the meter or in its cover.

A voltage reading is taken while the insulation being tested is in series with the voltmeter. Then the calculation is made as follows:

1. From the line voltage or supply voltage subtract the voltage reading with the insulation in series with the voltmeter.
2. Multiply this difference by the number of ohms resistance of the voltmeter.
3. Multiply by 1,000,000 the voltage reading with the insulation in series with the meter.
4. Divide the product found in step 2 above by the product found in step 3. The result of this division is the insulation resistance in megohms.

For an example: assume a 500-volt d-c supply, a meter reading of 50 volts, and a meter resistance of 500,000 ohms. The steps are,

1.  $500 - 50 = 450$
2.  $450 \times 500,000 = 225,000,000$
3.  $50 \times 1,000,000 = 50,000,000$
4.  $225,000,000 \div 50,000,000 = 4\frac{1}{2}$  megohms.

With the connections made as in Fig. 5-2 the switch would be thrown to the left to measure the supply voltage, then to the right to get the voltage reading with the insulation in series with the meter.

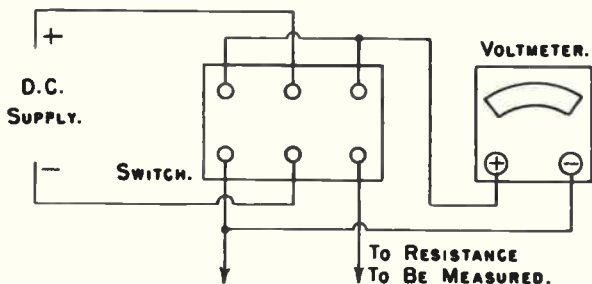


Fig. 5-2

## Section 6

# WIRING METHODS AND MATERIALS

### RACEWAYS

**Note:** Following are many of the more important instructions and recommendations of the National Electrical Code applying to raceway wiring.

**Raceway.** Any enclosure designed for and used only for holding wires, cables or bus-bars; includes all types of conduit, whether of metal or of insulating material, and all similar wire channels.

**Number of Conductors in Raceway.** In general the percentage of the total interior cross-sectional area of a raceway to be occupied by conductors shall not be more than will permit a ready installation or withdrawal of the conductors and dissipation of the heat generated without injury to the insulation of the conductors.

**Inserting Conductors in Raceways.** Raceways, except those used for exposed work and having a removable cover or capping, shall first be installed as a complete raceway system without the conductors. Conductors shall not be inserted until all mechanical work on the building which is liable to injure the conductors has been completed, as far as possible. Pull wires, if used, shall not be installed until the raceway system is in place. Graphite, talc, or an approved compound may be used as a lubricant in inserting conductors in raceways. Cleaning agents or lubricants having a deleterious effect on conductor coverings shall not be used.

**Splices.** Conductors shall be continuous from outlet to outlet and, except as permitted for auxiliary gutters and for wireways, there shall be no splice or tap within the raceway itself.

**Stranded Conductors.** Except when used as bus-bars, conductors of No. 6 and larger, installed in raceways, shall be stranded.

**Raceways Continuous.** Raceways shall be continuous from outlet to outlet and from fitting to fitting.

**Raceways Exposed to Different Temperatures.** If portions of an interior raceway system are exposed to widely different temperatures, as in refrigerating or cold-storage plants, provision shall be made to prevent circulation of air from a warmer to a colder section through the raceway.

**Supporting Conductors in Raceways.** Conductors in vertical raceways shall be supported at intervals not greater than those specified in the following table:

No. 18	to No. 0	.....not greater than 100 feet
No. 00	to No. 0000	.....not greater than 80 feet

## WIRING METHODS AND MATERIALS

250000 C. M. to 350,000 C. M.....	not greater than	60 feet
350001 C. M. to 500,000 C. M.....	not greater than	50 feet
500001 C. M. to 750,000 C. M.....	not greater than	40 feet
Above 750,000 C. M.....	not greater than	35 feet

The following methods of supporting cables are recommended:

a. By clamping devices constructed of or employing insulating wedges inserted in the ends of the conduits.

b. By inserting boxes at the required intervals in which insulating supports are installed and secured in a satisfactory manner to withstand the weight of the conductors attached thereto, the boxes being provided with covers.

c. In junction boxes, by deflecting the cables not less than 90 degrees and carrying them horizontally to a distance not less than twice the diameter of the cable, the cables being carried on two or more insulating supports, and additionally secured thereto by tie wires if desired.

## PROVISIONS APPLYING TO ALL WIRING IN METAL ENCLOSURES

### Alternating-Current Systems in Metal Enclosures.

Where run in metal raceway or cable armor, or where entering metal enclosures, the conductors of circuits operating on alternating-current shall be so arranged as to avoid overheating of the metal by induction. If the capacity of a circuit is such that it is impracticable to run all conductors in one enclosure, additional enclosures may be used provided the conductors in any one enclosure are balanced in size and include one from each phase.

Induced currents in an enclosure can be avoided by so grouping the conductors in one enclosure that the current in one direction will be substantially equal to the current in the opposite direction.

In the case of circuits supplying vacuum or gas-tube lighting systems or signs or X-ray apparatus, and under-plaster extensions permitted, the currents carried by the conductors are so small that a single conductor may be placed in a metal raceway or cable armor without causing trouble from induction.

**Electrical Continuity of Raceways.** Interior metal raceways, cable armor, and other metal enclosures for conductors, shall be metallically joined together into a continuous electrical conductor, and shall be so connected to all boxes, fittings and cabinets as to provide effective electrical continuity.

The following list showing diameters and cross sectional areas of insulated conductors gives data which is useful when determining the size or number of conductors which may be placed in an enclosure.

## WIRING METHODS AND MATERIALS

### DIMENSIONS OF RUBBER-COVERED CONDUCTORS

Types R, RW, RP, and RH

Size AWG-CM	Approx. Diam. Inches	Approx. Area Sq. Ins.	Size CM	Approx. Diam. Inches	Approx. Area Sq. Ins.
18	.14	.0154	450,000	1.08	.91
16	.15	.018	500,000	1.12	.99
14	.20	.031	550,000	1.17	1.08
12	.22	.038	600,000	1.22	1.16
10	.24	.045			
8	.30	.071	650,000	1.25	1.23
			700,000	1.29	1.30
6	.41	.13	750,000	1.33	1.38
4	.45	.16	800,000	1.36	1.45
2	.52	.21			
1	.59	.27	850,000	1.39	1.52
			900,000	1.43	1.60
0	.63	.31	950,000	1.46	1.68
00	.67	.35	1,000,000	1.49	1.75
000	.72	.41			
0000	.78	.48	1,250,000	1.68	2.22
250,000	.86	.58	1,500,000	1.79	2.52
300,000	.92	.67	1,750,000	1.90	2.85
350,000	.98	.75	2,000,000	2.00	3.14
400,000	1.03	.83			

No. 18 to No. 8, solid conductor, No. 6 and larger, stranded.

### Small Diameter Building Wires, Types RHT and RPT

Size AWG	Approx. Diam. Inches	Approx. Area Sq. Ins.	Size AWG	Approx. Diam. Inches	Approx. Area Sq. Ins.
14	.162	.0206	10	.200	.0314
12	.179	.0252	8	.261	.0535

Note—Small diameter building wire, Type RPT, recognized in sizes Nos. 14, 12 and 10. No. 14 to No. 8, solid conductors.

**RIGID METAL CONDUIT.** Piping or heavy tubing of mild steel having pipe-thread ends and used with similarly threaded fittings for the enclosure and support of insulated wires in an electrical system.

**Use.** Rigid metal conduit may be used under all atmospheric conditions and occupancies, except that steel or iron conduit and fittings protected from corrosion solely by enamel may be used only indoors and in occupancies not subject to severe corrosive influences. Conduits and fittings exposed to severe corrosive influences shall be of corrosion-resistant material suitable for the conditions. If practicable, the use of dissimilar metals throughout the system shall be avoided to eliminate the possibility of galvanic action.

## WIRING METHODS AND MATERIALS

Meat-packing plants, tanneries, hide cellars, casing rooms, glue houses, fertilizer rooms, salt storage, some chemical works, metal refineries, pulp and paper mills, sugar mills, round houses, some stables, and similar locations are judged to be occupancies where severe corrosive conditions are likely to be present.

**Cinder Fill.** Conduit, unless of corrosion-resistant material suitable for the purpose, shall not be used in or under cinder fill where subject to permanent moisture unless protected on all sides by a layer of non-cinder concrete at least 2 inches thick or unless the conduit is at least 18 inches under the fill.

**Wet Locations.** In portions of dairies, laundries, canneries, and other wet locations, and in locations where walls are frequently washed, the entire conduit system, including all boxes and fittings used therewith, shall be made watertight.

**Minimum Size.** No conduit smaller than  $\frac{1}{2}$  inch, electrical trade size, shall be used, except as provided for under-plaster extensions and for enclosing the leads of fractional-horsepower motors as permitted.

### DIMENSIONS OF CONDUIT OR TUBING

Size	Internal Diameter Inches	Area Square Inches	Size	Internal Diameter Inches	Area Square Inches
$\frac{1}{8}$	.622	.30	3	3.068	7.38
$\frac{3}{8}$	.824	.53	$3\frac{1}{2}$	3.548	9.90
1	1.049	.86	4	4.026	12.72
$1\frac{1}{4}$	1.380	1.50	$4\frac{1}{2}$	4.506	15.95
$1\frac{1}{2}$	1.610	2.04	5	5.047	20.00
2	2.067	3.36	6	6.065	28.89
$2\frac{1}{2}$	2.489	4.79			

### DIMENSIONS OF CONDUIT

Conduit	Area	40% of Area	Conduit	Area	40% of Area
$\frac{1}{8}$	.306	.122	3	7.34	2.93
$\frac{3}{8}$	.516	.206	$3\frac{1}{2}$	9.94	3.97
1	.848	.339	4	12.7	5.08
$1\frac{1}{4}$	1.49	.596	$4\frac{1}{2}$	15.9	6.36
$1\frac{1}{2}$	2.03	.812	5	19.9	7.96
2	3.32	1.328	6	28.8	11.52
$2\frac{1}{2}$	4.75	1.9			

This table gives both the total area of the inside opening in conduit, and 40% of the area of the different sizes, which is the amount that can be occupied by the conductors.

**Number of Conductors in Conduit or Tubing.** The following tables showing the number of conductors permitted in conduit or tubing apply only to complete conduit systems. They do not apply to short sections of conduit used for the protection of exposed wiring from mechanical injury.



## WIRING METHODS AND MATERIALS

The first table (1 to 9 conductors) applies to Type RHT small diameter building wire except for rewiring in existing raceways.

Where a run of conduit or electrical metallic tubing does not exceed 50 feet in length and does not contain more than the equivalent of two quarter-bends from end to end: three No. 6 stranded conductors may be installed in a 1-inch conduit or tubing. For services only, three No. 8 insulated conductors may be installed in a  $\frac{3}{4}$ -inch conduit or tubing; two No. 6 insulated and one No. 6, bare conductors or two No. 4 insulated and one No. 4 bare conductors may be installed in 1-inch conduit or tubing; and two No. 2, insulated and one No. 2, bare conductors in  $1\frac{1}{4}$ -inch conduit or tubing.

### NUMBER OF CONDUCTORS IN CONDUIT OR TUBING

One to Nine Conductors Rubber-Covered—  
Types R, RW, RP, RH, and RHT—600 V.

Size of Conductor	Number of Conductors in One Conduit or Tubing								
	1	2	3	4	5	6	7	8	9
No. 18	$\frac{1}{2}$	$\frac{1}{2}$	$\frac{3}{8}$	$\frac{1}{2}$	$\frac{1}{2}$	$\frac{3}{8}$	$\frac{3}{8}$	$\frac{1}{2}$	$\frac{3}{8}$
16	$\frac{1}{2}$	$\frac{1}{2}$	$\frac{1}{2}$	$\frac{1}{2}$	$\frac{1}{2}$	$\frac{1}{2}$	$\frac{1}{2}$	$\frac{1}{2}$	$\frac{1}{2}$
14	$\frac{1}{2}$	$\frac{1}{2}$	$\frac{1}{2}$	$\frac{1}{2}$	$\frac{3}{4}$	$\frac{3}{4}$	1	1	1
12	$\frac{1}{2}$	$\frac{1}{2}$	$\frac{1}{2}$	$\frac{3}{4}$	$\frac{3}{4}$	1	1	1	$1\frac{1}{4}$
10	$\frac{1}{2}$	$\frac{1}{2}$	$\frac{3}{4}$	$\frac{3}{4}$	1	1	$\frac{1}{2}$	$\frac{1}{2}$	$\frac{1}{2}$
8	$\frac{1}{2}$	$\frac{3}{4}$	*1	1	$1\frac{1}{4}$	$1\frac{1}{4}$	$1\frac{1}{4}$	$1\frac{1}{4}$	$1\frac{1}{4}$
6	$\frac{1}{2}$	1	* $1\frac{1}{4}$	$1\frac{1}{4}$	$1\frac{1}{2}$	$1\frac{1}{2}$	2	2	2
5	$\frac{1}{2}$	$1\frac{1}{4}$	$1\frac{1}{4}$	$1\frac{1}{4}$	$1\frac{1}{2}$	2	2	2	2
4	$\frac{1}{2}$	$1\frac{1}{4}$	* $1\frac{1}{4}$	$1\frac{1}{2}$	2	2	2	2	$2\frac{1}{2}$
3	$\frac{3}{4}$	$1\frac{1}{4}$	$1\frac{1}{4}$	$1\frac{1}{2}$	2	2	2	$2\frac{1}{2}$	$2\frac{1}{2}$
2	$\frac{3}{4}$	$1\frac{1}{4}$	$\frac{1}{2}$	$1\frac{1}{2}$	2	2	$2\frac{1}{2}$	$2\frac{1}{2}$	$2\frac{1}{2}$
1	$\frac{3}{4}$	$1\frac{1}{2}$	$1\frac{1}{2}$	2	2	$2\frac{1}{2}$	$2\frac{1}{2}$	3	3
0	1	$1\frac{1}{2}$	2	2	$2\frac{1}{2}$	$2\frac{1}{2}$	3	3	3
00	1	2	2	$2\frac{1}{2}$	$2\frac{1}{2}$	3	3	3	$3\frac{1}{2}$
000	1	2	2	$2\frac{1}{2}$	3	3	3	$3\frac{1}{2}$	$3\frac{1}{2}$
0000	$1\frac{1}{4}$	2	$\frac{1}{2}$	$2\frac{1}{2}$	3	3	$3\frac{1}{2}$	$3\frac{1}{2}$	4
250000	$1\frac{1}{4}$	$2\frac{1}{2}$	$2\frac{1}{2}$	3	3	$3\frac{1}{2}$	$\frac{1}{2}$	$\frac{1}{2}$	$\frac{1}{2}$
300000	$1\frac{1}{4}$	$2\frac{1}{2}$	$\frac{1}{2}$	3	$3\frac{1}{2}$	$3\frac{1}{2}$	$\frac{1}{2}$	$\frac{1}{2}$	$\frac{1}{2}$
350000	$1\frac{1}{4}$	$2\frac{1}{2}$	3	$3\frac{1}{2}$	$3\frac{1}{2}$	4	$\frac{1}{2}$	$\frac{1}{2}$	$\frac{1}{2}$
400000	$\frac{1}{2}$	3	3	$3\frac{1}{2}$	4	4	$\frac{1}{2}$	$\frac{1}{2}$	$\frac{1}{2}$
450000	$1\frac{1}{2}$	3	3	$3\frac{1}{2}$	4	$4\frac{1}{2}$	$\frac{1}{2}$	$\frac{1}{2}$	$\frac{1}{2}$
500000	$1\frac{1}{2}$	3	3	$3\frac{1}{2}$	4	$4\frac{1}{2}$	$\frac{1}{2}$	$\frac{1}{2}$	$\frac{1}{2}$
550000	$1\frac{1}{2}$	3	$3\frac{1}{2}$	4	$4\frac{1}{2}$	5	$\frac{1}{2}$	$\frac{1}{2}$	$\frac{1}{2}$
600000	2	3	$3\frac{1}{2}$	4	$4\frac{1}{2}$	5	$\frac{1}{2}$	$\frac{1}{2}$	$\frac{1}{2}$
650000	2	$3\frac{1}{2}$	$3\frac{1}{2}$	4	$\frac{1}{2}$	$\frac{1}{2}$	$\frac{1}{2}$	$\frac{1}{2}$	$\frac{1}{2}$
700000	2	$3\frac{1}{2}$	$3\frac{1}{2}$	$4\frac{1}{2}$	$\frac{1}{2}$	$\frac{1}{2}$	$\frac{1}{2}$	$\frac{1}{2}$	$\frac{1}{2}$
750000	2	$3\frac{1}{2}$	$3\frac{1}{2}$	$4\frac{1}{2}$	$\frac{1}{2}$	$\frac{1}{2}$	$\frac{1}{2}$	$\frac{1}{2}$	$\frac{1}{2}$
800000	2	$3\frac{1}{2}$	4	$4\frac{1}{2}$	$\frac{1}{2}$	$\frac{1}{2}$	$\frac{1}{2}$	$\frac{1}{2}$	$\frac{1}{2}$
850000	2	$3\frac{1}{2}$	4	$4\frac{1}{2}$	$\frac{1}{2}$	$\frac{1}{2}$	$\frac{1}{2}$	$\frac{1}{2}$	$\frac{1}{2}$
900000	2	$3\frac{1}{2}$	4	$4\frac{1}{2}$	$\frac{1}{2}$	$\frac{1}{2}$	$\frac{1}{2}$	$\frac{1}{2}$	$\frac{1}{2}$
950000	2	4	4	5	$\frac{1}{2}$	$\frac{1}{2}$	$\frac{1}{2}$	$\frac{1}{2}$	$\frac{1}{2}$
1000000	2	4	4	5	$\frac{1}{2}$	$\frac{1}{2}$	$\frac{1}{2}$	$\frac{1}{2}$	$\frac{1}{2}$
1250000	$2\frac{1}{2}$	$4\frac{1}{2}$	$4\frac{1}{2}$	6	$\frac{1}{2}$	$\frac{1}{2}$	$\frac{1}{2}$	$\frac{1}{2}$	$\frac{1}{2}$
1500000	$2\frac{1}{2}$	$4\frac{1}{2}$	5	6	$\frac{1}{2}$	$\frac{1}{2}$	$\frac{1}{2}$	$\frac{1}{2}$	$\frac{1}{2}$
1750000	3	5	5	6	$\frac{1}{2}$	$\frac{1}{2}$	$\frac{1}{2}$	$\frac{1}{2}$	$\frac{1}{2}$
2000000	3	5	6	$\frac{1}{2}$	$\frac{1}{2}$	$\frac{1}{2}$	$\frac{1}{2}$	$\frac{1}{2}$	$\frac{1}{2}$

Note change in the above table as shown by †.

# WIRING METHODS AND MATERIALS

## NUMBER OF CONDUCTORS IN CONDUIT OR TUBING

Lead-Covered Types RL, RPL and RHL—600 V.

Size of Conductor	Number of Conductors in One Conduit or Tubing											
	Single Conductor Cable				2-Conductor Cable				3-Conductor Cable			
	1	2	3	4	1	2	3	4	1	2	3	4
14	1½	¾	¾	1	½	1	1	1¼	¾	1¼	1½	1½
12	1½	¾	¾	1	¾	1	1¼	1¼	1	1¼	1½	2
10	1½	¾	1	1	¾	1¼	1¼	1½	1	1½	2	2
8	1½	1	1¼	1½	1	1¼	1½	2	1	?	2	2½
6	¾	1¼	1½	1½	1¼	1½	2	2½	1¼	2½	3	3
4	¾	1¼	1½	1½	1¼	2	2½	2½	1½	3	3	3½
3	¾	1¼	1½	2	1¼	2	2½	3	1½	3	3	3½
2	1	1¼	1½	2	1¼	2	2½	3	1½	3	3½	4
1	1	1½	2	2	1½	2½	3	3½	2	3½	4	4½
0	1	2	2	2½	2	2½	3	3½	2	4	4½	5
00	1	2	2	2½	2	3	3½	4	2½	4	4½	5
000	1¼	2	2½	2½	2	3	3½	4	2½	4½	4½	6
0000	1¼	2½	2½	3	2½	3	3½	4½	3	5	6	6
250,000	1¼	2½	3	3	...	...	...	...	3	6	6	...
300,000	1½	3	3	3½	...	...	...	...	3½	6	6	...
350,000	1½	3	3	3½	...	...	...	...	3½	6	6	...
400,000	1½	3	3	3½	...	...	...	...	3½	6	6	...
450,000	1½	3	3	4	...	...	...	...	4	6	6	...
500,000	1½	3	3½	4	...	...	...	...	4	6	...	...
600,000	2	3½	4	4½	...	...	...	...	...	...	...	...
700,000	2	4	4	5	...	...	...	...	...	...	...	...
750,000	2	4	4	5	...	...	...	...	...	...	...	...
800,000	2	4	4½	5	...	...	...	...	...	...	...	...
900,000	2½	4	4½	5	...	...	...	...	...	...	...	...
1,000,000	2½	4½	4½	6	...	...	...	...	...	...	...	...
1,250,000	3	5	5	6	...	...	...	...	...	...	...	...
1,500,000	3	5	6	6	...	...	...	...	...	...	...	...
1,750,000	3	6	6	6	...	...	...	...	...	...	...	...
2,000,000	3½	6	6	...	...	...	...	...	...	...	...	...

The above sizes apply to straight runs or with nominal offsets equivalent to not more than two quarter-bends.

It is recommended that bends have a minimum radius of curvature at the inner edge of the bend of not less than 10 times the internal diameter of the conduit or tubing.

# WIRING METHODS AND MATERIALS

## NUMBER OF CONDUCTORS IN CONDUIT OR TUBING

**Small Diameter Building Wire, Types RHT and RPT,  
600 Volts**

**One to Nine Conductors**

For rewiring in existing raceways

Size of Conductor	Number of Conductors in One Conduit or Tubing								
	1	2	3	4	5	6	7	8	9
14	$\frac{1}{2}$	$\frac{1}{2}$	$\frac{1}{2}$	$\frac{1}{2}$	$\frac{1}{2}$	$\frac{1}{2}$	$\frac{1}{2}$	$\frac{3}{4}$	$\frac{3}{4}$
12	$\frac{1}{2}$	$\frac{1}{2}$	$\frac{1}{2}$	$\frac{1}{2}$	$\frac{1}{2}$	$\frac{1}{2}$	$\frac{3}{4}$	$\frac{3}{4}$	$\frac{3}{4}$
10	$\frac{1}{2}$	$\frac{1}{2}$	$\frac{1}{2}$	$\frac{1}{2}$	$\frac{1}{2}$	$\frac{1}{2}$	$\frac{3}{4}$	$\frac{3}{4}$	$\frac{3}{4}$
8	$\frac{1}{2}$	$\frac{1}{2}$	$\frac{3}{4}$	$\frac{3}{4}$	1	1	1	1	$1\frac{1}{4}$

Note.—Type RHT conductor recognized in sizes No. 14 to No. 8;  
Type RPT conductor recognized in sizes No. 14 to No. 10.

## NUMBER OF CONDUCTORS IN CONDUIT OR TUBING

**Synthetic, Type SN and Type RU, 600 Volts**

**One to Nine Conductors**

For rewiring in existing raceways

Size of Conductor	Number of Conductors in One Conduit or Tubing								
	1	2	3	4	5	6	7	8	9
14	$\frac{1}{2}$	$\frac{1}{2}$	$\frac{1}{2}$	$\frac{1}{2}$	$\frac{1}{2}$	$\frac{1}{2}$	$\frac{1}{2}$	$\frac{1}{2}$	$\frac{1}{2}$
12	$\frac{1}{2}$	$\frac{1}{2}$	$\frac{1}{2}$	$\frac{1}{2}$	$\frac{1}{2}$	$\frac{1}{2}$	$\frac{1}{2}$	$\frac{1}{2}$	$\frac{1}{2}$
10	$\frac{1}{2}$	$\frac{1}{2}$	$\frac{1}{2}$	$\frac{1}{2}$	$\frac{1}{2}$	$\frac{1}{2}$	$\frac{1}{2}$	$\frac{1}{2}$	$\frac{1}{2}$
8	$\frac{1}{2}$	$\frac{1}{2}$	$\frac{1}{2}$	$\frac{3}{4}$	$\frac{3}{4}$	$\frac{3}{4}$	1	1	1
6	$\frac{3}{4}$	$\frac{3}{4}$	$\frac{3}{4}$	1	1	$1\frac{1}{4}$	$1\frac{1}{4}$	$1\frac{1}{4}$	$1\frac{1}{4}$
5	$\frac{3}{4}$	$\frac{3}{4}$	$\frac{3}{4}$	1	$1\frac{1}{4}$	$1\frac{1}{4}$	$1\frac{1}{4}$	$1\frac{1}{4}$	$1\frac{1}{4}$
4	$\frac{3}{4}$	$\frac{3}{4}$	1	1	$1\frac{1}{4}$	$1\frac{1}{4}$	$1\frac{1}{4}$	$1\frac{1}{4}$	$1\frac{1}{4}$
3	$\frac{3}{4}$	1	1	$1\frac{1}{4}$	$1\frac{1}{4}$	$1\frac{1}{4}$	$1\frac{1}{4}$	$1\frac{1}{4}$	2
2	$\frac{3}{4}$	1	1	$1\frac{1}{4}$	$1\frac{1}{4}$	$1\frac{1}{4}$	$1\frac{1}{4}$	2	2
1	$\frac{3}{4}$	$1\frac{1}{4}$	$1\frac{1}{4}$	$1\frac{1}{4}$	$1\frac{1}{4}$	2	2	2	$2\frac{1}{4}$
0	$\frac{3}{4}$	$1\frac{1}{4}$	$1\frac{1}{4}$	$1\frac{1}{4}$	2	2	2	$2\frac{1}{4}$	$2\frac{1}{4}$
00	$\frac{3}{4}$	$1\frac{1}{4}$	$1\frac{1}{4}$	2	2	2	$2\frac{1}{4}$	$2\frac{1}{4}$	$2\frac{1}{4}$
000	$\frac{3}{4}$	$1\frac{1}{4}$	$1\frac{1}{4}$	2	2	$2\frac{1}{4}$	$2\frac{1}{4}$	3	3
0000	1	$1\frac{1}{4}$	2	2	$2\frac{1}{4}$	$2\frac{1}{4}$	3	3	3

Note.—Type SN conductors recognized in sizes No. 14 to No. 0000;  
Type RU conductors recognized in sizes No. 14 to No. 10.

Type SN conductors without an outer covering and Type RU conductors with an outer covering have the same overall diameter.

## WIRING METHODS AND MATERIALS

### NUMBER OF CONDUCTORS IN CONDUIT OR TUBING

#### More Than Nine Conductors

Rubber-Covered Types R, RW, RP, and RH—600 V.

\*When Specifically Permitted by This Code

Size of Conductor.	Maximum Number of Conductors in Conduit or Tubing						
	Inch $\frac{3}{4}$	Inch 1	Inch $1\frac{1}{4}$	Inch $1\frac{1}{2}$	Inch 2	Inch $2\frac{1}{2}$	Inch 3
18	18	22	38	53	87	124	191
16	11	19	33	45	74	106	163
14		11	19	26	48	61	95
12			15	21	34	50	77
10			12	16	27	38	60
8				13	22	31	49
6						14	22

\*More than nine conductors are permitted in a single conduit for conductors between a motor and its controller; stage pocket and border circuits, sign flashers, elevator control conductors, signal and control circuits, in accordance with special instructions in sections of the Code applying to such installations.

#### Combination of Conductors

For groups or combinations of conductors not included in the preceding tables, it is recommended that the conduit or tubing be of such size that the sum of the cross-sectional areas of the individual conductors will not be more than the percentage of the interior cross-sectional area of the conduit or tubing than as shown in the accompanying table:

#### Per Cent Area of Conduit or Tubing

	Number of Conductors				
	1	2	3	4	Over 4
*Conductors (not lead covered).	53	31	43	40	40
Lead-covered conductors . . . . .	55	30	40	38	35
For rewiring existing raceways with thinner insulated conductors as provided in 3005-d and e . . . .	60	40	50	50	50

**ELECTRICAL METALLIC TUBING.** This is thin-walled light-weight metallic tubing having the same internal diameters as rigid metal conduit but smaller external diameters.

**Use.** Electrical metallic tubing may be used for both exposed and concealed work. Electrical metallic tubing shall not be used (1) where during installation or afterwards, it will be subject to severe mechanical in-

## WIRING METHODS AND MATERIALS

jury; (2) in cinder concrete or fill unless protected on all sides by a layer of non-cinder concrete at least 2 inches thick or unless the tubing is at least 18 inches under the fill; (3) in any hazardous locations; (4) where exposed to corrosive vapor except as permitted below.

**Corrosive Fumes.** If tubing is exposed to corrosive fumes or vapors such as may exist in meat-packing plants, tanneries, hide cellars, casing rooms, glue houses, fertilizer rooms, salt storage, some chemical works, metal refineries, pulp mills, sugar mills, round houses, some stables, and similar locations, tubing and fittings of corrosion-resistant material suitable for the conditions shall be used. If practicable, the use of dissimilar metals throughout the system shall be avoided to eliminate the possibility of galvanic action.

**Wet Locations.** In portions of dairies, laundries, canneries, and other wet locations, and in locations where walls are frequently washed, the entire tubing system, including all boxes and fittings used therewith, shall be made watertight.

**Minimum and Maximum Sizes.** No tubing smaller than  $\frac{1}{2}$  inch, electrical trade size, shall be used except as provided for underplaster extensions and for enclosing the leads of fractional horsepower motors as permitted. The maximum size of tubing shall be the 2-inch electrical trade size.

**Threads.** Tubing shall not be coupled together nor connected to boxes, fittings, or cabinets by means of threads in the wall of the tubing, except by fittings approved for the purpose. Threads shall not be of standard pipe thread dimensions.

**Couplings and Connectors.** Threadless couplings and connectors used with tubing shall be made up tight, and shall be of the watertight type if buried in masonry, concrete or fill or if installed in wet places.

**Conductor Size.** Tubing shall not be used to contain conductors larger than No. 0.

Number of conductors in tubing is the same as for similar trade sizes of rigid metal conduit.

**FLEXIBLE METAL CONDUIT.** Flexible metallic tubing formed by an interlocking spiral winding of galvanized steel. Wires are drawn in.

**Use.** Flexible metal conduit shall not be used (1) in wet locations, unless conductors are of the lead-covered type or of other type specially approved for the conditions; (2) in hoistways, except as specially permitted; (3) in storage-battery rooms; (4) in any hazardous location except as permitted for flexible connection to motors; nor (5) where rubber-covered conductors are exposed to oil, gasoline, or other materials having a deteriorating effect on rubber.

## WIRING METHODS AND MATERIALS

**SURFACE METAL RACEWAY.** Thin-walled flat covering and support for insulated wires. For mounting on the exposed surfaces of building members, and usually having a removable cover.

**Use.** Surface metal raceway may be used in dry locations. It shall not be used (1) where concealed, except that the back and sides of multi-outlet assembly may be surrounded by the building finish; and metal raceways approved for the purpose may be used for under-plaster extensions; (2) where subject to severe mechanical injury unless approved for the purpose; (3) where the voltage is 300 volts or more between conductors unless the metal has a thickness of not less than .040 inches; (4) where subject to corrosive vapors; (5) in hoistways; (6) in storage-battery rooms; nor (7) in any hazardous location.

**Size of Conductors.** No conductor larger than No. 6 shall be installed in surface metal raceway.

**Number of Conductors in Raceway.** The number of conductors installed in any raceway shall not be greater than the number for which the raceway is approved, and in no case shall more than 10 conductors be installed in a single raceway compartment except as permitted for signal and control systems.

**Extension Through Walls and Floors.** Except in multi-outlet assemblies, raceways may be extended through dry walls, dry partitions and dry floors, if in unbroken lengths where passing through.

**UNDERPLASTER EXTENSIONS.** Flattened metal raceways, rigid or flexible, designed to be placed in a groove cut into plaster or wall finish and then plastered over.

**Use.** Underplaster extensions may be used only for extensions of existing branch circuits, if laid on the face of masonry or other material and buried in the plaster finish of ceilings or walls, in buildings of fire-resistive construction.

**Materials.** Such extensions shall be run in rigid or flexible conduit, armored cable, electrical metallic tubing or metal raceways approved for the purpose. Standard sizes of conduit, cable, tubing and raceways shall be used except that for single conductors only, conduit or tubing having not less than 5/16 inch inside diameter or single-conductor armored cable may be used.

**Limit of Run.** No such extension shall extend beyond the floor on which it originates unless standard sizes of rigid conduit, electrical metallic tubing or armored cable are employed.

**UNDERFLOOR RACEWAYS.** Completely closed metal or fibre raceways embedded in the fill

## WIRING METHODS AND MATERIALS

or in the fill and concrete of floors, or else of open-bottom raceways laid on a smooth pad of concrete within the floor or floor fill.

**Use.** Underfloor raceway may be used when installed beneath the surface of concrete or other flooring material. Open-bottom type of raceways may be used in concrete fill between the rough and the finished floor only. Raceways laid flush with concrete floors and covered with linoleum not less than  $\frac{1}{8}$  inch in thickness or equivalent floor covering, may be used only for signal and control systems. Underfloor raceways shall not be used (1) where subject to corrosive vapors; (2) in any hazardous locations; (3) in commercial garages; nor (4) in storage-battery rooms.

**Covering.** Raceways of half round sections or of flat-top section not over 4 inches in width shall have at least  $\frac{3}{4}$  inch of concrete or wood above the raceway, except in office occupancies metal flat-top raceways not over 2 inches in width may be laid flush with the concrete if covered with substantial linoleum not less than  $\frac{1}{8}$  inch in thickness or equivalent floor covering. Flat-top raceways over 4 inches in width and flat-top raceways placed less than  $\frac{1}{2}$  inch apart, shall be covered with concrete to a depth of at least  $1\frac{1}{2}$  inches.

**Size of Conductors.** No conductor larger than No. 4 shall be installed in underfloor raceways.

**Number of Conductors in Raceway.** The combined cross-sectional area of all conductors shall not exceed 40 per cent of the interior area of the raceway; except that if the raceway contains only armored cable or non-metallic sheathed cable, these requirements shall not apply.

**Splices and Taps.** Splices or taps shall be made only in junction boxes.

**Discontinued Outlets.** Conductors supplying a disconnected outlet shall be removed from the raceway.

**Open-Bottom Raceway—How Laid.** Open-bottom raceway shall be laid on a smooth pad of concrete extending at least 1 inch on each side of the raceway and at least 1 inch thick, except that this thickness may be reduced to  $\frac{1}{4}$  inch where the raceway crosses a run of conduit, and except that in lieu of a concrete pad, fittings which will protect the conductors from contact with piping, structural steel and other obstructions may be used. Raceways shall be mechanically secured to the concrete pad.

**Laid in Straight Lines.** Underfloor raceways shall be laid so that a straight line from the center of one junction box to the center of the next junction box will coincide with the center line of the raceway sys-

## WIRING METHODS AND MATERIALS

tem. Raceways shall be made mechanically secure to prevent disturbing this alignment during construction.

**Markers at Ends.** At every end of line of raceway, a fitting shall be installed extending through the floor to mark the line of the duct. Where a duct line is interrupted by another duct line, but continues in a straight line beyond, and has junction boxes or outlets on either side of the crossing line, no markers are necessary at the interrupting point.

**Dead Ends.** Dead ends of raceways shall be closed.

**Low Points.** Where practicable, raceways and their fittings shall be so arranged as to avoid low points that may form traps for water.

**Junction Boxes.** Junction boxes shall be leveled to the floor grade and sealed against the entrance of water. Junction boxes used with metal raceways shall be metal and shall be electrically continuous with the raceways.

**Inserts.** Inserts shall be leveled to the floor grade and sealed against the entrance of water. Inserts used with metal raceways shall be metal and shall be electrically continuous with the raceway. Inserts set in or on fiber raceways before the floor is laid shall be mechanically secured to the raceway. Inserts set in fiber raceways after the floor is laid shall be screwed into the raceway. In cutting through the raceway wall and setting inserts, chips and other dirt shall not be allowed to fall into the raceway, and tools shall be used which are so designed as to prevent the tool from entering the raceway and injuring conductors that may be in place.

**Connections to Cabinets and Wall Outlets.** Connections between raceways and distribution centers and wall outlets shall be made by means of rigid or flexible metal conduit or by means of fittings specially approved for the purpose.

### **CELLULAR METAL FLOOR RACEWAY.**

Hollow spaces of cellular metal floors, together with suitable fittings, which may be approved as enclosures for electrical conductors; a "cell" is a single, enclosed tubular space in a cellular metal floor member, the axis of the cell being parallel to the axis of the metal floor member; a "header" is a transverse raceway for electrical conductors, providing access to predetermined cells of a cellular metal floor, thereby permitting the installation of electrical conductors from a distribution center to the cells.

**Use.** Conductors shall not be installed in cellular metal floor raceways (1) where subject to corrosive vapor; (2) in any hazardous location; (3) in theaters; (4) in commercial garages, except for supplying ceiling outlets or extensions to the area below the floor



## WIRING METHODS AND MATERIALS

but not above; nor (5) in storage battery rooms. No electric conductors shall be installed in any cell or header which contains a pipe for steam, water, air, gas, drainage, or other service than electrical.

**Size of Conductors.** No conductor larger than No. 0 shall be installed, except by special permission.

**Splices and Taps.** Splices and taps shall be made only in header access units or junction boxes.

**Markers.** A suitable number of markers shall be installed extending through the floor for the future locating of cells and for system identification.

**Inserts.** Inserts shall be levelled to the floor grade and sealed against the entrance of water. Inserts shall be of metal and shall be electrically continuous with the raceway. In cutting through the cell wall and setting inserts, chips and other dirt shall not be allowed to fall into the raceway, and tools shall be used which are designed to prevent the tool from entering the cell and injuring the conductors.

Recommendations are in general the same as for underfloor raceways with reference to number of conductors in raceway, discontinued outlets, junction boxes, and connection to cabinets and extensions.

**WIREWAYS.** Wireways consist of sheet metal troughs which are installed as a complete raceway system to receive the conductors.

**Use.** Wireways may be used only for exposed work in dry locations in industrial occupancies and garages. Wireways shall not be used (1) where subject to severe mechanical injury or corrosive vapor; (2) in hoistways; (3) in any hazardous location; nor (4) in storage-battery rooms.

**Size of Conductors.** No conductor larger than 500,000 c.m. shall be installed in any wireway.

**Number of Conductors in Raceway.** Wireways shall not contain more than 30 conductors at any cross section, unless the conductors are for signaling circuits or are control conductors between a motor and its starter and used only for starting duty. The sum of the cross-sectional areas of all contained conductors at any cross section of a wireway shall not exceed 20 per cent of the interior cross-sectional area of the wireway.

**Splices and Taps.** Splices or taps, made and insulated by approved methods, may be located within the wireway if they are accessible by means of hinged covers. The conductors, including splices and taps, shall not fill the wireway to more than 75 per cent of its area.

**Supports.** Wireways shall be securely supported at intervals not exceeding 5 feet, unless specially approved for supports at greater intervals, but in no case shall the distance between supports exceed 10 feet.

## WIRING METHODS AND MATERIALS

**Extension Through Walls.** Wireways may extend transversely through dry walls if in unbroken lengths where passing through.

**Dead-Ends.** Dead-ends of wireways shall be closed.

**Extensions From Wireways.** Extensions from wireways shall be made with rigid or flexible metal conduit, electrical metallic tubing, surface metal raceway or armored cable.

**Busways.** These consist of sheet metal troughs within which are supported bar-shaped conductors or busses on insulators.

**Use.** Busways may be used for exposed work in any dry location. Busways shall not be used (1) where subject to severe mechanical injury or corrosive vapors; (2) in hoistways; (3) in any hazardous location; nor (4) in storage-battery rooms.

Busways may be used for service-entrance conductors.

**Branches from Busways.** Branches from busways shall be made with busways or with rigid or flexible metal conduit, electrical metallic tubing, surface metal raceway, armored cable or, for portable appliances, with suitable cord assemblies approved for hard usage.

**Overcurrent Devices.** Plug-in apparatus has overcurrent protection in itself or the connection unless busway branch circuit supplies protection. Branches have their own overcurrent devices. Overcurrent unit for parts not readily accessible is guarded or enclosed until disconnected from supply. Busway overcurrent protection conforms to current capacity except, (1) if not standard rating, next larger device may be used if not over 150% of busway capacity, (2) may omit protection at branch busways of reduced size if branch rating at least  $\frac{1}{3}$  that of protection next back on line, and busway not in contact with combustible material.

Recommendations are in general the same as for wireways with reference to supports, extensions through walls, and dead-ends.

## CABLE ASSEMBLIES

**To Be Continuous.** All cable assemblies used for interior wiring shall be continuous from outlet to outlet and from fitting to fitting, and shall be mechanically secured to boxes and fittings except as provided for non-metallic outlet boxes.

**Securely Mounted.** Cable assemblies shall be securely fastened in place.

**ARMORED CABLE.** Contains two or more individually insulated conductors, wrapped together with an insulating cover and enclosed within an interlocking spirally wound galvanized steel cover to form a flexible cable assembly. Type ACL lead-sheathed armored cable has a continuous lead tubing or sheath

## WIRING METHODS AND MATERIALS

between the spiral steel outer cover and the conductors.

**Use.** Armored cable (types AC and ACV) may be used for exposed or concealed work in dry locations; for underplaster extensions as provided; and embedded in plaster finish on brick or other masonry, except in damp or wet locations. Armored cable shall contain lead-covered conductors (type ACL) if used where exposed to the weather or to continuous moisture, for underground runs and embedded in masonry, concrete or fill in buildings in course of construction, and where exposed to oil, gasoline or other materials having a deteriorating effect on rubber. Armored cable shall not be used (1) in theaters; (2) in motion-picture studios; (3) in any hazardous locations; (4) where exposed to corrosive fumes or vapors; (5) in storage-battery rooms; (6) on cranes or hoists, except as provided; nor (7) in hoistways or on elevators, except as provided.

**Supports.** Armored cable shall be secured by approved staples, straps, or similar fittings, so designed and installed as not to injure the cable. Cable shall be secured at intervals not exceeding  $4\frac{1}{2}$  feet and within 12 inches from every outlet box or fitting, except where cable is fished and except lengths of not over 24 inches at terminals where flexibility is necessary.

**Exposed Work.** Exposed runs of cable shall closely follow the surface of the building finish or of running boards, except:

- a. Lengths of not more than 24 inches at terminals where flexibility is necessary.
- b. In accessible attics and roof spaces, for which see the following paragraph.
- c. On the underside of floor joists in basements where supported at each joist and so located as not to be subject to mechanical injury.

**In Accessible Attics.** Cable in accessible attics or roof spaces shall be installed as follows:

- a. If run across the top of floor joists, or within 7 feet of floor or floor joist across the face of rafters or studding, the cable shall be protected by substantial guard strips which are at least as high as the cable. If the attic is not accessible by permanent stairs or ladders, protection will only be required within 6 feet of the nearest edge of scuttle hole or attic entrance.
- b. If carried along the sides of rafters, studs or floor joists, neither guard strips, nor running boards shall be required.

**Protection at Cable Ends.** At all points where the armor terminates, a fitting shall be provided to protect wires from abrasion, unless the design of the

## WIRING METHODS AND MATERIALS

outlet boxes or fittings is such as to afford equivalent protection, and in addition, an approved insulating bushing or its equivalent approved protection shall be provided between the conductors and the armor. The connector or clamp by which the armored cable is fastened to boxes or cabinets shall be of such design that the insulating bushing or its equivalent will be visible for inspection. This bushing will not be required with lead-covered cables which shall be so installed that the lead sheath will be visible for inspection.

**Bends.** All bends shall be so made that the armor of the cable will not be injured, and the radius of the curve of the inner edge of any bend shall be not less than 5 times the diameter of the cable.

**NON-METALLIC SHEATHED CABLE.** Consists of two or three individually insulated conductors, and sometimes of an additional uninsulated grounding conductor, with the assembly enclosed and protected by heavy cotton braid.

**Use.** Non-metallic sheathed cable may be used for both exposed and concealed work. Non-metallic sheathed cable shall not be embedded in masonry, concrete, fill, or plaster. It shall not be installed (1) in commercial garages, (2) in theaters, (3) in motion-picture studios, (4) in storage-battery rooms, (5) in hoistways, (6) in any hazardous location; nor (7) in breweries, ice plants, cold storage warehouses, and similar wet locations where subject to mildly corrosive fumes and vapors, but not including dairy barns, chicken houses and similar locations.

**Exposed Work—General.** In exposed work, with some exceptions, the cable shall be installed as follows:

a. The cable shall closely follow the surface of the building finish or of running boards.

b. It shall be protected from mechanical injury where necessary, by conduit, pipe, guard strips or other means. If passing through a floor the cable shall be enclosed in rigid conduit or pipe extending at least 6 inches above the floor.

**In Unfinished Basements.** If the cable is run at angles with joists in unfinished basements, assemblies not smaller than two No. 6 or three No. 8 conductors may be secured directly to the lower edges of the joists; smaller assemblies shall either be run through bored holes in the joists or on running boards. Where run parallel to joists, cable of any size shall be secured to the sides or face of the joists.

**Devices of Insulating Material.** Switch, outlet and tap devices of insulating material may be used without boxes in exposed cable wiring. Openings in such devices shall form a close fit around the outer covering

## WIRING METHODS AND MATERIALS

of the cable and the device shall fully enclose that part of the cable from which any part of the covering has been removed. If connections to conductors are by binding-screw terminals, there shall be available as many screws as conductors, unless cables are clamped within the structure, or unless terminals are of a type approved for the purpose.

**Boxes of Insulating Material.** Non-metallic outlet boxes approved for the purpose may be used as provided by usual rules applying to such switches.

**Thermal Insulation.** If thermal insulation is used in the hollow spaces of walls and ceilings in which non-metallic sheathed cable is installed, only approved non-corrosive, non-combustible, non-conducting materials shall be used, and these shall be applied in a manner not liable to place a strain upon the cable, its supports, or terminal connections.

Recommendations are in general the same as for armored cable with reference to supports, bends, and use in accessible attics.

**SERVICE ENTRANCE CABLE.** Two or more individually insulated conductors wrapped together with kraft paper. An uninsulated grounding conductor may be formed by wire strands spiralled around the outside of the paper. Some types have additional steel armor. The whole assembly is enclosed within one or more layers of impregnated cotton braid.

**Use.** Approved service-entrance cable (Types SE and ASE) may be used in interior wiring systems if all the conductors of the cable are of the rubber-covered type; but if without individual insulation on the grounded conductor may be used only for range and domestic water-heater circuits, or as feeders from a master service cabinet to supply other buildings, or as service conductors for such other buildings, if the following conditions are met.

a. The cable has a final non-metallic outer covering.

b. The supply is alternating current not exceeding 150 volts to ground.

Metal-armored types of service entrance cable are handled in general like armored cable with reference to bends, exposed work, supports, and use in accessible attics. Other types of service entrance cable are handled in general like non-metallic sheathed cable.

### **NON-METALLIC SURFACE EXTENSIONS.**

Two individually insulated conductors mounted on fabric or other flexible support, or of two conductors in a single insulating flexible support, or of some equivalent arrangement designed for easy attachment to walls or other exposed building surfaces.

**Use.** Non-metallic surface extensions may be used only if all of the following conditions are met:

## WIRING METHODS AND MATERIALS

- a. The extensions are from existing outlets on branch circuits.
- b. The extensions are run exposed in dry locations.
- c. The building is occupied for residential or office purposes.
- d. The extensions are not in unfinished basements, attics, or roof spaces.
- e. The voltage does not exceed 150 volts between conductors.
- f. The extensions are not subject to corrosive vapors.

**Outlets Per Circuit.** The total number of outlets supplied by one branch circuit, including those previously installed and those of the extension, shall be in conformity with the requirements for standard branch circuits.

**Not to Run Outside Room.** An extension shall not be run through a floor or partition, nor outside the room in which it originates.

**Location in Room.** One or more extensions may be run in any direction from an existing outlet, but not on the floor or within 2 inches from the floor. An extension shall be attached only to woodwork or plaster finish, and shall not be in contact with any metal work or other conductive material except the metal plates on receptacles.

**Supports.** Non-metallic surface extensions shall be secured in place by approved means at intervals not exceeding 8 inches, except that where connection to the supplying outlet is made by means of an attachment plug the first fastening may be placed 12 inches or less from the plug. There shall be at least one fastening between each two adjacent outlets supplied.

**Splices and Taps.** Extensions shall consist of a continuous unbroken length of the assembly, without splices, and without exposed conductors between fittings. Taps may be made if fittings completely covering the tap connections are used.

**Bends.** A bend in an assembly which reduces the normal spacing between the conductors shall be covered with a cap to protect the assembly from mechanical injury.
























**Fittings.** Each run of an assembly shall terminate in a fitting which covers the end of the assembly. All fittings and devices shall be of a type approved for the purpose.

**NON-METALLIC WATERPROOF WIRING.** Consists of multiple-conductor rubber sheathed cable approved for the purpose. Individual conductors are not smaller than number 12, except that for equipment grounding purposes only, the cable may contain some other approved size of conductor with or without individual insulation.

# WIRING METHODS AND MATERIALS

## WIRING SYMBOLS
























### ELECTRICAL EQUIPMENT OF BUILDINGS

Ceiling Outlet		Automatic Door Switch	$S^D$
Ceiling Fan Outlet		Key Push Button Switch	$S^K$
Floor Outlet		Electrolier Switch	$S^E$
Drop Cord		Push Button Switch and Pilot	$S^P$
Wall Bracket		Remote Control Push Button	$S^R$
Wall Fan Outlet		Motor	
Single Convenience Outlet		Motor Controller	
Double Convenience Outlet		Lighting Panel	
Junction Box		Power Panel	
Special Purpose Outlet-Lighting, Heating and Power as Described in Specification		Heating Panel	
Special Purpose Outlet-Lighting, Heating and Power as Described in Specification		Pull Box	
Special Purpose Outlet-Lighting, Heating and Power as Described in Specification		Cable Supporting Box	
Exit light		Meter	
Pull Switch		Transformer	
Local Switch-Single Pole	$S^1$		
Local Switch-Double Pole	$S^2$	Local Switch-4 Way	$S^4$
Local Switch-3 Way	$S^3$	This Character Marked on Top Circuits Indicates 2 No 14 Conductors in 1/2-in. Conduit	$\parallel$

# WIRING METHODS AND MATERIALS

## WIRING SYMBOLS

### ELECTRICAL EQUIPMENT OF BUILDINGS

Branch Circuit, Run concealed under Floor Above 	Local Fire Alarm Gong 
Branch Circuit, Run Exposed 	Local Fire Alarm Station 
Branch Circuit, Run concealed under Floor 	Fire Alarm Central Station 
Feeder, Run concealed under Floor Above 	Speaking Tube 
3 No 14 Conductors in 1/2 in. Conduit 	Nurses Signal Plug 
Feeder Run Exposed 	Maid's Plug 
Feeder, Run concealed under Floor 	Horn Outlet 
Pole-Line 	Clock (Secondary) 
Push Button 	Electric Door Opener 
Annunciator 	Watchman Station 
Interior Telephone 	4 No 14 Conductors in 3/4 in. Conduit Unless Marked 1/2 in. 
Public Telephone 	

**Use.** Subject to the approval of the authority enforcing this code, non-metallic waterproof wiring may be used for exposed work in breweries, ice plants, cold storage warehouses or similar wet locations where subject to mildly corrosive fumes and vapors, if the voltage does not exceed 300 volts between conductors or 150 volts to ground.

**Supports.** The cable shall be supported on insulators approved for the purpose and spaced at intervals not exceeding 3 feet.

**Attachment to Fittings.** The cable shall be securely fastened to all outlet boxes, fittings and cabinets. A moisture-proof seal shall be provided between the cable and all outlet boxes, fittings and cabinets.

**Passing Through Walls.** The cable shall be enclosed in rigid conduit, electrical metallic tubing, or ap-



# WIRING METHODS AND MATERIALS

## WIRING SYMBOLS INDUSTRIAL TYPES

Industry Standard of National Machine Tool Builders' Association

### CONDUCTORS AND TERMINALS

CONTROL CONDUCTOR	POWER CONDUCTOR	CONDUCTOR CROSSING	CONDUCTOR SPLICES	MULTI-CONDUCTOR WIRE	CONDUCTOR GROUP	TERMINAL OR STUD	CONTROL TERMINAL MARKING	TERMINAL MARKING	CONTROL CONDUCTOR (REVERSE)	CONDUCTOR (REVERSE)
—	—	— / —	— + —	— 1 —	— 1 2 3 —	○	6 8	8 etc.	— (—)	— (—)
LIGHT LINE	HEAVY LINE									

### MISCELLANEOUS

DISCONNECT DEVICE (PLUG OR COUPLING)	TEST JACK	METER	INDICATING LAMP	BELL	METER SHUNT	BATTERY	GROUND	FUSE	BRUSH AND SLIP RING	TIMER MOTOR

### RESISTORS AND CAPACITORS

FIXED	ADJUSTABLE	TAPPED	CONFORMING RESISTOR	PRESISTAT	POTENTIOMETER	CAPACITOR FIXED	DRY OR ELECTROLYTIC RECTIFIER	HALF WAVE	FULL WAVE

### COILS

SHUNT	SERIES	THERMAL	SOLENOID	REACTOR OR INDUCTOR					
				NON-MAGNETIC CORE			MAGNETIC CORE		
				FIXED	ADJUSTABLE	TAPPED	FIXED	ADJUSTABLE	TAPPED

### TRANSFORMERS

MAGNETIC CLUTCH	TRANSFORMERS			
	SINGLE PHASE TWO WINDINGS	CURRENT	AUTO TRANS.	TAPPED

### KNIFE SWITCHES AND CIRCUIT BREAKERS

MANUAL SWITCH	THERMAL TRIP BREAKER	AIR CIRCUIT BREAKER	OIL CIRCUIT BREAKER
SINGLE POLE	SINGLE POLE	SINGLE POLE	SINGLE THROW
MULTI POLE	MULTI POLE	MULTI POLE	DOUBLE THROW

### CONTROL DEVICES

PUSH BUTTONS						SELECTOR SWITCH																				
N.O.	N.C.	N.O.	N.C.	N.C.	DOUBLE CIRCUIT	N.O.	N.C.	N.O.	N.C.	TYPICAL TARGET																
										<table border="1" style="font-size: small;"> <tr> <td>POS</td> <td>SOLE</td> <td></td> <td></td> </tr> <tr> <td>A</td> <td>B</td> <td></td> <td></td> </tr> <tr> <td>AUTO</td> <td>X</td> <td>O</td> <td>/</td> </tr> <tr> <td>HAND</td> <td>O</td> <td>X</td> <td>/</td> </tr> </table>	POS	SOLE			A	B			AUTO	X	O	/	HAND	O	X	/
POS	SOLE																									
A	B																									
AUTO	X	O	/																							
HAND	O	X	/																							
MERCURY SWITCH		LIMIT SWITCHES				PRESSURE OR FLUID SWITCH		FLOAT SWITCH		PLUGGING (ZERO SPEED OR POSITION) SWITCH																
N.O.	N.C.	N.O.	N.C.	N.O.	N.C.	N.O.	N.C.	N.O.	N.C.																	

# WIRING METHODS AND MATERIALS

## WIRING SYMBOLS INDUSTRIAL TYPES

CONTACTORS									
MAIN CIRCUIT CONTACTS				CONTROL CIRCUIT CONTACTS		TIMING RELAY CONTACTS			
INSTANTANEOUS OPERATION				CONTACTS		ACTION DEFERRED WHEN COIL IS			
WITH BLOWOUT		WITHOUT BLOWOUT		NO	NC	ENERGIZED		DE-ENERGIZED	
NO	NC	NO	NC	NO	NC	NO	NC	NO	NC
OVERLOAD RELAY CONTACTS					MECHANICAL CONNECTIONS				
THERMAL		MAGNETIC			CONNECTION OR SHIELD		FULLERUM		
NC	NO	DASH POT (DELAYED TRIP)	NO	NC	NO	NC	INTERLOCK		

ALTERNATING AND DIRECT CURRENT MOTORS AND GENERATORS			
ALTERNATING CURRENT MOTORS			
SQUIRREL CAGE INDUCTION MOTOR OR GENERATOR	WOUND ROTOR INDUCTION MOTOR	SYNCHRONOUS MOTOR OR GENERATOR	
DIRECT CURRENT MOTORS			
PARTS OF D C MACHINES			
ARMATURE	COMMUTATING FIELD	SERIES FIELD	SHUNT FIELD
DC MOTOR OR GENERATOR WITH SERIES, SHUNT AND COMMUTATING WINDINGS		DC SHUNT MOTOR OR GENERATOR	DC SERIES MOTOR OR GENERATOR

proved insulating tubing, where passing through walls, and where so enclosed, the enclosure shall be sealed with a suitable fitting.

**Protection.** Where exposed to mechanical injury the cable shall be protected.

**Boxes and Fittings.** Boxes and fittings shall conform to the following:

a. Outlet boxes, fittings and cabinets shall be constructed of cast metal, insulating material or other material approved for the purpose.

b. Switch plates, fixtures, and similar parts shall be of insulating material when mounted on boxes, fittings, and cabinets of insulating material.

**Grounding.** Metal boxes, fittings, or cabinets if used shall be grounded in accordance with rules for grounding.

## WIRING METHODS AND MATERIALS

### WIRE SPLICING

The first very important step in making any splice is to properly strip and prepare the ends of the wire. Stripping means removing the insulation from the wire a proper distance back for the splice to be made. This may range from  $1\frac{1}{2}$  inches to 3 or 4 inches for various splices.

The rubber and braid should be removed with a knife, as shown in the upper view in Fig. 6-1. The knife and wire should be held in a position similar to that used when sharpening a pencil, and the braid and rubber cut through at an angle as shown. Be very careful not to cut or nick the wire, as it reduces the conducting area, and makes it very easy to break at that point.

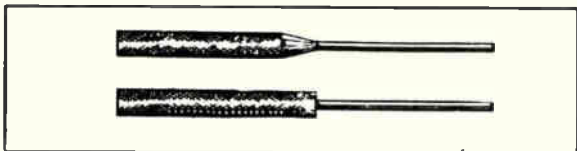


Fig. 6-1. This sketch shows the proper method of stripping the insulation from a wire in the upper view. The lower view shows the wrong way.

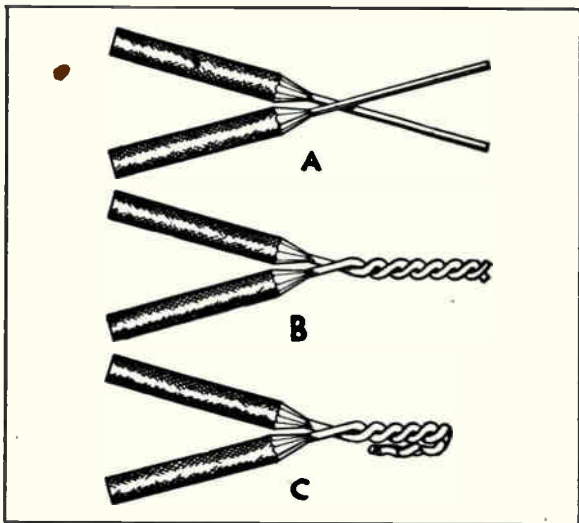


Fig. 6-2. This diagram shows very clearly the several steps in making a "Pigtail" splice.

## WIRING METHODS AND MATERIALS

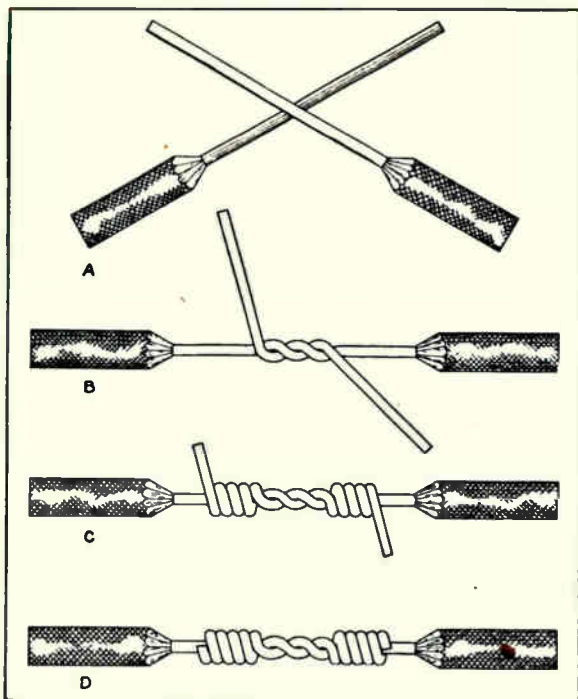


Fig. 6-3. The above four sketches show the steps and procedure in making a "Western Union" splice.

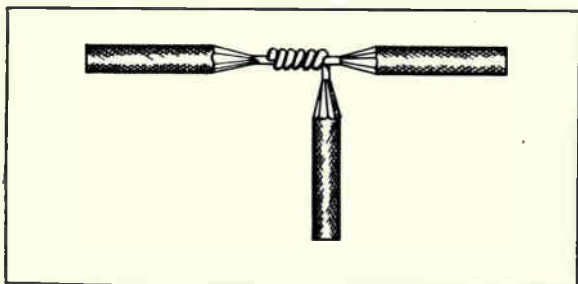


Fig. 6-4. Simple "Tap" splice used for tapping a "branch" wire to "main" or "running" wires.

## WIRING METHODS AND MATERIALS

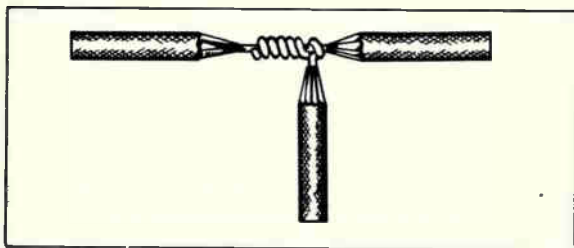


Fig. 6-5. "Knotted Tap" splice. Note carefully the manner in which the wire is first looped around the branch conductor to lock it securely in place.

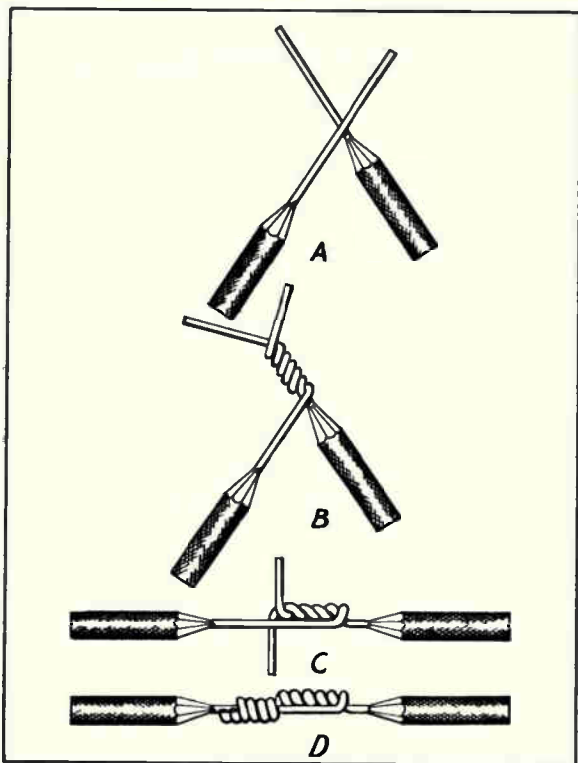


Fig. 6-6. The above views show the method of making a "Fixture" splice, which is used for connecting together two wires of different sizes.

# WIRING METHODS AND MATERIALS

## WIRE SPLICING

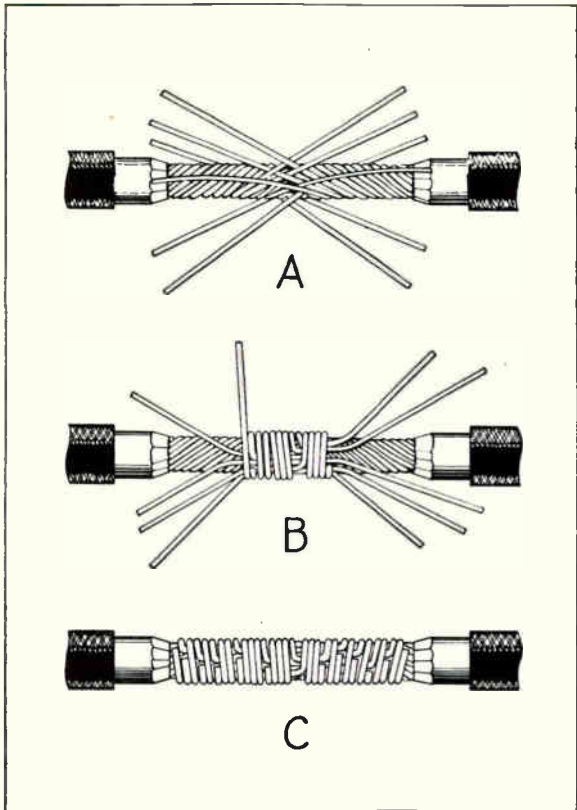


Fig. 6-7. A neat and efficient cable splice.

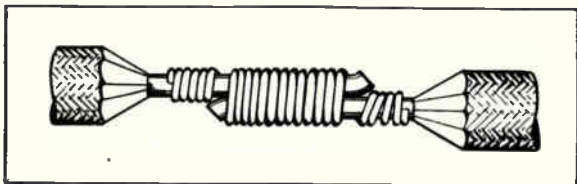


Fig. 6-8. A very convenient splice to use on large solid conductors. By wrapping them in this manner with the smaller wire we don't have to bend or twist the stiff heavy wires.

## WIRING METHODS AND MATERIALS

### WIRE SPLICING

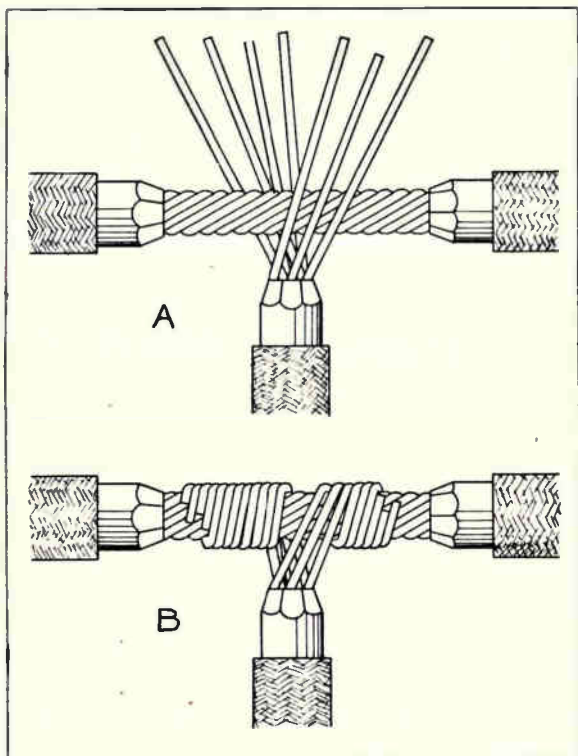


Fig. 69. Method of making a "tap" splice with stranded cables. Note how the wires of the "tap" cable are divided and each group wrapped in opposite directions around the "running" cable.

### SOLDERING SPLICES

All splices made in permanent wiring should be carefully soldered, to preserve the quality and conductivity of the splice.

We have already mentioned that altho soldering does improve the strength and conductivity of a splice to some extent, the main reason for soldering is to prevent corrosion or oxidization from spoiling the good contact of the wires.

## WIRING METHODS AND MATERIALS

### WIRE SPLICING

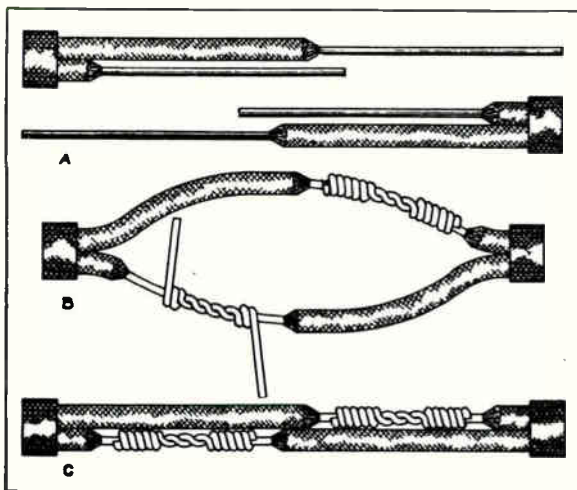


Fig. 6-10. When making splices in pairs of conductors they should be staggered as shown above so each splice will be near to good insulation on the other wire.

## WIRE CONNECTORS

### SOLDERLESS PRESSURE TYPES

- CC-B Butt type two-way cable connector. Fig. 6-11
- CC-L Elbow type two-way cable connector. Fig. 6-12
- CC-T Tee type three-way cable connector. Fig. 6-13
- CT-T Tee type cable tap. Fig. 6-14
- CT-P Parallel gutter type cable tap. Fig. 6-15.
- CL-1 One hole cable lug. Fig. 6-16
- CL-2 Two hole cable lug. Fig. 6-17

The above types accommodate wires from number 14 up to 2,000,000 circular mil sizes.

WC-N Nut type wire connector. In styles for fixtures and for universal use. Wires numbers 18 to 12. Fig. 6-18.

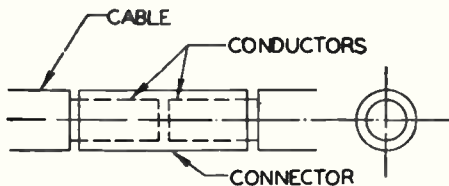


Fig. 6-11



# WIRING METHODS AND MATERIALS

## WIRE CONNECTORS

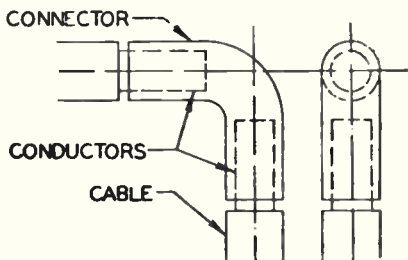


Fig. 6-12

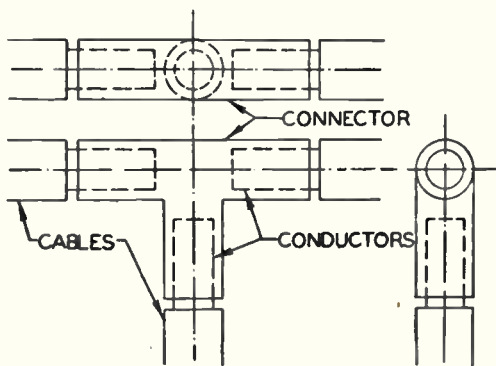


Fig. 6-13

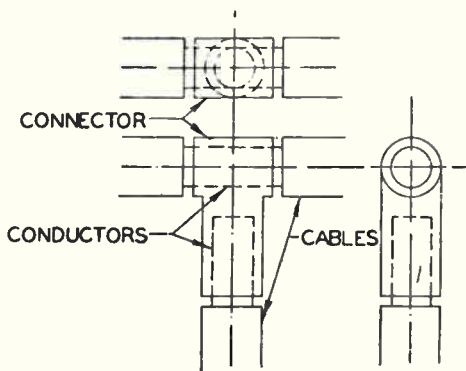


Fig. 6-14

WIRING METHODS AND MATERIALS  
WIRE CONNECTORS

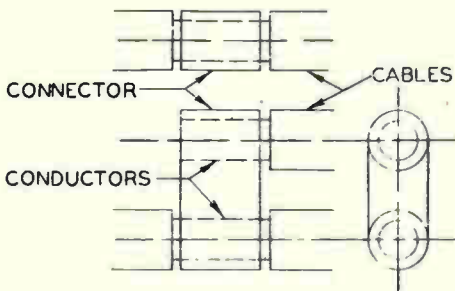


Fig. 6-15

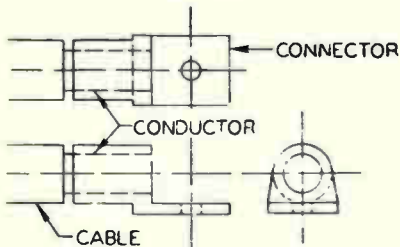


Fig. 6-16

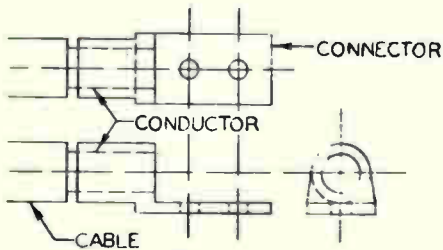


Fig. 6-17

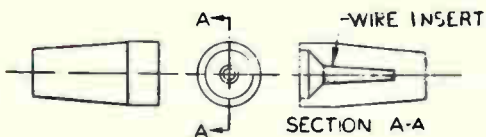


Fig. 6-18

# WIRING METHODS AND MATERIALS

## SWITCH CONNECTIONS FOR LIGHTING

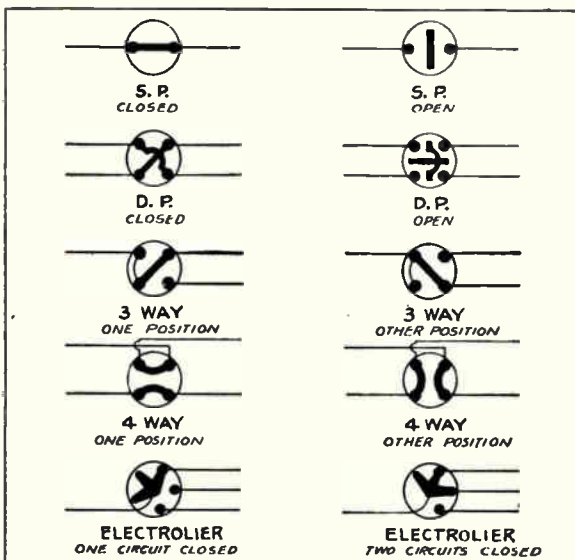


Fig. 6-19. The above symbols will be used to represent various types of switches in the following connection diagrams.

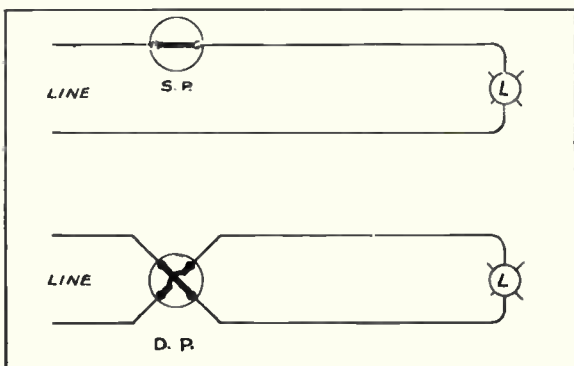
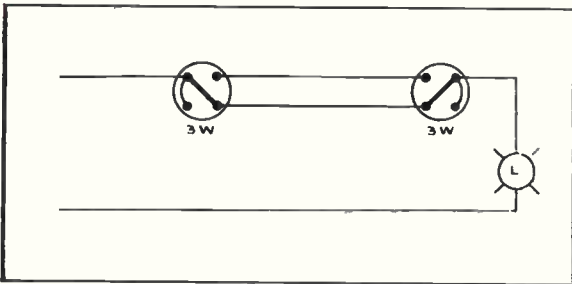
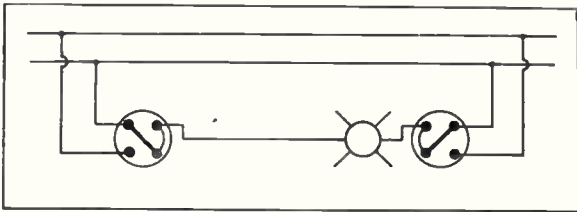


Fig. 6-20. The top diagram shows a simple single-pole switch connected to control one light. The lower diagram shows a double-pole switch connected to break both sides of the circuit to a light.

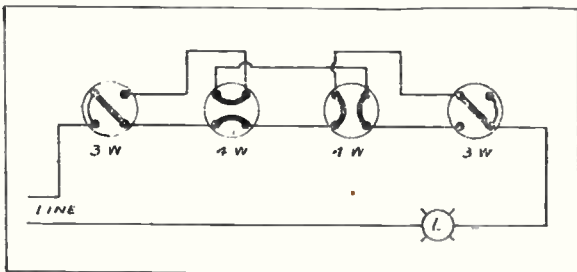
## WIRING METHODS AND MATERIALS



**Fig. 6-21.** Two three-way switches used for controlling a light from two different places.



**Fig. 6-22.** This sketch shows the Cartweis system of connecting three-way switches. This method should not be used on 110-volt circuits in interior wiring.



**Fig. 6-23.** This diagram shows two three-way and two four-way switches connected to control a light from four different places. Note carefully the connection and arrangement of the three-way switches at the ends, and the manner in which the wires to one side of the four-way switches are crossed.

## WIRING METHODS AND MATERIALS

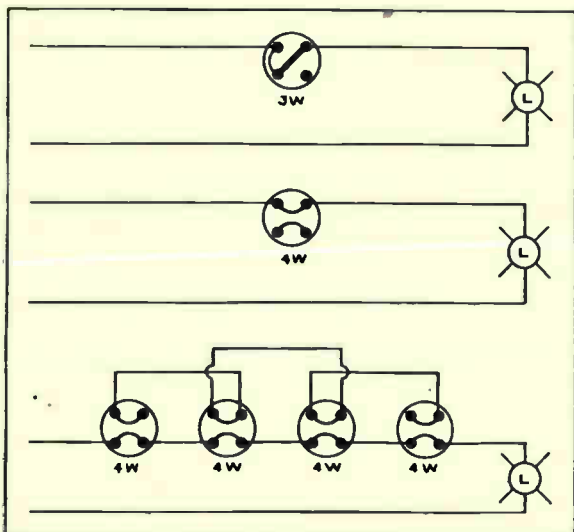


Fig. 6-24. The above three diagrams show methods of substituting various switches when the proper ones are not available. The top and center connections show the use of three-way and four-way switches in place of single-pole switches. The lower connection shows four-way switches used in place of three-way switches at the ends of the group.

### BRANCH CIRCUITS

Adapted from National Electrical Code

A branch circuit includes the portion of the wiring system extending beyond the final overcurrent device (fuse, cutout or circuit breaker) that protects the branch circuit. A thermal cutout or a motor overload protective device is not considered to be a circuit-protecting overcurrent device.

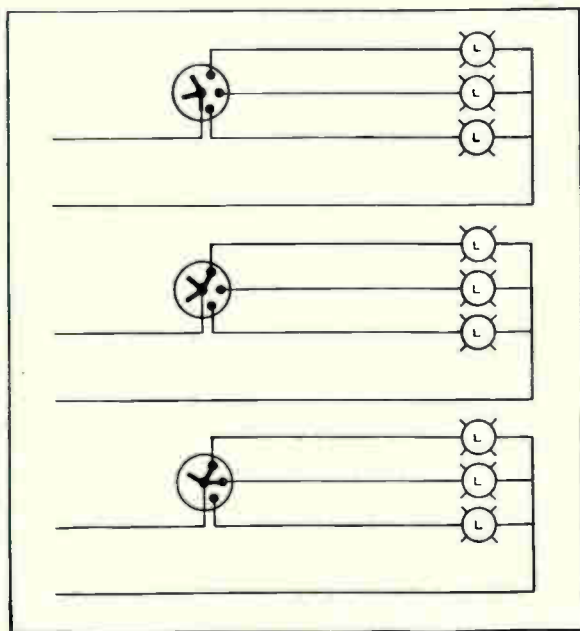
**Voltage.** Branch circuits supplying lampholders, fixtures or receptacles of the standard 15-ampere or less rating, shall not exceed 150 volts to ground, except as permitted for railway properties. In dwelling occupancies, the voltage between conductors supplying lampholders of the screw-shell type, receptacles, or appliances, shall not exceed 150 volts, except that the voltage between conductors supplying permanently connected appliances or portable appliances of more

## WIRING METHODS AND MATERIALS

than 1650 watts may exceed 150 volts if connected to receptacles of such design that attachment plugs used on circuits of other voltages cannot be inserted in them.

**Taps.** Taps to individual lampholders or fixtures, and taps not over 18 inches long to individual outlets supplying lampholders or fixtures, may be of smaller size than the branch-circuit conductor, but not less than the size of tap specified for each type of branch circuit, provided the load does not exceed the carrying capacity of the conductor.

**Determination of Circuits.** The minimum number of branch circuits shall be determined from the total load as computed below and the types of circuits to be used, but the number of branch circuits shall in every case be sufficient for the specific load to be served. The total load shall be evenly proportioned among the branch circuits according to the capacity of the circuits, insofar as practicable. If circuits sup-



**Fig. 6-25.** These three diagrams show the manner in which an electrolier switch can be used to turn on one or more lights at a time.

# WIRING METHODS AND MATERIALS

## SIGNAL AND ALARM CIRCUITS

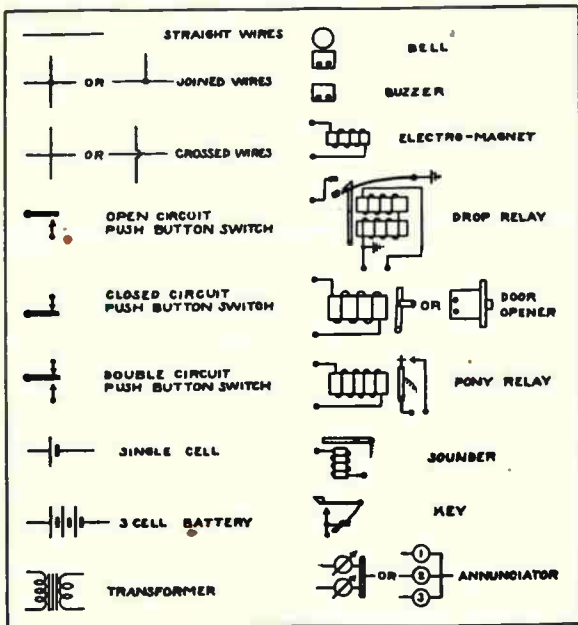


Fig. 6-26. These are some of the most important symbols used in signal diagrams and circuits.

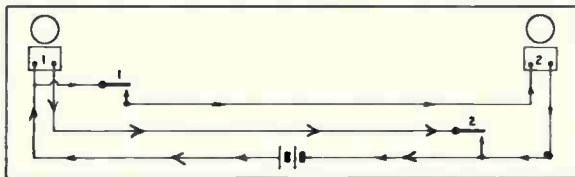
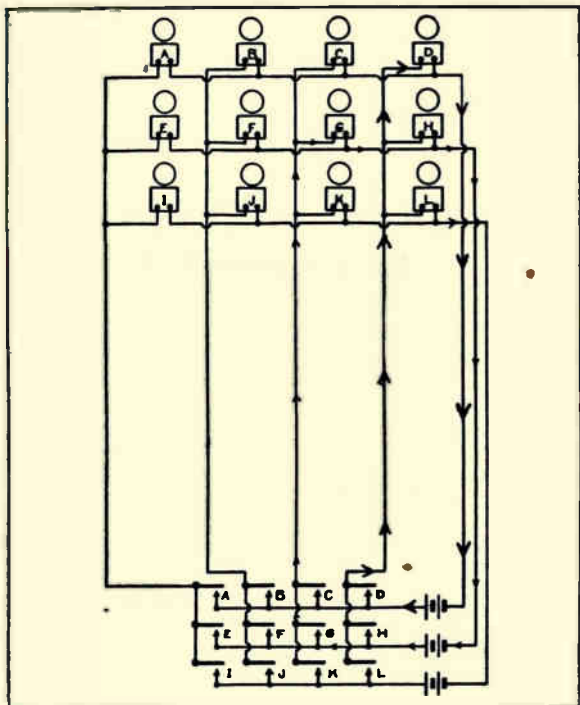
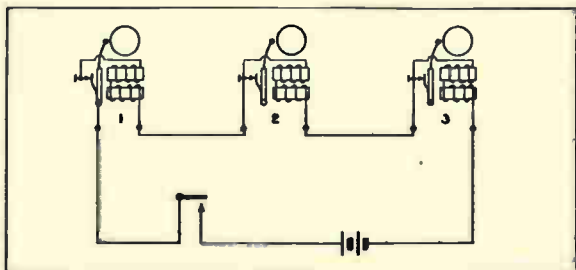


Fig. 6-27. Return call system. Button No. 1 will ring bell No. 2; button No. 2 rings bell No. 1.

## WIRING METHODS AND MATERIALS



**Fig. 6-28.** "Group" method of connecting a large number of bells and switches to secure independent operation of each with the least number of wires.



**Fig. 6-29.** This sketch shows the proper method of connecting vibrating bells in series to secure best results.



## WIRING METHODS AND MATERIALS

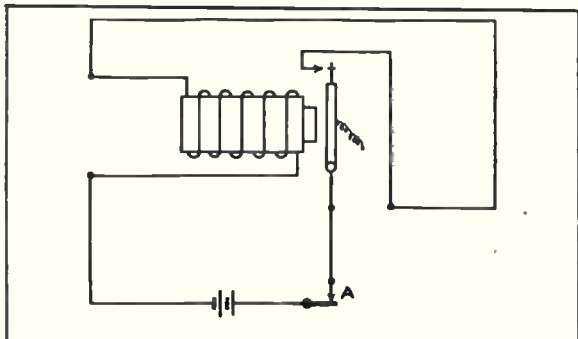


Fig. 6-30. Diagram illustrating the principle of a closed circuit stick relay.

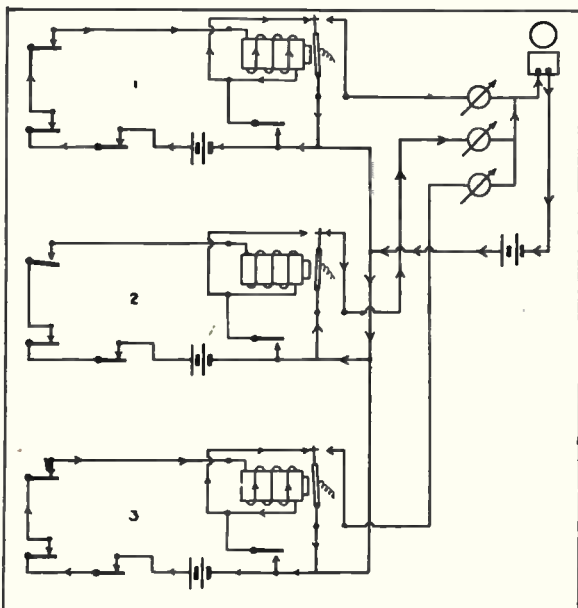


Fig. 6-31. Closed circuit burglar alarm system of three sections, each using stick relays for constant ringing; and an annunciator to indicate point of disturbance.

## WIRING METHODS AND MATERIALS

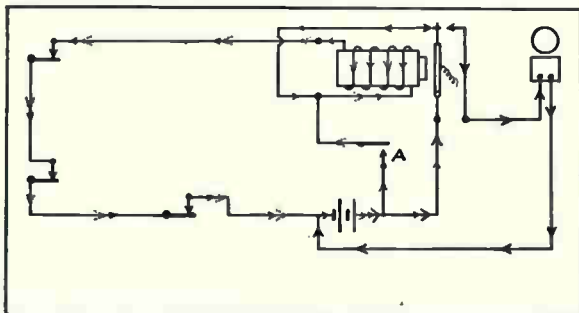
ply continuous loads, such as store lighting and similar loads, the load shall not exceed 80 per cent of the branch circuit rating.

**Calculation of Load.** In calculating the load on the basis of watts per square foot, the floor area shall be computed from the outside dimensions of the building, apartment, or area involved, and the number of floors, not including open porches, garages in connection with dwelling occupancies, nor unfinished spaces in basements or attics. The total computed load shall be the sum of the loads computed in accordance with the following:

a. **General Lighting.** For general illumination in the occupancies shown in the following table, a load of not less than the "watts per square foot" as specified for each occupancy shall be included for each square foot of floor area:

Occupancy	Watts per Square Foot
Apartments and Multi-Family Dwellings*....	2
Armories and Auditoriums .....	1
Banks .....	2
Churches .....	1
Clubs* .....	2
Dwellings, Single-Family*† .....	2
Hospitals .....	2
Hotels* .....	2
Office Buildings .....	2
Restaurants .....	2
Schools .....	3
Stores .....	3

In any of the above listed occupancies, except single-family dwellings and individual apartments of multi-family dwellings:



**Fig. 6-32.** Double circuit stick relay used in a closed circuit burglar alarm system. This is a very simple and efficient alarm circuit.

## WIRING METHODS AND MATERIALS

Assembly Halls and Auditoriums .....	1
Hallways, Corridors and Closets .....	$\frac{1}{2}$
Storage Spaces .....	$\frac{1}{4}$

\*It is recommended that in occupancies used for dwelling purposes, in addition to any branch circuit supplying appliances, a 15-ampere branch circuit be installed for each 500 square feet (approximately 3 watts per square foot) of floor area.

†In a single-family dwelling with a floor area of 500 square feet or less, the lighting load may be determined as specified under "Other Loads" below.

For general illumination in occupancies not listed above, the load shall be computed in accordance with the provisions under "Other Loads" below.

**b. Show-Window Lighting.** For show-window illumination, a load of not less than 200 watts shall be included for each linear foot of show-window, measured horizontally along its base.

**c. Small Appliances.** For small appliances, an additional load of not less than 1,500 watts shall be included for dining room, kitchen and laundry purposes in single-family dwellings, for individual apartments of multi-family dwellings having provisions for cooking by tenants, and in each hotel suite having a serving pantry; except that in single-family dwellings with a floor area of less than 1,000 square feet, the additional load may be 1,000 watts. For small appliances in other occupancies, see the following paragraph.

**d. Other Loads and Other Occupancies.** For other occupancies and for special lighting and appliance loads, capacity shall be included for the specific load to be served, but a load not less than specified below shall be included for each outlet:

Outlets supplying fixed appliances or special appliances .....	Amp. rating of appliance
Outlets supplying heavy-duty lampholders .....	5 amperes
Other outlets .....	$1\frac{1}{2}$ amperes

**Receptacle Circuits in Dwellings.** In dwelling occupancies, branch circuits, which supply receptacle outlets in kitchen, laundry, pantry, dining room, and breakfast room, shall not supply other outlets, and such circuits shall have conductors not smaller than No. 12.

**Receptacle Outlets.** Receptacle outlets shall be installed in every kitchen, dining room, breakfast room, living room, parlor, library, den, sun room, recreation room and bedroom. One receptacle outlet shall be provided for every 20 linear feet or major fraction thereof of the total (gross) distance around the room as measured horizontally along the wall at the floor line. The receptacle outlets shall, insofar as practicable, be spaced equal distances apart. At least one

## WIRING METHODS AND MATERIALS

receptacle outlet shall be installed for the connection of laundry appliances.

**Receptacles.** Receptacles shall conform to the following:

a. **Where Required.** Fixed receptacles shall be installed where portable cords are used, except where the attachment of flexible cords by other means is specifically permitted.

b. **Rating.** Receptacles shall have a rating of not less than the rating of the load served.

**Heavy-Duty Lampholders.** Heavy-duty lampholders include lampholders of the mogul type, a lampholder of the medium-base type which is an integral part of a single lighting unit having also a heavy-duty lampholder, and other lampholding devices required for lamps exceeding the maximum rating of the medium-base lamp.

**Classification.** Branch circuits recognized by this article shall be classified in accordance with the maximum permitted rating or setting of the overcurrent device as provided herein. When conductors of larger size than specified are used to provide for voltage drop, the specified rating or setting of the overcurrent device shall determine the circuit classification.

In each of the following circuits classified according to a number of amperes, overcurrent devices shall have a rating or setting not exceeding that number of amperes, and the maximum load shall not exceed that number of amperes which classifies each circuit.

### 15-Ampere Branch Circuit

**Conductors.** Conductors shall not be smaller than No. 14.

**Permissible Load.** A 15-ampere branch circuit may supply only:

a. **Lampholders.** Permanently connected lampholders of all types.

b. **Receptacles.** Receptacles rated at not more than 15 amperes supplying:

1. Lampholders of all types.

2. Appliances with individual rating of not more than 12 amperes.

c. **Fixed Appliances.** Fixed appliances with a total rating of not more than:

1. Six amperes, if the circuit also supplies lampholders or portable appliances.

2. Twelve amperes, if the circuit supplies motor-operated appliances.

3. Fifteen amperes, if the circuit supplies only fixed appliances other than motor-operated appliances.

## WIRING METHODS AND MATERIALS

### 20-Ampere Branch Circuit

**Conductors.** Conductors shall have a carrying-capacity of not less than 20 amperes, except that taps may be of No. 14.

**Permissible Load.** A 20-ampere circuit may supply only:

a. **Lampholders.** Permanently connected heavy-duty lampholders, or a medium-base lampholder of the porcelain keyless type which is part of a lighting unit connected directly with the permanent wiring and controlled by a switch.

b. **Receptacles.** Receptacles rated at not less than 15 amperes supplying:

1. Lampholders of heavy-duty type.

2. Appliances with individual rating of not more than 15 amperes.

c. **Fixed Appliances.** Fixed appliances with a total rating of not more than:

1. Fifteen amperes, if the circuit also supplies lampholders or portable appliances.

2. Fifteen amperes, if the circuit supplies motor-operated appliances.

3. Twenty amperes, if the circuit supplies only fixed appliances other than motor-operated appliances.

### 25-Ampere Branch Circuit

**Conductors.** Conductors shall have a carrying-capacity of not less than 25 amperes, except that taps may be of less capacity but not smaller than No. 14.

**Permissible Load.** A 25-ampere branch circuit may supply only:

a. **Lampholders.** Permanently connected heavy-duty lampholders.

b. **Receptacles.** Receptacles rated at not less than 20 amperes supplying:

1. Lampholders of heavy-duty type.

2. Appliances with individual rating of not more than 20 amperes.

c. **Fixed Appliances.** Fixed appliances with a total rating of not more than:

1. Twenty amperes, if the circuit also supplies lampholders or portable appliances.

2. Twenty amperes, if the circuit supplies motor-operated appliances.

3. Twenty-five amperes, if the circuit supplies only fixed appliances other than motor-operated appliances.

### 35-Ampere Branch Circuit

The 35-ampere branch circuit shall not be used in dwelling occupancies to supply lampholders, nor to supply portable appliances in any occupancy.

For portable appliances rated in excess of 20 amperes see "Individual Branch Circuits."

## WIRING METHODS AND MATERIALS

**Conductors.** Conductors shall have a carrying capacity of not less than 35 amperes, except that taps may be of less capacity but not smaller than No. 14.

**Permissible Load.** A 35-ampere branch circuit may supply only:

a. **Lampholders.** Permanently connected heavy-duty lampholders in other than dwelling occupancies.

b. **Receptacles.** Receptacles rated at not less than 30 amperes supplying:

1. Lampholders of the heavy-duty type in other than dwelling occupancies.

2. Appliances other than portable.

c. **Fixed Appliances.** Fixed appliances with a total rating of not more than:

1. Twenty-five amperes, if the circuit also supplies lampholders.

2. Twenty-five amperes, if the circuit also supplies motor-operated appliances.

3. Thirty-five amperes, if the circuit supplies only fixed appliances other than motor-operated appliances.

### 50-Ampere Branch Circuit

The 50-ampere branch circuit shall not be used to supply lampholders in dwelling occupancies, nor to supply portable appliances or combination lighting load and appliance load in any type occupancy.

For portable appliances rated in excess of 20 amperes see "Individual Branch Circuits."

**Conductors.** Conductors shall have a carrying capacity of not less than 50 amperes, except that taps may be of less capacity but not smaller than No. 12.

**Permissible Load.** A 50-ampere branch circuit may supply only:

a. **Lampholders.** Permanently connected heavy-duty lampholders in other than dwelling occupancies.

b. **Receptacles.** Receptacles rated at not less than 50 amperes supplying:

1. Lampholders of the heavy-duty type in other than dwelling occupancies.

2. Cooking appliances other than portable.

c. **Fixed Appliances.** A group of fixed cooking appliances, or a fixed range and water heater, with a total rating of not more than 50 amperes.

### Individual Branch Circuit

The individual branch circuit, except branch circuits supplying motors and motor-operated appliances, shall be used to supply only a single outlet or appliance.

**Conductors.** Conductors shall have a carrying capacity sufficient for the load which they supply.

**Overcurrent Protection.** Overcurrent devices shall have a rating or setting not in excess of the carrying capacity of the conductors of the circuit and not exceeding 150 per cent of the rating of the appliance.

## WIRING METHODS AND MATERIALS

**Maximum Load.** The load shall not be limited. If an individual branch circuit supplies a range, hot plate, or similar appliance with surface heating elements, having a rating of more than 70 amperes, the appliance shall have sub-divided circuits each provided with over-current protection not exceeding 50 amperes.

**Permissible Load.** An individual branch circuit may supply only:

a. **Lampholders.** A single lampholder or lighting fixture.

b. **Receptacles.** A receptacle supplying:

1. A single lampholder or lighting fixture.  
2. A single appliance of any rating, except as limited above.

c. **Fixed Appliances.** A single fixed appliance of any rating, except as limited above.

**Receptacle.** A device which holds or supports and at the same time makes electrical connections to a lampholder, lamp base, cord plug, or other attachment device.

**Receptacle Outlet.** An outlet equipped with one or more receptacles intended to receive attachment plugs or cord plugs, not with receptacles of the screw type.

**Lighting Outlet.** In a building wiring system an outlet intended for direct connection of a lampholder, a lighting fixture, or a cord that carries a lampholder.

## GROUNDING

**Two-Wire Direct-Current Systems.** Two-wire direct-current systems supplying interior wiring, and operating at not more than 300 volts between conductors, shall be grounded, unless such system is used for supplying industrial equipment in limited areas and the circuit is equipped with a ground detector.

It is recommended that 2-wire direct-current systems operating at more than 300 volts between conductors be grounded if a neutral point can be established such that the maximum difference of potential between the neutral point and any other point on the system does not exceed 300 volts. It is recommended that 2-wire direct-current systems be not grounded if the voltage to ground of either conductor would exceed 300 volts after grounding.

**Three-Wire Direct-Current Systems.** The neutral conductor of all 3-wire direct-current systems supplying interior wiring shall be grounded.

**Alternating-Current Systems.** Secondary alternating-current systems supplying interior wiring, and interior alternating-current wiring systems, shall be grounded if they can be so grounded that the maximum voltage to ground does not exceed 150 volts.

It is recommended that such systems be grounded as provided herein if the voltage to ground exceeds 150 volts, but does not exceed 300 volts. Higher voltage circuits may be grounded.

## WIRING METHODS AND MATERIALS

**Voltage to Ground.** In grounded circuits, the voltage between the given conductor and that point or conductor of the circuit which is grounded.

In ungrounded circuits, the greatest voltage between the given conductor and any other conductor of the circuit.

### TYPES OF LOCATIONS

**Dry Location:** A location not normally subject to dampness or wetness. A location classified as dry may be temporarily subject to dampness or wetness, as in the case of a building under construction.

**Damp Location:** A location subject to a moderate degree of moisture, such as some basements, some barns, some cold storage warehouses, and the like.

**Wet Location:** A location subject to saturation with water or other liquids, such as locations exposed to the weather, wash rooms in garages, and like locations. Installations underground or in concrete slabs or masonry in direct contact with the earth, shall be considered as wet locations.

**Hazardous Location:** Premises, locations, rooms or portions thereof in which (1) highly flammable gases, flammable volatile liquids, mixtures or other highly flammable substances are manufactured or used or are stored in other than original containers; or (2) where combustible dust or flyings are likely to be present in quantities sufficient to produce an explosive or combustible mixture; or (3) where it is impracticable to prevent such combustible dust from collecting in such quantities on or in motors, lamps or other electrical devices that they are likely to become overheated because normal radiation is prevented; or (4) where easily ignitable fibres or materials producing combustible flyings are handled, manufactured, stored or used.

### HIGH VOLTAGE TEST FOR WIRING INSTALLATIONS

The following method is recommended for installations on R.E.A. work in testing for polarity, short circuits, and accidental grounds.

As you will note in the accompanying diagram, the necessary equipment consists of one 220 volt Neon lamp, one 250 volt 25 watt incandescent lamp, a 220 volt DC supply and leads of sufficient length to connect supply to meter socket.

**Polarity Test.** When a Neon lamp is connected to a DC supply only one electrode will glow, the one connected to the negative line. To make this test screw the Neon lamp into the sockets to be tested. If the correct electrode glows the polarity is correct.



## WIRING METHODS AND MATERIALS

We suggest you test the Neon lamp on a known polarity and mark the electrode which should glow.

**Short Circuit and Ground Test.** In this test, remove all lamps and appliances, and close all switches. If the pilot lamp lights, it indicates a short or ground. To localize the offending circuit, first remove fuses in branch circuits, one at a time, until light is extinguished. When the branch circuit is located then open switches one at a time until a switch is opened which causes the light to go dark.

**Supply for Testing.** Possibly five 45 volt "B" batteries serve the purpose as well as anything. However, a Mallory Vibrapack No. V. P. 552 may be used in conjunction with your car battery. This is a vibrator power pack which connects to a six volt battery, supplying an output of 225 volts and up, and a 100 M.A. capacity. This Vibrapack may be purchased from any Radio supply house. If this unit is used, be sure to use a 250 volt 25 watt lamp.

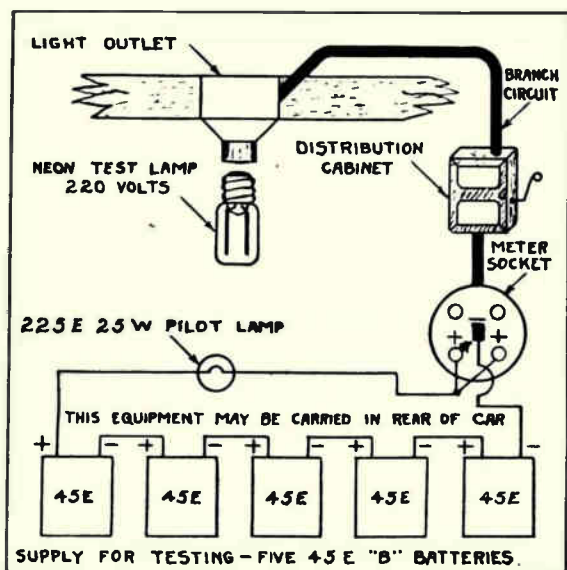


Fig. 6-33

**Insulation Resistance Tests.** The National Electrical Code states that all wiring shall be so installed that when completed the system will be free from short circuits and grounds. In order that a reasonable factor of safety may be provided, the following table

## WIRING METHODS AND MATERIALS

of insulation resistances is suggested by the Code as a guide where the insulation is subjected to test. Insulation testing methods are described in the section on Insulation and Insulators.

1. For circuits of No. 14 or No. 12 wire...1,000,000 ohms  
For circuits of No. 10 or larger conductor, a resistance based upon the allowable current-carrying capacity of conductors as fixed in Tables 1 and 2 of Chapter 10, of this code as follows:

25 to 50 amperes, inclusive.....	250,000 ohms
51 to 100 amperes, inclusive.....	100,000 ohms
101 to 200 amperes, inclusive.....	50,000 ohms
201 to 400 amperes, inclusive.....	25,000 ohms
401 to 800 amperes, inclusive.....	12,000 ohms
Over 800 amperes .....	5,000 ohms

2. The above values shall be determined with all switchboards, panelboards, fuseholders, switches and overcurrent devices in place.

3. If lampholders, receptacles, fixtures, or appliances are also connected, the minimum resistance permitted for branch circuits supplying same shall be one-half the values specified in paragraph 1.

4. Where climatic conditions are such that the wiring or equipment is exposed to excessive humidity, it may be necessary to modify the foregoing provisions.

### TROUBLE TESTS

When troubles such as grounds, opens or shorts occur in wires in conduit, the fault can be located as follows:

Suppose one wire is suspected of being broken or "open." Connect all the wire ends to the conduit at one end of the line, as in Fig. 6-34 at C. Then test with the bell and battery at the other end, from the conduit to each wire. The good wires will each cause the bell to ring, but No. 2, which is broken at "X" will not cause the bell to ring, unless its broken end happens to touch the conduit.

When testing for short-circuits between wires, disconnect all wires from the devices at each end of the line and test as in Fig. 6-34 at D.

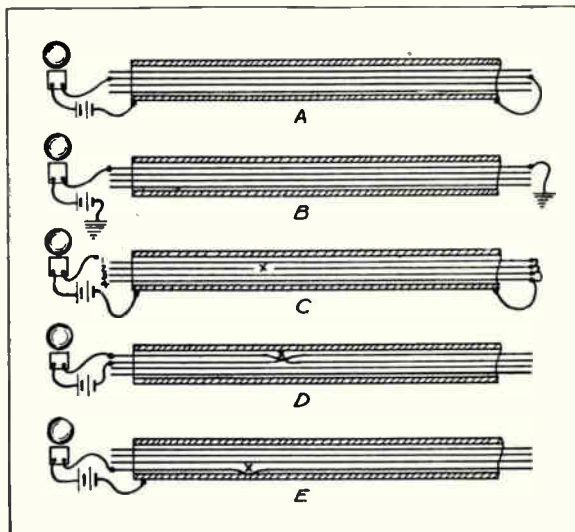
When the bell is connected to wires Nos. 1 and 2 it will ring, as they are shorted or touching each other at "X", through damaged insulation. Connecting the bell to any other pair will not cause it to ring.

Sometimes one wire becomes grounded to the conduit because of defective insulation as in Fig. 6-34 at E.

For this test we again disconnect the devices from the wires, and connect the test bell and battery as shown.

With one test lead on the conduit, try the other lead on each wire. It will not ring on Nos. 1, 2, or 3, but will ring on No. 4 which is touching the pipe at "X", thus making a closed circuit for the test bell.

## WIRING METHODS AND MATERIALS



**Fig. 6-34.** Sketches showing methods of testing for various faults in wires run in conduit.

## Section 7

# OVERCURRENT AND OVERLOAD PROTECTION

## DEFINITIONS

**Overcurrent Device.** A protective device, such as a fuse or circuit breaker, which acts almost instantaneously to open a circuit when current in that circuit exceeds a certain predetermined value.

**Fuse.** A strip or wire of metal which, when it carries an electric current greater than the capacity or rating of the fuse, will become so heated by the excess of current as to melt or burn out. The fuse is connected in the circuit to be protected against overcurrent, and melts to open the circuit when overcurrent exists in the circuit. A fuse sometimes is called a cutout. Other overcurrent protective devices include automatic relays and circuit breakers.

**Plug Fuse.** A fuse so mounted as to screw into its holder.

**Cartridge Fuse.** A fuse enclosed with an insulating and protective covering and provided with connections at its ends.

**Circuit Breaker.** A device for automatically opening a circuit in case of over-current in this or another circuit, and sometimes for opening the circuit in case of under-voltage.

**Overload Device.** A protective device, such as a thermally operated or heat-operated switch, that acts to open a circuit when an excessive load and excessive current have continued for long enough to bring temperature of the circuit wires nearly to the danger point.

**Time Delay Device.** A device such as a relay or circuit breaker that operates only after a period of time following some change of current or voltage, or some other action in an electrical system.

**Thermal Devices.** Devices such as relays and cut-outs that are operated usually by the expansion of parts which are heated by flow through them or through adjacent parts of an electric current. Excessive current causes excessive heating, and the expansion that operates the device. In other styles the overheating melts a fusible metal which releases the operating parts.

**Setting.** The current at which or in excess of which a circuit breaker or other adjustable protective device will operate to open its circuit.

## OVERCURRENT AND OVERLOAD

### PROTECTION

#### CIRCUIT BREAKERS AND FUSES

**Plug fuses** are used only in conductors between which the potential difference is no greater than 125 volts, except in wiring where there is a grounded neutral; but never are used where there is more than 150 volts to ground.

Plug fuses are used for currents not exceeding 30 amperes. These fuses for currents of 15 amperes and less are identified by having a hexagonal window, a hexagonally shaped top, or some other prominent hexagonal feature.

**Cartridge Fuses.** National Electrical Code standard cartridge enclosed fuses are made in two styles; the ferrule contact type and the knife blade contact type. Both are illustrated by Fig. 7-1.

Each type is made in various current ratings, but of each type there are only six sizes as classified by diameter and length. The current ratings in each size class are as follows:

0 - 30	101-200
31- 60	201-400
61 - 100	401-600

The fuses and fuse holders are so designed that it is impossible to put a fuse of any given class into a fuseholder which is designed for a lower current or a higher voltage than the class of the fuse itself. Each fuse is marked with its rating in amperes and volts.

In circuits whose currents exceed the greatest capacity of any standard cartridge fuse, fuses may be connected in multiple; using the fewest possible number of fuses of identical types and ratings, so connected that there is no difference of potential between terminals.

**Thermal devices** are not designed to open a circuit which is carrying the excessive current due to a short circuit or accidental ground, so must not be used for overcurrent protection of conductors.

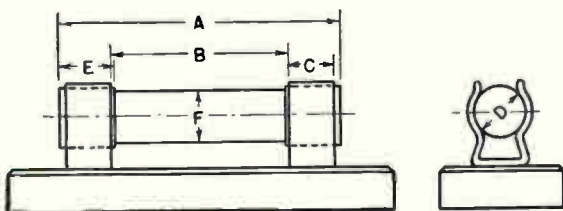
Time-delay, thermal-trip circuit breakers having fixed settings in amperes must not be rated at more than the allowable current-carrying capacity of the conductors in their circuit.

Thermal devices used for the running protection of motors must be protected by fuses or circuit breakers which have a capacity in amperes not over four times the rating of the motor, except in some circuits serving groups of motors.

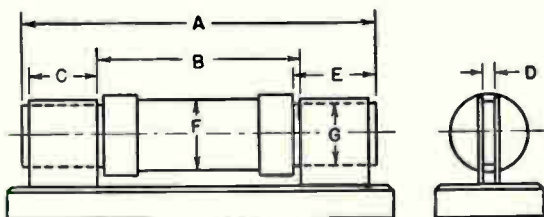
**Circuit breakers** are constructed so that they may be operated by hand as well as automatically. They always indicate whether their circuit is closed or open. Circuit breakers of the instantaneous type must be set to operate at a current no greater than 125 per

## OVERCURRENT AND OVERLOAD PROTECTION

cent of the current-carrying capacity of the conductors. This rule applies also to circuit breakers of the time-delay, magnetic trip type. Circuit breakers are intentionally constructed so that it is difficult to alter the setting.



Form 1. CARTRIDGE FUSE—Ferrule Contact.



Form 2. CARTRIDGE FUSE—Knife Blade Contact.

Fig. 7-1

### LOCATION OF OVERCURRENT DEVICES

Overcurrent devices which protect a given conductor ordinarily are located at the point where that conductor receives its current from another conductor or circuit. This rule does not apply where the overcurrent device protecting a larger conductor is of a rating which suitably protects the following smaller conductor. It does not apply either to service conductors, which receive their supply from an outside circuit, but in which the overcurrent device may be within the building.

Overcurrent devices for small installations always are mounted inside of enclosed cutout boxes or cabinets.

In circuits operating at more than 150 volts to ground, and generally in the case of cartridge fuses regardless of voltage, it must be possible to open the circuit containing an overcurrent device by a separate

## OVERCURRENT AND OVERLOAD PROTECTION

switch or other means, so that the overcurrent device will be dead when handled.

It is a general rule that every ungrounded conductor must run through an overcurrent device. A grounded

### SINGLE - PHASE

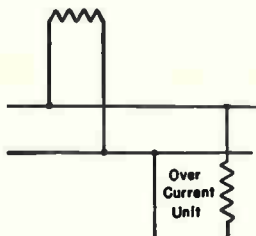


Fig. 7-2

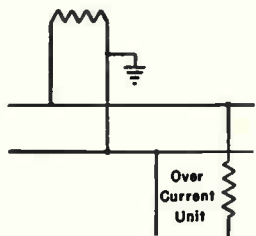


Fig. 7-3

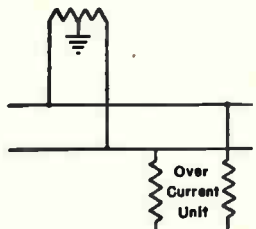


Fig. 7-4

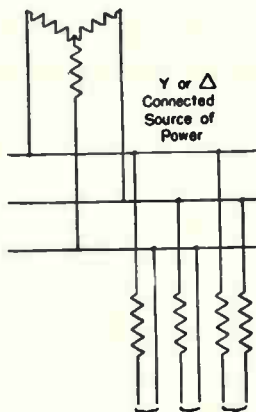


Fig. 7-5

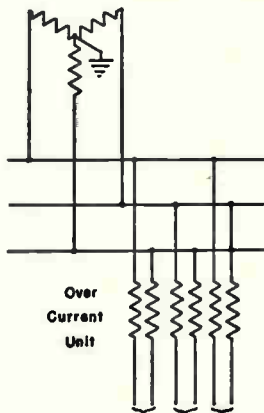


Fig. 7-6

conductor in the same circuit is assumed to be protected by the overcurrent device which is in the ungrounded conductor.

## OVERCURRENT AND OVERLOAD PROTECTION

In general there may be no overcurrent device in any permanently grounded conductor. However, there may be one when the same device simultaneously opens all grounded and ungrounded conductors of

### SINGLE AND TWO-PHASE

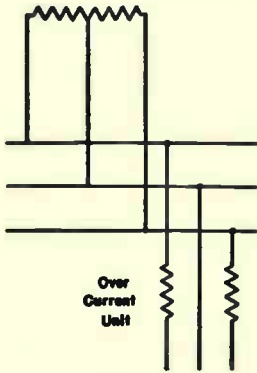


Fig. 7-7

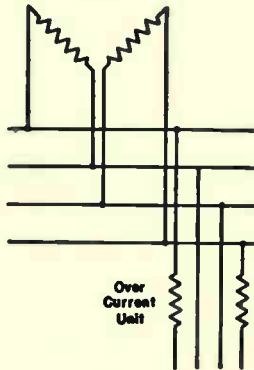


Fig. 7-9

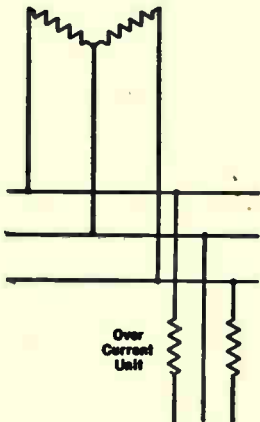
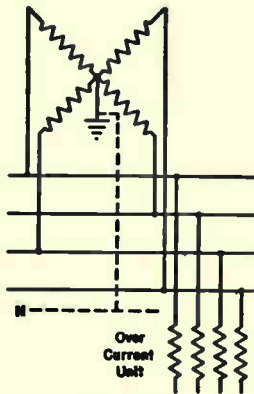


Fig. 7-8



Note - Neutral Grounded or Ungrounded for 2 Phase, 5 Wire System.

Fig. 7-10

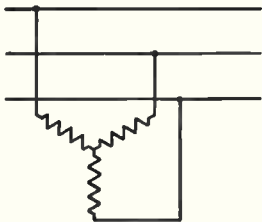
the circuit. There may be an overcurrent device in a grounded conductor when the circuit, of the 2-wire type, is of such type that it may have its connections reversed. Such a case is a 2-wire branch circuit in



## OVERCURRENT AND OVERLOAD PROTECTION

which the screw shells of all lampholders may not be connected to an identified grounded conductor. Then an overcurrent device should be in both conductors of this circuit.

### THREE-PHASE



Over Current Unit

Fig. 7-11

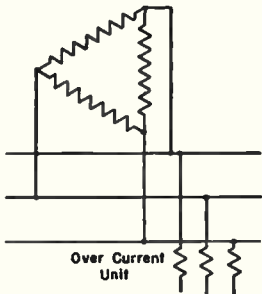
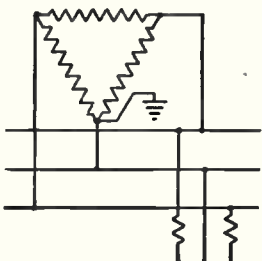


Fig. 7-12



Over Current Unit

Fig. 7-13

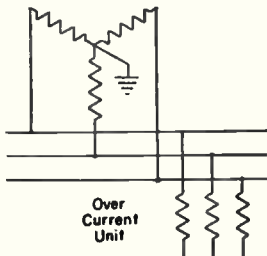
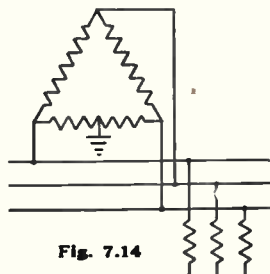


Fig. 7-14



Grounded or Ungrounded

Over Current Unit

Fig. 7-15

The following table and Figs. 7-2 to 7-15, from the National Electrical Code, shows the number of overcurrent devices, such as relays or trip coils, to be used for various kinds of circuits. This table does not apply to service conductors, nor to overcurrent protection for motors.

## OVERCURRENT AND OVERLOAD PROTECTION

When the table calls for three or four overcurrent devices, and such standard units are not available, it may be permissible to use two regular overcurrent devices and one or two extra fuses to make up the required number.

When a certain number of overcurrent devices is called for, all may be of the series type, or, instead of the series type, there may be the same number of current transformers and an equal number of secondary overcurrent tripping devices used with the transformers.

### RUNNING PROTECTION OF MOTORS

If fuses are used for the running protection of motors, one fuse is inserted in each ungrounded conductor. If other types of devices are used, such as relays, thermal cutouts or trip coils, the location of these devices and their minimum number are shown by the following table and in Fig. 7-16. If suitable devices are available, it is advisable to open all ungrounded conductors. In any case it is necessary to simultaneously open enough ungrounded conductors to interrupt flow of current to the motor. As an example, opening only one conductor of a 3-phase supply would allow current to continue through the two remaining conductors. Devices other than fuses must have a rating of at least 115 per cent of the full-load current of the motor.

Kind of Motor	Supply	Number & Location of Devices
1-phase A.C. or D.C.	2-wire, 1-phase A.C. or D.C., ungrounded	1 in either conductor
1-phase A.C. or D.C.	2-wire, 1-phase A.C. or D.C., one conductor grounded	1 in ungrounded conductor
1-phase A.C. or D.C.	3-wire, 1-phase A.C. or D.C., grounded-neutral	1 in either ungrounded conductor
2-phase A.C.	3-wire, 2-phase A.C., ungrounded	2, one in each phase
2-phase A.C.	3-wire, 2-phase A.C., one conductor grounded	2 in ungrounded conductors
2-phase A.C.	4-wire, 2-phase A.C., grounded or ungrounded	2, one per phase in ungrounded conductors
2-phase A.C.	5-wire, 2-phase A.C., grounded neutral or ungrounded	2, one per phase in any ungrounded phase wire
3-phase A.C.	3-wire, 3-phase A.C., ungrounded	2 in any 2 conductors
3-phase A.C.	3-wire, 3-phase A.C., one conductor grounded	2 in ungrounded conductors
3-phase A.C.	3-wire, 3-phase A.C., grounded-neutral	2 in any 2 conductors
3-phase A.C.	4-wire, 3-phase A.C., grounded-neutral or ungrounded	2 in any 2 conductors, except the neutral

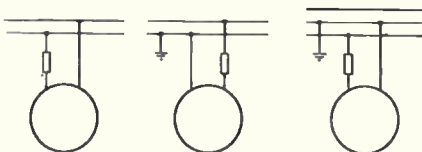
# OVERCURRENT AND OVERLOAD PROTECTION

## OVERCURRENT UNITS SUCH AS TRIP COILS OR RELAYS FOR PROTECTION OF CIRCUITS

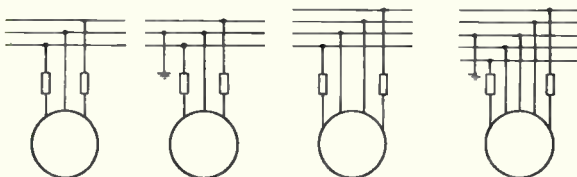
TYPE OF SYSTEM	NUMBER AND LOCATION OF DEVICES
2-Wire, Single-phase A.C. or D.C. Ungrounded.	One (in either conductor. Place always in conductors connected to same side of the circuit. Fig. 7-2)
2-Wire, Single-phase A.C. or D.C., One Wire Grounded.	One (in ungrounded conductor. Fig. 7-3)
2-Wire, Single-phase A.C. or D.C., Mid-point Grounded.	Two (one in each conductor. Fig. 7-4)
2-Wire, Single-phase A.C. Derived from 3-Phase, with Ungrounded Neutral.	Where a group of feeders is fed from the three phases of a common three-phase bus, each conductor served by either of two conductors of the three-phase bus must be equipped with one over-current unit. This will result in some circuits being equipped with one unit and other with two units. Fig. 7-5
2-Wire, Single-phase Derived from 3-Phase, Grounded Neutral System by Using outside Wires of 3-Phase Circuit.	Two (one in each conductor. Fig. 7-6)
3-Wire, Single-phase A.C. or D.C., Neutral Grounded or Ungrounded.	Two (one in each conductor except neutral conductor. Fig. 7-7)
3-Wire, 2-Phase, A.C., Common Wire Grounded or Ungrounded.	Two (one in each conductor except common conductor. Fig. 7-8)
4-Wire, 2-Phase, Ungrounded, Phases Separate.	Two (one in each phase. Place always in conductors connected to same side of the circuit in each phase. Fig. 7-9)
4-Wire, 2-Phase, Grounded Neutral, or 5-Wire, 2-Phase, Grounded or Ungrounded.	Four (one in each conductor except neutral conductor. Fig. 7-10)
3-Wire, 3-Phase, Ungrounded.	a. Three (one in each conductor if the circuit is served by a Y-delta or delta-Y transformer having the neutral in either case ungrounded or not connected to the circuit. Fig. 7-11). b. Two, under all other conditions. Place always in same phases.
3-Wire, 3-Phase, 1 Wire Grounded.	Two (one in each ungrounded conductor. Fig. 7-12)
3-Wire, 3-Phase, Grounded Neutral.	Three (one in each conductor. Fig. 7-13)
3-Wire, 3-Phase, Mid-point of one phase grounded	Three (one in each conductor. Fig. 7-14)
4-Wire, 3-Phase, Neutral Grounded or Ungrounded.	Three (one in each conductor except neutral conductor. Fig. 7-15)

# OVERCURRENT AND OVERLOAD PROTECTION

## SINGLE PHASE.



## TWO PHASE



## THREE PHASE.

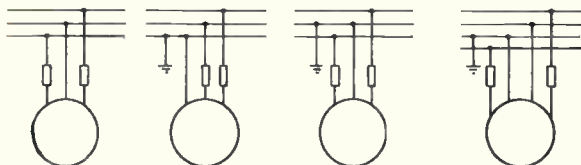


Fig. 7-16

## RATINGS OR SETTINGS OF MOTOR BRANCH CIRCUIT PROTECTIVE DEVICES

The following table gives settings or ratings for motor branch circuit protective devices as recommended by the National Electrical Code.

Where values specified do not correspond to standard sizes or ratings of fuses, circuit breakers, thermal cutouts, or thermal relays, or the heating elements of thermal-trip motor switches, the next larger size or rating may be used, but not exceeding 150 per cent of the full-load current rating of the motor.

Where the overcurrent protection specified in the table is not sufficient for the starting current of the motor it may be increased, but in no case may exceed four times the full-load running current of the motor.

Synchronous motors of the low-torque, low-speed type (usually 450 rpm or lower), such as are used to drive reciprocating compressors, pumps, etc., which

## OVERCURRENT AND OVERLOAD PROTECTION

start unloaded, do not require a fuse rating or circuit breaker setting in excess of 200 per cent of the motor full-load running current.

### MAXIMUM RATING OR SETTING OF MOTOR BRANCH CIRCUIT PROTECTIVE DEVICES

For Motors Not Marked With a Code Letter  
Indicating Locked Rotor KVA.

TYPE OF MOTOR	FUSE RATING	CIRCUIT BREAKER INSTAN- TANEOUS TYPE	TIME LIMIT TYPE
Single-phase, all types.....	300	---	250
Squirrel-cage and syn- chronous (full-voltage, resistor and reactor starting) _____	300	---	250
Squirrel-cage and syn- chronous (auto-trans- former starting)			
Not more than 30 am- peres _____	250	---	200
More than 30 amperes..	200	---	200
High-reactance squirrel-cage			
Not more than 30 am- peres _____	250	---	250
More than 30 amperes..	200	---	200
Wound-rotor _____	150	---	150
Direct-current			
Not more than 50 H.P.	150	250	150
More than 50 H.P.....	150	175	150

For Motors Marked With a Code Letter

All AC single-phase and polyphase squirrel cage and synchronous motors with full-voltage, resistor or reactor starting:			
Code Letter A _____	150	---	150
Code Letter B to E..	250	---	200
Code Letter F to R..	300	---	250
All AC squirrel cage and synchronous motors with auto-transformer starting:			
Code Letter A _____	150	---	150
Code Letter B to E..	200	---	200
Code Letter F to R..	250	---	200

## Section 8

# MAGNETS, COILS, AND INDUCTION

### DEFINITIONS

#### Permanent Magnets

**Magnet.** A piece of iron or steel which has the property of attracting other pieces of magnetic material such as iron, and has the property of attracting or repelling other magnets.

**Permanent Magnet.** A piece of steel in which the particles are so lined up that the piece remains magnetized and continues to have a magnetic field without help from any external magnetism.

**Pole.** One end of a magnet.

**Magnetic Polarity.** Identification of magnetic poles according to the direction of lines of force: the north pole being the one at which lines issue from the magnet, and the south pole the one at which they re-enter the magnet.

**Bipolar.** Having two magnetic poles, one north and the other south. Two-pole.

**Multipolar.** Having more than one magnetic pole. Usually refers to an electric machine having more than two poles, the two-pole types being called bipolar or two-pole.

**Compound Magnet.** A permanent magnet consisting of several similarly shaped single magnets in close contact and with like poles together.

**Retentivity.** A measure of the ability of a permanent magnet to retain its magnetic strength.

**Non-Magnetic.** Materials such as glass, wood, copper, brass and paper which are not affected by magnetic fields.

### COILS

**Helix.** A coil formed by a single-layer spiral winding, usually with no iron in the core-space.

**Coil.** A number of turns of wire wound on an iron core or on a coil form made of insulating material. A coil offers considerable opposition to the passage of alternating current but very little opposition to direct current.

**Core.** The center of a coil.

**Air Core.** A term used to describe coils or transformers which have no iron in their magnetic circuits. Air-core construction is used chiefly in high-frequency circuits.

**Electromagnet.** A coil of wire, usually wound on an iron core, which produces a strong magnetic field when current is sent through the coil.

## MAGNETS, COILS, AND INDUCTION

**Iron-Core Coil.** A coil having iron inside its windings. The iron is usually in the form of laminations, but it may also be pulverized iron mixed with a binding material.

**Filter Choke.** A coil used in a filter system to pass low frequency currents or direct current while limiting or blocking the flow of higher-frequency alternating or pulsating currents.

**Winding.** One or more turns of wire which make up a continuous coil. Used chiefly in coils, transformers and electromagnetic devices.

### MAGNETIC CIRCUITS

**Magnetic Circuit.** A complete path for magnetic lines of force. It always includes the permanent magnet or electromagnet which is producing the magnetic lines of force.

**Flux.** The magnetic lines of force in a magnet or in a magnet and its magnetic field. The flux, in magnetism, is similar to the current in electric circuits, since both terms refer to a flow.

**Magnetic Flux.** Total number of magnetic lines of force acting in a magnetic circuit.

**Leakage Flux.** That portion of the total magnetic flux which does not link all of the turns of wire in a coil or transformer and is consequently wasted.

**Air Gap.** A path for magnetic energy through air between two objects, such as between core sections of an iron-core transformer.

**Magnetic Field.** A region in space surrounding a magnet or a conductor through which current is flowing. The space in which appear the magnetic lines of force around a magnet or an electromagnet.

**Line of Force.** A path through space between magnetic poles along which acts the magnetic force as shown by lines drawn between the poles on a sketch. Imaginary lines used for convenience to designate the directions in which magnetic forces are acting throughout the magnetic field associated with a permanent magnet, electromagnet or current-carrying conductor.

**Permeability.** A measure of the ease with which magnetic flux or magnetic lines of force may be established in a magnetic circuit. The ratio of the number of flux lines produced by an electromagnet coil having a core of iron or steel to the flux produced by the same coil with no core other than air. The reciprocal of reluctance.

**Ampere-Turn.** A unit of magnetomotive force, equal to the number of amperes of current multiplied by the number of turns of a winding in which it flows.

## MAGNETS, COILS, AND INDUCTION

**Eddy Currents.** Circulating currents induced in conducting materials by varying magnetic fields. They are undesirable because they represent loss of energy and cause heating. Eddy currents are kept at a minimum by employing laminated construction for the iron cores of transformers.

**Hysteresis.** In the iron or steel of a magnetic circuit energized by a coil winding, the lag of magnetic flux behind the rate at which current increases in the coil, and the lag in reduction of flux behind the rate at which coil current decreases.

### DIRECTION OF MAGNETIC FLUX

With current flowing from left to right in the conductor of Fig. 8-1, magnetic lines of force circle the conductor in the direction shown; which is clockwise when looking at the end of the conductor through which current enters. When grasping a conductor with your right hand so that your thumb lies lengthwise of the conductor, if your thumb points in the direction of current flow, the tips of your fingers point in the direction that lines of force circle around the conductor.

When current flows as shown by Fig. 8-2 in the turns of a coil which is a helix or the winding of an electromagnet, magnetic flux through the center of the coil or in the magnet core is in the direction shown. When looking toward one end of the coil or core, if current flows clockwise the flux is flowing away from you, the south pole is toward you, and the north pole is away from you. The same general rule applies to the direction of flux in any magnetic circuit.

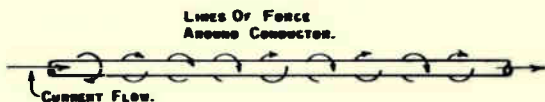


Fig. 8-1

### MAGNETIC CIRCUITS

Following are the principal properties of magnetic circuits, and the units which define the properties and describe the performance of a magnetic circuit.

**Magnetomotive force.** The force which causes magnetic lines of force, or magnetic flux, to flow around a magnetic circuit. It is measured in number of ampere-turns of the coil in which the force arises. Magnetomotive force for a magnetic circuit is similar to electromotive force for an electric current.



# MAGNETS, COILS AND INDUCTION

## ROUND MAGNET WIRE Approximate Diameter, 1000ths of an inch

GAGE NO.	Enamel	Enamel Single Cotton	Enamel Double Cotton	Enamel Single Silk	Enamel Double Silk	Single Cotton	Double Cotton	Single Silk	Double Silk
16	52.8	57.0	61.1	54.1	55.7	55.8	60.8	52.8	54.6
17	47.0	51.4	55.5	48.5	50.1	50.3	55.3	47.3	49.1
18	42.1	46.3	50.4	43.4	45.0	45.3	50.3	42.3	44.1
19	37.7	41.9	46.0	39.0	40.6	40.9	45.9	37.9	39.7
20	33.7	37.9	42.0	35.0	36.6	37.0	42.0	34.0	35.8
21	30.2	34.4	38.5	31.5	33.1	33.5	38.5	30.5	32.3
22	26.9	30.8	34.4	28.3	29.9	29.3	33.3	27.3	29.1
23	24.1	28.0	31.6	25.5	27.1	26.6	30.6	24.6	26.4
24	21.5	25.4	29.0	22.9	24.5	24.1	28.1	21.1	23.9
25	19.2	23.2	26.8	20.7	22.3	21.9	25.9	19.9	21.7
26	17.1	21.1	24.7	18.6	20.2	19.9	23.9	17.9	19.7
27	15.3	19.4	23.0	16.9	18.5	18.2	22.2	16.2	18.0
28	13.6	17.7	21.3	15.2	16.8	16.6	20.6	14.6	16.4
29	12.2	16.4	20.0	13.9	15.3	15.3	19.3	13.3	15.1
30	10.9	15.0	18.6	12.5	14.1	14.0	18.0	12.0	13.8
31	9.7	13.8	17.4	11.3	12.9	12.9	16.9	10.9	12.7
32	8.7	12.9	16.5	10.4	12.0	12.0	16.0	10.0	11.8
33	7.7	11.9	15.5	9.4	11.0	11.1	15.1	9.1	10.9
34	6.9	11.0	14.6	8.5	10.1	10.3	14.3	8.3	10.1
35	6.2	10.2	13.8	7.7	9.3	9.6	13.6	7.6	9.4
36	5.5	9.1	12.8	7.1	8.7	9.0	13.0	7.0	8.8
37	4.9	8.5	12.2	6.5	8.1	8.5	12.5	6.5	8.3
38	4.4	8.0	11.7	6.0	7.6	8.0	12.0	6.0	7.8
39	3.9	7.4	11.1	5.4	7.0	7.5	11.5	5.5	7.3
40	3.5	7.0	10.7	5.0	6.6	7.1	11.1	5.1	6.9
41	3.2								
42	2.9								

## MAGNETS, COILS, AND INDUCTION

**Magnetizing force.** This is magnetomotive force per inch of length of the magnetic circuit; so is ampere-turns per inch, or is equal to the number of ampere-

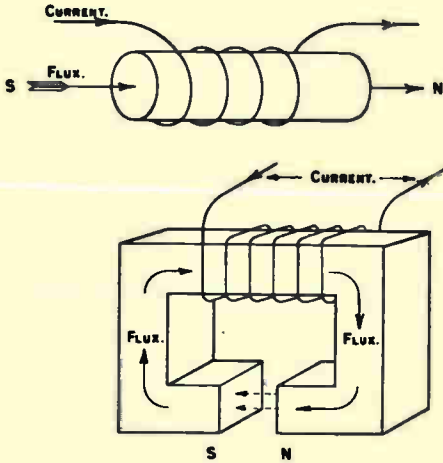


Fig. 8-2

turns divided by the number of inches of length of circuit. We might think of magnetizing force, in ampere-turns per inch, as similar to volts per inch of an electric circuit.

**Magnetic flux.** This is the total number of magnetic lines of force flowing around a magnetic circuit. The total flux in a magnetic circuit is in some ways similar to total current flow in amperes in an electric circuit.

**Flux density.** Dividing the total number of lines of force by the number of square inches of cross section of the magnetic circuit gives the flux density. Flux density is the number of magnetic lines per square inch of cross section of iron, air, or other material of the circuit at the point being considered. For the same total flux, the density will be greater where the circuit is of small cross section, and less where the cross section is greater.

**Permeability.** A measure of the ease with which a material carries magnetic flux; being similar in this way to the conductance of an electric circuit.

Permeability is equal to the total flux in number of lines divided by the total magnetizing force in ampere-turns.

When permeability is calculated by dividing the number of lines per square inch cross section by the

**ROUND MAGNET WIRE**  
Approximate Turns per Linear Inch, Close Wound

GAGE NO.	Enamel	Enamel Single Cotton	Enamel Double Cotton	Enamel Single Silk	Enamel Double Silk	Single Cotton	Double Cotton	Single Silk	Double Silk
16	18.9	17.6	16.4	18.5	18.0	17.9	16.5	19.0	18.8
17	21.3	19.5	18.0	20.6	19.9	19.9	18.1	21.1	20.4
18	23.8	21.6	19.8	23.0	22.2	22.1	19.9	23.6	22.7
19	26.5	24.9	21.7	25.6	24.6	24.4	21.8	26.4	25.2
20	29.7	26.4	23.8	28.6	27.3	27.0	23.8	29.4	27.9
21	33.1	29.1	26.0	31.7	30.2	29.8	26.0	32.8	31.0
22	37.2	32.5	29.1	35.3	33.4	33.1	30.0	36.6	34.4
23	41.5	35.7	31.7	39.2	36.9	37.6	32.7	40.6	37.9
24	46.5	39.4	34.5	43.7	40.8	41.5	35.6	47.4	41.8
25	52.1	43.1	37.3	48.3	44.8	45.6	38.6	50.2	46.1
26	58.5	47.4	40.5	53.7	49.5	50.2	41.8	55.6	50.7
27	65.4	51.5	43.5	59.2	54.1	54.9	45.0	61.7	55.6
28	73.5	56.5	47.0	65.8	59.5	60.2	48.5	68.4	60.9
29	82.0	61.0	50.0	71.9	64.5	65.4	51.8	75.2	66.2
30	91.7	66.7	53.8	80.0	70.9	71.4	55.5	83.3	72.5
31	103	72.4	57.4	88.5	77.5	77.5	59.2	91.7	78.7
32	116	77.5	60.6	96.1	83.3	83.3	62.5	100	84.7
33	130	84.0	64.5	107	90.9	90.0	66.2	110	91.7
34	145	91.0	68.5	118	99.0	97.0	69.9	121	99.0
35	161	98.0	72.4	130	108	104	73.5	132	106
36	182	110	78.1	141	115	111	76.9	143	114
37	204	118	82.0	154	124	118	80.0	154	120
38	227	125	85.4	167	132	125	83.3	167	128
39	257	135	90.0	185	143	133	87.0	182	137
40	286	143	93.4	200	152	141	90.0	196	145
41	313								
42	345								

MAGNETS, COILS, AND INDUCTION

## MAGNETS, COILS, AND INDUCTION

number of ampere-turns per inch of circuit length, the permeability of air is equal to 3.193.

If permeability is calculated by dividing the number of lines (or the number of maxwells) by the number of gilberts of magnetizing force, the permeability of air is 1.0.

The greater the permeability of a material, the greater will be the magnetic flux for a given magnetomotive force.

**Reluctivity.** A measure of the opposition of a material to flow of magnetic flux through it. Reluctivity is the reciprocal of permeability, or is equal to 1.0 divided by the permeability.

Reluctivity is equal to the magnetizing force divided by the flux density; or is equal to the number of ampere-turns per inch of circuit length divided by the number of magnetic lines per square inch of cross section.

**Reluctance.** A measure of the total opposition of a magnetic circuit to flow of magnetic flux through it. Reluctance in a magnetic circuit is similar to resistance in an electric circuit.

Reluctance is equal to the magnetomotive force divided by the magnetic flux, or is equal to the total number of ampere-turns divided by the total number of magnetic lines flowing in the circuit.

In addition to the "rational units" or practical units just explained, magnetic circuit calculations are carried out in C-G-S (centimeter-gram-second) units as follows:

Magnetomotive force	gilberts
Magnetizing force	gilberts per centimeter
Magnetic flux	maxwells
Flux density	maxwells per square centimeter
Reluctivity	oersteds per cubic centimeter
Reluctance	oersteds

Flux density is measured also in gausses per sq. cm.

Values in the C-G-S system are changed to equivalent values in the rational system as follows:

gilberts	x 0.7958	= ampere-turns
maxwells	x 1.0	= lines of flux
oersteds	x 0.7958	= reluctance, rational units
gausses	x 6.45	= lines per square inch

## INDUCTION

### DEFINITIONS

**Induction.** Electromagnetic induction is the production of an emf or voltage in a conductor which moves through a magnetic field and cuts across the lines of force, or when the magnetic field is moved across the conductor. Magnetic induction is the pro-

## MAGNETS, COILS, AND INDUCTION

duction of magnetism in a piece of iron or steel by magnetic lines of force from another magnet.

**Self-Induction.** The action by which any change of current, either an increase or a decrease, produces in the same circuit an electromotive force that opposes the change.

**Mutual Induction.** Production of a varying or alternating emf in one circuit by movement across its conductors of field lines arising in another nearby circuit in which the current is varying.

**Induced Voltage.** A voltage produced in a circuit by changes in the number of magnetic lines of force which are linking or cutting through the conductors of the circuit.

**Inductance.** That property of a coil or of a circuit which tends to prevent any change in current flow. Inductance is effective only when varying or alternating currents are present; it has no effect whatsoever upon the flow of direct current. Inductance is measured in henrys.

**Henry.** The practical unit of inductance.

**Millihenry.** A unit of inductance equal to one thousandth of a henry.

**Self-Inductance.** The property of a circuit whereby any change of current flowing in the circuit produces a counter emf that opposes the change that is taking place, an emf that tends to prevent an increasing current from increasing, and tends to prevent a decreasing current from decreasing. Measured in henrys. The symbol is  $L$ .

**Inductor.** A coil of wire, with or without an iron core, which, by its property of self-inductance, opposes changes of current.

**Counter Emf.** In a circuit containing self-inductance, a voltage produced by changes of current and which at every instant opposes the change of current that produces the voltage.

**Mutual Inductance.** The property of coupled or adjacent circuits by which each produces in the other an electromotive force when there is a change of current in either.

**Inductive Reactance.** Reactance due to the inductance of a coil or other part in an alternating current circuit. Inductive reactance is measured in ohms, and is equal to the inductance in henrys multiplied by the frequency in cycles, times the number 6.28; inductive reactance therefore increases with frequency.

**Reactance.** The opposition of a circuit or part of a circuit to flow of alternating current in the circuit or part; the opposition being due to inductance or capacitance, or to both inductance and capacitance, in the circuit or part. Reactance is measured in ohms. The

## MAGNETS, COILS, AND INDUCTION

combination of reactance and resistance produces impedance to flow of alternating current.

**Reactor.** A coil of wire, with or without an iron core, used to provide inductive reactance in a circuit.

### REACTANCE AND IMPEDANCE

Inductive reactance in ohms is equal to any of the following:

cycles x henrys x 6.2832

cycles x millihenrys x .006283

kilocycles x millihenrys x 6.2832

The number of cycles is the frequency of the alternating current. The number of henrys is the self-inductance of the coil or circuit. The number 6.2832 is approximately twice the ratio of the circumference of a circle to its diameter.

#### Impedance

When a circuit contains both inductive reactance and resistance, the opposition due to these two is the impedance in ohms.

Impedance in ohms is equal to the square root of the sum of the squares of the reactance and resistance, both in ohms, or

$$\text{Impedance in ohms} = \sqrt{(\text{reactance})^2 + (\text{resistance})^2}$$

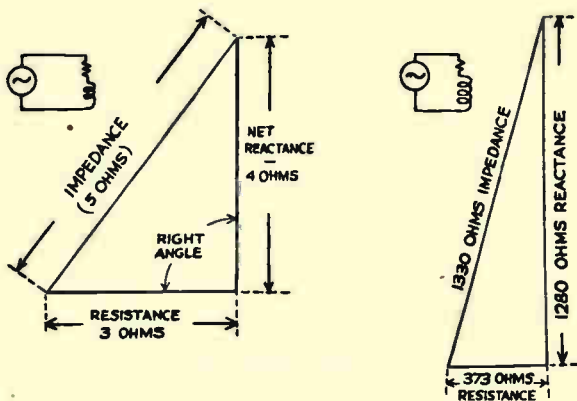


Fig. 8-3 The impedance triangle and how it may be used.

It is possible to determine the approximate impedance when we know the reactance and resistance by using the "impedance triangle" as shown by Fig. 8-3.

## MAGNETS, COILS, AND INDUCTION

Draw a right angle, or a square corner. Extend one side to a length proportional to the resistance in ohms. Extend the other side to a length proportional to the reactance in ohms. The distance between the far ends of the two extended lines is proportional to the impedance in ohms. This method applies when the resistance and reactance are in series with each other if the two are in separate units.

One triangle of Fig. 8-3 is laid out for a resistance of 3 ohms and a reactance of 4 ohms. The lengths might be 3 inches and 4 inches; but might also be any convenient units, such as quarters or eighths or hundredths of an inch. The length of the impedance side of the triangle, measured in the same unit, is the impedance in ohms.

The same formula, and the same type of impedance triangle, may be used when the reactance is capacitive reactance due to capacitance in the circuit, rather than to inductive reactance.

If the impedance is due to resistance and to both inductive reactance and capacitive reactance, the value of reactance to be used either in the formula or in the triangle is the difference (in ohms) between the two kinds of reactance.

## SERIES AND PARALLEL INDUCTANCES

The total self-inductance of any number of coils or self-inductances connected in series with one another is equal to the sum of their separate self-inductances. Adding together the numbers of henrys of the separate self-inductances gives the total inductance in henrys.

The total self-inductance of any number of coils or self-inductances connected in parallel with one another is equal to the reciprocal of the sum of the reciprocals of the separate self-inductances. Self-inductances connected in parallel are calculated just like resistances in parallel. Consequently, the total henrys of inductance for units in parallel may be calculated in exactly the same manner as for resistances in parallel. The method is described in the section on Resistors and Resistance.

Ohms of inductive reactance are directly proportional to inductances in henrys. Consequently, the total inductive reactance of any number of inductive reactances in series is equal to the sum of the separate reactances. The total inductive reactance of inductive reactances in parallel is equal to the reciprocal of the sum of the reciprocals of the separate reactances, and may be calculated in the same manner as for resistances in parallel.

## MAGNETS, COILS, AND INDUCTION

### DIRECTIONS OF FLUX, MOTION, AND CURRENT

When a conductor is moved through a magnetic field there is induced in the conductor an emf and, if the conductor is part of a closed circuit, a current, whose direction in the conductor depends on the relative directions of motion and field flux. The rule for direction of induced emf and current is as follows. See Fig. 8-4.

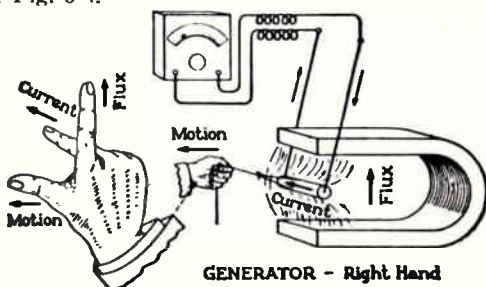


Fig. 8-4

Extend the thumb, forefinger and middle finger of the right hand so that they are at right angles, each to the other two. When the forefinger points in the direction of magnetic flux (north pole to south pole), and the thumb points in the direction of conductor motion, the middle finger points in the direction of induced emf and current in the conductor. This rule is called Fleming's right-hand rule, or the generator rule.

When a current-carrying conductor is in a magnetic field the conductor is moved through the field in a direction depending on the relative directions of field flux and of current in the conductor. The rule for direction of conductor motion is as follows. See Fig. 8.5.

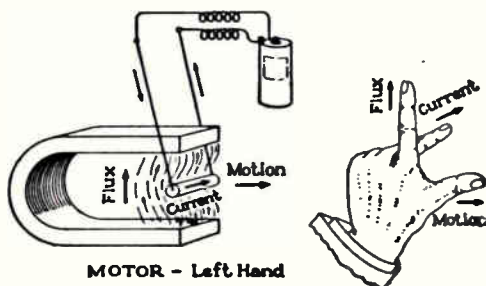


Fig. 8-5



## MAGNETS, COILS, AND INDUCTION

Extend the thumb, forefinger and middle finger of the left hand so that they are at right angles, each to the others. When the forefinger points in the direction of flux (north pole to south pole), and the middle finger in the direction of current through the conductor, the thumb points in the direction that the conductor is moved. This rule is called Fleming's left-hand rule, or the motor rule.

Note that in both rules the thumb points in the direction of motion, the forefinger in the direction of flux, and the middle finger in the direction of current.

### OHM'S LAW

*The strength of the current in any circuit is directly proportional to the electromotive force in that circuit and inversely proportional to the resistance of that circuit, i.e., is equal to the quotient arising from dividing the electromotive force by the resistance.*

Let  $E$  = electromotive force in volts

$R$  = resistance in ohms

$I$  = strength of current in amperes

$$\text{Then } I = \frac{E}{R}, R = \frac{E}{I}, E = IR$$

The ohm, ampere, and volt are defined in terms of one another as follows: Ohm, the resistance of a conductor through which a current of 1 ampere will pass when the electromotive force is 1 volt. Ampere, the quantity of current which will flow through a resistance of 1 ohm when the electromotive force is 1 volt. Volt, the electromotive force required to cause 1 ampere to flow through a resistance of 1 ohm.

## Section 9

# CAPACITORS AND CAPACITANCE

### DEFINITIONS

**Charge.** A quantity of electricity held on an insulated object. The electrical energy stored in a condenser. When an object has more electrons than normal, it has a negative charge. When an object has fewer electrons than normal, it has a positive charge.

**Negative Charge.** The electrical condition of a body on which are more than the normal quantities of negative electrons, so that the body has more negative electricity than has an uncharged or neutral body.

**Positive Charge.** The electrical condition of a body which has less than the normal quantity of negative electrons, so that the body has less negative electricity than one which is uncharged or is neutral.

**Electric Field.** A region in space surrounding a charged object. Lines drawn to represent the direction in which the electric field will act on other charged objects are called electric lines of force. A moving electric field, such as that associated with electrons in motion or with a radio wave, is always accompanied by a moving magnetic field. The space between two opposite electric charges, in which appear electrostatic lines of force.

**Electrostatic.** Pertaining to electric charges, to capacitors, to electric fields and lines of electric force, and to anything having to do with electricity at rest.

**Capacitance.** The ability to receive and retain an electric charge. Permittance. The symbol is C. The electrical size of a capacitor, determining the amount of electrical energy, which can be stored by a given voltage. Capacitance is measured in farads, microfarads (mfd.) and micro-microfarads (mmfd.); 1 mfd. is equal to 1,000,000 mmfd.

**Capacity.** A name sometimes applied to capacitance.

**Farad.** The basic unit of capacitance, but too large for practical use. The microfarad, equal to one millionth of a farad, is a more practical unit. An even smaller unit, the micro-microfarad, is equal to one millionth of a microfarad.

**Microfarad.** A unit of capacitance equal to one millionth of a farad. The microfarad is the capacity unit most commonly used. It is abbreviated as mfd.

**Micro-Microfarad.** A unit of capacitance equal to one millionth of a microfarad, and abbreviated as mmfd.

**Distributed Capacitance.** Capacitance distributed between conducting elements such as wires, as distin-

## CAPACITORS AND CAPACITANCE

gished from capacitance concentrated in a capacitor. Usually used to specify the small capacitance existing between the turns of wire in a coil.

**Capacitor.** Two conducting surfaces separated from each other by an insulating material such as air, oil, paper, glass or mica. A capacitor is capable of storing electrical energy. Capacitors are used to block the flow of direct current while allowing alternating currents to pass. The electrical size or capacitance of a capacitor is specified in microfarads and micro-microfarads.

**Condenser.** A name sometimes applied to a capacitor.

**Fixed Capacitor.** A capacitor having a definite capacitance value which cannot be adjusted.

**Paper Capacitor.** A fixed capacitor employing foil plates separated by paraffined or oiled paper.

**Mica Capacitor.** A capacitor which employs sheets of mica as the dielectric material which insulates adjacent plates from each other.

**Electrolytic Capacitor.** A fixed capacitor in which the dielectric is a thin film of gas formed on the surface of one aluminum electrode by a liquid or paste electrolyte.

**Dry Electrolytic Capacitor.** An electrolytic capacitor in which the electrolyte is a paste rather than a liquid, to permit using the condenser in any position without danger of the electrolyte leaking out.

### DIELECTRIC CONSTANTS

Air	1.0
Celluloid	7 to 10
Fibre, vulcanized	5 to 8
Glass	4 to 10
Insulation molded, phenolic base	5 to 7.5
Insulation, molded, shellac base	4 to 7
Marble	9 to 12
Mica	4 to 8
Oil, castor	4.7
Oil, cottonseed	3.1
Oil, transformer	2.5
Paper, dry	1.5 to 3
Paper, treated, waxed	2.5 to 4.0
Porcelain, unglazed	5 to 7
Rubber, hard	2 to 4
Shellac	3 to 3.7
Silk	4.6
Sulphur	3.0 to 4.2
Water, distilled	81
Wax, bee's	3.2
Wax, paraffin	2 to 3
Wood, dry, maple	3.0 to 4.5
Wood, dry, oak	3 to 6

## CAPACITORS AND CAPACITANCE

**Filter Capacitor.** A capacitor used in a filter system to permit passage of higher-frequency currents while limiting or blocking the flow of lower-frequency currents and direct current.

**Voltage Rating of a Capacitor.** The maximum sustained voltage which can safely be applied across the terminals of a capacitor without causing breakdown of the insulation between condenser plates.

**Dielectric Constant.** The dielectric constant of a material is the ratio of the capacitance of a capacitor using that material as its dielectric to the capacitance of a capacitor otherwise similar but having air or a vacuum for the dielectric. The increase of capacitance caused by using the material instead of air for the dielectric.

**Capacitive Reactance.** The effect of capacitance in opposing the flow of alternating or pulsating current. The reactance which a condenser offers to a.c. or pulsating d.c. It is measured in ohms, and decreases as frequency and capacity are increased.

### CAPACITIVE REACTANCE

Capacitive reactance in ohms is equal to either of the following:

$$\frac{159155}{\text{cycles} \times \text{microfarads}}$$

$$\frac{159154600}{\text{kilocycles} \times \text{micro-microfarads}}$$

$$\frac{1}{6.2832 \times \text{cycles} \times \text{farads}}$$

The number of cycles is the frequency of the alternating current or voltage. Microfarads, micro-microfarads, or farads are the capacitances.

The values of impedance due to capacitive reactance and resistance see under "Reactance and Impedance" in the section on Magnets, Coils and Induction.

### SERIES AND PARALLEL CAPACITANCES

The total capacitance of any number of capacitances connected in series with one another is equal to the reciprocal of the sum of the reciprocals of the separate capacitances. Consequently, the total microfarads or other capacitance units for capacitances in series may be calculated in the same manner as for resistances in parallel. The method is described in the section on Resistors and Resistance.

The combined capacitance of two capacitances connected in series is equal to their product divided by their sum. That is,

## CAPACITORS AND CAPACITANCE

$$\text{Combined capacitance} = \frac{\text{1st capacitance} \times \text{2nd capacitance}}{\text{1st capacitance} + \text{2nd capacitance}}$$

The total capacitance of any number of capacitances connected in parallel with one another is equal to the sum of the separate capacitances.

When calculating total or combined capacitances, all the separate capacitances must be given in the same unit. All must be either in farads, microfarads, or in micro-microfarads.

Capacitive reactances in ohms are treated exactly the same as resistances in ohms. That is, the total capacitive reactance of any number of capacitive reactances in series is equal to the sum of the separate reactances in ohms. Then, following the same rule that applies to resistances, the total capacitive reactance of any number of capacitive reactances connected in parallel is equal to the reciprocal of the sum of the reciprocals of the separate reactances.

Note that reactances, whether capacitive or inductive, are handled just like resistances when combined in series or in parallel. However, as explained above, paralleled capacitances (microfarads, etc.) are added like series resistances, while series capacitances are handled like parallel resistances. It makes a difference whether the problem involves capacitances or the reactances which they cause.

### CAPACITANCE OF A CAPACITOR

The approximate capacitance of any capacitor may be found from this formula:

$$C = \frac{A \times K \times N}{4.444 \times D}$$

- A. Area in square inches of one side of one plate, assuming that all plates are of same size.
- C. Capacitance in micro-microfarads.
- D. Distance in inches between plates, or thickness of the dielectric.
- K. Dielectric constant of material between the plates.
- N. Total number of plates minus 1. In a 2-plate capacitor  $N = 1$ , in a 7-plate capacitor  $N = 6$ , etc.

Example: What is the capacitance of a capacitor having 22 plates, each 3 inches square, with dielectric material 0.005 inch thick whose dielectric constant is 6?

Plates 3 inches square have an area on one side of  $3 \times 3$ , or 9 square inches, which is the value of A. The total number of plates minus 1 is  $22 - 1$ , or is 21, which is the value of N. Placing the values in the formula gives,

$$C = \frac{9 \times 6 \times 21}{4.444 \times 0.005} = \frac{1134}{0.02222} = 51035 \text{ mmfd.}$$

## CAPACITORS AND CAPACITANCE

The capacitance is about 50,000 mmfd. or is about 0.05 mfd.

### TESTING OF CAPACITORS

Capacitors of either the paper type or the electrolytic type may be tested for open circuits, short circuits, loss of capacitance, and excessive leakage with the instrument whose circuit diagram is shown by Fig. 9-1

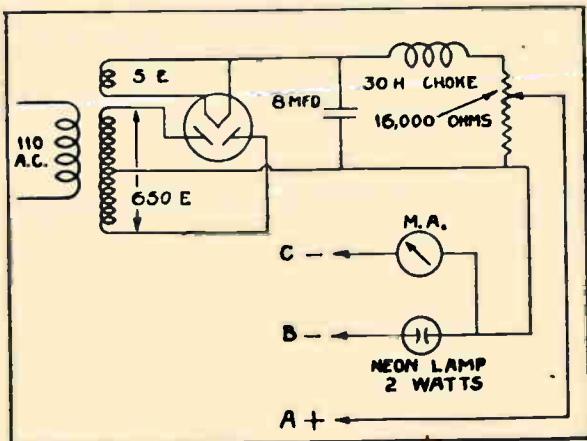


Fig. 9-1

The tester includes a transformer with two secondary windings, one a high-voltage winding and the other a low voltage winding for the heater or filament of a full-wave rectifier tube. To the rectifier output is connected a filter consisting of an 8-mfd. capacitor and a 30-henry filter choke such as used in radio power supplies. Across the filter output is a 16,000-ohm voltage divider or potentiometer. In one of the negative leads is an 0-100 milliamperere meter, and in the other is a small neon lamp. To use the tester proceed as follows:

Connect capacitor across leads A and B; if neon lamp does not flash, capacitor is open; if lamp glows continuously, capacitor is shorted. Allow unit to remain connected for a minute and watch neon lamp; if it flashes frequently, capacitor is leaky. This leakage test applies to paper capacitor only. As electrolytic capacitors draw a small leakage current continuously, tests with a neon lamp are valueless; therefore, a meter is used. Connect electrolytic capacitor unit to leads A and C and read meter. If current exceeds  $\frac{1}{4}$

## CAPACITORS AND CAPACITANCE

milliampere per microfarad of rated capacity, the capacitor is leaky. If leakage current is very small, capacitor is probably dried out. Any capacitor giving abnormal readings should be replaced in order to secure proper starting torque of the motor, and to prevent damage to the motor due to failure to start if the capacitor is defective.

### TESTING ELECTROLYTIC CAPACITORS

The approved procedure for testing the electrolytic capacitor used with capacitor type motors illustrates the direct and simple character of the checks employed in the field, and shows what may be done to positively check an electrical device with very little equipment. The complete check may be divided into tests for capacity, shorts, opens, and grounds.

Determination of the capacity is effected by disconnecting all leads and then arranging the capacitor across the circuit with a suitably fused ammeter in series. On a 60-cycle circuit the capacitance in microfarads is obtainable from the formula.

$$C = 2650 \times \frac{\text{Amperes}}{\text{Volts.}}$$

Should the capacitance prove to be considerably below the rated value marked on the case, the capacitor should be replaced. Capacitors may exceed rated value by 40% without indicating a defect.

The same connection may be used to test for opens. If the ammeter does not read, the capacitor is open. To test for shorts, apply rated voltage and frequency to capacitor with a fuse in series; if fuse blows, the capacitor is shorted. A 10-ampere fuse will be suitable for testing any 110-volt capacitor of 150 microfarads capacitance or less.

To test for grounds apply 110-volts between one capacitor terminal and the case with a fuse in series; if the fuse blows, capacitor is grounded. Sometimes small sparks may be observed between the line wire and the metal container when the circuit is broken. This action is due to leakage current through the electrolyte and does not indicate a defect. If the capacitor is grounded, the fuse will blow.

Thus with the aid of nothing more than a fuse, the electrolytic capacitor may be checked for every possible fault except low capacity—without removing it from the machine. For capacity readings, a low reading ammeter—about 0.1 ampere—should be used. With this meager equipment capacitors may be checked quickly, positively, and completely.

## Section 10

### POWER

#### DEFINITIONS

**Power.** The rate at which electrical energy is delivered and consumed. Electrical power is measured in watts.

**Energy** The ability to do work, or to cause movement against an opposing force when utilized in suitable equipment. Energy exists in bodies that are in motion, in bodies such as springs that are in a strained position, in electromotive force, in chemicals, and in heat. Energy existing in one form may be changed to energy existing in other forms; as when chemical energy in a battery changes to electromotive force.

**Work.** A force multiplied by the distance through which it causes a mass or weight to move. If a force of one pound causes a movement of one foot, the work done is equal to one foot-pound, this being one of the units in which work may be measured. Work is the result of a force acting against some form of opposition to motion. It is measured as the product of the force and the distance through which it acts.

**Watt.** The practical unit of electric power. In a direct-current circuit the expended power in watts is equal to the number of volts applied to the circuit multiplied by the number of amperes flowing in the circuit due to the applied voltage. In an alternating-current circuit the watts of power consumed are equal to the number of applied volts multiplied by the number of amperes of current, and multiplied by the power factor. Except in an alternating-current circuit containing no appreciable inductance or capacitance, or containing only resistance, the watts of power will be less than the volt-amperes.

**Kilowatt.** One thousand watts.

**Joule.** A unit of electrical energy or of work, equal to the energy transferred by a power rate of one watt continuing for one second. The work done by sending one ampere of electricity through a resistance of one ohm for one second.

**Efficiency.** The ratio of energy output to energy input, usually expressed as a percentage. A perfect electrical device would have an efficiency of 100%.

#### POWER FORMULAS

Letters and abbreviations used in the following formulas have these meanings:

- I Current, in amperes.
- E Potential difference, in volts.



## POWER

- R Resistance, in ohms.  
 P Power, in watts.  
 kw Power, in kilowatts.  
 va Apparent power, in volt-amperes. Volt-amperes are equal to the number of volts multiplied by the number of amperes. In circuits containing inductance or capacitance the power in volt-amperes usually is less than the power in watts. Volt-amperes of power multiplied by the power factor equal watts of power.  
 kva Apparent power, in kilovolt-amperes.  
 hp Output power, in number of horsepower.  
 eff Efficiency, as a decimal fraction, not as a percentage. For example, efficiency of 85% is efficiency of 0.85.  
 PF Power factor, as a decimal fraction, not as a percentage. Power factor is the fraction of the apparent power, in volt-amperes, that becomes useful power, measured in watts.

### Direct-current Circuits

$$I = \frac{E}{R} \qquad I = \frac{P}{E} \qquad I = \frac{1000 \times \text{kw}}{E}$$

$$I = \sqrt{\frac{P}{R}} \qquad I = \frac{746 \times \text{hp}}{E \times \text{eff}}$$

$$E = I \times R \qquad E = \frac{P}{I} \qquad E = \sqrt{R \times P}$$

$$R = \frac{E}{I} \qquad R = \frac{P}{I^2} \qquad R = \frac{E^2}{P}$$

$$P = E \times I \qquad P = \frac{E^2}{R} \qquad P = I^2 \times R$$

$$\text{kw} = \frac{E \times I}{1000} \qquad \text{kw} = \frac{E^2}{1000 \times R} \qquad \text{kw} = \frac{I^2 \times R}{1000}$$

$$\text{hp} = \frac{I \times E \times \text{eff}}{746}$$

### Single-phase A-c Circuits

$$I = \frac{\text{va}}{E} \qquad I = \frac{1000 \times \text{kva}}{E}$$

$$I = \frac{P}{E \times \text{PF}} \qquad I = \frac{1000 \times \text{kw}}{E \times \text{PF}}$$

## POWER

$$I = \frac{746 \times \text{hp}}{E \times \text{PF} \times \text{eff}}$$

$$E = \frac{P}{I \times \text{PF}}$$

$$P = E \times I \times \text{PF} \quad \text{kw} = \frac{E \times I \times \text{PF}}{1000}$$

$$\text{va} = I \times E \quad \text{kva} = \frac{I \times E}{1000}$$

$$\text{hp} = \frac{I \times E \times \text{PF} \times \text{eff}}{746}$$

$$\text{PF} = \frac{P}{E \times I}$$

### Three-phase A-c Circuits

$$I = \frac{\text{va}}{1.73 \times E} \quad I = \frac{577 \times \text{kva}}{E}$$

$$I = \frac{P}{1.73 \times E \times \text{PF}} \quad I = \frac{577 \times \text{kw}}{E \times \text{PF}}$$

$$I = \frac{431 \times \text{hp}}{E \times \text{PF} \times \text{eff}}$$

$$E = \frac{\text{va}}{1.73 \times I} \quad E = \frac{P}{1.73 \times I \times \text{PF}}$$

$$P = 1.73 \times E \times I \times \text{PF} \quad \text{kw} = \frac{1.73 \times E \times I \times \text{PF}}{1000}$$

$$\text{va} = 1.73 \times E \times I \quad \text{kva} = \frac{1.73 \times E \times I}{1000}$$

$$\text{hp} = \frac{E \times I \times \text{PF} \times \text{eff}}{431}$$

$$\text{PF} = \frac{P}{1.73 \times E \times I} \quad \text{PF} = \frac{577 \times \text{kw}}{E \times I}$$

### Two-phase A-c Circuits

$$I = \frac{P}{2 \times E \times \text{PF}} \quad I = \frac{500 \times \text{kva}}{E}$$

## POWER

$$I = \frac{va}{2 \times E} \qquad I = \frac{500 \times kw}{E \times PF}$$

$$I = \frac{373 \times hp}{E \times PF \times eff}$$

In the common conductor of a 3-wire 2-phase circuit the current in amperes is equal to 1.41 times that calculated from any of the above formulas.

$$E = \frac{P}{2 \times I \times PF} \qquad E = \frac{500 \times kw}{I \times PF}$$

$$E = \frac{va}{2 \times I} \qquad E = \frac{500 \times kva}{I}$$

In a 3-wire 2-phase circuit the voltage between either of the outer conductors and the common conductor is equal to 0.707 times the voltage between the two outers.

The voltage between the two outers is equal to 1.41 times that between either outer and the common.

$$P = 2 \times E \times I \times PF \qquad kw = \frac{E \times I \times PF}{500}$$

$$va = 2 \times E \times I \qquad kva = \frac{E \times I}{500}$$

$$hp = \frac{E \times I \times PF \times eff}{373}$$

$$PF = \frac{P}{2 \times E \times I} \qquad PF = \frac{500 \times kw}{E \times I}$$

**Power transmitted by shafting.**

$$hp = \frac{\text{torque, foot-lbs.} \times \text{speed, rpm.}}{5250}$$

$$\text{torque, ft.-lbs.} = \frac{5250 \times hp}{\text{speed, rpm}}$$

**Power measured by prony brake.**

$$hp = \frac{2 \times 3.1416 \times \text{rpm} \times \text{force, lbs.} \times \text{lever length, ft.}}{33,000}$$

$$hp = \frac{\text{rpm} \times \text{force, lbs.} \times \text{lever length, ft.}}{5250}$$

## POWER

rpm, speed of pulley or shaft, revs. per minute.

force, lbs., exerted on scale.

lever length, ft., from pulley or shaft center to point of contact on scale.

### Power to drive a pump.

$$\text{hp} = \frac{\text{gals. per min.} \times \text{total head, in feet}}{3960 \times \text{efficiency of pump}}$$

efficiency usually is 0.50 to 0.85.

### Power to drive a fan.

$$\text{hp} = \frac{\text{cu. ft. air per min.} \times \text{pressure, in of water}}{6350 \times \text{efficiency of fan}}$$

centrifugal fan efficiency usually 0.50 to 0.70.

propellor fan efficiency as low as 0.35.

horsepower varies as the cube of the fan speed.

### Power to operate an elevator.

$$\text{hp} = \frac{\text{lbs. of unbalanced load} \times \text{speed, ft. per min.}}{33,000 \times \text{efficiency}}$$

efficiency usually about 0.50.

### Power to hoist any load.

$$\text{hp} = \frac{\text{weight, lbs.} \times \text{ft. per min.} \times \text{sine of angle}}{33,000}$$

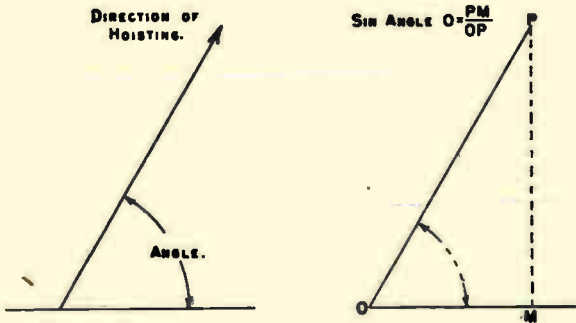


Fig. 10-1

## POWER

The angle is that between the line of hoisting and a horizontal line, as in Fig. 10-1. The sine of any angle may be found by laying out the angle to any convenient scale, measuring the distances O-P and P-M, then dividing P-M by O-P. For example, if O-P measures 8 inches and P-M measures 7 inches, the sine of the angle is equal to 7 divided by 8, or to 0.875. If the angle is known in degrees, the sine may be found from a table of natural sines. For vertical hoisting the angle with the horizontal is 90° and its sine is 1.0, and the formula becomes weight times feet per minute divided by 33,000.

### Power of a waterfall.

$$\text{hp} = \frac{62 \times \text{section} \times \text{velocity} \times \text{head}}{33,000}$$

$$\text{hp} = \frac{\text{section} \times \text{velocity} \times \text{head}}{532}$$

Section is cross section in square feet of the stream of water flowing.

Velocity is the speed of flow in feet per minute.

Head is the height of the fall in feet.

## POWER AND ENERGY CONVERSION UNITS

Equivalent values of kilowatts, kilowatt-hours, horse power, and horsepower-hours in other units.

	Kilowatts	Horsepower Kilowatt- Hours	Horsepower —Hours
Watts	1000		745.7
Watt-hours		1000	
Kilowatt-Hours			0.7457
Horsepower	1.341		
Horsepower-hours		1.341	
Foot-pounds		2655200	1980000
Ft.-lbs. per minute	44,254		33000
Ft.-lbs. per second	737.56		550
Btu's		3415	2546.5
Btu's per hour	3415		2546.5
Btu's per minute	56.92		42.44
Lbs. water evaporated at 212°		3.52	2.62
Lbs. per hour	3.52		2.62
Kilogram-meters		367100	
Joules		3600000	273740

## Section 11

# METERS AND MEASUREMENTS

### DEFINITIONS

**Ammeter.** An instrument used for measuring the current flow in amperes in a circuit.

**Shunt.** A resistor placed across the terminals of an ammeter to allow a definite part of the circuit current to go around the meter.

**Milliammeter.** A measuring instrument which measures current flow in milliamperes.

**Voltmeter.** An instrument for measuring differences of potential or voltage and indicating the differences directly in a number of volts on its scale.

**Multiplier.** A resistor used in series with a voltmeter to increase the range of the meter.

**Voltammeter.** A voltmeter and an ammeter in a single case, or sometimes an instrument for measuring watts (volts x amperes) in a direct-current circuit.

**Ohmmeter.** A test instrument which measures and indicates directly the resistance of a part or the resistance of a part or the resistance between any two points in a circuit. It consists essentially of a milliammeter in series with a suitable d.c. voltage and suitable series or shunt resistors.

**Wattmeter.** A meter for measuring and indicating directly in watts on its scale the power being consumed in a circuit or in equipment to which the wattmeter is connected.

**Moving Coil Meter.** A current-actuated electric meter consisting of a permanent magnet between the poles of which is suspended a wire coil through which flows all or part of the current to be measured. The coil is mounted between end bearings and to it is attached the indicating pointer. The coil and pointer are moved by reaction between the magnetic fields of the permanent magnet and of the current-carrying coil.

**Rectifier Meter.** A moving coil direct-current meter equipped with a rectifier which changes alternating current or voltage to be measured into direct current or voltage which will operate the meter and cause it to indicate.

**Thermocouple Meter.** A moving coil meter equipped with a thermocouple heated by alternating current to be measured and producing a direct current that actuates the meter.

**Hot Wire Meter.** A current-indicating meter whose pointer is allowed to move across the dial when a wire inside the meter is heated and expanded by the measured current flowing through this wire.

## METERS AND MEASUREMENTS

**Sensitivity.** In electrical measuring instruments, a measure of the current, voltage or power required to operate the meter itself and to cause its indicator to move. The less the required power the higher is the sensitivity.

**Ohms-Per-Volt.** A sensitivity rating for meters. It is obtained by dividing the resistance in ohms of any meter range by the full scale voltage reading of the meter at that range. The higher the ohms-per-volt rating, the more sensitive is the meter.

**Wheatstone Bridge.** An instrument that allows calculation of values of resistance, inductance or capacitance in parts of circuits connected into the bridge circuit; the calculation involving one ratio of resistances which are adjustable in the bridge circuit, and another ratio in which one value is known and the other is the value of the unknown resistance, inductance or capacitance. When adjustments make the two ratios equal the bridge is said to be balanced, and the condition of balance may be indicated by a galvanometer or other current-sensitive device.

**Oscillograph.** A test instrument which records photographically the wave form of a varying current or voltage.

**Oscilloscope.** A test instrument which shows visually on a screen the wave form of a varying current or voltage.

## METER CONSTRUCTION AND CONNECTIONS

The construction of a moving coil meter is shown by Fig. 11-1. For use as a voltmeter there is connected in series with the moving coil winding a resistor indicated by the broken-line coil. An additional multiplier resistor may be connected in series with the meter, external to the housing.

For use as a current-measuring instrument, ammeter or milliammeter, the moving coil terminals are connected to the ends of a shunt resistor which may be inside the meter case or mounted externally, or there may be an external shunt in addition to an internal one.

Voltmeters always are connected to the two points between which a potential difference is to be measured. This connection would be across the terminals of a source or a load, or across a line, as indicated at **A** in Fig. 11-2.

An ammeter or its shunt, or any other current-measuring instrument, is connected in series with the path in which current flow is to be measured, as indicated at **B** in Fig. 11-2. For connection of a current-

## METERS AND MEASUREMENTS

measuring instrument it is necessary to open the circuit whose current is to be measured, then to complete the circuit through the meter or the shunt.

### MULTIPLIERS FOR VOLTMETERS

Many voltmeters and ammeters are made with a standard moving coil having a resistance of  $2\frac{1}{2}$  ohms and designed to give full scale deflection of the pointer with a current of 20 milliamperes, or .020 amperes.

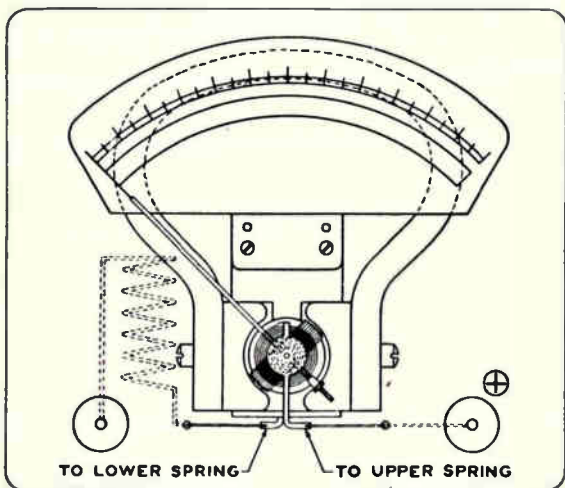


Fig. 11-1

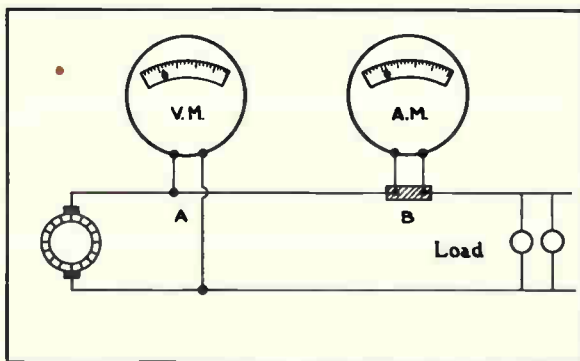


Fig. 11-2



## METERS AND MEASUREMENTS

According to Ohm's Law,  $I \times R = E$ , or  $.020 I \times 2.5 R = .050E$ , or 50 millivolts drop, or pressure applied to force full scale current through this coil. A coil having  $2\frac{1}{2}$  ohms for a 50 millivolt reading would be on a basis of 50 ohms per volt, as one volt or 1,000 m.v.  $\div$  50 m.v. = 20, and  $20 \times 2.5 = 50$ .

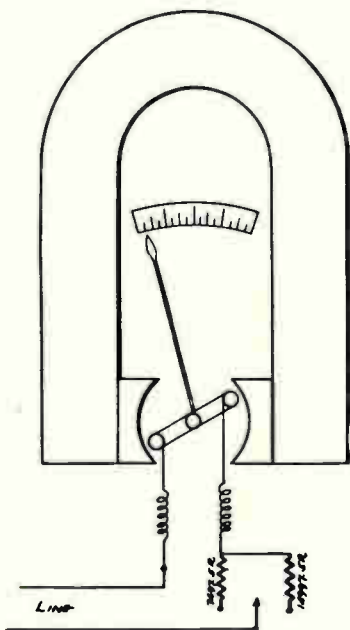


Fig. 11-3

Now if we wish to use this 50 m.v. meter to measure 100 m.v., or double the present voltage rating, we should simply double the resistance of the meter circuit or add  $2\frac{1}{2}$  ohms more resistance in series with the  $2\frac{1}{2}$  ohm moving coil. Then  $2\frac{1}{2} + 2\frac{1}{2} = 5$  ohms total resistance, which when connected across a 100 m.v. circuit would draw  $.100 \div 5$  or .020 amperes and again give full scale deflection. If we now remark or recalibrate the scale for 100 m.v., we have doubled the range of the meter.

You can readily see that if the  $2\frac{1}{2}$  ohm coil were connected on a circuit of double its rated voltage without increasing the resistance, the coil would receive double current and be burned out. Therefore,

## METERS AND MEASUREMENTS

in changing voltmeter resistances to adapt the meter for correct readings of higher voltage values, we simply use the following formula to determine the correct resistors to use in series with the meter coil:

$$\frac{\text{Desired voltage range}}{\text{Full scale meter coil current}} = \text{Total resistance for meter circuit}$$

Then by subtracting the resistance of the moving coil from this total resistance we can determine the amount of extra resistance to use in series for the higher readings. For example, suppose we wish to adapt this same meter element for a full scale reading of 150 volts, and for safe use on a 150 volt circuit.

$$\text{Then } \frac{150 \text{ E}}{.020 \text{ I}} = 7500 \text{ R. for total resistance}$$

Then  $7500 - 2.5 = 7497.5$  ohms of additional resistance to be used.

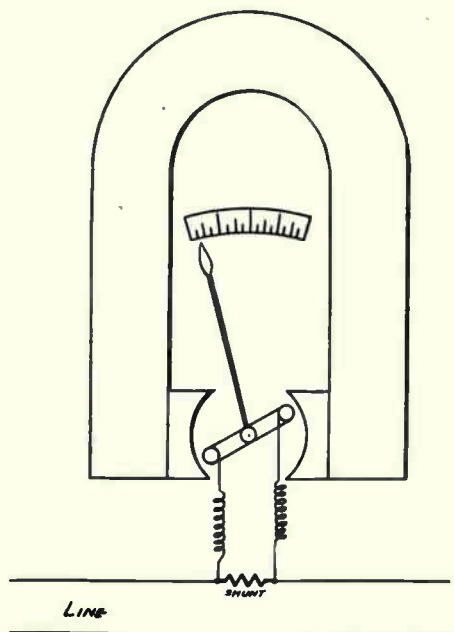


Fig. 11-4

## METERS AND MEASUREMENTS

If we wish to use the same meter for dual service or 150 and 300 volt circuits, we can arrange another resistor of 14997.5 ohms as shown in Fig. 11-3. Then by connecting the wires of the circuits to be tested to the proper terminals or resistors we can measure either voltage. Some multiple range meters have these extra resistors located inside the case and connected to proper terminals. These meters may also have the scale marked for 3 or more voltage ranges.

### SHUNTS FOR AMMETERS

Ammeters may be adapted to measure various ranges of current by changing the resistance of the shunts which are used with this same standard meter element and  $2\frac{1}{2}$  ohm moving coil. Using only the meter coil without any shunt the instrument's capacity and full scale reading would be only 20 milliamperes. If we wish to change it to measure current up to 100 M.A. or 5 times its former rating, we would place in parallel with the moving coil a shunt having a resistance one-fourth that of the coil or,  $2.5 \div 4 = .625$  ohms resistance for the shunt.

With this shunt connected in parallel with the meter as shown in Fig. 11-4, the current will divide in inverse proportion to the resistance of the two parallel paths, and  $4/5$  of the current, or 80 M.A. will pass through the shunt, while  $1/5$  of the current, or 20 M.A. will pass through the meter coil.

When making such changes for scale readings of 2 amperes or less, we should determine the shunt resistance according to the desired division of current between the meter coil and the shunt, as we have just done in the foregoing problem. This is due to the fact that in order to obtain readings which are accurate at least within one per cent on such small current loads, we must consider the amount of current which flows through the meter element. However, for changes over 2 amperes the following simple formula can be used to determine the shunt resistance:

$$\frac{\text{Voltage rating of meter coil}}{\text{Desired current capacity}} = \text{Resistance of shunt.}$$

Then if we want to change this same type of meter with the 50 millivolt coil to measure currents up to 10 amperes at full scale reading,

$$\frac{.050}{10} = .005 \text{ ohm shunt}$$

to be used in parallel with the meter element. Note that the shunt resistance is  $1/500$  of the meter coil resistance, and the meter coil current of .020 is  $1/500$

## METERS AND MEASUREMENTS

of the new full scale current of 10 amperes. If we desire to change this type of meter to read 200 amperes, then,

$$\frac{050}{200} = .00025 \text{ ohm shunt.}$$

### POWER MEASUREMENTS FOR ALTERNATING-CURRENT CIRCUITS

Voltmeters and the potential elements of wattmeters always must be connected across the line, as at **A** in Fig. 11-2, while ammeters and the current elements of wattmeters always must be connected in series with the line, as at **B**. Otherwise the results will be failure to obtain measurements, destruction of the measuring instruments, or damage to other equipment.

The internal connections of one type of wattmeter are shown by Fig. 11-5, and those for a dynamometer type adapted to alternating-current measurements are shown by Fig. 11-6.

#### Single-phase Circuits

Fig. 11-6 shows the proper connections for a voltmeter, an ammeter, and a wattmeter in a single-phase circuit. Note that the voltmeter and potential coil of the wattmeter are both connected across the line; and that the ammeter and the current coil of the wattmeter are both connected in series with the line.

It does not matter in which side of the line the ammeter and wattmeter are connected, as all the current to the motor must flow through each line wire, and correct total readings can be obtained from either wire.

The wattmeter can be used with the voltmeter and ammeter to determine the power factor of the machine. The wattmeter will read the true power, and the product of the voltmeter and ammeter readings will give the apparent power. Then, dividing the true power by apparent power will give the power factor.

#### High-voltage Circuits

Fig. 11-7 shows the meters and connections for measuring the voltage, current, and power of a high-voltage circuit, where instrument transformers are used.

Special transformers are used to reduce the voltage and current at the meters to a definite fraction of the voltage and current on the line. These transformers are called current transformers and potential transformers, and are designed to maintain on their secondaries a fixed ratio of the voltage or current on their primaries. The meters used with such transformers can, therefore, be calibrated to read the full voltage, current, or power on the line.

## METERS AND MEASUREMENTS

The potential transformer, on the left in Fig 11-8, has its primary winding connected across the line, and its secondary supplies both the voltmeter and the potential coil of the wattmeter, which are connected in parallel.

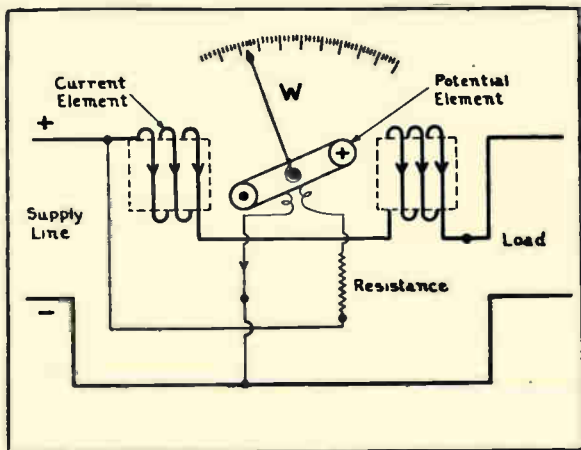


Fig. 11-5

The current transformer on the right has its primary coil connected in series with the line, and its secondary supplies both the ammeter and the current coil of the wattmeter, which are connected in series.

You will note that the secondaries of both transformers are grounded, to prevent damage to instruments and danger to operators in case the insulation between the high-voltage primary and the low-voltage secondary coils should fail.

The potential transformer is equipped with fuses in its primary leads.

**Never disconnect an ammeter from a current transformer without first short-circuiting the secondary coil of the transformer.**

### Three-phase Circuits, Current Measurements

Fig. 11-9 shows a three-phase motor with an ammeter connected in one of its phase wires to measure the current. If the motor is operating properly, the current should be very nearly the same, or balanced in all three phases.

Where the current of a three-phase system is known to be balanced at all times, one ammeter permanently

## METERS AND MEASUREMENTS

connected in any phase is all that is required to determine the current.

It is well, however, to occasionally test all three phases with a portable ammeter, to locate any possible unbalance which may occur due to faulty machine windings; or to locate unbalance which may occur on main wires by connecting more single-phase equipment on some one phase than on another.

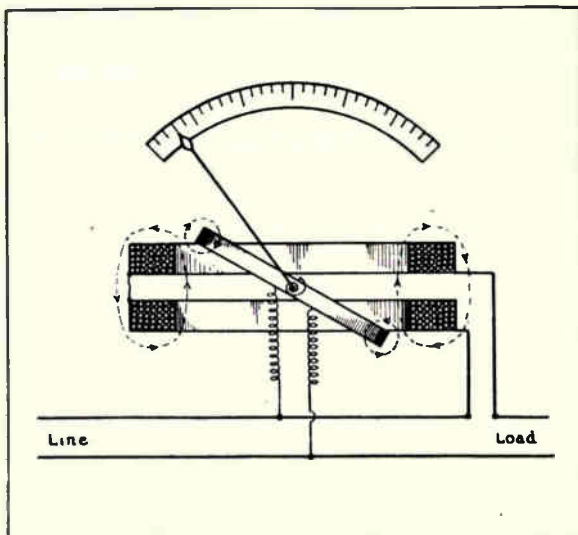


Fig. 11-6

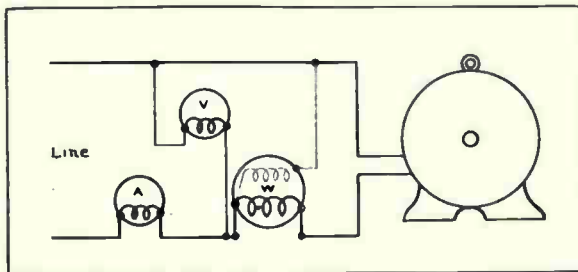


Fig. 11-7

### Three-phase Circuits, Voltage Measurements

Fig. 11-10 shows the method of connecting a voltmeter to indicate the voltage of a three-phase system

## METERS AND MEASUREMENTS

or motor. The voltmeter can be connected between any two of the three wires, and should show approximately the same reading on all phases.

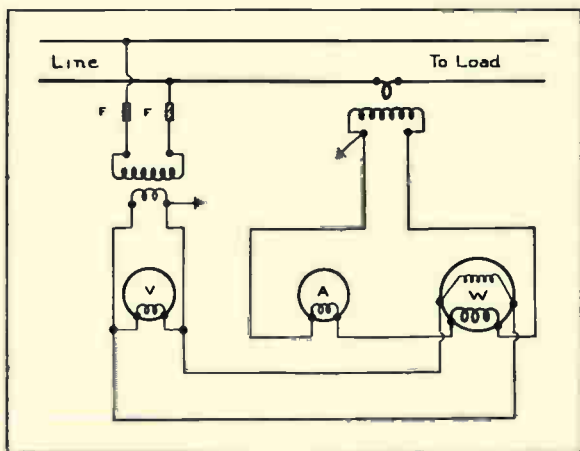


Fig. 11-8

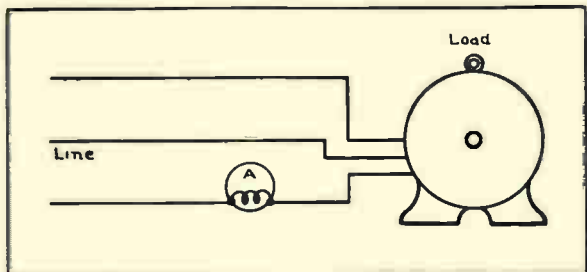


Fig. 11-9

Slight variations of voltage between the various phases generally do no harm, but if the voltmeter shows widely varying readings when connected first at X, then at Y, and then at Z, it indicates that the circuit is probably unbalanced.

### Three-phase Circuits, Power Measurements

For measuring the power of three-phase circuits, either single-phase or polyphase wattmeters can be used. The readings of single-phase wattmeters can be totalled to obtain the three-phase power, while a three-phase wattmeter will read directly the true power of all three phases.

## METERS AND MEASUREMENTS

Where single-phase wattmeters are used, the **two wattmeter method** shown in Fig. 11-11 is very commonly applied.

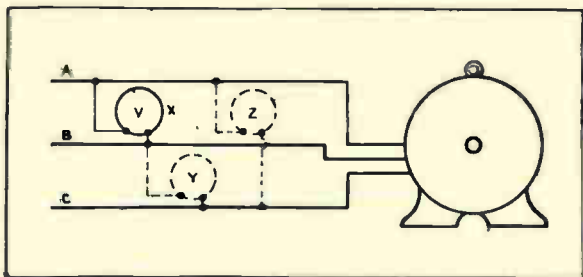


Fig. 11-10

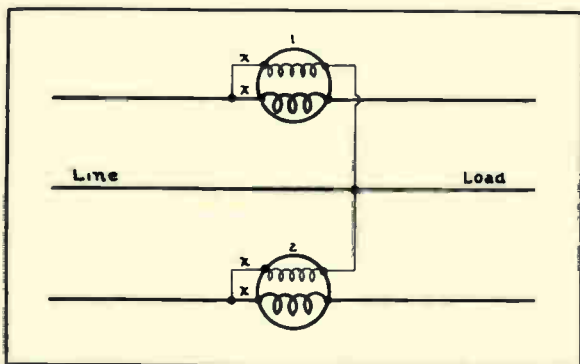


Fig. 11-11

In order to obtain correct results with the two meters, it is necessary to test them to make sure that corresponding coil leads are brought out to the same meter terminals; or, if they are not, to get them correctly marked so that the meters can be connected properly to the three-phase wires to get the right polarity of the meter coils.

To test the meters, connect them both to a single-phase circuit, or to the same phase of a three-phase circuit, as shown in Fig. 11-12 at A. Make sure that there is some load on the circuit to enable the meters to show a reading.

If both meters give the same indication with their pointers moving across the scale in the right direction, then carefully mark or tag the terminal of the



## METERS AND MEASUREMENTS

potential coil and the terminal of the current coil which are connected together and to the line. In this figure these leads are each shown marked with an "X"

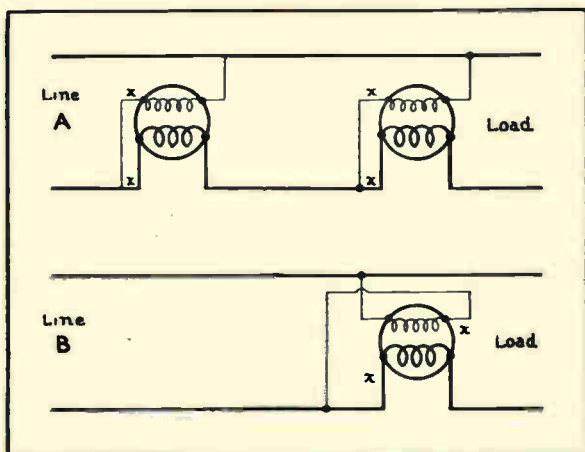


Fig. 11-12

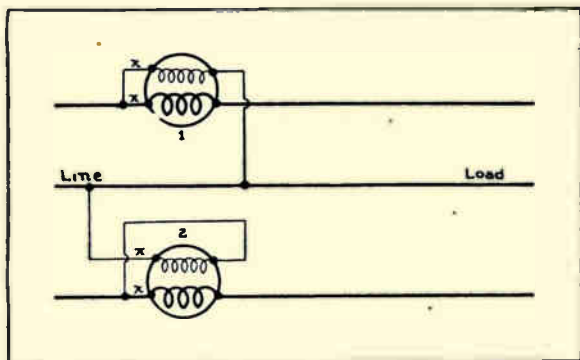


Fig. 11-13

If one of the meters reads "backwards" when connected as shown in Fig. 11-12 at A, the potential coil leads should be reversed as shown at B. The meter should then read "forward"; that is, its pointer should swing to the right across the scale. The terminals or leads should then be marked as shown.

## METERS AND MEASUREMENTS

With the two meters now connected to the three-phase circuit as shown in Fig. 11-11 and with the proper terminals connected together and to the lines, the meter readings will be called "positive" readings. The sum of the two meter readings will be the total three-phase power of the circuit. If the meters are properly connected as shown in Fig. 11-11 and the pointer of one meter attempts to swing backwards, or below zero, the potential leads of that meter should be reversed, as shown on meter No. 2 in Fig. 11-13. Its reading is then called "negative," and should be subtracted from that of the positive meter to get the three-phase power.

Fig. 11-14 shows the connections for the "two wattmeter method" of measuring three-phase power on high-voltage circuits where instrument transformers are used.

Separate potential transformers supply the voltage from the two phases to the potential elements of the wattmeters. Separate current transformers supply the proportional current from the two phases to the current elements of the two wattmeters.

The same procedure of marking the potential and current coil leads and checking the positive or negative readings is followed in this case as when no instrument transformers are used.

Fig. 11-15 shows three wattmeters used to measure the total power of a three-phase system.

With this connection we use a "Y box" which consists of three separate resistances, connected together at one end to form a star connection and provide a neutral point to which one end of each wattmeter potential coil is connected.

When connected in this way, each wattmeter measures only the power of the phase in which it is connected, and the total power will be the sum of the three meter readings.

For example, if meter No. 1 reads 14,000 watts, meter No. 2 reads 16,000 watts, and meter No. 3 reads 17,000 watts; the total power will be 47,000 watts.

Wattmeters connected in this manner will always read "positive" regardless of the power factor.

This makes the method very simple and reliable and one which is very commonly used on large power circuits, where very accurate readings are important and all chance of error should be avoided.

For measuring the total power of a three-phase, four-wire system, the connections shown in Fig. 11-16 are used. In these systems the neutral wire is already provided by the fourth wire which is connected to the star point of the windings of the alternator or at the transformer connections, and therefore no Y box is needed.

## METERS AND MEASUREMENTS

The total power of the three-phase, four-wire system thus measured will be the sum of the three meter readings.

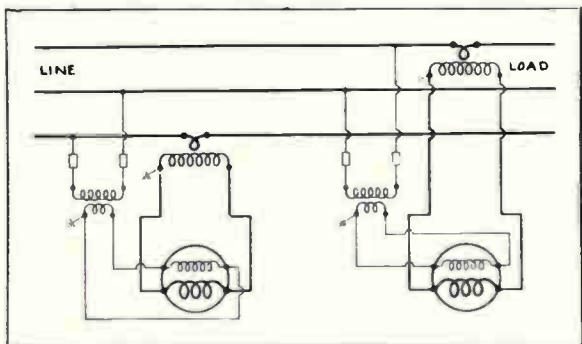


Fig. 11-14

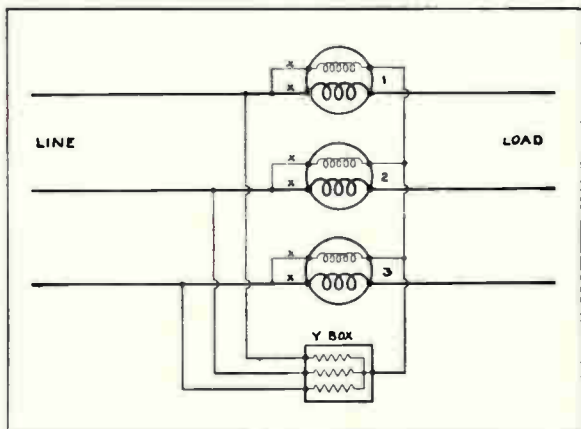


Fig. 11-15

## TESTING KILOWATT-HOUR METERS

Kilowatt-hour meters can be tested for accuracy, or calibrated, by comparison with standard portable test instruments.

A known load consisting of a resistance box can be connected to the load terminals of the meter when all other load is off. Then, by counting the revolutions per min. of the disk and comparing this number

## METERS AND MEASUREMENTS

with the revolutions made by the disk of a "rotating standard" test instrument, the accuracy of the meter can be determined.

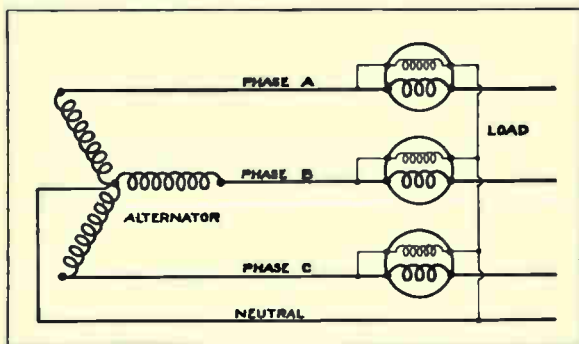


Fig. 11-16

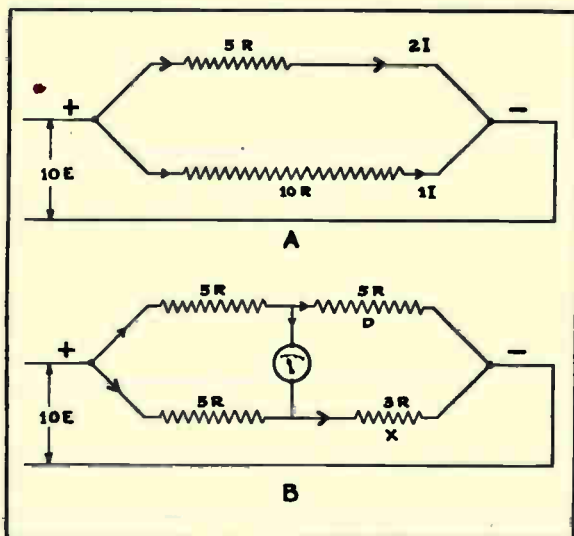


Fig. 11-17

When no standard load box or test instrument is available, a test can be conveniently made with a known load of several lamps or some device of which the wattage is known.

## METERS AND MEASUREMENTS

For this test the following formula should be used:

$$\frac{K \times 3600 \times T}{P} = \text{seconds}$$

In which:

K = the watt-hour constant marked on the meter disk.

3600 = number of seconds in an hour.

T = any chosen number of revolutions of the disk.

P = known load in watts which is connected to the meter.

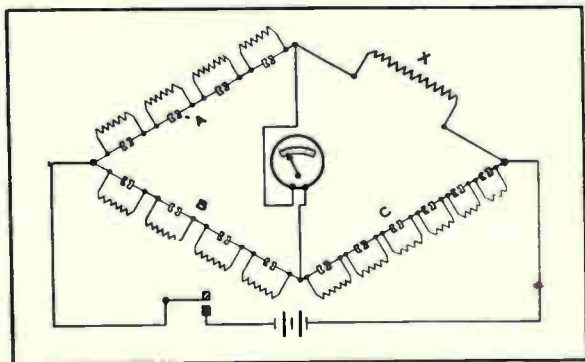


Fig. 11-18

For example, suppose we wish to test a meter which has a constant of .6, marked on its disk. We can connect a new 200-watt lamp, or two 100-watt lamps across the load terminals of the meter, after all other load has been disconnected. At the instant the lamp load is connected, start counting the revolutions of the meter and observe accurately the amount of time it requires to make a certain number of revolutions. Let us say it is 5 revolutions.

Then, according to the formula, the time required for the disk to make these 5 revolutions should be:

$$\frac{.6 \times 3600 \times 5}{200}, \text{ or } 54 \text{ seconds.}$$

If it actually requires longer than this, the meter is running too slow. If the time required to make the 5 revolutions is less than 54 sec., the meter is running too fast.

### WHEATSTONE BRIDGE

The principle of the Wheatstone Bridge, as used for measuring resistance, is shown by Fig. 11-17. In the

## METERS AND MEASUREMENTS

upper diagram, resistances of 5 ohms and 10 ohms are connected in parallel, and a potential difference of 10 volts is applied. The current divides, 2 amperes flowing through the 5-ohms resistance and 1 ampere through the 10-ohm resistance. In the lower diagram are four resistance coils; two coils of 5 ohms each in series with each other, and a 5-ohm coil and a 3-ohm coil in series with each other.

If we now connect a sensitive galvanometer across the center of the paths between the coils, as shown, it will indicate a flow of current from the upper path to the lower when voltage is applied to the terminals of the group.

Tracing from the positive terminal to the center of the group, the resistance of each path is equal, but from this point on to the negative terminal the lower path or coil "X" has the lower resistance. For this reason, some of the current tends to flow down through the galvanometer wire to the lower coil or easier path.

If we changed the coil "D" to one of 3 ohms, both sides of the circuit would again be balanced and no current would flow through the galvanometer.

On this same principle, if the resistance of coil "X" is not known, we can determine it by varying the resistance of coil "D" in known amounts until the galvanometer indicates zero, or a balanced circuit. We would then know that the resistance of coil "X" is equal to whatever amount of resistance we have in coil "D" to secure the balance.

### Operation of the Bridge

The Wheatstone Bridge operates on the same general principle just described. It consists of a box of resistance coils with convenient plugs for cutting coils of various resistance in and out of the balancing circuits.

Some bridges have knobs and dial switches instead of plugs for switching the resistance units; and some have the galvanometer built in the top of the box, and the dry cells inside.

Fig. 11-18 shows a diagram of a common type of bridge and the method by which the coils can be left in the various circuits or shorted out by inserting metal plugs in the round holes between metal blocks attached to the ends of each resistance coil.

The coil or line of which the resistance is to be measured is connected at X. The circuits A, B, and C are called **Bridge Arms**. A and B are called **Ratio Arms**, or **balanced arms**; and C is called the **Rheostat Arm**.

## METERS AND MEASUREMENTS

Arms A and B usually have the same number of resistor units of similar values in ohms. Arm C has a number of resistors of different values.

When the unknown resistance, X, has been connected in and the bridge arms so balanced that the galvanometer shows no reading when the button is pressed, the resistance of X in ohms can be determined by the use of the following formula:

$$X = \frac{A}{B} \times C$$

In which:

X = resistance in ohms of device under test.

A = known resistance in ratio arm A.

B = known resistance in ratio arm B.

C = known resistance in rheostat arm C.

## Section 12

# TRANSFORMERS

### DEFINITIONS

**Transformer.** A device usually consisting of two insulated windings on a common iron or steel core, in which alternating current supplied to one winding (the primary) induces by electromagnetic induction alternating emf's in the other winding (the secondary) and will produce alternating currents in a conductive circuit connected to the secondary winding. The voltage from the secondary may be higher or lower than that furnished to the primary winding.

**Step-Down Transformer.** A transformer in which the secondary winding has fewer turns than the primary, so that the secondary delivers a lower voltage than is supplied to the primary.

**Step-Up Transformer.** A transformer in which the secondary winding has more turns than the primary, so that the secondary delivers a higher voltage than is applied to the primary.

**Primary Winding.** The input winding of a transformer. Power line alternating current or pulsating d.c. is sent through this winding.

**Secondary Winding.** Any coil or winding of a transformer which is connected to the load, a coil from which power leaves the transformer.

**Iron-Core Transformer.** A transformer in which iron makes up part or all of the path for magnetic lines of force traveling through the transformer windings.

**Auto-Transformer.** A transformer in which part of the primary winding serves also as the secondary, or in which part of the secondary winding is also in the primary circuit. Part of the energy in the secondary comes directly from the primary through a conductive connection between the two.

### TRANSFORMER PRINCIPLES

It is a fundamental rule that in any transformer the amount of voltage change, or the ratio between the primary and secondary voltages, will be proportional to the ratio between the number of turns in the primary and secondary windings.

For example, if the primary winding of the transformer shown in Fig. 12-1 has fifty turns and the secondary winding has one hundred turns, the transformer will be a step-up transformer with a ratio of one to two.



## TRANSFORMERS

The first figure of a transformer ratio always refers to the primary and the second figure to the proportional number of turns in the secondary.

If, in another case, we have a step down transformer with a primary winding of 1000 turns and a secondary winding of 100 turns, the ratio of this transformer would be expressed as 10:1; and if we were to apply 2200 volts to the primary winding, 220 volts would be produced by the secondary winding.

From these illustrations we can see that the following formula applies:

$$\frac{\text{Primary voltage}}{\text{Secondary voltage}} = \frac{\text{Secondary turns}}{\text{Primary turns}}$$

or, in the case of the transformer just mentioned.

$$\frac{1000}{100} = \frac{2200}{220}, \text{ or } \frac{10}{1} = 10:1$$

If we know the ratio between the number of turns on the primary and secondary windings of any transformer and know the amount of primary voltage which is applied, we can easily determine the secondary voltage, because it will bear the same relation to the primary voltage as the number of secondary turns bears to the number of primary turns.

### Voltages and Turns in Windings

When  $E_p$  = primary volts

When  $E_s$  = secondary volts

When  $I_p$  = primary amperes

When  $I_s$  = secondary amperes

When  $T_p$  = primary turns

When  $T_s$  = secondary turns

$$E_p \times I_p = E_s \times I_s \qquad \frac{I_s}{I_p} = \frac{T_p}{T_s}$$

$$E_s = E_p \times \frac{T_s}{T_p} \qquad E_p = E_s \times \frac{T_p}{T_s}$$

$$I_s = I_p \times \frac{T_p}{T_s} \qquad I_p = I_s \times \frac{T_s}{T_p}$$

## TRANSFORMERS

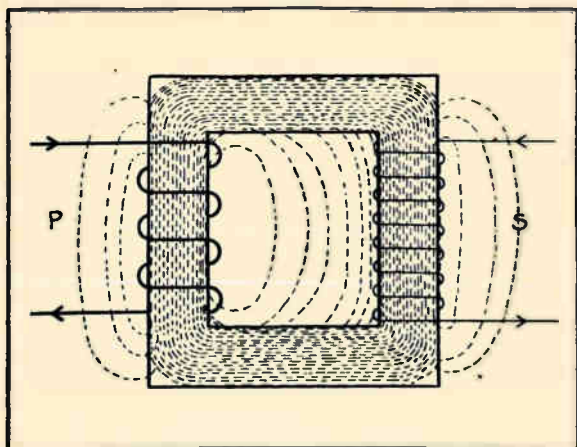


Fig. 12-1

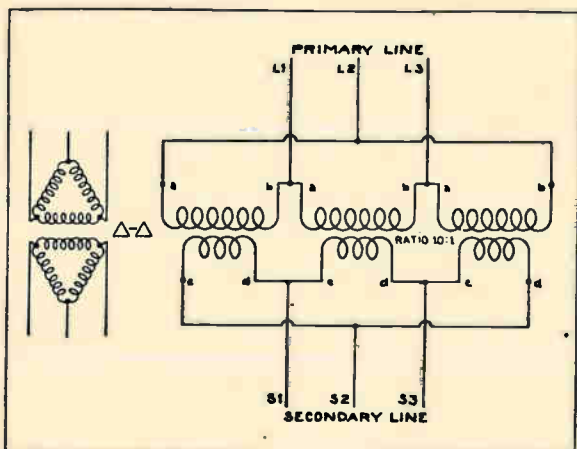


Fig. 12-2

### Power Output

If a transformer were 100% efficient, the amount of power in kv-a. that would be obtained from the secondary would always be the same as that supplied to the primary, regardless of the amount that the voltage might be stepped up or down.

## TRANSFORMERS

Of course, no transformer can be 100% efficient, but the efficiency of large power transformers is so high that for simple illustrative problems we may ignore the slight loss.

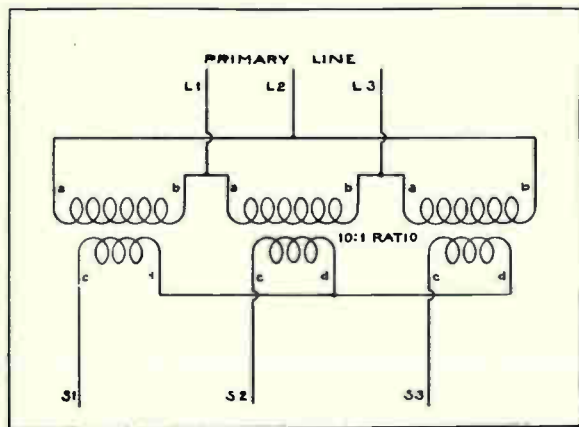


Fig. 12-3

If a step-up transformer produces a secondary voltage ten times as high as the voltage applied to the primary, then the full load current in the secondary winding will be just one-tenth of that in the primary winding.

For example, if a 10 kv-a. transformer with a ratio of 1 to 10 has 200 volts and 50 amperes applied to its primary and increases the voltage to ten times higher, or 2000 volts on the secondary, the full load secondary current will then be 5 amperes.

If we multiply the volts by the amperes in each case, we will find the same number of volt-amperes or kv-a. in the secondary as in the primary. The primary voltage times primary current will be:

$$200 \times 50 = 10,000 \text{ volt-amperes, or } 10 \text{ kv-a.}$$

The secondary volts times the secondary amperes will be:

$$2000 \times 50 = 10,000 \text{ volt-amperes, or } 10 \text{ kv-a.}$$

as before.

If the power factor of a transformer were 100%, we could obtain the same number of actual kw. of true power as the kv-a. rating of the transformer. However, the power factor of a transformer and its at-

## TRANSFORMERS

tached load is usually much lower than 100%, so it is often possible to have a 10 kv-a. transformer fully loaded and yet supplying only 5 to 8 kw.

This is the reason transformer capacity is always rated in kv-a.

### Transformer Regulation

The ratio of the drop in voltage between no load and rated load to the voltage at rated load. The per cent regulation is equal to,

$$\frac{\text{volts at no load} - \text{volts at rated load}}{\text{volts at rated load}} \times 100$$

### Fundamental Transformer Formula

$$\text{volts} = \frac{4.44 \times \text{cycles} \times \text{turns} \times \text{core area} \times \text{flux}}{100,000,000}$$

$$\text{core area} = \frac{100,000,000 \times \text{volts}}{4.44 \times \text{cycles} \times \text{turns} \times \text{flux}}$$

$$\text{turns} = \frac{100,000,000 \times \text{volts}}{4.44 \times \text{cycles} \times \text{core area} \times \text{flux}}$$

where volts, across terminals of winding  
cycles, operating frequency  
turns, of winding being considered  
core area, cross section in sq. inches  
flux, density in lines per sq. inch

**Example:** What should be the core area with a 200-volt secondary winding of 500 turns operating at 60 cycles, allowing 60,000 lines maximum flux density?

$$\frac{\text{core area}}{\text{area}} = \frac{100,000,000 \times 200}{4.44 \times 60 \times 500 \times 60000} = 2.5 \text{ sq. inches}$$

**Example:** How many turns should be used for a 120-volt winding for a 25-cycle transformer having a core 1.5 inches square (2.25 sq. in. area) operating at 75,000 lines maximum flux density?

$$\text{turns} = \frac{100,000,000 \times 120}{4.44 \times 25 \times 2.25 \times 75000} = 641 \text{ turns}$$

### Auto-Transformers

The entire winding forms the high-voltage winding. The low voltage winding is the portion between the tap and end to which both the primary and secondary line connections are made.

## TRANSFORMERS

Current in the low-voltage portion of the winding is equal only to the difference between primary and secondary line currents.

When  $I_l$  is current, amps., in low-voltage section.  
 $I_h$  is current, amps., in high-voltage winding.  
 $E_l$  is voltage across the low-voltage section.  
 $E_h$  is voltage across the high-voltage winding.  
 $T_l$  is turns in the low-voltage section.  
 $T_h$  is turns in entire (high-voltage) winding.

$$I_l = I_h \times \frac{T_h - T_l}{T_l} \quad E_l = E_h \times \frac{T_l}{T_h}$$

### THREE-PHASE TRANSFORMERS

In three-phase transformers there are three windings or coils on the primary side and three more on the secondary side. Three coils may be connected in delta or in star. Either the delta or the star connection may be used for either the primary or the secondary, so we have four variations:

Primary	delta	Secondary	delta	See	Fig. 12-2
"	delta	"	star	"	Fig. 12-3
"	star	"	delta	"	Fig. 12-4
"	star	"	star	"	Fig. 12-5

When  $E$  is the line (primary) voltage  
 $N$  is the ratio of turns in the windings  
and coils in each winding are connected as below, the secondary voltages are as shown.

Primary Coils Connected In	Secondary Coils Connected In	Secondary Voltage Is
delta	delta	$E \times N$
delta	star	$1.73 \times E \times N$
star	delta	$0.577 \times E \times N$
star	star	$E \times N$

Currents and voltages in the line conductors and in the coils are as follows:

When  $I_w$  is winding current, amps.  
 $I_l$  is line current, amps.  
 $E_w$  is winding voltage at terminals  
 $E_l$  is line voltage

# TRANSFORMERS

	Connected Star	Connected Delta
Current, amps., in each winding or coil.....	= $I_l$	$0.577 \times I_l$
Current, amps., in each line .....	= $I_w$	$1.73 \times I_w$
Voltage across each winding .....	= $0.577 \times E_l$	$E_l$
Voltage between each pair of line conductors.....	= $1.73 \times E_w$	$E_w$

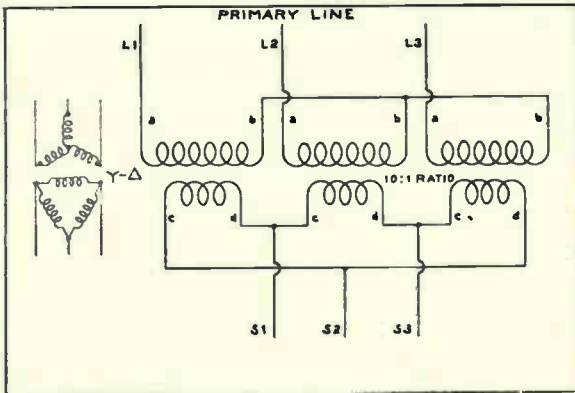


Fig. 12-4

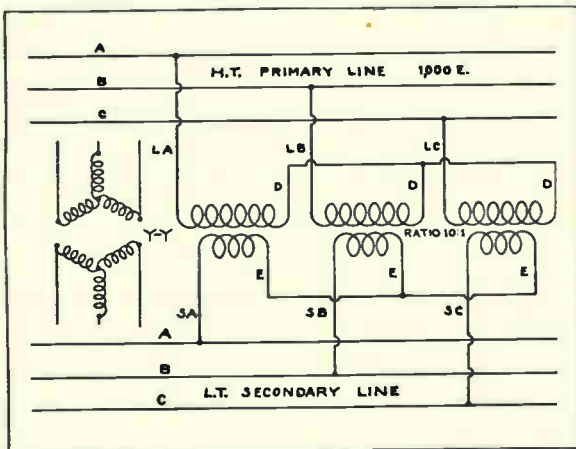


Fig. 12-5

## TRANSFORMERS

### POLARITY MARKINGS

Nearly all modern transformers have their leads marked with **polarity markings**. These marks would be for example: H-1 and H-2 on the high-tension side of a single-phase transformer, and X-1 and X-2 on the low tension side. See Fig. 12-6.

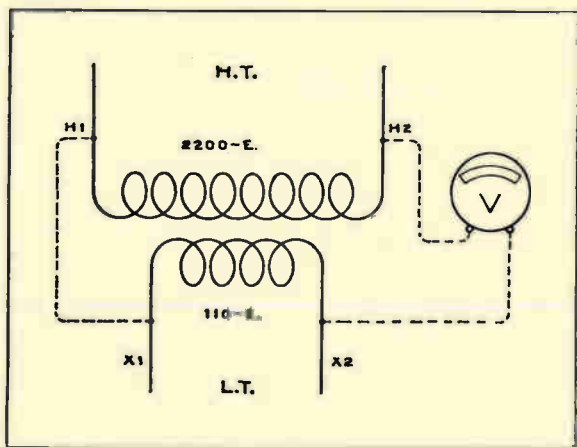


Fig. 12-6

On a three-phase transformer, the leads would be marked H-1, H-2, and H-3 on the high-tension side; and X-1, X-2, and X-3 on the low-tension side. These polarity markings indicate the order in which the leads are brought out from the windings, and also indicate the respective polarities of primary and secondary leads at any instant.

The polarity of alternating-current windings is continually and rapidly reversing; but, as the secondary always reverses with the same frequency as the primary and is always  $180^\circ$  out of phase with the primary, we can determine the respective polarities at any instant of any alternation.

The polarity markings aid in making the proper connections for transformers to be operated in parallel, as it is necessary to have similar leads connected together, in order to have the transformers operate with the proper phase relations for satisfactory parallel operation. Such connections are shown by Fig. 12-7.

## TRANSFORMERS

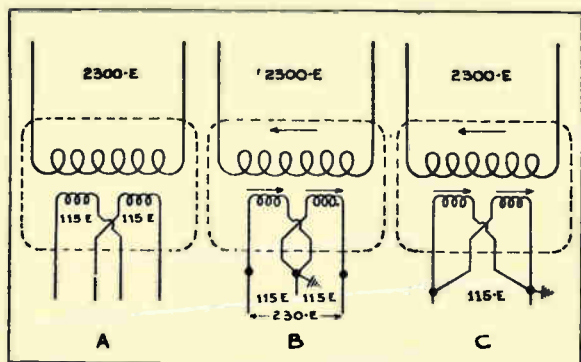


Fig. 12-7 A shows a single-phase transformer with the secondary winding in two sections. Note the manner in which the leads are crossed inside of the tank. B, Secondary windings connected for 115 and 230-volt service. C, Secondary windings connected in parallel for 115-volt service.

The highest and lowest numbers are placed at the end-leads or full winding, while the intervening numbers are placed on the part-voltage taps. The H-1 lead is usually located on the right-hand side, when facing the high tension side of the transformer. With transformers marked in this manner, if the H-1 and X-1 leads are connected together, as shown by the dotted line in Fig. 12-6, then when the voltage is applied to the H.T. winding the voltage between the remaining X-2 and H-2 leads will be less than the full voltage of the high-voltage winding.

In Fig. 12-6 a voltmeter is shown connected across the H-2 and X-2 leads of the single-phase transformer. The reason its reading will be lower than the applied voltage on the primary winding is because the polarity of the low-voltage winding is opposite to that of the high-voltage winding, and the two voltages will therefore oppose each other; so that the voltmeter will read their difference; or  $2200 - 110$  equals 2090. A transformer with the leads arranged and marked in this manner is said to have subtractive polarity.

If the leads are brought out of a transformer so that the voltmeter when connected to the adjacent H and X leads, as shown in Fig. 12-6, reads the sum of the voltages of the high tension and low tension windings, then the transformer is said to have additive polarity. In this case the markings of the X-1 and X-2 leads would be reversed.

On transformers which have their leads properly marked, the markings indicate whether the leads are arranged for subtractive or additive polarity.



## TRANSFORMERS

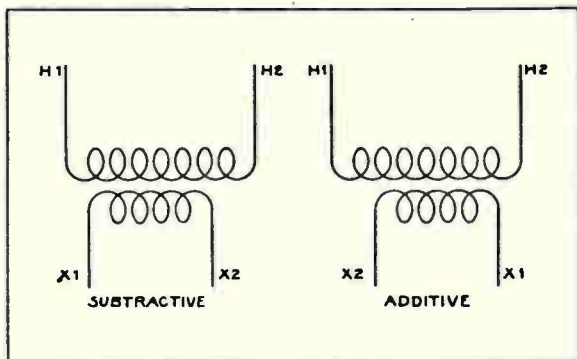


Fig. 12-8

Fig. 12-8 shows on the left a transformer with the leads marked for subtractive polarity and on the right another transformer with the leads marked for additive polarity.

When facing the high-tension side of a transformer, if the X-1 lead is on the right-hand side, it indicates that the polarity is subtractive; while, if the X-1 lead is on the left, it is then known to be additive polarity.

Leading transformer manufacturers have adopted standard connections and polarity markings for their transformers. Most power transformers are arranged with subtractive polarity, except distribution transformers of 200 kv-a. and under and with voltage ratings of 7500 volts and less; and these transformers are arranged with additive polarity.

### Testing the Polarity

When the leads of a transformer are not marked in any manner, we can determine whether it has additive or subtractive polarity by simply connecting a jumper between the high-tension and low-tension leads on one side and a voltmeter of the proper rating between the high-tension and low-tension leads on the other side, as shown in Fig. 12-6.

If, when the primary is excited with its rated voltage, the voltmeter reads the difference between the voltages of the high and low voltage windings, the transformer has subtractive polarity, and the leads should be marked as shown at the left in Fig. 12-8.

If the voltmeter reads the sum of the voltages of the high and low voltage windings, the transformer has additive polarity, and the leads should be marked as shown in the sketch at the right in Fig. 12-8.

## TRANSFORMERS

### STANDARD POLARITY MARKINGS

Following are extracts from rules relating to marking of transformer leads brought out of the case, as approved by the American Standards Association and sponsored by the National Electrical Manufacturers Association.

These rules specify the markings of leads brought out of the case but not the markings of winding terminals inside of the case, except that these terminals shall be marked with numbers in any manner which will permit of convenient reference and which cannot be confused with the markings of the leads brought out of the case.

It is recognized that special conditions will arise from time to time when these rules will not cover and which it would be very difficult to cover by any set of general rules.

In general the windings of a transformer shall be distinguished from one another by identifying them as Winding No. 1, Winding No. 2, Winding No. 3, etc. The highest voltage winding shall always be No. 1, except for three-phase to six-phase transformers.

The sequence of winding numbers after No. 1 may be by voltage or by kva.

In general the leads shall be distinguished from one another by marking each lead with a capital letter followed by a subscript number. The letters to be used are H for the leads of winding No. 1, X for the leads of winding No. 2, Y for the leads of winding No. 3, and Z for the leads of winding No. 4. The subscript numbers to be used are 1, 2, 3, etc.

A neutral lead shall be marked with the proper letter followed by subscript 0, e.g., H<sub>0</sub>, X<sub>0</sub>, etc.

A lead brought out from the middle of the winding for some other use than that of a neutral lead (e.g., a 50 percent starting tap) shall be marked as a tap lead.

#### Single-phase Transformers

The leads of any winding brought out of the case shall be numbered 1, 2, 3, 4, 5, etc., the lowest and highest numbers marking the full winding and the intermediate numbers marking fractions of winding or taps. All numbers shall be so applied that the potential difference from any lead having a lower number toward any lead having a higher number shall have the same sign at any instant. See Figs. 1, 2, 3, 4, 16 and 17 in this section.

If a winding is divided into two or more parts for series-parallel connections, and the leads of these parts are brought out of the case, the above rule shall apply for the series connection with the addition that the

## TRANSFORMERS

leads of each portion of the winding shall be given consecutive numbers. See Figs. 5 and 6 for four or more leads; Figs. 8, 9, 10, 11, 20 and 21 for two or three leads.

When two leads are brought out of the case through one bushing (to minimize inductive effect) the terminals shall be marked in accordance with Figs. 16 and 17. When in addition a lead must be brought out from the midpoint, for three-wire operation, the terminals shall be identified in accordance with Figs. 20 and 21.

The numbering of the leads of the H winding and the leads of the X winding shall be applied so that when  $H_1$  and  $X_1$  are connected together and voltage applied to transformer, the voltage between the highest numbered H lead and the highest numbered X lead shall be less than the voltage of the H winding.

To simplify the connections of transformers in parallel, the  $H_1$  lead shall be brought out on the right hand side facing the highest voltage side of the case and other H leads shall be brought out in numerical order from right to left.

When the high-voltage winding has only one terminal brought out through a rated voltage bushing (the other terminal to be grounded) the rated voltage terminal shall be designated as  $H_1$ . For polarity marking and testing, the  $H_1$  terminal shall be regarded as located on the right, regardless of its actual location. However, if two alternative positions are provided for the single rated voltage bushing, the two positions shall be identified by terminal markings in accordance with the preceding paragraph.

When the high-voltage terminals are brought out through two bushings of different insulation levels, the bushing having the higher voltage level shall be designated as  $H_1$  and shall be located on the right hand side facing the high-voltage side of the case. See Figs. 24 and 25.

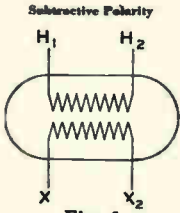
Figs. 26 and 27 illustrate the connection in multiple of single-phased transformers of additive polarity, of subtractive polarity, and of additive and subtractive polarity. These diagrams are included here as a matter of additional information.

### Three-phase Transformers

The three leads for each winding which connect to the full phase windings shall be marked  $H_1, H_2, H_3, X_1, X_2, X_3, Y_1, Y_2, Y_3$ , etc., respectively.

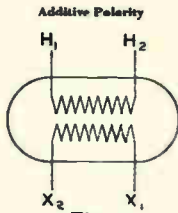
The markings shall be so applied that if the phase sequence of voltage on the highest voltage winding is in the time order,  $H_1, H_2, H_3$ , it will be in the time order of  $X_1, X_2, X_3$ , and  $Y_1, Y_2, Y_3$ , etc., on the other windings.

# TRANSFORMERS

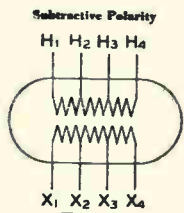


**Fig. 1**

Simple H and X Windings Without Taps

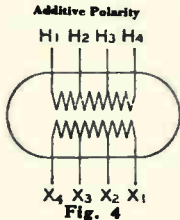


**Fig. 2**



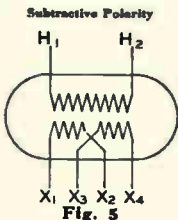
**Fig. 3**

Simple H and X Windings With Taps



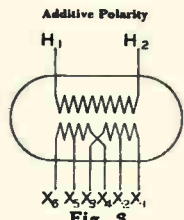
**Fig. 4**

Simple H and X Windings With Taps



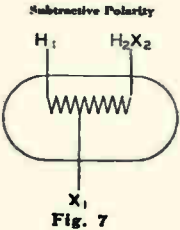
**Fig. 5**

Series Multiple X Winding Without Taps



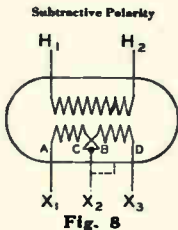
**Fig. 6**

Series Multiple X Winding With Taps



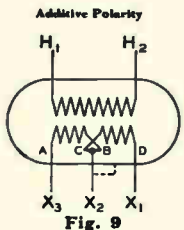
**Fig. 7**

Autotransformer

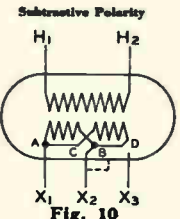


**Fig. 8**

Three-Wire Series Connection  
Transformers having neutral brought out between outside leads

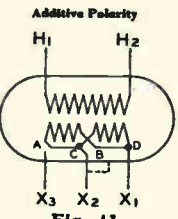


**Fig. 9**

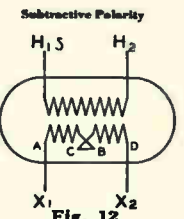


**Fig. 10**

Two-Wire Parallel Connection



**Fig. 11**

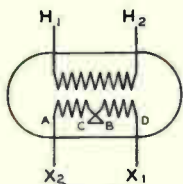


**Fig. 12**

Two-Wire Series Connection

# TRANSFORMERS

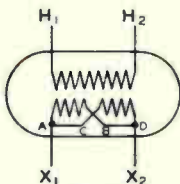
**Additive Polarity**



**Fig. 13**

**Two-Wire Series Connection**

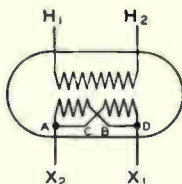
**Subtractive Polarity**



**Fig. 14**

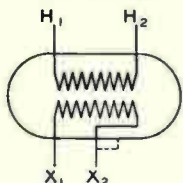
**Two-Wire Parallel Connection**

**Additive Polarity**



**Fig. 15**

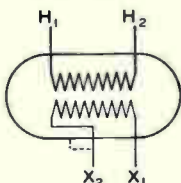
**Subtractive Polarity**



**Fig. 16**

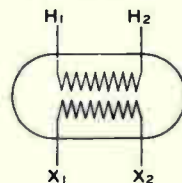
**120 Volt Class Connection**

**Additive Polarity**



**Fig. 17**

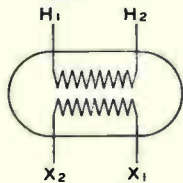
**Subtractive Polarity**



**Fig. 18**

**Above 120 Volt Class Connection**

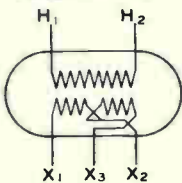
**Additive Polarity**



**Fig. 19**

**Above 120 Volt Class Connection**

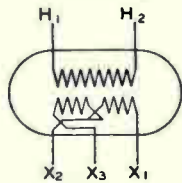
**Subtractive Polarity**



**Fig. 20**

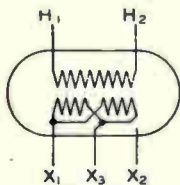
**Three-Wire Series Connection  
Transformers having neutral brought out to side**

**Additive Polarity**



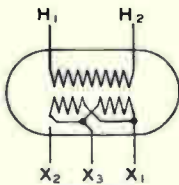
**Fig. 21**

**Subtractive Polarity**



**Fig. 22**

**Additive Polarity**

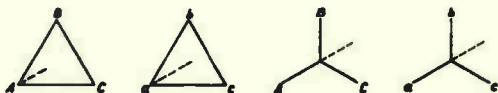


**Fig. 23**

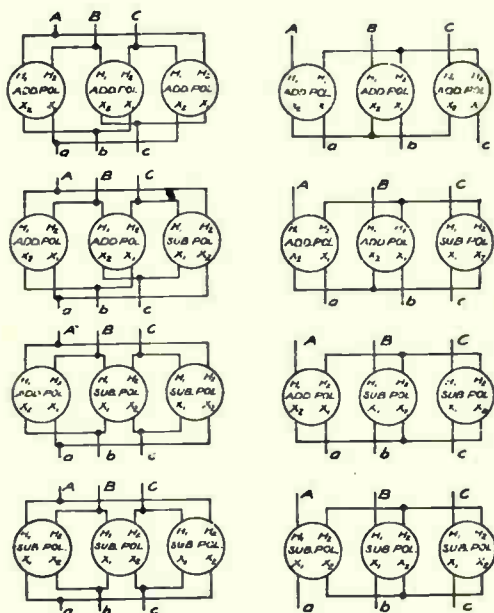
**Two-Wire Parallel Connection  
Transformers where neutral is brought out to side**

# TRANSFORMERS

## Angular Displacement and Connections—Single-Phase Transformers Connected Delta-Delta and Y-Y in Three-Phase Banks with $0^\circ$ Angular Displacement†



Dash lines show angular displacement between high and low voltage windings.



† NOTE—The above figures are included to illustrate connections of single-phase transformers of additive polarity, subtractive polarity, and additive and subtractive polarity in banks.

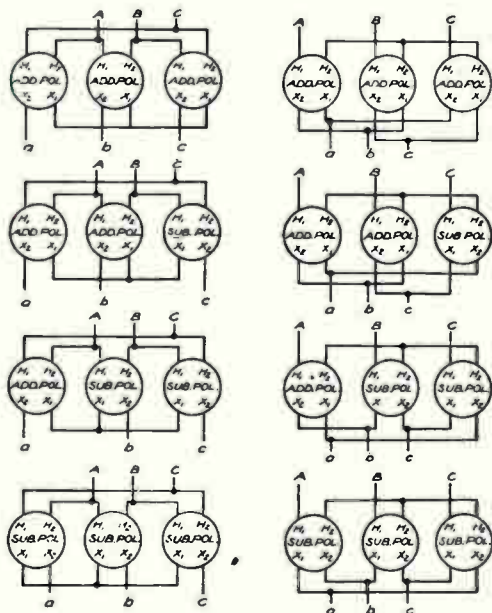
Fig. 24

## TRANSFORMERS

### Angular Displacement and Connections—Single-Phase Transformers Connected Delta-Y and Y-Delta in Three-Phase Banks with $30^\circ$ Angular Displacement†



Dash lines show angular displacement between high and low voltage windings.

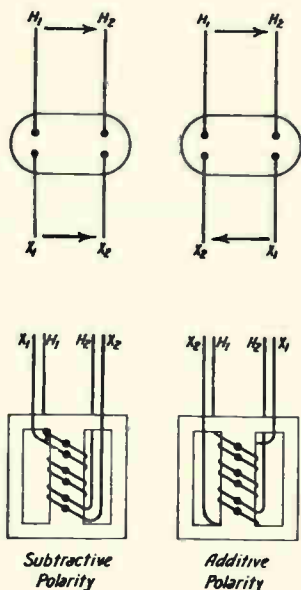


† NOTE—The above figures are included to illustrate connections of single-phase transformers of additive polarity, subtractive polarity, and additive and subtractive polarity in banks.

Fig. 25

## TRANSFORMERS

In order that the markings of lead connections between phases of three-phase transformers shall indicate definite phase relations, they shall be made in



**Fig. 26**

accordance with one of the three-phase groups shown in Figs. 28, 29 and 30. The angular displacement between the H winding and the X winding is the angle in each of the voltage vector diagrams between the lines passing from its neutral point through  $H_1$  and  $X_1$ , respectively.

Figs. 28 and 29 illustrate three-phase transformers without taps, while Fig. 29 illustrates transformers with taps. The broken lines or dashed lines show angular displacement between high-voltage and low-voltage windings.

When more than one low-voltage winding is used, the angular displacement between the H winding and each of the other low-voltage windings is established in the same manner, using  $H_1$  and  $Y_1$ ;  $H_1$  and  $Z_1$ ; etc., respectively.

Where tap leads are brought out of the case (neutral lead excepted) they shall be marked with the



# TRANSFORMERS

proper letter followed by the figures 4, 7, etc., for one phase, 5, 8, etc., for another phase, and 6, 9, etc., for the third phase. See Fig. 30.

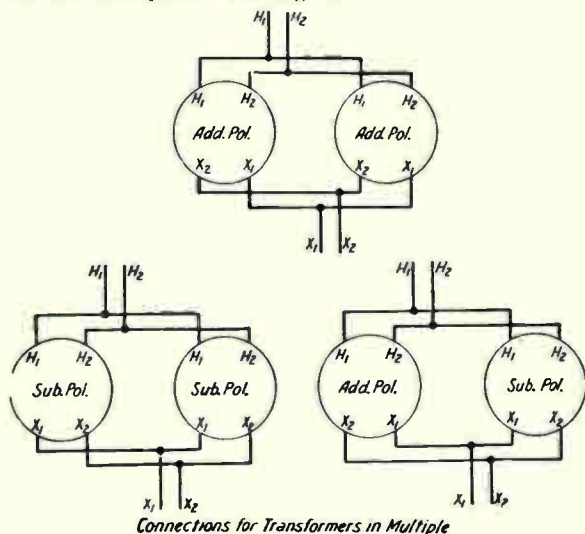
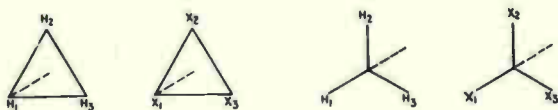
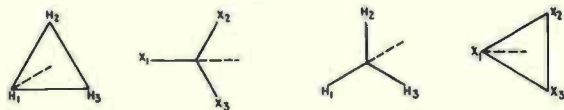


Fig. 27



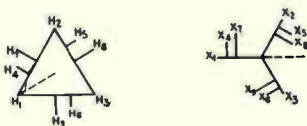
Group 1—Angular Displacement  $0^\circ$

Fig. 28



Group 2—Angular Displacement  $30^\circ$

Fig. 29



Group 3—Angular Displacement  $30^\circ$

Fig. 30

## TRANSFORMERS

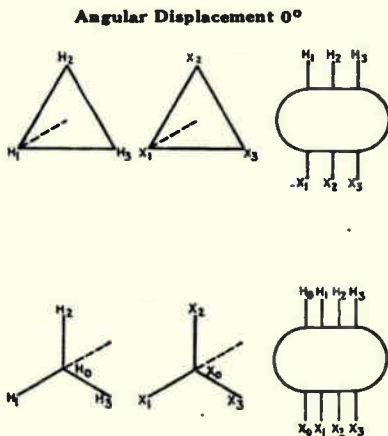
The order of numbering tap leads for a delta connection shall be as follows: 4, 7, etc., from lead 1 toward lead 2; 5, 8, etc., from lead 2 toward lead 3; and 6, 9, etc., from lead 3 toward lead 1.

The order of numbering tap leads for a star connection shall be as follows: 4, 7, etc., from lead 1 toward neutral; 5, 8, etc., from lead 2 toward neutral; and 6, 9, etc., from lead 3 toward neutral.

Transformers having leads marked in accordance with the foregoing rules may be operated in parallel by connecting similarly marked leads together, provided their angular displacements are the same and provided also their ratios, voltages, resistances, reactances and ground connections are such as to permit parallel operation.

In some cases designs may be such as to permit parallel operation although, due to a difference in the number of tap leads, the leads to be connected together are not similarly marked.

To simplify the work of connecting transformers in parallel, the  $H_1$  lead shall be brought out on the right hand side of the case facing the highest voltage side of the case. The  $H_2$  and  $H_3$  leads shall be brought out so that the three leads are arranged in numerical order reading from right to left when facing the highest voltage side of the case. The  $H_n$  lead, if present, will be located to right of the  $H_1$  lead when facing the highest voltage side of the case. See Figs. 31, 32 and 33.



**Fig. 31**

## TRANSFORMERS

The  $X_1$  lead shall be brought out on the left hand side of the case facing the X winding side of the case. The  $X_2$  and  $X_3$  leads shall be brought out so

### Angular Displacement $30^\circ$

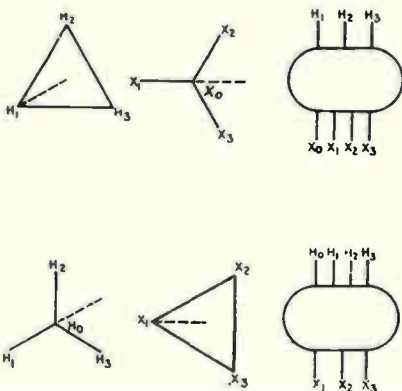


Fig. 32

### Autotransformers

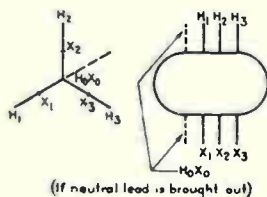


Fig. 33

that the three leads are arranged in numerical order reading from left to right when facing the X winding side of the case. The  $X_0$  lead, if present, will be located to the left of the  $X_1$  lead facing the X winding side of the tank.

The Y winding and Z winding leads, if present, shall be brought out and numbered in the same manner as the X winding leads.

The location of the external leads specified in the three preceding paragraphs shall apply to only one connection, such as a Y or a delta, of a given winding.

## TRANSFORMERS

Autotransformer leads shall, as far as practicable, be marked in accordance with the requirements for corresponding multi-winding transformers. See Fig. 33.

The dashed lines or broken lines in Figs. 31, 32 and 33 show angular displacement between high-voltage and low-voltage windings.

### TRANSFORMER INSTALLATION

Following are some of the general rules of the National Electrical Code which apply to transformers of types in common use. There are other special rules applying to transformers in hazardous locations, sign transformers, and X-ray or other high-frequency transformers. Radio transformers, relay and meter transformers, and transformers forming a part of other apparatus ordinarily conform to rules governing the construction of such apparatus.

**Transformers of All Voltages.** In buildings other than generating stations and sub-stations, transformers, except potential instrument transformers, shall comply with the following:

**Air-Cooled Transformers.** Transformers whose windings are cooled by exposure to the air shall have a separation of at least 12 inches from combustible material, unless separated therefrom by a barrier of incombustible heat-insulating material, or unless of rating not exceeding 600 volts and completely enclosed except for ventilating openings. An air space of at least six inches shall be left between transformers and between each transformer and adjacent surfaces, except the surface upon which it is mounted.

**Liquid That Will Not Burn.** A transformer immersed in an approved liquid that will not burn and rated in excess of 25 kva shall be furnished with a pressure-relief vent. If installed in a poorly ventilated place inside of a building it shall also comply with one of the following conditions:

It shall be furnished with a means for absorbing any gases generated by arcing inside the case, or

The pressure-relief vent shall be connected to a chimney or flue which will carry such gases outside the building.

**Liquid That Will Burn.** Transformers immersed in a liquid that will burn shall be installed in a vault, except by special permission as follows:

Transformers rated at not more than 600 volts and 10 kva may be installed without a vault in a building or room of other than fire-resistive construction, if there is no combustible material in the vicinity of the transformer.

## TRANSFORMERS

Transformers rated at not more than 600 volts and not more than 25 kva in any one unit, or not more than 75 kva total rating, may be installed without a vault in a building or room of fire-resistive construction and containing no other combustible material in the vicinity of the transformer, if surrounded by concrete curbs not less than 6 inches high forming a basin of sufficient capacity to retain all the liquid used in the transformers.

**Transformers Exceeding 600 Volts.** In buildings other than generating stations and sub-stations, transformers operating at more than 600 volts, except potential instrument transformers, shall comply with the preceding rules and also the following:

They shall be installed only by special permission.

They shall be located where the supply conductors enter the building or as near to this point as practicable.

Transformers immersed in a liquid that will burn shall comply with preceding rules for such liquid. Other transformers shall be installed so as to provide mechanical protection, ventilation, and inaccessibility to unauthorized persons. If exceeding 15,000 volts between terminals they shall be installed only in a vault conforming to special rules.

In electric furnace rooms transformers immersed in a liquid that will burn, with total rating not exceeding 75 kva, may be installed in accordance with preceding rules for liquid that will burn.

**Transformers Attached to or Adjacent to Building.** Transformers attached to the exterior of a building or in immediate proximity thereto shall be so located as not to interfere with the raising of fire ladders; shall be at least 4 feet from fire escapes and outside stairways; and shall comply with the following:

If immersed in a liquid that will burn, they shall be placed against a blank wall of masonry or reinforced concrete. They shall not be directly under any combustible eaves or cornices.

It is recommended that wall openings within 10 feet be protected by standard fire doors or shutters. Under some circumstances openings distant more than 10 feet should be protected.

If immersed in a liquid that will not burn, there shall be an air space of at least 6 inches between the transformer case and any adjacent combustible material.

If transformers immersed in a liquid that will burn are placed under a sidewalk in front of a building they shall be located in a vault complying with special rules.

## TRANSFORMERS

**Transformers Mounted on Roofs.** A transformer installed on the roof of a building shall comply with the following:

If the transformer is immersed in a liquid that will burn, it shall be installed in a vault.

A transformer immersed in a liquid that will not burn shall be mounted well away from doors. If located so that leaking liquid might reach a window or door, it shall be mounted on a metal pan or concrete basin large enough to retain the liquid.

**Auto-Transformers.** Transformers in which a part of the turns are common to both primary and secondary alternating-current circuits, ordinarily known as auto-transformers, may be connected to an interior wiring system only under one of the following circumstances:

The system supplied contains an identified grounded conductor which is solidly connected to a similar identified grounded conductor of the system supplying the auto-transformer.

The auto-transformer is used for starting or controlling an induction motor and may be included in a starter case or installed as a separate unit.

The auto-transformer supplies a circuit wholly within apparatus which also contains the auto-transformer.

The auto-transformer is used for fixed voltage adjustment on an existing power circuit having no identified grounded conductor.

### Overcurrent Protection

**Operating at 600 Volts or Less.** If located inside building, each transformer or bank of transformers operating as a unit, except instrument transformers, shall be separately protected on the primary side by an automatic overcurrent device rated or set at not more than 200 per cent of the full-load current rating of the transformer or bank of transformers. Potential instrument transformers should be protected in the primary circuit by fuses rated at not more than 5 amperes.

### Grounding

Transformer cases shall be grounded except:

Cases or frames of transformers used exclusively to supply current to switchboard instruments or protective relays, if they are installed and guarded as required for the maximum potential at which they operate.

Transformers mounted on wooden poles at a height of more than 8 feet from the ground.

## Section 13

### MOTORS

#### DEFINITIONS

**Motor.** A rotating electric machine which changes applied electrical energy or power into mechanical output energy or power.

**Generator.** A rotating electric machine which changes applied mechanical driving energy or power into direct-current or alternating-current output energy or power.

**Alternator.** A generator of alternating current; usually a synchronous alternating-current generator.

**Field Magnet.** The permanent magnet or electromagnet which supplies a magnetic field in a generator, motor or other electrical equipment.

**Pole.** That portion of the magnetic circuit of a motor or generator around which the field windings or stator windings are wound. The poles confine the magnetic flux to given locations within the motor or generator.

**Armature.** Usually the movable portion of a magnetic circuit, such as the rotating section of a generator or motor.

**Commutator.** A ring of insulated copper segments on which bear the contact brushes. A generator commutator changes the generated alternating currents into direct currents for the line. A motor commutator changes the direction of applied direct current so that currents flow in an armature or rotor as required for the necessary magnetic effects.

**Brush.** A stationary conductor held in contact with a moving conductor or conductors to allow flow of current between stationary and moving parts of electrical equipment.

**Rotor.** In a generator, motor or other electric machine having a rotating member, the member that rotates. A word used chiefly when referring to alternating-current machines.

**Stator.** The parts of an alternating-current motor or generator on which are the stationary windings.

**Collector Rings.** Continuous metallic rings on a rotating member, against which bear stationary brushes to allow current flow between the rotating and stationary parts of the equipment.

**Torque.** Turning effort. The effect of a force that tends to cause rotation of parts about a center. An electric motor exerts torque at its shaft when supplied with current, and if the torque is sufficiently great it will cause the shaft to rotate.

## MOTORS

**Slip.** The difference between synchronous speed of an induction motor and the speed at which the motor actually runs.

**Shunt Winding.** In a motor, generator or other electric machine, a winding through which flows only a portion of the total current entering or leaving the machine; a winding which is in parallel with the armature windings.

**Shunt-Wound Motor.** A direct-current motor having its field windings connected in parallel or shunt with its armature, and with the paralleled field and armature connected across the line supply.

**Series Winding.** In a motor, generator or other electric machine, a winding in which flows all the current that enters or leaves the machine.

**Series-Wound Motor.** A direct-current motor having its field windings connected in series with its armature, and the field and armature in series with the line so that all current flowing through the field flows also through the armature.

**Universal Motor.** A series-wound motor, with commutator and brushes, which will run on either alternating or direct current.

**Compound-Wound Motor.** A direct-current motor, part of whose field windings are in parallel with or shunted across the armature while the other part of the field windings are in series with the armature. Having both shunt and series field windings.

**Induction Motor.** An alternating-current motor in which energy from stationary windings is transferred to conductors on the revolving rotor by electromagnetic induction, and in which the rotor receives no current through any conductive connections such as brushes and a commutator or slip rings.

**Split-Phase Motor.** An alternating-current induction motor which is made self-starting on single-phase current by using two stator windings, in one of which the current is displaced in phase with reference to that in the other winding to produce a rotating field somewhat like the rotating field secured from two-phase current.

**Capacitor Motor.** A split-phase motor in which a capacitor or capacitors displace part of the current in phase from the remainder in order that the motor may be self-starting on single-phase supply current.

**Shaded Pole Motor.** An alternating-current induction motor which is self-starting on single-phase current supply because of a partial displacement of magnetic lines or flux at the field poles through auxiliary currents and flux produced in closed conductive rings around parts of the pole tips.



## MOTORS

**Polyphase Motors.** Any motors which operate from a supply of more than one phase; from a 2-phase or 3-phase supply.

**Squirrel Cage Motor.** An alternating-current induction motor in which the conductors on the rotor consist of bars parallel to the rotor axis or shaft, joined together at the front and rear of the armature by conductive rings. The conductors, neglecting their supports, would have the general form of a squirrel cage.

**Wound Rotor Motor.** An induction motor on whose rotor are wire windings connected to slip rings which rotate with the rotor shaft and on which bear brushes. External adjustable resistors are connected to the rotor windings through the rings and brushes. The resistors permit adjustment of motor speed.

**Slip Ring Motor.** A wound rotor motor.

**Repulsion-Start Induction Motor.** A type of alternating current motor that starts as a repulsion motor and runs as an induction motor, the changeover being made by an automatic switch, usually within the motor.

**Repulsion-Induction Motor.** An alternating-current motor with two rotor windings; one of which may be a squirrel cage or modified squirrel cage, while the other is similar to that of the repulsion-start induction motor. The commutator and brushes are used during starting, but practically no current flows through them at full speed.

**Synchronous.** Happening at the same time; having the same alternating phase relations and period; maintaining a frequency exactly proportional to operating speed, or a speed exactly proportional to supply frequency.

**Synchronous Motor.** An alternating-current motor which runs at a speed exactly proportional to the frequency of the supply current. There is no slip in a synchronous motor.

**Synchronous Speed.** The synchronous speed of an alternating-current motor depends on the supply frequency and on the number of motor poles, as follows:

$$\text{Synchronous Speed, RPM} = \frac{120 \times \text{frequency, cycles}}{\text{number of poles}}$$

## MOTOR TYPES AND CHARACTERISTICS

### Single-Phase A-C Motors

**Split-Phase Motors.** The split-phase motor has two stator windings. In the circuit of one winding there is more inductance, more resistance, or more capacitance than in the circuit of the other. Consequently

## MOTORS

the phase of currents in one winding is displaced with reference to that of currents in the other windings. The phase displacement provides, in effect, two currents which produce a rotating field and drag the rotor around to start the motor on a single-phase supply.

Split-phase motors have rather low starting torque for the starting current used. They are not used on loads which come up to speed slowly. They have fairly good power factor and efficiency, also constant running speed.

Common uses are for fans and blowers, small pumps, grinders and small power tools, washing machines, ironers, and similar applications.

**Capacitor Motors.** All capacitor motors are split-phase types with a capacitor to provide phase displacement for starting. Capacitor-start motors have the capacitor cut out after starting, then run as a split-phase type. Capacitor-run motors use the same or another capacitor during the running period.

Capacitor motors may be designed for high, medium or low starting torque with normal starting current; depending on the service requirements. They may be designed also to allow a high slip. These motors, especially in capacitor-run types, have very good power factors and efficiencies. They run quietly.

Capacitor motors are commonly applied to fans, any centrifugal devices, pumps, domestic refrigerators, stoker drives, grinders and bench tools, mixers, presses, control devices, and wherever frequent starting is required.

**Shaded Pole Motors.** These motors provide phase displacement for starting by having closed circuit conductive rings or coils on a portion of the stator pole faces. They have very low starting torque and poor efficiency. They run at steady speed with steady load, but speed varies somewhat with load changes. The construction is very simple, there are no external connections to the rotor, operation is quiet, and stalling under load ordinarily does no damage. These motors are used chiefly for control apparatus, small fans, and wherever the need is for motion without much power.

**Repulsion-induction Motors.** These motors are suitable for starting very heavy loads. They will bring up to speed practically any load which they can start, and they maintain constant speed with a steady load.

Repulsion-induction motors are used for pumps which must start under load, for hoists and elevators, heavy duty grinders, saws, knives, cutters, and similar applications.

**Universal Motors.** These motors ordinarily are designed to operate, in small sizes, at speeds from 5,000

## MOTORS

to 10,000 rpm or more, and will race badly if under-loaded. They are applied to relatively constant loads, such as domestic and office appliances, and small portable tools. Starting torque is very high. Torque decreases as speed increases. The speed varies widely with changes of load, but stalling is unlikely.

**Synchronous Motors.** Small synchronous motors usually are of the split-phase or capacitor types, although very small sizes may be of the shaded pole type. Such motors have extended or salient poles on the rotors, so that they pull into synchronous speed soon after starting. Starting torque of split-phase and capacitor types is fairly good. There is some unavoidable vibration while running.

### Polyphase A-C Motors

**Squirrel Cage Motors.** Squirrel cage induction motors are generally used in all power ranges wherever three-phase or two-phase current is available. They are the simplest of any type in construction, deliver the greatest power for a given size, weight and speed, and need a minimum of maintenance. Squirrel cage motors operate at practically constant speeds on steady loads, and most types have but little speed variation with moderate changes of load. Adjustable speed induction motors have special forms of rotor construction.

Squirrel cage induction motors may be classified as follows in accordance with their starting torques and starting currents:

- A. Normal torque, normal (starting) current.
- B. Normal torque, low current.
- C. High torque, low current.
- D. High slip motors; having high starting torque, medium starting current, and two to four times the normal slip at full-load.
- E. Low torque, normal current.
- F. Low torque, low current.

High torque and high slip motors are used for starting heavy loads, such as compressors and pumps. Low torque types are used for loads which are light when started, such as fans and blowers. The high slip motor often is used with a flywheel which cares for high peaks of load.

**Wound Rotor Motors.** This type of motor is used for heavy starting duty, especially where there must be frequent starts. It is used also where running speed must be adjustable, and where the starting current must be low.

**Synchronous Motors.** These are used where running speed must be constant. They are especially suitable for low speeds, under 500 rpm. Synchronous motors will handle medium loads at starting.

## MOTORS

### Direct-Current Motors

**Series-wound Motors.** Series d-c motors will start the heaviest loads. Their running speed decreases as the load increases, and the speed rises at light loads. At very light loads, or at no load, the speed may become so high as to damage the motor. Maximum torque is limited only by the ability of the commutator and brushes to handle the large currents. Series motors are adapted to hoists and similar loads.

**Shunt-wound and Compound-wound.** Both of these types will maintain a nearly constant speed with fairly great changes of load. With both of them the speed may be adjusted either above or below normal running speeds, and will be closely maintained at the point of adjustment. The shunt-wound motor is suited for medium starting loads, while the compound-wound type will handle heavy starting duty. Compound-wound motors may be used on flywheel loads where there are high peaks at recurring intervals. Neither type will race at light loads, as will a series motor.

Applications of shunt and compound-wound d-c motors include machine tool drives, any machinery where close speed regulation and adjustable speed are needed, railroad and marine applications, and such work.

### REVERSING ROTATION OF MOTORS

**Basic Rule.** Extend the thumb, forefinger and middle finger of your left hand so that they are at right angles to one another, so that each is at a right angle to the other two. When your forefinger points in the direction of magnetic flux between poles and through the armature or rotor conductors, and when your middle finger points in the direction of current flow through the conductors, your thumb will point in the direction that the conductors are moved through the field.

**Split-phase Motors.** Reverse the connections to the starting winding, or reverse the connections to the running winding. Do not reverse the connections to both windings.

**Capacitor Motors.** Same as for split-phase motors.

**Shaded Pole Motors.** Reversible only when there are two sets of field windings, one set for each direction of rotation.

**Repulsion Motors.** Shift the position of the short-circuited brushes on the commutator.

**Induction-start, Synchronous-run Motors.** Shift the brush position on the commutator, and also interchange the connections to the two slip rings.





## MOTORS

### MOTOR CURRENTS AT FULL LOAD

Amperes

#### Single-Phase A.C. Motors

HP	110V	220V	440V
1/6*	3.34	1.67	—
1/4*	4.8	2.4	—
1/2*	7	3.5	—
3/4*	9.4	4.7	—
1*	11	5.5	—
1 1/2	15.2	7.6	—
2	20	10	—
3	28	14	—
5	46	23	—
7 1/2	68	34	17
10	86	43	21.5

These values of full-load current are for motors running at speeds usual for belted motors and motors with normal torque characteristics. Motors built for especially low speeds or high torques may require more running current, in which case the nameplate current rating should be used.

For full-load currents of 208 and 200 volt motors, increase the corresponding 220-volt motor full-load current by 6 and 10 per cent respectively.

#### Direct-Current Motors

HP	115V	230V	550V
1/2*	4.5	2.3	—
3/4*	6.5	3.3	1.4
1*	8.4	4.2	1.7
1 1/2	12.5	6.3	2.6
2	16.1	8.3	3.4
3	23.0	12.3	5.0
5	40	19.8	8.2
7 1/2	58	28.7	12.0
10	75	38	16.0
15	112	56	23.0
20	140	74	30
25	185	92	38
30	220	110	45
40	294	146	61
50	364	180	75
60	436	215	90
75	540	268	111
100	—	357	146
125	—	443	184
150	—	—	220
200	—	—	295

These current values are from the National Electrical Code. The values for full-load current are average for all speeds.

## MOTORS

Classification of Service	Percentages of Name-Plate Current Rating			Con- tinuous Rating
	5-Minute Rating	15- Minute Rating	30 & 60- Minute Rating	
<b>Short-Time Duty</b>				
Operating valves, raising or lowering rolls	110	120	150	-----
<b>Intermittent Duty</b>				
Freight and passenger elevators, tool heads, pumps, drawbridges, turntables, etc.	85	85	90	140
<b>Periodic Duty</b>				
Rolls, ore and coal-handling machines	85	90	95	140
Varying duty	110	120	150	200
	or lower at the discretion of the authorities enforcing the regulations.			

The conductors between stationary motors, rated  $\frac{1}{2}$  H. P. or less, and certain separate terminal enclosures permitted, may be smaller than No. 14 but not smaller than No. 18, provided they have current-carrying capacity as specified above.

The size of conductor calculated on the basis of 125 per cent of the motor full-load current for the more usual motor ratings is shown in the tables of "Motor Wiring and Overcurrent Protection."

For long runs, it may be necessary in order to avoid excessive voltage drop, to use conductors of sizes larger than the minimum sizes given in those tables.

**Conductors Supplying Several Motors.** Conductors supplying two or more motors shall have a current-carrying capacity of not less than 125 per cent of the full-load current rating of the highest rated motor in the group plus the sum of the full-load current ratings of the remainder of the motors in the group.

**Combination Load.** Conductors supplying a motor load, and in addition a lighting or appliance load, shall have a current-carrying capacity sufficient for the lighting or appliance load plus the required capacity for the motor load determined as above for several motors or for an individual motor, as the case may be.

### Motors of 1 H.P. or Less

#### One Horsepower or Less — Manually Started.

Motors of 1 horsepower or less which are manually started and which are in a location within sight of the operator, shall be considered as protected against overcurrent by the overcurrent device protecting the conductors of the branch circuit. This overcurrent device shall not be larger than that specified in the table of "Motor Wiring and Overcurrent Protection", except that such a motor may be used also at 125 volts or less on a branch circuit protected at 20 amperes. Any such motor which is in a



## MOTORS

location out of sight of the operator shall be protected as specified below for automatically-started motors.

**1/8 to One Horsepower — Automatically Started.** Motors of 1/8 to 1 horsepower inclusive which are started automatically shall be considered as protected against overcurrent under any of the following conditions:

1. If provided with overcurrent protection not greater than 140 per cent of the full-load current rating of the motor. The overcurrent protective device shall have sufficient time delay to permit the motor to start and accelerate its load.

2. If the motor is a type which cannot overheat due to overloads or failure to start.

This result may be secured by windings having a sufficiently high impedance to prevent overheating, or by the use of an approved protective device which is an integral part of the motor.

3. If part of an approved assembly which does not normally subject the motor to overloads and which is also equipped with other safety controls (such as the safety combustion controls of a domestic oil burner) which protect the motor against damage due to stalled rotor current. Where such protective equipment is used it shall be indicated on the name-plate of the assembly where it will be visible after installation.

**d. Less than 1/8 Horsepower—Automatically Started:** Motors of less than 1/8 horsepower, automatically started, shall be considered as protected against overcurrent by the overcurrent device protecting the conductors of the branch circuit.

### Grounding of Motors

**Stationary Motors.** The frames of stationary motors shall be grounded if any of the following conditions exist:

- a. If supplied by means of metal-clad wiring.
- b. If located in a wet place and not isolated or guarded.
- c. If in a hazardous location.
- d. If the motor operates with any terminal at more than 150 volts to ground.

If the frame of the motor is not grounded, it shall be permanently and effectively insulated from the ground.

**Portable Motors.** The frames of portable motors which operate at more than 150 volts to ground shall be guarded or grounded.

It is recommended that the frames of motors which operate at less than 150 volts to ground be grounded if this can be readily accomplished.

MOTOR WIRING AND  
OVERCURRENT PROTECTION

Maximum Allowable Rating of Branch Circuit Fuses

Col. No. 1	Minimum size conductor in raceways For conductors in air or for other insulations (see tables 1 and 2)			For Running Protection of Motors		7	8	9	10				
	AWG and MCM			Maximum rating of N.E.C. fuses	Maximum setting of time-limit protective device					15	15	15	15
	Type R	Type RP	Type RH										
1**	14	14	14	2*	1.25*	15	15	15	15				
2**	14	14	14	3*	2.50*	15	15	15	15				
3**	14	14	14	4*	3.75*	15	15	15	15				
4**	14	14	14	6*	5.0 *	15	15	15	15				
5**	14	14	14	8*	6.25*	15	15	15	15				
6**	14	14	14	8*	7.50*	20	15	15	15				
7	14	14	14	10*	8.75*	25	20	15	15				
8	14	14	14	10*	10.0 *	25	20	20	15				

**With Code Letters**  
Single-phase and squirrel cage and synchronous. Full voltage, resistor and reactor starting, Code letters F to R inc.  
**Without Code Letters**  
Same as above.

**With Code Letters**  
Single-phase and squirrel cage and synchronous. Full voltage, resistor or reactor starting, Code letters B to E inc. Auto-transformer starting, Code letters F to R inc.  
**Without Code Letters**  
Squirrel cage and synchronous, auto-transformer starting, High reactance squirrel cage. Both not more than 30 amperes

**With Code Letters**  
Squirrel cage and synchronous Auto-transformer starting, Code letters B to E inc.  
**Without Code Letters**  
Squirrel cage and synchronous, auto-transformer starting, High reactance squirrel cage.

**With Code Letters**  
All motors. Code letter A.  
**Without Code Letters**  
DC and wound-rotor motors.

# MOTORS

## MOTOR WIRING AND OVERCURRENT PROTECTION (Continued)

9	14	14	14	14	12*	11.25*	30	25	20	15
10	14	14	14	15*	12.50*	12.50*	30	25	20	15
11	14	14	14	15*	13.75*	13.75*	35	30	25	20
12	14	14	14	15	15.00	15.00	40	30	25	20
13	12	14	14	20	16.25	16.25	40	35	30	20
14	12	14	14	20	17.50	17.50	45	35	30	25
15	12	12	14	20	18.75	18.75	45	40	30	25
16	12	12	14	20	20.00	20.00	50	40	35	25
17	10	12	14	25	21.25	21.25	60	45	35	30
18	10	12	12	25	22.50	22.50	60	45	40	30
19	10	10	12	25	23.75	23.75	60	40	30	30
20	10	10	12	25	25.0	25.0	60	50	40	30
22	8	10	10	30	27.50	27.50	70	60	45	35
24	8	10	10	30	30.00	30.00	80	60	50	40
26	8	8	10	35	32.50	32.50	80	70	60	40
28	8	8	10	35	35.00	35.00	90	70	60	45
30	6	8	8	40	37.50	37.50	90	70	60	45
32	6	8	8	40	40.00	40.00	100	80	70	60
34	6	6	8	45	42.50	42.50	110	90	70	60
36	6	6	8	45	45.00	45.00	110	90	80	60
38	5	6	8	50	47.50	47.50	125	100	80	60
40	5	6	6	50	50.00	50.00	125	100	80	60
42	5	5	6	50	52.50	52.50	125	90	80	70
44	4	5	6	60	55.0	55.0	125	110	90	70
46	4	5	6	60	57.50	57.50	160	125	100	70
48	4	5	6	60	60.0	60.0	150	100	100	80
50	3	5	6	60	62.50	62.50	150	125	100	80
52	3	4	6	70	65.0	65.0	175	110	110	80
54	3	4	5	70	67.50	67.50	175	150	110	90
56	3	4	5	70	70.00	70.00	175	160	120	90
58	2	3	5	70	72.50	72.50	175	160	120	90
60	2	3	5	80	75.00	75.00	200	150	120	90
62	2	3	4	80	77.50	77.50	200	175	125	100
64	2	3	4	80	80.00	80.00	200	175	160	100
66	1	3	4	80	82.50	82.50	200	175	160	100
68	1	2	4	90	85.00	85.00	225	175	160	110
70	1	2	3	90	87.50	87.50	225	175	160	110

Col. No. 1	Minimum size conductor in raceways For conductors in air or for other insulations (see tables 1 and 2) AWG and MCM			For Running Protection of Motors		Maximum Allowable Rating of Branch Circuit Fuses			
	Type R	Type RP	Type RH	Maximum rating of N.E.C. fuseq	Maximum setting of time-limit protective device	With Code Letters Single-phase and squirrel cage and synchronous. Full voltage, resistor and reactor starting, Code letters F to R inc. Without Code Letters Same as above.	With Code Letters Single-phase and squirrel cage and synchronous. Full voltage, resistor or reactor starting, Code letters B to E inc. Auto-transformer starting, Code letters F to R inc. Without Code Letters Squirrel cage and synchronous, auto-transformer starting, High reactance squirrel cage. Both not more than 30 amperes	With Code Letters Squirrel cage and synchronous Auto-transformer starting, Code letters B to E inc. Without Code Letters Squirrel cage and synchronous, auto-transformer starting, High reactance squirrel cage.	With Code Letters All motors. Code letter A. Without Code Letters DC and wound-rotor motors.
	2	3	4	Amperes 5	Amperes 6	7	8	9	10
72	1	2	3	90	90.00	225	200	150	110
74	0	2	3	90	92.50	225	200	150	125
76	0	2	3	100	95.00	250	200	175	125
78	0	1	3	100	97.50	250	200	175	125
80	0	1	2	100	100.00	250	200	175	125
82	0	1	2	110	102.50	250	225	175	125
84	0	1	2	110	105.00	250	225	175	150
86	00	1	2	110	107.50	300	225	175	150
88	00	1	2	110	110.00	300	225	200	150
90	00	0	2	110	112.50	300	225	200	150
92	00	0	2	125	115.00	300	250	200	150
94	00	0	1	125	117.50	300	250	200	150
96	00	0	1	125	120.00	300	250	200	150
98	000	0	1	125	122.50	300	250	200	150
100	000	0	1	125	125.00	300	250	200	150
105	000	00	1	150	131.5	350	300	225	175

MOTOR WIRING AND  
OVERCURRENT PROTECTION  
(Continued)

MOTORS

# MOTORS

## MOTOR WIRING AND OVERCURRENT PROTECTION

(Continued)

110	0000	00	0	150	137.5	350	300	225	175
115	0000	00	0	150	144.0	350	300	250	175
120	0000	000	0	150	150.0	400	300	250	200
125	0000	000	00	175	156.5	400	350	250	200
130	250	000	00	175	162.5	400	350	300	200
135	250	0000	00	175	169.0	450	350	300	225
140	250	0000	000	175	175.0	450	350	300	225
145	300	0000	000	200	181.5	450	400	300	225
150	300	0000	000	200	187.5	450	400	300	225
155	300	0000	000	200	194.0	500	400	350	250
160	350	250	000	200	200.0	500	400	350	250
165	350	250	0000	225	206.	500	450	350	250
170	350	250	0000	225	213.	500	450	350	300
175	400	300	0000	225	219.	600	450	350	300
180	400	300	0000	225	225.	600	450	400	300
185	400	300	0000	250	231.	600	500	400	300
190	500	300	250	250	238.	600	500	400	300
195	500	350	250	250	244.	600	500	400	300
200	500	350	250	250	250.	600	500	400	300
210	500	400	300	250	263.	600	600	450	350
220	600	400	300	300	275.	600	600	450	350
230	600	500	300	300	288.	600	600	500	350
240	700	500	350	300	300.	600	600	500	400
250	700	500	350	300	313.	600	600	500	400
260	750	600	400	350	325.	600	600	600	400
270	800	600	400	350	338.	600	600	600	450
280	900	600	500	350	350.	600	600	600	450
290	900	700	500	350	363.	600	600	600	450
300	1000	700	500	400	375.	600	600	600	450
320	1250	750	600	400	400.	600	600	600	500
340	1500	900	600	450	425.	600	600	600	600
360	1750	1000	700	450	450.	600	600	600	600
380	.....	1250	750	500	475.	600	600	600	600
400	.....	1500	900	500	500.	600	600	600	600
420	.....	1500	1000	600	525.	600	600	600	600
440	.....	1750	1250	600	550.	600	600	600	600
460	.....	.....	1250	600	575.	600	600	600	600
480	.....	.....	1500	600	600.	600	600	600	600
500	.....	.....	1500	.....	625.	600	600	600	600

## MOTORS

### MOTOR WIRING AND OVERCURRENT PROTECTION

Code letters referred to in the preceding tables are those marked on motor name-plates to show the motor input with the rotor locked. Following are the values in kilovolt-amperes per horsepower corresponding to the letters. This is a standard of the National Electrical Manufacturers Association.

Code Letter	Kilovolt-Amperes per Horsepower, with Locked Rotor
A .....	0— 3.14
B .....	3.15— 3.54
C .....	3.55— 3.99
D .....	4.0 — 4.49
E .....	4.5 -- 4.99
F .....	5.0 — 5.59
G .....	5.6 — 6.29
H .....	6.3 — 7.09
J .....	7.1 — 7.99
K .....	8.0 — 8.99
L .....	9.0 — 9.99
M .....	10.0 —11.19
N .....	11.2 —12.49
P .....	12.5 —13.99
R .....	14.0 —and up

High reactance squirrel cage motors referred to in preceding tables are those designed to limit the starting current by means of deep-slot secondaries or double-wound secondaries. They generally are started on full voltage

#### Disconnecting Means

The disconnecting means (Fig. 13-1) shall be a motor circuit switch, rated in horsepower, or a circuit-breaker, except as follows:

a.  $\frac{1}{8}$  Horsepower or Less. For stationary motors of  $\frac{1}{8}$  horsepower or less the branch-circuit overcurrent device may serve as the disconnecting means.

b. Two Horsepower or Less. For stationary motors rated at 2 horsepower or less and 300 volts or less, the disconnecting means may be a general-use switch having an ampere rating at least twice the full-load current rating of the motor.

c. Exceeding 50 Horsepower. For stationary motors rated at more than 50 horsepower, the disconnecting means may be a motor-circuit switch also rated in amperes, a general-use switch, or an isolating switch.

## MOTORS

It is recommended that isolating switches for motors exceeding 50 horsepower, not capable of interrupting stalled-rotor currents, be plainly marked "Do not open under load."

d. **Portable Motors.** For portable motors an attachment plug and receptacle may serve as the disconnecting means.

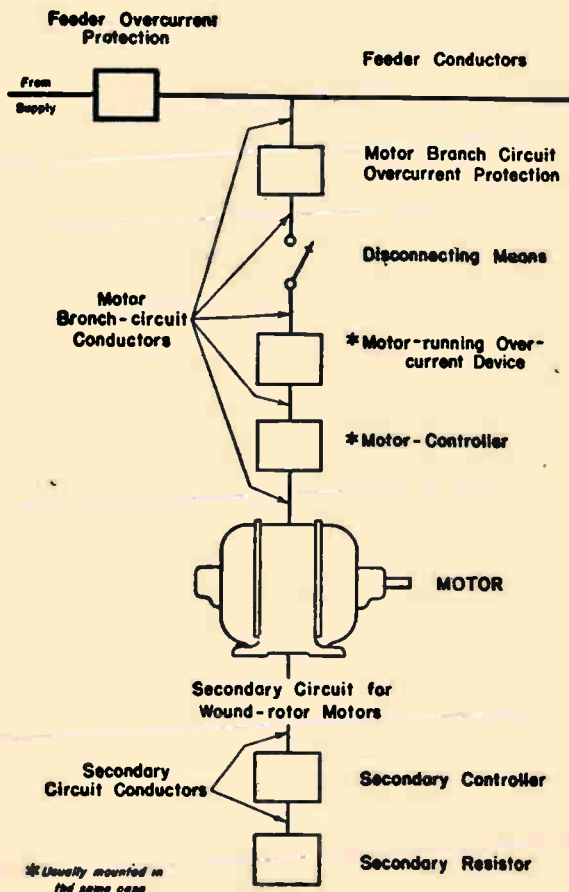


Fig. 13-1. Motor feeder and branch circuits, showing the relative positions of overcurrent protection, disconnecting means, and controller units. (From National Electrical Code).

## MOTORS

**Carrying Capacity.** The disconnecting means shall have a carrying capacity of at least 115 per cent of the name-plate current rating of the motor.

**Grounded Conductors.** One pole of the disconnecting means may be placed in a permanently grounded conductor if the disconnecting means is so designed that the pole in the grounded conductor cannot be opened without simultaneously disconnecting all conductors of the circuit.

**To Be Indicating.** The disconnecting means shall plainly indicate whether it is in the open or closed position.

**To Disconnect Both Motor and Controller.** The disconnecting means shall disconnect both the motor and the controller from all ungrounded supply conductors. The disconnecting means may be in the same enclosure with the controller.

**Switch or Circuit-Breaker as Both Controller and Disconnecting Means.** A switch or circuit-breaker of approved type may serve as both controller and disconnecting means if it opens all ungrounded conductors to the motor, is protected by an overcurrent device (which may be a set of fuses) which opens all ungrounded conductors to the switch or circuit-breaker, and is of one of the following types:

a. An air-break switch, operable directly by applying the hand to a lever or handle.

b. A circuit-breaker operable directly by applying the hand to a lever or handle.

c. An oil switch used on a circuit whose rating does not exceed 600 volts or 100 amperes, or on a circuit exceeding this capacity if under expert supervision and by special permission.

The oil switch or circuit-breaker specified above may be both power and manually operable. If power operable, provision should be made to lock it in the open position.

The overcurrent device protecting the controller may be part of the controller assembly or may be separate.

A compensator type of controller is not included above and will require a separate disconnecting means.

**Service Switch as Disconnecting Means.** If an installation consists of a single motor, the service switch may serve as the disconnecting means, provided it conforms to the requirements of these rules, and is within sight of the controller.

**In Sight of Controller.** The disconnecting means shall be located within sight of the controller or be arranged to be locked in the open position.

**Motors Served by a Single Disconnecting Means.** Each motor shall be provided with individual disconnecting means, except that for motors of 600 volts or less a single disconnecting means may serve a group of motors under any one of the following conditions. The disconnecting means serving a group of motors



## MOTORS

shall have a rating not less than is required by the first paragraphs of this section for a single motor whose rating equals the sum of the horsepowers or currents of all the motors of the group.

a. If a number of motors drive several parts of a single machine or piece of apparatus such as metal and woodworking machines, cranes, and hoists.

b. If a group of motors is under the protection of one set of overcurrent devices as permitted by applicable rules.

c. If a group of motors is in a single room within sight of the disconnecting means.

### MOTOR HORSEPOWER TEST

The horsepower of a motor may be measured by means of a Prony brake for speeds up to about 2,000 rpm and powers to about 10 hp., with an error of 1 to 5 per cent.

The Prony brake, as shown by Fig. 13-2, consists of a pulley or drum driven by the motor, of wooden blocks clamped with variable pressure by screws, and of an arm extending from the blocks to a scale, preferably of the platform type.

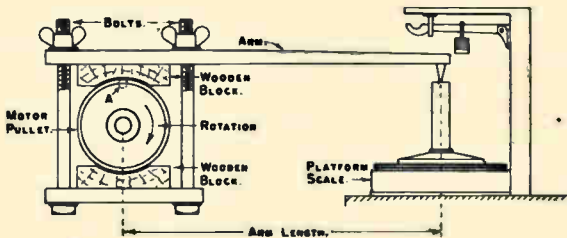


Fig. 13-2

The first step is to support the upper block, without the pulley in place, by a small rod at A while the outer end of the arm together with its supports rests on the scale. The weight now indicated by the scale is to be noted, since it later will be subtracted from the number of pounds indicated during tests. Note should be made also of the length of the arm, in feet, from the center of the pulley to the point of contact with the scale.

With the motor running, and driving the pulley, the brake blocks are gradually tightened to impose a load on the motor. Simultaneous measurements are made of the number of pounds indicated by the scale and of the pulley speed in rpm, by using a revolution counter and stop watch or else some kind of tachom-

## MOTORS

### REQUIREMENTS FOR SMALL A-C MOTORS

Single-Phase and Universal  
(Federal Specifications)

Characteristics—Types	Horsepower					
	1/8	1/6	1/4	1/3	1/2	3/4
Current, locked rotor, amps.						
At 110 volts	20	20	23	31	45	61
At 220 volts	10	10	11½	15½	22½	30½
Torque, starting (% of full-load)						
Split-phase motors						
60-cycle, 1725 rpm.	150	150	90			
60-cycle, 1140 rpm.	125	125	75			
25-cycle, 1425 rpm.	125	125	75			
Capacitor motors, high torque						
60-cycle, 1725 rpm.	300	300	300	300	300	275
60-cycle, 1140 rpm.	300	300	300	300	300	
25-cycle, 1425 rpm.	300	300	300	300	300	300
Repulsion-start Induction						
60-cycle, 1725 rpm.	350	350	350	350	350	350
60-cycle, 1140 rpm.	300	300	300	300	300	
25-cycle, 1425 rpm.	300	300	300	300	300	300
Power Factor, per cent						
60-cycle, 900 rpm.	36	38	40	41	43	44
60-cycle, 1200 rpm.	43	46	49	50	52	53
60-cycle, 1800 rpm.	52	56	60	61	63	65
60-cycle, 3600 rpm.	57	62	66	67	69	72
25-cycle, 1500 rpm.	52	56	60	61	63	65
Efficiency, per cent						
60-cycle, 900 rpm.	38	42	45	46	47	49
60-cycle, 1200 rpm.	45	49	53	54	55	57
60-cycle, 1800 rpm.	53	58	62	63	65	67
60-cycle, 3600 rpm.	45	49	53	54	55	57
25-cycle, 1500 rpm.	45	49	53	54	55	57
Speed, rpm.				Synchronous	Full-load	(minimum)
60-cycle, 8-pole			900		860	
60-cycle, 6-pole			1200		1135	
60-cycle, 4-pole			1800		1720	
60-cycle, 2 pole			3600		3440	
25-cycle, 2-pole			1500		1420	

## MOTORS

eter. The net weight is determined by subtracting from the indicated weight the weight previously measured with the blocks supported by a rod.

Brake horsepower is equal to the product of the arm length in feet, the revolutions per minute, and the net weight in pounds, divided by 5250.

$$\text{BHP} = \frac{\text{arm, feet} \times \text{rpm.} \times \text{net lbs.}}{5250}$$

The blocks usually are about as wide as  $1\frac{1}{2}$  times the motor shaft diameter. For air-cooled blocks the pulley diameter in inches may be about 24 times the horsepower of the motor, divided by the block width in inches. With water cooling for blocks and pulley the horsepower need be multiplied by only 5 to 10 times instead of 24.

Torque in foot-pounds is equal to the length of the arm in feet multiplied by the net weight in pounds. By applying enough clamp pressure to bring the motor to its normal running speed (synchronous minus slip) the full-load torque may be determined. Clamping to prevent pulley rotation allows determining locked rotor torque.

### Locked Rotor Torque Standards

The locked rotor torque of normal-torque types of squirrel cage induction motors (Classes A and B) should be no less than the following percentages of the running torque corresponding to rated load, when the rated voltage is applied. This is a standard of the National Electrical Manufacturers Association.

2-pole motor	150%	10-pole motor	120%
4-pole motor	150%	12-pole motor	115%
6-pole motor	135%	14-pole motor	110%
8-pole motor	125%	16-pole motor	105%

For low starting torque types of squirrel cage induction motors (Classes E and F) the locked rotor torque should be not less than 50% of the running torque corresponding to rated load, with rated voltage applied.

### Checking the Speed of Induction Motors

Quite frequently the maintenance electrician may need to determine the actual operating speed of an A.C. induction motor, when no tachometer or speed indicator is available. In such cases one of the following simple methods may be quite convenient.

If a millivoltmeter is available, connect its terminals to the ends of the shaft of the squirrel cage motor, as shown at A in Fig. 13-3. If the motor is of the slip ring type, connect the meter leads to the slip rings as shown at B.

## MOTORS

The meter will then indicate the low frequency induced currents in the rotor and shaft, due to the slip or difference in speed between the revolving magnetic

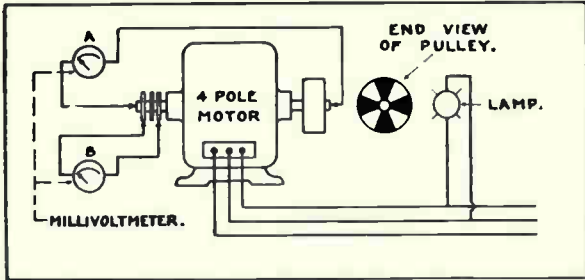


Fig. 13-3

field of the stator and the speed of the rotor. Each complete cycle or forward and backward swing of the meter needle will indicate a slip of one pair of poles.

Counting the number of swings per minute and dividing this figure by the number of pairs of poles in the machine will indicate the slip R.P.M. The R.P.M. of the stator field may be determined by the following formula:  $R.P.M. = 120 \times \text{frequency} \div \text{number of poles}$ . Then subtracting the slip R.P.M. from the field R.P.M. will give the actual motor speed.

Another method of determining the speed of A.C. induction motors is by means of a stroboscopic principle. Black and white sectors can be painted on the end of the motor pulley, or on a card attached to the pulley. See Fig. 13-3. Be sure to have as many black sectors as there are poles in the machine. Then with the motor running and the pulley shielded from other sources of bright light, illuminate it with a 10-watt lamp, or better still a 2-watt neon bulb, connected to the same A.C. line as the motor.

On a synchronous motor the black sectors would move forward one pole for each alternation, and as they are illuminated by the lamp once during each alternation, they would appear to stand still. On an induction motor which operates at less than synchronous speed due to the slip, these sectors will appear to move backward or opposite to motor rotation. Count the number of apparent backward revolutions per minute and again subtract from the rotating magnetic field R.P.M. and the result will be the actual motor speed.

## MOTORS

### ADAPTING INDUCTION MOTORS TO NEW OPERATING CONDITIONS

The rate at which many industrial plants are expanding their facilities for increased production is creating new responsibilities and opportunities for maintenance electricians.

Due to the difficulty involved in obtaining new equipment fast enough to meet expansion requirements, idle electrical machines of the older types are being rehabilitated and converted to use under changed conditions. Motors out of service for years are being adapted to new operating conditions by reconnecting or rewinding.

Every maintenance electrician should be alert to opportunities to convert such idle equipment to useful service.

The replacement of 25 cycle energy by a 60 cycle supply presents the problem of adapting the existing 25 cycle motors to 60 cycle operation. Three methods may be employed to accomplish the above: First, a change in applied voltage; second, a change in the winding connections; third, a complete rewinding job. The method ultimately employed in any given case will depend upon the conditions.

By the first method, a 110 volt 25 cycle motor may be operated from a 220 volt 60 cycle circuit, and a 220 volt 25 cycle motor can be connected to a 440 volt 60 cycle circuit. In both cases, the motor's speed and h. p. rating will be approximately doubled. The peripheral speed of the rotor must be given consideration in such a change, for, should the rim speed exceed 7,000 feet per minute, there is a possibility of the rotor being unable to withstand the increased centrifugal stresses. The speed of the machine driven by such a motor may be maintained at its normal value by reducing the size of the motor pulley to approximately one-half its original diameter, or by increasing the size of the driven pulley to twice its original diameter.

The second change—that of reconnection—is designed to enable the motor to operate at name-plate rated voltage on 60 cycles. This method can be employed on motors that are designed to operate on two voltages, such as 110-220 or 220-440. Thus a 110-220 volt 25 cycle motor may be changed to 60 cycle operation at 220 volts by connecting it the same as for operation on 110 volts, 25 cycles. If the leads are not brought out, the internal sections of the windings may be paralleled. For example, a 4 pole, 220 volt, 25 cycle motor, having all poles connected in series, may be reconnected for a 220 volt 60 cycle circuit by

## MOTORS

having its poles connected two in series and the two groups in parallel; similarly, a 25 cycle single-circuit-star motor can be converted to 60 cycle operation on the same voltage by changing the connection to two-circuit-star. As in the previous examples, **these changes will be accompanied by doubled speed and horsepower.**

The last mentioned change—that concerned with rewinding — is generally necessary when 25 cycle motors have to be changed to 60 cycle operation without any considerable change in speed. This means that the motor **must be wound for twice as many poles when operating on 60 cycles.** The general rules for rewinding are:

Rewind the new coils for one-half the original coil span, using the next larger size of wire, and eighty-four per cent of the original turns. The winding connection will remain unchanged; that is, if the original winding was series-star, the new winding will be connected in a similar manner. With this arrangement, the horsepower and speed will increase about twenty per cent.

Sometimes a combination of speed and frequency change may be accomplished without rewinding, but such re-connections are rare. In general, the relationship to keep in mind is that the number of turns in series in any given phase or section of the winding must be made to vary in inverse proportion to the proposed change in frequency, and in direct proportion to the change in voltage.

With induction type motors, a change in speed invariably involves a change in the number of poles set up by the winding and, since this implies a variation in the coil span, rewinding is usually required. For example, to change the speed of a 1800 RPM motor to 900 RPM on the same voltage and frequency, rewind the stator employing one-half the original coil span and double the number of turns per coil. Wire size must be halved and original connections preserved. If the motor was originally 4 pole series star, the new winding will be 8 pole series star. Such a change will maintain the original torque but will decrease the horsepower in proportion to the speed. Changes from low to high speed demand consideration of the depth of iron behind the stator teeth, as a decrease in the number of poles increases the flux in this area.

When windings are changed for operation on a different voltage, frequency, or speed, it is important that the flux density in both the teeth and the back

## MOTORS

iron will be unchanged. Low densities decrease the torque and power; higher densities result in overheating.

When such changes are made the following should be kept in mind:

1. Increase in the number of poles reduces the flux per pole in inverse proportion.
2. Increase in the number of poles reduces the speed of the rotating magnetic field in inverse proportion. Thus when the number of poles in a winding is doubled, the flux per pole is halved; however, the total flux in the air gap is unchanged as there are twice as many poles with one-half flux per pole. Consequently, the torque developed is unchanged. But the speed of the rotating magnetic field is halved and the counter voltage is similarly reduced. The horsepower developed will reflect a proportionate decrease.
3. Increase in the frequency raises the speed of the rotating magnetic field and the counter-E.M.F. in proportion. If voltage applied to the winding is raised in proportion to the speed, the flux will remain constant, the torque will remain constant, but the horsepower will vary as the R.P.M.
4. When the coil span of a winding with a given number of poles is reduced, the C.E.M.F. generated by the winding is diminished in proportion. Therefore the voltage applied to the winding must be decreased.

Taking all changes into consideration a 25 cycle, 2 pole motor will, when changed to 4 pole, 60 cycle with the same chord factor, have the same air gap flux,  $\frac{1}{2}$  the back iron flux,  $1800/1500$  of the original speed and  $1800/1500$  of the original C.E.M.F. Since the C.E.M.F. should approximately equal the applied voltage the number of turns per phase will have to be reduced to  $1500/1800$  of the original value or 84%. Thus the machine should be rewound with 84% of original turns and one size larger wire.

In some cases the problem is one involving a change in the number of phases. As such changes may affect both speed and h.p. output, it is imperative that the ultimate results of the conversion be understood before reconnecting or rewinding is attempted. A modification not uncommon is the changing of a two-phase motor to three-phase operation. The possibilities associated with such a change will now be considered.

The simplest change with regard to phase variation is the reconnecting of a two-phase series-connected motor to three-phase series-star. When so changed, however, the three-phase winding contains 25% more turns per phase than is required if the

## MOTORS

same value of line voltage is to be employed. In other words, a two-phase series-connected 220-volt motor will, when connected three-phase series-star, require a voltage of 275 volts between lines if the same voltage per coil is to be maintained. Since this is usually impracticable, normal voltage per coil may be obtained by cutting out one-fifth of the coils; these coils should be spaced around the stator as symmetrically as possible in order to avoid unbalanced phase voltages. Furthermore, since the normal full load current per line wire for a three-phase motor is 12.5% greater than that drawn by the two-phase motor for the same line voltage, it is evident that the three-phase h.p. will be less than rated two-phase h.p. by this amount. However, as the average motor will withstand a 15% overload without injury, equal h.p. on the three-phase connection may be obtained.

Due to the fact that the voltage impressed across the insulation between phases may equal the line voltage, motor manufacturers invariably place heavier insulation on the coils at the ends of the pole phase groups; therefore when a change from two-phase to three-phase is made, the insulation on the phase coils should be changed if the possibility of insulation breakdown is to be minimized. This change, which implies the insertion of extra insulation between the pole phase groups, should always be performed where conditions permit; however, where windings have been heavily doped, this may be impractical. On low voltage machines, it may be possible to effect a phase change that will perform satisfactorily without the extra insulation mentioned, although the strain on certain sections of the motor winding is increased, and the possibility of failure enhanced.

A combined voltage and phase conversion frequently made is the change from 440 volts two-phase to 550 volts three-phase. Under these circumstances, all stator coils are used effectively in both connections, the motor performing equally well under either condition. One precaution that must be strictly observed when making phase changes is the avoidance of parallel circuits, particularly where such circuits contain dead coils; for the prevention of circulating currents can be effected only if the voltages induced in the parallel sections are not only equal in value, but also in phase with each other. Thus it is possible to have two parallel circuits in a phase, each containing an equal number of coils, that will produce excessive heating due to the differences in phase of the induced voltages in the two apparently equivalent sections. It follows that a careful consideration of all of the factors affecting the ultimate distribution of



## MOTORS

current should be made before a change in the connection is attempted, as only by such a procedure can unsatisfactory performance be avoided.

When a change in the number of phases is contemplated, consideration of the relation between the number of slots per pole in the original and the proposed winding is essential, for a symmetrical winding is not possible unless the number of slots per pole is divisible by the number of phases. For example, if a 48 slot, 6 pole stator is to be converted from 2 phase to 3 phase operation, it will not be possible to get an equal number of coils per phase in each pole, as the number of slots per pole (8) is not divisible by the proposed number of phases (3). As there should be an equal number of coils in each phase, unequal coil grouping—an arrangement employed to insure the above requirement—must be used. The manner in which the coils may be arranged to achieve a balanced 3 phase winding in a 6 pole, 48 slot stator is indicated in the following chart.

	Phase A	Phase B	Phase C
1st pole	3	3	2
2nd pole	2	3	3
3rd pole	3	2	3
4th pole	3	3	2
5th pole	2	3	3
6th pole	3	2	3
	—	—	—
Total per phase	16	16	16

This method of obtaining a balanced winding is frequently used where a change in the number of phases is desired.

While this article does not cover all possible changes, it does show how a number of the frequently desirable conversions may be effected. By carefully following the instructions given, many graduates should be able to effect considerable savings and help to avoid production delays by converting idle motors to active use.

### TERMINAL MARKINGS

The purpose of marking the terminals of electric power apparatus with standardized letters, numbers and other symbols is to aid in making correct connections between parts of the power system.

Standardized markings sponsored by the National Electrical Manufacturers Association have been approved by the American Standards Association. These standards apply to motors, generators, synchronous converters and constant potential transformers. The markings are used only for terminals to which connection must be made from outside circuits or from

## MOTORS

auxiliary devices which must be disconnected for shipment. They are not intended to be used for internal machine connections.

There is the possibility of finding terminals unmarked, or marked without any system, or marked with some system other than standard. There is the further possibility that internal connections may have been changed or that errors may have escaped detection. It is advisable, therefore, before making connections, to make the usual check tests for polarity, equality of voltage, phase relation and phase rotation unless it is known that the markings are correct.

Markings consist of a capital letter which indicates the character or function of the winding which is brought to the terminal or indicates the external connection which should be made. For example, the letter S indicates a series field connection.

With the capital letters are used subscript numbers; 0, 1, 2, 3, etc. Following are the meanings of the letters.

### Rotating Apparatus and Control (Except railway motors)

A	Armature; brush on commutator.
B	Brake
BF	Booster field
BR	Shunt brake resistor
C	Commutating field
DR	Dynamic braking resistor
F	Shunt field
J	Capacitor
L	Line
M	Brush on collector ring (except d-c field)
R	Resistance, armature and miscellaneous
S	Series field
T	Stator (alternating-current only)
V	Resistance, shunt field adjusting
=	Equalizing lead
o	(subscript) Neutral connection

### Railway Motors

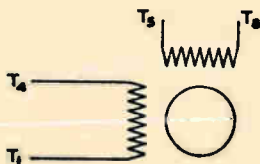
A	Armature (connected to brush holder)
AA	Armature (connected to brush holder or to commuting pole)
C, CC	External leads when commutating field windings are not permanently connected to the armature
D, DD	Compensating field
F, FF	Main field.
M	Field control lead
MM	Additional field control lead.

Uses of subscript letters in identifying opposite ends of a winding, related parts, parts to be connected, etc., are evident in following diagrams of motors where terminal letters and numbers are shown.

## MOTORS

### SINGLE-PHASE A-C MOTORS Connections and Terminal Markings SPLIT-PHASE TYPES

#### REVERSIBLE MOTOR, AUTOMATIC CUTOUT

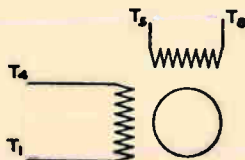


		L <sub>1</sub>	L <sub>2</sub>
One direction rotation	Start	T <sub>1</sub> T <sub>5</sub>	T <sub>4</sub> T <sub>6</sub>
	Run	T <sub>1</sub>	T <sub>4</sub>
Other direction rotation	Start	T <sub>1</sub> T <sub>6</sub>	T <sub>4</sub> T <sub>5</sub>
	Run	T <sub>1</sub>	T <sub>4</sub>

#### NON-REVERSIBLE MOTOR, AUTOMATIC CUTOUT



#### REVERSIBLE MOTOR, MANUAL CUTOUT



		L <sub>1</sub>	L <sub>2</sub>	Open
One direction rotation	Start	T <sub>1</sub> T <sub>5</sub>	T <sub>4</sub> T <sub>6</sub>	—
	Run	T <sub>1</sub>	T <sub>4</sub>	T <sub>5</sub> T <sub>6</sub>
Other direction rotation	Start	T <sub>1</sub> T <sub>6</sub>	T <sub>4</sub> T <sub>5</sub>	—
	Run	T <sub>1</sub>	T <sub>4</sub>	T <sub>5</sub> T <sub>6</sub>

Fig. 13-4. American Standards

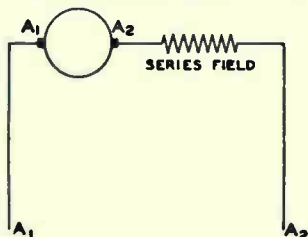
# MOTORS

## SINGLE-PHASE A-C MOTORS

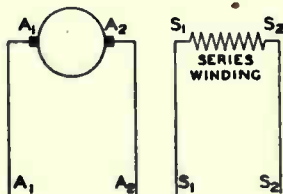
Connections and Terminal Markings

### SERIES TYPES

UNIVERSAL, NON-REVERSING,  
NOT COMPENSATED



UNIVERSAL, REVERSING,  
NOT COMPENSATED



	L <sub>1</sub>	L <sub>2</sub>	Tie Together
One direction rotation	A <sub>1</sub>	S <sub>2</sub>	A <sub>2</sub> S <sub>1</sub>
Other direction rotation	A <sub>1</sub>	S <sub>1</sub>	A <sub>2</sub> S <sub>2</sub>

INDUCTIVELY COMPENSATED,  
SEPARATE STATOR WINDINGS

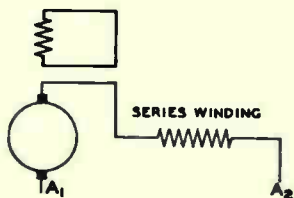


Fig. 13-5. American Standards

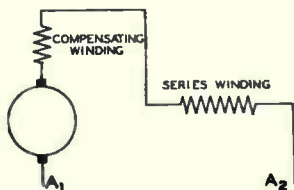
# MOTORS

## SINGLE-PHASE A-C MOTORS

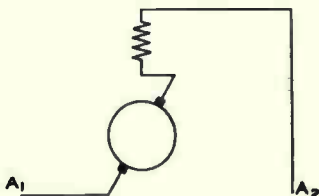
### Connections and Terminal Markings

#### SERIES TYPES

#### CONDUCTIVELY COMPENSATED, SEPARATE STATOR WINDINGS

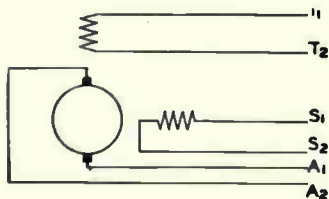


#### CONDUCTIVELY COMPENSATED, COMMON STATOR WINDINGS



#### CONDUCTIVELY COMPENSATED, REVERSIBLE,

#### SEPARATE STATOR WINDINGS

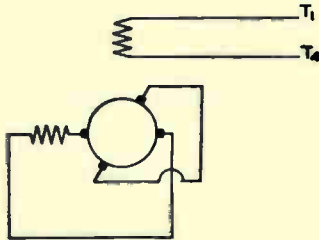


	L <sub>1</sub>	L <sub>2</sub>	Tie Together
One direction rotation	A <sub>1</sub>	S <sub>1</sub>	S <sub>2</sub> to T <sub>1</sub> & A <sub>2</sub> to T <sub>2</sub>
Other direction rotation	A <sub>1</sub>	S <sub>2</sub>	S <sub>1</sub> to T <sub>1</sub> & A <sub>2</sub> to T <sub>2</sub>

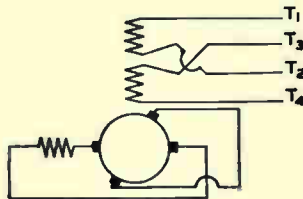
Fig. 13-6. American Standards

## MOTORS

### SINGLE-PHASE A-C MOTORS Connections and Terminal Markings REPULSION TYPES SINGLE VOLTAGE INDUCTIVELY COMPENSATED



### DOUBLE VOLTAGE INDUCTIVELY COMPENSATED



	L <sub>1</sub>	L <sub>2</sub>	Tie Together
Low Voltage	T <sub>1</sub> T <sub>3</sub>	T <sub>2</sub> T <sub>4</sub>	—
High Voltage	T <sub>1</sub>	T <sub>3</sub>	T <sub>2</sub> T <sub>4</sub>

### REPULSION OR REPULSION START SINGLE VOLTAGE, NOT COMPENSATED

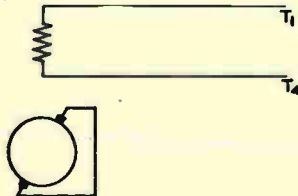


Fig. 13-7. American Standards

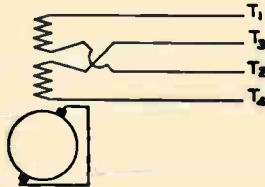
# MOTORS

## SINGLE-PHASE A-C MOTORS

Connections and Terminal Markings

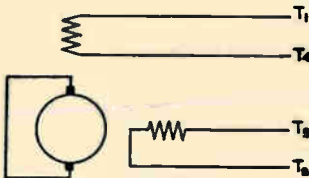
### REPULSION AND INDUCTION TYPES

#### REPULSION OR REPULSION-START DOUBLE VOLTAGE, NOT COMPENSATED



	L <sub>1</sub>	L <sub>2</sub>	Tie Together
Low Voltage	T <sub>1</sub> T <sub>3</sub>	T <sub>2</sub> T <sub>4</sub>	—
High Voltage	T <sub>1</sub>	T <sub>2</sub>	T <sub>3</sub> T <sub>4</sub>

#### REPULSION OR REPULSION-START SINGLE VOLTAGE, REVERSIBLE



	L <sub>1</sub>	L <sub>2</sub>	Tie Together
One direction rotation	T <sub>1</sub>	T <sub>2</sub>	T <sub>3</sub> T <sub>4</sub>
Other direction rotation	T <sub>1</sub>	T <sub>3</sub>	T <sub>2</sub> T <sub>4</sub>

#### INDUCTION TYPE, NON-REVERSIBLE, WITH STARTING BOX

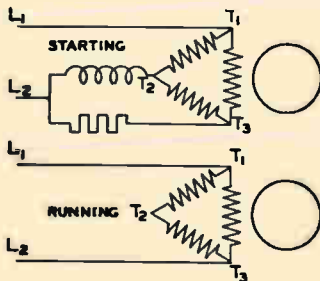


Fig. 13-8. American Standards

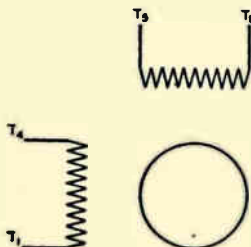
## MOTORS

### SINGLE-PHASE A-C MOTORS Connections and Terminal Markings

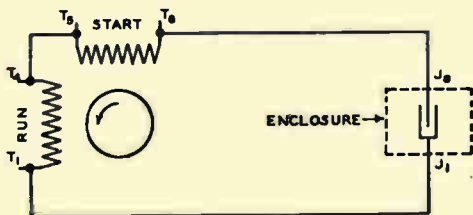
#### CAPACITOR TYPES

#### CAPACITOR START, CAPACITOR RUN MOTORS

#### CAPACITOR START, INDUCTION RUN MOTORS



#### LOW TORQUE, CAPACITOR ONLY.



#### HIGH TORQUE, CAPACITORS AND CONTACTOR

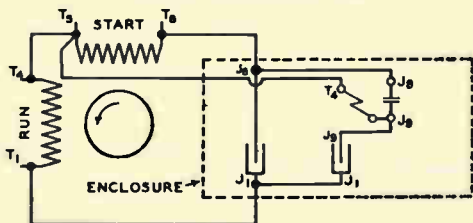
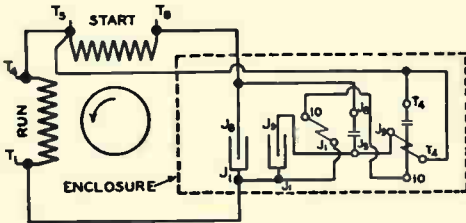


Fig. 13-9. American Standards

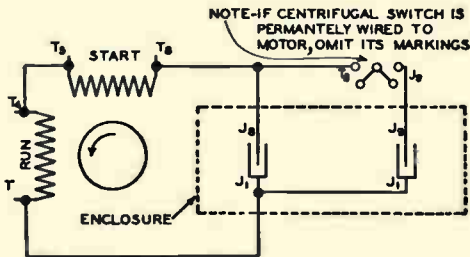


# MOTORS

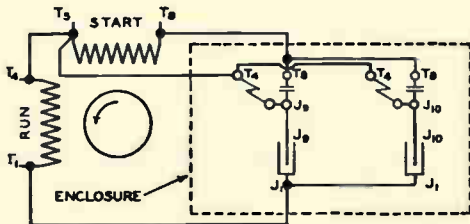
## SINGLE-PHASE A-C MOTORS Connections and Terminal Markings CAPACITOR TYPES



### HIGH TORQUE, CAPACITOR, RELAY AND CONTACTOR



### HIGH TORQUE, CAPACITOR & CENTRIFUGAL SWITCH



### HIGH TORQUE, CAPACITOR START, CAPACITOR RUN, TWO CONTACTORS

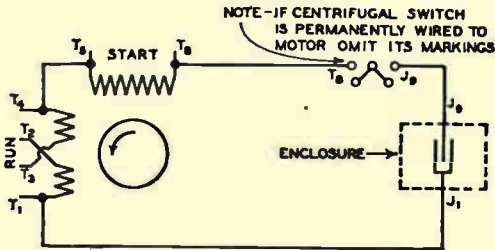
Fig. 13-10. American Standards

# MOTORS

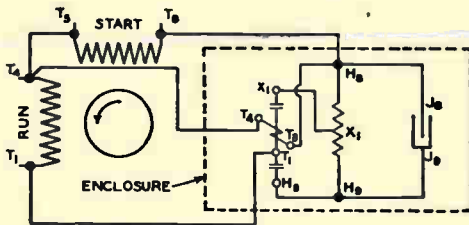
## SINGLE-PHASE A-C MOTORS

### Connections and Terminal Markings

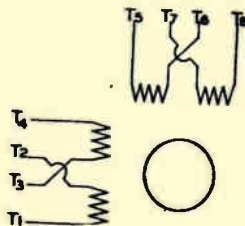
#### CAPACITOR TYPES



#### CAPACITOR START, INDUCTION RUN DUAL VOLTAGE



#### CAPACITOR START & RUN, WITH DOUBLE THROW CONTACTOR, TRANSFORMER AND CAPACITOR

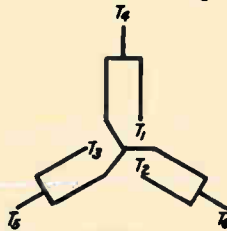


#### ANY DUAL VOLTAGE MOTOR, SERIES OR PARALLEL CONNECTIONS

Fig. 13-11. American Standards

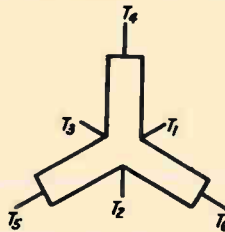
# MOTORS

## THREE-PHASE A-C MOTORS Connections and Terminal Markings VARIABLE TORQUE



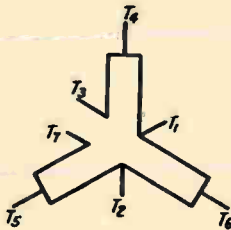
Speed	L <sub>1</sub>	L <sub>2</sub>	L <sub>3</sub>	Open	Tie Together
Low	T <sub>1</sub>	T <sub>2</sub>	T <sub>3</sub>	T <sub>4</sub> , T <sub>5</sub> , T <sub>6</sub>	—
High	T <sub>5</sub>	T <sub>4</sub>	T <sub>3</sub>	—	T <sub>1</sub> , T <sub>2</sub> , T <sub>3</sub>

## CONSTANT TORQUE



Speed	L <sub>1</sub>	L <sub>2</sub>	L <sub>3</sub>	Open	Tie Together
Low	T <sub>1</sub>	T <sub>2</sub>	T <sub>3</sub>	T <sub>4</sub> , T <sub>5</sub> , T <sub>6</sub>	—
High	T <sub>5</sub>	T <sub>4</sub>	T <sub>3</sub>	—	T <sub>1</sub> , T <sub>2</sub> , T <sub>3</sub>

## CONSTANT TORQUE

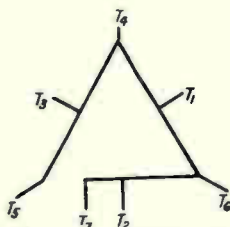


Speed	L <sub>1</sub>	L <sub>2</sub>	L <sub>3</sub>	Open	Tie Together
Low	T <sub>1</sub>	T <sub>2</sub>	T <sub>3</sub> , T <sub>7</sub>	T <sub>4</sub> , T <sub>5</sub> , T <sub>6</sub>	—
High	T <sub>5</sub>	T <sub>4</sub>	T <sub>3</sub>	—	T <sub>1</sub> , T <sub>2</sub> , T <sub>3</sub> , T <sub>7</sub>

Fig. 13-12. American Standards

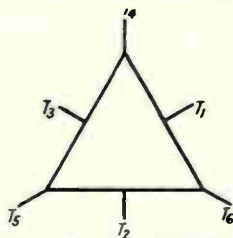
# MOTORS

## THREE-PHASE A-C MOTORS Connections and Terminal Markings CONSTANT HORSEPOWER



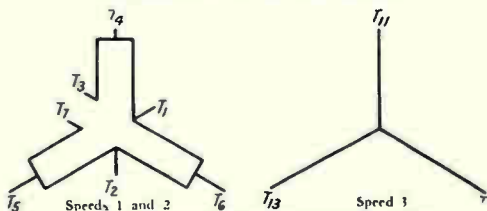
Speed	L <sub>1</sub>	L <sub>2</sub>	L <sub>3</sub>	Open	Tie Together
Low	T <sub>1</sub>	T <sub>2</sub>	T <sub>3</sub>	—	T <sub>4</sub> , T <sub>5</sub> , T <sub>6</sub> , T <sub>7</sub>
High	T <sub>6</sub>	T <sub>4</sub>	T <sub>5</sub> , T <sub>7</sub>	T <sub>1</sub> , T <sub>2</sub> , T <sub>3</sub>	—

## CONSTANT HORSEPOWER



Speed	L <sub>1</sub>	L <sub>2</sub>	L <sub>3</sub>	Open	Tie Together
Low	T <sub>1</sub>	T <sub>2</sub>	T <sub>3</sub>	—	T <sub>4</sub> , T <sub>5</sub> , T <sub>6</sub>
High	T <sub>6</sub>	T <sub>4</sub>	T <sub>5</sub>	T <sub>1</sub> , T <sub>2</sub> , T <sub>3</sub>	—

## 3-SPEED — 2 WINDINGS

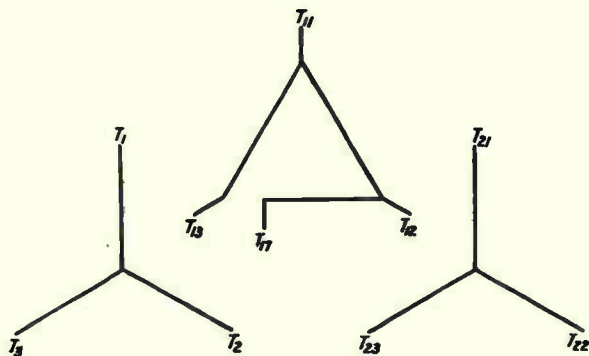


Speed	L <sub>1</sub>	L <sub>2</sub>	L <sub>3</sub>	Open	Tie Together
Low	T <sub>1</sub>	T <sub>2</sub>	T <sub>5</sub> , T <sub>7</sub>	T <sub>4</sub> , T <sub>5</sub> , T <sub>6</sub>	—
2nd	T <sub>6</sub>	T <sub>1</sub>	T <sub>5</sub>	—	T <sub>1</sub> , T <sub>2</sub> , T <sub>3</sub> , T <sub>7</sub>
High	T <sub>11</sub>	T <sub>12</sub>	T <sub>13</sub>	—	—

Fig. 13-13. American Standards

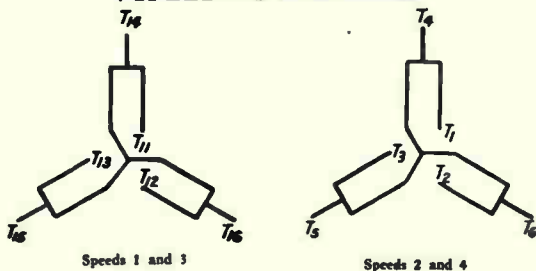
# MOTORS

## THREE-PHASE A-C MOTORS Connections and Terminal Markings 3-SPEED — 3 WINDINGS



Speed	L <sub>1</sub>	L <sub>2</sub>	L <sub>3</sub>	Open	Tie Together
Low	T <sub>1</sub>	T <sub>2</sub>	T <sub>3</sub>	T <sub>11</sub> , T <sub>12</sub> , T <sub>13</sub> , T <sub>17</sub> , T <sub>21</sub> , T <sub>22</sub> , T <sub>23</sub>	—
2nd	T <sub>11</sub>	T <sub>12</sub>	T <sub>13</sub> , T <sub>17</sub>	T <sub>1</sub> , T <sub>2</sub> , T <sub>3</sub> T <sub>21</sub> , T <sub>22</sub> , T <sub>23</sub>	—
High	T <sub>21</sub>	T <sub>22</sub>	T <sub>23</sub>	T <sub>1</sub> , T <sub>2</sub> , T <sub>3</sub> T <sub>11</sub> , T <sub>12</sub> , T <sub>13</sub> , T <sub>17</sub>	—

## 4-SPEED — 2 WINDINGS

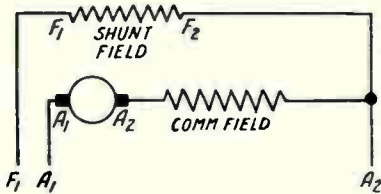


Speed	L <sub>1</sub>	L <sub>2</sub>	L <sub>3</sub>	Open	Tie Together
Low	T <sub>1</sub>	T <sub>2</sub>	T <sub>3</sub>	T <sub>4</sub> , T <sub>5</sub> , T <sub>6</sub>	—
2nd	T <sub>11</sub>	T <sub>12</sub>	T <sub>13</sub>	T <sub>14</sub> , T <sub>15</sub> , T <sub>16</sub>	—
3rd	T <sub>4</sub>	T <sub>5</sub>	T <sub>6</sub>	—	T <sub>1</sub> , T <sub>2</sub> , T <sub>3</sub>
High	T <sub>11</sub>	T <sub>12</sub>	T <sub>13</sub>	—	T <sub>11</sub> , T <sub>12</sub> , T <sub>13</sub>

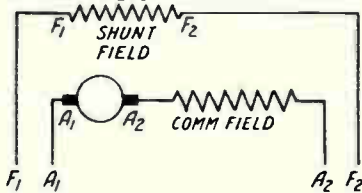
Fig. 13-14. American Standards

# MOTORS

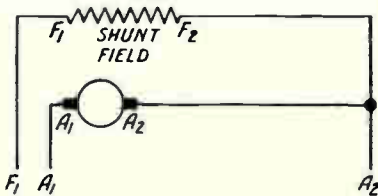
## DIRECT-CURRENT MOTORS Connections and Terminal Markings SHUNT-WOUND TYPES



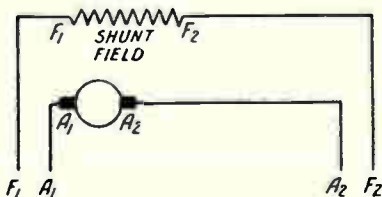
### NON-REVERSING COMMUTATING- POLE TYPE



### REVERSING COMMUTATING-POLE TYPE



### NON-REVERSING NON-COMMUTATING- POLE TYPE



### REVERSING NON-COMMUTATING- POLE TYPE

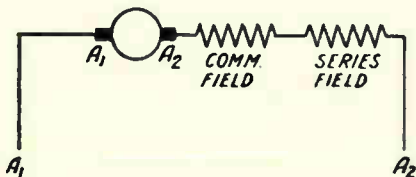
Fig. 13-15. American Standards

# MOTORS

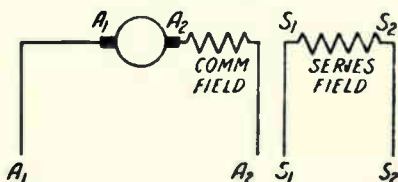
## DIRECT-CURRENT MOTORS

Connections and Terminal Markings

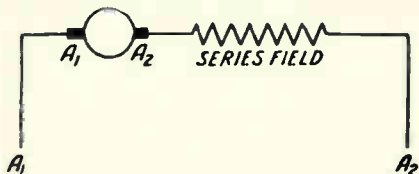
### SERIES-WOUND TYPES



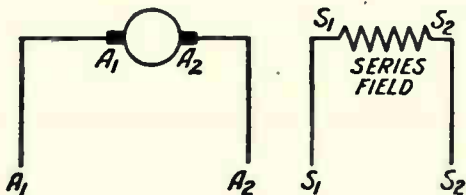
### REVERSING NON-COMMUTATING-POLE TYPE



### REVERSING COMMUTATING-POLE TYPE



### NON-REVERSING NON-COMMUTATING-POLE TYPE

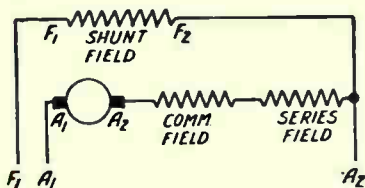


### NON-REVERSING COMMUTATING-POLE TYPE

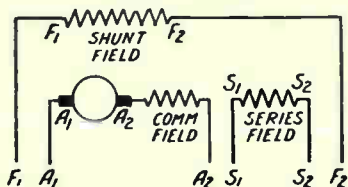
Fig. 13-16. American Standards

# MOTORS

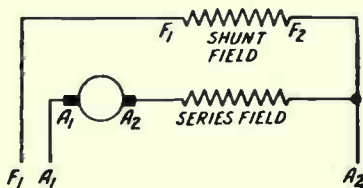
## DIRECT-CURRENT MOTORS Connections and Terminal Markings COMPOUND-WOUND TYPES



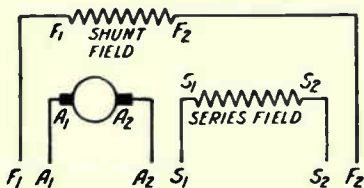
**NON-REVERSING COMMUTATING-  
POLE TYPE**



**REVERSING COMMUTATING-POLE TYPE**



**NON-REVERSING NON-COMMUTATING-  
POLE TYPE**



**REVERSING NON-COMMUTATING  
POLE TYPE**

**Fig. 13-7. American Standards**



## MOTORS

### MOTOR TROUBLES SINGLE PHASE A-C MOTORS

#### Motor Fails to Start

Fuses blown	Examine fuses, switches and connections between motor and service. Look for broken wires, loose terminal screws, etc.
Switch open	
Connections broken	
No line voltage	Test with voltmeter or test lamp.
Wiring too small	Low voltage or fluctuating voltage at motor
Overloaded line	
Motor too small	Reduce the load
Rotor rubs on stator	Put in new sleeves or bearings, center the stator.
Bearings tight or dry	Lubricate, adjust if needed.
Windings burned out	Indicated by local heating, smoke, burnt odor

#### Heating Excessive

Overload	Reduce the load
Grounds	Check with circuit tester
Short circuits	
Connections wrong	Check with wiring diagram.
Rotor rubs on stator	Check with feeler; repair or replace bearings.
Bearings worn	
Bearings too tight	Adjust; put in new sleeves.
Belt too tight	

#### Vibration Excessive

Rotor unbalanced	Remove and balance
Bearings worn	Repair or replace
Drive out of line	Align motor shaft with shaft of load; shafts parallel, belt at right angles to both.
Loose mounting	Tighten
Pulley unbalanced	Balance or replace
Belt heavy at some spots	Install new belt

## MOTORS

<b>Sparking When Starting</b>	
Commutator dirty or rough	Clean and sandpaper.
Brushes stuck, worn	Clean, renew if necessary.
Commutator bars high or low	Turn in lathe.
High mica	Undercut the mica
High starting load	Reduce load or use different type of starting control.
Open circuit in stator or rotor	Inspect, test and repair as necessary.
Grounds or shorts	
Poor connections	
Line voltage high or low	Consult power company.

<b>Sparking at Normal Speed</b>	
Dirty short-circuiting device	Clean with carbon tetrachloride
Governor sticks, or adjusted wrong	Clean and readjust

<b>Speed Too High</b>	
Dirty short-circuiting device	Clean with carbon tetrachloride
Governor sticks	Clean, adjust if needed

<b>Speed Too Low</b>	
Overloaded	Reduce the load.
Commutator dirty or rough	Clean and sandpaper.
Brushes worn, loose	Replace brushes.
Brushes set wrong	Adjust position.
Brushes sticking	Clean, adjust or replace.
Connections wrong	Check with diagram
Line voltage low or fluctuates	Reduce load on motor.
Wire gage too small	Rewire. Causes low voltage, especially when starting.

## MOTORS

### Hums, But Does Not Start

Brushes worn	Replace brushes.
Brushes stuck	Clean, adjust, or replace.
Brushes set wrong	Adjust position; see marks on frame or holders.
Overload	Lighten the load.
Opens in stator or rotor winding	Test and repair.
Bearings worn	Replace or adjust
Line voltage high or low	Consult power company.
Connections dirty or loose	Examine all wiring, clean tighten.

### Starts Only With Rotor in Certain Positions

Open winding in stator or rotor	Inspect, test, repair. May be due to burned, broken or loose internal connections.
---------------------------------	---

### Gains Speed Slowly (Poor Acceleration)

Commutator dirty or rough	Clean and sandpaper.
Brushes worn or stuck	Clean, adjust or replace
Brush position wrong	Readjust, check with marks on frame or holders.
Overloaded	Reduce the load.
Connections loose or dirty	Repair, clean, tighten.
Low starting voltage	Power line may be overloaded, or of too small wire gage.

### Brushes Wear Rapidly

Commutator rough	Smooth with fine sandpaper.
Bars high or low	Turn in a lathe.
High mica	Undercut the mica.
Overload (sparking)	Reduce the load

## MOTORS

Low voltage	Check line voltage, wire size, line loading.
Connections dirty or loose (sparking)	Clean and tighten.
Commutator out of round	Test; turn in lathe.

### MOTOR TROUBLES

#### DIRECT-CURRENT MOTORS

##### Fails to Start

1. Fuse out, causing an open circuit.
2. Brushes not making proper contact.
3. Line switch open.
4. Bearings "seized" due to lack of oil.
5. Motor overloaded. This will usually blow the fuse.
6. Open field circuit at the terminal block or in the starting box.  
"No voltage" release magnet burned out.
7. Open armature or line connections, either at the motor or controller.
8. Grounded winding, frequently blows the fuse.
9. Brushes not set on neutral point.
10. Armature wedged. Remove the wooden wedges from air gap of new machines.
11. Dirty commutator or brush faces.
12. High mica insulation on commutator preventing brush contact.
13. Field coils short-circuited or grounded. Will usually cause excessive armature currents and blow the fuses.
14. Reversed field connections. Test for polarity with a pocket compass.
15. Low voltage.
16. Pulley, gear, or coupling, may be tight against the bearing.
17. Bent shaft, causing armature to stick on pole faces.
18. Badly worn bearings allowing armature to rub field poles.
19. Burned out armature.

##### Starts Too Quickly

1. Starting box resistance too low for the motor.
2. Starting box resistance short-circuited.
3. Insufficient time allowed for starting.
4. Line voltage too high.
5. Series motor without enough load for the starting resistance used with it.
6. Too much resistance in field circuit.

## MOTORS

### Rotation Reversed

1. Reversed field connections.
2. Brush connections reversed or brushes in wrong position.
3. Compound motor connected differential and starts in reverse direction from the series field. Speed will be high and torque very low.
4. No field. Residual magnetism may start the motor in reverse direction on very light loads only. Motor will not start under heavy load.
5. Wrong field connection in starting box. Armature resistance may be in series with the field.

### Slow Starting and Weak Power

1. Low voltage.
2. Resistance of starting box too high.
3. Brushes off neutral, and will cause bad sparking.
4. Motor overloaded.
5. Heavy flywheel on driven machines.
6. Weak field due to resistance in its circuit.
7. Dirty or loose connections.
8. Dirty or loose brushes.
9. Brushes improperly spaced on commutator.
10. Armature defects, shorts, grounds or opens.
11. Wet armature or commutator.

### Bucking or Jerking

1. Overloaded motor.
2. Reversed interpole polarity.
3. Loose field connections which alternately open and close the field circuit and cause the motor to run jerkily.
4. Wet or shorted field coils.
5. Defects or loose connections in starting box.

### Overspeeds

1. Open field circuit, may cause dangerously high speed.
2. Shorted or grounded field coils.
3. Load suddenly reduced on compound motor using field control.
4. Brushes off neutral.
5. Shorted or grounded armature conductors.
6. Line voltage too high.
7. Series motor overspeeds on light loads or no load.

### Sparking at Brushes

1. Brushes or commutator dirty.
2. Rough or burned commutator.
3. High or low bars in commutator.
4. Commutator out of round.
5. Commutator segments shorted by carbon or copper dust in the mica slots, or by solder bridged across the bars.
6. High mica.

## MOTORS

### Sparking at Brushes (Cont'd)

7. Brushes off neutral.
8. Wrong type of brushes.
9. Brushes poorly fitted.
10. Brushes stuck in holders.
11. Poor or unequal brush tension.
12. Weak field, due to short circuits or grounds in the coils.
13. Reversed field coils.
14. Opens or shorts in armature winding. Opens usually cause long blue sparks and shorts are generally indicated by yellow or reddish sparks. The location of the defective coils will usually be indicated by burned bars to which they are connected.
15. Oil, grease or water on the commutator.
16. Unequal air gaps due to worn bearings.
17. Unbalanced armature winding.
18. Bent shaft which causes brushes to chatter.
19. Poor foundation, permitting vibration of the machine.

### Overheating

1. Overloading will cause heat on both motors and generators due to excessive current passing through their windings and brushes.
2. Excessive brush friction and brush tension too great.
3. Brushes of too high resistance.
4. Brushes off neutral.
5. Damp windings.
6. Excessive sparking at commutator, which may cause enough heat to melt the solder and loosen the armature connections.
7. Opens or shorts in armature winding.
8. Hot field coils caused by high voltage or short circuits in the coils.
9. Field shunts loose or disconnected.
10. Windings shorted by oil-soaked insulation.
11. Hot field poles may be due to poor design causing eddy currents in the pole shoes. Unequal air gaps may cause field poles closest to the armature to heat.
12. Hot bearings due to poor lubrication. May be caused by poor oil, stuck oil rings, or clogged oil wicks. Also caused by poor shaft alignment or excessive belt tension.
13. Armature out of center with field poles, due to worn bearings. Causes excessive currents in parts of the armature winding and eddy currents in the field poles. Bearings should be repaired immediately.
14. Clogged ventilating ducts.

## MOTORS

15. Loose connections between armature coils and commutator bars.
16. Weak field, not allowing sufficient counter-E.M.F. to be generated to keep the armature current normal.
17. Heat transfer through direct shaft connections from air compressors, steam engines or other machinery.

Normal operating temperatures of D. C. motors should not exceed 40° C. above the surrounding room temperature when operated at full load, or 55° C. at 25% overload for two-hour periods. If the machines are operated at temperatures above these values for any length of time, the insulation of the windings will become damaged and eventually destroyed. Safe operating temperature is about 140 to 150 degrees F.

### Unusual Noises

1. Belt slapping due to a loose, waving belt.
2. Belt squealing due to belt slipping on the pulley, caused by loose belt or overloads.
3. Brush squealing due to excessive spring tension, hard brushes, or dry commutator surface. Application of a good commutator compound will usually stop the squealing due to a dry unlubricated commutator.
4. Knocking or clanking may be caused by a loose pulley, excessive end play in the shaft, a loose key on the armature spider, or a loose bearing cap.
5. Chattering vibration, caused by poor brush adjustment and loose brushes, hard brushes, or commutator out of round.
6. Heavy vibration due to unbalanced armatures, bent shaft, or loose foundations.

### DIRECT-CURRENT MOTOR CONVERTED TO ARC WELDING GENERATOR

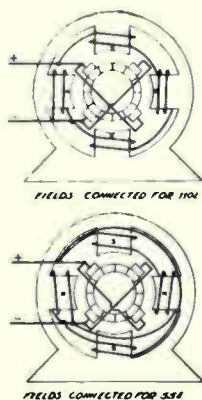
Direct-current motors of 10 to 20 h.p. may be converted into welding generators with little difficulty, providing they are compound wound machines. Some motors may be adapted to this application by installing a series winding and providing separate excitation. The most desirable type of machine for welding conversion, and the one that presents the least difficulty in making the change, is a 110-volt 10 h.p. or 15 h.p. compound type motor. To adapt such a motor to welding work requires two necessary changes:

First, change the armature winding from a simplex to a duplex connection; second, reconnect the shunt field coils, so that the normal voltage is imposed upon each coil when 55 volts is applied to the field. (See Fig. 13-18.) Changing the armature winding from

## MOTORS

simplex to duplex will half the armature voltage and double its current carrying capacity. Reconnecting the shunt field coils will insure normal field strength at the reduced voltage. After the above changes have been made, the 10 h.p. motor should deliver about 150 amps. at 55 volts, and the 15 h.p. unit will deliver approximately 240 amperes.

Before any changes on the armature are attempted, the winding should be carefully examined to see whether it is lap or wave wound. If it is wave wound, the current carrying capacity of the armature may be doubled by changing the winding of a lap connection; if it is lap wound, the connection must be changed from simplex to duplex. Either of these changes doubles the number of paths through the armature, assuming the machine to have four poles, which is usually the case for motors of 10 h.p. to 15 h.p. rating. It is better, as a general rule, to change the winding from simplex to duplex, regardless of whether it is lap or wave wound, since this change involves but little movement of the coil leads, and lessens the chance of breaking the wires; moreover, this method may be applied to either lap or wave windings.



**Fig. 13-18.** The above diagram shows how the field coils may be reconnected so as to maintain a normal field strength on half the original voltage. The top drawing shows all four coils connected in series and the drawing on the bottom shows the two series groups connected in parallel with each other.

The change is made by raising all of the top coil leads and moving them over a distance of one commutator bar. This is shown in the sketches "A" and "B" of Fig. 13-19. Note that in sketch "A," which



## MOTORS

shows the ordinary lap connection, the top lead "X" is connected to bar 2; "Y" is connected to bar 3; "Z" is connected to bar 4; and so on. After the change, the top lead "X" is connected to bar 3; "Y" is connected to bar 4; and "Z" to bar 5, as in figure 2B, and so on for all the other leads. This really amounts to merely moving all the top leads over a distance equal to one commutator bar. Note, too, that the bottom leads are undisturbed.

The same procedure is employed with a wave winding, except that with this type an odd number of commutator bars is sometimes employed. The odd bar may be eliminated by joining it to an adjacent bar and treating these two as one bar; the extra coil in this case must be left out of the circuit. In any case, before such a change is attempted, a complete diagram of the armature winding should be made, showing the connections both before and after the change, and the winding should be carefully traced.

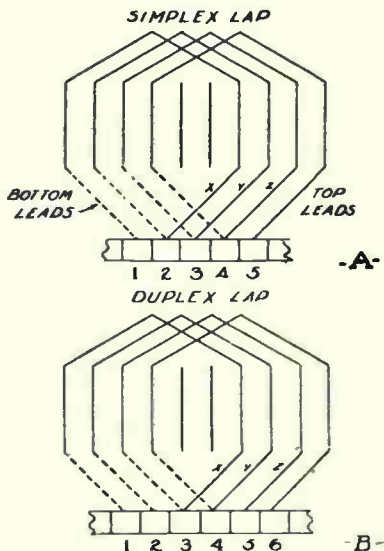


Fig. 13-19. The above diagram shows how the current capacity of an armature may be doubled by changing the coil connections from simplex lap to duplex lap.

This procedure will eliminate the confusing mistakes that sometimes follow an attempted change of this sort, as it is much easier to check connections on a diagram than on the actual machine.

## MOTORS

An easier conversion than the above may be accomplished by separately exciting the field from a suitable D. C. source, such as a farm lighting plant, and reconnecting the fields if necessary. With such an arrangement at 15 h.p., 110-volt motor, will deliver over 200 amperes without any change in the armature winding. Such a welder could be driven by an engine of a Model "A" Ford, with some other suitable engine.

Should the machine be a compound type, the series field winding is usually connected differential, although both connections should be tried, as, due to the variations in design on different machines, it may be found that the cumulative connection gives better results.

Should the shunt field be separately excited, differential connection of the series field would generally produce the most satisfactory results. To give the welding circuit the falling voltage characteristic that is essential to such applications, it is necessary to place a resistor in series with the positive welding lead. This resistor should be capable of carrying—for reasonable intervals of time—the full load current of the machine, and should, if the welder is to be used on a variety of work, be adjustable. That is, arrangement may be made to short circuit sections of the resistors when heavy currents are carried. For the 10 h.p. machine a  $\frac{1}{2}$  ohm resistor tapped as shown in figure 3, should be suitable, and for the 15 h.p. machine a  $\frac{1}{3}$  ohm unit tapped in a similar manner may be employed. In case the arc is somewhat unsteady or unstable, increasing the series resistance will usually remedy the trouble.

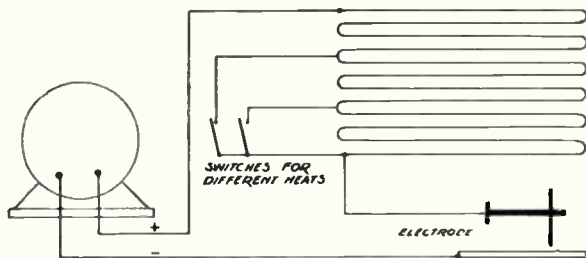


Fig. 13-20. The above diagram shows how a resistance unit consisting of several lengths of iron pipe may be used with a welding generator. The diagram shows the positive lead connected to the electrode but as previously explained, this connection depends on the nature of the work.

## MOTORS

The resistor may be composed of 8 or 10 lengths of  $\frac{1}{4}$ -inch iron pipe, screwed together and bent into the form shown by Fig. 13-20. This arrangement is compact and has current-carrying ability great enough for the purpose. Moreover, should prolonged operation cause undue heating, arrangements can be made for circulating water through the pipe.

With reasonable care in changing the connections as explained, and with a little experimental adjustment of the field strength and the load resistor, these converted D. C. motors can often be made to operate quite effectively as electric arc welding generators. Many profitable welding and repair jobs can usually be found for such a machine.

## Section 14

# GENERATORS — CONVERTERS — RECTIFIERS

### GENERATORS

**Rotation and Current Direction.** Extend the thumb, forefinger and middle finger of your right hand so that they are at right angles to one another, so that each is at right angles to the other two. When your forefinger points in the direction of magnetic flux across armature or rotor conductors, and when your thumb points in the direction of conductor movement, your middle finger will point in the direction of current flow through the conductor.

**Speed and Frequency.** A conductor in a generator must always pass one pair of poles, or one north and one south pole, to complete a cycle. Therefore, the greater the number of poles in a generator the greater will be the number of cycles it will produce per revolution. The frequency of any a-c generator can always be determined by the following simple formula:

$$f = \frac{\text{RPM}}{60} \times N$$

In which:

f = frequency in cycles per second

RPM = revolutions per minute of generator

60 = no. of seconds per min.

N = no. of pairs of poles in generator

**A-C Generator Terminal Markings.** American Standard terminal markings for single-phase generators are as shown by Fig. 14-1.

Three-phase a-c generators have terminal markings like those for three-phase induction motors.

Two-phase a-c generators have terminal markings like those for two-phase induction motors.

### D-C GENERATOR TROUBLES

#### Failure to Build Up Voltage

1. Residual field lost or neutralized.
2. Reversed field.
3. Poor brush contact or dirty commutator.
4. Open field circuit due to loose connections or broken wires.
5. Field rheostat open or of too high resistance.
6. Series field reversed so it opposes the shunt field.
7. Shunts disconnected or improperly connected.
8. Wet or shorted field coils.

## GENERATORS — CONVERTERS — RECTIFIERS

9. Too heavy load on a shunt generator.
10. Residual magnetism reversed by flux from nearby generators.

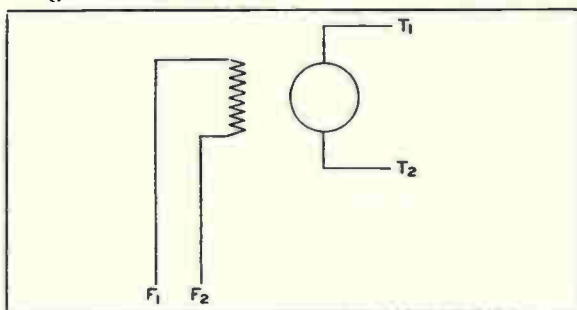


Fig. 14-1

### Poor Voltage Regulation

1. Loose field shunts or connections.
2. Poor regulation of engine speed.
3. Belt slipping (if generator is belt driven)
4. Brushes off neutral.
5. Improper resistance of field rheostat, or loose connections at this rheostat.
6. Series field shunts not properly adjusted.
7. Overheated field coils.
8. Loose or grounded field wires between generator and switchboard.
9. Armature out of center.
10. Brushes improperly spaced.
11. Weak field caused by short circuits or grounds in the field windings.
12. Shorts, opens, or grounds in the armature coils.
13. Excessive and frequent variations in load.
14. Improper compounding.

### Will Not Operate in Parallel

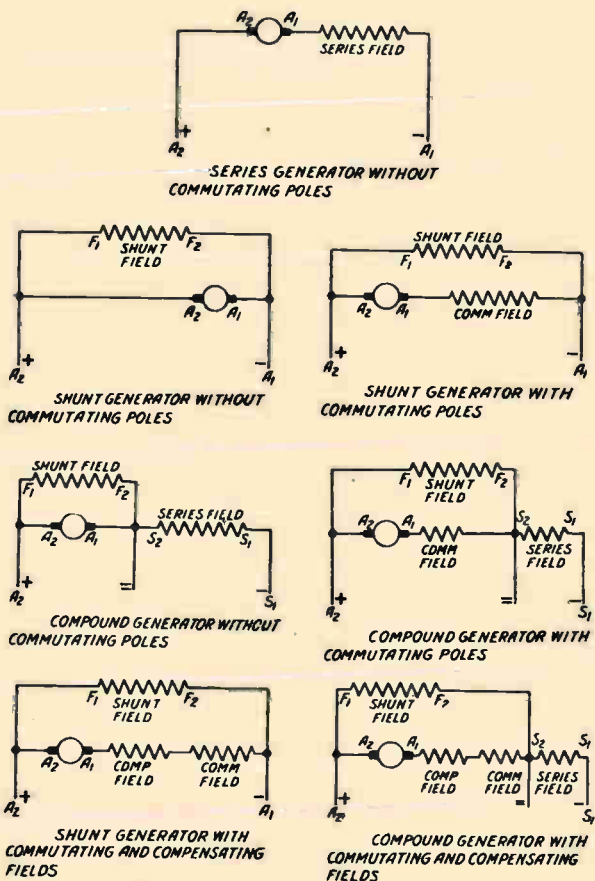
1. Poor speed regulation on prime mover, caused by improper governor adjustment.
2. Open equalizer connections.
3. Incorrect field shunts, open or loose field connections, or weak fields.
4. Defective field rheostat.
5. Wet field coils.
6. Improper adjustment of series fields for compounding effects.
7. Extreme difference in size, causing the smaller machine to be more responsive to load changes than the larger machine.
8. Belt slipping, on belt-driven generators.

# GENERATORS — CONVERTERS — RECTIFIERS

## DIRECT-CURRENT GENERATORS

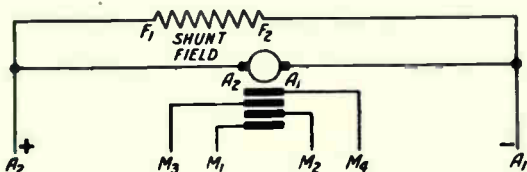
### Connections and Terminal Markings

### TWO-WIRE TYPES

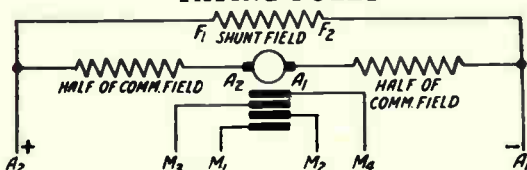


**Fig. 14-2. American Standards**  
Standard direction of shaft rotation is clockwise, facing end  
opposite the drive.

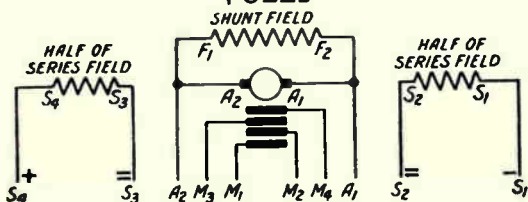
**GENERATORS — CONVERTERS —  
RECTIFIERS**  
**DIRECT-CURRENT GENERATORS**  
Connections and Terminal Markings  
**THREE-WIRE TYPES**



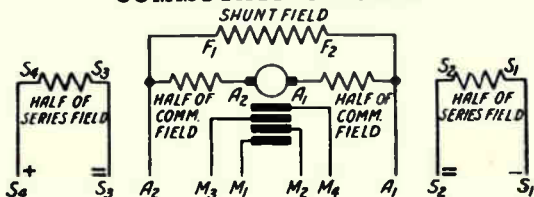
**SHUNT GENERATOR WITHOUT COMMUTATING POLES**



**SHUNT GENERATOR WITH COMMUTATING POLES**



**COMPOUND GENERATOR WITHOUT COMMUTATING POLES**



**COMPOUND GENERATOR WITH COMMUTATING POLES**

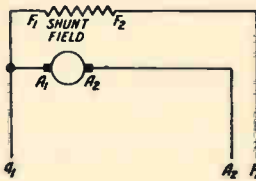
**Fig. 14-3. American Standards**  
Standard phase and rotor rotation is clockwise, facing the end opposite the drive.

# GENERATORS — CONVERTERS — RECTIFIERS

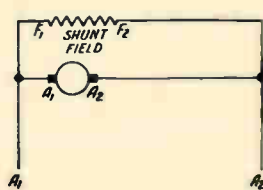
## DIRECT-CURRENT GENERATORS

### Connections and Terminal Markings

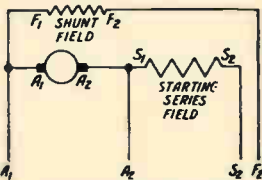
### FARM LIGHTING PLANTS



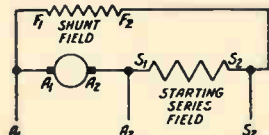
**SHUNT GENERATOR**



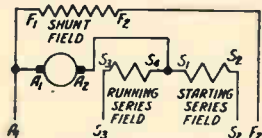
**SHUNT GENERATOR**



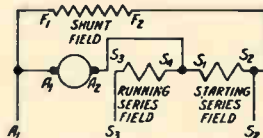
**SHUNT GENERATOR WITH  
STARTING SERIES FIELD**



**SHUNT GENERATOR WITH  
STARTING SERIES FIELD**



**COMPOUND GENERATOR WITH  
STARTING SERIES FIELD**



**COMPOUND GENERATOR WITH  
STARTING SERIES FIELD**

**Fig. 14-4. American Standards**  
Standard direction of shaft rotation is counter-clockwise, facing the end opposite the drive.

9. Variations in steam pressure, on generators driven by steam engines.
10. Defective voltmeter, causing operator to make wrong adjustment.

**Three-Wire System.** A direct-current supply system in which the voltage from one wire, called the neutral, to either of the others is half that which exists between the other two wires. For example, the voltage from the neutral to either of the "outside wires" may be 110, and between the two outside wires may be 220. See Fig. 14-5.



## GENERATORS — CONVERTERS — RECTIFIERS

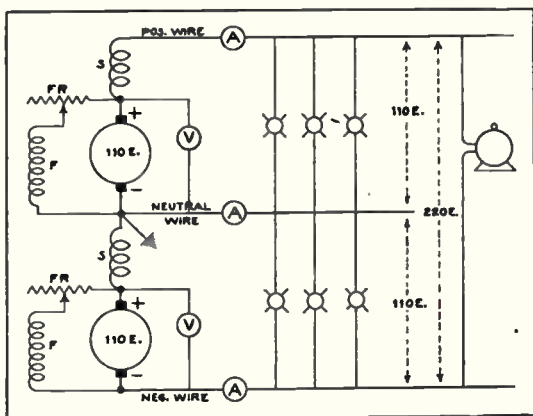


Fig. 14-5

## CONVERTERS

**Converter.** A rotating machine for changing electrical energy from one form to another. A rotary converter, a frequency converter, an inverted converter, etc.

**Synchronous Converter.** A rotating machine for changing alternating current to direct current, or direct current to alternating current. There is a single armature carrying alternating-current slip rings and a direct-current commutator.

**Rotary Converter.** A synchronous converter.

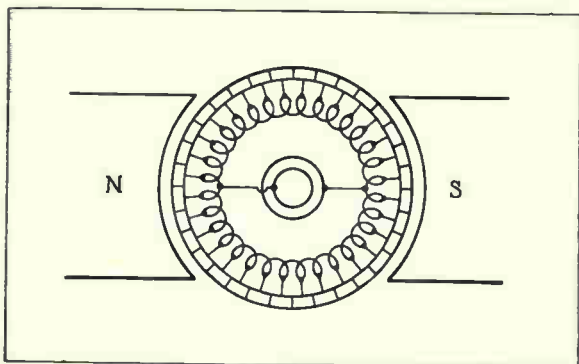
**Inverted Converter.** A synchronous converter for changing direct current to alternating current.

**Frequency Converter.** A machine for changing one alternating-current frequency to another frequency.

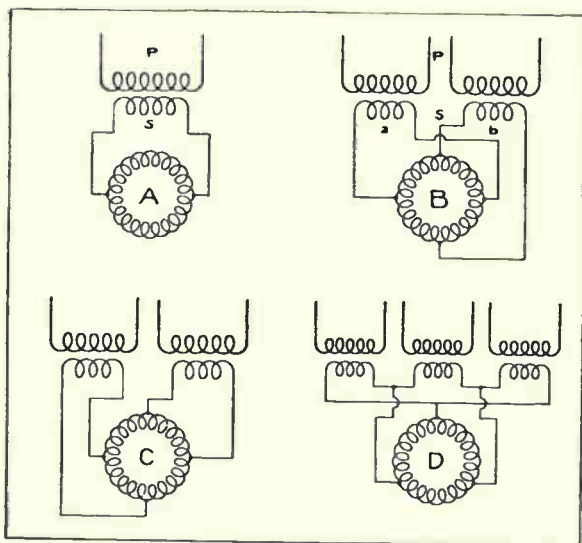
**Dynamotor.** A rotating machine for changing direct-current voltages, or for changing direct current to alternating current of desired frequency and voltage. There is a common magnetic circuit with two armature windings and two commutators or sets of slip rings.

**Motor-Generator.** An electric motor directly connected to one or more generators for the purpose of converting a power line voltage to other desired voltages or frequencies.

## GENERATORS — CONVERTERS — RECTIFIERS



**Fig. 14-6.** Diagram of the armature connections for a simple two-pole, single-phase, synchronous converter. Note that the slip ring connections are taken at points 180 electrical degrees apart on the winding.



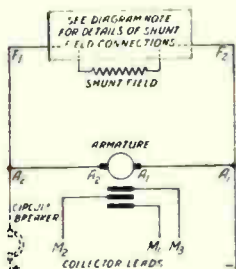
**Fig. 14-7.** A. Transformer connections for a single-phase converter. B. Transformer connections for a two-phase, d-a-metric converter. C. Transformer connections for a two-phase, adjacent tap converter. D. Transformer connections for a three-phase converter. The armature connections in all of the above diagrams are for two-pole machines.

# GENERATORS — CONVERTERS — RECTIFIERS

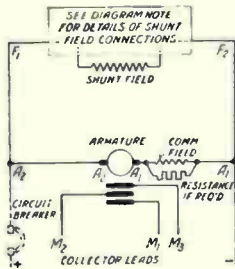
## SYNCHRONOUS CONVERTERS

### Connections and Terminal Markings

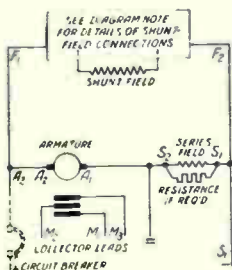
Note: For shunt field connections see Fig. 14-9



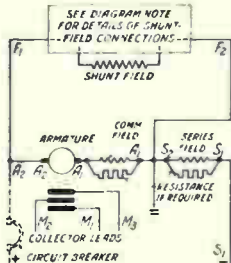
SHUNT-WOUND THREE-PHASE SYNCHRONOUS CONVERTER WITHOUT COMMUTATING POLES



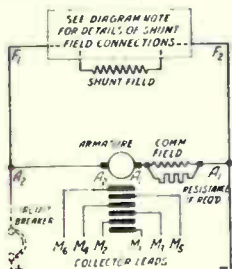
SHUNT-WOUND THREE-PHASE SYNCHRONOUS CONVERTER WITH COMMUTATING POLES



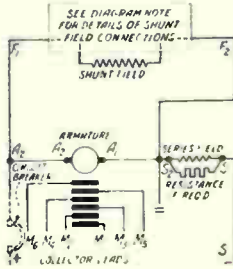
COMPOUND-WOUND THREE-PHASE SYNCHRONOUS CONVERTER WITHOUT COMMUTATING POLES



COMPOUND-WOUND THREE-PHASE SYNCHRONOUS CONVERTER WITH COMMUTATING POLES



SHUNT-WOUND SIX-PHASE SYNCHRONOUS CONVERTER WITH COMMUTATING POLES



COMPOUND-WOUND SIX-PHASE SYNCHRONOUS CONVERTER WITHOUT COMMUTATING POLES

Fig. 14-8. American Standards

# GENERATORS — CONVERTERS — RECTIFIERS

## SYNCHRONOUS CONVERTERS

### Shunt Field Connections

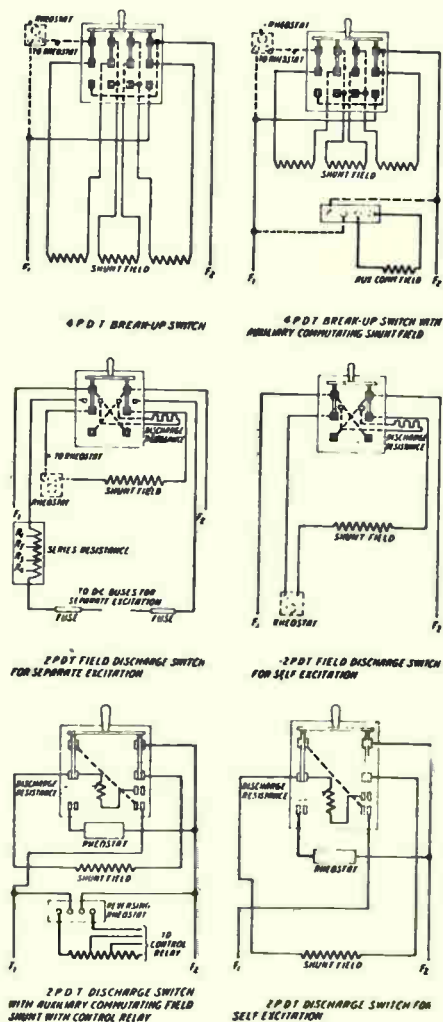


Fig. 14-9. American Standards

# GENERATORS — CONVERTERS — RECTIFIERS

## RECTIFIERS

**Rectifier.** A device which changes an alternating current into a pulsating direct current. It may be a vacuum tube, gaseous tube, vibrator or copper-oxide device.

**Half-Wave Rectifier.** A device which converts alternating current into pulsating direct current by allowing current to pass only during one half of each alternating current cycle.

**Full-Wave Rectifier.** A device which rectifies an alternating current in such a way that both halves of each input a.c. cycle appear in the pulsating rectified output.

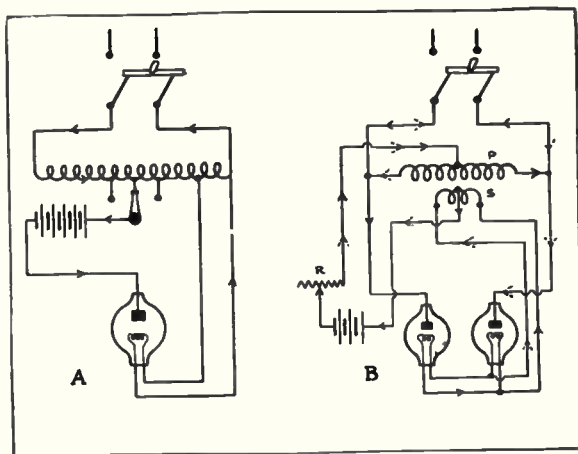


Fig. 14-10. A. Shows a circuit of a simple half-wave rectifier of the bulb type, and B shows the circuit of a full-wave rectifier using two bulbs.

**Copper-Oxide Rectifier.** A rectifier made up of discs of copper coated on one side with cuprous oxide. The discs allow direct current to flow in one direction but allow very little current flow in the reverse direction.

## GENERATORS — CONVERTERS — RECTIFIERS

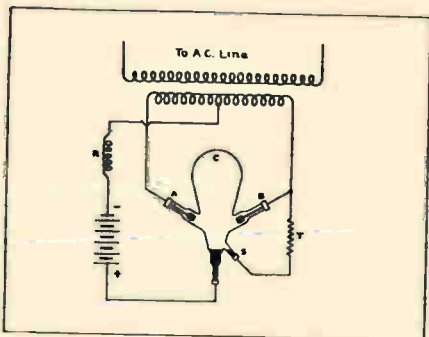


Fig. 14-11. Circuit diagram of a bulb type mercury arc rectifier used for battery charging purposes.

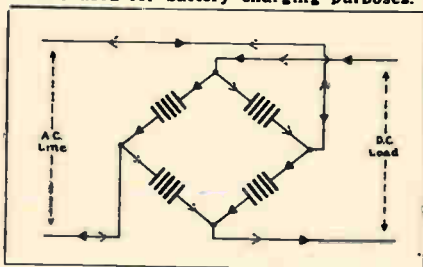


Fig. 14-12. Connection diagram of a full-wave, copper oxide rectifier with four units connected in a "bridge" type circuit.

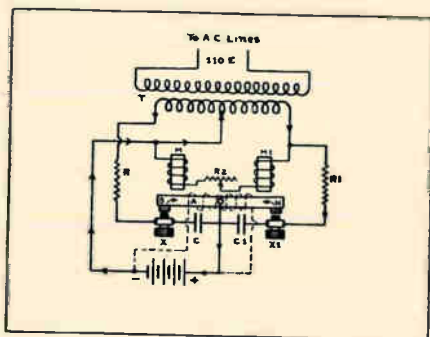


Fig. 14-13. The above diagram shows the parts and connections of a simple mechanical rectifier of the vibrating type. The synchronous operation of the contacts delivers pulsating D.C. to the battery circuit.

## Section 15

# BATTERIES

### DEFINITIONS

**Cell.** A single unit capable of serving as a d.c. voltage source. A primary cell, such as a dry cell, cannot be recharged when exhausted. A secondary cell, such as the cell of a storage battery, can be recharged when exhausted by passing a current through it in the reverse direction.

**Battery.** One or more dry cells or storage cells connected together to serve as a d.c. voltage source.

**Primary Cell.** A voltaic cell or battery cell in which, when current is produced, the chemicals of the cell elements are consumed or changed to such forms that they cannot be restored to their original active condition by sending a reverse current through the cell, thus making the cell useless after having delivered a certain number of ampere-hours of electricity.

**Dry Cell.** A primary cell having a zinc outer can as its negative electrode, a central carbon rod as its positive electrode, and a liquid electrolyte of a small quantity of sal ammoniac and zinc chloride held in an absorbent lining and in a mass of powdered graphite and manganese dioxide, these latter two materials being the depolarizer. The cell is sealed. Its voltage is approximately 1.5.

**Polarization.** Reduction of the terminal voltage of a cell, due to formation of hydrogen gas on the surfaces of the cell electrodes and to the accompanying counter-emf produced in the cell.

**Secondary Cell.** A d.c. voltage source which is capable of storing electrical energy. When exhausted, it can be recharged by sending direct current through it in the reverse direction. Each cell of an ordinary storage battery is a secondary cell.

**Storage Cell.** A secondary cell. More specifically, one of the cells of the ordinary automotive storage battery, delivering a voltage slightly higher than two volts and capable of being recharged.

**Storage Battery.** One or more secondary, or storage cells connected together, usually in series.

**Lead-Acid Battery.** A storage battery in which the plates for the cells have active materials of sponge lead and lead peroxide, and in which the electrolyte liquid is a mixture of sulphuric acid and water. The most common type of storage battery.

**Electrolyte.** The liquid or chemical paste which is used between the electrodes of a dry cell or storage battery.

## BATTERIES

**Hydrometer.** A weighted hollow bulb with an extended graduated stem which, when partially immersed in a liquid sinks to a level such that the specific gravity of the liquid is indicated on the stem.

**Specific Gravity.** The ratio of the weight or mass of a substance to the weight or mass of an equal volume of pure water at the same temperature, or sometimes at a reference temperature of four degrees centigrade.

**Sulphation.** In a lead-acid storage battery, the conversion during discharge of an excessive amount of the active sponge lead and peroxide of lead into inactive sulphate of lead.

**Ampere-Hour.** A current of one ampere flowing for one hour. This unit is used chiefly to indicate the amount of electrical energy a storage battery can deliver before it needs recharging.

**Alkali-Type Battery.** A storage battery using an alkaline or non-acid liquid electrolyte; an Edison battery.

### LEAD-ACID BATTERIES

Mixing of electrolyte should be done in an acid-proof container of hard rubber, glass, earthenware, or lead. A wooden paddle or glass rod should be used to stir the solution. Don't use metals for this purpose.

The electrolyte should be allowed to cool below 90° F. before being put in battery cells.

MIXING ELECTROLYTE BY VOLUME					
WATER			DILUTED ACID		Sp. Gr. OF ELECTROLYTE
ADD	3%	PINTS	TO 1 GAL. OF	1.400 ACID	FOR 1.300 ELECTROLYTE
"	4 1/2	"	"	"	" 1.280 "
"	8	"	"	"	" 1.275 "
"	9 1/2	"	"	"	" 1.260 "

The amount, by volume, of water and acid to be mixed together to produce battery electrolysis of four different strengths.

BATTERY CONDITIONS INDICATED BY GRAVITY TESTS		
1.150 Sp. Gr.-----DEAD	}	AUTO BATTERIES IN TEMPERATE CLIMATES
1.215 Sp. Gr.-----1/2 CHARGE		
1.280-1.300 Sp. Gr.-----FULL "		
1.200 Sp. Gr.-----FULL CHARGE	}	AUTO BATTERIES IN TROPICS
1.225 Sp. Gr.-----" "		
		ELECTROLYTE TEMPERATURE AT 70° F.

Conditions of charge indicated by various hydrometer readings on lead plate storage batteries in different climates.



## BATTERIES

MIXING TABLE			
SPECIFIC GRAVITY OF SOLUTION OR ELECTROLYTE AT 70° F.	PARTS OF WATER TO 1 PART OF C.P. SULPHURIC ACID 1.835 SP. GR. AT 70° F.		PERCENTAGE OF SULPHURIC ACID IN SOLUTION
	BY VOLUME	BY WEIGHT	
1.120	8.00	4.40	17.40
1.150	6.15	3.35	21.40
1.180	4.95	2.70	25.20
1.200	4.33	2.36	27.70
1.220	3.84	2.09	30.20
1.250	3.22	1.76	33.70
1.270	2.90	1.57	36.10
1.280	2.75	1.49	37.30
1.300	2.47	1.34	39.85
1.350	1.95	1.06	45.20
1.400	1.56	0.84	50.50

The amounts, both by volume and by weight of water and full strength acid which should be mixed together to produce electrolysis of different specific gravities.

**Temperature Corrections.** A convenient rule to use in making temperature corrections when a correction thermometer is not available but the temperature of the battery or electrolyte is known is as follows:

For every three degrees above 70° F. one point is added to the hydrometer reading, and for every three degrees below 70° F. one point is subtracted from the hydrometer reading.

For example, if we have electrolyte at a temperature of 100° F. and the hydrometer shows a reading of 1.270, then the electrolyte temperature being 100°, or 30° above 70°, we will divide 30 by 3 and find that 10 points must be added for correction of the hydrometer reading. Then 1.270 plus 10 = 1.280 or the correct gravity reading.

**Voltage Test.** While the hydrometer test must be used to determine the condition of the electrolyte and is generally a rather good indication of the state of charge of a battery, it is not altogether reliable for this latter purpose.

There should always be a definite relation between the voltage of a cell and the specific gravity of its electrolyte, but in some cases the gravity of the electrolyte may have been altered by adding strong acid or by replacing a large quantity of spilled electrolyte with distilled water.

In either of these cases a gravity reading would not be an accurate indication of the true condition of the cell. So a voltage test made by connecting the terminals of a low-reading voltmeter across a cell or battery is a more reliable means of determining whether the battery is fully charged or not.

## BATTERIES

The **on-the-line** voltage test is made while the battery is connected in the charging line and charging. At the end of the charge or when the cell is about fully charged the maximum cell voltage on this test will be about 2.5 volts. This voltage indicates a complete chemical change of the material in the plates. Old batteries often do not rise above 2.3 volts per cell on this test due to the negative plates retaining some of their lead sulphate.

Once the voltage of the cell reaches 2.5 volts there can be no further rise of gravity since the plates are free from lead sulphate. If the gravity is below or above the full charge specific gravity of the cell it should be corrected by adding acid or water accordingly.

**High-rate Discharge Test.** The condition of automotive batteries may be checked by discharging them at a high rate for a few moments while voltage readings are taken of each cell.

For making this test some form of high rate discharge test set is generally used. These sets consist of a variable resistance, generally of the carbon pile type, an ammeter of sufficient capacity, and a voltmeter.

The discharge rate for making these tests is based on the number of plates per cell, the usual rate being 20 to 25 amperes per positive plate, figuring only the positive plates in one cell.

For example an 11-plate battery having eleven plates per cell would have 6 negatives and 5 positives in each cell. As the discharge rate is based on the number of positives the high rate discharge current for testing such cells would be  $5 \times 20$ , or  $5 \times 25$ , or 100 to 125 amperes.

While the battery is discharging at this rate the voltage of each cell is measured separately, and if the battery is in good condition and fully charged the voltage should not drop below 1.75 or 1.78 volts per cell during the test. This voltage drop is caused by the heavy current flowing through the internal resistance of the cell.

Excessive voltage drop may be due to several causes such as spongy or worn out plates, clogged separators, or wrong specific gravity of the electrolyte.

Thin and worn separators may also be the cause of large voltage drop by allowing the plates to be short circuited during heavy discharge tests.

The exact readings obtained on this test are not as important as the difference in readings between the several cells. A cell that gives a reading of more than .1 volt less than the other cells is generally defective and should be opened and examined.

## BATTERIES

Sometimes a high rate discharge test will cause one cell to give a reverse reading which indicates that the cell is shorted.

**Cadmium Test.** The cadmium test for lead-acid storage batteries is applied by inserting a stick or rod of the metal cadmium into the electrolyte, then reading the voltages between the cadmium and the positive plates and between the cadmium and the negative plates.

Cadmium tests should be made only with the battery on charge at the regular charging rate. The test lead to which the cadmium stick is attached should always be connected to the negative terminal of the voltmeter, while the plain test lead to be used on the cell terminals is to be connected to the positive terminal of the meter.

With the battery on charge the cadmium stick is inserted through the vent hole of the cell cover until it makes good contact with the electrolyte. The cadmium stick must not touch the plates and for this reason many of these sticks are equipped with insulating tips or with a perforated rubber tube over their ends.

The cadmium should remain in the electrolyte for a minute or two before taking the readings so that a thin coating of cadmium sulphate will form on the stick. The other test point can then be shifted between the positive and negative cell terminals to make the tests.

By attaching it to the negative terminal the condition of the negative plates can be determined, and when it is in contact with the positive terminal the condition of the positive plates can be determined by the voltmeter readings.

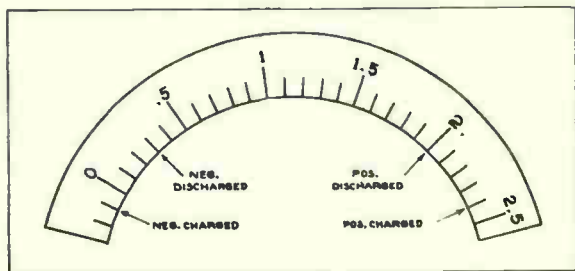


Fig. 15-1

## BATTERIES

With the battery on charge the voltage reading between the cadmium stick and the positive terminal will be about 2.4 volts if the positive plates are pure lead peroxide or fully charged. See Fig. 15-1.

With the free test point on the negative terminal a reading of .1 volt to the left of zero will be obtained if the negative plates are pure sponge lead or fully charged.

If these two readings are added together their sum should equal the reading of a voltage test taken from positive to negative terminals. These voltages would indicate that both positive and negative plates are fully charged and in good condition.

If when making such a test the positive reading was 2.4 volts and the negative reading to the right of zero, the voltage of the cell would be obtained by subtracting the negative reading from the positive reading. Such a test would indicate that the negative plates are in bad condition since they are not charged while the positives are.

**Charging Rates.** There are two general methods in use for charging batteries, one known as the constant current method and the other as the constant potential method.

The constant current method is sometimes known as series charging, because all of the batteries are connected in series and are all charged at the same current rate regardless of their size or condition. With this system about the same charging rate in amperes is maintained from start to finish of the charging period.

Constant potential charging systems generally use a motor-generator set for changing A. C. to D. C., and all of the batteries are connected in parallel directly across the low voltage D. C. generator bus bars. This system is sometimes called parallel charging, as the batteries are all connected in parallel and each battery forms an individual or separate circuit between the positive and negative busses.

Charging rates depend largely on the size of the battery and the type of equipment used. In commercial charging it is not always practical to regulate the current to suit each individual battery and in cases of this kind a rate is used that best suits the average battery.

Where the charging current can be regulated a good rule to determine the charging rate for any certain battery is to start charging at  $\frac{1}{8}$  of its rated capacity in ampere hours, and when it is a little over one-half charged reduce this rate to one-half the starting rate.

## BATTERIES

For example, if the capacity of a battery is 80 ampere-hours, the charging rate at the start for constant current charging would be  $\frac{1}{8}$  of 80, or 10 amperes and the finishing rate about 5 amperes. The reason for reducing the charging rate toward the finish of the charge is to prevent overheating of the plates, as the amount of lead sulphate and acid in the plates and being worked upon by the charging current is gradually being reduced, and the heavy charging current would develop too much heat.

In constant current or series charging it is not possible to regulate the current to suit individual batteries, since they are all connected in series and the same amount of current flows through each.

**The temperature of the batteries should never be allowed to exceed 110° F. during charging** and temperature tests should always be made on a cell in the center of the battery, as these cells tend to heat more than the outer ones because of poor ventilation, due to the fact that they are between the outer cells.

**Constant Potential Charging.** A constant potential charger consists of a motor-generator set, the motor being either D. C. or A. C. and designed for 110 or 220 volts, according to the available supply, and the generator producing direct current at  $7\frac{1}{2}$  volts for charging 6-volt batteries, or 15 volts for charging 12-volt batteries.

When a completely discharged battery is placed on a constant potential system the charging current at the start may be 20 amperes or more but will rapidly taper off as the battery voltage increases, dropping down to as low as 2 or 3 amperes when the battery becomes fully charged.

The charging rate is limited only by excessive heating, and when any battery overheats the charging rate should be reduced by connecting a resistance in series with one of the leads to that particular battery. Convenient small resistance units equipped with a clip at the lower end for attaching direct to the battery terminal are obtainable for this use.

When operating constant potential battery chargers the following simple rules would be well to keep in mind:

1. Batteries must be connected in parallel across the bus bars, with the positive terminal of each battery connected to the positive bus and negative terminals to negative bus. When the generator is idle the main switch on the control panel must be opened before connecting batteries.

2. When starting the machine the motor of the M-G set is first started and allowed to come up to speed. The voltage is then regulated by means of the gen-

## BATTERIES

erator rheostat and is set at 7.5 volts for charging 6-volt batteries. This voltage adjustment is very important and must not be neglected.

3. When the voltmeter registers 7.5 volts the main switch on the control panel can be closed, completing the charging circuit and starting the batteries charging.

4. If it is necessary to stop the set for any reason, first open the main switch on the control panel in order to prevent the batteries from feeding current back through the idle armature of the generator. It is also advisable to disconnect the battery leads or open the individual battery switches when provided, and thus disconnect the batteries from the bus bars, or otherwise current will circulate between the batteries. This is caused by the ones which are of higher voltage or nearer to full charge discharging through the ones that are of lower voltage or have not been on charge as long.

### DRY CELLS AND BATTERIES LARGE DRY CELLS

Usual performance of one No. 6 dry cell; 2½ inches diameter, 6 inches high.

#### Continuous Discharge At ¼ Ampere

Hours	End Voltage	Hours	End Voltage
10	1.30	50	1.00
20	1.22	60	.88
30	1.17	70	.75
40	1.10	80	.58
Watt- Hours	End Voltage	Watt- Hours	End Voltage
5	1.25	15	1.00
10	1.15	20	.70

#### Continuous Discharge To End Voltage of 1.00 Volt

Discharge Rate Amperes	Total Discharge Ampere-hours	Hours for Discharge
0.1	26.0	260
.15	19.8	132
.2	16.7	83
.3	13.1	44
.4	10.9	27
.5	9.6	19
.6	8.6	14½
.7	8.0	11½

## BATTERIES

### FLASHLIGHT CELLS

Type	Diam. Length Inches	Number of Intermittent Tests	Continuous Discharge, Minutes
A	$\frac{5}{8} \times 1\frac{7}{8}$	12	25
B	$\frac{3}{4} \times 2\frac{1}{8}$	26	65
C	$15/16 \times 1\ 13/16$	42	90
D	$1\frac{1}{4} \times 2\frac{1}{4}$	100	380
E	$1\frac{1}{4} \times 2\frac{7}{8}$	150	550
F	$1\frac{1}{4} \times 3\ 7/16$	180	800

Intermittent tests: Discharge through 4 ohms for 5 minutes each 24 hours. End volts = 0.75.

Continuous discharge: Through 4 ohms to end voltage of 0.75 volt.

## Section 16

# SWITCHING AND CONTROL

### DEFINITIONS

**Switch.** A mechanical device for opening and closing an electrical circuit, or for changing the connections between parts or circuits.

**Single-Pole Switch.** A switch having but one pair of contacts, which will open and close only one line or one circuit.

**Double-Pole Switch.** A switch which simultaneously opens or closes two separate circuits or both sides of the same circuit.

**Single-Throw Switch.** A switch which opens and closes in only one direction, which connects one line or one circuit to only one other line or circuit.

**Double-Throw Switch.** A switch which opens and closes in either of two directions, which connects one line or circuit to either of two other lines or circuits.

**Three-Way Switch.** A switch that connects one of its terminals alternately to two other terminals, used in a circuit for controlling a single load from two different locations.

**Four-Way Switch.** A switch used in a circuit that permits a single load to be controlled from any of three or more positions. The switch has four terminals which alternately are joined together in different pairs.

**Knife Switch.** A switch in which one or more flat metal blades, each pivoted at one end, serve as the moving parts. The blades are usually of copper; when the switch is closed, they make contact with flat gripping spring clips and complete the circuit.

**Snap Switch.** A switch in which movement of the control member first places tension on a spring, after which the spring tension is released to suddenly open (and usually to suddenly close) the switch contacts.

**Toggle Switch.** A small switch operated by means of a lever.

**Gang Switch.** Two or more rotary switches mounted on the same shaft and operated by a single control.

**Drum Switch.** A switch whose circuit-connecting parts are fingers held by spring pressure against contact segments or surfaces carried on the outside of a rotating cylinder or part of a cylinder.

**Motor-Circuit Switch.** A switch that will open the maximum operating current of a motor, the switch being rated in horsepower which is the same as that of the motor.



## SWITCHING AND CONTROL

**Isolating Switch.** A switch intended for isolating an electric circuit from the power source; to be operated only when the circuit has been opened by some other means.

**Master Switch.** A switch that governs the operation of a controller by actuating its contactors and auxiliary devices.

**Controller.** Any device or group of devices governing the electric power delivered to apparatus to which the controller is connected.

**Full-Magnetic Controller.** A controller in which electro-magnets control all the basic functions such as closing and opening the line circuit, reversing, retarding and accelerating.

**Semimagnetic Controller.** A controller in which part of the basic functions are performed by electro-magnets and part by hand or other means.

**Manual Controller.** A controller in which all the basic functions (off, on, reversing, etc.) are performed by hand operation.

**Drum Controller.** A controller which uses a drum switch as its principal switching element.

**Contactors.** A magnetically operated switch for opening and closing circuits carrying large currents.

**Motor Starter.** A hand-operated or magnetically operated contactor or heavy-duty switching device for opening and closing the circuit feeding a motor or motors as the motors are stopped and started.

**Relay.** A device, usually electromagnetic, which is itself operated by conditions in one electric circuit, and which effects operation of other devices in the same circuit or another circuit.

**Undervoltage Release.** Means which, upon failure or reduction of voltage, interrupts power to the main circuit, but does not prevent again completing the main circuit on return of voltage.

**Undervoltage Protection.** Means which, upon the failure or reduction of voltage, interrupts power to the main circuit and maintains the interruption.

**Controller Duty.** The length of time of operation of a controller and the number of operations in a given time period. Also the function of a controller; as starting and stopping, reversing, speed control, etc.

**Continuous Duty.** A type of service in which the electric machine operates at substantially constant load for an unlimited period.

**Periodic Duty.** A type of service in which there are alternating periods of load and rest, with the load repeating in a uniform manner and quantity.

## SWITCHING AND CONTROL

### THREE-WAY AND FOUR-WAY SWITCHES

**Fig. 16-1.** Approved method of using two 3-way switches to control lamps or other loads from two places. **Fig. 16-2.** Another two-place control. **Fig. 16-3.** One 4-way and two 3-way switches controlling loads from three places. **Fig. 16-4.** One 3-way and two 4-way switches control each load alternately from three places.

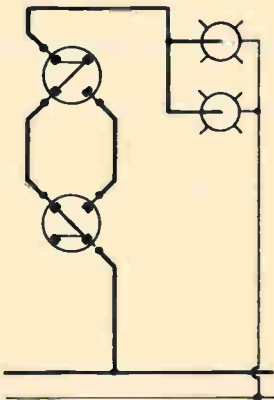


Fig. 16-1

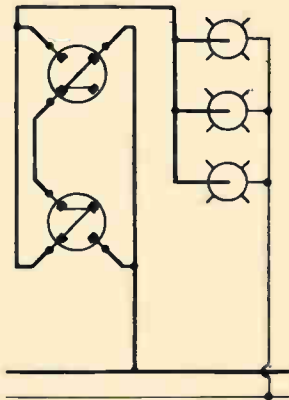


Fig. 16-2

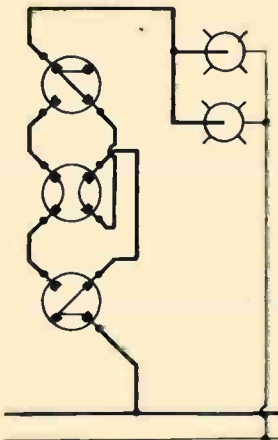


Fig. 16-3

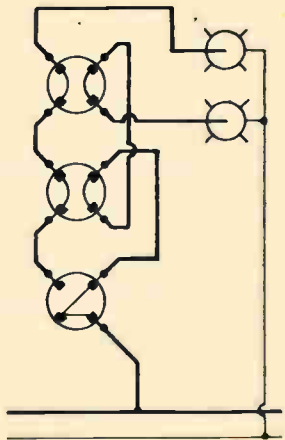


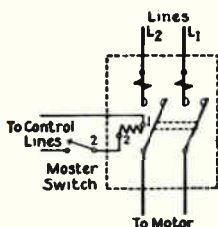
Fig. 16-4

## SWITCHING AND CONTROL

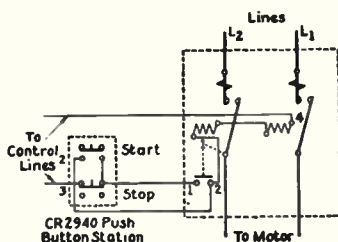
### MAGNETIC CONTACTORS

**Fig. 16-5.** Contactor is controlled by external knife switch in control circuit. Magnet coil is between points 1 and 2 in contactor.

**Fig. 16-6.** Contactor is controlled by push-button station with start and stop buttons. Two magnet coils are in series in the contactor. Holding contacts between 1 and 2 in the contactor close and maintain magnet circuit until stop button is pressed. (General Electric diagrams).



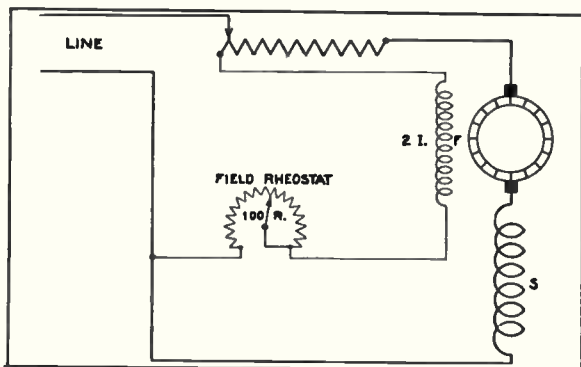
**Fig. 16-5**



**Fig. 16-6**

### DIRECT-CURRENT MOTOR CONTROLS

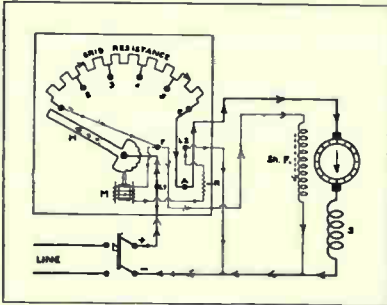
**Fig. 16-7.** Principle of field control and armature control. More field resistance increases the speed above normal running speed. Resistance in series with the armature is used for starting and for speed control. More resistance in series with the armature reduces the speed below normal.



**Fig. 16-7**

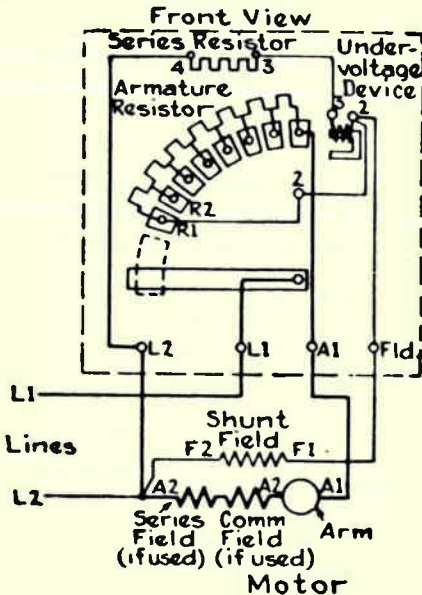
## SWITCHING AND CONTROL

**Fig. 16-8.** Controller for starting and speed variation. Magnet M holds arm in any position from 1 to 6. Full-line arrows show armature current. Broken-line arrows show field current.



**Fig. 16-8**

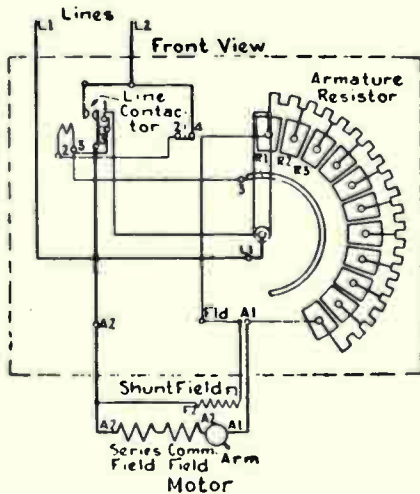
**Fig. 16-9.** Speed regulating rheostat for shunt-wound or compound-wound motors. The undervoltage device releases the arm should voltage drop below a certain value. (General Electric diagram).



**Fig. 16-9**

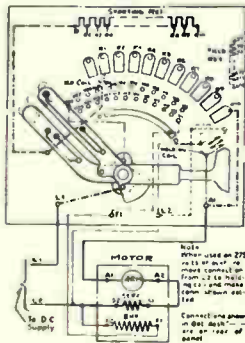
## SWITCHING AND CONTROL

**Fig. 16-10.** Speed regulating rheostat for shunt-wound or compound-wound motors, with line contactor in rheostat. Stop button between points 2 and 4. Magnet coil between 2 and 3. (General Electric diagram).



**Fig. 16-10**

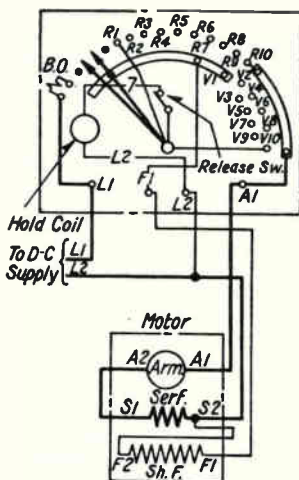
**Fig. 16-11.** Controller for starting and for speed regulation by shunt field control only. Blowout coil, marked B.O. Coil. Series field marked SERF. For shunt-wound motors the series field coil is omitted. (Westinghouse diagram).



**Fig. 16-11**

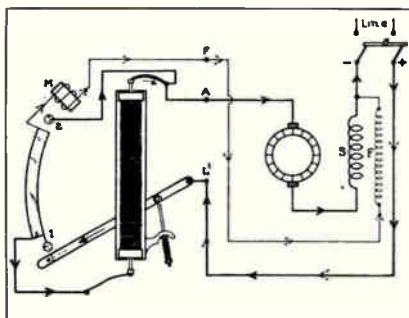
## SWITCHING AND CONTROL

**Fig. 16-12.** Controller providing 50 per cent speed reduction by armature field control and 25 per cent speed increase by shunt field control. For shunt-wound motors the series field is omitted. Blow-out coil marked B.O. Series field marked SERF. (Westinghouse diagram).



**Fig. 16-12**

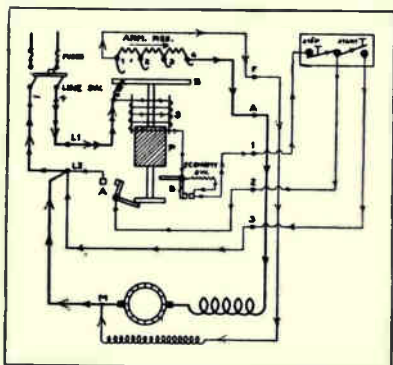
**Fig. 16-13.** Starter with carbon-pile resistor in armature circuit. Solid-line arrows show armature current; broken-line arrows show shunt field current. Field circuit includes holding coil M. When arm reaches contact 2, carbon pile is short-circuited.



**Fig. 16-13**

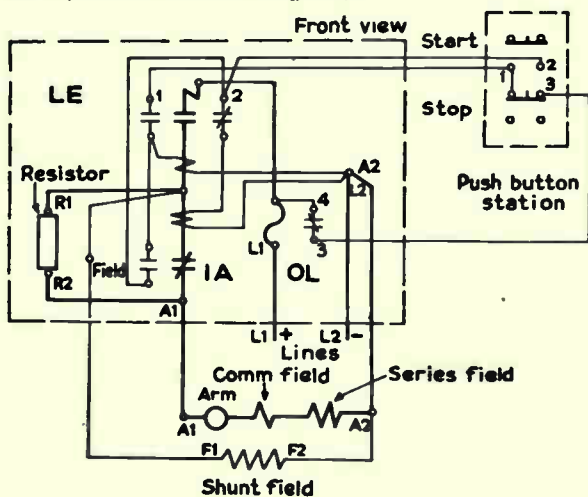
## SWITCHING AND CONTROL

**Fig. 16-14.** Automatic starter of solenoid type. Coil S raises plunger P and contactor bar B to make contact successively at 1, 2, 3 and 4 to gradually cut out resistance. Push button station allows remote control. Contacts A close to complete holding circuit after start button released.



**Fig. 16-14**

**Fig. 16-15.** Magnetic controller with remote control push-button station. Starting resistor is shorted out by contacts IA. Temperature overload relay is marked OL. (General Electric diagram).



**Fig. 16-15**

## SWITCHING AND CONTROL

**Fig. 16-16.** Magnetic controller with push button station for start-stop or for start-jog-stop. Shows line contactors, accelerating contactors and temperature overload relay. (General Electric diagram).

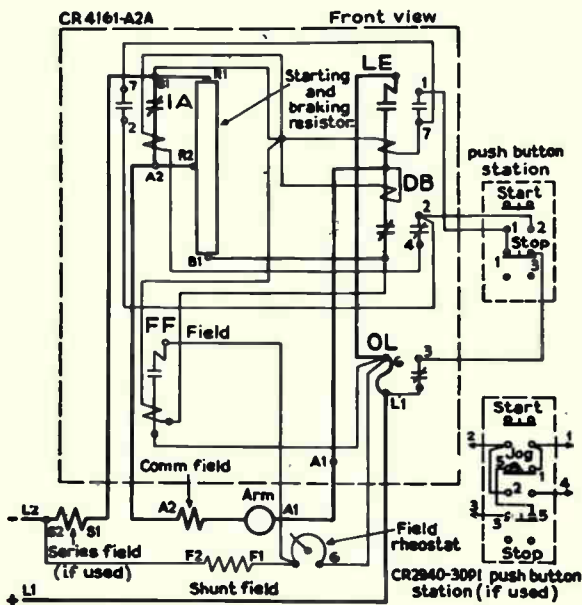


Fig. 16-16

**Fig. 16-17.** Reversing a d-c motor with a double-pole, double-throw knife switch connected between the line and the shunt field.

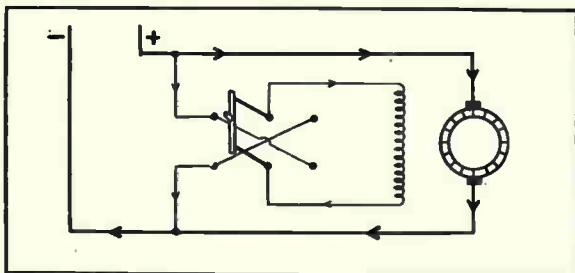
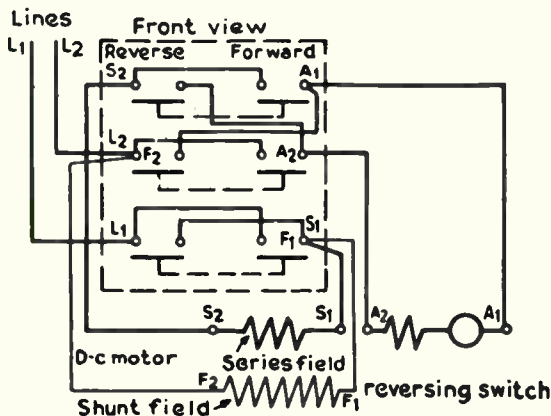


Fig. 16-17



## SWITCHING AND CONTROL

Fig. 16-18. Reversing a d-c motor with a three-pole double-throw switch. The moving contact assembly is operated by a lever. (General Electric diagram).



16-18

Fig. 16-19. Principle of dynamic braking. Full-line arrows show normal direction of armature current with line contacts closed. Broken-line arrows show reversed field current with contacts L1 and L2 open, and D1 and D2 closed.

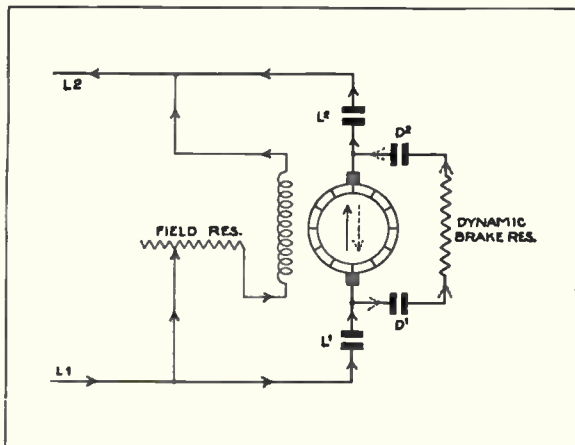
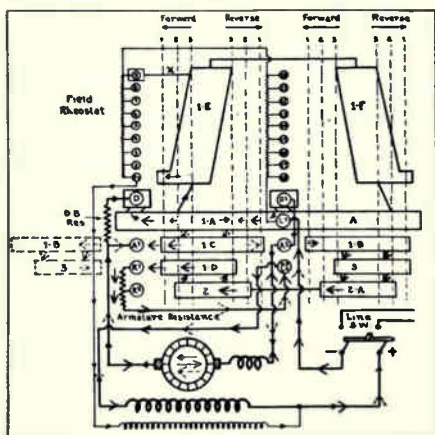


Fig. 16-19

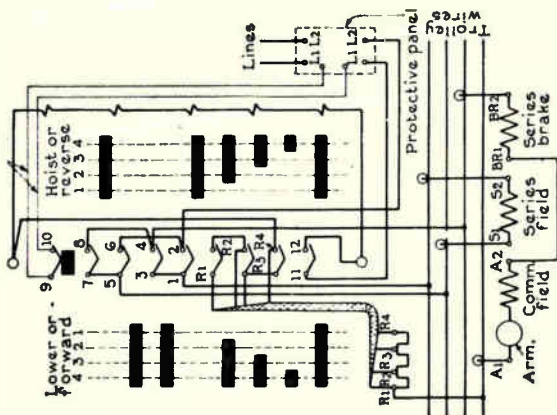
## SWITCHING AND CONTROL

**Fig. 16-20.** Drum controller for starting, reversing, speed control and dynamic braking. Shunt-field resistor taps numbered 1-18. First step closes armature circuit through resistance, also field circuit. Then armature resistance cut out and field resistance cut in to increase speed. Contacts D and D1 are for braking.



**Fig. 16-20**

**Fig. 16-21.** Cam-type drum switch for series-wound motors. Armature points are used for starting only. Field points are for speed control. (General Electric diagram)



**Fig. 16-21**

## SWITCHING AND CONTROL

Fig. 16-22. Cam-type drum switch for shunt-wound or compound-wound motors.

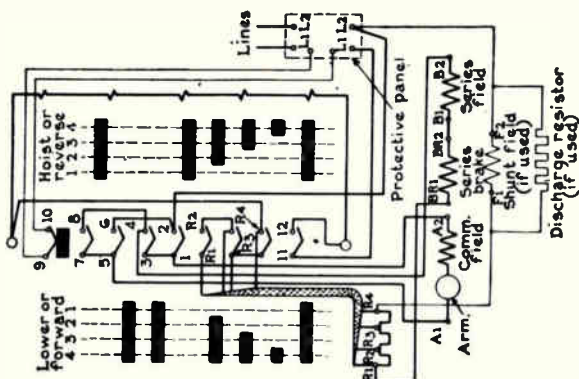


Fig. 16-22

## MOTOR-GENERATOR FOR SPEED CONTROL

The variation in speed obtainable by field control on the ordinary d-c motor will not, in the average case, exceed 4 to 1 due to the sparking difficulties experienced with very weak fields. Although the range may be increased by inserting resistance in series with the armature, this can be done only at the expense of efficiency and speed regulation.

With constant voltage applied to the field, the speed of a d-c motor varies directly with the armature voltage; therefore, such a motor may be steplessly varied from zero to maximum operating speed by increasing the voltage applied to its armature. Fig. 16-23 shows the arrangement of machines and the connections used in the Ward Leonard type of variable voltage control designed to change speed and reverse rotation. The constant speed d-c generator (B) is usually driven by an a-c motor (A) and its voltage is controlled by means of rheostat R. Note that the fields of both generator (B) and driving motor (C) are energized by an auxiliary exciter driven off the generator shaft. Thus the strength of the motor field is held constant, while the generator field may be varied widely by rheostat R.

## SWITCHING AND CONTROL

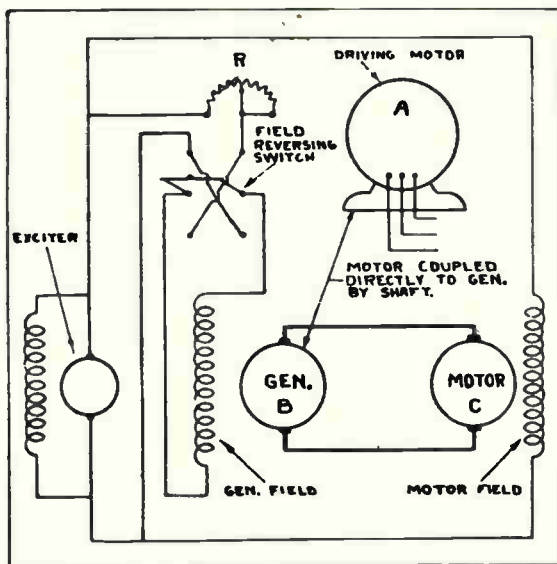


Fig. 16-23

With the set in operation generator (B) is driven at a constant speed by prime mover A. Voltage from B is applied to the d-c motor (C) which is connected to the machine to be driven. By proper manipulation of rheostat R and field reversing switch S the d-c motor may be gradually started, brought up to and held at any speed, or reversed. The advantages of this system lie in the flexibility of the control, the relatively great range over which the speed can be varied, the excellent speed regulation on each setting, and the fact that changing the armature voltage does not diminish the maximum torque which the motor is capable of exerting since the field flux is constant.

As three machines are usually required, this type of speed control finds application only where great variations in speed and unusually smooth control is desired. Steel mill rolls, electric shovels, passenger elevators, large machine tools, large ventilating fans and similar equipments represent the type of machinery to which this method of speed control has been applied.

**Speed Variator.** An a-c motor driving a d-c generator which, in turn, furnishes current for an adjustable speed d-c motor. Generator voltage control is used to

## SWITCHING AND CONTROL

vary the speed. Fig. 16-24 is an elementary diagram. The motor generator is started by means of a push button. The d-c adjustable speed motor is started by another push button and its speed is adjusted by a potentiometer-type generator field rheostat.

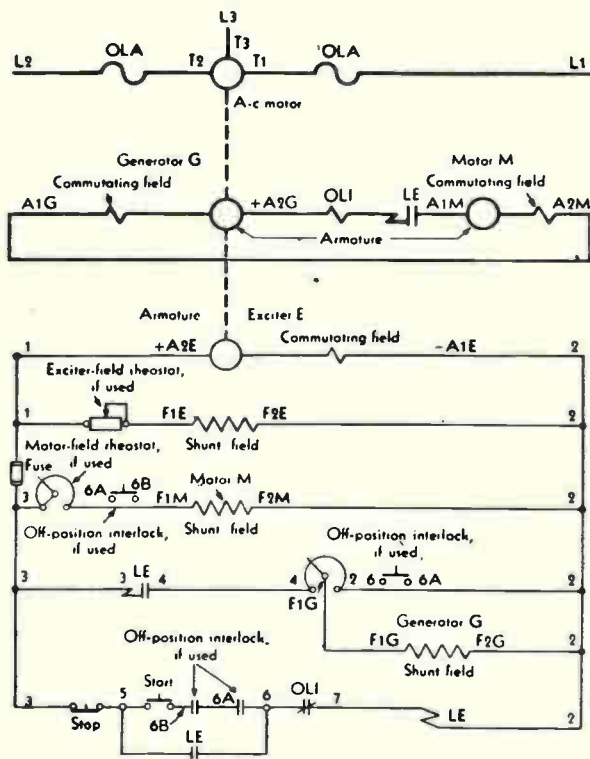


Fig. 16-24

## ALTERNATING-CURRENT MOTOR CONTROLS

Controls for alternating-current motors here are grouped in four classes.

1. Line starters, across-the-line starters, or full-voltage starters, with which the full voltage of the power line is applied when the motor is idle and with which the motor is started with this voltage.

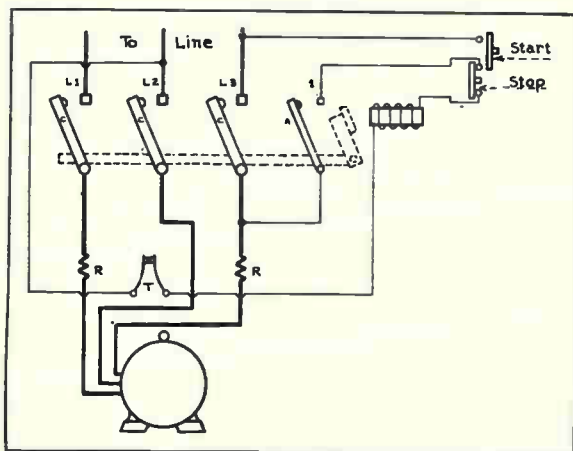
## SWITCHING AND CONTROL

2. Auto starters or compensators, with which a reduced voltage for starting is applied by means of a special form of tapped transformer.
3. Resistance starters for squirrel cage motors, with which a reduced voltage for starting is obtained by means of resistors temporarily inserted in the motor circuit.
4. Resistance controllers for wound rotor motors, with which reduced voltage for starting, and variable voltage for power and speed control, are obtained by means of resistors.

In a separate group are reversing controls and miscellaneous controls.

### LINE STARTERS

**Fig. 16-25.** Principle of magnetic starter, Magnet which operates contactors is energized and de-energized by start-stop push buttons. T—thermal overload contacts. R—thermal overload heater resistors. Unit is for 3-phase 3-wire motors.



**Fig. 16-25**

**Fig. 16-26.** Magnetic starter for 3-phase 3-wire motors. For 2-phase 3-wire circuit both phases of line are connected to L-3, and T-3 is connected to both phases or to common of motor. For 2-phase 4-wire circuit one phase of line is connected to L1 and L3. The other phase of the line has one lead connected to L2, with the other lead of this phase run directly to a motor terminal, not through the starter. One motor phase connects to T1 and T3, with T2 connected to

## SWITCHING AND CONTROL

the other phase lead that comes through the starter. **For single-phase circuit connect line to L1 and L3, run a jumper from L2 to L1, and connect the motor to T1 and T3. (General Electric diagram).**

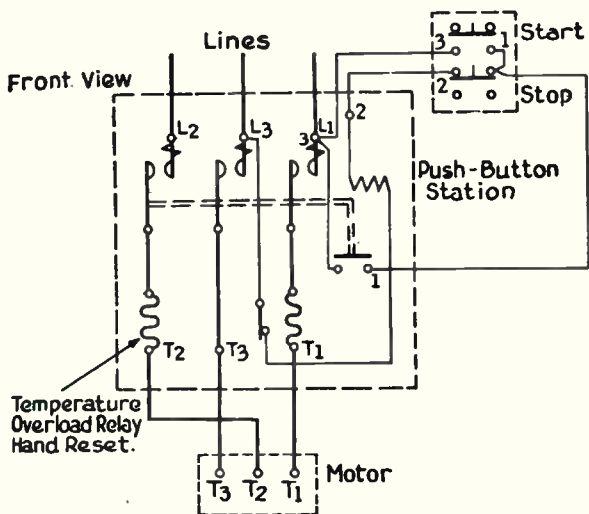


Fig. 16-26

**Fig. 16-27.** Magnetic starter with built-in start-stop buttons. Overload releases marked O.L. If remote start-stop push button station is to be used, remove the lead at terminal 3 and reconnect it at terminal 2. The two start-button terminals then are connected to terminals 1 and 2, while the two stop-button terminals are connected to terminals 3 and 2. (Westinghouse diagram).

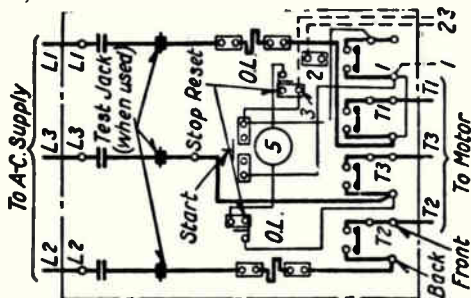
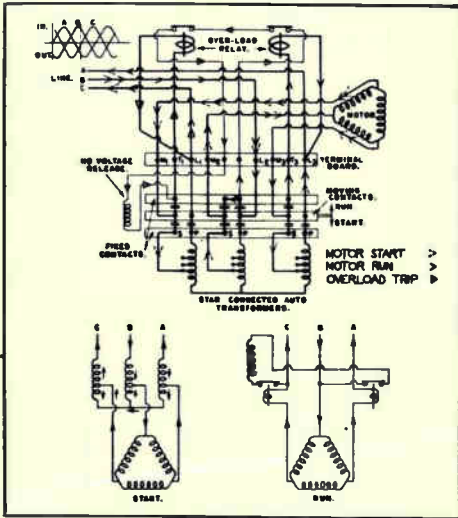


Fig. 16-27

# SWITCHING AND CONTROL

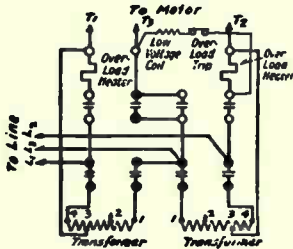
## AUTO-STARTERS OR COMPENSATORS

**Fig. 16-28.** A hand or manually operated starter for 3-phase motors. For starting with reduced voltage from the auto-transformer windings the moving contacts are brought against the lower stationary contacts. For running, the moving contacts are brought against the upper stationary contacts, making a direct connection from line conductors to motor terminals. Overload relays are of plunger magnet type.



**Fig. 16-28**

**Fig. 16-29.** Starter with thermal overload release. Starting contactors are below, connecting to transformers. Running contactors are above.



**Fig. 16-29**



## SWITCHING AND CONTROL

**Fig. 16-30.** Magnetic auto-starter with push-button control and motor-driven timing relay to regulate the duration of the starting period. Starting and running circuits in heavy lines, control circuits in light lines.

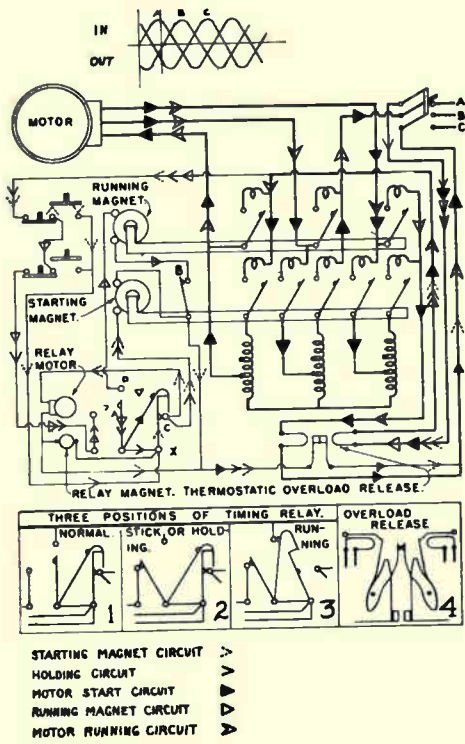


Fig. 16-30

## RESISTANCE STARTERS — SQUIRREL CAGE MOTORS

**Fig. 16-31.** Magnetic starter, push-button operated. Resistors are in series with each phase when starting contactors (upper set) are closed, and are short-circuited when running contactors (lower set) are closed. A definite-time relay of the pendulum type is fastened to the line contactor and starts as soon as this contactor closes, closing the short-circuiting contactors after a definite time interval. (General Electric diagram).

# SWITCHING AND CONTROL

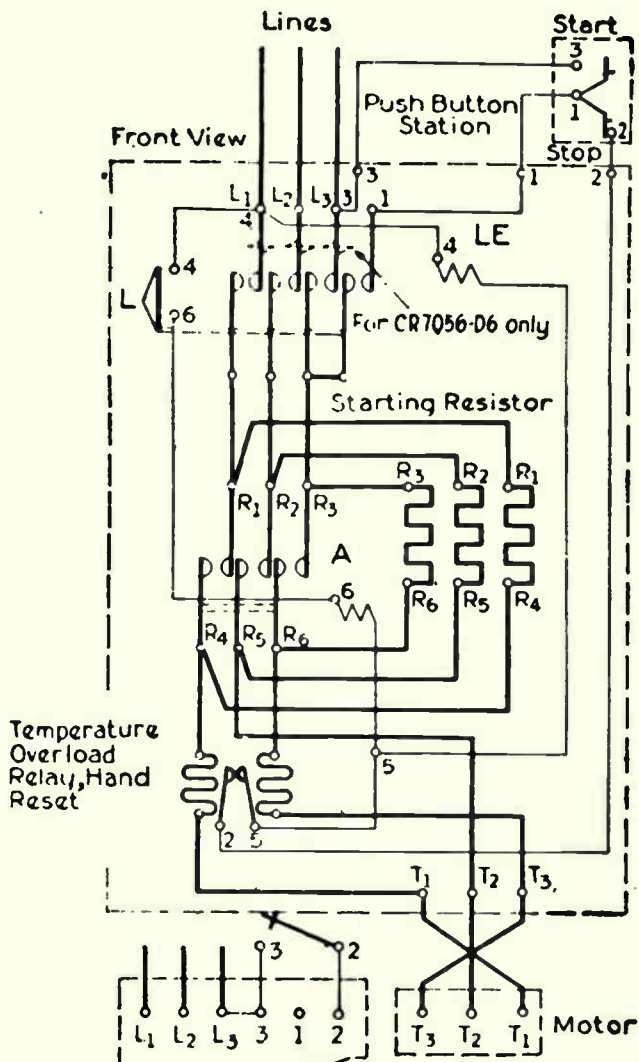


Fig. 16-31

## SWITCHING AND CONTROL

Fig. 16-32. Magnetic starter, push-button operated, with carbon pile resistors. Two push-button stations control motor from two locations. Either start button closes a circuit shown by light arrows through starting magnet SM. Starting contactors close circuits shown by heavy lines. "Stick contacts" are holding lines. Timing relay energizes running magnet to close running contactors after starting interval.

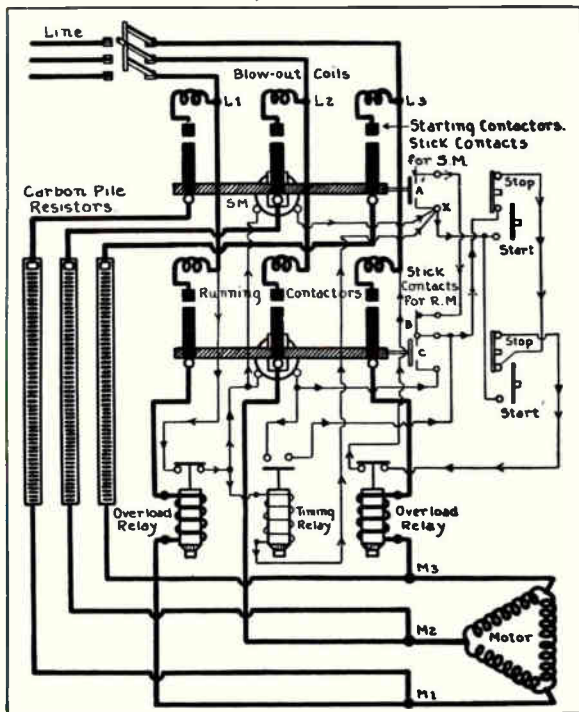


Fig. 16-32

## WOUND ROTOR MOTOR CONTROLS

Fig. 16-33. Principle of inserting resistances in the rotor circuit or secondary circuit of motor. Line switch for stator windings is marked A.

## SWITCHING AND CONTROL

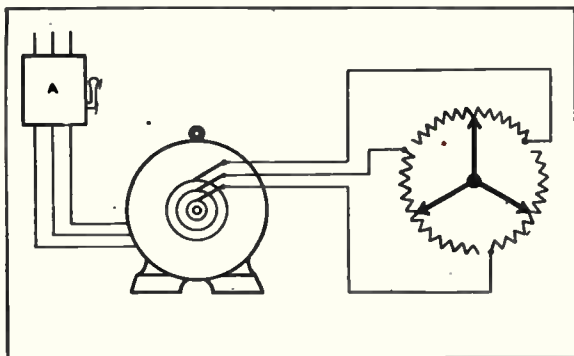


Fig. 16-33

**Fig. 16-34.** Speed-regulating rheostat for wound rotor motor. The CR-7006 switch, interlocked with the rheostat, is a magnetic switch for the primary or stator of the motor. It is actuated by the push-button station similarly to the switch of Fig. 16-26. (General Electric diagram).

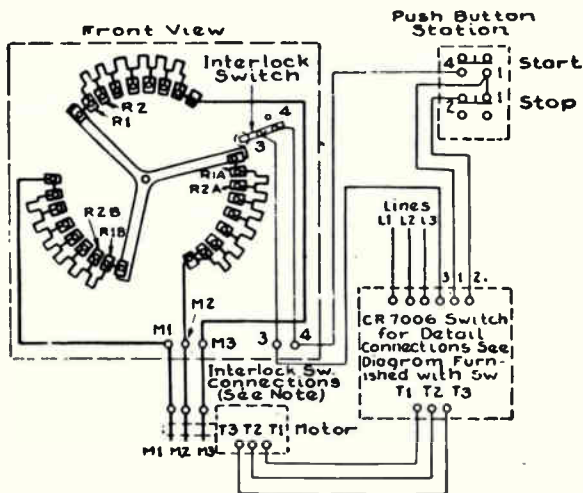
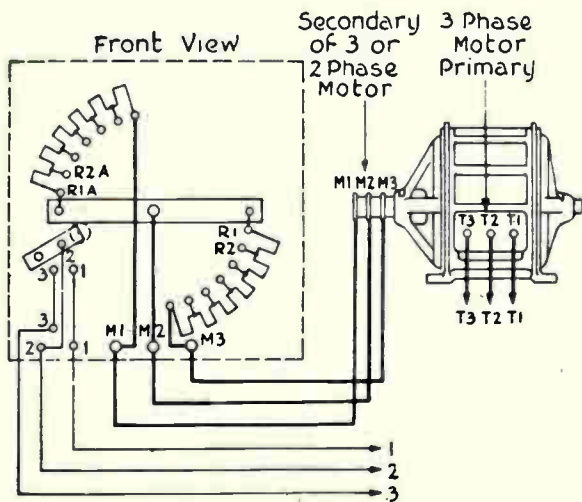


Fig. 16-34

## SWITCHING AND CONTROL

**Fig. 16-35.** Starting rheostat, showing connections to rotor or secondary circuit of motor. A separate switch (not shown) closes the stator or primary circuit for terminals T3, T2 and T1. Terminals 1, 2 and 3 are used only for magnetic primary switch; terminal 1 to holding circuit interlock terminal of switch, terminal 2 to magnet coil in switch, and terminal 3 to line control terminal in switch. (General Electric diagram).



**Fig. 16-35**

**Fig. 16-36.** Magnetic starter, push-button operated. Upper contactors (LE) are for motor primary or stator. Secondary or rotor of motor connects at terminals on contactors 2A to resistor terminals R5, R6 and R7 to place full resistance in circuit for starting. After time delay, contactors 1A close to short-circuit the resistor terminals R2, R3 and R4. After further time delay contactors 2A close to short resistor terminals R5, R6 and R7, thus cutting out all resistance. Overload release with thermal coils is marked O.L. (General Electric diagram)

## SWITCHING AND CONTROL

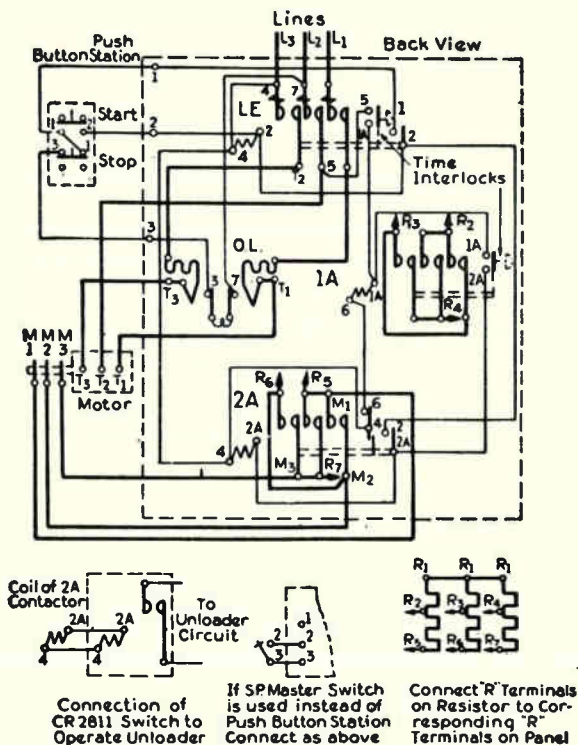


Fig. 16-36

**Fig. 16-37.** Drum controller for wound-rotor motor. Primary motor terminals (stator) are T1, T2 and T3; secondary (rotor) are M1, M2 and M3. One phase of the secondary is open on the first point of the controller. Resistor steps R5-R6, R15-R16 and R25-R26 are for resistance remaining permanently in circuit. If these not supplied, connect M1, M2 and M3 to R5, R15 and R25 as indicated by broken lines. For higher starting torque, or for motors above 80 h.p., connect R1 to R11 at the resistor and finger marked R1 on controller to terminal R3 on resistors. (Westinghouse diagram).

## SWITCHING AND CONTROL

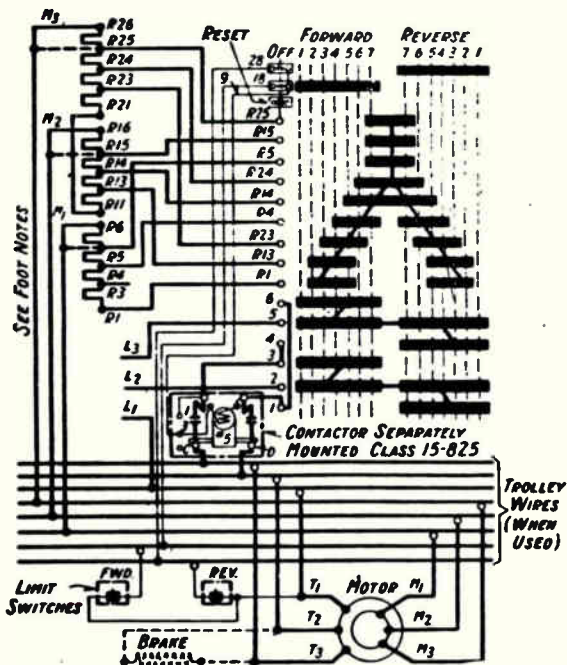


Fig. 16-37

### MISCELLANEOUS CONTROLS

Fig. 16-38. Reversing switch, 3-pole double-throw type, for 3-phase motor. (General Electric diagram)

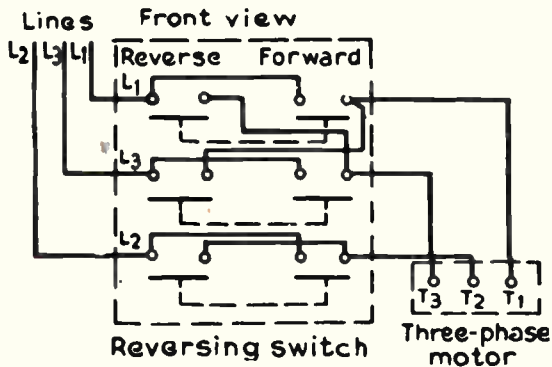
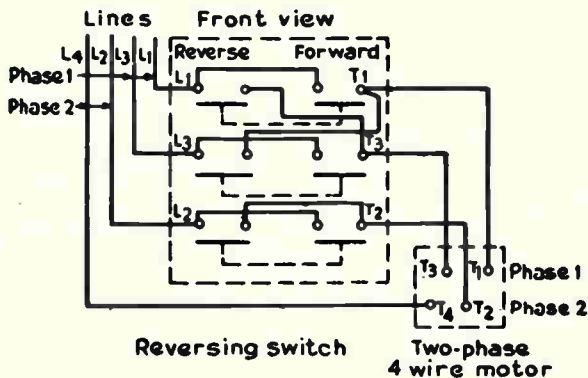


Fig. 16-38

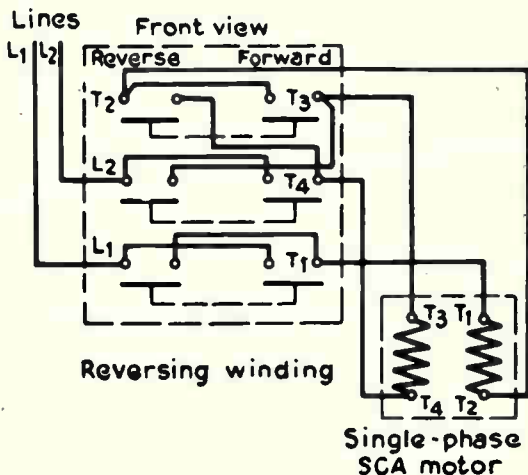
## SWITCHING AND CONTROL

**Fig. 16-39.** Reversing switch for 2-phase 4-wire motor.



**Fig. 16-39**

**Fig. 16-40.** Reversing switch for single-phase motor having a reversible winding.



**Fig. 16-40**

**Fig. 16-41.** Star-delta starting of squirrel cage motor by means of 3-pole double-throw switch. Reduced voltage starting with star connection obtained with switch in upper position. In lower position, windings connected in delta for running.



## SWITCHING AND CONTROL

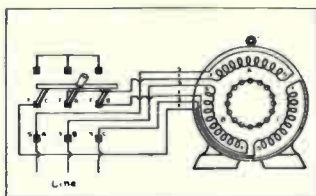


Fig. 16-41

### RESISTOR CLASSIFICATION

N.E.M.A. National Electrical Manufacturers Association  
 Control resistors are classified by numbers in accordance with the percentage of full-load current that flows on the first control point and the portion of an operating period during which current flows in the resistor.

DUTY CYCLE	Time On During Interval	Per Cent Full-load Current on First Point					
		25	30	70	100	150	200 or more
		No.	No.	No.	No.	No.	No.
30 sec. during each 15 mins. 5 sec.	3.3%	101	102	103	104	105	106
80 secs. 10 sec.	6.3%	111	112	113	114	115	116
80 secs. 15 sec.	12.5%	131	132	133	134	135	136
90 secs. 15 sec.	16.7%	141	142	143	144	145	146
60 secs. 15 sec.	25%	151	152	153	154	155	156
45 secs. 15 sec.	33.3%	161	162	163	164	165	166
30 secs.	50%	171	172	173	174	175	176
Continuous	100%	91	92	93	94	95	96

It is assumed that steps of resistance are cut out at equal intervals during the time periods specified, also that the average accelerating current does not exceed 1.25 times the full-load current. The table is based on resistor heating during continued operation for one hour.

## SWITCHING AND CONTROL

### SELECTION AND INSTALLATION

Following are some of the important recommendations of the National Electrical Code relating to motor controllers, starters, switches, and all devices normally used to start and stop a motor, all of which are called controllers.

Alternating-current motor controllers or starters must be capable of interrupting the stalled-rotor current.

**Rating.** The controller shall have a horsepower rating, which shall not be lower than the horsepower rating of the motor, except as follows:

**a. Stationary Motor of  $\frac{1}{8}$  Horsepower or Less.** For a stationary motor rated at  $\frac{1}{8}$  horsepower or less, that is normally left running and is so constructed that it cannot be damaged by overload or failure to start, such as clock motors and the like, the branch-circuit overcurrent device may serve as the controller.

**b. Stationary Motor of 2 Horsepower or Less.** For a stationary motor rated at 2 horsepower or less, and 300 volts or less, the controller may be a general-use switch having an ampere rating at least twice the full-load current rating of the motor.

**c. Portable Motor of  $\frac{1}{4}$  Horsepower or Less.** For a portable motor rated at  $\frac{1}{4}$  horsepower or less, the controller may be an attachment plug and receptacle.

**d. Circuit-Breaker as Controller.** A branch-circuit-type circuit-breaker, rated in amperes only, may be used as a controller. When this circuit-breaker is also used for overcurrent protection, it shall conform to the provisions governing overcurrent protection.

**Need Not Open All Conductors.** Except when it serves as a disconnecting means the controller need not open all conductors to the motor.

**In Grounded Conductors.** One pole of the controller may be placed in a permanently grounded conductor provided the controller is so designed that the pole in the grounded conductor cannot be opened without simultaneously opening all conductors of the circuit.

**In Sight of Motor.** A motor and its driven machinery shall be within sight of the point from which the motor is controlled, unless one of the following conditions is complied with:

**a.** The controller or its disconnecting means is capable of being locked in the open position.

**b.** A manually-operable switch, which will prevent the starting of the motor, is placed within sight of the motor location. This switch may be placed in the remote-control circuit of a remote-control type of switch.

## SWITCHING AND CONTROL

c. Special permission is given by the authority enforcing this code.

**Number of Motors Served by Each Controller.** Each motor shall be provided with an individual controller, except that for motors of 600 volts or less a single controller may serve a group of motors under any one of the following conditions:

a. If a number of motors drive several parts of a single machine or piece of apparatus such as metal and wood-working machines, cranes, hoists, and similar apparatus.

b. If a group of motors is under the protection of one overcurrent device as permitted.

c. If a group of motors is located in a single room within sight of the controller.

**Adjustable-Speed Motors.** Adjustable-speed motors, if controlled by means of field regulation, shall be so equipped and connected that they cannot be started under weakened field unless the motor is designed for such starting.

**Speed Limitation.** Machines of the following types shall be provided with speed limiting devices, unless the inherent characteristics of the machines, the system, or the load and the mechanical connection thereto, are such as to safely limit the speed, or unless the machine is always under the manual control of a qualified operator.

a. Separately-excited direct-current motors.

b. Series motors.

c. Motor-generators and converters which can be driven at excessive speed from the direct-current end, as by a reversal of current or decrease in load.

**Fuseholder Rating.** The rating of a combination fuseholder and switch used as a motor-controller shall be such that the fuseholder will accommodate the size of fuse specified in the tables of running protection for motor wiring.

**Grounding.** Controller cases, except those attached to undergrounded portable equipment and except the lined covers of snap switches, shall be grounded regardless of voltage.

Where grounding is required it is done in accordance with the regular methods for grounding of conduit, armor, boxes and equipment.

**Grounding Through Terminal Housings.** If the wiring to fixed motors is in armored cable or metal raceways, junction boxes to house motor terminals shall be provided. These housings shall be of ample size to properly make connections, they shall be of substantial metal construction, and the armor of the cable or the metal raceways shall be connected to them as required by usual grounding practice.

## SWITCHING AND CONTROL

For a motor of  $\frac{1}{3}$  horsepower or smaller, the junction box required by the preceding paragraph may be separated from the motor not more than 6 feet, provided the leads to the motor are armored cable or armored cord, or are enclosed in flexible or rigid conduit or electrical metallic tubing not smaller than  $\frac{3}{8}$  inch electrical trade size, the armor or raceway being connected both to the motor and to the box.

## Section 17

### ELECTRIC HEATING

Heat is a form of energy which may be produced from electrical energy, chemical energy, and mechanical energy. Heat also may be transformed into other forms of energy.

Quantities of heat energy are measured in a unit called the British thermal unit, which is abbreviated **Btu.**

One Btu of heat energy is the quantity which, added to one pound of water, will raise the temperature of the water one degree Fahrenheit, or which will lower the temperature one degree when removed from one pound of water.

The number of Btu's of heat energy required to raise the temperature of any substance by one degree Fahrenheit is called the **specific heat** of that substance. The specific heat of water is 1.00. Specific heats of other substances are given in the table.

When Btu = Btu's of heat energy  
 lbs. = weight of substance, in pounds  
 SH = specific heat of substance  
 Td = change of temperature or difference between temperatures, degrees F.

$$\text{Btu's} = \text{lbs.} \times \text{SH} \times \text{Td}$$

$$\text{lbs.} = \frac{\text{Btu}}{\text{SH} \times \text{Td}}$$

$$\text{Td} = \frac{\text{Btu}}{\text{lbs.} \times \text{SH}}$$

Equivalent values of heat energy and of electrical and mechanical energy may be found as follows:

Btu's x	0.2928	=	watt-hours
Btu's x	0.0002928	=	kilowatt-hours
Btu's x	777.52	=	foot-pounds
Btu's x	0.0003927	=	horsepower-hours
Watt-hours	x 3.415	=	Btu's
Kilowatt-hours	x 3415.	=	Btu's
Foot-pounds	x 0.001286	=	Btu's
Horsepower-hours	x 2547.	=	Btu's

#### Heating Power

The rate at which heat is produced usually is measured in Btu's per hour, per minute, or per second. Such rates of heat production correspond to rates at which other forms of energy are produced or used. For example, power in watts represents a rate per unit of time at which electrical energy is produced or used

## ELECTRIC HEATING

Heating rates and equivalent electrical and mechanical power rates are as follows:

Btu's per hour	x	777.6	=	foot-lbs. per hour
Btu's per hour	x	12.96	=	foot-lbs. per min.
Btu's per hour	x	0.2160	=	foot-lbs. per sec.
Btu's per hour	x	0.2928	=	watts
Btu's per hour	x	0.0002928	=	kilowatts
Btu's per hour	x	0.0003927	=	horsepower
Btu's per min.	x	46656.	=	foot-lbs. per hour
Btu's per min.	x	777.6	=	foot-lbs. per min.
Btu's per min.	x	12.96	=	foot-lbs. per sec.
Btu's per min.	x	17.57	=	watts
Btu's per min.	x	0.01757	=	kilowatts
Btu's per min.	x	0.02356	=	horsepower
Foot-lbs. per min.	x	0.07716	=	Btu's per hr.
Foot-lbs. per min.	x	0.001286	=	Btu's per min.
Foot-lbs. per sec.	x	4.630	=	Btu's per hr.
Foot-lbs. per sec.	x	0.07717	=	Btu's per min.
Watts	x	3.415	=	Btu's per hr.
Watts	x	0.05692	=	Btu's per min.
Kilowatts	x	3415.	=	Btu's per hr.
Kilowatts	x	56.92	=	Btu's per min.
Horsepower	x	2546.5	=	Btu's per hr.
Horsepower	x	42.44	=	Btu's per min.

The number of Btu's of heat produced in a conductor, such as a resistor used for heating, depends on the watts of power used in the conductor and on the time during which the power is used, as follows:

$$\text{Btu's} = 0.05692 \times \text{watts} \times \text{minutes}$$

$$\text{Btu's} = 3.415 \times \text{watts} \times \text{hours}$$

$$\text{Btu's} = 3415.0 \times \text{kilowatts} \times \text{hours}$$

This heat will raise the temperature of the conductor. As the conductor temperature increases, the conductor will lose heat to its surroundings at an increasing rate. The temperature of the conductor will become stationary when its rate of heat loss becomes equal to its rate of heating due to watts of power expended in the conductor. Thereafter, heat will be transferred from the conductor to its surroundings at the same rate at which heat is put into the conductor by the watts of power used for heating. This is the basic principle of electric heating.

## ELECTRIC HEATING

### SPECIFIC HEATS AND HEATING POWERS

Material	Specific Heat Btu's per Lb.	Watt-Hrs. per Pound per °F.
Air, 70°F., 50% RH.....	0.2434	0.0713
Aluminum .....	.224	.0656
Brass .....	.089	.026
Brick .....	.22	.064
Concrete .....	.156	.0457
Copper .....	.0918	.0259
Gasoline, kerosene .....	.50	.146
Glass, window .....	.200	.0582
Granite .....	.195	.0571
Ice .....	.504	.148
Iron, cast .....	.14	.041
Lead .....	.030	.0088
Nickel .....	.111	.0325
Oil, machine .....	.40	.117
Oil, petroleum .....	.50	.146
Porcelain .....	.22	.064
Tin .....	.054	.016
Water .....	1.000	.2928
Wax, paraffin .....	.69	.202
Zinc .....	.094	.028

### Temperature

Temperature, in degrees, indicates the concentration of heat energy in a substance. For any given material, its temperature indicates the number of Btu's of heat per pound of the material.

The greater the specific heat of a material, the more heat is required to raise its temperature a given number of degrees, and the greater is the gain of heat for any certain rise in temperature.

The temperature of materials having low specific heats undergoes a greater rise with a given quantity of heat than does the temperature of materials having high specific heats.

Water has the highest specific heat. Consequently, for a given change of temperature, water absorbs more heat energy and gives up more heat energy than any other substance. When one pound of water undergoes a temperature drop of one degree, it gives up enough heat to raise the temperature one degree in about 55 cubic feet of air, or in 4.11 pounds of air.

### Water Heating

The cost for heating water electrically is made up of two parts.

## ELECTRIC HEATING

1. Kilowatt-hours required to raise the temperature from the number of degrees at the inlet to the number of degrees desired at the outlet, for the quantity of water to be heated.

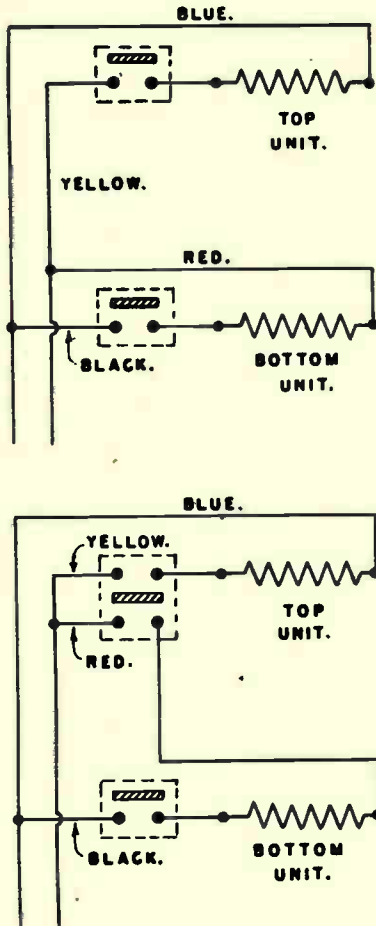


Fig. 17-1. Circuits for water heaters employing two heating units. At left, two single-circuit thermostats; allowing either or both units to operate. At right, one double-circuit thermostat preventing operation of bottom unit when top unit is heating.



## ELECTRIC HEATING

2. A continuous power, in watts or kilowatts, needed to compensate for heat lost from the hot water through walls and insulation of the tank to air and other surrounding materials. This is the "stand-by" loss.

Energy requirements for raising temperature are:

$$\text{lbs. water heated} \times \text{temperature rise, degs.} \times 0.0002928 = \text{kw-hrs.}$$

If the constant is changed to 0.2928 the energy is given in watt-hours instead of in kilowatt-hours.

$$1 \text{ gallon water at } 40^\circ \text{ F.} = 8.345 \text{ lbs.}$$

$$60^\circ \text{ F.} = 8.335 \text{ lbs.}$$

$$70^\circ \text{ F.} = 8.331 \text{ lbs.}$$

$$1 \text{ cu. ft. water at } 40^\circ \text{ F.} = 62.428 \text{ lbs.}$$

$$60^\circ \text{ F.} = 62.348 \text{ lbs.}$$

$$70^\circ \text{ F.} = 62.318 \text{ lbs.}$$

In domestic heaters the water usually is raised to 150° F. as the outlet temperature.

With domestic and small commercial heaters the stand-by losses, in watts per gallon of actual capacity, should not exceed the following:

$$\text{Rated size, 20 gallons} = 3.5 \text{ watts}$$

$$30 \text{ gallons} = 2.9 \text{ watts}$$

$$40 \text{ gallons} = 2.4 \text{ watts}$$

$$50 \text{ or more} = 2.2 \text{ watts}$$

These steady losses must be multiplied by the total number of hours that the heater is operated in order to find the total energy consumption in watt-hours.

An average family, four to five persons, usually is assumed to use from 1,000 to 1,500 gallons per month of hot water.

Example: What is the cost for heating 1,000 gallons per 30-day month, from 40° inlet to 150° outlet, with water kept hot all the time, when energy costs 2 cents per kilowatt-hour? Assume a 30-gallon heater.

$$1,000 \times 8.345 \times (150 - 40^\circ) \times .0002928 = 219.9 \text{ kw-hrs.}$$

$$2.9 \times 24 \text{ (hrs.)} \times 30 \text{ (days)} \div 1,000 = 2.1 \text{ kw-hrs.}$$

$$222.0 \text{ kw-hrs.}$$

$$222 \times 2 \text{ (cents)} = \$6.66$$

### Air Heating or Space Heating

At a temperature of 70° F. and relative humidity of 50% air weighs 0.0741 pound per cubic foot at the average elevation of the larger cities of the United States. This is equivalent to 13.5 cubic feet per pound of air. The specific heat of such air is 0.2434. At the rate of 0.2928 watt-hours per Btu, the energy for heating this air is,

## ELECTRIC HEATING

$$\text{Cu. ft.} \times \frac{\text{temperature}}{\text{rise, degs.}} \times .2434 \times .2928 = \text{watt-hours.}$$

which reduces to,

$$\text{Cu. ft.} \times \text{degs. rise} \times .00528 = \text{watt-hours}$$

This gives the energy requirement only for heating cold air that enters a space, and that escapes after being heated.

Heat is lost from any enclosed warm space to surrounding cooler spaces and objects at a rate usually measured in Btu's per hour. The rate of heat loss depends on many factors, such as temperature differences; thickness, material and construction of enclosures; rate of air circulation, etc. By far the greater proportion of the total energy required for maintaining a temperature is due to these heat losses rather than to the requirement of warming fresh air which is expelled later.

The rate of heat loss, in Btu's per hour, multiplied by 0.0002928 gives the power in kilowatts required for maintaining the desired temperature.

### Process Heating

The total energy for heating batches of materials consists of energy for raising the temperature, plus energy to compensate for heat losses through conduction, convection and radiation from the heating equipment and the material.

$$\text{Pounds heated} \times \frac{\text{Specific heat}}{\text{heat}} \times 0.2928 = \text{watt-hrs. per batch.}$$

$$\text{Losses, Btu's per hour} \times \frac{\text{hours of operation}}{\text{operation}} \times 0.2928 = \text{watt-hrs. added.}$$

The losses in Btu's per hour seldom can be calculated with much accuracy, so are best determined by trial and measurement.

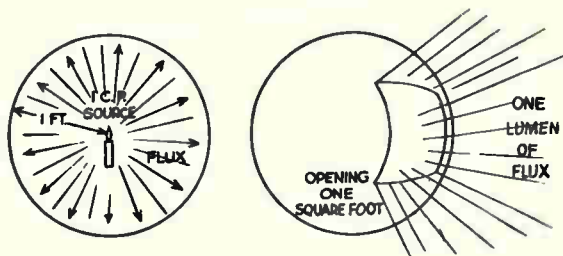
## Section 18 ILLUMINATION

Light is a form of energy which is emitted by and flows away from luminous bodies such as the sun and various kinds of lamps. The flow of light energy is called **luminous flux**. A light source may be thought of as spraying luminous flux more or less uniformly in all directions, much as a water sprinkler sprays water. The total quantity of luminous flux may be measured in lumens, just as total quantity of water flow may be measured in gallons per minute.

A large surface at a given distance from a light source will receive more luminous flux or more lumens than will a smaller surface at the same distance. This is comparable to the larger flow of water received by a large surface at a certain distance from a spray head, and to the smaller flow received on a smaller surface.

The intensity of a light source is measured in candlepower; one candlepower being the intensity of light from a standard candle. A source having an intensity of one candlepower emits a total luminous flux of 12.5664 lumens or about 12.57 lumens. If the one-candlepower source is at the center of a hollow sphere of one-foot radius, as in Fig. 18-1, there will be a total flux of 12.57 lumens on the total interior surface of the sphere. The total interior surface area of a sphere of one-foot radius is 12.57 square feet, so on each square foot there is one lumen of flux.

If one square foot of area is removed from the sphere, one lumen of flux will pass outwardly through this opening. This quantity of luminous flux will spread out thinner and thinner as it moves away from the opening, but no matter how thinly it spreads it still is one lumen of flux.



**Fig. 18-1. A source of one-candlepower delivers one lumen of luminous flux through an opening of one square foot which is one foot from the source.**

## ILLUMINATION

**Foot-candles.** The surface of the sphere in Fig. 18-1 would be uniformly lighted or uniformly illuminated by one lumen of flux falling on each square foot of the surface. The degree of lighting or illumination produced by a flux of one lumen per square foot is called one foot-candle. Supposing that the one lumen of flux falls on surface **A** of Fig. 18-2; this surface being one foot from the light source and having an area of one square foot. The illumination on **A** is one foot-candle.

If **A** of Fig. 18-2 is considered to be an opening rather than a surface, one lumen of flux will pass through this opening. At a distance of two feet from the source the one lumen of flux will spread out to cover area **B**. But area **B** is four times as great as area **A**, so at **B** we have one lumen spread over four square feet, or have one-fourth lumen per square foot. This is an illumination of one-fourth foot-candle at **B**. If the one lumen of flux is allowed to pass through **C**, which is three feet from the source, the one lumen will spread over nine square feet, and the illumination will be one-ninth foot-candle. Illumination in foot-candles is equal to lumens per square foot.

$$\text{Foot-candles} = \frac{\text{lumens}}{\text{area in square feet}}$$

$$\text{Lumens} = \text{foot-candles} \times \text{area in square feet}$$

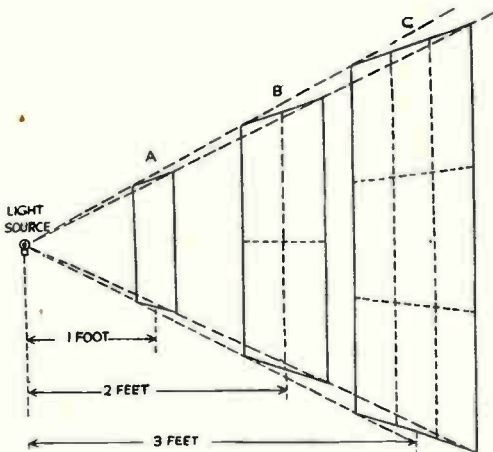


Fig. 18-2. The workings of the inverse square law applied to a flow of light.

## ILLUMINATION

**Law of Inverse Squares.** In Fig. 18-2 the three areas A, B and C are respectively 1, 2 and 3 feet from the light source. Their illuminations are respectively 1,  $\frac{1}{4}$  and  $\frac{1}{9}$  foot-candles.

The squares of the distances 1, 2 and 3 are, respectively 1, 4 and 9. The illuminations on these areas are equal to 1 divided by the square of the distance in each case, or are inversely as the squares of the distances from the source.

The relative illuminations of any two surfaces lighted by the same source, and solely by that one source, are always inversely as the squares of the distances from the source. For example, consider surfaces at 12 inches and 16 inches from a source. The squares of 12 and 16 are 144 and 256. The inverse squares are  $\frac{1}{144}$  and  $\frac{1}{256}$ , or 0.0064 and 0.0039, so the illumination at 12 inches is proportional to 0.0064, and at 15 inches is proportional to 0.0039.

### Illumination Requirements

The degree of illumination at working surfaces and in rooms and buildings used for various activities usually is measured in foot-candles, which are lumens per square foot.

The accompanying table of Illumination Requirements lists minimum and desirable numbers of foot-candles for many locations.

## ILLUMINATION REQUIREMENTS

### Foot-candles

Average practice for good illumination is shown below. Locations not listed may be treated like listed ones of generally similar purpose and use. The lesser of two values indicates the minimum illumination, while the greater one shows the desirable level. Maximums usually may be much higher.

<b>Residential Buildings</b>		<b>Stores</b>	
Living room, kitchen,		Aisles	10-30
dining room.	10-20	Interior, general	30-40
Reading, writing,		Counters, displays	50-100
sewing, etc.	10-30	Show windows	100-200
Bedrooms	5-10	<b>Elevators, passenger</b>	5-15
Stairs, passages	2-10	<b>Factories</b>	
<b>Public Gathering Places</b>		Aisles	4-10
Auditoriums	5-10	Rough work done	10-20
Churches	2-10	Medium or close	
Libraries	20-30	work	30-50
Gymnasiums	10-15	Very close work	50-100
Arenas, indoor	15-30	Inspection and	
Card and game		fine work	60-150
rooms	20-30	Stockrooms	15-30

## ILLUMINATION

Dance halls, night clubs	2-5	Storage, dead stock	2-5
Schools		Garages	10-15
Auditoriums	10-20	General	
Class rooms	15-60	Wherever activities few, or roughest work done	2-6
Manual training, etc.	20-60	Enough light only for pleasing effect	10-15
Offices		General reading and observation for short periods	20-30
Close work required	30-70	Close observation, inspection, etc., for prolonged periods	35-70
No close work	20-30		
Private and general offices	30-60		
Drafting rooms	40-70		
Hotels			
Lobbies	10-15		
Dining rooms	10-20		
Guest rooms	10-15		
Wash rooms, etc.	4-10		

The total number of lumens of flux required to light any surface area to a desired number of foot-candles is equal to the desired number of foot-candles multiplied by the number of square feet of surface.

$$\text{Lumens required} = \frac{\text{foot-candles desired} \times \text{surface area in sq. ft.}}{\text{desired}}$$

The source or sources of light must deliver more total lumens than indicated by this formula because not all of the emitted light reaches the surface to be illuminated.

### Coefficients of Utilization

Fig. 18-3, Coefficients of Utilization, gives the fractions of emitted lumens which may be expected to reach illuminated surfaces from various styles of lamps and shades, in rooms of various proportions of width and height, and with ceilings and walls which are light, medium or dark in shade.

The left-hand column illustrates common styles of reflectors. The second column shows how the light output is distributed in a 90° downward angle, 45° each side of vertical, and in the remaining space, 90° to 180° in a generally upward direction.

The third column lists ratios of room width to room or ceiling height, which are determined by dividing the width in feet by the height in feet. To the right, and on lines with the various ratios, are the fractions of the total flux which are useful for illumination. Note that this table applies directly only to square rooms, and that for oblong rooms it is necessary to follow instructions at the top of the table to determine

## ILLUMINATION

the fraction to be used. Of the six columns of fractions, three columns apply to light ceilings with light, medium or dark walls; two are for medium ceilings with medium or dark walls; and one is for dark ceiling and dark walls. The word **light** as used here refers to light yellows or bright metallic surfaces





















<b>COEFFICIENTS OF UTILIZATION</b>									
This table applies to installations in square rooms having sufficient lighting units symmetrically arranged to produce reasonably uniform illumination. To obtain the coefficient for any rectangular room, find the value for a square room of the narrow dimension and add one-third of the difference between this value and the coefficient for a square room of the long dimension.									
Reflection Factor		Ceiling Walls		Light 8%			Medium 5%		Dark 2%
				Light 50%	Medium 35%	Dark 20%	Medium 35%	Dark 20%	Dark 20%
Reflector Type	Light Output	Ratio = Room Width Ceiling Height							
 Prismatic Glass Bevel Fronted Lamp	 90° to 180°—25%	1	.42	.38	.35	.36	.34	.33	
		1½	.50	.46	.43	.44	.42	.41	
		2	.56	.52	.49	.50	.47	.45	
		3	.63	.59	.55	.56	.53	.51	
		5	.70	.66	.63	.63	.60	.57	
 Light Opal Bevel Fronted Lamp	 90° to 180°—35%	1	.31	.27	.24	.24	.21	.18	
		1½	.37	.33	.30	.30	.27	.24	
		2	.43	.39	.35	.34	.31	.27	
		3	.49	.45	.41	.39	.36	.31	
		5	.56	.52	.48	.45	.42	.36	
 Dense Opal Bevel Fronted Lamp	 90° to 180°—70%	1	.41	.37	.34	.35	.33	.32	
		1½	.49	.45	.42	.43	.41	.39	
		2	.54	.50	.47	.48	.46	.44	
		3	.60	.56	.53	.53	.51	.49	
		5	.67	.63	.59	.59	.57	.54	
 Steel Bowl Porcelain Enamelled	 90° to 180°—5%	1	.38	.36	.34	.35	.33	.33	
		1½	.45	.43	.41	.42	.40	.40	
		2	.49	.47	.45	.46	.44	.44	
		3	.54	.52	.50	.51	.49	.49	
		5	.59	.57	.55	.56	.54	.54	
 Steel Dome Porcelain Enamelled	 90° to 90°—65%	1	.43	.40	.38	.39	.37	.37	
		1½	.52	.49	.47	.48	.46	.46	
		2	.57	.54	.52	.53	.51	.51	
		3	.63	.60	.58	.59	.57	.57	
		5	.69	.66	.64	.65	.63	.63	
 Indirect Mirrored Glass	 90° to 180°—80%	1	.22	.19	.17	.14	.12	.07	
		1½	.27	.24	.22	.17	.15	.09	
		2	.31	.28	.26	.20	.18	.11	
		3	.36	.33	.31	.24	.22	.13	
		5	.42	.39	.37	.28	.26	.16	
 Semi-Indirect Light Opal	 90° to 180°—60%	1	.27	.24	.21	.20	.17	.14	
		1½	.34	.30	.27	.25	.22	.18	
		2	.39	.35	.32	.29	.26	.21	
		3	.45	.41	.38	.34	.31	.25	
		5	.51	.47	.44	.40	.37	.29	
 Semi-Indirect Dense Opal	 90° to 180°—75%	1	.24	.21	.19	.16	.14	.10	
		1½	.30	.27	.24	.20	.18	.13	
		2	.34	.31	.28	.23	.21	.15	
		3	.39	.36	.33	.27	.25	.18	
		5	.45	.42	.39	.32	.30	.21	
 Enclosing Light Opal	 90° to 180°—35%	1	.23	.20	.17	.18	.16	.14	
		1½	.30	.26	.23	.24	.21	.19	
		2	.35	.31	.28	.28	.25	.22	
		3	.41	.37	.34	.33	.30	.26	
		5	.48	.44	.41	.39	.36	.31	
 Semi-Enclosing Opal Bowl	 90° to 180°—70%	1	.32	.28	.26	.27	.25	.23	
		1½	.40	.36	.33	.34	.32	.30	
		2	.45	.41	.38	.39	.37	.35	
		3	.52	.47	.44	.45	.42	.40	
		5	.59	.54	.51	.51	.48	.46	

Fig. 18-3

## ILLUMINATION

or their equivalent in light-reflecting ability; medium is comparable to light pink or its equivalent; and dark is comparable to green or its equivalent in reflection.

To find the total number of lumens actually needed it becomes necessary to divide by the coefficient of utilization, thus,

$$\text{Actual lumens} = \frac{\text{foot-candles} \times \text{area in sq. feet}}{\text{coefficient of utilization}}$$

**Lamps Required.**—Accompanying tables for Incandescent Lamps and for Fluorescent Lamps list the lumens outputs of lamps of various ratings in watts. If lamps of a certain wattage rating are to be used,

### INCANDESCENT LAMPS

#### General Service Types

#### LIGHT OUTPUT AND CURRENT

Rated Watts	Lumens approx.	Amperes at			
		110-v	115-v	120-v	125-v
15	145	.136	.131	.125	.120
25	265	.227	.217	.208	.200
40	480	.364	.348	.333	.320
60	835	.546	.522	.500	.480
75	1150	.682	.652	.625	.600
100	1600	.909	.870	.833	.800
150	2600	1.36	1.31	1.25	1.20
200	3650	1.82	1.74	1.67	1.60
300	5750	2.73	2.61	2.50	2.40
500	9850	4.55	4.35	4.17	4.00
750	15000	6.82	6.52	6.25	6.00
1000	21000	9.09	8.70	8.33	8.00
1500	33000	13.63	13.04	12.50	12.00

Daylight (blue glass) bulbs of a given wattage rating emit 65%, or approximately two-thirds, as much light as lamps with clear glass or inside frosted bulbs. Lumens in the above table may be multiplied by 0.65.

High-voltage lamps (220-260 volts) of a given wattage rating emit about 85% as much light as 110-125 volt types.

### FLUORESCENT LAMPS

#### LIGHT OUTPUT

Rated Watts	Bulb Type	Lumen Output	
		Daylight	White
14	T-12	390	475
15	T-8	525	585
15	T-12	450	525
20	T-12	760	860
30	T-8	1300	1450
40	T-12	1800	2100
100	T-17	3700	4200



## ILLUMINATION

the number of lamps required will be equal to the actual total lumens divided by the number of lumens delivered by lamps of that size.

$$\text{Lamps, number required} = \frac{\text{actual total lumens}}{\text{lumens per lamp}}$$

If the number of lamps is known in advance, the size of the lamps, in lumen output, is equal to the actual total lumens divided by the number of lamps

$$\text{Lumens per lamp} = \frac{\text{actual total lumens}}{\text{number of lamps}}$$

### Example

A library with floor size of 30 by 50 feet, and with a 10-foot ceiling, is to be lighted with 200-watt incandescent lamps in semi-indirect fixtures with opal bowls. The ceiling is light and the walls dark. How many lamps will be needed?

From the table of illumination requirements a library should have 20 to 30 foot-candles. We shall figure on 30 to allow for drop-off in light as lamps age, and for dust collecting in fixture bowls.

Using table of coefficients of utilization:

$$30/10 = \text{ratio of 3. Coefficient} = .38$$

$$50/10 = \text{ratio of 5. Coefficient} = .44$$

$$.44 - .38 = .06 \quad \frac{1}{3} \text{ of } 0.6 = .02$$

$$.38 + .02 = .40, \text{ the coefficient for this room.}$$

$$\text{Actual lumens} = \frac{30 \text{ (f-c)} \times 30 \times 50 \text{ (feet)}}{.40} = 112500$$

From table of incandescent lamps; 200-watt size gives 3650 lumens.

$$\text{Lamps required} = \frac{112500}{3650} = 30.8. \text{ Use 31 lamps.}$$

## FLUORESCENT LAMPS

The fluorescent lamp, tubular in shape, contains at each end an electrode in the form of a small coil of wire (see Fig. 18-4). These electrodes are coated with a material which has the property of freely emitting electrons when heated. Electrons are necessary to carry the arc current which passes through vaporized mercury. Since mercury is a liquid at normal temperatures, a slight amount of argon gas is used to facilitate starting. A base is sealed to each end of the lamp.

Fluorescent powders, called **phosphors**, are coated on the inside of the bulb by a liquid washing process followed by a heat treatment.

## ILLUMINATION

All of the phosphors are white when not exposed to ultraviolet radiations. Thus, the unlighted appearance of most fluorescent lamps is identical. Exceptions are the gold and red lamps in which it is necessary to coat the bulb with an appropriate pigment.

It is characteristic of all arc lamps that some method must be provided for limiting the current drawn by the discharge. Without a limiting device, the current would rise to a value that would destroy the lamp. This requirement for fluorescent lamps can best be met by a device or auxiliary not incorporated in the lamp itself. The necessity for an auxiliary permits using that device to gain definite advantages in lamp design and performance.

Auxiliary equipment for the present design of fluorescent lamps serves 3 important functions. In order, the equipment:

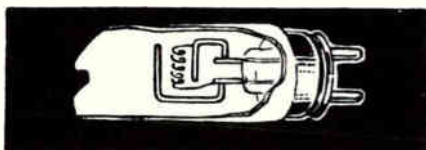


Fig. 18-4

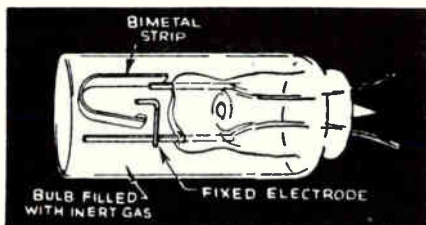


Fig. 18-5

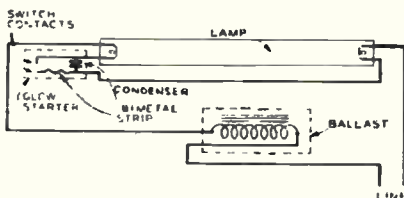


Fig. 18-6

## ILLUMINATION

- (1) Preheats the electrodes to make available a large supply of free electrons.
- (2) Provides a surge of relatively high potential to start the arc between the electrodes.
- (3) Prevents the arc current from increasing beyond the limit set for each size of lamp.

For 15- and 20-watt lamps, an open-circuit voltage of at least 100 is required; for 30- and 40-watt lamps, the required open-circuit voltage is about 190. At these voltages or higher levels, ordinary reactances (chokes) or resistances will provide the necessary current limitations. For distribution systems in the 110-125 volt range, a transformer must be part of the auxiliary equipment for 30- and 40-watt lamps. Usually this transformer and the required reactance for current limitation are combined in one unit.

Lamps are automatically started by a starter switch enclosed in a neon-filled glass bulb protected by a metallic or fibre cover.

The switch is enclosed in a small glass bulb and consists of 2 electrodes, one of which is made from a bimetallic strip (Fig. 18-5). These are separated under normal conditions and form part of a series circuit through the lamp electrodes and the reactance. When voltage is applied, no current flows except as a result of the glow discharge between 2 electrodes of the switch. A heating results which, by the expansion of the bimetallic element, causes the electrodes to touch. This short-circuiting of the switch, which takes 1 or 2 seconds to be completed, allows a substantial flow of current to preheat the lamp electrodes. There is enough residual heat in the switch to keep it closed for a short period of time for the preheating. With the opening of the switch, the resultant high-voltage surge starts normal lamp operation. If the lamp arc fails to strike, the cycle is repeated.

The switch does not again glow (if the lamp arc is established) since it is so designed that the remaining available electrical potential is insufficient to cause a breakdown between its electrodes. Thus, it consumes no power and if the lamp is turned out, is available for immediate restarting.

In the latest application of the glow switch the switch and condenser are combined in a Fluorescent Lamp Starter. (See Fig. 18-6). The Starter consists of a glow switch and condenser which are enclosed in a small aluminum container with contacts which may be easily inserted in a bayonet-type adapter socket. This socket may be an integral part of the standard lampholder attached to it by a single screw or merely connected to it electrically. Usually the Starter is so placed that it projects through a hole

## ILLUMINATION

in the lamp reflector and becomes as readily replaceable as the lamp itself. The switch provides the lamp electrode preheating and the starting surge; **the condenser suppresses radio interference.** Since the switch is designed to operate between critical voltage limits, the proper starter must be used for each particular lamp to insure satisfactory starting.

The Ballast is a current-limiting device consisting of a reactor or high reactance transformer enclosed in a metal case.

In general, best lamp performance is obtained when line voltage is kept within the rating limits of the auxiliaries. At either under- or overvoltage conditions, the lamp electrodes do not operate at their greatest effectiveness. At lower voltage, electrodes do not reach high temperatures and they are overworked, while overvoltage causes excessive heating that quickens the loss of emissive material. The result in either case is shortened life accompanied or preceded by excessive blackening. Also, high voltage may overheat the auxiliary while under-voltage may cause uncertain starting.

Auxiliaries must be designed specifically for particular frequencies. Equipment designed for 60 cycles should not be used on 50 cycles, nor is the reverse satisfactory. Operation at frequencies less than 50 cycles, seriously increases the problem of stroboscopic effect and, therefore, standard equipment is not available.

The reactor or high-reactance transformer used with fluorescent lamps produces a definite "out-of-phase" relation between voltage and current which results in a power factor of about 55%.

Since low power factor in fluorescent lamps is primarily a result of the reactance, it may be raised by the addition of a condenser to the circuit. The exact rating of the condenser depends on the degree of correction desired and the size and number of lamps to be balanced.

The single lamp ballasts with power factor correction and the 2-lamp auxiliary already described are particularly effective since power factor correction is an integral part of each unit. Wiring connections to be made are at a minimum, while, at the same time, the over-all efficiency of the light source is increased through the reduction of electrical losses.

The fluorescent lamp is basically an A.C. lamp and while adaptable to D.C. cannot be expected to give equal performance. All published ratings are based on A.C. operation.

It is characteristic of all A.C. light sources that there is some variation in light output dependent on

## ILLUMINATION

the cyclic variations of the current. With incandescent lamps, this is negligible since the filament retains enough heat to compensate for the variation of the current throughout each cycle. With fluorescent lamps, the carry-over of light is dependent wholly on the phosphorescent qualities of the coating. This characteristic of the phosphors varies considerably. The phosphor used in the green lamp has the brightest carry-over, while the phosphor for the blue has the least.

Since very frequent starting will affect the life adversely, fluorescent lamps are not recommended for services of a type similar to the flashing of lamps in signs.

Noticeable blackening prior to 750 hours is generally caused by improper operating conditions (voltage, bulb temperature, choke characteristics, starter defects, etc.). Trouble from such conditions can be found by investigation and must be corrected for best service.

### MERCURY VAPOR LAMPS

The mercury vapor lamp is made for use on D.C. or A.C. circuits of 95 to 125 volts, but the lamps for A.C. operation are constructed differently than those for D.C. circuits, and should therefore not be connected on D.C. circuits.

These lamps consist of the mercury tube, an auto transformer, an inductance coil, a mercury switch (shifter switch), three resistors, the frame and cover. See Fig. 18-7.

The auto transformer serves to step up the voltage to about 235 volts across the tube anodes. About 135 volts is applied to the tube between either anode and cathode. This transformer is tapped for adjustment for various line voltages as the lamp will not operate properly if the voltage is too low or too high.

The induction coil supplies a momentary high voltage impulse of about 4,000 volts to the starting band and cathode to excite the surface of the pool of mercury to start the lamp. This action is produced by the application of this high voltage to a sort of condenser formed by the pool of mercury inside the lower end of the tube and the metal band around the outside of the glass tube at this point.

The high voltage impulse from the inductance coil is produced by the mercury shifter switch quickly breaking the circuit through the coil. This switch is magnetically operated by the flux of the core of the inductance coil when the lamp is turned on. After the lamp starts this switch is held open by the magnetism produced by the continual current flow through the

## ILLUMINATION

coil. This inductance coil also serves to smooth out the current flow and maintain voltage on the tube during zero periods of each alternation.

The ballast resistors, R1 and R2, in series with the anodes, increase their resistance as their temperature is increased by an excess voltage and current, thereby protecting the lamp tube from moderate over-voltages.

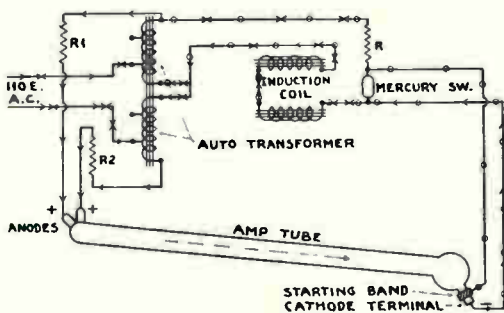


Fig. 18-7

## SODIUM VAPOR LAMPS

The sodium vapor lamp (Fig. 18-8) produces a mono-chromatic (one color) light in the yellow band, which permits unusually clear vision of objects along highways at night, and of metal objects in shops. The efficiency of these lamps is about 45 lumens per watt or about 3 times that of ordinary mazda lamps. This type of lamp is unsuited for ordinary indoor general illumination because the yellow light makes people and objects appear gray.

In its construction sodium vapor is used in an evacuated tube, and when an electric current at low voltage is passed through this gas it causes it to glow with a brilliant golden light. The lamps operate on from 2 to 28 volts with a current of 5 to 10 amperes.

For alternating current service they use a pair of anodes (positive electrodes) and a pair of cathodes (negative electrodes) located in opposite ends of the gas-filled tube as shown in the diagram. The cathodes or filaments are heated to throw off electrons needed to establish the arc through the gas. A small amount of neon gas is included with the sodium vapor to make it easier to start the arc. This causes the lamp to give off a reddish light during the first few minutes of operation. The sodium vapor lamp also has an outer glass envelope or encloser to retain the heat required to produce the maximum lighting and efficiency.

## ILLUMINATION

A special transformer as shown in the diagram is needed to supply the proper voltages for the filaments and arc electrodes. The filament circuits can be traced

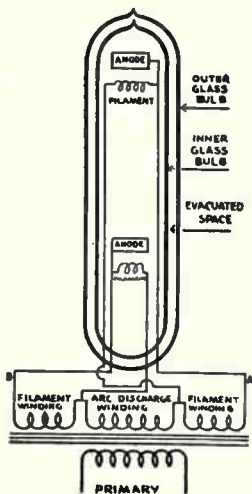


Fig. 18-8

separately from the arc circuit. On one alternation the arc current flows from terminal A to top anode, through gas to lower cathode or filament and back to terminal B. On the opposite alternation, arc current flows from terminal B to lower anode, through gas to upper cathode and back to terminal A.

### Installation of Lamps

Following are extracts from recommendations of the National Electrical Code relating to lampholders and to the computation of feeder loads for illumination service. A lampholder (called by many a socket) is a screw shell device for receiving the screw base of an incandescent lamp or other part with a similar screw base, and for making electrical connections to the part thus held.

Lampholders shall be classed according to diameters of lamp bases, as Candelabra, Intermediate, Medium, Admedium, and Mogul base; having respectively  $\frac{1}{2}$  inch,  $\frac{21}{32}$  inch, 1 inch,  $\frac{11}{16}$  inch, and  $1\frac{1}{2}$  inch nominal sizes, with ratings, as specified in the following table:

# ILLUMINATION

Class	Nominal Diam.	RATINGS— SWITCHED			RATINGS— UNSWITCHED		
		Watts	Volts	Max. Amp. at any Voltage	Watts	Volts	Max. Amp. at any Voltage
Candelabra . . . . .	½ in.	75	125	¾	75	125	1
Intermediate . . . . .	21/32 in.	75	125	¾	75	250	1
Medium . . . . .	1 in.	250	250	2½	660	250	6
		660(a)	250	6	660	600	
Admedium . . . . .	1 1/16 in.				660	250	
Mogul . . . . .	1½ in.	750	250		1500	250	
		1500	250		1500	600	

(a) This rating may be given only to lampholders having a switch mechanism which produces both a quick "make" and a quick "break" action.

Miniature lampholders and receptacles having screw-shells smaller than the Candelabra size may be used for decorative lighting systems, Christmas-tree Lighting Outfits and similar purposes.

Lampholders in clothes closets shall be installed on the ceiling or on the wall above the door. Drop cords shall not be installed in clothes closets.

If portable lamps, supplied through flexible cords, can come in contact with inflammable material, the lampholder shall be equipped with a handle and substantial guard. The guard shall be attached to the lampholder or to the handle. Similar equipment shall be used to protect portable lamps from breakage.

If used on unidentified 2-wire circuits tapped from the ungrounded conductors of multi-wire circuits, the switching devices of lampholders of the switched type shall disconnect both conductors of the circuit.

Receptacles of the screw-shell type shall be installed only for use as lampholders.

If a lampholder is attached to a flexible cord, the inlet shall be equipped with an insulating bushing which, if threaded, shall not be smaller than nominal 3/8 inch pipe size. The edges of the bushing shall be rounded and all inside fins removed in order to provide a smooth bearing surface for the conductors.

Bushings having holes 9/32 inch in diameter are suitable for use with plain pendent cord and holes 13/32 inch in diameter with reinforced cord.

**Computation of Feeder Loads.** The computed load of a feeder shall be the sum of the computed loads as determined for branch circuits in accordance with the rules for such circuits, subject to the following provisions:

The feeder load for general illumination in the following occupancies shall be computed according to the wattage per square foot specified:

Occupancy	Watts per Square Foot
Industrial Commercial Loft Buildings.....	1
Garages, Commercial .....	.5
Storage Warehouses .....	.25



## ILLUMINATION

**Demand Factors.** Demand factors specified in the following table may be applied to the computed loads for general illumination as determined by the preceding paragraph, and minimum watts per square foot for various occupancies.

Type of Occupancy	Wattage based on Area Served	Demand Factor in per cent
Single-family dwellings*	2,500 or less	100
	Excess over first 2,500	30
Multi-family dwellings (other than hotels) and apartment houses with provisions for cooking by tenants*	3,000 or less	100
	Excess over first 3,000 but not more than 120,000	35
	Excess over 120,000	25
Hospitals†	50,000 or less	40
	Excess over first 50,000	20
Hotels*†	20,000 or less	50
	Excess over first 20,000 but not more than 100,000	40
	Excess over 100,000	30
Office buildings	20,000 or less	100
	Excess over first 20,000	70
Schools	15,000 or less	100
	Excess over first 15,000	50
Storage warehouses	12,500 or less	100
	Excess over first 12,500	50

\*The small appliance load may be included with the lighting load and subject to the demand factors specified. If the load in single-family dwellings, individual apartments of multi-family dwellings, and in hotel suites having serving pantries, is sub-divided through two or more feeders, the computed load for each shall include not less than 1,500 watts for small appliances.

†For sub-feeders to areas where entire lighting is likely to be used at one time, as in ballrooms, dining rooms, operating rooms, etc., a demand factor of 100 per cent shall be used.

The unit values and the demand factors of the table, are based on minimum load conditions and may not provide sufficient feeder capacity for the installation contemplated. If at any time it is found that feeder conductors will be, or are, overloaded, they shall be increased.

In view of the trend toward higher intensity lighting systems and indirect lighting, and increased loads due to more general use of fixed and portable appliances, each installation should be considered as to the load likely to be imposed, and feeder capacity increased to permit of efficient and economical operation without expensive alterations and replacements in the system.

## ILLUMINATION

For general illumination, in the occupancies shown in the following table, a load of not less than the "watts per square foot" as specified for each occupancy shall be included for each square foot of floor area.

Apartments and multi-family dwellings	2 watts
Armories and auditoriums	1
Banks	2
Churches	1
Clubs	2
Dwellings, single-family	2
Hospitals	2
Hotels	2
Office buildings	2
Restaurants	2
Schools	3
Stores	3

In any of the above listed occupancies, except single-family dwellings and individual apartments of multi-family dwellings:

Assembly halls and auditoriums	1 watt
Hallways, corridors, and closets	$\frac{1}{2}$
Storage spaces	$\frac{1}{2}$

## Section 19

# INDUSTRIAL ELECTRONICS

Electronics is the science, or art, which deals with the flow of electricity through vacuums and gases confined within tubes or tanks. Industrial electronics is the branch of electronics dealing with the application of electronic tubes in manufacturing, assembling, processing and similar industrial or commercial work.

Separate elements used in electronic tubes may be represented by symbols shown in Fig. 19-1. These symbols are combined to represent complete tubes as in Fig. 19-2.

Envelopes are the glass or metallic enclosures which confine the vacuum or the gas through which electricity flows within the tube. Gas is indicated by a dot placed anywhere within the envelope.

Cathodes are the tube elements from which electron flow enters the vacuum or gas spaces inside the tube. Cathodes may be directly heated by electricity flowing through them (then often called filaments), or may be indirectly heated by a separate element through which electricity flows. Tubes with heated cathodes are called **thermionic tubes**. Some tubes have unheated (cold) cathodes, among them being phototubes and pool tubes.

Anodes are the tube elements through which electron flow leaves the vacuum or gas within the tube. Anodes may be called plates. With reference to the external sources the anode is positive and the cathode negative. Considering the conventional direction of current flow, current enters the tube through the anode and leaves through the cathode.

Control electrodes, or grids, regulate the timing and rate of flow of electricity through the tube. The symbol shows a control electrode used for control by means of potential or voltage changes. Control may be effected also by magnetic fields passed through the tube, by the ignitor electrode in ignitron tubes, and in other ways.

### Types of Tubes

**Kenotron.** A vacuum-type thermionic tube in which there are no electrodes for control of electric flow. Kenotrons are rectifiers for changing alternating to direct current. They operate with small currents, usually not over one ampere, but may operate at high voltages.

**Phanotron.** A gas-filled thermionic tube with no control for electric flow. Phanotrons are rectifiers, usually handling rather large currents at lower voltages than in the kenotron, say up to 20,000 volts.



## INDUSTRIAL ELECTRONICS

**Pliotron.** A vacuum-type thermionic tube in which there are one or more control electrodes or grids. Triodes are pliotrons with a single control grid. Tetrodes are pliotrons with two control grids, one being a screen grid or shield grid. Pentodes are pliotrons with three control grids; one for regulating the rate of flow, one a screen grid, and one a suppressor grid. Pliotrons are used for amplification or strengthening of voltages and currents, also as oscillators for production of high-frequency voltages and currents.

**Thyratron.** A gas-filled thermionic tube with one or two control grids. A triode thyratron contains one control grid which controls the instant at which electric flow starts. The flow is stopped by reduction of anode potential, usually to zero. The tetrode thyratron or shield-grid thyratron contains, in addition, a screen grid. Thyratrons are the tubes most widely used in industrial electronics for control purposes of all kinds; handling moderate currents and voltages up to about 20,000. They are used also for rectifiers with which the rate of current flow may be controlled. These tubes are found in welding controls, automatic timing, motor and generator controls, line voltage regulation, and many other applications.

**Ignitron.** A gas-filled tube (or tank) having a mercury pool cathode. An ignitor electrode controls the instant at which electric flow starts. The flow is stopped by reduction of anode potential. Ignitrons are used for control, and controlled rectification, of large amounts of power such as required in electrochemical and electrometallurgical processes; production of metals and chemicals, mining, transportation, etc.

**Phototube.** A vacuum or gas-filled tube with an anode, and with a cold cathode which emits electrons when reached by visible light or by other forms of radiation which are in the infra-red or ultra-violet regions and are not visible. Vacuum phototubes may be operated at high voltages (usually up to 500). Electron flow or current is proportional to intensity of radiation, but the change of flow for a given change of radiation is less than in gas-filled types. Gas-filled types may be operated at voltages no higher than 90. Their response to radiation is linear or strictly proportional only with rigidly controlled conditions, but they produce greater changes of current for given changes of radiation than do vacuum types. Phototubes are used for all types of controls which are to respond to changes of light or radiation.

**Glow Tube.** A cold-cathode gas-filled tube with no control for electric flow. It is used for indicating lights, for current-limiting, and for rectifying and regulation at low voltages with small currents.

## INDUSTRIAL ELECTRONICS

**Grid-glow Tube.** A cold-cathode gas-filled tube with one or more control electrodes which regulate the instant of starting of electric flow. These tubes are used somewhat similarly to thyratrons, but are limited to handling small amounts of power such as may be used in safety controls and similar applications.

**X-ray Tube.** A high-vacuum thermionic tube having cathode and anode, but no control electrodes. These tubes produce X-ray radiation used for inspection of industrial products.

**Pool Tube.** A gas-filled tube with a mercury pool cathode, one or more anodes, but no control electrode. These tubes are used for rectifying very large currents, supplying d-c power for purposes similar to those served by ignitrons.

**Grid-pool Tube.** A gas-filled tube with mercury pool cathode, one or more anodes, and a control electrode which regulates the instant at which electric flow starts in the tube. These tubes are used similarly to ignitrons.

The term gas-filled refers to tubes which contain either inert gases, such as argon, neon and helium, or to tubes which contain the vapor of mercury produced either from a pool cathode or from a few drops of liquid mercury within the tube. Inert gases and mercury vapor sometimes are used together.

It should be kept in mind that all electronic tubes are rectifiers, in the sense that they permit electron flow only from cathode to anode, or conventional current flow only from anode to cathode, and never in the reverse direction so long as the tube is operating normally.

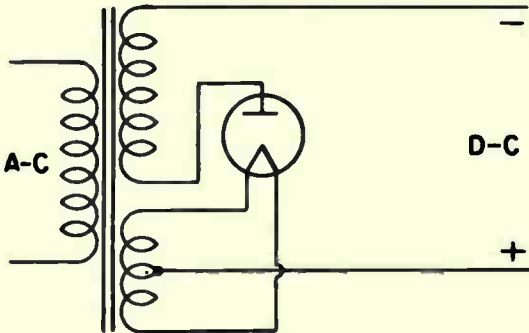
### Rectification

The simplest circuit for obtaining direct current from an alternating-current source is shown by Fig. 19-3. Current can flow only from anode to cathode in the tube, considering the conventional direction of flow, so can flow to the d-c circuit only when the polarity of the transformer anode winding is such as to make the anode positive and the cathode, through the filament winding, negative. No current flows when the transformer polarities reverse. Consequently, only the alternating half-cycles of one polarity cause current flow in the d-c circuit.

Both parts of each a-c cycle will cause flow of current in the circuit of Fig. 19-4. The anodes of the two tubes are made alternately positive and negative by reversals of polarity in the center-tapped anode winding of the transformer. Current through the tube whose anode is positive flows through the tube to the cathode, through the d-c circuit, and returns to the center tap of the transformer. One tube carries cur-

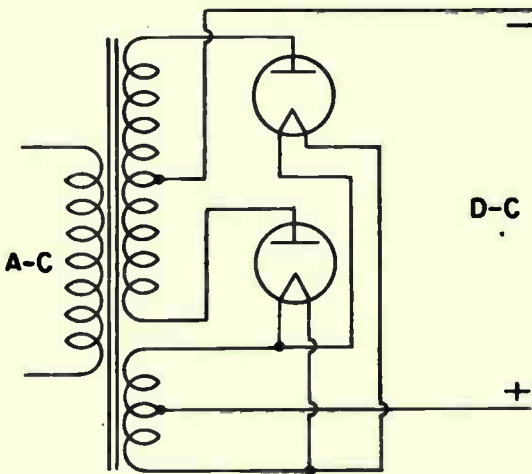
## INDUSTRIAL ELECTRONICS

rent during one half-cycle of a-c transformer voltage, and the other tube carries current during the opposite half-cycle. Thus there is current in the d-c circuit during both half-cycles of the a-c supply.



**HALF-WAVE  
SINGLE-PHASE.**

Fig. 19-3



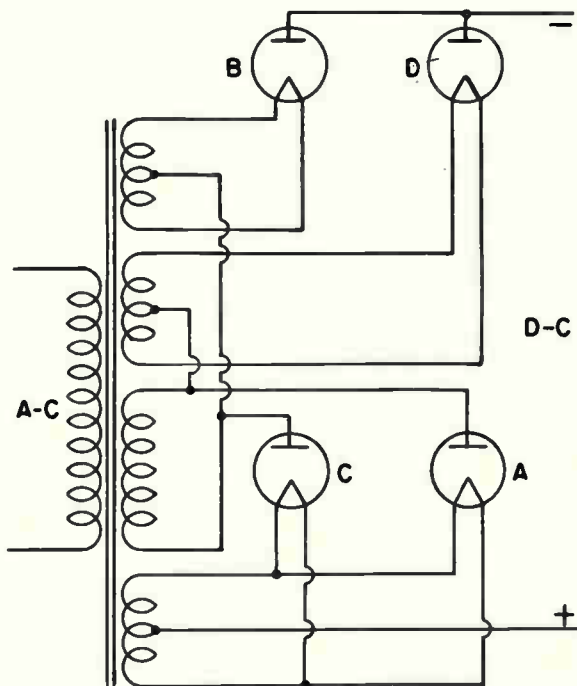
**FULL-WAVE  
SINGLE-PHASE.**

Fig. 19-4

## INDUSTRIAL ELECTRONICS

Fig. 19-5 shows a four-tube bridge rectifier of the full-wave type. When the upper end of the anode winding on the transformer is positive, current flows through tube A to the d-c circuit, through that circuit, and back through tube B to the lower end of the transformer winding. On the following half-cycle of a-c supply the lower end of the anode winding is positive, current flows through tube C, to and through the d-c circuit, and returns through tube D to the upper end of the transformer winding.

Both tubes of Fig. 19-4 may be replaced with a single full-wave rectifier tube having two anodes and one cathode. In Fig. 19-5 a similar full-wave rectifier may replace tubes A and C, and one with two anodes and two cathodes may replace tubes B and D.



FULL-WAVE, SINGLE-PHASE.  
BRIDGE TYPE.

Fig. 19-5



## INDUSTRIAL ELECTRONICS

### Amplification

When the positive side of a source is connected to the anode of a diotron, and the negative side to the cathode, the current through the tube will depend on the source voltage and also on the potential difference between control grid and cathode of the diotron.

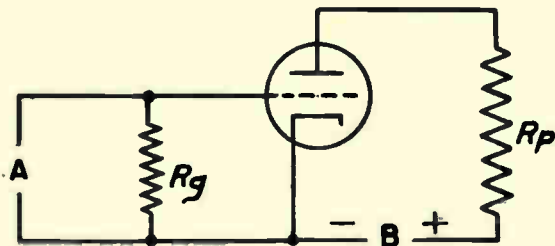


Fig. 19-6

Relatively large currents will flow when the grid is more positive than the cathode. As the grid potential is made less positive, then zero, and then negative with reference to the cathode, the anode current will decrease and finally will become zero.

When current from source **A** of Fig. 19-6 flows through resistance  $R_g$  the voltage drop in  $R_g$  is applied between grid and cathode of the tube. Whether the grid is made positive or negative with reference to the cathode depends on the polarity of **A**, while the difference between grid and cathode potentials depends on the current in  $R_g$  and its resistance. Relatively small changes of current in  $R_g$  may cause grid voltage changes so large as to cause large changes of current in the anode circuit supplied by source **B** and containing resistance  $R_p$ . Thus we have amplification of current.

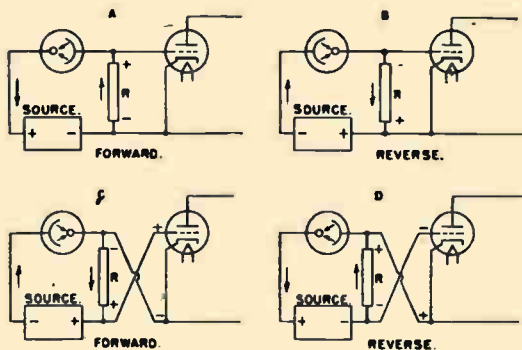
Because of the large changes of current in resistance  $R_p$  of Fig. 19-6 there will be correspondingly large changes of voltage across  $R_p$  if its resistance is great. The voltage changes across  $R_p$  may be much greater than those across  $R_g$ , and thus we have voltage amplification. Resistance  $R_p$  may represent any load in which changes of current or voltage are to be produced by changes of current or voltage in source **A** connected to the grid circuit.

### Phototube Circuits

Fig. 19-7 shows a phototube and a source of voltage and current connected across a resistor **R** in the grid circuit of an amplifier tube which is shown here as a triode. In the forward circuits, **A** and **C**, increase of radiation on the phototube cathode causes an increase

## INDUSTRIAL ELECTRONICS

of current in the anode circuit of the amplifier. Arrows indicate the direction of electron flow in the phototube circuit, which is the reverse of the conven-



Directions of electron flows in phototube circuits of the forward and reverse types when the phototube is illuminated.

Fig. 19-7

tional direction of current flow. At A electron flow in the phototube circuit makes the amplifier grid more positive with reference to its cathode. The same thing occurs at C, although grid and cathode connections are reversed.

In the reverse circuits, B and D, increase of radiation on the phototube cathode causes a decrease or a stoppage of current in the anode circuit of the amplifier tube. In both of these circuits electron flow in the phototube circuit makes the amplifier grid more negative with reference to its cathode. The amplifier tube may operate a relay or any other electrical apparatus which is to be controlled by radiation reaching the phototube cathode.

### Thyratron Operation

If the control grid of a thyratron is made negative with reference to the cathode there will be no current flow in the anode circuit until the anode-to-cathode potential difference becomes of some high value, with the anode positive. As the control grid is made less negative the break-down or the starting of anode current will occur with lower and lower anode voltages. Once anode current commences to flow, the grid has no further control and cannot either lessen or stop the flow of anode current. The anode current will stop only when the anode-cathode voltage reaches zero or thereabouts. Then the grid regains control,

## INDUSTRIAL ELECTRONICS

and the relation between grid voltage and anode voltage determines the instant at which the next flow commences in the anode circuit.

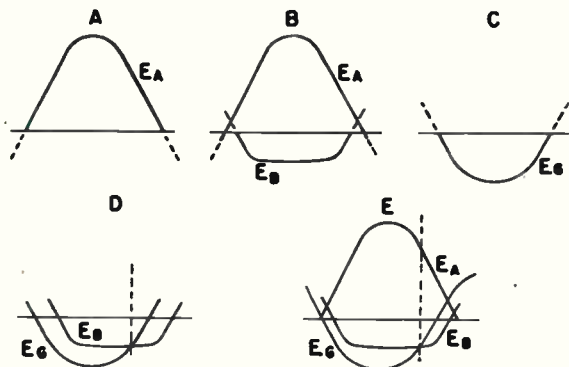


Fig. 19-8

Diagram A of Fig. 19-8 represents a half-cycle of alternating voltage which makes the anode of a thyatron positive with reference to the cathode. At B has been added a half-cycle of a grid biasing voltage which makes the control grid negative while the anode is positive with reference to the cathode. At C is represented a half-cycle of alternating voltage applied between grid and cathode. This half-cycle would make the grid negative while the anode is positive. The combination of grid bias,  $E_b$ , and grid voltage,  $E_g$ , determines the potential of the grid with reference to the cathode of the thyatron while the anode is positive. This relation is shown at D. The grid voltage produced at the instant represented by the vertical line may be assumed as that which causes break-down of the tube with the anode potential which exists at the same instant of time during the a-c cycle.

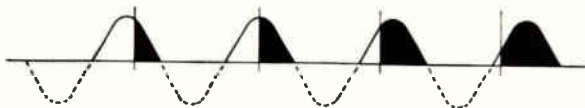


Fig. 19-9

## INDUSTRIAL ELECTRONICS

Then, even though the anode potential is positive during the entire half-cycle, break-down and flow of anode current will not occur until the instant during the cycle which is represented by the vertical line in diagram E.

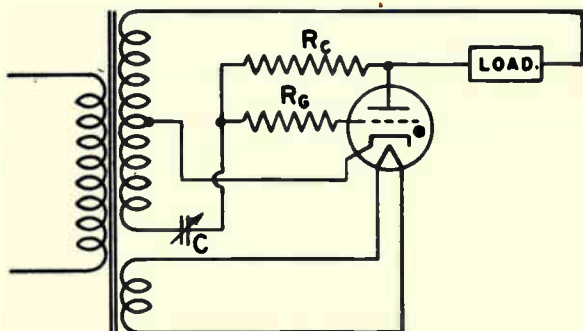


Fig. 19-10

By advancing or retarding the grid voltage in time relation to the anode voltage, or by shifting the phase of the grid voltage in relation to the anode voltage, breakdown may be allowed at various points during the half cycles in which the anode is positive. The effect is illustrated by Fig. 19-9, where shaded portions of the upper half-cycles represent the portions of each cycle during which anode current is allowed to flow. This is controlled rectification.

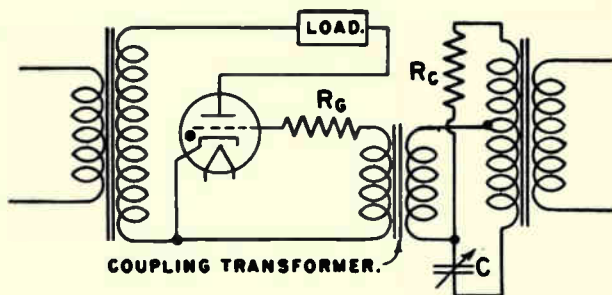


Fig. 19-11

## INDUSTRIAL ELECTRONICS

Fig. 19-10 shows a phase-shift circuit in which shifting of grid voltage in relation to anode voltage is controlled by adjustment of capacitor **C**. Shift may be controlled also by varying resistance **R<sub>c</sub>**. Resistance **R<sub>g</sub>** is placed in series with the control grid to prevent flow of excessive current in the grid circuit.

Fig. 19-11 shows a separate phase-shifting circuit connected to the grid circuit of the thyatron through a coupling transformer.

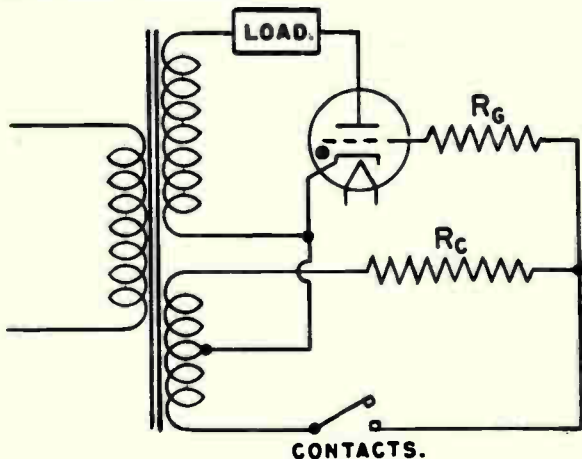


Fig. 19-12

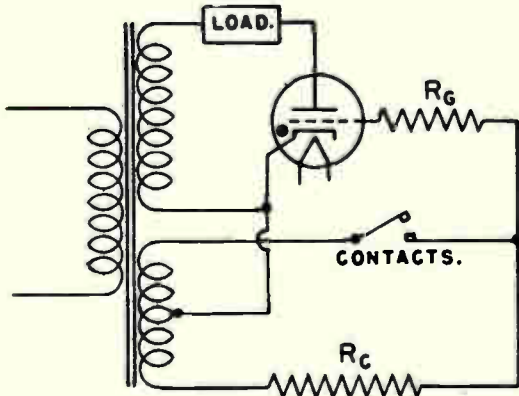


Fig. 19-13

## INDUSTRIAL ELECTRONICS

The principle of a commonly used welding control is shown by Fig. 19-15 where two ignitrons carry current for the primary of the welding transformer, and are themselves controlled by two thyratrons, T1 and T2. Breakdown or current flow in ignitrons follows the same general principles as in thyratrons, in that the ignitor of the ignitron, like the control grid of the thyratron, controls the instant at which current flow commences, but then loses control. Two ignitrons are used in order that both half-cycles may be rectified.

Fig. 19-12 shows a circuit in which closing of the contacts allows anode current to commence flowing in the thyratron and to continue flowing on each positive half-cycle so long as the contacts are closed.

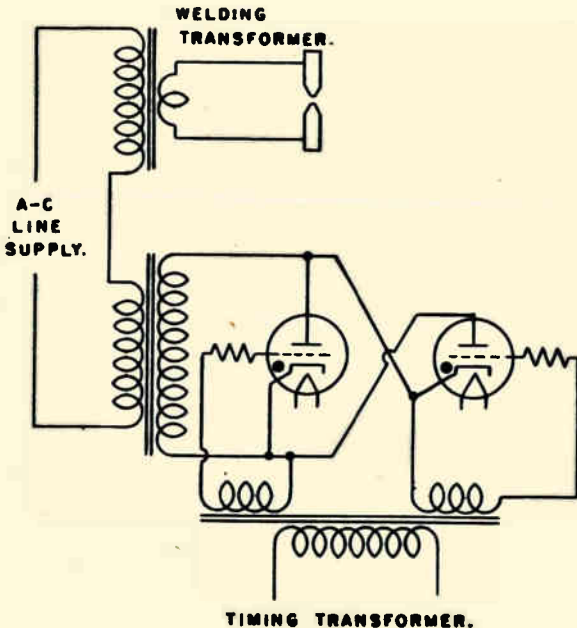


Fig. 19-14

## INDUSTRIAL ELECTRONICS

Fig. 19-13 shows a circuit in which anode current flows when the contacts are opened, and does not flow so long as they remain closed.

A circuit for impedance control of resistance welding is shown by Fig. 19-14. The welding transformer primary and the impedance transformer primary are in series. When the thyratrons are allowed to carry no current there is no current in the connected secondary of the impedance transformer, and the impedance of its primary is thus made so great that very little current flows in the welding transformer. When a weld is to be made the thyratrons are allowed to break down, current flows in the impedance transformer secondary, and its primary impedance becomes so low that a large current flows in the welding transformer.

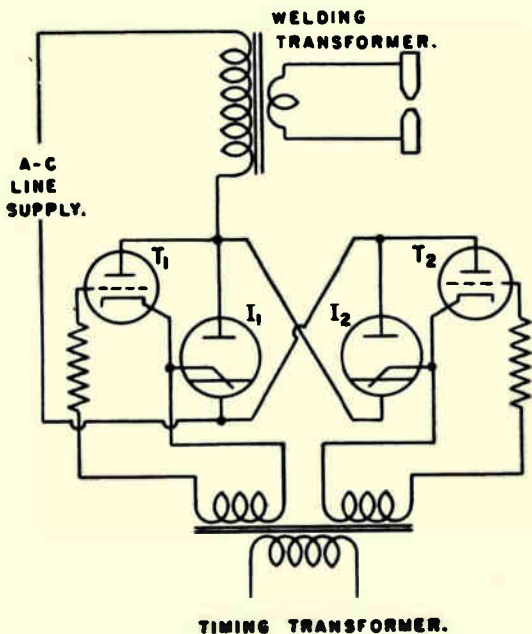


Fig. 19-15

# INDEX

## A

- Additive polarity, transformer, 198
- Air, heating of, 317
- Alarms, connections for, 118-20
- Alternating current, 7
  - average values, 10
  - circuits, laws of, 12
  - power measurements, 171
  - effective values, 8
  - motors, controls for, 296-307
  - troubles, 249-52
- Ammeter shunts, 170
- Ampere-turns, 142
- Amplifiers, electronic, 342
- Annunciator connections, 119-20
- Armored cable, rules for, 96
- Auto-transformers, 183, 187
  - installation and location, 205
  - leads, for, 203
- Auto-starters, motor, 299

## B

- Batteries, 273-81
  - dry cell, 280-81
  - storage, 274-80
    - cadmium test for, 277
    - charging methods, 278-80
    - discharge test, 276
    - testing of, 275-78
    - voltage test, 275
- Bells, connections for, 118-20
- Brake, prony, power measurement with, 162, 225
- Braking, dynamic, 292
- Branch circuits, 115-24
  - motor, 139, 223
  - types of, 122-24
- Breakers, circuit, 131-37, 218-21
- Bridge rectifier, 341
- Bridges, Wheatstone, 166, 180
- Btu, definition, 313
- Busways, rules for, 96

## C

- Cables, armored, rules for, 96
  - assemblies, 96
  - non-metallic sheathed, 98
  - service entrance, 99
- Cadmium test, storage battery, 277
- Candlepower, 319
- Capacitance, 153
  - capacitor, 156
  - distributed, definition, 153
  - parallel, 155
  - series, 155
  - tests of, 157
- Capacitive reactance, 155

- Capacitors, 154
  - capacitance of, 156
  - electrolytic, 154
  - testing of, 158
  - motors, 208, 210
    - connections of, 240-42
    - testing of, 157
- Capacity, see *Capacitance*
- current-carrying, wire, 48-51
- Cartridge fuses, 131
- Cell, battery, see *Batteries*
- Cellular metal floor raceway, 94
- Centigrade temperatures, 19-20
- Charges, electric, 153
- Charging, storage battery, 278-80
- Circuit, branch, 115-24
  - motor, 139, 223
  - types of, 122-24
  - breakers, location of, 132-37
  - motor, 218-21
  - types and uses, 131
  - diagrams, 35
  - laws of, 6
  - magnetic, 142
  - parallel, 3, 15, 17
  - series, 2, 13
- Circular mil-foot resistances, 55, 56, 67
- Code, color, resistors, 73-76
  - motor, letters for, 222
- Color coding, resistor, 73-76
- Compensator starters, motor, 299
- Compound wound motors, 208, 212
- Condenser, see *Capacitor*
- Conductors (see also *Wires*)
  - current-carrying capacity, 48-51, 58
  - diameter and area, 52, 53
  - dimensions of, 85
  - length for voltage drop, 58
  - melting temperatures, 55
  - motion in magnetic field, 151
  - number in conduit, 86-90
  - resistances, specific, 5, 55, 67, 80
  - sizes of, 52, 53, 57, 85
    - for voltage drop, 57
  - small, equivalent to large, 51
  - specific resistances, 5, 55, 67, 80
  - types and uses, 44-47
  - voltage drop calculation, 57
  - weight of, 55
- Conduit (see also *Raceways*)
  - dimensions of, 86
  - flexible, rules for, 91
  - number of conductors in, 86-90
  - rigid, rules for, 84, 85
- Connectors, wire, 110-12
- Constant potential battery charging, 279



Constants, dielectric, table of, 154  
Contactors, magnetic, 286  
Control, current, 64  
  motor, a-c, 296-307  
  d-c, 286-94  
  resistors, classification of, 308  
Controllers, definitions of, 284  
  drum, d-c motor, 293  
  wound rotor motor, 305  
  grounding of, 310  
  magnetic, a-c, 296-307  
  d-c, 291  
  motor, rules for, 309  
Converters, 266-69  
  connections for, 268-269  
  synchronous, 266, 268, 269  
Conversion tables, 18-20, 164, 314  
Copper-oxide rectifiers, 270-71  
Copper wire tables, 41-44  
Cords, flexible, 59-61  
Current  
  carrying capacities, 48-51, 58  
  eddy, definition, 143  
  induced, direction of, 151  
  resistance change due to, 68  
  single-phase a-c, 10  
  three-phase a-c, measurements, 172

## D

Demand factors, lighting, 333  
Diagrams, wiring, 21-39  
Dielectric constants, table of, 154  
  strengths, 77, 79  
Direct-current motors, connections, 247-48  
  controls for, 286-94  
  troubles, 252-55  
  welding generator from, 255  
Disconnecting means, motor, 222-25  
Dissipation, watts, in resistors, 68  
Divider, voltage, 69-73  
Drop cords, 59-61  
Drop, voltage, calculation of, 57, 58  
Drum controllers, d-c motor, 293  
  a-c motors, 305  
Dry cells, 273, 280-81  
Duty cycles, 69, 284  
  resistors for, 308  
Dynamic braking, 292  
Dynamotor, definition, 266

## E

Eddy currents, definition, 143  
Effective values, a-c, 8  
Efficiencies, small motor, 226  
Electrical metallic tubing, rules for, 90  
Electrolytes, storage battery, 274-75

Electrolytic capacitors, 154  
  testing of, 158  
Electromagnetic induction, 147  
Electromotive force, definition, 2  
Electronic tubes, types of, 335-39  
Electronics, industrial, 335-48  
Electrons, definition, 1  
Elevators, power for, 163  
Energy, definition, 159  
  conversion units for, 164  
Equivalent, table of, 18-19  
  power and energy, 164  
  power and heat, 314  
  temperature, 19, 20  
Extensions, underplaster, rules for, 92

## F

Factors, demand, lighting, 333  
Fahrenheit temperatures, 19-20  
Fans, power for, 163  
Farm light generators, 265  
Feeders, lighting, loads for, 332  
Field, electric, definition, 153  
Flexible cords, 59-61  
  metal conduit, rules for, 91  
Fluorescent lamps, 324, 325  
Flux, luminous, 319  
  magnetic, 142, 145  
  direction of, 143  
Foot-candles, 320  
  requirements in, 321  
Four-way switches, 285  
  connections for, 114  
Frequency, generator, 261  
  motor, altering of, 229  
  resonant, 12  
Full-load currents, motor, 213-15  
Full-wave rectifiers, 270-71, 339  
Fuses, location of, 132-37  
  motor, 218-21  
  types and uses, 131

## G

Generators, 261-66  
  farm light, 265  
  frequency of, 261  
  speed, 261  
  terminal markings, 262-65  
  three-wire, 264, 265  
  troubles with, 261-62  
  welding, from d-c motor, 255  
Glow tube, 337  
Grid-glow tube, 339  
Grid-pool tube, 339  
Grounding, controller, motor, 310  
  motor, 217  
  rules for, 125  
  transformer, 205  
  wiring, tests of, 127

## H

Half-wave rectifiers, 270-71, 339

Hazardous locations, definition, 126  
Heat, 313  
  specific, table, 315  
Heating, air, 317  
  electric, 313-18  
  power for, 313  
  process, 318  
  space, 317  
  water, 315  
High-rate discharge test, battery, 276  
High-voltage power, measurement of, 171  
  test, wiring, 126  
Hoists, power for, 163  
Horsepower, motor, altering of, 229  
  test of, 225  
Hot-wire meter, definition, 165  
Hysteresis, definition, 143

## I

Ignitron tubes, 387  
Illumination, 319-34 (see also *Lighting*)  
  calculations, 321-25  
  coefficients, utilization, 323  
  demand factors, 333  
  installation rules, 3331  
  requirements, 321  
Impedance, 11, 149  
  formulas, 15-17  
  triangle, 149  
Incandescent lamp ratings, 324  
Indoor wiring symbols, 28, 101-102  
Inductances, 148  
  parallel, 150  
  series, 150  
Induction, electromagnetic, 147  
  motors, see under *Motors*  
  altering characteristics of, 229  
Inductive reactance, 148  
Industrial electronics, 335-48  
Insulated conductors, types and uses 44-47  
Insulation, 77  
  dielectric strengths of, 79  
  resistance, test of, 80, 127  
Insulators, characteristics of, 79  
  materials for, 77  
  resistivities of, 80  
  specific resistances of, 80  
Internal wiring diagrams, reading, 31  
Inverted converter, definition, 266

## J

Joule, definition, 159

## K

Kenotron tubes, 335

Kilowatt-hour meters, testing of, 178  
Kirchoff's laws, 7

## L

Lamps, fluorescent, operation of, 325  
  ratings of, 324  
  illumination from, 322  
  incandescent, ratings of, 324  
  installation of, 331  
  mercury vapor, 329  
  sodium vapor, 330  
Law, Kirchoff's, 7  
  Ohm's, 6, 12, 152  
Left-hand rule, motor, 151  
Lighting, 319-34 (see also *Illumination*)  
  calculations for, 321-25  
  demand factors for, 333  
  feeders, loads for, 332  
  fluorescent, 325  
  installation rules, 331  
  mercury vapor lamp, 329  
  requirements for, 321  
  sodium vapor lamp, 330  
  switching connections for, 113-15  
Line of force, magnetic, 142  
  starters, 297  
Loads, feeder, lighting, 332  
Locations, types, definitions of, 126  
Locked rotor torques, 226, 227  
Lumens, 319  
Luminous flux, 319

## M

Magnet wire, tables, 144-46  
  turns per inch, 54  
Magnets, permanent, 141  
Magnetic circuits, 142  
  controllers, a-c, 296-307  
  d-c, 291  
  contactors, 286  
  flux, direction of, 143  
  units, 142  
Magnetizing force, 145  
Magnetomotive force, 143  
Maximum a-c values, 8  
Measurement methods, 165-82  
Measurements, conversion of, 18-20, 164, 314  
Melting temperatures, metals, 55  
Mercury arc rectifiers, 271  
  vapor lamps, 329  
Metal conduit, flexible, rules for, 91  
  rigid, rules for, 85  
  floor raceway, cellular, 94  
  melting temperatures, 55  
  weights, 55  
Meters, electric, 165-82  
  connections of, 166  
  kilowatt-hour, testing of, 173  
  moving coil, 165  
  sensitivity of, 166

**Meters—(Cont.)**  
types of, 165  
watt-hour, diagrams of, 36  
**Mil-foot resistivities, 55-57**  
**Motor-generator, 266**  
speed control by, 294  
**Motors, 207-59**  
altering to generator, 255  
alternating-current  
capacitor type, connections, 240-42  
controls for, 296-307  
-frequency, altering, 229  
induction, altering characteristics, 229  
speed test for, 227  
power factors of, 226  
repulsion, connections for, 238-39  
repulsion-induction, 239  
series wound, 236-37  
single-phase, characteristics, 226  
connections for, 235-42  
troubles with, 249-52  
slip ring, 209-11  
controls for, 302  
split-phase, connections for, 235  
three-phase, connections for, 243-45  
wound rotor, 209-11  
controls for, 302  
branch circuits, 223  
protection, 139  
code letters for, 222  
controllers, grounding of, 310  
direct-current  
compound wound, 208, 212  
controls for, 286-94  
connections of, 247-48  
series wound, 247  
shunt wound, 246  
welding generator from, 255  
disconnecting means for, 222-25  
efficiency of, 226  
full-load currents for, 213-15  
grounding of, 217  
horsepower test of, 225  
installation rules for, 309  
multi-speed, connections, 244-45  
rotation, reversing of, 212  
running protection, 136-38, 218-21  
selection of, 309  
speed of, 226  
control, motor-generator, 294  
terminal markings for, 233-48  
torque, altering of, 229  
starting, 226  
troubles with, 249-55  
types of, 208-209  
universal, characteristics, 226  
connections for, 236  
wiring for, 214, 218-21  
wound rotor, 209-11, 302

**Moving coil meters, 165**  
**Multipliers, voltmeter, 167**

## N

**NEMA resistor classes, 308**  
**Non-metallic sheathed cable, 98**  
surface extensions, 99  
waterproof wiring, 100

## O

**Ohm, 5, 63**  
**Ohm's law, 6, 12, 152**  
**Open bottom raceway, rules for, 93**  
**Overcurrent devices, location of, 132-37**  
protection, 130-39  
motor, 216-17  
transformer, 205  
**Overload devices, 130**  
protection, 130-39

## P

**Parallel capacitances, 155**  
circuits, 3, 15, 17  
inductances, 150  
**Permanent magnets, 141**  
**Permeability, 142, 145**  
**Phanotron tubes, 335**  
**Phase relations, voltage-current, 11**  
shift control, thyatron, 344  
**Phototubes, 337**  
circuits for, 342  
**Pliotron tubes, 337**  
**Plug fuses, 131**  
**Polarity, transformer, 193, 202**  
markings, 190  
testing, 192  
wiring, test of, 126  
**Polyphase currents, 10**  
motors, 209  
**Pool tubes, 339**  
**Potential drop, 57, 58**  
**Potentiometers, 63, 69**  
**Power, 159-6**  
a-c circuit, measurement, 171  
conversion units, 164  
factors, small motor, 226  
formulas for, 159-62  
heating, 313  
high-voltage, measurement, of, 171  
**Prony brake measurement of, 162, 225**  
shafting, 162  
transformer, 185  
**Process heating, 318**  
**Prony brake power measurement, 162, 225**  
**Pumps, power for, 163**

## R

**Raceways, cellular metal floor, 94**  
conductors in, 83

**Raceways—(Cont.)**  
 open-bottom, rules for, 93  
 rules for, 83  
 surface metal, rules for, 92  
 underfloor, rules for, 92  
**Range, electric, diagrams of, 37**  
**Ratings, resistor wattage, 68**  
**Reactances, 11, 148-49**  
 capacitive, 155  
 formulas for, 13-14  
 inductive, 148  
**Receptacles, circuits and types, 121-22**  
**Rectifiers, 270-71**  
 bridge, 341  
 electronic, 339  
 meters with, 165  
**Regulation, transformer, 187**  
**Relays, connections for, 119-20**  
 diagrams of, 33  
**Reluctance and reluctivity, 147**  
**Repulsion-induction motors, 209-10**  
 connections for, 239  
 motors, connections for, 238-39  
 -start induction motors, def., 209  
**Resistance starters, motor, 300**  
 welding, electronic control, 347  
**Resistances, 4, 63 (see also Resistors)**  
 box for, 64  
 change due to current, 68  
 circular mil-foot, 55, 56, 67  
 insulation, test of, 80, 127  
 parallel circuit, 3  
 resistor materials, calculations, 66  
 specific, tables, 5, 55, 67, 80  
 temperature change calculations, 56  
 coefficients of, 55, 67  
 voltmeter measurement of, 69  
**Resistors, color coding of, 73-76**  
 control, classification of, 308  
 materials for, resistance of, 66, 67  
 resistance calculations for, 66  
 specific resistances of, 67  
 temperature coefficients of, 55, 67  
 troubles, with, 73  
 watts dissipation of, 68  
**Reversing, motor rotation, 212**  
 switches, motor, 291, 306  
**Rheostats, 65**  
 motor control, 286-94  
 ratings of, 69  
**Right-hand rule, generator, 151**  
**R-M-S, definition, 9**  
**Rotary converters, 266**  
**Running protection, motor, 136-38, 218-21**

## S

**Schematic diagrams, 35**  
**Self-induction and inductance, 148**

**Sensitivity, meter, 166**  
**Series capacitances, 155**  
 circuits, 2, 13  
 inductances, 150  
 -parallel circuits, 4  
 wound motors, 208, 212  
 connections for, 236-37, 247  
**Service entrance cable, 99**  
**Shaded pole motors, 208, 210**  
**Shunting, power transmitted by, 162**  
**Sheathed cable, non-metallic, 98**  
**Short circuit test, wiring, 127**  
**Shunt wound motors, 208, 212**  
 connections for, 246  
**Shunts, ammeter, 170**  
**Signals, connections for, 118-20**  
 symbols for, 117  
**Sine wave, definition, 8**  
**Single-phase motors, connections, 235-42**  
 troubles with, 249-52  
 power measurements, 171  
 transformers, 193-99  
**Slip ring motors, see Motors, wound rotor**  
**Sodium vapor lamps, 330**  
**Solderless connectors, 110**  
**Space heating, 317**  
**Sparking voltages, 79**  
**Specific heats, table of, 315**  
 resistances, tables, 5, 55, 67, 80  
**Speed controls, motor, a-c, 296-307**  
 motor, d-c, 286-94  
 motor-generator tor, 294  
 generator, 261  
 induction motor, test of, 227  
 motor, altering, 229  
 small sizes, 226  
 variator, 295  
**Splicing, wire, 105-10**  
**Split-phase motors, 208, 209**  
 connections for, 235  
**Squirrel cage motors, 209, 211**  
 (see also under *Motors*)  
**Star-delta starting, 307**  
**Starters, motor, a-c, 296-307**  
 auto-, 299  
 d-c, 286-94  
 line, 297  
 resistance, 300  
 star-delta, 307  
**Storage batteries, 274-80**  
 charging of, 278-80  
 testing of, 275-78  
**Subtractive polarity, transformer, 198**  
**Surface extensions, non-metallic, 99**  
 metal raceway, rules for, 92  
**Switches, 25, 283**  
 drum, 293  
 four-way, 114, 285  
 lighting, connections for, 113-15  
 reversing, motor, 291, 306  
 three-way, 114-285  
**Synchronous converters, 266, 268-69**

## Synchronous—(Cont.)

- motors, 209, 211
- speed, motor, 209
- Symbols, electrical, 21-30
- electronic tube, 336, 338
- signal and alarm, 117
- wiring, building, 28, 101, 102
- industrial, 103, 104

## T

- Temperature, 315
  - coefficients of resistivity, 55, 56, 67
  - conversions, 19, 20
- Terminal markings, converter, 268-69
  - generator, 262-65
  - motor, 233-48
  - transformer, 193-202
- Thermal devices, 130, 131
- Three-phase motors, connections, 243-45
  - power measurements, 172-77
  - transformers, 188, 194-202
- Three-way switches, 285
  - connections for, 114
- Three-way generators, 264-65
- Thyratron tubes, 337
  - operation of, 343
- Torques, locked rotor, 227
  - motor, altering, 229
  - starting, small motor, 226
- Transformers, 183-92
  - connections, single-phase, 193-99
    - three-phase, 194-202
    - formulas for, 187
    - installation rules, 203
    - instrument, 171
    - locations, rules for, 203
    - polarity markings for, 190, 193-202
    - testing of, 192
    - power output of, 185
    - principles of, 183
    - regulation of, 187
    - three-phase, 188
- Troubles, generator, 261-62
  - motor, 249-55
  - resistor, 73
  - wiring, tests for, 128
- Tubes, electronic, 335-39
- Tubing, dimensions of, 86
  - electrical metallic, 90

## U

- Underfloor raceways, rules for, 92
- Underplaster extensions, rules for, 92
- Undervoltage units, 284
- Universal motors, 208, 210
  - connections for, 236

## V

- Variator, speed, 295
- Vibrating rectifiers, 271
- Voltage, breakdown of insulators, 79
  - divider, 64, 69-73
  - drop calculations, 57-58
  - sparking, 79
  - three-phase, measurement, 173
  - to ground, 126
- Voltmeter, insulation test with, 81
  - multipliers for, 167
  - resistance measurement with, 69

## W

- Water heating, 315
- Waterfall, power of, 164
- Waterproof wiring, non-metallic, 100
- Watt-hour meter diagrams, 36
- Wattmeters, connections for, 171-78
- Watts dissipation, resistor, 68
- Weights, metals, 55
- Welding, electronic control for, 347
  - generator, from d-c motor, 255
- Wheatstone bridges, 166, 180
- Windings, transformer, 183
- Wires (see also *Conductors*)
  - connectors for, 110-12
  - current-carrying capacities, 48-51, 58
  - diameters and areas of, 52-53
  - dimensions of, 85
  - large, equivalent to small, 51
  - length, for voltage drop, 58
  - magnet, tables for, 144-46
    - turns per inch, 54
  - number in conduit, 86-90
  - size of, 52-53, 57
  - small, equivalent to large, 51
  - splicing of, 105-10
  - tables, copper, 41-44
  - types and uses of, 44-47
- Wireways, rules for, 95
- Wiring diagrams, reading, 21-39
  - motor, 214
  - rules for, 83
  - symbols for, 21-30
    - interior, 101-102
    - industrial, 103-104
  - test of, high-voltage, 126
  - trouble, test for, 128
- Work, definition, 159
- Wound rotor motors, 209, 211
  - controls for, 302

## X

- X-ray tubes, 339