

SPECIALIZED TELEVISION ENGINEERING

TELEVISION TECHNICAL ASSIGNMENT

FREQUENCY MULTIPLYING; THE VACUUM TUBE AS A DETECTOR

Copyright 1947 by
Capitol Radio Engineering Institute
Washington, D. C.

735D

- TABLE OF CONTENTS -

THE VACUUM TUBE AS A DETECTOR

	Page
HARMONIC FREQUENCIES	1
CRYSTAL CALIBRATORS	2
FREQUENCY DOUBLING AND TRIPLING	5
DETECTOR ACTION (DEMODULATION)	10
TYPES OF MODULATION	11
BEAT FREQUENCIES	12
WHY DEMODULATION IS NECESSARY	13
GRID LEAK AND CONDENSER DETECTOR	16
POWER AND LINEAR DETECTORS	18
GRID LEAK DETECTION OF LARGE SIGNAL VOLTAGES	24
THE DIODE DETECTOR	27
INFINITE IMPEDANCE DETECTOR	34
MIXER CIRCUITS FOR SUPERHETERODYNE RECEIVERS	36

THE VACUUM TUBE AS A DETECTOR

HARMONIC FREQUENCIES: It is often desirable to use an oscillator operating at a comparatively low frequency, particularly when using crystal control, to furnish excitation to an amplifier tube which is to deliver power to an antenna circuit at a frequency higher than that of the excitation circuit. This is called frequency multiplying and the output is at a frequency corresponding to one of the harmonics of the original or fundamental frequency. By "Harmonic" of a frequency is meant a multiple of a frequency, for example, twice the frequency, three times, one hundred times, etc.

A few writers sometimes speak of double the fundamental frequency as the first harmonic, triple as the second harmonic, etc. A much more simple method now in almost universal use is to refer to the *fundamental* frequency as the *first* harmonic, double the frequency as the second harmonic, fifty times the fundamental as the fiftieth harmonic, etc. The advantage of this is, that to find the frequency corresponding to any given harmonic of a known fundamental frequency, it is only necessary to multiply the fundamental by the desired harmonic. For example, to determine the frequency corresponding to the 26th harmonic of 25 kilocycles; $25 \times 26 = 650$ KC/s. This system will be used throughout this text.

There are two general types of harmonics, natural harmonics and forced harmonics.

Natural harmonics are developed to some extent in every type of alternating current circuit. This can be shown by the mechanical analogy of a wire suspended between two fixed points. If the wire is caused to vibrate it will shape into two large loops each equal in length to one-half the total length of the wire. Smaller loops will also develop equal to $1/4$, $1/6$, $1/8$, $1/10$, etc., the total length of the wire. These are the harmonic vibrations of the wire and the wire will vibrate to some extent at frequencies determined by all of the loops. If a single key on a piano is struck, the tone produced will be due to a combination of the fundamental and all of the harmonic frequencies strong

enough to be audible. The difference in tone between a given note on one instrument and the same note on another instrument is determined by the number and strength of the various audible harmonics. Thus one is able to hear a given note played on a piano and the same note played on a violin, and state which is piano and which is violin.

In the same manner a radio frequency circuit consisting of inductance and capacity, such as an antenna circuit, not only contains current at its fundamental or resonant frequency but also at a large number of the harmonics or multiples of that frequency. Harmonics are developed in the tube itself due to the non-linearity of its several important characteristics and due to circuit adjustments.

The natural or circuit harmonics are usually very weak compared with the fundamental frequency, but a circuit may be so designed that a large number of the harmonics can be picked up with a comparatively sensitive receiving circuit. This is the principle of many calibrating devices and frequency standards.

CRYSTAL CALIBRATORS: One type of calibrator uses a crystal controlled oscillator, the plate circuit of which consists of a Universal wound coil possessing a very large amount of inductance and a very small distributed capacity. The coil is so designed as to have a resonant frequency slightly higher than the frequency of the oscillating crystal, the quartz crystal being used to maintain a very constant fundamental frequency. A parallel circuit in which the inductance is very high and the capacity very small will act as a high impedance over an extremely wide band of frequencies. This was shown in the study of R.F. choke coils. Therefore the impedance of the oscillator plate circuit will be comparatively high over a wide frequency band and considerable power will be delivered into that circuit by the vacuum tube at a number of harmonics frequencies. The plate circuit impedance curve is shown in Figure 1.

The circuit is resonant at a frequency F_r at which point the impedance of the circuit is very high. The circuit is operated at frequency F_o , somewhat lower than the resonant frequency of the circuit. (F_o is the frequency of the crystal.) It will be seen that at this frequency the circuit acts as a high inductive reactance, the proper condition for stable operation of the crystal.

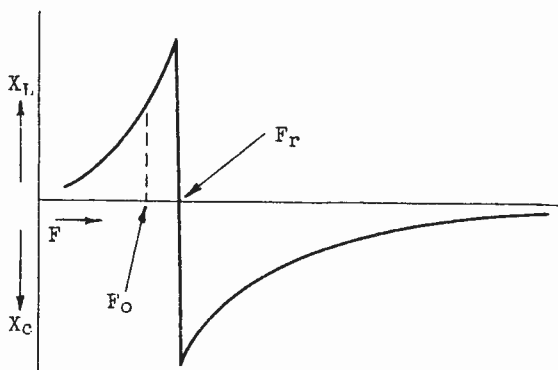

Fig. 1.

At frequencies higher than the resonant frequency F_r , the circuit acts as a capacity reactance, and from the curve it is seen that the reactance falls off very gradually. Thus the plate output impedance is fairly high over a wide band of frequencies higher than the fundamental of the crystal.

This type of circuit will develop a great number of harmonics. In fact, with a fairly sensitive receiver, using a low power transmitting tube in the oscillator, harmonics as high as the 150th harmonic may ordinarily be picked up with close coupling.

Any tube oscillator can usually be depended on to develop considerable harmonic energy due to the somewhat high operating efficiency. Usually a grid leak is employed to furnish the operating bias and with tight plate-grid circuit coupling the bias ordinarily will be so great as to cause the tube to operate as a Class C amplifier with the bias considerably beyond plate current cut-off. Thus the A.C. component of plate current will be badly distorted, as explained in an earlier lesson, with corresponding strong harmonic components. It will be seen that the plate output circuit design as outlined above is just the opposite to that of the linear amplifier in which harmonic suppression is desired. The harmonics developed by plate current distortion are not natural circuit harmonics.

Calibrators of this type are used to calibrate and check the frequencies on a heterodyne type of frequency meter or signal generator. If a 50 kilocycle crystal is used, a harmonic will develop every 50 kilocycles. Thus to check the frequency of a signal generator or oscillating receiver at 500 kilocycles it is merely necessary to couple the signal generator to the calibrator (or receiver) get both in an oscillating condition and tune the signal generator (or receiver) back and forth around its 500 kilocycle setting until a beat note is picked up. Then set the signal generator at exact zero beat with the cali-

brator. The 10th harmonic of the 50 kilocycle oscillator is 500 kilocycles. When set at the exact zero beat the signal generator will also be oscillating at exactly 500 kilocycles. A number of points may be checked along the calibration curve and the difference between those points and the original curve noted. If it is desired a new curve may be plotted using those points every 50 kilocycles. Otherwise a correction factor may be noted and used when checking against the original calibration curve.

Figure 2 shows a workable circuit of a crystal calibrator. Tube 1 is the oscillator tube, the frequency of oscillation being determined by the dimensions of the crystal. The plate circuit L_1 is designed as explained above to bring out a large number of harmonics of the crystal frequency. C is a bypass condenser across the plate supply. The grid leak GL is used to furnish oscillator bias and to prevent the oscillator tube from blocking.

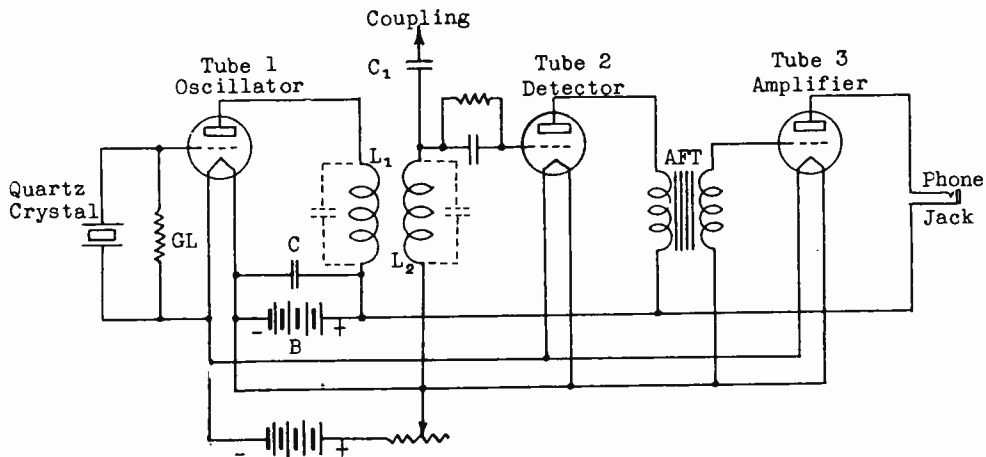

Fig. 2.

Tube 2 is a detector coupled by means of L_2 very closely to the oscillator circuit. The grid leak and condenser method is used for detection. The oscillator or signal generator to be calibrated is coupled to this circuit by means of the coupling terminal and condenser C_1 . The frequency to be checked and some harmonic of the crystal oscillator frequency are mixed in coil L_2 , and the beat note produced by tuning the signal generator or the receiver being calibrated. This beat note is then amplified at audio frequency by Tube 3.

This is a very practical, accurate, and simple calibrating device and is

not difficult to construct and operate. The accuracy of the standard frequency is determined entirely by the degree of accuracy at which the crystal oscillator frequency is maintained. Thus for a really high degree of accuracy the crystal oscillator must operate in a constant temperature compartment, or a zero temperature coefficient crystal must be used.

FREQUENCY DOUBLING AND TRIPLING: In addition to the natural circuit harmonics, very strong *forced* harmonics may be developed in the *tube* under certain operating conditions.

Harmonics are developed in a vacuum tube whenever the plate current is distorted. The distortion of the plate current from the sinusoidal form may be such as to bring out some particular harmonic stronger than the others. For example, if it is desired to operate an oscillator at 4000 KC/s and obtain 8000 KC/s in the plate circuit of an amplifier, it will be necessary to accentuate the second harmonic of the fundamental frequency. On the other hand if it is desired to obtain, from the same 4000 KC/s source, 12,000 KC/s in the plate circuit of the amplifier, it will be necessary to bring out the *third* harmonic, i.e., three times the fundamental frequency.

Frequency multiplying is particularly valuable at high frequency when the frequency is controlled by means of a quartz crystal. When using a quartz crystal to control the frequency, the frequency depends primarily upon the thickness of the crystal. At 4000 KC/s the crystal is thin, approximately .029 inches, for the X cut crystal. In order to obtain directly frequencies higher than this the thickness will have to be still further decreased. At the very high frequencies the crystal will be too fragile for power operation. Therefore to use crystal control at high power at frequencies higher than about 4000 KC/s, it is usual to use a frequency multiplying system. In earlier study of tube operation it has been found that the form of the plate current can be controlled by the form and magnitudes of the different voltages on the grid; i.e., by the proper combination of grid bias and grid excitation voltages the plate current can be distorted and forced to take practically any desired form.

To double the frequency and obtain a fairly large power output, one complete voltage alternation across the plate output circuit must take place in *one-half* the time of one complete alternation of grid excitation voltage. Thus

one-half cycle of plate voltage must occur in the time of one-quarter cycle of grid excitation. During the rest of the grid voltage cycle the tube must be idle, allowing the plate output circuit to oscillate freely for the remainder of two complete cycles before receiving another "kick" from the plate voltage variation. A study of Figure 3 will help to make this clear.

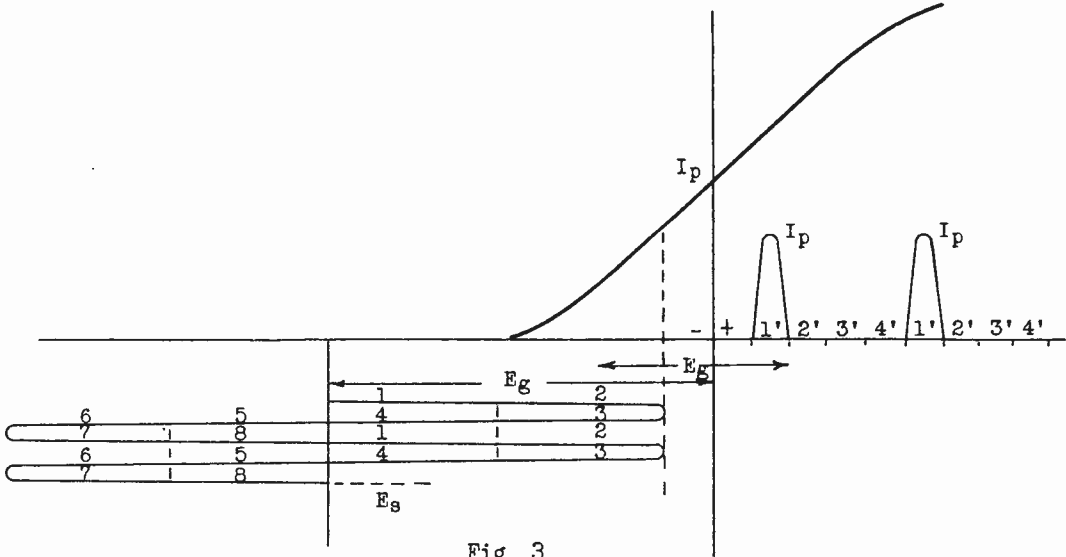

Fig. 3.

First observe the large value of negative bias E_g that is used. In this case the bias is approximately twice the value required to bring the plate current to zero. At first it would seem that this would permanently block the tube and prevent operation. This, however, is taken care of by the use of practically double the normal value of excitation, E_s . In other words the tube is operated essentially as a Class C amplifier but not excited to saturation.

In Figure 3 two complete cycles of grid excitation voltage are shown and each cycle is divided up into eight parts. Starting with cycle number 1; in part 1 of the cycle the grid voltage is still of such high negative value that the tube is blocked. In part 2 the tube unblocks because the grid is becoming less negative. During this portion of the cycle the plate current I_p is rising. During part 3 the grid is again swinging more negative and the plate current falls off to zero. During parts 4, 5, 6, 7, 8, and 1 of the next cycle, the tube is blocked and therefore idle so far as plate current is concerned. It is

evident from this that plate current flows during only two divisions of the cycle of grid excitation; during the other six divisions of the cycle the tube is idle.

Thus plate current flows only one-quarter of the time, the tube being blocked the other three-quarters of the grid excitation cycle. The working and idle times are shown in the plate current pulsations with the time divided into sections, 1', 2', 3', 4'. 1' represents the time of 2 and 3 on the grid voltage curve; 2' represents grid voltage 4 and 5; 3' represents grid voltage 6 and 7; 4' represents grid voltage 8 and 1. The working cycle of the tube really begins at 2 and not at 1 on the grid voltage (E_g) curve.

When the plate current is rising the plate voltage is falling off; and when the plate current is decreasing the plate voltage is swinging back to normal. Even though the plate current remains at zero the plate voltage completes its cycle, swinging to a value as high above normal as it went below normal while the plate current was rising. This is due to the "fly-wheel" effect of the tuned plate load circuit.

However, since the first complete alternation of plate voltage occurred in one-quarter of the time of the grid voltage cycle, then the second alternation of plate voltage must take exactly the same time as the first. Thus, one complete cycle of plate voltage has occurred in half the time of one cycle of grid excitation. During the remainder of the grid voltage cycle the tube is idle. To develop this strong second harmonic the plate load circuit must consist of a resonant LC circuit tuned to twice the frequency of the exciting voltage. The current in this circuit will complete one cycle during the cycle of plate voltage. During the remainder of the period of time during which the tube is idle, the current in the tank circuit will complete a second cycle. At the end of the second cycle the tube will again function due to the flow of plate current and the entire operation will be repeated.

Figure 4 shows the phase relations and time intervals involved in the above explanation. This diagram shows very clearly the actual operation of the tube when doubling the frequency. The single pulse of plate current causes a complete cycle of plate voltage across the tank circuit in one-half the time of one grid voltage cycle. Since the current in the output circuit depends

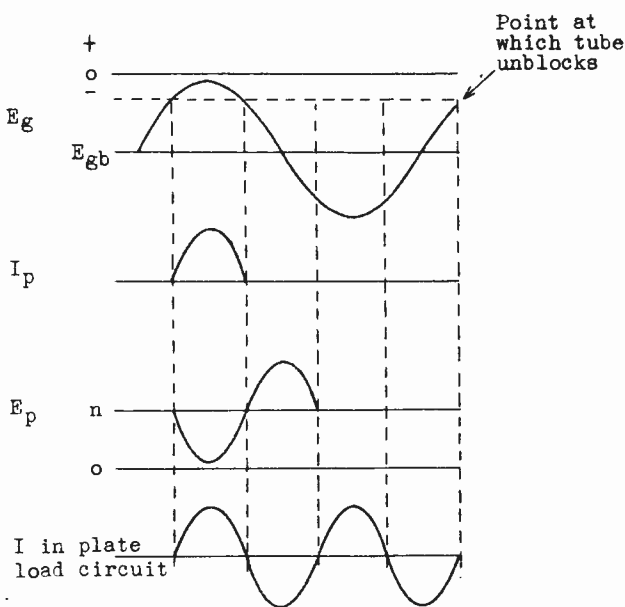

Fig. 4.

directly upon the plate voltage variations, this current must be at the same frequency as that of the plate voltage variations or twice the frequency of the grid excitation voltage.

The frequency may be tripled by still further increasing the negative bias and grid excitation voltages, and tuning the plate output circuit to three times the frequency of the grid voltage. The bias and excitation voltages should be such

that plate current flows only one-sixth of the time.

The principal disadvantage of this method of frequency multiplying in a power tube is the difficulty in obtaining a large output from the tube. This is *not* because the tube is not worked efficiently; on the contrary, with such method of operation the efficiency is exceptionally high because plate current flows for such a short period of time that very little power is expended in the tube.

For that same reason, however, it is difficult to obtain a large output *because it is difficult to make the input sufficiently large.* The power in the output circuit can be only a certain percentage of the input power, and even though that percentage is high, if the input is low the output must be correspondingly low. The input is low due to the fact that current flows for such a small part of the time and the tube is idle for such a great portion of the time that the effective plate current is small. Since the power input is the product of the D.C. plate voltage times the average plate current this results in the input power being comparatively low. When frequency doubling, the average D.C. plate current as indicated by the plate current ammeter will be approx-

imately, $I_b = .636I_{\text{peak}}/4 = .159I_{\text{peak}}$. Thus peak plate current, $I_{\text{peak}} = I_b/.159$. The peak plate current is definitely limited by the filament emission and the excitation voltage is limited by the permissible grid current.

The power input limitations are counteracted to some extent by the cool operation of the tube which allows the plate voltage to be considerably increased with safety, and by the very high operating efficiency.

Thus to obtain a comparatively large output at double the frequency of grid excitation, the plate voltage should be increased to the highest safe value and the grid bias and excitation voltages correspondingly increased, maintaining of course the relation that allows plate current flow during the correct period of time during each excitation cycle, 1/4th for doubling and 1/6th for tripling.

One advantage of this system for high frequency operation is the fact that no system for neutralizing the plate to grid capacity of the doubler tube is needed to prevent amplifier self-oscillation. The tube will not oscillate because of the great difference in frequency between the plate and grid circuits.

In adjusting the tube to operate on the double frequency, increase the negative bias to approximately double the plate current cut-off value. Then adjust the plate tank circuit to obtain maximum current at double the excitation frequency. If there is any doubt as to whether the output is at the double or triple frequency, check it with a frequency meter. The plate tap is adjusted to give the maximum output. Then vary the negative bias and excitation voltage until the greatest output is obtained at the double frequency. This will normally result when the negative bias is approximately double that required for D.C. plate current cut-off as shown in Figure 3. The plate voltage should be considerably higher than that normally used for straight amplification if maximum power output is desired. If the excitation voltage is increased so as to swing the grid considerably positive, the bias must also be increased in order to maintain the proper time relation.

If it is desired to use the crystal controlled high frequency transmitter for radio telephony, it is necessary to develop the desired high frequency by multiplying before applying it as excitation to a modulating amplifier. This is obvious from Figure 3. If the excitation voltage contains the modulation

component, the lower modulation peaks will be cut off. If plate modulation is attempted with the conditions as shown in Figure 3, the desired time relation between the various voltages and currents will be destroyed with resulting distortion. Thus in such a transmitter all frequency multiplying should be done in low power stages and then the desired final frequency applied as excitation to the final R.F. amplifier which should be operated Class C for high level modulation.

The power output of a frequency multiplier tube is almost exactly inversely proportional to the order of the harmonic. A properly adjusted multiplying stage will develop approximately from 60 to 70 per cent as much output at the second harmonic as at the fundamental, with values for the third, fourth and fifth harmonic outputs corresponding roughly to 40, 30 and 25 per cent of the output at the fundamental. This apparently large amount of power output at the higher frequencies is obtained, however, at the expense of excessively large driving power. This makes the practical use of harmonic generators chiefly limited to the use of second and third harmonic output with the fourth being occasionally employed. It is cheaper and more economical to use two doublers than a single quadrupler as an example.

Since heating of the plate limits the power output for a given tube, those with thoriated or solid tungsten filaments are more satisfactory for use as frequency multipliers. It is also desirable to use tubes with a large mutual conductance and, if triodes, with low plate resistance. The modern line of pentodes available are excellent for frequency multiplication.

The use of two tubes with the input circuit in push-pull and the output circuit in parallel has been found advantageous in that the fundamental frequency may be balanced out resulting in a higher efficiency. This type of circuit could also employ a single tube which has two triodes in the same envelope.

DETECTOR ACTION. (DEMODULATION).

By detector action, sometimes called demodulation, is meant the conversion of radio frequency signals in the form of wave trains or modulated radio frequency into direct current pulsations at a frequency corresponding to the number of wave trains per second. This second frequency may or may not be in the audible range.

TYPES OF MODULATION: The wave trains may be developed at the transmitter by the use of a damped wave transmitter, such as a spark transmitter which produces a wave train consisting of a certain number of cycles at radio frequency each time a condenser discharges through a spark gap. The number of cycles in each wave train depends upon the decrement of the circuit, i.e., upon how rapidly the energy in the antenna circuit dies down. This type of wave train is shown in Figure 5.

Wave trains may be produced in the output of a C.W. transmitter by breaking up the output by means of a "chopper" either in the antenna or in the grid circuit of the oscillator tubes. This will produce wave trains in which the alternations are of comparatively uniform amplitude, as shown in Figure 6.

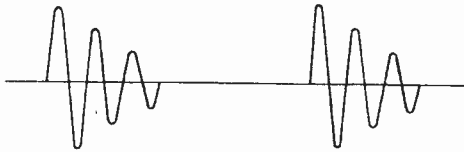

Fig. 5.

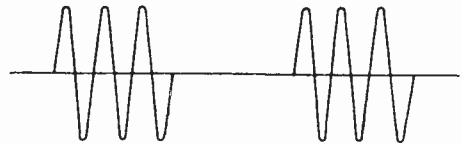

Fig. 6.

Wave trains will be produced at the transmitter if the transmitter is of the A.C.W. type. (Such a transmitter usually employs two tubes, the plate of each being connected to one side of a high voltage transformer secondary which is tapped in the center for the filament connection. Alternating current is supplied to the primary making first one plate and then the other plate positive with respect to the filament. Since the supply voltage is in the form of a sine curve the plate voltage will rise and fall in a similar form thus modulating the output.) This form of output is shown in Figure 7.

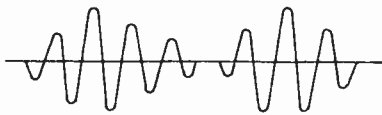

Fig. 7.

All of the three methods of producing wave trains could modulate the antenna current at the same frequency and produce the same fundamental frequency note at the receiver.

The tones of all, however, would be somewhat different in the same way that the tones of two different types of musical instruments playing the same note sound differently due to the difference of harmonic components.

Modulation at a large number of simultaneous frequencies, as by voice and music in the case of a broadcast transmitter, will produce variations in the

power output at a large and complex number of frequencies. This is shown roughly in Figure 8. With such an output the degree of modulation can vary

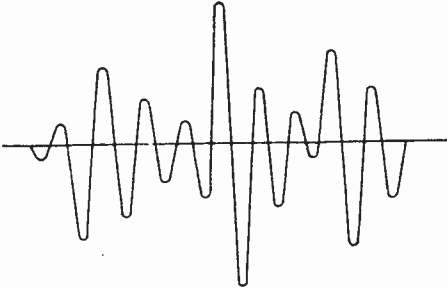

Fig. 8.

over wide limits depending upon the volume produced by the source of modulation acting upon the microphone. For example, at one instant an orchestra may be playing softly and the next instant may produce a very loud note. This will cause differences in the degree of modulation for the tones of varying volume, and in the case of a

symphony orchestra the variation in sound level may be as great as 60 or 70 DB.

All of the above methods have been used for the sole purpose of causing variations in the output of the transmitter at an audible frequency.

If this is not done at the transmitter (in the case of a continuous wave transmitter in which the amplitude of the alternations of current in the antenna are constant as long as the key is closed) then it must be done at the receiving end.

One of the first methods of breaking up the incoming C.W. energy at the receiver was the Poulson ticker, a revolving disc with alternate conducting and non-conducting segments, placed in series with the antenna to break up the continuous wave energy into wave trains at an audible frequency. This was used for reception of the arc transmitters in past years.

BEAT FREQUENCIES: A better method is to mix a locally generated A.C. voltage of a frequency differing by a predetermined amount from that of the frequency of the received signal. When one frequency is mixed with another in any non-linear impedance, such as the mixer stage in a superheterodyne or the detector in an autodyne receiver, there always results additional frequencies in the output. A non-linear device is one in which the functional relationship between the input and the output is not represented graphically by a straight line. Examples of non-linearity are (1) Iron-core reactors operated at or near saturation of the core where the current flowing is not of the same shape as the voltage causing it, (2) Vacuum tubes operated over the non-linear charac-

teristic of the dynamic characteristic, (3) Rectifier circuits wherein the A.C. voltage applied results in a pulsating D.C. current output and indeed (4) the human ear, the response of which is not directly proportional to the sound intensity but related in a logarithmic way. There are many other examples.

The beat frequencies produced are many, there is the beat which is the sum of the mixed frequencies, there is the beat which is the difference and there are beats between the beats and the two mixed frequencies which produce other beats. Normally the beat frequency which is of the greatest intensity is the difference of the parent frequencies. If a tuning fork of 500 cycle pitch and another fork of 700 cycle pitch were sounded together, the normal ear will "hear" only the difference frequency of 200 cycles. Trained observers have noted the sum frequency of 1200 cycles. The other beats are too weak to affect the human ear but have been observed with sensitive sound detecting apparatus. At radio frequencies, a local oscillator operating at 1465 KC/s beating with a received signal of 1000 KC/s produces in the output of the mixer tube, among others, a difference frequency of 465 KC/s. This is known as the intermediate frequency in the superheterodyne receiver.

If an oscillating detector is employed, it will be tuned to a frequency different from the receiver signal by an amount to produce a beat at an audio frequency. A marine operator using such a detector system in his receiver would adjust his oscillating detector circuit to 1000 cycles off the received signal so that an audible note is produced in the head telephones. If he is standing watch on 500 KC/s, his oscillating detector is tuned to 501 KC/s or 499 KC/s to produce a 1 KC/s or 1000 cycles per second note. Such a receiver circuit is in general known as an autodyne receiver circuit, or, perhaps more popularly as a regenerative receiver. In the case of the intermediate frequency, the beat frequency is beyond audibility, in the second case of the autodyne receiver within the audible range. The applications of detectors will be covered in a later lesson dealing specifically with receiving equipment.

All of the above methods of breaking up the energy into wave trains are commonly used. The next step is to see how the wave trains, occurring at an audible frequency, are caused to actuate the reproducer in the receiver.

WHY DEMODULATION IS NECESSARY: The vacuum tube amplifies any signal voltage

applied to the control grid. The grid voltage variations cause the plate current to vary around some normal D.C. value. If the output circuit of the tube consists of a pair of telephones, the current variations at radio frequency will take place to some extent, through the telephone windings. The radio frequency current variations, however, will have no effect on the telephone diaphragms for two reasons: First, the inertia of the telephone diaphragms prevents them from vibrating at radio frequency; second, the number of turns in the windings is so great that, practically, the radio frequency will be by-passed by the capacity of the windings. (In the above it is assumed that the current variations are equal above and below the normal value.) Thus even with the input in the form of wave trains occurring at an audible frequency, there will be no response in the phones because the net variations in plate current, (equal in amplitude above and below normal), are zero.

To cause an audible response in the phones the plate current must be distorted in such a manner that the *average* plate current during a wave train will be either *greater* or *less* than the normal D.C. plate current. If this is done the current will vary through the windings of the telephones, either above or below the normal value, each time a wave train is impressed on the grid. Then if the wave trains are occurring at an audible frequency the telephone diaphragms will vibrate at this same audible frequency and the electrical energy will be changed into sound energy.

It has been shown in earlier lessons that to amplify without distortion, the grid voltage must be held at such a value (usually negative) that the tube is operated on the straight portion of the plate current-grid voltage curve. Conversely, to deliberately distort the output, the grid should be biased at such a value that the tube is worked on the *bending* portion of the curve. This is shown in Figure 9. A sufficient negative biasing voltage is used to hold the normal plate current at point X. With a receiving tube of the 6C5 type with 250 volts on the plate, the biasing voltage should be about 17 volts negative. When a wave train of grid excitation voltage due to the incoming signal is impressed between the grid and filament, the plate current varies as shown. Due to the shape of the $E_g I_p$ curve, and the fact that the tube is operated at the bend, the variations of plate current above normal are greater than the variations below normal.

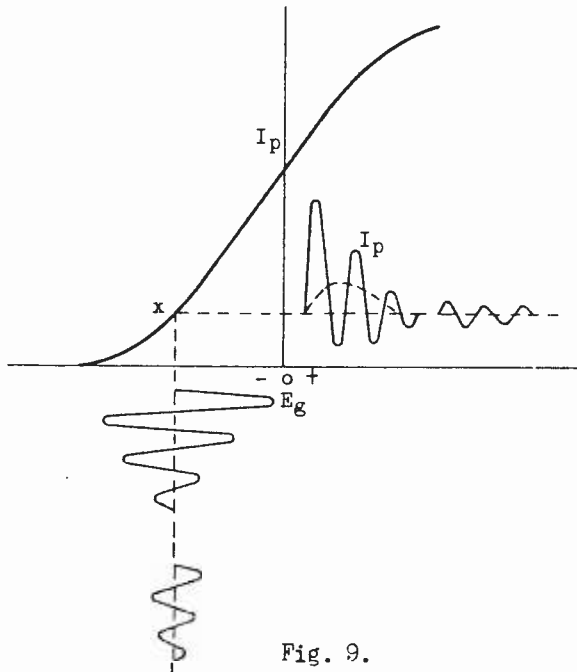

Fig. 9.

The average variation is no longer zero; the average plate current during a wave train is greater than the normal plate current as shown by the dotted line. This will cause an average increase of current through the telephone windings during the wave train and a consequent depression of the diaphragms. If a series of wave trains occurs at an audible frequency, the telephone diaphragm will vibrate at that frequency.

This is known as the negative bias or plate method of detection. It has the disadvantage

of not being very efficient for weak signals. The reason for this is shown in Figure 9, on the second small wave train. The bend of the $E_g I_p$ curve is gradual and not sharply defined. Therefore for small variations of grid voltage the plate voltage variations above and below normal are about equal and no appreciable effective variation of I_p at an audible frequency will result. Thus for very weak signals this method of detection is very inefficient.

A detector, operating on the bend of a curve as in Figure 9, where the bend is long and gradual due to the tube characteristics and the combination of voltages used, is called a "square law" detector because the rectified output is approximately proportional to the square of the signal voltage applied to the grid. Thus the use of radio frequency amplification ahead of such a detector will increase the audio rectified output by more than just the gain of the R.F. amplifier. For example, if the output of the detector is barely audible without preceding R.F. gain, the use of an R.F. amplifier having a gain of only 5 would increase the detector output by approximately 25 times. Thus plate detection as illustrated in Figure 9 should only be used following radio frequency amplifica-

tion.

GRID LEAK AND CONDENSER DETECTOR: The second, and more sensitive, method of obtaining detector action is by use of a grid leak and condenser. It has been shown in the study of grid leak action, that when excitation voltage is applied to the grid electrons are taken by the grid on the positive swings of excitation voltage. Those electrons must flow off through the grid leak which is connected between the grid and the filament, and in so doing make the grid negative with respect to the cathode by the amount of the IR drop across the grid leak. This negative grid bias causes a decrease in the average plate current, and the decrease occurs only when excitation voltage is applied to the grid. When excitation is removed the plate current immediately rises to its normal value.

If this principle is applied to a detector tube and circuit as shown in Figure 10, the results will be as shown in Figure 11. The excitation voltage in the form of a wave train is impressed, through condenser C, between the grid and filament. As soon as the grid is made positive, due to the positive swing of excitation, grid current flows. For maximum sensitivity the grid leak R must be of a sufficiently high resistance that it will allow only a small electron leakage from the grid to the filament. Electrons will therefore accumulate on the grid to a certain extent during the wave train making the average grid voltage negative during the wave train. If this is the case, the average plate current will be decreased for the duration of the wave train, this in turn decreasing the current through the telephone windings and causing a corresponding movement of the diaphragm at the wave train frequency.

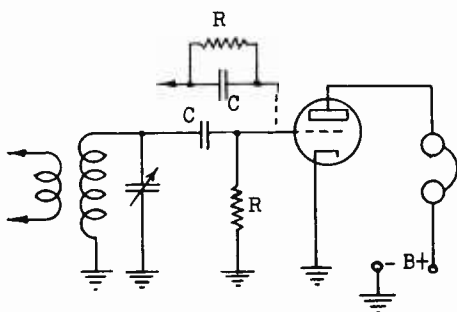

Fig. 10.

method of detection. If a grid leak of sufficient resistance is used to cause

As in the case of the transmitter using grid leak bias, the higher the excitation voltage the greater the bias produced, and the greater the decrease in plate current. Also the higher the resistance of the grid leak, the greater the bias for a given value of excitation. This brings up the real disadvantage of the grid leak and condenser

a fairly large accumulation of electrons on the grid for a weak signal, the detector will be very sensitive to weak signals. However, the grid leak resistance must be sufficiently low to permit *all* the accumulated electrons to leak off between wave trains. If the accumulation is small, as on weak signals, a high value of resistance can permit this leakage. If, however, a very strong signal voltage is impressed upon the grid the large value of resistance may not permit all of the accumulated electrons to leak off between wave trains and the grid can gradually become so far negative as to block the tube.

If the tube is worked at point X on the grid voltage-grid current curve,

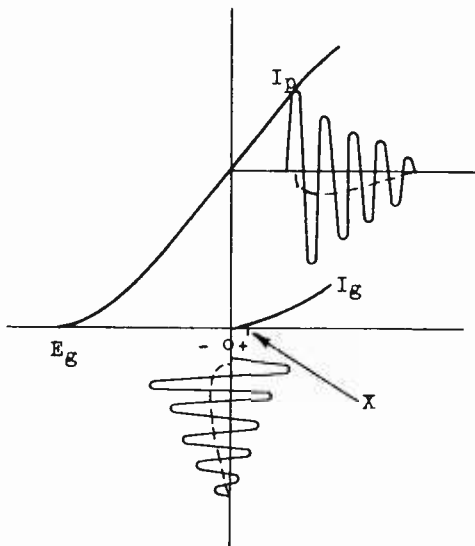

Fig. 11.

Figure 11, a greater increase of grid current will be obtained for a given positive swing of grid voltage than if the grid is normally kept at zero. This is because the increase of grid current beyond the bend at point X is more rapid than the increase for a corresponding positive swing of grid voltage from the zero position. The grid may be operated at this point where a filament type tube with battery power is used by making the grid return to the positive side of the filament instead of to the negative side. The grid is then positive by the voltage of the filament battery minus the voltage drop across the grid leak.

This will make the grid usually a few hundredths of a volt positive with respect to the filament, the actual amount depending upon the type of tube and the resistance of the grid leak. The positive return was ordinarily used in older battery types of broadcast receivers. In A.C. operated receivers the grid return is direct to the cathode.

In oscillating receivers for C.W. telegraphic reception, the negative filament return is preferred because the control of oscillations is somewhat smoother than with the return to the positive side.

The grid leak and condenser method is more commonly used than the grid bias

method for simple radiotelegraph receivers on account of its greater sensitivity. In broadcast work, however, high gain radio frequency and intermediate frequency amplifiers and plate or diode detection are universally used.

It will be noted that for grid leak detection the tube is operated along the straight portion of the $E_g I_p$ characteristic. This is in the region where the greatest amplification is possible. This is a contributing factor in making this type of detector very sensitive. Grid leak detection is also called simply grid detection because the separation of the audio signal component is actually obtained by a variation of the grid bias and that variation is merely amplified in the plate circuit.

Grid bias & auto bias One disadvantage of grid leak detection is the fact that the grid-cathode form a diode unit, the grid leak becoming the diode load resistor, and grid current flows during the signal period. The power necessary to cause the flow of grid current is taken from the preceding R.F. or I.F. circuit, this representing a reflected resistance into the tuned circuit with consequent decrease in selectivity and gain.

POWER AND LINEAR DETECTORS: The operation of a detector is simply that of a rectifier. The ideal detector would be one which would entirely eliminate one-half of the alternations of the radio frequency input, that is, one which would suppress all of the positive alternations or all of the negative alternations, leaving the other half cycles in exactly their original form. The practical detector, other than the diode, will not entirely eliminate the undesired half-cycles. Neither will a detector reproduce the desired alternations in exactly their original form. With certain types of detectors, however, a very high degree of rectification and linear reproduction may be obtained.

Two general types of detection, grid detection and plate detection have been discussed. Grid detection is where the rectification of the modulation envelope is effected in the grid circuit by means of the action of the grid leak and condenser. The form taken by the effective grid voltage is such that the plate current decreases on the modulation peaks and the sensitivity of the detector is a function of the shape of the $E_g I_g$ curve. The operation of such a detector, depending as it does upon the flow of grid current, is subject to the same weaknesses as is an ordinary amplifier under such conditions because, rectification

being obtained in the grid circuit, the tube itself acts very much as a simple amplifier.

The rectifying action of such a detector varies nearly as the square of the signal voltage because it operates into the bend of the $E_g I_g$ curve, and considerable harmonic distortion is introduced in the detector stage. In a radio frequency amplifier the output that can be obtained with a given tube is limited largely by the permissible harmonic content in the output, this limit usually being taken as 5 per cent in broadcast work. The same limitation applies to a detector. Grid

The distortion factor in a square law detector is also a function of the percentage of modulation of the received signal, the distortion factor rising rapidly as the percentage of modulation is increased above about 40 per cent. Up to a few years ago when almost all transmitters were modulated at not much more than 30 per cent, and sensitivity was an important factor in a detector because efficient radio frequency amplifiers had not yet been developed, very little attention was paid to this distortion factor. The distortion with low percentage modulation was not particularly objectionable to the average ear. The development and universal use of high percentage modulation changed this situation. At 100 per cent modulation the harmonic distortion with a sensitive square law detector is very objectionable. At the same time as the development of high percentage modulation came the development of efficient radio frequency amplifiers, so that a high degree of sensitivity in the detector is no longer essential. ~

The second general type of detection, plate detection, is one in which actual rectification is accomplished in the plate circuit, the plate current on the positive alternations of the modulation peaks increasing more than the corresponding decrease on the negative peaks. This is accomplished by biasing the grid so that the tube is operated on the lower *bend* of the $E_g I_p$ curve. (See Figure 9.) This type of detector, using a comparatively low plate voltage and a correspondingly low grid bias voltage in order to obtain a fairly sharp bend in the $E_g I_p$ curve, is less sensitive than the highly sensitive grid detector but has the advantage of being able to handle a stronger signal without objectionable distortion. However this is also a square law detector; the efficiency varies with the amplitude of the signal voltage, and accordingly introduces distortion. The Plate

rectifying action of such a detector varies greatly with the percentage of modulation, so that except for its ability to handle more volume, there is little choice between the two detectors.

The universal use of high percentage modulation by broadcast transmitters demands a detector capable of efficient rectifying action without the introduction of serious distortion. The development of very efficient high gain radio frequency amplifiers and intermediate frequency amplifiers of superheterodynes minimized the need for sensitivity in a detector, but increased the requirement of large signal handling capacity. This led to the development of the so-called "Linear detector." The linear detector is simply what the name implies, a detector in which the output varies directly as the amplitude of the signal voltage.

Linear detection is obtained by working the tube with such plate and bias voltages that the $E_g I_p$ characteristic is essentially linear and the entire lower half of the cycle is cut off without changing the shape of the upper half. This is the condition of ideal detection as previously explained. Such an ideal condition is practical only with an input signal voltage of large amplitude. Two examples of plate detection are shown in Figure 12. (a) shows an example of low plate voltage with a comparatively low negative grid bias. While the positive swings of excitation voltage cause a greater change in plate current than do the negative swings, thus causing an average increase in plate current, the negative half-cycles are by no means entirely suppressed. In the case of a small signal voltage there will be little difference between the plate current variations on the two alternations. Due to the bend in the $E_g I_p$ curve detector action is obtained, but it is easy to see that this action is by no means linear; the efficiency of detection varies greatly with the amplitude of the input modulated signal voltage.

In Figure 12(b) the plate voltage and grid bias voltage are both high. The high plate voltage results in an almost straight $E_g I_p$ characteristic. With the tube biased almost to the cut-off point and large excitation voltage impressed on the grid, the ideal condition is approached. The plate current is zero for practically the entire negative grid voltage swing while on the positive swing, due to the long straight portion of the curve, the plate current varies almost

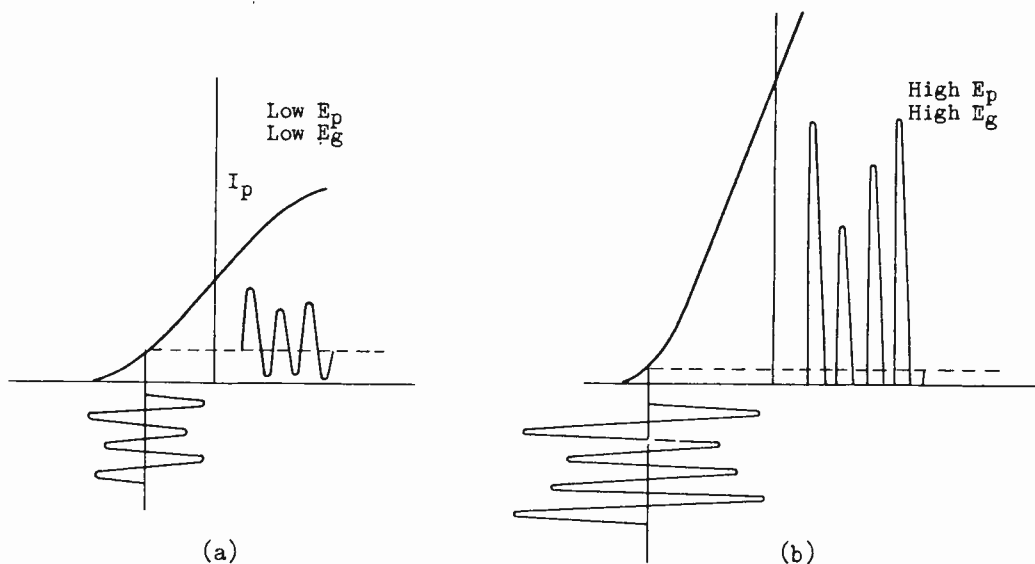

Fig. 12.

directly as the grid voltage. Thus with a signal amplitude sufficiently great to make the duration of plate current during the negative swings negligible compared to the time of the positive swings, the rectification is almost complete and the output is essentially a true reproduction of the input modulation envelope.

A consideration of Figure 12(b) will show that even with high percentage of modulation on comparatively strong signals there will be little distortion because the entire negative side of the modulation envelope is suppressed until the percentage of modulation becomes very high, and the positive side is reproduced faithfully because of the linearity of the characteristic curve. This is not the case in 12(a). The linear detector is really nothing more than a Class B amplifier with the plate circuit so arranged as to suppress the carrier frequency while accepting and passing on to the next tube the modulation frequency component.

The linear detector as shown in 12(b) is not at all sensitive to very weak signals. This is of little importance, however, because the use of a high gain R.F. or I.F. amplifier permits the required signal voltage to be impressed upon the grid of the detector tube and fidelity of reproduction is the principal factor to be considered. It should not be thought that this detector is not an efficient amplifier. It is, as is shown by the steepness of the $E_g I_p$ curve. Either, a three or four element tube can be used and excellent detector efficiency and

output obtained in either case.

In view of the fact that the tube is biased almost to cut-off, no grid current flows during any part of the input cycle. Thus there is no loss of selectivity in the driving R.F. or I.F. circuit as with grid leak or diode detection.

The development of high gain amplifiers and linear detectors led to the "Power detector." The power detector as ordinarily used is simply a linear detector operated with the proper voltages to permit an output voltage sufficient to fully excite the grid of the final audio power amplifier tube to obtain full output from the receiver. Again either the three or four element tube may be used as a detector, although, due to its much higher amplification factor the tetrode or pentode is to be preferred. The alternative of course, is to use a higher gain R.F. or I.F. amplifier. Where the maximum of selectivity is required and economical construction is not particularly important, an additional stage of I.F. amplification followed by a triode detector is usually employed. Where space and cost are of major importance, as in the design of a "midget" receiver, the tetrode or pentode detector proves highly desirable, feeding directly into a single stage of audio amplification using a power pentode. Here the combination may be first detector, two stages of I.F. amplification, a screen grid power detector, followed by a power pentode, the latter being used because of its high gain.

The true power detector is one in which sufficient power output is developed to drive the reproducer direct without the use of audio frequency amplification. Such a detector is very seldom used in practice.

When speaking of a linear detector it is meant that the audio frequency variations in the output are directly proportional to the audio frequency component from the transmitter, assuming of course, that no distortion has been introduced by the R.F. and I.F. amplifiers. Examining a tube $E_g I_p$ curve, it will be seen that in order to obtain linear response two principal factors must be taken into consideration, assuming that the plate and grid bias voltages are correct. These factors are the percentage of modulation and the amplitude of the carrier voltage. With a very low carrier voltage, regardless of the percentage of modulation, the portion of the negative half-cycle during which current flows will become too great a proportion of the total time, and the output will approach

that of the square law detector. On the other hand, if the amplitude of the carrier voltage is too great, the grid will swing highly positive on the modulation peaks, thus drawing grid current and decreasing both the selectivity and sensitivity of the detector circuit and causing corresponding distortion. There is some range of carrier amplitude in which the most nearly linear output from the detector will be obtained. This should be determined and maintained with adequate automatic volume control.

The percentage of modulation is important. With low percentage of modulation and a comparatively large carrier amplitude, the variations of the audio frequency component on the positive half-cycles can be kept entirely within the linear portion of the $E_g I_p$ curve and practically no distortion will be introduced. As the modulation exceeds a certain percentage, the audio frequency component begins to swing into the bend of the curve, and some distortion is introduced. With properly proportioned plate, grid and carrier voltages, the amount of distortion can be held below an objectionable value even approaching the peaks of 100 per cent modulation.

Another factor which must be taken into consideration is the plate load circuit. The output obtained from any tube is a function of the plate load impedance. If that impedance varies over wide limits with the modulation frequency, the output of the tube will also vary with frequency. From the point of view of linear detection, a resistance plate load circuit is to be preferred and some circuits employ resistance coupling between the detector and the first audio amplifier tube, particularly when a screen grid detector is used where, for efficient operation, the output impedance should be very high. If reactance or transformer coupling is used between the detector and audio amplifier, the same conditions apply as exist for undistorted output from an audio frequency amplifier tube; that is, L must be sufficiently great to keep the inductive reactance high as compared with the tube plate-filament resistance at the lowest audio frequencies. Since the plate-filament resistance of a tube such as the 6J7 exceeds 1.5 megohms, it is not practical to obtain anywhere near sufficient impedance by means of inductance to get really efficient amplification from the screen-grid detector at the lower audio frequencies.

Where resistance coupling is used with a tube such as the 6J7 or 6C6, the

plate load resistance may be from .25 megohm to 1 megohm, depending mostly upon the combination of tube voltages used.

With a comparatively large plate load resistance the tube will operate much more efficiently and the added output will compensate for the lack of voltage step-up that could be obtained with transformer coupling. With resistance coupling the output impedance will be very nearly the same at all audio frequencies, providing a sufficiently large coupling condenser is used. A careful study of the operating characteristics of the 6J7 and 6C6 as listed in the manufacturer's tube manual will be helpful.

GRID LEAK DETECTION OF LARGE SIGNAL VOLTAGES: It has been shown that grid leak rectification is accomplished by means of a charge on the blocking condenser which accumulates during the instants at which the grid is actually positive and grid current flows, this charge gradually leaking off through the grid leak. For most efficient detector action the grid is normally operated at the bend of the $E_g I_{gp}$ curve. Under this condition the greatest sensitivity will be obtained by the use of a comparatively large grid condenser and a comparatively large grid leak resistance. For the detection of small signals where sensitivity is the important factor, a commonly used combination is a condenser of 250 $\mu\mu\text{F}$ and a grid leak of 2 megohms. With such a combination, however, the distortion will be excessive on a large signal voltage, increasing rapidly with both the carrier amplitude and modulation percentage. This is due to the fact that the discharge of the condenser through the grid leak cannot follow the modulation envelope of the signal.

It has been experimentally shown that large signals at high modulation percentage may be handled without excessive distortion by means of grid leak and condenser detection if a suitable combination of grid leak and condenser is used. It has been found that the distortion will be small under the condition as expressed in the following relation:

$$\frac{X}{R} > \frac{m}{\sqrt{1 - m^2}}$$

where X equals the reactance of the effective grid condenser capacity at the modulation frequency in question, R equals the grid leak resistance, m equals the percentage of modulation expressed as a decimal. The effective grid condenser

capacity is equal to the capacity of the grid condenser plus the effective input capacity of the tube. Thus so long as the value of X/R is equal to or greater than $m/\sqrt{1-m^2}$ the distortion will not be excessive with any signal voltage within the operating limits of the tube.

An examination of this relation brings out several points. As the degree of modulation is increased the value of the relation X/R must be increased. To avoid distortion on the modulation peaks the capacity of the grid condenser and the resistance of the grid leak must be computed for a high percentage of modulation. Of course the factor $m/\sqrt{1-m^2}$ is equal to infinity at 100 per cent modulation so some practical limit must be selected. At 90 per cent modulation the distortion will become objectionable at a value of X/R less than 2. If the value of X/R is not less than 4, modulation percentages up to more than 95 per cent may be handled with a moderately strong signal. }}}

It would seem that, in order to keep the value of X high a very small grid condenser would be desirable. However, as has been shown in earlier lessons, the excitation voltage divides up between the grid condenser and the grid input capacity, and efficient operation of the circuit demands a grid condenser the capacity of which is somewhat larger than that of the grid-filament tube capacity. With ordinary receiving tubes the grid condenser should be between 50 and 100 $\mu\mu\text{F}$ with grid leak resistance of from .2 to .5 megohm. C+R
}}}
large

With a combination of .25 megohm grid leak and 100 $\mu\mu\text{F}$ condenser, the permissible percentage of modulation, which decreases with frequency due to the decreasing value of X , drops to above 90 per cent at 2000 cycles and to about 80 per cent at 5000 cycles. However, since most of the power in speech and music (and consequently the modulation peaks) will be at frequencies below 1000 cycles, the combination mentioned will, in actual practice, show no noticeable frequency discrimination.

It is essential that the grid leak be of such value that the rate of discharge of the condenser through the grid leak is at least as rapid as the variations in the modulation envelope. So long as this condition is maintained distortion will not be introduced to any great extent in this part of the circuit. It is also essential that the plate voltage be made sufficiently high to provide a long straight $E_g I_p$ characteristic in order that the plate current }}

variations may take place within the limits of the straight portion of the characteristic curve. If the plate current variations are forced beyond those limits plate rectification will take place, the combination of plate and grid rectification resulting in bad distortion.

Max Sig

The maximum carrier voltage that the grid leak power detector will handle is slightly less than one-half the permissible input voltage of the same tube operated as an amplifier with the same plate voltage. The maximum undistorted output of such a detector is approximately one-third the output voltage of a corresponding amplifier. Grid leak power detection is somewhat more sensitive than plate detection but the grid leak power detector is not nearly as sensitive as regular small signal grid leak detection. This latter fact is no disadvantage, however, because like the plate power detector, it will only be used when there is sufficient R.F. and I.F. amplification to assure an adequate input signal amplitude.

Neutral

Where a detector output sufficient to excite the power amplifier stage, eliminating the first audio stage, is desired, a screen grid detector is often used. By the proper combination of voltages and impedances, advantage can be taken of the high amplification factor of the screen grid tube. Used as a power detector the tube must be capable of handling radio frequency input voltages in the order of a volt or slightly higher without overloading, and it must be capable of supplying peak voltage of 15 to 20 volts to the grid of a pentode power tube. Plate rectification will fulfill both of these requirements provided that a suitable detector output circuit is used. Grid leak detection is less satisfactory for this type of detector, because, first, it will not as easily handle the large signal voltages and, second, it will add damping to the tuned input circuit and decrease the selectivity.

Since a very high plate load impedance is desired without frequency discrimination, resistance coupling to the power stage is most satisfactory. A combination of 1 megohm plate resistance, 1 megohm grid resistance, and coupling capacity of .01 microfarad will have a combined impedance sufficient to give very satisfactory results with a 6J7 tube followed by a power pentode such as the 6F6.

The negative bias for plate detection will ordinarily be supplied by a

cathode resistor, the value of which will depend on the other voltages used. With a tetrode or pentode the space current will be very largely a function of the screen voltage. Thus to calculate the proper value of cathode resistance it is necessary to have available tube characteristic curves for the range of E_g and E_p desired but plotted for the screen voltage to be used. If such data are not available the proper circuit constants may be determined experimentally or the proper combination of voltages, resistances and capacities may be found in the manufacturer's tube manual. The desired operating condition is as shown in Figure 12(b).

THE DIODE DETECTOR: The development of better amplifier circuits for use at radio frequencies and better reproducers in the audio frequency end of the receiver and the increased use of automatic gain control of the radio frequency section paved the way for the use of the diode detector. It was pointed out in the discussion of the plate detector that higher signal inputs to this type of detector produced an output signal with less distortion than possible otherwise. The diode detector has several characteristics which make its use desirable. The most important of these are (1) the diode is essentially linear at high inputs thus producing minimum distortion (2) it requires no bias for operation (3) the ratio of signal to hum originating in the detector is greatly increased (4) it produces a D.C. output component which is proportional to the strength of the signal input only making it a nearly perfect device for automatic gain control (this use will be discussed in a later lesson) (5) modulation products resulting from strong unwanted signals are considerably minimized.

The action of the diode detector is strikingly similar to the operation of the "grid-leak condenser" mode of detection. The greatest difference is the ability of the diode to handle large inputs in contrast to the triode (or tetrode or pentode) used as a "grid-leak condenser" detector. It must be understood that in the diode detector, only two elements or their equivalent are considered. One is the anode, the other the cathode. A diode is a two element tube (or its equivalent) as far as the diode section is concerned. If a triode is to be used as a diode, only the grid and cathode will be employed, with the plate grounded to the cathode in which condition it will shield the active elements, or the plate may be tied to the grid with both the grid and plate

then acting as a single element. It has been demonstrated experimentally that better operation is obtained with the plate connected to the cathode. The use of a triode as a diode is not now as common as formerly since several diode tube types are now available. A diode is actually a unilateral conductor because space current can flow only from cathode to plate and only when the plate is positive with respect to the cathode.

The diode rectifier in itself offers no amplification; for satisfactory operation a comparatively large input signal is necessary. Both of these factors are relatively unimportant in practice. The diode rectifier may be followed by a stage of resistance coupled audio amplification employing either a triode or a pentode; in fact such a stage of amplification may be included within the same tube as the diode elements as in the duplex-diode triode and the duplex-diode pentode, the term "duplex" simply indicating that two diode units are enclosed within the bulb. The requirement of fairly large input signal voltage is satisfied in practically all modern receivers. A very large proportion of all modern receivers are superheterodynes with large I.F. and R.F. gain ahead of the second detector.

The twin diode Type 6H6 is a small metal tube containing two diode units, either of which, or both, may be used as a diode detector. Figure 13 shows the external appearance and dimensions of the 6H6; Figure 14 shows the arrangement of elements; Figure 15 shows the average characteristics of the tube. Figure 16 shows the diode detector circuit in its most simple form.

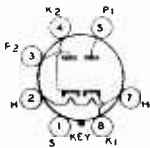

Fig. 14

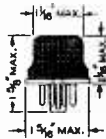

Fig. 13

An examination of Figure 16 indicates a striking similarity to a power rectifier circuit. Indeed, the operation is similar with this difference:

In the case of the power rectifier, the D.C. output is the only output ordi-

narly wanted, the A.C. components being filtered out but in the use of the diode as a detector or demodulator, one may require the use of both the A.C. modulation component and the D.C. component or either singly depending on whether the diode is employed for demodulation or AVC voltage rectification or both simultaneously. In many circuits, the cathode of the diode is grounded.

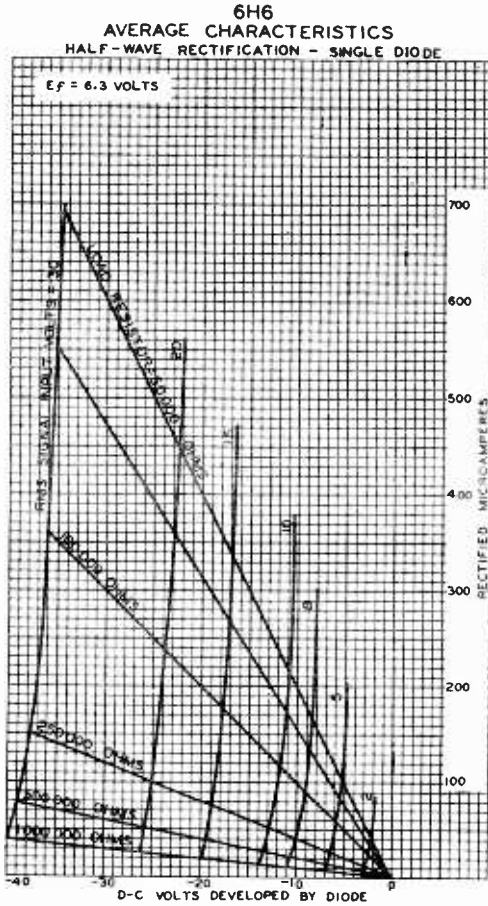

Fig. 15.

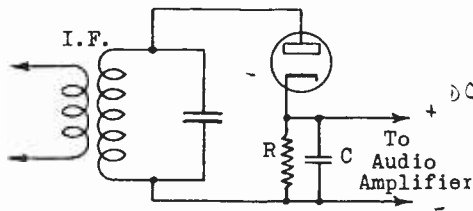

Fig. 16.

The modulation appears as the envelope determining the peaks of the R.F. waves. The diode rectifies this A.C. voltage which results in a D.C. component and a modulation component appearing across the load and R.F. components which also

The cathode end of the circuit is positive making the other end of the load resistor negative, with regard to the D.C. component of rectified output. Since this component is dependent on the carrier strength only it becomes an ideal source of automatic gain or volume control for the radio frequency stages of the receiver, which includes the preselection and intermediate stages. The use of the diode to supply the AVC voltage will be discussed in a later lesson.

The A.C. modulation component of the R.F. voltage applied to the diode is the intelligence bearing portion. This voltage also appears across the load resistor R. The condenser C is chosen such that it will by-pass the R.F. component (i.e., filter it from the output by short-circuiting the load resistor to this frequency) but look like an open circuit to the lower frequencies of the modulation component. The R.F. wave applied to the diode and load resistance is shown in Figure 17.

appear across the load. The load is complex, i.e., a resistance and a reactance in parallel, and the nature of this complex load is a function of the values of R and C chosen and also the frequency applied. The condenser will effectively short out the R.F. components but will appear as a high value of reactance to the A.F. modulation components since these are much lower in frequency. Consequently, the D.C. voltage of rectification and the A.F. modulation voltage components will appear across the condenser and hence across the load resistance. The D.C. voltage will steadily bias the anode negative and this affect will be to produce a shift in the axis of symmetry for the applied R.F. voltage to the diode and load, resulting in a condition shown in Figure 18. The voltage appearing between the anode and cathode will be seen to be the R.F. voltage less the value of the voltage appearing across the load resistance. During the time that the plate is positive, pulses of current will flow, the duration of these pulses being determined by the circuit characteristics. When these values are properly chosen the voltage developed across the load resistance will be just slightly less than the applied R.F. voltage. This means a high efficiency of detection and in well engineered diodes will run from 85 to 95 per cent.

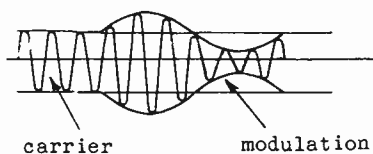

Fig. 17.

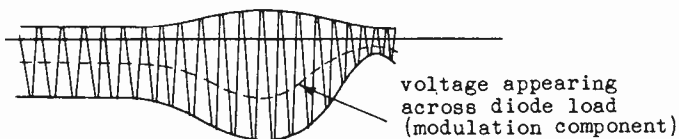

Fig. 18.

The simple circuit of Figure 16 is used in a number of receivers. More elaborate circuits are shown in Figures 19 and 20. These circuits include filters for the purpose of removing as far as possible the effects of R.F. voltage on the grid of the first audio amplifier. In Figure 19, the network C_1 and R_1 comprise the filter circuit while C_2 , and R_2 comprise the useful load circuit. In Figure 20, there has been added an AVC filter C_3 , R_3 ; and the condenser C_3 of Figure 19 is now C_4 . The use of the filter is desirable but reduces the useful rectified voltage by the ratio of R_1/R_1+R_2 for the circuit of Figure 19, and similarly in other circuits. The usual value for R_1 is approximately 50,000 ohms. The values of C_1 and C_2 will depend on the intermediate frequency.

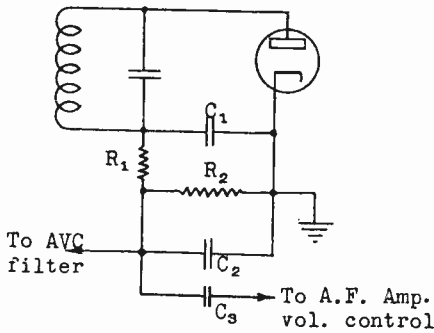

Fig. 19.

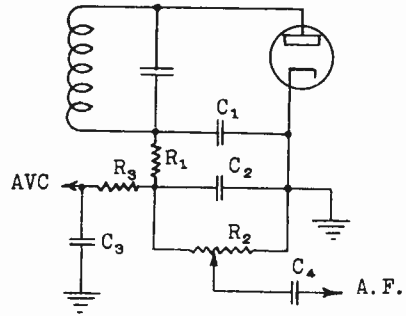

Fig. 20.

Occasionally C_2 is omitted entirely.

In all diode detector circuits, the load is complex. (Compare Figures 16, 19 and 20.) It will be observed that there is always a condenser shunting a resistor. This means that the same load characteristic will not be presented at all frequencies. Thus the load will discriminate against the higher frequencies. This means that distortion will be introduced at high modulation frequencies. Also, it can be shown that distortion due to the modulation factor of the radio frequency wave will also be introduced. This is largely determined by the time rate of discharge of the condenser, resistor combination. Trouble of this sort may be minimized by satisfying the following relation, due to Terman.

$$\frac{X}{R} > \frac{m}{\sqrt{1 - m^2}} \quad (\geq \text{ is read equal to or greater than})$$

where X = reactance of the shunting condenser at the frequency in question, R = load resistance and m = the modulation factor. It will be observed that the above expression becomes indeterminate when $m = 1$. However, if X/R is equal to 2 or 3, the distortion will not be objectionable with m as large as .95 or so.

Distortion is also introduced when small signals are impressed on the diode because of curvature of the diode characteristic. This source of distortion may be minimized by the use of high signal inputs and by the use of large load resistors as compared with the diode resistance.

The value of the condenser connected across the load resistor is so chosen that its impedance at the intermediate frequency is low compared to the plate

to cathode resistance of the diode. With modern diodes available, the value of the condenser will be such that its reactance is in the neighborhood of 2000 ohms. This value dictates a condenser of about 450 $\mu\mu\text{F}$ for an intermediate frequency of 175 KC/s and about 170 $\mu\mu\text{F}$ for an intermediate frequency of 465 KC/s. Values for this capacity will vary considerably due to designer's individual requirements and may run as small as 50 $\mu\mu\text{F}$ in some receivers.

The value of the load resistor is governed by the R.F. input voltage, the diode characteristics and the desired D.C. output voltage, if the detector is also to be used to develop the AVC voltage. The rectification characteristics of the various diodes are furnished by the manufacturer. Figure 15 illustrates the characteristics of one section of a 6H6. When the RMS value of the R.F. input has been decided upon the load line may be drawn on the curves. For example, suppose that the RMS input is set at 30 volts maximum and that 35 volts, D.C., for AVC are to be developed. Determine the intersection of the D.C. volts developed by the diode and the RMS signal input volts = 30. The rectified current is taken as 550 microamperes. The load line is then drawn between the point of intersection and the 0 - 0 point. (See Figure 16.) The value of the load resistor is determined by evaluating the D.C. volts developed by the rectified current at any point. Take the point for D.C. volts developed = 35 and rectified current = 550 microamperes. The value of resistance is then $35 / (550 \times 10^{-6}) = 63,500$ ohms, very nearly. This is the proper value of load resistance to employ. The values of D.C. output voltage may be picked off this line together with the R.F. input voltage to produce it, and the data plotted to show the AVC control characteristics, if the diode is also to furnish AVC voltage.

The values taken above are for the purposes of illustration where the curves are fairly wide apart and more easily read. For detection or AVC action, higher values of load resistor are desirable since these result in higher detection efficiency and less loading of the input circuit. In general, the load resistor will normally run about 250,000 ohms.

If only one of the diode plates (in case there are two) is to be used, the other plate should be grounded. In modern receivers, it is usual to employ one diode as the detector, the other as the AVC voltage generator. In this way, it

is more easily possible for each diode to perform its purpose efficiently.

The audio voltage from the diode demodulator may be determined from a knowledge of the voltage available to the demodulator from the intermediate frequency amplifier. If the RMS voltage applied to the diode is 30 volts and is modulated 50 per cent, the RMS value of the audio modulation component is $30 \times .5 = 15$ volts. If the signal is modulated 100 per cent, the RMS value of the audio modulation component is 30 volts. This may be stated as

$$E_{af} = E_{rms} \times m$$

where E_{af} = the RMS value of the audio modulation component

E_{rms} = the RMS carrier value of the R.F. signal applied to the diode

m = the modulation factor (this varies from 0 to 1.0)

It must be remembered that the percentage modulation is not under control of the receiver designer. He makes his design on the assumption that the transmitter will be modulated from 0 to 100 per cent as is usual in modern transmitting technique. His selection of radio frequency input voltage to the diode is based on the requirements of the audio channel in the receiver. The relations between demodulator and audio channel in the receiver will be considered in later lessons.

Input voltages to the diode less than about .5 volts RMS should be avoided because of curvature of the characteristic. For inputs below this value, square law detection results with consequent distortion of the higher modulation percentages.

Where a duplex-diode triode or a duplex-diode pentode is used, the rectified output is resistance coupled to the control grid of the triode or pentode section, usually through a potentiometer for manual volume control. The actual circuit is the same as if a separate amplifier tube had been used.

Figure 21 shows a portion of a receiver circuit in which a duplex-diode pentode Type 6B8 is used as diode detector, A.V.C., and 1st audio amplifier to drive a beam power amplifier. At the upper left the I.F. transformer connects to the two diode plates (in parallel), the lower end of the I.F. transformer connecting to the diode load resistors R_1 and R_2 across which is C_1 , a 100 μF filter condenser. ($R_1R_2C_1$ represents the RC combination of Figure 16.) R_2 is the volume control potentiometer. The audio voltage developed between the

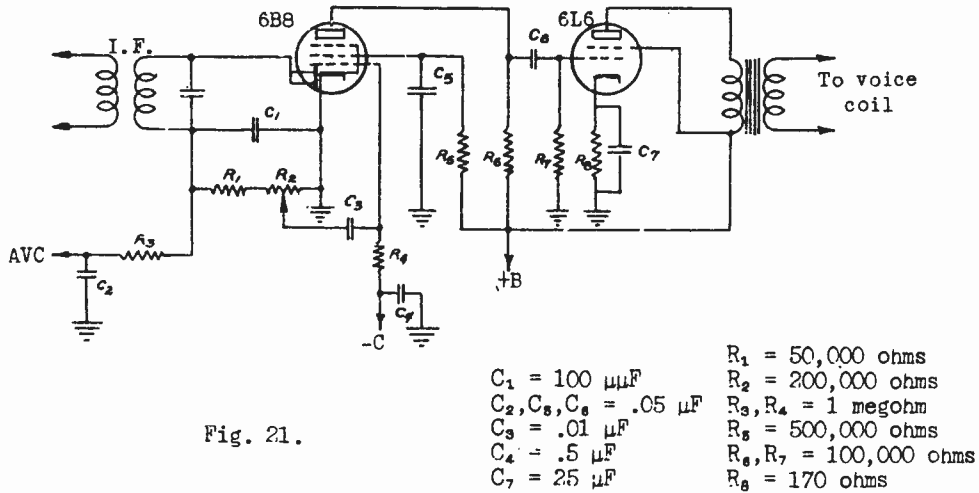

potentiometer contact and cathode is applied by means of C_3 as excitation to the control grid of the pentode section of the 6B8. The negative bias for this grid is supplied through the isolating filter R_4C_4 .

The output of the 6B8 pentode is resistance capacity coupled ($R_6C_6R_7$) to the control grid of the 6L6 beam power amplifier, the Class A bias of which is supplied by cathode resistor and condenser R_8C_7 .

The diode detector also supplies negative A.V.C. voltage to the grids of the preceding tubes by way of R_3C_2 , this combination serving as a filter to remove the audio frequency component so that an average negative bias, determined by the average I.F. signal level is applied to the R.F. and I.F. amplifier tubes.

INFINITE IMPEDANCE DETECTOR: It has been observed that a disadvantage of the diode detector is the loading of the tuned output circuit of the last intermediate frequency transformer. A circuit to avoid this difficulty is shown in Figure 22. This type of detector is known as the "Infinite Impedance" detector and, besides eliminating the loading on the driving circuit, produces less distortion in the demodulated signal because no grid current is drawn. It has the disadvantage that no AVC voltage is available from this type of detection.

In the plate detector, it will be recalled that the load is placed in the

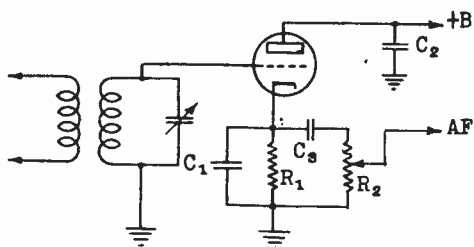

Fig. 22.

circuit from plate to +B and the A.C. component is coupled to the first A.F. amplifier by a large condenser. The bias in this case is furnished by a cathode resistor. In the "Infinite Impedance" detector, the loading resistor is placed in the cathode circuit where it performs the dual role

of load and bias resistor. This is possible because the plate current flows through this resistance. The D.C. component drop will supply the necessary bias, adjusting itself to various carrier levels automatically. The demodulated component is taken off the cathode end of the cathode resistor.

The plate of the tube is by-passed to ground by C_2 which may be from .1 to .01 μf . Its value is not critical. This means that the plate is at ground potential as far as both audio and radio frequency components are concerned. C_2 should be large enough to satisfy this requirement, i.e., its reactance should be small for the lowest frequency. However, these components must flow in the cathode circuit. The radio frequency components are not desirable since they will load the A.F. amplifier following the detector. Therefore, they are by-passed by C_1 . This must have a reasonably low reactance at the radio frequencies but a large reactance to the audio frequencies. Values in the order of 100 μmf or so will be satisfactory for the intermediate frequencies used in modern receivers. C_3 is likewise made to have a low reactance to the lowest A.F. signal, .05 μf should be satisfactory for most applications. R_1 is not extremely critical but should be relatively high. Values from 100,000 to 150,000 ohms are used. R_2 is an ordinary volume-control potentiometer of 250,000 ohms or so. If R.F. appears on the grid of the first A.F. tube, R_1 may be split into two sections of say 50,000 and 100,000 ohms with the lead to the volume-control taken off at the junction. Medium μ triodes give the best results since the higher impedance tubes introduce modulation distortion. A 6C5 tube is a good choice.

In operation, the bias developed across R_1 is sufficiently large that input signals from the last I.F. transformer as large as 25 volts or more are handled

without causing grid current flow. This is an advantage since even signals with a high percentage modulation may be handled with better fidelity than in the case of a diode. The input impedance is almost a pure reactance so this may be advantageously employed in tuning the output of the last I.F. transformer.

Likewise the circuit Q is higher than with resistive loading as for the diode. Modifications of the circuit are possible for supplying AVC voltage but this must be done with additional circuits. Separate AVC circuits, such as might be used, are explained elsewhere.

MIXER CIRCUITS FOR SUPERHETERODYNE RECEIVERS: Probably the most widely-used receiver circuit is the invention of Major Edwin Armstrong and is known as the superheterodyne. Briefly, in this circuit, the signal received from the antenna circuit is "mixed" with a locally generated signal and converted to a third frequency called the intermediate frequency, amplified at this frequency and then "detected" in detector circuits as previously discussed in this lesson. The theory and advantages of the superheterodyne are discussed in a later lesson dealing with receiver design. Since the "mixer" stage of a superheterodyne receiver is frequently called the "first detector" stage, these special circuits will be discussed in this lesson. The detection principle is that called "heterodyne" detection considered earlier in this lesson.

The frequency conversion system or "mixer" stage is the heart of the modern superheterodyne receiver. In this stage, a voltage of frequency f_1 is combined in such a way with a voltage of frequency f_2 to produce other frequencies. It can be shown that new frequencies will appear in the output of the mixer tube, the frequency of importance to the receiver designer is the difference of the frequencies f_1 and f_2 and is called the Intermediate Frequency. As an example, if a received signal has a frequency of 1000 KC/s and is combined with a frequency of 1465 KC/s, the difference frequency is 465 KC/s. In the superheterodyne receiver, this new frequency is always at a radio frequency, the choice of this frequency being determined by factors to be considered later. It is with the problem of mixer stages that this section of this lesson will deal.

The tube employed in the mixer stage may be either a tube designed especially for the purpose of mixing or it may be a tube not originally designed for this task but adapted to it in the proper way. The important features which

should be considered in the choice of a mixer tube, particularly if this tube is to be used in an all-wave receiver, are (1) a high transconductance, both for the mixer and oscillator tube sections (2) minimum reaction between oscillator and mixer tube section (3) low tube noise (4) possibility of circuit simplicity to minimize switching problems (5) a high degree of oscillator stability. Some of these may be difficult to achieve in the higher frequency bands.

Figure 23 is a block diagram illustrating the circuit line-up for the superheterodyne receiver. Note that the locally generated high frequency oscillation, differing from the received signal by the intermediate frequency, is combined in the mixer stage and the difference frequency only is further amplified by the intermediate frequency amplifier.

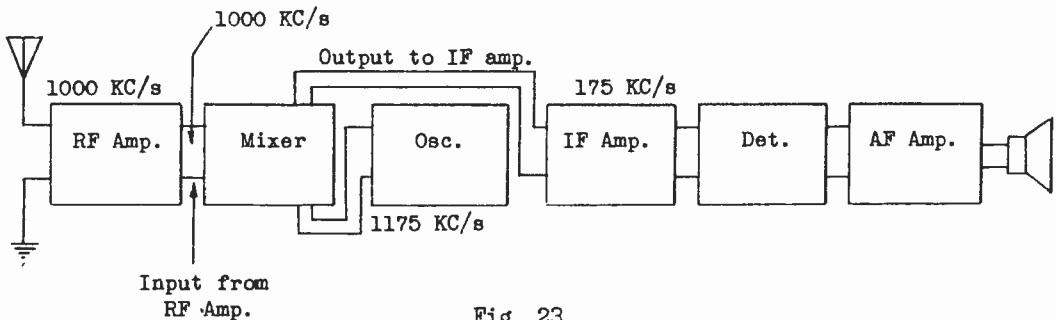

The natural question now arising is "Where in the mixer circuit is the signal voltage introduced and where is the oscillator voltage introduced?" The signal frequency voltage is normally fed directly from a tuned circuit to the *control grid* of the mixer tube. This grid is sometimes also called the *signal grid*. If the tube is an R.F. pentode adapted for mixer work, the number one grid or control grid is used. If it is a special tube for mixer work, such as a pentagrid converter tube, the proper grid is also called the control grid even though it may not occupy geometrically the same position in the pentagrid converter as in the R.F. pentode. The point of introduction of the locally generated oscillator voltage cannot be answered as directly as the following mixer circuits will show.

In the earlier superheterodynes, no special mixer tubes were available, so R.F. pentodes or tetrodes were adapted for this purpose. The cathode circuit of the mixer tube presented an easy and reliable point for injection of the

oscillator voltage. This circuit is illustrated in Figure 24. The electron

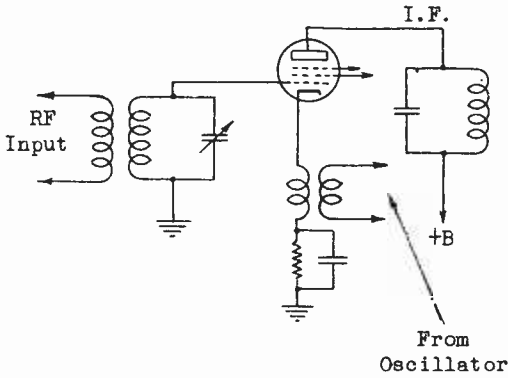

Fig. 24.

stream emitted from the cathode is thus seen to be varying initially at the oscillator frequency. This electron stream is then modulated by the signal which is imposed on the control grid. This is the least difficult method to obtain the voltage for complete modulation of the stream and has been widely employed for superheterodynes operating on the broadcast band only. It may be used

in any circuit where the reactance of the coupling coil does not change over wide limits. It also complicates the switching problem when shifting from band to band and is little used in recent models.

The signal from the oscillator may be injected in the control grid circuit as shown in Figure 25. This method has been widely employed since it is simple and direct. Earlier models of several excellent high frequency superheterodynes used it.

Good

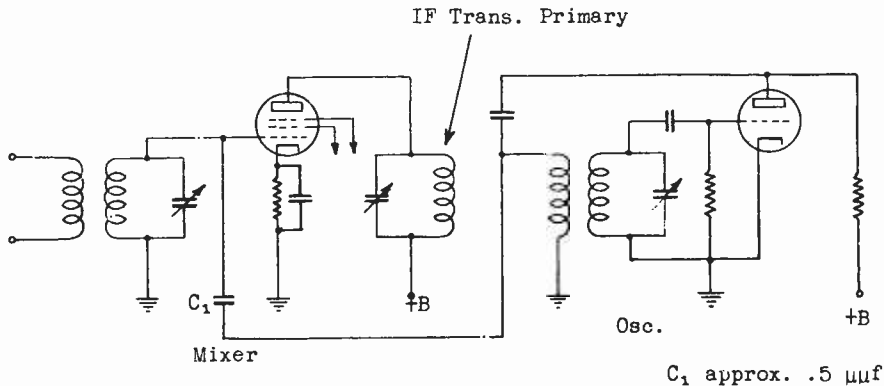

Fig. 25.

The oscillator voltage may be introduced in the screen grid circuit as shown in Figure 26. This method is open to objection, due to the large voltage required. This is the method of injecting the oscillator voltage from a modified "electron-coupled" oscillator in contrast to the tuned-grid oscillator of

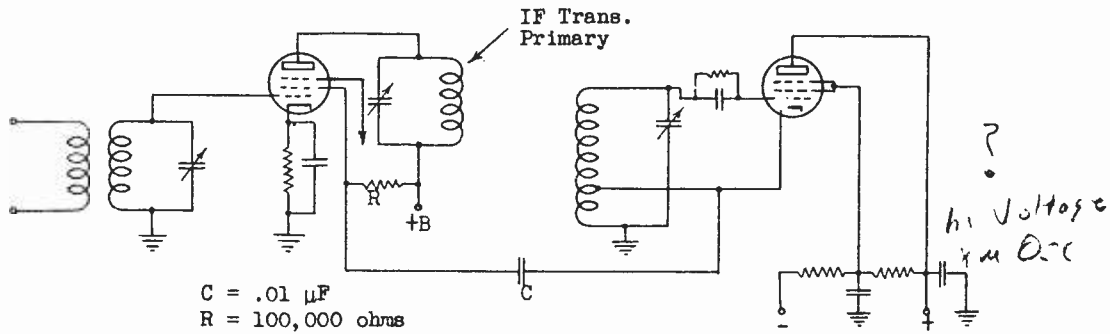

Fig. 26.

Figure 25.

Modulation in the suppressor grid circuit of an R.F. pentode is sometimes used. This scheme is shown in Figure 27. The oscillator voltage required is moderately large but the power requirement is negligible. The plate resistance is rather low however which results in a lower conversion gain.

This lowering of the plate resistance is inherent in a pentode tube where the suppressor grid is biased negatively. This negative bias causes a relatively dense space charge to form between the accelerator or screen grid and the suppressor, thus producing the effect of a virtual cathode in this space. The tube then becomes effectively a triode with the space charge acting as the cathode, the suppressor as the negative control grid and the plate as the regular triode plate. While the plate resistance of this virtual triode is in the order of 100,000 ohms or so, it will be seen that this plate resistance is considerably less than that for the pentode which is in the order of a megohm. Thus, it will be seen that the gain is materially lowered by this arrangement.

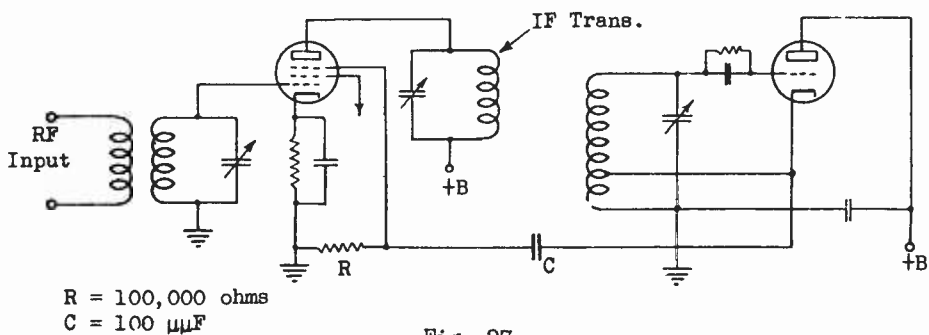

Fig. 27.

The circuits considered, with few exceptions, require the use of a separate oscillator tube. This is axiomatic where all-wave operation is employed. About 1932, there was developed by the RCA Manufacturing Co. a new type of tube which embodied in the same envelope the mixer and oscillator elements. This results in a saving of an extra tube and socket. This tube type is known as the pentagrid converter. Among its advantages in addition to those mentioned are high conversion transconductance, and minimized switching requirements.

A typical application of a pentagrid converter is illustrated in Figure 28. The tube has a heater, cathode, five grids and a plate. The first grid is called the oscillator grid, the second the anode grid, grids three and five are tied together to form a screen grid and grid four is the signal or control grid. The grids are numbered 1, 2, etc. from the cathode toward the plate.

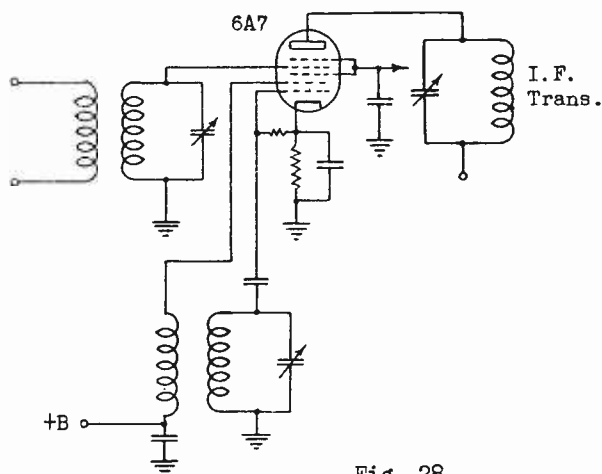

Fig. 28.

(Most modern all-wave receivers employ three bands, the first will be called the broadcast band, the second extending from approximately 1700 KC/s to 6000 KC/s will be termed the medium frequency band, and the third covering frequencies from approximately 6000 KC/s to 18,000 KC/s will be called the high frequency band.) The coupling may be due to a common coupling impedance, such as a condenser C_1 as illustrated in Figure 25 or a coupling known as "space charge" coupling. Either or both may be present but, in modern circuits, the latter is normally the only one present. This coupling effect may be felt by a "pulling" effect of the signal frequency on the oscillator, that is, a strong signal at

In any of the circuits discussed, difficulty in operation may be experienced as the operating frequency is increased due to coupling between the oscillator and the signal circuits. This coupling effect may be negligible at the broadcast and medium high frequencies but may result in inferior operation in the high frequency band.

the signal grid may pull the oscillator into step with it and no beat will result, hence no I.F. signal in the output of the mixer.

Space charge coupling is present to a greater or lesser degree in all mixer tubes, regardless of type. The more modern mixers minimize it but none eliminate it completely. It is due to the motion of the space charge, varying at the oscillator frequency, in the vicinity of the signal grid. It is a well known fact that a charge in motion in the vicinity of a conductor will cause a current to flow in the conductor, even though there is no actual flow of electrons from the charge to the conductor. In a vacuum tube, the movement of electrons in the vicinity of a grid will cause a displacement current to flow in that grid, even though the grid may be negative and thus preventing an actual current flow. This charging or displacement current is proportional to the time rate of change of the potential gradient at the grid.

In a converter tube, if the space charge is varying at the oscillator frequency, the displacement current will flow at the oscillator frequency. Now, if the oscillator frequency differs from the frequency to which the input circuit is tuned, i.e., the signal frequency, by only a small percentage, the signal circuit will offer a moderately high impedance to that frequency, hence a voltage of considerable magnitude at oscillator frequency will be developed across that circuit.

For example, consider an input circuit in an all-wave receiver tuned to a signal frequency of 12 MC/s. The parallel impedance of the tuned circuit (remember that the grid circuit looks at the input circuit as a parallel circuit) may be expressed as QX_c where Q will run around 100 at this frequency and X_c will approximate 150 ohms. Thus the input impedance will be approximately 15,000 ohms at 12 MC/s. With an I.F. of 465 KC/s, the usual value for modern all-wave receivers, the oscillator frequency will be 12.465 MC/s, so the oscillator is off the resonant frequency of the circuit by approximately 3.9 per cent. This is but slightly detuned, meaning that the impedance presented to a current of oscillator frequency will be appreciable, in fact, the impedance of this circuit will offer an impedance of approximately 14,600 ohms. So the voltage developed at the oscillator frequency will be a function of current due to the space charge coupling and the impedance presented. If the I.F. were made

higher, the impedance would be considerably less. This problem will be discussed in succeeding lessons.

It is also evident that if the space charge coupling were decreased, the voltage developed will be less, diminishing with diminishing space charge coupling.

106 { The effect of this undesirable coupling between oscillator and input circuits introduces a voltage of oscillator frequency in the signal circuit. As the signal circuit is tuned through the oscillator frequency, the capacitance being increased from minimum toward maximum, the plate current first increases, passes through a maximum, decreases rapidly to a minimum and returns slowly to its initial value. (This assumes that the signal circuit is tunable independently of the oscillator circuit.) The maximum and minimum indicates maximum in-phase and out-of-phase components of oscillator frequency voltage at the control grid of the converter. This voltage may either add or subtract vectorially to the signal voltage to either overload or decrease the mixer input, thus resulting in possible distortion due to overload or to decrease in output of the mixer and for this reason is undesirable.

The receiver designer can eliminate the coupling by a common circuit element by the use of circuits which do not require this element but he must depend on the tube manufacturer for a tube in which the effect of space charge coupling is reduced. The tube designer has met the challenge by the development of better mixer tubes which alleviate the coupling due to space charge with the production of the mixer tube Types 6L7, 6K8 and 6SA7 to name a few.

It has been shown that space charge coupling occurs when the signal grid is brought under the influence of a space charge varying at oscillator frequency. It is also known that modulation of the suppressor is advantageous to diminish this coupling effect but has the serious handicap of lowering the plate impedance. The 6L7 was developed by the RCA tube engineers to take advantage of the use of an outer grid for modulation and to minimize space charge coupling.

The 6L7 has five grids and is called a pentagrid mixer tube. It is used with a separate oscillator. The grids are arranged in concentric circles about the cathode with the plate as the outermost element. No. 1 grid is the signal

grid and has a variable μ characteristic to minimize cross-modulation effects. Grids No. 2 and 4 are tied together internally to shield the No. 3 grid, also to function in the normal capacity of the accelerator grid. The No. 3 grid is the point of application of the modulating voltage from the oscillator. This grid has been designed to have a large amplification factor to reduce the need for large oscillator output, a disadvantage in ordinary suppressor grid modulation. The No. 4 grid acts with the No. 2 grid for screening and it also serves to maintain the plate resistance at a high value in contrast to the effect of plate resistance reduction in the ordinary pentode with suppressor grid modulation. The No. 5 grid is internally connected to the cathode and serves to reduce secondary emission, secure high plate resistance and permit operation at low plate voltages.

A recommended circuit for the 6L7 is shown in Figure 29.

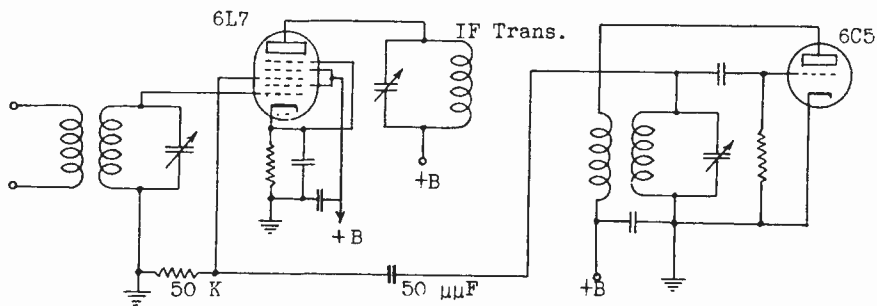

Fig. 29.

The following measured advantages over pentagrid converters of the -A7 type are reproduced from the February 1936 issue of the Proceedings of the Institute of Radio Engineers: "1. An increase in gain of between 5 and 8 to 1 at twenty megacycles. 2. Appreciably less oscillator power, resulting in improved oscillator stability. 3. Improved selectivity and increased gain in the first I.F. circuit because of the high R_p . 4. Easier alignment of tuned circuits due to less reaction between radio-frequency and oscillator circuits. 5. A greater range of operating frequencies. Good results have been obtained at 60 MC/s, whereas -A7 types will not operate well at frequencies above 40 MC/s even when a separate oscillator is used. At 40 MC/s, the improvement in sensitivity was measured as a 20 to 1 ratio over that of the

pentagrid converter circuit."

The 6L7 also functions well as an R.F. amplifier in addition to its role as an excellent pentagrid converter.

The 6L7 pentagrid mixer tube unfortunately requires a separate oscillator tube. This made its use restricted to more expensive receivers. Manufacturers desired a tube combining oscillator and mixer in the same envelope for their cheaper receivers. This led to the development of the triode-hexode converter tube Type 6K8. This tube has the oscillator section on one side of the cathode and the mixer section on the other side. A cross section of the tube is shown in Figure 30. In this tube, the oscillator grid and the No. 1 grid of the

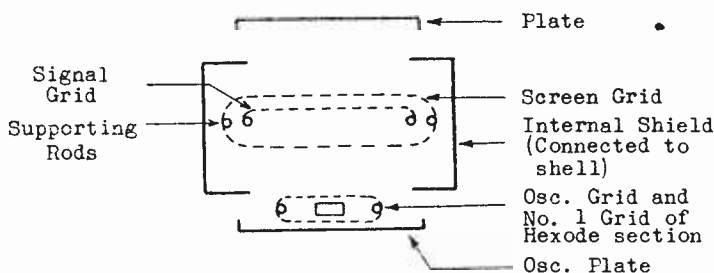

Fig. 30.

hexode unit are internally connected as shown. A rectangular cathode is employed to obtain the maximum cathode area, thus insuring high oscillator transduc-

tance without sacrificing too much conversion transconductance. The construction also enables sufficient shielding between mixer and oscillator sections. The inherent beam action of the shields aids in suppressing secondary emission and raises the plate resistance.

A circuit for such a tube as the 6K8 is shown in Figure 31.

The high oscillator transconductance enables the set designer to use a small plate coil since much less feedback is required for the 6K8 in contrast to the -A7 types. This means minimum reaction between the tuned grid circuit and the plate circuit.

A deficiency in the operation of the -A7 converter types, not previously mentioned, is the effect on oscillator frequency as the AVC bias is varied on the mixer section. Where the electron stream is affected by the AVC bias, there results a shift in oscillator tuning which may be great enough to shift the intermediate frequency by 30 or more KC/s in the higher frequency bands of the receiver. This usually results in a form of "motor-boating." The 6K8, while

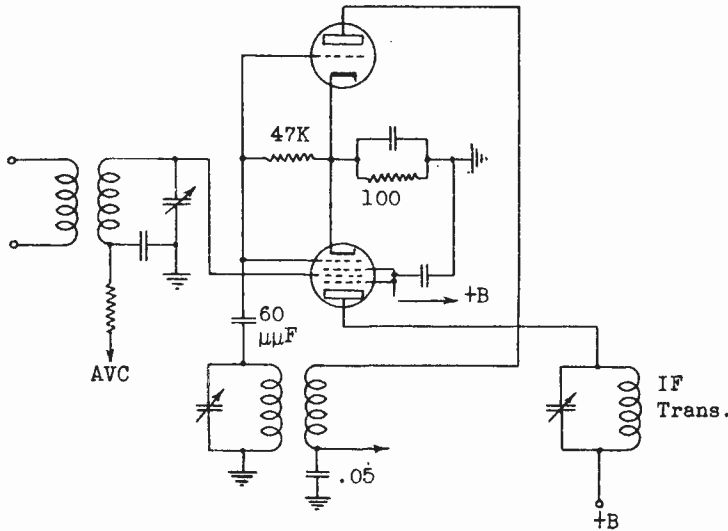

Fig. 31.

not eliminating this effect, greatly reduces it. The greatest frequency shift observable in the 6K8 circuits is 5 KC/s in sharp contrast to observed frequency shifts as high as 50 to 60 KC/s in the 6 to 18 MC/s band in receivers using the -A7 tube when a strong signal is

tuned in near the high frequency end. The effect of "motor-boating" is least in the broadcast band but is sometimes observed.

The 6SA7 is a single-ended converter tube of the pentagrid class. It differs structurally from other tube types in the following respects: (1) All electrodes terminate at the base pins (2) there is no electrode which functions solely as an oscillator anode. The structure is shown in Figure 32. The tube has a heater, cathode, a grid G_1 for the oscillator function, a screen G_2 and G_4 , a pair of collector plates mounted on the side rods of G_2 , a signal grid G_3 , a suppressor grid G_5 and a plate.

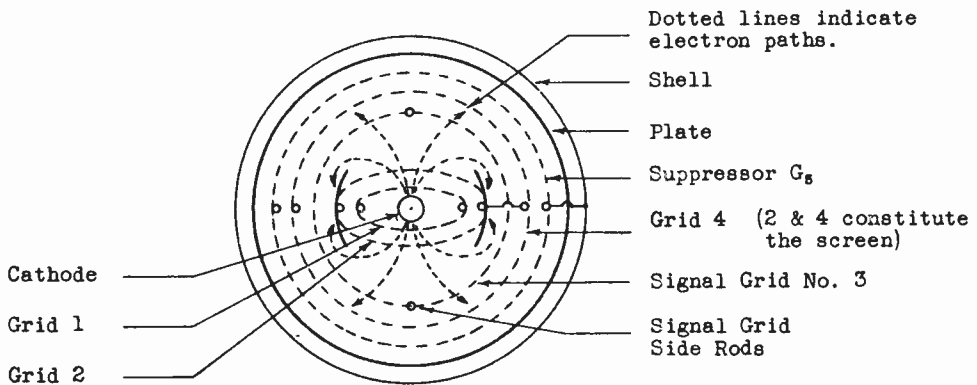

Fig. 32.

The presence of the suppressor increases the plate resistance, hence the gain. A very important function of the screen and collector plates is to minimize the effect of signal grid voltage on the space charge near the cathode. The negative voltage on the signal grid repels electrons on their way to the plate and turns some of them back toward the cathode. Their paths are shown in Figure 32. Any of these electrons which reach the region of the cathode will affect the space charge in that region. Because of the position of the collector plates, they intercept most of these returning electrons, thereby reducing the effect on the space charge near the cathode. The signal grid's electrostatic field also affects the space charge only slightly because of the shielding effect of the screen. This results in little change of the cathode current with changes of voltage on the signal grid. This is so because, while a change in plate current occurs when the voltage on the signal grid is changed, it is compensated by an almost equal and opposite change in the screen current. Also because voltage on the signal grid has little effect on the space charge near the cathode, changes in AVC bias produce little change in oscillator transconductance, hence small detuning of the oscillator.

A typical circuit employing the 6SA7 is shown in Figure 33.

It is not possible to cover all possible combinations of oscillator and mixer as employed in receivers in service but the important types have been emphasized. For further information the student is urged to study the RCA Receiving Tube Manual to supplement the information contained in this discussion.

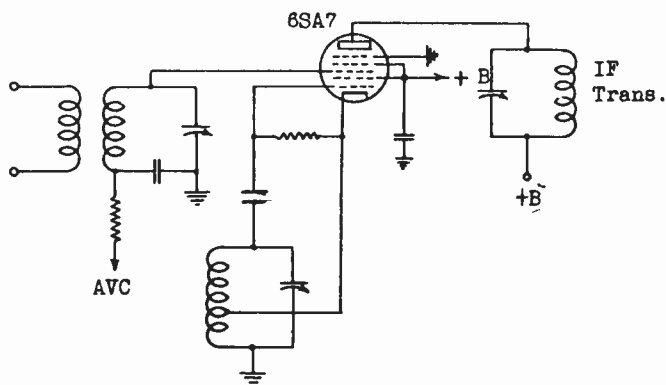

Fig. 33.

THE VACUUM TUBE AS A DETECTOR
EXAMINATION

1. (a) It is desired to operate an R.F. amplifier as a frequency doubler. Explain in detail the circuit and voltage adjustments for maximum power output.

The resonant LC plate circuit is tuned to double the frequency of the exciting voltage. Highest safe value of plate voltage is used, the bias voltage is approximately twice the value for plate current cut-off, and the exciting voltage is adjusted so that plate current flows $\frac{1}{4}$ of the time for each excitation cycle.

- (b) A transmitter is to operate on 3105; 6210; and 9315 KC/s using all stages in each case. Explain how this may be accomplished with one crystal oscillator stage, one frequency multiplier and only one crystal. List the circuit conditions and voltage adjustments for each case.

Use crystal ground to ^{oscillate} operate at 3105 kc/s.
 For 3105 kc/s operation normal plate voltage, bias voltage & excitation are employed and the plate tank is tuned to 3105 kc/s so the stage operates as a straight amplifier.
 For 6210 kc/s operation tune plate tank ^{of second stage} to 6210 kc/s, increase plate voltage to highest safe value, adjust bias to twice cut-off value and excitation so plate current flows $\frac{1}{4}$ time for each excitation cycle.
 For 9315 kc/s operation, tune plate tank of second stage to 9315 kc/s, use highest safe value plate voltage and increase bias & excitation voltages so plate current flows $\frac{1}{4}$ of time for each excitation cycle.

THE VACUUM TUBE AS A DETECTOR

EXAMINATION, Page 4.

6. You wish to use grid leak detection with quite large signal voltage. Modulation up to 60 per cent at frequencies up to 6,000 cycles must be handled with minimum distortion. You wish to use a .25 megohm grid leak. What capacity would you use? Show all your work.

$$\frac{X}{R} \approx \frac{m}{\sqrt{1-m^2}} \quad \frac{m}{\sqrt{1-m^2}} = \frac{.6}{\sqrt{1-.36}} = \frac{.6}{.8} = .75$$

$$\frac{X}{R} = .75 \quad R = 250,000 \Omega$$

$$X = .75 \times 250,000 = 187,500 \Omega$$

$$C = \frac{1}{2\pi F X} = \frac{1}{6.28 \times 6000 \times 187,500} = \underline{\underline{142 \mu F}}$$

7. With 60 microvolts rms carrier input to a receiver having a radio frequency amplification of 130,000 to the diode detector input, determine the rms value of the A.C. modulation component to the input to the detector for a 40 per cent modulated signal.

$$E_{RMS} = \text{RMS carrier volt. to detector} = .00006 \times 130,000 = 7.8 \text{ v.}$$

$$E_{AF} = E_{RMS} \times m = 7.8 \times .40 = \underline{\underline{3.12 \text{ volts}}}$$

THE VACUUM TUBE AS A DETECTOR

EXAMINATION, Page 5.

8. If the diode load resistor of the diode of problem 7 consists of a 50,000 ohm resistor (R_1 of Fig. 19) in series with a 300,000 ohm resistor (R_2 of Fig. 19), determine the A.C. modulation component (rms) available at the grid of the first audio tube. Use the input voltage of problem 7 and 90% efficiency for the detector stage. *See solution*

$$E_{\text{at first audio grid}} = 3.12 \times .90 = \underline{\underline{2.81 \text{ Volts}}}$$

The reduction in E , owing to the presence of the R-filter, must be taken into consideration. See bottom of page 30 of text.

9. (a) If the average value of the rectified current is 100 microamperes for a diode resistor of 350,000 ohms and the diode is a 6H6, what is the D.C. voltage developed across the diode load resistor for this current?

$$\begin{aligned} \text{D.C. Voltage} &= IR = .000100 \times 350,000 \\ &= \underline{\underline{35 \text{ Volts}}} \end{aligned}$$

- (b) What is the rms input voltage required for this current? Use the tube curves.

$$\text{Approx. } \underline{\underline{27.5 \text{ Volts}}}$$

THE VACUUM TUBE AS A DETECTOR

EXAMINATION, Page 6.

9.

10. (a) What are the requirements of a good mixer tube?

1. High trans conductance in both mixer and oscillator sections.
2. Minimum reaction between oscillator & mixer sections.
3. Low tube noise
4. Usable with simple circuits for ease of switching problems.
5. High oscillator stability

(b) What is space charge coupling? Explain how space charge coupling may cause overload and distortion in a receiver.

Space charge coupling is caused by the space charge varying at oscillator frequency adjacent to the signal grid. This causes a voltage at oscillator frequency to be induced in the grid. Periodically the plate current will increase due to in-phase components of the oscillator frequency voltage at the grid and periodically it will decrease due to out of phase components. Therefore the plate current variations will not be linear with the signal voltage variations.

EXAMINATION SOLUTIONS
 FREQUENCY MULTIPLYING, THE VACUUM TUBE AS A DETECTOR

2. It is desired to check a frequency of 2605 KC/S by means of a heterodyne frequency meter and a 150 KC/S crystal calibrator. The nearest harmonic frequencies of the crystal calibrator zero beat with the H.F.M. at 475 and 595 divisions on the tuning dial. What is the correct setting for 2605 KC/S?

ANSWER: It is assumed that the tuning dial divisions on the H.F.M. are directly proportional to the frequency.

$\frac{2606 \text{ KC/S}}{150 \text{ KC/S}} = 17.36$ This shows that the desired dial setting lies between the dial settings for the seventeenth and eighteenth harmonics of the 150 KC crystal.

475 dial divisions = 17th harmonic = $17 \times 150 = 2550 \text{ KC/S}$.
 595 dial divisions = 18th harmonic = $18 \times 150 = 2700 \text{ KC/S}$.
 2605 - 2550 = 55 KC/S difference

Proportional increase over 475 setting = $\frac{55}{150} \times 120 = 44$ divisions

Correct setting for 2605 KC/S = $475 + 44 = 519$ divisions Ans.

6. You wish to use grid leak detection with quite large signal voltage. Modulation up to 60 per cent at frequencies up to 6000 cycles must be handled with minimum distortion. You wish to use a .25 megohm grid leak. What capacity would you use? Show all your figures.

Answer:
$$\frac{X}{R} = \frac{M}{\sqrt{1 - M^2}} = \frac{.6}{\sqrt{1 - .6^2}} = \frac{.6}{\sqrt{1 - .36}} = \frac{.6}{\sqrt{.64}} = .75$$

$$X = .75R = .75 \times .25 \times 10^6 = 187,600 \text{ ohms}$$

$$X_c = \frac{1}{2\pi FC} = \frac{1}{6.28 \times 6000 \times 187,600} \text{ farads}$$

$$C = \frac{10^{12}}{6.28 \times 6 \times 1.876 \times 10^8} = 141 \mu\mu\text{F} \quad \text{Ans.}$$

7. With 60 microvolts rms carrier input to the receiver having a radio frequency amplification of 130,000 to the diode detector input, determine the rms value of the A.C. modulation component for a 40 percent modulated signal.

Answer: Diode detector input = $60 \times 10^{-6} \times .13 \times 10^6$
 $= 60 \times .13 = 7.8 \text{ volts RMS}$

$$E_{af} = E_{rms} \times m = 7.8 \times .4 = \underline{3.12 \text{ volts RMS}} \quad \text{Ans.}$$

8. If the diode load resistor of the diode of Problem 7 consists of a 50,000 ohm resistor (R_1 of Figure 19) in series with a 300,000 ohm resistor (R_2 of Figure 19), determine the A.C. modulation component (rms) available at the grid of the first audio tube. Use the input voltage of Problem 7.

Answer:

The diode efficiency is assumed to be 90 per cent.

$$\begin{aligned}
 \text{A.C. modulation component} &= \frac{R_2}{R_1 + R_2} \times E_{a,r} \\
 &= \frac{300,000}{50,000 + 300,000} \times .9 \times 3.12 \\
 &= \frac{9.36 \times .9}{3.5} \\
 &= 2.4 \text{ volts RMS} \qquad \text{Ans.}
 \end{aligned}$$

9. (A) If the average value of the rectified current is 100 microamperes for the diode resistor of Problem 8 and the diode is a 6H6, what is the DC voltage developed across the diode load resistor for this current?

Answer: Note that the diode load circuit consists of *both* R_1 and R_2 in series.

$$\begin{aligned}
 R_1 + R_2 &= 50,000 + 300,000 = 350,000 \text{ ohms} \\
 &= .35 \times 10^6 \text{ ohms} \\
 E = IR &= 100 \times 10^{-6} \times .35 \times 10^6 = 35 \text{ volts} \qquad \text{Ans.}
 \end{aligned}$$

(B) What is the rms input voltage required for this current?

Answer: Draw the load line through the point (-35 volts, 100 μ -amperes) and point (0 volts, 0 μ -amperes) on Figure 15, page 29 of the assignment text. Sketch in a curve through the point (-35 volts, 100 μ -amperes) parallel or similar to the curves for RMS signal input voltages of 20 and 30 volts. By interpolation or the use of proportion, the RMS signal input equals 27 volts. Ans.

THERMIONIC EMISSION

EXAMINATION

1. (A) On what basic fact is thermionic emission dependent?

Thermionic emission is dependent on heating a metal to a sufficient temperature to cause free electrons to be evaporated from it.

- (B) What is meant by work function?

Work function is the amount of energy an electron requires to overcome the attractive forces holding it to the metal, thus allowing it to escape from the surface beyond the field of attraction of the surface of the metal.

THEMIONIC EMISSION

EXAMINATION, Page 2.

2. Why are work function and melting point important factors when selecting a filament material?

With a low work function less energy is required for the electron to be expelled. The higher the melting point the less danger of evaporation of atoms from the filament at the temperature required for thermionic emission

3. List the advantages and disadvantages of tungsten, thoriated, and oxide-coated filaments.

Tungsten, ^{has strong affinity for residual gas, is not sensitive to ionic bombardment.} due to its melting point is the only one of three used in high power transmitters because it is the only one that can stand the high evacuating temperature.

Disadvantages - short life & high power consumption, ^{tends to become brittle with age}

Thoriated filament has much greater emission efficiency, ^{if operated at high temp.} than tungsten, and longer life than tungsten, but it

has a low melting point and is sensitive to ionic bombardment.

Oxide coated filaments have long life and high emission efficiency but due to low melting point can be used only with low plate voltages so is limited to use in receivers, etc.

Difficult to evacuate

THERMIONIC EMISSION

EXAMINATION, Page 3.

4. What is the primary advantage of indirectly heated cathodes and what are the problems encountered in the design of such emitters?

A.C. can be used for heater supply without introducing hum into the signal. Some problems are: short circuit between heater & cathode, vibration of heater wires, sag in heater wires at high temperatures, induced currents in cathode & grid, delay in heating

5. (A) What limits the operating temperature of the anode in a radiation cooled vacuum tube?

The walls of the tube have to dissipate the heat radiated by the platf. As the plate dissipation is increased the glass tube or envelope has to be enlarged.

THERMIONIC EMISSION

EXAMINATION, Page 4.

- 5. (B) Why is it an advantage to operate the anode of a radiation cooled tube at a fairly high temperature?

Because the amount of energy that can be radiated varies proportionately to the fourth power of the absolute temperature.

Thus, for some P (as at a lower temperature), if the temperature of the anode can be increased, the size of the anode can be reduced, thereby

- 6. What are the advantages and disadvantages of tungsten, molybdenum, and graphite as anode materials? ^{reducing interelectrode capacitance}

Tungsten has { high melting point, high gas adsorption and is therefore good for high power radiation cooled tubes. Because it has to be worked hot its use is restricted to high power tubes.

Molybdenum can be worked cold but it is so tough as to wear out tools used to work it.

Graphite is the nearest to the ideal heat radiator - a black body. Graphite plates are thicker so the heat distribution is more uniform. Gas adsorption is higher so special treatment is required to reduce evacuation time. Has low tensile strength.

see 8 & 9 lines from letter by page 22 column 2

THERMIONIC EMISSION

EXAMINATION, Page 5.

7. A thoriated filament tube rated at 50-watts plate dissipation shows a plate current somewhat below normal when all other tube voltages are correct. What steps would you take to remedy the condition? If the tube does respond to treatment what is the most probable reason?

Remove plate voltage at operate filament at twice normal voltage for about 20 seconds, and then for 1 to 2 hours at 1.2 normal filament voltage. Tube had probably been operated at too low temperatures so surface thorium had evaporated too fast to be replenished by thorium from inside. The above process drives inside thorium to the surface of the filament

8. (A) In a two-element vacuum tube what forces are acting on the emitted electron?

If the electron is near the cathode the electrons in the space charge tend to repel it back to the cathode, while the plate tends to attract it. If it is farther out, the electrons between it and the cathode repel it towards the plate. All emitted electrons are acted on by forces of the plate and of the space charge.

Thermionic Emission

EXAMINATION, Page 6.

- 8. (B) How does the filament temperature affect the size of the electron cloud? Does the general distribution of electrons in the space charge change with filament temperature?

With no change in plate voltage, increasing the filament temperature increases the size of the electron cloud until space charge is maximum! With increased filament temperature the electron cloud will be denser near the cathode, as the plate won't draw off all that are emitted by the cathode. With temperature limitation the distribution in the interelectrode space would be more even.

(A) Tube potentials are measured with respect to what point in a vacuum tube circuit? Why?

Reference point is the cathode. The cathode is the point of origin of the emitted electrons and the electron stream is controlled by means of the other elements being either negative or positive with respect to the cathode. The cathode is therefore the logical reference point.

The general distribution of electrons in the space charge is not uniform as varying potentials will fill the space charge. Since the space charge is always more positive in the vicinity of the cathode than in the vicinity of the plate.

THERMIONIC EMISSION

EXAMINATION, Page 7.

9. (B) What is space-charge limitation of current? Temperature limitation of current?

Space charge limitation is when the repelling force of the electrons between the elements balances the attracting force of the plate, so no electrons leave the filament till some from the interelectrode space arrive at the plate. Increasing plate voltage increases current flow. Temperature limitation is in effect when all the electrons emitted by the filament at a certain temperature are drawn over to the plate. Increasing plate voltage does not further increase the current.

10. (A) Why it is preferable to employ a.c. rather than d.c. for the filaments of vacuum tubes?

Because with DC one end of the filament will be more negative than the other with respect to the plate. Emission therefore will be greater from this end, increasing the temperature which will cause faster volatilization of the filament so it will disintegrate sooner.

Also, a.c. is more economical & convenient.

THERMIONIC EMISSION

EXAMINATION, Page 8.

10. (B) If d.c. must be used, what precautions should be exercised to prolong the life of the filament.

The polarity of the DC supply to the filament should be reversed periodically by a reversing switch.

POWER SUPPLIES

EXAMINATION

NOTE: In the following problems m.v. refers to the hot-cathode mercury vapor rectifier tube. Underline the correct answer. One answer per problem.

1. (A) The m.v. tube operates with a (low, average, high) gas pressure.

The tungar rectifier tube operates with a (low, average, high) gas pressure.

(B) In normal operation, the gas pressure in a m.v. tube depends on the (degree of ionization, voltage drop across the tube, coldest part of tube).

(C) In normal operation, the current through a m.v. tube is (essentially equal to, less than, greater than) the amount of electrons emitted by the filament.

(D) In normal operation, the voltage drop across the m.v. tube (varies with the load, is essentially constant, increases with an increase in ionization).

(E) In normal operation, the degree of ionization in a m.v. tube is only sufficient to (produce rated tube drop, cancel space charge, prevent flash-back).

2. (A) In normal operation, the current through a tungar rectifier is (equal to peak filament emission, essentially equal to the amount of electrons removed from the gas, composed of equal amounts of gas and emitted electrons).

(B) If the internal resistance of a m.v. tube exceeds the critical value (the gas pressure falls, the gas pressure rises, ionic bombardment of the filament occurs, regulation is poor).

(C) If the temperature of a m.v. is too high, the distance between the gas atoms (is reduced, is increased, remains the same, is quadrupled).

(D) If the temperature of a m.v. tube is too low (the voltage drop across the tube increases, the voltage drop across the tube decreases, negative ions bombard the filament).

(E) The above (2-d), is true because (the space charge is not completely cancelled, ionization increases, the negative plate repels the negative ions).

POWER SUPPLIES

EXAMINATION, Page 2.

3. (A) Too high a gas pressure in a m.v. tube increases the danger of (excessive plate current flow, flash-back, the tube exploding).
- (B) Too low a gas pressure in a m.v. tube increases the danger of (flash-back, the filament being destroyed by positive ion bombardment, excessive current flow due to decrease in internal resistance).
- (C) Mercury vapor rectifier tubes should never be operated (with condenser-input filters, without grid bias, without temperature controlled chambers) otherwise excessive plate current will flow and damage the tube.
- (D) A filter system for a half-wave high-vacuum tube rectifier power supply uses a (condenser-input, choke-input, either a condenser-input or choke-input) design.
- (E) Before drawing load current from a rectifier equipped with mercury vapor tubes, the m.v. tubes should be (tested for peak filament emission, warmed up, checked for maximum inverse flash-back voltage).

4. A receiver requires 90 ma at 250 volts. The two chokes to be used are rated as follows: 12 henries at 125 ma with a resistance of 200 ohms; 6 henries at 125 ma with a resistance of 100 ohms. Bleeder current (not included in the 90 ma) is 10 ma. A choke input filter is to be used. The rectifier is a type 80 tube for which the voltage drop at each value of current must be found from the curves in the tube manual.

(A) What r.m.s. voltage per plate must be used on the rectifier tube?

$$\text{Total } I = 90 + 10 = 100 \text{ MA.}$$

$$\text{Total } R = 200 + 100 = 300 \Omega.$$

$$\text{IR drop in chokes} = 300 \times .1 = 30 \text{ V.}$$

$$\text{Volts in to filter} = 250 + 30 = 280 \text{ V.}$$

At 280 V. DC out of rectifier with
100 MA — from curves ERMV per
plate = approx 380 Vots

POWER SUPPLIES

EXAMINATION, Page 3.

4. (B) Assuming the transformer voltage output to the rectifier tube to be constant, what is the approximate voltage regulation in per cent? Keep in mind the IR drops in the choke. The regulation is the relation of no load voltage minus full load voltage divided by the full load voltage. This refers to the change in voltage at the filter output, not the voltage change at the rectifier output. The receiving tube manual curves can be used to good advantage to determine the voltage drop in any high-vacuum rectifier tube, since the drop varies with the load current and other factors. The bleeder resistance draws current regardless of load.

With 10 MA -
from curve - with $E_{RMS} = 380V$ output of rectifier = 325V

IR drop in chokes = $300 \times .01 = 3V$.

Filter output = 322 V.

$$\text{Regulation} = \frac{322 - 250}{250} \times 100 = \frac{72}{250} \times 100 = \underline{\underline{28.8\%}}$$

5. Reference problem 4.

(A) Calculate the required filter capacity to the nearest microfarad for each filter condenser. Use $f_c = 90$ c.p.s. Line frequency is 60 c.p.s.

$$LC = \frac{1}{(\pi f_c)^2} = \frac{1}{(3.14 \times 90)^2} = \frac{1}{283^2} = \frac{1}{8 \times 10^4} = 12.5 \times 10^{-6}$$

First condenser $C = \frac{LC}{L} = \frac{12.5 \times 10^{-6}}{12} = \underline{\underline{1 \mu f}}$

Second $C = \frac{LC}{L} = \frac{12.5 \times 10^{-6}}{6} = \underline{\underline{2 \mu f}}$

POWER SUPPLIES

EXAMINATION, Page 4.

5. (B) Sketch the power supply circuit showing the value of each part including the resistance of the bleeder.

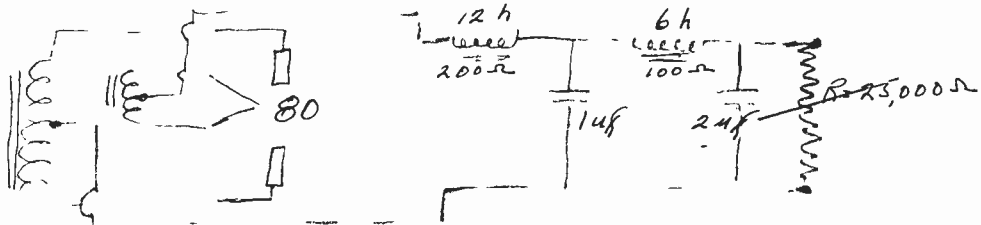

6. (A) You wish to use a four tube single-phase full-wave mercury vapor rectifier to deliver 3700 volts d.c. to the filter input. Neglecting tube drop what should a voltmeter across the transformer indicate?

$$E_{rms} = \frac{E_{av}}{.9} = \frac{3700}{.9} = \underline{\underline{4150 \text{ Volts}}}$$

- (B) How much should you increase this to make up for the tube drop?

Increase by 30 v to 4180 Volts

- (C) A power supply for a class B amplifier should have a high calculated percentage of regulation. (True or False).

- (D) A d.c. ammeter inserted in one plate lead of a full-wave rectifier will read (200 mils, 141.4 mils, 127.2 mils, 63.6 mils, 57.4 mils) if the peak plate current pulses are 200 mils.

$$\frac{200 \times 0.636}{2} = 63.6 \text{ mA.}$$

POWER SUPPLIES

EXAMINATION, Page 5.

6. (E) Sketch (1) a simple high-pass filter, and (2) a simple low-pass filter.

(1).

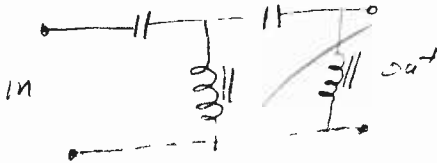

(2).

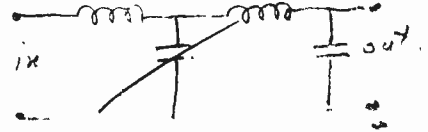

7. You wish to design a full-wave three-phase mercury vapor rectifier to deliver 5 amperes at 10,000 volts d.c. to a load. The filter reactors have a total resistance of 40 ohms. The primary supply is 220 volts at 60 cycles. The transformer is connected delta Y.

(A) What is the d.c. voltage that must be delivered to the input of the filter?

$$IR \text{ drop} = 5 \times 40 = 200 \text{ Volts.}$$

$$\text{Input voltage} = 10,000 + 200 = \underline{\underline{10,200 \text{ Volts}}}$$

(B) Neglecting the tube drop, what will be the r.m.s. voltage per leg of the secondary?

$$E_{RMS} \text{ per leg} = \frac{10,200}{2.34} = 4,360$$

POWER SUPPLIES

EXAMINATION, Page 6.

7. (C) What will be the inverse peak voltage?

$$E_{inv} = \frac{E_{average}}{.956} = \frac{10,200}{.956} = 10,680 \text{ Volts.}$$

- (D) What is the transformer turns ratio?

$$\text{Turns ratio} = \frac{4,360}{220 \times \cancel{4.77}} = \frac{4,360}{380} = 11.5 \text{ or } 12 \cancel{X}$$

$$19.8 : 1$$

- (E) What power will be furnished by the secondary?

$$P_{sec} = 10,200 \times 5 = \frac{51,000 \text{ W. or } 51 \text{ KW}}{0.955 \text{ (Sec. Util. Factor)}} = 53.4 \text{ KW}$$

8. Reference problem 7. The power must be delivered to the load with a ripple component not to exceed .2 per cent. You have two high voltage filter condensers, $1\mu\text{F}$ and $1.5\mu\text{F}$. Design a two section filter using these condensers that will provide the proper attenuation of the ripple voltage. It must be remembered that the ripple at the input to the filter is not equal to 100 per cent of the d.c. voltage at that point, and the final per cent of ripple will therefore not be equal to the attenuation ratio. Each section should have the same cut-off frequency. What is it?

POWER SUPPLIES

EXAMINATION, Page 7.

8. Ripple component in filter out = $10,200 \times 0.002 = 20$ Volts.
 From Table 1: ripple to filter in = $.057 E_{av}$
 $= 10,200 \times 0.057 = 582$ volts

$$\text{Filter Attenuation factor} = \frac{20}{582} = .0344$$

$$.034 = \frac{1}{(2\pi f)^4 L_1 L_2 C_2 C_1} \quad L_1 L_2 = \frac{1}{.034 (2\pi f)^4 C_1 C_2}$$

$$L_1 L_2 = \frac{1}{.034 (6.28 \times 360)^4 \times 1.5 \times 10^{-12}} = \frac{.751}{.745}$$

$$L_1 = 1.5 L_2$$

$$1.5 L_2^2 = .751$$

$$L_2 = \sqrt{\frac{.751}{1.5}} = \frac{.71}{1.06} \text{ h}$$

$$L_1 = .595 \times 1.5 = \frac{.865}{1.06} \text{ h}$$

$$\text{Use } L_1 = .9 \text{ h.} \quad L_2 = .6 \text{ h.}$$

$$L_1 C_1 = 1 \times 10^{-6} \times .9 = .9 \times 10^{-6}$$

$$L_2 C_2 = 1.5 \times 10^{-6} \times .6 = .9 \times 10^{-6}$$

$$F_c = \frac{1}{\pi \sqrt{LC}} = \frac{1}{3.14 \sqrt{.9 \times 10^{-6}}} = \frac{336}{1.06} \text{ c.p.s.}$$

$$F_c = \frac{1}{3.14 \sqrt{1 \times 1006 \times 10^{-6}}} = \frac{309}{1.06} \text{ c.p.s.}$$

POWER SUPPLIES

EXAMINATION, Page 8.

9. Two tubes are used in a Class B amplifier with a plate voltage of 400 volts. The total plate current for the two tubes varies from 12 ma at no signal to 100 ma for full signal. Bear in mind that the bleeder current is flowing through the filter at all times, regardless of load.

(A) Determine the bleeder resistance that must be placed across the filter output if the range of variation for the total current supplied by the rectifier is 4 to 1. Assume zero voltage regulation for the rectifier and filter. Values must be calculated, not assumed; i.e. the current variation of 4 to 1 fixes the bleeder current value.

$$(I_b + 100) : (I_b + 12) = 4 : 1$$

$$4I_b + 48 = I_b + 100$$

$$3I_b = 52 \quad I_b = 17.3 \text{ MA.}$$

$$R_b = \frac{400}{.0173} = 23,100 \Omega$$

(B) If a swinging choke is used as the first element in the filter what should be its specifications?

at full signal $I = 117.3 \text{ MA}$

$$R_L = \frac{400}{.1173} = 3373410 \Omega$$

$$L_c = \frac{3410}{1000} = 3.4 \text{ h.} \quad L_0 = 6.8 \text{ h.}$$

at no signal $I = 29.3 \text{ MA}$

$$R_L = \frac{400}{.0293} = 13,700 \Omega$$

$$L_c = \frac{R}{1000} = \frac{13,700}{1000} = 13.7 \text{ h.}$$

$$L_0 = 27.4 \text{ h.}$$

Spec. for choke: 7.5 henries at 120 MA load
30 henries at 30 MA load

POWER SUPPLIES

EXAMINATION, Page 9.

10. Find resistance of each numbered resistor. Bleeder I = 10 ma. Show all work.

$$R_1 = \frac{E}{I} = \frac{8}{.0005} = 16,000 \Omega$$

$$R_2 = \frac{E}{I} = \frac{3}{.0045} = 667 \Omega$$

$$R_3 = \frac{E}{I} = \frac{7}{.0005} = 14,000 \Omega$$

$$R_4 = \frac{E}{I} = \frac{9}{.0045} = 2,000 \Omega$$

$$R_5 = \frac{E}{I} = \frac{50}{.65} = 770 \Omega$$

$$R_8 = \frac{E}{I} = \frac{135}{.01} = 13,500 \Omega$$

$$R_7 = \frac{E}{I} = \frac{30}{.0125} = 2,400 \Omega$$

$$R_6 = \frac{E}{I} = \frac{15}{.015} = 1,150 \Omega$$

$$R_9 = \frac{E}{I} = \frac{120}{.0225} = 5,330 \Omega$$

EXAMINATION

POWER SUPPLIES

PROBLEM 10. Find resistance of each numbered resistor. Bleeder I = 10 MA.
Show all work.

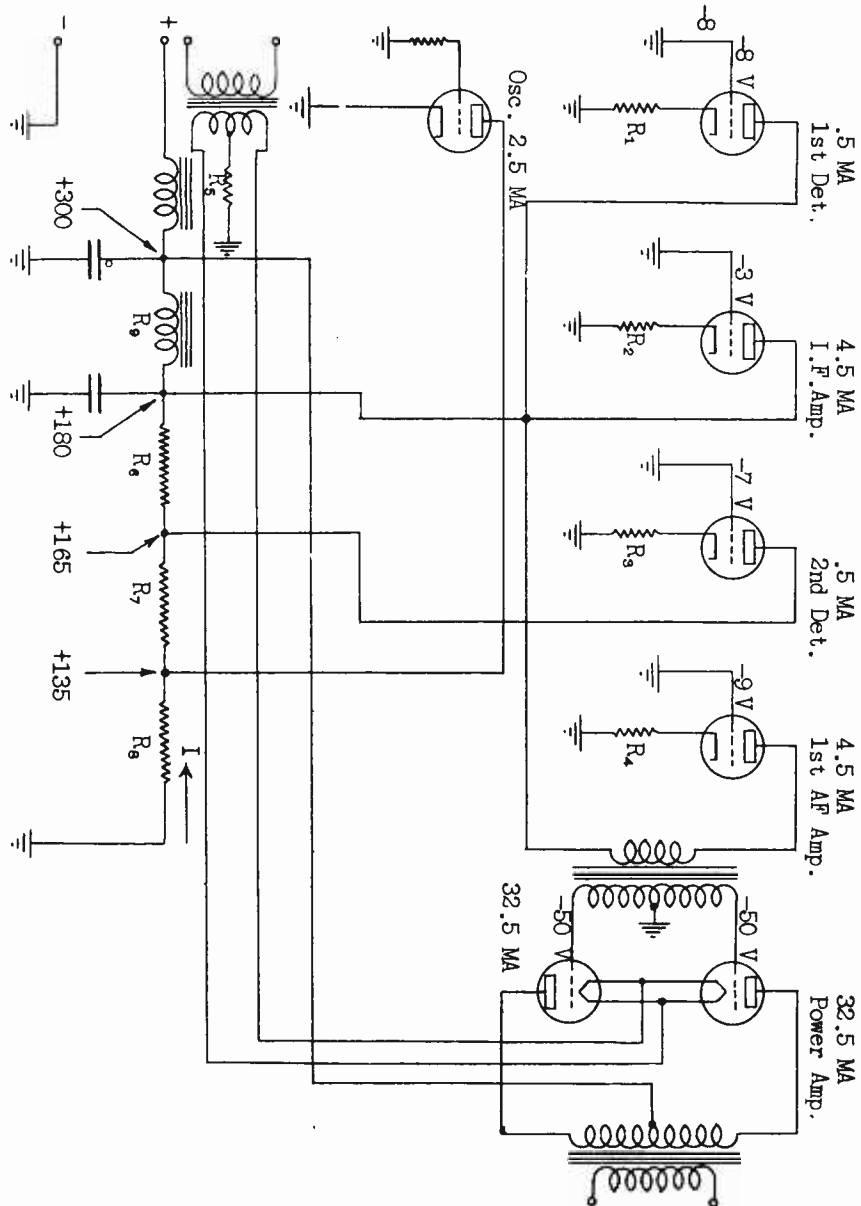

SOLUTION OF PROBLEM 4 POWER SUPPLIES

A receiver requires 90 MA at 250 volts. Two chokes are available rated as follows: 12 henries at 125 MA with a resistance of 200 ohms; 6 henries at 125 MA with a resistance of 100 ohms. Bleeder current is 10 MA. A choke filter input is to be used. The rectifier is a type 80 tube.

- (a) What RMS voltage per plate must be used on the rectifier tube?
- (b) What is the approximate voltage regulation in per cent,

Reference to the receiving tube manual indicates that the type 80 rectifier tube is a full-wave rectifier of the high vacuum type. As the internal drop of the high vacuum rectifier varies under varying load currents the simple relationship between the RMS plate voltage and E_{ave} found with the mercury vapor rectifier does not apply. To allow prediction of vacuum type rectifier performance using different plate voltages and changing load currents sets of operational characteristic curves must be provided. For the 80, as with all high vacuum rectifier tubes, curves showing performance using both condenser and inductance input to the filter are given in the tube manual.

It will be observed that the 80 must be operated under conditions which are the same as for the type 5Y3-G and therefore the characteristic curves of the 5Y3-G should be studied. The "choke input to filter" curves are of special interest in this problem and it will be observed that from these curves, by knowing any two of the three factors involved, the other factor can be obtained.

(a). With the receiver drawing 90 MA and with a 10 MA bleeder current the full load drain on the rectifier must be $90 + 10$ or 100 MA. This current flows through both chokes, whose total resistance comes to $200 + 100$ or 300 ohms.

$$\text{Choke Drop} = IR = .1 \times 300 = 30 \text{ volts.}$$

This additional voltage must be supplied by the rectifier and as the choke drop is in series with the rectifier load the voltage at the filter input must be $250 + 30 = 280$ volts.

The D.C. output voltage of the rectifier must equal the required D.C. input voltage to the filter input so the RMS voltage per plate of the rectifier tube must be such that the D.C. output voltage equals 280 volts with a load current of .1 ampere.

Careful interpolation on the choke input to filter curves (see next page) show that the type 80 tube operating under the above conditions requires an RMS voltage per plate of approximately 375 volts.

The curves reproduced at the right indicate how this interpolation should be made. Even though the curves are small, care in proportioning the divisions of the graph will permit sufficient accuracy for all practical purposes.

The 375 V RMS per plate curve has been drawn in midway between the given 350 and 400 volt curves for the sake of clarity.

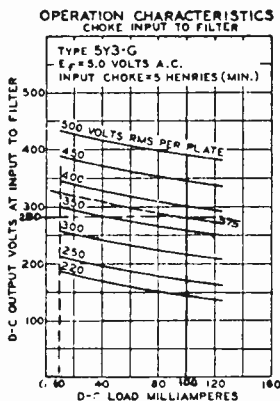

(b). The voltage regulation of any device is given by the expression:

$$\text{Percent Regulation} = \frac{E_{\text{no load}} - E_{\text{full load}}}{E_{\text{full load}}} \times 100$$

and to determine the voltage regulation of this power supply the value of $E_{\text{no load}}$ must be found.

Under no load conditions only the 10 MA bleeder current flows while the RMS voltage per plate remains essentially constant. As the internal drop of the vacuum type rectifier decreases when the load is removed, the D.C. output voltage of the rectifier is found to be approximately 320 volts.

The no load choke drop becomes $300 \times .01$ or 3 volts so the value of $E_{\text{no load}}$ at the filter output becomes $320 - 3$ or 317 volts. Knowing all factors in the above expression for percent of voltage regulation, we have:

$$\text{REGULATION} = \frac{317 - 250}{250} \times 100 = \frac{67}{250} \times 100 = 27 \text{ PER CENT}$$

POWER SUPPLIES
SOLUTIONS OF PROBLEMS 5,6,7,10

5. REFERENCE PROBLEM 4.

(A) CALCULATE THE REQUIRED FILTER CAPACITY TO THE NEAREST MICROFARAD FOR EACH FILTER CONDENSER.

THE LOWEST RIPPLE FREQUENCY IN THE OUTPUT IS 120 CYCLES/SECOND.
ASSUMING A CUT-OFF FREQUENCY OF 90 CYCLES/SECOND

$$LC = \frac{1}{(\pi F_c)^2} = \frac{1}{(3.14 \times 90)^2} = \frac{1}{283^2} = \frac{1}{8 \times 10^4} = 125 \times 10^{-7}$$

$$C = \frac{LC}{L} = \frac{125 \times 10^{-7}}{12} = 10.4 \times 10^{-7} = 1.04 \times 10^{-6} \text{ FARAD} = 1\mu \text{ FANS}$$

$$C = \frac{LC}{L} = \frac{125 \times 10^{-7}}{6} = 20.8 \times 10^{-7} = 2.08 \times 10^{-6} \text{ FARAD} = 2\mu \text{ FANS}$$

(B) SKETCH THE POWER SUPPLY CIRCUIT SHOWING THE VALUE OF EACH PART INCLUDING THE TOTAL RESISTANCE OF THE VOLTAGE DIVIDER.

$$\text{VOLTAGE DIVIDER} = \frac{E}{I} = \frac{250}{.01} = 25,000 \text{ OHMS}$$

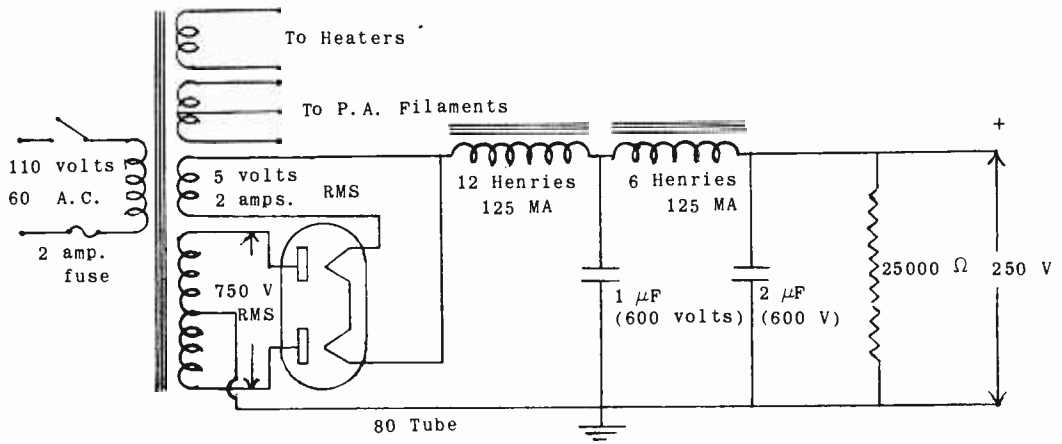

6. YOU WISH TO USE A FOUR TUBE SINGLE PHASE FULL WAVE MERCURY VAPOR RECTIFIER TO DELIVER 3700 VOLTS D.C. TO THE FILTER ACROSS THE TRANSFORMER INDICATED. HOW MUCH SHOULD YOU INCREASE THIS TO MAKE UP FOR THE TUBE DROP?

$$E_{AVE} = .9 E_{RMS}$$

$$E_{RMS} = \frac{E_{AVE}}{.9} = \frac{3700}{.9} = 4110 \text{ VOLTS RMS VOLTMETER READING.}$$

THIS SHOULD BE INCREASED BY 30 VOLTS TO MAKE UP FOR THE TUBE DROP IN THE TWO TUBES.

7. YOU WISH TO DESIGN A FULL WAVE THREE PHASE MERCURY VAPOR RECTIFIER TO DELIVER 5 AMPERES AT 10,000 VOLTS D.C. TO A LOAD. THE FILTER REACTORS HAVE A TOTAL RESISTANCE OF 40 OHMS. THE PRIMARY SUPPLY IS 220 VOLTS AT 60 CYCLES. THE TRANSFORMER IS CONNECTED DELTA Y.

(A) WHAT IS THE D.C. VOLTAGE THAT MUST BE DELIVERED TO THE INPUT TO THE FILTER?

$$\text{INPUT VOLTAGE} = 10,000 + 5 \times 40 = 10,000 + 200 = 10,200 \text{ VOLTS}$$

(B) WHAT WILL BE THE RMS VOLTAGE PER LEG OF THE SECONDARY?

$$E_{\text{AVE}} = 2.34 E_{\text{RMS}}$$

$$E_{\text{RMS}} = \frac{E_{\text{AVE}}}{2.34} = \frac{10,200}{2.34} = 4,360 \text{ VOLTS RMS}$$

(C) WHAT WILL BE THE INVERSE PEAK VOLTAGE?

$$\begin{aligned} E_{\text{INVERSE}} &= 1.045 E_{\text{AVE}} \\ &= 1.045 \times 10,200 = 10,660 \text{ VOLTS} \end{aligned}$$

(D) WHAT IS THE TRANSFORMER TURNS RATIO?

E_{RMS} OF PART (B) IS THE VOLTAGE OF ONE LEG OF THE SECONDARY, SEE FIG. 10 OF TEXT, PAGE 16.

$$\frac{\text{LEG OF SECONDARY}}{\text{LEG OF PRIMARY}} = \frac{4360}{220} = 19.8$$

(E) WHAT POWER WILL BE FURNISHED BY THE SECONDARY?

$$\begin{aligned} \text{TOTAL POWER} &= \frac{EI(\text{D.C.})}{\text{SECONDARY UTILIZATION FACTOR}} \\ &= \frac{10,200 \times 5}{.955} = \frac{51,000}{.955} = 53,400 \text{ WATTS} = 53.4 \text{ KW} \end{aligned}$$

$$\text{POWER PER LEG} = \frac{53.4}{3} = 17.8 \text{ KW}$$

10. REFER TO DIAGRAM ON EXAMINATION SHEET.

$$R_1 = \frac{E}{I} = \frac{8}{.0005} = 16,000 \text{ OHMS}$$

$$R_2 = \frac{E}{I} = \frac{3}{.0045} = 667 \text{ OHMS}$$

$$R_3 = \frac{E}{I} = \frac{7}{.0005} = 14,000 \text{ OHMS}$$

$$R_4 = \frac{E}{I} = \frac{9}{.0045} = 2,000 \text{ OHMS}$$

$$R_5 = \frac{E}{I} = \frac{50}{2 \times .0325} = \frac{50}{.065} = 770 \Omega$$

$$R_6 = \frac{E}{I} = \frac{180 - 165}{.013} = \frac{15}{.013} = 1154 \Omega$$

$$R_7 = \frac{E}{I} = \frac{165 - 135}{.0125} = \frac{30}{.0125} = 2400 \Omega$$

$$R_8 = \frac{E}{I} = \frac{135}{.010} = 13,500 \text{ OHMS}$$

$$R_9 = \frac{E}{I} = \frac{300 - 180}{.0225} = \frac{120}{.0225} = 5,330 \Omega$$

SOLUTION OF PROBLEM 8 POWER SUPPLIES

THE POWER (REFERENCE QUESTION 7) MUST BE DELIVERED TO THE LOAD WITH A RIPPLE COMPONENT NOT TO EXCEED .2 PERCENT. YOU HAVE 2 HIGH VOLTAGE FILTER CONDENSERS, $1 \mu\text{F}$ AND $1.5 \mu\text{F}$. DESIGN A TWO SECTION FILTER USING THESE CONDENSERS THAT WILL PROVIDE THE PROPER ATTENUATION OF THE RIPPLE COMPONENT. THE TWO FILTER SECTIONS SHOULD HAVE THE SAME CUT-OFF FREQUENCY. WHAT IS IT? DRAW CIRCUIT DIAGRAM OF THE FILTER SHOWING VALUE OF EACH PART.

THIS IS A 50 KW FILTER AND ECONOMY IN DESIGN IS ESSENTIAL. CHOKES TO HANDLE THIS AMOUNT OF POWER ARE EXPENSIVE SO WE MUST DESIGN FOR THE MINIMUM L THAT WILL SATISFY THE CONDITIONS STATED. THE OUTPUT VOLTAGE IS 10000 VOLTS AND THE PERMISSIBLE AC RIPPLE COMPONENT AT THE OUTPUT IS: $.002 \times 10000$ OR 20 VOLTS.

THIS IS A 3 PHASE FULL WAVE FILTER SO FOR ONE CYCLE INPUT TO ALL 3 PHASES 6 PULSATING DC PULSES WILL BE DELIVERED TO THE LOAD SEPARATED BY $360/6 = 60^\circ$. IT IS EVIDENT THE PULSES OVERLAP. IN SINGLE PHASE AC OF SINE WAVE FORM $E_{\text{RMS}} = .707 E_{\text{MAX}}$.

IT IS EVIDENT THE FACTOR .707 COULD NOT APPLY HERE SINCE E NEVER FALLS TO ZERO. THE ROOT MEAN SQUARE VOLTAGE IS THE SQUARE ROOT OF THE AVERAGE OF SQUARES OF THE INSTANTANEOUS VALUES. INSTEAD OF HAVING THE FULL SINE WAVE TO AVERAGE WE ONLY HAVE THE PEAKS OF THE PULSES. FROM THE TABLES WE FIND THAT THE A.C. COMPONENT AT THE INPUT OF A 3 PHASE FULL WAVE FILTER IS ONLY .057 OF THE D.C. INPUT.

THERE IS 200 VOLTS DROP AT 5 AMPS IN THE FILTER REACTORS. THE RESISTANCE OF THE REACTORS IS GIVEN AS 40Ω IN PROBLEM 7. THEREFORE D.C. INPUT E IS $10,000 + 200$ OR 10,200 VOLTS AND AC COMPONENT IS $.057 \times 10,200 = 581$ VOLTS. WE MUST DESIGN THE FILTER SO THAT IT ATTENUATES 581 VOLTS TO 20 VOLTS.

$$\text{ATTENUATION FACTOR} = \frac{\text{AC OUTPUT}}{\text{AC INPUT}} = 20/581 = .0344$$

THE RIPPLE FREQUENCY OF 3 PHASE FULL WAVE IS 360 CYCLES.

$$\text{ATTENUATION FACTOR } .0344 = \frac{1}{(2\pi f)^4 L_1 L_2 C_1 C_2}$$

$$L_1 L_2 = \frac{1}{.0344 (2\pi f)^4 C_1 C_2}$$

THE USUAL ARRANGEMENT OF THIS TYPE OF FILTER IS TO HAVE THE INPUT INDUCTANCE SLIGHTLY LARGER THAN THE OUTPUT REACTOR. INPUT C IS USUALLY SMALLER THAN THE OUTPUT CAPACITY. SINCE BOTH SECTIONS MUST HAVE THE SAME F_C THEN EACH SECTION MUST HAVE THE SAME LC PRODUCT AND:

SOLUTION OF PROBLEM 8 POWER SUPPLIES

$$\begin{aligned}
 &L_1:L_2: :C_2:C_1 \\
 &L_1C_1 = L_2C_2 \\
 &C_1 = 1 \mu\text{F} \quad C_2 = 1.5 \mu\text{F} \\
 \text{THEREFORE} \quad &L_1:L_2: :1.5:1 \\
 &L_1 = 1.5 L_2 \\
 \text{AND} \quad &L_1L_2 = 1.5 L_2L_2 = 1.5 L_2^2 \\
 \text{SO} \quad &1.5 L_2^2 = \frac{1}{.0344 (6.28 \times 360)^4 1 \times 1.5 \times 10^{-12}} \\
 &= \frac{1}{.0344 (6.28 \times 360)^4 15 \times 10^{-13}}
 \end{aligned}$$

THE SIMPLEST METHOD OF SOLVING THIS PROBLEM IS BY LOGS. BY SLIDE RULE:

LOG 6.28	=	.798	
LOG 360	=	2.556	
ADDING		3.354	
		4	
RAISING TO 4TH POWER		13.416	
LOG .0344		-2.536	
LOG 15		1.176	
LOG 10 ⁻¹³		-13.000	
ADDING		0.128	LOG OF DENOMINATOR.
LOG OF 1	=	0.000	
LOG OF 1 ALSO	=	-1 + 1.000	
LOG OF DENOMINATOR		.128	
SUBTRACTING		-1.872	

ANTILOG OF .872 IS 745 AND -1 CHARACTERISTIC FIXES DECIMAL POINT.

$$\begin{aligned}
 1.5 L_2^2 &= .745 \\
 L_2^2 &= .745 \div 1.5 = .497 \\
 L_2 &= \sqrt{.497} = .7 \text{ HENRY} \\
 L_1 &= 1.5 L_2 = 1.5 \times .7 = 1.05 \text{ H.}
 \end{aligned}$$

$F_C = \frac{1}{\pi \sqrt{LC}}$ AND SINCE $L_1C_1 = L_2C_2$ EITHER SECTION CAN BE USED IN DETERMINING

F_C .

$$\begin{aligned}
 F_C &= \frac{1}{3.14 \sqrt{1.05 \times 1 \times 10^{-6}}} = \frac{1}{3.14 \sqrt{105 \times 10^8}} \\
 &= \frac{10^4}{3.14 \times 10.2} = \frac{10^4}{32} = 312 \text{ CYCLES}
 \end{aligned}$$

THEREFORE INPUT REACTOR IS 1.05 H AND INPUT C IS 1 μF . OUTPUT L IS .7 H. OUTPUT C 1.5 μF . THESE ARE THE SMALLEST VALUES THAT CAN BE USED AND STILL SATISFY THE CONDITIONS OF THE PROBLEM.

POWER SUPPLIES

Solution of Problem 9

Two tubes are used in a Class B amplifier with a plate voltage of 400 volts. The total plate current varies from 12 MA at no signal to 100 MA for full signal.

- (A) Determine the bleeder resistance that must be placed across the filter output if the range of variation for the total current supplied by the rectifier is 4 to 1. Assume zero voltage regulation for the rectifier and filter. Values must be calculated, not assumed; i.e. the current variation of 4 to 1 fixes the bleeder current value.
- (B) If a swinging choke is used as the first element in the filter, what should be its specifications?

Answer

- (A) Let I_b be the bleeder current in MA. Then the total no signal current = $I_b + 12$ and the total full signal current = $I_b + 100$. According to the conditions of the problem, solving for I_b

$$(I_b + 100) : (I_b + 12) = 4 : 1$$

$$I_b + 100 = 4(I_b + 12)$$

$$I_b + 100 = 4I_b + 48$$

$$4I_b - I_b = 100 - 48$$

$$3I_b = 52$$

$$I_b = \frac{52}{3} = 17.3 \text{ MA} = .0173 \text{ ampere}$$

$$\text{Bleeder resistance, } R_b = E/I_b = \frac{400}{.0173} = 23,100 \text{ ohms } \underline{\text{ans.}}$$

- (B) Total no signal current
- $$= I_b + 12 = 17.3 + 12$$
- $$= 29.3 \text{ MA}$$
- $$= .0293 \text{ ampere}$$

No signal load resistance with bleeder

$$R = E/I = \frac{400}{.0293} = 13,640 \text{ ohms}$$

Critical L of choke at no signal

$$= \frac{13,640}{1,000} = 13.64 \text{ henries}$$

Optimum L of choke at no signal

$$= 13.64 \times 2 = 27.28 \text{ henries } \underline{\text{ans.}}$$

POWER SUPPLIES
Solution of Problem 9

Total full signal current

$$\begin{aligned} &= I_b + 100 = 17.3 + 100 \\ &= 117.3 \text{ MA} = .1173 \text{ ampere} \end{aligned}$$

Full signal load resistance with bleeder

$$R = E/I = \frac{400}{.1175} = 3,410 \text{ ohms}$$

Critical L of choke at full signal

$$= \frac{3,410}{1,000} = 3.41 \text{ henries}$$

Optimum L of choke at full signal

$$= 3.41 \times 2 = 6.82 \text{ henries} \quad \underline{\text{ans.}}$$

Thus the specifications of the swinging choke should be 27 henries at 30 MA and 7 henries at 120 MA. ans.