



SECTION 3

**SPECIALIZED BROADCAST
RADIO ENGINEERING**

TECHNICAL ASSIGNMENT

POWER AND CONTROL CIRCUITS FOR BROADCAST TRANSMITTERS

Copyright 1947 by
Capitol Radio Engineering Institute
Washington, D. C.

311D

- TABLE OF CONTENTS -
 TECHNICAL ASSIGNMENT
 POWER AND CONTROL CIRCUITS
 FOR BROADCAST TRANSMITTERS

	Page
HIGH VOLTAGE PLATE SUPPLY RECTIFIER	1
GRID BIAS RECTIFIERS	5
POWER SUPPLY, OSCILLATOR-AMPLIFIER UNIT	7
POWER SYSTEM	12
CONTROL CIRCUIT	15
CONTROL POWER SOURCES	16
OSCILLATOR-AMPLIFIER FILAMENT CONTROL	17
WATER SYSTEM AND POWER AMPLIFIER FILAMENT CONTROL	17
RECTIFIER FILAMENTS, BIAS PLATE AND BIAS DELAY CONTROL	18
OSCILLATOR-AMPLIFIER BIAS AND PLATE CONTROL	19
POWER AMPLIFIER BIAS CONTROL	20
POWER AMPLIFIER PLATE VOLTAGE CONTROL	20
POWER AMPLIFIER OVERLOAD TRIPPING CIRCUIT	22
REDUCED POWER CONTROL	23
POWER INTERRUPTION	23
RADIO FREQUENCY PROTECTIVE CIRCUIT	25
STARTING PROCEDURE	26
CONTROL APPARATUS	28
MANUALLY OPERATED SWITCHES	29
CIRCUIT BREAKERS	29
CONTACTORS, POWER RELAYS	35
SENSITIVE RELAYS	37
TIME DELAYS RELAYS	39
SERVICING SWITCHES, BREAKERS AND CONTACTORS	42
INDUSTRY ACKNOWLEDGEMENT	44

POWER AND CONTROL CIRCUITS FOR BROADCAST TRANSMITTERS

This discussion will be devoted to an examination of the power supplies and power control circuits of typical modern high power broadcast transmitters. Those selected are typical of excellent design and a thorough understanding of the functions of each part of the circuit should enable the engineer quickly to diagnose the operation of any such circuits in other transmitters of comparable power output. The principles of operation will apply also to lower power transmitters but to a simplified degree, because in transmitters of lower power output there will be fewer stages of amplification to require power and protection, less elaborate water or air circulating systems, and less probability of extensive damage if circuit functioning is not perfect.

The function of the power supply circuits is to furnish plate and filament power at the proper voltage to each tube in the radio and audio frequency chains and the proper negative grid bias at each tube where a bias is required. The power to each stage must have proper regulation, be adequately filtered to remove ripple components, and usually the voltage to each transmitter unit must be variable over a reasonable range to allow correct adjustments for maximum tube life, proper power output and operating efficiency. In modern transmitters the tube filaments ordinarily are heated by alternating current obtained from step-down transformers. Plate and bias voltages are obtained from rectifiers, usually of the mercury-vapor type.

The functions of the control circuits relate to starting and stopping the transmitter, either automatically or manually by sections, and to protecting the various parts of the transmitter against damage due to breakdown or failure of any circuit component. A principal function of the control circuit also is that of protecting the operating personnel from possible contact with dangerous

voltages.

Starting a high power transmitter involves a great deal more than simply closing a switch and applying plate, filament and bias voltages. For example, in the mercury vapor rectifiers it is necessary that the tubes heat up to some extent before anode voltage is applied in order that the internal voltage drop be low enough to protect the filament from injury by molecular bombardment. It is essential in the water-cooled tubes that proper water circulation be established before the filaments assume operating temperature. Provision must be made so the plate potential of the power amplifiers cannot be applied until the amplifier tube filaments reach the proper operating temperature and until the proper negative bias is applied. It is essential that plate voltage be removed instantly in the event of a serious flash-over in a tube or circuit component but it is also essential that power be reapplied without delay in the event such flash-over is not the result of serious and permanent breakdown of a circuit component, in order to avoid unnecessary time off the air.

It further is essential that in the event a door or window into a transmitter compartment is opened by the engineer for any purpose, the power must be automatically removed from the transmitter for the protection of the engineer. Further details of the control system involve a warning to the engineer if the water-cooling system fails to function and the water temperature becomes excessive; a means of determining whether or not the resistance of the water column is sufficiently high; indicating lights on the control panel to enable the operator to know instantly the part of the circuit in which trouble occurs, etc.

HIGH VOLTAGE PLATE SUPPLY RECTIFIER

Figure 1 shows the schematic circuit diagram of the 18,000 volt rectifier in the W.E. 50 K.W. Broadcast Transmitter Type 407-A which supplies plate voltage for the four water-cooled tubes, two 232 B's in the modulating amplifier and two 298 A's in the high efficiency power amplifier. Six mercury-vapor tubes are used, with a seventh mounted in a spare socket and operated with reduced filament voltage at all times when the rectifier is in operation. Connections to all anode and filament output terminals are through switches. In the event of rectifier tube failure only a few seconds

are required to throw the switches which will cut out the defective tube and connect into service the spare tube which is already warmed up and ready for operation. Included in the switching

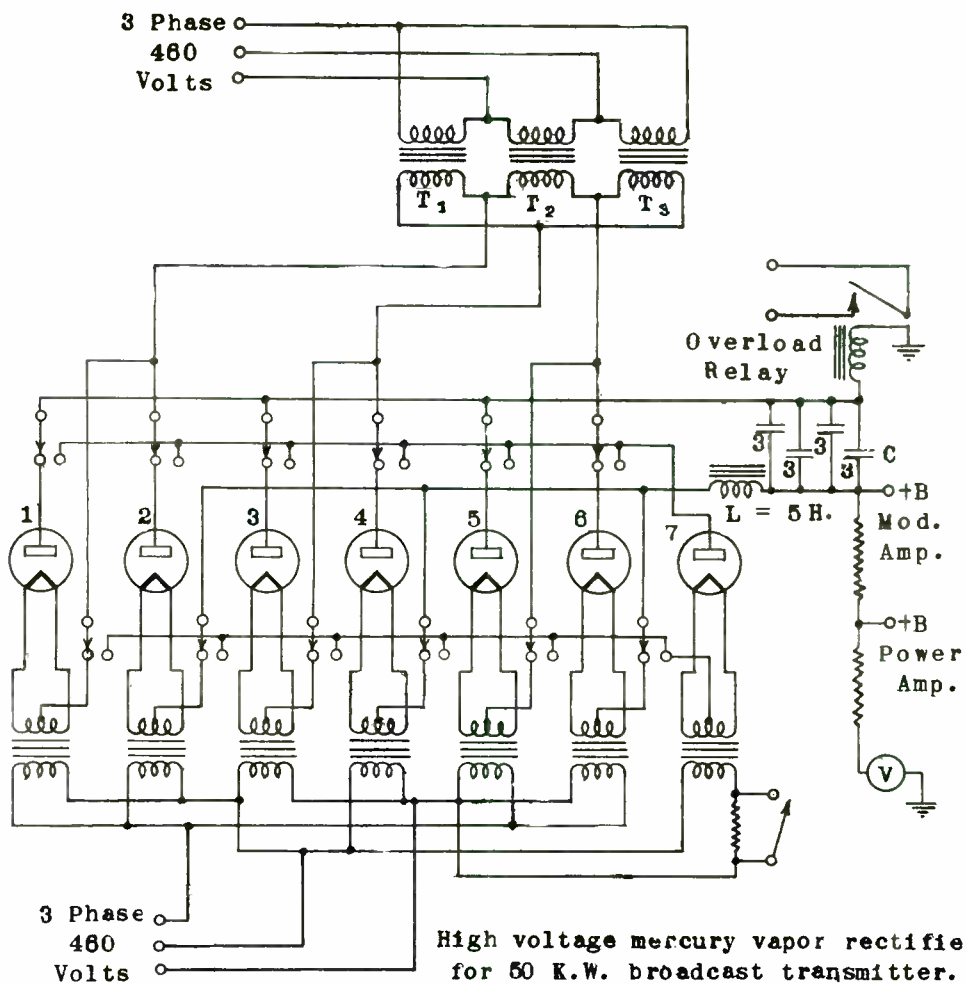

Fig. 1.

arrangement is one which shorts out the dropping resistor to allow the substituted tube to operate at correct filament voltage. The switching arrangement is clearly shown in the diagram. The tubes are W.E. Type 255 B mercury-vapor rectifiers.

The circuit employed is a three phase full-wave bridge type in which two tubes are in series during each alternation. (The student is referred to an earlier lesson on rectifiers for details of the circuit operation.) T_1 , T_2 and T_3 are the three high voltage

single phase transformers, each rated at 75 K.V.A. Both primary and secondary windings are delta connected to form a three phase transformer. Each primary winding is rated at 565 volts and each secondary at 14,500 volts.

To obtain maximum tube life from mercury-vapor rectifiers it is necessary to carefully control the filament voltage, room temperature and the phase relation between filament voltage and anode current. The filament transformers are delta-connected, two in parallel in each leg, across a closely regulated 3 phase 460 volt circuit. Taps are provided on each primary for adjusting the filament voltage of each tube to the nearest value to 5 volts. It is recommended that the room temperature be maintained at 70° or higher. At a lower temperature the voltage drop within the tube rises and increases the deactivation of the filament due to molecular bombardment.

In the normal installation the phase relation of filament voltage and anode current is such that the filament voltage of each tube undergoes a reversal in the middle of the anode conduction period of that tube. This allows the anode current flow in the filament to reverse periodically and to flow in both sides of the filament for equal periods of time. While this would be relatively unimportant in small inexpensive tubes, it is a definite factor to be considered in tubes where the anode current is an appreciable percentage of the filament current and where the tube cost is relatively high.

The output filter consists of a 5 Henry choke (L) and four 3 μ F condensers in parallel. The low potential side of the output connects to ground through an overload relay. In the event of serious overload the closing of this relay functions to open the high voltage circuit breaker which removes primary power from the high voltage transformers T₁, T₂ and T₃ but not from the filament transformers.

In the anode circuit of each rectifier tube is a relay which functions to energize a lamp on the control panel to indicate an arc-back failure of the tube. The arrangement is shown in Figure 2. R is a resistance of sufficient value that a current in the order of the anode current of the rectifier tube will produce a voltage across it sufficient to actuate the relay. The normal output current is pulsating d.c. and of such polarity that no current flows in the copper oxide rectifier Cu and hence no current flows

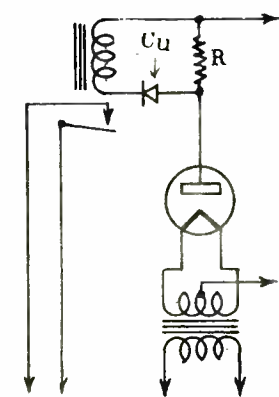

Arc-back indicator
relay.

Fig. 2.

through the relay winding. When an arc-back occurs alternating current flows through the tube and hence through R. The copper oxide rectifier becomes conducting on the reverse alternations and current flows through the relay winding, the relay closes and energizes a relay in the control panel which in turn lights an indicating lamp to notify the operator which tube is arcing back. The operation of the relay and the copper oxide rectifier may be checked by momentarily connecting five volts from the filament transformer across R. Anode potential is removed during this test. The operation of the relay rectifier itself may be checked by connecting a 4 to 6 volt battery across R. The relay should operate when the positive terminal of the battery is connected to the anode end of R and should not operate when the connection is reversed.

GRID BIAS RECTIFIERS

Three grid bias rectifiers are employed in the 407-A transmitter and are shown schematically in Figure 3. Rectifier 1 supplies negative bias in the order of -1250 volts for the peak output tube in the high efficiency power amplifier. The circuit employed is three phase half-wave with transformer T_1 supplying the anode voltages. The primary windings of T_1 are tapped so that variation of the output voltage can be obtained. A single filament transformer supplies 2.5 volts for the filaments of the Type 249 B tubes. The primary of this transformer is tapped and should be adjusted to the nearest filament voltage of 2.5 volts. The filter consists of choke L and two 25 μF condensers in parallel.

Rectifier 2 is similar to Rectifier 1 except that the plate transformer is designed for d.c. rectifier output of -500 volts as bias for the carrier tube in the high efficiency power amplifier. The primary windings of T_2 are tapped and normally should be adjusted for output voltage of -500 volts. The filter is similar to that of Rectifier 1. The filament transformer of Rectifier 2 is similar to that of Rectifier 1. In both of these rectifiers the filter condensers CC and C_1C_1 are installed in the power amplifier unit.

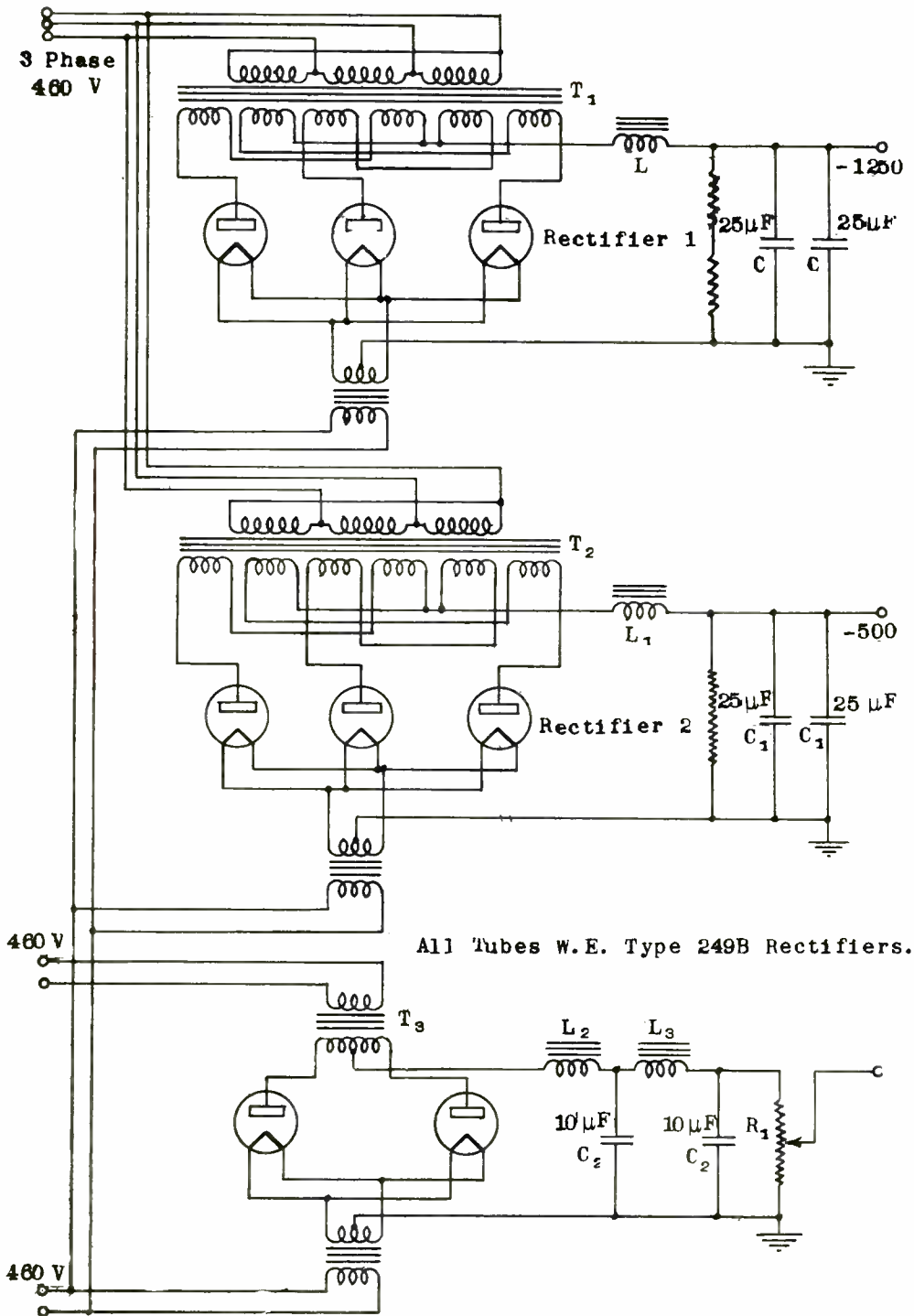

Fig. 3. Grid Bias Rectifiers for 50 KW Broadcast Transmitter.

Rectifier 3 employs a single phase full-wave circuit to supply approximately -600 volts as bias for the two Type 232 B tubes in the modulating amplifier. A two section filter $L_2C_2L_3C_2$ removes the ripple component and potentiometer R_1 allows some adjustment of the bias voltage.

The tubes employed in all rectifiers of Figure 3 are Type 249 B. Rectifiers 1 and 2 operate from a 3 phase 460 volt supply which has been carefully regulated, as also is the single phase input voltage to Rectifier 3 and the single phase supply to all filaments. Voltmeters are provided on the control unit for indicating each of the bias voltages.

POWER SUPPLY, OSCILLATOR-AMPLIFIER UNIT

The low power unit of the 407-A transmitter includes the crystal oscillator, three R.F. amplifier stages, and the audio amplifiers. The plate and screen voltages for all of these stages are taken from a duplex single phase full-wave rectifier which employs four 249 B tubes in a unique circuit. A fifth tube is incorporated as a spare and may quickly be substituted for any one of the four operating tubes which may fail in service. The lower voltages required for the smaller tubes are obtained from potentiometers associated with the rectifier output. Two 2 section filters are employed: The output through one filter supplies plate voltage for the last two audio amplifier stages; the output through the second filter supplies plate and screen voltage to the first audio amplifier, screen voltage for the second audio amplifier, plate voltage for the oscillator, and plate and screen voltages for the low power R.F. amplifiers. The arrangement of this rectifier is shown in Figure 4.

This is an interesting circuit in that it consists of two rectifiers in one. The upper filter takes the voltage from only one-half of the secondary of T_1 on each alternation. On one alternation the circuit is from the positive side of the filter LC, into the center of the high voltage secondary winding, through the left end of the winding, from filament to anode in Tube 1 and to ground. On the next alternation, the circuit is through the right half of the secondary winding, from filament to anode of Tube 4, to ground. Thus the output of this filter represents the output of Tubes 1 and 4

and at a voltage of one-half the high potential winding.

The output of filter L_1C_1 is at higher potential. On one alternation the circuit is from the positive filter terminal through

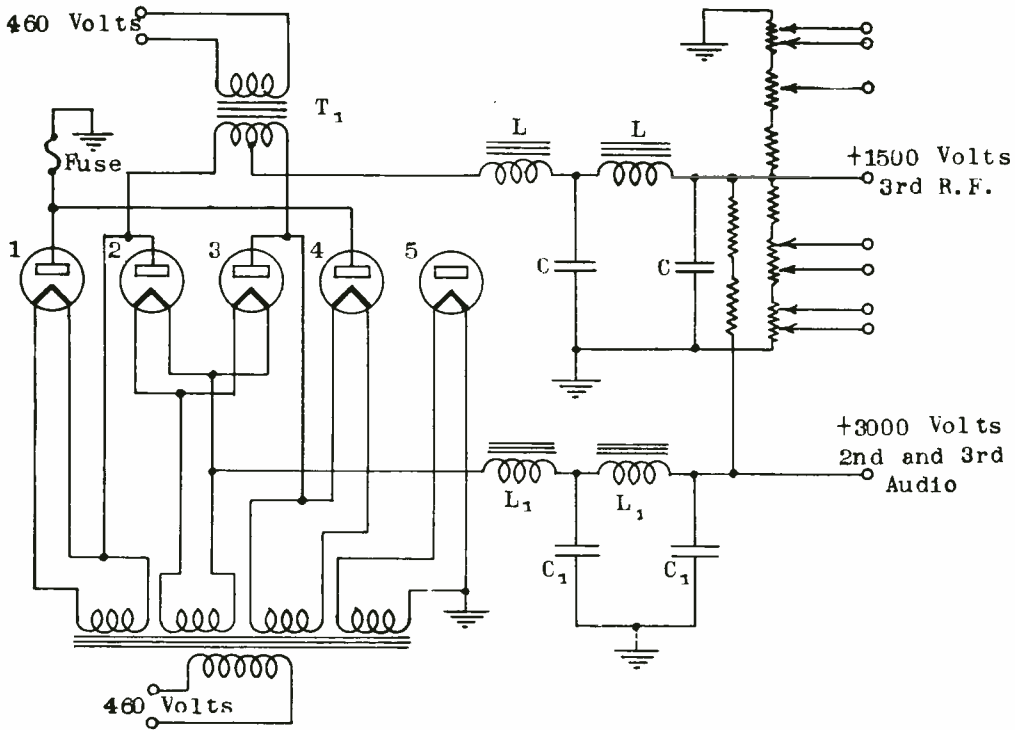
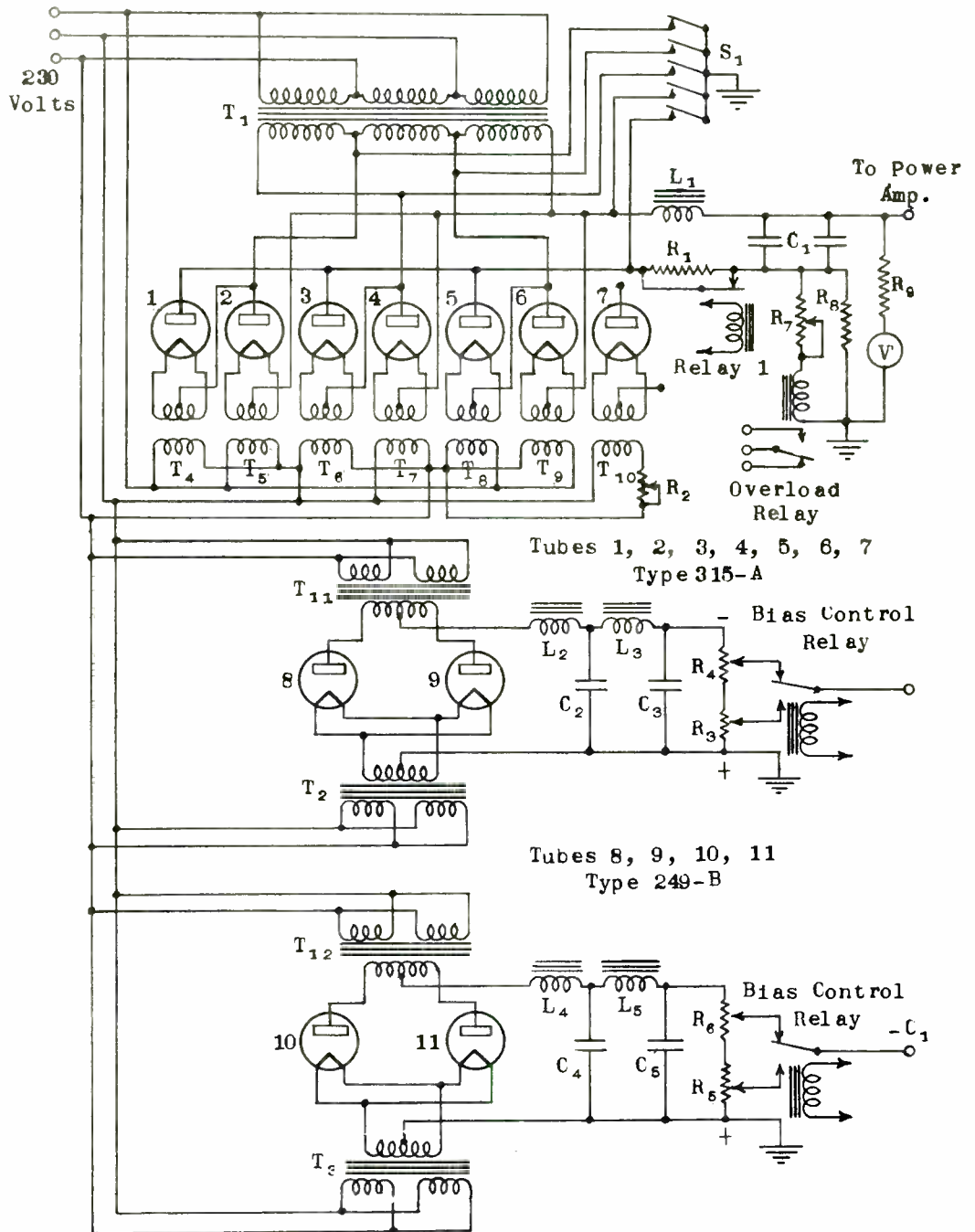

Fig. 4.

the filter, from the filament to anode of Tube 3, through the entire high voltage winding from right to left to the filament of Tube 1, to anode of Tube 1, to ground. On the next alternation, the current flow is from filament to anode in Tube 2, through the entire secondary winding from left to right, from filament to anode in Tube 4, to ground. Thus in this rectifier the applied transformer voltage is double that of the two tube rectifier of filter LC, and two tubes are connected in series in each alternation to double the peak inverse voltage rating of the rectifier.

Figure 5 illustrates (top) the power amplifier plate supply rectifier and (below) the two power amplifier grid bias rectifiers of the W.E. 5 K.W. Type 405-A-1 broadcast transmitter.

The circuit of the plate voltage rectifier is quite similar to that of Figure 1 except that smaller tubes (Type 315-A) are used. Power is supplied to plate transformer T, and filament transformers T_4 to T_{10} inclusive from a 230 volt three phase source,



High Voltage Rectifier for Power Amplifier and Two Grid Bias Rectifiers for 5 KW Broadcast Transmitter.

Fig. 5.

the rectifier employing a conventional three phase full wave circuit. Between the negative rectifier terminal and filter capacity C_1 is connected R_1 . Before plate voltage is applied the short-circuiting contacts across R_1 are open and R_1 prevents too-sudden application of high voltage across C_1 . When C_1 has had time to charge Relay 1 closes the contacts short-circuiting R_1 .

The low potential side of the rectifier and filter connects to ground through R_8 across which is connected the plate overload relay. When plate current is excessive, the IR drop across R_8 is increased to the point where the overload relay functions to remove plate voltage from the rectifier. Adjustment of the relay operating point is done by varying the resistance of R_7 .

Switch S_1 is operated by the hand wheel by which the door into the transmitter enclosure is opened. Opening the enclosure door removes power from the transmitter and simultaneously, by means of S_1 , grounds both sides of the power supply filter and each section of the secondary of the high voltage transformer.

In Figure 5 immediately below the high voltage rectifier are the two grid bias rectifiers for the two tubes in the high efficiency power amplifier. These single phase, full-wave rectifiers are conventional in every respect except that, since a negative voltage is to be supplied, the positive side is grounded.

The Type 405-A-1 transmitter is designed for operation at 5 K.W., 2.5 K.W. and 1 K.W. output. For power output of less than 5 K.W. the bias on each of the power amplifier tubes must be reduced. This is done by means of the two "Bias Control" relays. In the relay positions shown the higher 5 K.W. bias is provided. In the alternate relay position the lower bias for reduced power output is provided. Actual adjustment for the proper bias in each position is provided by potentiometers R_3 , R_4 , R_5 and R_6 .

Reduction in power amplifier plate voltage for reduced power is accomplished by changing the terminal connections on transformer T_1 to provide a lower turns ratio.

Figure 6 illustrates portions of the high voltage rectifier circuit of Figure 5. To the left in Figure 6 is T_1 Figure 5. In the center is the filter reactance L_1 . At the right is C_1 together with R_1 and the switch assembly of Relay 1. The tubular plate voltmeter multiplier of Figure 6 is R_9 in Figure 5.

In the Type 405-A-1 transmitter plate voltage for the lower

High Voltage
Plate Transformer
(3 Single Phase
Transformers in one
Case—Asbestos Filled)

Busses to High Voltage
Rectifier and
Power Amplifier

High Voltage Filter
Retard Coil (Non-
Inflammable
Oil-Filled)

Automatic Voltage
Regulator
(Air Cooled)

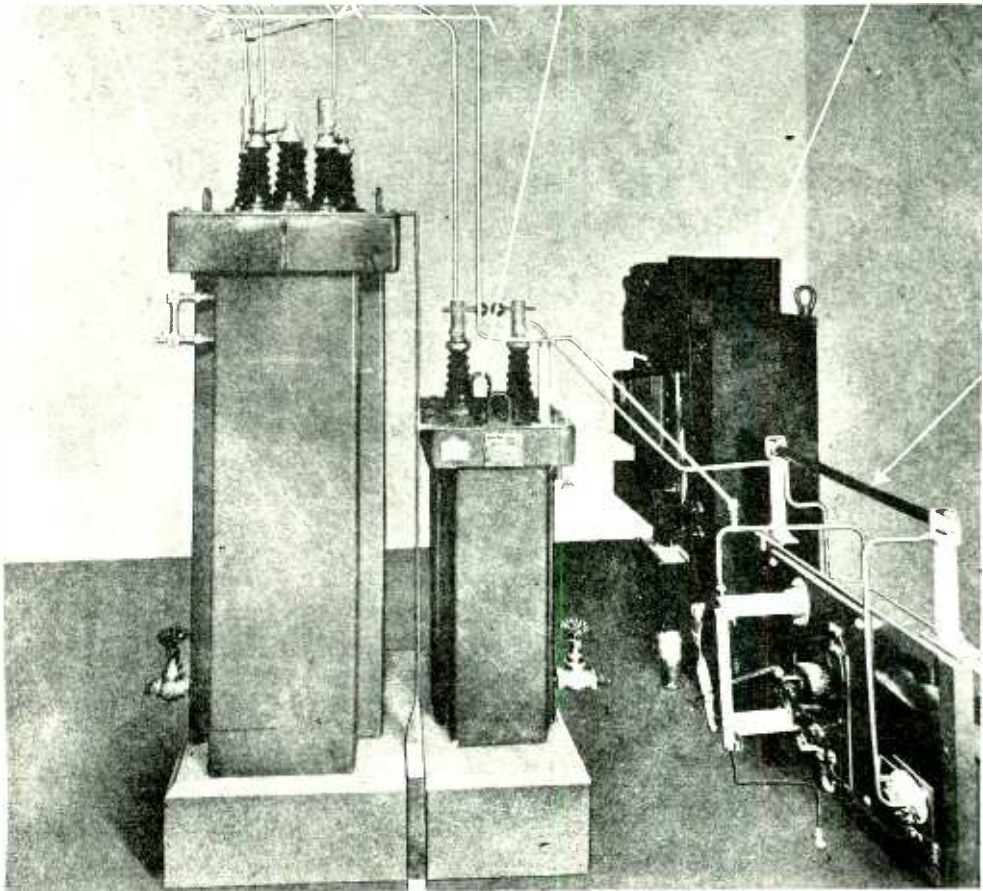

Tubular
Plate
Volt-
meter
Multi-
plier

High
Voltage
Filter
Con-
denser
and
Charging
Switch
Assembly

Power Apparatus Assembly adjacent to rear of Radio Transmitter Units Assembly

Fig. 6.

power R.F. stages preceding the power amplifier and the audio stages is furnished by a four tube mercury-vapor rectifier similar to that in Figure 4.

Included in the power equipment of the transmitter are the step-down transformers which furnish filament current for the vacuum tubes and the motor which drives the water pump (or the blower motor if forced air cooled power amplifier tubes are used).

The rectifier units described above are typical of the plate and bias voltage supplies used in all high quality broadcast transmitters. The types of tubes employed, the style of transformers, condensers and chokes, and the actual arrangement of the apparatus

will vary in different transmitters; basically all are quite similar.

POWER SYSTEM: The Western Electric 405A-1 radio broadcast transmitter has been selected as typical of excellent modern design for description of the power distribution system and control circuit for a 5 kilowatt transmitter. It might be added at this point that in the case of the power system and control circuit of the 50 kilowatt transmitter manufactured by this company, the general arrangement, except for the provision for handling higher power, is essentially the same as for the 5 kilowatt transmitter being described. Figure 7 is the schematic arrangement of the power distribution system and Figure 8 shows the schematic arrangement of the control circuit.

In re-drawing these diagrams from those supplied by the manufacturer the same letters designating types of apparatus have been retained. Those applying to these diagrams are shown in Table 1.

TABLE 1.

Letters Designating Types of Apparatus:

- BL - Bell
- CB - Circuit Breakers
- D - Switch
- WD - Water Relay
- E - Indicator or Meter Lamp
- F - Fuse
- K - Key (Switch)
- M - Meter
- MB - Motor Blower
- MP - Motor Pump
- R - Resistance
- S - Relay (or contactor)
- T - Transformer or Regulator
(as indicated)
- TD - Water Temperature Alarm
- X - Rectox Rectifier
- W - Door Lock

Figure 7 illustrates the "power distribution system," the schematic arrangement of circuits by which main power is supplied to the various parts of the transmitter. This system may be divided into several units: Unit 1 is the power distribution panel on which are mounted a number of circuit breakers and relays. These

circuit breakers and relays provide the first protection of the power supply against major breakdown of apparatus in any component part of the transmitter. Unit 2 is shown at the left, and is a motor controlled voltage regulator which automatically maintains a voltage of 230 volts plus or minus 1 percent on the busses through which power is supplied to the various transmitter components, provided that the supply voltage remains within the limit of 205-250 volts, and there are no rapid variations within those limits. In other words this voltage regulator will compensate for normal fluctuations of the main power line due to changes in load FROM OTHER SOURCES. Unit 3 is the pump for the cooling water system and the motor blower which operates in conjunction with the water-cooling radiator. Unit 4 shown on the right is the three phase plate transformer for the high voltage rectifier, and Unit 5 at the extreme right is the rectifier unit itself, that is, the arrangement of rectifier tubes and filament transformers.

Power enters the transmitter through circuit breaker CB1P at 230 volts, 3 Phase 60 cycles. Through CB11P the three phase input voltage goes to a voltmeter on the control panel where, by means of a simple switching arrangement, each phase of the line voltage on each side of the regulator can be measured. Also after passing through CB1P the input voltage is applied to the terminals of the voltage regulator, and after regulation, it passes on to the main busses for distribution to the component parts of the transmitter.

The motor circuit of the voltage regulator is supplied through CB2P. Through CB3P power is supplied to the control circuit by means of which all power applications, starting and stopping, protection, etc. are effected.

Through CB4P and relay S2P power is applied (through a step-down transformer, of course) to the filaments of the radio frequency power amplifier tubes. CB5P is a spare circuit breaker. Through CB6P and relay S5P power is supplied to the water pump and forced-air blower motor.

Through CB7P and relay S3P power is supplied to the oscillator-amplifier unit. This unit is really the entire low power end of the broadcast transmitter, containing the crystal-controlled oscillator, buffer amplifiers, modulated amplifier, speech amplifiers and modulator. The unit also contains its own filament transformers,

plate voltage and negative bias rectifiers, etc. Thus, through the protective arrangement shown the lower power portion of the broadcast transmitter functions as a single unit.

Through CB8P and relay S4P the anodes of the bias rectifiers for the power amplifier are energized. These rectifiers are similar to those shown in the lower section of Figure 5.

Through CB9P and relay S6P voltage is applied to all rectifier filaments. In a portion of the control circuit not shown in Figure 7 provision is made for applying plate voltages at a required time interval later than the application of filament voltages to the rectifiers. Mercury vapor rectifier tubes are used throughout in this transmitter, and this warming up period is essential in order to allow the mercury to vaporize and lower the tube resistance before anode voltage is applied.

CB10P is a motor driven circuit breaker by means of which power is supplied to the plate transformer (T1P) of the high voltage rectifier. By means of additional apparatus mounted in the control unit provision is made for automatic reclosure under certain conditions of temporary overload, so that in the case of a flashover in the rectifier tubes CB10P will open, but almost instantaneously after the circuit is broken will reclose and operation of the transmitter will be resumed. Flashover and temporary overloading are not uncommon in high voltage rectifiers and high power amplifiers, and while it is necessary that protection be provided against such conditions it is highly desirable that after the arc, due to the flashover, has been broken that power automatically be re-applied at once so that the break in the program is only for an instant. Of course further protection is provided in case of real failure of apparatus.

The connection to T1P after the circuit has passed through CB10P is interesting. Each of the three wires connects directly to the top end of one of the three phase primary windings. When relay S7.1P is closed in the position shown it connects power to a tap near the lower end of the primary of each phase of the transformer. In this condition the maximum number of primary turns are used and hence the secondary-primary turns ratio is low, and the secondary voltage is reduced. As shown, during this condition relay S7.2P is open.

When the engineer at the control panel throws the power control

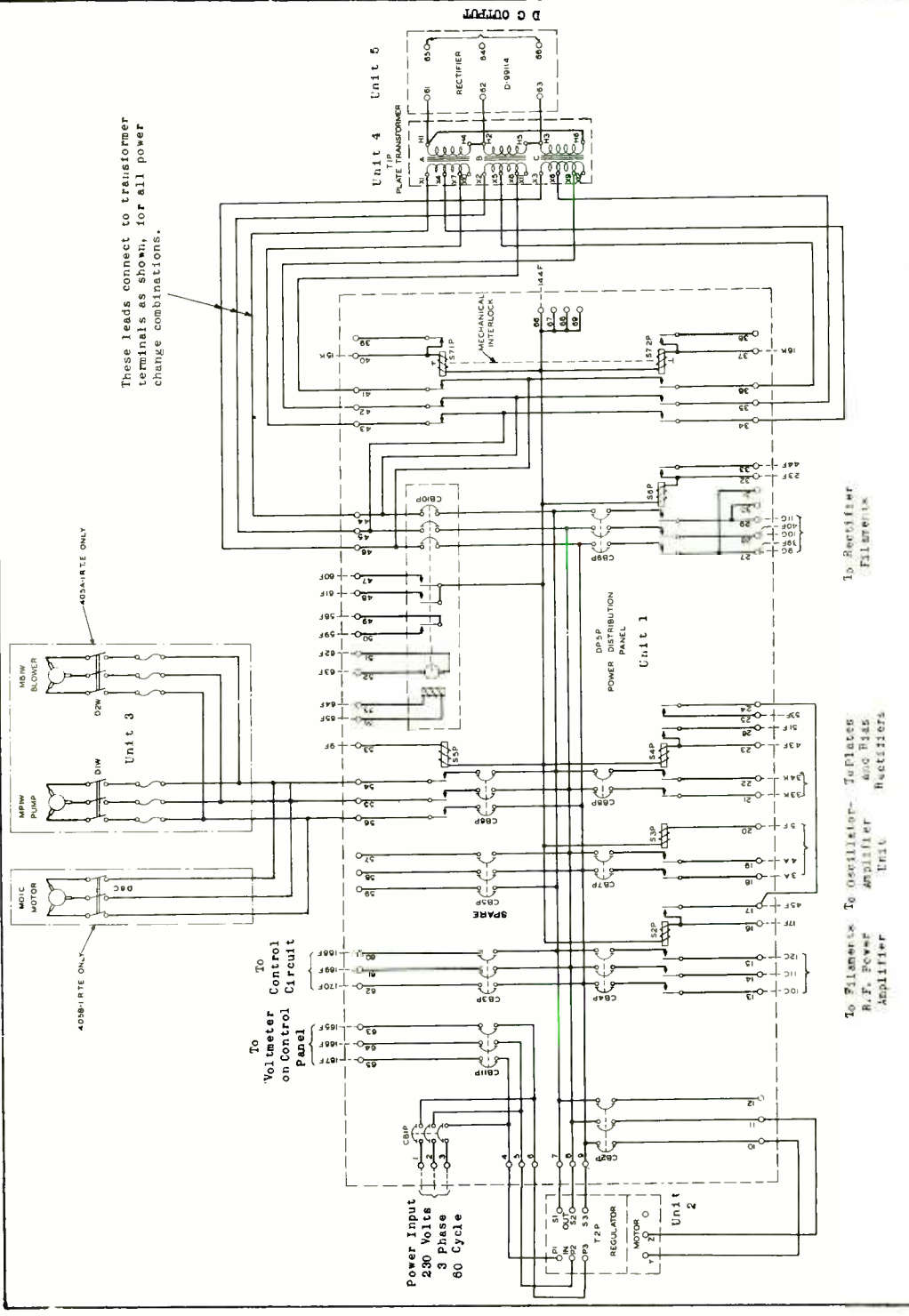

To Rectifier
Filaments
To Filaments
To Oscillator- Tubes
R.F. Power Amplifier
and Bias Rectifiers
Applifier Unit

Figure 7. Schematic of Power Distribution System, Western Electric Type AC5A-1 Broadcast Transmitter

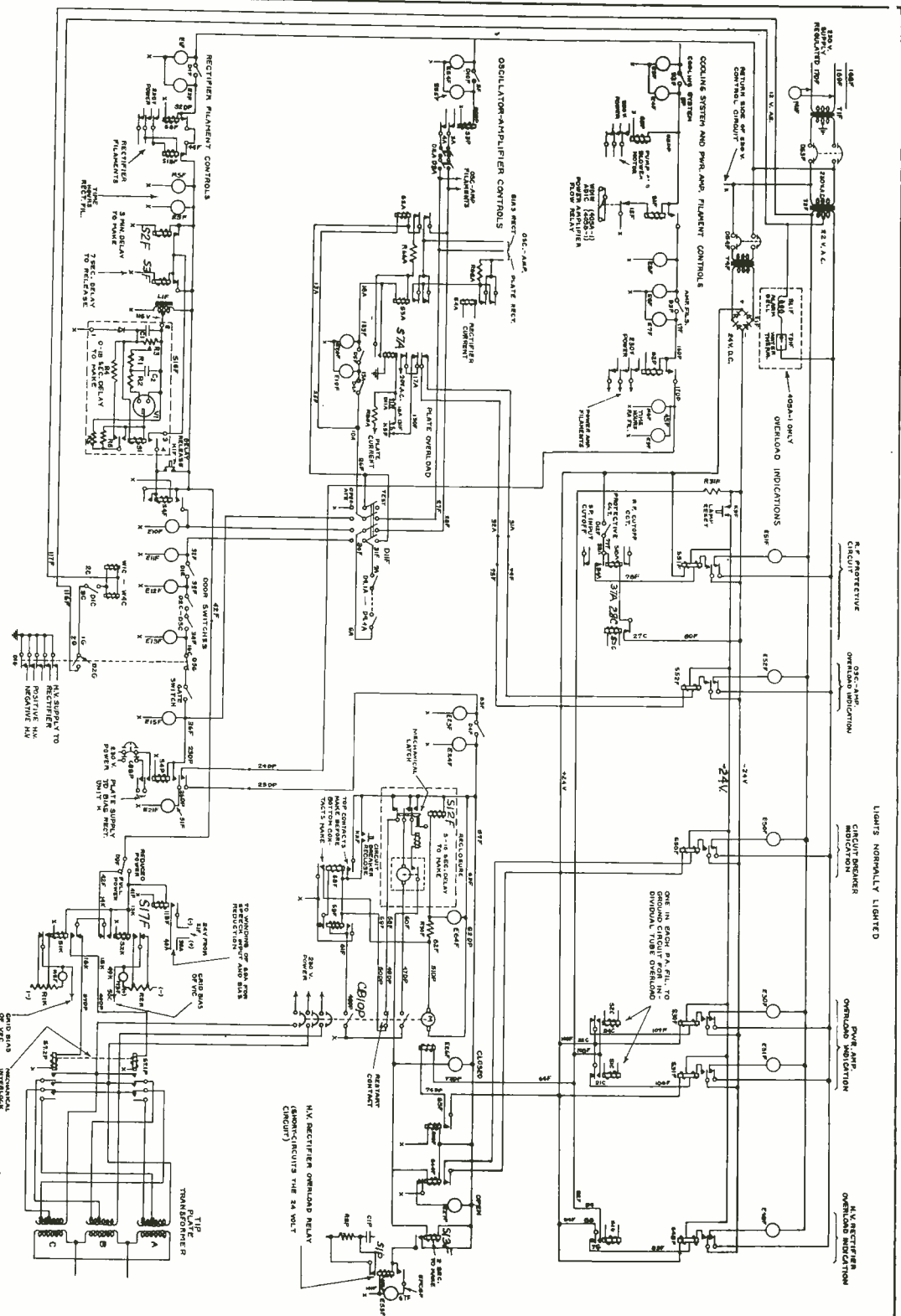

Figure 8. Schematic Diagram of Control Circuit, Western Electric Type 405A-1 Broadcast Transmitter

switch to "high power" S7.1P opens and S7.2P closes. During this second condition, as can readily be seen from the diagram, fewer primary turns are connected into the circuit, the secondary - primary turns ratio is higher and the anode voltage applied to the high voltage rectifier is increased. This results in the application of higher voltage to the power amplifier tubes and permits greater power output from the transmitter. S7.1P and S7.2P are provided with a mechanical inter-lock, so that both cannot be closed simultaneously.

The power distribution panel enables the circuits which have separate functions in the operation of the transmitter to be isolated through individual circuit breakers, and also provides a systematic method of delivering the power to the circuit components from the input power line. The circuit breakers themselves provide overload protection for their individual circuits. Starting, stopping, and other types of protection are provided by means of a somewhat elaborate circuit of inter-locking relays and switches as will be shown in the control circuit.

CONTROL CIRCUIT: The schematic arrangement of the control circuit in the transmitter under consideration is shown in Figure 8. In order to study this figure intelligently it is necessary to know something of the unit arrangement of the transmitter as a whole. The letters assigned to the units and assemblies of apparatus are: Unit A, oscillator-amplifier; Unit C, power amplifier; Unit F, control unit; Unit G, high voltage rectifier; Unit K, bias rectifiers; Unit P, power apparatus; Unit W, water system. Thus, in Figure 8 where a relay is designated, for example as S1K it is located in the K unit which contains the bias rectifiers. Relay S3F is located in Unit F which is the control unit. Relay S6P would be found in Unit P which is the power system as shown in Figure 7. Thus, in apparatus designations the first letter refers to the type of apparatus, that is, D for switch, E for indicator or lamp, S for relay, M for meter, etc. The figure following the letter refers to the number designation of that piece of apparatus in the transmitter; the final letter refers to the unit of the transmitter in which that particular piece of apparatus is actually located.

Thus, while the control circuit of Figure 8 is shown as one schematic diagram, actually it is a somewhat elaborate circuit

which connects back and forth through all parts of the transmitter. Each piece of control apparatus is located where it will most easily and most efficiently perform its particular function in the control of the transmitter. If at any time it should become necessary to disconnect any of the control apparatus for repairs it is essential that RECONNECTION BE EXACTLY CORRECT otherwise some part of the starting or stopping sequence may be disturbed, or some protective function of the circuit may be voided.

CONTROL POWER SOURCES: Three sources of power are available for operation of the control apparatus. In the upper left corner of Figure 8 the primary power source for all control operations is brought into the circuit. This primary source is one phase of the 230 volt line from the voltage regulator (see Figure 7). M1F is the voltmeter by means of which any phase of the power source of either side of the voltage regulator may be checked. 230 volts are applied to the control circuit through T1F, a 1:1 ratio transformer which is used simply to allow the center tap connection of this phase to be grounded. Following T1F is a manually controlled circuit breaker D53F by means of which the entire control circuit can be isolated from the power source.

Following D53F the 230 volts goes to two terminals, one of which connects directly to the several major branches of the control circuit, and the other which is marked x, represents the return side of the many portions of the control circuit that are so designated throughout Figure 8. Also following D53F is a step-down transformer T2F which provides 22 volts A.C. for operation of a number of overload indicator lamps, 10 volts A.C. for operation of a water temperature alarm bell, and 12 volts A.C. for operation of a protective circuit through a door lock as shown in the lower center of Figure 8.

Also following D53F is a manually operated circuit breaker D54F which connects through step-down transformer T4F to the Rectox rectifier X1F to provide 24 volts d.c. for the operation of certain control relays which will be explained later in this discussion.

It might be stated in general that the major power control relays, that is, those which play a major part in the actual turning on and off of power throughout the transmitter, are heavy power operated 230 volt contactors. The relays whose primary function is that of turning on and off indicator lamps primarily in connec-

tion with overload and protective circuits are smaller 24 volt d.c. operated relays. Other relays function directly in the plate return circuits of the intermediate and power amplifiers to furnish overload protection for the vacuum tubes and associated equipment.

Neglecting, for the time being, the overload protection circuit, the basic control circuit which has to do with the sequence of starting, stopping, restarting after overload, etc., can be divided into three primary branches: First, the cooling system and power amplifier filament controls which take power from the 230 volt bus through switch D2F (upper left); the oscillator-amplifier controls which take power from the 230 volt bus through D10F (left center); third, rectifier filament controls which take their power from the 230 volt bus through switch D1F (lower left). Each of these three primary circuits controls a basic portion of the starting-stopping sequence, and all three are so inter-locked that the application of power to the various components of the transmitter is made in the proper sequence.

OSCILLATOR-AMPLIFIER FILAMENT CONTROL: Closing D10F energizes contactor S3P which supplies 230 volt power through switches D2A and D3A (which normally are closed) to the step down filament transformers in the oscillator-amplifier unit. Included in the oscillator-amplifier unit are the low power RF tubes, the speech amplifier tubes and the rectifier tubes in the low power plate bias and rectifiers. By means of certain time delay devices which will be explained later, this permits the filaments of all the tubes in the low power section of the transmitter to warm up before the application of anode or plate potential.

WATER SYSTEM AND POWER AMPLIFIER FILAMENT CONTROL: Closing D2F operates contactor S5P and supplies power to the water circulating pump and radiator blower motor. (In this transmitter the water is circulated through a radiator which is equipped with a blower to provide adequate cooling of the circulated water).

Closing D2F also supplies 230 volts to a contact and to one side of the coil of relay S1F. The other side of this coil is connected to a contact of the water-flow relay WD1W in the water cooling system of the power amplifier. After the water circulating pump has started WD1W operates by the water-flow and the circuit of S1F is completed to the return side. When S1F operates the control circuit is continued through the contact of S1F to switch B-11

D3F which is normally closed to the power amplifier filament transformers. Thus, the filaments of the power amplifier tubes cannot be energized until the proper flow of cooling water through the tube water jackets are established. Power actually is applied to the amplifier tube filaments by the closing of contactor S2P which, if D3F is closed, operates immediately when relay S1F operates.

RECTIFIER FILAMENTS, BIAS PLATE AND BIAS DELAY CONTROL: Closing D1F (lower left) supplies 230 volts to operate contactor S6P which energizes the rectifier filaments. When power is applied to the rectifier filaments by S6P one phase of the 230 volt filament power supply energizes relay S18F through which the control circuit proceeds to further apparatus which, in due time, applies anode potential to the rectifiers. With this arrangement the lower branch of the control circuit definitely is open until power is actually applied to the rectifier filaments so there is no possibility of applying anode potential to the rectifiers before power is applied to the filaments.

The 230 volt circuit is continued through the auxiliary contacts of S6P and the contacts of S18F. Immediately beyond S18F is M5F which indicates the operating time in hours of the rectifier filaments, and the indicator lamp E5F which notifies the control engineer that the rectifier filaments are on.

The operation of S18F also energizes delay relay S2F, and through auto-transformer L1F 115 volts is applied to terminals 1 and 2 of relay S16F. S16F controls the reheating of the rectifier tubes in the case of power failure. A description of its operation will be given later. Under original starting conditions S16F will operate, closing the contacts connected to terminals 3 and 4 about 18 seconds after S16F is energized. Three minutes after S2F is energized its contacts close and operate S3F. The control circuit continues through the contacts of S2F and S3F in parallel, then through the contacts of S16F to relay S4F which locks itself up from a point on the control circuit ahead of the contacts of S2F. A momentary-contact push button K1F is bridged from ahead of the S2F contacts directly to S4F and this pushbutton (K1F) may be used to operate S4F instead of waiting for the delay relays to perform that function. The control circuit continues through the other set of contacts of S4F to light the indicator lamp E10F (Rectifier filament delay) and then goes to the oscillator-amplifier

control switch D11F.

D11F is a two position switch, "Test" and "Operate". In the test position it is possible to operate the oscillator-amplifier unit, which is the low power section of the transmitter, independently of the power amplifier. With D11F in the "Test" position there is no automatic delay for the protection of the rectifier tubes in the oscillator-amplifier unit. Therefore it is necessary that the filaments of this unit be energized at least 15 seconds before the "Plate Rectifier" switch is turned "On".

OSCILLATOR-AMPLIFIER BIAS AND PLATE CONTROL: With D11F in the "Operate" position the circuit is connected to terminal 30F, to terminal 6A, through the oscillator-amplifier door switches D9.1A D9.4A and D11F again to terminal 32F. (The terminals referred to are indicated on the diagram of Figure 8.) From terminal 32F the control circuit passes through the antenna coupling unit door switch D1E and the power amplifier unit door switches D2C and D5C, the high voltage rectifier unit door switch D3G and the enclosure gate switch, and back to the control unit and terminal 36F. Associated with the high voltage rectifier door switch is a multi-element grounding switch D1G by means of which all the high voltage elements of the rectifier are grounded when the door of this unit is open. This provides protection for personnel against the possibility of high voltage charges being maintained on a filter condenser after primary power has been removed.

From terminal 36F one branch of the control circuit connects through D11F in the "Operate" position to terminal 10A and then to relay S2A which applies power to the plate circuit of the bias rectifier in the oscillator-amplifier unit. The control circuit from terminal 10A also passes through the plate voltage switches D4A and D5F to relay S3A which operates through contacts on S2A. Thus, if S2A has operated, supplying grid bias to the amplifier tubes, the contacts of S2A and S3A are closed, supplying power to the high voltage transformer of the plate voltage rectifier. If, however, for any reason S2A has not operated with the consequent application of grid bias to the amplifier tubes, it is impossible to supply anode voltage to the plate supply rectifier, and hence to the amplifier plates.

To the left of D11F is shown the oscillator-amplifier overload relay S7A which is operated by excess plate current through

R85A. When S7A operates due to excess plate current in the low power unit it is locked up by alternating current from the 20 volt filament transformer through the overload release keys D11A and K5F. Operation of S7A closes contacts which short circuit the winding of S3A, thus removing power from the plate rectifier circuit. To release S7A and hence to resume operation it is necessary to press one of the overload release keys, D11A or K5F. If the overload is temporary and not due to defective apparatus, operation of one of the release keys will open S7A removing the short circuit from the winding of S3A, and operation will continue. On the other hand, if the overload is due to actual breakdown of apparatus, S7A immediately will close again and remove plate voltage from the oscillator-amplifier unit.

It should be noted that in the transmitter under discussion the plate rectifier in the oscillator-amplifier unit is made up of two sections, with 1500 volt output for operation of the smaller tubes, and 3000 volt output for operation of the intermediate amplifiers. In the case of an overload on the 1500 volt output relay S7A will not operate, but a fuse in the ground connection of the rectifier may blow. (See Figure 4, upper left corner.)

POWER AMPLIFIER BIAS CONTROL: The second branch of the control circuit from terminal 36F proceeds to energize relay S4P, the operation of which applies power to the plate circuits of the bias rectifiers, thus supplying grid bias voltages to the power amplifier tubes. Closure of S4P lights indicating lamp E21F which indicates that grid bias has been supplied to the final power amplifier tubes.

POWER AMPLIFIER PLATE VOLTAGE CONTROL: The control circuit for operation of the power amplifier plate supply rectifier proceeds from D2F (upper left) through S1F, D3F, S2P and the upper contacts of S4P to the high voltage rectifier switch D4F. Through these switches and relays the following protection to the power amplifier and high voltage rectifier tubes is obtained: First, by means of S5P the pump and blower motors are started; second, by means of the water-flow relay and S1F the power amplifier filaments cannot be energized, even though the switch D3F is closed, until adequate water-flow is established; third, until S2P operates to turn on the power amplifier filaments the control circuit of the high voltage rectifier is open through the upper auxiliary contacts of S2P; fourth, the circuit passes through the upper contacts of S4P which

20

B-11

relay functions to apply anode voltage to the power amplifier grid bias rectifiers so that bias is established before plate voltage is applied to the final tubes; fifth, S4P is in the chain of control which originates on the closing of D1F (lower left) and a time delay is introduced between a closing of D1F and S4P sufficient to allow the high voltage rectifier filaments and the temperature of these tubes to come up to normal before S4P functions.

From the upper contact of S4P the high voltage control circuit proceeds to D4F, the high voltage rectifier switch. This switch normally is in the closed position. From D4F the control circuit applies power to one side of the motor which operates circuit breaker CB10P. Operation of this breaker applies voltage to one side of each of the three phase windings of the high voltage plate supply transformer.

The control voltage also energizes relay S10F, the contacts of which close the 24 volt d.c. supply circuit to the under-voltage release coil of the circuit breaker (as shown in Figure 8 immediately to the right of motor M of CB10P). After breaker CB10P is closed current through the under-voltage release coil holds the breaker closed.

The closure of CB10P, or its reclosure after an overload or under-voltage has tripped it, is controlled by relays S8F, S9F, and the reclosure relay S12F. The control circuit from terminal 57F applies voltage to one contact of S8F and one side of S12F, and to a back contact in S12F through an auxiliary switch in the circuit breaker which is closed when the circuit breaker is opened. Relay S8F is energized through the back contact of S9F. Relay S8F locks up through one contact and through the other contact energizes S12F and the circuit breaker closing motor. S12F latches up. When circuit breaker CB10P closes, its auxiliary contacts close, connecting terminals 60F and 61F to the return side of the control circuit. Through 61F relay S9F is energized; S9F locks up through the make contact and de-energizes S8F through the break contact. When S8F releases, the motor mechanism on the circuit breaker and the operate coil of S12F are de-energized and S9F is released. Through terminal 60F relays S13F and S14F are energized. S14F extinguishes lamp E27F (circuit breaker open) and completes the circuit to the positive side of the 24 volt relay circuit.

S13F is a delay relay; after two seconds it operates to energize

S1P, the contacts of which short circuit the charging resistance (R_1 in Figure 5) in series with the rectifier filter condenser. The indicator lamp E26F (circuit breaker closed) is energized as is the timing motor in S12F. If the breaker remains in the closed position for a period equal to, or longer than the present adjustment of the timing motor, the release coil in S12F will be energized and restore S12F to normal. If, for any reason, the circuit breaker is tripped by the overload circuit the above closing sequence is again started by the auxiliary contact of the breaker between 58F and 59F. If, however, the breaker is tripped out before the timing motor resets S12F (such as in the case of a short circuit or real breakdown rather than a temporary flashover) the breaker will remain open until the manual push button K2F (circuit breaker reclose) is operated to energize S8F.

POWER AMPLIFIER OVERLOAD TRIPPING CIRCUIT: The plate circuit breaker CB10P is equipped with both instantaneous and inverse time A.C. tripping elements as well as the d.c. under-voltage release coil. In case of large overloads such as those caused by arcbacks in the rectifier tubes the A.C. trip elements open the breaker directly. The under-voltage release coil is supplied from a 24 volt rectifier X1F as previously explained. The armatures of the overload relays S1C, S2C, and S1G are connected in the positive side of the 24 volts supply. The make contacts of these relays are connected across the under-voltage release coil so that the operation of an overload relay short circuits the coil, thus tripping the breaker.

The back contacts on the overload relays connect to holding windings of associated lamp relays. These indications are shown across the upper right half of Figure 8. Normally these lamps are lighted and if extinguished could be lighted by the lamp reset K3E. The lamp reset temporarily provides a circuit to one winding of the indicator lamp relays, permitting them to close. When these relays close they lock themselves up to an auxiliary set of contacts from the upper -24 volt bus through the upper lamp relay winding, through the lower contact of the overload relays and back to the +24 volt bus. When an overload occurs in a power amplifier tube--for example, in the tube associated with relay S2C--the excess current causes that relay to function, a short circuit is placed across the under-voltage release coil of CB10P opening that breaker

and at the same time the holding circuit of lamp relay S30F is opened and lamp E30F is extinguished. This indicates at once to the engineer where the overload has occurred.

Three high power overload relays are provided: S1C and S2C are in the plate return circuits of the two power amplifier tubes, respectively, and S1G is in the return circuit of the high voltage rectifier itself. It should be noted that while the operation of S12F permits the quick reclosure of CB10P in the event of a temporary flashover, the overload indication lamp remains extinguished until reset key K3F is closed. Thus, even though operation continues in the event of temporary overload the indication to the engineer tells him where the overload occurred, and he is able to investigate, and determine whether the temporary overload is an indication of possible breakdown of apparatus.

REDUCED POWER CONTROL: The manner in which "Full Power" or "Reduced Power" is selected by means of the operation of S7.1P and S7.2P has been explained in connection with Figure 7. The actual switching arrangement is shown in the lower right of Figure 8. The "Reduced Power-Full Power" switch is D9F. In the position shown S7.2P is energized through D9F, the back contacts of S2K, the back contacts of S1K to S7.2P. In this position relay S17F is open. In the reduced power position of D9F, S1K closes, removing power from S7.2P and applying power to S7.1P with the result that the number of primary turns in the plate transformer T1P are increased, resulting in a lower transformer turns ratio and reduced rectifier voltage. At the same time S17F is closed which closes the 24 volt d. c. circuit to the winding of a relay not shown, S9A, which reduces the speech input and negative bias on the amplifier tubes to provide operation at reduced power. Also, S2K is energized with the result that the grid bias applied to one of the final power amplifier tubes of the Doherty amplifier is reduced to accommodate the lower plate voltage applied to that stage. The same operation is performed for the grid bias of the second power amplifier tube by the second set of contacts on S1K. Thus, by simply throwing switch D9F from "Full Power" to "Reduced Power" or vice versa, the proper plate voltages, negative grid biases and speech input are obtained for correct operation at the desired output.

POWER INTERRUPTION: By power interruption in this case is meant the temporary loss of primary power to the transmitter through

some failure of the basic power source. Many stations arrange for two separate power sources, and where two outside power sources are not available usually a local power source such as a gasoline driven engine-generator set will be installed. In any case, however, even where automatic transfer from one power source to another is provided, a power failure of the basic supply will result in at least a few seconds suspension of power. It is highly desirable that in the event of temporary suspension of power, the transmitter be returned to the air as quickly as possible after service is resumed.

In the transmitter under discussion re-application of power after temporary suspension is provided by relay S16F shown toward the lower left of Figure 8. When the rectifier filament circuit is energized 230 volts from the control circuit is applied to auto-transformer L1F which in turn supplies 115 volts to terminals 1 and 2 of S16F. Rectox RF1 and condenser C1 then provide a d.c. voltage across voltage divider Rg. Condenser C2 starts charging through R1. When the voltage across C2 reaches the proper value V1 breaks down and starts conducting between the two principal electrodes. (These are the two electrodes on the left of V1.) As soon as a tube starts conducting there will be a conducting path established from the third electrode to one of the main electrodes. Relay S1 in series with this third electrode will operate and close its contacts connected to terminals 3 and 4. The back contact removes an equivalent load from the circuit when the relay is energized. If S16F is de-energized C2 will discharge through R1 and R3, and for a very short time will maintain a current between the electrodes through R2. If voltage is reapplied while the condenser is still at sufficient voltage to be maintaining the current between electrodes through R2, relay S1 will operate immediately. If, however, C2 has discharged to such a value that the tube is no longer conducting between the electrodes when power is reapplied, C2 must be recharged to the value necessary to breakdown the tube. The time required to charge C2 will be a function of the length of time C2 has been discharging. Hence, the delay in the operation of S1 will be proportional to the length of time power is off. If C2 is completely discharged the delay on S1 will be approximately 18 seconds. This delay is necessary because if the mercury vapor rectifier filaments have cooled it is essential that the filament power be applied sufficiently before

application of anode voltage to permit the reheating of the rectifier tubes. If the power interruption occurs after V1 has broken down C2 will maintain the conduction in the tube for about one-half second. If the power is reapplied during this half-second S1 will operate immediately. For any other condition of charge on C2 there will be up to eighteen seconds delay in the closing of S1.

S16F is energized at the same time as S2F. S4F is operated through the contacts of S16F and S2F in series. When S16F and S2F are energized, S16F will close its contacts in about 18 seconds. In about three minutes S2F will operate and energize S4F which locks up. S3F is also operated. In case of power interruption S4F and S2F will release. However, S3F, the contacts of which are in parallel with S2F, will not release for a period of about seven seconds. If power is reapplied during this seven second period S3F will be operated after the delay explained above. As soon as S16F operates, S4F will lock up and the transmitter will be restored to operation. If the power interruption is longer than the seven second period the full delay for the operation of S2F (three minutes) is required before S4F is locked up. Thus, for power interruption up to about seven seconds the delay for reheating the rectifier filaments is proportional to the length of power interruption.

As previously mentioned the three minute delay required by S2F to close can be eliminated by closing the delay release key K1F shown immediately to the right of S16F. Thus, if power has been off more than seven seconds, but not enough to require a three minute period for the rectifiers to warm up, after waiting a few seconds after power has been reapplied to the rectifier filaments, operation can be resumed by closing K1F which closes and locks up S4F.

RADIO FREQUENCY PROTECTIVE CIRCUIT: The operation of the radio frequency protective circuit is accomplished by relays S3C and S10A. The purpose of this relay is to remove excitation from the final power amplifier in the event of a change in the balance between the input and output circuits, that is, any change which affects the phase relation or the voltage relation between the grid and plate circuits of the final power amplifier. The sampling voltage is taken from the grid and plate circuits, the center tap between the two coils connecting to a rectifier. The voltages on the two sides are so adjusted by means of taps on the coils that

when the amplifier tuning is correct one voltage will balance out the other and minimum or zero current flows through the rectifier and hence through relay S3C which is connected in series with the rectifier circuit. After the final power amplifier has been tuned up, and the protective circuit adjusted to this condition, switch D12F normally is closed and relay S3C is opened because in the balanced condition there is no current flowing in this circuit. However, should an unbalance occur in the power amplifier for any reason, the balanced condition of the voltages applied to the rectifier of the protective circuit no longer will exist, current will flow through S3C, and when that current attains a value between 7 and 10 milliamperes, the contacts of S3C will close and in turn will close relay S10A which connects across the 24 volt D.C. circuit.

The operation of S10A closes one pair of contacts which increases the negative bias on the buffer amplifier tube immediately following the crystal oscillator to the point where the output of the oscillator is blocked and RF excitation of the transmitter is removed. The back contacts of S10A are opened at the same time, removing power from lamp relay S51F which extinguishes lamp E51F and indicates the source of trouble. Another pair of contacts on S10A removes the speech input voltage from the transmitter.

Thus, while the RF protective circuit in the event of unbalance in the final power amplifier does not remove high voltage from the amplifier tubes, it does remove excitation from the grids of all RF amplifiers and hence cuts off the carrier. This operation could occur if tuning of the final power amplifier were inadvertently changed.

STARTING PROCEDURE: A recapitulation of the operation of the control circuit can be given briefly in describing the actual starting procedure for the transmitter under discussion. It is true that if all manually operated switches were closed the current sequence of starting could occur with the closing of the main line switch to the transmitter. However, much better tube life will be obtained in transmitters of medium and high power if, after having been shut down for a number of hours, the starting procedure is made more gradual and the tubes, especially the mercury vapor rectifier tubes, are allowed to warm up for a few minutes before the application of anode or plate potential.

To start the transmitter all the manual circuit breakers in

the power distribution unit (see Figure 7) should be thrown to the "On" position and switch D11F should be in the "Operate" position. Check the voltage of the three phases of the power supply by means of the "Power Supply" meter M1F and the meter switch (not shown). Each phase should measure approximately 230 volts.

Throw switch D53F and switch D54F to "On". These switches apply power to the control circuit and to the 24 volt Rectox unit. All meter lamps should light. Green lamps above the three branch systems of the control circuit should light: switch D10F, lamp E54F; switch D2F, lamp E3F; switch D1F, lamp E1F.

In order to allow proper preheating of the rectifier tubes the filaments should be energized before the rest of the equipment. Close switch D1F. The red lamp E2F above this switch should light. Delay relays S2F and S16F are energized. After about twenty seconds relay S16F operates and after three minutes relay S2F operates followed immediately by relays S3F and S4F, lighting the "Rectifier Filament Delay" lamp E10F. With switch D11F in the "Operate" position, all doors closed, and the high voltage grounding switch D1G open, all the door lamps will light and the bias contactor S4P will operate, energizing the bias rectifier and lighting lamp E21F. The bias voltmeters M2F and M3F should indicate the proper bias voltages.

The oscillator-amplifier filaments may be energized at any time, but preferably should be started a few minutes before the rectifier filaments have been completely preheated. Close switch D10F. This will operate contactor S3P. All switches in the oscillator-amplifier unit itself should be left in the "On" position.

The safety disconnect switches D1W and D2W (Figure 7) should be kept closed except when servicing the associated pump or radiator blower motors. Set the valves to the water system as instructed in the directions. The cooling system is then placed in operation by closing switch D2F. Relay S5P operates, starting the pump and radiator blower motors.

When proper water flow is obtained the flow relay WD1W and relay S1F operate. Lamp E8F lights, and the green lamp E6F above switch D3F lights, indicating that the filaments may be energized.

Close switch D3F, thus energizing relay S2P and supplying power to the power amplifier filaments.

At the same time that the bias rectifiers are energized the

control circuit is complete to the high voltage control of the oscillator-amplifier unit. With switch D4A in the "On" position the green lamp E19F above switch D5F lights. Throw this switch to "On", operating S3A and energizing the plate rectifier of the oscillator-amplifier unit.

As soon as all amplifier filaments and bias rectifiers have been energized, the control circuit of the high voltage rectifier for the power amplifier is completed and the green lamp E23F above switch D4F lights.

Close D4F energizing the closing circuit for the plate circuit breaker. Lamp E27F lights. As soon as the breaker is closed this lamp is extinguished and the lamp "Closed" E26F lights. The rectifier is energized and meter M7F (power amplifier plate) should read about 12 kilovolts. The lamp reset K3F should be pushed to light the overload lamps. If any of these lamps becomes extinguished it indicates the operation of the protective or overload relay in the circuit designated below the lamp in question and after noting the circuit the lamp reset key should again be operated to restore the indication circuit to normal.

The transmitter now should be operating with the desired carrier output, either at full power or reduced power as determined by the setting of switch D9F. The only remaining step is to apply program modulation to the speech input circuit.

The actual control systems, types, location of the relays, etc., and the individual starting procedures will, of course, differ to some extent with different types of transmitters. In the case of low power transmitters the whole procedure will be simplified because there is not so much apparatus which needs to be started and protected. In the case of higher power transmitters the circuits and the procedure will be slightly more complex because of the addition of a higher power amplifier in place of the power amplifier as assumed in the above discussion. However, except for details, the above procedure and arrangement of control equipment is quite similar to that of any well designed transmitter of equivalent power output. If the engineer thoroughly understands one of these systems he should have very little difficulty in becoming acquainted with any radio transmitter control system or power distribution system he may encounter in practice.

CONTROL APPARATUS: Five general types of control apparatus

are used in the circuits of Figures 7 and 8 -- circuit breakers which provide overload protection for the major branches of the power distribution circuit; manually operated switches which may be left closed if complete automatic starting is desired, but which permit any desired section of the circuit to be opened or isolated from the rest of the circuit; power relays or contactors which are simply electrically operated switches so arranged that they automatically apply power to some part of the circuit when energized by the closing of another contactor or switch earlier in the sequence of power application; sensitive light-duty or high speed relays which control the functions of power relays, indicating lamps, provide overload protection for vacuum tubes, etc.; time delay relays which provide a desired delay action in the starting or stopping sequence of the transmitter.

MANUALLY OPERATED SWITCHES: Two types of manually operated switches are shown diagrammatically in Figure 9. Figure 9 (a) illustrates a two pole single throw switch and a single pole single throw switch. Such switches are used as a means of manually isolating a section of a circuit from the rest of the circuit or from the power source.

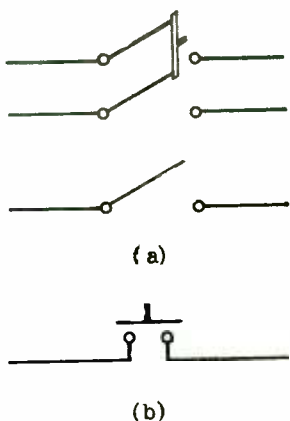

Figure 9 (b) illustrates a momentary contact type of switch. Such switches are used for indicator lamp resets, for bridging around time delay circuits to operate contactors which subsequently lock themselves up, etc. Such switches ordinarily are required to handle very little current (as in low voltage relay circuits) and hence are usually of the push-button type.

Fig. 9. Manually Operated Switches.

Where the disconnect switch of Figure 9 (a) carries only control circuit current at low voltage it may be of the small "key" type. Where it is used as a disconnect device in the power circuit, it may be either a simple blade type switch or a circuit breaker type. In either case it must have a current carrying capacity at least 115 percent of the full-load rating of the apparatus it is required to disconnect.

CIRCUIT BREAKERS: A circuit breaker is a disconnect device

whose normal function is to open the circuit and remove power from equipment in the event of (usually) an overload. Because its principal function is to open the circuit and remove power under conditions of overload--which may be an actual short-circuit--the design requirements are quite severe. When the circuit breaker is designed to open the contacts on overload, the winding of the solenoid tripping device may be connected in series with the circuit to be protected or the connection to the circuit may be made through a current-transformer.

Two main types of circuit breakers are in use in the United States, the air-break circuit breaker generally referred to as an "air-breaker", and the oil-break circuit breaker referred to as an "oil-breaker". The first refers to a breaker in which the contacts open in air; in the second type the contacts open in oil.

Oil breakers find their principal application in large power distribution circuits where the loads are beyond those encountered in any but high power radio installations. In the oil-breaker the contacts are immersed in a tank of special insulating oil. Oil is used because for long-arc extinction, particularly in high voltage circuits, it is more effective as a means of deionization than is air. When the contacts open an arc forms which decomposes the oil in the vicinity of the contacts and forms hydro-carbon gases which do not ionize and help to absorb the arc ionization. A number of devices are used in oil breaker design to ensure adequate production of un-ionized gas from fresh un-ionized oil and to force this gas quickly into the arc.

The principal problem in the design of a circuit breaker is to ensure rapid rupture of the arc that occurs when the contacts open under condition of excess current which, in a large radio transmitter, may be manyhundred or even several thousand amperes. For example, consider circuit breaker CB10P in Figure 7 and 8 through which power is applied to the plate transformer of the high voltage rectifier. If this were a 50 K.W. installation and the final stage operated at 50 percent efficiency, the input power would be in excess of 100,000 watts, allowing for certain rectifier losses. Assuming a 460 volt power source, the normal current through the breaker would be in excess of 200 amperes. If a short circuit developed the instantaneous current could reach several times that value and would have to be broken by the circuit breaker.

The majority of air breakers protect their main contacts from arc burning by the use of auxiliary carbon contacts which take the final arc. Such breakers are commonly called "carbon breakers." Supplementing the pair of copper contacts which carry the current when the breaker is closed is a pair of carbon contacts connected in parallel. When the breaker opens, the carbon contacts remain closed until the copper contacts are well separated, the carbon contacts thus taking the final arc. Under the action of an arc copper contacts will either pit or form globules which adhere to the surface. On the other hand, carbon burns clean and hence makes much better final contacts. Also the comparatively high resistance of carbon is advantageous.

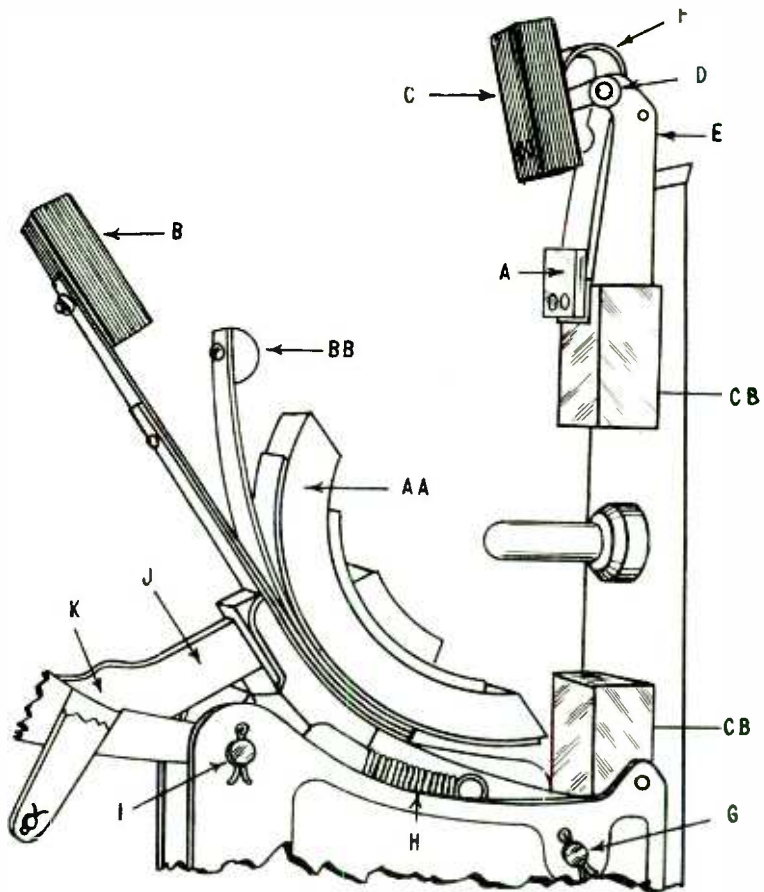

Construction of a Typical Carbon Type Air-Breaker
 Fig. 10

Figure 10 illustrates the construction of a typical carbon type air breaker. The principal parts are as follows: AA, main
 B-11

brush; CB, stationary contact blocks; BB, arcing tip; A, copper arcing plate; B, moving carbon; C, stationary carbon; D, pin; E, carbon holder; F, copper shunt; G, pivot rod; H, springs; I, phosphor-bronze pin; J, phosphor-bronze clip; K, projection on toggle mechanism for large breakers.

The main brush (AA) is made by giving the extra-hard copper-strip laminations a set to a smaller radius than they have in the finished brush. This causes the innermost laminations of the brush to press by spring action against the inside block, and each of the other laminations presses in a similar manner against the laminations in front of it. Each lamination makes an independent contact at each end on one of the stationary contact blocks against which the main brush bears with heavy contact pressure. During the opening and closing of the breaker the laminations of the main brush have a sliding motion relative to the stationary contact blocks, this motion breaking up any oxide film which may have accumulated.

As the breaker opens AA-CB opens first, then A-BB and finally the carbon plates B-C which take the final arc. In the usual air breaker the arc is extinguished simply by the increased distance between B and C. When closed, the contacts are latched up against the pull of a strong spring, H. When the breaker is unlatched by means of the overload opening device, the spring causes the contacts to separate very rapidly thus quickly extinguishing the arc.

An alternating current arc is much easier to break than one in a D.C. circuit. When a circuit carrying appreciable current is broken and an arc starts, the air between the contacts becomes ionized and the resistance of the ionized air drops to a sufficiently low value to maintain current flow even with comparatively low voltage. In the case of a D.C. arc, THE APPLIED VOLTAGE IS MAINTAINED while the air gap widens and the rapid ionization of the air prevents the arc from being extinguished until the gap is quite long.

The condition is considerably different in the case of an A.C. arc. In such a circuit the voltage passes through zero twice each cycle--120 times per second in a 60 cycle circuit. As the voltage passes through zero, for an instant there is no E.M.F. present to maintain the arc. Under this condition deionization begins

rapidly, the major recovery of air dielectric strength taking place in the layer next to the cathode. A dielectric strength of 250 volts is recovered in a thin air layer immediately and subsequent deionization is very rapid. Thus the short A.C. arc is broken as the voltage cycle passes through zero and under any normal condition is extinguished in less than the time of one-half cycle, even without the necessity for a very long air gap. The principal requirement for short arc interruption is adequate contact between the air and the cathode surfaces so that deionization is rapid. This is provided as shown in Figures 10 and 11 by the use of large carbon surfaces.

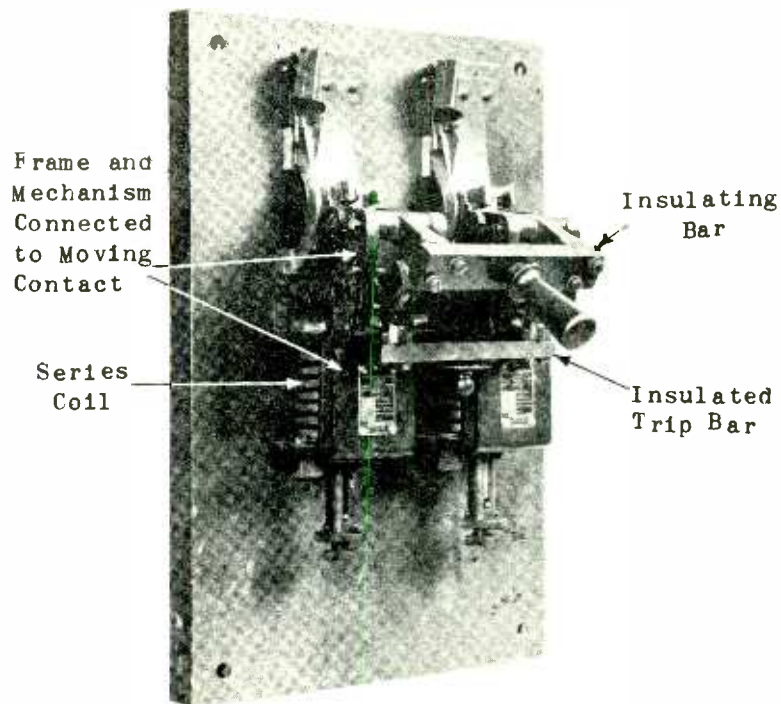

Fig. 11. Two-pole Air Circuit Breaker (carbon breaker)
(Courtesy of Westinghouse Elec. & Mfg. Co.)

On larger breakers, particularly those operating in high voltage circuits, other devices are added to assist in breaking the arc. One such device is a magnetic blowout. This impresses a strong magnetic field across the gap between the contacts forcing the arc

outward and increasing its length between the carbon surfaces so that it ruptures more quickly. Another device is the "de-ion" breaker in which the long arc is broken up into a number of short arcs in series and means are provided for quickly extinguishing the short arcs.

Figure 11 illustrates a typical two-pole air circuit breaker. The breaker has been closed by downward pressure on the handle and is latched up. The lower breaker mechanism consists of two solenoids actuated by series coils through which the load current flows. When the load current exceeds the desired maximum value, the solenoids operate to release the latching mechanism and springs cause the contacts to fly open. The manner in which the upper (carbon) contacts remain closed for an instant after the main brush contacts open is clearly seen from the illustration. The solenoid adjustments for desired tripping action are shown beneath the respective solenoids.

Where rapid automatic reclosure is required after overload--as in the case of CB10P in Figures 7 and 8--a motor driven closing mechanism is required. In such a breaker the motor disengages after the breaker contacts are closed and locked up, the motor again being connected to the closing mechanism when the breaker opens due to overload or under-voltage release. In the case of CB10P the breaker is held closed by the under-voltage release solenoid which is energized by 24 volt d.c. power from a Rectox rectifier. That arrangement permits the breaker to open due to failure of the main power supply which of course de-energized the holding coil.

Another type of circuit breaker used extensively for pump and blower motor protection is the "thermal cutout". Such a device consists of a set of contacts which latch up when closed. A bimetallic thermal element is so arranged that the load current passes through it. When the load current becomes excessive the bimetallic element expands or twists in such a manner as to release the latching mechanism permitting the circuit contacts to fly open. This device should not be used where instantaneous opening on large overload is required (as in high power vacuum tube or rectifier circuits) because an appreciable time is required during overload for the thermal element to cause sufficient movement to unlatch the contacts. For some types of loads this delay is advantageous as a temporary

overload lasting only a few seconds and not long enough to damage the apparatus or wiring does not disconnect power from the load circuit. On the other hand, the setting should be such that if the overload is not temporary, power is removed before damage to apparatus results.

CONTACTORS, POWER RELAYS: These are electrically operated switches. Several types are shown in Figures 12 to 15 inclusive, (courtesy Ward Leonard Electric Co.). The principal of all is the same. One or more fixed contacts are mounted on an insulated base. Opposing movable contacts are mounted on an insulating arm which is attached to a pivoted laminated iron armature. An electromagnet is so mounted that when the coil is energized the armature is drawn upward sharply closing the contacts. When the relay is designed for D.C. operation the armature and magnet core may be solid iron. For A.C. operation, to minimize losses both must be laminated and the laminations tightly clamped or riveted to prevent vibration.

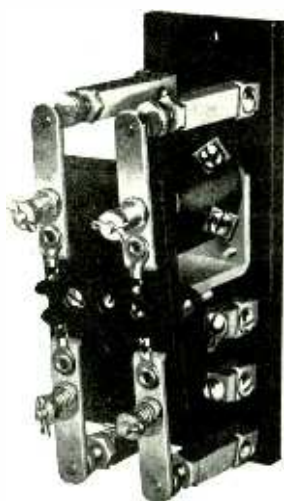

Heavy duty relay with two poles normally open and two poles normally closed.

Fig. 12.

The contacts will carry, in the range of 125 - 250 volts, 25 amperes A.C., 1 ampere d.c., and 10 amperes d.c. if provided with magnetic blowouts. (It should be noted that both contactors and circuit breakers have a lower d.c. than A.C. current rating because it is much more difficult to extinguish a d.c. arc than an A.C. arc when the contacts open. The reason for this is that the voltages

in the A.C. circuit periodically passes through zero so that during that portion of the cycle there is no voltage to maintain the arc. This is not true in the d.c. circuit; the d.c. arc must be extinguished by length of air gap or by some other means. In the case of the contactors illustrated, the air gap is not long and their breaking ability for direct current is distinctly limited. This is not a serious problem in modern radio transmitters because A.C. power is almost universally used.

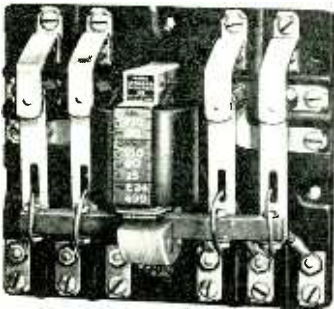

Fig. 13.

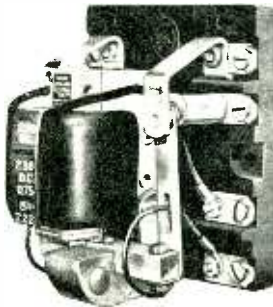

Fig. 14.

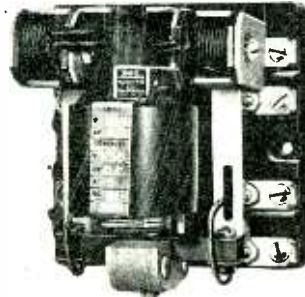
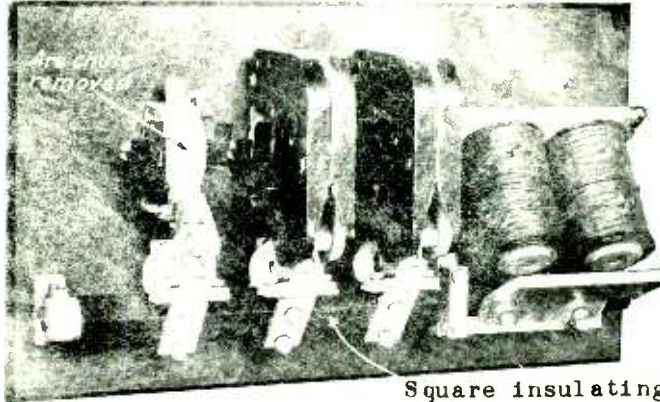

Fig. 15.

Figure 13 illustrates an intermediate-duty four pole relay, each pole of which has both back and front contacts. Such a relay could be used, for example, to connect a three wire circuit to a power source with the fourth set of contacts used to connect a holding circuit. S7A in Figure 8 illustrates one use of a four contact relay. Of course either the back or front contacts, or both may be used.

Figure 14 illustrates a two pole relay having both front and back contacts. Such a relay may be used to close a two wire circuit, open a two wire circuit, or open one circuit while simultaneously closing a second circuit, etc.

The relay of Figure 15 is similar to that of Figure 14 except that it is provided with blowout coils and hence is more suitable for connecting a d.c. circuit than is the relay of Figure 14. The blowout coils are shown at the top, mounted immediately over the contacts. When the contacts open each blowout coil develops a strong magnetic field which forces the arc outward from between the contacts thus increasing the arc distance between contacts.



Square insulating tube
over operating bar

An Alternating Current Contactor, with
operating coils at one side of contact.
(Courtesy of General Electric Company).

Fig. 16.

Figure 16 illustrates an alternating-current contactor which connects a three wire circuit. The operating coils are shown to the right. The arc chute has been removed from the contactor on the left to show the mechanism. Arc chutes are used to confine the arc and are made of cold-molded insulating composition which must be so compounded that good heat resistance is obtained and copper deposits from arcs will not collect on the surface. Arc chutes are generally hinged so that they can be swung up or down to allow examination and replacement of contact surfaces.

An example of the use of a heavy duty contactor of this type would be for filament power for high power transmitting tubes, the coils being energized from the control circuit.

SENSITIVE RELAYS: The sensitive, light-duty or high speed relay operates on exactly the same principle as the contactors described above, the only differences being in the current required to operate it and the current carrying capacity of its contacts. Figure 17, (courtesy Ward Leonard Electric Co.), illustrates a typical sensitive relay. This relay is designed for operation on approximately 14 milliwatts. The contacts will break .75 ampere at 115 volts d.c., .5 ampere at 230 volts d.c., and 1.5 amperes at 110 - 220 volts A.C. Hence such a relay could be used to control the contactors of Figures 12 to 15 inclusive.

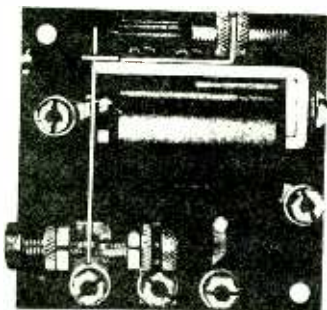

Fig. 17. Sensitive or Light Duty Relay.

Such relays also are used to control indicator lamps; in low power vacuum tubes they serve as overload relays and in higher power tube installations a similar relay can be used in conjunction with a shunting resistor for the same purpose.

The relay of Figure 17 can be obtained with a wide range of coil ratings. At one extreme, the coil has resistance of .52 ohm, requires 162 milliamperes for relay operation, and has voltage drop across the coil of .08 volt. Such a relay would make an excellent overload relay for vacuum tubes normally operating with plate current in the range of 75 - 125 milliamperes. On overload the relay would operate when the current reached approximately 150 milliamperes. (It should be noted that the operating point is adjustable over reasonable limits.)

On the other extreme is a coil having resistance of 31,000 ohms, requiring operating current of only .65 milliampere, and having a voltage drop of 20 volts. Such a relay could be used in conjunction with a photoelectric cell for controlling lighting circuits. In a control circuit as in Figure 8, a number of such relays could be connected across the 24 volt D.C. circuit for indicator lamp controls with negligible current drain on the rectox unit. A number of coil resistance and current ratings are available between the two described.

The relay of Figure 17 has three adjustments: an adjustment for spacing of each stationary contact (front and back) with respect to the armature. This adjusts the length of the gap for circuit break. The third adjustment is for spring tension which provides some control over the minimum current at which the relay will operate. The greater the spring tension, the greater the coil current required for relay operation.

It is very important in the selection of sensitive relays for a control circuit that the control circuit voltage and relay coil resistance be properly matched. For example, if the 31,000 ohm relay described above which is designed for 20 volt drop is placed

across a 12 volt circuit, it cannot be adjusted to operate satisfactorily. On the other hand, if a 11,300 ohm 12 volt relay is connected across a 20 volt circuit the coil current will be excessive and the coil will overheat.

While Figure 17 illustrates only a single pole double throw relay, multipole sensitive relays can be obtained to perform any number of control functions.

The adjustments should be such that the contacts close firmly in each direction. In adjusting the front or "relay closed" contact, it is essential that this contact be not "backed off" too far because in that event the armature may strike the pole face and not make firm contact. On the other hand, if the contact is moved too far forward, the gap between the armature and pole face will be excessive and the holding force of the magnet may be decreased to the point where relay closing becomes erratic and unstable. An optimum adjustment will be found between those extremes at which there is the minimum perceptible spacing between armature and pole face.

The relay contacts, both armature and stationary, should be cleaned at regular intervals. Corrosion or burning will form a high resistance contact which may seriously affect the operation of the control circuit. Cleaning and polishing of contacts should be done in such a manner as not to scar or wear them unnecessarily. This applies particularly to small contacts of low power and program relays. If because of VERY BAD condition of burning an abrasive is necessary, nothing coarser than VERY FINE sandpaper should be used--and that gently. Contacts that are scarred or unevenly worn tend to bear against each other only at peaks with the effect that the surface areas in actual contact are substantially reduced. This results in greater contact resistance, increased tendency to burn, etc. In power contactors designed to break large currents, the contacts usually are arranged to close with a sliding or rolling motion against each other, this tending to break up any oxidation film and keep the contacts clean.

TIME DELAY RELAYS: Time delay relays are used wherever it is necessary to delay the closing of one circuit after another circuit closes or to delay the opening of a circuit after some controlling circuit has opened.

Several examples of necessary delay action are illustrated

in Figure 8. It is necessary to delay the application of anode voltage to the mercury vapor rectifiers until after the filaments have been energized and the tubes have warmed up. The power amplifier tube filaments must be allowed to reach proper operating temperature before plate voltage is applied. It is desirable that the contacts of S16F remain closed for a fraction of a second to prevent the necessity for delay action in starting in the case of fractional-second power interruptions. In motor and generator circuits it is desirable that power be not removed instantly during overloads that are of very brief duration and time delay cut-outs are used for such purpose.

Several types of time delay relays are in common use. Figure 18 illustrates a motor driven type. This



Motor Driven Time Delay Relay.

Fig. 18.

consists of a small synchronous motor, a gear train, a pivoted tripping arm, and a magnet operated clutch between the trip arm and the gear train. At the instant of tripping the contacts, a limit switch opens, disconnecting the motor. The motor drives the relay contacts through a step-down gear ratio. By proper selection of gear ratio it is possible to provide any desired time delay between the application of energizing voltage and the closing of the contacts.

The instrument of Figure 18 (Ward Leonard Electric Co.) can be obtained with any one of three standard gearings: 5 seconds to 54 seconds; 30 seconds to 4.5 minutes; 2.5 minutes to 22.5 minutes. It is noted that in each case the range of time delay adjustment is approximately 10:1. Where a synchronous motor is used, the selection of time delay within the specified range is made by varying the distance the controlling mechanism must travel before the contacts close. Where another type of motor is used, the time of delay may be regulated in a similar manner or by means of a braking device.

A second type of time delay relay employs a mechanism similar to the escapement of a clock. When the relay solenoid is energized the contacts tend to close, thus exerting a torque on the gears

of the timing mechanism and causing them to rotate; but the escape-ment limits the rate of rotation, thus fixing the total time required for the contacts to close.

A third type of time delay relay employs a "dash-pot" in which a plunger moving in a cylinder filled with heavy oil limits the rate at which the contacts close. The plunger fits within the cylinder in such a manner that oil escapes from one end of the cylinder to the other past the plunger or through holes in the plunger as the latter moves under the magnetic pull of the solenoid. The total time delay in contacts closing can be regulated by the distance the plunger travels or by the rate at which oil is allowed to pass the plunger as it moves upward.

Another type of dash-pot construction employs a dry cylinder in which suction between a close-fitting piston and cylinder is used to effect the desired time delay.

A fourth type of time delay relay in common use employs a bimetallic thermal unit. When the relay is energized a circuit is closed through the thermal unit heating the bimetallic element and causing it to change in shape with consequent movement of one end on which is mounted, through suitable insulation, the contacts to be closed. In this case the time delay can be adjusted by regulating the current through the thermal element or by regulating the distance the contact-bearing end of the element must travel.

The thermal time delay relay principle can be used in the reverse function to open a circuit under overload by causing the motion of the bimetallic element to trip contacts which open sharply under spring tension. In this case the normal load current will not cause sufficient thermal element motion to trip the holding mechanism and delay is effected under overload by the time required for the increased current to become effective in terms of temperature rise and mechanical movement.

Motor starters of the "across the line" type are provided with thermal trip devices. In locations where abnormal ambient temperatures are encountered, or where vibration is severe, it may be advisable to install thermal elements of the next larger size in order that the breaker does not tend to open the circuit during periods of normal load. Make sure that the cause of the breaker tripping is NOT overload before installing elements of greater capacity.

A fifth type of delay relay is illustrated in Figure 19. This is a delayed drop-out relay similar in principle to that of S16F in Figure 8. The contactor element itself is conventional but

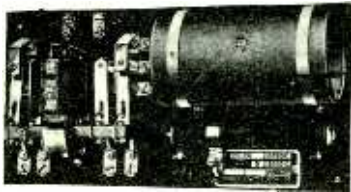

Delayed Drop-out Relay.

Fig. 19.

the winding is energized by a d.c. voltage which also charges the large condenser shown to the right of the contactor. If power is removed from the relay for any reason the charge in the condenser will provide current through a resistor (immediately below the condenser) to hold up the contacts for a fraction of a second after main power is removed. The actual time delay in opening is regulated by the adjustment of the resistance, the lower the resistance the more rapidly the condenser discharges. If main power is reapplied before the contacts open, the circuit is again energized and the relay contacts, and consequently the circuit through them, do not open. The delayed drop-out relay ordinarily is used in conjunction with a "time delay to make" relay to jump around the latter for very brief power failures.

SERVICING SWITCHES, BREAKERS AND CONTACTORS: Relay servicing is comparatively simple but must be carefully performed. The delicate contact fingers in high speed relays should be checked carefully after each cleaning operation, making sure that good wiping occurs on contact "make" and that the back contacts do not follow the bar too far as it moves to the opposite position. Plunger type relays must be perfectly free in their tubes and should trip their contacts with a definite "snap" as the toggle is tripped.

Contacts of high speed relays should be cleaned with a clean piece of cloth moistened with carbon tetrachloride, then wiped off with a dry piece of bond paper. In extreme cases, the contact surface may be burnished with crocus cloth. Always wipe the contacts with dry paper after any cleaning operation, and operate the relay manually several times to assure correct alignment.

Large contactors of the air-brake type may require dressing with a mill-type file when contacts are severely pitted. Adjustments are provided for maintaining correct contact alignment and "wipe". Keep the pole faces clean and see that they seat securely. Check the operation manually, tightening any loose screws. Replace

broken arc-chutes and magnetic blowouts. "Overlapped" fingers should be checked frequently to see that their sequence is correct with respect to other contacts. If contacts are cleaned and adjusted regularly much less trouble and expense will be encountered than if they are left alone until trouble develops.

Contacts in oil-breakers should be checked manually to make sure they operate freely and seat properly. When the tank is dropped for examination of the oil, check all contact fingers and renew any members that are badly burned. Examine the bushings for cracks and oil leaks. Oil circuit breakers having V-type fingers should be checked for alignment whenever the tank is removed for oil inspection.

It is important that the insulating oil in oil-breakers be maintained at the proper level; this level should be checked at regular intervals and the oil renewed every two or three years, particularly in humid climates.

Dirt and gummed oil must not be permitted to accumulate in bearings and between the moving parts of circuit breakers and contactors. Such an accumulation will result in sluggish operation or even render the device inoperative.

Spring tensions on breakers should be checked periodically with spring scales and maintained in accordance with manufacturer's specifications. If spring tension is allowed to decrease all adjustments will be changed.

Oil dash-pots in delay relays must be kept properly filled with the special oil specified and their operation tested at regular intervals. Only the factory-specified oil should be used to ensure proper viscosity. Oil dash-pots tend to operate sluggishly in low temperatures. Dry type dash-pots which operate on the suction principle sometimes stick due to accumulation of dust in the cylinder.

Bushings on potential transformers must be kept clean.

CAUTION: NEVER LEAVE THE SECONDARY CIRCUIT OF A CURRENT TRANSFORMER OPEN. If it becomes necessary to remove an over-current relay actuated by a current transformer, short-circuit the current-transformer secondary winding until the unit has been replaced and permanently connected in the circuit. The induced voltage in an open current-transformer secondary may endanger personnel and almost certainly will break down the insulation on the low voltage second-

ary winding.

INDUSTRY ACKNOWLEDGEMENT: We wish to express appreciation to R.C.A. Manufacturing Company, Ward Leonard Electric Company, and Western Electric Company for circuit and technical data used in the preparation of this lesson.

POWER AND CONTROL CIRCUITS FOR BROADCAST TRANSMITTERS

EXAMINATION

1. (a) Describe power supply of W.E. 50 KW. Broadcast Transmitter Type 407-A.
(b) What special relation should exist between filament voltage and anode current in a large mercury vapor rectifier tube?
(c) Describe the arc-back relay circuit.
2. (a) Describe the grid bias supplies to the above equipment.
(b) Describe the power supply for the oscillator-amplifier unit.
3. (a) In the Type 405-A-1 W.E. transmitter, how is operation at lower outputs than 5 K.W. obtained?
(b) What is the function of Relay 1 (Fig. 5)?
(c) What is the function of R_2 (Fig. 5)?
4. (a) What is the function of the Voltage Regulator in the power distribution system for a broadcast transmitter?
(b) Why is a special motor-driven circuit-breaker, CB10P in Fig. 7, employed for the plate transformers?
(c) How is "high power" obtained in this equipment (W.E. Type 405-A-1)?
5. Refer to Fig. 8:
(a) What precautions are taken to prevent the filaments of the power amplifier tubes from being turned on before the cooling water is circulated?
(b) What precautions are taken to prevent anode potential from being supplied to the rectifiers before power is applied to the filaments?
(c) Why is a grounding switch D1G mechanically associated with the door switch D3G?
(d) Why is relay S3A operated through contacts on S2A?
6. Refer to Fig. 8:
(a) Suppose there is excess plate current in the low power

POWER AND CONTROL CIRCUITS FOR BROADCAST TRANSMITTERS

EXAMINATION. Page 2

6. (a) unit. What relays are operated to remove plate voltage, and how is this supply voltage restored? Which plate voltage is disconnected?
 - (b) Before plate voltage can be applied to the power amplifier what five conditions are taken care of in the control circuits?
 - (c) In the case of a temporary flashover that opens circuit breaker CB10P *momentarily*, why does the overload indication lamp remain extinguished until reset key K3F is closed?
 - (d) Why is S17F relay energized in the "Reduced Power" position?
7. (a) Describe the action of the time delay relay S16F controlling the re-application of power to the transmitter.
 - (b) Describe the function of relay S3F.
 - (c) Describe the function of key K1F.
8. How is any inadvertent change in the tuning of the final power amplifier taken care of, and why is this precaution necessary?
9. (a) How is pitting and burning of the copper contacts in an air circuit breaker obviated?
 - (b) Which type of current, a.c. or d.c., is easier to interrupt? Explain briefly.
10. Describe briefly the various methods of obtaining time delay in a relay.

