



SECTION 3

**SPECIALIZED BROADCAST
RADIO ENGINEERING**

HIGH POWER BROADCAST TRANSMITTERS

Copyright 1951 by
Capitol Radio Engineering Institute
Washington, D.C.

310 E

- TABLE OF CONTENTS -

HIGH POWER BROADCAST TRANSMITTERS

	Page
SCOPE OF ASSIGNMENT	1
HIGH POWER FEATURES OF BROADCAST TRANSMITTERS	1
<i>METHODS OF DEVELOPING HIGH POWER MODULATED R-F</i>	1
<i>DOHERTY HIGH EFFICIENCY AMPLIFIER</i>	1
<i>PRACTICAL CIRCUITS</i>	9
CIRCUIT ADJUSTMENTS	11
<i>FILTER ADJUSTMENT</i>	11
<i>LOAD IMPEDANCE ADJUSTMENT</i>	12
<i>GRID CIRCUIT TUNING</i>	12
<i>FINAL AMPLIFIER TUNING</i>	13
<i>ADJUSTMENTS FOR MODULATED OUTPUT</i>	13
FEEDBACK	15
<i>FEEDBACK ADJUSTMENT</i>	15
THE RCA CLASS B-C POWER AMPLIFIER	18
<i>CIRCUIT ANALYSIS</i>	18
<i>TUNING PROCEDURE</i>	22
<i>TRANSMISSION LINE TERMINATION</i>	23
<i>HARMONIC FILTER</i>	23
<i>GRID TANK CIRCUIT ADJUSTMENTS</i>	23
<i>FEEDBACK CIRCUIT</i>	27
<i>GENERAL CLEANING IN R-F POWER AMPLIFIERS</i>	29
RESUME '	29
<i>INDUSTRY ACKNOWLEDGEMENT,</i>	30

HIGH POWER BROADCAST TRANSMITTERS

SCOPE OF ASSIGNMENT

It is proposed in this discussion to take up the specific high power features of broadcast transmitters (50 kw and up) and the problems peculiar to such transmitters, with little space devoted to the low power end which is essentially similar to complete low power transmitters previously discussed. In particular, considerable space will be given to the high efficiency linear r-f power amplifier developed by Doherty of Bell Telephone Laboratories and its use in the Western Electric 50 kw broadcast transmitter, and to the similar Type B-C high efficiency power amplifier of RCA.

HIGH POWER FEATURES OF BROADCAST TRANSMITTERS

METHODS OF DEVELOPING HIGH POWER MODULATED R-F.— There are two general methods of developing modulated radio frequency at high power for transfer to an antenna: First, by modulating in a low power stage and then amplifying by successive linear radio frequency amplifiers; second, by developing the necessary unmodulated radio frequency power by successive stages of Class C amplification and then modulating the final r-f stage by a sufficiently large Class B audio amplifier.

Both methods have advantages and disadvantages. The advantage of low level modulation is the small amount of audio power required. The

certain amount of distortion introduced by the Class B linear amplifiers can be neutralized without difficulty by the use of inverse feedback. Until the development of the high efficiency linear amplifier by Doherty, (The student is referred to the original paper by Doherty in the September 1936 issue of the Proceedings of the Institute of Radio Engineers.), low level modulation had the serious disadvantage of quite low efficiency — approximately 33 per cent. The low operating efficiency of the power amplifier in a high power transmitter resulted in a larger tube requirement, excessive power cost, a larger rectifier, and in increased water cooling requirement. These factors add to the fixed operating cost as well as to the initial cost of the transmitter installation.

High level modulation has the advantage of high efficiency operation. In such a system the final r-f amplifier is operated Class C and the audio modulator Class B. At least 60 per cent efficiency may be assumed for the Class C amplifier. The serious disadvantage of such an arrangement is the large modulating power required and the cost of such a modulator circuit in a high power transmitter. These factors, while not serious in transmitters up to about 1 kw, become increasingly so as the power is raised, although high level modulation has been used successfully up to 500 kw.

DOHERTY HIGH EFFICIENCY AMPLIFIER.— The Doherty high efficiency linear amplifier offers marked improvement over both of the systems described above. While permitting

the use of low level modulation and the attendant small audio power it, at the same time, allows final r-f amplifier efficiency of greater than 60 per cent, comparable with that of the usual Class C amplifier. It also permits the use of inverse feed-back so that the power amplifier tubes may be operated near their maximum power rating and the consequent distortion cancelled out by feedback.

The ordinary linear amplifier operating at 33 per cent efficiency at 50 kw output requires input power of 150 kw, of which 100 kw is dissipated at the tube anodes. The high efficiency amplifier operating at 60 per cent efficiency with the same power output requires input power of 83 kw of which only 33 kw is dissipated at the tube anodes. This allows a power saving of 67 kw and a reduction of that amount in the anode dissipation so that the tube complement and cooling equipment may be considerably reduced. The tube requirement of an amplifier is determined to a large extent by the anode power dissipation which in the high efficiency amplifier has been reduced by approximately two-thirds.

It is suggested that the student carefully review an earlier assignment on the design of power amplifier and tank circuits before going ahead at this point, as that assignment explains in detail the operation of the conventional power amplifier.

It will be seen that although the theoretical maximum operating efficiency of a linear amplifier is 78.5 per cent, actually the efficiency with unmodulated carrier is from 31.5 to 33 per cent. This is due to the fact that, working into a

fixed load impedance and with the necessity for doubling the unmodulated carrier voltage during the peaks of 100 per cent modulation, and with a further restriction as to the minimum point to which the plate voltage can be driven without excessive distortion, the peak unmodulated plate voltage variations are not sufficiently great for high operating efficiency. Thus to obtain higher operating efficiency it is necessary to vary the plate voltage over greater limits during the unmodulated carrier condition. This is particularly true since, although the efficiency of such an amplifier is greater during modulation peaks, such peaks in ordinary program material occur during only a small portion of the time and the AVERAGE efficiency in broadcasting does not greatly exceed that with unmodulated carrier.

With the conventional linear r-f amplifier there is a very definite limit within which the unmodulated plate voltage variations must be kept in order to permit undistorted 100 per cent modulation. Obviously therefore higher efficiency cannot be obtained simply by increasing the unmodulated a-c component of plate voltage because that would make undistorted 100 per cent modulation impossible.

Doherty has met this problem from two angles. First, he has arranged a circuit such that two tubes carry unequal parts of the load. Tube 1 operates continuously and essentially is the only tube to operate during the condition of unmodulated carrier and during the negative peaks of modulation. Tube 2 is essentially out of operation during the above conditions and comes into the picture only during

the positive peaks of modulation when additional peak power is needed.

Second, the plate circuit is so arranged that the load impedance facing Tube 1 is equal to $2R_p$, (R_p being the normal load into which the tube should operate for maximum output), during the unmodulated carrier condition. A further condition of design for the plate circuit is that on the positive peaks of modulation the load impedance facing Tube 1 shall decrease, until on the positive peak of 100 per cent modulation the load impedance shall equal R_p .

The latter condition results in a rather peculiar situation. Tube 1 is operated Class B. During unmodulated carrier, given positive grid voltage variations result in given peak plate current pulses which in turn, through load impedance $2R_p$, produce plate voltage variations across the load circuit. Since $Z_{1oad} = 2R_p$, for given peak plate current the output voltage is high and can be made sufficiently high that good efficiency is obtained.

On the positive modulation peaks the grid voltage of Tube 1 increases with a corresponding increase in plate current until on the positive peaks of 100 per cent modulation the plate current has been doubled. In an ordinary linear amplifier this would result in doubling the r-f output voltage. However in this case the circuit is such that on the positive modulation peaks $Z_{1oad} = R_p$, a reduction of one-half. Since I_p has been doubled and Z_{1oad} decreased by one-half, E_p is unchanged.

With unmodulated carrier, (I considered unity).

$$\text{Power Output} = I^2(2R_p) = 2I^2R_p = 50\text{kw}$$

At 100 per cent modulation

$$\text{Power Output} = (2I)^2R_p = 4I^2R_p = 100\text{kw}$$

Thus tube 1 at 100 per cent modulation is delivering TWICE AS MUCH POWER TO THE LOAD WITHOUT ANY INCREASE IN PLATE VOLTAGE VARIATION.

The circuit and voltages of Tube 2 must be such that on the positive peaks of 100 per cent modulation Tube 2 is also delivering power to the load equal to twice the carrier power — in this case 100 kw. Then the peak power in the load will be equal to four times the carrier power, the basic requirement for 100 per cent modulation.

In Tube 1, although the plate voltage peak amplitude is essentially flat during the positive modulation alternation, the plate current rises as explained above. On the negative modulation alternation both plate current and plate voltage fall in accordance with the modulation voltage because Z_{1oad} is essentially constant at $2R_p$. If modulation is sinusoidal, then the modulation component of plate current in Tube 1 should be sinusoidal.

Tube 2 is biased much more negatively than is Tube 1, the additional bias being such that in theory Tube 2 contributes no power output at the carrier level and contributes power to the load only during the positive modulation peaks. (Actually it is not attempted to make such a fine dividing line between the output of the tubes to the load and Tube 2 is allowed to contribute a small amount of carrier power.) Thus the modulation component of Tube 2 plate current is in the form of a positive half-cycle.

The r-f output current and voltage envelope relations in Tubes 1 and 2 are shown in Fig. 1. These envelopes represent the current and voltage contributions of the respective tubes appearing at the tuned

plate circuit and hence at the load. It is seen that in Tube 1 I_p is sinusoidal throughout the modulation cycle while E_p is sinusoidal on the negative modulation alternation and flat on the positive alternation. In Tube 2 E_p is sinusoidal throughout the cycle but the voltage between time 1 - 2, 4 - 6 and 8 - 9 is contributed by the tank circuit and Tube 1 because during those intervals E_g in Tube 2 is negative beyond cut-off and no plate current flows. Thus Tube 2 operates at very high Efficiency.

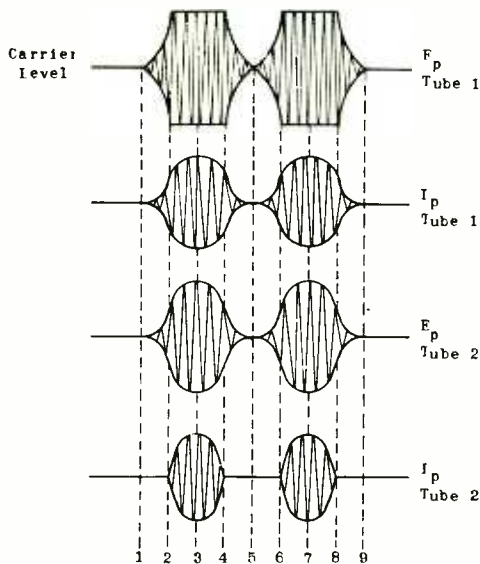

Fig. 1.—The output current and voltage relations in Tube 1 and 2.

It particularly should be noted that the peak amplitudes of E_p and I_p in the two tubes are identical at 100 per cent modulation so at those instants the two tubes contribute equal amounts of power to the load, the peak contribution of each being double the carrier power, the proper condition for 100 per cent modulation.

On first thought it might be assumed that such a condition of operation could be obtained by means of bias adjustment only. That is not true however because a leading factor in this amplifier operation is the variation of the load impedance of Tube 1 from $2R_p$ to R_p when the positive modulation alternation varies the output from unmodulated carrier to 100 per cent peak modulation. The variation of load impedance is accomplished by means of an "impedance inverting network"

The fundamental impedance inverting network is shown in Fig. 2. This circuit has several important characteristics:

1. When voltage E is applied to one end of the network, current I exists at the other end of the network. Regardless of the type of terminating impedance, I will lag 90° behind E .

2. When the network is terminated by R as shown, E_r will lag 90° behind E because the voltage across R must be in phase with I and I lags 90° as stated in (1). This phase relation exists REGARDLESS OF THE VALUE OF R .

3. The input impedance of the network is a resistance INVERSELY PROPORTIONAL TO R and equal to X^2/R . For example, if each component $X = 1000$ ohms and $R = 500$ ohms, then the input impedance = $1000^2/500 = 2000$ ohms. If R is increased to

1000 ohms, input $Z = 1000^2/1000 = 1000$ ohms. Thus when R is doubled, input Z is decreased by one-half. At the same time, according to (2),

volts and lags E by 90° .

With these facts in mind, let us see how the circuit of Fig. 2 can be used in a high efficiency

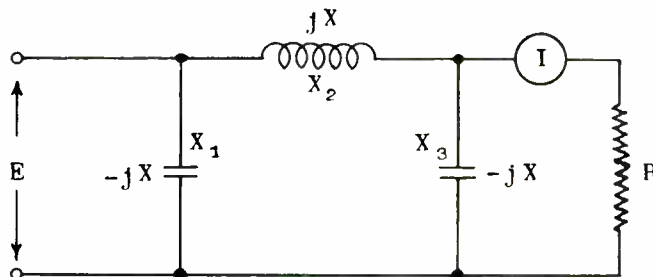

Fig. 2.—A fundamental impedance inverting network.

the phase relation between E_r and E is 90° for both or any intermediate conditions.

The principle on which the π network operates is simple. Designating the shunt elements as X_1 and X_3 and the series element as X_2 , the following conditions exist when load resistor R is connected across X_3 : As R is increased, approaching infinity as a limit, X_2 and X_3 constitute a series resonant circuit, the net effect of which is to short-circuit X_1 and the system as viewed from the "sending" end; as R is decreased, approaching zero as a limit, X_3 is short-circuited and X_1 and X_2 constitute a parallel resonant circuit whose net effect approaches infinite impedance or open circuit. Therefore, reducing the value of load resistance raises the effective impedance at the "sending" end of the network, and vice versa.

4. The voltage across R due to E is proportional to R and is equal to $-jE(R/X)$. Thus if $X = 1000$ ohms, $R = 500$ ohms and $E = 8,000$ volts, then $E_r = 8000(500/1000) = 4000$

amplifier. Consider the circuit of Fig. 3 in which the impedance inverting network is connected between r-f amplifier Tubes 1 and 2. Assume that these are Western Electric Type 298-A tubes having plate resistance of 1450 ohms. (The d-c plate supply circuit is omitted for simplicity.) Assume that for maximum output the tubes should operate such that $R_L = R_p$ and that the two tubes are simply connected in parallel across the common load R . Then R should equal $R_p/2 = 1450/2 = 725$ ohms.

According to statement (3) above, if each value of X is made equal to 1450 ohms and $R = 725$ ohms, then $Z_{1\text{oad}}$ into which Tube 1 works (assuming that Tube 2 is idle) will be $Z_{1\text{oad}} = 1450^2/725 = 2900$ ohms. This is equal to $2R_p$ and will result in highly efficient operation from Tube 1 because the r-f plate voltage variation will be high for a given grid voltage variation.

In accordance with statement (4), $E_r = -jE(R/X)$. Assume that the r-f component of E_p for Tube 1 is 12,000 volts. Then, $E_r = 12,000$

$\times (725/1450) = 6000$ volts, just one-half the voltage at the plate of Tube 1. This is the carrier r-f load voltage and is sufficiently small that it may be doubled on the positive peaks of 100 per cent modulation when the full output of Tube 2 is added.

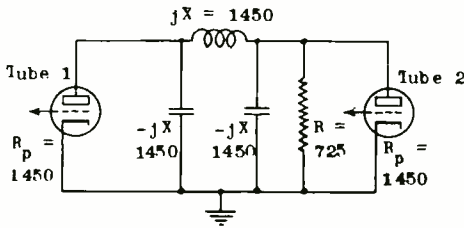

Fig. 3 — An impedance inverting network connected between two tubes.

On unmodulated carrier and during negative peaks of modulation, only Tube 1 operates and, since R remains fixed at 725 ohms and Z_{load} for Tube 1 is consequently constant at 2900 ohms, the voltage across R follows the negative modulation of the grid excitation voltage of Tube 1.

When positive modulation occurs a marked change takes place in the circuit operation. For unmodulated carrier and for negative modulation Tube 2 has been inoperative due to the much greater negative bias than that used on Tube 1. On positive modulation the grid excitation increases and, overcoming the large bias on Tube 2, causes Tube 2 to deliver power to load resistance R .

At this point another phenomenon must be considered. This is one which is basic whenever two or more

tubes are connected in parallel into a common load. Consider Fig. 4. Tubes 1 and 2 are identical and connected in parallel. Each tube will deliver maximum power output when $R_L = R_p$. If $R_{p1} = R_{p2}$, then it is customary to make $R_L = R_p/2$ and to state that, since the two tubes are connected in parallel, the combined R_p has been reduced by one-half and R_L must be correspondingly reduced. However SO FAR AS EITHER TUBE INDIVIDUALLY IS CONCERNED, that explanation is neither correct nor adequate. Each tube, to deliver maximum power output, must operate into $R_L = R_p$ FOR THE INDIVIDUAL TUBE. Thus so far as Tube 1, for example, is concerned, R_L must equal R_p and NOT $R_p/2$, and that condition will exist ONLY if the output of Tube 2 equals the output of Tube 1.

When current I_2 from Tube 2 flows in R_L an IR drop is established. This IR drop may be designated E_2 . The current I_1 from Tube 1 also flows in R_L and establishes an IR drop which will be designated

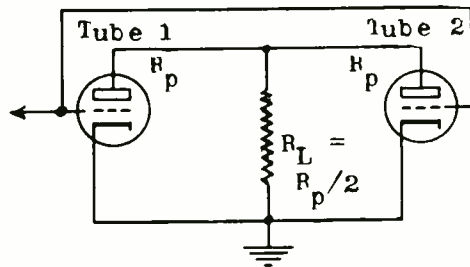

Fig. 4. — Two tubes connected in parallel.

E_1 . THE TOTAL VOLTAGE ACROSS THE CIRCUIT IS $E_1 + E_2$. If $I_1 = I_2$ then $E_1 = E_2$ and $E_T = E_1 + E_2 = 2E_1$ or $2E_2$. The resistance FACING EITHER

TUBE is not E_1 or E_2 divided by its respective current BUT THE TOTAL E DIVIDED BY THE RESPECTIVE CURRENT. Thus, R_L facing tube 1 is equal to $(E_1 + E_2)/I_1$. If $I_1 = I_2$ and hence $E_1 = E_2$, then the EFFECTIVE LOAD RESISTANCE facing either tube is $2R_L = R_p$.

In the operation of the Doherty circuit this condition becomes particularly important. Refer to Fig. 5. It is stated on the diagram that $R_{p1} = R_{p2}$, that $R_L = R_p/2$ and that each value of $X = 2R_L$. Then if Tube 2 is inoperative, due to excessive negative bias and insufficient excitation, from the characteristics of the impedance inverting network Tube 1 looks into a load impedance of $4R_L = 2R_p$ as explained above.

When the excitation to the two tubes increases on the positive alternations of modulation Tube 2 operates. The output current from Tube 2 flows in R_L and, as explained immediately above, the effective resistance of R_L increases. Since the effective load facing Tube 1 varies

til, when the power outputs from the two tubes are equal, $R_L = R_p$ and Z_{load} for Tube 1 also equals R_p .

It would seem that as the effective load impedance on Tube 1 decreases on the positive modulation alternations, the r-f plate voltage E_1 should also decrease. That would be true except for the fact that on the positive modulation alternation the grid excitation voltage rises in the same proportion that the load impedance drops so that the output voltage of Tube 1 remains substantially at the carrier level during the positive alternation. This is shown in Fig. 1.

During the positive modulation alternation the output voltage from Tube 2 adds to the carrier voltage of Tube 1. At the peak of 100 per cent modulation the total voltage across R_L is double the carrier voltage. Since power = E^2/R , the peak power at 100 per cent modulation is four times the carrier power which is the proper condition.

Thus with the voltages, resist-

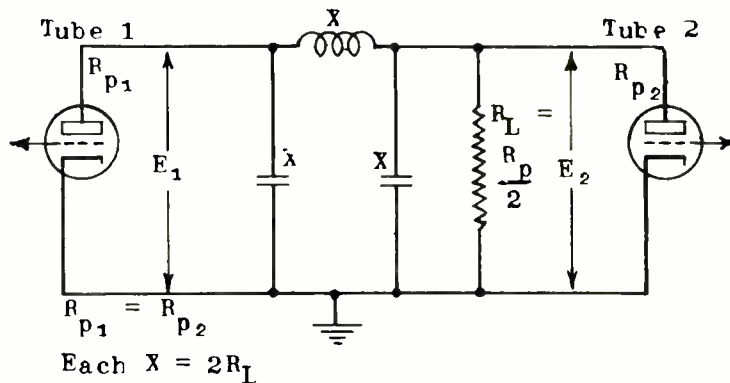

Fig. 5.—A simplified circuit for the Doherty amplifier.

inversely as R_L due to the impedance inverting network, as the effective R_L increases the effective load impedance facing Tube 1 decreases un-

ances and reactances as specified for Fig. 3, with unmodulated carrier and only Tube 1 operating, Power Output = $E^2/R = 6000^2/725 = 50,000$

watts. At the positive peak of 100 per cent modulation, Power Output = $12,000^2/725 = 200,000$ watts

Another factor must now be taken into consideration — the 90° phase shift caused by the impedance inverting network. The network as shown in Figs. 3 and 5 causes the voltage across the load from tube 1 to lag 90° behind the voltage at the plate of Tube 1.

If the grids of Tubes 1 and 2 were simply excited in parallel with different biases, the outputs from the two tubes into the load on the positive modulation peaks would be 90° out of phase. This must be corrected and is done, in a very simple manner, by the use of an impedance inverting network between the two grids which will ADVANCE the phase of the grid voltage on Tube 1 to compensate for the 90° retardation effected by the plate network. Such a circuit is shown in Fig. 6. It is essentially similar in construction and operation to that used in the plate circuit except the positions of L and C are reversed, thus providing a 90° phase displacement in the opposite direction. X may be made approximately equal to R.

The phase relations between the grid and plate voltages of Tube 1 and 2 are shown in Fig. 7. E_p Tube 2 is shown 180° displaced from E_g Tube 2 due to normal amplifier operation. E_g Tube 1 is advanced 90° by the network of Fig. 6 and E_p Tube 1 is likewise displaced 180° from E_g Tube 1. However before reaching the load E_p Tube 1 is retarded 90° by the network of Fig. 3. Thus the

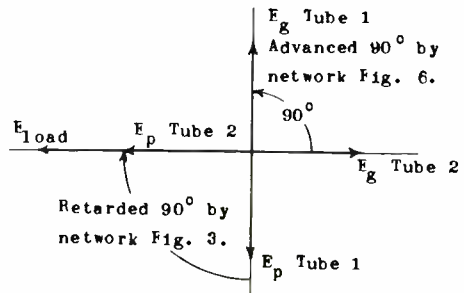

Fig. 7.—The phase relations between the grid and the plate voltages of the two tubes.

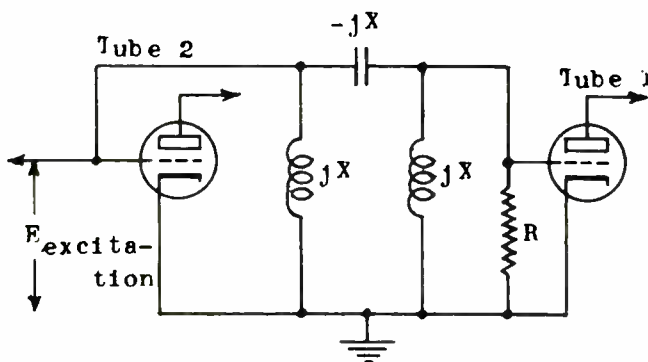

Fig. 6.—An impedance inverting network between the two grids advancing the phase of the grid voltage on tube 1.

output voltages of Tubes 1 and 2 add in phase in the common load circuit.

The first tube operates as a linear amplifier during the carrier and negative modulation alternations. On the positive alternations of 100 per cent modulation the grid excitation voltage theoretically doubles. In practice however such a great increase of grid voltage has not been found necessary to maintain constant output voltage with decreasing load and the large positive voltage has the bad effect of causing excessive grid current. Therefore it is desirable to limit the increase in excitation of Tube 1 to about 40 per cent.

This is done by combining the principles of the grid leak and the impedance inverting circuit as shown in Fig. 6. It has been stated that the voltage at the output terminals of an impedance inverting network is directly proportional to the resistance across the output.

As the grid of Tube 1 is driven highly positive on the positive modulation peaks the flow of grid current in Tube 1 causes a sharp drop in grid-filament resistance. This resistance, being directly across R, decreases the terminating resistance of the network and hence limits the extent to which the excitation voltage of Tube 1 follows the peak excitation of Tube 2. The value of grid leak resistance is not critical and is considerably higher than is ordinarily used in a linear amplifier where excessive grid leak voltage drop would cause distortion by limiting the positive peak modulation grid excitation.

The grid excitation of Tube 1 for a given grid voltage at Tube 2 (see Fig. 6) is equal to $jE(R/X)$.

The values of L and C necessary to obtain the desired values of X as determined for the plate and grid networks above are calculated by the simple formulas,

$$-jX = X_c = \frac{1}{2\pi FC}$$

$$jX = X_L = 2\pi FL$$

$$C = \frac{1}{2\pi FX_c} \quad L = \frac{X_L}{2\pi F}$$

PRACTICAL CIRCUITS.—In all Class B amplifiers it is desirable — in fact, necessary — to employ tuned tank circuits in order to obtain a sufficiently large kva/kw ratio adequately to suppress the harmonics inherent to this type of amplifier. Also in practice the plate load resistance is the antenna which will be so coupled to the plate tank circuit as to supply the proper loading effect.

Thus in place of the capacitors in the impedance inverting network of the plate circuit of Tube 1, tuned tank circuits may be used as shown in Fig. 8. Each parallel tank circuit is tuned so as to represent the proper amount of capacity reactance at the operating frequency. To do this, the tank must be tuned to a resonant frequency somewhat LOWER than the operating frequency. It will then be operating at a frequency higher than its resonant frequency and will accordingly represent effective capacitive reactance at the operating frequency. Coil L may be used to carry the d-c plate voltage from Tube 1 to Tube 2.

The network between the two grids is built up in a similar manner

except that coil L is replaced by the proper amount of capacity and the tuned circuit is adjusted to resonate at a frequency HIGHER than the operating frequency and correspondingly represents inductive reactance across the circuit.

In the case of a high power transmitter the resistance load R will almost invariably represent a transmission line to the antenna. Thus it will be necessary to arrange the circuit L_3C_3 in such a manner as to permit proper coupling to such a line. Ordinarily this will be done

impedance inverting circuit.

It is seen that the plate voltage (+18,000) is fed to Tube 1 through L_2 thus eliminating the necessity for a second plate r-f choke, load resistor R of Fig. 8 is replaced by the transmission line at the bottom of Fig. 9. L_3C_3 makes up a harmonic filter which is tuned to the third harmonic of the operating frequency. C_5 also forms the capacity coupling section of the Tube 2 plate tank circuit by means of which the transmission line impedance is properly coupled so as to represent the

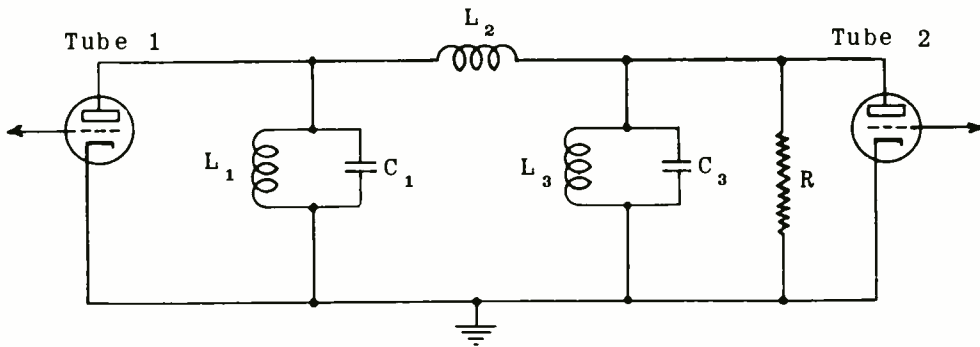

Fig. 8.—Employing tuned tank circuits in place of capacitors for the impedance inverting network.

by capacitive coupling through some type of harmonic suppression circuit.

Fig. 9 illustrates the actual Doherty high efficiency r-f power amplifier circuit as used in the Western Electric 50 kw transmitter Type 407A. Comparing with the fundamental circuit of Fig. 8: L_1C_1 of Fig. 9 is the plate tank circuit of Tube 1 as in Fig. 8. L_3C_3 and a portion of the network C_5 represents the plate tank circuit of Tube 2 as shown by L_3C_3 in Fig. 8. L_2 of Fig. 9 is represented by L_2 of Fig. 8 and is the inductive member of the plate

correct resistance load across the impedance inverting network.

The 90° grid voltage phase shift is accomplished by means of capacitor C_2 and the tuned grid circuit L_4C_4 . The 90° phase relation between the grid voltages on Tubes 1 and 2 is obtained when the inductive susceptance of L_4C_4 equals the capacitive susceptance of C_2 . Coils L_6 and L_7 neutralize the capacity of Tubes 1 and 2 respectively by combining with the tube capacities to form parallel resonant circuits at the operating frequency.

CIRCUIT ADJUSTMENTS

Contrary to general opinion, the adjustments of the Doherty high efficiency amplifier are not at all difficult. In the commercial transmitter, the circuit of which is illustrated schematically in Fig. 9, a standard adjustment procedure is outlined and will be explained below. The following apparatus is re-

quired; Cathode Ray oscilloscope; radio frequency bridge arranged for measuring both series and parallel components of grounded impedances. Preliminary adjustments are made with the plate voltage removed.

FILTER ADJUSTMENT.—The first circuit to be adjusted is the harmonic filter L_5C_6 . C_6 is fixed at the factory for the particular operating frequency and only L_5 need be adjusted. First disconnect the two

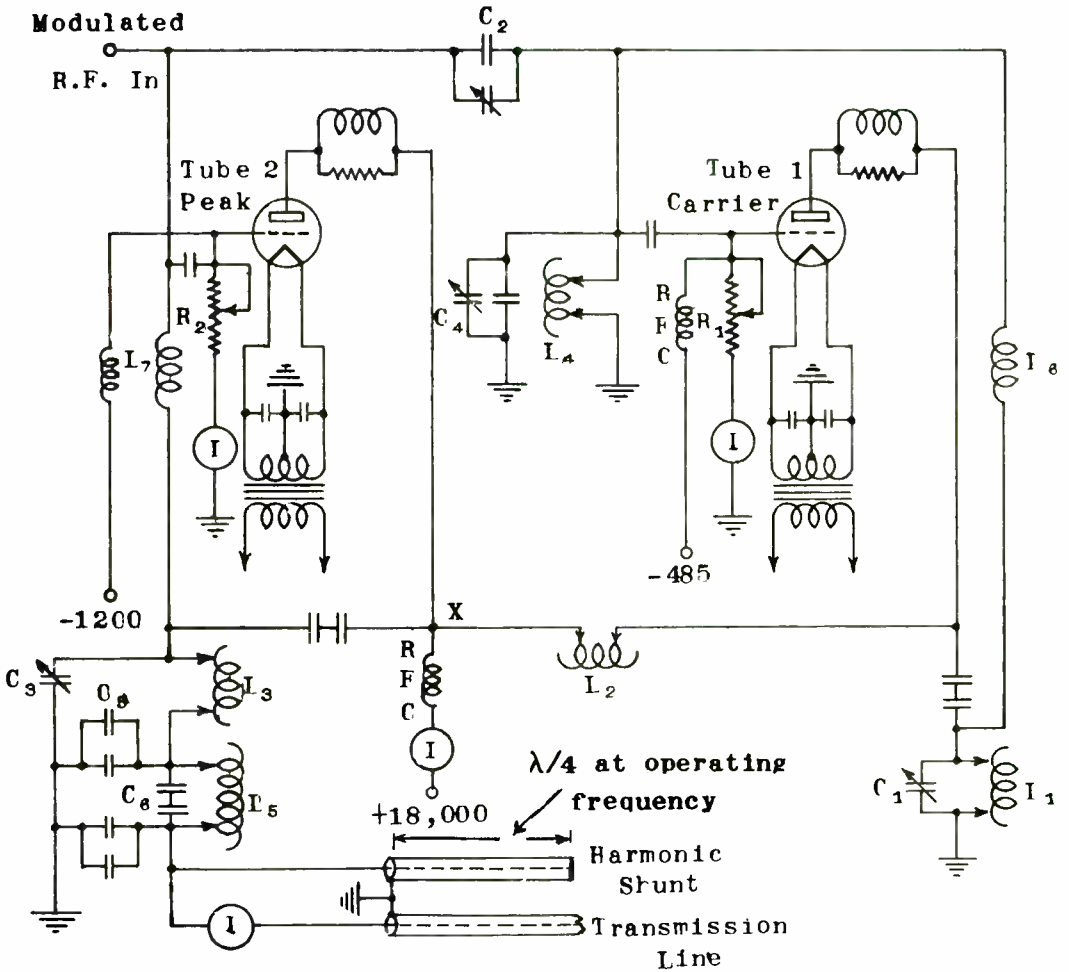

Fig. 9.—The actual Doherty high efficiency r-f power amplifier circuit.

transmission lines at one end and L_3 at the other end. Substitute for the transmission lines between L_5 and ground a 62.5 ohm non-inductive resistance. Connect the bridge, arranged for measuring either series or parallel components of grounded impedances, to the other end.

L_5 should be adjusted to give a series or parallel input resistance to the filter of 75 to 80 ohms, with reactive component of not more than 10 per cent. This adjustment is made at the operating frequency. After completing this adjustment reconnect the filter to the transmission lines and to L_3 .

LOAD IMPEDANCE ADJUSTMENT.—The next adjustment is for the load impedances for Tube 1 and 2. The desired load impedance for the combined output of the two tubes as measured at point X is approximately 600 ohms, and the impedance facing the plate of Tube 1 for unmodulated carrier condition is approximately 2800 ohms. The adjustments should be made by means of a radio frequency bridge arranged to measure PARALLEL COMPONENTS OF GROUNDED IMPEDANCES and should be made with the water system filled so that the resistance of the water column will be present just as in normal operation.

As a preliminary adjustment, select the taps on Coils L_1 and L_3 so that the reactance of each is approximately 1200 ohms and adjust the inductance L_2 for reactance of approximately 200 ohms. This may be done by means of a simple inductance formula as discussed in an earlier assignment. Then ground the Tube 1 side of L_2 and, WITH THE R-F BRIDGE CONNECTED AT THE PLATE OF TUBE 2, adjust L_3 until the resistance measures 600 ± 20 ohms. Capacitor C_3 is then adjusted for parallel resonance

at the operating frequency, that is, until the reactance is infinite and the impedance is purely resistive.

Next, remove the ground from L_2 and connect the bridge to measure the parallel impedance between the plate of Tube 1 and ground. The parallel resistance at this point is controlled entirely by L_2 and should be adjusted for a value of 2800 ± 50 ohms. Then adjust capacitor C_1 until the parallel reactance is infinite, changing the taps on L_1 if necessary to allow this adjustment to be obtained with C_1 at a fairly low capacity setting. (It should be noted that in practice the impedance facing Tube 1 under carrier conditions is made approximately 4.5 times the normal load impedance of both tubes at peak output.)

GRID CIRCUIT TUNING.—The grid circuit tuning consists of adjustments to R_1 and R_2 , C_2 and L_4C_4 . First adjust R_1 to 308 ohms and R_2 to approximately 1000 ohms. R_2 serves simply as a grid leak for the peaking tube and can be quite high because with the excessively large negative bias voltage grid current flows only on the highest excitation peaks. R_1 serves as a loading resistor for the grid impedance inverting network.

C_2 is called the "inter-grid coupling capacitor" and consists of a .0003 μ f fixed capacitor with a 160 μ mf variable capacitor as a trimmer. (.0003 μ f is correct for stations in the vicinity of 1000 kc/s. C_2 may have different capacity for other frequencies.) This capacitor is normally set at mid-scale and the 90° phase relation between the two grids obtained by adjustment of L_4C_4 .

Proper adjustment is obtained by the use of a cathode ray oscillo-

scope. One pair of deflection plates is connected to the grid of Tube 1 and the other pair to the grid of Tube 2. The object is to adjust $L_4 C_4$ until this circuit represents an inductive susceptance equal to the capacitive susceptance of capacitor C_2 . When this adjustment is obtained the excitation voltages at Tubes 1 and 2 will differ in phase by 90° and that phase difference will be indicated by an elliptical pattern on the screen of the cathode ray tube with the axes of the ellipse horizontal and vertical. In this adjustment, the taps on L_4 are arbitrarily set and C_4 varied over the scale until an adjustment is found. If best adjustment is found with minimum capacity at C_4 , the inductance of L_4 should be reduced, and vice versa.

After grid circuit tuning is completed, the plate circuit of the preceding modulating amplifier should be readjusted for minimum plate current.

FINAL AMPLIFIER TUNING.— At this point plate voltage should be applied to the final stage, and after a reasonable warming-up period the plate voltage should be raised to 16,000 or 18,000 volts and excitation voltage applied until plate current of about 2 amperes flows. Check the 90° grid voltage relation and readjust if necessary.

Next check the phase relation between the plate voltages of the two tubes. Adjust capacitor C_3 until a 90° phase difference is obtained. This is the only control which affects the relative phases of the plate voltages. (It should be noted at this point that in the WE Type 407A transmitter jacks are provided for connecting the oscilloscope into the plate and grid voltage positions on the two tubes. Pick-up

coils and taps are provided to deliver safe and proper r-f voltages to the jacks for test purposes.) Next check the plate circuit tuning of the modulating amplifier as some readjustment may be necessary with the power amplifier in operation.

Next connect the cathode-ray oscilloscope between the plate and grid of Tube 1. Adjust capacitor C_1 until the oscilloscope shows a straight line pattern. This will indicate a perfect 180° phase relation which is proper between the grid and plate of an amplifier tube. Since the grid and plate voltages of Tube 1 differ in phase by 180° , the two grid voltages are 90° different in phase, and the two plate voltages are displaced by 90° , then the grid and plate voltages of Tube 2 must differ by 180° . This may be checked by the oscilloscope.

Next adjust the excitation voltage until the output, as indicated by the transmission line ammeter, is 50 kw. Since $\text{Power} = I^2 R$, $I = \sqrt{P/R}$ where R is the impedance of the transmission line. The line, when properly terminated, represents the actual load resistance. For a concentric line having an impedance of 62.5 ohms, the transmission line current should be 28.3 amperes.

In the transmitter under discussion, for unmodulated 50 kw carrier, the plate current of Tube 2 should be between .5 and .8 ampere, and the total plate current to both tubes should be between 4.55 and 4.7 amperes. The plate current of Tube 2 may be increased or decreased by changing the setting of the inter-grid coupling control C_2 . If this is done, C_4 must be readjusted slightly to maintain the 90° phase relation.

ADJUSTMENTS FOR MODULATED OUT-

PUT.—As shown in an earlier assignment on modulation, the sideband power for 100 per cent modulation is equal to 50 per cent of the unmodulated carrier power so that when modulation is complete the total r-f power in the antenna is 1.5 carrier power. (This should not be confused with the PEAK power output which, on the positive peaks of 100 per cent modulation is four times the carrier power.) Since $I = \sqrt{P/R}$, with a fixed value of R (the antenna resistance) the antenna current is a function of \sqrt{P} , and at 100 per cent modulation $I = \sqrt{1.5}$ Carrier I. Thus for 100 per cent undistorted sinusoidal modulation the antenna current should be increased 22.5 per cent or to 1.225 carrier current.

Before the development of inverse feedback as a means of canceling out distortion which might develop in the final linear amplifier, it was necessary to carefully adjust for the condition as outlined above if serious distortion were to be avoided. Using inverse feedback it is possible to operate the final amplifier with reduced filament temperature and hence into the region of saturation plate current without the development of serious distortion and with only the result of slightly reduced output at full modulation. Under such conditions the positive PEAK power output during full modulation is limited to something less than four times the carrier power, and since there is no such limit on the negative modulation alternation, this alternation can drive the antenna current to zero.

Since the antenna current can modulate to zero on one alternation but cannot go to double the carrier on the other, the AVERAGE is decreased to below the normal carrier

current. This is called "carrier shift" and without the correcting effect of an inverse feedback circuit would result in serious distortion. With carrier shift and undistorted output due to inverse feedback correction, if the antenna current is allowed to rise to only 1.155 carrier current, this will represent sideband power of .33 carrier instead of .5 carrier and will reduce the amplitude of the transmitted signal only .5 db. Since this decrease is only at 100 per cent modulation, which occurs for only a very small portion of the total time with ordinary program material, the effect of this carrier shift on program broadcasts should be unnoticeable.

Operation with carrier shift is obtained by operating the tubes of the final power amplifier with reduced filament voltage. To facilitate adjustment the engineer should first calculate what antenna or transmission line current he wishes to have at 100 per cent modulation with respect to the carrier current. Assume that for 100 per cent modulation it is desired to have the transmission line current rise to 1.18 carrier instead of to 1.225 carrier. Assume further that for normal carrier output the transmission line current is 28.3 amperes. Then for 100 per cent modulation I should be 28.3×1.18 or 33.4 amperes.

Connect a cathode-ray oscilloscope so that the output wave form may be observed. Modulate the transmitter with an audio oscillator having a good wave form at 400 cycles and increase the modulation until on the downward swing of modulation the r-f current just reaches zero. This adjustment may first be made with rated filament voltage and then the fila-

ment voltage of the two final amplifier tubes alternately reduced .5 volt at a time until the transmission line current rise is reduced to the desired amount. The inverse feedback adjustment is made so that distortion in the r-f envelope is kept within the desired limits.

If the transmission line current rise is LESS than the required amount with final amplifier normal filament voltage, the load impedance of the modulating amplifier should be reduced and the plate circuit tuning of that stage readjusted for minimum plate current. Decreasing the load impedance on the modulating amplifier (within reasonable limits) increases its peak power output, increases the peak excitation of the final amplifier stage, and hence increases the output current rise with modulation, provided the filament emission of the final stage is sufficient to furnish the increased peak power.

Thus the final adjustment for peak modulation consists of calculating the desired peak power output and hence the required r-f current rise; adjustment of the preceding stage (modulating amplifier) to furnish adequate peak excitation; adjustment of the filament voltage of the final power amplifier tubes so that the emission will be just sufficient to furnish the desired peak power output; adjustment of the inverse feedback so that distortion with full modulation does not exceed the desired maximum.

When properly adjusted as outlined above maximum tube life should be obtained together with the required peak power output. This procedure should be repeated monthly so as to assure that the filament voltage is kept just sufficiently

high to supply the required emission.

FEEDBACK

FEEDBACK ADJUSTMENT.—The theory of inverse feedback as a means of cancelling out a large proportion of the noise, hum and distortion which occur mostly in the final power amplifier stage has been discussed in an earlier assignment to which the student is referred for review. Briefly, it consists of taking a small portion of the output of the final r-f stage and rectifying it to obtain the audio components: harmonics due to amplifier non-linearity, hum due to power supply components getting into the final amplifier, and extraneous noise voltages from various sources. This composite voltage is then fed back into an early stage of the audio amplifier in such phase that the component of voltage representing the original signal is 180° out of phase with the original signal voltage at that point. Thus the undesired voltages are introduced into the audio system in such phase, amplitude and wave form that they modulate the transmitter IN OPPOSITE PHASE to the distortion and noise modulation occurring in the final amplifier and hence cancel out such unwanted voltages to any desired extent.

To compensate for this inverse voltage — which also contains the desired signal component — the input signal must be increased over the value without feedback by the amount of feedback. Thus if an original input to the speech amplifier without feedback of -30 db is required for 100 per cent modulation, if 24 db of feedback is ap-

plied the signal input must be increased 24 db or from -30 db to -6 db.

Fig. 10 shows the audio amplifier of the WE 407A transmitter and the manner in which inverse feedback is applied. In this transmitter it is desired to reduce the noise level component in the output to 60 or 65 db below 100 per cent single frequency modulation. (A noise level of 60 db below that of 100 per cent modulation represents a noise voltage only one-thousandth as great as the 100 per cent modulation voltage).

In view of the fact that the practical range of program signal levels as broadcast is only about 35 db, the noise level will be kept to a level at least 25 to 30 db below the minimum program voltage and should thus be unnoticeable at the receiver. It has been found that in this transmitter feedback of approximately 28 db is required to accomplish the desired reduction in noise.

The amount of feedback is measured in a simple manner. First remove the rectifier tube (Tube 6,

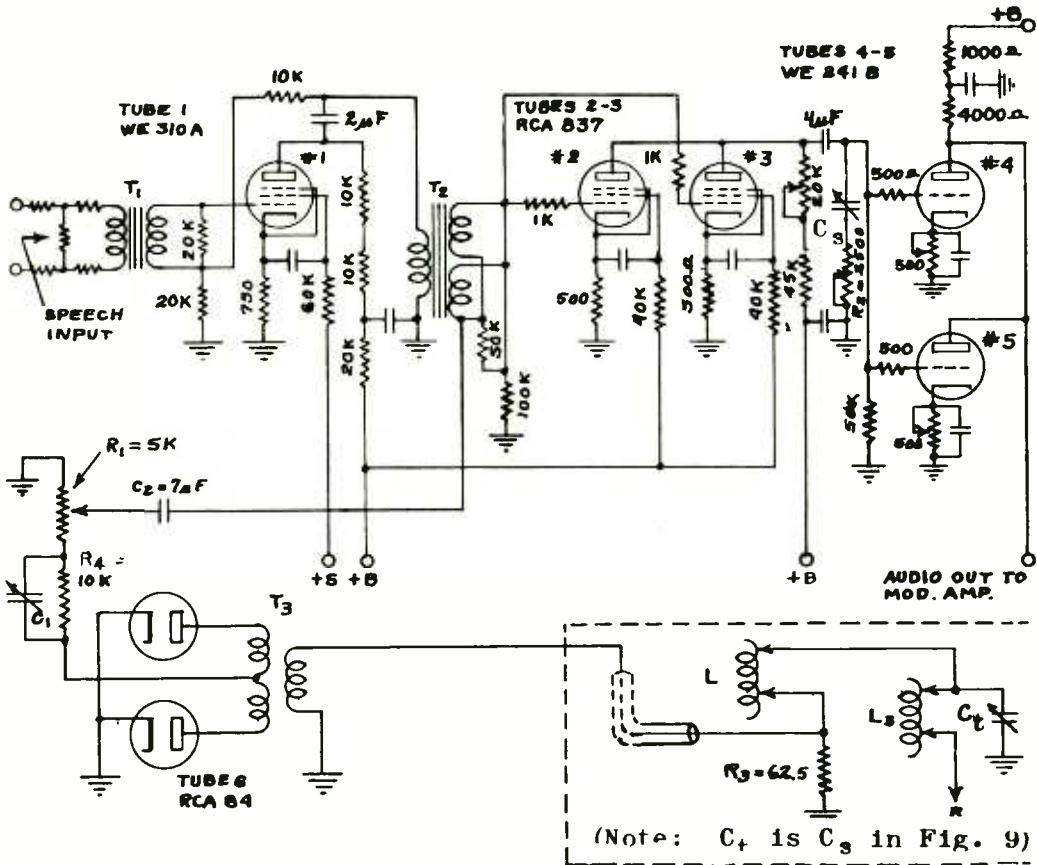

Fig. 10.—The Audio amplifier of the WE 407A transmitter.

Fig. 10) and modulate the transmitter 100 per cent with a single frequency of 400 cycles/second. An audio input level of approximately -32 db should be required. Then replace the rectifier tube and increase the input signal level until 100 per cent modulation is again obtained. The feedback will equal the difference between the two levels. Thus if 28 db of feedback is used, the second level should be $-32 + 28$ or - 4 db.

Before proceeding to the actual adjustment it will be well to first examine the circuit of Fig. 10 so as to become familiar with the general arrangement. The program signal enters the speech amplifier through the "speech input" terminals (upper left), an H type attenuation pad, and an input transformer. The first stage consists of a single pentode (WE 310A) in which a certain fixed amount of inverse feedback is employed. The feedback is from the plate through a 100,000 ohm resistor to the lower end of the secondary of the input transformer, through a 20,000 ohm resistor to ground. This feedback is used to improve the frequency characteristics of this stage and has no bearing on the use of feedback to improve the r-f amplifier characteristics.

From Tube 1 the amplified signal proceeds through transformer T_2 to the grids of the second stage which consists of two RCA 837's in parallel. Note that the primary of T_2 carries no plate current. The output load circuit of Tube 1 consists of 20,000 ohms of resistance and the transformer is used only as a coupling device.

The output of the second stage is resistance-capacity coupled to the third stage which consists of

two WE 241B tubes in parallel. The output of stage 3 is used to grid-modulate two water-cooled tubes in the modulating amplifier. The plate resistance of the second stage is made variable within limits in order to properly load Tubes 2 and 3.

The feedback input circuit is shown in the lower right corner of Fig. 10 in which L_3C_3 refer to similar designation in Fig. 9. A "sampling" circuit consisting of L and R_3 is connected across the output tank circuit of the final r-f amplifier and a portion of the r-f output voltage is taken by transmission line back to the first unit for rectification in Tube 6 (lower left, Fig. 10). A second rectifier (not shown) takes a portion of this signal for monitoring purposes.

The output of rectifier Tube 6 passes through R_4C_1 to the 5000 ohm potentiometer R_1 which is called the "feedback control." C_1 consists of four 50 μ F capacitors, any number of which may be connected in parallel. From here the rectified signal goes through the 7 μ F capacitor C_2 to the lower end of the secondary of T_2 . Across this secondary is connected a 50,000 ohm resistance and between the upper end of the secondary and ground is a resistance of 100,000 ohms. The polarity of the rectified voltage at this point is such that its desired signal component mixes in the transformer winding 180° out of phase with the original signal voltage in that winding. The problem in adjustment is to obtain the desired amount of feedback while at the same time maintaining stable operation of the system. This is done as follows:

First adjust the entire transmitter without feedback until normal carrier and modulated output is ob-

tained without the use of feedback, but neglecting output distortion. Then connect a cathode-ray oscilloscope to show the r-f output, set the "r-f Output" control at zero, and apply normal plate voltages to the transmitter. Set C_1 (Fig. 10) at 50 μF and R at 50 on the dial. Then slowly increase the carrier output of the transmitter by increasing the final stage excitation by means of the "r-f Output" control.

At some point spurious oscillations will probably be indicated on the carrier by the oscilloscope. If this happens it will be necessary to adjust either C_3 or R_2 , or both, (Fig. 10), until oscillations disappear. C_3 consists of five capacitors totalling .02 μF , the smallest being .001 μF and the largest .01 μF , any number of which may be connected in parallel. Then gradually increase the output, making further readjustments of $C_3 R_2$ if necessary, until normal carrier output without oscillation is obtained.

Then modulate the carrier at the single frequency of 400 cycles over the full range of modulation from zero to one hundred per cent, carefully observing the output on the oscilloscope. If spurious oscillation occurs readjust $C_3 R_2$. The setting of the "Feedback Adjustment" R_1 should then be advanced and the above procedure followed until stable operation is obtained with total feedback of 31 or 32 db. This will represent an input level of approximately 0 db at 100 per cent 400 cycle modulation.

Then make a series of observations with unmodulated carrier from zero to normal, and at 50 cycle modulation from zero to 100 per cent. With final adjustment R_2 should be not less than 500 ohms.

At this point, and before distortion measurements are made, C_1 should be readjusted for minimum distortion at the higher audio frequencies.

The tests should now indicate no spurious oscillation with feedback of 31 or 32 db. It was originally decided that feedback of 28 db would be sufficient. Therefore the feedback control should be set back so as to reduce feedback to this amount as will be indicated when input signal level of -4 db will produce 100 per cent modulation at 400 cycles. This allows a stable operating margin of 3 to 4 db.

When major adjustments are to be made to the r-f circuits, feedback should be removed by opening the circuit between the sampling circuit and the feedback rectifier. For minor r-f adjustments it is sufficient to remove the feedback rectifier tube or set R_1 at zero.

It should be noted that almost all circuit adjustments require the use of a cathode-ray oscilloscope. The engineer should become familiar with the use of such an instrument before attempting transmitter adjustments.

THE RCA CLASS B-C POWER AMPLIFIER

CIRCUIT ANALYSIS. — Fig. 11 illustrates the Type B-C high-efficiency power amplifier used in the past by RCA in their 50 kilowatt broadcast transmitters. This circuit is identical in operation to the Doherty amplifier, but the arrangement of apparatus and recommended tuning procedure differ somewhat from the Western Electric circuit previously described.

The RCA Type 50-D transmitter

consists essentially of an oscillator amplifier unit having a power output of 5 kilowatts and a high efficiency power amplifier having rated power output of 50 kilowatts. Modulation is effected in the 5 kilowatt stage immediately preceding the final power amplifier. For emergency operation in case of failure of the 50 kilowatt unit the 5 kilowatt stage can be directly coupled to the transmission line and thus to the antenna so that the unit will operate as a 5 kilowatt transmitter. This is done by means of switch S (top center and right, Fig. 11). Normally, however, the 5 kilowatt unit is used as a modulated r-f driver for the final power amplifier.

The power amplifier employs two Type 898 vacuum tubes, each rated at 100 kilowatt output, one being the carrier tube, and the other the peak tube. These tubes employ 3 phase filaments as shown in the diagram.

As in the circuit previously described, one tube (the carrier tube) operates Class B, supplying the normal carrier output and the negative peaks of modulation. The peak tube is operated with greater negative bias voltage and during carrier conditions supplied very little power output. On the positive peaks of modulation, however, the excess power is supplied by the peak amplifier tube. Under normal carrier conditions the load impedance as viewed from the plate of the carrier tube is approximately 2800 ohms, and the operating efficiency is high because this is approximately twice the impedance into which this tube should operate for maximum power output.

As in the Doherty amplifier, when the peak tube comes into opera-

tion on the positive modulation peaks the load impedance drops. However, this is accompanied at the carrier tube by increased grid excitation voltage with corresponding increase in plate current, so that the decrease in load impedance is compensated for by the increase in r-f plate current and the output VOLTAGE of the carrier tube remains substantially constant during carrier and positive modulation peaks. Variation of load impedance during positive modulation alternations is accomplished by means of an impedance inverting circuit which is essentially a π network consisting of a series inductance, and a shunt capacity connected between each end of the inductance and ground. (See Fig. 2.)

It previously has been shown that in place of the simple capacitors in the π network when used in the load circuit of a transmitting tube it is desirable to use two tank circuits. This is illustrated in the circuit of Fig. 11. Inductance L15 is the series reactive branch of the network; the effective capacity at the carrier tube end of the network is obtained with the plate tank circuit L14, C39. At the peak tube end of the impedance inverting network the effective capacity is represented by the peak plate tank circuit consisting of L4, C14.

If the grids of the two tubes were excited in phase, the r-f plate voltage from the carrier tube, when delivered to the load through the π network, would be, (due to the 90° phase shifting properties of the network), 90° out of phase (lagging) with the output of the peak tube applied to the same load. This is compensated for by the use of a phase shifting network in the grid circuit.

In the circuit of Fig. 11 the

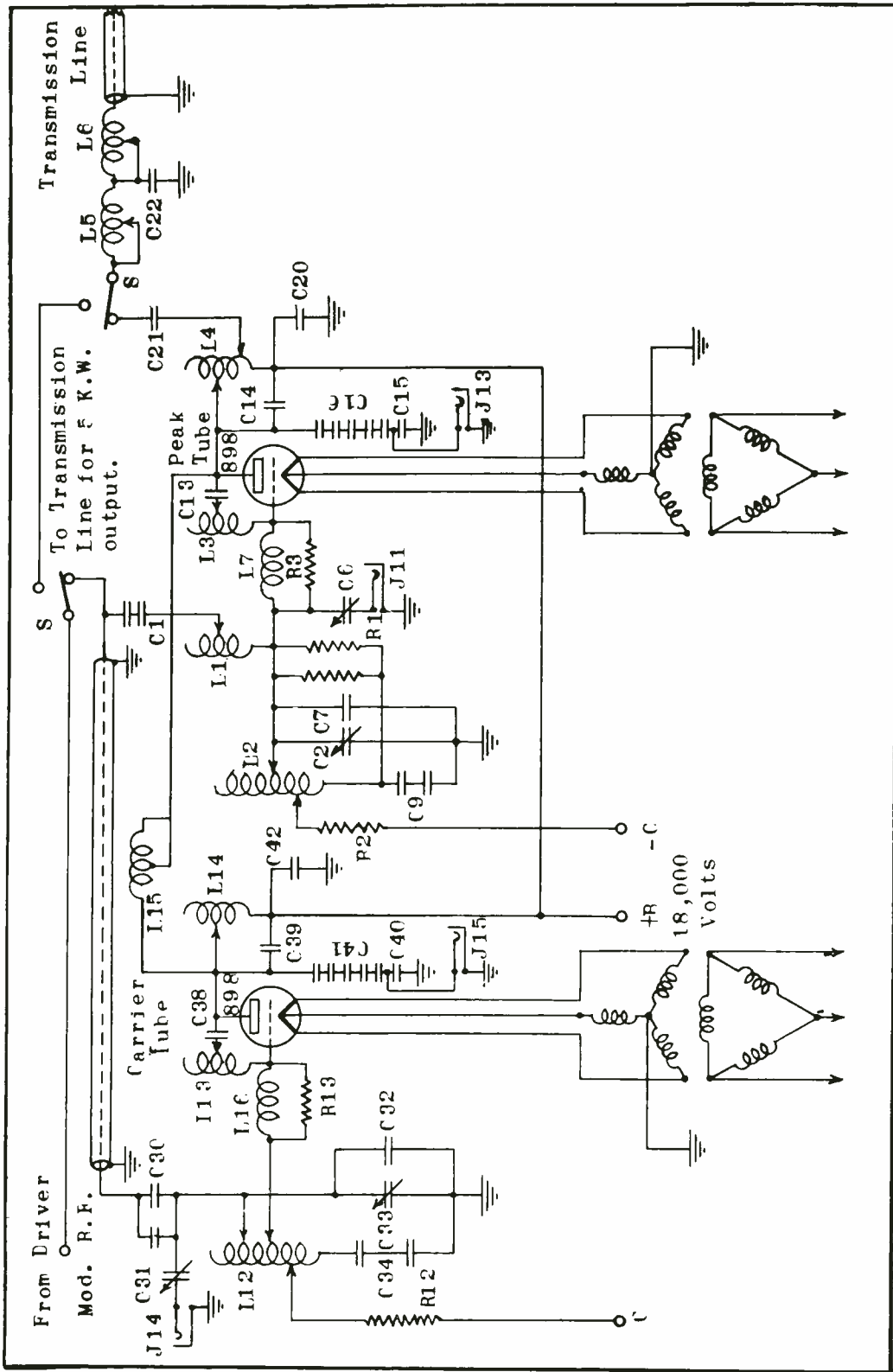

Fig. 11.—RCA Type B-C High Efficiency r-f Power Amplifier.

driver voltage is applied directly to the grid of the carrier tube and through a 90° phase shifting network to the grid of the peak tube. This causes the excitation voltage applied to the peak tube to lag 90° behind the excitation of the carrier tube, and hence causes the output voltage of the peak tube to be in phase at the load with the output voltage from the carrier tube.

As in the case of the plate circuits the π network used between the grids of the two tubes consists of an inductance L1, and two tuned tank circuits. At the carrier tube end of L1 the effective capacity is obtained by means of tank circuit L12, C33, C34; at the peak tube end of L1 the effective capacity is obtained by means of the tank circuit L2, C2, C7 and C9.

It will be noticed that a minor difference exists between the Western Electric and RCA circuits. In the former the phase of the voltage applied to the carrier tube is ADVANCED 90° to compensate for the 90° lag introduced by the plate impedance inverting network. In the latter circuit the excitation from the driver is applied directly to the carrier tube and the phase of the peak tube excitation is retarded 90° to compensate for the retardation of the carrier plate output by the plate impedance inverting network. The result, of course, so far as the output voltages applied to the load circuit are concerned, are identical.

The load resistance for the plate circuit is the transmission line by means of which power is transferred to the antenna. The transmission line as recommended for this transmitter has an impedance of 235 ohms. By means of suitable

coupling to the peak tube tank circuit this appears to the output end of the impedance inverting network as approximately 700 ohms, or one-half the proper load impedance for the two tubes when fully loaded. The transmission line is coupled through a harmonic suppression circuit L5, L6, C22 and blocking capacitor C21 to L4 of the peak tube plate tank circuit. By properly proportioning the coupling to L4 the desired impedance transformation is obtained.

The grid circuit phase shifting network is designed also as a loading circuit for the driver stage. The "sending" end of the grid network is the carrier tube grid tank circuit which functions as a capacity; L1 is the series inductive branch of the network, and the network termination is the peak tube grid tank circuit across which is connected the load resistance R1. R1 is made up of sixteen 2.5 ampere resistors in series having a total resistance of 550 ohms. The effect of this termination with the proper proportioning the π network reactances is to place an equivalent load of 300 ohms at the "sending" end of the grid inverting network as viewed from the load circuit terminal of the driving tube. This low load impedance is necessary in order to properly operate the driver stage so that by simply throwing switch S the driver is properly loaded by the transmission line to function as a 5 kilowatt transmitter.

When used as a driver for the power amplifier the output of the 5 kilowatt stage to be dissipated in R1 is approximately 3.33 kilowatts, based on a potential of approximately 1000 volts r.m.s. across the network input impedance of 300 ohms.

Correct grid excitation for the carrier tube is obtained by tapping down on the associated grid tank inductance L12.

Neutralization of the tube capacities is accomplished by means of L13, C38 for the carrier tube, and L3, C13 for the peak tube. The capacitors in this case are simply blocking capacities to keep the d-plate potential from the grid circuits. Neutralization is accomplished by feeding back a lagging voltage due to the inductance exactly sufficient to cancel the leading voltage sent back through the capacity of the tube itself.

The tube capacity is neutralized by placing a vacuum tube voltmeter across the plate tank circuit with normal excitation applied to the grid but with plate and filament voltages removed. The tap on inductor L13, or L3 as the case may be, is varied until zero or minimum voltage appears across the respective plate tank circuit. Each tube capacity should be tentatively neutralized before final tuning is attempted, and after the circuit has been properly tuned a final check for correct neutralization should be made.

Capacitors C40, C41 between the plate side of the carrier tank circuit and ground are simple capacitor type potentiometers by means of which a part of each tank circuit voltage can be applied to a jack for operation of an oscilloscope in the final tuning process. C16 has capacity of 50 μF and C15 3000 μF , so that the voltage across jack J13 represents only a small portion of the voltage across the tank circuit. Similar conditions prevail across the carrier tube tank circuit potentiometer.

By means of C31, J14, and C6, J11, sampling voltages are obtained from the two grid circuits.

The negative bias applied to the carrier grid is variable between 1125 and 1200 volts.

The grid bias to the carrier tube is applied through 20 ohm resistor R12, and the bias tap on L12. Bias to the peak tube is applied through R2 and the tap on L2. D-C plate potential for the two tubes is applied through the lower end of L14 and L4, respectively, by-passing to ground for the r-f circuits being accomplished through C42 and C20. C42 and C20 have capacity of .01 microfarads and are rated at 20,000 volts.

R13, L16 in the grid lead of the carrier tube, and R3, L7 in the peak tube grid lead are parasitic oscillation suppressors.

TUNING PROCEDURE.—In tuning the power amplifier the following equipment is required. First, a test oscillator which can be accurately adjusted to the operating frequency of the transmitter; second, a cathode ray oscilloscope; third, a radio frequency bridge and the necessary indicating equipment; fourth, a vacuum tube voltmeter. Also miscellaneous resistors, capacitors, etc., to be used in conjunction with the above equipment.

Preliminary tuning of the power amplifier circuit is accomplished with the use of the radio frequency bridge by means of which tank circuits are adjusted to specified impedance; this is followed by a neutralizing adjustment using a vacuum tube voltmeter as the indicating instrument. Final tuning adjustments are then made to obtain correct phasing of the impedance inverting networks as indicated on a cathode

ray oscilloscope connected to the grid and plate circuits through external jacks.

TRANSMISSION LINE TERMINATION.

The first step in the power amplifier tuning procedure is to provide the proper load for the amplifier. The load, of course, is the transmission line and the terminating circuit which includes the antenna. Therefore the tuning job starts with the antenna end of the transmission line, and works back toward the tubes.

First, connect a non-inductive decade box across the antenna end of the transmission line and adjust the decade resistance until the line input impedance, as measured at the transmitter end of the line, is a pure resistance equal to the terminating resistance. This is not a difficult measurement. The approximate transmission line impedance will be known and it is simply necessary to vary the decade resistance, simultaneously measuring the input line impedance, until a condition of pure resistance is indicated by the impedance bridge. This determines the characteristic impedance of the line.

Measure the reactance and resistance of the antenna at the operating frequency, calculate the circuit values required to match the antenna impedance to the transmission line impedance, and adjust the line terminating equipment elements to these values by measurement. All apparatus should be connected exactly as it will be in operating including the tower lighting circuit. These calculations and adjustments have been explained in detail in an earlier assignment, and will not be duplicated here.

Measure the impedance at the

points where the transmission line will be connected and make small corrective adjustments until the observed impedance, looking into the terminating equipment (with antenna connected and r-f meter short-circuited), is equal to the impedance of the transmission line. Then connect the transmission line to the terminating equipment and again measure the input impedance at the transmitter end of the transmission line. It is probable that small corrective adjustments of the terminating equipment will be necessary in order that the "sending end" impedance of the line is exactly as previously measured and a pure resistance.

HARMONIC FILTER.—A low pass filter is used between the transmitter tank circuit and the transmission line for harmonic suppression. Each installation requires an individual design of filter based entirely upon the observed impedance of the line input at various harmonics of the carrier frequency. Harmonic impedance measurements determine whether one or two stages are required, and what type of filter is to be used. In Fig. 11 a T type filter is illustrated. As nearly as possible the input impedance to the harmonic filter when terminated by the correctly adjusted transmission line should be equal to the measured characteristic impedance of the line.

GRID TANK CIRCUIT ADJUSTMENTS.

The following procedure for adjustment of the grid tank circuit is based on the assumption that the values of all fixed capacities have been specified, and that the inductance of L1 has been calculated, but that inductances L2 and L12 are unknown and must be determined by adjustment.

Calculation of the correct inductance for L1 is based on the desired grid-loading resistance values for the peak and carrier tubes. Approximately 275 ohms for the peak side and 300 ohms for the carrier side are the selected values in this transmitter for minimum grid regulation. The required reactance of L1 is therefore the geometric mean of these loading values or 287 ohms. These constants are somewhat arbitrary and maybe varied within reasonable limits to obtain the correct grid-drive ratio.

It will be remembered from the calculations following Fig. 2 that the input impedance of the network is a resistance inversely proportional to R. It also will be remembered from the preceding discussion of this circuit that it is desirable to so load the grid impedance inverting network that the resistance as viewed from the driver stage is 300 ohms. It should be observed that the carrier tube grid connects directly to the same end of the network as does the driver circuit, therefore if the network represents 300 ohms as viewed from the driver it also represents 300 ohms as viewed from the carrier tube grid.

If the resistance on one end of the network exceeds the reactance value of each section of the network, the resistance at the other end of the network will appear proportionately smaller. Therefore with L1 equal in reactance to 287 ohms and the effective resistance as viewed from the carrier grid 300 ohms, the effective resistance as viewed from the peak grid will be 275 ohms, the desired condition.

Before proceeding with the tuning of the peak grid tank circuit, the bus connection between the

carrier input blocking capacity C30 and the carrier grid tank capacity C32 should be grounded to the frame as directly as possible and the bias tap should be disconnected from the peak grid tank inductance L2. The r-f bridge should be connected between the high side of peak grid tank capacity C7 and ground, and adjusted for the shunt method of determining resistance and reactance. The variable tap on L2 then should be adjusted until the bridge indicated zero reactance.

By short-circuiting to ground the carrier grid tank circuit and connecting the r-f bridge as specified, a parallel tuned circuit to ground is formed with L1 in one side of the circuit and the tuned grid circuit of the peak tube as the second side of the parallel circuit. Since L1 is substantially pure inductance, when a condition of zero reactance is obtained the peak grid tank circuit must represent substantially pure capacity equal in reactance to L1.

To complete the preliminary tuning of the peak grid tank circuit the bias tap on L2 is set at the voltage null; that is, at the point where that tap does not affect either the resistance or the reactance indication in the bridge whether it is connected or disconnected. This point will be fairly broad due to the shunt resistance but should be determined as accurately as possible by estimating the center of null section.

To tune the carrier grid tank circuit the bus connection between L1 and L2 should be grounded to the frame as directly as possible and switch S set at the center position so that the bus connecting the peak and carrier grid circuit is discon-

ected from the modulated amplifier. On the carrier grid tank inductance L12 the bias tap should be removed and the variable excitation tap, normally connected to the associated tube grid, should be temporarily tied in parallel with the tap connected to carrier grid tank capacity C32.

The r-f bridge should be connected directly across C32, and L12 varied until the bridge indicates zero reactance. The carrier tube grid tap should then be set at approximately two-thirds the number of turns between the tuning tap and the end connected to the grid by-pass capacitor C34, and the tuning tap on the coil adjusted until the bridge again indicates resonance with the variable grid tank capacity C33 set approximately at its center position. With this adjustment a parallel resonant circuit gain is formed with L1 as the inductive branch and the carrier grid tank circuit as the capacitive branch. The reactance of L1, of course, equals the capacity reactance of the tank circuit.

In the same manner as described for the peak tube, the bias tap should be set at the voltage node on L12 and the ground removed from the bus between L1 and L2. The carrier grid tank variable capacity C33 finally should be adjusted slightly until the bridge indicates resonance.

It particularly should be noted that these two grid tank circuits are not tuned individually to resonance, but instead are tuned to the point where each has effective capacitive reactance (287 ohms) equal to the inductive reactance of L1. Thus, the π network operates under the conditions as indicated for Fig. 2.

PLATE CIRCUIT ADJUSTMENT.—In the following discussion it is assumed that the antenna transmission line and harmonic filter have been properly tuned, and the input impedance of the filter is pure resistance equal to 200 ohms (plus or minus 10 per cent) as measured from the tank side of the antenna coupling capacitor C21, and that the neutralizing inductors have been adjusted for best neutralization. (If an original tune up is being made the neutralizing taps should be set at the approximate center of the adjustment range, and then carefully adjusted by means of a vacuum tube voltmeter after the preliminary tank circuit tuning is completed.)

The first step in the plate circuit adjustment is to adjust L15 to inductive reactance of 1400 ohms as indicated by the r-f bridge. This adjustment should be made with the bridge leads connected directly across the inductor, the unused end turns of the latter being shorted out.

To tune the peak plate tank circuit the high (plate) side of the carrier plate tank capacity C39 should be grounded as directly as possible to the ground side of the carrier plate by-pass capacitor C42, and the r-f bridge should be connected between the high (plate) side of the peak plate capacity C14 and the ground side of the peak plate by-pass capacitor C20. With the transmission line tap set at the center of the peak plate tank inductance L4 the plate tap should then be adjusted for resonance and the effective resistance calculated. The percentage of turns included between the line tap and ground should be varied until the correct resistance is obtained, adjusting

the taps for zero reactance each time before computing the effective resistance. When finally adjusted the peak tank should measure 500 ohms of pure resistance.

With this adjustment, since the carrier plate side of L15 is grounded and the parallel circuit consisting of L15 in one branch and the plate tank circuit of the peak tube in the other branch, is adjusted to resonance as indicated by zero reactance, the peak plate tank circuit must be acting effectively as a capacity. The entire parallel circuit is loaded by the transmission line, with the coupling such that due to the impedance transformation the load between the peak tube plate and ground represents 500 ohms of resistance.

To tune the carrier plate tank circuit the high side of the peak plate tank capacitor C14 should be grounded as directly as possible to the ground side of the peak plate by-pass capacitor C20, and the r-f bridge should be connected from the high side of the carrier plate tank capacitor C39 to the ground side of the carrier plate by-pass capacitor C42. The carrier plate tank inductance L14 then should be adjusted for zero reactance by varying the taps and adjusting the coupling. Again a parallel resonance circuit is formed with L15 representing the inductive branch and L14, C39, serving as an effective capacity having reactance equal to the inductive reactance of L15.

The plate tank circuits in conjunction with inductance L15 now form a π network which is loaded by the transmission line and antenna circuit with the desired impedance transformation accomplished by the tap from C21 to L4.

FINAL TUNING ADJUSTMENT.—After the preliminary tuning adjustment of the grid and plate circuits has been made, the neutralizing adjustment should be checked by means of the vacuum tube voltmeter. In making neutralizing checks, the vacuum tube voltmeter should be connected between the high side of the plate tank capacitor and ground (frame), and the neutralizing tap varied for minimum voltage across the tank, with full grid excitation but no d-c plate voltage on the power amplifier tubes.

When neutralizing either the peak or carrier tube, the opposite side of L15 should preferably be grounded, and the load disconnected. This places L15 in parallel with the tank circuit of the tube to be neutralized. From a previous adjustment, L15 will be in parallel resonance with the tank circuit, and thus as high an impedance as possible will be placed in series with the plate of the tube. This will tend to increase the reading of the vacuum tube voltmeter connected across the tank, and thus increase the sensitivity of the neutralizing adjustment.

If an original tune up is being made it will be necessary to repeat all of the foregoing adjustments of the grid and plate circuits and then re-check the neutralizing adjustment before proceeding to the final tuning. The reason for this is that until the tube capacities have been properly and accurately neutralized, stray capacities will exist which will slightly affect the tuning of the plate and grid tank circuits.

To make final tuning adjustments, connect the cathode-ray oscilloscope between the grid and plate of the carrier tube, (through

front panel jacks), apply excitation voltage and bias the peak tube to cut-off using maximum bias. Adjust the carrier plate tank inductance L14 until a straight line (closed figure) is observed on the oscilloscope screen. This indicates that the grid and plate voltages are exactly 180° out of phase.

Transfer the oscilloscope to the peak grid and plate jacks and adjust the peak bias for normal plate current. Then adjust the peak grid variable capacitor C2 until a straight line figure is obtained. This will indicate that the peak tube grid and plate voltages are 180° out of phase.

A final check should be made on the phase relation between the grid and the plate voltages of the carrier tube. If the tuning is correct, the oscilloscope should show a straight line.

Next connect the oscilloscope between the two grid jacks; the indication on the screen should be a true ellipse, the major axis of which should exactly coincide with the straight line pattern obtained by viewing a single grid. The plate-to-plate pattern also should be a true ellipse. The true elliptical patterns indicate a 90° phase relation between the two grid voltages and between the two plate voltages. This, of course, is essential to correct operation of the impedance inverting networks.

If the grid-to-grid ellipse shows an abnormal amount of harmonics (as indicated by multiple waves in the pattern) the grid excitation tap may be too low on the carrier grid tank inductance L12. The amplifier is likely to become unstable under these conditions or to produce abnormally high audio

distortion components. Readjustment of the grid tap to eliminate this condition may require a lowering of the resistance value of the peak grid loading resistor R1 to re-establish the correct grid drive ratio between the peak and carrier tubes. The tabulation of normal instrument readings (plate and grid currents) as listed in the manufacturer's instruction book will be found useful as a guide in obtaining correct drive and efficiency for optimum operating conditions.

FEEDBACK CIRCUIT.—Complete overall feedback is provided in the RCA 50-D transmitter. A capacity potentiometer is connected across the output of the harmonic filter immediately ahead of the transmission line and from a tap on this potentiometer is taken the modulated r-f signal voltage to be applied to the feedback rectifier.

The feedback rectifier consists of four RCA Type 836 high-vacuum rectifier tubes connected in parallel, the output being delivered to a resistance circuit. Suitably tapped along this resistance network is a transmission line which carries the rectified audio component back to the input of the first audio amplifier in the exciter unit. Here the signal passes through a low-pass filter, $L_1 C_1 C_2$, designed to remove any trace of radio frequency component, and then to R_1 , a 100 ohm potentiometer which serves as the feedback control. The circuit arrangement is shown schematically in Fig. 12.

The amount of feedback can be measured very easily if an accurately calibrated input gain control is available. First, using feedback, modulate the transmitter to some arbitrary level (preferably not

greater than 75 per cent to avoid distortion which may be quite severe at high percentages of modulation when no feedback is used). Then disconnect the feedback lead at the

excessive, oscillations will be generated at or above certain percentages of modulation. Spurious high- or low-frequency oscillations may develop as the result of r-f

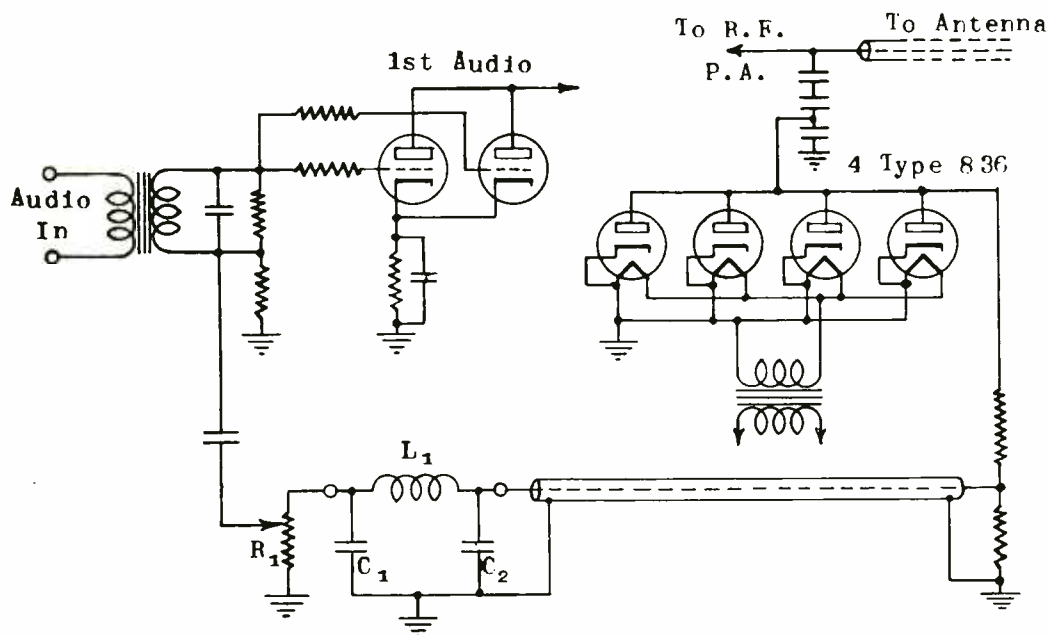

Fig. 12.— Feedback Circuit in the RCA 50-D Transmitter.

filter input (L_1) and decrease the signal input level until the same percentage of modulation is obtained. The difference between the two input gain control settings will be the amount of feedback in decibels.

In making these measurements, care should be taken that the antenna power does not vary appreciably, since a change in antenna power is a change in overall gain and consequently a change in the amount of feedback.

With the use of a large amount of overall feedback, certain precautions must be taken to insure correct performance. If feedback is

pickup in the audio circuits or erratic distribution of ground currents.

At the same time the maintenance of a high degree of feedback is desirable for three principal reasons: First, to provide stable and permanent carrier noise reduction not possible by any other means; second, to reduce audio frequency distortion to a minimum; third, to reduce the undesirable effects of "beat frequency" distortion products falling outside the useful audio range. The latter condition requires that distortion of the higher frequency audio components be reduced to a minimum.

Thus in the final adjustment of the transmitter it is desirable to use as much feedback as possible while maintaining stable operation over the entire audio frequency band and up to 100 per cent modulation.

GENERAL CLEANING IN R-F POWER AMPLIFIERS.—Certain cleaning precautions become more and more important as the power output of a transmitter is increased. Modern 50 kw transmitters employ d-c plate voltages in the order of 18,000 volts, the instantaneous voltages of course being much higher at high percentages of modulation. Thus flashovers are more frequent in the power amplifiers of such transmitters and the effects of dust and dirt on insulators and other surfaces are of increased importance.

Insulators and bushings should be kept clean at all times. Those parts subject to stress in high voltage d-c fields rapidly accumulate dust particles and may break down if sufficient accumulation develops to cause corona. In trouble-shooting cases where flashovers cannot be readily located, check for internal arcs in the glazed ceramic bushings.

High voltage capacitor plates should be kept clean and free of arc etchings, both for the sake of appearance and to prevent the development of corona leading to flashover.

Horns and sphere gaps should be burnished after heavy arcing has occurred, and their clearance (spacing) checked, making necessary adjustment. If surge-absorbing resistors are part of the gap, check their resistance regularly.

Tube envelopes must be kept clean to avoid possible puncture resulting from bombardment or corona. Tissue paper and alcohol is an effective combination for cleaning

glass.

Plate tank inductances should be cleaned with a dry rag or, if necessary, with very fine sandpaper. Never use liquid polish or steel wool for this purpose. Clamp type connectors must be kept tight at all times to avoid excessive heating.

By proper maintenance schedules and careful check on all transmitter components likely to give trouble, a high percentage of probable trouble can be anticipated and expensive "time off the air" minimized.

RESUME'

The Doherty high efficiency amplifier has been found to be sufficiently advantageous to be useful in transmitters having power rating as low as 1 kw and is so used by the Western Electric Company. Also the RCA class B-C amplifier used in the past has essentially the same advantages and only a minor difference exists between the RCA and Western Electric circuit. The result so far as the output voltages applied to the load circuit is concerned are identical. These amplifiers substantially double the operating efficiency of the carrier tube and all peak tube operation is at high efficiency.

The principal advantage of these circuits in lower power transmitters exists in the practicability of using lower power tubes than would be possible if a conventional linear amplifier were used with low level modulation. This is an important item in the operating cost of a broadcast transmitter. The more efficient operation of smaller tubes also simplifies the tube anode cooling problem and reduces the

overall dimensions of the transmitter.

INDUSTRY ACKNOWLEDGEMENT.—We wish to express our appreciation to RCA Manufacturing Company and Western Electric Company for their cooperation in supplying complete trans-

mitter instruction books, detailed circuits, and engineering information from which the technical data and recommended adjustment procedures as outlined in this assignment were derived.

HIGH POWER BROADCAST TRANSMITTERS

EXAMINATION

1. (A) What are the advantages and disadvantages of low level modulation followed by linear amplifiers?

(B) What are the advantages and disadvantages of high level modulation?

(C) In general terms, how does the Doherty amplifier combine the advantages of the two?

2. (A) Which tube or tubes function when the carrier amplitude increases (outward modulation)?

HIGH POWER BROADCAST TRANSMITTERS

EXAMINATION, Page 2

2. (B) Which tube or tubes function when the carrier amplitude decreases, (inward modulation)?

(C) Discuss the variations in the plate voltage and plate current of the carrier tube.

HIGH POWER BROADCAST TRANSMITTERS

EXAMINATION, Page 3

(D) Discuss the variations in the plate voltage and plate current of the peak tube.

3. (A) What is the fundamental purpose of the Pi network between the plate circuits of the peak and carrier tubes?

(B) Why must the grid circuit of the one tube be energized by a driving voltage 90° ahead of that of the other grid circuit?

HIGH POWER BROADCAST TRANSMITTERS

EXAMINATION, Page 4

4. (A) Describe briefly how the impedance inverting network causes the two tubes at the positive peak of the modulated cycle to see a load resistance that is half of the value seen by the carrier tube at and below the carrier level.

(B) In order for the above to be realized, what should be the actual value of load resistance across the impedance inverting network?

(C) What must be the value of the reactances of the impedance inverting network at the operating frequency?

5. (A) Explain how and why the Pi network is modified in an actual circuit.

HIGH POWER BROADCAST TRANSMITTERS

EXAMINATION, Page 5

5. (B) The harmonic shunt shown in Fig. 9 is a transmission line short-circuited at its far end. It is one quarter wave long at the operating frequency, one half wave at the second harmonic frequency, three-quarter wave at the third harmonic frequency, etc. What harmonics will it tend to short out? Explain.

(C) Why is an additional third harmonic filter required ($L_5 C_6$ of Fig. 9)?

6. (A) How are the tubes neutralized in the circuit of Fig. 9?

(B) How is neutralization checked experimentally? Discuss briefly.

HIGH POWER BROADCAST TRANSMITTERS

EXAMINATION, Page 6

(C) Recall the relationship between the series and shunt reactance arms of the impedance inverting plate network, as called for in 4(C). How is this relationship satisfied by the circuit adjustment of connecting one end of the series arm to ground, and adjusting for parallel resonance between the other end and ground?

7. (A) What is meant by "carrier" shift?

(B) Ordinarily, what serious fault does this indicate?

HIGH POWER BROADCAST TRANSMITTERS

EXAMINATION, Page 7

7. (C) How can this fault be minimized?

(D) How is "carrier shift" obtained in the actual Doherty amplifier?

8. Describe briefly the method of making the feedback adjustment on the Doherty amplifier.

HIGH POWER BROADCAST TRANSMITTERS

EXAMINATION, Page 8

9. (A) What difference is there between the RCA Class B-C Power Amplifier and the Doherty amplifier?

(B) What is the method of obtaining plate and grid sampling voltages in the RCA B-C Power Amplifier?

10. (A) In general, how is the correct phase between grid and plate voltage of the one tube, or between grid voltages of the two tubes, measured?

HIGH POWER BROADCAST TRANSMITTERS

EXAMINATION, Page 9

10. (B) How is the amount of feedback measured in the RCA B-C Power Amplifier?

(C) Why must conductor surfaces at high voltages be kept smooth?

