



SECTION 3

**SPECIALIZED BROADCAST
RADIO ENGINEERING**

TECHNICAL ASSIGNMENT

AUDIO FREQUENCY VOLTAGE AMPLIFIERS

Copyright 1947 by
Capitol Radio Engineering Institute
Washington, D. C.

302D

—TABLE OF CONTENTS—

AUDIO FREQUENCY VOLTAGE AMPLIFIERS

	Page
DISTORTION IN AMPLIFIERS.	2
<i>Frequency Distortion</i>	3
<i>Amplitude Distortion</i>	4
(a) <i>Grid Circuit</i>	4
(b) <i>Plate Circuit</i>	4
<i>Phase Distortion</i>	5
ANALYSIS OF VACUUM TUBE AMPLIFIER OPERATION	6
<i>USE OF EQUIVALENT CIRCUIT</i>	6
RESISTANCE COUPLED VOLTAGE AMPLIFIER.	7
MAXIMUM AMPLIFICATION	9
GAIN AT LOW FREQUENCIES	11
GAIN AT HIGH FREQUENCY.	13
EXAMPLE.	14
MULTI-STAGE RESISTANCE COUPLED AMPLIFIER.	19
IMPEDANCE COUPLED AMPLIFIER	20
MAXIMUM AMPLIFICATION	23
EXAMPLE.	23
GAIN AT LOW FREQUENCIES	24
GAIN AT HIGH FREQUENCIES.	26
DESIGN OF IMPEDANCE COUPLED AMPLIFIER	28
ADVANTAGES AND DISADVANTAGES.	28
TRANSFORMER COUPLED AMPLIFIER	29
EXAMPLE.	31
LOW FREQUENCY GAIN.	35
INTERMEDIATE FREQUENCY GAIN	36
HIGH FREQUENCY GAIN	36
AUDIO FREQUENCY TRANSFORMERS.	39
<i>Power Transformer</i>	39
<i>Audio Transformer</i>	40

BROADCAST ENGINEERING

AUDIO FREQUENCY VOLTAGE AMPLIFIERS

Audio frequency amplifiers may be divided, for purpose of study, into three principal groups--resistance coupled, impedance coupled, transformer coupled. The distinguishing feature of each type is the method of coupling between vacuum tubes, the type of coupling used influencing both the type of tube selected and the amount of gain to be expected.

Audio amplifiers may be further divided into two principal classifications as determined by the purpose for which the amplifier is to be used:

1. Voltage amplifiers, in which it is desired to produce the maximum undistorted output voltage for a given input voltage.

2. Power amplifiers, in which it is desired to produce the maximum undistorted power output to drive one or more reproducers or to modulate the R.F. carrier of a transmitter. Such an amplifier usually follows one or more stages of voltage amplification.

Audio amplifiers may also be divided into three principal classifications as determined by the manner in which the vacuum tube is operated:

1. Class A, in which the tube is operated, by means of suitable bias, in the center of the linear portion of the $E_g I_p$ characteristic curve (center of the section between zero grid and the lower bend) and the excitation voltage held within such limits that the grid is not allowed to swing positive.

2. Class B, in which the tube is biased to, or approximately to, the I_p cut-off point, and the grid is normally allowed to swing well positive during excitation, special tubes and circuits being used to minimize harmonic distortion. A Class B audio amplifier is always operated push-pull.

3. Class AB (formerly called Class A Prime) in which the tube

is biased about half-way between Class A and Class B--that is, about half-way between the center of the straight portion of the $E_g I_p$ curve and cut-off. As in Class B, special arrangements are necessary to minimize harmonic distortion. Class AB audio amplifiers always employ a push-pull circuit. Figure 1 shows the three methods of operation.

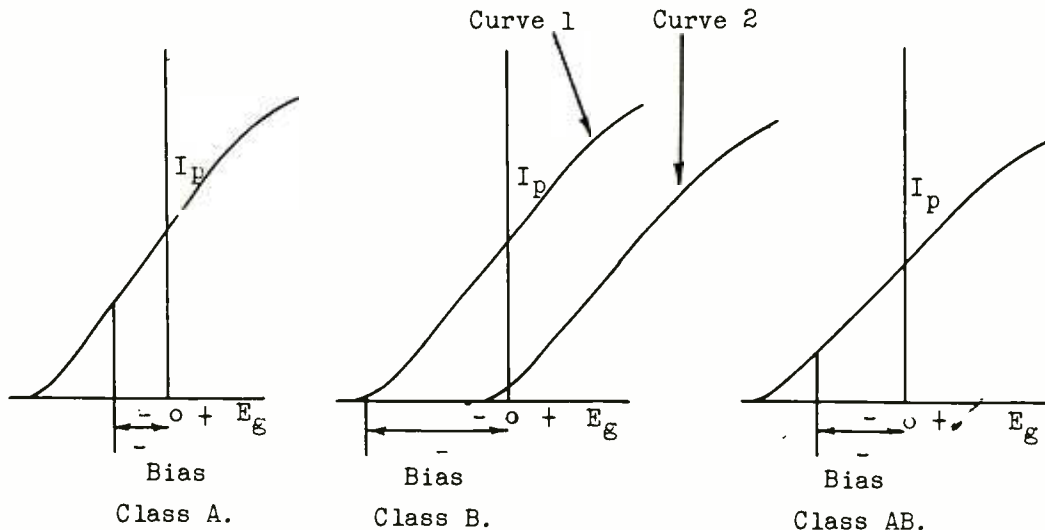

Fig. 1.

Two curves are shown for the Class B amplifier. Curve 1 is for the ordinary triode in which at zero grid bias the plate current is quite high and a large negative bias is required for plate current cut-off. Curve 2 is for a special Class B audio amplifier tube which is so designed that plate current is essentially zero at zero grid bias. The advantage of this has previously been explained in the study of tubes.

In this study of amplifier operation the tube will be assumed to operate Class A unless otherwise specified.

DISTORTION IN AMPLIFIERS

A perfect amplifier is one in which the output voltage is an exact duplication of the input voltage in every respect *except amplitude*. Such perfection is not obtained in practice--all amplifiers introduce some distortion. The object of design is to keep distortion to a minimum within the range of the frequencies to be ampli-

fied.

1. *Frequency Distortion*: This is the unequal amplification of the various frequency components of the input voltage E_s . It is usually important that the audio amplifier provide substantially equal gain over a wide range of frequencies. This is difficult to obtain due to the wide band of frequencies to be amplified, that is, the large percentage variation over the audio frequency band. The audible frequency band is approximately from 16 cycles to 15,000 cycles per second. For most purposes flat amplification from 30 cycles to 8,000 cycles will be adequate, although in some installations the improvement due to the additional band width will justify the additional cost of equipment. In modern broadcast transmitters the audio modulation characteristic is usually made flat from 30 cycles to 10,000 cycles.

The range from about 4500 cycles to about 8500 cycles is particularly important in high fidelity reproduction because it is in this range that the important overtones which distinguish the tone of one musical instrument from another lie. The reproduction of these overtones adds brilliance and "naturalness" to music which otherwise is not a true reproduction of the music as actually played in the studio.

The frequency response of the audio amplifier in most of the present day medium priced radio broadcast receivers is essentially flat from about 100 cycles to 4000 cycles with discrimination against both the very high and the very low frequencies. An example of high frequency discrimination is shown in Figure 2 in which the input voltage contains all the harmonics and overtones *which distinguish one musical instrument from another*. In the output the harmonic frequencies have been lost, only the fundamental frequency appearing in the output circuit. Frequency distortion is due primarily to the variation of the tube load impedance with frequency. For good high fidelity reproduction, frequencies up to about 8,000 cycles are necessary. Thus many of the modern high quality, higher priced receivers being built today incorporate audio amplifiers in which the response is flat up to or beyond 8,000 cycles with the band width adjustable to increase the selectivity when necessary. In many modern public address systems the amplifier is designed for essentially flat gain over a range of from 30 to 10,000 cycles.

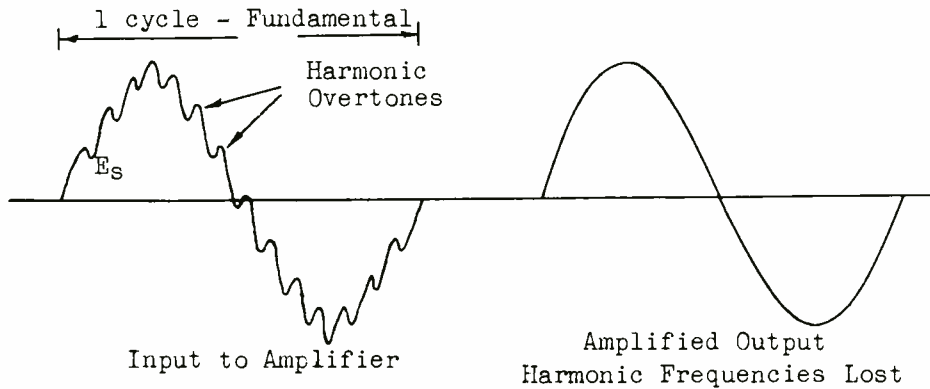

Fig. 2.

2. *Amplitude Distortion:* This is due to the non-linear relation of E and I in the vacuum tube, in either the grid or plate circuit, over the entire variation of signal voltage E_s . The distortion produced by this non-linear E - I relation results in the introduction of harmonics in the output voltage which are not present in the input signal voltage E_s .

(a) *Grid Circuit:* In the Class A amplifier, if the grid goes positive on any point of the E_s swing, non-linear relations of E and I will exist in the input circuit, because when the grid is positive the input resistance of the tube is low; when the grid is negative the input resistance of the tube is very high. Thus over the swing of excitation, E_s works into a non-linear impedance and distortion results. The grid of a Class A amplifier must be held negative over the entire range of excitation voltage to prevent this type of distortion.

(b) *Plate Circuit:* Amplitude distortion may be caused by non-linear relations between E_g and I_p due to a non-linear $E_g I_p$ characteristic curve. To minimize this effect, operate the tube on the straight portion of the $E_g I_p$ curve, keep E_s within the limits of the straight portion of the characteristic curve, properly bias the tube, and make the load impedance Z_L high.

Amplitude distortion introduces into the output circuit frequencies which are not present in E_s . The important frequencies thus introduced are harmonics of the signal frequencies and frequencies equal to one frequency component of the signal plus or minus another

frequency component. The harmonic frequencies introduced are usually harmonious and are ordinarily not very objectionable. This is particularly true in the case of even harmonics. The sum and difference frequency tones are discordant and produce fuzziness and roughness and are especially noticeable in the reproduction of symphonic or choral music. Figure 3 illustrates the manner in which frequencies are introduced by amplitude distortion. An additional source of objectionable distortion is the production of high order harmonics when the grid is allowed to swing positive. This is one reason why in a Class A amplifier the grid swing must be held below that value.

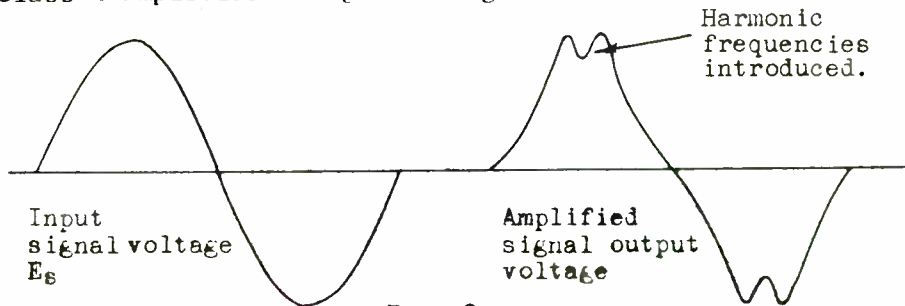

Fig. 3.

In view of the fact that amplitude distortion results in the introduction of harmonic frequency voltages, a measure of the degree of distortion introduced by an amplifier to a signal of a given amplitude level is the percentage of harmonic energy in the output for a sinusoidal voltage applied to the input. The overall performance of the amplifier can be plotted by making such measurements at selected frequencies over the desired audio range.

3. *Phase Distortion:* This is due to the different frequencies being transmitted through the amplifier at different speeds with the result that the phase relations of the various frequency components appearing in the output differ from the phase relations of the same frequency components in the input. This changes the shape of the wave form appearing in the output from its original shape in the input circuit. The amplitudes of the various frequency components are not necessarily changed. Figure 4 shows an extreme case of a signal consisting of a fundamental and third harmonic in which the phase of the third harmonic has shifted 180° in the output. The fundamental component is in dashed line, the third harmonic in dotted line, and the resultant voltage in full line.

In audio reproduction ordinary phase distortion is usually unim-

portant as the latitude of the ear permits the phase to be altered over a wide range without noticeable effects. This is because the actual shift (in time) is small compared with the duration of the signal (sound). Phase distortion becomes important in television and in long distance telephone circuits.

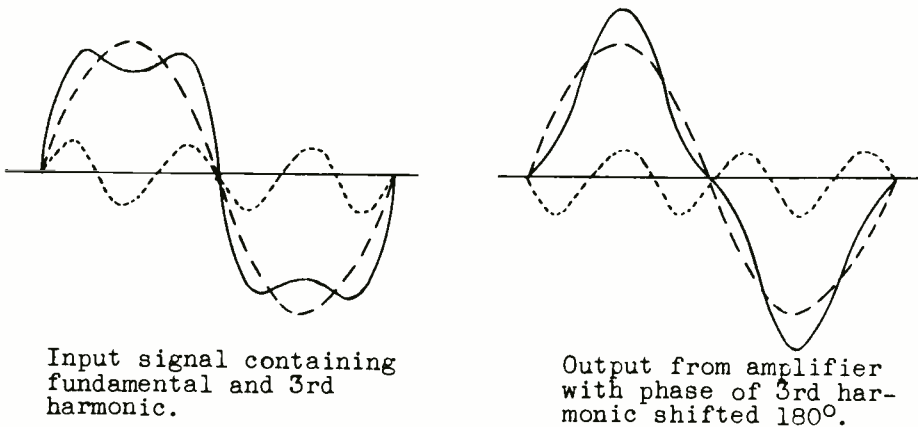

Fig. 4.

ANALYSIS OF VACUUM TUBE AMPLIFIER OPERATION

USE OF EQUIVALENT CIRCUIT: For purpose of analysis the vacuum tube may be considered as a generator having internal resistance of R_p and voltage of $-\mu E_s$. Only the AC components are considered. Figure 5 shows the actual circuit and the equivalent circuit.

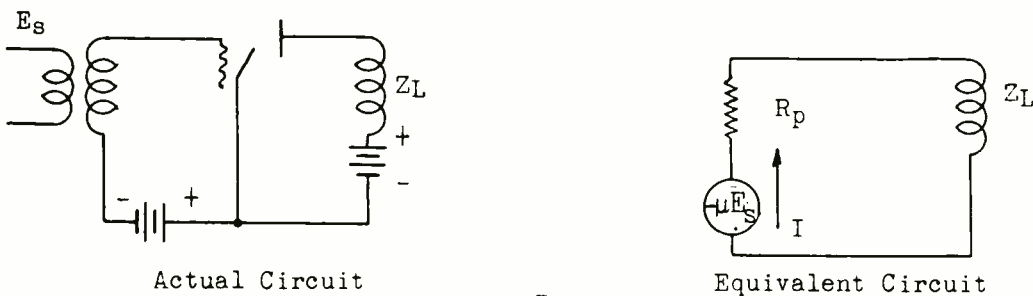

Fig. 5.

The increment of signal E_s on the grid, dE_s , produces a plate current, cathode to plate, equal to I_p . I_p flows through Z_L (load impedance) and produces a voltage drop equal to $-Z_L I_p$. Therefore the application of E_s to the grid reduces the actual plate voltage E by

the amount dE_p which is equal to $-Z_L I_p$. Therefore I_p is the result of the increment of signal voltage dE_s applied to the grid and the reduction $-Z_L I_p$ in plate voltage.

A plate voltage variation of μE_s , produces the same effect on the electron cloud around the cathode as E_s , therefore the tube operating with excitation may be considered as a generator supplying a voltage $-\mu E_s$ directly in the plate circuit between cathode and plate. The negative sign is due to the fact that the grid voltage E_s and plate voltage μE_s are 180° out of phase.

Inspection of Figure 5 shows that I_p due to μE_s flows through R_p and Z_L in series, therefore

$$I_p = \frac{-\mu E_s}{R_p + Z_L} \quad \text{(This is the mathematical statement of the equivalent amplifier circuit).}$$

$$\text{Voltage Gain} = \frac{I_p Z_L}{E_s} = \frac{-\mu Z_L}{R_p + Z_L}$$

It should be noted that as Z_L approaches infinity, the gain approaches the μ of the tube as a limiting factor. This is a basic equation in which the voltages are measured at the grid and plate terminals of the tube. It does not take into consideration any voltage drop through a coupling condenser, resonant rise of voltage due to L and C in a load circuit, or the voltage step-up in transformer coupling.

RESISTANCE COUPLED VOLTAGE AMPLIFIER

The following analysis may be used with any type of tube. A thorough understanding of the principles outlined will enable one to select a proper tube for a particular purpose, and to properly proportion the circuit constants to obtain any desired frequency response. The advent of television with the very large range of modulation frequencies which must be handled makes the study of resistance coupling particularly important.

It should be understood that in the circuits where batteries are shown, the batteries may represent any source of D.C. potential.

A voltage amplifier should give the maximum voltage in the output circuit to be available for application to the grid of the next amplifier. This may be obtained by using a high resistance for Z_L (coupling resistance). The actual circuit as used in such an amplifier is shown in Figure 6.

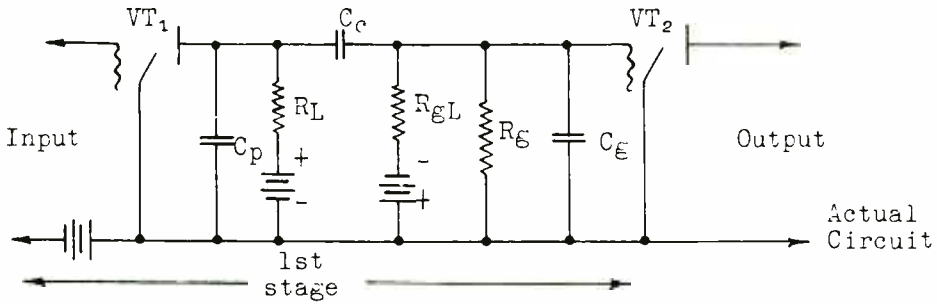

Fig. 6.

R_L is plate load resistance.

Z_L is load resistance across which amplified E is developed and consists of R_L and R_{gL} in parallel.

C_c is coupling capacity to prevent the plate voltage of VT_1 from being applied to the grid of VT_2 . C_c should be sufficiently large to offer low reactance to all frequencies that are to be amplified.

R_{gL} provides grid return for VT_2 and should be very high so that the shunting effect of R_{gL} and C_c across Z_L is small. E developed across Z_L is applied across R_{gL} through C_c .

C_p is the output capacity of VT_1 (filament-plate) + stray capacities.

C_g is the input capacity of VT_2 (filament-grid) + stray capacities.

R_g is the input resistance of VT_2 .

Figure 7 shows the exact equivalent to the circuit of Figure 6 while Figure 8 shows the practical equivalent circuit. By the analysis of a simplified equivalent circuit the expected results can be predicted to a high degree of accuracy.

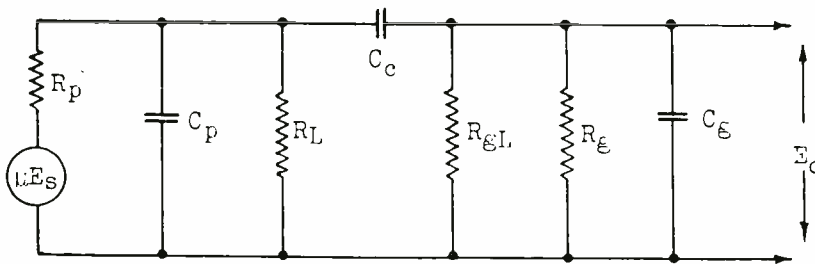

Exact Equivalent Circuit

Fig. 7.

C_p and C_g are combined as one capacity.
 R_g is neglected as it is usually very high and has very little shunting effect--so long as the grid is not allowed to swing positive.

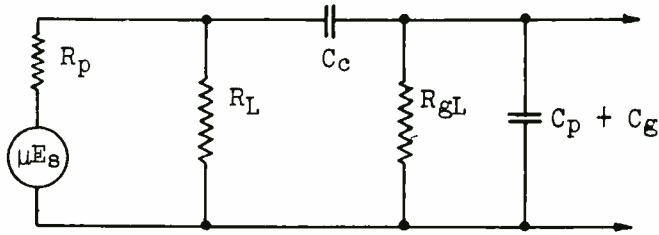

Practical Equivalent Circuit
 Fig. 8.

The important characteristic of the resistance coupled amplifier is the uniform gain obtained over a wide band of frequencies. A typical gain curve for such an amplifier is shown in Figure 9. The decrease in gain at the low frequencies is due to the high reactance of C_c at low frequency. The decrease at the high frequencies is due to the shunting effect of C_p and C_g across the input of VT_2 ; the capacity reactance of these condensers at the high frequencies is low, and reduces the voltage available for excitation of VT_2 .

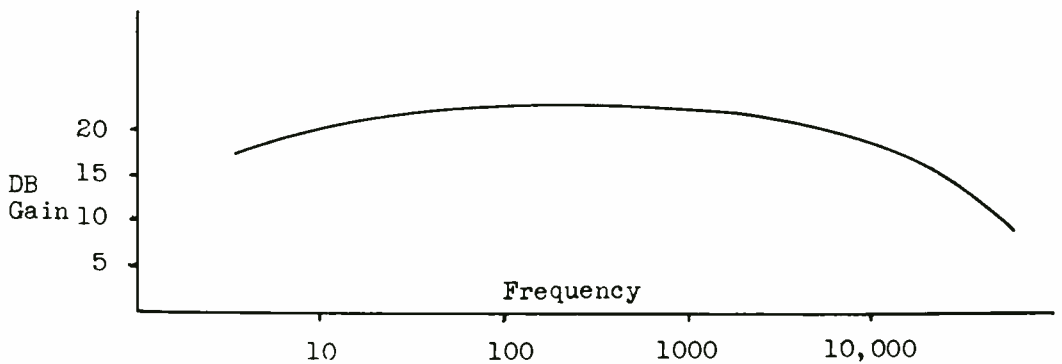

Fig. 9.

MAXIMUM AMPLIFICATION

The maximum amplification of a resistance coupled amplifier occurs at some intermediate frequency where the reactance of C_c is low with correspondingly low voltage drop across it, and where the

capacity reactance of the tube and stray capacities in parallel with Z_L are still high enough to have a negligible shunting effect. Under these conditions the equivalent circuit can be simplified as shown in Figure 10. C_c may be shorted out as its voltage drop may be neglected, C_p and C_g may be neglected as they have very little shunt effect at the intermediate frequencies.

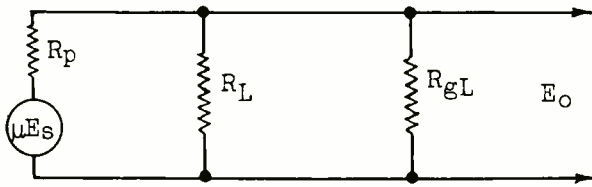

Fig. 10.

The amplification within the frequency range in which these assumptions are essentially true is calculated as follows:

$$\text{Maximum Gain} = \frac{E_o}{E_s} = \mu \frac{Z_L}{Z_L + R_p}$$

$$Z_L = \frac{R_L R_{gL}}{R_L + R_{gL}}$$

By substitution,

$$\frac{E_o}{E_s} = \mu \frac{1}{1 + R_p \frac{R_L + R_{gL}}{R_L R_{gL}}}$$

Output Voltage

$$E_o = -\mu E_s \frac{1}{1 + R_p \frac{R_L + R_{gL}}{R_L R_{gL}}}$$

The negative sign signifies that the stage of amplification reverses the phase and it can be disregarded for calculating the amount of gain. The phase reversal is important in television, and where two microphones pick up the same program and feed it through separate amplifiers to a common output; also when using microphones with head amplifiers. A phase reversing amplifier is sometimes required to correct a condition where the output of an amplifier is 180° out of phase with a signal voltage with which it must be combined.

Thus the maximum gain of the resistance coupled amplifier, which will occur at some intermediate frequency, is proportional to:

1. μ (Amplification factor) of the tube.
2. $\frac{Z_L}{Z_L + R_p}$ (in which Z_L represents the parallel combination of plate resistor and grid leak.)

The gain can never exceed the μ of the tube and is actually from 50 to 75 per cent of μ . The higher Z_L is made the greater the amplification, but the increase is small as Z_L is increased above R_p . Z_L is rarely made greater than 2 or 3 times R_p . If R_L is made extremely high the IR drop (D.C.) across it becomes excessive and distortion may be introduced due to the mismatch of tube and load impedances. Increasing R_{gI} increases the gain because this resistor is effectively in parallel with R_L , but if it is made too high the tube may block on strong signals and distortion may result. Figure 11 shows a typical gain curve for a resistance coupled amplifier plotted for varying values of Z_L/R_p .

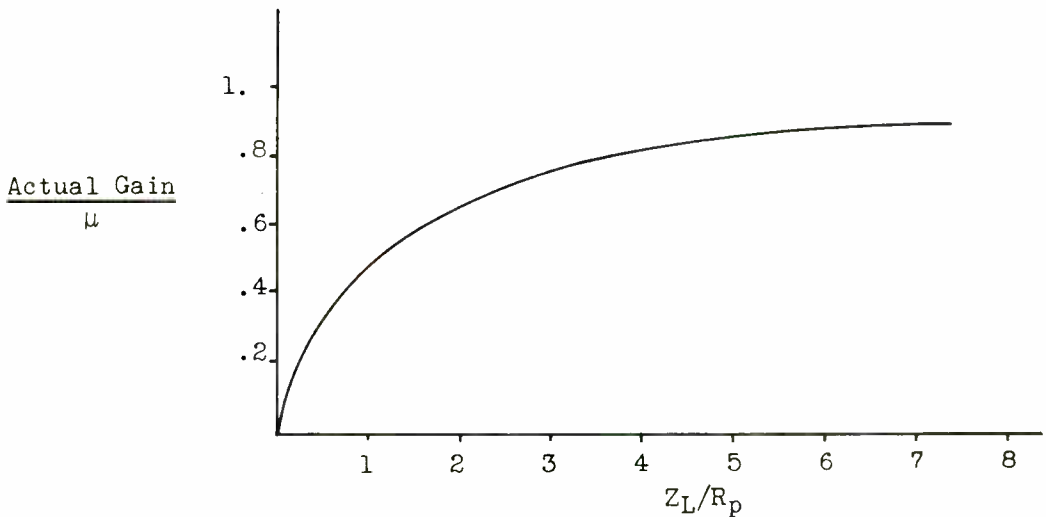

Fig. 11.

GAIN AT LOW FREQUENCIES

The gain of a resistance coupled amplifier at low frequencies can be predicted from the maximum gain as calculated above. Figure 12 shows the simplified equivalent circuit for low frequencies. C_g and C_p are negligible at low frequencies while C_c has appreciable reactance.

When $1/2\pi FC_c = R_{gI}$, $\frac{E_o}{E_s} = \frac{1}{\sqrt{2}}$ times Maximum Gain (as calculated for the intermediate frequencies). This is because the voltage appearing across R_{gI} , and hence being applied between the grid and

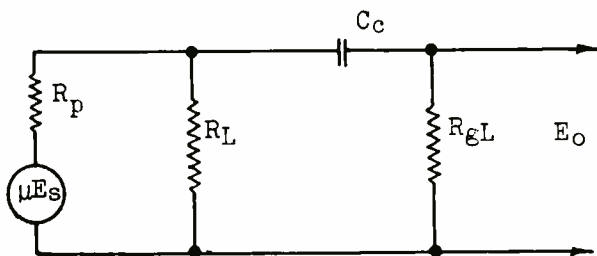

Fig. 12.

filament of the following tube, is 70 per cent of the voltage across R_L . The equivalent circuit and the vector expressing this condition are shown in Figure 13. Since the drop across R_{gL} is out of phase with the drop developed across Z_L , phase distortion is introduced

at low frequencies, but this is not serious as the time of the phase shift is small compared to the duration of the low frequency note.

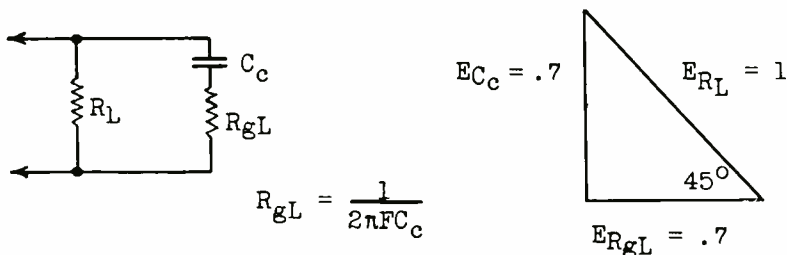

Fig. 13.

When $1/2\pi FC_c = 2R_{gL}$, that is, at one-half the frequency discussed in the preceding paragraph, the gain is approximately 45 per cent of maximum. As the frequency decreases X_{C_c} increases, thus decreasing the drop across R_{gL} with a corresponding decrease in gain.

$$\tan \theta = \frac{X_{C_c}}{R_{gL}} = \frac{2}{1} = 2.$$

$$\theta = 63^{\circ}26'$$

$$\cos 63^{\circ}26' = .447$$

Therefore, Gain = 44.7 per cent Maximum.

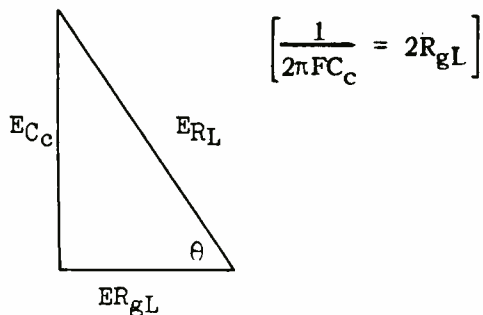

GAIN AT HIGH FREQUENCY

In calculating the gain at high frequencies the simplified equivalent circuit as shown in Figure 14 is used. At high frequencies the reactance of C_c can be neglected as it is very low. At high frequencies C_g and the stray capacities have appreciable shunting effect on Z_L which decreases the gain as the frequency is increased. In the simplified equivalent diagram C_g represents in parallel all shunting capacities which must be considered, Plate-Filament of VT_1 , Grid-Filament of VT_2 , Grid-Plate (Effective) of VT_2 , and the stray capacities of sockets and wiring, these stray capacities being estimated.

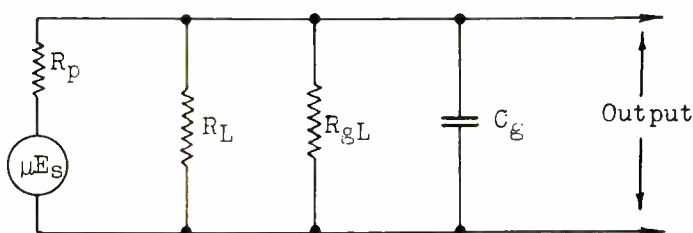

Fig. 14.

$$\frac{\text{Gain at High Frequencies}}{\text{Maximum Gain}} = \frac{1}{\sqrt{1 + \left[\frac{R}{X_C}\right]^2}}$$

R = equivalent resistance of R_L , R_p and R_{gL} in parallel.

$$X_C = \frac{1}{2\pi f C_g}$$

Thus to have the minimum reduction in gain at high frequencies it is essential that X_C be large, which means that C_g must be kept to a minimum.

From the capacity data given in the manufacturer's tube data C_g may be quite closely calculated.

$$C_g = C_s + C_{P-K}(VT_1) + C_{G-K}(VT_2) + C_{G-P}(VT_2) (1 + A).$$

C_s = Stray capacity of sockets and wiring which ordinarily must be estimated. An approximation of 20 $\mu\mu F$ will not be far in error in a typical case.

$$A = .7 \mu$$

K is Cathode.

For a Type 76 Triode:

$$\mu = 13.8$$

$$\text{Capacity P - K} = 2.5 \mu\mu\text{F}$$

$$\text{G - K} = 3.5 \mu\mu\text{F}$$

$$\text{G - P} = 2.8 \mu\mu\text{F}$$

Thus for a Type 76 Triode a sufficiently accurate calculation of C_g in $\mu\mu\text{F}$ will be,

$$C_g = 20 + 2.5 + 3.5 + 2.8(1 + 9.7) = 56 \mu\mu\text{F}.$$

EXAMPLE: Calculations for maximum, high frequency and low frequency gain for a typical stage of resistance coupled amplification will clearly demonstrate the practical use of the equivalent circuits and their equations. Assume the use of Type 6SF5 high- μ triodes. For this tube, $\mu = 100$, $R_p = 66,000$ ohms; tube capacities are as follows: G-P = $2.4 \mu\mu\text{F}$, G-K = $4 \mu\mu\text{F}$, P-K = $3.6 \mu\mu\text{F}$. Assume stray capacities of socket and wiring total $20 \mu\mu\text{F}$. Make $R_L = .25$ megohm, $R_{gL} = .5$ megohm, and $C_c = .01 \mu\text{F}$. The equivalent circuit is shown in Figure 15.

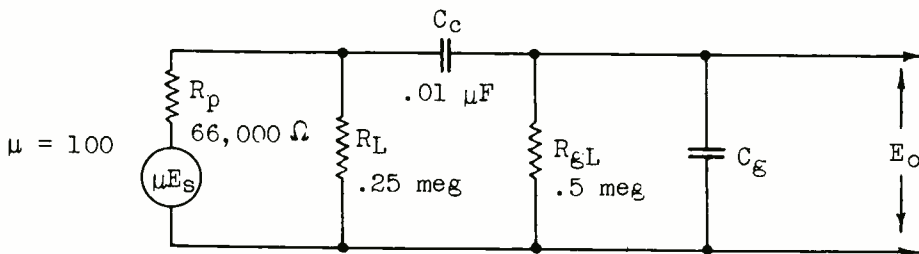

Fig. 15.

To find Maximum Gain at an intermediate frequency:

$$\begin{aligned} \frac{E_o}{E_s} &= \mu \frac{1}{1 + R_p \frac{R_L + R_{gL}}{R_L R_{gL}}} \\ &= \mu \frac{1}{1 + 66 \times 10^3 \frac{(.25 \times 10^6) + (.5 \times 10^6)}{(.25 \times 10^6 \times .5 \times 10^6)}} \\ &= \mu \frac{1}{1 + .396} = .7 \mu = .7 \times 100 = 70 \end{aligned}$$

The gain as calculated (70) per stage is the maximum gain that can be obtained at the best intermediate frequency *under the conditions specified*. This calculation neglects the drop across C_c at the low frequencies and the by-passing effects of C_g at the higher frequencies.

Gain at Low Frequencies: When $1/2\pi FC_c = R_{gL}$, Gain = .707 Maximum, Gain = .707 x 70 = 49.5.

At what frequency will gain equal .707 maximum gain?

$$R_{gL} = 5 \times 10^5 \text{ ohms.}$$

$$R_{gL} = 1/2\pi FC_c \text{ at the specified frequency.}$$

$$C = .01 \mu F = 10^{-8} \text{ Farad.}$$

$$\frac{1}{2\pi FC} = 5 \times 10^5 \text{ ohms}$$

$$F = \frac{1}{6.28 \times 10^{-8} \times 5 \times 10^5} = \frac{1}{31.4 \times 10^{-3}} = 32 \text{ cycles/second}$$

To find the gain at 50 cycles:

$$X_c = \frac{1}{2\pi FC_c} = \frac{1}{6.28 \times 50 \times 10^{-8}} = \frac{10^8}{314} = 318 \times 10^3$$

$$\tan \theta = X/R = \frac{318 \times 10^3}{5 \times 10^5} = .636$$

$$\theta = 32^\circ 28'$$

$$\cos 32^\circ 28' = .8437$$

$$\text{Gain at 50 cycles} = .8437 \text{ Max. Gain} = .8437 \times 70 = 59$$

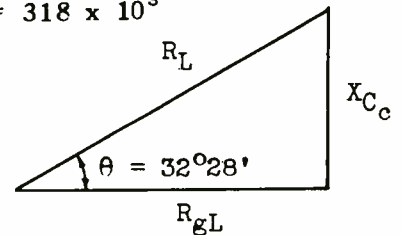

If C_c is increased to .1 μF the low frequency response will be considerably improved. The frequency at which Gain = .707 Maximum will be reduced to 3.1 cycles per second and at 50 cycles.

$$X_c = \frac{1}{2\pi FC_c} = \frac{10^7}{314} = 318 \times 10^2$$

$$\tan \theta = X/R = \frac{318 \times 10^2}{5 \times 10^5} = .0636$$

$$\theta = 3^\circ 38'$$

$$\cos 3^\circ 38'$$

$$\text{Gain at 50 cycles} = .998 \times 70 = 69.86 \text{ or practically } 70.$$

In other words, by increasing C_c from .01 μF to .1 μF , the maxi-

imum gain can be held constant down to 50 cycles/second instead of dropping off from 70 to 59 at that frequency. Thus to keep the low frequency response flat both C_c and R_{gL} should be reasonably large. Where for any reason it becomes necessary to use a low value of grid leak resistance, C_c must be increased in proportion to the decrease of R_{gL} if flat low frequency response is to be maintained.

By means of such simple calculations as those above the gain at a number of low frequency points may be determined and a response curve drawn.

To find the Gain at a High Frequency: As an example, calculate the gain of the amplifier of Figure 15 at 20,000 cycles/second.

$$\frac{\text{Gain at H.F.}}{\text{Maximum Gain}} = \frac{1}{\sqrt{1 + (R/X_{C_g})^2}}$$

R = Equivalent parallel resistance of R_p , R_L and R_{gL} .

$$R = \frac{1}{\frac{1}{66 \times 10^3} + \frac{1}{.25 \times 10^6} + \frac{1}{.5 \times 10^6}} = 47,200 \text{ ohms}$$

$$C_g = C_s + C_{P-K(VT_1)} + C_{G-K(VT_2)} + C_{G-P(VT_2)}(1 + A)$$

C_s has been approximated as 20 $\mu\mu\text{F}$. For the 6SF5, the tube capacities are: G-P = 2.4 $\mu\mu\text{F}$, G-K = 4 $\mu\mu\text{F}$, P-K = 3.6 $\mu\mu\text{F}$. $\mu = 100$.

$$C_g = 20 + 3.6 + 4 + 2.4(1 + 70) = 198 \mu\mu\text{F}$$

$$X_{C_g} = \frac{1}{6.28 \times 2 \times 10^4 \times 198 \times 10^{-12}} = 40,200 \text{ ohms}$$

$$(R/X_{C_g})^2 = \left[\frac{47,200}{40,200} \right]^2 = 1.37$$

$$\frac{\text{Gain at H.F.}}{\text{Maximum Gain}} = \frac{1}{\sqrt{1 + 1.37}} = .65$$

Therefore, gain at 20,000 cycles/second = .65 x 70 = 45.5.

Thus for this amplifier the following data may be tabulated:

Frequency	Gain
32 cycles/second	49.5
50 cycles/second	59.
Best intermediate frequency	70.
20,000 cycles/second	45.5

By calculating and plotting several additional low frequencies above 50 cycles, say 100 cycles and 200 cycles, and several high frequencies, say each 2000 cycles above 5000 cycles, a curve may be drawn to very accurately indicate the operation of this stage of resistance coupled amplification.

The effect of increasing C_g and R_p is to lower the high frequency gain. The amount of falling off in gain at the high frequencies depends on the value of C_g in relation to the equivalent parallel resistance of R_L , R_p and R_{gL} . In audio amplifiers it is customary to make R_L several times greater than R_p and to make R_{gL} still greater. Thus the equivalent parallel resistance is largely dependent upon R_p . For flat wide frequency response therefore a tube having low R_p , if the tube capacities are kept small, should be preferable. Such a tube will also normally have a lower value of μ which will tend to decrease the effective grid-plate capacity of VT_2 which will decrease C_g and hence bring up the high frequency response.

It should be noted in this connection that R_p is very largely dependent upon the negative bias at which the tube operates. Therefore the maximum gain and the shape of the high frequency response curve is to a great extent a function of the cathode resistor where self-bias is used.

Where a very wide flat high frequency response is much more important than high gain per stage, the plate coupling resistor R_L may be made quite small so that up to a very high frequency the reactance of C_g is large compared with R_L . Thus in television video amplifiers R_L as small as 1500 ohms or 2000 ohms is commonly used. While such amplifiers are compensated to bring up the response at both the very high and very low frequencies, flat high frequency response to 100,000 cycles/second or greater even without compensation is easily obtained. A high mutual-conductance pentode such as the 1852 will allow gain of about 18 per stage with R_L as low as 2000 ohms. The design of such amplifiers is discussed in the television section.

When a pentode is used as a resistance coupled amplifier the equation for maximum gain in the intermediate frequencies is based on the mutual conductance G_m rather than directly on R_p and μ . Thus for a pentode,

$$\text{Maximum Gain} = G_m R \quad \text{where } R \text{ equals } R_p, R_L \text{ and } R_{gL} \\ \text{in parallel.}$$

EXAMPLE: Consider an audio amplifier employing Type 6SJ7 pentodes. Make $R_L = .25$ megohm, $R_{gL} = .5$ megohm. R_p is greater than 1 megohm and $G_m = 1650 \mu\text{-mhos}$

$$R = \frac{1}{\frac{1}{.25} + \frac{1}{.5} + \frac{1}{1}} = .143 \text{ megohm}$$

$$\text{Gain} = G_m R = 1650 \times 10^{-6} \times .143 \times 10^6 = 236$$

Since the low and high frequency gains are a function of C_c and C_g respectively, just as in the case of a triode, the gain at the low and high frequencies will be calculated as a proportional part of the maximum gain just as for the triode.

If, with a 6SJ7, R_L is reduced to 2,000 ohms in order to permit very broad high frequency response, as for a video amplifier, R_L is so low that the large parallel components R_p and R_{gL} may be neglected. Then,

$$\text{Maximum Gain} = 1650 \times 10^{-6} \times 2000 = 3.3$$

It is apparent that if such low R_L is required for good proportionate high frequency response, it will be very desirable to employ a tube having large mutual conductance. One such tube developed for this purpose is the Type 6AC7 pentode having G_m of 9000. With that tube and R_L of 2000 ohms,

$$\text{Maximum Gain} = 9000 \times 10^{-6} \times 2000 = 18$$

The low frequency response is determined largely by the value of coupling capacity C_c . To avoid rapid falling off in gain at the lower frequencies the reactance of C_c must be low compared to R_{gL} . Where the amplifier is feeding a strong signal into a power tube whose grid leak must be kept relatively low to prevent blocking, R_{gL} may be as low as 50,000 ohms. It has been shown that with a $.01 \mu\text{F}$ condenser and R_{gL} of 500,000 ohms, the gain at 50 cycles is 84 per cent of maximum. If this is taken as the minimum gain desired at this frequency, and if a grid leak of 50,000 ohms is to be used, then C_c must have a capacity of $.1 \mu\text{F}$. If it is desired, with this same tube and grid leak, to keep the gain at 25 cycles up to 84 per cent of maximum, then the capacity of C_c should be $.2 \mu\text{F}$. It was shown that by using a grid leak of .5 megohm and increasing C_c from $.01 \mu\text{F}$ to $.1 \mu\text{F}$ the 50 cycle gain could be kept substantially at maximum instead of dropping to 84 per cent of maximum.

It would seem that the largest possible value of C_c should be used so that the fidelity curve on the low frequency end will be flat. This is true only within limits, however. If C_c is unduly large the time constant of the condenser and grid leak may be too great for the higher frequencies. Also the leakage of a larger condenser is greater, this leakage tending to place a positive bias on the grid of the following tube. Thus C_c should be the *minimum value that will give satisfactory low frequency response.*

Design of Resistance Coupled Amplifier:

1. Make a tentative selection of tubes. Use highest μ consistent with the high frequency response desired.
2. Estimate probable values of R_L and C_g . (R_L should be at least 2 to 3 times R_p except in the case of pentodes where it should be as high as practical.)
3. Select R_{gL} of 3 to 6 times R_L .
4. C_c should have the minimum value that will give the desired low frequency response with the value of R_{gL} selected.

From the above values make tentative calculations. From these calculations make the necessary changes in tubes or circuit constants to obtain the desired gain and frequency response.

The resistance coupled amplifier gives uniform gain over a wide band of frequencies and the cost is low. However the gain per stage is also low, (considerably less than the μ of the tube) and the performance may be unsatisfactory unless high grade C_c , R_L and R_{gL} are used.

MULTI-STAGE RESISTANCE COUPLED AMPLIFIER

In the design of such an amplifier there are several factors which must be considered.

1. Individual plate and bias batteries may be used but ordinarily a single B supply is provided for all stages.
2. The grid potential must be negative with respect to the filament at all times. Since the grid voltage is a function of both E_s and the bias, the bias of the first tube can be small because E_s is small. The bias of each succeeding tube must then be increased due to the increase in E_s . Either fixed bias cells or a self-biasing cathode resistor may be used.
3. Since E_p is usually supplied to all tubes from a common

source, care must be exercised to prevent interstage coupling. The plate current in Tube 2 varies in the opposite direction to the I_p variations in Tube 1 and Tube 3. Thus I_p variations in Tubes 1 and 3 are in the same direction.

Common plate currents through the voltage source tend to increase or decrease the excitation voltage of the various stages, depending on whether the currents are in phase or 180° out of phase. When in phase, regeneration results; when out of phase, degeneration occurs. The effects of regeneration due to common plate supply coupling can be reduced, especially at the high frequencies, by large bypass condensers between the battery side of R_L to cathode. At the very low frequencies it is not practical to use large enough condensers to prevent regeneration. In a three stage amplifier using a common plate supply, regeneration may build up to oscillation. This can be stopped by reducing C_c or R_{gL} . It is not practical to operate more than 4 stages of resistance coupled amplification from a common power supply and with wide band amplifiers such as television video amplifiers, two stages is often the limit.

The curves of Figure 16 are calculated for a high- μ triode having $\mu = 30$, $R_p = 125,000$ ohms. They are quite characteristic of all resistance coupled amplifiers. By means of simple calculations as already shown and with the characteristics of any tube it is desired to use taken from the manufacturer's tube manual, it is not difficult to determine the operating characteristics of any resistance coupled amplifier.

IMPEDANCE COUPLED AMPLIFIER

The actual circuit of the impedance coupled amplifier is shown in Figure 17. It will be seen that the only difference between this and the resistance coupled amplifier is in the substitution of inductance L in place of R as the load impedance R_L . The impedance coupled amplifier gives greater gain than does the resistance coupled amplifier but the range of uniform response is greatly reduced.

In Figure 19 the practical equivalent circuit of Figures 17 and 18, all shunt capacities are lumped as C_g . This value is calculated just as in the case of the resistance coupled circuit except there is the addition of C_L , the distributed capacity of L . C_c is neglected as the low frequency response is limited by the low value of X_L

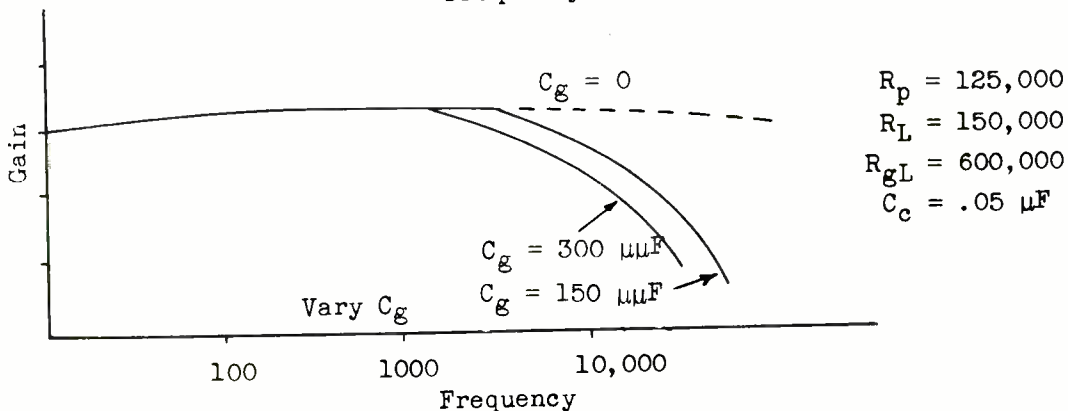
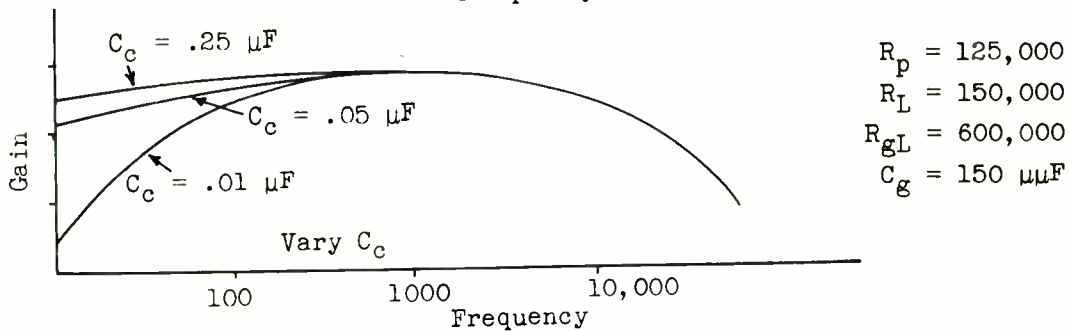
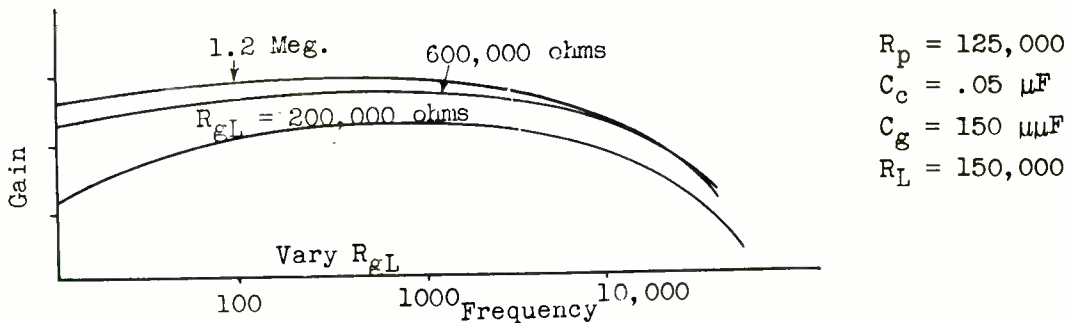
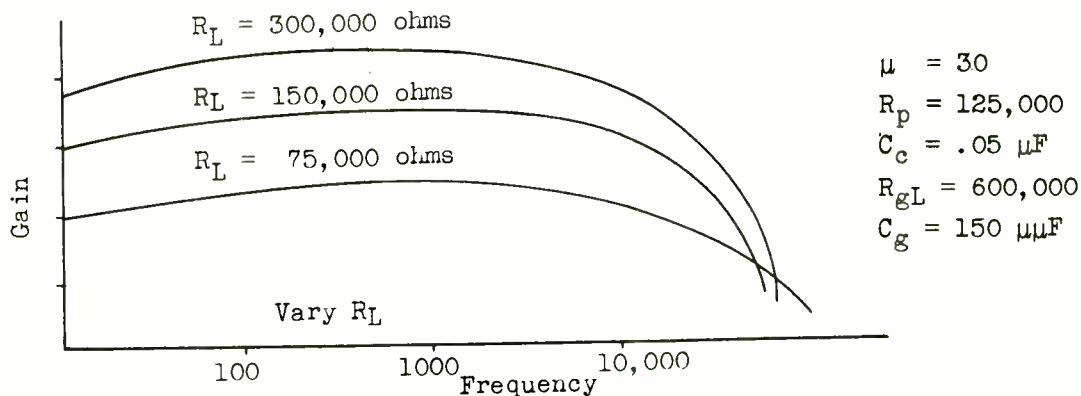

Fig. 16.

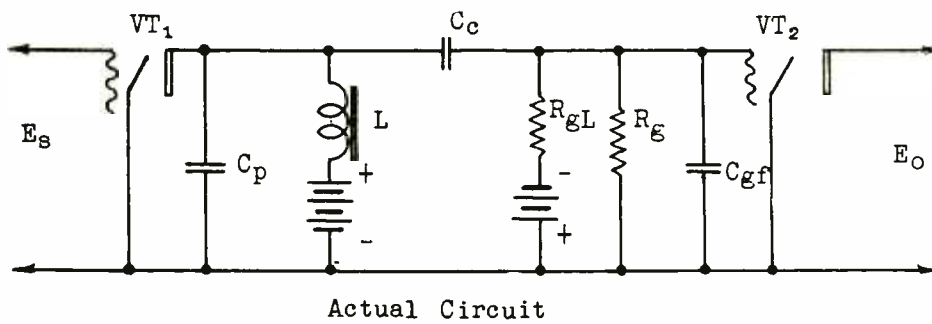
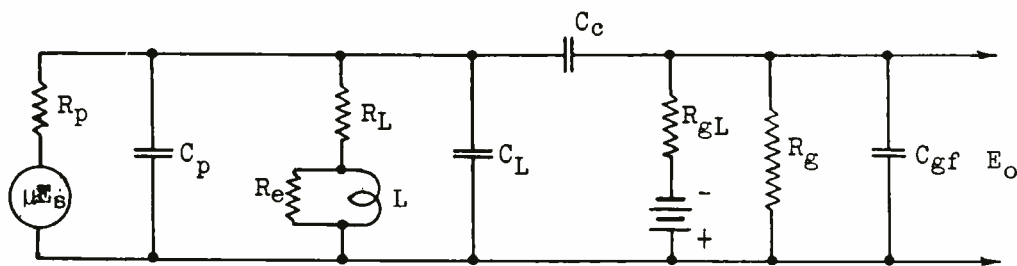

Fig. 17.



R_e represents core loss of L and is very high (1-5 meg). This introduces very little loss.

R_L represents ohmic resistance of L .

C_L represents the distributed capacity of L .

Fig. 18.

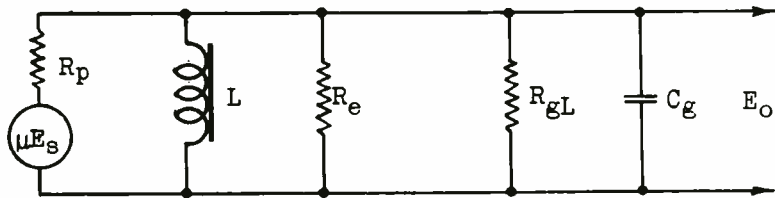

Fig. 19.

rather than by C_c . R_g and R_L are neglected. R_g is very high and has little shunting effect; R_L is very small compared to the reactance of L in series.

MAXIMUM AMPLIFICATION

The maximum gain occurs at some intermediate frequency in the region where L and C_g are in parallel resonance. At this point their resultant Z is very high with a correspondingly small shunting effect. Thus at the intermediate frequencies in the region of maximum gain, the practical equivalent circuit may be simplified as shown in Figure 20, by neglecting L and C_g .

$$\text{Maximum Gain} = \mu \frac{R}{R + R_p}$$

$$\text{where } R = \frac{R_e R_{gL}}{R_e + R_{gL}}$$

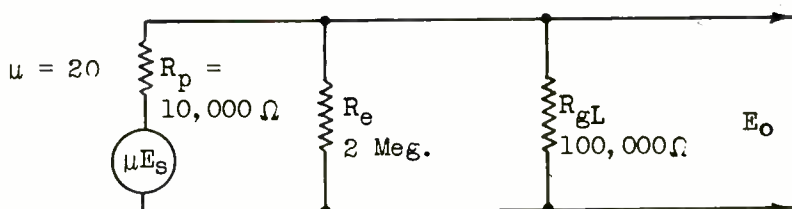

Fig. 20.

The maximum gain is always less than μ but approaches μ more closely than in the case of the resistance coupled amplifier.

EXAMPLE: Calculate the maximum gain when using a Type 6C5 tube. $\mu = 20$; $R_p = 10,000$ ohms; R_{gL} taken as $100,000$ ohms; R_e estimated at 2 megohms: (in practice R_e will be very high-- 1 to 5 megohms).

$$R = \frac{2 \times 10^6 \times 10^5}{(2 \times 10^6) + 10^5} = 9.5 \times 10^4 \text{ ohms}$$

$$\begin{aligned} \text{Maximum Gain} &= 20 \frac{9.5 \times 10^4}{(9.5 \times 10^4) + 10^4} \\ &= 20 \times .91 = 18.2 \end{aligned}$$

It will be seen that the maximum possible gain approaches μ very closely with this type of coupling. The use of a larger value of grid leak resistance would have resulted in still higher peak gain.

The maximum value of grid leak used with this tube should never exceed 1 megohm.

GAIN AT LOW FREQUENCIES

At low frequencies the reactance of L is low and therefore only a small voltage is developed across it. Thus the gain at low frequencies will be low. The equivalent circuit for low frequency analysis is shown in Figure 21. Assume the values of R_e and R_{gL} as before. Assume the inductance of L to be 50 henries.

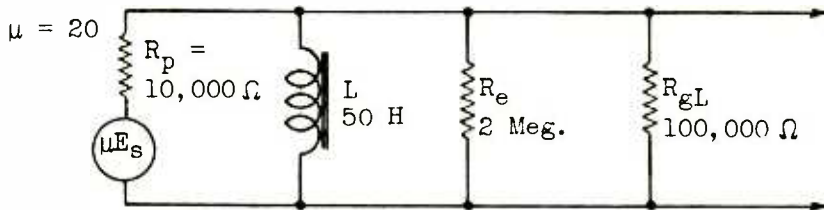

Fig. 21.

$$\begin{aligned} \frac{\text{Low Frequency Gain}}{\text{Maximum Gain}} &= \frac{1}{\sqrt{1 + \left(\frac{R_p, R_{gL} \text{ and } R_e \text{ in parallel}}{\omega L} \right)^2}} \\ &= \frac{1}{\sqrt{1 + \frac{1}{\omega L \left(\frac{1}{R_p} + \frac{1}{R_{gL}} + \frac{1}{R_e} \right)}}} \end{aligned}$$

To find the gain at 30 cycles:

$$\begin{aligned} \frac{\text{Low Frequency Gain}}{\text{Maximum Gain}} &= \frac{1}{\sqrt{1 + \left[\frac{1}{9420 \left(\frac{1}{10,000} + \frac{1}{10^6} + \frac{1}{2 \times 10^6} \right)} \right]^2}} \\ \omega L &= 6.28 \times 30 \times 50 = 9420 \\ &= \frac{1}{\sqrt{1 + (.96)^2}} = \frac{1}{\sqrt{1.92}} = .72 \end{aligned}$$

$$\text{Gain} = .72 \text{ Max. Gain} = .72 \times 18.2 = 13.1$$

It will be remembered that the calculations for the resistance coupled amplifier previously discussed, using a tube having μ of 100,

showed a maximum gain of $.7 \mu$ with gain at 31 cycles equal to 49.5. With the impedance coupled amplifier above the maximum gain is greater ($.9 \mu$) and the gain at 30 cycles is 13.1, a somewhat similar percentage decrease.

It particularly should be noted however, that in the case of the previously discussed resistance coupled amplifier a tube having $R_p = 66,000$ ohms was used. In the impedance coupled amplifier above the Type 6C5 tube has R_p of only 10,000 ohms and thus even at a frequency as low as 30 cycles, the reactance of the 50 henry reactor approximates R_p . Had a high R_p tube been used in the impedance coupled amplifier with the same 50 henry reactor, or had a smaller value of L been used, the gain at 30 cycles would have been much lower. This can easily be proved by working out the above problem, changing only the value of R_p and possibly increasing the value of the grid leak. If a tube is used having R_p of 125,000 ohms and μ of 30, and if R_{gL} is increased to 400,000 ohms, everything else being unchanged, the maximum gain will become 21.9--about 20 per cent higher than calculated for the 6C5--but the 30 cycle gain will be 2.3--only about 17 per cent as high as the 30 cycle gain when using the 6C5. Thus there is little advantage of using a high μ -high R_p tube with impedance coupling even to obtain high peak gain, and there is every disadvantage when frequency response is considered.

Where in the case of the high μ tube 30 cycle gain is only 17 per cent of maximum gain, with the 6C5 tube operated as shown, 30 cycle gain is 72 per cent of maximum gain and the amplifier will have a very good low frequency response.

An examination of the equation of Gain Ratio as shown above indicates that, since R_p is the smallest parallel resistor therefore controlling R , the gain ratio depends largely upon the ratio $R_p/\omega L$. So long as the ratio $R_p/\omega L$ is large, the gain will be small. Large gain can be obtained only by the use of large ωL or small R_p . Since with a high R_p tube an inductance of 50 henries gives such poor results, it is apparent that no reasonable size of L will produce good low frequency gain with such a tube. Therefore since it is not practical to indefinitely increase the value of L , to get good low frequency response it will be necessary to reduce R_p . This will require the use of a comparatively low μ tube because the really high μ tubes all have large R_p .

By using a low μ tube the gain at 30 cycles, instead of being negligible, becomes 73 per cent of the maximum gain and the low frequency response will compare favorably, in quality, with that of the resistance coupled amplifier.

GAIN AT HIGH FREQUENCIES

At the high frequencies the reactance of L is so great that its shunting effect may be considered negligible. C_c may be considered as short-circuited because its reactance becomes negligible. The conditions are thus similar to resistance coupling at the same high frequencies. Figure 23 shows the practical equivalent circuit while Figure 22 shows the actual circuit. It will be observed that C_g is now a factor.

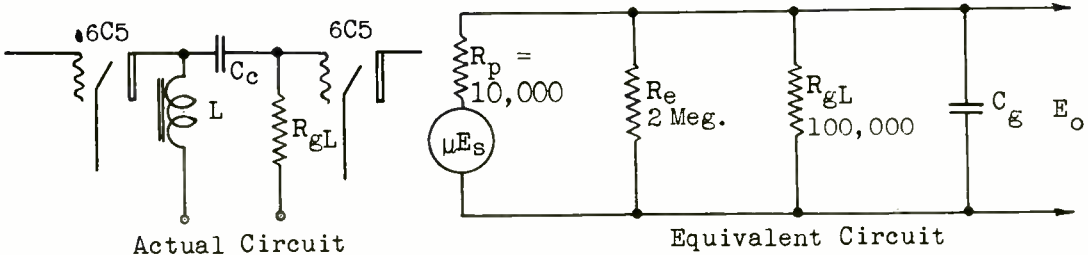

Fig. 22.

Fig. 23.

$$C_g = C_{\text{stray}} + C_{P-K(VT_1)} + C_{G-K(VT_2)} + C_{G-P(VT_2)} (1 + .7 \mu)$$

C_{stray} includes capacity of sockets and wiring and the distributed capacity of L which may be quite a large factor.

The interelement tube capacities for the 6C5 tube are as follows: $C_{P-K} = 11 \mu\mu\text{F}$, $C_{G-K} = 3 \mu\mu\text{F}$, $C_{G-P} = 2 \mu\mu\text{F}$. Assume that the distributed capacity of L is $46 \mu\mu\text{F}$ and that the stray capacity of socket and wiring is $20 \mu\mu\text{F}$.

Then,

$$C_g = 66 + 11 + 3 + 2(1 + .7 \mu)$$

$$C_g = 66 + 11 + 3 + 30 = 110 \mu\mu\text{F} = 11 \times 10^{-11} \text{ Farad}$$

$$\frac{\text{High Frequency Gain}}{\text{Maximum Gain}} = \frac{1}{\sqrt{1 + \frac{R_p, R_{gL} \text{ and } R_e \text{ in parallel}^2}{\frac{1}{\omega C_g}}}}$$

To find Gain at 10,000 cycles:

$$R_{\text{parallel}} = \frac{1}{\frac{1}{R_p} + \frac{1}{R_{gL}} + \frac{1}{R_e}} = \frac{1}{\frac{1}{10^4} + \frac{1}{10^5} + \frac{1}{2 \times 10^6}}$$

$$= 9050 \text{ ohms.}$$

$$X_{C_g} = \frac{1}{\omega C_g} = \frac{1}{6.28 \times 10^4 \times 11 \times 10^{-11}} = \frac{10^9}{6900} = 145,000 \text{ ohms.}$$

$$\frac{9050}{145,000} = .0624$$

$$\frac{\text{Gain at 10,000 Cycles}}{\text{Maximum Gain}} = \frac{1}{\sqrt{1 + .0624^2}} = \frac{1}{\sqrt{1.004}} = .998$$

$$\text{Gain} = .998 \text{ Maximum Gain} = .998 \times 18.2 = 18.16$$

To those familiar with audio frequency amplifiers and the difficulty of obtaining uniform gain over a wide range of frequencies, the above amplification characteristics may seem surprisingly good. However it must be understood that every factor was carefully chosen to obtain such frequency response. First, and very important, a tube having low R_p was used. Supposing a Type 6F5 (high μ triode) had been used because of its greater amplification factor, 100 as compared with 20 for the 6C5. The first difficulty would have been in obtaining good gain at the low frequencies. R_p for the 6F5 is 66,000 ohms. At all frequencies below about 220 cycles, the reactance of L would be *less than* R_p so that the low frequency gain with even a 50 henry reactance would fall off sharply below 220 cycles.

If it is attempted to use a reactor much larger than 50 henries --and it would have to be *much* larger to accomplish any real results in this case, the capacity of the winding would tend to be excessive and lower the high frequency response.

Second, in the case of the 6F5 the grid-plate capacity is greater--2.3 as compared with 2 for the 6C5--and in the calculation for C_g , this must be multiplied by $(1 + .7 \mu)$ so that with the 6F5 the effective input capacity of the second tube becomes $2.3(1 + .7 \mu) = 2.3(1 + 70) = 163 \mu\mu\text{F}$ as compared with $30 \mu\mu\text{F}$ for the 6C5. An examination of the equation for the high frequency gain ratio will show the effect this would have on the high frequency gain. C_g is largely

the limiting factor for high frequency gain.

Thus while the maximum possible gain would be greater with a 6F5 than with a 6C5, the frequency range of essentially uniform gain would be greatly reduced. This principle is always applicable in the selection of tube types. For flat gain over a wide band of frequencies with impedance coupling, the following principles must be followed:

1. R_p must be comparatively small in order that excessive I is not required. This means that comparatively low μ tubes must be used.

2. For good high frequency gain C_g must be kept to a minimum. This means that the interelement tube capacities must be small and that μ must not be too great. L must have a small distributed capacity. The socket construction and wiring must be such that their capacity is reduced to a minimum.

3. L must be as large as possible consistent with reasonable distributed capacity. The distributed capacity of L will usually be between 20 $\mu\mu\text{F}$ and 100 $\mu\mu\text{F}$, depending upon the type of winding used.

DESIGN OF IMPEDANCE COUPLED AMPLIFIER

1. The inductance L must be carefully designed with proper air gap to prevent saturation. It must be wound to have minimum distributed capacity. The laminations should be very thin to minimize core loss. A high permeability core should be used to allow maximum L with minimum turns.

2. The low frequency gain depends largely on the ratio of X_L/R so that for a given L , a low R_p tube gives better low frequency response. X_L is usually made not greater than $2R_p$ at the lowest desired frequency as little additional gain is obtained when X_L exceeds that value.

3. Use L of the largest value practical (avoiding excessive distributed capacity) and tubes of the highest μ that will give required low frequency gain. Low μ tubes also improve the high frequency response.

4. R_{gI} should be 5 to 15 times R_p to obtain maximum gain. If R_{gI} is made too high the tube will be blocked.

5. C_c should be of such value that the frequency at which $X_{C_c} =$

R_{g1} is lower than the frequency at which $X_L = R_p$. This will assure the low frequency gain is not limited by C_c .

ADVANTAGES AND DISADVANTAGES

1. The maximum gain is somewhat more than with resistance coupling.

2. A much lower plate voltage supply is required because the IR drop through L is negligible as compared with the IR drop through a resistance used as R_L .

3. The low frequency gain ratio is not as good as with resistance coupling.

4. The high frequency gain ratio is not as good as with resistance coupling unless the amplifier is peaked or tuned to a higher frequency, in which case it tends to become unstable.

It will be noted that the disadvantages somewhat outweigh the advantages of impedance coupling. Therefore, impedance coupling at audio frequency is not widely used. Where uniform gain over a wide band of frequencies is required, resistance coupling ordinarily is used. Transformer coupling is used where higher gain is required.

TRANSFORMER COUPLED AMPLIFIER

The transformer coupled audio frequency amplifier is more commonly used than either the resistance or impedance coupled amplifier. This is due to the fact that the gain is not limited to less than the μ of the tube as with resistance and impedance coupling, but instead may greatly exceed the μ of the tube.

The load impedance Z_L is the primary of the transformer, the secondary voltage of which is used to excite the following tube. This is shown in Figure 24. No coupling condenser or grid leak is required.

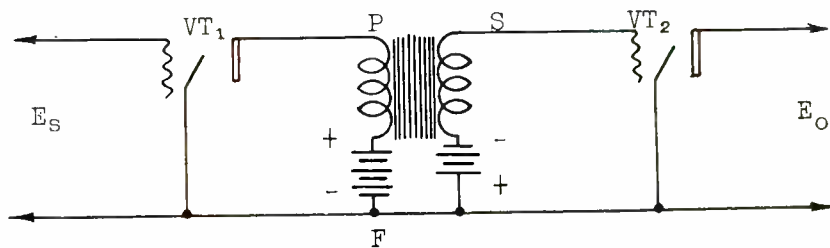

Fig. 24.

The principal advantage of transformer coupling lies in the fact that a step-up turns ratio may be used to multiply the output voltage of VT_1 before applying it as excitation to the grid of VT_2 . Thus with a step-up ratio of 3 to 1, the voltage applied to the grid of VT_2 is approximately 3 times the output voltage of VT_1 . The step-up factor along with other factors which include the coefficient of coupling, the distributed capacity of the windings, the leakage reactance, and the capacity between primary and secondary windings, make the calculation for gain of a transformer coupled amplifier more complex than that of the amplifiers previously discussed.

There are several methods used for analyzing the operation of transformer coupled amplifiers. Most methods require different procedures at the low, intermediate, and high frequencies. The method described below was developed by one of the largest laboratories for predicting the operation of amplifiers and may be used with reasonable accuracy (within 10 per cent) over the entire band of audio frequencies. It is thus preferable to those methods involving different procedures at different frequencies.

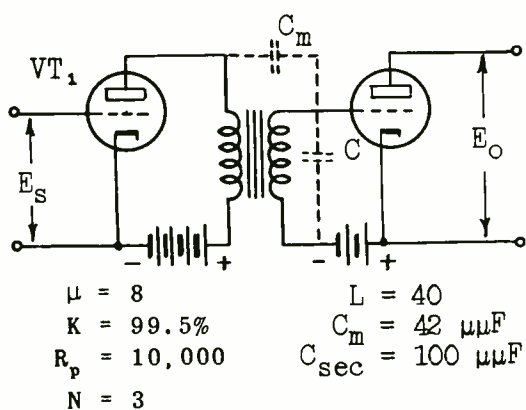

Fig. 25.

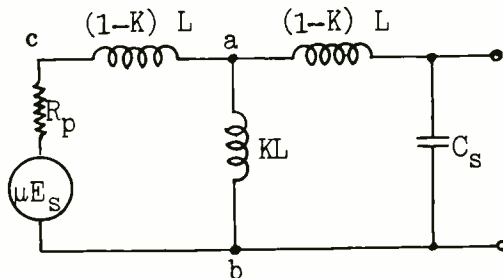

Fig. 26

Figure 25 shows the stage of amplification with the factors necessary in the calculation. The figures given for the transformer constants are actual values for a high grade transformer of a leading manufacturer. Figure 26 shows the practical equivalent circuit as used for purposes of analysis.

The general equation for the equivalent circuit of the transformer coupled amplifier is quite complex but the process of computing the gain at any given frequency may be simplified by using the following procedure:

Let:	$X_1 = 2\pi FKL$	Where:	F = Frequency, cycles/sec.
	$X_L = 2\pi F(1 - K)L$		K = Transformer coefficient of coupling, ordinarily 98 per cent or greater for a good transformer.
	$C_s = N^2 C_{sec} + (N \pm 1)^2 C_m$		L = Inductance of primary winding in Henries.
	$X_C = \frac{1}{2\pi F C_s}$		N = Transformer Turns Ratio.
	$X_2 = X_L + X_C$		C_{sec} = Distributed capacity of secondary winding.
	$X_{ab} = \frac{X_1 X_2}{X_1 + X_2}$		C_m = Capacity between primary and secondary windings.
	$X_{cb} = X_L + X_{ab}$		R_p = Tube Dynamic Plate Resistance.
	$Z = \sqrt{R_p^2 + X_{cb}^2}$		μ = Tube Amplification Factor.
Then: Gain =	$\mu N \frac{X_{ab} X_c}{Z X_2}$		

In the equation for C_s , the choice of sign, + or -, in the factor $(N \pm 1)$ is determined by the connection of the secondary. With normal connection the sign is +. If the connections of grid and filament are reversed, the sign will be -. The normal connection is such that the outside terminals of the windings connect respectively to plate and grid.

Example: To find the gain of a stage of transformer coupled amplification (See Fig. 25) using a tube having $\mu = 8$, and $R_p = 10,000$ ohms. The transformer primary inductance is 40 Henries, measured with the normal DC component of current flowing through the winding. The transformer step-up ratio is 3, and its coupling coefficient is 99.5 per cent. The secondary distributed capacity is 100 $\mu\mu F$, and the capacity between windings is 42 $\mu\mu F$.

Assume the gain is to be calculated for a frequency of 25 cycles per second. The Equivalent Primary Reactance X_1 offered by the primary at this frequency will be:

$$X_1 = 2\pi FKL = 6.28 \times 25 \times .995 \times 40 = 6250 \text{ ohms.}$$

With a coefficient of coupling of 99.5 per cent, the Leakage Reactance, X_L , will amount to:

$$X_L = 2\pi f(1 - K)L = 6.28 \times 25 \times (1 - .995) \times 40 = 31.4 \text{ ohms.}$$

The Shunt Capacity Reactance, X_C , is a function of the frequency and of the total Effective Shunt Capacity, C_s , as follows:

$$\begin{aligned} C_s &= N^2 C_{\text{sec}} + (N + 1)^2 C_m = 3^2 \times 100 + 4^2 \times 42 \\ &= 900 + 672 = 1572 \text{ } \mu\mu\text{F.} = 1.57 \times 10^{-9} \text{ Farad} \end{aligned}$$

$$X_C = - \frac{1}{2\pi f C_s} = - \frac{10^9}{6.28 \times 25 \times 1.57} = -4050000 \text{ ohms.}$$

Note that the values of X_1 and X_L are always positive, indicating inductive reactance, while X_C is always negative showing that this reactance is capacitive. Due respect must be paid to these signs in performing the remaining steps of the procedure:

$$X_2 = X_L + X_C = 31 - 4050000 = -4050000 \text{ ohms, practically.}$$

$$X_{ab} = \frac{X_1 X_2}{X_1 + X_2} = \frac{6250(-4050000)}{6250 - 4050000} = +6250 \text{ ohms, practically.}$$

$$X_{cb} = X_L + X_{ab} = 31 + 6250 = 6281 \text{ ohms.}$$

It may be observed at this point that with a well designed low ratio transformer at the low audio frequency of 25 cycles the leakage reactance will be so small and the shunt capacity reactance will be so great that neither will exert appreciable effect upon the value of X_{cb} , which therefore closely approximates the value of X_1 . Continuing the procedure:

$$Z = \sqrt{R_p^2 + X_{cb}^2} = \sqrt{10000^2 + 6281^2} = 11800 \text{ ohms.}$$

$$\text{Gain} = \mu N \frac{X_{ab} X_c}{Z X_2} = \frac{8 \times 3 \times 6250 \times (-4050000)}{11800 \times (-4050000)} = 12.7$$

$$\text{Gain, DB} = 20 \log 12.7 = 20 \times 1.1038 = 22 \text{ DB}$$

The gain may be similarly calculated for a large number of frequencies selected at intervals over the audio spectrum, and a curve drawn on semi-logarithmic paper to show the variation of gain with frequency. See the table on Page 33 and Figure 27.

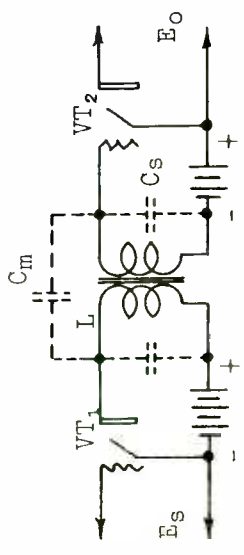
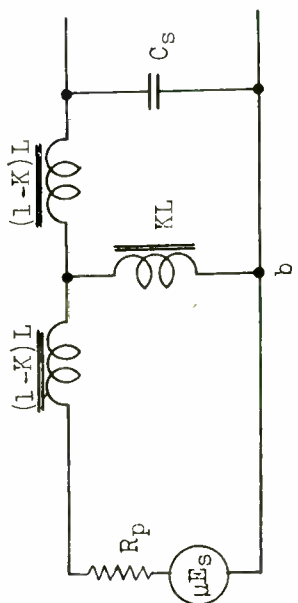

F	X_1	$(\text{Leakage } X) / 2\pi F(1-K)L$	X_c	X_2	X_{ab}	X_{cb}	Z	$X_c X_{ab} / Z X_2$	Voltage Gain	Gain db
25	+ 6250	+ 31	-4050000	-4050000	+ 6250	+ 6281	11800	.53	12.7	22
50	12500	63	2025000	2025000	12600	12630	16120	.78	18.7	25.4
100	25000	126	1012000	1012000	24400	24500	26500	.921	22.1	26.9
200	50000	251	506000	506000	55400	55700	56600	.98	23.5	27.4
400	100000	502	253000	252000	165600	166000	166000	.997	23.9	27.6
800	200000	1005	127000	126000	-341000	-340000	340000	1.01	24.1	27.6
1600	400000	2010	63300	61000	72400	70400	71000	1.038	24.9	27.9
3200	800000	4021	31600	28000	28600	24500	26500	1.23	29.7	29.4
6400	1600000	8042	15800	8000	7800	+ 227	10000	1.6	38.0	31.6
9600	2400000	12060	10500	+ 1500	+ 1530	13600	16900	.625	16.2	24.2
12800	3200000	16080	7900	8000	8200	24000	26000	.302	7.4	17.4

It will be observed at 25 cycles the voltage gain is approximately $\mu N/2$. From 100 cycles to 1600 cycles the response is practically uniform, being approximately μN . Beyond 1600 cycles the gain curve rises until at 6400 cycles the gain is more than 50 per cent greater than μN . At 7600 cycles the gain has fallen to approximately $.66 \mu N$ and at 12,800 cycles the gain is only $.3 \mu N$.

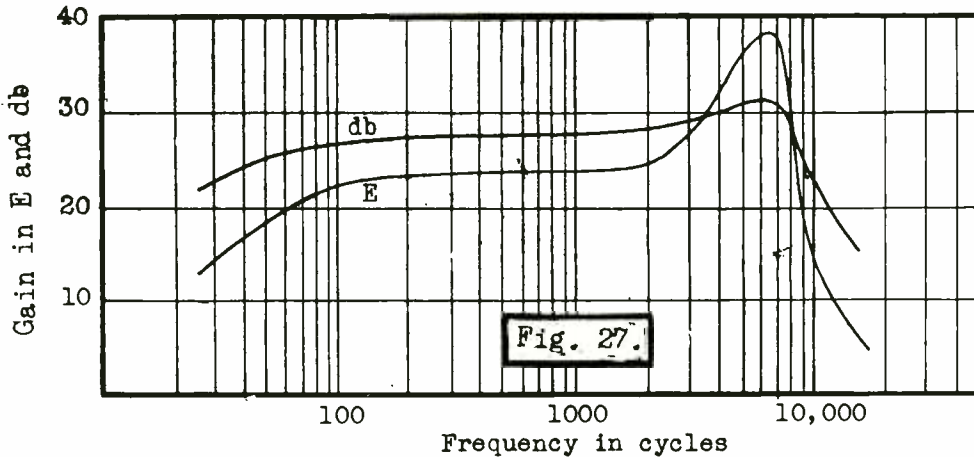

Figure 27 shows the gain curve for this stage of amplification.

It will be observed that the low frequency gain is quite good down to below 50 cycles. The rapid rise above 3000 cycles is accentuated by the fact that a logarithmic scale of frequency is used. The gain is excellent to about 10,000 cycles with a rapid cut-off beyond that point. Since 10,000 cycles is usually considered adequate for high fidelity reproduction (extensive tests have demonstrated that little improvement is noted by the average person when frequencies much above 8000 cycles are reproduced) this cut-off is entirely satisfactory for most audio work. It should be noted however that even at 10,000 cycles the gain is quite good, being 23.8 db at 9600 cycles.

As a rule at least two stages of amplification are used. By combining the above amplifier stage with one for which the gain curve falls off above 3000 cycles, the combined gain of the amplifier can be made essentially flat through the higher frequencies. The logarithmic curve of gain in decibels plotted in dotted line on Figure 27 indicates that the response, so far as can be noted by the human ear, is very good from about 30 to 10,000 cycles. From 50 to 6400

cycles the maximum total variation is 6.2 db. The variation around the optimum value of 27.6 db is still less, being +4 at 6400 cycles, -2.2 db at 50 cycles, and -3.4 db at 9,600 cycles.

The intermediate frequency gain approximates μN over the range where the inductance of the primary and C_s are approximately in parallel resonance. In this case,

$$C_s = (N^2 C_{sec}) + (N + 1)^2 C_m$$

$$C_s = (3^2 \times 10^{-10}) + (4^2 \times 42 \times 10^{-12})$$

$$C_s = (9 \times 10^{-10}) + (672 \times 10^{-12}) = 1572 \times 10^{-12} \text{ Farad.}$$

$$L = 40 \text{ H.}$$

$$F(\text{Parallel Resonance}) = \frac{1}{6.28 \sqrt{40 \times 1572 \times 10^{-12}}} = 635 \text{ cycles}$$

The high frequency limit of gain without undue frequency discrimination approximates the frequency at which the leakage inductance $(1-K)L$ is in series resonance with C_s . In this case,

$$\text{Leakage } L = (1 - .995)40 = .2 \text{ Henry.}$$

$$C_s = 1572 \times 10^{-12} \text{ Farad.}$$

$$F(\text{Series resonance}) = \frac{1}{6.28 \sqrt{.2 \times 1572 \times 10^{-12}}} = 9000 \text{ cycles.}$$

Increasing the leakage reactance or the shunt capacity reduces the peak frequency. It will be noted in Figure 27 that the gain falls off very rapidly above 9000 or 10,000 cycles so that considerable distortion would be introduced if it were attempted to amplify frequencies higher than 10,000 cycles.

LOW FREQUENCY GAIN

At low frequencies the gain falls off due to the low value of X_L compared to R_p . Therefore low R_p tubes must be used to avoid low frequency discrimination. To increase X_L requires more turns on the primary. This necessitates a larger transformer and the use of a lower turns ratio to prevent excessive distributed capacity across

the secondary winding. At the low frequencies, X_C of the secondary winding is very high and its shunting effect may be neglected. However if a high ratio transformer is designed to have a large primary inductance, the excessive secondary capacity, while having negligible effect at the lower frequencies, will greatly decrease the high frequency range of undistorted amplification. It is for this reason that in a radio receiver employing a high R_p detector tube, the first audio transformer should be one having a large primary inductance and a low turns ratio.

INTERMEDIATE FREQUENCY GAIN

At the intermediate frequencies centering around the parallel resonance point of $X_L = X_C$, the gain is fairly uniform and approximates μN . Parallel resonance is usually obtained around 500 - 1500 cycles and within this range the impedance of the circuit is high. X_L is high compared to R_p and the signal drop across R_p is small.

HIGH FREQUENCY GAIN

At high frequencies X_L is very high and has very little shunting effect. Since it is much higher than R_p it ceases to be the limiting factor of gain.

At high frequencies the leakage reactance $[2\pi F(1 - K)L]$ and X_{C_s} are the important factors in determining gain. These reactances form a series resonant circuit as shown in Figure 28. R_s represents

the equivalent transformer secondary resistance. The form of the gain curve at high frequencies depends on the Q value of the equivalent circuit. $Q = X_L/R$. In this case,

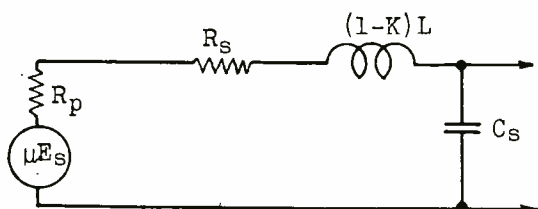

Fig. 28

$$R_s = \frac{R_{sec}}{N^2}$$

$$Q = \frac{X_L}{R} = \frac{2\pi F(1-K)L}{R_p + R_s}$$

When Q approximates unity the gain at high frequencies is fairly constant. When the frequency passes through series resonance the

gain may rise or fall and then drop off very rapidly. If $R_p + R_s$ is large compared to the leakage reactance, the gain drops off at the high frequencies without first rising to a peak. If the leakage reactance is large compared to $R_p + R_s$, the gain may rise to a high value around the point where the leakage reactance and C_s are in series resonance. Under such conditions Q is greater than 1. Figure 29 illustrates the high and low values of Q .

It will be seen that increasing the leakage reactance, other factors such as R_p , C_s and L remaining unchanged, increases the high frequency distortion. With given primary inductance, the leakage reactance at a given frequency is inversely proportional to K ; $X_L = 2\pi F (1-K)L$. Thus a large value of K represents a small leakage inductance. With high grade audio transformers K , the coefficient of coupling, should be from 98 to well over 99 per cent. However transformers having K values as low as 90 per cent are used.

A large leakage inductance combined with a given value of C_s also decreases the series resonance frequency and thus decreases the high frequency range of reproduction. The high frequency distortion due to excessive Q may be compensated for by the use of a higher μ tube with the corresponding increase in R_p . However this will increase the low frequency distortion. It is apparent that good design for high fidelity reproduction over a wide band of frequencies requires the use of low R_p tubes and transformers with comparatively

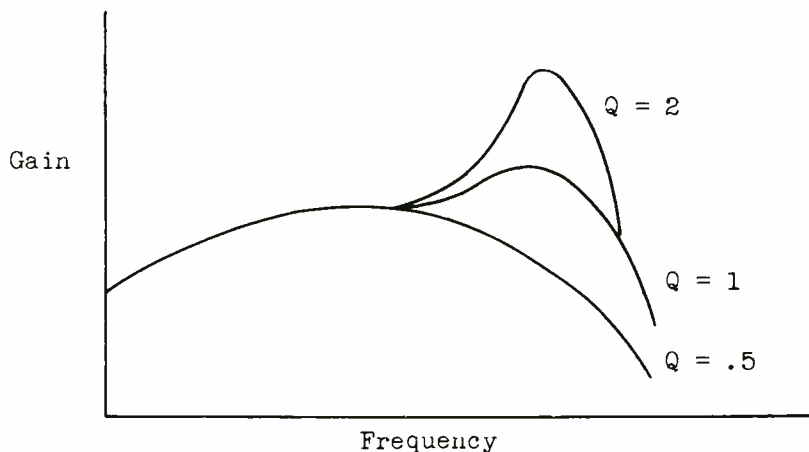

Fig. 29

low turns ratio N , large primary inductance L , and high coefficient of coupling K .

It particularly should be noted that C_s , which with the leakage reactance determines the high frequency limit of gain, is a function of N^2 .

$$C_s = (N^2 C_{sec}) + (N + 1)^2 C_m$$

Therefore, while increasing the number of secondary turns increases both C_{sec} and C_m , it also increases N^2 , so that from every viewpoint, while a large step-up factor increases μN , it also decreases the frequency range of undistorted amplification. Where high fidelity amplification is required, it is much better to use more stages of amplification and less gain per stage.

Amplifier frequency requirements are as follows:

Speech, 300 - 2800 cycles.

High quality music, 30 - 8000 cycles.

Increasing the high frequency range to 16000 cycles gives distinct improvement for some sounds, such as keys jingling.

It should be noted that in the analysis of the transformer coupled amplifier the question of plate and grid currents has not been considered. It is assumed that the primary inductance as specified is the inductance effective to the audio frequency component of plate current when normal D.C. plate current is flowing through the winding. It is also assumed that the following tube is operated as a Class A amplifier, that is, properly biased with excitation voltage not allowed to exceed the amplitude that will drive the grid to the zero voltage point. If the tube is not so operated, that is, if grid current is allowed to flow, the effect will be as though the secondary resistance is increased with a corresponding decrease in the value of Q . This will tend to cause a falling off in gain at the high frequencies.

It might seem that, since the strong notes in both speech and music occur at the lower frequencies, this would not be serious. However both speech and music are composed of very complex arrangements of frequencies, with both low and high frequencies with their overtones and harmonics occurring simultaneously. Thus losing part of the high frequency gain due to grid current on strong notes will

introduce distortion. If a resistance is connected across the transformer secondary, there is also a loss of gain at all frequencies just as if N were reduced. Grid current in the following tube acts just as resistance connected across the secondary, the more grid current flow the lower the value of the shunting R and the greater its effect. For these reasons the audio frequency amplifier cannot be overloaded. Special transformers must be used for Class B amplification where grid current is taken.

Audio frequency transformers can be designed to operate with any value of R_p ; but a large R_p requires a low ratio transformer as X_L must be made large also. Thus unless N is small, the high frequency range is limited due to excessive winding capacity. Therefore a high μ high R_p tube requires a low ratio transformer and there is no advantage in using high μ tubes with transformer coupling where flat gain over a wide frequency band is required.

AUDIO FREQUENCY TRANSFORMERS

Before studying the characteristics and factors which must be considered in the design of audio transformers, it is well to first consider the difference in working conditions of audio transformers and power transformers. Because the design of an ordinary power transformer is a comparatively simple matter, many persons are under the impression that audio transformers can likewise be designed by the use of simple tables and calculations. That is not correct. Outlining a few of the operating conditions of both:

Power Transformer:

1. Fed from a low resistance generator.
2. Voltage across the primary equals the generator voltage.
3. Voltage across the secondary equals NE_{primary} and the secondary is always loaded.
4. If the primary turns are reduced to one-half, then X_L of primary is only one-fourth as great and the primary current is increased by four times. Therefore $N/2$ turns $\times 4I =$ double the magnetic field strength with a corresponding doubling of the secondary voltage.
5. Designed to operate at a single frequency.

Audio Transformer:

1. Fed from a generator (tube) having a high resistance of several thousand ohms.

2. Operated with an open secondary as the input resistance of the following tube is very high.

3. Exciting current of the transformer is important as it may cause an appreciable drop in the generator (tube).

4. Reducing the primary turns increases the turns *ratio* N but the secondary voltage *may be decreased*. For example, in the lower frequency range where X_L approximates R_p ; if the primary turns are made 50 per cent less, the current will not increase materially as it is largely limited by R_p . Therefore the magnetic field is approximately only one-half as great (same I times $\frac{1}{2}$ the number of turns, $IN/2$) and the secondary voltage is reduced to one-half instead of being doubled.

In the design of the power transformer, which is to operate at a single frequency within specified voltage and current limits, the principal factors to be considered are current carrying capacity of the wire, the amount, shape and permeability of the iron in the core, the voltage step-up, etc. The inductance of the primary is comparatively low with X_L , under all normal operating conditions, far greater than the resistance of the generator. The capacity of the windings and the capacity between windings are not factors of design.

In the design of the audio transformer most of the operating conditions are reversed and some of the factors of major importance in power transformer design become relatively unimportant. The desirable factors in design of audio transformers are:

1. Large primary L . (Good low frequency response.)

2. High turns ratio. (High gain.)

3. High series resonant frequency. (Good high frequency response.)

Unfortunately these factors are not easy to obtain simultaneously. If a large primary inductance is desired to improve the low frequency response, then a low turns ratio N must be used, because if the number of secondary turns is large the equivalent secondary shunt capacity is large, with corresponding distortion at the high frequencies.

The leakage reactance can be reduced by interleaving the primary and secondary windings as in a power transformer to obtain a large value of K . This however tends to increase the equivalent capacity and to a certain extent nullifies the advantage gained by low leakage reactance.

Therefore uniform response over a wide band of frequencies can only be obtained by using large primary inductance and low turns ratio N , and being content with comparatively low gain per stage.

[At this point it should be pointed out that maximum gain per stage is a function of μN —that is, of both the tube amplification factor and the transformer turns ratio. It has been emphasized that the low frequency gain is a function of X_L/R_p where X_L is the transformer primary reactance. Thus the important factor in tube selection is low R_p rather than low μ . In the older types of tubes the two were practically synonymous. However considerable improvement has been made in tubes. For example, in the 27 tube $R_p = 9000$ ohms and $\mu = 9$. In the 6C5, $R_p = 10,000$ and $\mu = 20$. Thus in the more modern tube for essentially the same R_p , the amplification factor is more than double that of the older type.]

Good high frequency response requires low leakage reactance and low equivalent shunt capacity, therefore a low value of N . To reduce C_s the grid terminal should be *outside* and as far from ground as possible. Reversing the polarities of the transformer windings may very materially change the high frequency gain due to the change of capacity.

Changing the separation between windings changes C ; that is, increased spacing gives lower capacity but more leakage inductance. (This is poor design.) Most transformers are layer wound with paper between layers. One or more thicknesses of paper, treated or untreated may be used. Untreated paper tends to absorb moisture which decreases its insulating properties and therefore treated paper is sometimes used. However treated paper has a higher dielectric constant than untreated paper and introduces more capacity. A better design is to use untreated paper and then cover the entire ends of the coils with moisture proof varnish leaving the paper inside the coil unimpregnated and dry. The difference of spacing of the windings between one and two thickness of paper may vary the capacity

by more than 100 per cent. That is, a transformer having its windings separated by only one thickness of paper may have more than twice the effective capacity of one using a separation of two thicknesses of paper.

A large core or one of higher permeability allows the use of fewer turns for the same inductance. Thus by such design the inductance necessary for good low frequency response can be obtained with smaller equivalent capacity, which results in better high frequency response. It is an axiom in audio transformer design that one must use "plenty of iron and copper." Plenty of copper means sufficient turns for the required inductance and plenty of iron permits the use of the minimum number of turns to produce the required L with the minimum C. Of course as the number of primary turns for the required L is reduced, the number of secondary turns for a given step-up factor is reduced in proportion. The permeability of iron as ordinarily used in audio transformers under normal working conditions is about 300. At least one manufacturer uses permalloy for transformer cores in order to obtain the desired inductance with a minimum size of core.

The actual characteristics of a high grade audio transformer of one of the leading manufacturers are as follows:

Primary L = 85 Henries	Secondary Distributed C = 86 $\mu\mu\text{F}$
" R = 1400 Ohms	Interwinding C = 36 $\mu\mu\text{F}$
Secondary L = 762 Henries	Turns Ratio (N) = 3
" R = 6670 Ohms	K = .998
Primary distributed C = 335 $\mu\mu\text{F}$	Essentially uniform Response, 40 to 8000 cycles.

The ideal transformer turns ratio is equal to $\sqrt{R_g/R_p}$. The input grid resistance R_g of the second tube will normally be high and must be kept high by the use of a sufficiently high negative grid bias. Assume $R_p = 20,000$ ohms and $R_g = 1,000,000$ ohms. Then,

$$\text{Turn Ratio} = \sqrt{\frac{1,000,000}{20,000}} = \sqrt{50} = 7$$

However in practice such a high turns ratio cannot be used if uniform response over a wide frequency band is required. If the primary inductance of such a transformer is made sufficiently large

42

to allow good low frequency response, the distributed capacity of the secondary will be so great as to make the high frequency cut-off far too low. If the secondary turns are such that good high frequency response is assured, and the primary turns reduced in proportion, the primary inductance will be so small that the lower frequencies will be lost. Thus for high fidelity amplification N is usually from 1.5 to 3.5.

High gain peaked transformers have a use in radio telegraph work. Where high gain without the necessity of considering distortion is required, a transformer peaked between 600 and 1000 cycles with a very high value of N may be used. The received beat note between the CW signal and the local oscillator may be adjusted to the peak frequency and a very strong signal received with the minimum number of amplifier stages. The transformers used in some very cheaply built broadcast receivers, particularly midget receivers, have similar characteristics so that both high and low frequency response are poor.

AUDIO FREQUENCY VOLTAGE AMPLIFIERS

EXAMINATION:

1. Discuss the factors involved in the design of resistance coupled amplifiers.
2. Discuss the factors involved in the design of impedance coupled amplifiers.
3. What factors are important in audio transformer design? Why?
4. You wish to build a resistance coupled audio amplifier using Type 6AB4 tubes: $\mu = 60$, $R_p = 15,500$ ohms, $C_{G-P} = 1.5 \mu\text{f}$, $C_{G-K} = 2.2 \mu\text{f}$, $C_{P-K} = .5 \mu\text{f}$. You decide to use $R_L = .03$ megohm, $R_{GL} = .5$ megohm, $C_C = .02 \mu\text{f}$. Stray capacity is estimated at $20 \mu\text{f}$. What is the maximum gain per stage?
5. Reference Problem 4. Calculate the gain at 30 and 100 cps.
6. Reference Problem 4. Calculate gain at 1000, 5000, 10000, and 15000 cps.
7. Draw a curve showing the response of one stage of the amplifier in *decibels* from 30 to 15,000 cps.
8. Reference Problem 7. On the same curve show by means of a dotted line the improvement in one stage of the amplifier of Problem 4 if C_C is changed to $.2 \mu\text{f}$.
9. You wish to build a transformer coupled amplifier using Type 6S4 tubes. The transformer has a primary inductance of 60 henries, a step-up ratio of 2.5, coupling coefficient $K = .996$, capacity of secondary windings $80 \mu\text{f}$ and capacity between windings $40 \mu\text{f}$. $\mu = 16$, $R_p = 3,600 \Omega$.
Calculate gain at 30, 1000, 6000 and 15,000 cycles.
10. (A) Find the frequency of series resonance for problem 9 conditions, which is the frequency where peak gain is obtained.

(B) Find the gain at the frequency calculated in (A).

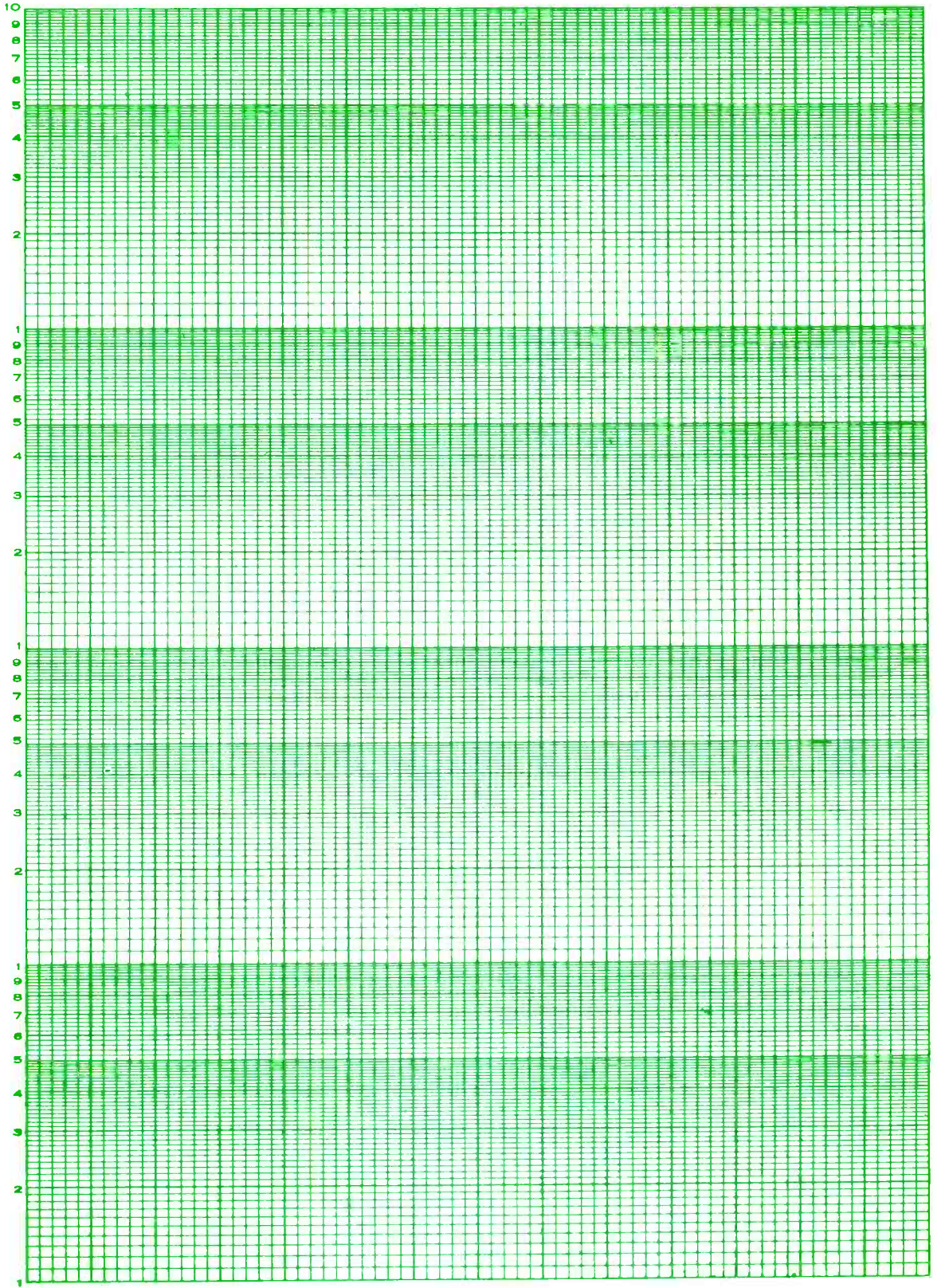

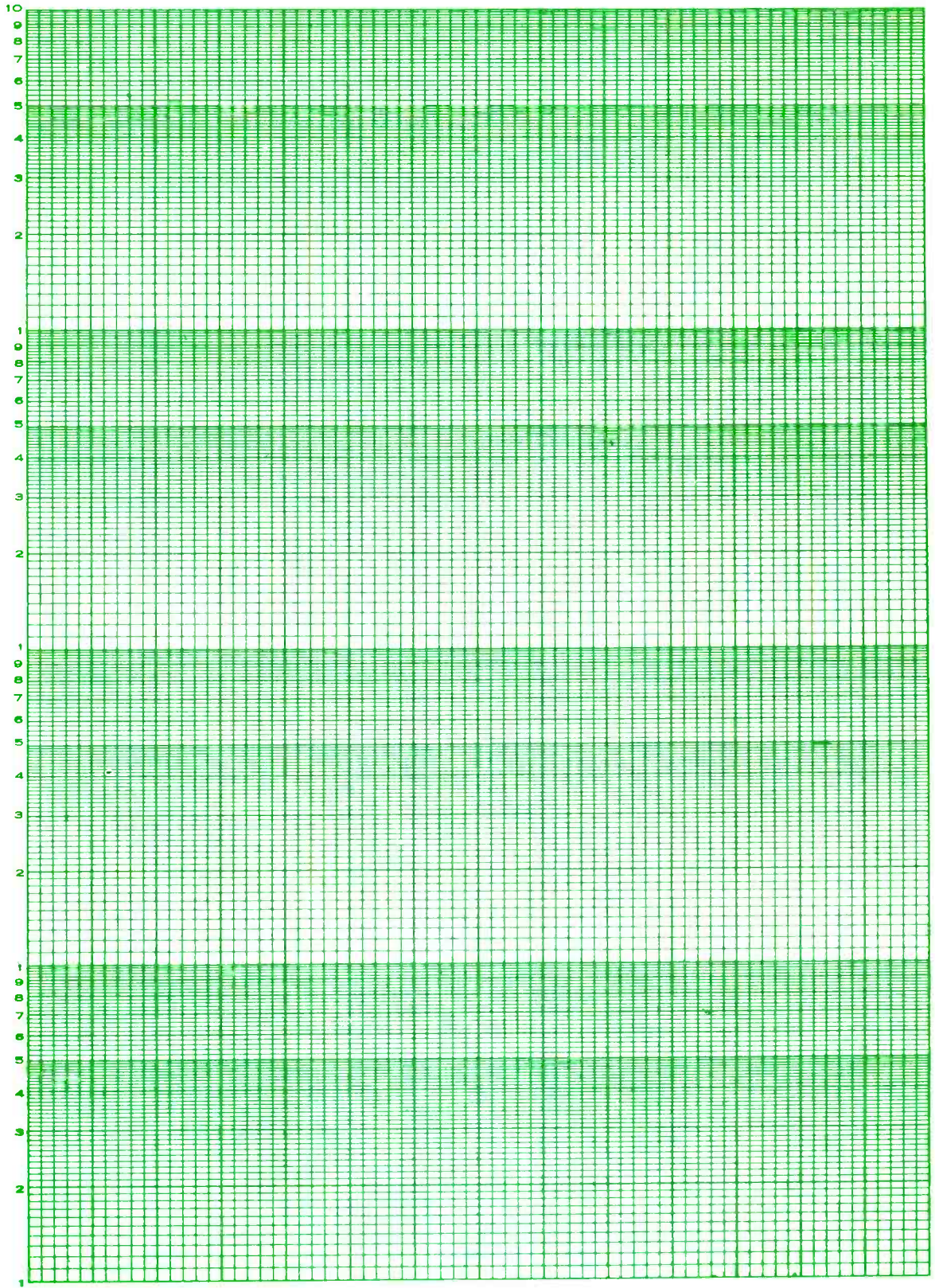

1950

1951

1952



SECTION 3

**SPECIALIZED BROADCAST
RADIO ENGINEERING**

**TECHNICAL ASSIGNMENT
AUDIO POWER AMPLIFIERS**

Copyright 1941 by
Capitol Radio Engineering Institute
Washington, D. C.

303 D

TABLE OF CONTENTS—

AUDIO POWER AMPLIFIERS

	Page
<i>Type 6F6</i>	2
<i>Type 6F5</i>	2
OPERATING EFFICIENCY.	8
OUTPUT VS INPUT	9
CLASS AB OPERATION.	10
BIASING THE CLASS AB AMPLIFIER.	14
PENTODE POWER AMPLIFIERS.	18
THE BEAM POWER AMPLIFIER TUBE	23
CIRCUIT FOR USE WITH THE BEAM POWER AMPLIFIER	29
PARALLEL POWER AMPLIFIER TUBE OPERATION	34
TUBE TO LOAD IMPEDANCE MATCHING	35
TABLE I.	37
CLASS B AUDIO AMPLIFIERS.	38
INVERSE FEED-BACK APPLICATIONS	53

BROADCAST ENGINEERING

AUDIO POWER AMPLIFIERS

In the previous discussion of audio amplifiers--types of tubes and coupling systems--it has been assumed that maximum undistorted *voltage* amplification is desired. However the ultimate aim of an audio amplifier is to furnish *power* at audio frequencies to drive one or more reproducer units, to deliver audio frequency power to a long telephone line, or to modulate the R.F. carrier of a transmitter.

It is easily possible, by the use of high- μ tubes and the proper coupling system, to obtain very large audio frequency voltages. However, in the case of the high- μ tube, R_p is large and the plate current is correspondingly small. The power delivered to the load resistance R_L is equal to $I^2 R_L$; thus a reduction in I substantially reduces the power output of the tube.

A comparison between the operating conditions and power outputs of two receiver type audio amplifier tubes--one a high- μ voltage amplifier triode Type 6F5 and the other a power amplifier pentode Type 6F6 used with a triode connection (screen tied to plate)--will make this point clear. Both are to be operated Class A.

The basic equation for the operation of a vacuum tube is,

$$I_p = \frac{\mu E_s}{R_p + Z_L} \quad \text{Equation 1}$$

If E_s is maximum value then I_p will be maximum value. E_s is the excitation voltage applied to the grid and I_p is the alternating component of plate current.

The operating characteristics of the two tubes being considered are shown in Figures 1 and 2. Figure 1 shows the characteristic of the power amplifier, triode connection, in which $\mu = 7$ and $R_p = 2600$. Figure 2 illustrates the characteristics of the high- μ voltage amplifier triode. Both tubes will be operated with plate potential of 250 volts.

AUDIO POWER AMPLIFIERS

Type 6F6: (Triode Connection). $E_p = 250$ V, E_g (bias) = -20 V, $R_p = 2600$ ohms, $\mu = 7$, $Z_L = 4000$ ohms (recommended value). Assume maximum value of E_s to be 20 volts, just sufficient to swing E_g to zero. Then, from Equation 1,

$$I_p = \frac{\mu E_s}{R_p + Z_L} = \frac{7 \times 20}{2600 + 4000} = \frac{140}{6600} = .0212 \text{ ampere.}$$

But since $E_s = 20$ volts is a maximum value and power is calculated from R.M.S. values, the maximum value of $I_p = .0212$ ampere must be converted to the R.M.S. value by multiplying by .707. Then,

$$I_p = .0212 \times .707 = .015 \text{ ampere (R.M.S.)}$$

If Z_L is pure resistance, then,

$$P = I^2 R = .015^2 \times 4000 = .9 \text{ watt.}$$

Peak E (across load) = $IR = .0212 \times 4000 = 84.8$ volts.

Type 6F5: $E_p = 250$ V, E_g (bias) = -2 V, $R_p = 66,000$ ohms, $\mu = 100$, $Z_L = .2$ megohm. Assume maximum value of E_s to be 2 volts, just sufficient to swing E_g to zero.

Then, from Equation 1,

$$I_p = \frac{\mu E_s}{R_p + Z_L} = \frac{100 \times 2}{66,000 + 200,000} = \frac{200}{266,000} = .00075 \text{ ampere}$$

I_p (R.M.S.), $I_p = .707 \times .00075 = .00053$ ampere.

$$P = I^2 R = .00053^2 \times 200,000 = .056 \text{ watt.}$$

Peak E (across load) = $IR = .00075 \times 200,000 = 150$

It will be observed that in the case of the high- μ Type 6F5 the maximum voltage variation is considerably greater than in the low- μ 6F6 (150 volts as compared with 84.8 volts) for only one-tenth the value of E_s (2 volts as compared with 20 volts). Therefore the 6F5 is a much better voltage amplifier.

However with a greater voltage developed across a much higher value of load resistance (200,000 ohms as compared with 4000 ohms), the power output of the voltage amplifier is only about one-sixteenth as great as the output of the power amplifier, (.056 watt as com-

AUDIO POWER AMPLIFIERS

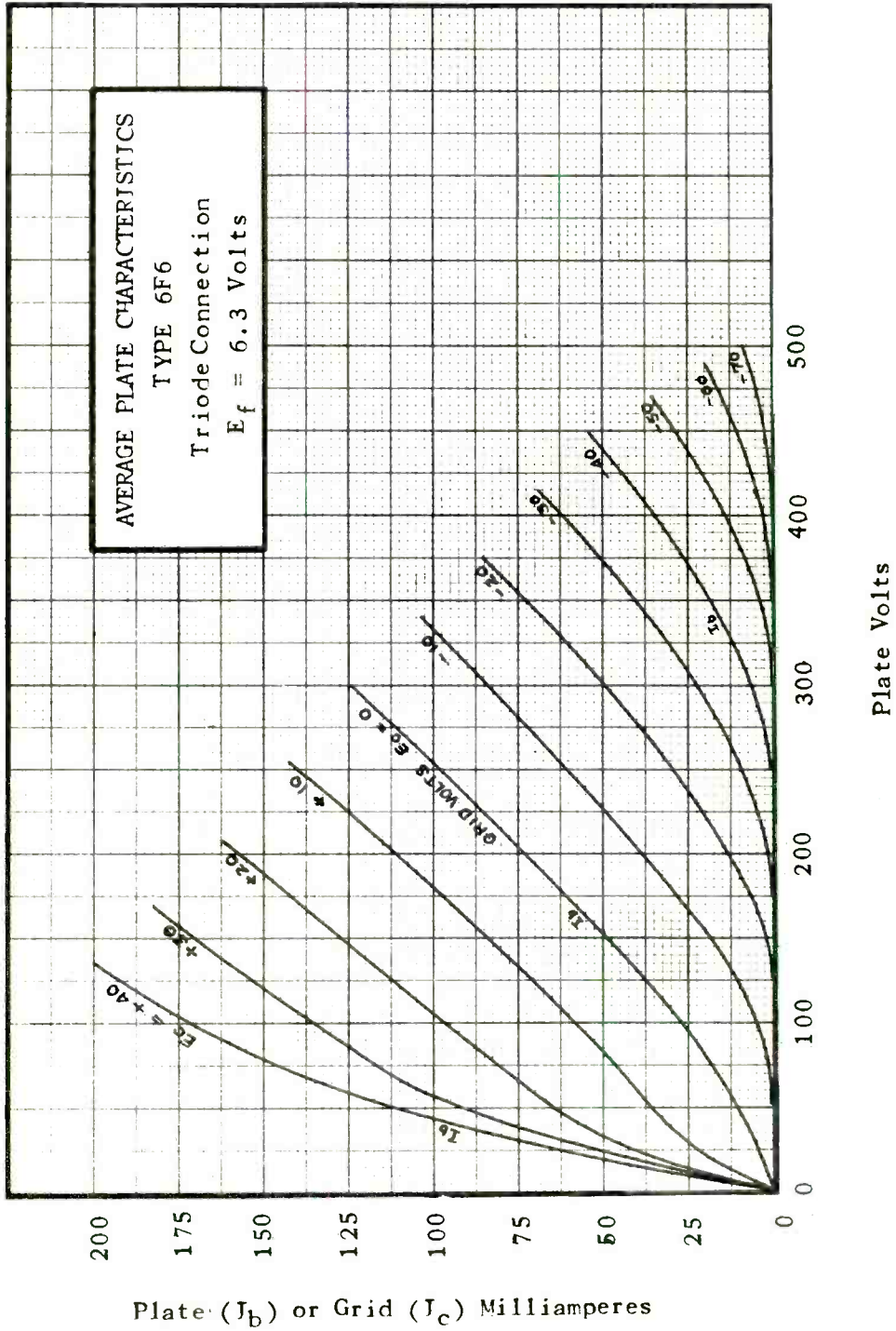

Fig. 1.

AUDIO POWER AMPLIFIERS

AVERAGE PLATE CHARACTERISTICS

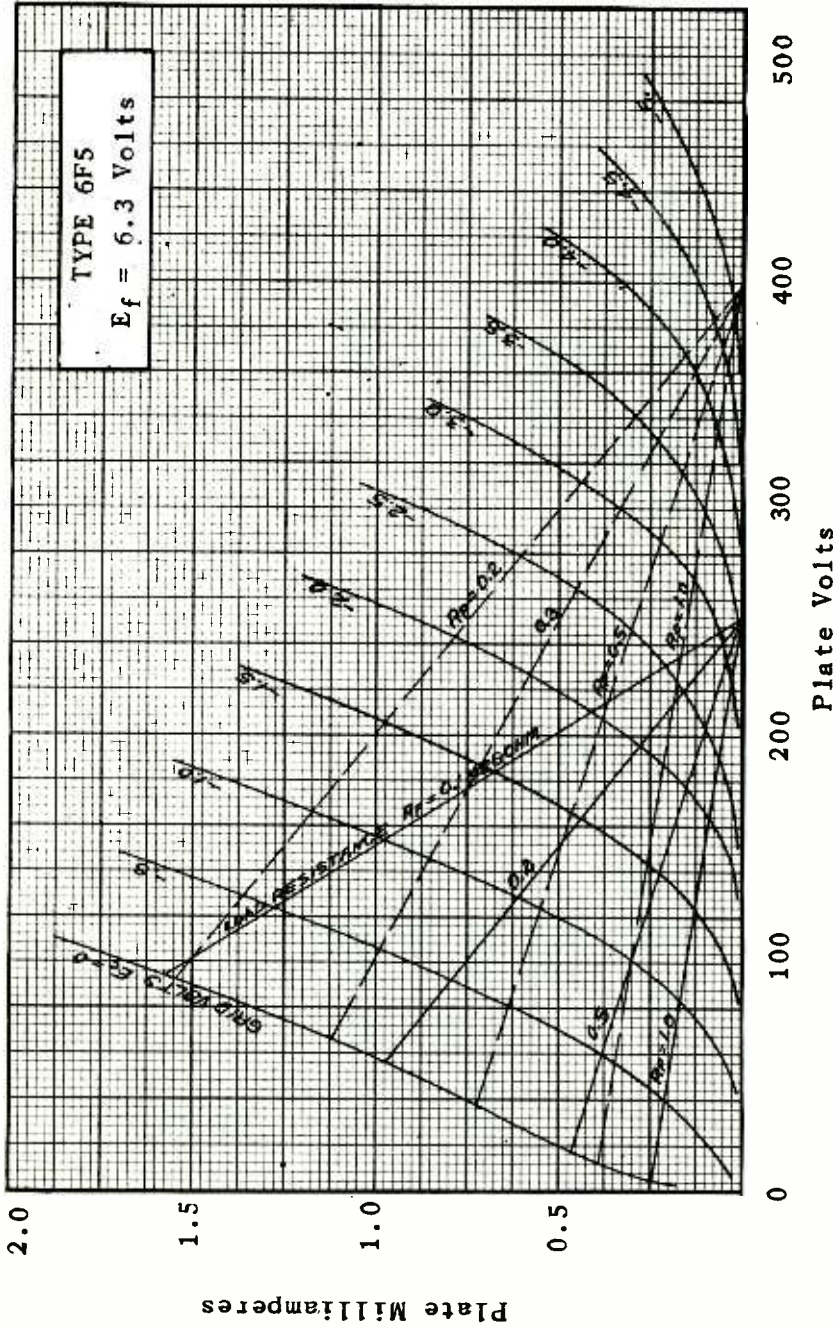

Fig. 2.

AUDIO POWER AMPLIFIERS

pared with .9 watt). The power amplifier delivers sixteen times as much power with slightly more than one-half the plate voltage swing of the voltage amplifier, across a load resistor 1/50th as large. The difference is due to the low R_p of the power tube which permits a large A. C. component of plate current for comparatively small values of plate voltage, the power being a squared function of I and a linear function of R .

In all power tube operation the maximum power output will be obtained when $Z_L = R_p$. However, in the case of a triode, this ratio will not give the *maximum undistorted power output*, the latter being obtained when Z_L approximates $2R_p$. Thus in an audio amplifier a certain amount of power output must be sacrificed to minimize distortion. The loss of power output however is only about 10 per cent. That is, the power output obtained with $Z_L = 2R_p$ is approximately 90 per cent of the maximum obtained when $Z_L = R_p$.

To avoid amplitude distortion in a Class A amplifier:

1. The grid must not swing positive.
2. The tube must be operated *only* along the straight portion of the dynamic $E_g I_p$ characteristic curve and the grid voltage must not be allowed to swing into the lower bend of the curve.
3. To permit maximum E_g , the load impedance must be correct because the slope of the load line is equal to $1/Z_L$.

For a given tube the maximum undistorted power output can be obtained only with proper values of E_p , E_g , R_p and Z_L , and (for Class A operation) with E_g such that on the positive alternation the grid voltage just swings to zero and on the negative alternation reduces I_p just to the low region beyond which excessive amplitude distortion would be introduced.

The proper grid bias voltage E_g is a function of E_p , R_p and Z_L . For *maximum* power output the correct bias is expressed by the following equation:

$$-E_g = \left(\frac{E - E_1}{\mu} \right) \left(\frac{Z_L + R_p}{Z_L + 2R_p} \right) \quad \text{Equation 2}$$

Where

E_g = negative grid bias

E_b = plate voltage at the operating point.

AUDIO POWER AMPLIFIERS

E_1 = plate voltage required to develop allowable minimum I_p that will exist during the signal cycle when $E_g = 0$. This value of bias so locates the operating point that when,

1. Signal swings +, E_g goes to 0.
2. Signal swings -, I_p is reduced to the minimum allowable value.

Example: Type 6F6. (Triode Connection). $E_b = 250$ V; $R_p = 2600$ ohms; $\mu = 7$; minimum I_p about 12 mils; at 0 bias 60 volts E_p required for plate current of 12 mils, therefore $E_1 = 60$.

(The minimum current of 12 mils is taken from the curves by inspection, based upon experience and the amount of permissible harmonic distortion. As an approximate guide, the minimum current is selected at the point where the characteristic curvature starts to increase abruptly. If later calculations show the harmonic content to be too high this minimum current value may have to be raised; if the distortion is found to be well within the allowable amount the minimum current value may be lowered with a resulting increase in usable output power).

If $Z_L = R_p$, from Equation 2,

$$-E_g \text{ (bias)} = \left(\frac{250 - 60}{7} \right) \left(\frac{2600 + 2600}{2600 + 5200} \right) = \frac{190}{7} \times \frac{5200}{7800} = 18 \text{ volts.}$$

Audio power amplifiers (Class A triodes) usually are operated with $Z_L = 2R_p$ to reduce amplitude distortion. Under this condition the second member of Equation 2 becomes,

$$\frac{2R_p + R_p}{2R_p + 2R_p} = \frac{3R_p}{4R_p} = .75$$

Then,
$$-E_g = .75 \left(\frac{E_b - E_1}{\mu} \right)$$

This is the equation for the correct bias for any Class A triode audio power amplifier when $Z_L = 2R_p$.

Assuming the same limiting conditions for the 6F6 previously taken except that Z_L approximates $2R_p$ instead of R_p ,

$$-E_g = .75 \left(\frac{250 - 60}{7} \right) = 20 \text{ volts.}$$

AUDIO POWER AMPLIFIERS

This is the value taken in the first calculation for the power output. (-20 volts was used in the calculation of Equation 1). It will be noted that as Z_L is increased, the correct bias also is increased.

For given bias voltage the proper value of Z_L may be obtained by transposing Equation 2.

$$Z_L = R_p \left[\frac{-E_g}{\frac{E_b - E_1}{\mu} + E_g} - 1 \right]$$

For the Type 6F6 tube operated as a Class A triode with bias of -20 volts and I_p limited to 12 mils at zero grid bias, which from the curve of Figure 1 brings the low limit of plate voltage to 60 volts,

$$Z_L = 2600 \left[\frac{-(-20)}{\frac{250 - 60}{7} - 20} - 1 \right] = 4680 \text{ ohms.}$$

It will be seen that to properly predict the operation of a power amplifier it is necessary to have a complete set of characteristic curves similar to those in Figures 1 and 2. With such curves at hand, the calculations may be quickly checked by drawing in the load line.

In an earlier lesson it was shown that, while maximum power output can be obtained from a tube when $Z_L = R_p$, the *undistorted* power output is greater when $Z_L = 2R_p$ than when $Z_L = R_p$. The undistorted power output obtainable from a tube is given by Equation 3. (Undistorted power output assumes that the vector sum of all harmonic components does not exceed 5 per cent of the fundamental).

$$P = (E_b - E_1)^2 \frac{Z_L}{2(Z_L + 2R_p)^2} \quad \text{Equation 3}$$

This represents the maximum obtainable undistorted output *only* when $Z_L = 2R_p$ as is clearly shown by the calculations below.

With the 6F6 triode connected: Assume $Z_L = R_p = 2600$ ohms. Consider $E_1 = 60$ volts as in the above calculations.

$$P = (250 - 60)^2 \frac{2600}{2(2600 + 5200)^2} = 190^2 \times \frac{2600}{2(7800)^2} = .77 \text{ watt.}$$

AUDIO POWER AMPLIFIERS

When $Z_L = 2R_p$ Equation 3 becomes, $P = \frac{(E_b - E_1)^2}{16R_p}$

$$P = \frac{(250 - 60)^2}{16 \times 2600} = .87 \text{ watt.}$$

When $Z_L = R_p$, only .77/.87 or 88 per cent as much undistorted power output can be obtained as when $Z_L = 2R_p$, although the ratio is almost reversed when considering only maximum output without emphasis on a minimum percentage of distortion. With some triodes the optimum Z_L is appreciably greater than $2R_p$.

OPERATING EFFICIENCY

When the amplifier tube is operated Class A--that is, within the limits of the straight portion of the $E_g I_p$ curve--the power supplied by the source is independent of the presence of the signal. The d.c. plate voltage is fixed and the plate current varies equally above and below the "no signal" point. Thus when there is no signal all the input power $E_b I_b$ is expended in heat at the plate of the tube. In average speech or music the peak power output is required only about one-fifth of the time; the remainder of the time the actual power output is only a fraction of the full capacity of the tube and the efficiency is very low with most of the input power expended within the tube. Thus the plate of a Class A power amplifier tube will run cooler when delivering full output than when there is no signal. When a signal is present the tube dissipation is reduced by the amount of the tube power output.

$$\text{Maximum Plate Efficiency} = \frac{\text{Maximum Power Output}}{\text{Power Input}} = \frac{Z_L}{2(Z_L + 2R_p)}$$

Equation 4

It will be seen that when Z_L is very large compared with R_p , the maximum ideal efficiency of 50 per cent is approached.

When $Z_L = 2R_p$, the usual operating condition, the efficiency approaches 25 per cent as a maximum. However, if the tube is sufficiently excited to operate at efficiency approaching this maximum, distortion will be excessive.

$$\text{Efficiency} = \frac{2R_p}{2(2R_p + 2R_p)} = \frac{R_p}{4R_p} = .25 = 25 \text{ per cent.}$$

AUDIO POWER AMPLIFIERS

With the Type 6F6 tube operated as shown above with $E_p = 250$, $E_g = -20$, $Z_L = 2R_p = 5200$ ohms, $I_p = 29$ mils (from the curve of Figure 1), and $P = .87$ watt,

$$\text{Actual Plate Efficiency} = \frac{.87}{250 \times .029} = .12 = 12 \text{ per cent.}$$

This is less than half the possible plate efficiency with $Z_L = 2R_p$ but the poor efficiency is necessary to avoid prohibitive distortion.

With a smaller value of E_s , since the power input would not be decreased, the efficiency would be still less. Thus the average operating efficiency of a Class A power amplifier tube is very low and this fact must be taken into consideration when designing an audio amplifier to supply a given output, particularly if the audio power required is large, as in the case of certain types of modulators.

OUTPUT VS INPUT

It particularly should be noted that the maximum power output of a tube is obtained *only* when sufficient E_s is available to drive it. Thus the substitution of a larger power tube in an amplifier, while it will increase the *capacity* of the amplifier to handle a larger signal, will not in itself produce a larger output. For example, a comparison is given above between the operating capabilities of the 6F5 and the 6F6. In the former, E_s of only 2 volts is sufficient to drive the tube to maximum undistorted output, while in the case of the latter, E_s of 20 volts is required. If a 6F6 is substituted for a 6F5, *less* and not more output will be obtained with the same driving source due to the much lower μ of the power tube.

When operating large power tubes Class A (as in the case of certain modulators) the power loss at the plate *may* be excessive when calculated values of bias and Z_L are used. Under such conditions I_p must be decreased by one of two methods:

1. Reduce E_p . This will lower the power input and the efficiency.
2. Increase the bias and calculate the correct Z_L . With the increased bias Z_L must be increased with resulting higher efficiency.

In the case of the small receiver type tubes the actual power loss and heating of the plate during normal operation usually are not serious. However, with the larger tubes used in large public address systems and as modulators in transmitters, the operating efficiency is a very important factor and must be given careful consideration in design.

CLASS AB OPERATION

The particular disadvantages of the Class A amplifier are low operating efficiency and small power output. The latter is due to the small allowable grid voltage swing, the E_g swing being limited by the lower bend of the $E_g I_p$ curve and by the zero grid point. The small power output is of course responsible for the low operating efficiency. A reference to any set of power tube characteristic curves will show that if the two limits described above are neglected and the grid swing is allowed to considerably exceed those values, the tube power output will be greatly increased. Consider the curves of Figure 3. E_{s1} illustrates the excitation of a tube biased and operated as a Class A amplifier. The plate current variations are shown as I_{p1} and are symmetrical above and below the zero E_s point hence there is no amplitude distortion.

In E_{s2} and E_{s3} the tube is operated Class AB, biased more negatively than in the case of E_{s1} . For E_{s2} , the plate current variations of which are shown in I_{p2} , the I_p variations are still essentially linear and the tube is operating--for this small signal voltage--as a Class A amplifier. However, in E_{s3} a signal voltage of greater amplitude is impressed on the grid, swinging it positive on one alternation and below I_p cut-off on the second alternation. This is shown in I_{p3} . The output is now far from symmetrical and considerable amplitude distortion is introduced.

The amplitude distortion is cancelled out by operating two tubes in pushpull. The result is shown in Figure 4. In this figure, although actually the current variations are 180° out of phase, they are shown in phase because, taking place through opposite windings on the center-tapped transformer primary, *their effects on the secondary winding are in phase*. The total primary current variation is shown in (c) [I_p , Tube 1 + Tube 2]. This is the effective current variation by means of which a voltage is induced in the secondary winding and hence across the load. It will

be observed that in (c) the amplitude distortion is effectively balanced out, the total I_p variation being symmetrical although the

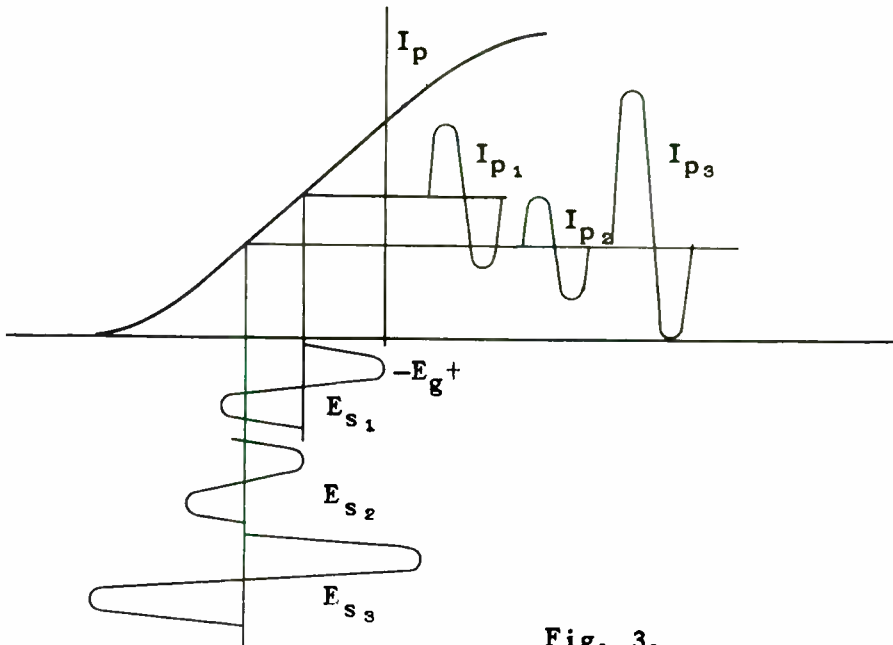

Fig. 3.

output of each tube is badly distorted. This is the manner in which a pushpull circuit balances out second and all even harmonic distortion.

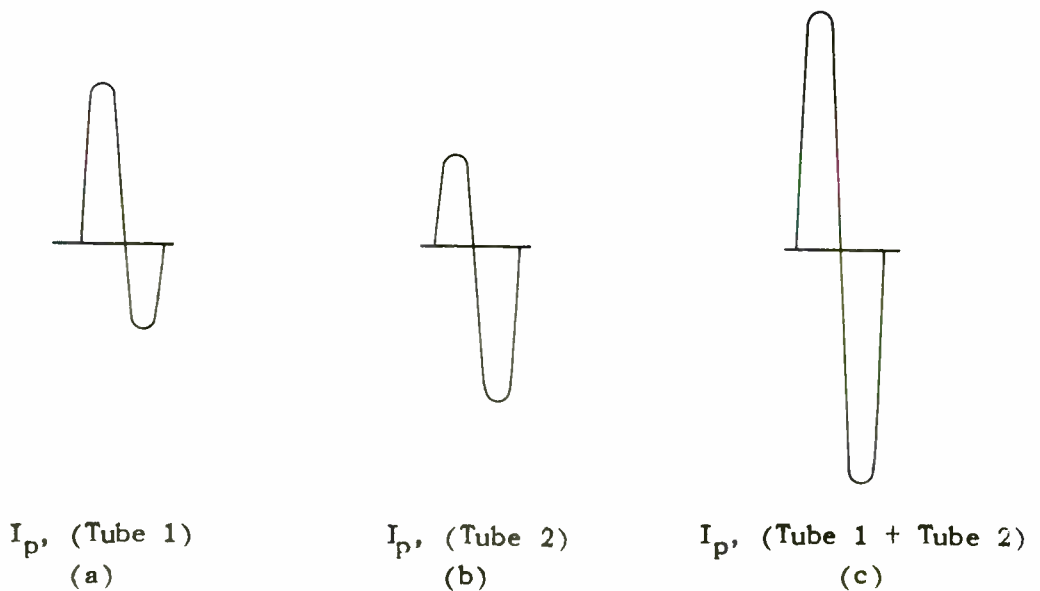

Fig. 4.

The third harmonic distortion, due to grid current when the grid is allowed to swing positive and due to symmetrical curvature

AUDIO POWER AMPLIFIERS

of the $E_g I_p$ characteristic, cannot be cancelled out by the use of a push-pull circuit. It is minimized by the use of a driver stage of sufficient power to maintain linearity of grid voltage even when the power amplifier grids swing positive and the load impedance into which the driver works decreases sharply; by the use of a low impedance grid circuit so that the change of load on the driver stage is not abrupt even when the grids take current and the input resistance drops; by keeping the grid excitation within reasonable limits and not overworking the power tubes; and by the proper selection of plate voltage and load impedance to permit the most nearly linear $E_g I_p$ characteristic.

It has been shown that operated as a Class A triode the 6F6 will deliver a maximum output of approximately .9 watt, with $E_p = 250$ and $E_g = -20$. When two 6F6 tubes are operated as Class AB₂ triodes with $E_p = 350$ and $E_g = -38$, the two tubes will deliver power output of approximately 13 watts, or 6.5 watts per tube, with slightly less total harmonic distortion. Thus the available output per tube (with this type of tube) is between seven and eight times greater when operating Class AB than when operating Class A. (A triode connection is assumed in both cases). To drive the Class AB push-pull 6F6 amplifier operated as explained above, a single 6F6 operated Class A with the voltages previously given may be used. With this circuit arrangement the driver should operate into a minimum plate load of 10,000 ohms, with input transformer ratio--primary to one-half secondary--of 1.67. (The latter figures are taken from the manufacturer's tube manual).

It should be noted that by operating Class AB₂ the operation on large signal voltage very closely approaches Class B operation with consequent high operating efficiency. This is clearly indicated by the fact that E_p of 350 volts can be used as compared with 250 volts for Class A operation, and by the power output of 6.5 watts per tube as compared with .9 watt when operated Class A. The large power increase is accomplished with a decrease in distortion (3 per cent as compared with 5 per cent). However, the 3 per cent distortion in the Class AB amplifier is due almost entirely to 3rd and other odd harmonics because the 2nd and all even harmonics are balanced out by the push-pull circuit.

Class AB amplifiers further may be subdivided into Class AB₁ and Class AB₂. The difference is in the permissible amplitude of

AUDIO POWER AMPLIFIERS

the excitation voltage. In the Class AB₁ amplifier *the grid is not allowed to swing positive*. Thus the operation is essentially Class A except that the increased negative bias permits greater excitation voltage and increased power output with, however, greatly increased second harmonic distortion due to operation in the region of lower curvature. This can be balanced out by push-pull operation. The problems of design introduced when E_g is allowed to swing positive with accompanying grid current flow are not present. The driver design is exactly the same as for a Class A amplifier.

A Class AB₂ amplifier is one in which the excitation is increased into the region of positive grid swing. In this region grid current flows and the tube input resistance drops sharply with resulting decrease in the effective load impedance of the driver stage. This necessitates an entirely different design of the input transformer and imposes completely different requirements on the driver tube.

The figures given above for Class AB operation of the 6F6 assume AB₂ operation.

As an example of the difference in maximum power output under the two conditions the following figures taken from a manufacturer's tube manual are interesting.

Type 6L6. (Two tubes, fixed bias)

	Class AB ₁	Class AB ₂
Plate voltage	360	360
Screen voltage	270	270
Grid bias voltage	-22.5	-22.5
Peak A.F. grid-to grid E.	45	72
Load resistance (plate-to-plate)	3800	3800
Total harmonic distortion	2 percent	2 percent
Maximum power output	18 watts	47 watts

With the same plate and bias voltages and load resistance, by increasing the peak-to-peak excitation voltage from 45 to 72 volts, the maximum power output is increased in Class AB₂ operation 2.6 times from 18 watts to 47 watts. However, the actual design of the input circuit and the driver stage are completely different for the two conditions. In the case of AB₁ operation, even resistance coupling with a voltage amplifier type of driver tube may be used

very satisfactorily. With Class AB_2 operation the driver tube must be of the power type and a step-down transformer having a low resistance secondary winding is necessary.

BIASING THE CLASS AB AMPLIFIER

The problem of biasing a Class AB amplifier is somewhat different than that of biasing a Class A amplifier. In the Class A amplifier the d.c. plate current should be constant whether a signal is applied to the grid or not, because the variation of plate current with signal is equal above and below the d.c. value, the average therefore remaining unchanged with excitation. That being the case, the bias may be obtained simply by the use of a cathode resistor as shown in Figure 5. This is called a "self-bias" arrangement because the bias is obtained directly from the plate current of the tube being biased. $R = E/I$ where E is the negative bias required

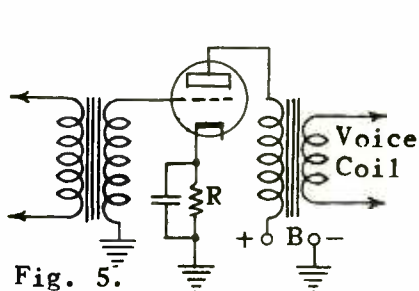

Fig. 5.

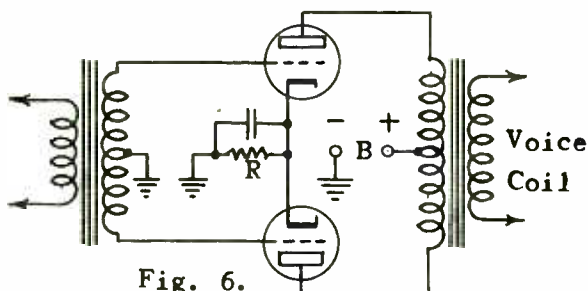

Fig. 6.

and I is the plate current of the tube being biased. Thus if the negative bias should be -20 volts and $I_p = 31$ mils, $R = 20/.031 = 645$ ohms.

Figure 6 illustrates a push-pull circuit. If each tube in Figure 6 is operated with the same E_p , E_g and I_p as the tube in Figure 5, then in the push-pull circuit R should have exactly one-half the resistance of R in the single tube circuit or $645/2 = 322.5$ ohms. For practical purposes values of 650 ohms and 325 ohms would be entirely satisfactory.

In the Class AB amplifier the circuit is exactly as shown in Figure 6. However, the operating conditions are different. Both plate voltage and negative bias ordinarily are greater, the bias always being greater than for Class A. As shown in Figure 3, for small signal voltages the tube operates essentially Class A and the self-bias arrangement of Figure 6 is still satisfactory. Assume that a bias of -28 volts is required and that the no-signal plate

AUDIO POWER AMPLIFIERS

current of each tube is 25 mils making the plate current for the pair of tubes 50 mils. Then $R = E/I = 28/.050 = 560$ ohms.

For small signals the tubes operate Class A with fixed bias of -28 volts. Consider now the case of a strong peak signal--such as E_{s3} in Figure 3--which persists for several cycles. During the interval of this signal voltage I_p averages considerably greater than I_b . Assume that during the signal peak the I_p average per tube is 37 mils. Since R is fixed, the voltage across it varies directly as I_p . Then $E_g = IR = .074 \times 560 = -41.4$ volts as compared with the normal bias of -28 volts. Thus as soon as the signal voltage drives the tube beyond Class A operation, the bias slides back and forth, increasing with signal peaks and approaching normal for smaller signals.

It will be seen that this varying bias introduces a variable voltage component into the tube input that is not present in the original signal. This of course introduces even order harmonic distortion but not to so great an extent as might be thought. Both tubes are affected equally by the varying bias, with the result that such variations cancel out in the output transformer and are not passed on as distortion to the reproducer. The principal distortion introduced by the varying bias is to the complex higher frequencies (overtones and harmonics) of small amplitude which accompany the large amplitude frequencies, and which may be lost if the bias is pushed back beyond I_p cut-off.

Thus the principal effect of the varying self-bias is to limit the power that can be taken from certain types of tubes to somewhat less than is possible with a fixed bias, for the same permissible percentage of harmonic distortion. As an example, in the manufacturer's specifications for two 6F6's operated as triodes Class AB_2 , rated power output with fixed bias is 13 watts, with self-bias 9 watts. With two 2A3 triodes operated Class AB_1 , the power output rating with fixed bias is 15 watts with 2.5 per cent harmonic distortion; with self-bias, 10 watts with 5 per cent harmonic distortion. The 2A3 operated Class A will deliver undistorted power output of 3.5 watts, or about one-half its capacity per tube when operated Class AB_1 with fixed bias.

When it is desired to use fixed bias so that greater output can be obtained with less--or not more--distortion, the bias voltage must be taken from a source which is not entirely dependent on the

AUDIO POWER AMPLIFIERS

CLASS AB AUDIO-FREQUENCY AMPLIFIER
Output 12 Watts

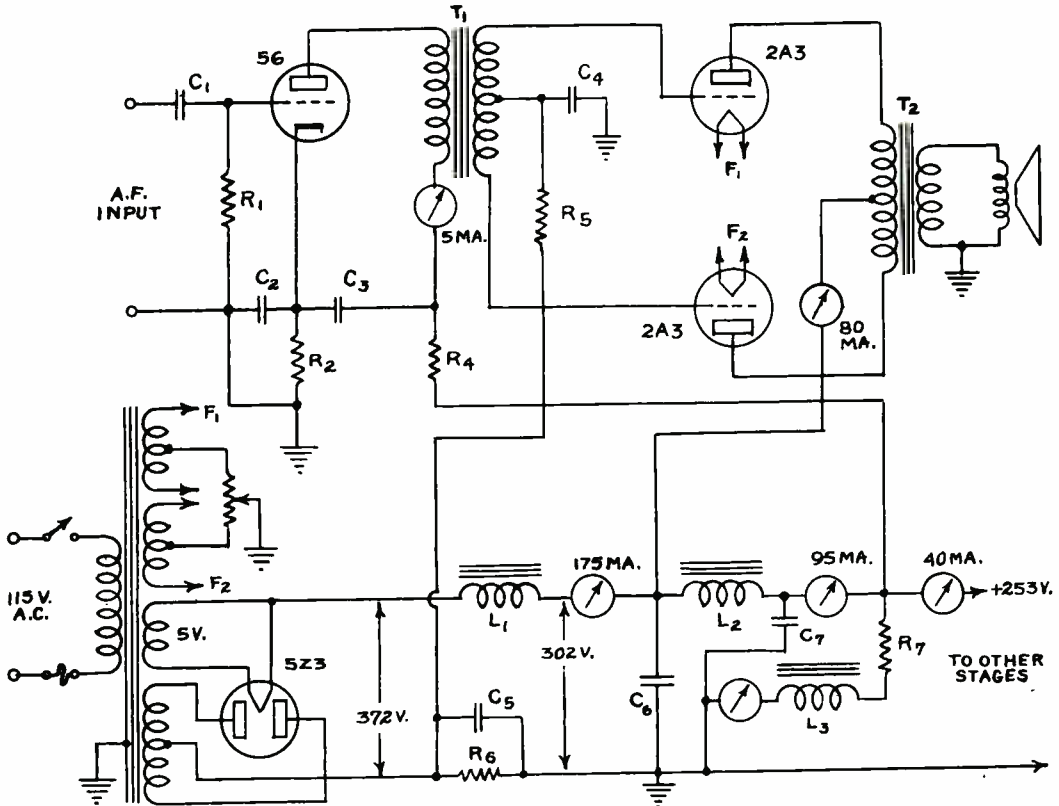

$C_1 = 0.1$

$C_2 = 5 \mu f, 25 \text{ V.}$

$C_3 = 2 \mu f, 350 \text{ V.}$

$C_4 = 0.5 \mu f$

$C_5 = 25 \mu f, 75 \text{ V.}$

$C_6 = 10 \mu f, 400 \text{ V.}$

$C_7 = 8 \mu f, 350 \text{ V.}$

$R_1 = 0.5 - 1 \text{ megohm}$

$R_2 = 2200 \text{ ohms, 1 watt}$

$R_3 = 100\text{-ohm potentiometer}$

$R_4 = 5000 \text{ ohms, 1 watt}$

$R_5 = 50,000 \text{ ohms, 1 watt}$

$R_6 = 345 \text{ ohms, 15 watts}$

$R_7 = 2560 \text{ ohms, 10 watts}$

$L_1 =$ Filter choke; 12 henries at 175 MA., 60 ohms

$L_2 =$ Filter choke; 30 henries at 95 MA., 515 ohms

$L_3 =$ Speaker field; 2500 ohms, 125 V.

$T_1 =$ Plate-to-push-pull-grid input transformer

$T_2 =$ Output transformer

$T_3 =$ Power transformer having good voltage-regulation characteristics

Note: A speaker specially designed for high power is recommended. Circuit constants should closely approximate those given above.

Fig. 7.

AUDIO POWER AMPLIFIERS

plate current of the power tubes being biased. Figure 7 shows a typical class AB audio frequency amplifier employing a semi-fixed bias circuit. The bias resistor R_6 has a resistance of 345 ohms. With plate potential of 300 volts, a bias of -62 volts is required. 60 volts of this is taken as the drop across R_6 so that the current through R_6 must be $E/R = 60/345 = .175$ ampere = 175 mils. Of this, from the diagram, 80 mils is the plate current of the power tubes and 95 mils is derived from the other tubes and the speaker field.

The right hand side of R_6 connects to ground and the left hand side to the negative rectifier terminal. The 2A3 filaments connect directly to ground through the bias-balancing potentiometer R_3 . The 2A3 grids connect directly to the negative side of R_6 through filter R_5C_4 . Thus the voltage drop across R_6 is applied as bias between the grids and filaments of the 2A3's. The only cause for variation of the bias voltage will be peak plate current variations in the 2A3's. This effect is made negligible by the large capacity C_5 of 25 μ F across R_6 which acts as a filter to maintain a constant voltage across the resistor. With such a large filter condenser the bias voltage fluctuations are made negligible. This would not be true if a sufficiently large value of C_5 were not used. Without such a capacity filter, signal peaks would cause voltage fluctuations across R_6 .

Potentiometer R_3 in Figure 7 is used to permit the tube biases to be individually adjusted for balanced operation. If the potentiometer slider is set at exact center, a small self-bias of $IR = .04 \times 50 = 2$ volts per tube is obtained. This adds to the negative bias of 60 volts established across R_6 and provides up to 2 volts variation either way to allow the operating characteristics of the tubes to be balanced. The effect of this small amount of self-bias is negligible in-so-far as the variations due to signal peaks are concerned, but balancing of tube characteristics is particularly important in the case of the 2A3 tubes due to their high mutual conductance. With most other tubes it will not be necessary to use separate filament transformers and the potentiometer.

In some large public address systems and in the modulator systems of transmitters where an accurately fixed bias must be maintained, a separate small rectifier is used for that purpose. That of course is economically impractical for most amplifiers and arrangements like that shown in Figure 7 should prove satisfactory.

AUDIO POWER AMPLIFIERS

Figure 8 shows the average plate characteristics of a 2A3, with a load line drawn in for Class A operation with $E_p = 250$ volts, $E_g = -43.5$ volts. Some idea of the individual tube amplitude distortion introduced in large signal Class AB operation can be had by moving the operating point back along the load line to $E_p = 300$ volts, $E_g = 62$ volts. The load line is drawn for $R_L = 2500$ ohms, the recommended value for Class A operation. Figure 8 also shows the load line for $R_L = 750$ ohms, the recommended Class AB value, (per tube). The 750 ohm load line will be much steeper than for 2500 ohms and of course the per-tube distortion will be more apparent. The 750 ohm load line as drawn in Figure 8 passes through the operating point ($E_p = 300$, $E_g = -62$) at an angle such that $\text{Tan } \theta = 2(10^3/R_L)$, correction being made for the scale to which the curves are plotted, e.g., 50 mils, 100 volts.

PENTODE POWER AMPLIFIERS

The theory and operation of the pentode power amplifier have been discussed. At this point the discussion will be limited largely to the use of the pentode and calculations of power output and distortion. The power-amplifier pentode is simply a screen grid tube in which an additional grid--called the suppressor grid--is placed between the plate and the screen grid and connected, usually internally, to the cathode. The function of the suppressor grid is to prevent a large component of reverse current from the plate to the screen grid due to secondary emission on the lower peak of the E_p cycle when the plate voltage is very low compared to the screen voltage. Typical power amplifier pentodes are: 2A5, 42, and 6F6. These tubes may also be operated as triodes by connecting the screen to the plate.

The power pentode may be operated Class A single tube or push-pull, or push-pull Class AB. Operated Class AB there is little difference between triode and pentode operation, although due to the greater power sensitivity of the pentode it requires somewhat less driving voltage for maximum power output than does the triode. However, where a single tube is to be operated Class A the pentode has very definite advantages of greater power output and higher power sensitivity, although the harmonic distortion is somewhat higher. An example of this is the 6F6. Operated as Class A triode with $E_p = 250$ volts, $E_g = -20$ volts and $R_L = 4000$ ohms, power output

AUDIO POWER AMPLIFIERS

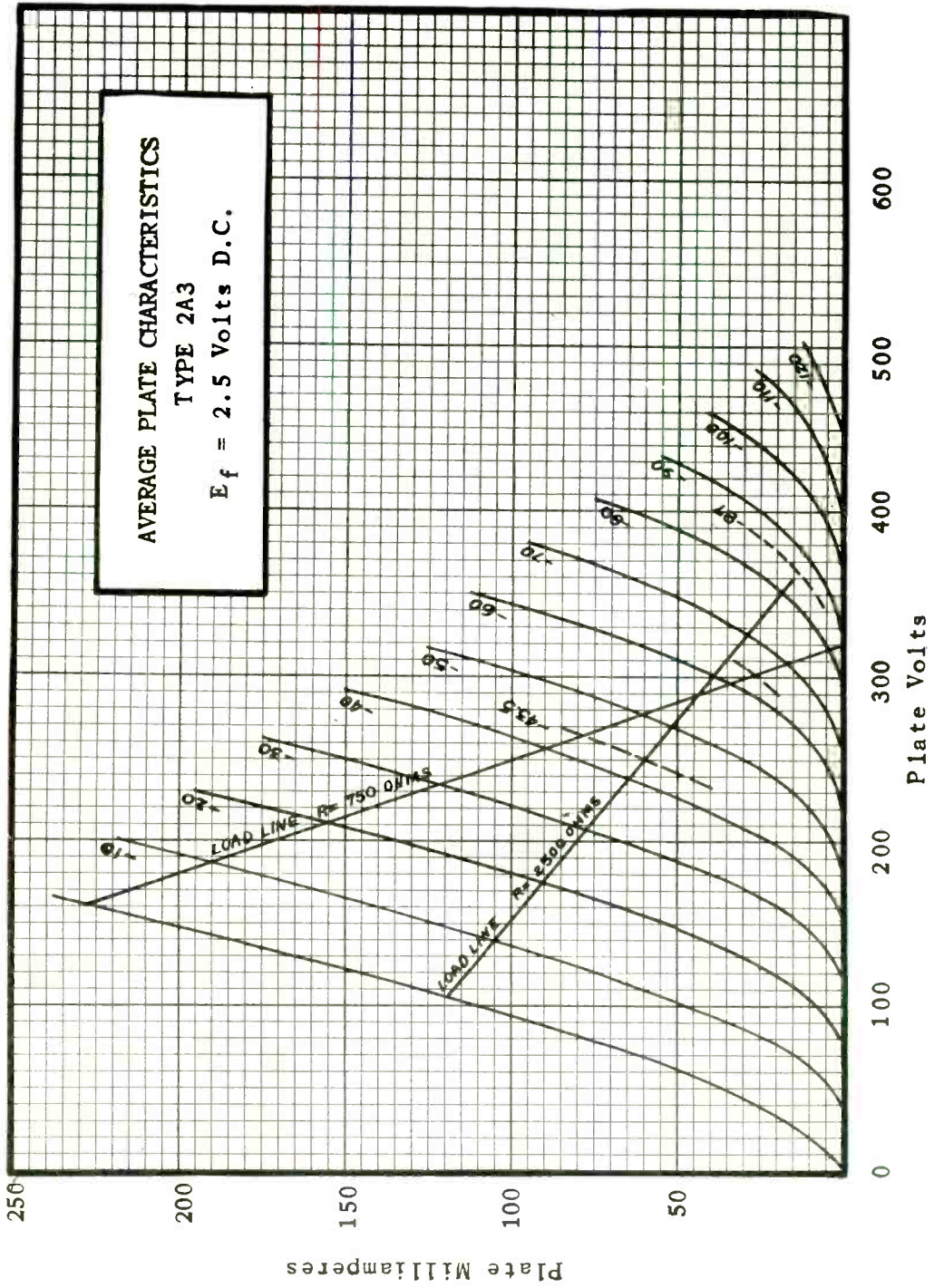

Fig. 8.

AUDIO POWER AMPLIFIERS

is .85 watt with 6.5 per cent harmonic distortion. Operated as Class A pentode with $E_D = 250$, $E_{(\text{screen})} = 250$, $E_g = -16.5$ volts and $R_L = 7000$ ohms, power output is 3.2 watts with 8 per cent distortion. The distortion is only slightly greater and the power output is more than three times as great.

Due to the much higher amplification factor of the screen grid tube, a pentode will deliver the same power output as a triode with smaller grid signal voltage. Thus in a small inexpensive receiver the power pentode may be driven directly from the detector, eliminating the first audio stage and still having good power output capacity on strong signals. This is not an important factor in the design of broadcast equipment.

Figure 9 shows the average plate characteristics for the 6F6 with pentode connection. This may be compared with Figure 1 which shows the average characteristics of the same tube with triode connection. With $E_p = 250$, E_g should be -16.5 volts. This point is shown on the Figure. From the shape of the curves, it is evident that a fairly small value of load impedance is necessary if serious distortion is to be averted. Recommended Z_L for this tube is 7000 ohms.

Figure 10 shows the manner in which the load line analysis is used with the pentode to calculate power output and distortion. (The theory of this analysis is explained in an earlier lesson). The load line is drawn in at an inclination determined by Z_L . For maximum power output the grid is allowed to swing around the operating point between zero E_g and $2E_g$.

The load line for $Z_L = 7000$ ohms is drawn in Figure 9. $\tan \theta = \frac{10^3}{Z_L} = .143$. The scale ratio 100 volts/50 mils requires that the tangent be doubled with the result that the load line is drawn in at an angle of 16° . Using the solution of Figure 10,

$$P = \frac{[I_{\max} - I_{\min} + 1.41(I_x - I_y)]^2 R_L}{32} \quad \text{Equation 5}$$

The current I_x is read at the point where the load line intersects the plate characteristic drawn for a grid voltage of .293 times the bias voltage. In this example the I_x value is read at the point where the load line intersects the -4.83 volt characteristic $[.293 \times -16.5]$ and is 60 mils.

The current I_y is read at the point where the load line in-

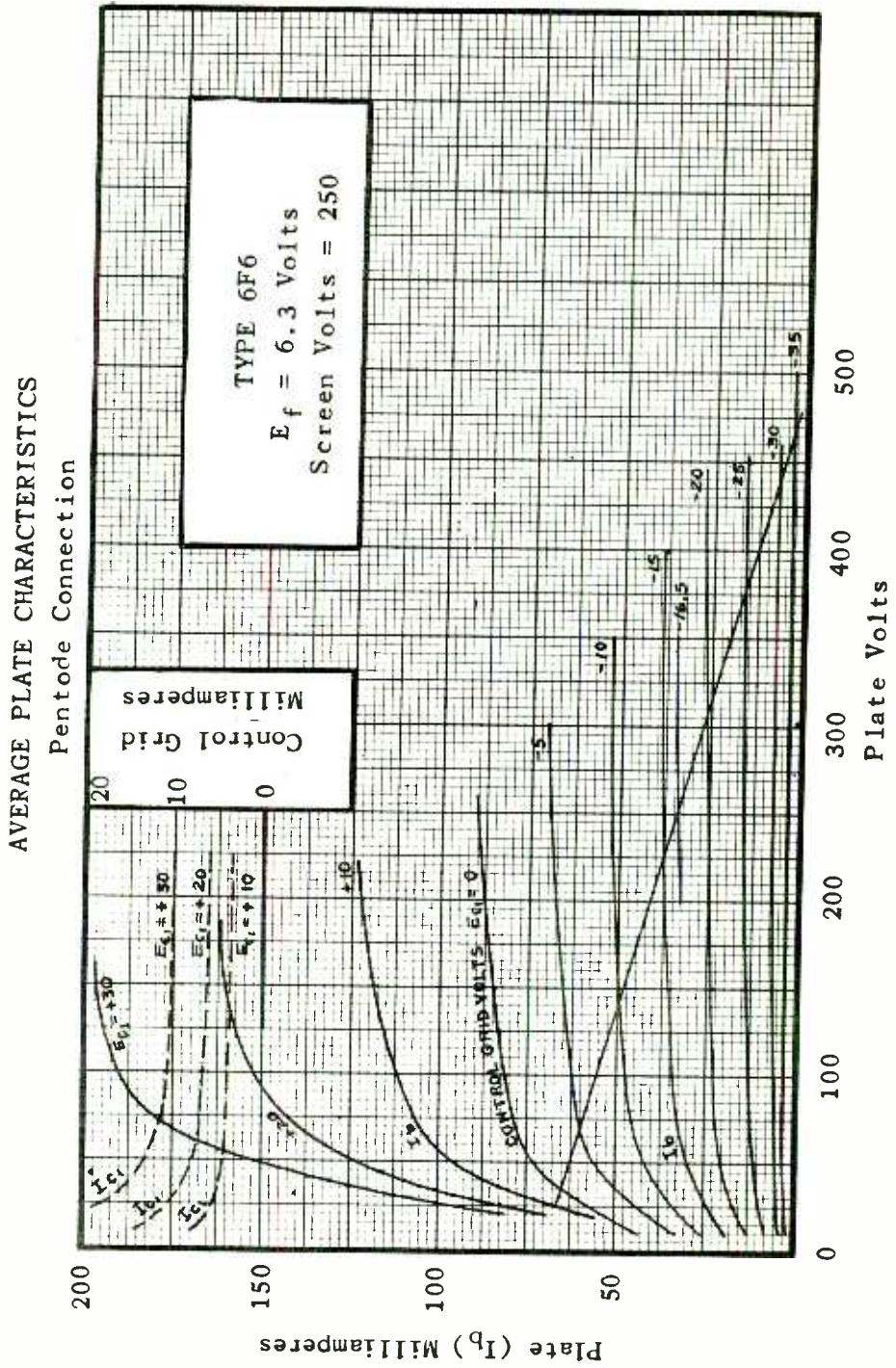

Fig. 9

AUDIO POWER AMPLIFIERS

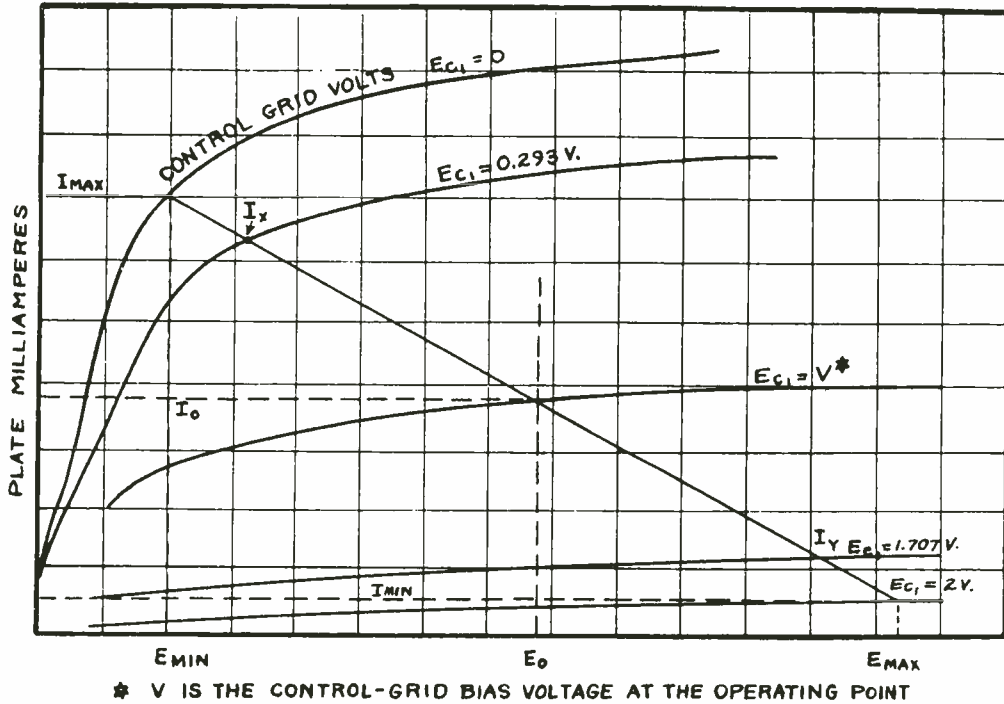

Fig. 10.

tersects the plate characteristic drawn for a grid voltage of 1.707 times the bias voltage; $1.707 \times 16.5 = -28.16$ volts. This current is 9 mils.

From the tube curves, Figure 9, the factors of Equation 5 first must be determined. These are found to be:

$$I_{\max} = 65 \text{ mils.}$$

$$I_{\min} = 4 \text{ mils.}$$

$$I_x = 60 \text{ mils.}$$

$$I_y = 9 \text{ mils.}$$

$$I_0 = 34 \text{ mils.}$$

Then, by Equation 5,

$$P = \frac{[.065 - .004 + 1.41(.06 - .009)]^2 \times 7000}{32} = 3.9 \text{ watts.}$$

Next is calculated the harmonic distortion (2nd and 3rd) from the factors determined above.

AUDIO POWER AMPLIFIERS

$$\begin{aligned} \% \text{ 2nd Har. Dist.} &= \frac{I_{\max} + I_{\min} - 2I_o}{I_{\max} - I_{\min} + 1.41(I_x - I_y)} \times 100 \quad \text{Eq. 6} \\ &= \frac{.065 + .004 - 2(.034)}{.065 - .004 + 1.41(.06 - .009)} \times 100 = 0.75 \text{ percent.} \end{aligned}$$

$$\begin{aligned} \% \text{ 3rd Har. Dist.} &= \frac{I_{\max} - I_{\min} - 1.41(I_x - I_y)}{I_{\max} - I_{\min} + 1.41(I_x - I_y)} \times 100 \quad \text{Eq. 7} \\ &= \frac{.065 - .004 - 1.41(.06 - .009)}{.065 - .004 + 1.41(.06 - .009)} \times 100 = 8.2 \text{ percent.} \end{aligned}$$

$$\begin{aligned} \text{Percent Total (2nd and 3rd) Harmonic Distortion} \\ &= \sqrt{(\text{Percent 2nd})^2 + (\text{Percent 3rd})^2} \quad \text{Eq. 8} \\ &= \sqrt{.75^2 + 8.2^2} = 8.23 \text{ percent.} \end{aligned}$$

These figures agree fairly well with the typical rated characteristics as listed by the manufacturer. The power output as calculated is slightly high and the percentage of harmonic distortion is nearly identical. All measurements from which the results were calculated were made directly on Figure 9 without enlargement. Of course for a greater degree of accuracy the curves must be plotted to a much larger scale.

It should be noted in the solution of Equation 7 that the amount of the numerator comes out--in this particular case--to a negative value. It may work out either + or -. Where the negative sign results, simply disregard the sign.

THE BEAM POWER AMPLIFIER TUBE

In the consideration of power amplifier tubes, several points stand out very forcibly. First: with conventional receiver type tubes operated Class A, the power output of one, or even two tubes in push-pull, is not sufficient to handle the signal peak power that may be desired with the present inefficient dynamic speakers used in home receivers and in broadcast station monitors. This has been compensated for to a considerable extent by Class AB operation, but similar limitations still apply if the grid swing is to be restricted to the zero E_g point. When the grid is allowed to swing positive taking grid current, high order harmonics are

AUDIO POWER AMPLIFIERS

developed which can be very annoying to the listener. Second: when for greater power sensitivity than is possible with triodes, pentodes are used, either Class A or Class AB, considerable 3rd harmonic distortion results. This distortion of course cannot be cancelled by the use of a push-pull circuit.

The source of 3rd harmonic distortion in pentodes is in the *gradual bend* of the $E_p I_p$ characteristic at low plate voltages and low grid voltages. This is clearly shown in Figure 9. The load line swings into the gradual $E_p I_p$ bend at about -5 volts and the condition becomes more pronounced as the zero grid line is approached. Thus even though the grid is not allowed to actually swing positive, the condition exists for the generation of odd harmonic distortion and it will be even more aggravated if the grid swings actually positive in Class AB operation. It will be seen from the $E_p I_p$ curves that the odd harmonic distortion can be decreased by decreasing Z_L to make the inclination of the load line greater. This however results in greatly decreased power output.

The reason for the gradual bend of the $E_p I_p$ curve in the region of low control grid voltage is the over-effectiveness of the suppressor grid under such conditions. The suppressor grid is used to prevent the drop of plate current due to secondary emission electrons going in the reverse direction from the plate to the screen grid. This function is accomplished satisfactorily in the conventional pentode. However consider another condition. As the control grid voltage approaches zero from a more negative value, I_p must increase. This increased plate current through the load resistor results in decreased plate voltage and, as seen from the curves, E_p reaches a quite low value at zero E_g if normal Z_L is used. As this point is approached, the plate voltage is quite low compared with the screen voltage. Electrons pass through the screen grid going toward the plate, and to get to the plate must also pass through the suppressor grid. In going from a high positive potential toward a lower potential the electrons slow down. As they closely approach and pass through the suppressor grid, they come under the influence of the positive plate and again accelerate. If the plate potential is sufficiently high it can counteract the slowing down due to the zero potential suppressor grid, but at low plate potential the plate loses its effectiveness to some extent, and many of the electrons slow down to the point where they cannot proceed against the at-

traction of the positive screen grid and thus return to the screen instead of continuing to the plate. This of course reduces the plate current from what it would be if all electrons passing through the screen grid could reach the plate.

The ideal $E_p I_p$ characteristic would be one in which the curve was flat all the way to zero E_p , at which point I_p would drop suddenly to zero. In the curves of Figure 9 the characteristic is essentially flat to about $E_p = 75$ volts. At lower values of E_p the curves gradually bend downward. Consider the curves of Figure 11. Here the characteristic curves are essentially linear almost to the point where they suddenly drop off. The load line is drawn in for $E_p = 250$, $E_g = -14$, $Z_L = 2500$. The load line does not intersect

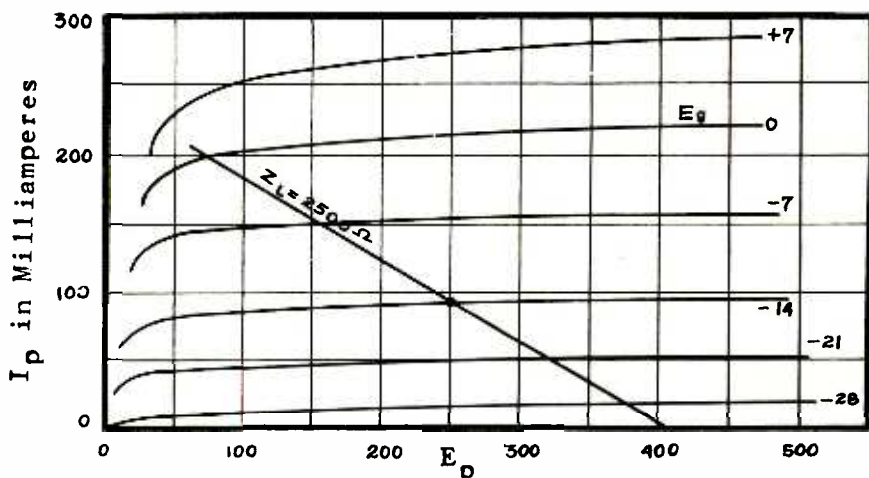

Fig. 11.

a curved portion until just as the grid swings to the zero E_g point, therefore the odd harmonic distortion is very small. The cramping of the curves at high values of $-E_g$ clearly indicates that considerable 2nd harmonic amplitude distortion will result. However, this can easily be cancelled out by push-pull operation of two tubes, or by introduction of a 180° out-of-phase component in a preceding amplifier stage if only one power tube is to be used.

The curves of Figure 11 appear to be those of an idealized pentode. Actually they are the curves of the "beam" power amplifier tube one type of which is the 6L6. The beam power amplifier is a tetrode (four element) screen grid tube which operates as an ideal pentode but without a suppressor grid, suppression being accomplished by means of the electron space charge between the screen grid and the plate.

AUDIO POWER AMPLIFIERS

A number of years ago it was discovered, by means of a fluorescent coating on the inner wall of a tube plate, that by certain combinations of plate and grid voltages, the electrons would pass between the grid wires and proceed to the plate in the form of distinct beams. Considerable research during recent years has resulted in a large accumulation of data on the formation of electron beams, this research finally resulting in the commercial development of the beam power amplifier tube. Space is not available at this point to go into detail on the formation of electron beams. Only the practical application of the beam principle in power tubes will be pointed out.

In Figure 12 is shown schematically a cross section of a triode. The grid is biased negatively. The manner in which the

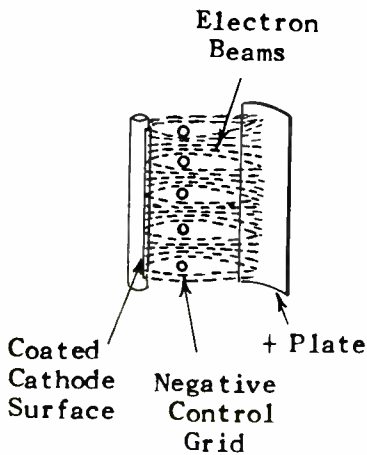

Fig. 12.

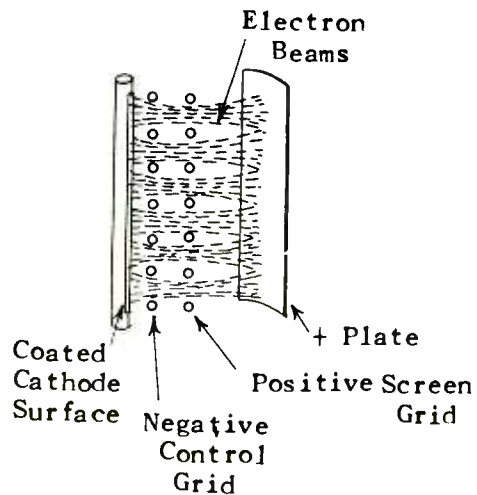

Fig. 13.

electrons pass between the grid wires on their way to the plate is clearly shown. It will be observed that *directly* behind each negative grid wire (between the grid and the plate) is a space in which there are practically no electrons. In Figure 13 is shown the manner in which that space is used to advantage. The screen grid contains exactly as many turns as the control grid and each screen grid turn is *directly behind* the corresponding control grid turn so that it is out of the electron beam and even though it is at quite high positive potential, only a small proportion of the total electrons go to the screen grid. (In practice the screen current will average something in the order of one-tenth the plate current with full signal voltage applied to the grid, and usually about

one-half that percentage with zero signal voltage). Thus screen grid action is obtained with the loss of very little of the available plate current to the screen.

Next consider the space between the screen and the plate. As the beams approach the plate they diverge and at a short distance in front of the plate the beam effect discontinues and the entire plate surface is effectively bombarded by electrons. This means there is a dense cloud of electrons formed in front of the plate, the cloud forming a negative space charge. As secondary electrons are dislodged from the plate and start toward the screen, they meet this negative space charge, are slowed down, and return to the plate. Thus suppression is accomplished just as by the suppressor grid in a pentode.

The effectiveness of the suppressor action depends upon the electron concentration in the space charge. This same effect is present in any screen grid tube to some extent but adequate suppression at low plate voltage is not obtained because the electron space charge is not sufficiently dense. Therefore further beam concentration must be obtained. Consider Figure 14. This is a view of the

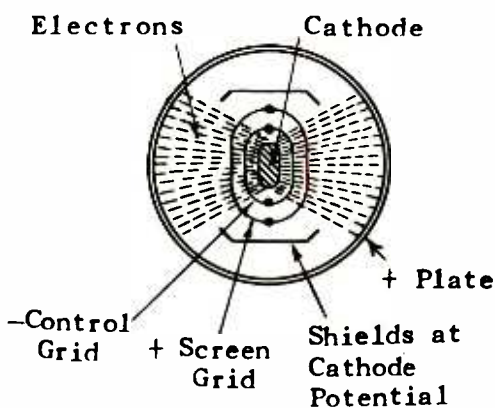

Fig. 14.

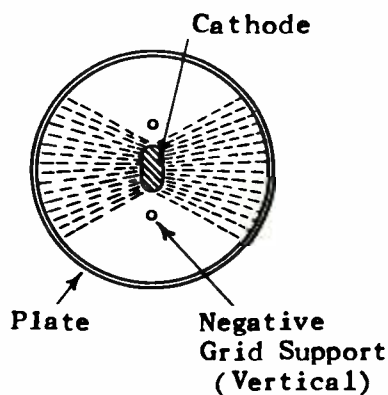

Fig. 15.

tube from above showing the element arrangement. The cathode and the two grids are so shaped as to produce two opposite relatively flat surfaces. At each end of the structure are the vertical grid supports which, in the case of the negative control grid, tend to force the electrons into beams as shown in Figure 15. This of course concentrates all the available electrons into a much smaller cross-section making the electron density at every point greater and

AUDIO POWER AMPLIFIERS

increasing the effectiveness of the suppressor action.

In order that secondary electrons cannot return to the screen outside the beam, metal shields connected internally to the cathode and of course at cathode potential are placed as shown. These shields have an effect outside the beams just as the suppressor grid in a pentode.

In Figures 16 and 17 are shown the actual arrangement of elements in a typical beam power amplifier tube. The concentrated negative space charge immediately in front of the plate is clearly shown in Figure 17. Operated Class A with $E_p = 250$, $E_{sg} = 250$, $E_g = -14$ and $Z_L = 2500$, a single 6L6 tube will deliver 6.5 watts with 9.7 per cent 2nd harmonic and 2.5 per cent 3rd harmonic distortion. With

INTERNAL STRUCTURE OF TYPE 6L6 BEAM POWER TUBE

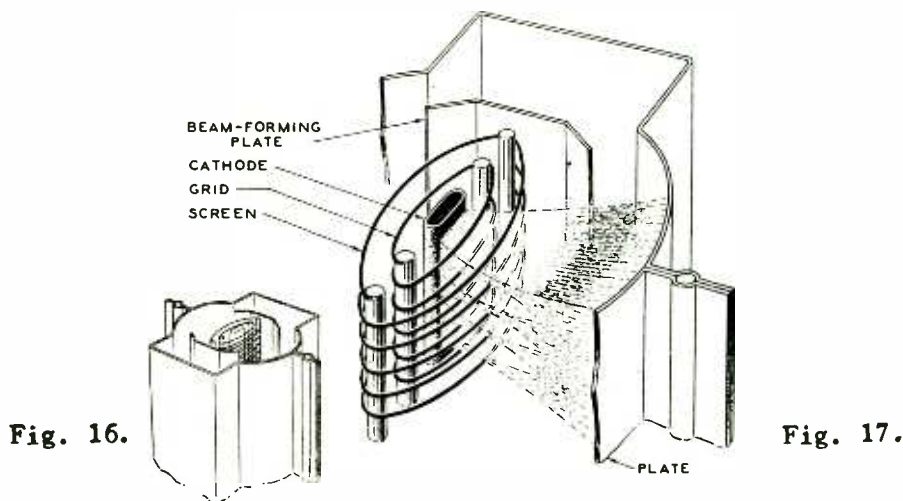

two tubes in push-pull Class A, $E_p = 250$, $E_{sg} = 250$, $E_g = -16$, Z_L (plate to plate) = 5000, output of 14.5 watts can be obtained with only 2 per cent 3rd harmonic, the large 2nd harmonic of course cancelling out. With two tubes operated Class AB push-pull with $E_p = 400$, $E_s = 300$, $E_g = -25$, Z_L (plate to plate) = 6600, and the grid not allowed to swing positive, power output of 34 watts can be obtained with only 2 per cent 3rd harmonic. Operated with similar voltages with Z_L (plate to plate) = 3800 ohms and allowing the grids to swing positive 15 volts, output of 60 watts can be obtained with 2 per cent 3rd harmonic distortion. In this latter case peak driving power of 350 milliwatts is required and the driver must be capable of supplying that amount of power without distortion when the power amplifier grids swing positive.

CIRCUIT FOR USE WITH THE BEAM POWER AMPLIFIER.

The conventional push-pull circuit may be used with the beam power amplifier. However one bad feature of pentode operation is also common to the beam tetrode; that is, at the frequency of speaker resonance efficiency rises sharply, and with high resistance tubes this produces a tendency toward "booming" which may be very annoying and detrimental to the speaker. With low resistance triodes such as are commonly used as power amplifiers, the low tube resistance loads the speaker to the point where resonant booming does not occur. The beam power amplifier has the high R_p characteristic of the pentode and with its greater power output it usually is necessary to take steps to minimize the effect of speaker resonance. A practical method of accomplishing this is to use an inverse feed-back circuit to produce a certain amount of degeneration. A typical circuit with circuit constants is shown in Figure 18.

By adjustment of the inverse feed-back circuit any required amount of damping can be obtained. The circuit operation and the necessity for damping at speaker resonance may be explained by reference to Figure 18.

Assume that a signal voltage is applied to the power tube grids at a very low frequency with sufficient voltage amplitude

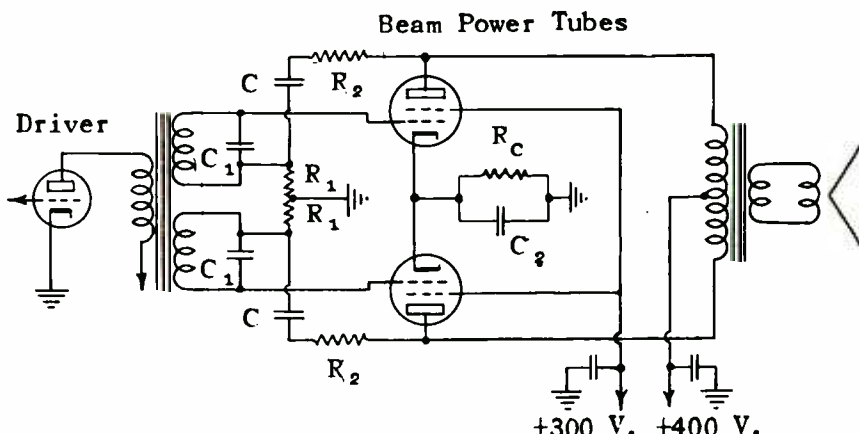

- $R_1 = 10,000$ } or $5,000$ } for 10% feed-back
- $R_2 = 90,000$ }
- $R_c =$ Self-bias resistor
- $C = 0.1 \mu f$ or larger
- $C_1 =$ Value depends on secondary impedance of transformer and should be determined by test. Large values require a series resistor to prevent transients.
- $C_2 = 35\text{-Volt electrolytic condenser (50 } \mu f)$

Fig. 18.

AUDIO POWER AMPLIFIERS

to obtain quite large power output and good speaker response. Now slowly increase the frequency. Under normal operation the tubes are well loaded because the output transformer is so designed as to cause the speaker load to be reflected into the plate output circuit as optimum load impedance, and the load on the tubes should be fairly constant over a wide range of frequencies so long as the speaker efficiency does not vary greatly.

As the frequency is slowly increased, the signal voltage amplitude being held constant, the resonant frequency of the speaker is reached. At this point conditions change sharply. At resonance a much smaller amount of power will drive the speaker easily so that the effect is as though a large proportion of the load were suddenly removed from the plate circuit. With the load removed the reactive component of the plate impedance rises and the output voltage rises accordingly, tending to drive the speaker cone over still wider limits. This of course produces a booming in the speaker which ordinarily is resonant at a fairly low frequency.

When the inverse feed-back circuit is employed the effect is as follows: By means of R_1 , R_2 and C a portion of the plate voltage of each tube is fed back to the grid circuit of that tube and applied to the grid 180° out of phase with the original signal voltage. This of course decreases the effective grid excitation by a certain amount with a corresponding decrease in the power sensitivity of the tube and a requirement for greater excitation voltage for a given power output. When speaker resonance is reached and the plate voltage tends to rise sharply, the inverse voltage feed-back through R_1 , R_2 and C increases the proportion of degeneration voltage to original signal voltage so that the effective grid excitation is decreased to compensate for the tendency of the plate voltage to rise as the speaker load is decreased. Thus when the speaker *requires* less driving power for a given response, it actually *gets* less power, this of course tending to flatten out the speaker response curve and eliminating objectionable peaks at certain frequencies.

As explained in an earlier lesson (Lesson 48) inverse feed-back also provides a means of reducing hum, noise and distortion components which may originate in the amplifier stage or stages to which feed-back is applied. The importance of this to broadcast transmitters will be discussed later in this lesson.

AUDIO POWER AMPLIFIERS

The advantages and characteristics of inverse feed-back as applied to an audio power amplifier are:

1. The power output and efficiency of the tube are the same as without feed-back. This is because the actual gain and other operating characteristics of the tube are unchanged; the feed-back voltage simply combines with the original signal voltage at the grid to form a net voltage which is the algebraic sum of the two.

2. Distortion is decreased by the ratio of the input signal voltage with feed-back to the input signal voltage without feed-back. This is because the feed-back voltage containing all the harmonic components generated in the amplifier provides negative grid components to cancel the positive components appearing at the plate.

3. There is a considerable improvement in frequency response. This is due to the fact that feed-back tends to produce the effect of constant load impedance, compensating for Z_L variation due to poor frequency impedance characteristics of inadequate circuit components just as for other load variations. The frequency response is improved at both high and low frequencies.

4. Spurious frequencies generated in the tube and speaker combination by shock excitation and speaker resonance are minimized as explained in (3) above.

The principal use of inverse feed-back with a pentode or beam power amplifier tube is to improve the frequency response and to dampen the speaker at resonant peaks by lowering the effective impedance across the primary of the output transformer as explained above.

In the latter case, in order to design the feed-back circuit it is necessary to arbitrarily select the effective impedance which the tube is to represent across the output transformer primary. For example, the shunting impedance Z_p offered by the tube may be made equivalent to that of some low R_p triode which is known to operate satisfactorily with the specified speaker-transformer combination. Or, with a given speaker and step-down output transformer, Z_p may be made equal to the optimum matching impedance for the specified load and turns ratio.

$$\text{Turns Ratio} = T = \sqrt{Z_L/Z_s} \quad \text{where}$$

$$Z_L = \text{Plate load impedance}$$

$$Z_s = \text{Voice-coil impedance}$$

$$Z_L = T^2 Z_s$$

AUDIO POWER AMPLIFIERS

$$\text{Optimum } Z_p = Z_L$$

Assume that a Type 6L6 tube operated Class A delivers its output to an 8 ohm voice-coil through an output transformer having a step-down turns ratio of 23:1. Then the optimum primary terminating impedance would be,

$$Z_p = T^2 Z_s = 23^2 \times 8 = 4200 \text{ ohms (approximate).}$$

Reference Figure 18. Express the ratio of the voltage feed-back to the total output voltage by "K". It will be seen by inspection of the feed-back circuit that K also represents the ratio of R_1 to $(R_1 + R_2)$. Thus

$$K = \frac{R_1}{R_1 + R_2}$$

For high R_p tubes such as the pentode or beam power amplifier, K may also be expressed as,

$$K = \frac{1}{G_m \cdot Z_p} \text{ where } G_m = \text{Tube mutual conductance.}$$

The mutual conductance of a Type 6L6 with $E_b = 350$, $E_{sg} = 250$ and $E_c = -18$ is 5200 μmhos . Thus,

$$K = \frac{1}{5200 \times 10^{-6} \times 4200} = .045$$

Assume that $R_1 + R_2$ is arbitrarily chosen to be 100,000 ohms which would be a negligible shunt across $Z_L = 4200$ ohms. Then,

$$R_1 = K(R_1 + R_2) = .045 \times 100,000 = 4500 \text{ ohms.}$$

$$R_2 = 100,000 - 4500 = 95,500 \text{ ohms.}$$

With inverse feed-back it is necessary to increase the input signal to compensate for the effect of feed-back on the grid excitation.

$$\frac{e_f}{e_g} = 1 + K\mu_1 \text{ where}$$

e_f = input signal required with feed-back

e_g = input signal without feed-back

μ_1 = voltage amplification

AUDIO POWER AMPLIFIERS

To find μ_1 from the manufacturer's data for the 6L6 operated as explained above into $Z_L = 4200$ ohms and with $e_g = 18$ volts peak (driving the grid just to $E_g = 0$ volts), the power output is 10.8 watts.

$$P = E^2/R$$

$$E = \sqrt{PR} = \sqrt{10.8 \times 4200} = 213 \text{ volts (R.M.S.)}$$

$$E_{\text{peak}} = 1.41 \times 213 = 300 \text{ volts}$$

$$\text{Voltage Gain} = \mu_1 = E_p/E_g = 300/18 = 16.6$$

$$\frac{e_f}{e_g} = 1 + K\mu_1 = 1 + (.045 \times 16.6) = 1.75$$

In other words, with this amount of feed-back the input signal voltage would have to be increased to 1.75 times its value without feed-back for the same output. Expressing the feed-back in decibels,

$$\text{db} = 20 \log e_f/e_g = 20 \log 1.75 = 4.8 \text{ db.}$$

It should be noted that the latter figure expresses the degree of reduction by feed-back of noise and distortion--not a great deal when compared with the reduction of 20 to 40 db obtained in broadcast transmitters by overall feed-back extending over the entire audio amplifier system. (To be explained later in this lesson).

With the feed-back circuit constants of Figure 18, assuming other conditions of tube operation unchanged:

$$K = \frac{R_1}{R_1 + R_2} = \frac{10,000}{10,000 + 90,000} = .1$$

$$\frac{e_f}{e_g} = 1 + K\mu_1 = 1 + (.1 \times 16.6) = 2.66$$

$$\text{Feed-back (db)} = 20 \log 2.66 = 8.5 \text{ db}$$

This produces a substantially greater reduction in noise and distortion than with 4.8 db of feed-back but a correspondingly increased input signal voltage is required.

With the high power sensitivity and the corresponding comparatively low driver requirements of the beam power amplifier, the additional driver voltage requirement to make up for the decreased power sensitivity when using the inverse feed-back circuit is not at all serious. The tube power output and efficiency ratings are

AUDIO POWER AMPLIFIERS

not decreased and there is a substantial decrease in the percentage of harmonic distortion when using inverse feed-back and the larger driving voltage.

In the circuit with a large value of C so that the voltage drop across it is negligible, the plate voltage division for feed-back is proportionate to R_1 and R_2 . Thus to obtain greater inverse feed-back R_1 should be increased and R_2 decreased; for less feed-back, decrease R_1 and increase R_2 .

PARALLEL POWER AMPLIFIER TUBE OPERATION

It has been shown that whenever greater power output is required than can be obtained with a single tube operated Class A, two tubes are operated in push-pull. In fact, in any except the very inexpensive radio receivers, in all public address systems and in most studio monitoring equipment it is ordinarily considered good practice to operate the final stage push-pull in order to cancel out even harmonic distortion, even if the desired output could be obtained with a single larger tube. It sometimes happens however that more output is desired than can be obtained with two tubes of the type it is desired to use operated push-pull, and at the same time it is not desired to use larger tubes with the usual requirement of higher plate voltage. In that event, four instead of two tubes may be used, two tubes being connected in parallel on each side of the push-pull circuit.

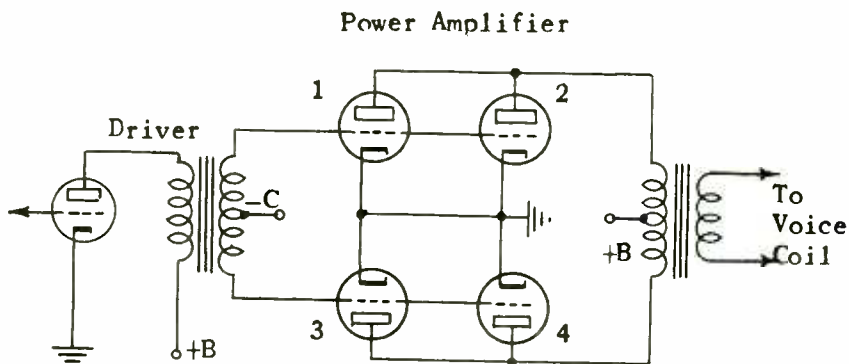

Fig. 19.

The arrangement is shown in Figure 19. Tubes 1 and 2 are connected in parallel so that they operate as a single tube on one side of the push-pull circuit. Tubes 3 and 4 are connected in

parallel on the other side of the circuit. The arrangement is simple and allows twice the power output that could be obtained with two tubes. However in the design or selection of circuit components, several factors must be carefully considered.

The grid bias voltage is exactly the same as in a two tube push-pull combination, but if it is obtained by means of an IR drop in which the power amplifier plate current represents I, then R must be just one-half as large as with two tubes. For example, if such an arrangement were used with the self-bias arrangement and calculations of Figure 6, R should be only $325/2 = 162.5$ ohms.

The plate voltage is the same as for two tubes.

The plate current is twice as great as for two tubes and the power supply must have adequate capacity to supply the increased load at the proper voltage. All transformer and reactor windings must be of sufficient size to safely carry the increased current.

The excitation and output voltages are the same as for a two tube push-pull circuit.

The tube plate impedance R_p of each side of the push-pull circuit is just *one-half as great* as in the two tube circuit.

So long as the excitation of the tubes is kept below the point where the grids swing positive, very little driving power is required for either the two tube or four tube combination. However if the tubes are to be driven beyond zero bias, the driver stage must be able to furnish considerable peak power in order that serious distortion is not introduced ahead of the power stage. When four tubes are used with such an operating condition, the input peak power required is just twice as great as for two tubes, and the driver stage must be designed with that in mind.

In that connection, the secondary of the input transformer must have low d.c. resistance if the power tube grids are to be driven positive, in order that an undesired fluctuating bias is not introduced by the IR drop in the input transformer secondary winding. This is very important whether two or four tubes are to be used, but the factor of resistance assumes increased importance in the four tube circuit due to the fact that the grid current peaks will be twice as great.

TUBE TO LOAD IMPEDANCE MATCHING

Correct impedance matching is an essential factor in design.

AUDIO POWER AMPLIFIERS

Assume that a two tube circuit is to be used employing two 6F6's operated Class AB triode connected with fixed bias. The effective load resistance (plate to plate) should be 6000 ohms. Assume that the effective speaker voice-coil impedance is 15 ohms. Then the turns ratio of the output transformer should be,

$$\text{Turns Ratio} = \sqrt{6000/15} = 20 \text{ (step down).}$$

Using the same tube types but employing four tubes as in Figure 19, the load impedance Z_L (plate to plate) should be only 3000 ohms. With the same speaker,

$$\text{Turns Ratio} = \sqrt{3000/15} = 14.1 \text{ (step down).}$$

Thus a load impedance only one-half as great as for two tubes in push-pull is required with the parallel combination; also an entirely different primary/secondary turns ratio is necessary to match the same voice-coil to the changed R_p conditions.

The importance of correct impedance matching between the amplifier tubes and the voice-coil is clearly shown in Table 1. Here is tabulated the *maximum undistorted output* obtained from a broadcast studio monitoring amplifier produced by one of the large manufacturers. The output stage of this amplifier consists of two triodes in push-pull and the load consists of the voice-coils of two dynamic reproducers connected in series. The measurements were made by connecting a variable resistance load across the output of the amplifier, setting the load resistance to the desired value, and then increasing the sinusoidal signal input until the distortion content in the output reached the allowed maximum of 5 per cent. At this point the voltage across the load was measured and the power output calculated from the equation, $P = E^2/R$.

With each load resistance, measurements were made at three frequencies, 400, 1000 and 5000 cycles per second. The outstanding disclosure of this group of measurements is the fact that *at only one value of load resistance (200 ohms) was the power output the same at all frequencies*. With this load resistance the undistorted power output was 2.9 watts at each of the three measured frequencies. At 100 ohms and 150 ohms greater 5000 cycle output was obtained but with less output at the two lower frequencies.

At the two lower frequencies the undistorted output drops off

AUDIO POWER AMPLIFIERS

TABLE I

Load Impedance In Ohms	Watts in Load at Frequency in Cycles/Second		
	400 c/s Watts	1000 c/s Watts	5000 c/s Watts
5	.25	.264	.65
10	.256	.324	.4
15	.35	.412	.486
20	.575	.575	.4
25	.52	.64	.7
30	.82	.83	1.2
35	.775	.93	1.22
40	.96	1.05	1.03
50	1.32	1.6	1.78
60	1.2	1.53	1.5
80	1.02	1.3	1.42
100	2.4	2.55	3.23
150	2.4	2.4	3.23
200	2.9	2.9	2.9
250	1.8	2.0	2.7
300	1.66	1.9	3.
500	1.05	1.05	1.68

sharply on both sides of the optimum load resistance. This indicates that when the output transformer and load impedance are properly designed to obtain *maximum undistorted output* at a lower intermediate frequency, the most uniform response over the intermediate and higher frequencies may be expected. The tabulated data also indicates that a mismatch of tube and load impedances *on either side of optimum* will result in a rising characteristic of power output vs frequency with the corresponding accentuation of the high frequencies and a loss of low frequencies. The reason for this is that when the load is not properly matched to the tube impedance, the plate output voltage is more a function of the reactance of the transformer primary which in turn is a direct function of frequency. When the transformer is properly designed to reflect the correct load resistance into the tube output circuit, the load into which

AUDIO POWER AMPLIFIERS

the tube operates tends to become resistive instead of reactive and is much less a function of frequency. Even with the low efficiency with which the average reproducer transfers electrical energy into mechanical energy, the effect of proper output transformer design on the fidelity of reproduction is quite pronounced and good impedance match is necessary if high fidelity reproduction is to be obtained.

The principles as outlined above of course apply at many points in the sequence of a broadcast signal proceeding from the microphone to the reproducer of a receiver. Wherever the signal energy is transferred from one device to another impedance matching becomes important. A few of these transfer points are: microphone to mixer, mixer to amplifier, amplifier to line, line to amplifier, amplifier to R.F. modulating amplifier, amplifier to reproducer, etc. It should be observed that it is of even greater importance to maintain proper impedance match in circuits carrying large amounts of power, as amplifier output circuits, than when the power level is low as in a dynamic microphone circuit.

CLASS B AUDIO AMPLIFIERS

The Class B audio amplifier is designed to permit maximum power output with high operating efficiency and a low percentage of harmonic distortion. High operating efficiency is obtained by biasing the tubes to, or almost to, plate current cut-off with zero excitation voltage; Class B operation with satisfactorily low harmonic distortion is a more difficult problem, the solution of which requires the most careful design. Even harmonic distortion is balanced out by the use of two matched tubes operating in a symmetrical back to back circuit. Minimizing of odd harmonic distortion requires other design precautions which will be discussed.

There are basic differences between Class AB and Class B amplifiers. The former operates substantially Class A on small excitation voltages and the principal distortion is introduced on large signal peaks. The Class B amplifier develops the greatest tendency toward distortion on small excitation voltages in which the grid swing is limited almost entirely to the region of the lower $E_g I_p$ curvature. Since the energy in the higher frequencies of speech and music is small, this results in a greater tendency to distort at these frequencies. The introduction of distortion at large excitation voltages is due mostly to the grid current characteristics.

AUDIO POWER AMPLIFIERS

Figure 20 illustrates curves of plate current and grid current vs. grid voltage for a typical amplifier tube which might be used in a medium power modulator circuit. Particularly note the dip in the I_g curve in the region of +30 to +60 volts. This is due to secondary emission from the grid and is one source of odd harmonic distortion with large signal voltage. The lower curvature of the $E_g I_p$ characteristic is the most difficult source of distortion to overcome at small excitation voltages because of the certain amount of non-uniformity of commercial tubes.

Class B audio amplifiers are used in broadcasting as modulators of R.F. power amplifiers. The modulated R.F. amplifier may be the

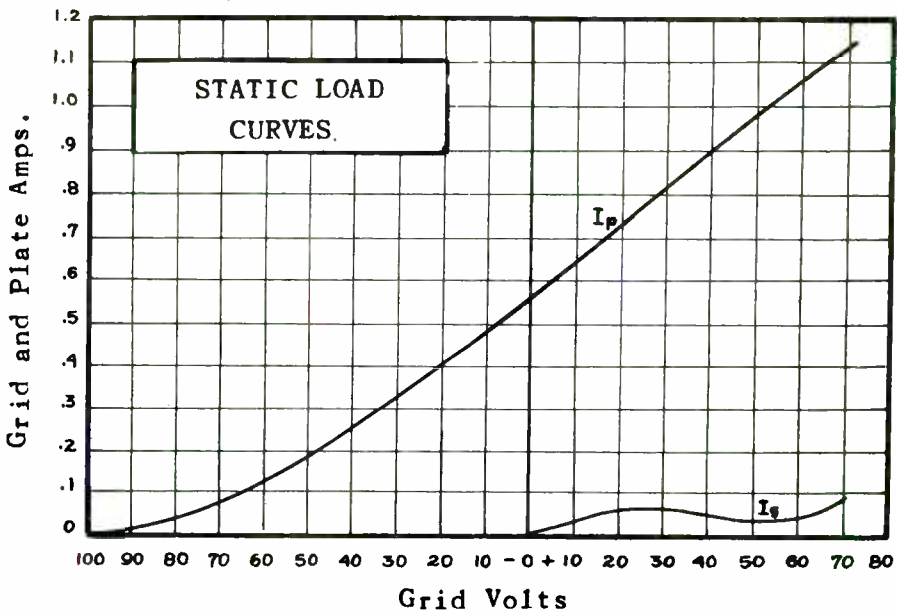

Fig. 20.

final power amplifier, as in the 1 K.W. and 5 K.W. transmitters of R.C.A., or it may be the intermediate power amplifier, as in the R.C.A. Model 50-D 50 K.W. broadcast transmitter in which the 5 K.W. modulated R.F. amplifier drives a 50 K.W. high efficiency power amplifier. The advantages and disadvantages of high level modulation of this type have been explained in preceding lessons.

The general theory of Class B audio amplifiers has been explained in earlier lessons (Lessons 33 and 46). At this point it is desired to discuss practical design considerations, methods used to minimize distortion, etc., with particular attention to the applica-

AUDIO POWER AMPLIFIERS

tions in modulator circuits. (For a quite thorough treatment of this subject the student is referred to "Distortion in Class B Audio Amplifiers" by True McLean, Proceedings of the Institute of Radio Engineers, March, 1936).

Figure 21 illustrates the desirable characteristics of a Class B amplifier tube. These characteristics are: substantially linear $E_g I_p$ and $E_g I_g$ curves, particularly in the small signal region, and zero grid bias I_p cut-off. Such characteristics are approached in special receiver type power amplifier tubes such as the Type 46 in which, due to very high μ , plate current at zero bias is quite small. With such a tube, the input impedance presents a continual load on the driver stage and there is not the sudden change from practically no-load to fairly heavy load as the grid excitation voltage passes the zero grid point from negative to positive.

Tubes having characteristics as shown in Figure 21 unfortunately are available at present only in sizes much too small to be useful as modulators in broadcast transmitters. Characteristics similar to those illustrated in Figure 22 ordinarily must be expected. These characteristics are not ideal in several respects: First,

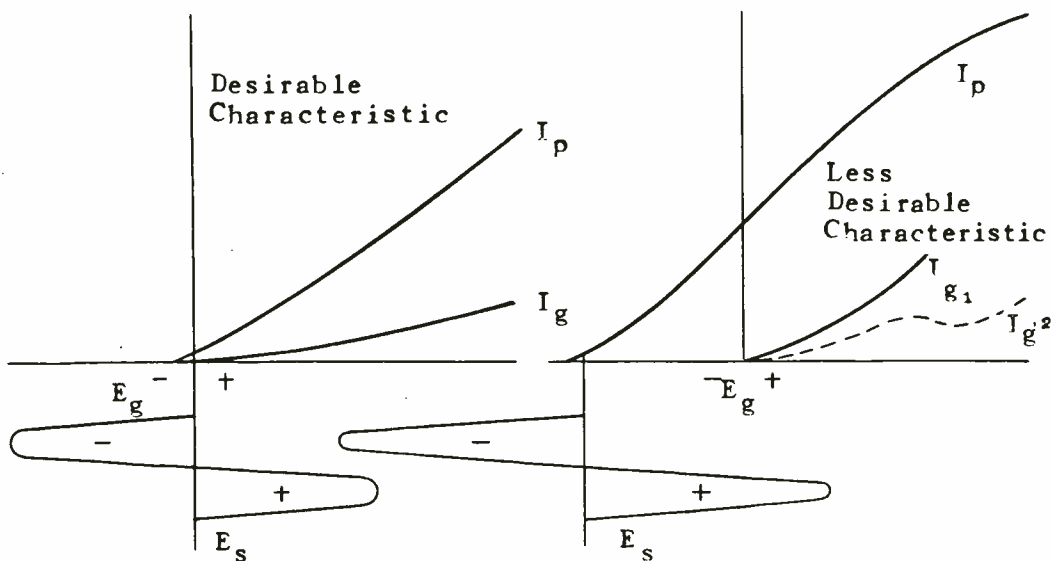

Fig. 21.

Fig. 22.

AUDIO POWER AMPLIFIERS

in the lower curvature which tends to introduce distortion at low modulation levels; this can be minimized by careful matching of tubes and by even more careful adjustment of individual tube bias voltages.

Second, the plate current cut-off occurs in a region of high negative bias which, however is less than the excitation voltage for modulation peaks; thus on modulation peaks there will be a sharp transition from the condition of zero grid current to grid current flow with accompanying sharp drop in the tube input resistance and corresponding change in the loading of the driver tubes. The distorting effects of this transition are minimized by employing driver tubes of *adequate power output* to make the increase in peak loading and the effects of the output impedance variation negligible, and by operating the driver tube into a quite high value of load impedance (Z_L).

Third, the $E_g I_g$ characteristic is far from linear. In the full curve (I_{g1}) the input impedance is not uniform, dropping quite rapidly with increase of positive excitation voltages. In the dotted curve (I_{g2}) the characteristics are better for small positive voltages but beyond a certain point, due to secondary emission from the grid, a dip occurs which may tend to cause dynatron oscillation. Such oscillation will introduce distortion of the high-order harmonic type that can be very annoying. The latter statement is particularly true since, due to the fact that most modulation peaks occur at the lower frequencies, high-order odd harmonics such as the seventh or ninth will fall within the desired audio range and will not be cancelled out by push-pull operation. This condition also must be minimized by the proper design of the input and driver circuits.

The ideal operating characteristics of a pair of special Class B tubes as outlined for the single tube in Figure 21 are illustrated in Figure 23. Here a pair of ideal Class B tubes operates with zero grid bias and with linear $E_g I_g$ characteristics. The tubes are so balanced that introduction of distortion due to lower curvature of the $E_g I_p$ characteristic is reduced to a very low level.

Assuming a linear $E_g I_g$ characteristic, the load on the driver is constant due to the constant Class B tube input impedance. On alternate alternations the load transfers smoothly from the input of one tube to the input of the other tube and the driver always works into a constant load impedance.

AUDIO POWER AMPLIFIERS

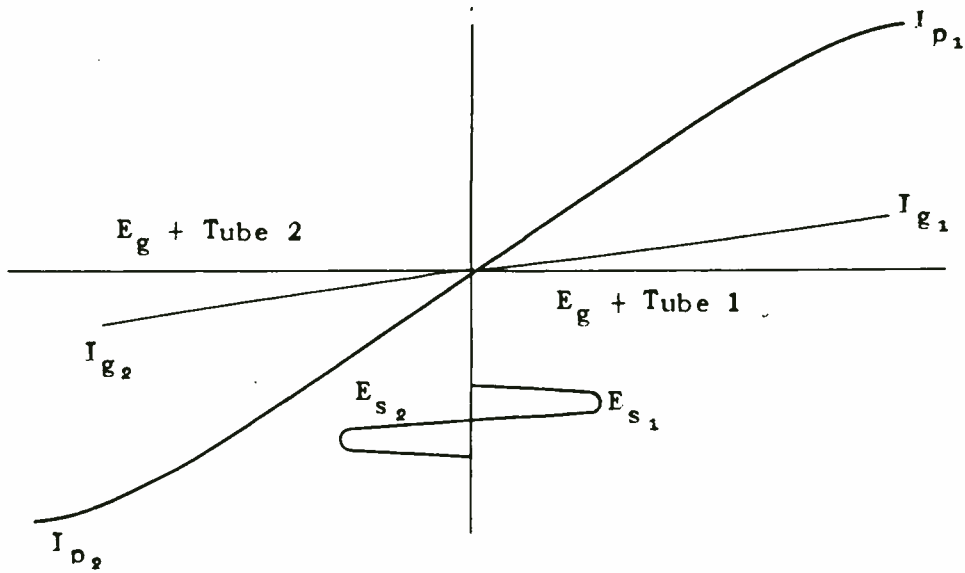

Fig. 23.

So long as the $E_g I_g$ characteristic is a straight line extending through the zero reference point, the input resistance as represented by $R_i = E_g / I_g$ is constant over the excitation cycle. Of course in no tube is a characteristic operating curve really linear. In the receiver tube Type 46 the $E_g I_g$ curve is substantially linear over most of the practical operating range. Careful measurements on the curve for such a tube indicate that for the range of E_g from +12 volts to +20 volts, I_g varies from 5 mils to 10 mils. In other words, E_g variation of 8 volts results in I_g variation of 5 milliamperes. Thus over this range $R_i = E_g / I_g = 8 / (5 \times 10^{-3}) = 1600$ ohms.

It should be understood that this value of R_i is an average value over the voltage range specified. In the range of lower voltage swings from zero, R_i may be calculated as high as 6000 ohms from similar measurements. Thus a number of measurements should be taken over the useful range of the curve and some compromise value selected.

Assume that it is desired to drive two Type 46 tubes operated Class B with one Type 46 operated Class A, and that the latter is to operate into $Z_L = 12,800$ ohms as recommended by the tube manufacturer for this combination. Assume further that $R_i = 2800$ ohms is the selected value of Class B input impedance which is a suitable compromise figure based on measurements. Since only one Class B power amplifier operates at a time, the input transformer turns

AUDIO POWER AMPLIFIERS

ratio is calculated from the entire primary to one-half the secondary.

$$\text{Turns Ratio} = \sqrt{Z_L/R_i} = \sqrt{12,800/2800} = 2.14 \text{ (step-down).}$$

Due to the fact that the $E_g I_g$ curve is not actually linear, the input impedance will not be the same for all ranges of excitation voltage and hence the load on the driver tube will not be constant. However with well designed tubes properly operated, there will be no abrupt change in the load impedance at any point and by proper selection of the transformer turns ratio, little distortion should be introduced by this factor.

One point in the tube manufacturer's recommendation is particularly important in this connection. The Type 46 tube operated Class A has plate resistance $R_p = 2380$ ohms. When used to drive a Class B stage it is recommended that Z_L be made approximately 12,800 ohms, more than five times R_p . With this value of Z_L the power output is considerably less than with optimum Z_L , but the power output is fairly constant over a quite wide variation of Z_L on either side of 12,800 ohms. Since, with a given transformer, Z_L is a function of R_i , this operating condition permits reasonable variation of R_i (as explained above, due to curvature of the $E_g I_g$ characteristic) without the introduction of serious distortion due to the fluctuating driver load. This same principle of course applies to the operation of any Class A stage driving a Class B audio amplifier.

In view of the fact that grid current flows in the input transformer secondary, it is desirable that this winding have very low resistance. The winding resistance should be negligible compared with the lowest input resistance of the tube.

Figure 24 illustrates the operating characteristics of two power tubes of the type which might be used in the modulator of a broadcast transmitter. Several marked differences exist between this and the characteristics illustrated in Figure 23. First, and probably most important, plate current cut-off occurs not at zero grid bias but with negative grid bias approximately equal to E_p/μ . Thus there will be a transition from the condition of no load on the driver to a definite load when the grid becomes positive, depending upon $R_i = E_g/I_g$ as explained above. This of course results in the power output of the driver varying due to the variation in

AUDIO POWER AMPLIFIERS

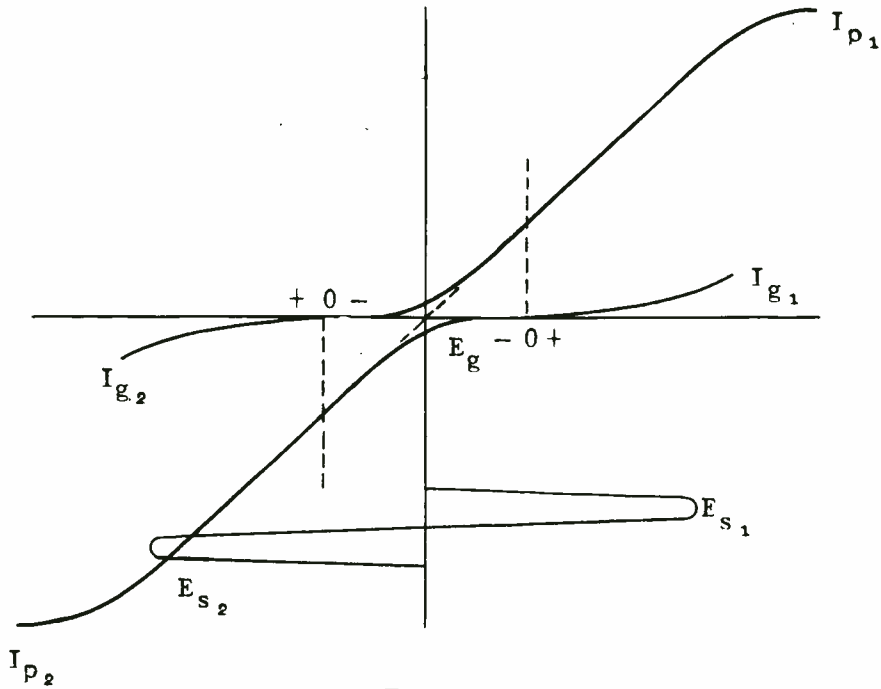

Fig. 24.

load impedance. To minimize this condition the transformer turns ratio should be selected to allow the driver to operate into sufficiently high Z_L that variation in Z_L due to fluctuating load causes minimum variation in power output. Further, the power output capacity of the driver tube should be sufficient to produce proper output voltage in spite of the losses introduced into the load circuit by the power amplifier input circuit.

With given power amplifier input resistance R_i , the higher the step-down turns ratio (T) the greater will be the load impedance (Z_L) into which the driver operates.

$$T = \sqrt{Z_L/R_i}$$

$$Z_L = T^2 R_i$$

Since it is desirable to have T large, and since the Class B power amplifier requires definite excitation voltage for full output, an increase in the step-down turns ratio (T) requires a corresponding increase in the output voltage of the driver. The driver transformer steps down the voltage in proportion to T but the driver load impedance is proportional to T^2 . Thus a comparatively large value of T is desirable for improved driver regulation and minimum distorting effect from varying load resistance. Within

AUDIO POWER AMPLIFIERS

limits of safe plate dissipation, peak undistorted output voltage is a function of the d.c. plate potential. Therefore it is desirable at the Class A driver to use the greatest safe plate voltage for the tube under consideration, keeping I_p within safe limits by increasing the negative grid bias, being careful however to keep the bias voltage at the center of the linear section of the $E_g I_p$ curve.

It has been stated that the input transformer secondary should have very low resistance in order that the IR drop in the winding when grid current flows will be negligible. If the transformer could be designed with zero leakage reactance, it would act simply as an impedance matching device between two resistances (driver Z_L and power amplifier input R_i) and R_i would appear to the driver plate as $Z_L = R_L$. However a transformer without leakage inductance is impossible so that in addition to the secondary IR drop there also is an IX_L drop which tends to introduce a distortion component. For any given transformer, leakage reactance varies directly as frequency because the leakage inductance is fixed, being a function of the transformer construction. At the very low frequencies its effects are negligible; at the very high frequencies it produces harmonics which are beyond the audible range. It is most troublesome for frequencies in the order of 1000 cycles, the harmonics of which appear as a faint high pitched hiss or scratch that rises and falls with the program level.

The effects of leakage reactance in the driver transformer can be eliminated by connecting a small capacity (C_1) of the proper value across the primary winding which, in conjunction with the leakage inductance (L_1), forms a half-section of a simple two element "constant K" type low-pass filter. By making the cut-off frequency of the filter about 1.5 times higher than the highest desired frequency, (say 15,000 cycles/second for a desired frequency of 10,000 cycles/second), the driver circuit can be made to have excellent frequency characteristics. The filter composed of the small capacity across the primary winding and the leakage inductance is terminated at one end by the driver tube plate resistance R_p . If L_1 and C_1 are so proportioned that the mid-shunt impedance of the filter (across C_1) is equal to the driver plate impedance (R_p), the same impedance (corrected for turns ratio) will be offered in the form of pure resistance to the grids of the power amplifier and there will be no reactive distortion introduced by the driver trans-

AUDIO POWER AMPLIFIERS

former. The arrangement of the circuit is shown in Figure 25. The built-out filter section is represented by C_1L_1 , L_1 being the leakage inductance of transformer T.

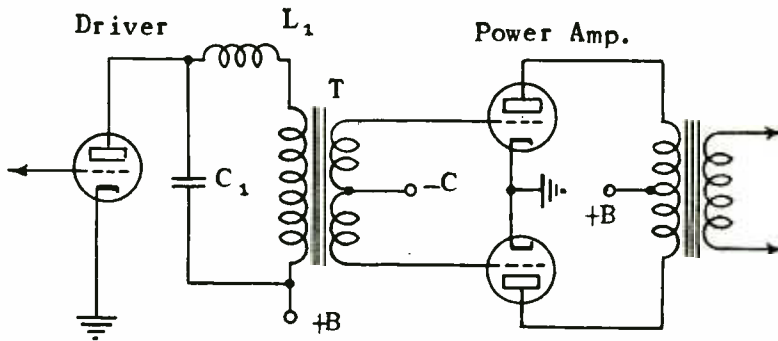

Fig. 25

Figure 26 illustrates the development of the "constant K" low-pass filter half-section referred to above. A "constant K" type low-pass filter is one in which the geometric mean of the series and shunt impedances is a constant for all frequencies which, for filter design purposes is equal to the resistance of the termination. See Figure 26 (a) and the actual filter in 26 (b). (In a high-pass filter the above definition would be true but the series arm would be capacitive and the shunt arms inductive).

The filter of 26 (a) and 26 (b) is called a π type filter.

The filter when properly designed and terminated has certain characteristics which can be made use of in circuit design, the actual operation of a low-pass filter being similar to that of a transmission line. First is the cut-off frequency (f_c) of the filter.

$$f_c = \frac{1}{\pi\sqrt{LC}}$$

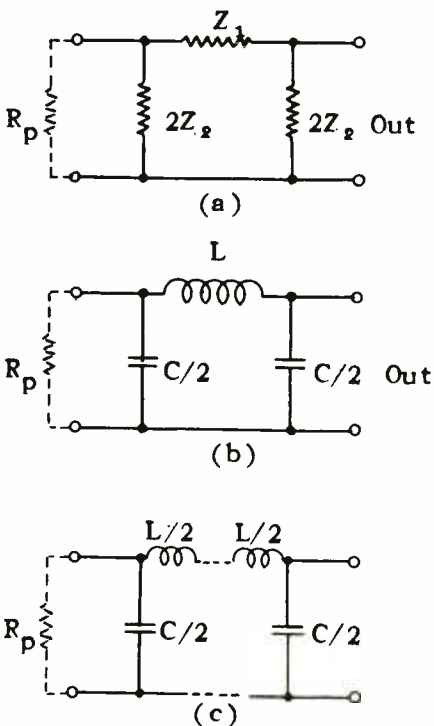

Fig. 26.

AUDIO POWER AMPLIFIERS

As shown in an earlier lesson dealing with power supply filters, the cut-off characteristic and attenuation at frequencies beyond f_c can be made as sharp as necessary by the use of several filter sections in series. For a filter of the type of Figure 26 the attenuation characteristics will be as in Figure 27.

The filter has a characteristic impedance (Z_0) which is fairly constant over the frequency range below f_c . $Z_0 = \sqrt{L/C}$ (approximately). When properly terminated there will be minimum reflection and the characteristic impedance will appear as resistance with negligible reactive component.

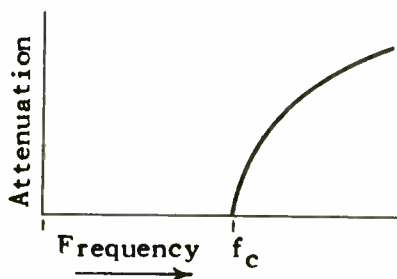

Fig. 27.

In the practical design of the "constant K" low-pass filter to be used between terminating resistances (R) two equations may be used, $L = R/\pi f_c$ and

$C = 1/(\pi f_c R)$. Consider a typical case where a Type 845 tube having $R_p = 1700$ ohms is to operate into a low-pass filter as in Figure 26 (b). It is desired that all frequencies be passed below 15,000 cycles/second and the filter is to be terminated by 1700 ohms.

$$L = R/\pi f_c = 1700/(3.14 \times 15,000) = .036 \text{ H.}$$

$$C = 1/\pi f_c R = 1/(3.14 \times 15,000 \times 1700) = 125 \times 10^{-10} \text{ F.}$$

$$Z_0 = \sqrt{L/C} = \sqrt{.036/(125 \times 10^{-10})} = 1700 \text{ ohms.}$$

$$f_c = 1/(\pi\sqrt{LC}) = 1/(3.14 \sqrt{.036 \times 125 \times 10^{-10}}) = 15,000 \text{ c/s}$$

Now in the circuit of Figure 25 the leakage inductance L_1 and the primary shunting capacity C_1 are to represent a half-section of a "constant K" filter. The division of the filter into two half-sections is shown in Figure 26 (c). If the driver tube of Figure 25 is a Type 845 to be operated under conditions as in the calculations immediately above,

$$C_1 = C/2 = (125 \times 10^{-10})/2 = 625 \times 10^{-11} \text{ F} = .00625 \text{ } \mu\text{F.}$$

$$L_1 = L/2 = .036/2 = .018 \text{ H.}$$

To compensate for the loss of high frequencies due to the shunting effect of C_1 across the transformer primary, the filter should be designed for f_c about 1.5 higher than the highest fre-

AUDIO POWER AMPLIFIERS

quency it is necessary to pass. Due to the fact that the value of C_1 is determined by the required upper frequency and the tube R_p , there is a definite upper limit on L_1 .

It has been stated that with this circuit the resistance appearing in the input (grid) circuit of the power amplifier is R_p corrected for transformer turns ratio. This is seen in Figure 25.

$$R_i = Z_L/T^2 \quad (\text{In this case } Z_L = R_p)$$

$$R_i = R_p/T^2$$

Assume that the peak output voltage from the 845 is 700 volts and that the required peak grid driving voltage for the following modulator (P.A.) tubes is 200 volts per tube. The step-down turns ratio (primary to one-half secondary) will be, $T = 700/200 = 3.5$. If $R_p = 1700$ ohms,

$$R_i = 1700/3.5^2 = 138 \text{ ohms.}$$

The input impedance will be R_i and, due to the built-out filter half-section there will be negligible reactive component. As stated above, it is desirable to make the driver plate voltage as high as practical and to use the greatest practical step-down turns ratio (T) in order to make the component $I_g R_i$ in the excitation voltage at the modulator grid as small as possible.

When the Class B audio amplifier is used as a modulator, it ordinarily is assumed that the R.F. modulated amplifier offers a uniform load to the modulator over the audio frequency band. That assumption is subject to error for two reasons: First, the output transformer has leakage inductance, the reactance of which is a function of frequency; second, an R.F. choke and by-pass condenser are connected between the plate of the modulated amplifier and the the modulator to keep the R.F. components out of the latter circuit, these units introducing a reactive component which varies with frequency.

Figure 28 illustrates a method used by one manufacturer to minimize the reactive effects mentioned above. Figure 28 (a) shows a circuit so arranged that by the addition of C_1 and L_2 , the transformer leakage reactance L_1 and R.F. by-pass condenser C_2 are included in a "constant K" π type filter connected between the modulator and modulated amplifier plates. The schematic filter circuit

AUDIO POWER AMPLIFIERS

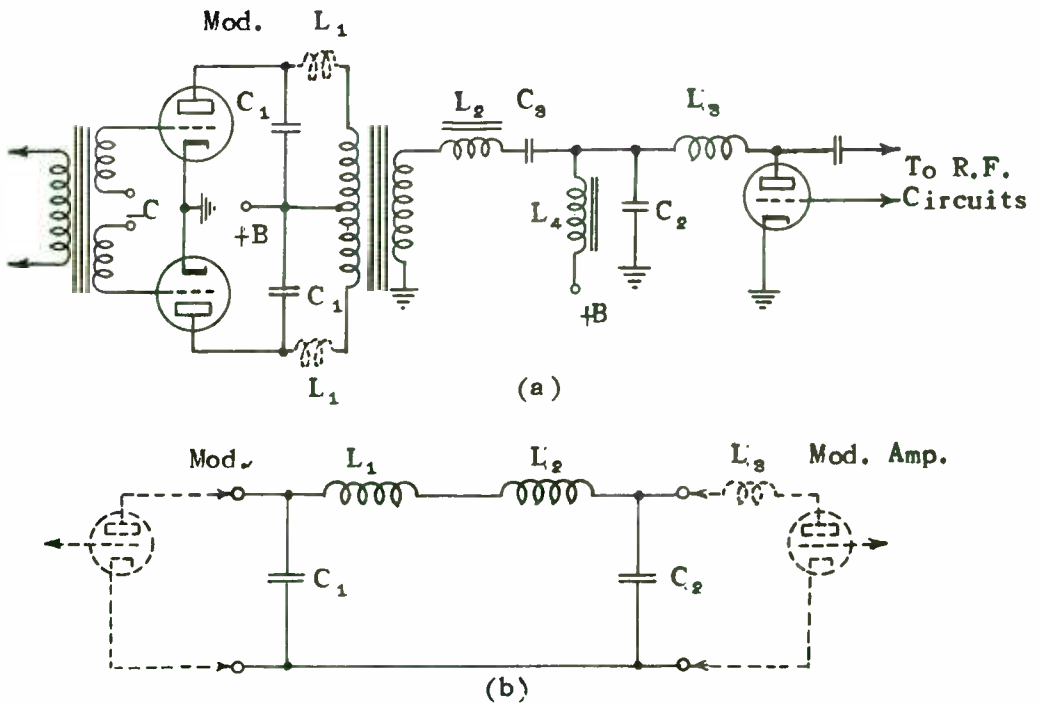

Fig. 28.

is shown in Figure 28 (b). Capacities C_1 are connected across the two halves of the primary of the output transformer. (It will be remembered that in a Class B audio amplifier only one-half of the output transformer primary winding is effective at any instant, the load shifting from one to the other each alternation). L_2 is a small reactor connected in series with the leakage inductance L_1 to form the desired total inductance for the series filter arm. C_2 forms the second filter shunt arm. L_3 is the R.F. choke which in this case has sufficiently low inductance to be negligible compared with the other filter elements. L_4 is a large reactor used to supply direct current to the modulated amplifier so that it will not have to flow through the transformer secondary winding. The capacity across L_4 is rather large and must be considered in the calculation for C_2 because it will be in parallel with C_2 . C_3 is a blocking condenser to keep direct current from the transformer secondary.

The transformer turns ratio is selected to provide the desired impedance load (Z_L) to the modulator tubes. The π network is terminated at the modulated amplifier end by a pure resistance equal

AUDIO POWER AMPLIFIERS

to the d.c. plate voltage (E_b) divided by the d.c. plate current (I_b). There will be some increase in the modulator load impedance Z_L at the higher frequencies because the power output level at these frequencies in speech and music is quite low and the plate resistance (R_p) of a Class B amplifier tube is not constant, rising as the output level decreases. This effect is not serious.

The use of a low-pass filter in the modulator output has another important advantage. In spite of the efforts taken to minimize high order harmonic distortion, some distortion of this type must be expected. If the generated harmonics are beyond the audible range, very annoying sideband interference may be created in adjacent channels. The use of a low-pass filter in the plate circuit of the modulator insures suppression of this type of interference.

The selection of the proper negative bias for a Class B audio amplifier is shown in Figure 24 by the dotted extensions of the characteristic curves which pass through the operating point. (Also see Figure 29). For a given plate voltage, as the negative grid bias is increased, the lower bend of the characteristic curve is entered, the effective μ drops due to the increase in R_p , and actual plate current cut-off is not reached when $E_g = E_p/\mu$. The correct operating bias for given plate voltage is found by projecting the straight portion of the $E_g I_p$ characteristic until it intersects the E_g axis. This is shown for three different values of plate voltage (E_b) in Figure 29. E_{b3} represents higher plate voltage than E_{b1} and E_{b2} and E_{g3} represents a greater negative bias voltage than E_{g1} and E_{g2} .

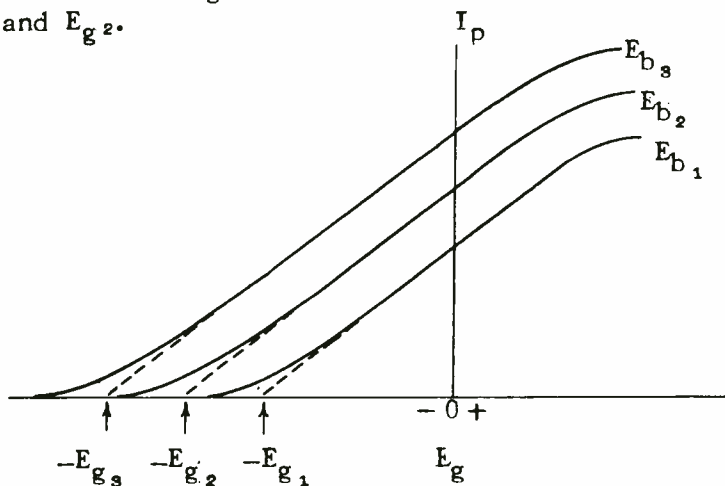

Fig. 29.

AUDIO POWER AMPLIFIERS

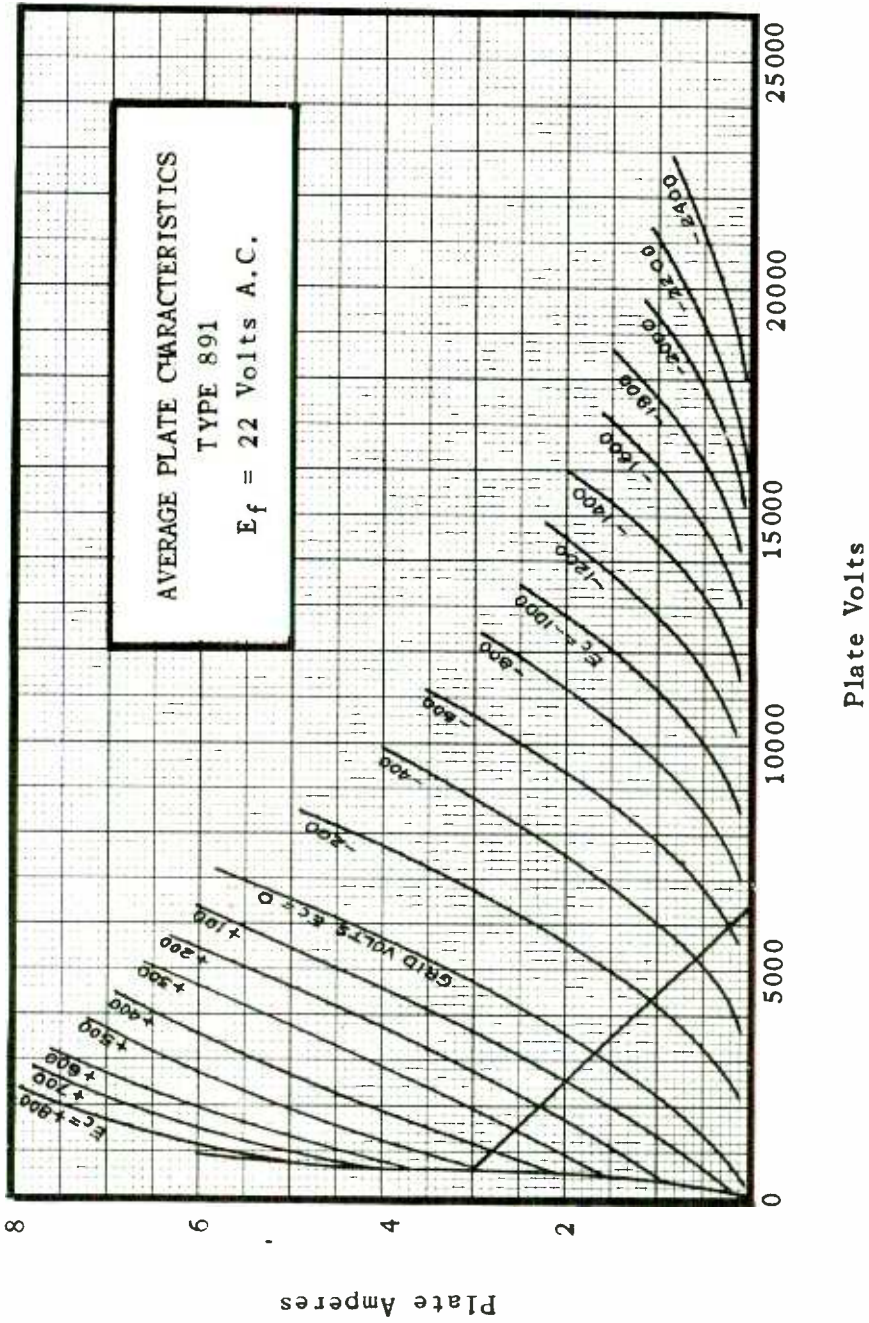

Fig. 30.

AUDIO POWER AMPLIFIERS

Figure 30 illustrates a family of $E_p I_p$ curves for a Type 891 power amplifier tube commonly used as a high level Class B modulator. Assume that two tubes are to be operated in a Class B modulator with $E_b = 6000$ volts, $E_g = -600$ volts, peak grid voltage swing per tube 1000 volts, and peak plate current 2.7 amperes. To find the proper load resistance (R_L) from plate to plate, the power output from the two tubes, and the plate efficiency.

First draw in the load line between the points ($E_b = 6000$, $E_g = -600$) and ($E_g = +400$, $I_p = 2.7$). $E_g = +400$ is derived from the stated bias of -600 volts and the peak grid voltage swing of 1000 volts. The load line crosses the ($E_g = +400$, $I_p = 2.7$) at $E_p = 1000$ so that this is the minimum plate voltage reached during the cycle. First to find R_L (plate to plate load resistance).

$$R_L = \frac{4(E_b - E_{\min})}{I_{\max}} = \frac{4(6000 - 1000)}{2.7} = 7400 \text{ ohms.}$$

Next, determine the power output from the two tubes when fully excited (2000 volts peak, grid to grid) and with plate to plate $R_L = 7400$ ohms.

$$P_o = \frac{I_{\max}(E_b - E_{\min})}{2} = \frac{2.7(6000 - 1000)}{2} = 6750 \text{ watts.}$$

$$\text{Plate Efficiency} = \frac{\pi}{4} \left[1 - \frac{E_{\min}}{E_b} \right] = \frac{3.14}{4} \left[1 - \frac{1000}{6000} \right] = 65.5 \text{ percent.}$$

It was shown in an earlier lesson that the maximum plate efficiency of a Class B amplifier is 78.5 percent ($\pi/4$) which is reached when the plate voltage is driven to zero. The curves of Figure 30 clearly show the impracticability of attempting to drive E_p to zero.

A major factor in the satisfactory operation of a large Class B audio amplifier is an adequate power supply. The factors are considerably different from those involved in an R.F. linear amplifier. In the R.F. amplifier a normal drain on the filter exists at the carrier level and modulation simply varies the output symmetrically above and below the carrier. There is of course, a rise in output with modulation but only as an average small percentage of the normal load. In the case of the audio amplifier the normal drain on the power supply is almost zero and the load rises to high

AUDIO POWER AMPLIFIERS

levels over appreciable periods of time, then falls off again, etc. Unless the power supply design has been quite generous this will result in poor regulation which of course tends to flatten the audio peaks and introduce distortion. This is minimized by the use of low resistance windings in the power supply transformer and reactors and by the use of filter capacity adequate to carry the cycle peaks.

INVERSE FEED-BACK APPLICATIONS

One application of inverse or degenerative feed-back was explained in connection with the operation of the beam power amplifier tube. It was shown that by feeding back energy from the plate to grid circuit in degenerative polarity and making suitable increase in the excitation voltage, the effect of speaker resonance could be counteracted.

In broadcasting, however, the principle of inverse feed-back has a far more important application in the reduction of hum, noise, and distortion components introduced by the audio amplifiers and modulator and by the R.F. power amplifier. The basic theory of inverse feed-back is discussed in Lesson 48. The methods of applying this principle will now be considered.

There are two general methods of obtaining the feed-back voltage to apply to the input of the transmitter audio amplifier. First, a suitable voltage component can be taken, usually by means of a capacity potentiometer, from the final R.F. amplifier tank circuit or input to the transmission line, rectified, and the audio component applied *in proper phase and amplitude* to the input of the audio amplifier. This method is shown schematically in Figure 31.

The R.F. power amplifier tank circuit L_1C_3 is loaded by the transmission line and antenna termination. Across the tank capacity (C_3) is connected a capacity potentiometer C_1C_2 . The feed-back component is taken from across C_1 which is so proportioned with respect to C_2 that the output voltage of the R.F. power amplifier is divided up to provide the desired signal level for feed-back rectifier operation. This R.F. component is applied across the feed-back rectifier which delivers the audio frequency component to the resistance network R_1R_2 .

The feed-back transmission line connects above R_2 , the other end of the line terminating in R_3 through a low-pass filter LC. The filter is designed to pass only the desired band of audio fre-

AUDIO POWER AMPLIFIERS

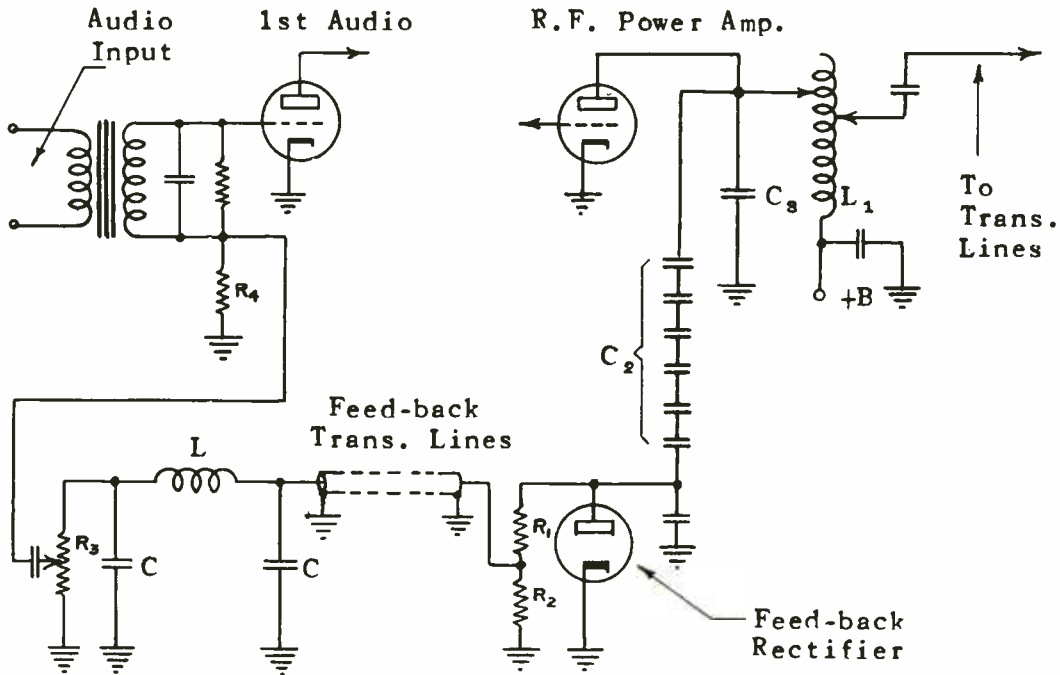

Fig. 31.

quencies while suppressing all radio frequency components which otherwise might enter the audio frequency amplifier and cause unstable operation. R_3 is the feed-back control potentiometer which permits adjustment of the amplitude of the inverse voltage applied across R_4 to the input of the audio amplifier.

This is a preferred system of feed-back because the audio frequency component derived from the modulated radio frequency output of the final power amplifier contains all the hum and distortion components generated in the entire transmitter--both R.F. and A.F. circuits--and permits the feed-back circuit to minimize all of these undesired components. On the other hand, the use of this system requires very careful design and adjustment of all parts of the transmitter handling audio frequencies, or audio frequency components of the R.F. signal, to avoid excessive phase shift at any frequency.

In conventional audio frequency amplifier design the factor of phase shift is not of great importance because the ear is not sensitive to phase shift variations. In the feed-back circuit this factor is of particular importance. Here a signal is deliberately fed back from the output to the input circuit, desirably with 180° phase relation in respect to the input signal voltage.

AUDIO POWER AMPLIFIERS

Amplifier phase shift is introduced by reactive circuit components which produce a *time delay* or retarding effect. A time delay represents a phase shift because time expressed in a fraction of a second may be represented by an appropriate number of electrical degrees. Unfortunately the phase shift due to reactive components in a conventional amplifier is not constant over the required frequency band. If it were, it easily could be compensated for. Actually the *time delay* introduced by any reactive component is substantially constant, which means that the phase shift varies as a function of frequency.

In most conventional amplifier design the phase shift at the lower audio frequencies is negligible, increasing however with an increase of frequency. If a frequency is reached at which the undesired phase shift becomes as high as 180° , the energy fed back at that, and higher frequencies, will be *regenerative* instead of *degenerative*, and the amplifier will become unstable, tending to break into high frequency oscillation or "singing". This is probably the most common source of trouble when it is attempted to apply feed-back to an older transmitter in which the factor of phase shift was not considered in design. If such difficulty is encountered it will be necessary either to redesign the audio system of the transmitter or else apply a corrective network in the audio amplifier to compensate for the undesired phase shift, the actual compensation of course, depending upon the type of audio system used and the magnitude of correction required. It must be remembered that the phase shifts in a multistage amplifier are accumulative, the total being the sum of the phase shifts in the individual stages.

High frequency phase shift in a resistance coupled amplifier is caused by distributed shunt capacity and is most noticeable when the values of plate and grid resistance are large. By keeping these resistances reasonably small the phase shift within the audio frequency band can be kept within proper limits.

High frequency phase shift in a transformer coupled amplifier is due primarily to the transformer leakage inductance and is more difficult to overcome. Where a step-up transformer is used in which the leakage inductance combined with the distributed capacity of the secondary winding forms a series resonant circuit at some high audio frequency, the correction problem becomes complex. Even though the resonant frequency is beyond the desired frequency band

AUDIO POWER AMPLIFIERS

to be transmitted, appreciable phase shift occurs at substantially lower frequencies. If this condition is encountered, probably the only satisfactory solution will be to replace the transformer with one having more desirable characteristics (less leakage inductance and distributed secondary capacity) or by converting the amplifier stage to resistance coupling.

In the case of serious phase shift encountered in the output circuit of a Class B modulator, or in its driver circuit, the logical solution is to build out either or both into a low-pass filter as explained earlier in this lesson. In such a circuit the phase shift is negligible over the band passed and the effect of leakage reactance is completely compensated.

The number of audio stages employed, and whether resistance or transformer coupling or a combination of both are used, are important factors in the design of a feed-back circuit. The actual number of phase reversals caused by amplifier tubes and transformers must be determined carefully so that the voltage fed back is in degenerative polarity.

Also important is the increase of input signal required to compensate for the fundamental frequency component of the feed-back signal. Ordinarily in applying feed-back to an existing transmitter, it will be necessary to add one stage of audio amplification to bring the overall gain back to normal.

A second method of applying feed-back is shown in Figure 32. This is the circuit used in the R.C.A. 1 K.W. broadcast transmitter Type 1-K and is similar to that used in the R.C.A. 5 K.W. transmitter Type 5-D. In both of these transmitters high level plate modulation is employed and the modulator load is the final R.F. power amplifier which is being modulated; thus any audio distortion present in the R.F. modulation component is also present in the output of the modulator. Therefore overall feed-back is obtained by utilizing a component of the modulator audio output for application in inverse phase to the amplifier input.

The entire amplifier from first stage to modulator, inclusive, is pushpull. Feed-back voltages are obtained from the compensated RC network across the primary of the modulator output transformer T_3 . This network consists of $R_3R_4R_5R_6C_1C_2C_3C_4$ and is designed to compensate for inductive components present in the transformer coupling, at the same time being so proportioned as to divide the

AUDIO POWER AMPLIFIERS

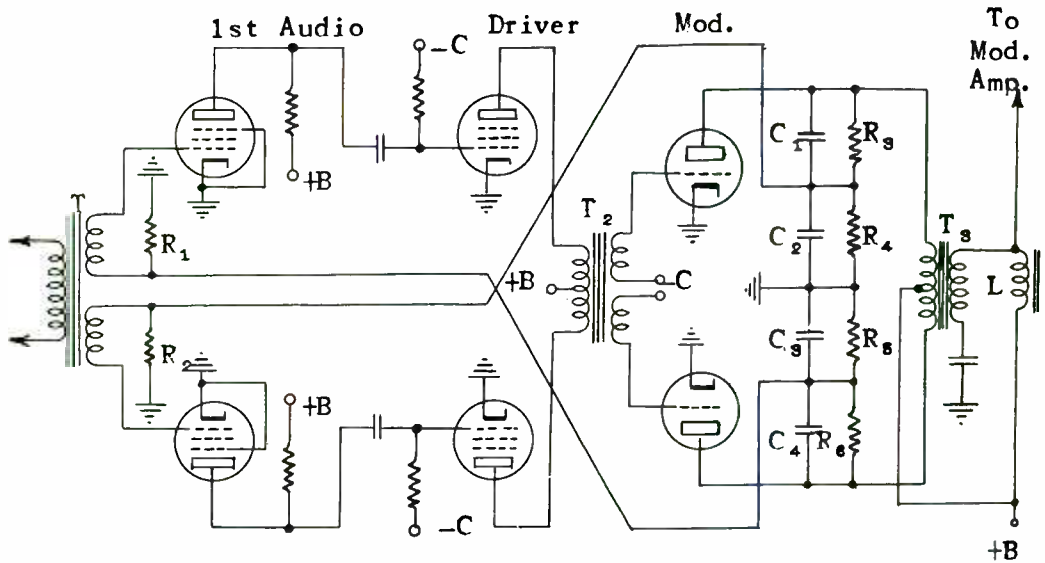

Fig. 32.

output voltage to provide the desired feed-back. Feed-back voltages of inverse polarity are introduced at the input of the first amplifier stage across R_1 and R_2 . T_2 is a special driver transformer designed to operate with minimum phase shift in the audio frequency band; that is, it is designed to have small leakage inductance and small secondary winding capacity.

The first amplifier stage employs pentodes Type 1620, resistance coupled to the driver stage which consists of beam power amplifier tubes Type 828, which in turn drive two Type 833-A triodes which operate Class B, modulating two similar tubes in the modulated amplifier.

In the circuit of Figure 32, the amount of feed-back is controlled by the ratio of the resistors $R_4:R_3$ and $R_6:R_5$. That is, these resistors simply form two voltage dividers which permit any desired proportion of the output voltage (the proportion of course will always be small) to be fed back to the amplifier input as shown.

The amount of feed-back employed is determined by two factors: First, the desired reduction in the noise and harmonic components; second, the amount of feed-back that can be used without the amplifier becoming unstable. These factors are opposing. The greater the amount of feed-back employed, the greater will be the reduction

AUDIO POWER AMPLIFIERS

of noise and distortion. On the other hand, if excessive feed-back is used, there usually will be found some high frequencies at which adequate reduction of phase shift is not feasible and the amplifier will tend to oscillate.

It has been shown that the input signal to the amplifier with feed-back must be increased by the amount of feed-back voltage in order to maintain the amplifier output voltage with feed-back equal to the output without feed-back. *The ratio of the input signal voltage with feed-back to the input signal voltage without feed-back is equal to the ratio of the per cent distortion voltage without feed-back to the per cent distortion voltage with feed-back.* This ratio is taken as the measure of feed-back and usually is expressed in decibels.

$$\text{db} = 20 \log \frac{E_1}{E_2}$$

E_1 = input signal voltage with feed-back.

E_2 = input signal voltage without feed-back.

For example, assume that measurements made without feed-back indicate at 100 per cent modulation and 400 cycles/second, audio distortion of 15 per cent in the transmitter output and that it is desired to reduce this to .5 per cent. How much feed-back will be required and how much must the input signal voltage be increased to provide 100 per cent modulation?

$$\begin{aligned} \text{Required feed-back} = \text{db} &= 20 \log \frac{E_1}{E_2} \\ &= 20 \log \frac{\text{distortion without feed-back}}{\text{distortion with feed-back}} \\ &= 20 \log \frac{15}{.5} = 20 \log 30 = 20 \times 1.48 \\ &= 29.6 \text{ db.} \end{aligned}$$

In this case 30 db of feed-back would be employed. With the input gain control calibrated in decibels, without feed-back apply 400 cycle signal voltage to the amplifier input and adjust the level until the transmitter is modulated 100 per cent as indicated by the modulation meter. Then introduce feed-back, first at a moderately low level and increase the input signal voltage to

AUDIO POWER AMPLIFIERS

maintain full modulation. Gradually increase both feed-back and input signal until about 15 db of feed-back is applied. Then vary the input signal frequency over the entire audio frequency band, watching particularly for any sign of instability. Gradually increase feed-back and input signal level, carefully checking the entire audio range with each increase, until the desired 30 db of feed-back is being used. This will be indicated when, by means of the input gain control, the input signal level at 400 cycles/second has been increased 30 db and the transmitter is modulated 100 per cent.

If at any point in the above procedure the amplifier tends to become unstable at any frequency, it will be necessary to apply proper corrective treatment before further increasing feed-back. If feed-back is being applied to a transmitter not originally designed for feed-back, the necessary corrective treatment may be a major redesign of the entire audio system. When the amplifier design is basically correct, only minor corrective treatment should be required to compensate for reactive components which become troublesome at some particular frequency. These reactive components will be leakage inductance and distributed capacities. The principal feature in amplifier design, so far as feed-back is concerned, is to keep the reactive components to a negligible value by proper selection of circuit and circuit components, or by compensating measures if satisfactory circuit components are not available.

AUDIO POWER AMPLIFIERS

EXAMINATION

1. A Type 2A3 triode is to be operated Class A as follows: $E_b = 250$ volts, $E_c = 30$ volts r.m.s., $\mu = 4.2$, $R_p = 800$ ohms, $Z_L = 2500$ ohms. What is the power output?
2. For the 2A3 operated as in Question 1, E_b varies between 360 volts and 110 volts. Find E_1 as shown in text. Calculate the correct grid bias voltage.
3. For the 2A3 operated Class A with bias of -40 volts, $E_b = 250$ volts, what is the correct value of Z_L ? What is the maximum undistorted power output with these operating conditions?
4. The plate current of the 2A3 for $E_b = 250$ volts, $E_c = -40$ volts is 80 milliamperes. What is the plate operating efficiency under the conditions of Question 3 with maximum undistorted power output?
5. You wish to operate four Type 2A3 tubes Class AB with $E_b = 280$ volts, $E_c = -60$ volts, I_{b_0} per tube at zero signal is 25 milliamperes. With a self-bias circuit, what is the correct value of bias resistor?
6. You wish to operate the tube combination of Question 5 into a load impedance (plate to plate) of 2500 ohms. The load is actually the 8 ohm voice-coil of a reproducer. What transformer turns ratio would you use?
7. If, in the circuit of Questions 5 and 6 you decide to use only two tubes instead of four, what changes would you make?
8. (a) Explain why it is desirable to use inverse feed-back when driving a reproducer with beam power amplifier tubes. What is the function of the feed-back and how is it accomplished?

(b) Why is phase shift such an important factor when applying overall feed-back to a broadcast transmitter? What causes phase shift and how is it minimized? What is the effect of excessive phase shift? Explain.

AUDIO POWER AMPLIFIERS

EXAMINATION, Page 2.

9. (a) When the grid of either tube of a Class B audio amplifier is driven positive, its lowest input resistance, as determined by the calculation based on the $E_g I_g$ curve, is approximately 500 ohms. The driver tube feeding this stage has an R_p of 1225 ohms. On the basis that the driver tube should work into about $5 R_p$ for its load, what transformer turns ratio (primary to secondary) would you use?
- (b) What is the lowest value of the load impedance as seen by the driver tube at the primary terminals?
10. (a) What is the effect of leakage inductance in the coupling transformer between the driver and a Class B modulator and what will result if this factor is not minimized? Is the undesirable effect of transformer leakage inductance minimized by the distributed capacity of the secondary winding? Why? Explain
- (b) Explain the reasons for, the method, and three beneficial results of building-out the output circuit of a Class B high level modulator into a low-pass filter.

