



SECTION 2

**ADVANCED
PRACTICAL
RADIO ENGINEERING**

TECHNICAL ASSIGNMENT

TRIODE TUBES

Copyright 1950 by
Capitol Radio Engineering Institute
Washington, D. C.

226 E

- TABLE OF CONTENTS -

TRIODE TUBES

	Page
SCOPE OF ASSIGNMENT	1
OPERATION OF A TRIODE	1
SPACE CHARGE	1
EFFECT OF GRID	4
SECONDARY EMISSION	8
GRID CONSTRUCTION AND MOUNTING	9
EFFECTS OF GRID VOLTAGE VARIATIONS ON THE PLATE CURRENT	10
CURRENT SATURATION	11
GRAPHICAL CONSIDERATIONS	12
TUBE CHARACTERISTIC CURVES	12
CALCULATING TUBE CONSTANTS	19
TRIODE OF CONSTANTS	19
AMPLIFICATION FACTOR	20
PLATE RESISTANCE	21
GRID PLATE TRANSCONDUCTANCE	22
INTERELECTRODE CAPACITY	23
TUBE INPUT IMPEDANCE	23
RESUME'	25

TRIODE TUBES

SCOPE OF ASSIGNMENT

Up to this point the vacuum tube has been considered only on the basis of its operation as a two element tube. The effects of variations of plate and filament voltages have been shown. The two element tube is an excellent rectifier and may be used in circuits for either full or half-wave rectification.

However, in radio the use of a vacuum tube as a rectifier is one of its least important functions. The real usefulness of the tube manifests itself when a third element, the grid, is inserted. The three element tube makes radio communication commercially practical, in its various functions as detector, low and high-frequency amplifier, and as a converter of power from direct current to high or low frequency alternating current. The many uses of the three-element vacuum tube are well known, and the operation of the tube in its various functions will be discussed in detail in following assignments. The important point here is that the introduction of the grid into the tube marked the real beginning of the period of usefulness in the development of the vacuum tube.

OPERATION OF A TRIODE

SPACE CHARGE.—In studying the function of the grid it is first necessary to understand clearly the effects of the space charge. The space charge is a *negative charge* between the plate and cathode (cathode and emitter will be used

interchangeably in this discussion) of the tube, and is composed of the electrons in space between these two elements, the electrons having been emitted from the heated filament or cathode.

With normal filament temperature and normal plate voltage the cathode is emitting a large number of electrons per second, and some of these electrons are penetrating the space charge and going over to the plate, returning to the cathode through the external circuit. The emitted electrons that do not reach the plate expend their initial energy in trying to overcome the space charge and the attraction of the cathode and then fall back to the cathode. *Exactly as many electrons reach the cathode each instant as are emitted by the cathode.*

The effect of the space charge, since it is composed entirely of electrons, is wholly negative, and under normal conditions the positive plate voltage only counteracts a portion of the space charge around the cathode. If the positive field of the plate penetrated completely through the space charge all of the emitted electrons would go to the plate. That is the condition of saturation plate current in the tube. If the plate voltage penetrates only partly through the electron cloud, since the effects of this cloud are wholly negative, the space between the cathode and the point of deepest penetration of the plate voltage must be negative

Since the plate is highly positive with respect to the cathode, it is evident that positive potential must fall off as the distance from the plate increased, reaching

exactly zero at the point of deepest penetration into the electron cloud. The entire plate voltage is used in counteracting negative space charge effects between this point and the plate. *Between this point and the cathode the space is negative with respect to the cathode.*

The form in which the plate voltage falls off along the space between the plate and cathode depends upon several factors. If the resistance per millimeter of the space between the cathode and plate were uniform throughout the entire distance, the voltage would fall off in a straight line.

This can be demonstrated by a simple experiment with a piece of resistance wire connected across the terminals of a battery. If the resistance per inch of the wire is uniform throughout, and a voltmeter, one terminal of which is connected to a variable slider, is used to measure the voltage between the negative or zero end of the circuit and various points along the resistance wire, the voltage will be seen to drop off in a straight line between the positive and negative ends of the circuit. This is shown in Fig. 1. In accordance with Ohm's Law the voltage drop along a series circuit varies directly as the resistance. Applying this to a vacuum tube, if the resistance of the space between the plate and cathode is uniform the voltage drop between the plate and cathode will be in a straight line.

The resistance of any substance is governed by the number of free electrons per cubic unit of the substance. Therefore to have a uniform resistance it will be necessary to have uniform electron distribution throughout the space between the

cathode and plate. *Such a condition could exist only between two parallel electrodes of identical shape and area, one emitting electrons as a cathode and the other acting as a plate, and all electrons emitted going to the plate.* The average number of electrons per cubic unit of space should be uniform between such an arrangement of plate and cathode.

This condition assumes, first, that the emission is the same from all parts of the emitting surface; second, that the areas of the plate and cathode are identical; and third that the path of the electron between the cathode and the plate is a straight line. The third condi-

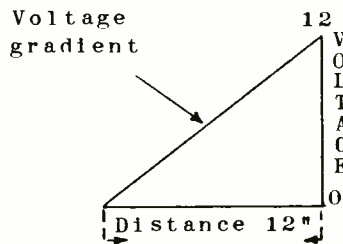
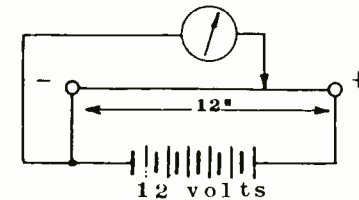

Fig. 1.—Potential Variation with distance along a uniform wire (resistor).

tion can be practically satisfied but in practice the emitting surface of the cathode is many times smaller than the attracting area of the plate.

A typical condition is shown in Fig. 2. To illustrate, assume an emission of eight electrons from the cathode at a given instant, these electrons all proceeding in straight

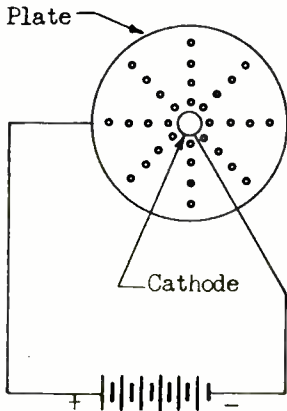

Fig. 2.—Path of electrons from cathode to plate.

lines to the plate. At the cathode the eight electrons will be very close together, as the electrons get nearer the plate, the distance between electrons becomes greater, and the closer the electrons get to the plate the greater the separation of the electrons. This is because the area of the plate is so much larger than the emitting area of the cathode. If the electrons are separated farther in the space near the plate than near the emitter, then the electrons per cubic unit of space must be greater near the emitter and fewer near the plate.

The resistance of any conducting space varies inversely as the number of free electrons per cubic unit of that space, the resistance being highest where the free electrons are least plentiful. Therefore the resistance of the space between the plate and cathode must be

high at the plate and low approaching the emitter where the electrons are very plentiful.

According to Ohm's Law, the potential drop varies directly as the resistance, therefore the drop in potential must be high at the plate, falling off less rapidly as it approaches the cathode. With a circular emitter and a circular plate, the VARIATION in space resistance will be fairly uniform and the potential drop will be very rapid close to the plate due to the high resistance of the space at that point. As the cathode is approached the potential drop becomes more and more gradual.

In Fig. 3. are shown two possible potential distributions. If

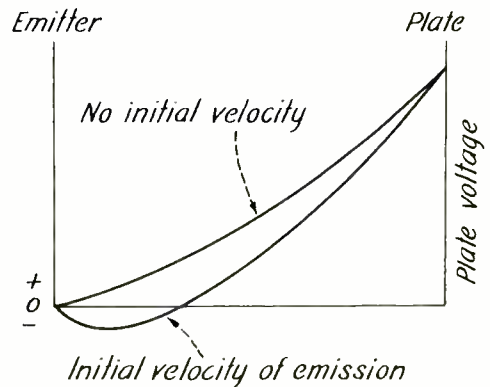

Fig. 3.—Potential distribution in a 2-element tube with and without initial velocity of emission of the electrons.

the electrons come out on the cathode surface without any initial velocity of emission, then the potential gradient rises steadily as one proceeds from cathode to the plate.

If, on the other hand, the

electrons have an initial velocity of emission (as is normally the case) then they surge out in such numbers as to form an excess close to the cathode surface, and this excess tends to repel other electrons back to the cathode. Therefore the potential gradient goes negative in this region as a result of this repelling effect. Of course, the repulsion cannot exceed in effect that which produced it, namely the initial velocity of emission; it cannot prevent further electrons from coming over to this inter-electrode region as fast as electrons leave to proceed to the plate.

EFFECT OF GRID.—By placing a third element, the grid, between the plate and cathode, it is possible to further vary the shape of the potential drop curve from plate to cathode.

If the grid is insulated from all other electrodes ('free' grid) then it will assume the potential of that part of interelectrode space. For example, if the potential gradient of a diode is shown in Fig. 4 by curve a, and the grid is placed at a certain point between the

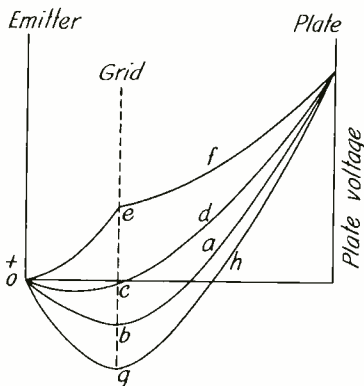

Fig. 4.—Effect of grid on potential gradient in a vacuum tube.

cathode and plate, as shown, then it will assume the potential at point b along the curve.

If the grid is tied to the cathode by a negligible resistance connection, so that it has essentially the same potential as the cathode ('Zero' grid), it will raise the potential gradient curve from b to c on the axis, giving rise to a new curve cd.

If the grid is made positive, point c rises to point e, and curve ef is obtained. If the grid is made more negative than when in the 'free' condition, point b drops to point g, and curve gh is obtained.

If, however, a positive charge is placed on the grid the effects are very noticeable. Any positive charge in the vicinity of the electron cloud will counteract a certain amount of the space charge, the effect of which is negative. Since the space charge is responsible for the contraction of the electron cloud close to the emitter, if the effect of the space charge is partially overcome, the initial velocities of the electrons will carry them a greater distance from the emitter and the entire electron cloud will spread out. This means that a greater number of electrons will reach out far enough to come under the influence of the positive charge of the plate and consequently more electrons will reach the plate. This will result in a greater plate current for the same plate voltage and consequently a decreased plate to cathode resistance in the tube. This effect has been clearly demonstrated in the study of the mercury vapor rectifier tube where a counteracting charge of positive ions is used to decrease the effective space charge. The effect of the positive

grid is exactly the same, the difference being that the positive charge is held on the grid wires instead of on slowly moving gas ions.

It should be observed that the increased electron flow to the plate and the spreading out of the electron cloud will cause a tendency toward a more uniform electron distribution between plate and cathode. This will tend to straighten out the potential drop curve between the plate and cathode which, due to the unequal areas of the cathode and plate, can never become a straight line; but the curvature can be made more gradual than the curvature when the effect of the positive grid is not present.

Curve *ef* in Fig. 4 shows a pronounced 'hump' at the point occupied by the grid. This is due to the fact that the total voltage of that point with respect to the cathode is equal to the sum of the plate voltage component at that point plus the positive voltage of the grid. It should be noted that the actual voltage at any point in space with respect to the cathode is higher than was the case with the zero grid. This is due, first, to the additive effects of the positive grid charge, and second, to the more gradual curvature of the voltage drop as previously explained.

The grid being positive also attracts electrons, and if a milliammeter is connected between the grid and cathode, grid current will be observed to flow. The action of the grid in taking current is identical to that of the plate. The construction of the grid, however, precludes its absorption of the entire electron cloud unless the grid voltage is made excessively high. The grid is made up of fine

wire with the spaces between the grid wires considerably greater than the actual space occupied by the wire itself.

Thus when an electron leaves the cathode at high velocity, if its path takes it straight toward a positive grid wire it will undoubtedly go to the grid, but if its path is between the grid wires it will go either to the grid or the plate, whichever influence is the stronger. Since the voltage of the plate, in normal operation, is always much higher than that of the grid, the greater proportion of the electrons go through the grid wires to the plate. However, the grid is much closer to the cathode than is the plate and its effects on the electron cloud, volt for volt, are correspondingly greater than the effects of the plate.

If the plate voltage is increased a slight amount, the additional penetration of its positive field into the electron cloud or space charge is slight, because of the shielding action of the grid with regard to the plate voltage or any changes therein.

The conditions are illustrated in Fig. 5, where there are shown three potential gradient curves for different values of plate voltage in a three-element tube. It can be seen that large variations in plate voltage have only a minor effect on the space charge surrounding the cathode. Since the control grid is nearer to the cathode it has the greater effect on the space charge; the relative effects illustrate the amplifying action of the tube. The plate voltage is varied, with the grid at constant potential. Note there is not much change in the potential gradient and hence in the

space charge in the grid-to-cathode space. As was indicated previously, since the space charge here is greatest, it has the greatest effect on i_b ; hence i_b is altered very little by changes in plate voltage.

Since the plate current is determined by the number of electrons that can be moved from the cathode into the interelectrode space, then if the field from the plate penetrates the grid openings to a minor degree, it will affect the pull on the electrons on the cathode to the same minor degree, and a change in plate voltage will, therefore produce but a small change in plate current.

In the case of diode rectifiers (especially mercury-vapor rectifiers) used in power supplies, large plate currents are desired and the tubes are operated close to the current

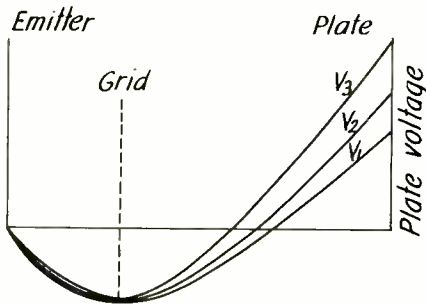

Fig. 5.—Effect on space charge for three different values of plate voltage.

saturation point. But with triodes, pentodes and other multi-element tubes, it is desired to control the flow of space current from cathode to plate by applying a varying potential between control grid and cathode, and this can only be done

(without introducing excessive distortion into the output) when there is an excess of electrons or 'cloud' surrounding the cathode. In this condition the plate current is limited by the space charge between the cathode and plate which balances the positive plate attraction on the emitted electrons. This is the normal operating condition for multi-element tubes. (See curves cd, ba, gh, of Fig. 4.)

When the grid is made slightly positive the condition is different. The grid is very close to the cathode and therefore close to the electron cloud, and its positive charge counteracts a much larger portion of the space charge then does a corresponding increase of plate voltage.

The effects of the positive grid may be tabulated as follows:

1. Counteracts a portion of the space charge.
2. Increases the plate current.
3. Decreases the plate to cathode resistance.
4. Causes a flow of grid current.

Consider the effects of a negative charge on the grid. A positive charge on the grid tends to neutralize the space charge effect which is negative. Therefore the effects of the negative grid must be exactly opposite, adding to the effects of the space charge.

The space charge, being negative, causes the electron cloud to contract toward the cathode. If a stationary wall of electrons could be placed between the plate and cathode, it would be possible to make the negative charge so great that no electrons could attain sufficient velocity to penetrate the repelling effect of this high negative charge,

and as a result all the electrons would be slowed down and forced back to the cathode, none would reach the plate. Under that condition the plate and grid currents would be zero and the tube would be said to be 'blocked'.

If this stationary wall of electrons is made less dense a few electrons can penetrate it and go to the plate. The *effect* of a wall of electrons can be obtained by placing a negative charge on the grid. If the negative charge is made sufficiently high the repelling force will be so great that none of the emitted electrons can overcome it and go to the plate. The plate to cathode resistance will then be infinite. With lower values of negative potential on the grid a small plate current will flow and the plate to cathode resistance will be high, but not infinite. (The term infinite is used in a relative sense only. It does not take into consideration leakage across the glass between tube elements.)

The higher the value of plate to cathode resistance, the more rapidly the plate voltage will drop off. If the negative charge of the grid is greater than the positive charge of the plate at some particular point in space between the grid and plate, this point and all points between it and the cathode will actually be negative with respect to the cathode. In other words, the plate voltage will be entirely expended in overcoming the negative effects of the space charge and the negative grid before the grid is reached. At the point where the positive charge of the plate is exactly neutralized by the combined negative charges, the voltage with respect to the cathode will be zero.

Between this point (zero) and the plate, the voltage with respect to the cathode will be positive. Between this zero point and the cathode, the voltage with respect to the cathode will be negative, the highest negative voltage being at the grid itself.

Under such a condition the electron which reaches the plate must attain sufficient velocity to penetrate through the combined effects of the space charge and the negative grid to beyond the zero potential point. Once having passed the zero potential point the electron will surely go to the plate. As the grid voltage is made more and more negative it becomes increasingly more difficult for an electron to attain sufficient velocity to penetrate the negative space charge, and if the grid is made sufficiently negative no electrons will reach the plate.

As the grid is made negative it has a repelling effect on electrons and for that reason no electrons go to the grid. Therefore with a negative grid there is no grid current. Tabulating the effects of a negative grid:

1. *It adds to and increases the effects of the space charge.*
2. *It decreases the plate current.*
3. *It increases the plate to cathode resistance.*
4. *It prohibits the flow of grid current.*

Care must be taken not to confuse the terms 'zero grid' and 'free grid.' A free grid is the condition obtained when the grid is in the tube but insulated from the cathode and plate, that is, having no conducting circuit back to the cathode.

In that condition with electrons passing between the cathode and the plate, some strike the grid and stick. Having no way to return to the cathode except leakage through the insulation of the tube, they collect in excess on the grid and the grid assumes a negative charge. The value of this negative charge depends upon the cathode emission and the plate voltage, increasing with increased emission and decreasing with increased plate voltage.

The actual negative voltage assumed by the free grid under normal static conditions is usually not high. However, when placed in a circuit connected through a capacitor to a source of alternating voltage with no direct current return for the electrons to the cathode, the grid can swing highly positive due to the positive alternation of the alternating voltage, and while positive, collect sufficient electrons to completely block the tube until the accumulated negative charge leaks off. It is almost an axiom in radio practice that a tube is NEVER operated with a free grid.

As explained in the assignment on Thermionic Emission, the plate current in a diode, when limited by space charge, is proportional to the $3/2$ power of the plate voltage e_b . In a triode—under space-charge-limited conditions—the magnitude of the plate current depends on the electrostatic field near the cathode, which is produced by the combined effects of the plate and grid voltages. In the case where the grid is negative, all of the space current goes to the plate and the plate current is proportional to the quantity $(e_c + e_b/\mu)^{3/2}$, where e_c is the

total instantaneous grid voltage, e_b is the total instantaneous plate voltage and μ is the amplification factor. If the grid is made sufficiently negative such that $e_c = e_b/\mu$, then the plate current is reduced to zero. Hence, we can say that the plate current cut-off grid bias is equal to $-e_b/\mu$.

SECONDARY EMISSION.—At this point it is well to consider 'secondary emission' in connection with the operation of the grid and plate. Electron emission from a conductor may be caused by impact just as electrons may be dislodged from a molecule of gas during ionization. When an electron traveling at the rate of many miles per second strikes the plate it causes other electrons to be 'splashed' out from the surface of the plate. Normally with the plate highly positive these electrons are immediately attracted back to the plate.

However, under certain conditions this phenomenon, which is known as 'secondary emission', can cause considerable trouble. For example, in the case of a four element screen-grid tube (to be studied later) a second grid is placed between the plate and the control grid and held positive by a potential equal to about one-third (usually) that of the plate potential. This voltage is constant, while in operation the plate voltage is varied over wide limits. Now when the plate voltage swings considerably below the positive potential of the screen grid, the electrons due to secondary emission from the plate will be attracted to the screen grid and this reverse current, deducting from the regular plate current, causes an abnormal decrease in peak plate current and distortion in the output.

In a similar manner, electrons traveling between the cathode and plate may strike the grid at high velocity and cause secondary emission. One electron striking the grid may cause the emission by impact of two or more electrons, the additional electrons going to the highly positive plate. Normally grid current flow in the external circuit is from the grid to cathode, the positive grid attracting electrons emitted by the cathode and returning them to the cathode through the external circuit. This is the normal grid current observed in a transmitter during operation. However, under certain conditions of adjustment, more electrons may leave the grid due to secondary emission than are attracted to it from the cathode. These excess electrons return to the cathode circuit through the plate circuit and from there back to the grid *through the external grid circuit*. This will be indicated by a *reversed grid current reading in the grid milliammeter*. (In the design of transmitting tubes special precautions are taken to minimize secondary emission from both the plate and grid.)

In the case of the screen-grid tube where secondary emission from the plate becomes particularly objectionable, a third grid may be added to minimize the undesirable conditions arising. The tube is then called a *pentode*, from the fact that it has *five* elements. In the conventional design of the power pentode for use in the last audio stage in broadcast receivers this third grid, called the *suppressor grid*, is placed between the plate and the screen grid and connected to the cathode within the tube. It simply forms a grounded electro-

static shield between the plate and screen grid, preventing the field of the screen grid from extending into the vicinity of the plate when the plate voltage swings to low values during operation. A more detailed description of the action of a suppressor grid is given in a following assignment.

GRID CONSTRUCTION AND MOUNTING.—Since the grid is placed close to the filament where the effect of its voltage on the space charge will be great, the construction and mounting of the grid must be very exact. One manufacturer states that the diameter of the grids in receiving tubes are measured to .001 inch and that the diameter of the wire does not vary more than .00009 inch. The grid wire is very small and is exposed to the heat radiated from filament and plate, so that it is necessary to use for this purpose a metal which will not soften or stretch appreciably at the somewhat higher than normal operating temperatures at which the tubes are evacuated. The same consideration applies to the grid supports.

Tungsten is used to some extent for grid wire, but the most commonly used material is molybdenum. Svea metal is also used to a considerable extent in receiving tubes. The characteristics of these metals have already been discussed.

Stretching under heat, or misplacement of the grid wires due to improper handling in shipment or in use, can completely change the tube characteristics. The long operating life of modern vacuum tubes, and the closeness with which the characteristics of tubes may be matched in service when replacements become necessary, speak very highly for the skill and care with which tubes are

designed and manufactured.

EFFECTS OF GRID VOLTAGE VARIATIONS ON THE PLATE CURRENT.—Normally a three (or more) element vacuum tube makes use of the variation in plate current produced by a variation in grid voltage. As an amplifier tube, a small change in its grid voltage should produce a large change in its plate current; this depends upon the geometry of the tube.

The amplification factor or μ increases as the grid-to-plate distance is increased, since the more remote the plate is the more influence the grid has upon the electrons issuing from the cathode. μ also increases when the spacing between grid wires is decreased, since it becomes a more effective shield between the plate and cathode.

The shielding and hence μ are also increased by increasing the grid-wire size, even if the spacing between wires is kept constant. On the other hand, the cathode-grid spacing has no appreciable effect on the μ of a vacuum tube so long as this distance is equal to or greater than the spacing between grid-wires.

This may be appreciated by considering the conditions that exist at cutoff. The electric field at the cathode is zero at cutoff; i.e., the force acting on the electrons is zero and hence they do not leave the cathode. This means that all electric field lines issuing from the positive plate terminate on the grid, and any passing through the grid openings curl around and return to the grid wires.

This is true so long as the cathode is not too close to the grid, whereupon the field pattern is not disturbed if the grid is moved

even farther away from the cathode; i.e., grid spacings greater than the above critical value have little effect on the electric field conditions existing at the cathode. As a result, the amplification factor is independent of the cathode-grid distance if the latter exceeds the above critical minimum value.

If, however, the cathode-grid distance is less than the grid-wire spacing, the potential gradient is not constant over the cathode surface. Instead, it varies with respect to whether a point on the cathode surface is in front of a grid wire, or in front of an opening in the grid. Such a tube exhibits no true cutoff condition, because as the grid is made more and more negative the cathode voltage gradient opposite the grid wires will become more strongly repelling to the electrons, while the cathode gradient between the wires is less repelling. This gives rise to a condition in which little areas of the cathode opposite the openings are emitting, while other areas opposite the grid wires are not. Such a tube acts as a variable- μ tube, since every part of the cathode has a different amplification factor. (The variable- μ tube will be described farther on.)

The so-called 'high- μ ,' (meaning high amplification factor), triodes have a very high plate to cathode resistance and are used mostly in resistance coupled amplifiers with a plate load resistance several times that of the ordinary amplifier tube. In the case of the 6C5 operating with a d-c plate potential of 300 volts, if a load resistance of 50,000 ohms is used, a voltage gain of 11 is obtained. If

the value of the load resistance is increased to 250,000 ohms, a voltage gain of 14 may be obtained. The 6F5 having a higher plate resistance and amplification factor, is ordinarily used with a higher load resistance. Thus with load resistance of 100,000 ohms, the voltage gain may be as high as 52. With load resistance of 500,000 ohms the voltage gain may be as high as 70. *It should be noted that the actual voltage gain in a resistance coupled amplifier is never as great as the tube amplification factor.* The actual voltage gain is a function of the circuit constants, as will be explained in detail in later assignments.

Typical values of μ for several triode type tubes were given previously; in general, four and five element tubes have higher amplification factors than do triodes; e. g. the 6L6 has a μ of approximately 135—the 6F6 power pentode has an amplification factor of 200. The 35L6 has a μ of 80. It should be pointed out that at high frequencies, the value of transconductance, G_m , is a more important factor in determining the gain of a stage than is μ ; this will be explained more thoroughly in the study of screen-grid type tubes.

The circuit and operating conditions necessary to obtain the maximum amplification from any tube will be taken up in detail in later assignments. So far as the tube itself is concerned, the amplification factor is determined by the geometry of the tube as already explained, but it is necessary to properly operate the tube to obtain the rated voltage gain.

CURRENT SATURATION.—As mentioned earlier in this assignment, if a sufficiently high negative

charge is placed on the grid, all of the electron flow from the cathode to the plate can be shut off and the tube is then said to be blocked. On the other hand if a sufficiently high positive charge is placed on the grid, the space charge can be completely counteracted and every electron emitted by the cathode will go to either the plate or the grid, and the condition of saturation will exist. As the grid is first made positive and the positive charge is then increased, the plate current will increase. At the same time grid current will flow, the grid current also increasing with the increased positive charge on the grid.

As the grid is made more and more positive, both plate and grid currents increase until every electron emitted is going to either the plate or the grid. This is the *current saturation point*. If the positive charge on the grid is further increased beyond the saturation point, the grid current will continue to rise *BUT THE PLATE CURRENT WILL DECREASE*.

The explanation of this condition is very simple. When the saturation point is reached every electron emitted goes to either the plate or the grid. The grid is much closer to the cathode than is the plate and all the electrons going to the plate must pass between the grid wires. If the grid is made sufficiently positive it will act as a plate and attract every electron to it before those electrons can get to the plate, and as a result there will be no plate current. This is an extreme condition and is *never* encountered in a tube's normal operation.

Normally a tube is rarely

worked as high as the saturation point, but momentary saturation under some conditions is encountered in transmitter operation and should be thoroughly understood. An example of driving the tube to saturation is the Class C amplifier which is to be used as a modulated amplifier. The saturated condition however occurs only for a very small portion of each radio frequency cycle, and over a much larger portion of the cycle the grid is negative and draws no grid current. If the grid is made very highly positive for an appreciable length of time, it will probably burn up due to excessive electronic bombardment, i.e. large grid current.

GRAPHICAL CONSIDERATIONS

TUBE CHARACTERISTIC CURVES. — In Fig. 6, a characteristic curve for a three element tube is shown with plate current plotted against grid voltage. As the grid is made positive, grid current flows as shown by curve i_g . Curve i_p represents the plate current. In this diagram, for the purpose of simplicity, reduced cathode emission and low plate voltage have been assumed so that comparatively small variations in grid voltage will have very pronounced effects.

A study of the plate current curve in Fig. 6 brings out several facts. First, with the given plate voltage and cathode emission it requires a negative charge of approximately eight volts to completely block the tube. Second, under the same conditions, the tube will saturate with a positive grid charge of between six and seven volts. Beyond this point the grid current

will continue to increase and the plate current will decrease by the same amount as the increase of grid current. This is shown by the dotted lines when the positive charge on the grid is increased beyond the point of saturation.

A very important point to observe is the shape of the curve between point 'a' of zero plate current and point 'b' of saturation plate current. The increase of plate current is in the form of a curve between points 'a' and 'x', essentially linear between points 'x' and 'y', and again assuming a curved shape between points 'y' and 'b'.

Between points 'a' and 'x' a variation of grid voltage, due to the space charge effect being so great, has a comparatively small effect on the plate current; the effect however, increases as point 'x' is approached. Between points 'x' and 'y' grid voltage variations will cause linear variations of plate current. Linear variations of plate current are necessary if the tube is to be operated as an amplifier without distortion.

From 'y' to 'b' the rise becomes more and more gradual, the plate current increase ceasing at point 'b'. The reason for the gradual curvature beginning at 'y' is the fact that the grid current is beginning to assume fairly large proportions, and since the sum of the plate and grid currents at this point is near the saturation value of the emitted electrons, the rapid increase in grid current slows up the increase in plate current, and at a lower value than necessary for saturation will actually decrease the plate current. The result of the dip or distortion in the plate

current curve at the positive peak of the grid voltage cycle, when the grid voltage is permitted to swing beyond the straight portion of the characteristic, is the development of strong harmonic components in the tube output. The proportion of the

are identical. It is apparent that a variation of grid voltage can produce the same effect on the plate current as a similar form of variation in the plate voltage. The difference, however, is in the *amplitudes* of the voltage variations re-

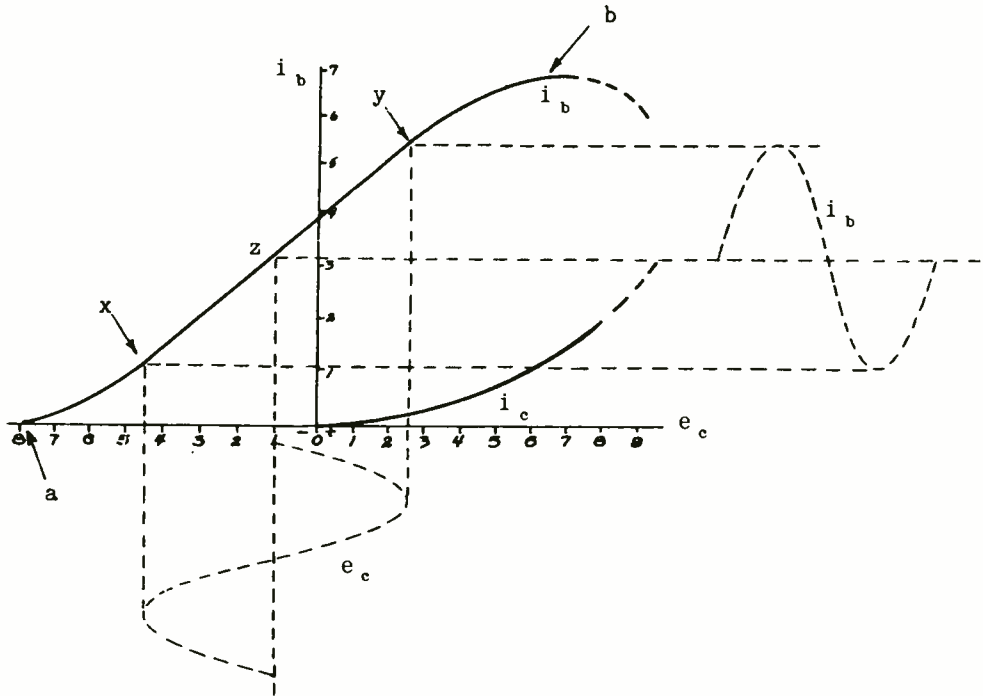

Fig. 6.—Plot of plate current versus grid voltage and that of grid current versus grid voltage.

energy in the harmonic frequencies compared to the total output of the tube, increases as the grid voltage swing is increased beyond the linear portion of the curve.

An examination of the i_b curve of Fig. 6 in comparison with the curve of plate current plotted against the plate voltage for a two element tube will bring out the fact that the shapes of the two curves

quired to produce a given variation in plate current. In order to vary the plate current from zero to saturation by means of a variation of plate voltage, it will be necessary to vary the plate voltage from zero to a very high value, the value depending upon the temperature of the emitter. A very much smaller grid voltage variation will accomplish the same result.

In order to amplify without distortion it is necessary to cause the plate current variations to take place within the limits of the straight portion of the $i_p e_c$ (grid voltage-plate current) curve. Therefore if the maximum variations within this limit are to be obtained, the variations must take place around a point in the exact center of the straight portion of the characteristic. In Fig. 6, the exact center of the straight portion is at point 'z'. Therefore if the grid voltage is caused to vary around point 'z', remaining within the limits x-y, the plate current variations due to the varying grid voltage will be exactly the same form as the grid voltage variations.

In the tube characteristic curve of which is shown in Fig. 6, under the given conditions of emitter temperature and plate voltage, the maximum *undistorted* output will be obtained when the grid voltage is varied around a fixed value of one volt negative, and the grid voltage varied three and one-half volts in each direction. This means that the grid must swing between four and one-half volts negative and two and one-half volts positive.

If the amplitude of grid voltage variations is less than this, maximum output will not be obtained. If the amplitude of grid voltage variations is greater, the plate current variations will also be larger but the top and bottom of the plate current variations will be flattened out, and distortion will result.

The curve of plate current plotted against grid voltage is one of the most important and practical curves that can be taken on a three element tube, because it shows the

point at which the tube should be worked, and the limits within which the grid voltage variations must be held for undistorted amplification. At the same time it allows a simple calculation of the voltages which should be used to obtain desired results.

For example, if the fixed potential on the grid is to be such that the alternating grid voltage will vary around a point at the center of the straight portion, it is only necessary to find by measurement the exact center of the straight portion, drop a perpendicular from that point, and the point at which the perpendicular intersects the grid voltage line will indicate that proper fixed grid voltage to use. Fig. 6 shows point 'z' at the center of the straight portion; the perpendicular intersects the grid voltage line at one volt negative, indicating that the fixed grid voltage should be one volt negative.

This curve also allows a quick determination as to whether the tube has a high or a low amplification factor. If the inclination of the curve is very steep it indicates a high amplification factor, because it shows that the change in plate current for a unit variation in grid voltage is high. If the curve of another tube, plotted to the same scale, is not so steep, the second tube will have a lower amplification factor because the same grid voltage variation will cause a smaller change in plate current.

The $E I_p$ curve is plotted from readings obtained with a circuit as shown in Fig. 7. The construction of this circuit is very simple and the readings are easily obtained. Voltmeter V_1 indicates the fixed

plate voltage. This must be known because it is a determining factor in the operation of the tube. The filament voltmeter should be used in order that the filament may be held at the normal operating temperature. Voltmeter V_2 indicates the voltage applied to the grid between the grid

switch S.

The milliammeter in the plate circuit, ma_1 , indicates the current (i_b) in the plate circuit. This reading is plotted against the reading of the grid voltmeter, V_2 to obtain the $i_b e_c$ curve.

The milliammeter in the grid circuit, MA_2 , indicates the current in the grid circuit. Grid current is indicated only when the voltage on the grid is positive. The reading of ma_2 plotted against grid voltage produces the curve i_c also shown in Fig. 6.

When a curve is plotted, the value of plate voltage should be noted on the curve. Also somewhere on the sheet should be marked the filament current or voltage; if this is kept at the value normal for the type of tube being tested it may simply be indicated, ' I_f normal.'

The curves plotted with the circuit shown in Fig. 7 will be the static characteristic curves and will not give a true indication of the operation of the tube when worked into a load of the correct impedance to obtain the maximum output from the tube.

To obtain actual operating data a set of dynamic characteristic curves should be plotted using the load impedance into which the tube is to be operated. The circuit shown in Fig. 7 may be used with the exception that the load resistor should be connected between the positive terminal of the battery and the plate, either above or below the plate milliammeter.

Since the load resistor is connected in series with the resistance of the tube and battery, the total resistance of the plate circuit will be increased, and for a given plate supply voltage, a given grid voltage

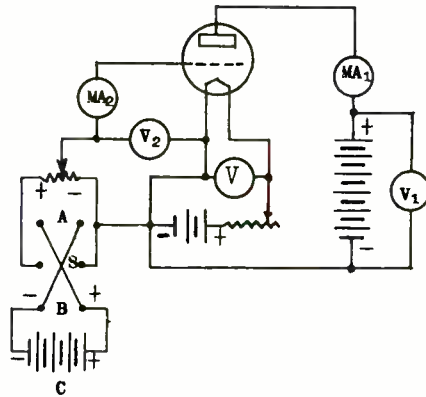

Fig. 7.—Circuit arrangement for measuring plate current versus grid voltage.

and the zero point of the filament.

When switch S is changed from position A to position B, the connections to V_2 must be reversed. The potential applied to the grid with respect to the filament will be positive when the switch is in position A and negative when in position B. The amplitude of the voltage applied to the grid will depend upon the position of the variable arm along the potentiometer and may be varied from zero when at the end of the resistor next to the filament to the full voltage of the battery, C, when at the extreme end of the resistor away from the filament; the polarity of this voltage of course depending upon the position of

variation will not cause so great a variation in plate current as would be the case if the load resistor were not in the circuit. This will result in a characteristic curve that is much more straight, long and flat, than the curve plotted without the use of a load resistor. If several values of resistance are used, it will be observed that the higher the value of resistance the flatter and straighter the curve. Thus if it is desired to operate the tube to the limit with high excitation and without distortion, the load impedance must be high.

The difference in the shape of the $i_b e_c$ curve for different values of plate voltage is shown in Fig. 8.

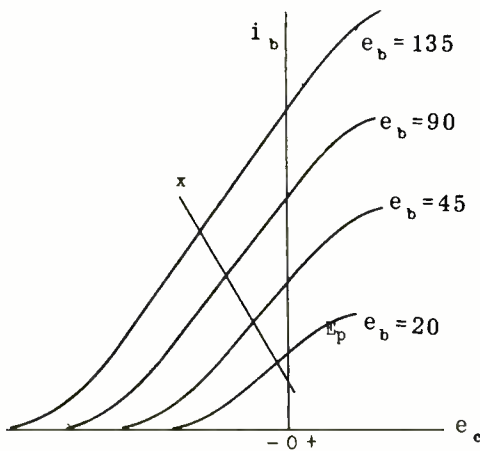

Fig. 8.—Plate current versus grid voltage for various values of plate voltage.

It will be observed that the higher the value of plate voltage the

longer the straight portion of the curve becomes, within well defined limits. Almost the entire curve with 135 volts applied to the plate is obtained with the grid negative with respect to the filament.

It should also be noted that with higher plate voltages, the total permissible swing of plate current for variations of grid voltage may be much greater without swinging off the straight portion of the characteristic. This means that the use of a higher plate voltage will permit the *HANDLING* of much greater voltage amplitudes, that is, a much greater input voltage on the grid without distortion in the output. This applies to both broadcast transmitters and audio-frequency amplifiers of broadcast receivers, in both of which any distortion is very undesirable. In that connection, a marked distinction should be made between *producing* large signal voltage and the ability to *handle* large signal voltage. The high plate voltage does not necessarily cause more amplification or a greater signal amplitude for a given grid voltage variation, but it permits the handling of larger a-c grid voltages without distortion. This is an important distinction that is not always understood. Most of the three element power tubes actually have a lower amplification factor than do the smaller triodes, but they will *handle* much greater signal amplitude without distortion.

Line 'x' in Fig. 8 intersects the centers of the linear portions of the characteristics for the different plate voltages, and indicates very clearly that as the plate voltage is increased the fixed value of negative grid voltage (bias) must also be increased in order to keep

the operating point in the center of the linear portion. Thus as the plate voltage is increased the negative voltage (bias) on the grid must also be increased.

Fig. 9 shows a group of $i_b e_c$ curves taken for a single tube with different plate voltages. This tube is a power amplifier and the curves bring out in an excellent manner the operation of the tube. One point which should particularly be observed is that if the grid is permitted to swing positive and a high plate voltage is used, the tube is capable of developing *far* more power than can be obtained if the grid swing is restricted to the negative range only.

This discussion has emphasized the advantage of making the operating point at the center of the straight portion of the $i_b e_c$ curve. This is done in Class A operation and *THE GRID IS NOT PERMITTED TO SWING POSITIVE*. Under such conditions of Fig. 9, with the highest plate voltage shown, (350 volts), the grid would be biased at -20 volts, the plate current would be approximately 45 milliamperes, and the grid could be permitted to swing with excitation between the limits of -40 volts to 0 volts. The plate current would vary around the 45 mil point from 15 mils to 85 mils.

It will be observed that even this restricted swing will permit some distortion in the output, because on the positive excitation swing, the plate current increases from 45 to 85 mils; on the negative swing it varies from 45 mils to 15 mils, a variation of 40 mils on one alternation and 30 mils on the other. This is due to the lower curvature of the characteristic. Less distortion with somewhat reduc-

ed output would be obtained by operating with bias of about -16 volts and excitation voltage swing between 0 and -32 volts. The total i_b variation is less but the difference between the two alternation peaks is also much less.

In Class B operation the tube is biased back to about the cutoff point, the excitation is increased to the point where the grid swings considerably positive, and the peak amplitudes of plate current are very high. However on the negative excitation alternation the grid voltage is beyond cutoff, no plate current flows, and the plate is permitted to cool, so that even with large excitation voltage and high *peak* plate current, the *average* plate current will be comparatively small. Thus with the higher operating efficiency a comparatively small tube operated Class B can be made to deliver greater power output and much higher peak power than when operating Class A. When operating Class B, special circuits and apparatus must be used to prevent excessive harmonic distortion. This will be discussed in greater detail later.

The curves of Fig. 9 show the effect of increased plate voltage on the grid current. For a given positive grid voltage, as the plate voltage is increased the grid current is decreased. The higher plate voltage increases the electron velocity, more electrons go between the grid wires to the plate, and the given positive grid potential does not deflect so many electrons from their course so as to cause them to strike the grid.

Fig. 10 illustrates a 'family' of $i_b e_c$ (plate voltage-plate current) tube characteristic curves which are extremely useful in an analysis of

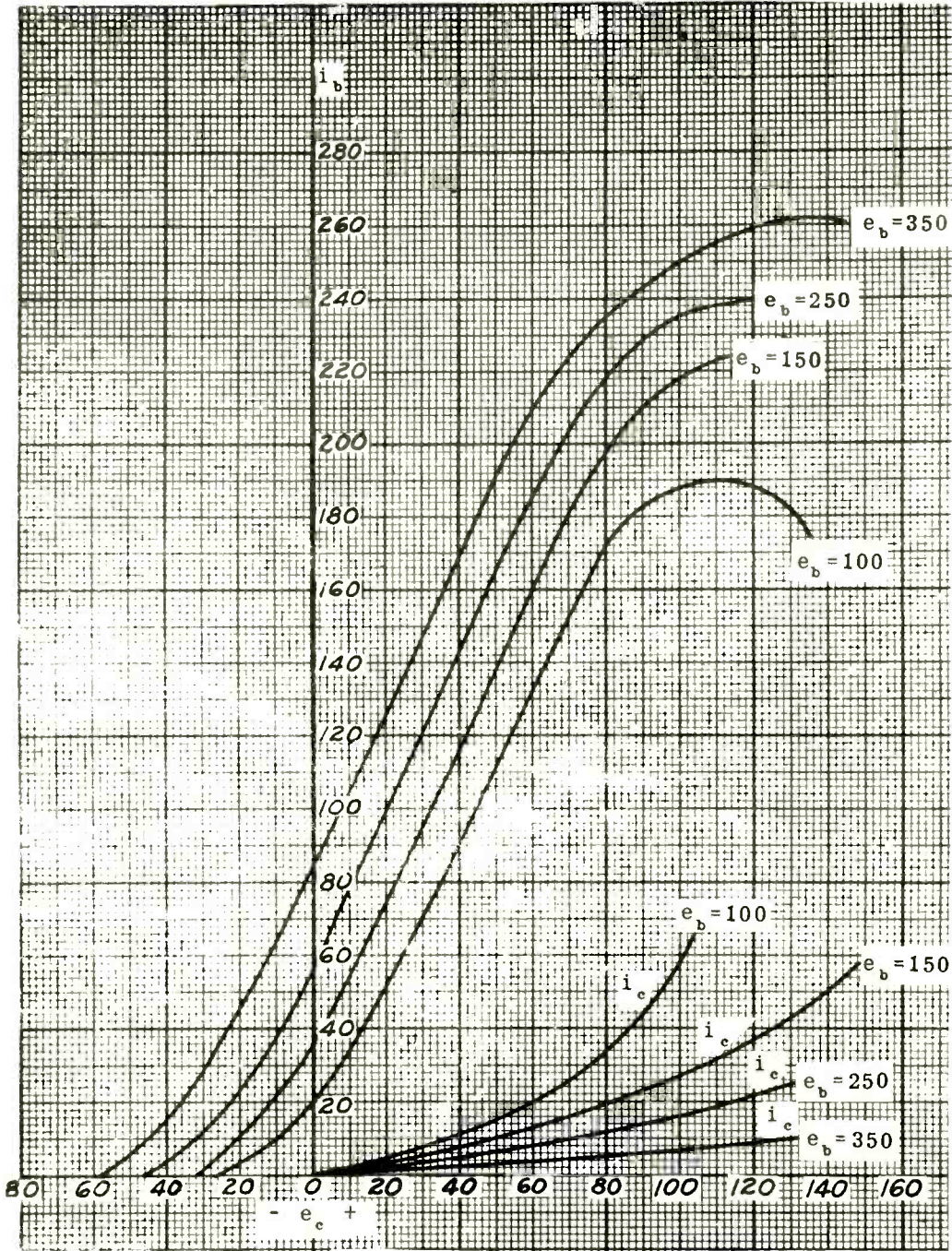

Fig. 9. — $i_b e_c$ curves (with the plate voltage as the parameter) for a power tube.

the tube operation into any given load impedance. Each curve represents the range of plate current for a range of plate voltage variation with a specified grid bias voltage. In taking the readings for plotting the curves, the grid bias is fixed and the plate voltage is varied over the desired range, plate current readings being noted at regular intervals of plate voltage. Then the grid bias is changed and another complete set of $i_b e_b$ readings taken, etc. This is probably the most useful of all types of characteristic curves in the analysis of vacuum tube operation. The importance of the family of $i_b e_b$ curves will become more apparent in following assignments.

The voltage on the grid of a tube may be divided up into two distinct components; a d-c component and an a-c component. Both voltages are present at all times when a tube is actually operating.

The d-c voltage is called the 'grid bias' and is usually negative. This voltage is supplied by a battery, generator, rectifier, or a voltage drop across a resistor. The different methods of obtaining the bias voltage will be discussed in detail later.

The a-c voltage is positive on one alternation and negative on the other, and the total voltage on the grid at any instant is the algebraic sum of the a-c and the d-c components. The a-c component is called the 'Grid excitation' voltage.

If a negative bias of 10 volts is used, and an excitation voltage in the form of a sine curve having a maximum amplitude of 8 volts is applied, the actual voltage on the grid will vary between the algebraic sums on the two alternations. The

grid bias being 10 volts negative, when the excitation voltage is on the peak of its negative swing its negative value of 8 volts adds algebraically to the bias and $e_c = (-10) + (-8) = -18$ volts.

On the next alternation the peak excitation voltage becomes 8 volts positive and again adding algebraically, $e_c = (-10) + 8 = -2$ volts.

Under these conditions the actual grid voltage varies between 2 volts negative and 18 volts negative, and at no time will the grid be actually positive; therefore no grid current will flow.

The methods of obtaining the excitation voltage are numerous and will be discussed in detail in succeeding assignments. Briefly, the excitation voltages may be divided into three classes, via: resistance drop IR ; inductive drop, IX_L , capacity drop, IX_C . The excitation voltages may be at audio, video, or radio frequency, depending upon the use to which the tube is put.

CALCULATING TUBE CONSTANTS

TRIODE CONSTANTS.—The three fundamental constants of a triode are amplification factor, dynamic plate resistance and grid-plate transconductance. The symbols for each of these are μ , R_p and G_m in the order mentioned above. The student must have a thorough understanding of these factors since they appear frequently in equations applicable to tube operation. These constants can be calculated from the geometry of the tube but this leads to complicated equations that require values rarely available to anyone except the tube design engi-

neer. As will be shown μ , G_m , and R_p can be calculated graphically from tube curves with accuracy sufficient for all practical purposes.

approximation. Using the curves of Fig. 9 when $e_b = 150$ volts and $e_c = 0$, then $i_b = 36$ ma. When $e_b = 350$ volts and $e_c = 0$ then $i_b = 85$ ma.

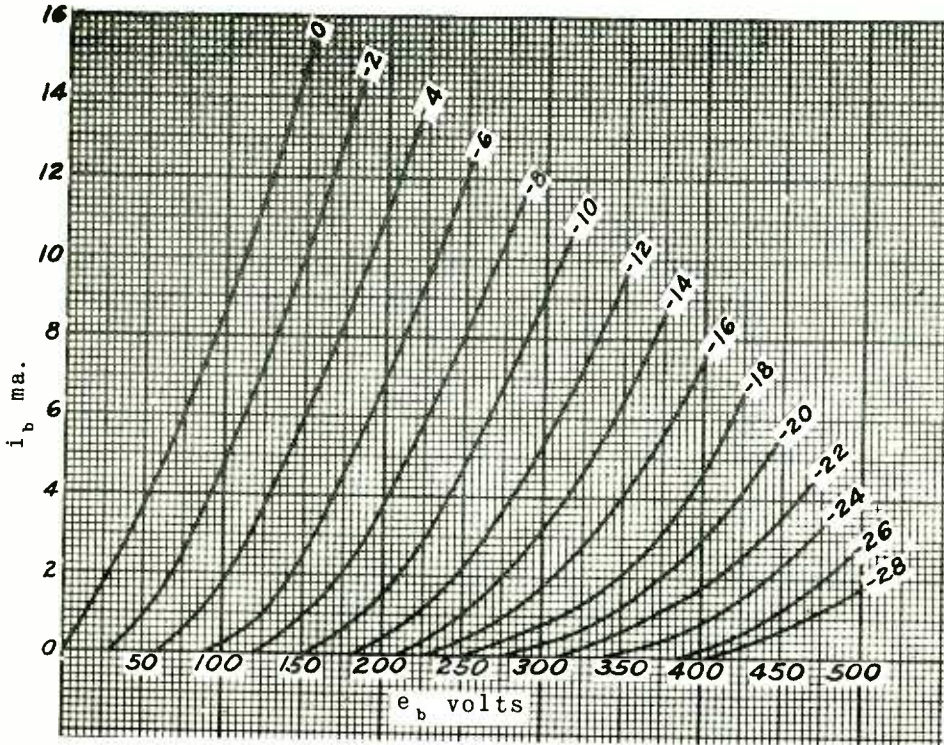

Fig. 10.—Plate current versus plate voltage with the grid voltage as the parameter.

AMPLIFICATION FACTOR.—The amplification factor, μ , of a tube is defined as the ratio of the change in plate voltage to the change in grid voltage to maintain the plate current unchanged. For example, if a 40 volt increase in plate voltage increases the plate current one milliampere and -2 volts increase in grid voltage decreases i_b one milliampere then $\mu = 40/2 = 20$.

The amplification factor of any tube can be readily calculated graphically from either a family of $i_b e_c$ or $i_b e_b$ curves. If care is used μ can be found to a very fair

Thus a 200 volt increase in plate voltage increases i_b 49 ma. If $e_b = 350$ volts and $i_b = 85$ ma at zero grid volts, to reduce i_b to 36 ma e_c must be increased from zero to -25 volts. In other words changing e_c 25 volts has the same effect as changing e_b 200 volts. $\mu = de_b / de_c = 200/25 = 8$.

Using the $i_b e_b$ curves of Fig. 10, when $e_b = 250$ volts, $e_c = -8$ volts, $i_b = 8$ ma. When $e_b = 250$ volts, $e_c = -6$ volts, $i_b = 12$ ma or -2 volt change in e_c causes a 4 ma change in i_b . With $e_b = 250$ volts, $e_c = -6$ volts, i_b can be reduced to

8 ma by decreasing e_b to 210 volts. A 40 volt change in e_b has the same effect on i_b as a 2 volt change in e_c . $\mu = de_b/de_c = 40/2 = 20$.

The amplification factor is sometimes defined as the slope of the $e_b e_c$ curve. This curve is of little practical importance and will not be discussed here. For any given tube, μ will remain reasonably constant over the operating range, that is, the straight portions of the $i_b e_c$ curves. μ will decrease if the excitation is such as to swing into the upper or lower bends of the curves. This explains how distortion occurs in the tube, since any variation of μ over the operating range of the tube will result in unequal amplification of all parts of the excitation cycle, and the output will not be an exact amplified reproduction of the input.

Some distortion will occur even when the tube is operated over the linear portion of the curves because it is evident that some curvature exists at any point on the curve. In the case of a Class A amplifier where very small excitation voltages are used the characteristic curve is practically a straight line because only a very small part of the total curve is utilized. However, in power tubes the full length of the straight portion of the curve is used, and because the curve is not a true straight line over any appreciable distance some variation in μ will be evident and therefore some distortion will exist.

PLATE RESISTANCE.—The dynamic plate resistance should never be confused with the static plate resistance of the tube. The static plate resistance is the ratio of the plate voltage to plate current at the operating point or E_b/I_b for any

fixed e_c . It is often called the d-c resistance of the tube. The dynamic plate resistance R_p is the ratio of change in e_b to the change in i_b with e_c constant or $R_p = de_b/di_b$ for fixed e_c . R_p can also be determined graphically from a family of $i_b e_c$ or $i_b e_b$ curves.

In Fig. 9, when $e_c = 0$ and $e_b = 350$ volts, $i_b = 85$ ma. When $e_c = 0$ and $e_b = 150$ volts, $i_b = 36$ ma. For a change in e_b of 200 volts, i_b varies 49 ma. $R_p = de_b/di_b = 200/.049 = 4082$ ohms. Using Fig. 10, when $e_b = 200$ volts, $e_c = -6$ volts, $i_b = 7$ ma. When $e_b = 210$ volts, $e_c = -6$ volts, $i_b = 8$ ma. For a 10 volt change in e_b , i_b varies 1 ma. $R_p = 10/.001 = 10,000$ ohms.

The plate resistance may also be defined as the reciprocal of the slope of the $i_b e_b$ curve at the point of operation. This is shown in Fig. 11. $\tan \theta = \text{opposite side/adjacent side} = i_b/e_b$ but $R_p = e_b/i_b$, therefore $R_p = 1/\tan \theta = \text{adjacent/opposite} = \cot \theta$. Since $\tan \theta$ is the slope of the curve at point θ then R_p must be the reciprocal of the slope of the curve.

Fig. 11 also indicates the great difference that may exist between the static and dynamic plate resistance. The dotted lines show the static plate current that flows for a given E_b with fixed bias. Static $R_p = E_b/I_b = \cot \theta$. It should be noted that R_p may be infinite below cutoff bias and again approach infinity at saturation plate current because the slope of the $i_b e_b$ curve approaches zero at these limits. For very small variations of plate current over the working range of the tube, R_p may be assumed to be constant with sufficient accuracy for most calculations. In calculating R_p from characteristic curves

greatest accuracy is obtained when only very small increments of e_b and i_b are used.

GRID PLATE TRANSCONDUCTANCE.—
The grid plate transconductance

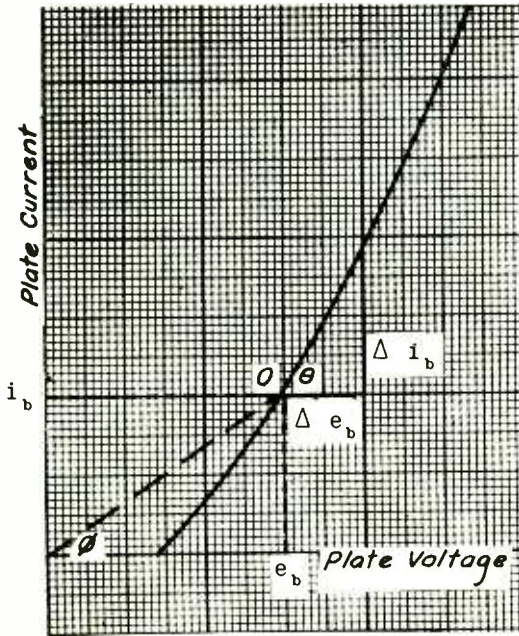

Fig. 11.—Illustration of how the a-c and d-c plate resistances can be determined from an $i_b e_b$ curve.

(often called mutual conductance) is one of the most important tube constants and is defined as the ratio of a change in plate current to a change in grid voltage with fixed plate voltage or $G_m = di_b/de_c$, $de_b = 0$.

Like μ and R_p , G_m can be approximated from a family of $i_b e_c$ or $i_b e_b$ curves. In Fig. 9, if e_b is constant at 350 volts then increasing e_c from zero to -25 volts decreases i_b from 85 to 36 ma. A change of 25 volts in e_c causes a .049 ampere change in i_b . $G_m =$

$di_b/de_c = .049/25 = .00196$ MHO = 1960 micro-mhos.

In Fig. 10, when $e_b = 250$ volts changing e_c from -8 to -6 volts (change of 2 volts) varies i_b from 8 to 12 ma (change of .004 ampere). $G_m = di_b/de_c = .004/2 = .002$ Mho = 2000 micro-mhos.

The importance of G_m lies in the fact that it is a factor involving both μ and R_p . The relations between G_m , μ , and R_p are as follows

$$\mu = \frac{de_b}{de_c}$$

$$R_p = \frac{de_b}{di_b}$$

$$\mu/R_p = \frac{de_b/de_c}{de_b/di_b} = \frac{de_b \cdot di_b}{de_b \cdot de_c} = \frac{di_b}{de_c}$$

But

$$G_m = \frac{di_b}{de_c}$$

Hence

$$G_m = \mu/R_p$$

From which

$$R_p = \frac{\mu}{G_m} \text{ and } \mu = G_m R_p.$$

Since in a vacuum tube amplifier it is desirable that small variations in grid voltage produce large variations in plate current the operating point should be chosen where the slope of the $i_b e_c$ curve is steep. Since the steepness depends on G_m it is very desirable that the amplifier tube have a high trans-

conductance. The magnitude of G_m in practical tubes is limited by tube construction. Since G_m is in the nature of a conductance anything that opposes plate current will reduce the conductivity of the tube. The space charge in the tube offers the greatest opposition to current flow in the tube.

Placing the grid close to the cathode tends to reduce the effects of space charge and thus increases G_m but, as previously stated, there is a definite limit to how close the grid may be mounted to the cathode in any tube. G_m is also somewhat dependent on plate and cathode areas. In the more common triode receiving tubes G_m usually lies between 2000 and 200 micromhos. Maximum G_m for any given tube usually occurs at about the center of the straight portion of the $i_b e_c$ curve.

The grid-plate transconductance is most useful as a direct means of comparison between two tubes of the same type because it is a direct expression of the effects of the grid on the plate current. If the characteristics of two similar tubes are measured, the one having the higher mutual conductance will be the better tube. The mutual conductance of two entirely dissimilar tubes designed for different purposes should not be used as a means of comparison of the tubes.

G_m is not a critical criterion of the operation of the tube because fairly large differences in mutual conductance must occur before a difference in operation can be observed.

INTERELECTRODE CAPACITY

TUBE INPUT IMPEDANCE.—At the low and intermediate frequencies at which the reactance of a compara-

tively small capacity is very high, little difficulty is encountered in obtaining the proper amount of amplification from a given tube. At the high frequencies (above 5000 kilocycles) that is not true. At the higher frequencies the input capacity of the tube, although small, will have a comparatively low value of reactance. Also the input capacity is not so small as it would seem. Fig. 12 will show the tube

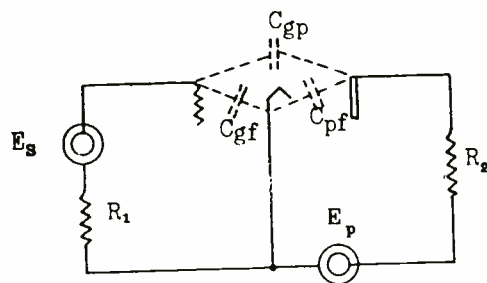

Fig. 12.—Diagram showing the interelectrode capacitances in a vacuum tube.

capacities involved. C_{gp} represents the grid-plate capacity, C_{gf} is the grid-filament capacity, C_{pf} is the plate-filament capacity. E_s is the excitation voltage, R_1 is the impedance of the tuned grid circuit across which E_s is developed, E_p represents the a-c component of plate voltage which is equal to μE_s , R_2 is the plate load impedance across which E_s is developed, E_p represents the a-c component of gain factor and not the rated or measured constant.)

If the grid is connected to one terminal of a capacity bridge and the plate and filament are connected together to the other terminal, a certain amount of capacity will be

measured. When the tube is placed in a circuit and operated under normal conditions, the effective capacity is found to be several times as large as the bridge measured amount. Also the effective input capacity *varies with the plate load impedance.*

The plate is connected through the load to the filament. (Since in practice the d-c plate and bias voltage sources are bypassed by capacitors, so far as the a-c components of voltage are concerned the d-c power supplies may be neglected.) The grid is also connected to the filament.

Assume that the grid excitation voltage E_s is 1 volt and μ is equal to 10. Then voltage E_p developed between the plate and filament is equal to 10 volts. BUT this voltage is not developed across only the plate-filament capacity C_{pf} . The grid is also connected to the filament and thus to one side of E_p . It is apparent that a voltage is impressed, through R_1 , between the total capacity existing between the grid and plate, this capacity consisting of C_{gp} in parallel with the series combination $C_{gr} C_{pf}$. Since E_s and E_p are in series, instead of this voltage being 1 volt, which would be the case if the filament was not heated and the tube *not* amplifying, actually a potential difference of 11 volts is applied across the capacity.

Thus instead of an alternating current through the capacity from grid to filament and plate corresponding to a potential difference of 1 volt as furnished by the excitation circuit, the current flow actually corresponds to that caused by an applied voltage of 11 volts. This will show up in the circuit as an effective input capacity several

times larger than that measured by means of a capacity bridge.

It has been stated that the effective input capacity varies with the plate load impedance. This is due to the fact that the actual amplification obtained with a given tube is a function of the load impedance, an incorrect adjustment of the load impedance decreasing the gain and correspondingly the voltage E_p developed across the output circuit. Since the effective capacity is a function of E_p it is also a function of the load impedance.

When this comparatively large effective capacity is connected across the excitation circuit and the frequency is made sufficiently high, the reactance (input impedance) will be so low that the current flow will approach a condition of short circuit across the excitation circuit. How high this current may be is illustrated by the fact that when power tubes are used in high-frequency circuits, it is necessary to specify the maximum permissible r-f grid current. This places a very definite limit on the excitation voltage which may be used in very high frequency operation and reduces the possible power output and operating efficiency at such frequencies. This is one of the very serious problems in the development of television transmitters, because high signal field intensity is necessary for such service with the consequent requirement of quite high transmitter power output which is difficult to develop with very low tube efficiency.

However, it is possible to reduce the effects of the interelectrode capacity by the use of a capacity bridge.

One example of a capacity

bridge arrangement in a radio-frequency circuit is the Miller tube capacity neutralizing circuit. This is shown schematically in Fig. 13,

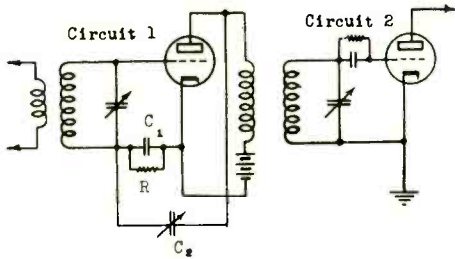

Fig. 13.—Miller tube capacity neutralizing circuit.

and in the form of the equivalent capacity bridge circuit in Fig. 14.

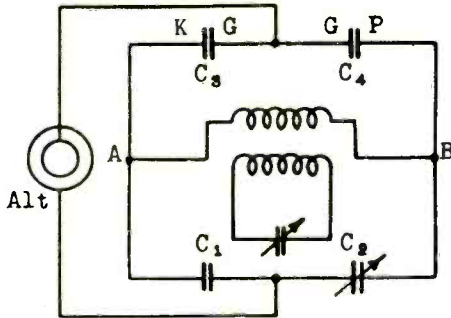

Fig. 14.—Equivalent bridge circuit for tube capacity neutralizing circuit.

In Fig. 13 the grid-to-plate capacity of the tube and the grid-to-cathode capacity of the tube form two arms of the bridge, C_1 and C_2 form the other arm.

In Fig. 14, C_3 represents the grid-to-cathode tube capacity, and C_4 represents the grid-to-plate capacity of the tube. C_1 corresponds to C_1 in Fig. 13; C_2 corresponds to C_2 in Fig. 13. The alternator, ALT, corresponds to Circuit 1 in Fig. 13 and is the driving volt-

age of the bridge. Circuit 2 in Fig. 13 is represented by the circuit between points A and B in Fig. 14.

An inspection of Fig. 14 shows plainly that it is a capacity bridge and operates on the bridge principle of divided voltages across a split circuit. Since the two capacities of the tube form two arms of the bridge, it is merely necessary to add two small capacities, C_1 and C_2 , to form the other two arms. The bridge is balanced when

$$C_1 : C_2 :: C_3 : C_4$$

Under this condition there is no voltage across Circuit 2 except when the tube is amplifying. Since C_1 , C_3 , and C_4 are fixed, it is simply necessary to adjust C_2 until the correct ratio is obtained, just as the variable arm of a Wheatstone bridge is adjusted for a zero reading in the galvanometer.

In Fig. 13 the only function of R is to provide a direct current leak between the grid and cathode to prevent the tube from blocking. This particular circuit has been used quite extensively in high-frequency receivers.

RESUME'

This concludes the assignment on triode tubes. It has been shown that the grid has a more profound effect upon the plate current flow than the plate voltage itself; a one-volt negative change in grid potential may counteract, in a particular tube, a 20-volt increase in plate potential, so that the plate current remains unchanged. The tube is said to have an amplification

factor of 20.

The relation between plate current and grid and plate voltages may be plotted in three ways. Of these, the one most often used is a 'family' or group of curves showing in any one curve how the plate current varies with plate voltage, while the grid voltage is maintained constant for that particular curve. For another $i_b e_b$ curve, the grid voltage is held constant at another value, and so on for the whole family of curves.

In another family, the plate voltage is kept constant at one value or another, and curves are obtained showing the relation between i_b and e_c , one for each value of e_b . As will be shown in a succeeding assignment, the former family of curves is more useful in solving amplifier problems and the like.

The triode (and other multi-element tubes) can be compared with regard to certain ratios known as tube factors or parameters. One has been indicated above, namely—the amplification factor. Another is

the internal plate resistance of the tube; reference is usually made to the a-c or dynamic plate resistance, which refers to the ratio of the change in plate voltage to the corresponding change in plate current, with the grid voltage held constant.

A third ratio is that known as transconductance. This is the ratio of change in plate current produced by a change in grid voltage, with the plate voltage held constant. As will be seen from subsequent assignments, this is one of the most important tube factors, and acts as a 'figure of merit' for the tube; i.e., it indicates the relative superiority of one tube over another.

Finally the interelectrode capacitances of the tubes are of importance, particularly at the higher frequencies. The grid-to-plate capacitance is of a special importance; depending upon the 'gain' or amplification of the stage, this capacity may appear many times as large as it actually is, to a source supplying signal to the grid of the tube.

TRIODE TUBES

EXAMINATION

1. (a) In a triode tube, if the grid is made less negative the space charge will (increase, remain the same, decrease).
(b) In a triode tube, if the grid is made less positive the plate current will (increase, remain the same, decrease).
2. (a) In a triode tube, if the grid is made more positive the d-c plate-to-cathode resistance will (increase, remain the same, decrease).
(b) Grid current will flow in a triode when the grid is (at cathode, at a positive, zero) potential with respect to the cathode.
3. (a) Consider a triode in normal operation. If the plate voltage is decreased by 2 volts and the grid voltage is made 2 volts less negative, the plate current will (increase, remain the same, decrease).
(b) In any vacuum tube the number of electrons leaving the cathode at any instant is the (same as, greater than, less than) the number of electrons returning to the cathode.
4. (a) Consider a triode with fixed cathode-plate spacing. As the grid is moved closer to the cathode the amplification factor will (increase, remain the same, decrease).
(b) In normal operation of a triode tube (with proper load in plate circuit), when the grid goes positive the plate current will (increase, decrease, remain the same).
5. (a) Consider a triode with fixed cathode-grid spacing. As the plate is moved further away from the cathode the amplification factor will (increase, remain the same, decrease).
(b) Under the condition of 5(a) the cathode-to-plate resistance will (increase, remain the same, decrease).
6. (a) What is an $i_b e_b$ curve and what is the practical value of such a curve?

TRIODE TUBES

EXAMINATION, Page 2.

6. (b) What is the difference between static and dynamic curves?

7. (a) Explain the cause of the upper bend in the $i_b e_c$ curve.

TRIODE TUBES

EXAMINATION, Page 3.

8. (a) R_p is the ratio of a small change in (e_b, e_c, i_b, i_c) to a small change in (e_b, e_c, i_b, i_c) with (e_b, e_c, i_b, i_c) constant.
- (b) G_m is the ratio of a small change in (e_b, e_c, i_b, i_c) to a small change in (e_b, e_c, i_b, i_c) with (e_b, e_c, i_b, i_c) constant.
- (c) μ is the ratio of a small change in (e_b, e_c, i_b, i_c) to a small change in (e_b, e_c, i_b, i_c) with (e_b, e_c, i_b, i_c) constant.
- (d) G_m is equal to $(\mu R_p, R_p/\mu, \mu/R_p)$.
9. (a) Reference Fig. 15. What is the proper grid bias for Class A operation?
- (b) With the proper bias what is the greatest R.M.S. excitation voltage that the tube will handle if grid current is not permitted to flow during any part of the input cycle?

TRIODE TUBES

EXAMINATION, Page 4.

9. (c) If plate current cutoff is obtained at approximately (E_p/μ) grid volts, what is the approximate μ of the tube?
10. Reference Fig. 16. Tangent lines have been drawn at two points to assist the student in solving this problem.
- (a) Calculate R_p at $e_b = 250v$ and $e_c = -2v$.
- (b) Calculate μ at $e_b = 250v$ and $e_c = -2v$.
- (c) Calculate G_m at $e_b = 250v$ and $e_c = -2v$.

TRIODE TUBES

EXAMINATION, Page 5.

10 (d) Calculate R_p at $e_b = 250\text{v}$ and $e_c = -3\text{v}$.

(e) Calculate μ at $e_b = 250\text{v}$ and $e_c = -3\text{v}$.

TRIODE TUBES

EXAMINATION, Page 6

9. (Continued)

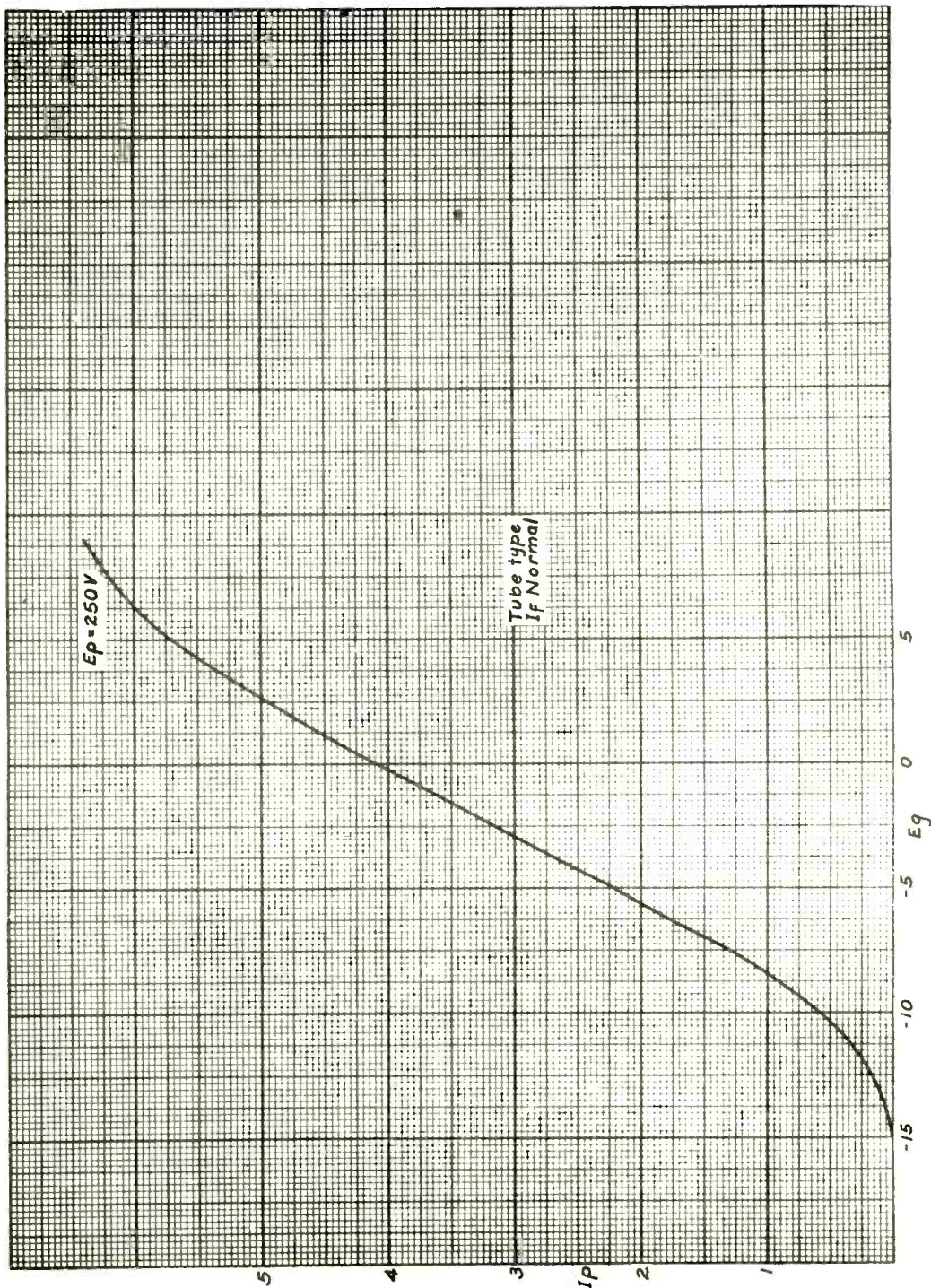

Fig. 15

TRIODE TUBES

EXAMINATION, Page 7

10. (Continued)

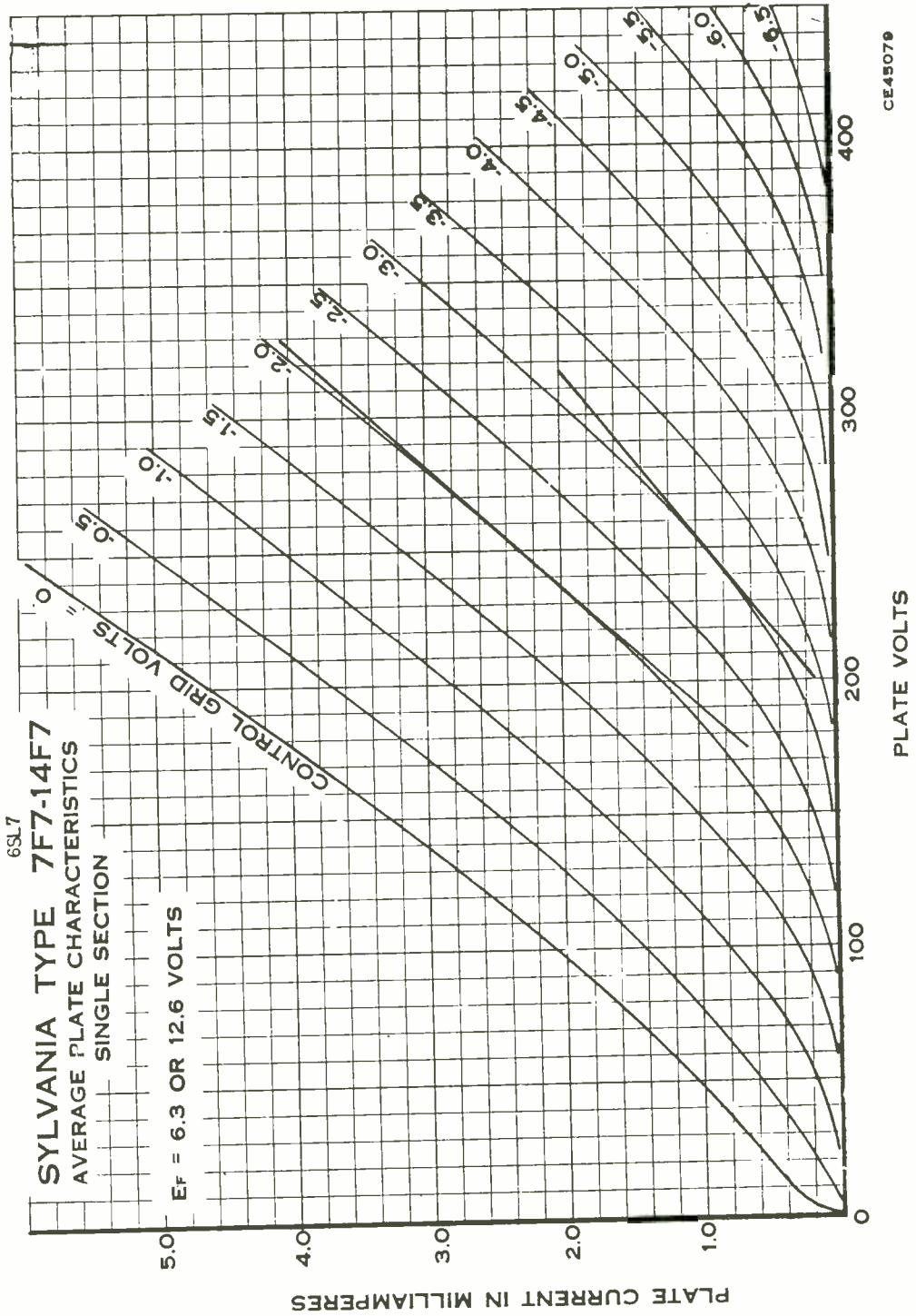

FIG. 16

