

621.38
W527

WESTERN
UNION

Technical Review

RECEIVED

JUN 1 1948

WESTERN UNION R. P. I.

R. P. I.
LIBRARY

**Concentrated-Arc
Lamp**

•

**Carrier System for
Radio Relay**

•

**Tunable Rejection
Filter**

•

**Western Union
Switching Systems**

**VOL. 2
APRIL**

**NO. 2
1948**

WESTERN UNION TECHNICAL REVIEW

VOLUME 2 . Presenting Developments in Record Com- . A P R I L
NUMBER 2 . munications and Published Primarily for . 1 9 4 8
Western Union's Supervisory, Maintenance and Engineering Personnel.

CONTENTS

	PAGE
THE DEVELOPMENT OF THE CONCENTRATED-ARC LAMP <i>W. D. Buckingham</i>	47
A 150 KC CARRIER SYSTEM FOR RADIO RELAY APPLICATIONS <i>J. E. Boughtwood</i>	57
A TUNABLE REJECTION FILTER <i>R. C. Taylor</i>	66
THE DEVELOPMENT OF WESTERN UNION SWITCHING SYSTEMS <i>R. F. Blanchard and W. B. Blanton</i>	75

Published Quarterly by

THE WESTERN UNION TELEGRAPH COMPANY

COMMITTEE ON TECHNICAL PUBLICATION

P. J. HOWE, Development and Research Dept., *Chairman*
F. B. BRAMHALL Development and Research Dept.
I. S. COGGESHALL Internat'l Communications Dept.
W. H. FRANCIS Plant and Engineering Dept.
G. P. OSLIN Public Relations Dept.
S. N. PHILLIPS Commercial Department
M. J. REYNOLDS Patent Department
H. M. SAUNDERS Traffic Department

NELL ORGAN, *Secretary*

Address all communications to the Committee on Technical Publication,
THE WESTERN UNION TELEGRAPH Co., 60 Hudson St., New York 13, N. Y.

SUBSCRIPTIONS \$1.50 per year

PRINTED IN U.S.A.

(Copyright 1948 by The Western Union Telegraph Company)



PUSH-BUTTON SWITCHING INSTALLATION AT PHILADELPHIA, PA.

This latest adaptation of reperfector switching, in which push-button operation supersedes plug and jack operation, will be described in a subsequent issue of TECHNICAL REVIEW.

The Development of the Concentrated-Arc Lamp

W. D. BUCKINGHAM

Condensed from a paper presented before the New York Electrical Society on October 22, 1947

Early in 1939, the Western Union Telegraph Company started an investigation to determine the communication possibilities of that part of the electromagnetic spectrum which is higher in frequency than the shortest radio waves.

A study of atmospheric transmission characteristics, as well as the radiant energy sources and detectors then available, pointed to the wave-length band between 0.3 and 1.5 microns, or millionths of a meter, as the most promising. This band covers the visible spectrum, together with the adjacent ultraviolet region down to the transmission limit of ordinary glass, and the infrared region out to the long-wave threshold of photoelectric detectors. Theoretically, it would have been advantageous to work farther down in the infrared, but there were no suitable infrared generators or detectors.

Even in the wave-length region chosen, there was no radiant energy source which was ideally suited for light-beam communication purposes. The light output of the various glow, crater and gas-discharge lamps could be modulated at audio frequencies by modulating the lamp current but the intensity of these lamps was low. Stable high-intensity sources, such as tungsten-filament lamps, could not be modulated except by valves or shutters outside of the lamps. The ideal source seemed to be one which could be modulated without the use of light valves, and which, at the same time, would be of high intensity and have long life and stable position characteristics. Also, from the standpoint of economy of energy and the required secrecy characteristics of narrow-beam transmission, the transmitting source should be very small in size.

The search for such a light source led into the field of gas-discharge lamps and finally concentrated on the cathode-glow

region of an arc, operating between tungsten electrodes which were sealed into a bulb filled with an inert gas at about atmospheric pressure. Under these conditions, a brilliant spot of light is formed at the point where the arc stream strikes the cathode or negative electrode. This spot of light had the advantages of high brightness, small size and good modulation characteristics, but it would not remain fixed in position.

Some improvement in spot stability was obtained by using a pointed tungsten wire for the cathode. With this construction, the brilliant cathode spot would form on the sharp point of the electrode for several minutes at a time, but eventually it would wander off to other parts of the cathode. An attempt was then made to insulate all except the sharp tip of the negative electrode so that the arc could strike to no other point. A number of refractory ceramic materials were tried for this purpose, but they were unsatisfactory because they could not withstand the extreme heat of the arc discharge.

Finally, a very refractory material, zirconium oxide, was tried. When this lamp was tested, it was found to work very well at first but, after a few minutes of operation, the cathode spot left the tungsten electrode and wandered over to the surface of the zirconium oxide which surrounded the tungsten. There it apparently fused the surface layer of the oxide and produced a tiny circular spot of light only a few thousandths of an inch in diameter and many times more brilliant than the spot previously formed on the tungsten. This spot moved around slowly on the fused zirconium surface. When the lamp was reignited, after being allowed to cool, the arc struck directly to the fused oxide surface and could not be made to return to the tungsten. Apparently the

oxide had been conditioned by the action of the arc so that it would now hold the cathode spot better than the tungsten.

The obvious move was to reverse the position of these two elements; that is, to put the zirconium oxide in the center of the cathode where it would hold the cathode spot, and to surround it with a tungsten tube so that the spot could not wander off of the central core. When a potential was applied to such a lamp, shown in Figure 1, the arc struck at first from the anode to the tungsten side wall of the cathode but after a few seconds the intensely bright spot of light formed on the oxide core and remained there. Since the new lamp produced a spot of light which was very small, extremely bright and sharply defined, it was called the Concentrated-Arc Lamp.

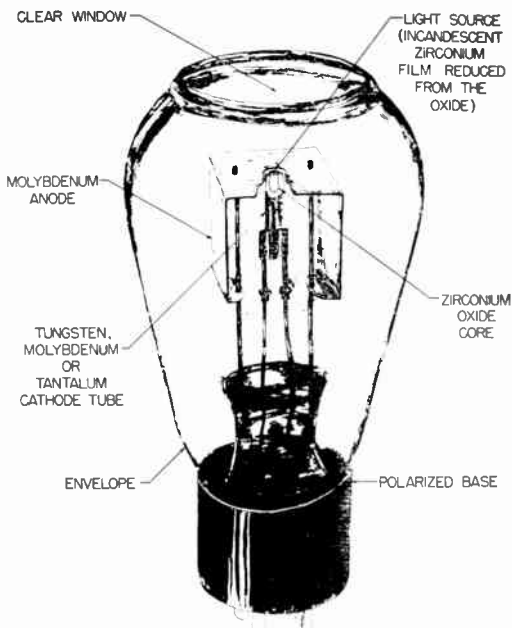

Figure 1. Concentrated-arc lamp—cut-away view

Tests on the new lamp showed that its light could be modulated up to high audio frequencies by modulating the arc current. This apparently was the type of lamp which was being sought, but it required about a quarter of an ampere for its operation and this was thought to be

too much for the proposed application. The problem was to produce a similar but smaller lamp.

Very small bore tungsten tubing was not available, so a smaller concentrated-arc light was finally made by drilling a hole 0.004 of an inch in diameter and about 0.020 of an inch deep in the end of a tungsten wire which was 0.020 of an inch in diameter, and filling the hole with zirconium oxide. As tungsten is a rather hard material, this hole was produced by grinding, using diamond dust on a 0.003 inch diameter tungsten wire as a drill. This was a slow process but it did result in excellent lamps which operated on two watts and had a luminous spot with a diameter of only 0.003 of an inch.

At about this time, the Western Union received from the National Defense Research Committee a contract which had as its object the development of concentrated-arc lamps in larger sizes and their production in large quantities. Under this contract, several thousand lamps, in 2, 10, 25 and 100-watt sizes, were manufactured, using a simplified method for forming the cathodes.

The improved process for making cathodes consists of packing a short, thin-walled tube of tantalum, which is about a quarter of an inch in diameter, with zirconium oxide. The tube is then drawn through a series of wire drawing dies which reduce its diameter to a few thousandths of an inch, thus forming a long piece of small-diameter zirconium-oxide-filled tantalum tubing. Tantalum is a metal with a very high melting point; it is not quite as refractory as tungsten but is much more ductile and can be easily machined and drawn. The tubing is then cut into short lengths which are mounted as cathodes in the lamps. The original piece of tantalum rod which was two inches long is thus worked into an oxide-filled tube over 40 feet long, sufficient for cathodes for 1300 2-watt concentrated-arc lamps.

The positive electrode or anode is made of a metal which has a high melting point and consists of a simple sheet or plate, with sufficient radiating surface to permit operation at no more than a dull red heat.

The two electrodes are mounted in a bulb so that the exposed oxide surface of the cathode is but a few hundredths of an inch from and directly behind a hole in the center of the anode. This hole is slightly larger in diameter than the cathode tube and provides a window for the emergence of light from the cathode.

After the bulb has been evacuated, it is filled with an inert gas, usually argon, to almost atmospheric pressure. The cathode is then put through a "forming" process. To do this, a high-potential direct-current source, with suitable current-limiting resistors in series, is connected to the electrodes so that an arc strikes between the anode and the metallic tube of the cathode. After a few seconds, the cathode tube becomes red hot and heats the zirconium oxide packed in it to a temperature where the oxide becomes electrically conductive. The arc then strikes between the anode and the oxide, and the ionic bombardment of the arc raises the temperature of the surface of the oxide to or above its melting point of about 5000° F. In the molten state and under the intense ionic bombardment of the arc, some of the zirconium oxide is reduced to metallic zirconium.

Zirconium metal is a better electron emitter at high temperatures than is the oxide and it also has a lower melting temperature; thus as soon as a thin surface layer of zirconium is formed, the temperature of the cathode drops slightly and the underlying oxide solidifies and supports the thin film of molten zirconium metal on its surface. It is this film of molten metal which is the chief source of the visible radiation from the lamps. The film, once formed during manufacture, becomes heated and incandescent whenever the lamp is relighted. It is so thin that surface tension holds it to the oxide backing, permitting the lamps to be burned in any position.

Spectrograms of the portion of the arc stream very near the cathode always show zirconium lines. This indicates that some evaporation of free zirconium occurs, but very little is lost, since positive zirconium ions are produced by electron bombardment and are drawn back to

the cathode. If any metal atoms do escape from the cathode, they are replaced by reduction of the underlying oxide. As a result of these processes, the lamps have lives which are measured in hundreds of hours.

Thus, concentrated-arc lamps are quite different from any other source of light. They offer several unique advantages. They produce a very high-intensity light source in the form of a luminous circular spot which is fixed in position, sharply defined and uniformly brilliant. Their brightness may be as much as 65,000 candles per square inch, which is ten times that of the incandescent wire in the ordinary tungsten filament lamp. The light source may be as small as 0.003 of an inch in diameter or, in higher wattage lamps, as large as several tenths of an inch. The emitted light is a brilliant white, whose color temperature changes but little during the life of the lamp, which may exceed 1000 hours. When the current through the lamp is modulated at audio frequencies, a substantial part of the radiation also is modulated.

A line of standard-size lamps has been developed in sizes ranging from 2 to 100 watts. Pictures of these lamps are shown in Figure 2.

The lamps are started with a high voltage which breaks down the gap between the electrodes. They are usually run from one of the special power units which have been made for them, or from a rectifier or direct-current generator or battery with sufficient ballast resistance in series to limit the current to its normal value.

The unique characteristics of concentrated-arc lamps led to their use in a variety of applications during the war and have led to many more since. The earlier applications used the concentrated-arc lamps as point sources of light, without optical accessories. There is, of course, no such thing as a true point source, but the smaller sizes of concentrated-arc lamps are a close approach to one. Many interesting and useful things can be done with them.

Since the light rays radiate from what is almost a single point, the lamps can be used as lensless enlargers to throw very

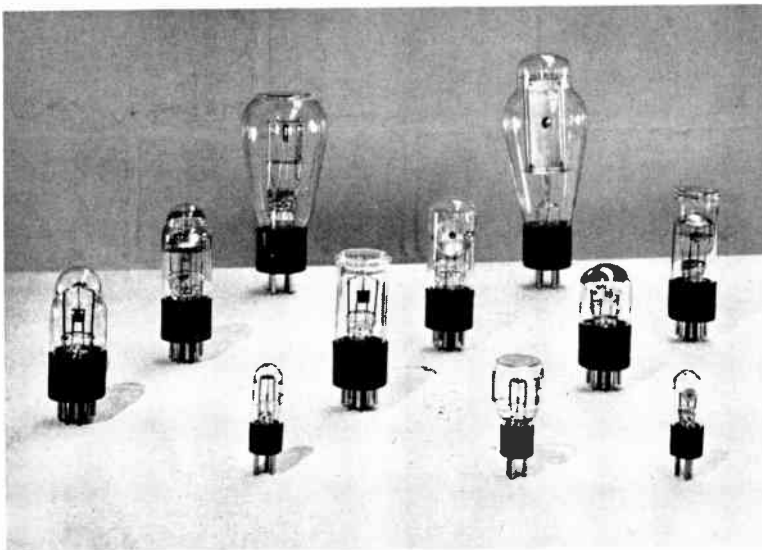

Figure 2. Various types of 2, 10, 25 and 100-watt Concentrated-arc lamps

sharp shadows, as shown by the shadow of the dragon fly on a pin in Figure 3. The fly can be seen in the lower corner of the picture. The shadow is projected on the wall with considerable enlargement, but even so each detail stands out clearly. A simple line drawing on a transparent plate can be magnified with considerable fidelity with the point source lamp alone. This makes the lamp particularly useful



Figure 3. Shadow projection with a "point-source" 2-watt Concentrated-arc lamp

for distorted view of maps as seen in Figure 4.

During the war, the Office of Strategic Services used concentrated-arc lamps for the reverse of this operation. Aerial photographs which had been taken at an angle to the surface of the earth were rectified by projecting them at the same angle on to a horizontal screen with the point source lamp. On the image thus projected, the true size, shape and position of the various objects on the ground could be measured as accurately as from a map. The lamps also found wide use in various



Figure 4. Shadow projection with a 10-watt Concentrated-arc lamp

training devices. They were used for the lensless projection of landscapes, seascapes, and cloud formations, and to produce silhouettes of model planes, battle-ships and tanks.

Another war application of these point-source lamps was in a boresighter, a device which is used to check and adjust the sights on guns. The light-beam boresighter consists of a 2-watt concentrated-arc lamp mounted on the axis of a tube behind a lens so that the image of the point source is projected along the axis of the device. When this unit is fixed in the barrel of a gun, the projected beam traces accurately the path which would be followed by a bullet, fired from that gun.

A small concentrated-arc lamp is an excellent point source of light with which to test lenses, adjust optical devices, and demonstrate lens aberrations and other optical phenomena.

A second broad field of application of concentrated-arc lamps is their use as the source of illumination in optical systems. Figure 5 shows a point source at the principal focus of a condensing lens. Since the light source is so small, the rays leaving the lens are almost exactly parallel. Such

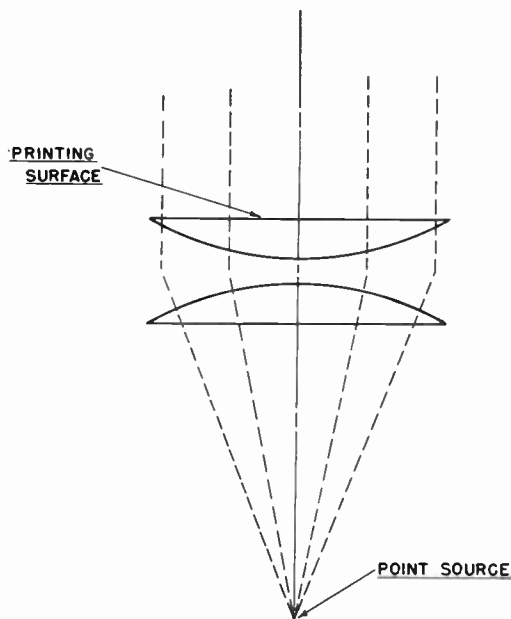
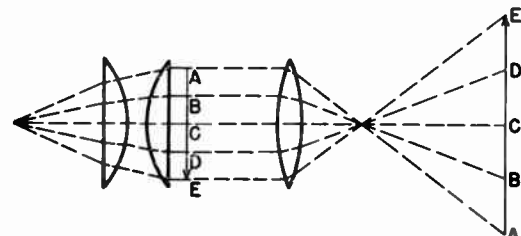

Figure 5. Parallel light rays from a point source, through a lens

CONCENTRATED-ARC LAMP

an arrangement makes an unusual contact printer for photography, in which close contact between the negative and print is not necessary.

Figure 6-a pictures a photographic enlarger, in which the point source is placed



a—Light source at focal point of condenser.

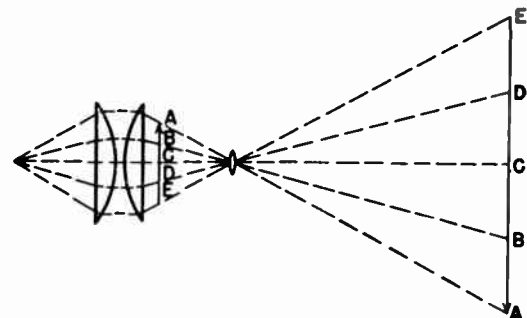

b—Light source positioned so rays converge to enlarging lens.

Figure 6. Theoretical photographic enlarger with point-source illumination

at the focal point of the condensing lens, so that the light rays leave the condenser substantially parallel. Thus, the ray passing through point "A" on the negative or film strikes the enlarging lens at only point "A" on the lens and passes through the lens to form the image on the screen. The same sequence is followed by the rays passing through every other point of the film. The important fact is that there is little scattering of the rays at the film, so that light from each microscopically small element of the film passes through only one equally small area of the lens. Thus for each elementary area, the lens acts as if it were stopped down to an extremely small aperture, $f200$ or less, and forms an image having the extreme sharpness and depth of focus that correspond to such an aperture, but there is not the corresponding loss of light, since the whole lens is working.

In practical operation, it is seldom possible to use an enlarging lens as large as the negative, so it is usual to position the light source with reference to the corresponding lens as shown in Figure 6-b. With this arrangement, the light rays converge, in leaving the condenser, but the stopping down effect is the same as previously described. The unusual definition obtained with point-source lamps is



a—Photograph enlarged with standard lamp in enlarger.



b—Photograph enlarged with 25-watt Concentrated-arc lamp in enlarger.

Figure 7.

illustrated by the photographs of Figure 7, which show the comparative results obtained from a photographic enlarger equipped with a standard 150-watt tungsten photo-enlarging lamp, and the same enlarger using a 25-watt concentrated-arc lamp.

The increased sharpness and depth of focus that result from the use of point-source lamps in photographic enlargers are also secured in many other optical devices, when point-source lamps are substituted for the large lamps normally employed. In microscopy the results are quite marked, as shown by the photomicrographs of Figure 8. Other advantages of concentrated-arc lamps for microscope illumination lie in the reduced heating of the specimen and the increased quantity of light which is put through the microscope. It has been found possible to obtain an increase of seven times in the light through a microscope when a concentrated-arc lamp is used in place of the tungsten-ribbon-filament lamp commonly used for this purpose.

Figure 9 diagrams a simple projector system. The problem in many such systems is to get the maximum amount of light through a small opening such as the film gate, and on through the projection lens to the screen. Optically, the way to get maximum light through a small opening is to image the source at that opening. The upper view of Figure 9 shows a projector using a concentrated-arc lamp source adjusted to this condition. Since the concentrated arc has a uniformly brilliant disc of light, its image, when placed at the film gate, results in a uniformly illuminated screen.

This adjustment cannot be used when a tungsten-filament projection lamp is employed. In this case, the projector must be set up, as shown in the lower part of Figure 9, so the coils of hot tungsten are imaged not at the film gate but in front of the projection lens. If they were imaged at the film gate, the image of the hot coils would appear on the screen. Since so much light is lost at the gate under the adjustments necessary with tungsten-filament lamps, the efficiency of transferring light to the screen is low.

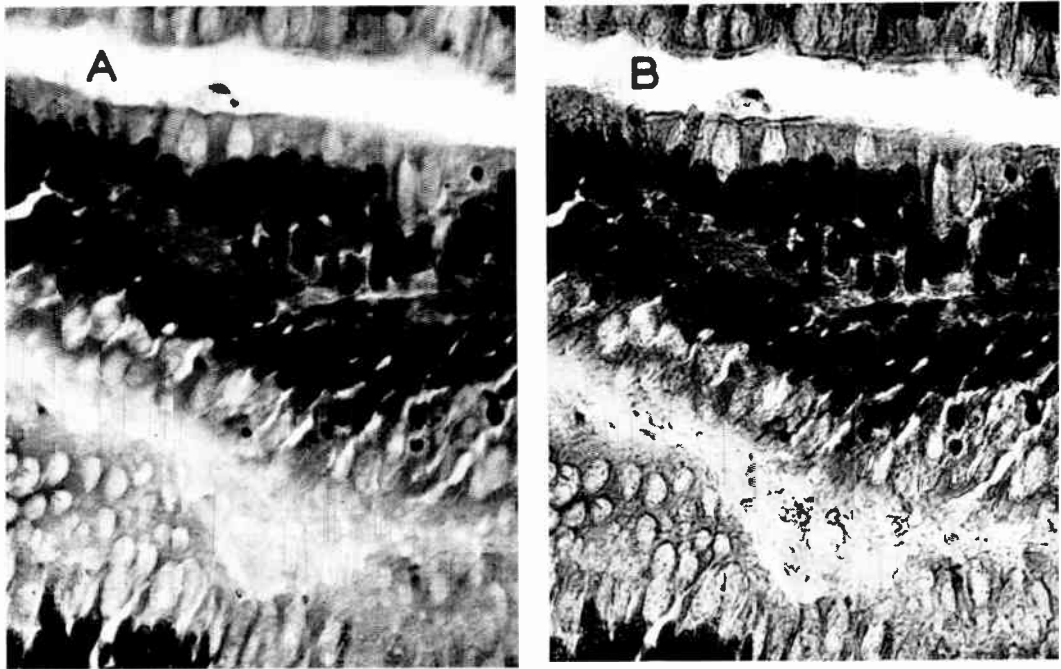

Figure 8. Photomicrographs illustrating the increased detail rendition and depth of field made possible by the concentrated arc in B, as compared with conventional illumination in A.

Thus, concentrated-arc lamps are much more efficient in such projector systems.

A second factor in favor of the concentrated arc in projection systems is that the screen brightness depends upon the source brightness. Since the new lamps are brighter than tungsten-filament lamps,

they show a gain from this standpoint, also. As a practical result of these advantages, a recent test showed that a 100-watt concentrated-arc lamp would put more lumens on the screen through an 8-millimeter film projector than could be obtained when a 500-watt tungsten-filament type projection lamp was used.

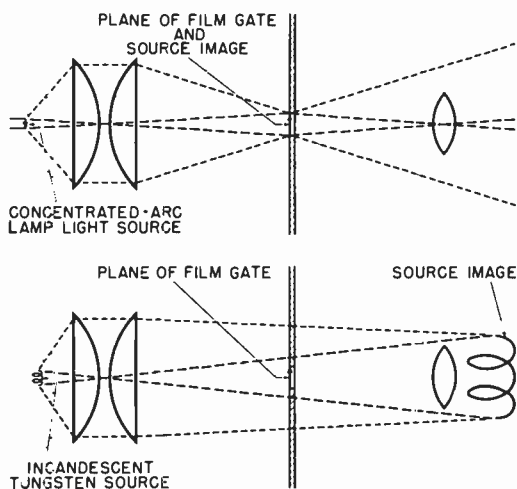

Figure 9. Projection systems with Concentrated-arc lamp (top) and with tungsten-filament lamp (bottom)

Concentrated-arc lamps also find application in the solution of special problems in the field of illumination. An example of such an application is shown in Figure 10. This is an operating lamp designed for a surgeon who is famous for an operation on the inner ear. Since the doctor is working on an object about the size of a grain of wheat, located at the bottom of a small hole cut in the patient's head, he requires a very high level of illumination on the small operating area. His original operating lamp was somewhat similar in design to the one shown but it employed six 250-watt tungsten-filament projection lamps. It was necessary to place the unit only fourteen inches above the patient's head in order to obtain sufficient light. Thus placed, the unit produced 7000 foot-



Figure 10. Special operating lamp, using Concentrated-arc lamps

candles on the operating area but with so much heat that it could be used only intermittently, with a foot switch control. The new unit contains six 100-watt concentrated-arc lamps. It is placed some 30 inches above the operating table and delivers 15,000 foot-candles with so little heat that it can be used continuously.

Another special application of concentrated-arc lamps is their use in the processing of photographs in color and the taking of colored motion pictures. The advantage of the new lamps for these purposes lies in their high and constant color temperature.

All of the applications of the concentrated-arc lamps discussed in the foregoing are outside of the fields for which the development of the lamp was originally undertaken—namely, applications which utilize their modulation characteristics. Such fields of use range from light-beam communication to facsimile pickup and recording and the recording of sound on film.

During the war a 2-watt concentrated-arc lamp was used in the portable infrared light-beam telephone equipment shown in Figure 11. The unit shown served as a combined transmitter, re-

ceiver, and aiming telescope. This equipment had a clear weather range of about six miles. Larger units were developed which employed 25 and 100-watt concentrated-arc lamps.

The original purpose behind the development of the concentrated-arc lamp was its possible use in the telegraph service. Since April 1943, an experimental light-beam telegraph circuit using concentrated-arc lamps as the source of the modulated radiation has been in operation over lower Manhattan. The circuit runs from the main Western Union office at 60 Hudson Street to a branch office in the New York Post Building at 75 Washington Street, an air-line distance of about three-quarters of a mile. A teleprinter-telegraph circuit operating at 65 words per minute is carried by two light-beam systems, one operating in each direction.

Figure 12 shows the light-beam transmitting and receiving equipment at one end of this circuit. This equipment operates unattended. It is started and turned off from the circuit-operating positions and requires only occasional attention.

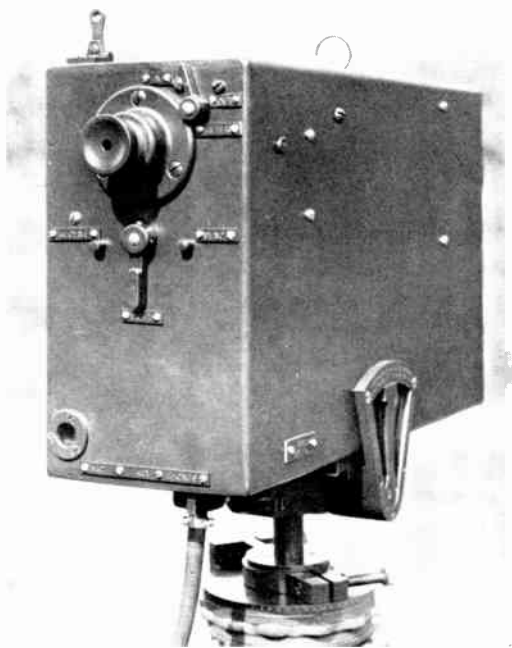

Figure 11. Light-beam telephone transmitter-receiver unit using Concentrated-arc lamp

A concentrated-arc lamp sometimes lasts as long as six months in this service.

A view of the appearance of the distant transmitter from the receiver is given by Figure 13. To the camera and to the eye, the distant transmitter appears to be many times its true diameter because of its extreme brilliance. The light beam is so narrow that if the camera were moved but a few feet in any direction from the center of the incident beam, the spot of light would disappear.

If the transmitter lens on this circuit were absolutely perfect and the atmosphere absolutely clear, there would be a signal loss caused by the spreading of the beam, which would amount to 17 db. Calculations indicate that under ideal conditions this system should operate up to about 30 miles. Under actual conditions, the additional loss due to lens imperfections and atmospheric conditions may be considerable. On a very clear night the received signal on the experimental light-beam circuit is 56 db above the noise level. In daylight, the noise increases so that the signal is 50 db above the noise. Sunshine, clouds, and light haze have

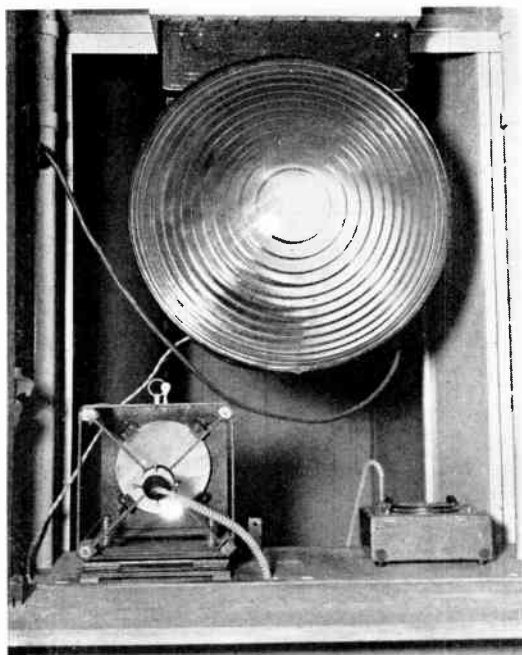

Figure 12. Light-beam transmitting and receiving equipment used on experimental circuit over New York City



Figure 13. View of distant light-beam transmitter from the receiver at New York main office

little effect, although heat waves or striae in the air may cause some fluctuation of the received signal. A light rain may cause the signal to drop 10 db and a very heavy rain 20 db. A moderate fog may reduce the received signal 30 db while a very heavy fog or snowstorm will interrupt the circuit.

During the several years that this circuit has been under test, it has operated 96.7 percent of the time. Of the 3.3 percent lost time, 2.8 percent was due to trouble in the equipment on the light-beam section of the circuit. The remainder of the lost time, or 0.5 percent, was caused by interruptions to the light beam by fog, heavy snow storms and smoke. Ordinary atmospheric haze caused no interruptions, for the near-infrared radiation in the beam pierces this type of diffusing medium better than visible light. The attenuation due to fog is very great and in dense fogs it is impossible to produce a beam of radiant energy from a concentrated-arc lamp which will operate a light-beam communication circuit for more than a few tenths of a mile.

It is concluded from these tests that such circuits can be employed over short distances with good dependability. Long-distance circuits, limited only by the opti-

cal range, should be possible in fog-free localities.

Since the war there have been two major advances in the development of the concentrated-arc lamp. The first is the extension of the line of standard lamps to

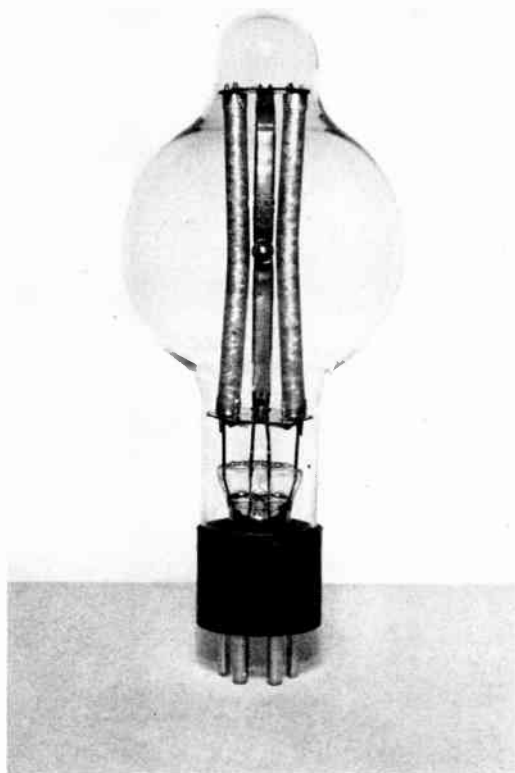

Figure 14. 300-watt Concentrated-arc lamp

THE AUTHOR: W. D. Buckingham, shortly after graduating from the Case Institute of Technology in 1925, became associated with Western Union as an Engineering Apprentice in the Traffic Department at Toledo, Ohio. At the completion of this training course in 1927, he was transferred to the Water Mill Laboratory, where he has been active in applying electronic techniques and equipment to land-line and cable devices. He was responsible for the development of new cable-balancing techniques involving the cathode ray oscilloscope, and for new cable artificial-line construction. The principles thus developed were applied to the rehabilitation of the Alaska Communications System for the Signal Corps. Mr. Bucking-

ham's fundamental work on frequency standards found application in cable photo transmission between London and New York during the War, and on facsimile circuits where terminals were too far apart to permit synchronization by use of interconnected power systems. His most outstanding achievement was the invention of the extremely brilliant point-source zirconium lamp which is finding application in many diverse fields.

include sizes up to 1000 watts. A 300-watt lamp is shown in Figure 14. The second development is the use of hafnium oxide instead of zirconium oxide as a cathode-filling material. Many materials were tested during the early development of the lamp, among them hafnium oxide. At that time, however, pure hafnium oxide was difficult to obtain and commercial lamps were limited to zirconium oxide. Recently 98% pure hafnium oxide has been produced. Lamps made with this oxide are about twice as bright and modulate twice as well as those made with zirconium oxide. The high price of hafnium oxide, however, will probably limit its use to small concentrated-arc lamps of 100 watts or less, at least for the present.

It is hoped that this new high brightness will make the lamps even more useful and that the Western Union's concentrated-arc lamp, although originally developed for the specialized purpose of light-beam communication, will continue to aid in the solution of problems in many fields of science and industry.

References

- THE CONCENTRATED-ARC LAMP, W. D. BUCKINGHAM and C. R. DEIBERT, *Journal of the Optical Society of America*, Vol. 36, No. 5, May 1946.
- CHARACTERISTICS AND APPLICATIONS OF CONCENTRATED-ARC LAMPS, W. D. BUCKINGHAM and C. R. DEIBERT, *Journal of the Photographic Society of America*, Vol. 12, No. 10, November 1946.
- THE CONCENTRATED-ARC LAMP AS A SOURCE OF MODULATED RADIATION, W. D. BUCKINGHAM and C. R. DEIBERT, *Journal of the Society of Motion Picture Engineers*, Vol. 48, No. 4, April 1947.
- THE CONCENTRATED-ARC LAMP IN A LIGHT-BEAM COMMUNICATION SYSTEM, W. D. BUCKINGHAM, C. R. DEIBERT and R. V. MORGENSTERN, *Electrical Engineering*, October 1947.

ham's fundamental work on frequency standards found application in cable photo transmission between London and New York during the War, and on facsimile circuits where terminals were too far apart to permit synchronization by use of interconnected power systems. His most outstanding achievement was the invention of the extremely brilliant point-source zirconium lamp which is finding application in many diverse fields.



A 150 Kilocycle Carrier System for Radio Relay Applications

J. E. BOUGHTWOOD

A paper presented before the Winter General Meeting of the American Institute of Electrical Engineers in Pittsburgh, Pa., January 30, 1948, and reprinted by permission of the A.I.E.E.

Introduction

The Telegraph Company has made extensive use of carrier current systems to increase the message capacity of its wire plant and currently has more than 500,000 telegraph channel miles in operation.¹ These systems have greatly improved the efficiency of traffic handling and have an excellent record for circuit continuity. Nevertheless they are still subject, at times, to interruptions from extraneous electrical disturbances and from physical damage to wire lines.

Rapid wartime advances in microwave radio techniques created new tools for the communications engineer whereby a transmission medium of tremendous intelligence-carrying capacity, and yet economically attractive, could be realized. In cooperation with the Radio Corporation of America, an experimental radio relay system operating in the neighborhood of 4000 mc was developed and placed in operation between New York and Philadelphia with repeaters at Woodbridge, New Brunswick and Bordentown.^{2,3} This circuit, under constant observation since early in 1946, has demonstrated that improved continuity of operation as compared with conventional open wire lines is attainable, subject only to equipment failures at terminals or repeaters. As such failures are amenable to design and maintenance procedures, it appears that nearly the ultimate in reliability can be achieved by the use of microwave radio systems.

The radio relay systems currently being installed to link New York, Washington and Pittsburgh have useful transmission bands extending from 60 cycles to 150 kilocycles. To integrate such systems into

a telegraph carrier plant standardized on a basis of telegraph channel groups designed to occupy fully voice bands approximately 3000 cycles wide, it was necessary to subdivide the 150 kc frequency bands accordingly. Both time division and frequency division methods for accomplishing this result were considered. The somewhat uncertain status of pulse systems as to flexibility and efficiency, where maximum utilization of a restricted frequency spectrum is a major consideration, dictated the use of a single-sideband, frequency-division system as the most practical method for deriving the required voice bands.

General Description

The new carrier system, designated as Type WN, furnishes 32 independent voice circuits and occupies the frequency range between 3.9 and 147.3 kilocycles. Each voice band provides a useful transmission path extending from 300 to 3300 cycles, sufficient to accommodate 18 narrow-band (150-cycle spacing) telegraph carrier channels⁴ or 10 wide-band (300-cycle spacing) channels. Table 1 illustrates the message handling capacity of the system for various modes of operation. Where the four-channel multiplex method is employed, an excellent frequency spectrum efficiency is realized, requiring but 1.7 cycles of spectrum per word minute. Although this tremendous word capacity is quite practical of attainment, it is expected that the teleprinter method will predominate, the reduction in maximum capacity being more than compensated for by other operational advantages thereby achieved.

Type of Operation	Type of Channel	No. of Ckts	Theoretical Capacity in WPM
Teleprinter	Narrow-Band	576	34,600
2-Chan Mux	Narrow-Band	1152	76,000
4-Chan Mux	Wide-Band	1280	84,500

In its fundamental concepts, the WN system is similar to earlier wire systems developed by The Western Union Telegraph Company. By means of tandem group modulators and filters, the load capacity of the system is increased in geometric progression with each succeeding stage of modulation. The advantages of this method are that a minimum number of translation frequencies are involved and grouping filters can utilize coils of nominal efficiencies, rather than the crystal units which would be required if each voice band were raised to its assigned "line" frequency by independent modulator stages. Crosstalk and distortion due to nonlinearities in amplifiers have been reduced to negligible proportions by the use of negative feedback and conservative load ratings. Modulators are of an im-

proved balanced bridge type capable of operating at high signal-to-carrier ratios without appreciable distortion. The required carrier frequencies are derived from a single base frequency oscillator and harmonic generator. A temperature-controlled crystal oscillator and associated electronic regulator circuit stabilize the base oscillator to the desired accuracy.

A simplified system theory diagram is shown in Figure 1 with the corresponding "line" frequency allocation of each voice-band indicated. The pattern of geometric progression is quite evident in the band-frequency chart, and is employed in all but the initial modulation stage. The minimum line frequency of 3.9 kc simplifies to some extent the design requirements of various components and also eases the transmission problems encountered where the radio and carrier system equipment are remote from one another.

Table 2 has been prepared to illustrate the path followed by a given voice band in reaching its assigned line frequency. It shows the frequency translations encountered by a 1000-cycle tone applied to Voice Band 8-C before reaching its ultimate position at 99.8 kc. Five translations

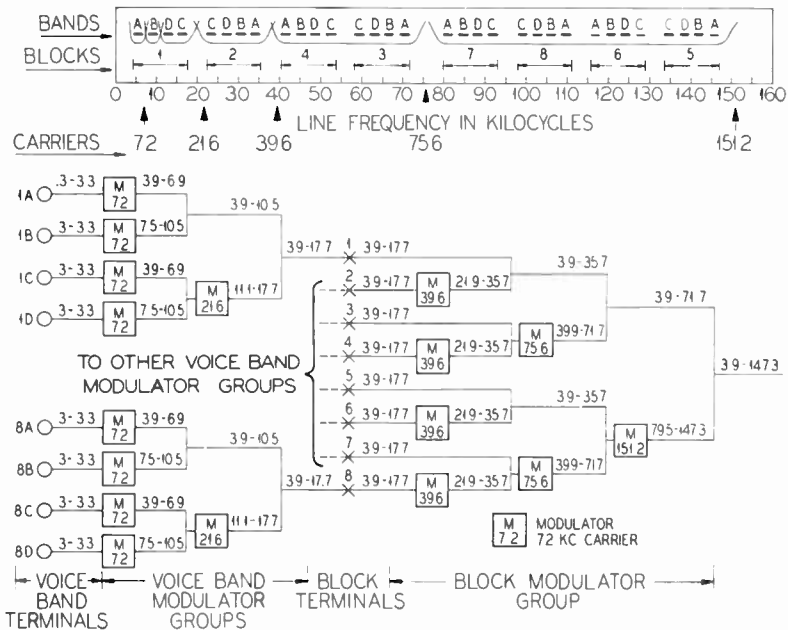

Figure 1. System theory and frequency allocations

are involved and conversely a similar number must be traversed at the receiving terminal before the 1000-cycle tone again appears at the output of Voice Band 8-C. Voice Band 8-D also is subject to five translations,

Table 2

<i>Input Frequency Kc</i>	<i>Translation Frequency Kc</i>	<i>Output Frequency Kc</i>
1.0	7.2	6.2
6.2	21.6	15.4
15.4	39.6	24.2
24.2	75.6	51.4
51.4	151.2	99.8

but in this case the upper sideband of the 7.2 stage is selected and the resulting line frequency is 101.8 kc. Bands 1-A and 1-B are translated but once at each terminal. The remaining bands, of course, fall between these two extremes.

In a communication network comprising a large number of radio relay systems, certain groups of voice bands may encounter several such systems in tandem between point of origin and destination. Traffic dispatching can be expedited and equipment economy realized if these bands are grouped into blocks and each block handled as a single unit. This arrangement has been incorporated in the

system by providing the patching jacks indicated by X on Figure 1. A four voice-band grouping point was selected as the most practical, although the 2, 8 or 16 band points could as readily be made available if desired. Greatly increased system flexibility is achieved as the equipment to the left of the indicated patch points can be moved from one system to another as traffic or emergency conditions dictate. The arrangement also permits voice-band blocks to be cut through intermediate terminals without demodulating each band to voice frequency. As a result, considerable economy in equipment is realized since that portion of the system capacity reserved for spare or cut-through service need not be equipped beyond the block patching point.

The system thus divides itself into two types of modulating equipment; one designated as a Voice Band Modulator Group, to combine four separate voice bands into a single block, and the other as a Block Modulator Group, to combine eight such blocks for transmission over the radio relay circuit.

The general physical appearance of a typical installation, involving two WN system terminals with a common carrier supply group, is shown in Figure 2.

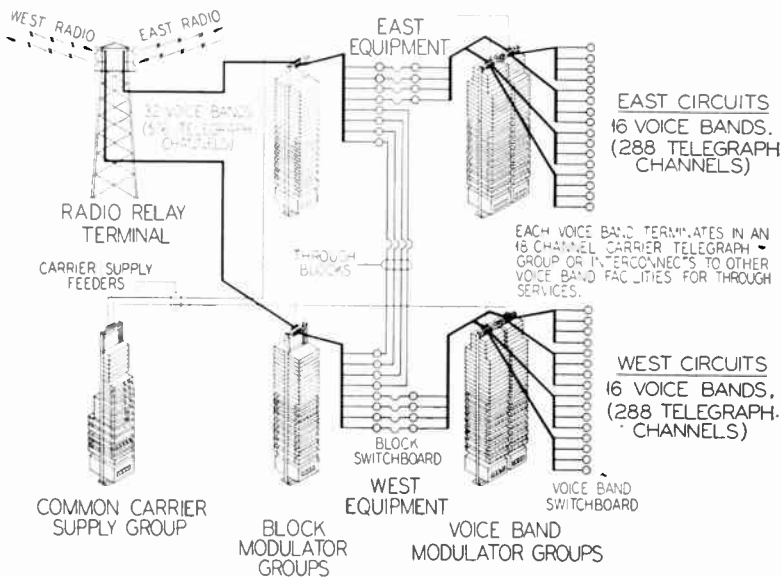

Figure 2. Typical intermediate station involving two radio relay terminals

SYSTEM DETAILS

Voice Band Modulator Group

A voice band modulator group, employed to handle the four individual voice bands which make up a block, is shown schematically in Figure 3. The number of voice band modulator groups associated with a given WN system depends upon traffic requirements. Not more than four groups, occupying two repeater racks and furnishing a total of 16 voice bands, would be normally assigned, leaving half the system capacity available for spare or cut-through service.

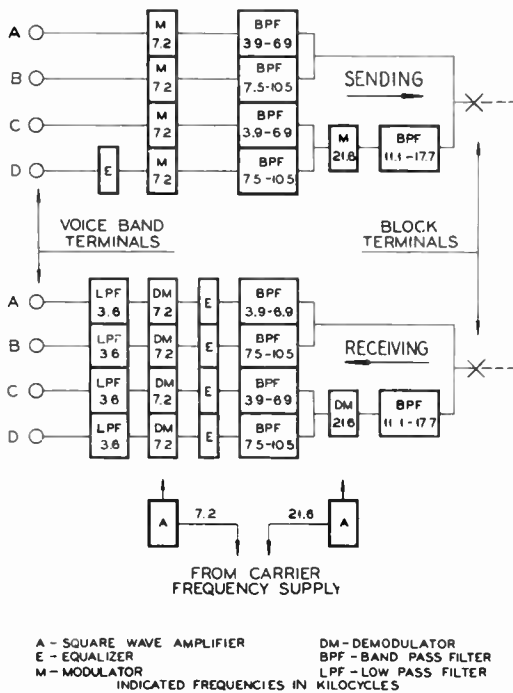

Figure 3. Voice band modulator group

The function of the sending portion of the modulator group is to accept four identical voice bands and arrange them one above the other in the frequency range 3.9-17.7 kc. Each voice band is initially modulated by a 7.2 kc carrier, the lower sidebands of A and C and the upper sidebands of B and D are separately selected by appropriate filters. Since A and C now both lie in the frequency range 3.9-6.9 kc, and similarly B and D occupy the 7.5-10.5 kc region, bands C and D are combined, and again modulated by a 21.6

kc carrier and the lower sideband 11.1-17.7 kc selected. Each voice band now occupies a different part of the spectrum so that all may exist simultaneously at the output.

The receiving portion of the modulator group functions in the converse manner to restore the voice bands to their original frequency location.

Block Modulator Group

The 150 kc transmission band furnished by the radio relay circuit is channelized into eight 3.9 to 17.7 kc blocks by the block modulator group shown schematically in Figure 4. Each block will accommodate one voice band modulator group giving a maximum system capacity of 32 voice bands.

In the "stacking" of the individual blocks, the lower sideband of the modulation process is utilized in all cases. At the sending terminal Block 1 encounters no modulator and reaches the line in its original frequency location. Block 2 is raised to the frequency range 21.9 to 35.7 kc by a 39.6 kc modulator and paralleled

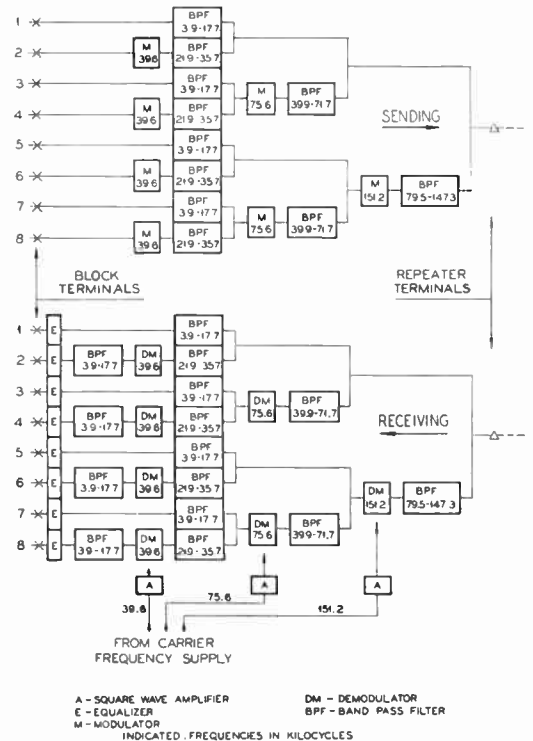

Figure 4. Block modulator group

with Block 1. Blocks 3 and 4 are similarly combined and then translated to the frequency range 39.9-71.7 kc by an additional 75.6 kc modulator before joining Blocks 1 and 2. Blocks 5 to 8 are treated identically and raised to the frequency range 79.5 to 147.3 kc by a final 151.2 kc modulator before reaching the line. Each block now occupies a different portion of the 3.9 to 147.3 kc spectrum for transmission.

The receiving portion of the block modulator group utilizes a similar method in the reverse order to restore each block to its original frequency location.

Modulator Circuits

Much has been published in connection with modulators,⁵ particularly the double-balanced ring type commonly used in

single-sideband, carrier-suppressed systems, shown in Diagram (a), Figure 5. In idealized theory, this modulator is treated as a DPDT reversing switch which operates back and forth at the carrier frequency and whose reversing time is zero. Under this condition, distortion products involving harmonics of the signal are non-existent. In practice, small rectifier elements perform the switching function under control of the applied carrier voltage. For the polarities shown, elements A-A are polarized in the conducting direction and offer a low impedance to the signal currents, while elements B-B are polarized in the non-conducting direction and offer a high impedance to the signal. The output current flows as indicated. When the carrier voltage reverses, the impedance conditions of the rectifiers reverse as does the output signal current. If the rectifier impedances are independent of the signal currents flowing through them, then the equivalent of true switching action can be achieved. However, with a sine wave carrier, there is a definite proportion of time at the crossover when the signaling current is equal to or greater than the carrier and during this interval severe distortion can occur. For this reason, the ratio between carrier and signal powers must be large if distortion in wideband group modulators carrying a multitude of separate signal frequencies is to be maintained at an acceptable level. A logical solution is to employ a square wave carrier voltage which switches the rectifier elements abruptly between the conducting and the non-conducting conditions and reduces to negligible proportions the time interval during which the signal can influence the rectifier impedances. A reduction in distortion components of at least 25 db can easily be achieved by this method.

Another factor which may seriously limit the load carrying capacity of the double-balanced modulator can be explained by reference to the equivalent circuit shown at (b). Idealized rectifiers are assumed having a low resistance R_f when polarized in the conducting direction and a higher resistance R_b when polarized in the non-conducting sense.

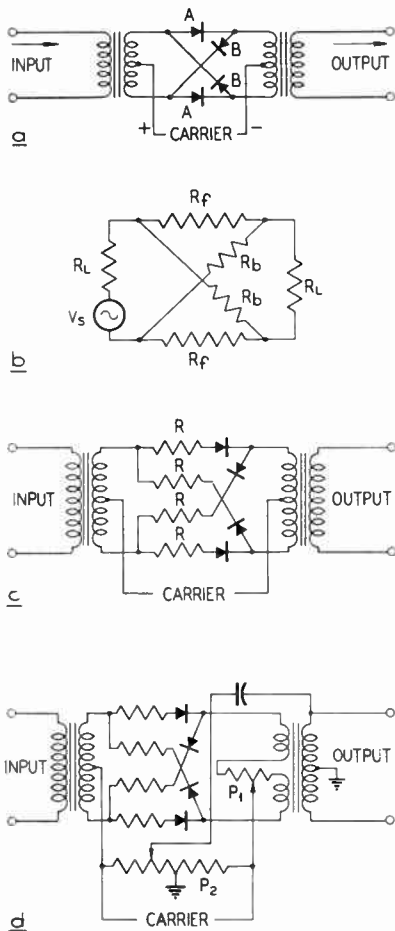

Figure 5. Modulator circuits

The signal voltage across a conducting rectifier is

$$E_s = V_s \frac{R_f}{2(R_1 + R_f)}$$

The carrier voltage across a conducting rectifier is

$$E_c = \frac{I_c}{2} R_f$$

where I_c is the total carrier current.

For a square wave carrier and idealized rectifier elements, overload will be reached when $E_s = E_c$.

$$\text{or } V_s (\text{max.}) = I_c (R_1 + R_f) \quad (1)$$

Similarly for a non-conducting element

$$E_s = \frac{V_s}{2} \text{ approx.}$$

$$E_c = \frac{I_c}{2} R_f \text{ as before}$$

Overload again occurs when $E_s = E_c$.

$$\text{or } V_s (\text{max.}) = I_c R_f \quad (2)$$

Obviously Equation 2 is smaller than Equation 1 and is the first to be exceeded as the signal input is increased. In a typical case where $R_1 = 600$ ohms and R_f about 50 ohms, the non-conducting rectifiers will overload with a signal less than one-tenth that required to overload the conducting branches.

This condition is easily remedied by increasing the carrier voltage across the non-conducting elements. Diagram (c) shows one of several possible methods for accomplishing this result, in this case by adding resistors R in series with each rectifier element. Although this method, in contrast to other possible methods, introduces some loss in the signal path, it is preferred because of its simplicity and excellent balancing properties.⁶

Germanium rectifier elements with either welded or pressure contacts replace the copper-oxide type used with previous carrier systems. They are more stable with respect to temperature and mechanical shock so that modulators employing these elements have excellent balance stability. This is an important consideration in

sending modulators where the desired sideband and the carrier frequency are in such close proximity as to prohibit adequate carrier suppression by the grouping filters alone. By adding the balancing potentiometers P_1 and P_2 as indicated in Diagram (d), the fundamental carrier output can be suppressed to any desired degree. In the receiving demodulators the desired sideband and the carrier are always widely separated so that a precise carrier balance is not necessary.

A power level of plus 10 dbm at the voice-band patching point is the standard level employed by the Telegraph Company for all carrier systems. To maintain this level throughout the modulator stages of a WN system would require electronic components of large power-carrying capacity. Therefore, the 7.2 kc sending modulators are designed for a single sideband loss of 30 db so that voice-band loads entering the system at plus 10 dbm are reduced to minus 20 dbm, this level being maintained throughout the sending terminal by single-tube, low-power amplifiers associated with each modulator stage and having sufficient gain to compensate for filter losses.

The receiving terminal operates at a somewhat higher level to insure an adequate margin for level adjustments when block patching between different systems. For this reason and also because distortion components in the demodulator amplifiers, particularly those involving harmonics and difference products of the signal frequencies, are so located as to produce crosstalk between bands, two-tube amplifiers of higher power capacity and lower distortion than the corresponding units in the sending terminal are employed. The final 7.2 kc receiving demodulator has sufficient gain and power output to restore the individual voice bands to the standard plus 10 dbm level.

To facilitate system adjustment and maintenance procedures a high-frequency 600-ohm decibel meter was developed. The meter is a rectifier type similar in principle to the current instrument used with lower frequency wire line carrier systems.⁷ Germanium crystal rectifier units and a shielded high frequency ad-

justable attenuator network are employed to obtain a flat frequency response. The response at 1000 kc is down only 0.3 db. Levels between minus 15 dbm and plus 35 dbm can be measured with an accuracy of 0.2 db in the 150 kc range.

Filters

The excellence of a carrier system depends to a large extent upon the quality of its filters. The design of the WN system filters, covered in a current paper,⁶ is predicated on a minimum signal-to-cross-talk ratio of 50 db for each voice band, a quite adequate margin for carrier telegraph service and sufficiently great to allow many such systems to operate in tandem. The end impedances are 600 ohms and sufficiently well balanced with respect to ground to mitigate the effects of longitudinal voltages which may be induced in external wiring. Both block and voice-band patching points are equalized where necessary to maintain a substantially flat frequency characteristic. The transmission-frequency characteristic of a typical voice band, showing the effect of the equalizing network, is given in Figure 6.

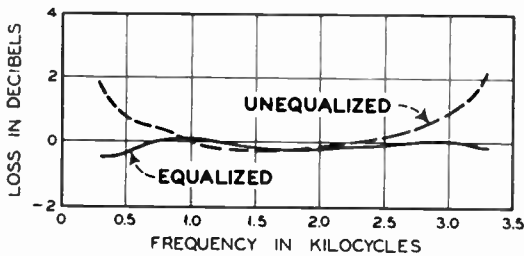

Figure 6. Voice band transmission frequency characteristic

Terminal Repeater

The function of the terminal repeater, Figure 7, is to bridge the gap between the channelizing equipment and radio relay terminal and to provide necessary monitoring and talking facilities. A pilot channel operating at 19.8 kc gives a continuous check of the circuit transmission equivalent and may also serve as a Morse or teleprinter talk circuit. A service phone chan-

nel occupies the unused portion of the spectrum below 3 kc. The line coupling panels match the 600-ohm terminal impedance to that of the particular circuit connecting to the radio terminal. Where the circuit is of appreciable length, receiving equalizers maintain a flat frequency characteristic.

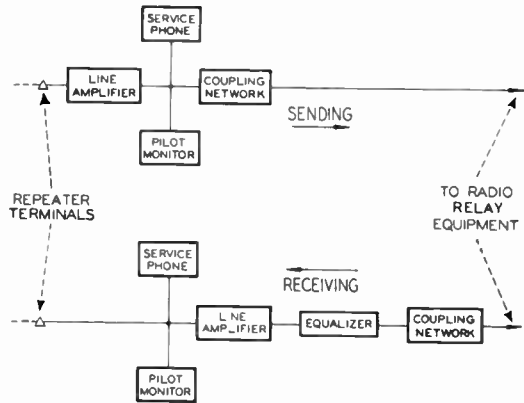

Figure 7. Terminal repeater

Carrier Supply Group

A measure of the frequency stability of a carrier system is the maximum amount by which voice frequencies, after passing through the system, differ from the frequencies originally transmitted. Frequency modulated telegraph channels will be subject to bias losses if this difference is excessive. The possibility of such losses is reduced to negligible proportions in the WN system by designing the carrier supply group for a frequency stability of better than .00066 percent.

It may be of interest to illustrate the relation between a given frequency error in the system base oscillator and the resultant error in the line frequency assignments of the various voice bands. In a carrier system employing tandem stages of modulation where the lower sideband in each stage is utilized, the line frequency error is

$$\Delta L = \Delta C (n_1 - n_2 + n_3 - n_4 \dots \text{etc.})$$

where ΔC is the base frequency error in cycles and $n_1, n_2, \text{etc.}$, are the harmonic relation of the carrier frequencies to the

system base frequency, listed in the order used.

For example, the line frequency error in Voice Band 8-C (see Table 2) for $\Delta C = 0.1$ cycle would be

$$\Delta L = 0.1 (2 - 6 + 11 - 21 + 42) = 2.8 \text{ cycles}$$

For a given base frequency error, the lower sideband method of tandem operation introduces no greater line frequency error than systems employing individual modulators for directly translating each voice band to its line frequency assignment.

A schematic layout of the carrier supply group is shown in Figure 8. Regular and spare supplies are identical and are energized by separate power distribution circuits for added reliability. A 3.6 kc temperature-controlled LC oscillator of good stability is employed to generate the system base frequency from which the carrier frequencies are derived in a conventional manner by means of a harmonic generator and appropriate harmonic selection filters.

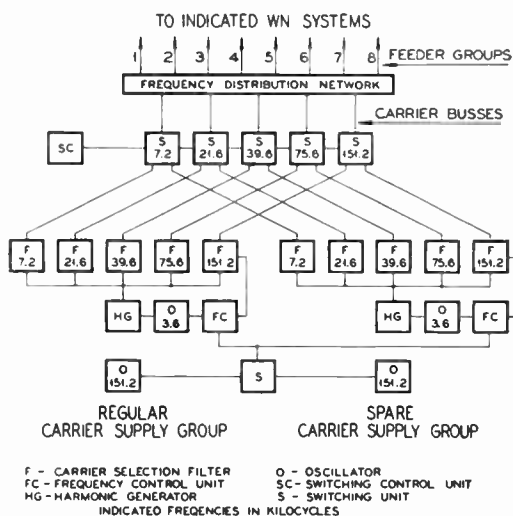

Figure 8. Carrier supply group

A temperature-controlled crystal oscillator operating at 151.2 kc is employed to continuously monitor the highest translating frequency, also 151.2 kc, derived from the harmonic generator. Monitoring is accomplished by a frequency-control

unit, essentially a phase detector, whose output voltage is proportional in magnitude and polarity to the phase difference between the two sources. By applying this voltage to a reactance tube frequency-control circuit incorporated in the base frequency oscillator, exact synchronism between the two sources is maintained. Thus the frequency stability of the entire terminal is identical to that of the crystal oscillator and well within the desired limits. Although this control arrangement may be somewhat unusual because of the high degree of frequency multiplication involved (42nd harmonic of 3.6 kc), yet properly designed damping characteristics render it completely stable in operation.

A meter in the frequency-control unit indicates the amount and polarity of the correction voltage being applied to the base oscillator. An associated alarm relay gives an audible and visual indication in the event the correction voltage should exceed 50 percent of its maximum allowable value, enabling the attendant to manually retune the base oscillator without interrupting the circuit. The crystal oscillator may be varied over a limited frequency range sufficient to compensate for differences in various crystal units and to permit frequency matching of all carrier supplies to a given standard.

A high degree of reliability is secured by providing duplicate sets of carrier generating equipment. Associated switching arrangements transfer the load from one to the other, either automatically or under manual control. The carrier switching panels contain two cathode-follower amplifiers each actuated by corresponding frequencies from the regular and spare carrier supply groups. A single output transformer is mechanically switched into the cathode of the appropriate amplifier, furnishing a very low impedance carrier source to energize the carrier bus. The buses are normally energized by the regular supply and their power levels are individually monitored by meter relays. A failure on any bus causes the corresponding meter relay to operate and transfer the entire office load to the spare supply where it will remain until manually restored. The level of each carrier fre-

quency from the idle supply is also monitored at all times to insure its readiness in case of need.

The carrier switching control panel provides visual means for indicating which supply group is carrying the office load and, in the event of a failure, indicates on which group it occurred. A master switch disables the automatic feature and permits manual control to be established for testing and maintenance purposes. In addition to a visual indication, an audible alarm is sounded upon the failure of any carrier frequency, regular or spare.

A frequency-distribution network inserts protective resistors between each carrier frequency bus and the multipled feeders for supplying the various WN systems in an office so that faults on any particular feeder group will not affect the levels of the other groups. Up to eight system terminals can operate from a single carrier supply group. The carrier frequencies are converted into the desired square wave form by appropriate amplifiers associated with the voice and block modulator groups. Each amplifier has sufficient power output to operate eight modulators.

Automatic and manual switching are also provided in connection with the regular and spare 151.2 kc crystal-controlled oscillators. Provisions are made for indicating the frequency difference between the two oscillators and for comparing them independently with a standard frequency source.

Performance

Signal-to-noise measurements on individual voice bands with all remaining bands carrying multichannel telegraph traffic averaged better than 50 db. This margin is quite adequate for tandem operation of as many systems as might reasonably be required to cover the continental United States and yet maintain a signal-to-noise ratio sufficiently great for telegraph and facsimile service. With the system operating over a radio relay circuit consisting of two terminals and seven repeaters, the comparable signal-to-noise ratio was approximately 43 db.

Observations of frequency stability over a period of several weeks indicated the maximum frequency shift in any voice band to be not greater than one-fourth cycle per second.

References

1. CARRIER TELEGRAPH SYSTEMS, F. B. BRAMHALL, *Electrical Engineering*, volume 63, August 1944, pages 283-6.
2. A MICROWAVE RELAY COMMUNICATION SYSTEM, G. G. GERLACH, *RCA Review*, volume VII, No. 4, December 1946, pages 576-600.
3. A PREVIEW OF THE WESTERN UNION SYSTEM OF RADIO BEAM TELEGRAPHY, J. Z. MILLAR, *Journal of the Franklin Institute*, volume 241, No. 12, June 1946, pages 397-413; and volume 242, No. 1, July 1946, pages 23-40.
4. AN FM TELEGRAPH TERMINAL WITHOUT RELAYS, F. H. CUSACK and A. E. MICHON, *AIEE Transactions*, volume 66, 1947.
5. COPPER-OXIDE MODULATORS IN CARRIER TELEPHONE SYSTEMS, R. S. CARUTHERS, *AIEE Transactions*, volume 58, June 1939, pages 253-60.
6. FREQUENCY TRANSLATION IN WIDE-BAND TRANSMISSION SYSTEMS, F. H. CUSACK, *Western Union Technical Review*, volume 2, No. 1, January 1948.
7. U. S. PATENT No. 2189660.
8. FILTERS FOR A 150-KILOCYCLE CARRIER SYSTEM, R. C. TAYLOR, *AIEE Transactions*, volume 67, 1948.



THE AUTHOR: J. E. BOUGHTWOOD has been associated with the Research Division of Western Union since his graduation from Northeastern University in 1930. After several years of experimental work in connection with d-c telegraph transmission, he became active in the development of carrier current systems. In this field he has been responsible for a number of innovations including the introduction of frequency modulation to the carrier telegraph art. He is currently in charge of an engineering group handling the electronic phases of carrier development for the Transmission Research Engineer. Mr. Boughtwood is a Member of the I.R.E. and A.I.E.E.

A Tunable Rejection Filter

R. C. TAYLOR

Reprinted from TRANSACTIONS of the A.I.E.E., volume 65, 1946, by permission of the American Institute of Electrical Engineers

In communication and allied branches of electrical engineering, it is frequently necessary to use a filter with a narrow stop band to reject a single interfering frequency. It is the purpose of this paper to describe the theory of operation and methods for design and reduction to practice of such a device which has proved to be valuable at frequencies from 1,000 to 20,000 cycles per second. The principles of the device are equally applicable at much lower¹ and at much higher frequencies.

The familiar bridge circuit of Figure 1, frequently employed as a delay circuit, is the basic arrangement for the narrow-band rejection filter. An elementary explanation of the device² sets forth that each of the bridge arms is resonant at the reject frequency and the inevitable dissipation is such that the four arms become equal resistances at the reject frequency, and the bridge is therefore balanced and the undesired frequency rejected. The impedance circle diagram of Figure 2 illustrates this concept. In the practical case, resistances are functions of frequency, and although the line and circle loci are distorted, the distortion is not

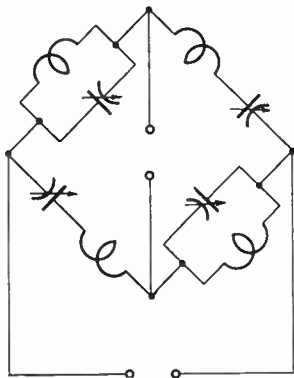

Figure 1. Basic circuit of the rejection filter

enough to destroy the usefulness of the concept, since most of the distortion is in those parts of the loci far from resonance. The circle applies to the parallel resonant arms and the vertical line to the series

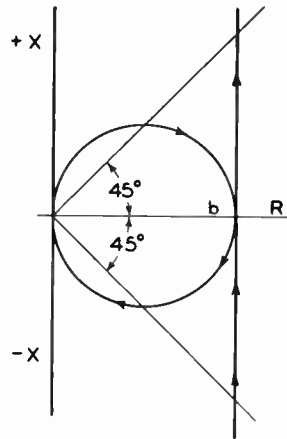

Figure 2. Impedance diagram, limiting case

resonant arms. The familiar half-energy points of the resonance curve are found at the intersections of the 45-degree lines with these loci, which Kennelly has called the quadrantal points.³ Both loci contain arrowheads to indicate the direction in which the tip of the impedance vector moves as the frequency increases. The narrowness of the stop region near the balance point b is a function of the velocity with which these vector loci are traced as the frequency is varied. Since they are traced most rapidly near resonance, which occurs at b , and particularly since they are traced in opposite directions near the balance point, a very narrow stop band is realized, the width of which is found to vary inversely as the circuit Q . A device of this kind rejecting 1,100 cycles per sec-

ond has been inserted in a telephone circuit with negligible loss of intelligibility.

The construction of such a device with the line exactly tangent to the circle and the resonance of all arms of the bridge occurring at the same frequency is difficult and unnecessary, since closely similar performance can be realized with the balance condition illustrated in Figure 3.

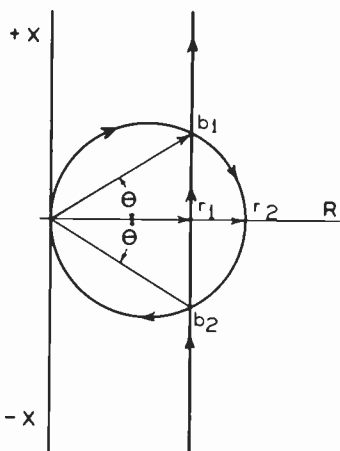

Figure 3. Impedance diagram, general case

In Figure 3, the balance point does not occur at resonance, and the series and parallel circuits have different resonant points shown at r_1 and r_2 . There are two possible balance conditions indicated by the intersection points b_1 and b_2 , and either can be obtained by adjusting the

resonant frequencies. The impedances of all four bridge arms at balance are equal both in magnitude and angle. This procedure requires much less accurate control of the resistance, which is often less predictable than the reactance, and assures a balance, since a balance is always possible if the line and the circle intersect. If the tangent condition is attempted, any increase in dissipation results in the separation of the two loci, and no balance is possible, although some attenuation can be obtained where the loci are nearest together.

Range of Adjustment

A considerable range of reject frequencies is obtainable with any given set of coils. Consider, for example, a coil that has no dissipation other than d-c resistance. The position of the straight line locus then is independent of frequency. The diameter of the circle locus is proportional to the square of the resonant frequency according to the equation,

$$\text{Resonant resistance} = \omega^2 L^2 / R_{dc}$$

If a rejection filter of this type, operating as shown in Figure 3, is tuned to successively lower frequencies, the circle locus will decrease in size until the tangent condition of Figure 2 is reached. With any further decrease in frequency, the loci will separate and no balance will be possible. If the frequency is increased

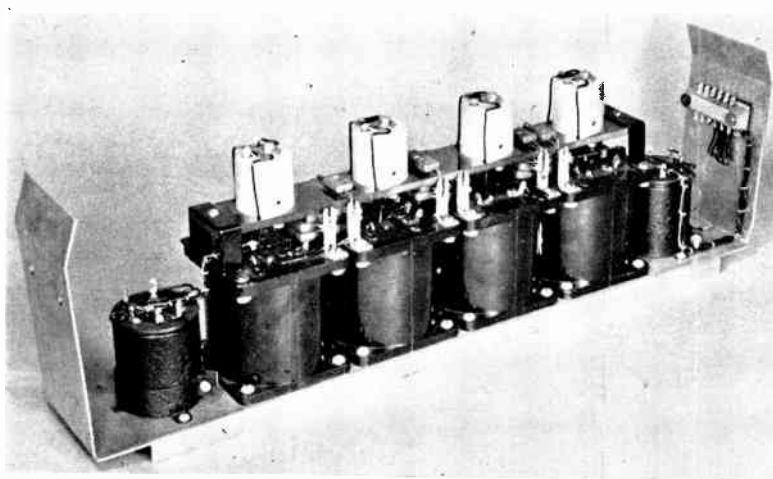

Figure 4. Tandem filter showing trimmer capacitors

above that corresponding to Figure 3, the diameter of the circle will increase as the square of the frequency, and the balance points b_1 and b_2 will become farther and farther separated from the resonance r_2 . Balance is still possible, since the loci intersect, but it is not usually desirable to use this condition, since it produces an effect very similar to reducing the Q . If an arbitrary standard were set up requiring the parallel resonant resistance to be not more than twice the series resonant resistance (line passing through center of circle), then the frequency range of adjustment in this case would be limited to $\sqrt{2}$ to 1. However, as bad a condition as this is seldom met in practice, and a range of adjustment approaching two to one is practicable in most cases. The range realized depends on the variation of dissipation with frequency and on the need for maximum narrowness of stop band.

Theoretically, infinite range of adjustment is obtained when the product of the series resonant and shunt resonant Q 's is constant. As an illustration, let the dissipation of the series resonant circuit be a series resistance independent of frequency and the dissipation of the parallel resonant circuit be a shunt resistance independent of frequency and, of course, slightly larger than the series resistance. This results in constant product of the Q 's and is also the condition for no distortion of the loci, and resonant resistance independent of frequency. Such a combination could be tuned to reject any frequency with equally good results. Practically, such a combination of properties is seldom available without loss of stability or circuit Q , and one is likely to find the resonant resistance of desirable components varying with the frequency, introducing some distortion of the loci and limiting the range of adjustment to about two to one.

Practical Circuit Arrangement

In practice it is usually preferable to modify the circuit of Figure 1 to that of Figure 5, where inductances with the same letter designations are on the same core. Imperfect coupling between windings is not often serious, the principal

effect being the inclusion of a series inductance in the parallel resonant branches. Since at frequencies much greater than balance frequency, the useful frequencies flow to the receiver through the parallel resonant arms of the bridge, the series inductance will limit the high frequency response. In practice this limitation is not severe, since the parallel resonant inductance is a small one if the Q is ten or greater; leakage inductance can easily be

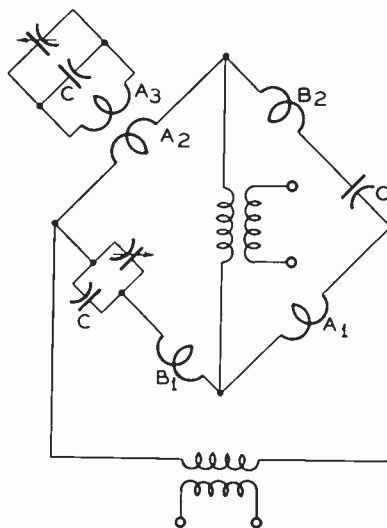

Figure 5. Practical circuit of the rejection filter

made a small fraction of the total; and consequently a wide pass band above the reject frequency will exist. It has been found convenient to select transformation ratios that make the three capacitors marked C of equal capacity.

Since the stop band is very narrow, it is usually desirable to use trimmer capacitors which permit about one per cent adjustment of capacity (Figures 4 and 5). Larger air capacitors with precision mechanical drives are convenient for greater range. Figure 5 shows input and output coupling transformers to match impedance levels.

Attenuation Formulas and Graphs

The attenuation of all such reject filters is shown as a function of frequency in Figures 6 and 7. These curves can be

represented for attenuations greater than ten decibels by the following equation derived in the appendix:

$$\alpha = 20 \log_{10} (K/W) \quad (1)$$

These curves are universal curves, since the constant K has the same dimen-

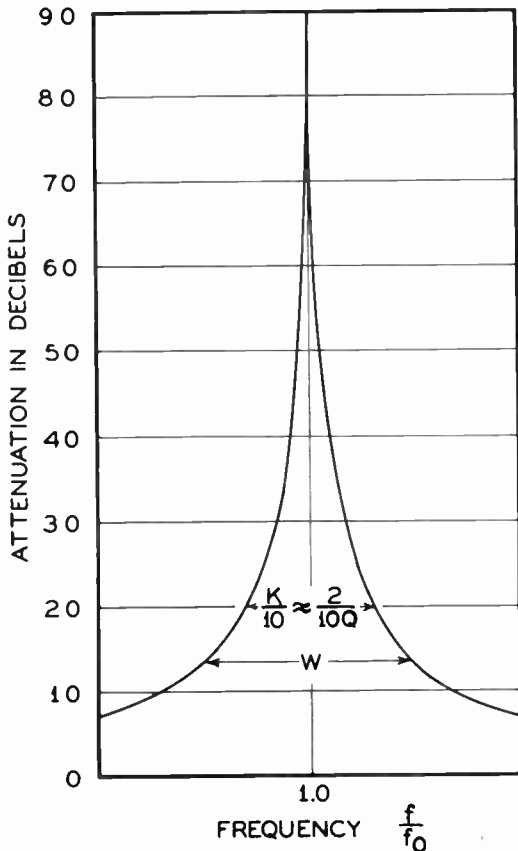

Figure 6. Attenuation of single rejection filter

sions as the variable W , the width of the stop band on the frequency scale at attenuation α . In other words, the frequency scale may be thought of as plotted in K units as indicated in Figure 7.

In Figure 7 the dotted curve at A indicates either an imperfect balance or noise present in the test equipment, and the dotted extension at B indicates a graphical method of determining K . If the data are plotted with width in cycles per second as abscissa instead of K units as abscissa,

the intersection of the straight line with the axis gives the actual value of K in cycles per second.

A slightly more complicated empirical equation useful down to three decibels is

$$\alpha = 20 \log_{10} [K/W + 1/(1+K/W)] \quad (2)$$

K can be determined graphically from the curves, as indicated, or computed by formula 25. As shown in the appendix, a better approximation for attenuations between one-tenth decibel and three decibels is given by

$$\alpha = 20 \log_{10} [1 + (1/2)(K/W)^2] \quad (3)$$

The attenuation curve is rather difficult to measure at large attenuations, since either or both low frequency noise and harmonics of the reject frequency tend to reduce the apparent attenuation. Another difficulty is the requirement of very small frequency steps near the reject frequency. A cycles increment dial on a beat frequency oscillator is a convenience for these tests.

Figure 7 suggests the use of two crossed rejection filters as a discriminator in frequency modulation receivers, provided some ten decibels of minimum loss can be tolerated.

Two Reject Filters in Tandem

If a rejection band wider than that provided by one section of this type of filter is required to secure sufficient band width to reject a narrow band of frequencies rather than a single frequency, it may be desirable to widen the stop band by using

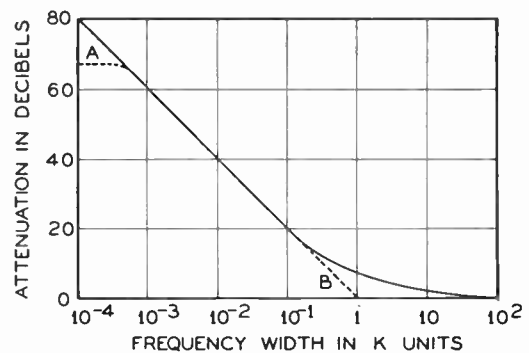

Figure 7. Graphical method of determining K

two or more filters in tandem, each filter rejecting a slightly different frequency. In some cases this arrangement may be found advantageous to preserve the required attenuation if the circuit elements are not sufficiently stable. Two sections result in a characteristic of the type shown in Figure 8. Using equation 1, it can be shown (see appendix) that

$$W_0/W_s = \sqrt{2 \text{antilog}_{10} (\alpha_0/20)} \quad (4)$$

where W_s is the width of one filter at the attenuation α_0 . The increase in width is shown by Table I, which shows a very large relative increase at high attenuations.

Stability Measurements

In the construction of these filters, it is essential that all components, including the resistances of the circuit, have good stability with respect to temperature, humidity, and voltage. Silvered-mica ca-

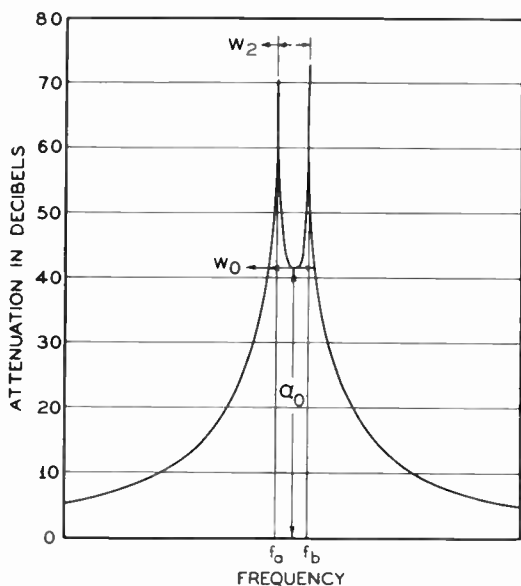

Figure 8. Attenuation characteristic of tandem rejection filters

pacitors with air trimmers and powdered-iron cores made of Carbonyl E iron have been found to be of satisfactory stability. The final stability coefficient of the rejection frequency and attenuation is a com-

plex function of the separate coefficients of the filter components and also of whichever of the two possible balance points is selected. One model designed to be tunable from 3,000 to 4,800 cycles per second

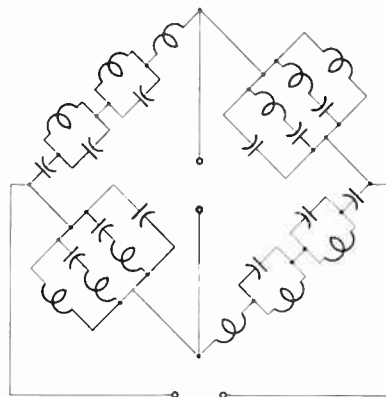

Figure 9. Multiple frequency rejection filter

was adjusted to 70 decibels attenuation at 3,600 cycles per second, and subjected to temperatures from 55 to 100 degrees Fahrenheit. The peak attenuation decreased about five decibels and the frequency at which the peak occurred changed less than two cycles per second. In any individual case, the various temperature coefficients can be made to counteract each other if components of both positive and negative coefficients are available.

Relation to Filter Theory

While it is obviously appropriate to call this device a filter, since it has pass and stop frequency regions, the attenuation in the stop band is explained only by the resistances present, while conventional filter theory excludes resistance and deals with reactances. The device illustrated in Figure 1 is an all-pass network with no attenuation at any frequency when considered as a conventional filter. It is only when resistance is considered as in Figures 2 and 3 that the attenuation region appears. If the resonant frequencies of the series tuned and shunt tuned arms are slightly separated, then an attenuation band is predicted by filter theory; but only small attenuations will be realized

when reactances of the size given by the design equations are used.

The extension of these principles to multiple reject frequencies in a single section is illustrated in Figure 9. Such a device results in an economy of elements but requires variable inductors as well as capacitors, and the adjustments of various reject frequencies are not independent, so that a more practical solution may be the use of simpler sections in tandem. The bridge arms in Figure 9 are shown in a canonic form.⁴

Coil Design

Since the Q of the circuit determines the narrowness of the rejection band and the capacitors are responsible for little

Table I. K Units

Db	W_x	W_o	W_o/W_x
20	0.1	0.447	4.47
34	0.02	0.20	10.
40	0.01	0.141	14.1
60	0.0031	0.0447	44.7
74	0.0002	0.02	100.

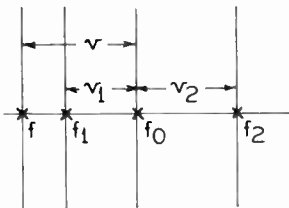
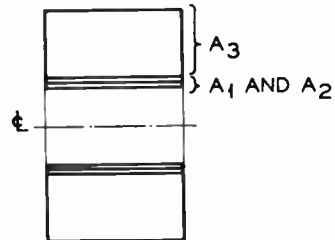

Figure 10. Relation of resonant and balance frequencies

of the loss in the circuit, the design of coils with a specified high Q is fundamental. Another important factor results from the large ratio between the inductances of the parallel and series tuned branches. Equation 32 shows this ratio to be approximately Q^2 and therefore may be as high as 100,000 or more. This indirectly determines the impedance level of the bridge, since the series-tuned inductances should not be so large as to lose Q from distributed capacity and leak-age effects, and the parallel-tuned in-

ductance should not be so small as to require too small a number of turns, since it is impossible to get close coupling to the tuned winding with less than one turn, and the change of one turn in a small number results in a limited choice of inductance.



A-PARALLEL RESONANT WINDING

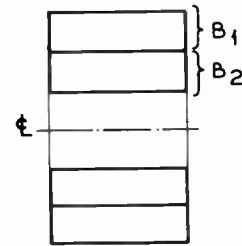

B-SERIES RESONANT WINDING

Figure 11

Typical windings are illustrated in Figure 11. Notice that in Figure 11A most of the space is allotted to the tuned winding to get maximum Q and consequently minimum width of the reject band.

Application of Rejection Filters

These paragraphs submitted by Author, subsequent to presentation of paper.

Rejection filters in the telegraph plant are of such widely different forms that one would never suspect that the various models belong to the same family. One of the original applications, dating from 1934, was a single-section type designed to remove 25-cycle power induction and pass 23-cycle teleprinter signals on grounded duplex circuits. To secure such sharp discrimination requires high Q , and high Q at low frequencies means big coils. Each of the two coils weighed more than one hundred pounds. A contrasting application uses four coils each weighing about

one pound to remove long-wave radio telegraph interference from a railroad's type C carrier. After demodulation, the radio appeared at 1100 cycles, right in the middle of a voice band. A tandem type rejection filter tuned to 1100 cps removed the interference, yet so little of the voice signal was cut out that listeners were unaware of any change except that the interference was gone.

By far the most important application has been on type F and G carrier circuits to provide reliable operation of pilot tones, used for monitoring and automatic level control purposes. The filters insure that no stray carrier can pose as a pilot frequency and give false information about system conditions. They prevent pilot tones from entering the terminal, where they could beat with bona fide demodulating carriers or be patched through to regulate the gain of one system by the fluctuations of another. A set of five tandem-type rejection filters, each tunable at the factory over a range of frequencies of 1.6 to 1, has been designed for this purpose so that any frequency from 3.0 to more than 30 kilocycles can be removed with minimum disturbance to the rest of the spectrum. They all look like the one in Figure 4.

APPENDIX

Attenuation Formulas

The propagation constant of a bridge or lattice network is given by⁴

$$\alpha = 20 \log_{10} [(\sqrt{ZY} + 1) / (\sqrt{ZY} - 1)] \quad (5)$$

and balance of the bridge is obtained when $ZY = 1 + j0$. Two approximate forms of the equation for the propagation constant are of interest in this application. The first is applicable when

$$ZY = 1 + jT \quad T \ll 1$$

and results in

$$\alpha = 20 \log_{10} (4/T) \quad (6)$$

The other is applicable when

$$ZY = -S + jT \quad T \ll S$$

and results in

$$\alpha = 20 \log_{10} (1 + T/S^{3/2}) \approx 17.37T/S^{3/2} \quad (7)$$

The impedance of the series resonant arm is given by

$$Z_1 = -jX_1[(f_1/f) - (f/f_1) + jR/X_1] \quad (8)$$

where

$$X_1 = 2\pi f_1 L_1$$

and the admittance of the parallel resonant arm is given by

$$Y_2 = -jB_2[(f_2/f) - (f/f_2) + jG/B_2] \quad (9)$$

where

$$B_2 = 2\pi f_2 C_2$$

and R , X , G , B , Z , and Y have their usual Ohm's law meaning, and f_1 and f_2 are the resonant frequencies of Z_1 and Y_2 respectively. The appearance of the expressions may be simplified by writing them as

$$Z_1 = -jX_1(m_1 + j1/Q_1) \quad (8a)$$

$$Y_2 = -jB_2(m_2 + j1/Q_2) \quad (9a)$$

Using equations 8a and 9a,

$$Z_1 Y_2 = -X_1 B_2 [m_1 m_2 - 1/Q_1 Q_2 + j(m_1/Q_2 + m_2/Q_1)] \quad (10)$$

where

$$X_1 B_2 = 4\pi^2 f_1 f_2 L_1 C_2 = f_1 L_1 / f_2 L_2 \quad (11)$$

at balance

$$\sqrt{ZY} = 1 + j0 \quad (12)$$

Consequently balance conditions are

$$m_1/Q_2 + m_2/Q_1 = 0 \quad (13)$$

and

$$1/X_1 B_2 = 1/(Q_1 Q_2) - (m_1 m_2) = 1/Q_a^2 \quad (14)$$

Calculation of m_1 and m_2 near balance may be made easier if f/f_1 is written (see Figure 10) as

$$f/f_1 = 1 - (v - v_1)/f_1 = 1 - a \quad (15)$$

and similarly

$$f/f_2 = 1 - (v - v_2)/f_2 = 1 - b \quad (16)$$

Then

$$m_1 = 1/(1-a) - (1-a) = \frac{1}{2a+a^2+a^3+\dots} \quad (17)$$

$$m_2 = 1/(1-b) - (1-b) = \frac{1}{2b+b^2+b^3+\dots} \quad (18)$$

and

$$m_1 m_2 = 4ab + 2a^2b + 2ab^2 + 2a^3b + \frac{a^2b^2 + 2ab^3 + \dots}{\dots} \quad (19)$$

Near balance,

$$m_1 m_2 - 1/Q_1 Q_2 \approx -1/Q_a^2 \quad (20)$$

Since Q_1 and Q_2 vary slowly and $m_1 m_2 \ll 1/Q_1 Q_2$

$$Z_1 Y_2 \approx 1 - jQ_a^2 (m_1/Q_2 + m_2/Q_1) \quad (21)$$

Equation 6 is applicable, giving

$$\alpha = 20 \log_{10} [4/Q_a^2 (m_1/Q_2 + m_2/Q_1)] \quad (22)$$

Farther from balance, $m_1 m_2 \gg 1/Q_1 Q_2$ and

$$Z_1 Y_2 \approx -Q_a^2 m_1 m_2 - jQ_a^2 (m_1/Q_2 + m_2/Q_1) \quad (23)$$

Equation 7 is applicable, giving

$$\alpha = 20 \log_{10} \left[1 + \frac{Q_a^2 (m_1/Q_2 + m_2/Q_1)}{(Q_a^2 m_1 m_2)^{3/2}} \right] \quad (24)$$

The simplified formulas 1 and 3 can be obtained from 22 and 24 by letting $Q_1 = Q_2$, which allows v_1 to be taken equal to v_2 . Letting the definition of K be

$$K = 2f_0 Q/Q_a^2 \quad (25)$$

Equation 22 becomes

$$\alpha = 20 \log_{10} (2f_0 Q/WQ_a^2) = 20 \log_{10} (K/W) \quad (22a)$$

and equation 24 becomes

$$\alpha = 20 \log_{10} [1 + (1/2) (Q_a/Q)^3 (K/W)^2] \quad (24a)$$

which is identical with equation 3 when $Q_a = Q$.

Stop Band for Two Filters in Tandem

If a filter rejecting frequency f_a is connected in tandem with a similar one rejecting f_b where $f_b - f_a = W_2$ (Figure 8), the sum of the attenuations will have a minimum α_0 midway between f_a and f_b . If the component attenuations are large enough for formula 1 to apply, we can determine the width W_0 of the reject band having attenuation α_0 by the following process. Let the width at frequency f (less than f_a) of the filter rejecting f_a be called W . Then the filter rejecting f_b has width $W + 2W_2$ at frequency f .

At the central minimum

$$\alpha_0 = 20 \log_{10} (K/W_2)^2 \quad (26)$$

Let $f = f_1$ and $W = W_1$ at the edge of the stop band having attenuation α_0 . Then

$$\alpha_0 = 20 \log_{10} (K/W_1) [K/(W_1 + 2W_2)] \quad (27)$$

For a single section with attenuation α_0 ,

$$\alpha_0 = 20 \log_{10} (K/W_s) \quad (28)$$

Consequently, from equations 26, 27, and 28,

$$W_1 (W_1 + 2W_2) = W_2^2 = KW_s \quad (29)$$

and since

$$W_1 = W_0 - W_2 \quad (30)$$

equation 29 can be rewritten to give

$$W_0/W_s = \sqrt{2K/W_s} = \sqrt{2 \text{ antilog}_{10} (\alpha_0/20)} \quad (31)$$

and

$$W_0/W_2 = \sqrt{2} \quad (31a)$$

Design Equations

Combining equations 11 and 14,

$$L_1/L_2 = f_2 Q_a^2 / f_1 \quad (32)$$

The second equation to permit solving for L_1 and L_2 is obtained by setting the quotient of equations 8 and 9 equal to R_0^2 , where R_0 is the resistance of generator and load. This results at pass band frequencies in

$$L_1 L_2 = R_0^2 / 4\pi^2 f_1 f_2 \quad (33)$$

Combining equations 32 and 33, we get

$$L_1 = Q_a R_0 / 2\pi f_1 \quad (34)$$

and

$$L_2 = R_0 / 2\pi f_2 Q_a \quad (35)$$

L_1 and L_2 are the inductances actually effective in the bridge arms. If the coupled arrangement of Figure 5 is used, the coupling coefficients increase the inductances as follows:

$$L_1 = (Q_a R_0 / 2\pi f_1) 2 / (1 + k_1) \quad (34a)$$

and

$$L_2 = R_0 / 2\pi f_2 Q_a k_2^2 \quad (35a)$$

where k_1 is the coupling coefficient between windings B in Figure 5 and k_2 is the coupling coefficient between the tuned winding A and either of the A windings included in the bridge arms.

References

- CONTROL OF INDUCTIVE INTERFERENCE TO TELEGRAPH SYSTEMS, J. W. MILNOR, AIEE TRANSACTIONS, volume 59, 1940, August section, pages 469-74.
- UNITED STATES PATENT 2,173,722.
- ELECTRICAL VIBRATION INSTRUMENTS (book), A. E. KENNELLY, Macmillan Company, New York, N. Y., 1923.
- ELECTRICAL NETWORKS, volume II, E. A. GUILLEMIN, John Wiley and Sons, Inc., New York, N. Y., 1935.



THE AUTHOR: R. C. TAYLOR is a graduate of Case Institute of Technology, class of '23. He has been concerned largely with coil and filter design in his association with Western Union and the results of his work are found throughout the carrier, cable and land line plant in amplifiers, modulators, filters, test equipment and many other devices. The system of modulation on which the WN-2 carrier is built is his invention, and he is also responsible for the shell-type powdered iron core so widely used in carrier equipment. He is an associate of the A.I.E.E.



TELEFAX TRANSCEIVER

A new model, developed especially for interchange of telegrams by facsimile, between patrons and Western Union main offices.

The Development of Western Union Switching Systems

R. F. BLANCHARD and W. B. BLANTON

(Continued from TECHNICAL REVIEW, January, 1948)

In the preceding article, the fundamentals of the plug and jack type of reperforator switching unit were discussed and the principal items of equipment enumerated (See Figure 10.) This article will elaborate on the outline already given and describe additional equipment and apparatus necessary for the proper functioning of a switching system. In addition to the items already discussed, it includes Receiving and Sending Concentrators; Way-station Circuits; Supervisory, File, Testing and Regulating Positions; Spill-over Positions; and a variety of Supervisory Signals and other special units.

Intra-office Switching Facilities

Intra-office switching circuits between the jack turrets and line sending positions differ, depending upon whether they serve a destination having a single sending channel or several channels. Where a sending destination has two or more channels, the intra-office switching circuit is on a multi-path basis, and so arranged that when an intra-office transmitter is plugged up to one of these paths, it may obtain a connection to any one of the channel sending positions for that destination.

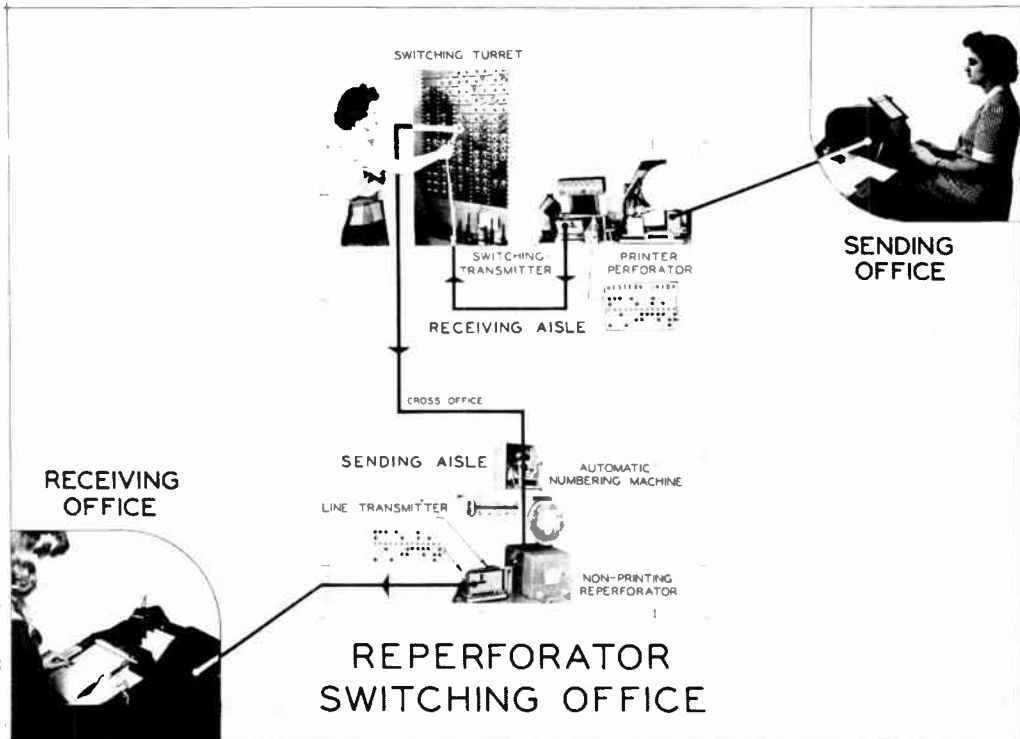

Figure 10. General plan of reperforator switching

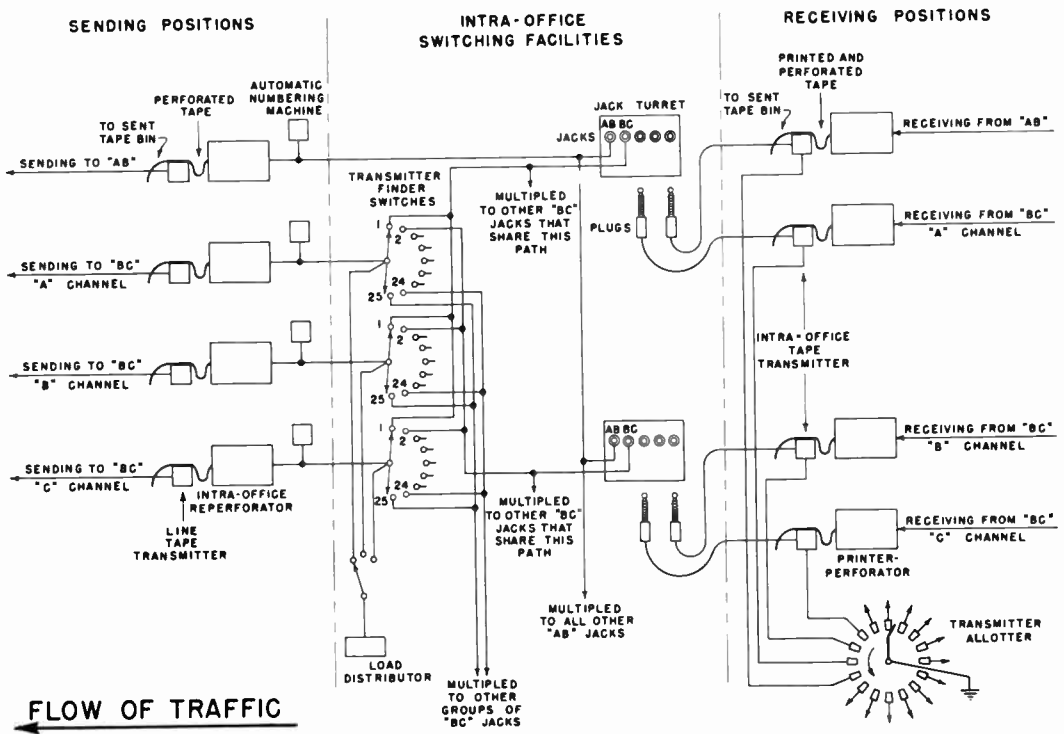

Figure 11. Switching to single-channel and multi-channel circuits

Figure 11 is a theoretical block diagram which shows two types of intra-office switching circuits, one for a single-channel circuit designated as AB, and the other for a three-channel circuit designated as BC. The flow of traffic in this diagram, as in all diagrams used in these articles, is from right to left.

The intra-office reperforator shown on the sending channel of circuit AB terminates an intra-office circuit that is connected to all of the AB jacks in the various turrets. Thus, there is only one intra-office path over which AB can be reached. If two or more transmitters are plugged up to such an intra-office circuit, the transmitter allotter, to be described later, will function to permit only one transmitter at a time to be electrically connected.

The sending channels of multi-channel circuits, however, require some method of load distribution to their associated intra-office reperforators. If individual intra-office paths were provided for each channel, inefficient load distribution would re-

sult due to the fact that a switching clerk would be compelled to choose the particular channel of a circuit to which she would switch each telegram. It is faster, better and cheaper to distribute the load by automatic methods.

There are several intra-office paths, in some instances as many as 25, over which a multi-channel destination may be reached. Each path, shared by jacks in two or more turrets, is connected to a group of "transmitter-finder" switches associated with the intra-office reperforators on the sending positions for that destination. These transmitter-finder switches function to connect any one of the reperforators to any one of the intra-office paths serving that circuit. Therefore, in the case of a three-channel circuit such as BC, three intra-office transmitters, each having access to a different intra-office path, may send simultaneously into the three reperforators.

A "load distributor", common to all channels of a multi-channel circuit, functions to determine which channel shall re-

ceive the next intra-office connection. For example, in the case of circuit BC in Figure 11, the load distributor would direct the first message to channel "A", the second to channel "B", the third to channel "C", the fourth to "A", and so on, except that when a channel is found "busy", the load distributor will by-pass that channel and direct the message to the next idle channel.

Intra-office Circuit Operation

Nine conductors are used in establishing an intra-office connection, thereby requiring that plugs and jacks be of the nine-conductor type. Figure 12 shows a nine-conductor plug and jack which were developed for use in reperforator switching. Three of the conductors perform functions required in establishing and, at the end of a message, disconnecting the intra-office connection, while the other six conductors are involved in the transmission of characters into the intra-office reperforator from an intra-office transmitter.



Figure 12. Nine conductor plug and jack

Impulse Unit

Transmission from automatic numbering machines and intra-office transmitters into intra-office reperforators is at the rate of 150 words per minute. (In earlier offices, a speed of 125 words per minute is used but plans are under way to convert them to 150 words per minute.)

Intra-office transmission at 150 words per minute, which is approximately two

and one-third times the speed of reception on line receiving printer-perforators, enables the switching clerk to offset the time consumed in performing the switching operation, and the time that may elapse while the transmitter is waiting for a connection.

Figure 13 shows the six conductors used in intra-office transmission, five for the transmission of the 5-unit code signals, and one for stepping the numbering machine or intra-office transmitter to the next character. The 5-unit code pulses for a character are transmitted simultaneously. The use of six conductors makes possible the simultaneous transmission of the code pulses, which enables the intra-office apparatus to operate reliably at 150 words per minute with very little maintenance attention.

The impulse unit shown on the left of Figure 13 furnishes the five selection, the step, and the punch pulses for transmitting characters into the reperforator. It consists of a constantly rotating shaft equipped with eight cams and cooperating contacts (only seven are shown, the eighth being used in a flashing lamp circuit). Each cam has two lobes. In each revolution, the cooperating contacts are closed twice, the time and length of closure being determined by the position and length of the lobes. One character is transmitted per half revolution, therefore for 15 characters per second (150 words per minute) the impulse unit is operated at seven and one-half revolutions per second. The timing chart of the closure time for the contacts during the transmission of one character in one-fifteenth of a second ($0.066\frac{2}{3}$ seconds) is shown in Figure 14.

A unit assembly of eight sets of contacts as shown in Figure 15 is termed an "impulse unit". An economical arrangement for actuating the contacts of four impulse units is provided by an impulse unit sub-base illustrated in Figure 16. The sub-base has one motor which drives a shaft equipped with two sets of eight cams. Four impulse units, each on a plug-in basis, are mounted on one sub-base, two on either side of the cam shaft. Thus two impulse units are actuated by the same set of eight cams.

Figure 13. Intra-office transmission

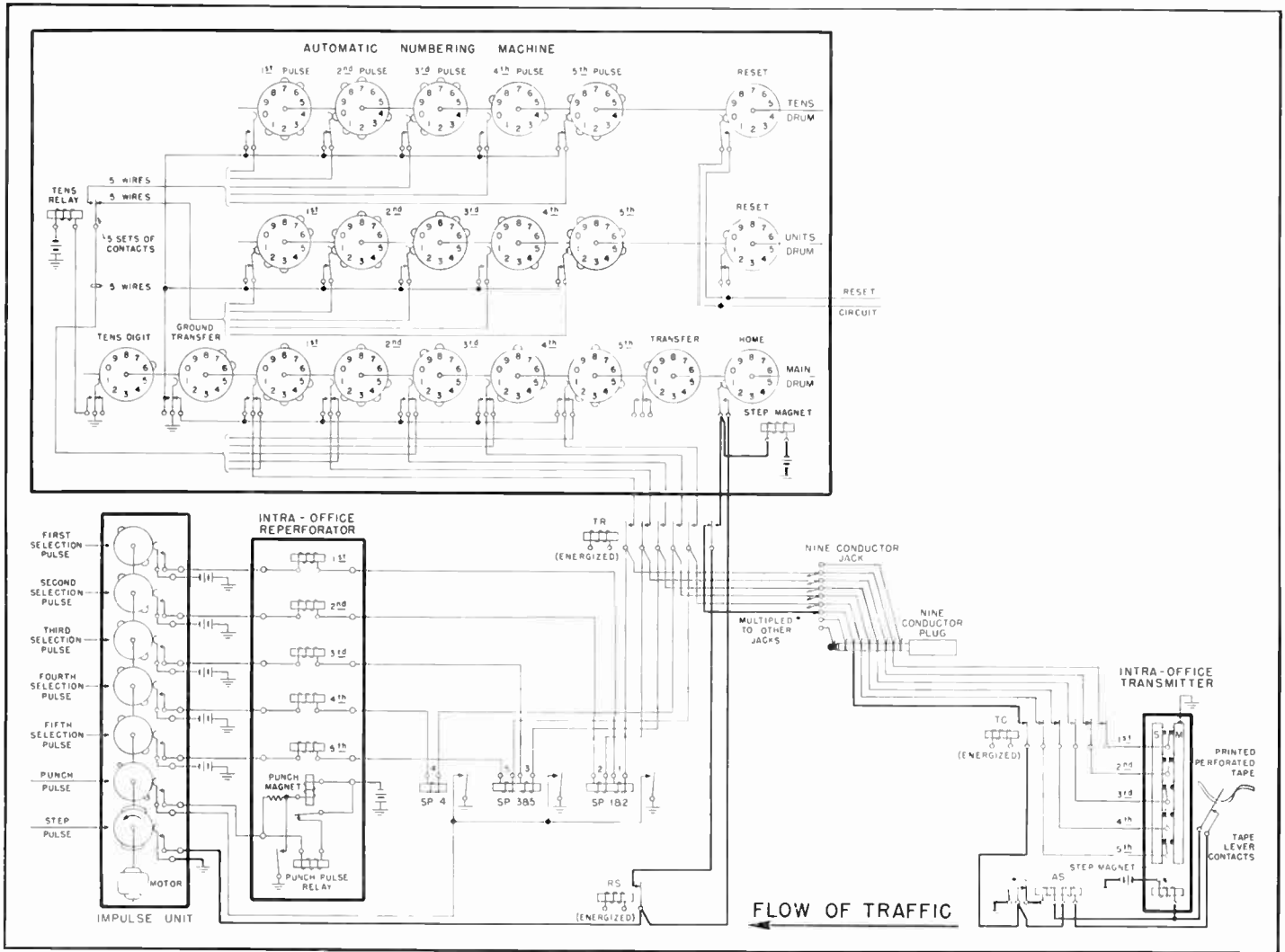

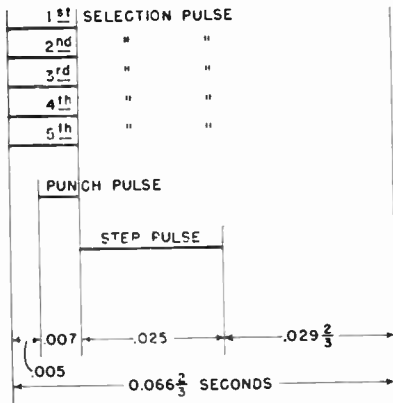

Figure 14. Timing chart for one cycle ($\frac{1}{2}$ revolution) of impulse unit

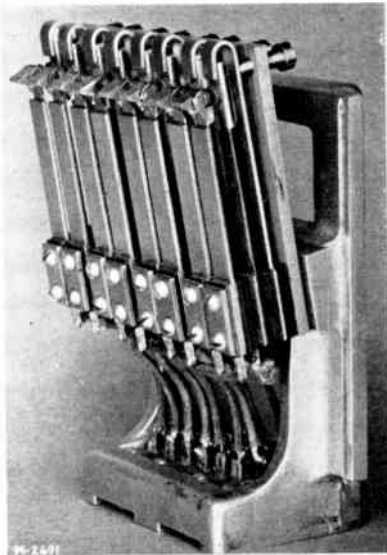

Figure 15. Impulse unit

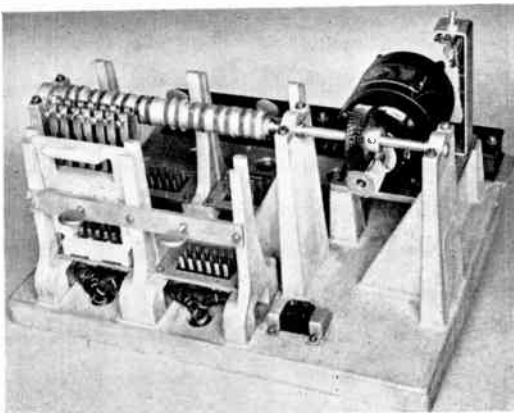

Figure 16. Impulse unit sub-base

When the intra-office transmitter is sending into the reperforator, Relays TC, TR, and RS are in the energized (operated) condition as shown in Figure 13. The five selection pulse conductors extend from battery, through the impulse unit contacts, reperforator magnets, windings of selection impulse relays SP 1&2, SP 3&5, and SP 4, to the tongues of the transmitter. The step pulse conductor, shown in heavy lines in order to distinguish it more readily, extends from ground through the impulse contacts, the windings of auto-stop relay AS, and transmitter step magnet to battery.

Transmission of the code characters from the printed-perforated tape at the line circuit receiving position to the intra-office reperforator is accomplished in the following manner. Assume that a code character has just been transmitted and the impulse unit is in the part of its cycle (see Figure 13) where it is closing the step pulse contacts. The step pulse energizes the step magnet of the transmitter. The operation of the step magnet armature pulls the feeler pins down and causes their cooperating tongues to move to the spacing bus bar (S) and the tape to advance to the next character. At the end of the step pulse, the step magnet de-energizes and releases the feeler pins. Each feeler pin that encounters a hole in the tape will project through the hole and its cooperating tongue will move to the marking bus bar (M). Each feeler pin that encounters a position in the tape which is not perforated will be restrained by the tape and its cooperating tongue will remain on the spacing bus bar.

At the closure of the five selection pulse contacts on the impulse unit, a current flow will result over those selection pulse conductors which are grounded at the transmitter, thus producing "marking" signals. No current will flow over those selection pulse conductors that are connected to transmitter tongues which are on the spacing bus bar, thus producing "spacing" signals. The transmitter in Figure 13 is shown set up for code character "A", tongues 1 and 2 being "marking" and tongues 3, 4, and 5 being "spacing".

A marking signal over a selection pulse

conductor will operate the selection pulse relay (SP) and the reperforator selection magnet associated with that conductor. The code character "A" will cause relay SP 1&2 and reperforator magnets 1 and 2 to operate.

During the latter half of the five selection pulses, the impulse unit closes the punch pulse contacts. It will be noted that the front contacts of selection pulse relays (SP) are included in the punch pulse circuit, and that it is necessary that at least one of the relays SP be energized for the reperforator to receive a punch pulse. When any code character except a "blank" (all five units spacing) is received in the reperforator, one or more of the selection pulse relays (SP) will be operated and the impulse unit will send a punch pulse into the reperforator. This energizes the punch pulse relay which electrically locks up in the operated condition and causes the punch magnet to operate, thus punching the received character code and a feed hole in the tape. When the punch magnet de-energizes, the tape is advanced to the next position and the reperforator is reset in preparation to receive the next character. While the reperforator is perforating a received character code, the step pulse to the transmitter causes it to go through the cycle of advancing its tape to the next character and setting up its tongues to correspond to the code combination of that character.

Automatic Numbering Machine

When the operator plugs into an AB or BC jack (see Figure 11) and a connection is obtained to a perforator, an automatic numbering machine functions. The automatic numbering machine is a form of transmitter that sends a series of predetermined characters. It functions in a way somewhat similar to a tape transmitter. Whereas the tape transmitter determines the code combination that will be transmitted by feeler pins "feeling" for the holes in perforated tape, the automatic numbering machine has the code combinations for its predetermined characters set up by means of studs which screw into threaded holes in rotating drums. The studs actuate contacts con-

nected to the selection pulse conductors; the presence of a stud actuates its cooperating contact to apply a ground for a marking signal, the absence of a stud removes the ground for a spacing signal.

A two-digit numbering machine has a main drum, a "tens" drum, and a "units" drum. A three-digit numbering machine, the latest type and illustrated in Figure 17, has the same three drums plus a

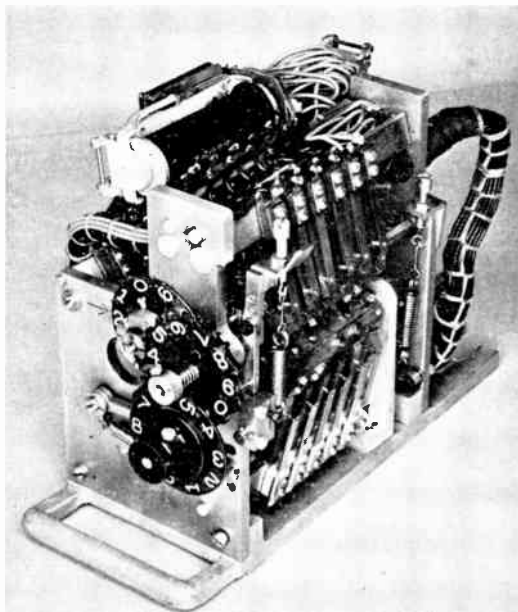

Figure 17. Automatic numbering machine

"hundreds" drum. Each drum can be set up for ten characters. The main drum, which makes one complete revolution (i.e., ten steps) each time the numbering machine operates to send a sequence number series, is set up with the characters that are always the same in each series. The tens drum is advanced one step when the units drum steps from 9 to 0. Similarly, the hundreds drum is advanced one step when the tens drum steps from 9 to 0.

A two-digit numbering machine is included in the schematic diagram of Figure 13. The arrangement of the characters on the ten positions of the main drum for

a typical office, for example, Atlanta, would be as follows:

- Position = 1—Blank
- " = 2—Letter Shift
- " = 3—Q (Call letter for Atlanta)
- " = 4—A (designating the first channel to the sending destination: "B" would be used for the second channel, "C" for the third, etc.)
- " = 5—Figure Shift
- " = 6—Transfer to tens drum for tens digit
- " = 7—Transfer to units drum for units digit
- " = 8—Letter Shift
- " = 9—Space
- " = 10—Blank

Transmission from the automatic numbering machine is accomplished by the selection, punch and step pulses in the same manner as previously described for the intra-office transmitter. After transmission of a code character, the following step pulse causes the step magnet to advance the main drum one step in preparation for transmitting the next character.

When the main drum reaches its sixth position, the five selection pulse conductors are extended to the tens drum contacts in order that the tens digit will be transmitted. This is accomplished by the closure of the "Tens Digit" contacts (located on extreme left of the main drum) which causes the "Tens Relay" to operate. At the same time, the operation of the "Ground Transfer" contacts (located second from left-hand end of the main drum), disconnects ground from the marking bus wire of the main drum and connects the ground to the marking bus wire of the tens and units drums.

Similarly, when the main drum is at its seventh position, the units digit will be transmitted as the five selection pulse conductors are extended to the contacts of the units drum by the de-energization of the "Tens Relay". The "Ground Transfer" contacts of the main drum still maintain a ground on the marking bus wire of the units drum. When the main drum advances to its eighth position, the "Ground Transfer" contacts remove the ground from the units and tens marking bus wire and reconnect it to the main drum marking bus wire, thus causing the transmission into the reperforator to

again take place from the contacts of the main drum.

The main drum of the numbering machine is actuated by the step magnet. The stepping of the units and tens drums is accomplished by a Geneva wheel and cam between the main and units drums, and by a Geneva wheel and cam between the units and tens drums. The hundreds drum is operated from the tens drum by a cam-operated pawl and ratchet.

Transmitter Allotter

When a transmitter plug is inserted into the jack of an intra-office circuit, a circuit is established from the transmitter to its associated contact on the transmitter allotter.

There are several different types of allotters, but the one in most general use is illustrated in Figure 18. It has 188 contacts arranged in a circle. Inside of the circle is a constantly rotating brush arm that connects ground to the 188 contacts one at a time. This particular allotter makes one revolution every three and three-quarter seconds. Each intra-office transmitter circuit is connected to an individual contact on the allotter. Thus every plugged-up transmitter waiting for a connection has a momentary ground applied to its circuit once every three and three-quarter seconds.

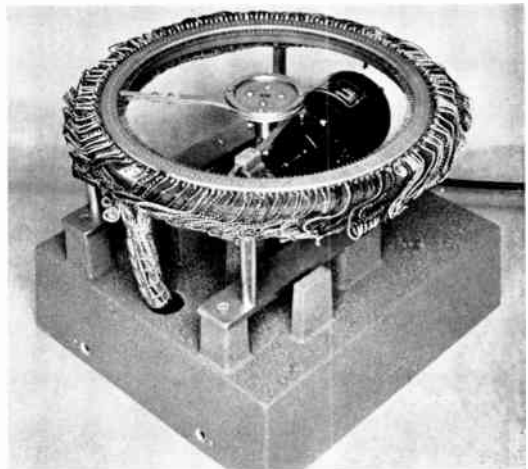

Figure 18. Transmitter allotter

When the transmitter allotter applies ground to the transmitter circuit, a pulse of current will flow if the intra-office circuit is idle. The flow of current causes the transmitter to be electrically connected to the intra-office circuit and immediately "busies" the intra-office circuit.

If a second transmitter is plugged up to this busy intra-office circuit and the transmitter allotter applies ground to the circuit of this second transmitter, no current flows. Thus the second transmitter cannot seize the intra-office circuit until the first transmitter has completed the transmission of its message. When that happens, the next time the transmitter allotter tests through the circuit of the second transmitter, a current flow will result and the second transmitter will seize that intra-office circuit.

Teleprinter Receiving Concentrator

Some teleprinter circuits do not carry a sufficient load of messages to warrant the assignment of an exclusive receiving

position. For such circuits concentrators are used. (See Figure 19.) The ratio of circuits to positions depends upon the anticipated peak period message load. Receiving concentrators are designed to provide for a maximum of twelve circuits concentrated into four printer-perforator receiving positions (on one side of an eight-position switching turret). In practice it has been found desirable to limit the number of circuits to about ten per concentrator in order to give prompt connections during peak periods of simultaneous demands.

When an out-station wishes to transmit a message, a calling signal is sent over the line by striking the "letters" key of the teleprinter. This signal sets up a calling condition in the concentrator at the switching office. If all four printer-perforators are busy, the call is stored. When a printer-perforator becomes available, it connects to the calling line. If one or more printer-perforators are idle, the lowest numbered one connects to the calling circuit. A "Go Ahead" signal, consisting of

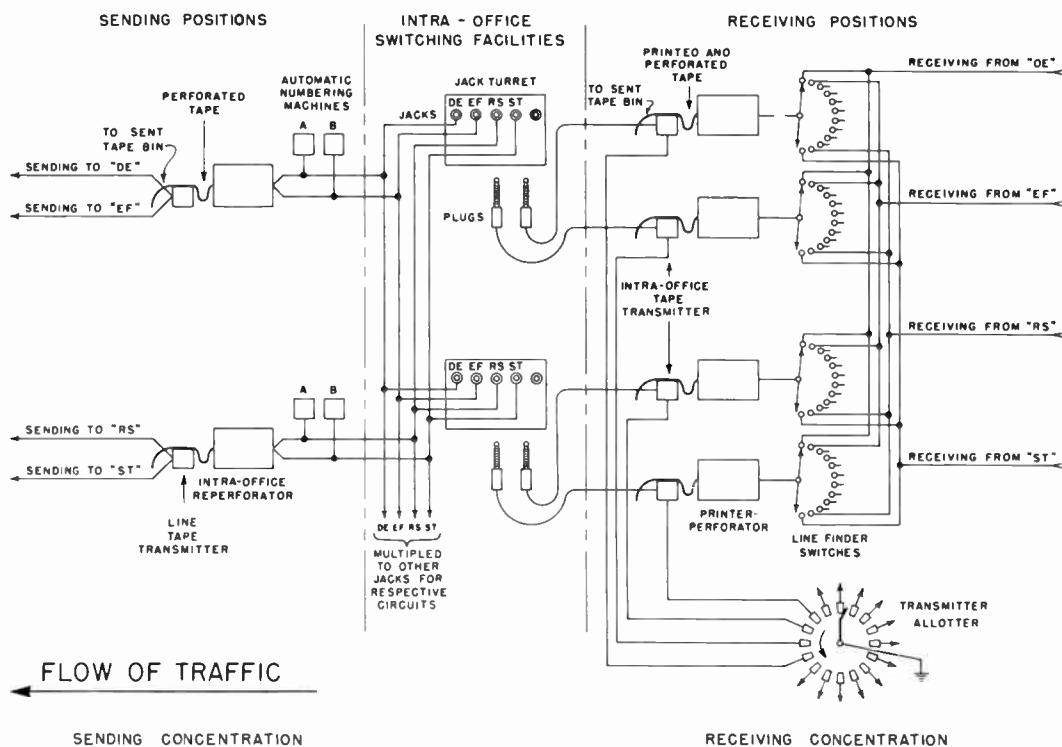

Figure 19. Receiving and sending concentration

an eight-tenths second opening of the sending circuit, is sent to the out-station. This signal is "read" by means of a timing unit at the out-station and a "Go Ahead" lamp is lighted.

The out-station then may send as many messages as it desires. When it is through sending, it terminates the last message with five "blanks" (code combinations in which all five pulses are spacing). These five blanks serve as a disconnect signal to the concentrator at the reperforator office. A "Timed Open" signal of two seconds duration is sent back over the sending circuit, and the timing unit at the out-station responds to this signal and extinguishes the "Go Ahead" lamp. The circuit is then disconnected from the printer-perforator.

If an out-station fails to transmit after securing a connection, or stops during transmission for a period of 15 to 20 seconds, the circuit will be disconnected automatically. This prevents an out-station from accidentally or carelessly wasting concentrator capacity.

Teleprinter Sending Concentrator

Some teleprinter line sending positions are so arranged that they serve two lightly loaded line circuits instead of one. These are known as two-station teleprinter concentrators. Out-station receiving equipment is the same as used at out-stations which receive from an unconcentrated teleprinter sending position.

In the switching unit, there is a separate intra-office path for each of the destinations served by one of these positions. These paths are complete in all respects except that they both terminate in the same reperforator. The line transmitter at these positions has a circuit arrangement which reads the first character of each message as it is being transmitted to line. Normally the line transmitter is connected to the first or "A" circuit. Therefore, no selector signal is needed on messages transmitted to the "A" circuit. All messages go to that circuit unless the character "space" (third pulse marking) appears as the first character of the message.

When a message is switched over the intra-office path of circuit "B", an intra-

office circuit arrangement functions, causing a relay combination to transmit a "space" character into the intra-office reperforator. The automatic numbering machine then functions and the telegram follows. When the line transmitter transmits the "space", the associated reading device (which functions only on the first character of a message) causes the transmitter to connect to circuit "B". When transmission of each message is completed to "B", the two-period end of message signal disconnects circuit "B" from the transmitter and reconnects circuit "A". If the next message is destined to "B", the above process is repeated. The automatic numbering machine in the intra-office path to circuit "A" prefixes its sequence numbers with the letter "A" and the automatic numbering machine in the intra-office path to circuit "B" prefixes its numbers with the letter "B".

Way Stations

Way circuits having two or three out-stations are terminated in the reperforator switching unit. These circuits can be operated in only one direction at a time. All messages over these circuits in both directions are received at all of the stations on the circuit. Messages are numbered in sequence to each office.

The line circuit is terminated at the reperforator office in a single line repeater set and separate receiving and sending legs are extended to receiving and sending positions in the switching unit. (See Figure 20.) The receiving position is similar to other receiving positions except that a separate number sheet is maintained for each of the way offices. Since the line circuit can be operated in only one direction at a time, the circuit arrangement is such that the line sending transmitter is prevented from operating by a vacuum tube timing arrangement when incoming signals are being received from an out-station.

There is a jack in each switching turret for each of the offices on a way circuit. The line sending position is similar to a one-station line sending position except that three numbering machines are pro-

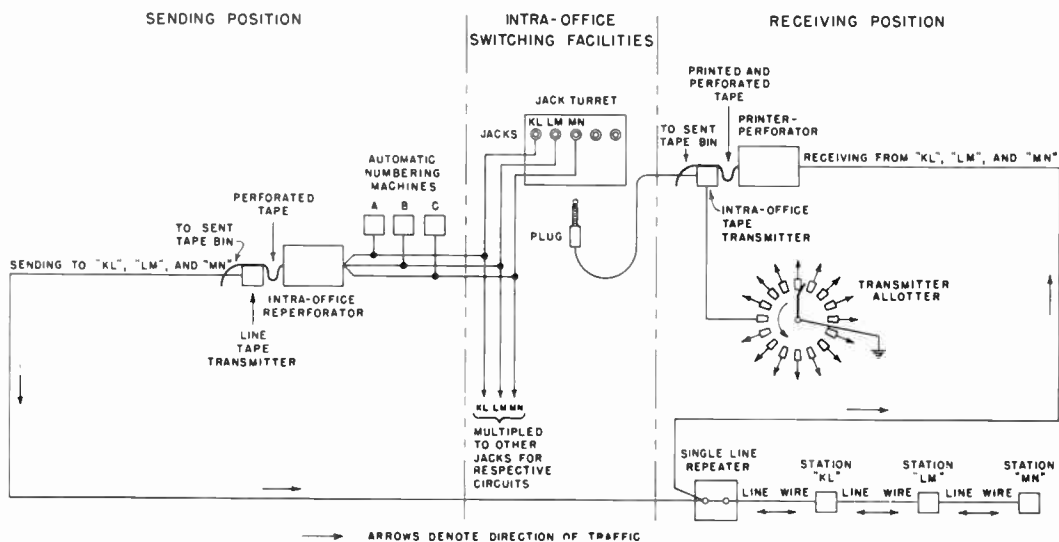

Figure 20. Way-circuit switching

vided. These numbering machines are set up for A, B, and C number series. When a message destined to the first station is switched into the sending position, the A numbering machine functions. For the second and third stations, the B and C numbering machines function, respectively. Thus all messages sent to the first station are numbered in sequence A1, A2, A3, etc., while all messages to the second and third stations are in sequences B1, B2, B3 and C1, C2, C3, etc., respectively.

Supervisory Controls

In a system that is so largely automatic, numerous supervisory controls are required to maintain a constant check on the movement of traffic and the proper functioning of circuits and apparatus. In Figure 21, a switching turret is shown with two receiving positions on either side of it. Many items other than the printer-perforators, transmitters, cords and jacks described in the first article are shown.

Receiving Signal and Control Unit

On receiving positions there are signal and control units containing various signal lamps, push-buttons and control switches. These units, which are mounted

directly above the transmitter, vary slightly for multiplex and teleprinter receiving positions. Figure 22 shows the unit used on multiplex, and Figure 23 shows that used on teleprinter positions. Each lamp, push-button and switch described in the succeeding paragraphs is shown and designated in these figures.

Message-Waiting Lamp: When the out-station starts transmission, the message-waiting lamp glows steadily, thereby indicating an unswitched message at that position. When the telegram has been completely received, and if no succeeding message is being received, the lamp may be extinguished by depressing the "Feed Out" push-button in the tape-control unit, described later. The receipt of bell signals from the out-station (calling for extraordinary attention) will cause this lamp to "flash". The flashing may be stopped by depressing the push-button located just below the message-waiting lamp.

Low-Tape Lamp: Tape reels which hold the tape supply for each printer-perforator, have a pair of contacts which are normally held open until the tape roll nears its end, when they close and complete an electrical circuit. This closure causes the low-tape lamp to glow.

Four-Bell Push-Button: The switching clerk depresses this button in order to transmit the four-bell "stop" signal over

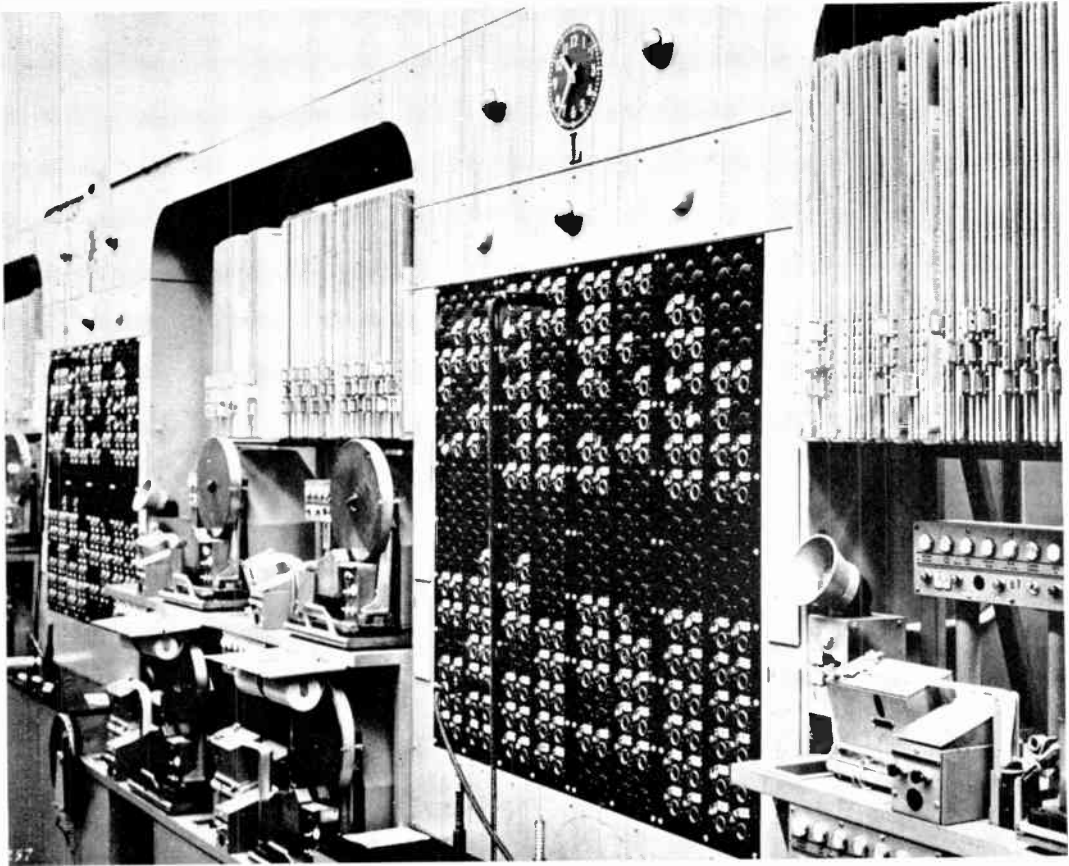

Figure 21. Line receiving position and jack turrets

a multiplex circuit when for any reason it may be found necessary to request the out-station to stop sending. It will be noted that this push-button is not used on teleprinter circuits.

Tight-Tape Lamp: A small lever arm, pivoted at one end, is mounted in the top of the tape neck leading down to the tape accumulator described in the first article. This tape neck and its lever arm are located between and somewhat lower than the punch block of the printer-perforator and the top of the intra-office transmitter. The tape passes under this lever arm and when the tape between printer-perforator and transmitter tends to become taut due to the fact that most of the perforated tape has passed through the transmitter, the lever arm is raised. Raising the lever arm closes cooperating contacts which stop the transmitter before the tape becomes taut and will not allow

the transmitter to start again until more tape is received from the printer-perforator and the lever arm falls. This condition may occur in the middle of a message being transmitted across the office; for example, if the last message received by the printer-perforator should be switched without stepping out enough blank tape behind it to allow the last character of the telegram to pass over the pins of the transmitter. When that occurs, the lever arm will stop the intra-office transmitter, light the tight-tape lamp, and cause a buzzer signal to sound. The switching clerk can extinguish the lamp and stop the buzzer by depressing a "tape feed-out" button as described later.

Intra-office Tie-up Lamp and Tie-up Release Button: Transmission of messages over the intra-office facilities is very reliable. Occasionally, however, tape may fail to move through an intra-office reper-

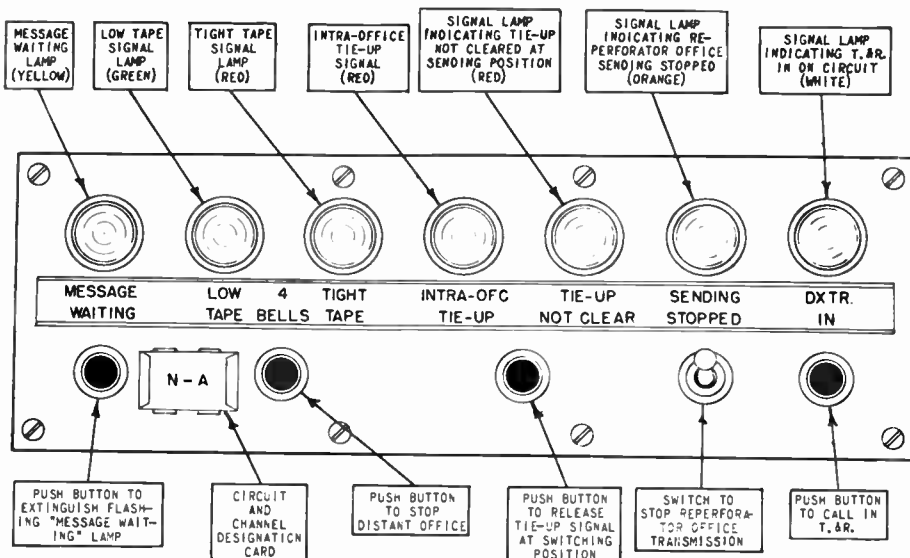

Figure 22. Multiplex signal and control unit

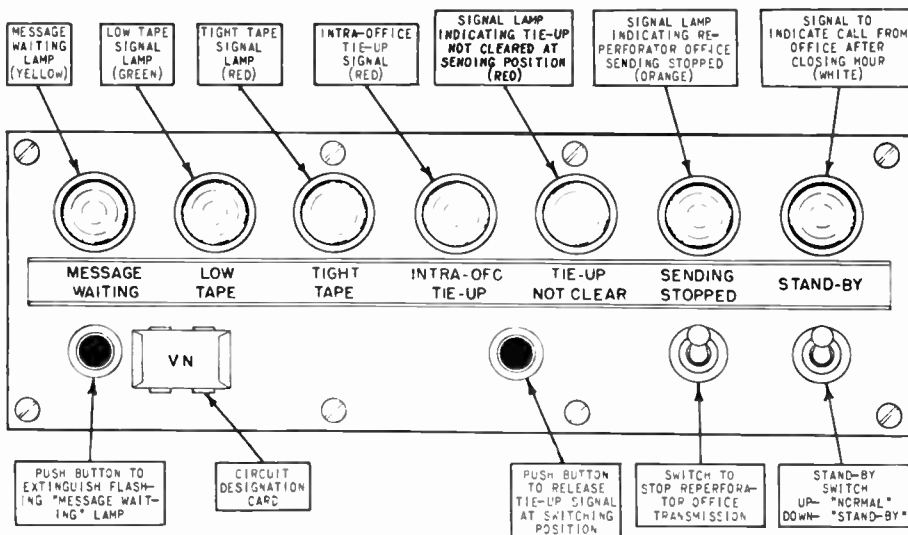

Figure 23. Teleprinter signal and control unit

forator when a message is being received. A "tape tie-up" system functions at such times. Normally the tape pulls from the tape reel and moves through the reperforator during reception of a message. In so doing it travels around a roller fastened to a shaft and, as a result, both the roller and shaft turn. A cam with cooperating contacts is fastened to the shaft and the

contacts open and close frequently when the tape moves normally. The contacts are connected to an electronic timer and this timer holds a relay operated as long as the contacts are actuating and signals are being received over the intra-office circuit. If the tape ceases to move (while signals are being received over the intra-office circuit) the electronic timer, after ap-

proximately a two-second interval, will cause its relay to release, thereby operating the tape tie-up alarm. The operation of this alarm causes tape tie-up lamps to glow at the line sending position and at the line receiving position from which the message is being sent. The intra-office connection will be maintained. Upon instruction from the sending aisle supervisor, the switching clerk resets the tape in the intra-office transmitter at the beginning of the message. She then depresses the tape tie-up release button in the signal indicator and this action conditions the intra-office transmitter circuit so that it will automatically start when suitable action has been taken at the line sending position.

Tie-Up Not Clear Lamp: As indicated above, when an intra-office tie-up condition occurs it must be cleared by action at both the line receiving and the line sending positions. These positions generally are widely separated in the switching unit. If the switching clerk clears the trouble at her position by resetting her tape to the start of the message and depressing the tie-up button, the tape tie-up lamp will be extinguished, but if the supervisor at the sending position has not yet cleared the trouble at that end of the intra-office circuit, the "tie-up not clear" lamp at the receiving position will glow, indicating to the switching clerk the reason why her transmitter does not re-start immediately.

Sending-Stopped Lamp and Sending-Stopped Switch: At times a distant station wishes the reperfector switching office to stop sending to it, and indicates this fact by transmitting four-bell signals. When this occurs, the switching clerk can stop the line transmitter (in the sending section of the office) by throwing the "sending-stopped" switch at her position. When this is done, the sending-stopped lamp at the switching position will glow.

Distributor-In Button and Lamp—(Multiplex circuit only): When the switching clerk or supervisor notes a condition indicating the need for a distributor attendant to come in on the circuit, she depresses the distributor-in button. This causes a signal light to glow and a

buzzer to sound in the Testing and Regulating section of the operating room, calling an attendant to that circuit. When the distributor attendant comes in on the circuit (either as a result of a call as indicated above, or for other reasons), the distributor-in lamp will glow.

Stand-By Lamp and Switch—(Teleprinter circuits only): When a teleprinter line circuit goes open it is desirable to disconnect the printer-perforator from that circuit so that it will not continuously feed out tape. When this is done, the stand-by switch is thrown in the down position and a signal lamp and buzzer are thereby connected to the circuit. The signal lamp will glow and the buzzer will operate when the teleprinter circuit is restored and operation may be resumed.

Five large lamps are shown in the top of the switching turret (Figure 21). The lamp on the upper left is the low-tape lamp, common to all receiving positions in that turret, and it will glow when any of the low-tape lamps which are mounted at the individual receiving positions of that turret glow.

The lamp on the upper right is used as a signal to call a regulating attendant to that position when needed. It is operated from a switch mounted on the side of the turret. The lamp on the lower left is the message-waiting lamp common to all receiving positions on the left side of the turret. The middle lower lamp is a tape tie-up lamp common to all receiving positions for the turret. The right lower lamp is the message-waiting lamp common to all receiving positions on the right side of the turret.

A microphone connected to an intra-office broadcasting system over which the switching clerk can talk to various sections of the switching unit, and the "busy" lamp and selector push-button mounted in a box below the microphone are shown to the right of the turret and to the left of the signal indicator panel.

To the right of the intra-office transmitter may be seen a small box containing two push-buttons. The push-button on the left, when depressed, causes the feeler pins of that transmitter to be withdrawn so that the tape may be pulled through

the transmitter freely. The push-button on the right, when depressed, causes the printer-perforator to eject a measured amount of blank tape in order to allow the last perforated character to pass through the transmitter.

Sending Signal and Control Unit

On line sending positions, directly above each line transmitter, is a signal and control unit containing various signal lamps, push-buttons and control switches. This unit is associated with the automatic numbering machine, reperforator and line transmitter on the sending side of each circuit or channel. The unit shown in Figure 24 contains the signals and controls on both multiplex and teleprinter circuits. A line jack is provided for Testing and Regulating use on teleprinter circuits. The signal and control unit will have one or more busy keys, depending on the type of circuit.

Reading from left to right the signals and controls are as follows:

Three-Position Busing Key: This key is the means by which the sending position is opened or closed to the reception of traffic through the intra-office circuits from switching positions, and it controls the corresponding neon lamps at the

switching turrets. The central position of this key, marked "Open", is the normal working position when the sending position is open for traffic. The corresponding neon lamps in the switching turrets do not glow when the busy key is in the "Open" position.

When the key is in the down or "Closed" position, the sending position is busied. If an attempt is made to secure a connection at a switching turret to a circuit on which the sending position has been busied (or if it is a multi-channel circuit on which all of the sending positions have been busied), the switching transmitter will not start. It is therefore impossible to switch traffic to a closed position. When the busy key is placed in the "Closed" position, the operation has no effect on the message then being reperforated, but prevents further connections into the sending position after the first switching control signal. When the busy key is in the closed position, the corresponding neon lamps in all switching turrets are caused to glow steadily (except on circuits having more than one channel where the neon lamps do not glow until the busy keys on all channels of a circuit have been closed).

When the busy key is placed in the up or "Special" position, the neon lamps in the switching turrets will flash continu-

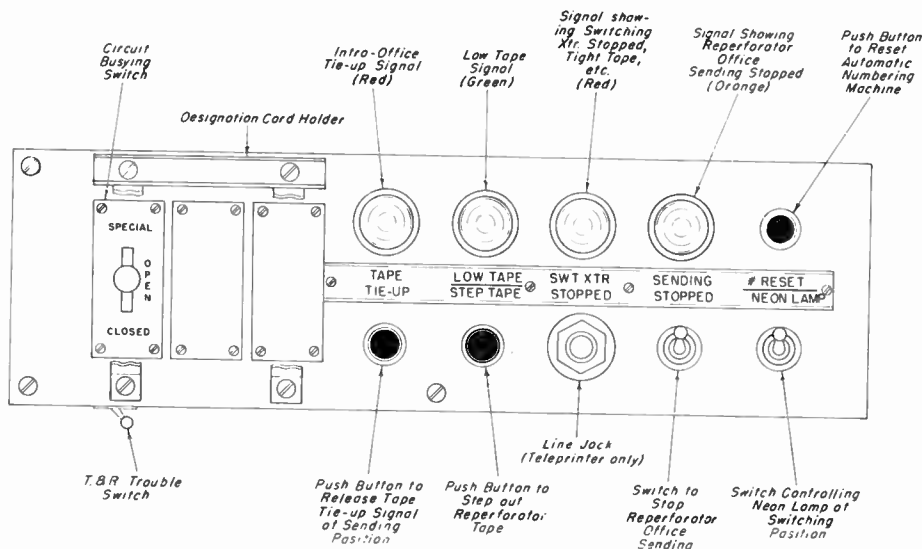

Figure 24. Sending position signal and control unit

ously. Connections may be made from the switching turrets in the usual way. However, the flashing of the neon lamps when the key is on "Special" signifies that special routing instructions are effective on that circuit. On multi-channel circuits the neon lamps flash when the key on any one of the sending positions is placed to the "Special" position. A toggle switch permitting further control of the neon lamp is described below.

T. & R. Trouble Switch: A toggle switch located on each sending table, usually on one of the signal and control units underneath the three-position busying switch, is used to call in the aisle T. & R attendant. When moved to the "On" position it operates the red "Trouble" lamp mounted on the sending table, the aisle "Trouble" lamp, and a signal located on a T. & R. work bench.

Tape Tie-up: The red "tape tie-up" signal lamp glows when there is a tape tie-up into the position. The "switching transmitter stopped" lamp, described later, is also lighted, as well as the red "Trouble" lamp mounted on the sending table. The red "Trouble" lamp directs the sending supervisor to the location of the position in trouble. When the trouble has been cleared and the reperforator is again ready for operation, the signal is released by depressing the push-button located below the "tape tie-up" signal lamp. The switching transmitter will not start, however, until the signal at the switching turret has also been released. All tie-up signal lamps will be extinguished when the tie-up buttons have been depressed at both the sending and switching positions.

Low Tape: This green signal lamp indicates the need for a new roll of tape in the reperforator. The busying key must be moved to the closed position while a new roll is being placed in the reperforator. To direct attention to the position, a green "low-tape" signal lamp is also mounted on top of each sending table. This signal, as well as a centrally located green signal lamp, operates when the "low-tape" signal appears on any of the positions associated with a sending table.

Step-Tape Push-Button: Located below the "low-tape" signal lamp is a "step-

tape" push-button. The reperforator will step out blank tape as long as this push-button is held depressed. The push-button is used when threading tape through the reperforator punch block and at other times when it is desired to feed tape out of the reperforator. It is ineffective when the reperforator is in operation. An automatic tape feed-out device is provided on each reperforator which causes it automatically to feed out enough blank tape, when the sending position is clear, to pass the last message through the transmitter.

Switching Transmitter Stopped: This red signal lamp glows when the switching transmitter is stopped, during the transmission of a message, by operation of the tape-pull push-button or the tape lever stop arm at the switching position. The switching transmitter stopped signal also glows when there is a tape tie-up into the reperforator.

Line Jack: A line jack located under the switching transmitter stopped signal lamp on teleprinter circuits only, permits the T. & R. attendant to test transmission on the line from the reperforator office.

Sending Stopped: The "sending-stopped" toggle switch is used to stop the line transmitter at the sending position. When the transmitter is stopped, the "sending-stopped" signal lamp above the toggle switch glows. A corresponding signal lamp and switch at the switching position is described above. The line transmitter may be stopped from either the switching or sending position, but may be started at the sending position only.

The "sending-stopped" signal lamp on a local reperforator sending position will operate when the associated "sending transmitter stop key" is operated at the receiving position in the local section (where messages are converted to hard copies by gumming printed tapes to receiving blanks).

Number-Reset Push-Button: Depressing this push-button automatically resets the numbering machine to number "00" or "000", depending on whether it is a two- or three-digit numbering machine. On way circuits and sending concentrator positions, this button simultaneously re-

sets all numbering machines associated with that position.

Neon Lamp Switch: By operating this switch to the down position, the corresponding neon lamps mounted over the jacks in each switching turret will glow steadily. The three-position busying key is then placed to the "Special" position, as a reminder to the sending supervisor that the neon lamp switch is not in its normal position. This switch is used by supervisors and T. & R. attendants when it is desired that regular traffic shall not be switched into a sending position.

Supervisor, File, and T. & R. Positions

Communications are received which are directed to the attention of the supervisory or testing and regulating personnel of the switching office. Switching clerks switch them to jacks in the turret marked "Supervisors" and "T. & R." These messages are transmitted into a sending position which retransmits them to supervisors and T. & R. printers.

Incomplete messages which have been cancelled by the outside office (by terminating them with "Bust This"), are sometimes received at switching positions. While such tape could be pulled through the transmitter by the switching clerk, errors of judgment might occur, therefore they are switched to a jack marked "file". These tapes are transmitted to a sending position which retransmits them to a "file" printer. Here a supervisor looks them over and makes certain that they can be discarded with safety.

Three-position concentrator sending positions are used for supervisor, and for file and T. & R. positions. No numbering machines are used. The transmitter is arranged to read "two periods" and then determine by the next character to which of the three printers that communication should be sent.

The intra-office reperforator circuit is arranged so that when a connection is made to one of the three jack circuits, a selection character corresponding to that particular jack circuit is automatically transmitted into the reperforator, ahead

of the message. The selection character for the first printer is the second pulse or "equal" sign. For the second printer, it is the third pulse or "space", and for the third printer it is the fifth pulse or "T". This selection character is read by the transmitter and its associated relays, and serves as a switching control to select the proper one of three "supervisor", or "T. & R." or "file" printers within the office.

The supervisory and file printers are equipped with wide ungummed tape. The supervisor makes notations on the tape to indicate that the communication has been acted upon. The T. & R. printers have regular gummed tape so the received messages can be gummed on a blank and retained by the T. & R. man while carrying out the action requested.

Spillover Positions

Auxiliary positions which have been termed "spillover positions" are provided in each area switching center. (See Figure 25). Essentially they are additional switching turrets and receiving positions that receive from intra-office circuits instead of from line circuits. The number of such positions is determined by the requirements of each particular office. Transmission into a spillover position is at a speed of 150 words per minute from the main switching aisle into a sending position and thence at a speed of 65 words per minute into the printer-perforator at the spillover position.

Spillover positions provide a means whereby incoming messages can be switched away from the line receiving positions into a special switching turret for extraordinary handling. This permits grouping certain messages if so desired, at a position from which they may be switched later to the various sending positions. The spillover circuit may be on a single channel basis; that is, have one sending position that transmits to one spillover receiving position, or it may be on a multi-channel basis in which two or more sending positions are provided and the sending positions transmit to the same number of spillover receiving positions.

The sending positions are similar to one-

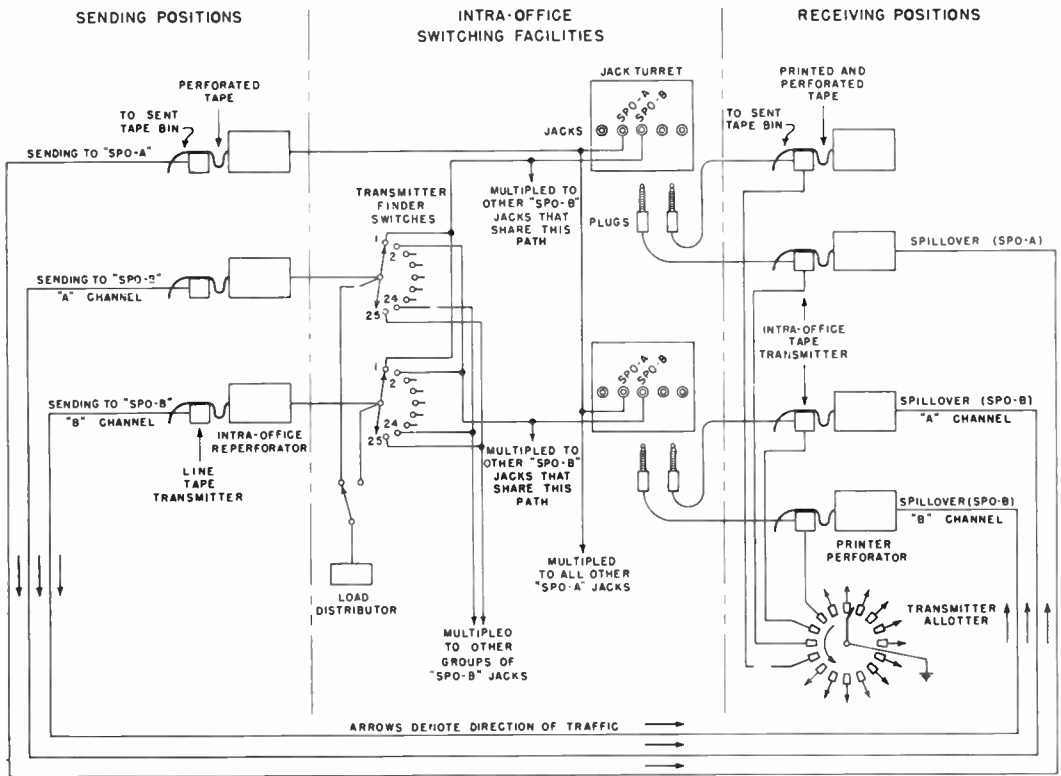

Figure 25. Single and multi-channel spillover positions

channel sending positions except that the automatic numbering machine is generally omitted. Of course, when these messages are reswitched from the spillover switching positions to line sending positions, they will be preceded with the sequence numbers for the particular circuit to which they are switched.

Alternate Routing Board

When line facilities to distant offices are temporarily out of service, it may be necessary at the switching center to route messages to an alternate circuit. The alternate routing board has rotating drums on which the letters of the alphabet are printed. On the face of the routing board are small windows through which the selected letter on each drum can be seen. These drums are actuated from a central supervisory position, to set up the call letters of the closed-out circuits and the call

letters of the alternate circuits to which the messages for the closed-out circuits should be switched. The switching clerk, upon noting that the lamps associated with

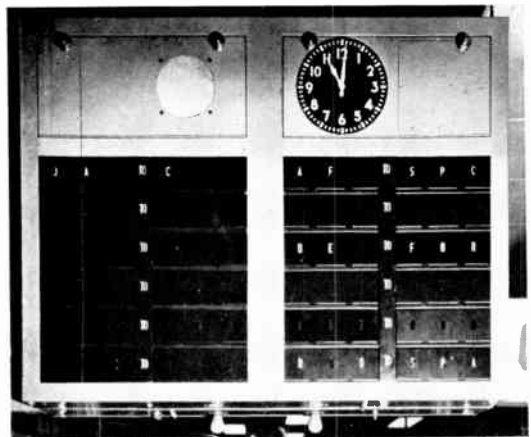

Figure 26. Alternate routing board

the jacks in the switching turrets are lighted on a given circuit, thus denoting that the intra-office path to that circuit is closed out, looks at one of the alternate routing boards (Figure 26) which are suspended from the ceiling at various points in the office to determine the new routing for that message.

This concludes the description of plug and jack switching systems. Subsequent articles will describe push-button switching and other more recent developments incorporated in the installations at Philadelphia and Cincinnati, and the latest type of system known as "automatic switching" to be installed in future offices.

THE AUTHORS: For photographs and biographies of Mr. R. F. Blanchard and Mr. W. B. Blanton, see the January 1948 issue of the **TECHNICAL REVIEW**.

