



**SERVICING  
TRANSISTORIZED  
RADIOS**



**CAT No T-6**

**2/-**



AMALGAMATED WIRELESS VALVE COMPANY PTY. LTD.

# CONTENTS

TRANSISTOR RADIO CIRCUITRY .. .. .	Page 1
DRIFT TRANSISTORS .. .. .	Page 8
SERVICING TRANSISTORIZED RADIOS .. .. .	Page 9
DEFINITIONS AND REFERENCES .. .. .	Page 15
TRANSISTOR RADIO SERVICE TECHNIQUES ..	Page 16

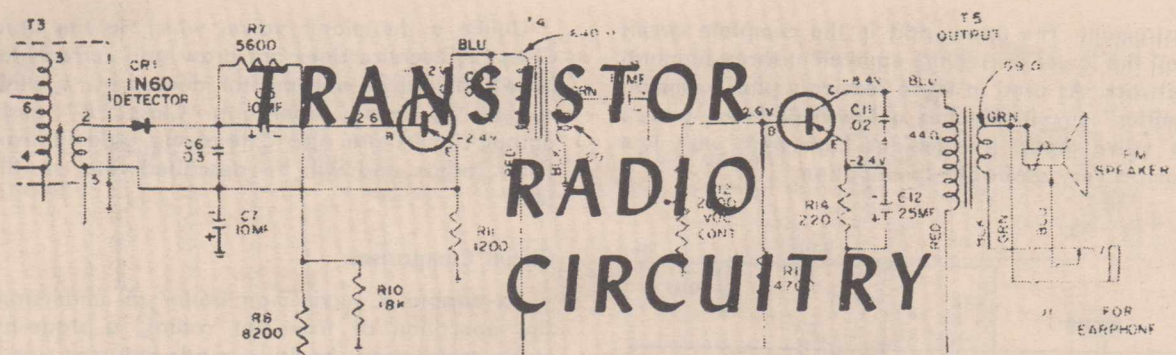

**Introduction**

Servicing of anything becomes easier if we understand how it works. A serviceman must understand the conditions which exist in the circuits of a transistor radio if he is to be able to render efficient service on them.

The serviceman is familiar with the operating conditions which exist in thermionic valve circuits and it will be of great assistance to compare such circuits with transistor circuits. Throughout the text of this article there will be frequent comparisons of circuit conditions and their comparative effect on service problems.

**General Circuit Conditions**

Junction transistors used in transistor radios may be compared with thermionic valves such as type 6C4. In this triode valve there are three active elements: GRID-CATHODE-PLATE. In a transistor there are also three comparable active elements: BASE-EMITTER-COLLECTOR. Signal amplification in both the valve and the transistor is accomplished by applying a small variable voltage to the input circuit in such a manner that it will control the flow of current in the output circuit.

base with an arrowhead represents the emitter. If the arrowhead points away from the base as in Figure 1B it indicates an n-p-n type of transistor. So far as service problems are concerned it only denotes reversed polarity of the terminal voltages and reversed direction of current flow.

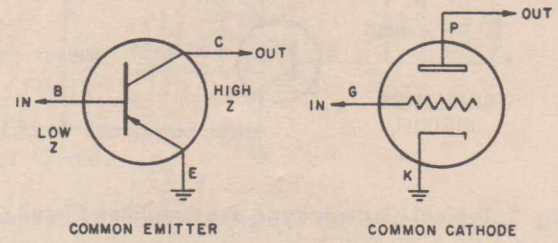

Fig. 2. Transistor Circuit Comparison with Equivalent Thermionic Valve Circuit.

In general, the emitter of a p-n-p transistor can be likened to the cathode of a valve in that it is the source of current flow. The base, more or less controlling the current flow, is equivalent to the grid of the valve. As the collector is the part of the transistor through which the current flow leaves the unit, it can be considered as serving the same function as the valve plate. The elements of an n-p-n transistor serve the identical purposes but the direction of current flow is reversed. The most commonly met transistors are p-n-p types.

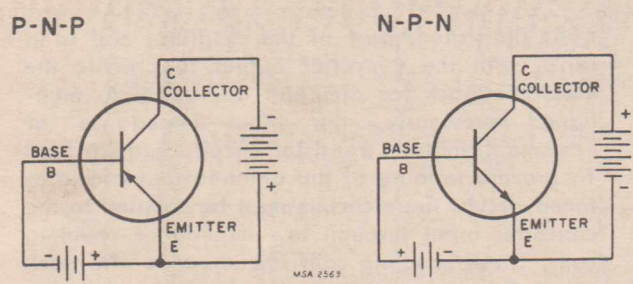

Fig. 1. Schematic Diagrams of Junction Transistors.

Figures 1A and 1B are schematic symbols of junction type transistors. The base element is represented by a heavy short line perpendicular to its connecting lead. The line drawn at an angle to the base without an arrowhead represents the collector and the line drawn at an angle to the

Figure 2 is the most commonly used transistor circuit. It is the "common emitter" circuit and is equivalent to the most widely used valve circuit, that of "common cathode". As used in transistor radios, the "common emitter" circuit has a comparatively low input impedance and high output impedance. Like its valve counterpart, it provides phase inversion.

The transistor circuits which are equivalent to "grounded grid" and "cathode follower" valve circuits are little used in radios, and will not be described in this text.

Figure 3 illustrates the gramophone pre-amplifier circuit used in a typical high-fidelity

instrument. The upper part is the complete circuit and the lower part is the equivalent three-terminal network. As used in these receivers, the "common emitter" circuit matches a low-impedance pickup to valve input. It combines high gain with low hum; a very desirable combination.

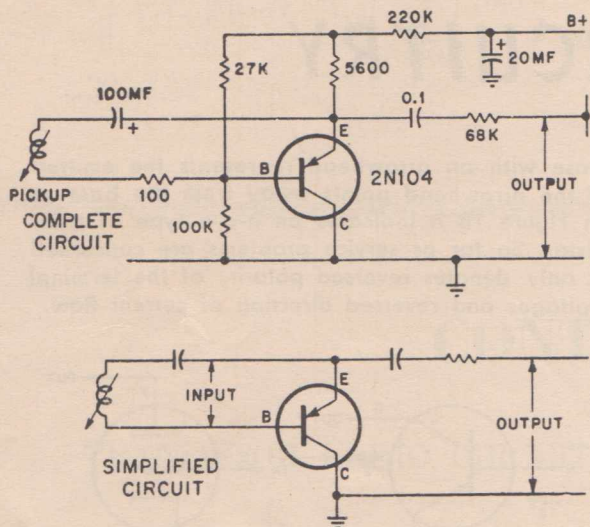

Fig. 3. Typical Gramophone Pre-amplifier Circuit.

### Terminal Voltages

Before proceeding with other circuit conditions, it is desirable that there be a comparison of terminal voltages. In the first place there is no heater or filament to be supplied with power. Secondly, in transistor radios, the normal maximum voltage encountered is only nine volts. However, more important than the maximum voltage is the bias voltage. This is the voltage between base and emitter and corresponds to grid voltage in valve circuits. The bias voltage is of a magnitude of 0.05 to 0.2 volt and is relatively critical. Servicemen who are not accustomed to working with such low voltages may overlook the fact that 0.05 volts  $\pm$  20% amounts to 0.04 volts to 0.06 volts.

The third major difference is polarity. Servicemen are accustomed to positive voltages on the plate and negative voltages on the grid in respect to a common cathode. With p-n-p transistors both the collector and the base voltages are negative in respect to the common emitter. The polarity of n-p-n transistors is reversed — both are positive in respect to the emitter.

In respect to bias voltages of agc controlled transistors, agc decreases the bias voltage (base to emitter) regardless of polarity; with zero bias there is practically no current flow. A transistor behaves much like a sharp cutoff valve. Figure 4 illustrates the relationship between bias voltage and collector current in a p-n-p transistor.

Unlike a thermionic valve, which in the usual Class "A" service does not draw grid current, the base terminal of a transistor does draw a slight current in normal operation. Class "B" audio output circuits are also extensively used in transistor radios and will be described later in this text.

### Circuit Comparison

To enable a serviceman better to understand the operation of transistor radios, a stage-by-stage comparison should be made between circuits of current models of transistor radios and the equivalent thermionic valve circuits.

The first circuit to be compared is the converter circuit. In the commonly used valve pentagrid converter, the oscillator signal is coupled to the antenna signal inside the valve. In the early days of radio, triode converter valves were used and such a circuit is shown in Part A of Figure 5. In both a triode valve circuit and in a transistor circuit, the oscillator signal must be coupled to the input circuit outside of the valve or transistor. A typical converter circuit is shown in part B of Figure 5; this circuit uses an n-p-n transistor.

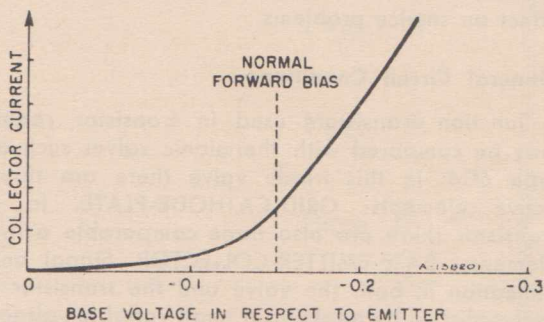

Fig. 4. Bias Voltage vs. Collector Current (P-N-P Transistor).

As illustrated, part of the oscillator coil is in series with the converter output to provide the usual feedback for oscillator operation. As mentioned previously, the input impedance of "common emitter" transistor circuits is quite low. To prevent loading of the antenna and oscillator tuned circuits these circuits must be coupled to the converter input through low impedance coupling coils. These coupling coils are in series with each other. Other converter circuits are similar, differing mainly in voltages and values of circuit components.

In the conventional thermionic valve oscillator circuit, oscillator operation can be checked by measuring the developed dc bias across the oscillator grid resistor. There is no comparable resistor in the transistor circuit. Oscillator voltage must be measured either with an rf voltmeter or a calibrated oscilloscope. There should be an

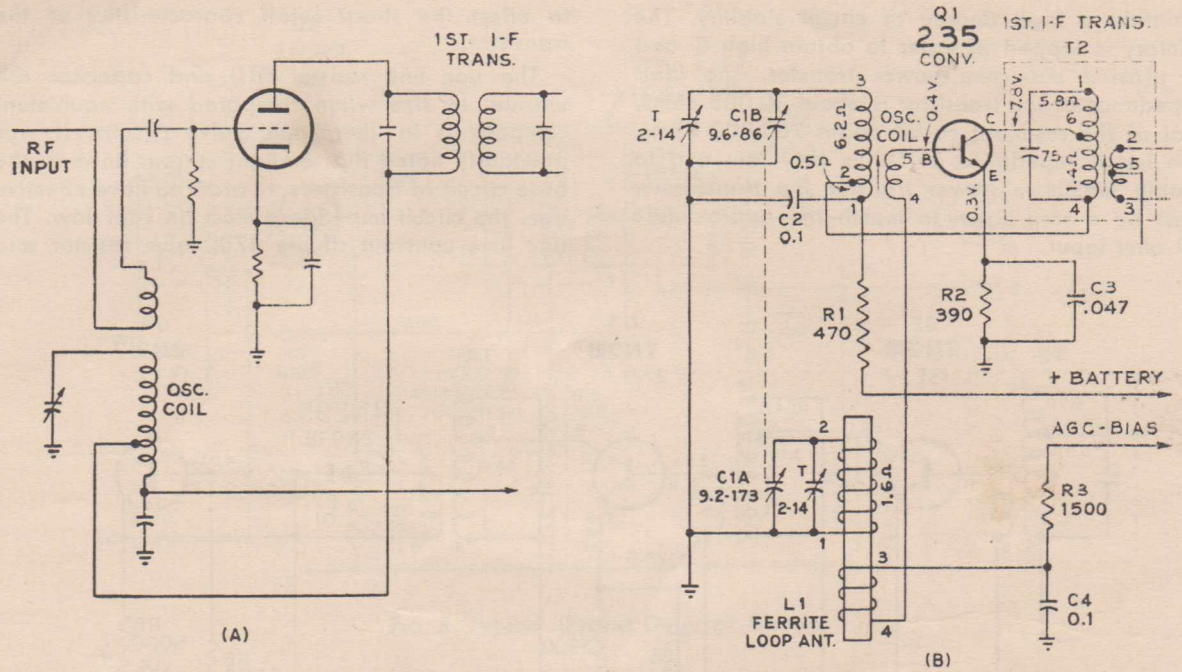

Fig. 5. Transistor Converter Circuit Compared with Triode Valve Converter Circuit.

oscillator voltage of from 0.07 to 0.25 volts rms (0.20 to 0.70 volts pp) at the converter base.

At this point it should be mentioned that although an if signal can be directly injected at the converter input, an rf signal can be injected only by radiating it to the ferrite antenna. The very common practice of touching a finger to a grid to determine if a stage is "alive" cannot be

employed with transistors, because the low impedance input is less susceptible to such circuit loading.

The next circuit to be examined is the if amplifier. Figure 6 is a schematic diagram of a typical if amplifier circuit, also notable in using n-p-n transistors. Two stages of if amplification are used to obtain sufficient gain and selectivity and yet

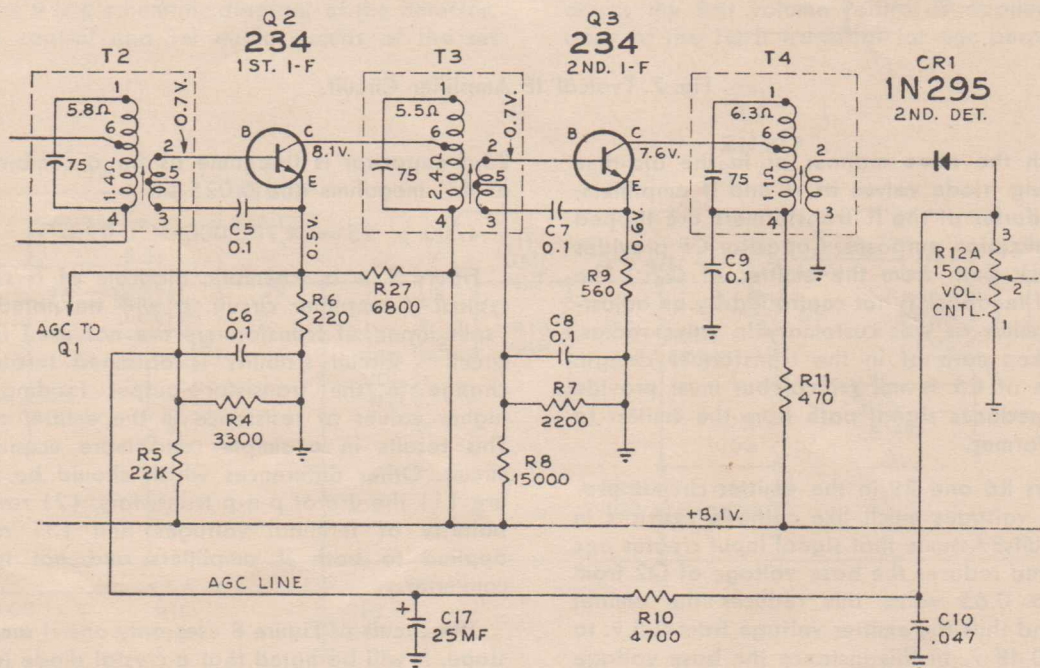

Fig. 6. Typical IF Amplifier Circuit.

maintain a high degree of circuit stability. The primary is tapped in order to obtain high Q and to provide maximum power transfer. The load impedance of the transistor is about 30,000 ohms, that of the resonant circuit about 700,000 ohms. The input impedance of Q2 is very low and to obtain maximum power transfer the transformer must be a step-down to match the approximate 40 ohm input.

to offset the sharp cutoff characteristics of the transistor.

The agc line resistor R10 and capacitor are unusual in size when compared with equivalent components in thermionic valve circuits. It was previously noted that a slight current flows in the base circuit of transistors. In order to have effective agc, the circuit impedance must be kept low. The agc time constant of the 4700 ohm resistor and

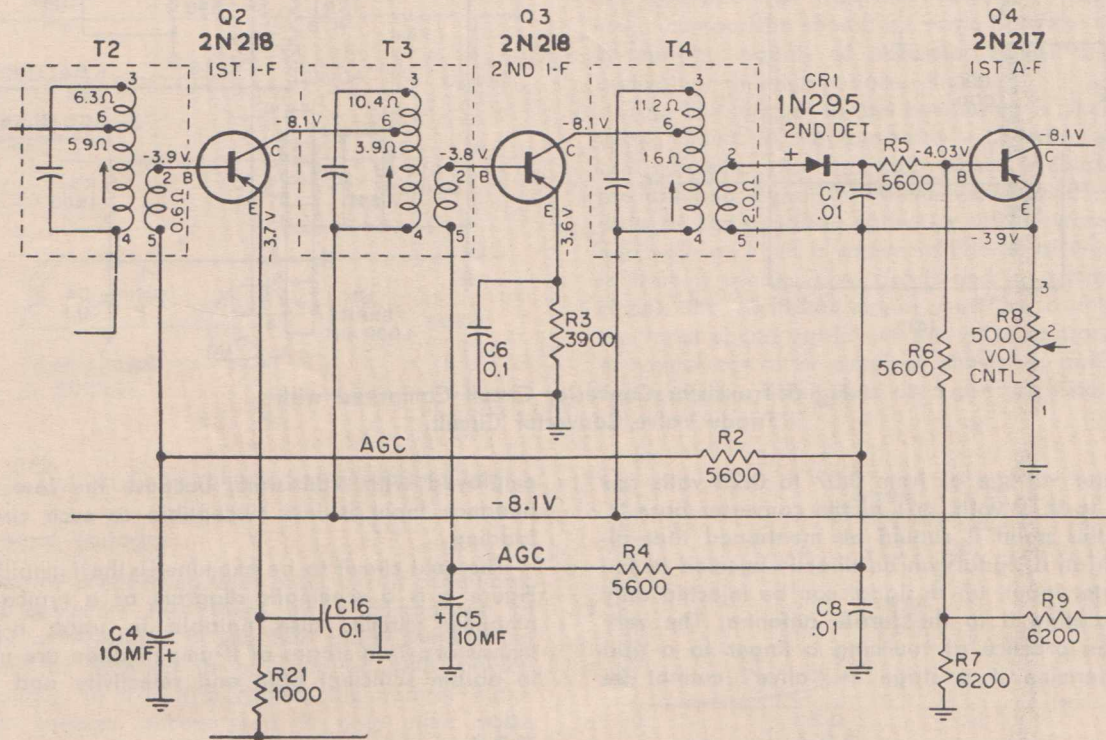

Fig. 7. Typical IF Amplifier Circuit.

In much the same manner as in the old-time radios using triode valves as rf and if amplifiers, the secondaries of the if transformers are tapped for neutralization purposes. Capacitor C5 provides a feedback path from the emitter of Q2. The amount of feedback is not controlled by an adjustable capacitor as was customary in valve radios, but is taken care of in the transformer design. The value of C5 is not critical but must provide a low impedance signal path from the emitter to the transformer.

Resistors R6 and R9 in the emitter circuits provide bias voltages much like cathode resistors in valve circuits. Assume that signal input creates agc voltage and reduces the base voltage of Q2 from 0.7 v. to 0.65 volts; this reduces the emitter current and thus the emitter voltage from 0.5 v. to possibly 0.48 v. In this instance the base voltage has changed 0.05 v. but the bias voltage has only changed 0.03 v. This self-regulating action helps

$25\mu\text{f}$  capacitor is the same as for a combination of 4.7 megohms and  $0.025\mu\text{f}$ .

$$4700 \times 25 = 4,700,000 \times 0.025$$

Figure 7 is a schematic diagram of a second typical if amplifier circuit. It will be noted that "split input" if transformers are not used in this circuit. Circuit stability is obtained through a change in the transistor output loading and higher values of resistance in the emitter circuit. This results in a simpler and more economical circuit. Other differences which should be noted are (1) the use of p-n-p transistors, (2) reversed polarity of terminal voltages and (3) agc is applied to both if amplifiers and not to the converter.

The circuit of Figure 8 uses only one if amplifier stage. It will be noted that a crystal diode is used in this circuit and is designated as "OVERLOAD DIODE". As mentioned previously, transistors have

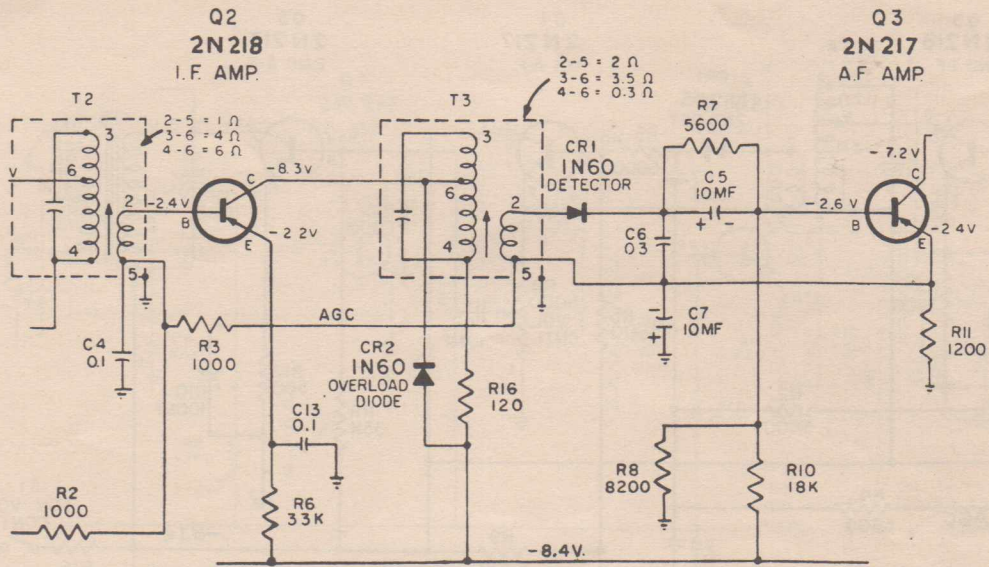

Fig. 8. Typical IF and Detector Circuit.

a sharp cutoff characteristic and this diode is added to give better agc action. The voltage across resistor R16 is about 0.12 volts and delays the conductance of this diode until the signal level is greater than the delay voltage. When the diode conducts, it lowers the Q of the transformer thereby reducing the power gain. The if transformer feeding into the detector crystal diode is very much like the preceding transformers, except that the secondary is designed to match the approximately 2000 ohms impedance of the detector diode.

Figure 9 is a schematic diagram of the detector, volume control and 1st audio circuits of the set

shown partly in Figure 6. A crystal diode rectifier is used as a second detector. The detector action is identical to conventional detector circuits (both crystal diode and thermionic diode). However, since it feeds into a low impedance presented by Q4, a low resistance volume control (R12A, 1500 ohms) is used, a larger demodulating capacitor (C10, 0.047  $\mu$ f) is consequently required and a large blocking capacitor (C11, 10  $\mu$ f) is necessary. A dual volume control is used to provide adequate control of volume in strong signal areas. The rectified signal voltage across the first volume control is applied to the base of the 1st if transistor for agc purposes.

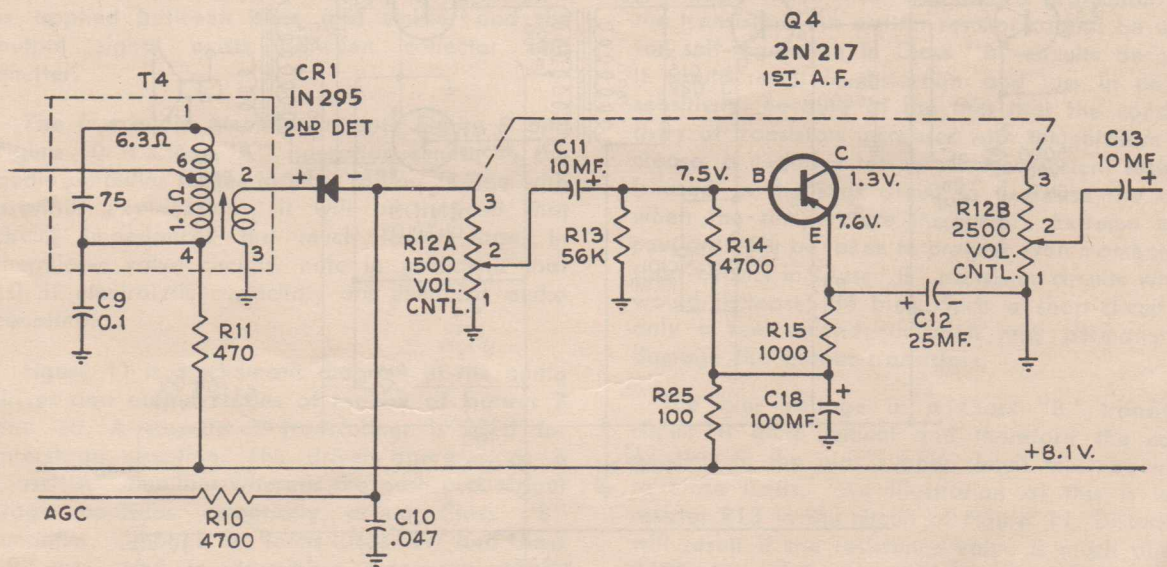

Fig. 9. Detector, Volume Control and 1st AF Amplifier in a Typical Circuit.

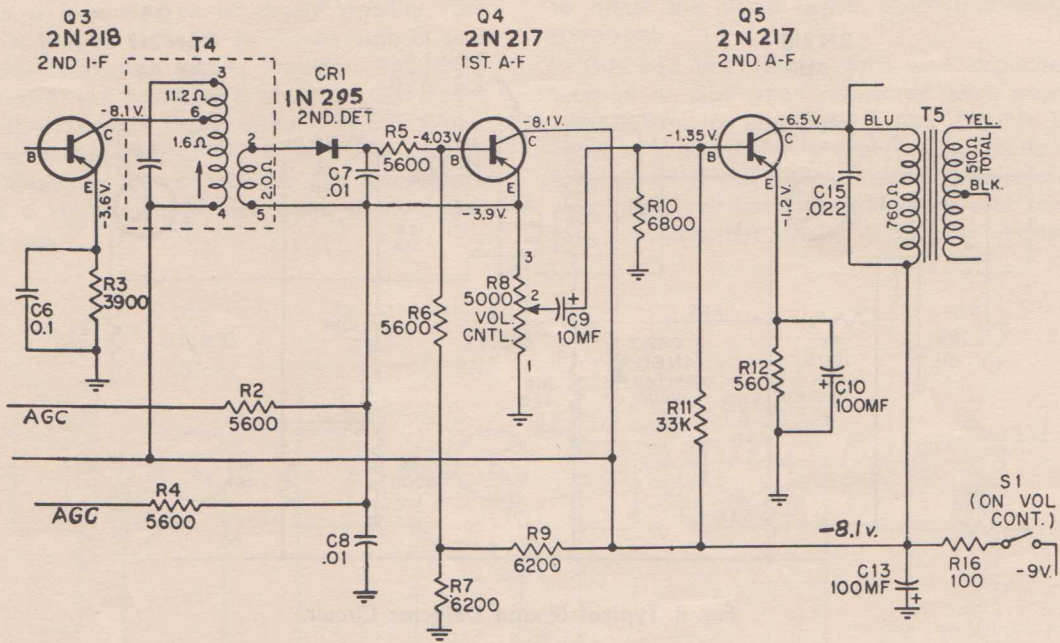

Fig. 10. A Further Typical Detector, Volume Control and 1st AF Amplifier Circuit.

Figure 10 is a schematic diagram of the detector, volume control and 1st audio circuits of the set of Figure 7. There are several significant differences. Because of the use of p-n-p transistors in the converter and if stages, a positive agc voltage must be supplied instead of a negative voltage

as in the previous case. Both ends of the detector diode are above ground potential to enable the proper agc voltage to be supplied to the controlled transistors. The 5600 ohm resistor R5 applies the forward bias which is necessary with crystal diode detectors to improve efficiency and

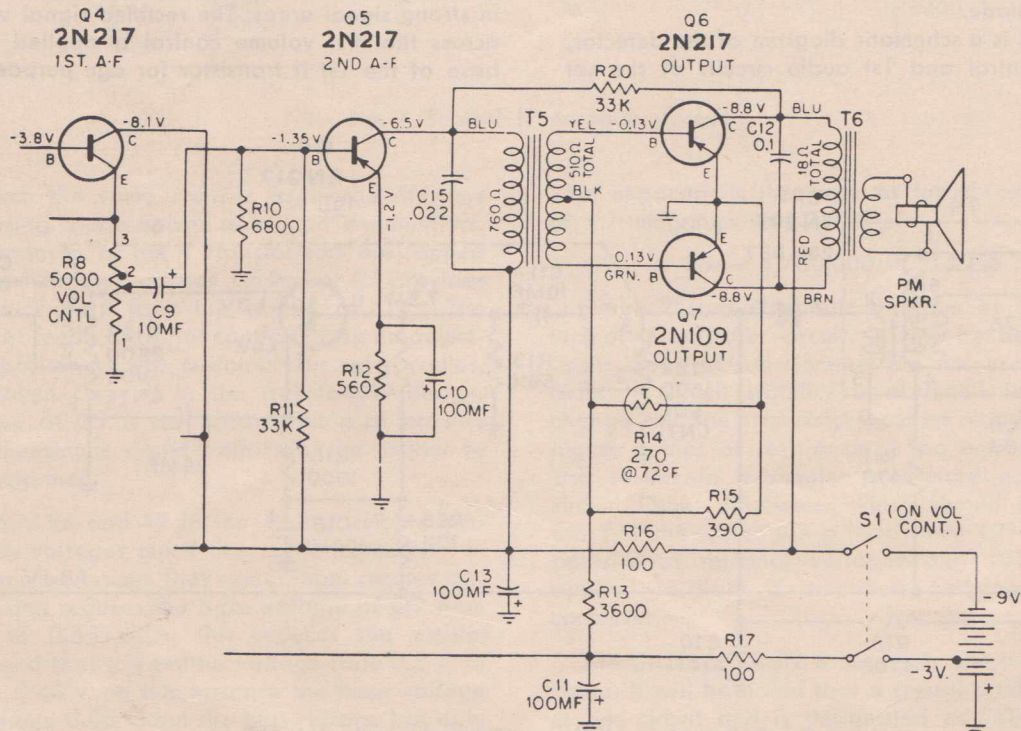

Fig. 11. Audio Driver and Output Circuit.



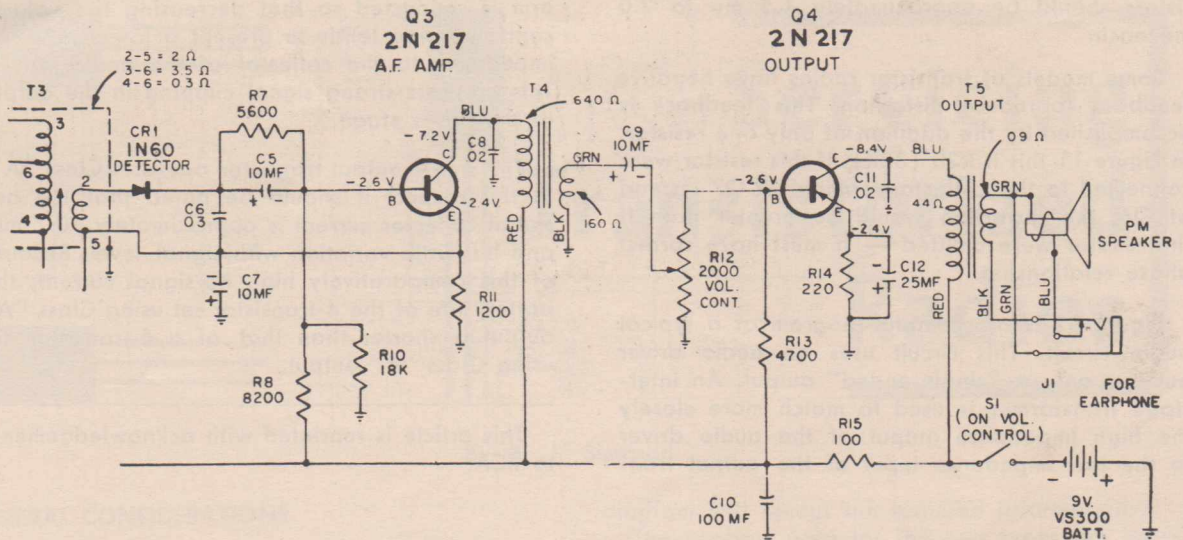

Fig. 12. A Further Typical Audio Circuit.

to prevent low signal distortion. With increased signal the voltage across R8 decreases; thus the agc voltage becomes less negative with increase of signal. At the same time the voltage across R5 increases to maintain a uniform bias on the 1st af transistor.

A second significant difference between the first audio circuits of Figures 9 and 10 is that only a single volume control is used in the latter; this volume control is in the emitter circuit. The collector is connected directly to the battery circuit. Although the collector is at ground potential insofar as audio signal is concerned, this is a "common emitter" circuit since the input signal is applied between base and emitter and the output signal exists between collector and emitter.

The first audio amplifier in both Figure 9 and Figure 10 is Class "A" operation similar to the audio amplifier stages in most radios. In line with previous explanations, it will be noticed that circuit impedances are much lower than in thermionic valve circuits; note in particular that 10  $\mu$ f electrolytic capacitors are used for audio coupling.

Figure 11 is a schematic diagram of the audio driver and output stages of the set of Figures 7 and 10. A step-down transformer is used for interstage coupling. The driver operates as a Class "A" amplifier whereas the push-pull output stage operates essentially as a Class "B" amplifier. Although the terms Class "A" and Class "B" are used in describing transistor circuits because of their similarity to such thermionic valve circuits, it is well to remember that there is a

slight dc current flowing in Class "A" transistor input circuits even with no signal input. The collector current in Class "A" transistor circuits is essentially constant as is the plate current in Class "A" thermionic valve circuits. In Class "B" transistor circuits, the collector current increases greatly with strong signal input in much the same manner as the plate current in Class "B" thermionic valve circuits. The dc resistance of Class "B" input circuits must be low because of this variable current.

The bias voltage supply circuit is quite critical in design. Although the bias voltage must be constant, the circuit must also afford protection for the transistors. An emitter resistor cannot be used for self-regulation in Class "B" circuits because it would result in distortion and loss in power sensitivity. Because of the fact that the conductivity of transistors increases with temperature increase, a negative temperature coefficient resistor is used in the bias circuit to decrease the bias when the temperature increases. Extreme precautions must be taken to prevent even momentary short-circuits in Class "B" transistor circuits which would increase the bias. Such a short-circuit of only a few seconds duration may permanently damage the output transistors.

The bias voltage in a Class "B" transistor circuit is quite critical and therefore the components in the bias supply circuit must be held to close limits. An illustration of this is with resistor R13 in the circuit of Figure 11. Distortion will result if the resistance value is much above 3600 ohms; if the resistor is less than 3300 ohms, the power handling ability is reduced, the no-signal collector current increases and battery

life will be somewhat shortened. The no-signal collector current of the Class "B" output transistors should be approximately 1.5 ma to 2.0 ma each.

Some models of transistor radios have negative feedback to reduce distortion. This feedback is accomplished by the addition of only one resistor. In Figure 11 this is R20 (33K). If this resistor were connected to the collector terminal of Q7 instead of Q6, the distortion would be greater than if the resistor were omitted — it must have correct phase relationship.

Figure 12 is a schematic diagram of a typical audio circuit. This circuit uses an audio driver but has only a "single-ended" output. An inter-stage transformer is used to match more closely the high impedance output of the audio driver to the low impedance input of the output tran-

sistor. The volume control is connected to the secondary of the driver transformer and the centre arm is connected so that decreasing the volume control setting tends to present a lower reflected impedance to the collector of the audio driver. This prevents strong signal clipping in the output of the driver stage.

The single output transistor operates Class "A". In this respect it should be noted that the no-signal collector current is approximately 10.7 ma, and has little variation with signal level. Because of this comparatively high no-signal current, the battery life of the 4-transistor set using Class "A" output is shorter than that of a 6-transistor set using Class "B" output.

This article is reprinted with acknowledgements to RCA.

## Drift

## Transistors

### A NEW CONCEPT IN DESIGN FOR HIGH-FREQUENCY APPLICATIONS

#### About the Name Drift

The word DRIFT is a well-known term in physics used to describe the motion of charged particles in ionized gases under the influence of an impressed electric field. Charged particles move much faster in a given direction by "drifting" in an electric field than they can by random diffusion in the absence of an electric field. Engineers, recognising the analogy between the drift phenomena in gaseous discharges and in semiconductors, applied the word Drift to transistors which incorporate a "built-in" accelerating field.

The electric field in "Drift" transistors, which literally propels the charge carriers from emitter to the collector, is achieved by the graded distribution of an impurity in the germanium base region. This "built-in" accelerating field, a feature not available in conventional transistor designs, results in greatly decreased transit time and therefore a much higher upper frequency limit.

#### The Drift Principle

The successful use of the drift field principle lies in the critically accurate control of impurity distribution in the base region during manufacture. The density of the impurity distribution in the base decreases exponentially from very high values at the emitter to low values at the collector. The impurity distribution introduces a constant electric "drift" field which accelerates (propels) the charge carriers through the base region. Compared with the performance of conventional transistors in which the charge carriers move by means of diffusion — a comparatively slow process because of its random nature — the acceleration of charge carriers by the "drift" field represents a major improvement. Because of the accelerating field in the drift transistor, the transit time of the charge carriers is substantially less than the

(Continued on page 24)

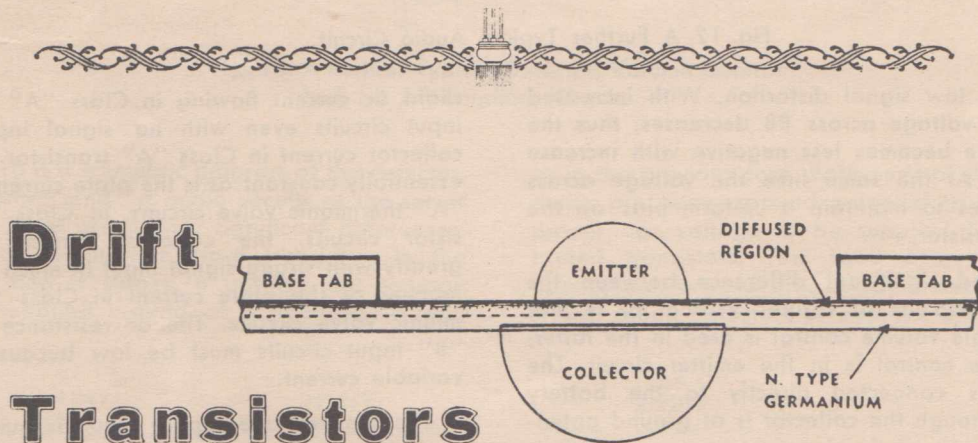

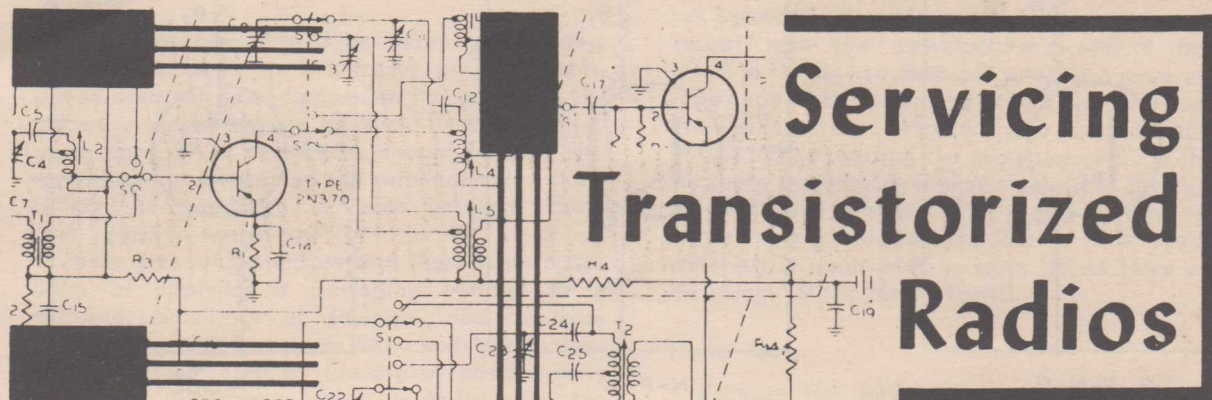

By B. J. Simpson

### GENERAL CONSIDERATIONS

Transistor radios are appearing in ever increasing numbers, and many servicemen approach the first few transistor sets that appear on their bench as a "black box". It isn't a black box — it's still a superhet, with converter, if amplifier, second detector and audio stages. Sometimes there is an rf amplifier stage, and almost invariably to-day, a ferrite rod aerial. Servicemen of greater maturity will recognise an old friend of the 1930's, the Class B audio output stage, brought back into use because of its low no-signal current drain.

The major difference, of course, is the replacement of the thermionic valve with a crystal valve or transistor. Both of these devices perform the same function, but whereas in the thermionic valve, the cathode-anode current flow is regulated by the small grid voltage, in a transistor (Common-emitter circuit) the emitter-collector current flow is regulated by the much smaller emitter-base current. The thermionic valve is thus voltage-controlled and the transistor current-controlled.

Both transistors and thermionic valves are biased, but the application of bias differs in practice. A thermionic valve may be biased to cut off, whereas the transistor is cut off when no bias is applied, that is, the transistor is "forward biased". To put it another way, a thermionic valve is biased to reduce plate current to the required value, whereas the transistor is forward biased to increase collector current.

Before attempting to service transistorized equipment it goes without saying that an understanding is necessary of the transistor and how it works. Another important point is the ability to recognise or identify whether transistors in a set on the bench are p-n-p or n-p-n type as this will, of course, determine the polarities of voltages which one will expect to find in the set, and will influence selection of alternative transistors where necessary. Where the manufacturer's data does not state the type used, an inspection of the circuit

diagram will reveal the required information.

The symbols used for the two types are basically similar, but the arrow on the the emitter connection is pointing towards the base for p-n-p type, away from the base for an n-p-n type. See Fig. 1. Note that some sets use a mixture of the two types.

Alternatively, in the descriptions "p-n-p" and "n-p-n" read negative for n and positive for p; then the required polarity on the collector is given by the centre letter. A check with the circuit diagram may reveal a negative voltage or perhaps 7 to 9 volts on the collectors. From the foregoing then we recognise the transistors in the set as p-n-p types.

The emitter voltage is small, and of opposite polarity (with respect to the base) to that on the collector. It may not be obvious from Fig 1 that the base is the reference, but this is so, and voltages are normally quoted with respect to base. If the collector bias is applied with incorrect polarity, a destructively large current will flow, limited only by the dc resistance in the base and collector circuits. Collector breakdown will occur if the bias (of correct polarity) is applied at too high a voltage. The emitter-base junction is forward-biased. Incorrect polarity may permanently damage some transistor types having a low emitter-to-base breakdown voltage rating.

### SERVICE PRECAUTIONS

Before doing any service work on a transistor radio, all components and wiring should be given an intense visual inspection. Look for broken leads, poor soldered joints, corroded or bent battery terminals, solder or dirt between leads, breaks or cracks in printed circuitry, and similar faults. The largest single reason for service requests on transistor radios is a run-down battery. Test the battery under load, as many circuits are very sensitive to voltage supply.

Transistors are operationally very rugged devices, and when used within the manufacturer's

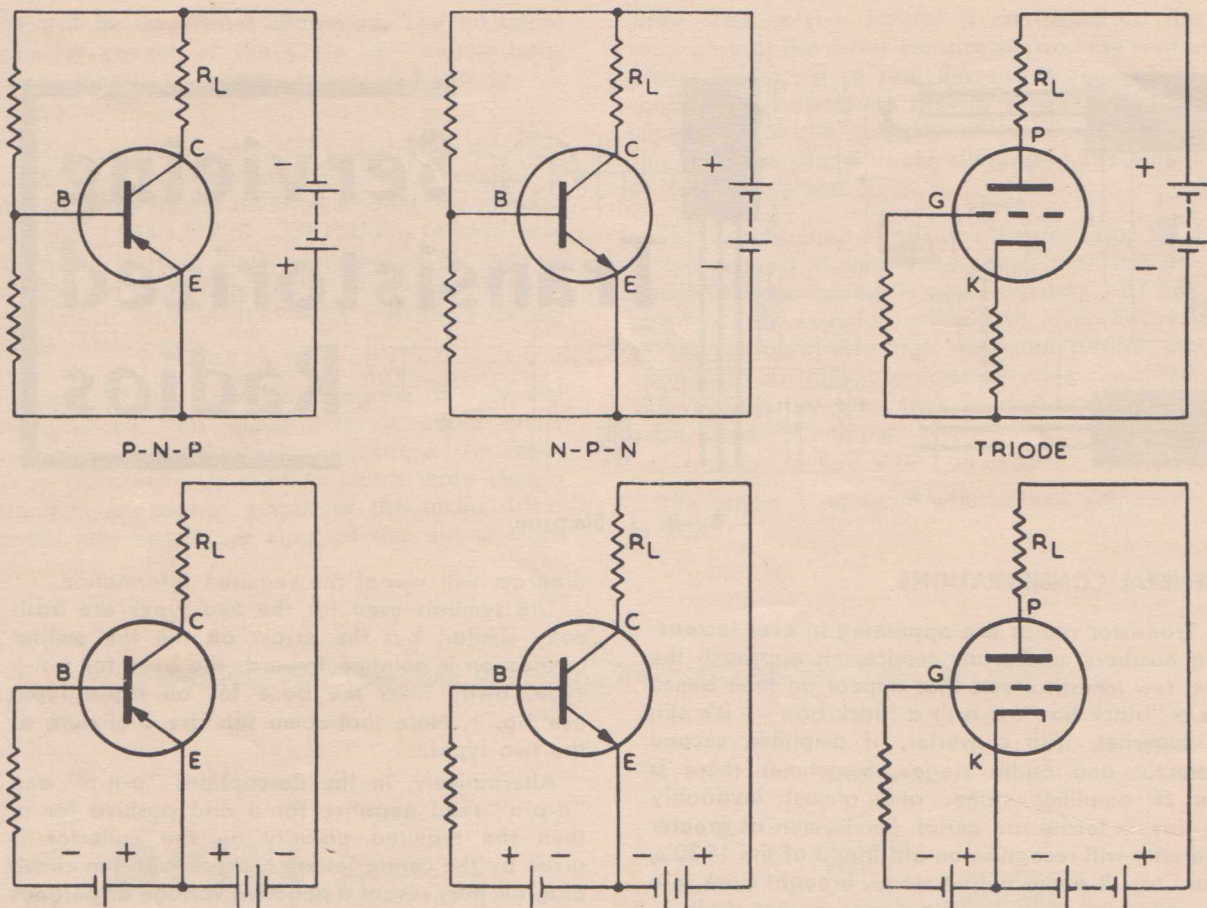

FIG. 1

ratings, may be expected to have a very long life in service. They are, however, easily damaged by careless handling, excessive heat and by the application of incorrect potentials and currents. A number of precautions must be taken in the servicing of transistor radios, and a number of practices long common in the testing and repair of thermionic valve sets must be discarded. The well-known practice of shorting out components in the set to check whether certain stages are operating will certainly lead to damage, by shorting out transistor bias resistors, generating damaging surges, and other effects. This will leave the serviceman with the more difficult problem of repairing both the original fault plus those he has caused himself. The same applies to the attempted measurement of voltages by short-circuiting them with a screwdriver, which would not in any case be feasible, due to the low voltages used in transistorized equipment.

Indiscriminate probing and prodding in the set whilst it is switched on may give rise to damaging current surges. Shorting of transistor connections together or to the chassis will disrupt the bias arrangements and may cause fusing of the transistors by the resulting current surge. No disconnection should be made anywhere in the set whilst switched on. If working on a set employing negative feedback from voice coil to output stage

emitters, the speaker must be connected at all times when the set is switched on. Transistors operate instantly on application of power, and no time is lost by switching off during servicing operations.

The removal or replacement of transistors in a set whilst it is switched on may give rise to damaging current surges. Similarly, the disconnection of one transistor lead whilst power is still applied to the other two connections may ruin the component.

Transistors are sensitive to heat, and temperatures in excess of  $90^{\circ}\text{C}$ . (less than that of boiling water) can cause permanent damage. When soldering transistor leads, always work as quickly as possible and provide a protective heat sink for the transistor by gripping the lead in a pair of "telephone" pliers between the transistor case and the soldering point. If soldering to transistor holders, always remove the transistor during the process. Care must also be taken even when working on other components that the body of the soldering iron is not placed too close to a transistor.

The implementation of the precautions mentioned here requires, among other things, the careful selection of test equipment. The requirements of equipment for use in servicing transistor radios will now be discussed.

## SERVICE EQUIPMENT

### General

The usual care should be taken in providing an efficient earth to the frame of any mains-driven item of test equipment. In addition, the output or input circuits of such items as signal generators, BFO's and CRO's should be such that no voltage is present on the terminals, and there is no low-impedance dc path between "hot" and "earthy" terminals.

These precautions ensure that there is no possibility of applying a damaging voltage to a transistor circuit, or of damaging the transistor by allowing high current to flow. Both precautions can be implemented by the use of good quality capacitors of suitable value in series with the "hot" lead connection.

Assuming an input impedance of 1000 ohms, a suitable value of capacitor would be one offering a capacitive reactance at the operating frequency appreciably lower than 1000 ohms.

### Ohmmeters

Transistors can be damaged by the application of potentials present in many widely-used types of ohmmeter or multimeter. Even when the ohmmeter voltage is low enough to render the instrument safe on transistor circuits, the presence of the transistors in the set can lead to misleading readings when circuit checking. The transistors may conduct under the influence of the applied ohmmeter voltage, and the more reliable procedure is to disconnect the transistors from the circuit when checks of circuit values have to be made. It should be noted that transistor radios are fitted with quite low-voltage electrolytic capacitors, and the open-circuit voltage of many test meters is sufficient to damage these components. The polarity of the ohmmeter leads should be checked, as even the comparatively low voltage used in ohmmeters can damage the low-voltage electrolytic capacitors when applied in the wrong polarity. Transistors also, of course, can be damaged by the application of voltages of incorrect polarity.

An ohmmeter used on a transistor radio must be of the low-current type, and should not pass a current through the external circuit greater than 1 ma on any range. Check this by using a separate low-resistance milliammeter in series with the ohmmeter leads. As regards open-circuit voltage, it is, in general, safe to use an ohmmeter which uses a battery of 3 volts or less, provided a high-ohms range is used. It may be advisable to construct a simple low-voltage ohmmeter for use with transistor sets.

### Voltmeters

Voltmeters used on transistor radios must have a high impedance to avoid misleading results caused by shunting effects, and a voltmeter of

20,000 ohms/volt (50  $\mu$ a fsd) is recommended. In servicing transistor radios, circuit checks using an accurate voltmeter and the comparison of the results with the manufacturer's typical figures given in the service data will provide a more useful indication than ohmmeter checks of the circuit. The voltage checking can also be carried out without disconnecting the transistors, and is therefore more economical in time. Note that the figures given by the manufacturer are generally taken under no-signal-input conditions. This type of checking is dealt with in more detail later when discussing "Static Meter Tests".

### Hand Tools

Because the sets and components are small, and in view of the danger of heat-damage to the transistors, only a small soldering iron should be used, of the order of 30 watts or less. The small "pencil" type instrument irons are admirably suited, and have the additional advantage of operating on a low ac voltage derived from a transformer.

Low insulation resistance between the element and bit of a soldering iron could cause the application of a destructively excessive reverse voltage to the transistor junctions. A low-voltage soldering iron would minimise this risk, even when the insulation is poor, and particularly if a transformer is used which has an earthed shield between windings. Needless to say, the iron bit and casing should be effectively earthed. In general, tools smaller than those normally found in a serviceman's kit will be most useful, including tweezers and "telephone" pliers with very fine points.

### STATIC METER TESTS

Two types of static meter tests are described here, a current consumption test and an individual stage voltage check. The measurement of the total current drain of the set, and then the measurement of the total current drain with each transistor in turn removed from the set in analogous to a check on a valve heating and passing current in a thermionic valve set. It must, of course, be remembered that the fact that a transistor does not draw current does not necessarily mean that it is faulty — the fault may lie in an associated component. The test is, however, easily carried out and at least serves to isolate a faulty stage if nothing more.

Voltage tests at the electrode terminals of the transistors will reveal many types of faults, and at the same time provide a check on the circuitry. Manufacturers of transistorized radios almost invariably quote the electrode voltages on the circuit diagram. Unless specifically stated in the manufacturer's data, make static meter tests with the volume turned fully on, and the set tuned to a spot where there is no active station.

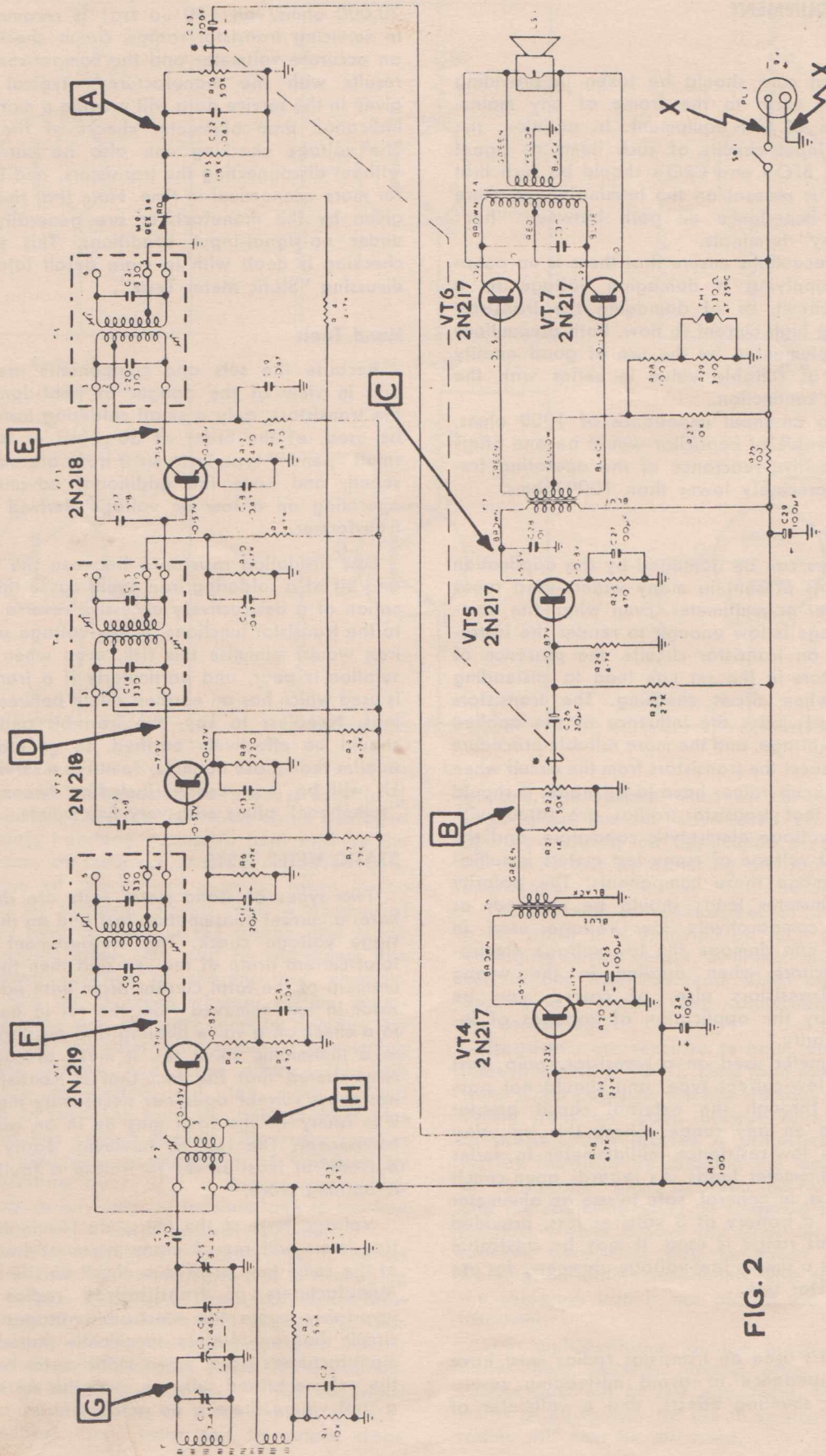

FIG. 2

## CURRENT CONSUMPTION

A typical transistorized radio is shown in Fig. 2. The load on the battery consists of the seven transistors and also several bleed circuits designed to provide various operating potentials throughout the set. The battery load portion of the receiver has been drawn to show the various dc current paths served by the battery, and the result is seen in Fig. 3.

The procedure for this test is to break the battery lead, say at either of the points marked X on the diagram, and insert a milliammeter. Use the highest possible range on the meter. Although the resistance of the meter will probably be quite low, the added resistance in the battery circuit may give trouble, such as audio oscillation in a set with single-ended output stage. Such troubles can usually be eliminated by shunting the meter with a low voltage electrolytic capacitor of fairly high value, observing correct polarity.

If the set is now switched on, the meter will indicate the total no-signal current drain. In the case of the receiver of Figs. 2 and 3, it is approximately 15 ma. The drain is now checked with each transistor in turn removed, switching off the set each time, of course. A fall in total current drain of the order of 0.25 to 1.0 ma should be observed in each case with one transistor removed, depending on battery voltage and other design features of the set. Failure to produce a change in battery current by removing a transistor points to a faulty transistor or components associated with the stage in question.

### Electrode Voltage Check

A high-resistance voltmeter or VTVM may be used to check individual electrode voltages on the transistors in the set, comparing the readings against those published in the manufacturer's data. Note that the published figures are typical figures, to which a reasonable tolerance of say 20% should be applied before assuming a fault. The readings must be made under no-signal conditions unless otherwise stated. A signal input will vary electrode voltages due to increased current drain, agc action, and other effects. Any other circuit voltages quoted in the data, such as at fixed potentiometers, should also be checked out. The polarities as well as the magnitudes of the voltages are, of course, very important, and must be carefully checked.

## DYNAMIC TESTING

It seems likely that dynamic testing will prove even more popular in locating faults in transistor radios than with sets employing thermionic valves. The trend to dynamic testing is given extra impetus by the increased difficulty of making point-to-point circuit checks in transistorized equipment, and by the fact that there is a natural reluctance

to indulge in extensive soldering operations in order to carry out tests. Where printed circuitry is used, the tendency is even more understandable.

It must be remembered that transistors are very robust, and for a transistor to fail of itself is probably rare. Failures can usually be attributed to an outside cause, such as heat, mishandling, or the incidence of incorrect circuit conditions. As far as the service bench is concerned, probably the best way to check a transistor is by substitution, but in view of the foregoing remarks, a few precautionary checks should be made before resorting to the substitution method of fault clearing. Having isolated the fault to a particular stage, it would be wise at least to check applied potentials before making a substitution. It will be seen then that whereas it is common in servicing sets using thermionic valves to pull the valves and check them early in the procedure, and then later check the circuit if necessary, the reverse is the case with transistorized equipment. In a transistor radio, every effort is made to check the circuit before suspecting or replacing transistors.

Dynamic testing procedures are familiar to servicemen, who have the choice of the signal tracing or the signal injection methods. In the following remarks it will be assumed that the latter method is used, as being perhaps the more popular of the two, and translation into terms of signal tracing should present no difficulty. The basic procedures are no different from those used in thermionic valve radios.

Reference to Fig 2 will show that certain test points have been indicated on the diagram, labelled alphabetically. These test points on this typical receiver are suggested as examples of check points which may be selected on receivers for the purpose of carrying out dynamic tests. Assuming that the set is completely non-operative, a good place to start is between the second detector and the first audio stage, shown at A. If an audio signal injected at this point produces an output, then the fault must lie in the preceding stages. Thus by one simple test, half the set has been eliminated in the search for the fault. Additional check points on the audio section of the receiver would be B and C, assuming that signal at A produces no output. Points B and C then attempt to eliminate the audio stages one by one.

If signal output is heard with an injected audio signal at A, then steps must be taken to trace the faulty stage in the high frequency sections of the receiver. Injecting the intermediate frequency (455 Kc) modulated by an audio tone at D halves the remaining stages to be checked. If no output results, then test with the same frequency at point E. If output is obtained from D, then the fault must be in the converter stage. Checks may then be made at F using the intermediate frequency and at G using any frequency within the

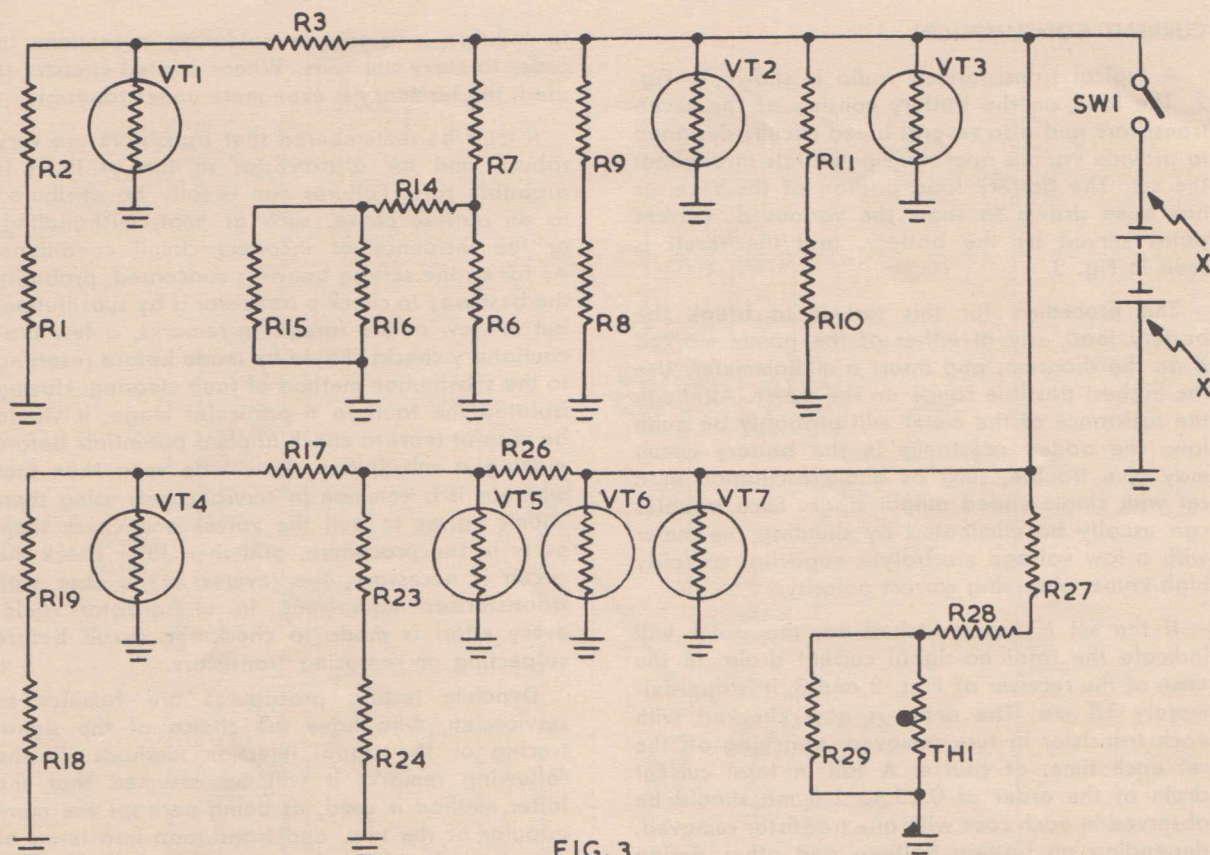

FIG. 3

range of the receiver; the receiver will, of course, have to be tuned to the same frequency. Failure of the local oscillator signal at the converter stage may be checked by tuning the receiver to a known active station and then injecting the calculated local oscillator frequency through a very small capacitor at point H. Slight adjustment of the signal generator may be necessary to secure the correct frequency, and the signal should of course, be unmodulated.

Whilst the foregoing remarks indicate one approach to the problem, any systematic method will produce the required results in fault location. One point to watch is that the input signals at the various test points are at a level which might reasonably be expected there. Too large a signal will lead to misleading results, either in masking low sensitivity or by direct capacitive coupling "jumping" a faulty stage. Too low a signal will, of course, tend to mark a stage as faulty in error. As a guide it may be assumed that levels are generally 20 to 30 db below those in a thermionic valve receiver with similar layout and number of stages, when measured on an input electrode.

It may be as well to stress again here the importance of avoiding a dc path between the generator output terminals. Such a dc path would alter the transistor bias conditions. This position

can be avoided by the insertion of a suitable capacitance in one of the generator leads.

### AUTOMATIC GAIN CONTROL

The automatic gain control characteristic can yield valuable information on set performance in transistorized radios as with other types of set. The purpose of the function is the same, to keep the carrier level at the second detector constant regardless of signal input level, but the manner in which the function operates may be different.

Where p-n-p transistors are used in the controlled stages, the agc voltage is positive. In a thermionic valve the positive input signal is superimposed on a negative bias which holds the valve in the correct operating condition, and the negative agc voltage increases the bias to reduce gain. In the case of the p-n-p transistor, the signal input electrode (base in the common emitter circuit) is negatively biased (emitter with respect to base). A stronger input signal produces a higher positive agc voltage, which drives the base of the controlled transistor less negative to reduce the stage gain.

Where n-p-n transistors are used, the polarities of the respective voltages are reversed, and so is the polarity of the agc voltage, which now be-



comes negative. A stronger input signal produces a higher negative control voltage, which drives the base of the controlled transistor less positive to reduce gain.

Provided this is remembered, the automatic gain control characteristic may be used in the conventional manner in checking sets. Checking for the presence of a control voltage when tuning through a known strong active station is a ready means of testing whether the stages up to and including the second detector are operative.

### CONCLUSION

The servicing of transistorized radios raises no problems new to the serviceman, but a slight reorientation of outlook and adaption of well tried

methods is required. Perhaps the small size of some of the "vest-pocket" type sets will give more trouble than the circuit and components. The use of smaller tools and soldering irons, and the use of a few precautions as outlined in this article, will make the repair of these sets no more difficult than any other type. In fact, the small size and weight of these units has already made them a popular job with many servicemen who have refused to be daunted by new ideas.

### ACKNOWLEDGEMENT

The author wishes to acknowledge the kindness of various A.W.A. and A.W.V. engineers, who read and criticised this article.

## DEFINITIONS

**Class A Amplifier.** An amplifier in which the bias of the input electrode and the alternating input signal are such that output current flows at all times.

**Collector Transition Capacitance.** The capacitance across the collector-to-base transition region. (A transition region is a region between two homogeneous semiconductor regions, in which the impurity concentration changes.—54 IRE 7.S2).

**Current Transfer Ratio.** The change of output current with ac output circuit shorted divided by the change in input current. The current components are understood to be small enough so that linear relations hold between them.

**Unilateralization.** Unilateralization is a special case of neutralization in that the feedback parameters are completely balanced out. In the case of transistors, these feedback parameters include a resistive component in addition to a capacitive component. Unilateralization changes a bilateral network into a unilateral network.

**Alpha-Cutoff Frequency.** Frequency at which the forward current transfer ratio drops to 0.707 times its value at 1 Kc.

**Small-Signal Current Transfer Ratio.** The change of output current with ac output circuit shorted divided by the change in input current. The currents are understood to be small enough so that linear relations hold between them.

**Small-Signal Input Resistance.** Change in input voltage with the ac output circuit shorted, divided by the change in input current.

**Large-Signal DC Input Resistance.** The dc input voltage divided by the dc input current.

## REFERENCES

### Research and Development

"Transistors 1", RCA Laboratories, Princeton, 1956.

### General

"Transistor Electronics", A. W. Lo, R. O. Endres, J. Zawels, F. D. Waldhauer and C. Cheng, Prentice-Hall Inc., 1955.

"Handbook of Semiconductor Electronics", McGraw-Hill Co. Inc., New York, 1956.

"Design, Construction and High Frequency Performance of Drift Transistors", A. L. Kestenbaum and N. H. Ditrack, RCA Review, Vol. 18, No. 1, March, 1957.

See also "Electrons and Holes in Semiconductors" under "T Parameters" below.

### Unilateralization

"Neutralization and Unilateralization", C. C. Cheng, I.R.E. Transactions, Circuit Theory, June, 1955.

### H Parameters

"Transistor Audio Amplifiers", R. F. Shea, John Wiley and Sons Inc., New York, 1955.

### $\pi$ -Parameters

"Study of p-n-p Alloy Junction Transistors from DC Through Medium Frequencies", L. J. Giacoletto, RCA Review, Vol. 15, No. 4, December, 1954.

"Terminology and Equations for Linear Active Four-Terminal Networks Including Transistors", L. J. Giacoletto, RCA Review, Vol. 14, No. 1, March, 1953.

### T PARAMETERS

"Electrons and Holes in Semiconductors", W. A. Shockley, D. Van Nostrand Co. Inc., New York, 1950.

### Manufacture

"Semiconductors and the Transistor", E. W. Herold, Journal of the Franklin Institute, Vol. 259, No. 12, February, 1955.

# TRANSISTOR RADIO SERVICE TECHNIQUES

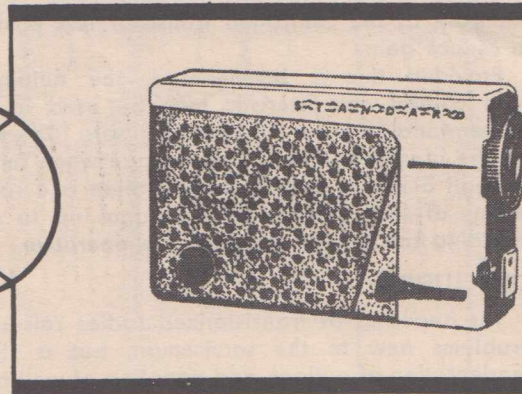
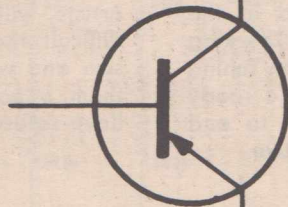

## INTRODUCTION

This article is intended to help servicemen understand transistor radio operation and, by giving a detailed step-by-step service procedure, enable them to satisfy their customers with a minimum of work.

The material has been arranged under headings such as "dead", "weak", etc., corresponding to the customer's usual description when requesting service.

The many "service hints" listed in this publication should not be regarded as indicative of the amount of trouble to be expected. Many of the hints given are similar to everyday "run-of-the-mill" troubles found in thermionic valve radios and would not be mentioned except for the fact that transistor radios are a new experience for many servicemen.

By using an organized test procedure, transistor radio servicing can be made easy for the serviceman and satisfying to the customer. Throughout article, common-emitter type circuits are assumed, as these are the type that will be met.

## TEST METHODS

The procedure to be used in servicing transistor radios is much the same as used with thermionic valve radios. They both employ the superheterodyne circuit, they both pick up a minute signal voltage on an antenna, amplify it and apply it to a loudspeaker.

The test procedure differs only because of the low impedances and the low voltages which are found in transistor radios.

**TEST THE BATTERY FIRST.** Do not perform any service work when operating the set using a weak battery. Do not accept any performance deficiency as being due to a weak battery unless it has been proven by comparison when using a strong battery.

### Performance Indication by Listening

This is the quickest method of localising faults and should be used preliminary to any performance measurements.

## Signal Tracing

Signal tracing is a method of servicing that is applicable to any communication circuit. Either signal tracing or the similar method of signal injection is well adapted to the servicing of transistor radios.

Signal level indication can be had by listening to the sound at the speaker, visual observation on an oscilloscope or, in some cases, measurement with an ac type of VTVM.

## Voltage Measurement

Measurement of dc terminal voltages is just as applicable to the servicing of transistor radios as to the servicing of thermionic valve radios. The most important difference is in the magnitude of the voltages to be measured. The usual maximum terminal voltage which will be encountered in transistor radios is 9 volts. Bias (Base-Emitter) voltages are in the order of 0.05 to 0.2 of a volt.

## Resistance Measurement

Although servicing by resistance measurement is one of the most common testing methods used with thermionic valve radios, this method has severe limitations when applied to the testing of circuits which contain transistors. Transistors will conduct an electrical current when the terminal voltage is supplied from an ohmmeter just as readily as when the voltage is supplied from the radio battery. Because of this transistor conductivity, misleading indications will be obtained and the transistors themselves can be permanently damaged by using resistance measurement.

If resistance measurements are to be made in a transistor radio, the transistors should be removed from the circuit to be tested. If the transistors are soldered in on a printed circuit board, it will be best to disconnect one terminal of the component to be tested.

## Current Measurement

Individual current measurements are seldom made in the servicing of radios because of the difficulty in making such measurements. With battery operated radios, an overall current

measurement is easily made and should be made to assist in diagnosing trouble.

**Test Equipment Required**

Refer to "Circuit Conditions and their Effect on Service Procedure" below.

**SERVICE REQUIREMENTS**

The customer's complaint must be met. It is, therefore, highly desirable to get information from the customer before doing any work on the radio. This is not always possible but an effort should be made to obtain the information.

The radio must be given a complete air test after service work is completed. This should be a listening test with the radio completely assembled.

Regardless of what the stated complaint may be, the following overall conditions should be checked:

- (a) Condition of the battery (voltage with the set turned on).
- (b) Overall current drain with no signal input (see table and manufacturer's data).

Total Battery Current (approx.)

Model *	No Signal	15 mw. out	50 mw. out.
"A" .....	8.6 ma	21 ma	33 ma
"B" .....	6.0	14	—
"C" .....	9.2	—	29
"D" .....	16	16	—
"E" .....	7.8	13	—
"F" .....	8.0	—	28

- (c) Soldered connections. Turn radio on with maximum volume. While listening to the loudspeaker, gently wiggle all visible components with an insulated tool such as alignment tool.
- (d) Sensitivity as determined by a listening test.
- (e) Distortion as determined by a listening test.

**CIRCUIT CONDITIONS AND THEIR EFFECT ON SERVICE PROCEDURE**

**Circuit Impedances**

In thermionic valve radios, both the input (grid) and output (plate) circuits are high impedance. A common practice to determine whether or not a circuit is "alive", is to touch a finger to various points and listen for possible effects on sound emanating from the speaker.

In transistor radios, the input (base) circuit has very low impedance. The output (collector) circuit has medium impedance. The "finger test" method described above will provide no indication in a transistor radio. Figure 1 is an illustrated comparison of the circuit impedances.

\* Figures are given for six typical transistorized portables.

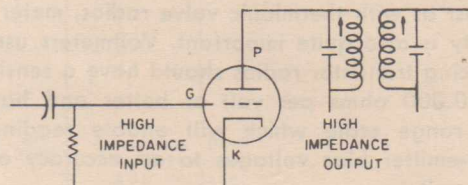
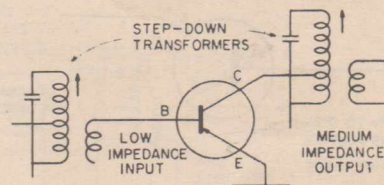

Figure 1 — Comparison of Impedances in Transistor Radios vs. Thermionic Valve Radios.

Since the circuits in a transistor radio are not high impedance (except oscillator and antenna tank circuits), it is not necessary to use low-capacity probes in conjunction with oscilloscopes.

Impedance matching in transistor radios is more critical than in thermionic radios. For this reason, only exact replacement oscillator coils, antennas, if transformers, volume controls, audio transformers and speakers should be used in servicing transistor radios.

Transformers (audio and if) used in transistor radios generally have a step-down ratio and when signal tracing, a very pronounced signal voltage loss will be encountered between primary and secondary. Because of the extremely low signal voltages present at the base input of transistors, a high-gain oscilloscope is required for gain measurements.

**DC Voltages at Transistor Terminals**

The maximum terminal voltage normally encountered in portable transistor radios is 9 volts. With p-n-p transistors the collector voltage and the base voltage are both negative in respect to the emitter. With n-p-n transistors both voltages are positive.

Just as with thermionic valves, a small voltage at the input of a transistor is used to control the output current. But this small voltage (base-emitter bias voltage) is in the order of only 0.05 volt to 0.2 volt. The operation of a transistor with 0.05 volt bias where 0.1 volt is specified will result in distortion. Figure 2 illustrates the voltage relationships to be expected at the terminals of transistors.

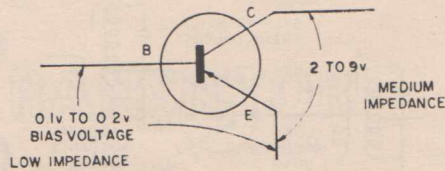

Figure 2 — Normal Operating Voltages (P-N-P Type of Transistor)

Just as with thermionic valve radios, meter sensitivity is also quite important. Voltmeters used in servicing transistor radios should have a sensitivity of 20,000 ohms per volt or better and have a low range scale which will enable reading of base-emitter bias voltages to an accuracy of  $\pm 0.03$  volt.

### Transistor Currents and Bias Voltages

In a thermionic valve, as the negative bias voltage is increased, the plate current decreases. In a transistor, as the bias voltage (base-emitter) is increased, the collector current increases. Collector current cut-off occurs when the bias is reduced to zero. Figure 3 illustrates this current/voltage relationship.

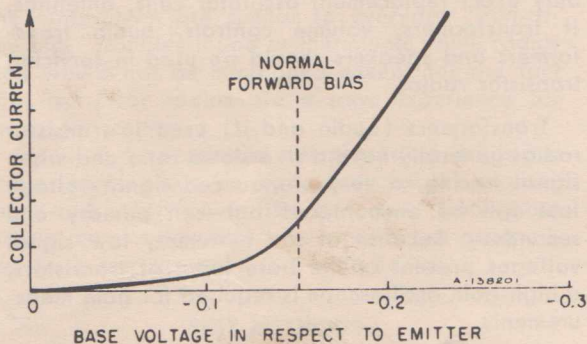

Figure 3 — Bias Voltage vs. Collector Current (P-N-P Type of Transistor)

In transistor radios using push-pull "Class B" output, the battery current varies widely with signal. In one typical model the battery current is 8 ma with no signal and 29 ma with 50 mw output.

A current condition with all transistors but not found in thermionic valve radios is that a small current flows in the signal input circuit (base-emitter). This current, although only a small fraction of the collector current, varies with base-emitter bias in the same manner as collector current. This relationship is illustrated in Figure 4.

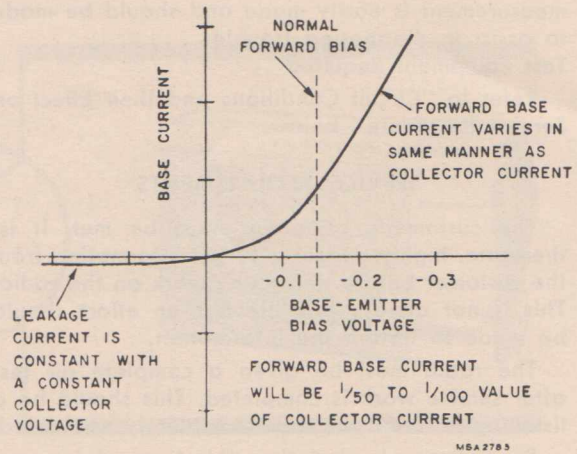

Figure 4 — Base Current vs. Bias Voltage (P-N-P Type of Transistor)

When the base-emitter voltage is reduced to zero, a slight reverse current flows in the base-emitter circuit. This is internal leakage from the collector which is at normal potential.

Total battery current is readily measured on transistor radios. Comparison with normal values published in the service data is of great assistance in troubleshooting.

### AGC System

On some transistor radios an "overload diode" is used to reduce the sensitivity on strong signals. The agc voltage changes the current in the 2nd if transistor and thus increases the dc voltage across the overload diode. This causes the diode to conduct and reduce the gain of the if transformer. Figure 5 is a simplified diagram of the voltage relationships in an "overload diode" circuit. If agc voltage were used to control the gain of transistors themselves, the transistors might be driven to "cut-off" on strong signals — distortion would result.

### Signal Tracing Equipment

Because of the extremely low signal voltages present at the base input of transistors a high-gain oscilloscope is required for gain measurements. Because of frequent distortion problems which have been encountered, an oscilloscope is also very desirable for the purpose of observing waveform. Many types of signal tracer in common use for signal tracing several years back, can also be employed for signal tracing in transistor radios. An ac type of VTVM can be used for signal tracing in the audio circuits of transistor radios.

When using signal tracing in a transistor radio, it should be remembered that all transformers, from the antenna coil to the output transformer, are step-down type and a great reduction in signal voltage can be expected between the collector

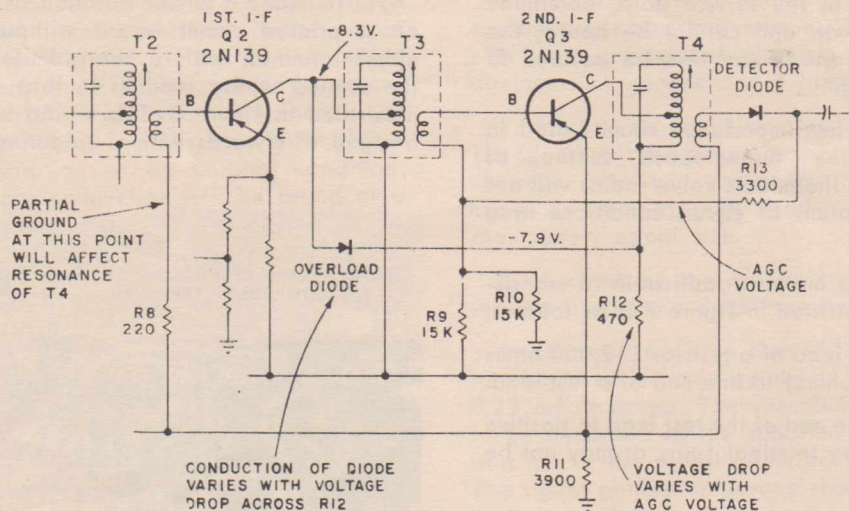

Figure 5 — Overload Diode System of AGC

of one transistor and the base of the following transistor. The ratios to be expected are illustrated in Figure 6.

#### TEST PROCEDURE WHEN SET IS "DEAD"

1. Turn the set on and check battery voltage. Under usual conditions the battery will continue to operate the set until its voltage under normal load has dropped to two-thirds of its rated voltage when new. Try a new battery if there is any doubt.

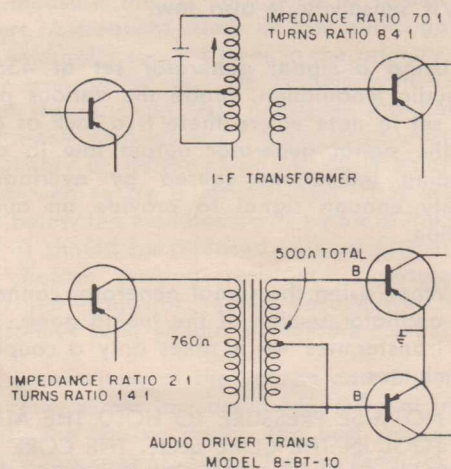

Figure 6 — Transformer Ratios used in Transistor Radios

2. If the battery is satisfactory, hold the set up to your ear and turn the on-off switch "on" and "off". Clicks should be heard through the speaker. No clicks could mean an open voice coil of the speaker or an open connection at the earphone jack.

3. Determine if the oscillator circuit is operative. The usual method is to remove the chassis from the case and check at the converter transistor using an oscilloscope. However, oscillator operation can be determined by bringing the transistor radio close to any other AM radio which is operating and tuned to a broadcast station between 1100 Kc and 1600 Kc. Turn the transistor radio on and turn its tuning dial from one end to the other end. If the oscillator circuit in the transistor radio is working, a heterodyne squeal will be heard on the AM radio when the transistor radio is tuned to 455 Kc below the broadcast station frequency. (Example: Broadcast station at 1400 Kc and transistor radio at 945 Kc. This condition is true even if the audio section of the transistor radio is dead.)

4. If the oscillator is working and a click was heard in the speaker, (a) connect the ground lead of a signal generator to either battery lead, (b) set the signal generator to 455 Kc (with audio modulation), (c) set the signal generator to give high output, (d) connect a capacitor (.01 to .1) in series with the high-side signal generator lead, (e) turn the transistor radio on and touch the free end of the capacitor to the terminals of each component in the transistor radio to determine where a signal can be heard and where it cannot be heard. By referring to the schematic diagram and the

component layout in the service data, determine where the signal can and cannot be heard; the point of signal stoppage can thus be isolated to one particular stage.

Because of the low-impedance circuits used in transistor radios, the "finger touch" method of checking used with thermionic valve radios will not provide any indication of circuit conditions in a transistor radio.

A "click" testing method applicable to transistor radios and illustrated in Figure 7 is as follows:

- (a) Attach one lead of a resistor (12,000 ohms to 15,000 ohms) to one end of a test lead.
- (b) Connect one end of the test lead to positive (+) battery terminal (may or may not be "ground").
- (c) Touch the free end of the resistor to transistor terminals, starting with the output stage, while listening for "clicks" in the speaker.

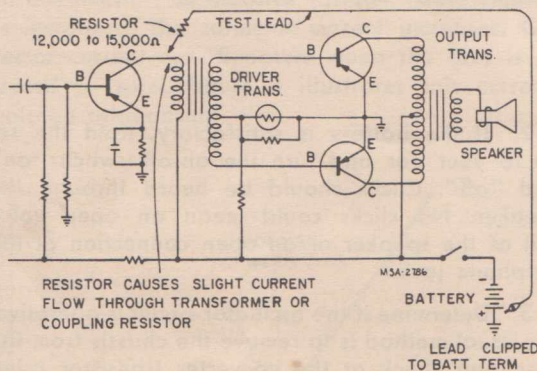

Figure 7 — "Click" Probe for use in Checking Transistor Radios

5. Having determined in what part of the circuit the signal stoppage occurs, use a voltmeter to measure the voltages at the transistor in the suspected stage.

Open resistors, improperly soldered (cold joint or rosin joint) connections and shorted capacitors are the most likely causes of incorrect voltages.

The most important voltage is the base-to-emitter voltage. This will (except for the converter) be 0.1 to 0.2 volts; this voltage on the converter transistor will be approximately 0.05 volts. The polarity will depend upon the transistor type.

6. If satisfactory voltage indications are obtained, the trouble will most likely be (a) an improperly soldered connection at an if transformer or at a capacitor, or (b) an open capacitor. Improperly soldered connections can most easily be located by probing with a plastic alignment tool and even a tooth pick.

7. To make a circuit isolation of a component on a printed circuit board without removal of either terminal, with a sharp knife, cut through the printed wiring leading to that component as illustrated in Figure 8. This wiring break is easily bridged afterwards with a soldering iron.

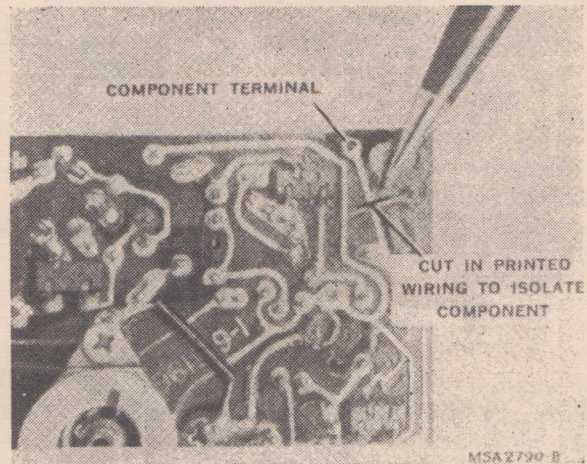

Figure 8 — Component Isolation on Printed Circuit Board

#### TEST PROCEDURE WHEN SET IS "WEAK"

USE A NEW BATTERY AND GIVE THE SET AN AIR TEST TO DETERMINE WHETHER THE FAULT IS IN THE AUDIO SECTION OR IN THE RF/IF SECTION.

If a set has low rf/if sensitivity, it may provide loud volume on strong nearby stations but distant stations will be weak or not heard at all.

If a set has a low audio sensitivity, it will have weak volume on all stations with little change between nearby stations and distant stations unless the rf/if sensitivity is also low.

2. Using a signal generator set at 455 Kc with audio modulation, probe the various points in the set to note where there is a lack of gain. Keep the signal generator output low to avoid misleading indications caused by overloading; use only enough signal to provide an audible indication.

3. When using the signal generator connected to the oscillator section of the tuning gang, peak the if transformers — it takes only a couple of extra minutes.

DO NOT USE PRESSURE TO HOLD THE ALIGNMENT TOOL IN THE CORE SLOT. THE CORE CAN BE FORCED OUT OF POSITION IF EXCESS PRESSURE IS APPLIED. When a core is forced out of position it may be necessary to replace the transformer.

When the resonance peak is reached, there should be a very definite decrease in the output with only one-quarter turn of the core in either direction. A transformer having a broadly resonant peak should be repaired or replaced. See "Test Procedure When Set Has Low RF/IF Gain" below for description of an unusual condition. Sometimes a poor connection will be found at a transformer terminal lug.

4. After localizing the trouble to be in either the audio or rf/if sections, use the procedure outlined in:

- (a) TEST PROCEDURE WHEN SET HAS LOW AUDIO GAIN.
- (b) TEST PROCEDURE WHEN SET HAS LOW RF/IF GAIN.

#### TEST PROCEDURE WHEN SET HAS LOW AUDIO GAIN

1. Use a signal generator having audio modulation to localize defect as described in preceding section "Test Procedure When Set is Weak". Remember that all transformers are step-down.

2. Measure voltages at the audio transistors, paying particular attention to the base-emitter bias voltage. This voltage should be between 0.1 volt and 0.2 volt; the base is negative with respect to the emitter. Low voltage decreases sensitivity and high voltage will cause high current drain. Distortion will also be caused by a low-voltage condition.

3. Leaking by-pass capacitors have sometimes been found to have a partial short-circuit. This lowers all voltages in the rf/if and 1st audio sections and lowers overall sensitivity. A preliminary voltage check at the filter capacitors will show if this condition exists.

4. Measure the dc resistance of audio transformers. A frequent cause of low audio gain has been internally shorted turns in the primary of the driver transformer used in models with Class B output stages. Gain tests by signal injection may not readily disclose this trouble. Measurement of the primary dc resistance of this driver transformer has proven to be a reliable test. If it measures 10% below the manufacturer's figure in the service data, it should be replaced without further question. Before making resistance measurements, either the transistor should be removed or the transformer lead should be disconnected.

5. Loose rivets at the volume control terminals may cause either low audio sensitivity or inability to turn the volume down. The best remedy is to replace the control. Soldering the terminal to the rivet has sometimes been effective; it doesn't hurt to try it if the control would otherwise be scrapped.

6. Poorly soldered connections in the audio section may cause low volume. Wiggling components with a insulated alignment tool will often disclose such connections if they should exist.

7. Electrolytic capacitors are used as coupling (or blocking) capacitors in the audio circuit. Low capacity units will cause low audio sensitivity. Check by shunting with another capacitor of approximately equal size.

8. A check of the overall audio gain against the manufacturer's data may be made.

In all cases, the high side of the signal generator should be isolated by use of a series capacitor 0.25 mf or larger. The specified input voltage is to be measured at the specified connection point and not at the signal generator output terminals. The signal generator ground should be connected to the circuit ground of the transistor radio.

#### TEST PROCEDURE WHEN SET HAS LOW RF/IF GAIN

1. Check if alignment — this normally should be done when making preliminary tests with a signal generator. Refer to preceding sections "Test Procedure When Set is Weak". The following are if alignment suggestions.

- (a) Where there is only one core to each if transformer, in some cases two peaks may be reached, one peak being higher than the other. Refer to the service data.
- (b) Where a transistor stage shows low gain, shunt each by-pass capacitor in that stage with another capacitor to detect open capacitors. An open by-pass capacitor in the circuit of that transformer could give an unsatisfactory peaking condition.
- (c) If a transformer can not be peaked at if, the trouble can be due to a defective transformer or to a defective transistor (if or converter) — try replacing transistor and try resoldering transformer terminal connections before replacing transformer.

2. If if alignment does not restore if sensitivity, measure transistor terminal voltages. Pay particular attention to the base-emitter voltage of the if transistors. This voltage should be approximately 0.15 volts; low voltage (0.1 volt) will lower sensitivity and high voltage (0.2 volt) will cause high current drain.

Although voltages may vary widely without greatly affecting stage gain, the voltages should all have the same proportion of variation. The bias voltages are the most difficult to measure but must not be neglected. If a large voltage discrepancy is found it will be necessary to remove transistors before making resistance measurements in localizing the trouble.

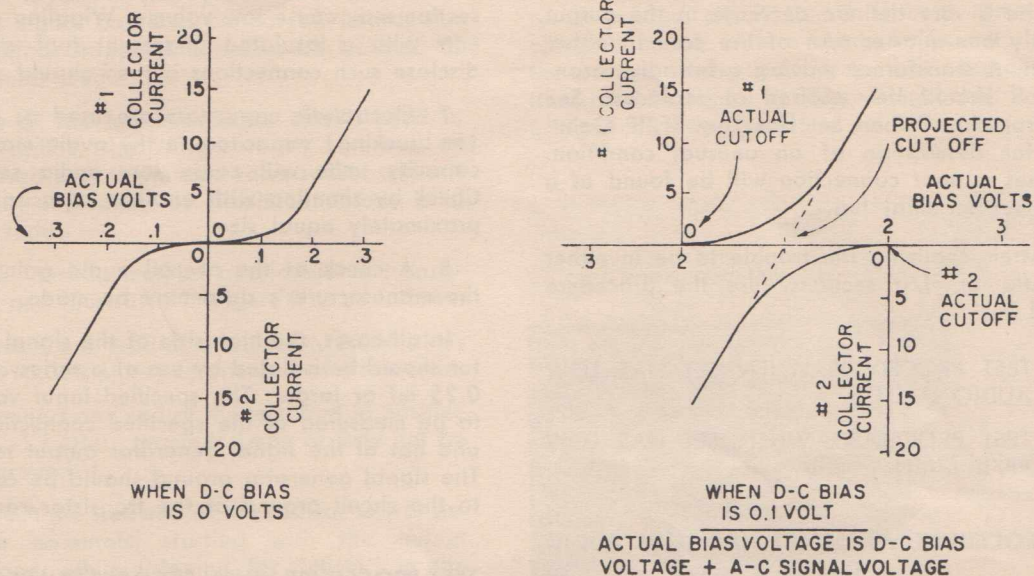

Figure 9 — Crossover Distortion in Class B Circuit due to Improper Bias Voltage.

3. On radios using an "overload diode", the dc voltage across the diode determines the point at which it starts to conduct and thereby reduce the gain. Incorrect voltages may cause the diode to conduct with low signal input.

4. Leaking by-pass capacitors have sometimes been found to have a partial short-circuit. This lowers all voltages in the rf/lf and 1st audio sections and lowers overall sensitivity. A preliminary voltage check at the filter capacitors will show if this condition exists.

5. If the lf transformers all peak properly and the set still shows low rf/lf sensitivity, check the oscillator alignment. This may be done by setting the tuning dial close to 600 Kc and away from any station and adjusting the core of the oscillator coil for maximum noise. This is very effective when near a fluorescent light. If adjustment of the oscillator coil gives much improvement, proceed with a complete realignment following the procedure outlined in the service data.

6. Other possibilities of low rf/lf sensitivity are as follows:

- (a) Incorrect transistor — if type 2N139 is used in place of specified type 2N140, conversion gain will be down and oscillator section may fail to operate when battery voltage is down slightly.
- (b) Detector diode reversed — output is down slightly. Check by noting polarity of agc voltage at the diode source. On models which use n-p-n transistors in the lf stages, the agc line voltage at the diode will become more negative (or less positive) in respect to circuit ground with

signal increase. On all other models, using p-n-p transistors, the polarity will be reversed.

- (c) Antenna rod winding shorted at end connection — disconnect and measure resistance.

#### TEST PROCEDURE WHEN SET IS "DISTORTED"

Distortion as described below is generally regarded as amplitude distortion in which sounds are mushy.

1. For accurate determination of the existence and the origin of distortion in any radio receiver, there is no substitute for the use of an oscilloscope and signal generator. After finding out where the distortion originates, a voltage check (especially bias voltage) will assist in pin-pointing the trouble.

2. Amplitude distortion is most often caused by improper terminal voltages on the audio transistors. The first thing is to check the terminal voltages (including the battery itself) with the set turned on. Try a new battery if voltages are low.

3. The collector-emitter voltages are comparatively easy to read; see service data for specified values.

4. The base-emitter voltage on "Class B" push-pull transistors should be 0.08 volts to 0.12 volts. Low voltage will cause a form of amplitude distortion known as "Crossover distortion" and is most noticeable on low volume. This condition is illustrated in Figure 9. If the bias voltage cannot



be accurately measured, the collector currents can be measured with a milliammeter in series with a transformer lead. Proper bias results in a total no-signal current of between 1.5 and 2ma in the two output transistors.

5. For minimum distortion, matched output transistors should be used in push-pull output stages. Matching may be checked by measuring audio output voltage with an oscilloscope across each half of the output transformer. Equal voltage output should be had from matched transistors if a constant audio signal is injected at the volume control.

6. Where improper voltages are found, they are most often the result of resistors having changed value. The natural procedure, after having isolated the source of distortion to two or three resistors, is to measure the suspected parts and replace the defective one. Accurate measurement of resistance in a transistor circuit requires that **THE TRANSISTOR IN THAT CIRCUIT MUST BE REMOVED BEFORE USING THE OHMMETER.** Transistors will conduct current from the ohmmeter even if the power supply battery is removed. An alternative to removal of the transistor, is to disconnect one end of the suspected resistor and apply the ohmmeter in such a way that a transistor will not be in the circuit to be measured.

To isolate a component on a printed circuit board without removal of either terminal, cut through the printed wiring leading to that component with a sharp knife as illustrated in Figure 8. This wiring break is easily bridged afterward with a soldering iron.

7. There is a possibility of distortion in the diode detector circuit if a slight forward dc bias is not applied to the diode. With no signal input, there should be approximately 0.1 volt across the detector diode as measured with a VTVM; the voltage will increase directly with signal increase (see Item 8 which follows).

8. An overload diode is used in most of these transistor radios to reduce the gain of an if transformer with signal increase. If this diode is open or connected in reverse, the if transistors will be overloaded on strong signals. This diode will normally limit the signal applied to the detector diode, holding it relatively constant with a wide range of signal input level. Incorrect terminal voltages at the diode terminals will change the point at which the overload diode starts to conduct. The 2nd if transistor may thus become overloaded before the diode starts its limiting action.

Use a signal generator and apply if to the oscillator section of the gang condenser and observe the waveform with an oscilloscope at the detector diode using different levels of signal input. The waveform should be an undistorted

sine wave at all input levels. The comparison between an undistorted and a distorted sine wave is illustrated in Figure 10.

#### TEST PROCEDURE WHEN SET HAS REGENERATIVE "SQUEAL"

Regenerative squeal or oscillation in most cases is caused by a high resistance connection in the "common ground" circuit. All "ground" connections must be of lower resistance than similar connections in thermionic valve radios because of the low impedances of transistor circuits.

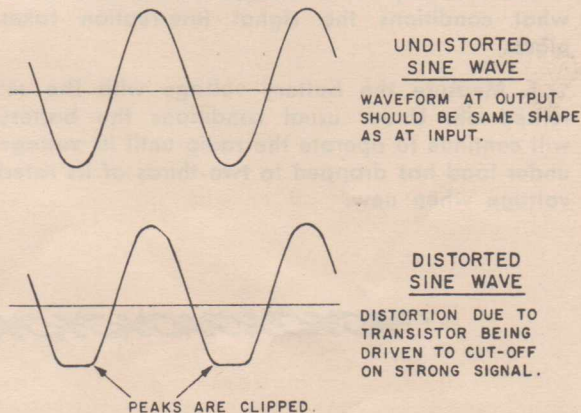

Figure 10 — Undistorted Sine Wave vs. Distorted Sine Wave.

As described above, "ground" connections mean not only visible metal-to-metal connections but also the internal ac impedance of capacitors.

The first step in correcting a regenerative squeal condition is to eliminate all possibility of high resistance metal-to-metal visible connections.

If the first step does not eliminate the regenerative condition, it will be necessary to check the items described in the following text.

1. High internal battery resistance. A new battery corrects the trouble.
2. High resistance riveted battery connections.
3. High resistance connections at chassis mountings. This condition is evidenced by a change in the frequency and intensity of the squeal when mounting screws are first loosened and then tightened.
4. The mounting lugs of if transformers are sometimes used for ground inter-connections. Loose lugs can result in intermittent regeneration. This condition may be detected by slightly pressing on the sides and top of the if transformer cans. Solder a jumper wire between the two mounting lugs of each can.
5. Low value filter capacitors.
6. High resistance connection at electrolytic capacitor terminals. This has the same effect as low capacity.

7. An if transistor having exceptionally high gain may cause regeneration on weak signals. This condition can sometimes be corrected by interchanging if transistors. Realignment is advisable after any change of transistors in the if circuit.

8. If an incorrect type transistor is used, regeneration may occur. Check for use of correct type of transistor.

#### TEST PROCEDURE WHEN SET IS "INTERMITTENT"

The first step is to localize where and under what conditions the signal interruption takes place.

1. Measure the battery voltage with the set turned on. Under usual conditions the battery will continue to operate the radio until its voltage under load has dropped to two-thirds of its rated voltage when new.

2. Use an insulated alignment tool or similar object to probe and slightly wiggle every component to search for poorly soldered connections. Resolder any suspected connection. Slightly flex the circuit board, speaker and tuning condenser to search for intermittent open circuits and/or short circuits due to excess solder.

3. To locate a break in printed wiring, use the points of a pair of long-nose pliers or other tool to bridge a suspected break location. Go over suspected wiring with soldering iron and solder.

4. Look for excess solder that may make contact only when set is placed in its case.

5. If the preceding physical examination does not enable the trouble to be localized, it will be necessary to use signal tracing or signal injection to localize the fault.

(With acknowledgements to RCA)



## DRIFT TRANSISTORS

(Continued from page 8)

transit time of the carriers in a conventional transistor. This results in greatly increased high frequency performance.

#### Drift Transistors Provide Superior Performance

The high impurity density in the base near the emitter results in a low base resistance, while the low impurity density near the collector contributes to low collector capacitance and results in a high collector breakdown voltage. The extremely low value of collector capacitance makes neutralization unnecessary in most applications and permits the design of simple and economical circuits.

The combination of low base resistance, high collector breakdown voltage, low collector capacitance, and short transit time, makes possible the design of high power gain, high-frequency circuits with excellent operating stability and good automatic gain control capabilities over a wide range of input signal levels.

#### Shielding Minimizes Interlead Capacitance

Drift transistors generally have four flexible leads and are hermetically sealed in metal cases. The fourth lead is connected to the case internally to minimize interlead capacitance and reduce coupling to adjacent circuit components. These important design features contribute to the useful-

ness of drift transistors in high-frequency circuits, particularly in those military and commercial applications where low feedback capacitance is an important design consideration.

#### High Frequency Applications

The use of drift transistors in high frequency applications offers the following advantages:

- Low base resistance.
- High output resistance for increased gain.
- Low feedback capacitance.
- High alpha cutoff frequency.
- Controlled input and output characteristics.
- Controlled power gain characteristics to insure unit-to-unit interchangeability.
- Rugged mechanical construction.
- Excellent stability.
- Exceptional uniformity of characteristics.

#### Design Benefits

Design benefits obtained by the use of drift transistors include high input-circuit efficiency, excellent high-frequency operating stability, good signal-to-noise ratio, and good automatic-gain-control capabilities over a wide range of input-signal levels.





962