

Mullard

Outlook

AUSTRALIAN EDITION

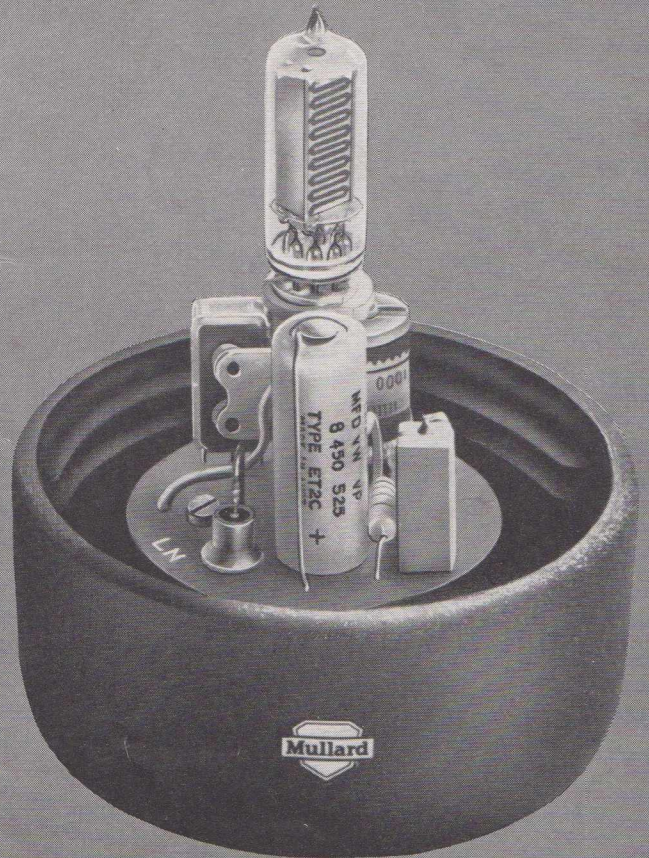

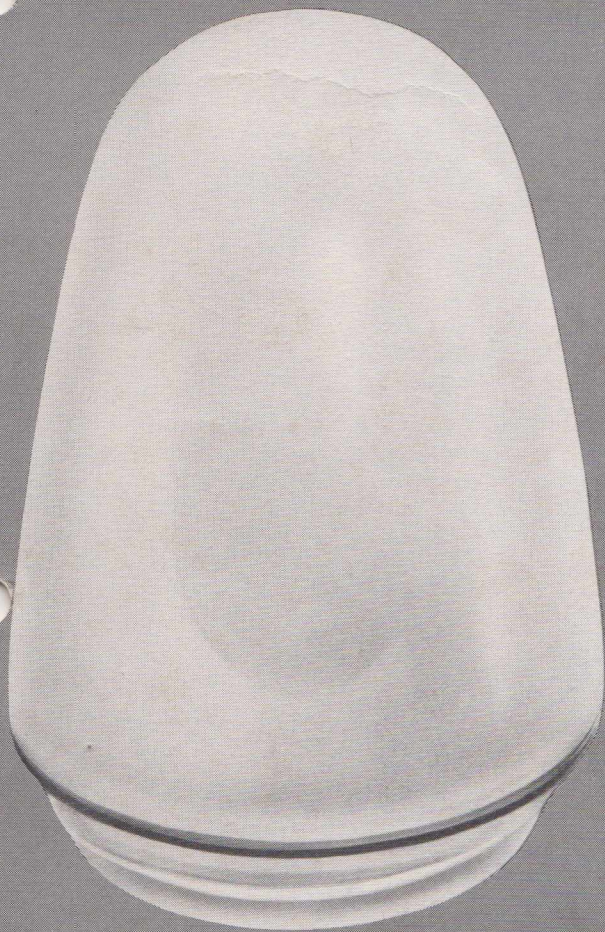

MULLARD-AUSTRALIA PTY. LTD.



VOL. 8 — No. 4

JULY-AUGUST, 1965

Editorial Office:
35-43 Clarence Street, Sydney.
Telephone: 29 2006

Editor:
JOERN BORK

All rights reserved by Mullard-Australia Pty. Ltd., Sydney. Information given in this publication does not imply a licence under any patent. Original articles or illustrations reproduced in whole or in part must be accompanied by full acknowledgement: Mullard Outlook, Australian Edition.

Outlook Reference Number
Mitchell Library, Sydney, N.S.W.
Q 621.3805

1

TABLE OF CONTENTS

Viewpoint with Mullard	55
Street Lighting Controller Using a Photoconductive Cell	56
Five-Watt Transistor High-Quality Amplifier	58
Erni Relay Types 20 KW and 20 KWW	60
Microwave Cooking — Part II	61
EF86 Still Further Improved	62
Pioneer Honoured	62
Ferroxcube for Transformers	63
Multi-Cam Process Programming Switch	64
New Colour Television Picture Tube — A63-11X	64
Science in the Development of Australia Exhibition	64

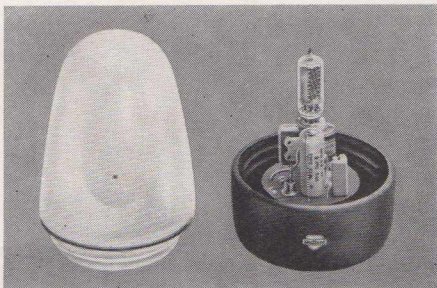

Street lighting controller, subject of an article in this issue, is housed in a standard outside light fitting.

MULLARD-AUSTRALIA PTY. LTD.
35-43 CLARENCE STREET, SYDNEY
Phone: 29 2006
123-129 VICTORIA PDE., COLLINGWOOD, N.5
VICTORIA
Phone: 41 6644
Associated with
MULLARD LTD., LONDON

THE LAMPLIGHTER

*My tea is nearly ready
and the sun has left the sky;
It's time to take the window
to see Leerie going by;
For every night at tea-time
and before you take your seat,
With lantern and with ladder
he comes posting up the street.*

*Now Tom would be a driver
and Maria go to sea,
And my papa's a banker
and as rich as he can be;
But I, when I am stronger
and can choose what I'm to do,
O Leerie, I'll go round at night
and light the lamps with you!*

*For we are very lucky,
with a lamp before the door,
And Leerie stops to light it
as he lights so many more;
And O! before you hurry by
with ladder and with light,
O Leerie, see a little child
and nod to him to-night!*

Robert Louis Stevenson

It was intended to use only one verse of The Lamplighter, but we were touched by the sheer beauty, delicacy and simplicity of a little child's thoughts — it therefore had to be the lot or nothing.

The lot it is and Leerie too our hero in some remote way — a Santa Claus who every day and at darkness is required to be in so many places at the same time. In streets, shop windows, stores and factories, homes and passages he turns on and off the lights for us. Our Leerie is shown in this journal and for his lantern and his ladder — a Mullard cadmium sulphide cell and should sweet sentiment evoke the engineers who use these cells, may they each day when darkness falls, pay Leerie pensive tribute and a mystic nod.

M.A.B.

MULLARD DISTRIBUTORS

<p>New South Wales Martin de Launay Pty. Ltd. Cnr. Druitt & Clarence Sts., Sydney. Phone: 29 5834 Cnr. King & Darby Streets, Newcastle. Phone: 2 4741 270 Keira St., Wollongong. Phone: 2 6020 21 Bayliss Street, Wagga. Phone: 4644</p>	<p>Queensland C. A. Pearce & Co. Pty. Ltd. 33 Bowen Street, Brisbane. Phone: 2 3201</p>	<p>Tasmania Medhursts Wholesale Ltd. 163 Collins Street, Hobart. Phone: 2 2911 136 Wellington Street, Launceston. Phone: 2 2091 106 Wilson Street, Burnie. Phone: 1919</p>
<p>Victoria Carnegie (Australia) Pty. Ltd. Vere Street, Richmond. Phone: 42 2781</p>	<p>South Australia Telcon Australia Pty. Ltd. 266-270 Sturt Street, Adelaide. Phone: 51 6341</p>	<p>Special Representative for A.C.T. George Brown & Co. Pty. Ltd. 22-28 Whyalla Street, Fyshwick. Phone: 9 1414</p>

and all leading wholesalers throughout the Commonwealth

V I E W P O I N T W I T H M U L L A R D

NEW MULLARD DISTRIBUTOR

Mullard are pleased to announce the appointment of Telcon Australia Pty. Ltd., as their sole distributor for South Australia.

The appointment became effective on 1st July, 1965 and to mark the occasion, Mullard and Telcon were joint hosts at a function in Adelaide on the evening of 30th June, 1965 at which 230 guests representing industry, Government Departments, public utilities and educational establishments were present.

The formal proceedings were opened by Telcon South Australia Manager, Mr. J. Roach, who welcomed the guests and introduced Mr. F. W. M. Lewis, Telcon Managing Director. Mr. Lewis pointed out that the Mullard range of products was complementary to those of Telcon and added that he looked forward to a mutually beneficial association between the two Companies in South Australia.

Mullard-Australia General Manager, Mr. M. A. Brown commented on the interest shown today in industrial electronics and remarked that Telcon were already well-established in this field. Mr. Brown then made a presentation to Woollard & Crabbe Managing Director, Mr. T. Crabbe and Sales Manager, Mr. L. Scott, in recognition of their assistance as the former Mullard agents.

Mr. L. A. Wade, Mullard-Australia Sales Manager, outlined the activities of the Applications Engineering Laboratory and the technical service available from Mullard.

The meeting was then addressed by Mr. H. S. Watson, Chief Engineer Mullard-Australia, who covered some aspects of industrial control and automation.

A comprehensive range of electronic components and equipment was on display. In addition to the latest developments in valves, electron tubes, semiconductors and building elements, Erwin Sick photoelectric equipment, for which Mullard are sole distributors in Australia and New Zealand, was demonstrated for the first time.

Working models of a Norbit fire alarm system and a Microelectric sequential timer were also shown; and a prototype microwave cooking range, using a 1kW CW magnetron, created much interest amongst the visitors.

The Mullard Resident Representative for South Australia Mr. B. J. Brice, is now located at the Telcon office, 266-270 Sturt Street, Adelaide and is assisted by Mr. Lew Ward.

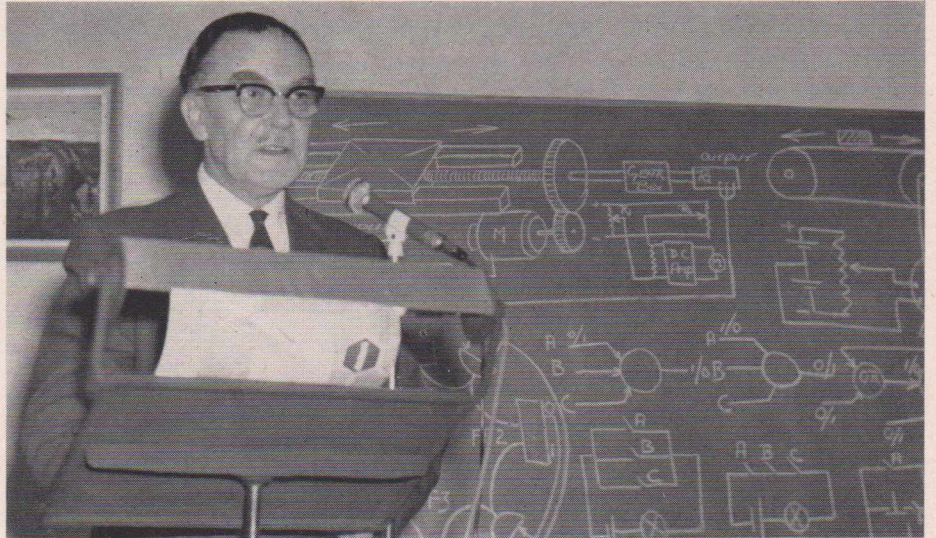

ABOVE:
Mr. F. W. M. Lewis, Telcon Managing Director, addressing the gathering at the function.



AT RIGHT:
Mr. J. Roach, Telcon South Australia Manager, welcoming the guests to the function marking the appointment of Telcon Australia Pty. Ltd., as sole distributor for Mullard in South Australia.

BELOW:
Mr. M. A. Brown, General Manager Mullard-Australia Pty. Ltd. informing the meeting of our extended interests in industrial electronics.



STREET LIGHTING CONTROLLER USING A PHOTOCONDUCTIVE CELL

This article describes a reliable cadmium sulphide street lighting controller which has several advantages over the more expensive clock control units. Automatic control of artificial lighting is used in a wide variety of situations; for example, factory lighting, the lighting of goods depots and marshalling yards, store window displays and conventional street lighting.

Switching takes place at predetermined light levels rather than at predetermined times, thus allowing for abnormal periods of darkness at dusk, dawn or during the day and for the special needs of streets where the light level is obstructed, such as tree-lined streets. A delay circuit obviates switch-off by lightning flashes and other transient illumination. The unit is independent of power failures and cheaper than synchronous clock and other control units.

General Requirements

In a street lighting controller, the switching level must be related to the required time of lighting the streets, which varies from district to district and state to state.

A light level which may be experienced on a typical evening is depicted in Fig. 1. Generally, street lights are switched on at a level approximately corresponding to 27 lux. As it is difficult to obtain a precise sensitivity level requirement from the graph shown in Fig. 1, the approach has been to design the controller to be as sensitive as possible.

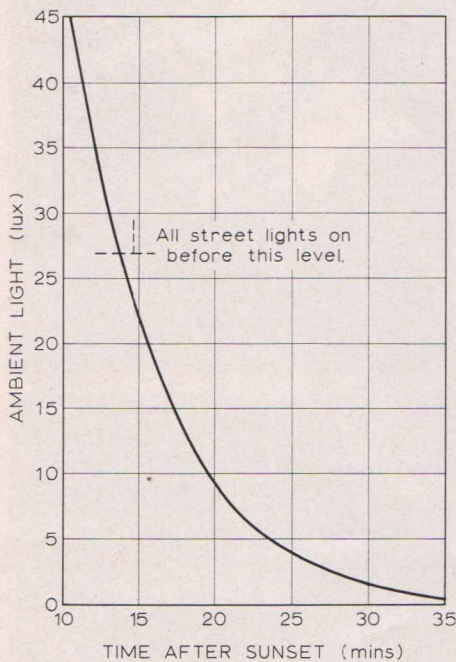

Fig. 1. Typical variation of light level after sunset.

A number of measurements of background light levels indicate that in a well-lit street the light level at night (excluding light from shop windows), is not greater than about 0.5 lux. Therefore, switching at a level of some 3 lux is taken as a target requirement.

The circuit has to incorporate a delay to prevent the street lights being switched off during the night by spurious flashes of light. This is essential where mercury or sodium vapour lamps are used, since 10 to 15 minutes have to elapse while the lamp cools

Initially the current through the ORP93, the relay, and the thermistor is low, and because of this the thermistor retains its high resistance; the resistance of the cadmium sulphide cell drops once it is illuminated and the current is increased.

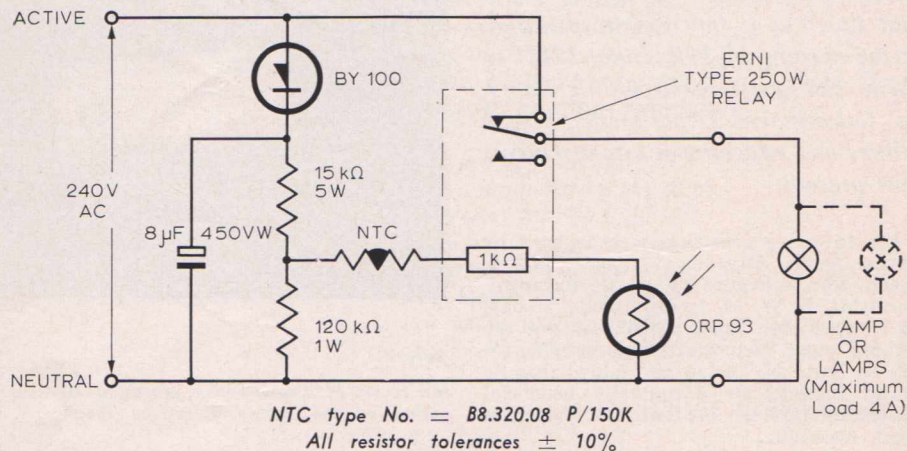

Fig. 2. Circuit diagram of street light controller using ORP93.

down sufficiently to restrike.

To increase the reliability of the controller an Erni relay type 250KW (1kΩ) is used. This relay is equipped with a micro-switch featuring a positive snap action to minimise contact wear and arcing. It may be used under normal conditions to switch up to 4A at 240V AC.

For lighting controls exposed to the weather a suitable housing should be used. Apart from the immunity from ingress of water and insects, the housing should have adequate safeguards against condensation, and protection for the cadmium sulphide cell from direct sunlight. The prototype controller is housed in a standard outside light fitting and must be considered purely as a demonstration unit.

Street lighting controllers should be mounted high up, well clear of shop, vehicle or street lights. The orientation of the photocell should be such that it will face in a southerly direction to avoid high light levels due to direct moonlight.

Circuit Description

The circuit of the unit is shown in Fig. 2. The active part of the circuit consists of a Mullard type ORP93 cadmium sulphide photocell which is connected in series with the relay and load resistor. The load resistor is formed by a Mullard Varite Thermistor, (negative temperature coefficient resistor), which acts as the delay element in the circuit.

When the cell is illuminated at a very low light level, the current through the thermistor, the relay, and the cell is low, hence the dissipation in the thermistor is small and the component has a high resistance.

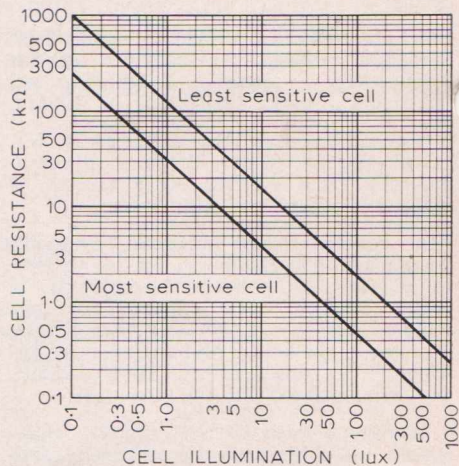

Fig. 3. ORP93: variation of cell resistance with illumination.

If the cadmium sulphide cell is then illuminated at a high light level, the cell resistance falls and the current rises; but the current is limited by the high cold resistance of the thermistor, so that the relay cannot close. The resistance of the ther-

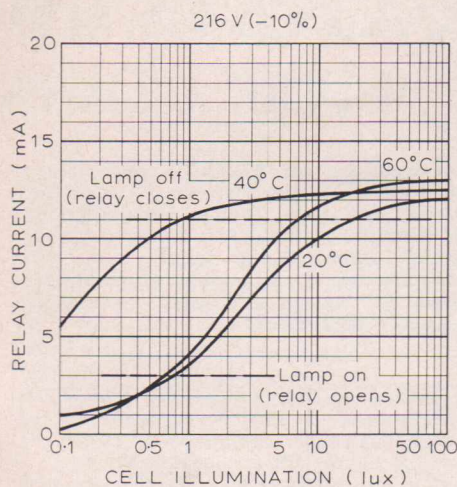

Fig. 4. Operating range (-10% supply voltage).

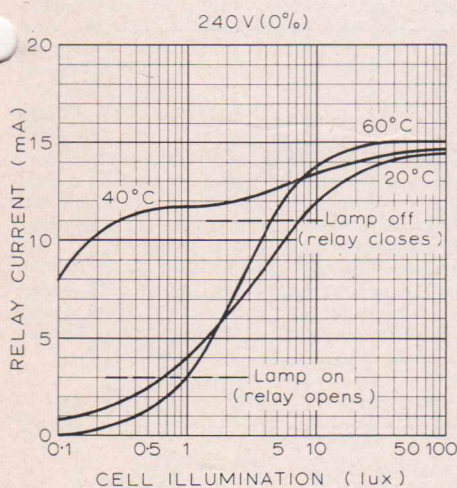

Fig. 5. Operating range (at normal supply voltage).

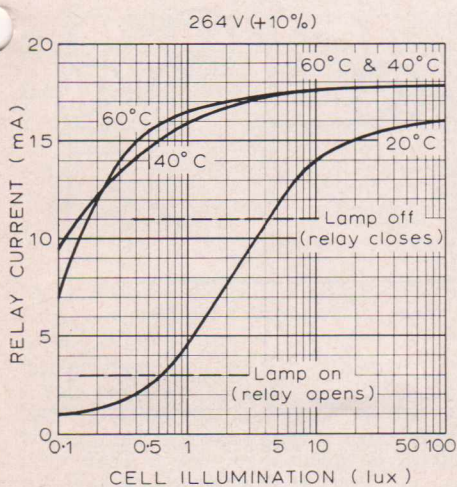

Fig. 6. Operating range (+10% supply voltage).

mistor then falls as the dissipation rises, until after a delay, the relay is energised. This delay is of the order of several seconds, depending on the intensity of the illumination and also on the background light level. Brief illumination, even at a high light level, will not produce sufficient heating of the thermistor to reduce its resistance to a value at which actuation of the relay will take place.

Circuit Design

The ORP93 cadmium sulphide cell was chosen, since it has a maximum power dissipation rating of 1.0W at 25°C, and a maximum supply voltage rating of 275V r.m.s. or 400V DC. The operating conditions in the circuit are within these ratings. The illumination/resistance characteristic of the ORP93 is shown in Fig. 3. A maximum resistance cell was chosen for the design, since the sensitivity of the unit can be decreased by masking off a portion of the active area when the unit is completed.

Using the nominated thermistor, the total series circuit resistance of the relay and cell for day light is 24kΩ with a relay pull-in current of 12mA.

The total circuit resistance of 24kΩ is also sufficient to keep the power dissipation of the cell well within its ratings under all conditions. High rectifier efficiency is achieved by placing the 8μF capacitor from the rectifier to neutral in preference to the junction of R₁ and R₂ in order to keep the charging impedance low. The Mullard silicon diode, BY100 is used as a rectifier. This has a peak inverse rating of 800V (maximum duration = 10ms), and can withstand a maximum transient peak voltage of 1.25kV which is more than adequate for this application.

The choice of relay coil resistance of 1kΩ was chosen to be consistent with the photocell rating as well as an adequate wire gauge for reliability.

Performance and Illumination Levels

The efficiency of the unit is considered in terms of the illumination levels required for switching, the performance of the photoconductive cell and thermistor, and the mean power consumption. The performance of the circuit is shown in Figs. 4, 5 and 6, in which the current is plotted against cell illumination. The three conditions of power line fluctuations corresponding to 264V, 240V and 216V are ± 10% and are also shown in Figs. 4, 5 and 6. These curves take into account temperatures up to 60°C.

If such a high sensitivity is not required of the unit, a masking cover to vary the light falling on the cell can easily be made in the form of an adjustable slit, running the length of the sensitive area. This form of adjustment should be adhered to in preference to a small hole. The slit spreads the light evenly over the sensitive area and so allows the resistance and dissipation to be constant over the cell's element. Hot spots may occur with serious results if a hole is used instead of the slit.

Performance of the Delay Circuit

Fig. 7 shows a curve which depicts the delay between the sudden application of light and the instant at which the street light is switched off. This is the worst expectation for a controller operating at the most sensitive illumination level. In practice, delays in excess of these will be obtained.

Dissipation in the Photocell and Thermistor

A primary aim of the present design has been to obtain long life reliability by keeping the maximum dissipation in both the cadmium sulphide cell and thermistor low.

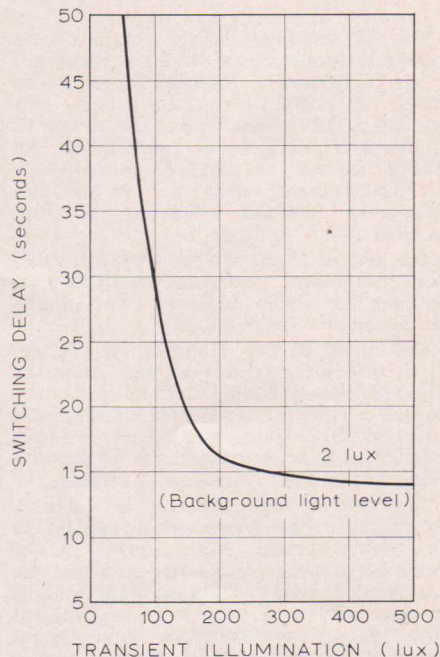

Fig. 7. Typical delay as a function of illumination for background level of 2 lux.

In all cases the thermistor operates well within its maximum rating of 1.8W when the line voltage is excessive and an ambient temperature to 60°C. Maximum dissipation of the cell of 250mW at 70°C is not approached, even under worst case condition of voltage, and the limit is higher at 60°C. The resulting additional dissipations will not have a significant effect on life performance, as this combination of temperature and voltage is unlikely to occur.

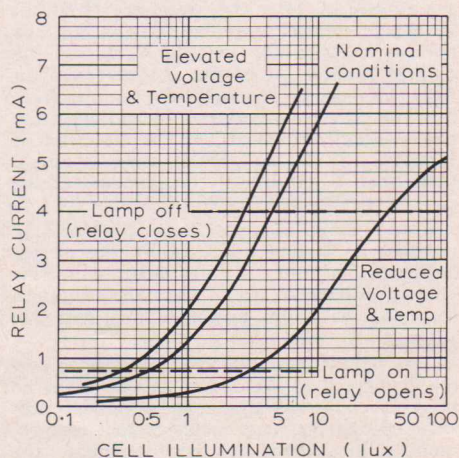

Fig. 8. Complete operating range for different conditions of voltage and temperature.

Power Consumption

The power consumption of the circuit is lowest during the night. The power dissipated under these conditions is mainly dependent upon the values of the potential divider resistors R₁ and R₂.

FIVE - WATT TRANSISTOR WITH CLASS A

The 5W amplifier design described here is suitable for mono or stereo applications. It has a frequency response of 50c/s to 20k/cs at 5.0W, the distortion at this level being less than 0.5%. The design is simple and economical, employing an AD140 operated in class A, preceded by an AC128 driver stage and an OC44N low noise junction transistor as pre-amplifier.

The use of 26dB overall negative feedback contributes greatly to the quality of reproduction which in every way merits the description "high quality".

The circuit of Fig. 1 shows one channel of a three-stage direct-coupled amplifier having extremely good DC stability. Direct-coupled circuits use fewer components, have lower coupling losses and, when correctly designed, possess better temperature stability than conventional AC coupled stages.

The output stage operates in class A and the 15Ω load is capacitance-coupled to the output choke. The output power obtainable depends to a large extent on the thermal design of the output stage and its associated heatsink, as well as ambient temperature requirements. An output power of about 5W under domestic conditions can be obtained with the output transistor mounted on a blackened 4" length of Mullard heatsink extrusion, Type 35D4CB.

Circuit Operation

The fundamental direct-coupled configuration in which the amplifier of Fig. 1 is based is shown in Fig. 2. The driver transistor TR₂ operates as an emitter follower in a circuit which is made virtually independent of transistor characteristics. In this circuit R₁ and R₂ form a low-resistance potential divider providing a voltage V₁ at the emitter of TR₁. This transistor functions as a difference amplifier comparing the voltage V₁ with the voltage V₂ across the emitter resistor R₅ of the output transistor TR₃. The circuit automatically sets itself so that the difference between V₁ and V₂ is the base-emitter voltage of TR₁ (of the order of 150mV). If V₁ is greater than about 3 volts, then V₂ is virtually independent of the characteristics of TR₁.

Line voltage changes cause proportional changes in V₁ and hence in V₂, the output collector current, I_{c(3)} and collector-emitter voltage V_{ce(3)}. Thus the optimum load for maximum power output does not vary greatly with supply voltage.

The AD140 with its common emitter cut-off frequency of the order of 4kc/s can be used in good quality audio amplifiers provided the driver stage meets certain requirements. For class A output stages, the driver stage should be capable of providing drive power in excess of the normal low-frequency requirements of the output stage. The amount of extra drive needed depends on the power versus frequency response requirements of the amplifier. Hence, the emitter follower driver stage should operate at a greater current level than the base of the output transistor. Again the extra current depends on the power response requirements of the amplifier. The driver system

should also be capable of providing excess voltage swing.

The circuit of Fig. 2 is modified to meet the above requirements, as shown in Fig. 3. In this circuit R₁ ensures that the driver transistor TR₂ operates at a higher current than the base of the output transistor TR₃. The potentials V₁ and V₂ are made some-

transistor (an AC128) to be maintained at a moderate value. The use of an OC44N in the first stage, enables a large amount of overall negative feedback to be applied, whilst retaining an ample margin of stability. A small amount of local feedback in the OC44N stage reduces the effective gain spread.

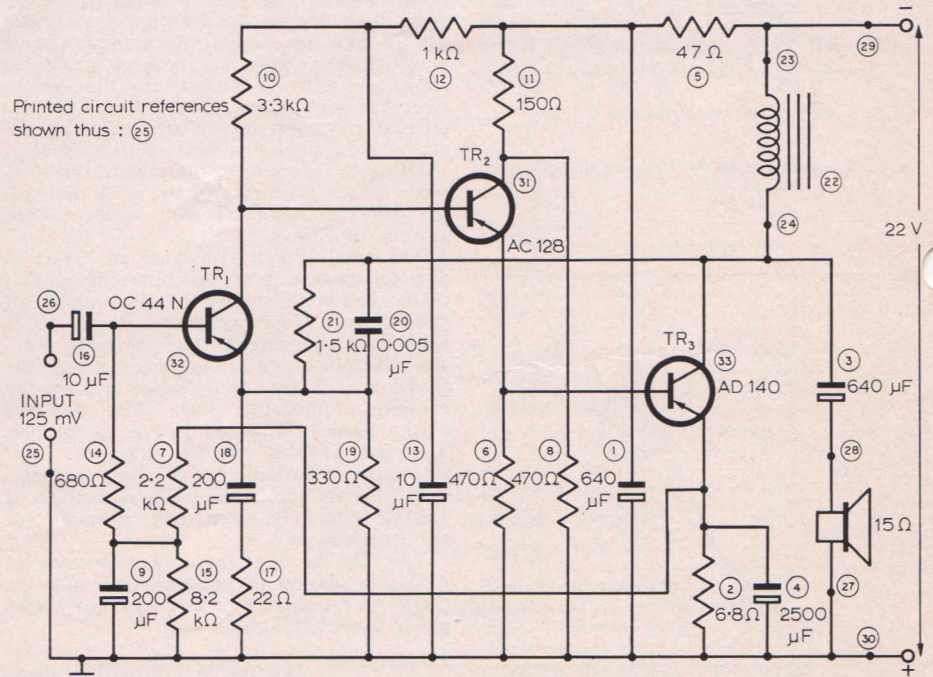

Fig. 1 5W class A amplifier circuit.

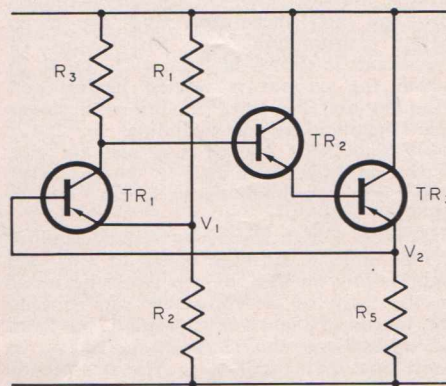

Fig. 2. Basic direct-coupled configuration.

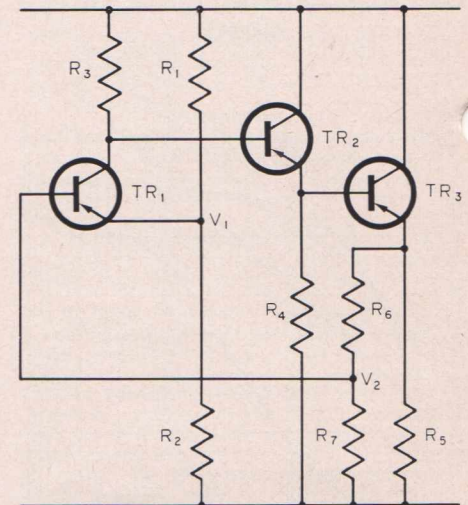

Fig. 3. Modified basic circuit.

what lower than the potential at the emitter of the output transistor, thus ensuring that excess voltage drive is available from the collector of the transistor TR₁. The value of R₃ is such that the collector current is much greater than the base current of TR₂.

Circuit Description

The high gain figure of the AD140 enables the dissipation of the driver

The reference voltage for the emitter of TR₁ is provided by resistors 19 and 21. The voltage applied to the base of the transistor TR₁ is provided by resistors 7 and 15. Feedback is taken from the emitter of the

HIGH-QUALITY AMPLIFIER OUTPUT STAGE

AD140 output transistor and applied to the base of the input transistor via resistor 14. Residual audio voltage from the output stage is reduced by means of capacitor 9.

Resistor 21 also serves as part of the potential divider, resistors 17 and 21 which provides AC negative feedback. The capacitor 20 across resistor 21 reduces ringing when a square wave pulse is applied to the input of the amplifier.

Resistors 8 and 11 set the collector-emitter voltage of TR₂, thereby reducing the dissipation to within the transistor ratings.

Capacitor 4 decouples the emitter resistor 2 of TR₂. This capacitor should have a low series resistance and its ripple rating should be equal to the AC current in the output transistor.

The 15Ω loudspeaker is capacitance-coupled to the output choke. The inductance of this choke determines the low frequency response of the amplifier. Its DC resistance should be low (less than 2Ω) to minimise copper losses. The 15Ω load is optimum for power outputs of the order of 5W using the AD140.

The feedback resistor 17 and the capacitor 18, form a phase-advance-network in the feedback loop which counteracts the phase lag introduced by the output choke at low frequencies. If the time constants of capacitor 18 plus resistor 17, and that of the output circuit are made equal, the net phase shift in the feedback loop is zero, resulting in excellent low-frequency stability.

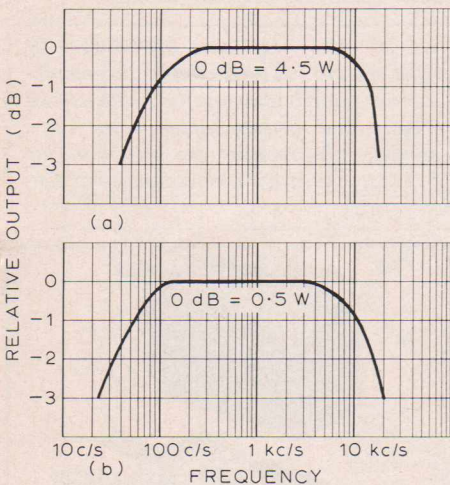

Fig. 4. Frequency response of amplifier (a) at 4.5W and (b) at 0.5W.

Performance

The frequency responses at low and at high power levels are given in Fig. 4. Ringing and overshoot with a pulse waveform input is kept to a minimum as the rise time of the amplifier is 20μs.

The total harmonic distortion as a function of power output is shown in Fig. 5. The sensitivity of the amplifier is 90μA for 5W output. The output impedance is approximately 0.8Ω at 1kc/s.

Power Supply

A suitable power supply for both stereophonic and monophonic versions of the 5 watt transistor high quality amplifier is shown in Fig. 6. Two Mullard BYX20-200R silicon power rectifier diodes are used in a full-wave rectifier configuration. A 2" length of Mullard 35D blackened heatsink material (Type 35D2CB), or its equivalent, is used to maintain the silicon diodes at a safe operating temperature. Adequate smoothing is achieved using a 2,000μF, 50VW electrolytic filter input capacitor, the resistor R and at the output of the power supply, a 4,000μF, 25VW electrolytic capacitor, (to accommodate existing components two 2,000μF capacitors may be connected in parallel instead of the one 4,000μF, 25VW electrolytic capacitor).

It is important that the filter capacitors are returned directly to the centre tap of the power transformer, thus preventing the formation of hum-loops by the high ripple currents. The resistor R should be adjusted to provide a voltage of -22V to both channels. The approximate value of this wire-wound 10W resistor, is 6.8Ω.

The mains transformer used in the prototype amplifier, Type No. PF 2440 has a conventional 240V primary, a shield winding and a 24V-0-24V r.m.s. secondary

→ Page 60

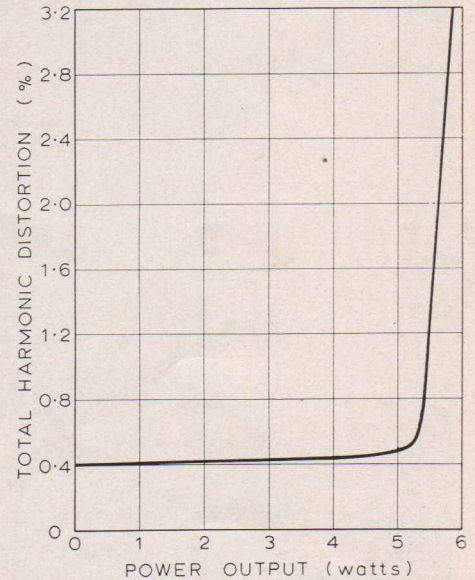

Fig. 5. Total harmonic distortion plotted against output power.

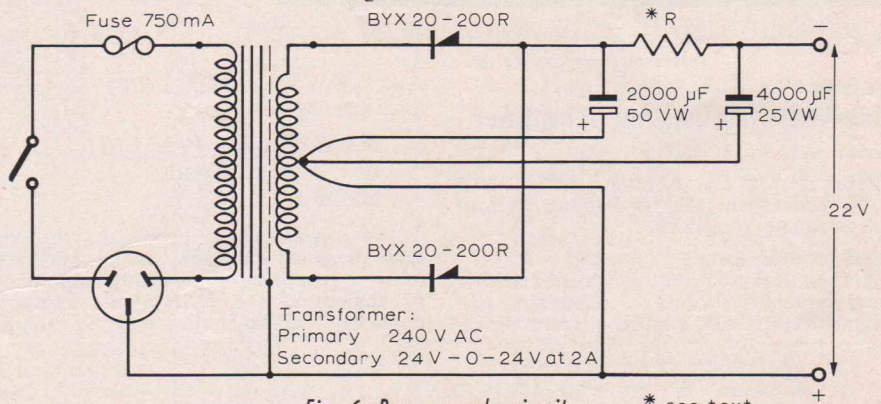

Fig. 6. Power supply circuit. * see text

TABLE OF COMPONENTS AND PRINTED WIRING BOARD REFERENCE NUMBERS

1.	640	μF	25	VW	Electrolytic capacitor	16.	10	μF	16	VW	Electrolytic capacitor
2.	6.8	Ω	5	W	Wire wound resistor	17.	22	Ω	½	W	Resistor
3.	640	μF	25	VW	Electrolytic capacitor	18.	200	μF	6	VW	Electrolytic capacitor
4.	2500	μF	6	VW	Electrolytic capacitor	19.	330	Ω	½	W	Resistor
5.	47	Ω	1	W	Resistor	20.	0.005	μF	200	VW	Polyester capacitor
6.	470	Ω	½	W	Resistor	21.	1.5	kΩ	½	W	Resistor
7.	2.2	kΩ	½	W	Resistor	22.	Choke				TRS236
8.	470	Ω	½	W	Resistor	23.	Choke black lead				—
9.	200	μF	6	VW	Electrolytic capacitor	24.	Choke yellow lead				—
10.	3.3	kΩ	½	W	Resistor	25.	Input (earth)				—
11.	150	Ω	½	W	Resistor	26.	Input (125mV)				—
12.	1	kΩ	½	W	Resistor	27.	Loudspeaker voice coil (earth)				—
13.	10	μF	16	VW	Electrolytic capacitor	28.	Loudspeaker voice coil (active)				—
14.	680	Ω	½	W	Resistor	29.	-22V supply				—
15.	8.2	kΩ	½	W	Resistor	30.	+22V supply and earth				—
						31.	Mullard AC128 Transistor				
						32.	Mullard OC44N Transistor				
						33.	Mullard AD140 Transistor				

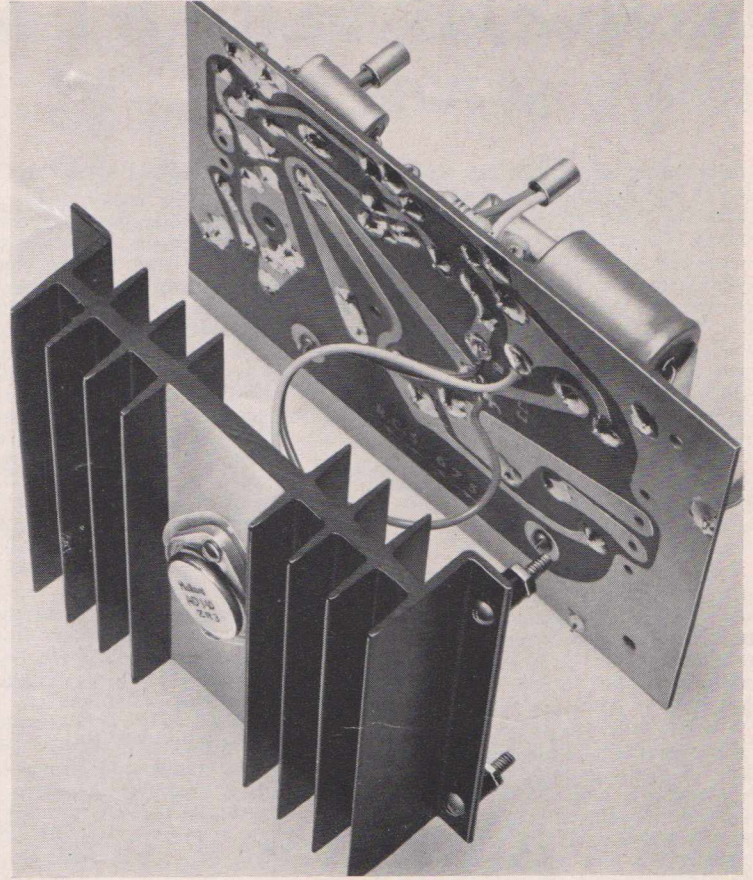
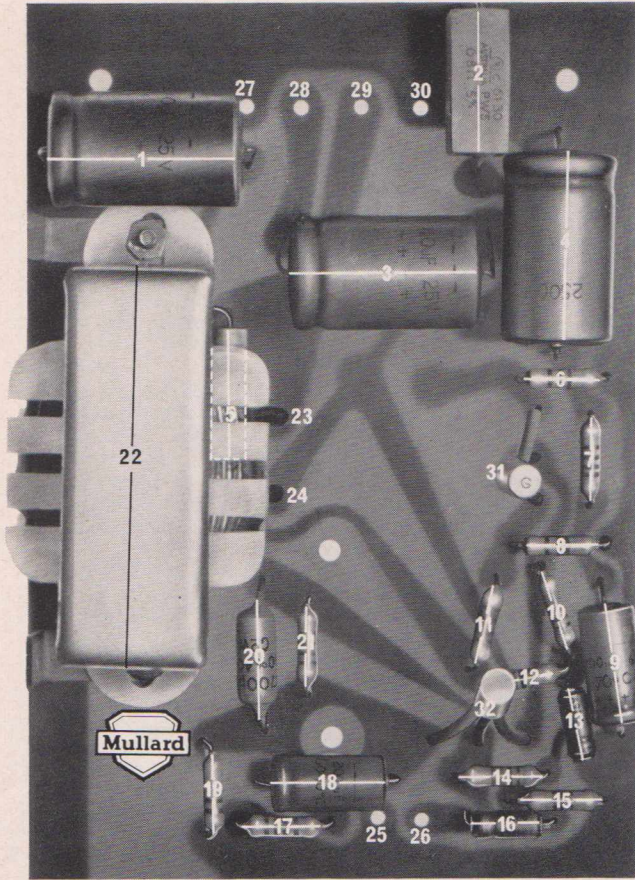

Fig. 7. Suitable layout for a printed wiring board with circuit reference numbers shown.

Fig. 8. The printed wiring board and the heatsink extrusion form a compact sub-assembly.

← Page 59

Five-Watt Transistor Amplifier (cont.)

winding rated at 2A. A 750mA fuse is fitted in the primary of the transformer to provide adequate protection.

Constructional Details

A suitable layout for the printed wiring board is shown in Fig. 7. Boards to this design together with a kit of all parts neces-

sary to construct this amplifier, are readily available from:

R.C.S. Radio Pty. Ltd.,
651 Forest Road,
BEXLEY. N.S.W.

The printed wiring board and the heatsink extrusion for the output transistor, form a compact sub-assembly which may be duplicated for stereophonic reproduction. The sub-assemblies may be mounted

into any convenient, adequately ventilated space within the amplifier cabinet. ■

NOTE. The next issue of OUTLOOK (Vol. 8, No. 5) will contain a comprehensive description together with circuit details and constructional notes of a suitable pre-amplifier for use with the five-watt transistor high-quality amplifier.

ERNI RELAY TYPES 20 KW & 20 KWW

The latest addition to the range of components is the relay type 20 KW offered by Mullard in Australia. This relay is equipped with a micro-switch featuring positive snap action to minimise contact wear and arcing. It may be used under normal conditions to switch up to 4A at 240V AC.

DC Resistance and Type Numbers

The preferred DC resistance of the relay magnet is 1,000Ω. This value is a suitable compromise of wire gauge, adequate reliability and optimum sensitivity, which is of the order of 400mW.

Relays may be obtained with either a single changeover contact (Type No. 20 KW) or with two changeover contacts (Type No. 20 KWW).

Terminals

The relay terminals are designed in such a way that they can be used with conventional wiring or inserted into printed wiring boards.

Reliability

Generously proportioned contacts are used and the coil is impervious to humidity thus ensuring a high degree of reliability. The pressure necessary to switch each contact is individually adjusted during manufacture, providing a high repetition rate and uniform sensitivity. The relay has been specially designed to withstand shock and vibration. ■

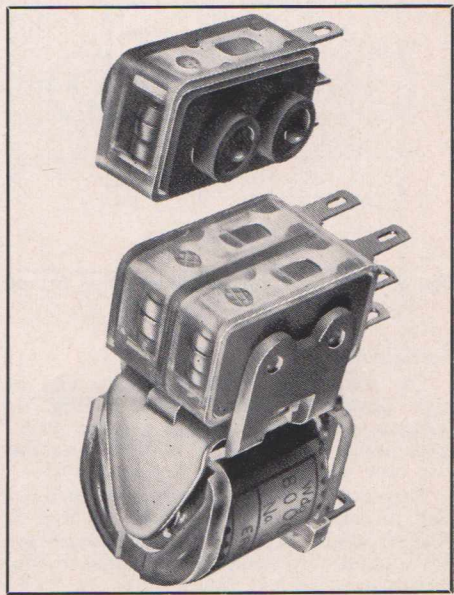

MICROWAVE COOKING – Part II

At present, microwave ovens are commercially available in two major ratings of approximately 500W to 1kW and 2 to 2.5kW and certain commercial installations for continuous belt feed up to 5kW.

In this article a low cost 1kW oven is discussed with a new directly heated packaged magnetron contributing to its simplicity and reliability and providing an area for new market development.

The main factor contributing to the simplicity of this smaller oven is the development of the new packaged magnetron type DX206. This directly heated magnetron is operated at the full heater current during the whole of the work period. Previous CW magnetrons for microwave cooking required complicated circuit design to reduce the heater current progressively during the work period. A further advantage of this 1kW oven is that it does not have to be a fixed installation, as current consumption is within the rating of a general purpose outlet. Also, the cost of two small ovens (which, combined, have the same heating power as one large 2kW oven) will be considerably less. Greater flexibility in usage may be achieved by having two small ovens instead of a large one, provided of course, that the smaller individual cooking spaces in the two 1kW ovens are not a limitation. Further, a small oven is more suited for automatic vending of small articles such as pies or hot-dogs.

- in the food during the cooking process.
- The microwave oven is usually constructed of stainless steel and as the energy is dissipated within the load (food) the oven requires no lagging; also the full cooking power is available 5-7 seconds after the oven is switched on.
- Almost all energy is absorbed by the food, the oven and its surroundings remaining quite cool. This fact, together with the short cooking time, results in considerable power saving (up to 75%) when compared with an electric range.
- A considerable saving in food bills will result. In the catering industry, using presently available ranges for keeping food warm, there is considerable wastage, as unsold food which has been kept warm for some time is often unsuitable for serving. This problem is eliminated with a micro-

COMPONENT DESCRIPTION OF THE 1kW MICROWAVE OVEN

The source of microwave energy is the new packaged magnetron DX206 with Ticonal permanent magnets shown with its power supply and ancillary equipment.

The magnetron power supply is current regulated by means of a saturable reactor in the primary of the EHT transformer. Series stacked silicon diodes are used in a bridge rectifier-circuit because of space limitations and the high PIV encountered. It is more economical to leave the rectified output unfiltered and this also eliminates possible filter losses. A conventional diode rectifying bridge is used to supply control current to the saturable reactor transformer. A separate heater transformer, which is at cathode potential, supplies 120W to the quick-heating filament.

Other main items shown in the diagram are the ancillary components:

- The air flow from the blower is via air filters at the side of the cabinet and is first drawn through the transformer compartment and thence blown through the magnetron cooling fin chimney and along a duct terminating at the top of the oven, the one blower being used to cool the whole of the device and in addition to expel the moist air from the cooking compartment.
- A thermal switch is fitted above the anode as a protective device to prevent overheating of the magnetron.
- The timer, which is of the simple clock-work type, provides for timed intervals of up to 3 minutes, as well as incorporating the 'ON' switch.
- Because of the magnetron operating at a potential of about 4.5kV r.m.s. and the high microwave energy encountered, interlocking safety micro-switches are provided, one for the back cover and another at the door.
- Not seen in the illustration, but on the periphery of the inside of the door is a built-in continuous quarter wave stub which at the operating frequency effectively presents a high impedance to unwanted stray radiation.

It is apparent from the above that the oven and magnetron operating circuit is relatively simple. The greatest care is necessary, however, to ensure that the oven and the door do not radiate microwave energy at levels which may be harmful to persons in the immediate vicinity. Furthermore, a large number of low power measurements at the operating frequency of 2.45Gc/s are necessary, to ensure that the magnetron is properly matched to the oven cavity under all possible load conditions. Failure to achieve proper matching may result in immediate breakdown of the magnetron when the oven is switched on or, at best, a greatly curtailed operating lifetime.

Z. Uzdy,
Applications Laboratory,
Sydney.

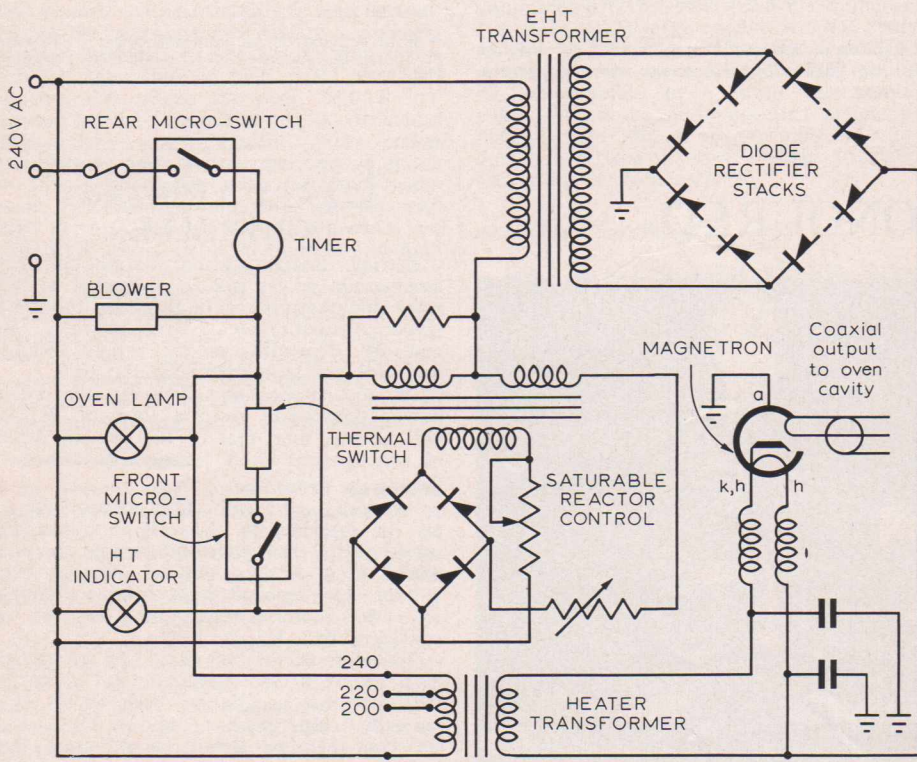

Circuit diagram of prototype oven

The net result is an oven with the following advantages over presently available electric ranges:

- Shorter cooking times are provided. At the 1kW level only 25 seconds are needed to heat 1/4 lb. of typical food from a refrigerated temperature of 3°C to a serving temperature of 80°C; or 20 seconds to cook, say, frankfurters. This rapid cooking time has, of course, the added features of enhanced flavour and less vitamin loss

wave oven, as food can be rapidly reheated as the rate of consumption demands. Moreover, a wider range of menus can be provided, and local food processing firms are already engaged in the preparation of foods suitably packaged and presented for microwave cooking. Microwave cooking is ideally suited for the reheating of pre-cooked food with wide application in cafeterias, motels, passenger aircraft and so on.

EF86 STILL FURTHER IMPROVED

INDUCED HUM REDUCED 75%

Stray alternating magnetic fields associated with the leakage flux from the mains transformer and tape transport motor can present problems in domestic valve tape recorders. These fields can induce hum into the first amplifier valve by causing deflections of the electron beam within the valve.

The amplitude of hum induced in this way depends on the amplitude of the alternating field and the orientation of the valve in the field. An orientation exists in which the hum induced by a given field will be a minimum, but experience has shown that, with conventional valves, this orientation does not always remain constant from valve to valve or even for a specific valve in a specific amplifier.

The variation is attributable to the influence of changes in the magnetic flux density residing in the outer screen of the valve. This residual flux density depends on the magnetising effects of stray magnetic fields and the demagnetising effects of vibration or shock. The level of induced hum thus depends on outside influences that cannot be predicted, so that preset methods of reducing the hum, such as "humbucking" are ineffective.

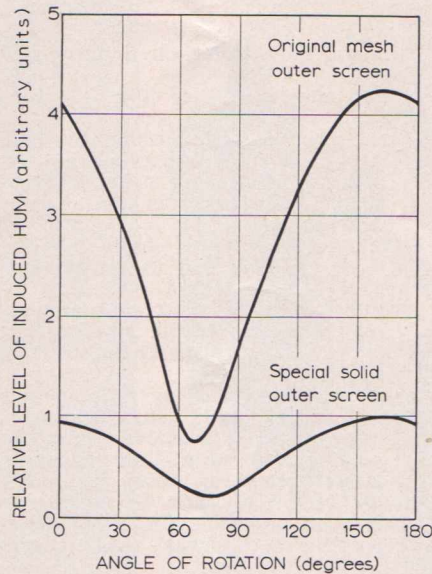

Variation of induced hum with angle of rotation for the EF86 with mesh screen and solid screen.

Some manufacturers attempt to reduce the level of induced hum by isolating the valve from the alternating field by means of an external screening-can placed around the valve. This method is likely to be only partially successful, because the screening-can usually consists of thin metal, and the screening is consequently not complete.

In the Mullard EF86*, more effective isolation is now provided within the valve itself. The conventional mesh outer screen has been replaced in all EF86 valves by a solid screen of a special grade of grain-orientated silicon steel. The effectiveness of this screen is shown in the diagram, where the curves show the variation of induced hum with the angle of rotation of the valve in the magnetic field, for the EF86 valve incorporating the original mesh outer screen and for the improved construction incorporating the solid outer screen. The curves indicate a reduction of more than 75% in the maximum level of induced hum, and a considerable reduction of the minimum level.

* More detailed design information for EF86 may be found in Volume 1 of the Mullard Technical Handbook.

PIONEER HONOURED



Mr. S. R. Mullard, M.B.E. (left) founder of the Mullard company in 1920 and one of the electronics industry's best-known pioneers, receives the City & Guilds of London Institute Insignia Award in Technology (Honoris Causa) from the chairman of the Institute, Mr. A. M. Holbein, C.B.E., F.C.G.I., D.I.C., B.Sc.(Eng), M.I.C.E.

The presentation was made at the Yearly Meeting of the Institute, held at Clothworkers' Hall, London.

← Page 57

STREET LIGHTING CONTROLLER

During daylight, when the photocell is conducting, power is also dissipated in the relay and thermistor. In this case the total power dissipation may vary between 1W and 4W, depending on the supply voltage and ambient temperature at the time.

In most applications, however, the mean power dissipation over a 24-hour period will be less than that of the present types of synchronous clock timing mechanisms.

Setting-up Procedure

As mentioned previously, a masking cover can be attached to the cell to adjust its sensitivity to the light conditions at the site where it is to be installed. Supply line voltage and ambient light level variations are two factors which have to be a consideration.

To calibrate, the unit should be connected to a supply of the same nominal value as that on the installation site. With the ambient temperature at about 25°C, the slit can then be slowly closed until the lamps switch on at the required ambient light level applied to the unit. The switch-off level is automatically set by the circuit backlash to be a few lux higher than the switch-on level.

This method of setting-up has the advantage that the ratio of switching levels remain constant, irrespective of the setting of the adjusting mask.

G. F. HUGHES

Applications Laboratory—Sydney.

References:

Mullard Technical Handbook Vol. 4, Part IV, Mullard Technical Communications No. 69, March 1964.

FERROXCUBE FOR TRANSFORMERS

Systems of mutually coupled inductive windings form networks which may be used either to transmit electrical energy or to match impedances between adjacent sections of complex electrical circuitry. To improve the efficiency of the coupling between these windings, they are usually wound onto a core of soft magnetic material.

The Advantages of Ferroxcube Cores

In most transformer applications, the core is chosen to have a high effective permeability and to be of a convenient shape to achieve a small ratio (l/A) of magnetic flux path length (l) to core cross-sectional area (A) and have a large enough winding area to minimise the winding losses. The initial permeability of magnetic materials decreases with increasing frequency. The permeability-frequency characteristic of transformer metals shows a fall from a high value at very low frequencies to a much lower value at only a few hundred cycles per second, while ceramic ferroxcube materials, although having lower initial permeabilities overall, maintain this value over a frequency range extending to many megacycles per second. As permeability is also dependent on the operating flux density, a different design approach is necessary for transformers operating at high fields than for transformers where the peak field is low enough for the permeability to be considered independent and constant. For power transformer applications operating at 50c/s or 400c/s, and lower audio frequency wideband transformers, laminated metals with high permeabilities at these frequencies and which are also capable of operating at high flux densities, are undoubtedly of most use to the designer. The use of ferroxcube materials becomes advantageous at frequencies above about 400c/s for wideband transformers, pulse transformers and in power applications where the core losses, principally eddy current loss, become an important limiting factor in the design.

Transformer Design

In general, the design of a particular transformer requires that the number of turns and the turns ratios have to be determined, and that the effective loss, phase shift and return loss must be kept within specified limits. At the operating frequency or the lowest frequency in wideband applications, a primary impedance must be chosen to be compatible with the impedances of the adjacent circuits and also related to the required high frequency response. In this respect, the value of impedance chosen will also depend on whether the residual core losses ($\tan \delta$) are appreciable at this frequency and whether there is any DC polarisation in the core. If

the preferred primary shunt inductance (L_p) for the transformer is calculated, then an effective loss equal to $\omega L_p/R$ is obtained where $\omega = 2\pi f$ and R is a summation of the resistance of the adjacent circuits.

The peak flux density expressed either by

$$B = \frac{E \times 10^8}{\pi \sqrt{2} Af} \text{ (gauss)}$$

or by

$$B = \frac{4\pi \sqrt{2} \mu NI}{10l} \text{ (gauss)}$$

where E is the voltage, N is the number of turns, and I is the current in amperes.

This may be calculated to determine the distortion at frequency (f). For most ferroxcube materials, the flux density may be operated at a maximum of approximately 2500 lines per square centimetre. If the power to be transmitted is now introduced into the design, a core of the required volume may be selected to have a minimum l/A ratio and a large enough winding space for low winding loss. The effect of a DC polarising field on the core is to modify the permeability to a lower incremental value. When the milliamp-turns per centimetre exceed 500, an air gap must be introduced in ferroxcube core systems to avoid saturating the core material.

Available Core Shapes

There is a wide range of core shapes available from Mullard for transformer design. These may be chosen from conventional 'E' shapes, 'U' shapes, cup cores and toroids.

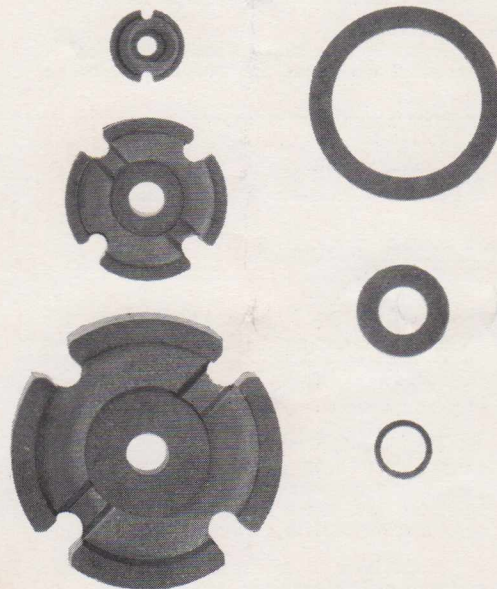
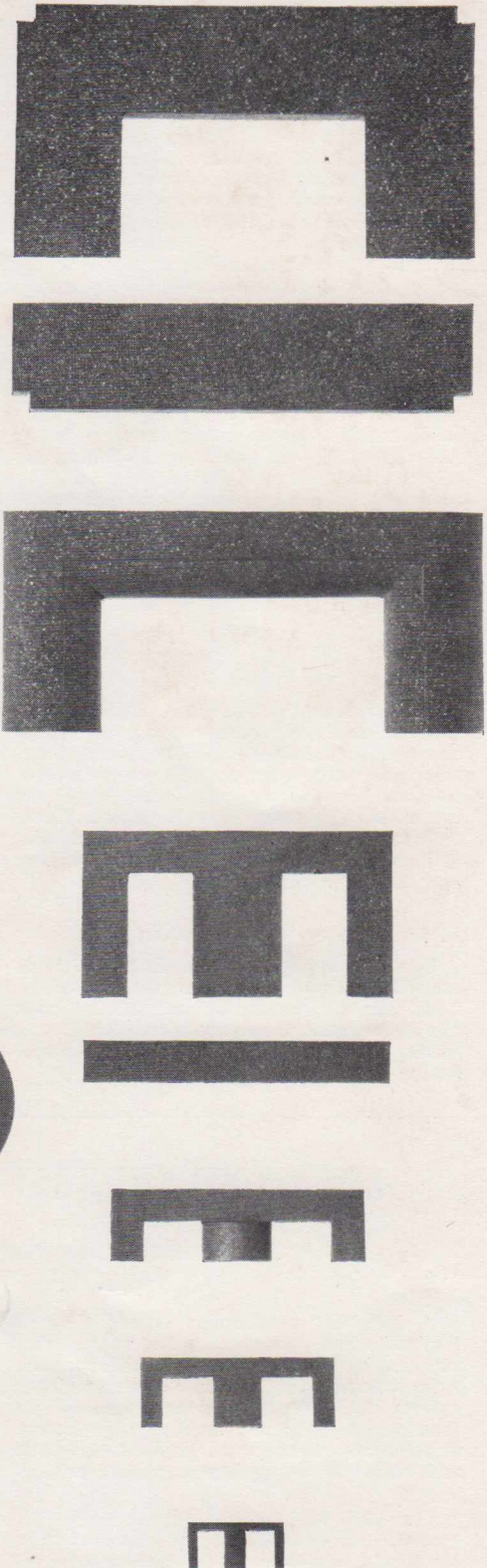

Comprehensive design data and relevant information on Vinkor pot cores and Ferroxcube transformer cores may be found in Volume 6 of the Mullard Technical Handbook and in the Mullard publication "Vinkor Manual" available from Mullard offices and distributors throughout the Commonwealth, priced at 5/3d plus 8d postage.

A representative range of Mullard Ferroxcube Transformer Cores shown at actual size.



MULTI-CAM PROCESS PROGRAMMING SWITCH

This compact programme timing device for high precision switching is capable of handling the most complex switching problems in modern automation engineering. Available with a protective housing it can be used for instrumentation, machinery or automatic control systems.

The construction of the cam switch timer UA 10, based on the kit principle, can be adapted easily to specific applications. The compact design allows considerable saving in space, essential for advanced engineering. Typical elements of the timing gear UA 10 are the individually adjustable micro-switches KS 10 actuated by a new type of doubly adjustable cam discs. The combination of these two variable elements in a cam switch timer offers considerable advantages. The setting or modifying of a predetermined switching sequence can be accomplished on the spot, easily and quickly. The cam discs can be set in steps of three degrees angular rotation and a simple lock prevents shifting. Adjustment of the point of switching of each microswitch is easy; no parts have to be removed. Hand setting is possible without disconnecting the motor driving gear. A set of fixed discs can replace the doubly adjustable cam discs if required. The switch gear can either be driven by hand or by a synchronous motor with or without hand setting.

Basic types and variations

UA 10 is the designation of all Micro-Electric cam disc timers using the basic elements of the above specified dimensions. Additional data are required to complete the specification for any particular type or execution within the UA 10 series. These data include motor drive, number and type of cam discs, shaft specifications, terminals and further details.

Motor drive or hand operation

For most applications the timer UA 10 is normally driven by a synchronous motor 240V 50c/s. The motor and driving gear can be adapted to any required speed. In any motor operated unit additional hand setting is available.

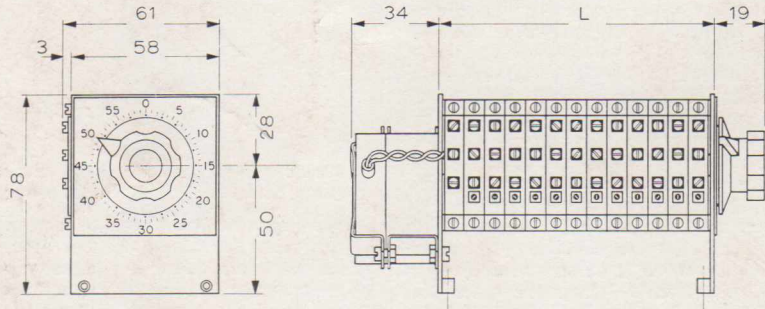
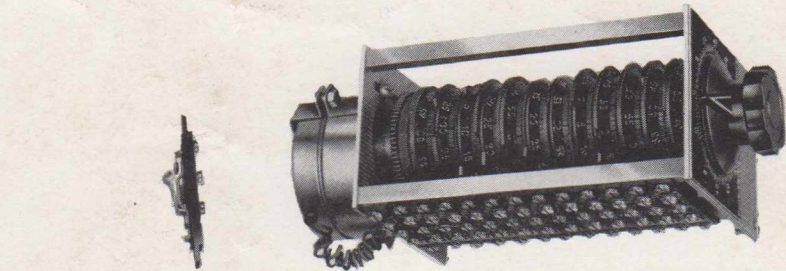

Dimensions in mm

Type UA 10 A 3	with 3 cam discs	L = 36 mm
Type UA 10 A 6	with 6 cam discs	L = 60 mm
Type UA 10 A 9	with 9 cam discs	L = 84 mm
Type UA 10 A 12	with 12 cam discs	L = 108 mm

Cam discs

The timer UA 10 is available either in a standard version with doubly adjustable cam discs or, if required, with fixed cam discs made to specification. The number of discs determines the programming capacity and the overall length of each unit.

Switches

All switching functions are performed by micro-switches type KS 10 and the cam shaft is equipped with ball bearings for high precision switching and easy adjustment. Electrical rating is 5A at 240V 50c/s.

Terminals

According to requirements the following terminal variations are available: screw ter-

minals, solder terminals, AMP quick-connect or flat terminals for direct mounting on printed circuit boards.

For enquiries or ordering please supply the following specifications:

- Operating voltage and frequency
- Shaft speed
- Number of contacts
- Terminals
- Surrounding atmosphere
- Switching diagram or time schedule.

NEW COLOUR TELEVISION PICTURE TUBE — A63-11X

Introduced in the United Kingdom

A 25", 90° rectangular colour tube in PANORAMA presentation is now being supplied by Mullard Ltd. to British receiver manufacturers for use in experimental receivers. It is the first colour tube of its kind which does not require a protective shield similar to the local Mullard A65-11W and A59-11W monochrome picture tubes.

The A63-11X colour tube has a rectangular screen (50.4cm by 39.4cm—19.8" by 15.5"), giving a useful picture area of approximately 1,800cm² (279 inch²). Compared with 70° tubes, the A63-11X allows the cabinet depth to be reduced by about 4" excluding the additional space that can

be saved by the PANORAMA presentation. The 90° scanning angle does not call for extra scanning power because an improved electron gun design has enabled the neck to be narrowed to only 36.5mm diameter.

The A63-11X operates from a 25kV EHT supply with electrostatic focusing, and magnetic convergence and deflection. It incorporates the latest Mullard colour-selecting shadow mask with graded holes.

In addition to colour picture tubes, Mullard provides receiver manufacturers with colour components including yokes, line output transformers and a complete range of complementary valves.

SCIENCE IN THE DEVELOPMENT OF AUSTRALIA EXHIBITION

The venue of this Exhibition was the R.A.S. Showground, Sydney, from 11th to 19th August. The Mullard Stand, which proved most popular with teachers and students alike, featured the Mullard Educational Service.*

A competition was conducted for high school students, with the object of encouraging their interest in electronics. Two devices—"The Magic Candle" and "The Jumping Rings"—were featured and students were invited to submit essays theorising on their principles of operation. Entries are to be judged by a panel of Mullard staff and prizes will be awarded for the three best entries received.

A more detailed description of the Exhibition and the Mullard Stand will be given in the next issue of Outlook.

* See Outlook Volume 8, Number 2, page 15—Ed.