

Mullard

Outlook

Australian Edition

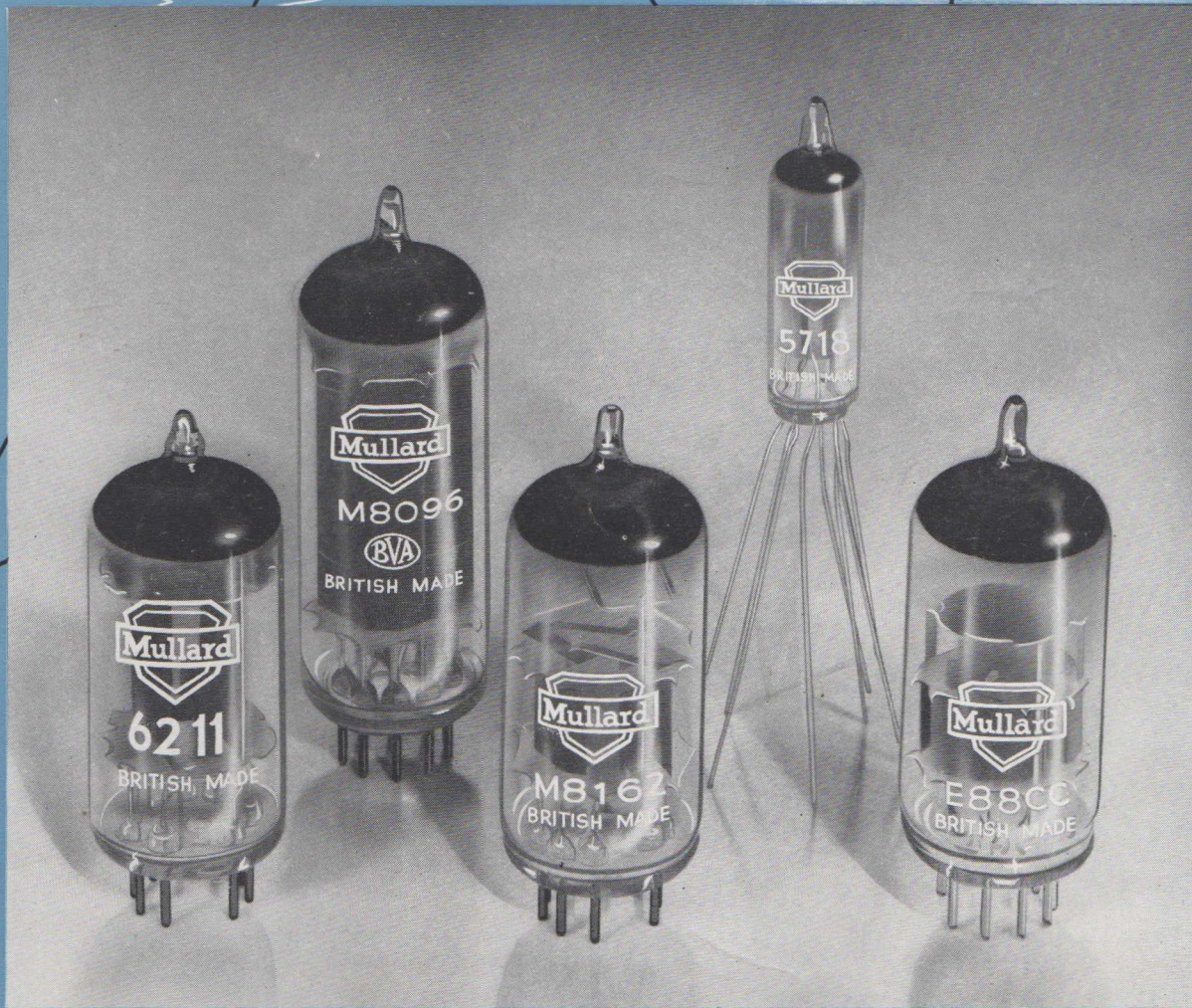

VOL. 3 No. 4 JULY-AUGUST
1960



MULLARD - AUSTRALIA PTY. LTD.



VOL. 3—No. 4

JULY-AUGUST, 1960

Editorial Office:
35-43 Clarence Street, Sydney.
Telephone—BX 2006.

Editorial Staff:
B.P.A. BERESFORD, A.M.I.R.E. (Aust.)
JOERN BORK

All rights reserved by Mullard-Australia Pty. Ltd., Sydney. Information given in this publication does not imply a licence under any patent. Original articles or illustrations reproduced in whole or in part must be accompanied by full acknowledgement: Mullard Outlook, Australian Edition.

CONTENTS

Editorial	38
Effective Retail Display — A Key to Extra Sales	39
Mullard Backs BTQ Tests	39
Mullard-Australia Personalities	39
New Industrial Power Transistors	41
Special Quality Valves	42
100W Transistor D.C. Converter	44
New Leaflets	45
Design of Laminated Circuits	46
Simple Valve Measurements	47
Power Transistor Standard Envelope	48
Mullard N-P-N Transistors	48
For High Speed Computing	48
Amateur Experimenters Column	48

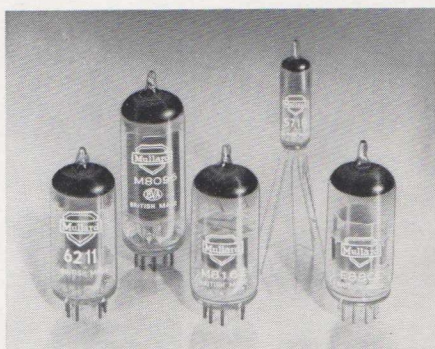

Our front cover depicts a selection from the comprehensive range of Mullard Special Quality Valves. A complete list with equivalents appears on page 43.

MULLARD-AUSTRALIA PTY. LTD.

35-43 CLARENCE STREET, SYDNEY
Phone: BX 2006

123-129 VICTORIA PDE., COLLINGWOOD, N.5
VICTORIA

Phone: 41 6644

Associated with
MULLARD LTD., LONDON.
MULLARD OVERSEAS LTD.
MULLARD EQUIPMENT LTD.

Brief Encounter—The Vital 8 Seconds

The fleeting glimpse, the passing glance, the flicker of an eyelid and, in time, a change in destiny!

From the plumage of bird life to the well dressed retail store—all to attract. Only the shopkeeper has a time limit, the 'vital 8 seconds', which the average person takes to pass his shop window. The vital 8 seconds in which to attract the passer-by, to create the suggestion of responsive interest in his merchandise and the subtle compelling urge to enter his shop.

This theme, Effective Retail Display, as The Key To Extra Sales is presented in this issue of Outlook and we suggest a pensive moment to consider the selective impressions each of us has tucked away—yet latent to draw on. In short, do prospective customers in your area instinctively and favourably link your store with the type of merchandise you sell and service?

MULLARD DISTRIBUTORS:—

NEW SOUTH WALES

Martin de Launay Pty. Ltd.
287 Clarence Street, Sydney
Phone: BX 5834
Cnr. King & Darby Streets,
Newcastle Phone: B 4741

SOUTH AUSTRALIA

Agents:
Woollard & Crabbe Limited
180 Wright Street West,
Adelaide Phone: LA 4713

QUEENSLAND

B. Martin Pty. Limited
35 Charlotte Street, Brisbane
Phone: 2 1744

WESTERN AUSTRALIA

Harris, Scarle & Sandovers
Limited
691 Hay Street, Perth
Phone: 23 0131
Sales & Service
495 Newcastle Street, Perth
Phones: 28 1171, 28 0131

TASMANIA

Medhursts Wholesale Ltd.
163 Collins Street, Hobart
Phone: 2 2911
136 Wellington Street,
Launceston Phone: 2 2091
106 Wilson Street, Burnie
Phone: 1919

VICTORIA

Howard Electrical & Radio
Company
Vere Street, Richmond
Phone: JB 4716

and all leading wholesalers throughout the Commonwealth

EFFECTIVE RETAIL DISPLAY — A KEY TO EXTRA SALES

Have you ever noted how long it takes a person to walk past your shop? Probably not, for as a busy radio and television dealer you have something better to do. But if you did stand in your doorway with a stop watch, you would find (if you have an average size shop) that he would take about eight seconds.

Now if you want that passer-by to study the goods you have in your window, that eight seconds is vital to you. In this short space of time you must take command of his mind, completely change his existing trend of thought, and bring his attention to focus on your merchandise.

INCREASE ATTRACTION, INCREASE POWER

You may think this is a tall order. It is. But you achieve it many times every day, and by careful application of the principles of good retail display you may even be able to increase the attraction of your window. Moreover you will probably be able to increase its power of bringing customers into your shop where you can really get down to the business of selling to them.

Now what are these basic principles of window display? What must your window do to help make customers for you, and what devices do you use to enable it to do this?

REMEMBER — EIGHT SECONDS

First of all, of course, it must attract your passer-by's attention, for if it fails to do this it will not have the oppor-

tunity of doing anything else. Remember — in eight seconds he will be gone. This is no easy task, for you are not only competing against all the other nearby shops, but with the normal movement and interest of the life going on around him as well.

The answer is in making your windows colourful, and by using whenever possible some form of animation. Most people are responsive to colour and very few can resist looking at a moving display.

COLOUR HARMONY

As far as colour is concerned, the brighter shades generally attract attention most easily: in particular vivid reds and yellows. But naturally the colours you choose will be governed to some extent by the goods you are showing and the type of display you are aiming at. It is, of course, essential that the whole window should be in harmony.

Animation may take many forms. Perhaps the simplest is a slowly revolving turntable on which some of your goods can be attractively arranged. Besides its simplicity, it has the added advantage that the goods themselves are moving, and are immediately the centre of interest.

After dark, colour and movement can be introduced together very effectively by the use of flashing coloured lights. Or if you want to be rather more ambitious you can use small motorised dimming resistances to

Continued on Page 40

MULLARD-AUSTRALIA PERSONALITIES



Since joining Mullard some five years ago, Mr. Ron Smith, pictured above, has become well known to our friends in the medical X-ray field, as well as to the many people in industry and research organisations using Mullard electronic test instruments and ultrasonic equipment in a wide range of applications.

Whilst maintaining his interest in these spheres he is now actively associated with our expanding Professional and Industrial Department and will be pleased to assist you with information on valves, tubes and semiconductors for industrial purposes.

Prior to his appointment with Mullard, Mr. Smith gained wide practical experience in many facets of the electrical and radio industries.

Formerly a keen motor cyclist, he now enjoys carrying out routine maintenance on the family car, and spends much of his time in weekend gardening around a new home.

MULLARD BACKS BTQ TESTS

Press Cutting from Electrical Weekly dated 29th July, 1960

Sydney — Mullard - Australia Pty. Ltd. is sponsoring five hours of test pattern transmissions a week from BTQ-Ch. 7. During a recent visit to Brisbane, Mullard General Manager M. A. (Maurie) Brown noted the concern of the Brisbane T.V. trade at the cessation of the 10 a.m.-noon test patterns from BTQ which had been sponsored by the Television Service Assoc. (Old.) members, who, however, were no longer able to continue the sponsorship (WEEKLY 22/7/60, p. 16).

Because there were no early transmissions from any of the Brisbane stations, Mullard approached BTQ with an offer to sponsor the morning tests as a service to the Brisbane trade. Due to a desire to carry out maintenance work, the station is not prepared at present to resume the morning tests, but arrangements were made to transmit afternoon tests for one hour a day, Monday to Friday (12-1 p.m. Mon., Wed., Fri., 3-4 p.m. Tues., Thurs.). It is hoped that the two-hourly morning transmissions will be resumed shortly, when Mullard will transfer its sponsorship to them.

Meanwhile, the present test transmissions, which commenced July 18, 1960, include certain Mullard films. Mullard's Queensland distributors are B. Martin Pty. Ltd.

change window lighting through an infinite variety of shades and brightness levels. The constantly changing hues will lift your display right above the more conventionally lighted windows of the shops either side of yours.

POSTERS AND SHOWCARDS

But when it is not possible to use actual animation or changing lights, you can still give your window "life" in other ways. One very simple method is by using the posters and showcards which are supplied free of charge by large manufacturers. These are designed by experts for this very purpose. They are colourful and present their sales message in easily understood form. They are nearly always pictorial and so do not depend for understanding upon the written word. Many of them include pictures of people in their design, so bringing the added attraction of "human interest" to your display.

When your window has commanded the attention of a passer-by, it has fulfilled one of its most difficult tasks. But its work is by no means finished. The final aim you want to achieve is for him to actually enter your shop as a potential customer. You must do more than attract him. You must interest him in your goods as well, and arouse in him the desire to buy. Your window must be planned to this end.

YOUR GOODS AT A GLANCE

So it is most essential that your prospect be able to see at a glance the goods you are showing. Overcrowding should, therefore, be avoided at all costs. Neither too many articles nor too wide a variety should be crammed into the available space. Your window has a message to give, but a display which tries to say everything very likely says nothing at all. Here again, manufacturers' display material can help to focus interest sharply along a particular line.

To be really effective a window display should have a definite motif or theme. It may be one developed solely for the window, or it may link your display with some other form of publicity.

TIE-IN DISPLAYS

For example, you may wish it to tie in with your local press advertising, or with a manufacturer's national campaign—repeating a message which your customers may have seen in newspapers or magazines. Or you may wish to use your window to back up a direct mail campaign. In this case, for instance, you would show the goods

which you were offering in your circular letters. If catalogues or leaflets were mailed with these, it would be a good idea to include some in your display, too. They would help to link it to the offer you had made through the post.

Another useful way of interesting passers-by who have been attracted to your window is by building your sales story around events of local or topical interest. For instance, your displays can reflect the atmosphere of local holidays or festivities.

LINK WITH THE HOME

Or you can furnish your window as a room in a typical home, enabling you to show your merchandise as it

THE COUNTER AND SHOWROOM

Retail display does not end in your windows, however. Point of sale displays on your counter and in your showroom take over where windows leave off. So they should be a natural follow-on from your window display, reminding your customer of his need for your product and his desire to buy it.

But point of sale displays need not have the urgency of your window messages, for they are read only by the customer who has troubled to enter your shop. He must already be interested to some extent in your goods and so you can offer him a longer message



RETAIL DISPLAY DOES NOT END IN YOUR WINDOWS . . .

would be in actual use. This technique is very fully used by many stores and helps to create a desire in the customer to own the article for his own home.

These are just a few of the hundreds of ways in which windows may be made more interesting and stimulating to the public's imagination.

To help your windows maintain the power of attracting customers they should be changed regularly. People are inclined to disregard displays which they know are not changed frequently. And if a high standard is maintained, your customers may actually look forward to seeing your new windows. When this stage has been reached, your window is more valuable than ever to your business.

than would be effective in the window.

Here you can extend your theme. You can, for instance, put manufacturers' literature to hand so that customers can read a fuller specification of the goods displayed.

CO-OPERATION OF MANUFACTURERS

Here, in fact, you can take full advantage of the co-operation of manufacturers. Display materials supplied by large concerns are colourful, attractive, neat and quickly set up. Their catalogues and leaflets give the features of their products in immediately readable form. And, most important of all, they are designed by display experts, especially to help you sell their goods.

Very often manufacturers point-of-sale material ties in with their national advertising campaigns. The retailer who displays this material therefore stands to benefit from the extra sales that these campaigns promote.

Counters are a most useful place for displays, because it is here that customers are most likely to read your sales messages — while waiting their turn for service, for instance, or while their purchases are being wrapped, or while waiting for change.

BRIGHT COLOURS AND MOVEMENT

We stressed in the first part of this article that colour and animation should be used to attract attention to your windows. Bright colours and movement are equally important for your interior displays and the fullest possible use should be made of them. But here space often limits the size of the items used. Manufacturers realise this when designing counter cards, and small, well designed cards and cut-outs are always available.

POSTERS REPEATING YOUR MESSAGE

Posters are always welcome items in your general displays, and may very well be duplicates of those in your window. They will repeat the message of your window display and help to keep customers' minds on the theme you have designed for its selling quality.

SPECIAL DISPLAYS

For special occasions, such as your exhibitions, the opening of a new branch and other feature periods, it is often possible to borrow special displays for a week or so. These are very often animated and are always designed to attract and hold attention. Naturally enough the demand for such items is extremely heavy and manufacturers often have long waiting lists for them.

Carry the principles of display to your shelves as well. They should be well filled but not overcrowded. Large articles should be discreetly arranged in your showroom, with enough room between them for customers to examine models comfortably.

SIMPLICITY IS IMPORTANT

Finally, do keep your displays simple whether they be in your window or in your shop. Ruthlessly discard any features which conflict with the main theme. Overcrowded display space looks smaller than it

NEW INDUSTRIAL POWER TRANSISTORS

	(a) V_{cb} max	(b) V_{ce} (0.5A)	(c) V_{ce} (6A)
OC28 Highest voltage, close tolerance α'	80V	60V	60V
OC36 High voltage, medium gain	80V	60V	32V
OC29 Medium voltage, highest gain	60V	48V	32V
OC35 Gen. purpose 12V applications	60V	48V	32V

Power transistor application limits were discussed on page 44 of Outlook, Volume 2, No. 4, and this article presents a range of new power transistors capable of providing controlled performance under high voltage high current conditions.

These conditions occur in practice when, for example, a transistor which has closed an inductive relay in its collector, is suddenly switched off, whereupon the back EMF due to the inductance of the solenoid, causes a high voltage to appear between the collector and emitter.

The designer requires a transistor that will withstand the voltage stresses imposed by the circuit and at the same time may call for as much gain as possible in the output stage. The gain requirements are much less stringent in the case of self driven circuits, such as D.C. converters, where a narrow spread in gain is rather more important than the absolute value.

It appears to be an unfortunate physical fact that high voltage hold-off at high collector currents is not usually coincident with high gain. Under these conditions, the four new power transistors provide different compromises between voltage and gain, to suit the varying needs of the equipment designer.

Characteristics for these types are given in the table below where the values quoted give the maximum hold-off voltage under collector breakdown in common base or common emitter cut-off conditions, 0.5A and 6A in common emitter respectively.

really is, and the greater the distance from which it is viewed, the more confusing it looks. A good window display should entice people to cross the road to it: a good interior display should entice customers into your showroom.

Good displays result from careful thought, planning and attention to detail. They take time to produce, but the extra profits they will give you will more than repay your efforts.

This article was prepared by MR. RONALD CARTER of Mullard Publicity Division.

OC28

Examination of the characteristics shows that the correct choice for 24V D.C. converters is the OC28 since it allows the highest collector voltage both under cut-off and high current conditions and has a narrow current-gain spread. Its current gain is relatively low, however, this is not important in most D.C. converter applications.

OC36

The OC36 has the same cut-off voltage as the OC28 and the same hold-off voltage at 0.5A collector current, but because of its higher average gain, the collector hold-off voltage at 6A must be reduced to 32V. This transistor—the OC36—represents a compromise between gain and hold-off voltage and could perhaps, be regarded as the general purpose 24V accumulator transistor.

OC29

The OC29 has a maximum cut-off voltage of 60V, and a maximum hold-off voltage of 48V at 0.5A and 32V at 6A. This transistor represents a really high gain transistor, the voltage being the best that can be achieved with this high gain. Indeed, a minimum gain of 35 at 6A is quite unusual in power transistors and is, we believe, something of an achievement.

OC35

The three types listed above are intended to operate mainly from 24V power supplies. The fourth transistor, the OC35, is a lower voltage type intended for use with 12V systems. Here less stress is imposed on the transistor by circuit requirements and this one type is all that is necessary for most 12V applications.

Power transistor specifications need to be exacting if they are to stand up to the conditions met even in normal use. These four power transistors represent a great advance on earlier types and are indeed capable of making quite a name for themselves in their respective fields. Tentative abridged information is given in the table.

LONG LIFE – SPECIAL QUALITY – RUGGED

Different manufacturers use wide variations in terminology to describe valves having some desirable properties over and above those normally claimed for the general run of entertainment types. We think it is useful to try to indicate what might be inferred from these various terms.

It should be remembered that, with a few very minor exceptions, none of these terms has been publicly defined by a responsible standardisation authority. It is only possible, therefore, to examine what has happened in the past and what appears to be common usage today, and to conclude, from this examination, the most generally accepted definitions.

Ruggedness and Reliability

Historically, the "rugged" valve was the first large scale attempt on the part of the valve industry to do something about the **mechanical** weaknesses in the valves which were then being used in airborne equipment, without paying any special attention to the control of **electrical** characteristics. The early "reliable" valve, on the other hand, was the first large scale attempt to control both electrical and mechanical failures with a view to achieving a higher probability of operation in a given equipment.

Theoretically, therefore, a "rugged" valve is one whose rate of failure for mechanical reasons is low, but whose rate of failure for purely electrical defects is not affected by the term "rugged" and may therefore be high or low. A "reliable" valve, on the other hand, must clearly be one for which certain claims are made concerning its reliability (or probability of continuing to operate satisfactorily) under certain stated conditions. It depends entirely on these conditions whether or not the "reliable" valve need be "rugged."

In practice, however, this strictly accurate and wide definition of the term "reliable valve" is not generally employed. In common usage it is also taken to imply some degree of mechanical ruggedness, simply because the major market for these valves is in applications where some mechanical vibration occurs. Indeed, it may be said that in many quarters the term is taken to imply a valve designed specifically for aircraft use.

Special Quality

In an attempt to create a new general term, more comprehensive than the term "reliable," it was agreed to adopt in Britain the term "special quality." Subsequently, it appears, this term has found some favour in America also.

Ideally, a "special quality" valve may be defined as one having:

- (a) a declared standard of performance maintained over a declared period of time; and
- (b) a declared maximum rate of failure during this period, a failure being defined as some declared degree of departure from the performance defined in (a),

the clauses (a) and (b) applying only when the valve is operated under stated electrical, thermal, and mechanical conditions.

It will be seen that the term "special quality," far from having a limited meaning, is extremely wide and general. Ironically, at the present moment the major effort in special quality valve work has been directed towards the manufacture of valves intended for Services' airborne and vehicle-borne applications, and once again the general term is in danger of being limited to valves intended for these applications.

Practical Specifications

The problem of making, defining, and using a special quality valve is not simple. It is frequently difficult for the user to define his application requirements precisely, and it is also very difficult for the valve manufacturer similarly to define his claims. As a result, the present situation is that certain Services' specifications (British Government CV4000 type, or the relevant American MIL type) are the only basic special quality specifications having any degree of general acceptance. In these specifications some attempt has been made to define the minimum performance which a batch of valves may show when subjected to certain mechanical and electrical sampling tests; and it is intended that these specifications shall give the user some idea of the claims being made under clauses (a) and (b), given above. From such a specification it is also intended

that the user may attempt to relate his own operational conditions to those used to control the valve, and to make some estimate of the failure rate he may expect to see in his equipment.

Many years have elapsed in the process of creating these specifications and evolving manufacturing techniques to produce valves to this standard; and the standard has tended to become more rigorous at the same time. Meanwhile, the user has clamoured for something better than the normal valve: and for this reason many valve makers have offered valves incorporating certain constructional improvements, and better methods of manufacturing control, than were previously employed in normal valve production. These valves undoubtedly gave the user a somewhat better assurance of satisfactory operation; but, because of lack of experience and insufficient time in which to make extremely lengthy assessments, it was not possible for the valve maker to offer a precise and clearly defined claim under the clauses used above to define "special quality." To meet this temporary expediency, and to meet each manufacturer's natural desire to have an exclusive name by which these valves might be known, terms such as "Plus" etc., were introduced.

Long Life

Although the bulk of the effort in the special quality valve field has been devoted to types intended for Services' use, several valve makers in Britain and America have manufactured valves designed to achieve a low rate of failure over a long life (10,000 hours or more) with less emphasis on the mechanical properties which are usually required in Services' valves. Such valves, whilst properly deserving the title "special quality," are often offered as "long life," "telephone repeater," or "professional" valves. In general, these types are intended for use in telephone equipment, instrumentation equipment, etc., where long life and control of electrical characteristics are of paramount importance.

This general introduction will be followed by further articles in which the problems of long life, reliability, and statistical control will be discussed in greater detail.

— RELIABLE — PROFESSIONAL PLUS ? ? ?

This list shows some valves whose primary Special Quality feature is rugged mechanical construction and others whose primary Special Quality feature is long life. Designers are recommended to consult individual data sheets for further details.

Special Quality Production			Description	Base	Standard Production		
Commercial type number	Services type number	American Equivalent			Commercial type number	Services type number	American Equivalent
E80CC	—	6085	Double Triode	B9A	—	—	—
E80F	CV2729	6084	A.F. Pentode	B9A	—	—	—
E80L	—	6227	Video Pentode	B9A	—	—	—
E81L	—	6686	Output Pentode	B9A	—	—	—
E83F	—	6689	A.F. Pentode	B9A	—	—	—
E88CC	—	6922	Double Triode	B9A	—	—	—
E90CC	—	5920	Double Triode	B7G	—	—	—
E91H	—	6687	Heptode	B7G	—	—	—
E92CC	—	—	Double Triode	B7G	—	—	—
E180CC	—	7062	Double Triode	B9A	—	—	—
E180F	CV3998	6688	High Slope R.F. Pentode	B9A	—	—	—
E182CC	—	7119	Double Triode	B9A	—	—	—
M8079	CV4025	‡6058	Double Diode	B7G	EB91	CV140	—
M8080	CV4058	‡6100/6C4WA	V.H.F. Triode	B7G	EC90	CV133	6C4
M8081	CV4031	‡6101/6J6WA	Double Triode	B7G	ECC91	CV858	6J6
M8082	CV4063	‡6516	Output Pentode	B7G	EL91	CV136	—
M8083	CV4014	‡6064	R.F. Pentode	B7G	EF91	CV138	—
M8091	CV4044	‡6443	Half-wave Rectifier	B9A	EY84	CV2235	—
M8096	CV4039	‡6062	V.H.F. Power Tetrode	B9A	QV03-12	CV2129	5763
M8097	CV4059	—	Diode-triode Mixer	B7G	EAC91	CV137	—
M8098	CV4048	—	Voltage Reference Tube	B7G	85A2	CV449	5651
M8099	CV4070	—	Grounded-grid Triode	B7G	EC91	CV417	—
M8100	CV4010	‡5654/6AK5W/6096	R.F. Pentode	B7G	EF95	CV850	6AK5
M8136	CV4003	‡6189/12AU7WA	Double Triode	B9A	ECC82	CV491	12AU7
M8137	CV4004	‡6057	Double Triode	B9A	ECC83	CV492	12AX7
M8161	CV4015	‡6065	Variable-mu Pentode	B7G	EF92	CV131	—
M8162	CV4024	‡12AT7WA	Double Triode	B9A	ECC81	CV455	12AT7
M8163	—	—	Voltage Stabiliser Tube	B7G	150B2	CV2225	—
M8190	CV4066	‡5783WA	Subminiature Voltage Reference Tube	**	—	—	—
M8195	—	—	Low hum, low microphony Pentode	B9A	EF86	CV2901	—
M8196	CV4011	‡5725/6AS6W	Short suppressor-base Pentode	B7G	6AS6	CV2522	6AS6
M8204	CV4018	5727/2D21W	Tetrode Thyatron	B7G	EN91	CV797	2D21
M8206	—	—	Voltage Stabiliser Tube	B7G	90C1	—	—
M8212	CV4007	‡5726/6AL5W/6097	Double Diode	B7G	6AL5	CV283	6AL5
M8223	CV4020	0A2WA	Voltage Stabiliser Tube	B7G	150C4	CV1832	0A2
M8224	CV4028	0B2WA	Voltage Stabiliser Tube	B7G	108C1	CV1833	0B2
M8225	CV4080	—	Voltage Stabiliser Tube	B7G	75C1	—	—
5636	CV3928	5636	Short suppressor-base R.F. Pentode	B8D/F	EF730	—	—
5644	CV3987	5644	Voltage Stabiliser Tube	B8D/F	—	—	—
5718	CV3930	5718	U.H.F. Triode	B8D/F	EC71	—	—
5840	CV3929	5840	R.F. Pentode	B8D/F	EF732	—	—
5899	CV477	5899	Variable-mu R.F. Pentode	B8D/F	EF731	—	—
5902	CV4029	5902	A.F. Output Pentode	B8D/F	EL71	—	—
6021	CV3986	6021	U.H.F. Double Triode	B8D/F	ECC70	—	—
6205	CV2432	6205	R.F. Pentode	B8D/F	EF734	—	—
6211	—	6211	Double Triode	B9A	—	—	—
6463	—	6463	Double Triode	B9A	—	—	—

‡ The American types shown in the third column of this table have the same electrical characteristics as the appropriate Mullard Special Quality type and they may, in general, be regarded as interchangeable. In the case of those types marked ‡ there are, however, certain differences in the test specifications.

** Three-lead 10mm subminiature.

100W TRANSISTOR D.C. CONVERTER

It is felt that service engineers might like to read a description of a recently developed transistor d.c. converter capable of an output of over 100W from 28V supplies.

HOW IT WORKS

On connecting the supply to the circuit in Fig. 1, because of unbalance, one of the transistors, say Tr1, will begin conducting, causing its collector voltage to swing towards zero by very nearly the supply voltage. The voltage building up across the primary of the output transformer T2 is applied across the primary of the drive transformer T1 in series with a feedback resistor R_f . The secondary windings are so arranged that the transistor Tr2 will be reverse biased and will remain cut off, and Tr1 will be held in the bottomed condition.

As soon as the core of transformer T1 reaches saturation, rapidly increasing primary current causes an additional voltage drop across the feedback resistor R_f . This drop reduces the drive, and the collector current of transistor Tr1, which was bottomed, starts to decrease causing in turn the reversal of the polarities of the voltages in all windings. Transistor Tr1 is rapidly driven to cut off and transistor Tr2 is switched on. This transistor continues in this state until the negative saturation of the transformer is reached.

The circuit switches back to the initial state and the cycle is repeated. The oscillation then continues at a frequency determined by the design of the saturating transformer T1 and the value of the feedback resistor R_f .

For reliable starting the transistors are initially biased into conduction by using a resistor and a diode (R1 and D1, Fig. 1). The external base resis-

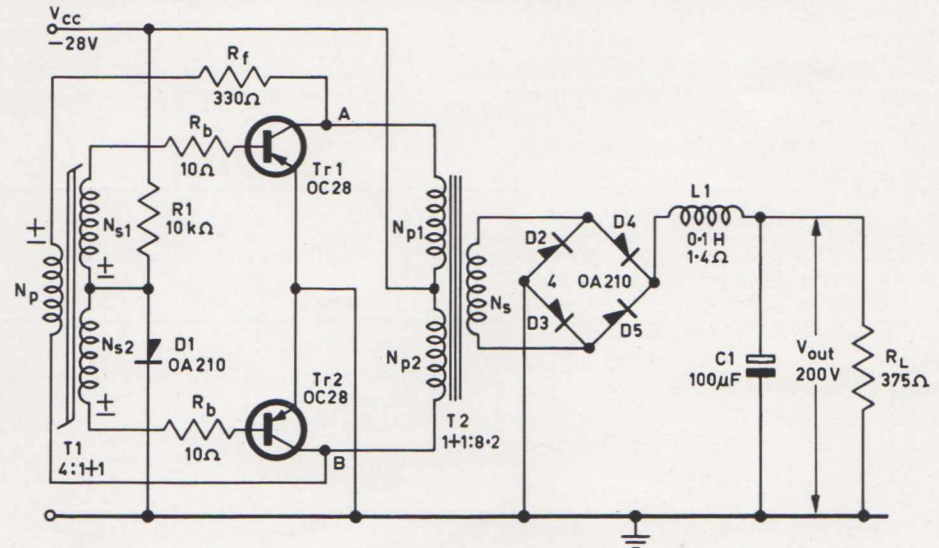

FIG. 1

tors are added to reduce the effect of V_{be} on the operation of the circuit.

The collector current in either of the output transformer and the feedback current needed to produce the drive. Because the output transformer is not allowed to saturate, the magnetising current is only a small fraction of the load current.

PRACTICAL CIRCUIT

The circuit shown in Fig. 1 is derived from a detailed consideration of all the factors governing transistor converter design. The calculated values of components have been rounded off to preferred values, and harmful effects of production spreads in transistors have been almost eliminated.

PERFORMANCE

The performance of this converter was thoroughly investigated: details and comments now follow.

Input voltage	28	V
Input current	4.3	A
Input power	120	W
Frequency	500	c/s
Ripple voltage	220	mV
Output voltage	195	V
Output current	529	mA
Output power	103	W
Efficiency	86	%

Over the range of temperature from -10°C to $+80^{\circ}\text{C}$ the performance was hardly affected. Reduction of copper losses in the output transformer can lead to a higher output and an efficiency of about 90%.

The load current and supply voltage were varied over a wide range of values and the results obtained are shown graphically in Figs. 2 and 3.

Fig. 2 shows the variation with load current of output voltage, output power, efficiency and operating frequency (curves a, b, c, d respectively). Fig. 3 shows the variation with input voltage of the same values as Fig.

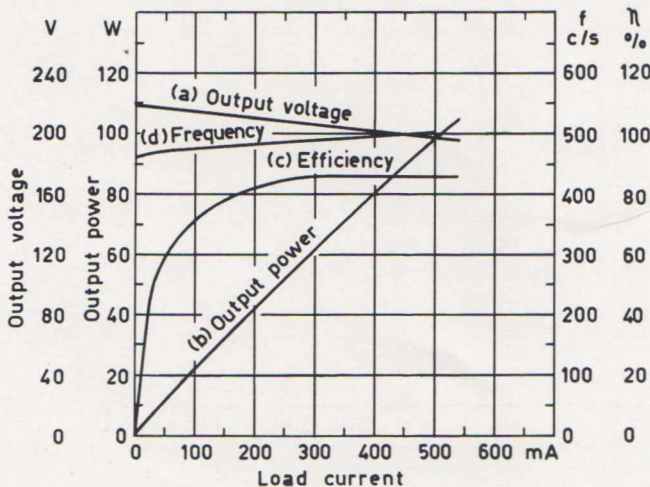

FIG. 2

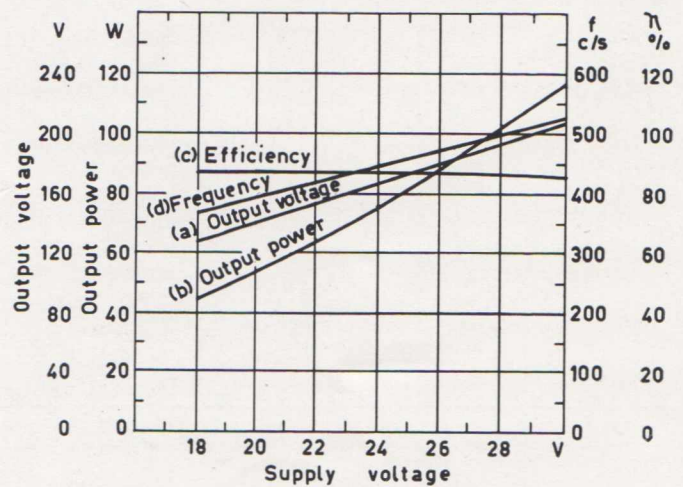

FIG. 3

2 (curves a, b, c, d respectively).

Fig. 4 shows the collector voltage and current waveforms of the two-transformer d.c. converter working under full load conditions. The collector current waveform for a purely resistive load is shown in Fig. 4b. With a small capacitance across the load, the output transformer starts to ring. As a result the collector current (Fig. 4c) rises to a higher peak value. If the capacitance is much higher, the oscillation is damped and the collector current does not rise to such a high value (Fig. 4d). It must be emphasised at this point that the maximum peak current rating of the transistors must not be exceeded.

The disadvantage of a large capacitive load is that it can affect starting when it short circuits the load initially. If this occurs a surge limiting resistor could be connected in series with the load, being progressively short-circuited when the converter is switched on.

In order that the converter may operate satisfactorily with a large capacitance across the output, it is necessary either to reduce the load current or, much the better solution, to use a resistive or choke input filter. The collector current waveform when

the latter is used is shown in Fig. 4e. The spikes at the beginning of the waveform are due to the inductance of the transformer and choke, and must not exceed the maximum peak current rating.

Satisfactory operation of the d.c. converter (Fig. 1) under these conditions can be obtained by reducing the value of R1 to 3.3 k Ω and replacing the diode D1 by a resistor, R2, of 3.3 Ω . Performance figures for this modified circuit are given alongside.

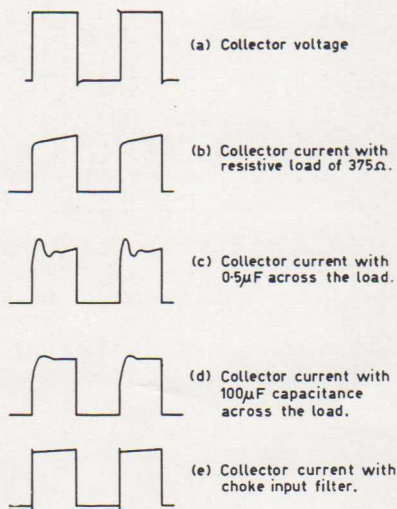

FIG. 4

Input voltage 28	V
Input current 4.36	A
Input power 122	W
Frequency 510	c/s
Output voltage 193	V
Output current 526	mA
Output power 101	W
Efficiency 83	%

SUMMARY OF TRANSFORMER DETAILS

Saturating Drive Transformer T1

Core material.
H.C.R. alloy pattern 224, 50 laminations.
(Telcon Australia Pty. Ltd. 47 York Street, Sydney).
Bobbin.

Insulated Components and Materials Ltd., Type 187A.

Primary winding
227 turns of 34 s.w.g. enamelled copper wire.

Secondary winding
57+57 turns (bifilar winding) of 30 s.w.g. enamelled copper wire.

Linear Output Transformer T2

Primary windings
Bifilar wound, each winding inductance = 70 mH, resistance < 0.2 Ω .

Secondary winding
Resistance < 15 Ω .
Turns ratio 1+1:8.2.

NEW LEAFLETS

Following numerous requests for articles appearing in earlier issues of Outlook, reprints of "Transistorised Inverters and D.C. Converters" and "Modulator Design with OC26 Transistors," have been prepared. In addition to these, two new leaflets featuring valve and transistor equivalents are available.

The new valve index provides a ready cross reference between European and E.I.A. type numbers, and is fully up-to-date with current valve types.

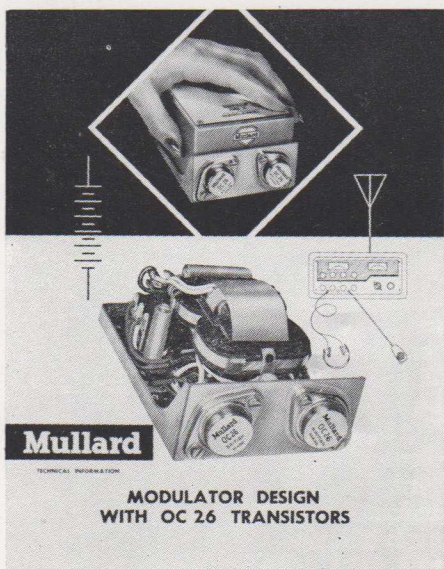

The transistor interchangeability list shows direct equivalents where possible and suggests comparable types in all other cases. When replacing existing transistors with comparable types it is always advisable to check the operating conditions, thus ensuring

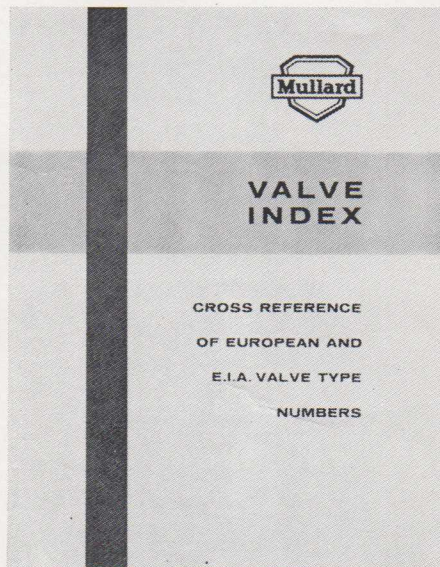

that the replacement transistors are operating with a reasonable margin of safety. When replacing IF transistors with comparable types it may be found necessary to alter the value of neutralising capacitor (where used) in order to prevent instability

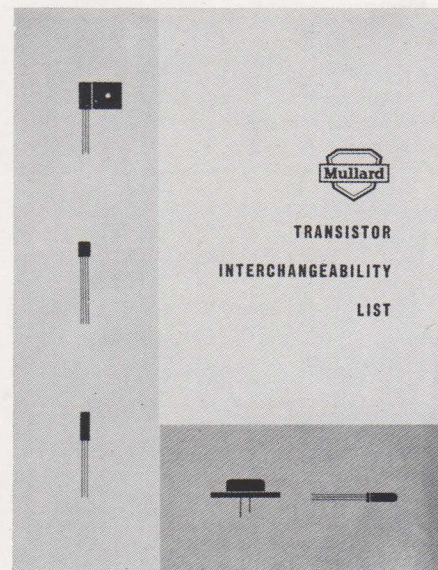

at the intermediate frequency. Where n-p-n transistors have to be replaced by p-n-p types the change in polarity must be kept in mind and, whilst this may be slightly more difficult with printed circuits, experience proves that the problem is not insuperable and such replacements will often contribute to the repair of an otherwise useless device. The leaflets mentioned above may be obtained free of charge on receipt of a stamped addressed foolscap size envelope.

DESIGN OF LAMINATED CIRCUITS FOR INDUSTRIAL R.F. GENERATORS

(Continued from Outlook, Vol. 3, No. 3, May-June, 1960)

PERFORMANCE

Cold Frequency-check

When assembled and excited the circuit resonated at 26.8Mc/s, which is within 1.2% of the design frequency.

R.F. Operation

Table 1 shows performance figures for a TY3-250 valve operated in the circuit shown in Fig. 6(a) as shown in the first half of this article on pages 34 and 35, Vol. 3, No. 3 of Outlook. The laminated circuit was incorporated and the whole assembly tightly screened except for the Faraday screen cut-out. With correctly adjusted feedback phasing, an improvement of about 1% of the anode efficiency could be obtained by moving the r.f. return connection. This was moved from its original position on one of the stabilising bolts to a finger strip connection running across the whole set of plates. The best position of this connection, for maximum anode efficiency, was found by experiment to be half way along the capacitive section of the circuit (Fig. 6b).

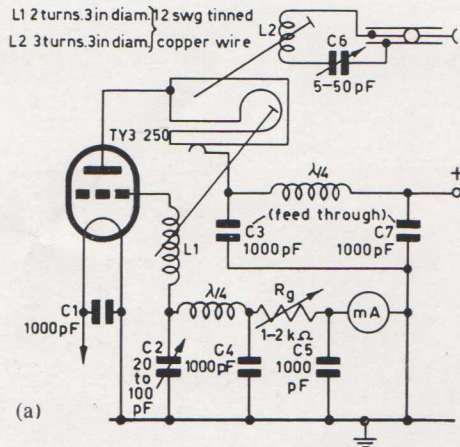
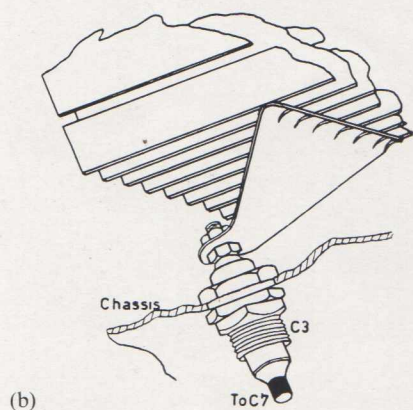

FIG. 6



The resulting maximum frequency deviation

$$\Delta f_o = \pm 40 \text{ kc/s}$$

when the power transfer was reduced by a factor of ten by means of reactive changes (ΔX_L and ΔX_C) in the load coupling circuit.

Analysis of Results

From these results

$$Q_L = \frac{675^2}{9.95 \times 310} = 148.$$

From the first column in Table 1, the power in the circuit

$$P_c = P_{out} - P_{drive} - P_{load} \\ = 310 - 27 - 230 \\ = 53W \\ \text{or } \eta_c = 83\%.$$

Similarly, from the second column

$$P_c = 305 - 22.7 - 225 \\ = 57.3W \\ \text{or } \eta_c = 81.5\%.$$

If this slight discrepancy is disregarded and an efficiency of 82% is assumed with P_c equal to 55W without appreciable radiation loss, the surface resistance of the laminated circuit

$$R_s = \frac{P_c}{I_c^2} = \frac{55}{68^2} = 0.012\Omega.$$

	η_c	Practical limitation of Q_o	Volume*	Screening	Com-parative cost*
Conventional coil, additional capacity	65	—	1	extra	1
Low resistance strip, additional capacity	75	—	1.2 to 1.5	extra	1
Capacity loaded coaxial line	83	1500	5 to 6	self	10
High Q_L cavity	85	2000	7	self	20
Laminated circuit	82	1000	1	extra	1

* Approximate values only.

This is a comparative table detailing various features of the laminated circuit with other types of circuit of the same loaded-Q.

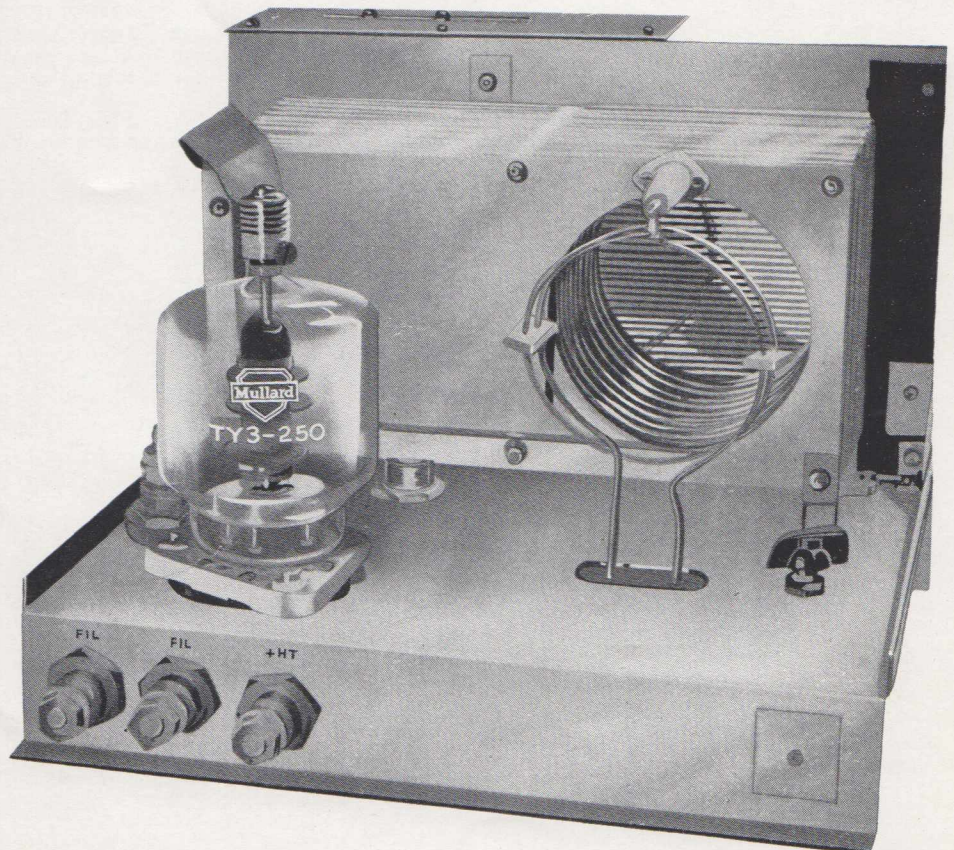

The load was a Termaline wattmeter matched into the tank circuit through a Faraday screen by means of a series-tuned loop. Coupling properties of the laminated circuit were extremely good. Momentary overloads up to 50% had no appreciable effect on the stability of oscillation.

TABLE 1

	$f_o = 27.1\text{Mc/s}$		
ϕ	140°	160°	
V_a	1.2	1.2	kV
I_a	375	375	mA
I_g	95	95	mA
V_g	152	105	V
P_a	140	145	W
η_a	69	68	%
R_{g-r}	1.6	1.1	k Ω
T_a	740	750	°C
P_{in}	450	450	W
P_{out}	310	305	W
η_{load}	51	50	%
P_{load}	230	225	W
P_{drive}	27	22.7	W

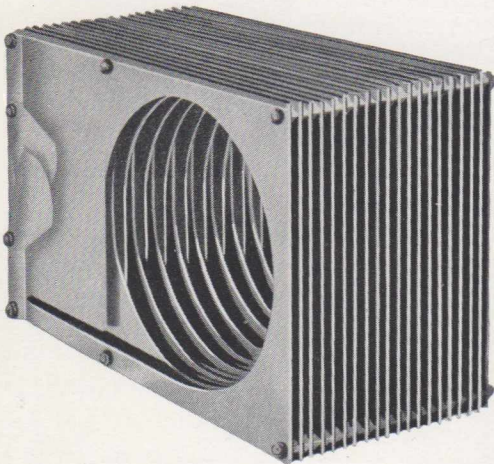
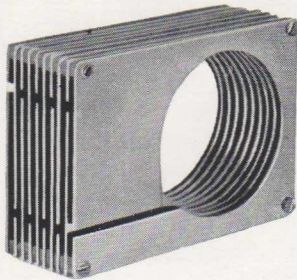

FIG. 7

Because the circuit is very compact direct measurement of the unloaded-Q is extremely difficult. By calculation

$$Q_o = \frac{100}{100 - \eta} Q_i = \frac{100.148}{100 - 82} = 823.$$

SIMPLE VALVE MEASUREMENTS

This article is the fifth of a series now being published in Outlook dealing with experiments for the examination of the properties and behaviour of thermionic valves. These experiments include measurements from which the characteristic curves of various types of valves may be plotted.

The curves of Fig. 8 (see Outlook 3.3) show that, with $V_a = 200$, a change of grid voltage from -4 volts to -2 volts causes the anode current to increase from 5.0 mA to 12.0 mA. This will only be true, however, if V_a remains constant at 200 volts. In practical applications V_a will not remain constant, but will decrease, and the increment of anode current will therefore be smaller.

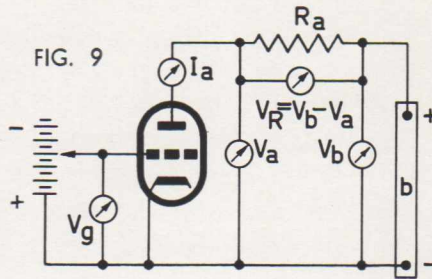

This can be explained by reference to Fig. 9, which shows a typical triode circuit in which b is the source from which the anode circuit is supplied, and R_a represents the resistance of the "load," that is to say the apparatus connected in the anode circuit.

The terminal voltage of the anode voltage source is V_b , and the anode voltage, V_a , is therefore equal to $V_b - V_R$ where V_R is the voltage drop across R_a .

When, by changing V_g , I_a increases, V_R (which is equal to $R_a \times I_a$) also increases, so that V_a (which equals $V_b - V_R$) decreases. NOTE.—There will also be a further small decrease of V_a due to the increased voltage drop across the internal resistance of the anode voltage source.

The I_a/V_g characteristic under these "dynamic" conditions is therefore flatter than the static characteristic, as indicated in dotted line in Fig. 10.

The dynamic characteristic can be derived from the static characteristic by drawing on the family of (I_a/V_a) curves, a "load" line representing the load resistance R_a .

This construction can best be explained by a practical example. Assume that the working point of the valve corresponds to $V_a = 200$ volts and $V_g = -4$ volts (Point A in Fig. 10) and that R_a , the load in the anode circuit, is 25,000 ohms.

At this working point, the anode current is 5 milliamperes, so that the voltage drop across R_a is:

$$V_R = I_a \times R_a = 0.005 \text{ A} \times 25,000 = 125 \text{ V}$$

It follows, therefore, that for an anode current of 5 mA at $V_a = 200$ volts, V_b must be:

$$V_b = V_a + V_R = (200 + 125) \text{ V} = 325 \text{ V}$$

The load line is constructed by joining point A to point B on the voltage axis corresponding to 325 volts, and producing the line to cut the current axis at C.

If, now, with V_b maintained at 325 V, the grid voltage is varied, the corresponding values of I_a and V_a will be represented by the line BC, and the value of I_a at any value of V_g can be determined from the intersection of the load line and the I_a/V_a curve for the particular value of V_g . These values of anode current, plotted against the corresponding values of V_g , give the dynamic I_a/V_g characteristic shown in dotted line in Fig. 10.

Since the mutual conductance of the valve is represented by the slope of the I_a/V_g characteristic, and since the slope of the dynamic characteristic is less than that of the static characteristic, it follows that the mutual conductance under practical operating conditions is less than that measured in the laboratory.

Similarly the dynamic amplification factor is less than the static value, and is, in fact,

$$\text{equal to } \frac{\mu R_a}{R_a + r_a}$$

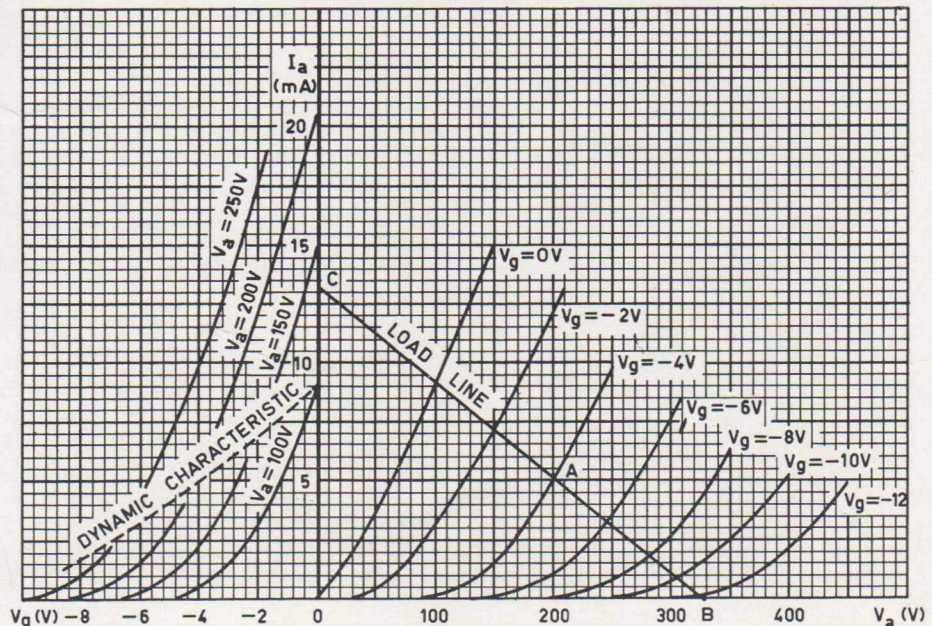

FIG. 10

POWER TRANSISTOR STANDARD ENVELOPE

There has been much discussion throughout the world on standard envelopes for both small signal and power transistors. The problem of standardisation is complicated by various factors such as the need to obtain long life, to have an envelope which can be manufactured at reasonable cost and in some cases the need for small size consistent with high heat dissipation offers problems not easy to solve.

While the low wattage transistor envelope problem is still largely unsettled, the power transistor situation is somewhat more stable. Most power transistors manufactured in the U.S.A. and the United Kingdom are based upon some variant of the simple outline shown below. Methods of construction vary, but at the present time there appears to be little disagreement with its length, the standard fixing hole dimensions or the total seated height.

The new Mullard OC28, OC29, OC35 and OC36 transistors are constructed in this standard envelope. Users of power transistors are advised to change over to types using this envelope as soon as they possibly can. While one cannot be certain that transistor technology will always lead to the use of this envelope, any standard which is arrived at by natural evolution, rather than by arbitrary standardisation, should have great stability.

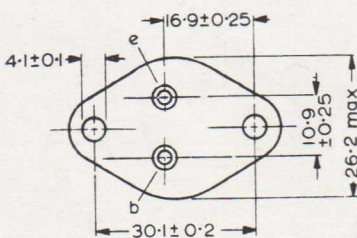
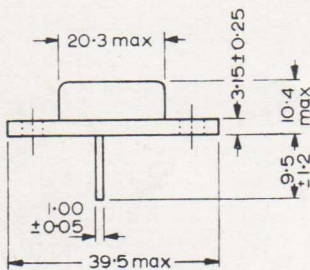

All dimensions in mm

MULLARD N-P-N TRANSISTORS

The OC139, OC140 and OC141 are the first n-p-n transistors to be introduced by Mullard. All three are germanium alloy junction types designed for high-speed computing circuits and other RF applications.

Among the many features of these new n-p-n transistors are:—

High Current Ratings of 250 mA peak and 200 mA average.

Low Bottoming Voltage of 220 mV max. at a collector current of 50 mA.

Low Leakage Current of 3 μ A max. (measured at 25°C.).

The maximum collector voltage is + 20V DC or peak, and maximum junction temperature is 75°C for continuous operation and 90°C for intermittent operation.

Each of the transistors OC139, OC140 and OC141 has nearly symmetrical emitter and collector junctions and is controlled for reverse current gain.

FOR HIGH SPEED COMPUTING

Two new RF germanium alloy transistors designed specifically for digital computing and other high-speed switching applications have been introduced by Mullard.

These new types, OC41 and OC42, carry full computing specifications with closely controlled characteristics. High peak currents are permissible, and turn-on turn-off times are specified. The OC41 and OC42 are intended to replace, in computing circuits, the currently-used OC44 and OC45, which were designed primarily for sine wave applications.

Both the new transistors are capable of passing a peak collector current of 125 mA, and have a leakage current, in grounded emitter connection, of 2 μ A (average) at an ambient temperature of 25°C. Collector bottoming voltage is 120 mV (average) at peak collector current.

The maximum junction temperature rating for continuous operation is 75°C.

AMATEUR EXPERIMENTERS COLUMN

72 Mc/s

TRANSISTOR OSCILLATOR

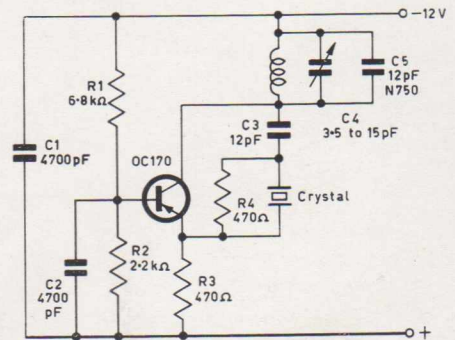

The above circuit features a Mullard OC170 alloy diffused junction transistor in a simple fifth overtone crystal oscillator circuit operating at a frequency of 72.2 Mc/s.

The self-capacitance of the crystal is shunted by a parallel connected 470 Ω carbon resistor and the tuned circuit consists of 4½ turns of 13 B & S silvered copper wire air wound to an inside diameter of ⅜ in. and spaced over a length of ½ in. The crystal is operated in the series resonant overtone mode and the tuned circuit is adjusted to resonance by a 3.5 to 15 pF ceramic trimmer.

CIRCULATION

Please circulate this copy of OUTLOOK and sign after reading.

<input type="checkbox"/>	<input type="checkbox"/>
<input type="checkbox"/>	<input type="checkbox"/>
<input type="checkbox"/>	<input type="checkbox"/>
<input type="checkbox"/>	<input type="checkbox"/>
<input type="checkbox"/>	<input type="checkbox"/>

Return copy to office for filing

MULLARD REPLACEMENTS FOR JAPANESE TRANSISTOR TYPES

Type No.	Application	+ Comparable Type	Type No.	Application	+ Comparable Type
HJ15	GP AF Amp.	OC71	2S32	GP AF Amp.	OC70
HJ17	GP AF Amp.	OC72	2S33	GP AF Amp.	OC72 OC74*
HJ17D	GP AF Amp.	OC71 OC72	2S34	GP AF Amp.	OC71 OC72
HJ22	IF Amp.	OC45	2S35	HF Converter	OC44
HJ22D	IF Amp.	OC45	2S36	IF Amp.	OC45
HJ23	HF Converter	OC44	2S37	GP AF Amp.	OC72
HJ23D	HF Converter	OC44	2S38	GP AF Amp.	OC72 OC74
HJ32	RF Amp.	OC44	2S39	GP LN AF Amp.	OC65
HJ34	GP AF Output	OC74	2S40	LP SW	OC76
HJ34A	GP AF Output	OC74	2S41	GP AF Power Amp.	OC16 OC26
HJ35	GP AF Power Amp.	OC16 OC26	2S42	GP AF Power Amp.	OC16 OC26
HJ50	GP AF Amp.	OC71	2S44	GP AF Amp.	OC70
HJ51	GP AF Amp.	OC71 OC72	2S45	RF Amp.	OC45
HJ52	IF Amp.	OC45	2S47	GP AF Amp.	OC70
HJ53	IF Amp.	OC45	2S49	IF Amp.	OC45
HJ54	IF Amp.	OC45	2S51	RF Amp.	OC44
HJ55	HF Converter	OC44	2S52	HF Converter	OC44
HJ56	IF Amp.	OC45	2S53	IF Amp.	OC45
HJ57	HF Converter	OC44	2S54	GP AF Amp.	OC72
HJ58	HF Converter	OC44	2S55	GP AF Amp.	OC72
HJ60	HF Converter	OC44	2S56	GP AF Amp.	OC72
HJ62	IF Amp.	OC45	2S62	RF Amp.	OC44
HJ63	HF Converter	OC44	2S63	RF Amp.	OC44
HJ70	RF Amp.	OC44	2S91	GP AF Output	OC74
ST5	GP AF Power Amp.	OC16 OC26	2S140	RF Amp.	OC44
ST37D	HF Converter	OC44	2S146	HF Converter	OC44
ST121	GP AF Amp.	OC71	2S148	IF Amp.	OC45
ST122	GP AF Amp.	OC72	2S149	HF Converter	OC44
ST163*	IF Amp.	OC45	2S184	GP AF Output	OC74
ST172*	HF Converter	OC44	2T15	GP AF Amp.	OC72
ST173*	HF Converter	OC44	2T16	GP AF Amp.	OC71
ST301	GP AF Amp.	OC71	2T64*	GP AF Amp.	OC73
ST302	GP AF Amp.	OC72	2T65*	GP AF Amp.	OC72
2NJ5A	IF Amp.	OC45	2T66*	GP AF Amp.	OC71 OC72
2NJ8A	HF Converter	OC44	2T73*	RF Amp.	OC45
2NJ9A	GP AF Amp.	OC72 OC74	2T76*	RF Amp.	OC45
2NJ9D	GP AF Amp.	OC70	2T78*	RF Amp.	OC45
2S12	HF Converter	OC44	2T85*	GP AF Amp.	OC72
2S13	IF Amp.	OC45	2T86*	GP AF Amp.	OC71
2S14	GP AF Amp.	OC71	2T501*	GP AF Power Amp.	OC16 OC26
2S18	GP AF Output	OC72 OC74	2T512*	HF Converter	OC44
2S24	GP AF Amp.	OC70	2T521*	IF Amp.	OC45
2S26	GP AF Power Amp.	OC16 OC26	2T522*	IF Amp.	OC45
2S30	HF Converter	OC44	2T523*	IF Amp.	OC45
2S31	IF Amp.	OC45	2T524*	IF Amp.	OC45

+ Comparable types are not direct equivalents but may be substituted in most applications. Maximum ratings should be observed.

* NPN Transistors — check polarity

Abbreviations

AF — Audio Frequency	HS — High Speed	LN — Low Noise	MP — Medium Power
DC — Direct Current	HV — High Voltage	LP — Low Power	MV — Medium Voltage
GP — General Purpose	IF — Intermediate Frequency	LS — Low Speed	RF — Radio Frequency
HF — High Frequency	LF — Low Frequency	LV — Low Voltage	SW — Switching
HI — High Current	LI — Low Current	MI — Medium Current	VHF — Very High Frequency



MULLARD-AUSTRALIA PTY. LTD., 35-43 CLARENCE ST., SYDNEY, BX 2006 & 123-129 VICTORIA PDE., COLLINGWOOD, N.5, VIC. 41 6644

Associated with MULLARD LIMITED, LONDON • MULLARD EQUIPMENT LIMITED • MULLARD OVERSEAS LIMITED

MVL-A 0860

