

*Oztra easy.*

The International Resistance Company's Monthly Bulletin Published in  
Furtherance of its Program of Helping Radio Service Men Do Better  
Work—and Make More Money Doing it . . . .

THE



# SERVICER

VOL. 1

NOVEMBER, 1933

NO. V

Buying cheap radio parts to save money is like turning back your  
clock to save time



..... SERVICE SAM

## SERVICE DOPE

Mention here of trouble on any particular make of equipment should not be construed as a reflection on the quality of those products. The best of radios will require attention from time to time. Thus, makes are mentioned only as a means of expediting prompt, efficient service on the wide variety of jobs confronting the average radio man. Readers are cordially invited to contribute their own service kinks to this department.

**F**RIEND Jim Barnes over at the Ye Radio Shoppe (wotta name!) was having trouble with a Philco which had evidently stood up under some pretty hard usage. Reception was intermittent, starting and stopping mysteriously. Sometimes all he needed to do was touch a part of the circuit with a screw driver to start the set operating again. I'd had this trouble before so tipped him off about checking the .01 mfd. coupling condensers which are usually located between successive stages of amplification on these sets. One side of the condenser is connected to the plate circuit and the other side to the grid circuit of the following tube. Jim thankfully followed my lead—and sure enough, that was where the trouble was found.

These condensers sometimes develop intermittent shorts or opens. The remedy is, of course, to replace 'em.

### Bosch Model 31

Fading in Bosch 31 Models, is occasionally caused by a defective 300,000 ohm resistance in the intermediate frequency stage.

### Put 'em on Ice!

R. R. Foster ("Ask Mr. Foster") of the Acme Radio Service Laboratory, Inc., Indianapolis, pops out with a time-saving idea regarding the testing of tubes.

"Occasionally a set will emit a decidedly annoying whoop or howl until it becomes heated. Naturally, suspicion points to the output tubes—especially the 45's or 47's but by the time we arrive on the

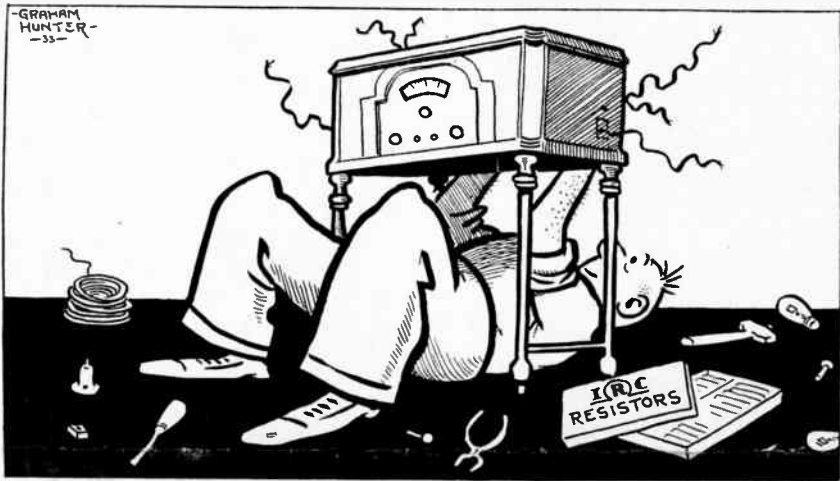

The ex-auto mechanic who took up radio servicing

job, the tubes are frequently heated and operating properly. Then we have to wait around until they cool in order to make an accurate test. Now, however, we always ask permission to place the tubes in the customer's refrigerator. This turns the trick in short order. We have used the method at least half a dozen times and it has never failed."

### Majestic 371

And here's one from J. H. Keith of Thor, Iowa:

"Called out on a Majestic 371," he writes. "I was told that it would choke up and stop after about 30 minutes. Sure enough it did. Tubes, voltage, alignment, etc., all checked, but I finally located the trouble in the speaker. Here the space between the field magnet and the voice coil was so small that, when the former got hot, it expanded against the voice coil and shut it off."

### An Auto Radio Hint

"I have been specializing," writes A. L. Hisson of Acme Radio Service, Rockford, Ill. "On auto radio for the past six months. One of the tips picked

up in connection with eliminating motor interference in GE 40 and RCA 40 sets is this: The triangular plate mounted on rubber to which the tuning control sheath is attached, should be grounded to the side of the set by a piece of flexible copper sheath. The cable sheath picks up interference and passes it to the tuning cable which is connected to the variable condenser rotors. I have cleaned up four installations this way."

### Majestic Model 20

A note in the July Servicer suggested heating the I. F. can (Majestic 20) and removing coil and condenser as a means of replacing the latter. Tom H. Brogan of the Radio Service Shop, Auburn, New York, suggests another method that he has been using for a long time. He writes: "Drill a 9/16" hole through side of the can toward the front of the set. This should be about an inch from the bottom and close to the side of the can on which the adjustment is mounted. This gives access to a bare wire that connects the .1 mfd. condenser to the ground. Cutting and tapping this wire cuts the condenser out of the circuit and  
(Concluded on page seven)

**READ F. L. SPRAYBERRY'S  
HELPFUL CONSTRUCTION  
ARTICLE ON PAGE THREE—**

## •• HOW to MAKE a CONDENSER TESTER ••

# DON'T BLAME the SET EVERY TIME! . . .

*These "Unusual Service" Call Stories Point to the Need for Constant Alertness in Checking Up on the "Little Things"*

ONE day not long ago, Serviceman Albert E. Hartwell of Aberdeen, Miss., was called to service an Atwater Kent Model 55 which, after two years of satisfactory operation, had developed loud "scratching noises".

\*When he arrived the set was operating perfectly but investigation showed that the antenna switch finger was loose. Thus, after tightening this and making a few minor adjustments, Serviceman Hartwell departed.

Two days later, however, the same trouble developed and he was called back. Once again, the set was playing perfectly and to make the trouble still more mystifying, everything checked out perfectly. Then it was that the lady of the house thought to mention that the "scratching noise" was noticeable only at night.

### A CLUE AT LAST

With this as a clue, Mr. Hartwell returned that evening only to listen to the radio give a perfect performance for an hour. This time when he left, he told the owner to call him as soon as the trouble developed. The call came only a few minutes after his return to the shop and, taking a small set with him, he hurried back.

Sure enough the "scratching noise" was unquestionably there—and it also appeared on the small set when this was hooked in. This, of course, sent Mr. Hartwell out on a check of the ground and antenna and here it was that the trouble was finally found—trouble which probably would not be found again in just this particular form in years of servicing.

The antenna led from a tree to the house with the lead-in coming down beside the driveway where the family sedan was invariably parked during the evenings. There was sufficient play in the lead-in to allow it to touch the drip moulding of the car which, in the course of time, had rubbed the insulation off the wire and grounded it to the extent of producing the annoying noise in the set. The trouble had not shown up earlier in the evening because the car had then been parked in the street.



There is nothing particularly startling about Mr. Hartwell's experience from a technical standpoint. However, it is more or less typical of dozens of other experiences related to the editors of the IRC Servicer and which serve as proof that

"gum shoe" work is sometimes almost as necessary as good servicing equipment and technical knowledge. The serviceman is, in a sense, a detective. As in all detective work, the smallest clues frequently turn out to be the most important. Not only must he be alert to grasp them but, equally important, he should be "on his toes" in bringing them to light. Frequently, a question may prove more helpful than hours of laborious testing—as, for instance, in the foregoing case. "Does the noise come at any particular time?"

### TURN ON THE LIGHTS!

\*Another case in point is cited by Al Fiess, an independent serviceman of Syracuse, N. Y. A local dealer had delivered three new Spartan sets to a woman who had returned them one after another as noisy and unsatisfactory. His own men had been unable to locate the cause of the complaint.

The set that was in the home when Al arrived worked perfectly. There was no hint of the trouble of which the woman complained. Finally, Al suggested turning on all of the lights in the house. This was done but without results. Then the lady remembered.



"Oh," she said. "There's one we've forgotten. My bedroom lamp."

She turned this on and the radio roared. "There," she exclaimed triumphantly. "That's the noise I mean."

"Yes," replied Al, "and as soon as I take that defective bulb out of the lamp and bounce it in the ash can, the noise will stop."

And it did. Simple wasn't it? Yet previous servicemen probably could have saved much time and effort by a few well directed questions as to just when the trouble cropped up and under what conditions.

### BEWARE OF PIPES THAT TOUCH

Mr. Fiess recounts another experience along somewhat similar lines. Here it is in his own words:

"This set was a powerful RCA without a.v.c. that was guilty of fluctuating volume. Several other servicemen had pronounced it Okay and I was about to do the same. The antenna was good and the ground was solidly fastened on a galvanized pipe.

"Well, we sat and waited for the set to kick up but without results—that is, until

the owner's wife who is of about the same build as Kate Smith started to walk around the room. Then things began to happen.

"I immediately rechecked the ground. It was solidly fastened to the galvanized pipe all right—but subsequent investigation showed that this was a gas pipe and that, at one spot, it rested lightly on a cold water pipe. When there was strain on the floor joists above the pipes occasionally parted company, thus accounting for the loss of volume."



Water, gas or drain pipes, intermittently touching the one to which a set is grounded are mentioned in a number of other letters wherein IRC enthusiasts describe unusually puzzling service calls. Defective light bulbs rate a close second. In practically every case, the real trouble was found only after extensive testing which, in several instances at least, might have been eliminated by a few well directed questions at the outset.

### TROUBLE IN THE KITCHEN

But you can, of course, seldom be sure. Many things may cause a radio to develop practically the same type of unsatisfactory reception. That is one of the fascinating—and, at times exasperating—features of the business. It is merely up to the serviceman to keep his wits about him at all times and to remember that, in some of the most puzzling cases, the set itself may not be at fault.

F. C. Mueller of Vale, Oregon, for instance, once found a kitchen garbage container at fault. Here the complaint referred to loud popping noises on a Victor RE 45 whenever the lady of the house was standing between the refrigerator and the electric range. A long search disclosed that the copper refrigeration pipes running to the compressor in the basement passed close enough to the metal garbage container so that the vibration from any one walking near by caused them to touch. The remedy consisted of nothing more than moving the container a few inches away from the pipe.

### ELIMINATING A HUM

Numerous other cases might be cited save for lack of space. Worth mentioning briefly, however, is a call cited by C. E. McCoy who, after considerable testing, cured an annoying hum in an Atwater Kent 42 simply by removing the coiled up excess of a. c. current supply cable which had been tucked into the back of the set where it lay on the chassis.

L. M. Brown of Grand Junction, Colorado found another severe case of oscillation resulting from proximity of the set to the wall. There were, he states, three circuits of electric wiring and a switch in the wall and these evidently set up a field of energy affecting the oscillation of the receiver. Mr. Brown likewise mentions a troublesome call where, after hours of searching, he located the diffi-

*(Continued on page six)*

## How to Make a Direct Reading

# BRIDGE CIRCUIT CONDENSER TESTER

By F. L. SPRAYBERRY

Radio Service Engineer

**P**RACTICALLY every experienced serviceman has, no doubt, frequently been in a position where he has wanted to test a condenser for capacity but where he has been without the means of doing so. Recently, however, a simple circuit has been developed in the writer's laboratory to fill this increasingly important need. With this, it is not only possible to test condensers for capacity, but also for shorts and opens. Electrolytics as well as condensers of other types can be handled quickly and conveniently. Moreover, all three tests may be made at the same time and while the condenser is in the receiving circuit providing there is nothing connected in parallel with it. Should another part be connected in parallel to the condenser, it is only necessary to disconnect one side to apply the test.

This new circuit (shown in Figure 1) is a standard balanced bridge circuit and is applicable for testing all large and small capacity values. The theory is to balance an a. c. voltage across a known capacity to where this voltage is the same as that across the condenser being tested. The balance is then obtained by rotating a dial until no sound is heard in the 'phone. When there is a balance, no a. c. current will flow through the 'phone and, of course, there will be no sound.

The circuit works as follows: The 110-volt a. c. line voltage of any frequency between 25 and 80 cycles is applied to the secondary side of a standard audio transformer of any ratio between 4 to 1 and 6 to 1. The reduced voltage from the other winding is connected to the outside terminals of a 20,000-ohm potentiometer. The voltage drop between the variable contact arm of the potentiometer and each outside terminal is then applied to a known capacity (by means of a switch) and an unknown capacity respectively. The voltage drop across any section of the

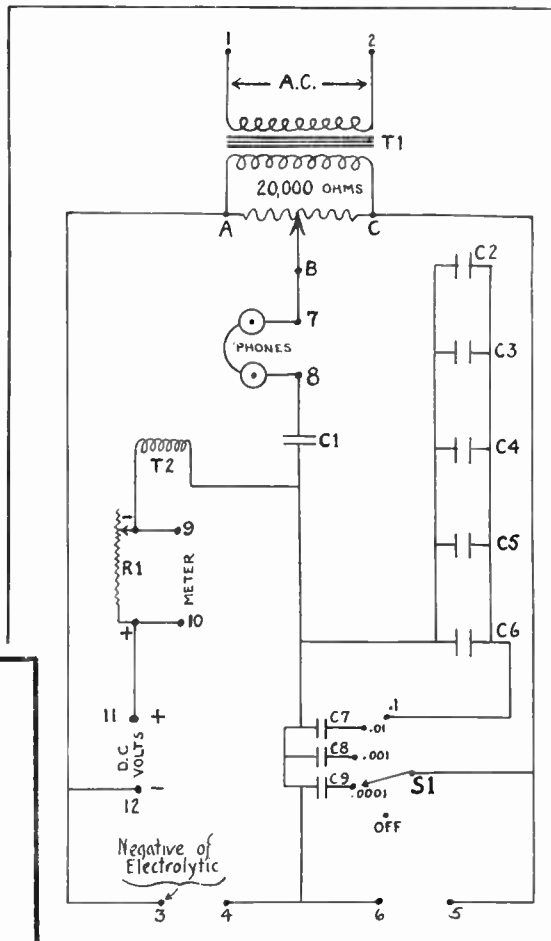

FIGURE 1

potentiometer can be made equal to the voltage drop across the condenser by adjusting the potentiometer knob until no sound is heard in the 'phone. The setting of the knob (or dial) will then be at a point on the dial (fig. 2) which will show the value of the unknown capacity.

The 20,000-ohm Yaxley potentiometer specified on the accompanying parts list comes equipped with a switch which, however, is not needed. The removal of a small screw according to the printed directions accompanying the potentiometer nullifies the effect of the switch. It is very important to use the exact potentiometer specified. Otherwise the scale (fig. 2) will not indicate accurately and the entire circuit will be valueless.

There is one precaution which should be observed in connecting the circuit. This is to be sure that terminal "A" on the potentiometer connects to terminal No. 3. Incidentally this will mean that

FIG. 2

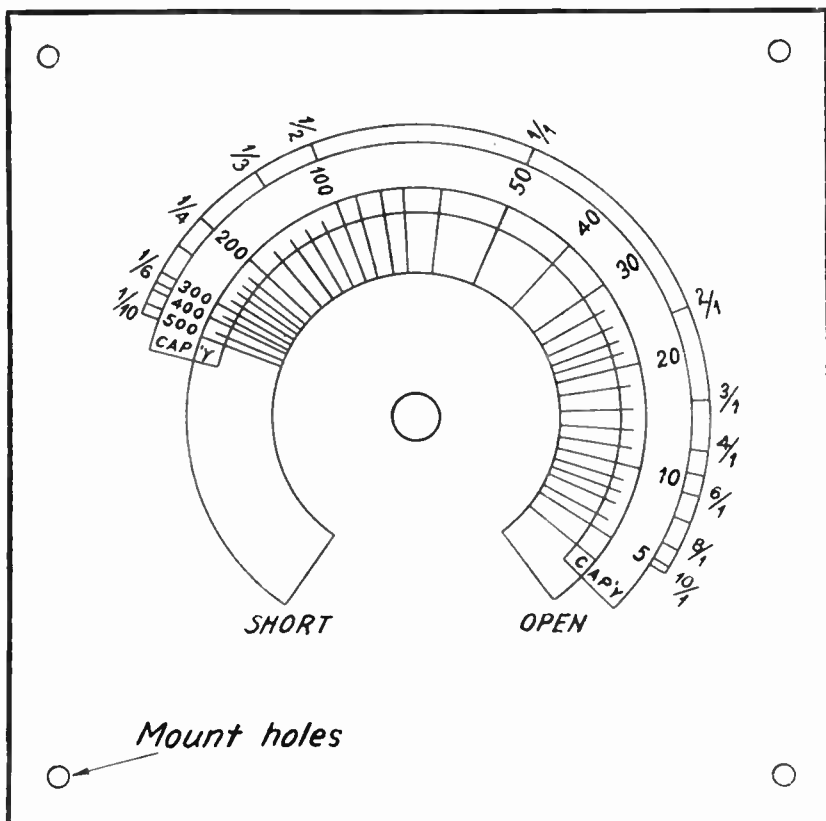

A HELPFUL CONSTRUCTION ARTICLE FEW SERVICEMEN WILL WANT TO MISS

(Continued from page three)  
terminal "C" must connect to terminal No. 5 and to the blade of S1.

**MOUNTING THE SCALE AND KNOB**

Any rheostat knob or volume control knob for a one-quarter inch shaft may be used with the potentiometer. A notch, scratch or other form of indicator point should be provided to serve as a reference mark. This will allow the scale to be read with reference to the position of the knob.

It is recommended that the scale (Fig. 2) be mounted on your panel in the following manner: Punch out the center one-quarter inch hole so it will fit over the shaft of the potentiometer. Obtain a sheet of isinglass or celluloid from a dealer handling automobile-top repair parts. This should be the same size or slightly larger than the scale of Fig. 2. Next, cut a hole in the center so that it fits over the potentiometer shaft. Then place the isinglass over the scale so that it may be protected from scratches, etc.

There is only one definite way in which the knob should be mounted. This is important. First, turn the shaft of the potentiometer all the way to the left, that is, counter-clockwise. Set the reference notch or mark of the knob exactly on "short" and tighten the set-screw so the knob will rotate the shaft. This done, rotate the knob all the way to the right, which should make the notch or pointer of the knob fall opposite the "open" position on the scale.

It is important to adjust both knob and scale so the pointer indicates the divisions of the scale accurately. For this reason it is recommended that final fastening of the scale to the panel with four screws should be the last step.

**USING THE DIRECT READING BRIDGE CIRCUIT**

The function of S1 is to connect known values of capacity across one arm of the bridge. While these capacities bear a definite relation to the unknown capacity, we do not use their actual values in determining the condition of an unknown unit. It is much easier and less confusing to use a simple multiplier value. This circuit has been so worked out that four multiplier values are employed. The first is .1, the second .01, the third .001 and the fourth .0001. (Note that these values do not represent capacity values—they are multiplier values only.) The position of S1 determines the multiplier value used. Therefore, it would be a good plan to mark the knob of S1 so that you will always know the value of the multiplier regardless of the position of the switch.

To use this device connect terminals 1 and 2 of Fig. 1 to the 110-volt a. c. line. Connect the 'phone to terminals 7 and 8. Connect the test leads to terminals 3 and 4. Then connect a .5 mfd. condenser to the leads. This will allow you to check the operation of the circuit.

Set S1 to the .1 multiple position. This will connect 5 mfd. of known capacity into the circuit, thus multiplying the scale by .1 (one-tenth). Rotate the knob until no signal is heard in the 'phone. The reference mark will be at approximately 5, proving that the actual capacity is .5, since the 5 on the scale is multiplied by .1 (one-tenth).

To check the .5 mfd. capacity further, set switch S1 to the .01 multiplier posi-

tion. This will connect .5 mfd. of known capacity into the circuit multiplying the scale by .01 (one-hundredth). Rotate the knob again until no signal is heard in the 'phone. The reference mark now will be at approximately 50, again proving that the actual capacity is .5, since the 50 on the scale is multiplied by .01.

Likewise, we can again check the .5 mfd. condenser by turning S1 to the .001 multiplier position. No signal will now be heard at approximately 500. As we multiply this by .0001, we move the decimal point over three places to the left, giving us .5 mfd. again for the capacity.

The "no signal" point can also be obtained at a position to the left of the 500 with S1 turned to the .0001 multiplier position. However, as this is off the scale it should be disregarded.

This same procedure is to be followed in determining the condition of practically any type of doubtful condenser. It is only necessary to connect the condenser to 3 and 4. Once the condenser is connected to 3 and 4 simply rotate the potentiometer knob for balance and read the value of the condenser on the scale of Fig. 2.

**TESTS WHICH PROVE OPENS AND SHORTS**

Condenser shorts and opens can easily be indicated with this circuit. To prove this, short-circuit terminals 3 and 4. No sound will now be heard when the knob is turned all the way to the left. To prove an open-circuit, remove both (or one) leads from terminals 3 and 4. Note that the no signal point will now occur with the knob turned all the way to the right. Both operations just described represent conditions of shorts and opens.

Leaky condensers may be detected by noting that a complete dying-out of the signal in the 'phone will not take place although there will be a minimum sound point on the dial. In order to understand what this means, try connecting a 1000-ohm resistance (or more) across terminals 3 and 4 while a good condenser under test also remains connected. The effect described above will be readily recognized.

**ELECTROLYTIC CONDENSER TESTS**

Electrolytic condensers are easily tested with this circuit. As before, the condenser to be tested is connected between terminals 3 and 4. Make certain that terminal 3 is connected to the negative lead (can) of the condenser. A high d. c. voltage source is connected between terminals 11 and 12, observing the polarity as shown in Fig. 1. If no high d. c. voltage from an a. c. power or B eliminator is available a single 45-volt battery may be used. A high-range milliammeter is now connected between 9 and 10. As a precaution, the 6 to 10-ohm rheostat should be turned all the way to the right so as to put a short circuit across 9 and 10. This is done to protect the meter in case of a complete short in the electrolytic condenser. The initial current is quite high and when operating current is developed, the rheostat can be turned to the off position, provided the condenser is not shorted. If there is a complete short, the condenser should be discarded.

A complete short will be evident after the condenser has been in the circuit a few minutes since the current will not reduce to less than 10 milliamperes. The leakage current through a normal electro-

lytic condenser should not be more than .25 milliamperes per microfarad of capacity, or not more than 2 ma. for an 8 mfd. condenser.

**PERCENTAGE OF ACCURACY**

In checking the capacity of one known capacity by four positions of S1 you will probably note that all readings will not agree exactly. This is to be expected because as most servicemen realize commercial condensers as well as numerous other parts are manufactured with a plus or minus tolerance of 10% from the specified value. This, of course, is more than ample for most jobs where a tolerance of twenty to fifty per cent from rated values can exist without materially decreasing efficiency. Therefore, in checking condensers, always consider all measurements as approximate.

The highest degree of accuracy is obtained when the "no sound" point on the potentiometer occurs near point 50 on the dial. Therefore, it is advisable to use the multiplier position of S1 that comes closest to making the "no sound" point occur near 50.

**SPECIAL DATA SHEETS AVAILABLE**

This condenser tester may also be used to test resistors and other small receiver parts for value, shorts and opens. It is also possible to test transformers for ratio between windings and to tell if windings are shorted or open. However, space here does not permit giving detailed directions for work of this kind. Thus, the International Resistance Company will gladly send complete data sheets for the tester including a special scale (Fig. 2). There is no charge for this service. Simply address International Resistance Company, 2100 Arch Street, Philadelphia, Pa.

**PARTS YOU WILL NEED FOR MAKING THE CONDENSER TESTER**

- 1—Panel 7" x 9".
- 12—Binding posts (Eby).
- 1—Yaxley #1615 Non-shorting 1-gang 5-point switch, (S1).
- 6—Sprague 1 mfd. condensers (C1, C2, C3, C4, C5 and C6).
- 1—Sprague .5 mfd. condenser (C7).
- 1— " .05 " " (C8).
- 1— " .005 " " (C9).
- 1—Yaxley #RP102—20,000-ohm potentiometer with A. C. switch.
- 1—6 or 10-ohm rheostat (R1).
- 1—A. F. transformer (any ratio between 4 to 1 and 6 to 1). (T1.)
- 1—30-henry choke (T2).
- 1—Set headphones with band.
- 1—Set test leads with clips.
- 1—Portable carrying case—8" x 14" (1 inch space for 'phones and leads).

**JOKE OF THE MONTH**

A service man had fallen off a ladder while putting up an aerial and cut his head.

"Sure," said the surgeon he hastily consulted, "I'll sew that up beautifully for only \$10."

"Gosh, doc," replied the S. M., "Can't you do it cheaper for just plain sewing. I don't want hemstitching and embroidery."

# Here it is!

Actual size illustration—  
note sturdy construction



## 5 SERVICE TOOLS IN ONE . . . . .

*New—Improved—Built to Last for Years*

**1** DUAL RESISTANCE  
INDICATOR

**2** CALIBRATED  
RHEOSTAT OR  
VARIABLE RESISTOR

**3** CALIBRATED  
POTENTIOMETER OR  
VOLTAGE DIVIDER

**4** MEASURING RESIST-  
ANCES BY SUB-  
STITUTION METHOD

**5** TEMPORARY  
STANDARD RESISTOR

Where 5% precision is satisfactory, Indicator may also be used in place of expensive resistor standards and decade boxes

—the NEW IRC Dual Resistance Indicator—just the piece of equipment servicemen have been asking for—designed and constructed the way they want it. Quickly tells the correct value for ANY resistor and has many other uses besides.

Two scales permit accurate readings from 100 to 100,000 ohms—improved ball bearing contact is spring-cushioned to prevent wear on wire—resistance rods are wound with heaviest wire and enclosed in strong metal case. Permanently attached slider insures smooth, uniform pressure and leaves user's hands free. Range of Indicator may be extended indefinitely by the addition of fixed resistors. Attractively packaged with complete, easy instructions for use in all of its many service applications.

*You'll Use it More Than  
Any Tool in Your Kit*

**\$2.70**

Net to Servicemen  
(List \$4.50)

→  
Use accompanying order blank. Mail either to us or to your IRC jobber. If sent to us, be sure and include jobber's name.

INTERNATIONAL RESISTANCE CO.,  
2100 Arch st., Philadelphia, Pa.

Enclosed find check or money order for \$2.85 (including 15¢ postage) for one of the NEW IRC Dual Resistance Indicators.

Name .....

Street .....

City .....

IRC Jobber .....

# IRC SERVICER

Published Monthly by  
INTERNATIONAL RESISTANCE CO.  
2100 Arch Street, Philadelphia, Pa.  
Toronto, Ont.

Ernest Searing.....*President*  
R. N. Shires.....*Secretary*  
Dan J. Fairbanks.....*Sales Manager*  
Harry A. Ehle...*Asst. to Sales Manager*

Harry Bridge, Jr., Editor  
F. L. Sprayberry, Contributing Editor

Copyright, 1933

No. V NOVEMBER, 1933 Vol. 1

## Business Improves

**A**LONG with many other lines of business, radio servicing has shown a substantial increase during the past few months. More than mere seasonal improvement, it is an indication that the New Deal is working—that things in general are definitely on the upgrade. Those who retain any doubt as to improvement have only to look back a year ago—or less—to note the vast forward strides which have been made. Then they will realize that it is doubt inspired by their own impatience and certainly not by facts.

Increased activity is evident throughout the radio industry—from manufacturers who report more orders than they can fill promptly, to servicemen who are finding the number of service calls to be considerably greater than might be expected as a result of seasonal influences. In any event, it is clear that radio is headed for a more profitable season than the trade has seen for years and it is up to each individual to put forth every effort in making the most of the opportunity.

So, now that the clouds of depression are slowly but surely clearing, let's "step on the gas". Let's contact old service customers—let's search out new ones. Let's do better service advertising—build better window displays. Let's check up on servicing equipment to make sure it is right—let's see that our stock of parts is both complete and of the highest grade. In short, as we suggested last month, "Let's make it a perpetual Rebuild Prosperity Campaign."

*It can be done!*

Page Six

## Don't Blame the Set

(Continued from page two)

culty in a defective lamp bulb, which hidden in a basement socket, was the last one in the house to be tested.

\*Last but not least is a puzzling job described by J. H. Farlow of Dover, Delaware. This had to do with a Philco which would play satisfactorily for a while before losing volume and finally cutting completely out. After five or ten minutes it would automatically come on again and repeat the performance. Here it was, however, that questions proved their worth. From the lady of the house, Mr. Farlow learned that her husband had lately installed a new floor receptacle in which the set was now connected. This was a clue and, following it, Mr. Farlow turned the trick on which other servicemen before him had failed.

A voltmeter cut into the receptacle showed that, after the set was turned on for a while, the voltage would drop. The next step was to check the receptacle itself. This proved to be a cheap, inferior product on which the contacts heated badly. Then, slowly but surely acting as a warp switch, they would open up until they became cool when contact would again be made.

**Send us the story of your unusual service calls. Each month writers of those judged most interesting from the editor's standpoint are awarded free kits of IRC Resistors. The right is, of course, reserved to publish any stories submitted whether they win kits or not.**

**Winners of this month's free kits are indicated by asterisks accompanying their experiences.**

\* \* \*

*Obtuse Oscar the office boy says it's all bunk about a broken mirror bringing seven years bad luck. His aunt broke one and nothing like that happened to her. She was killed in an auto accident the next day.*

## BRAIN TWISTER

175							175
							175
							175
							175
							175
							175
							175
175	175	175	175	175	175	175	175

**H**ERE'S one that should prove to be a real puzzler. There are 49 squares in the above block and the idea is to place a figure in each block so that added down, across or diagonally the total will be 175. Use the figures 1 to 49 inclusive. Only one figure is to be placed in each block and no figure is to be used more than once. Answer next month.

## Service Sam's Buddy Says:

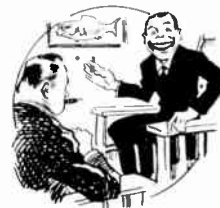

*There are thousands of ways of getting into trouble, but having service jobs done when they are promised isn't one of them.*

\* \* \*

"What's your name," asked the boss of the young fellow who had applied for a job.

"Ford," replied the latter. "Henry Ford."

"Henry Ford, eh?" remarked the manager with a smile. "That's a pretty well-known name."

"Well," replied the applicant proudly. "It ought to be. I've been servicing radios around here for two years."

\* \* \*

*Sam knows a colored man who is an exporter. He was just fired by the Pullman Company.*

\* \* \*

**Pete: "My girl had her nose broken in three places."**

**Repeat: "Gosh! That ought to teach her to keep out of those places."**

\* \* \*

*When you're wrong, admit it. Then the next time you're right more people will believe you.*

\* \* \*

Grandpa in a speedy car,  
Pushed the throttle down too far,  
Twinkle, twinkle little star,  
Music by the G. A. R.

\* \* \*

**Down East, they're telling about a serviceman who sent a big order to his jobber. Back came this telegram:**

**"Cannot ship order until you pay your past due bill."**

**"Can't wait that long," wired back the serviceman. "Cancel order."**

\* \* \*

"Central, how much does it cost to talk to Chicago?"

"Seventy-five cents for three minutes."

"Then how about giving me half rate for just listening? I want to call my wife."

\* \* \*

**Serviceman: "How about giving me the job?"**

**Radio Dealer: "All right. Come around in the morning. But I'm warning you—I'll only pay you what you're worth."**

**Serviceman: "Nothing doing. I'm getting more than that now."**

\* \* \*

A gentleman had sent for a serviceman to fix a radio in the bedroom. The maid had admitted the latter into the house and he was just starting upstairs when he met the owner and his wife coming down. Said the gentleman:

"Before you go upstairs, I want to acquaint you with the trouble."

The serviceman bowed politely to the lady and murmured:

"Pleased to meet you, madam."

## Service Dope

(Continued from page one)

it remains only to connect a new .1 mfd. condenser of 400 to 500 Volts rating from the red wire coming out of the can to the ground."

While reading Mr. Brogan's letter, we couldn't help but be favorably impressed with his letterhead—especially the lines which read:

**"Your Radio Entitles You to the Best of Uninterrupted Entertainment. If You are not getting it—PHONE 369"**

Not a bad way of stating it. Eh, what?

### Blame it on the Printers

Doggone the printers! Last month, in a perfectly good bit of Service Dope, the type-setter slipped one over on us. The result was that the article referred to "shortening of the .1 mfd. condenser."

"If its shortening you want," writes Serviceman C. B. Jeffries of Salem, Mo., "why not try Crisco or Mazola?" The answer is that we do—in our pie crust. However, we know Serviceman Jeffries was only kidding for his letter continues: "Seriously, I'm mighty glad to get the Servicer and want to compliment you on it—a good service help by a maker of good resistors!"

Thanx Mr. Jeffries. Have another slice of pie.

### Series K-20 Kolsters

Here's one from Serviceman J. W. Holden, of Salt Lake City, that ye editor has passed along thinking it may warrant notebook mention. It does. Mr. Holden writes: "On Kolsters of the series K-20, 21, 22, 23, 24, 25, 27 and 28 of which there are many still in use, it occasionally happens that a hard-to-find frying noise develops. If so, look at the grid leak mounting just behind the 227 tube and chances are your problem will be solved. A new grid leak is usually the remedy."

### Philco Model 96

One cause of cutting off or stopping of Philco 96 is a defective coupling condenser. This is connected between the plate of the detector amplifier tube and to one side of the volume control. Once or twice, I've found these condensers opening or shutting temporarily thus causing the trouble, but yesterday when I went on the assumption that this was what had happened to a set, I was wrong. This time it was the primary of the push-pull input transformer which had opened. I figured that, although the "open" might heal temporarily, the best thing to do was to replace the transformer and not run the risk of being bawled out by the customer if the trouble popped out again. At that, it took a lot of talking to convince him I wasn't trying to sell him something he really didn't need. Wurra-wurra! Such is the life of a serviceman!

**So much for this month—more next. Meanwhile, send in your own helpful service dope items from your notebook. Just address 'em to the Editor, IRC Servicer, 2100 Arch Street, Philadelphia, Pa.**

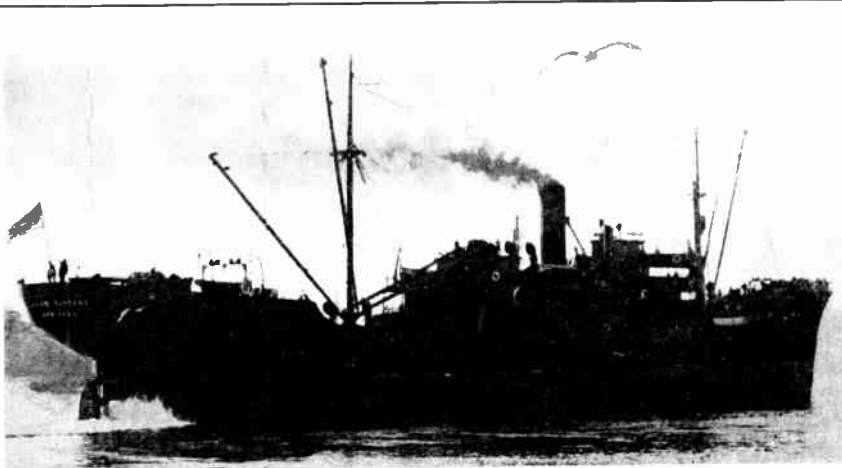

**AGAIN **IRC** RESISTORS  
GO TO THE ANTARCTIC  
WITH ADMIRAL BYRD**

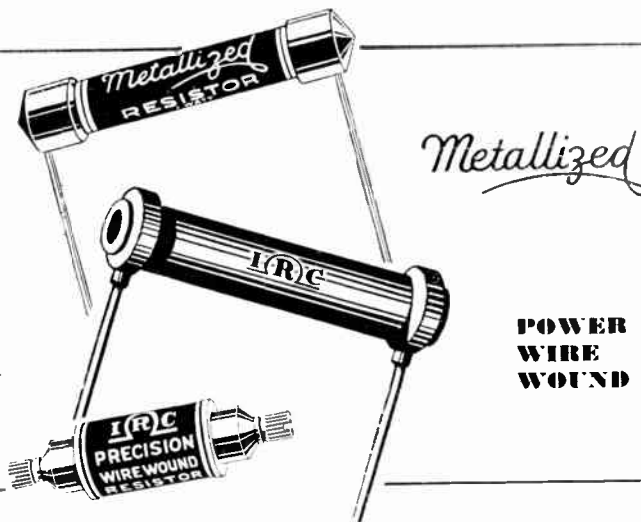

**PRECISION  
WIRE  
WOUND**

**POWER  
WIRE  
WOUND**

Hot weather—cold weather—ice—snow—intense humidity—dryness. All are encountered in rapid succession on an Antarctic expedition. All must be overcome. Radio transmitters and receivers must work perfectly at all times. Failure may mean disaster. When men stake their lives in frozen wastes, they cannot afford to take chances on inferior equipment. They first take pains to ascertain just which is best. Then they make sure that the best is what they get.

Standard IRC units are no strangers to the Antarctic ice fields. Used in the radio equipment on Admiral Byrd's first trip to Little America in 1928-30, they are now going back again. Tribute to their efficiency is expressed by Chief Radio Engineer Malcolm P. Hanson who wrote "... Our choice is prompted by the necessity of extreme dependability under adverse conditions and freedom from excessive tube noises which your resistors have shown in sensitive high frequency receivers."

*Insist on getting IRC's—the Industry's Standard*

**INTERNATIONAL RESISTANCE CO.,**

2100 Arch St., Philadelphia, Pa.

*In Canada, 74 Wellington St. W., Toronto, Ont.*

"SMILE AND THE WORLD SMILES WITH YOU—"



This smiling group comprises the radio parts sales staff of the Hickson Electric Company, popular IRC jobbers of Rochester, N. Y. Left to right, they are: "Jimmy" Harris, "Sully" Meade, Manager C. H. Drake, "Andy" Corning and "Hank" Worden. Every member of the Hickson staff is trained in practical radio work and servicemen who are "stuck" with difficult problems are invited to call on them for advice.

When the Hickson Electric Company went into the parts business several years ago, IRC was the first line selected for jobbing. Today, in accordance with the company's policy of featuring only high-grade, nationally known products, IRC resistors are still handled exclusively and have proved one of the most popular lines. Complete stocks of radio parts of all types are maintained at all times on the correct assumption that, when a serviceman asks for an item, he wants to get it PRONTO.

Praise from a Specialist

"About eighteen months ago," writes Earl R. Schuler who specializes on audio amplifiers 'way out in Prescott, Arizona, "you'll recall that I ordered sixteen Type K IRC Metallized Resistors in special values for use in a step-by-step grid gain control. This was installed in a small broadcasting station which could not afford a factory-built control of this type. The control is still in operation in front of a four-stage audio amplifier and is as quiet as it was the day it was installed. Best of all, it cost only \$5. I am so well pleased with this record that I am now going to make another control for a new system I am building. You'll receive the order for the resistors very shortly."

Repeat orders always speak for themselves but what manufacturer doesn't like to find an occasional word of praise accompanying them? While letters such as this one from Mr. Schuler are anything but uncommon here at IRC, we must confess that each new one still gives us a little thrill of satisfaction. Over and over again they prove what IRC has always contended, i.e., that quality parts sold on a quality basis are by far the best and most profitable for all concerned.

\* \* \*

Serviceman: "Well Jimmy, how do you like your new little sister?"

Jimmy: "Oh, she's all right. But we needed a new radio a lot worse."

SWAP or SELL SECTION

These classified advertisements are run free of charge for servicemen. The right is reserved to edit advertisements or eliminate any that are deemed unsuitable.

TRADE OR SELL—Readrite 245-A Test Kit; condenser blocks, parts, tubes, books and Monarch typewriter. Edward A. Turnier, c/o IRC Servicer.

FOR SALE—Atwater Kent, model 20 compact with tubes, speaker, and A and B eliminators. In good condition. Price \$6. H. E. Nicholls, c/o IRC Servicer.

WILL TRADE—Complete Hobart 8-hr. battery charger motor generator, 150 ampere capacity; battery molds and lead burning outfit. Will trade for Jannette Converter, 32 volts d.c. to 110 volts a.c., 60 cycles about 110 watts output. Also need Jewell set analyzer. What have you? Joe J. Youns, c/o IRC Servicer.

FOR SALE—1933 back numbers Short Wave Craft magazine, 10c plus 5c postage. George Bonin, c/o IRC Servicer.

WILL BUY—Will give cash or radio and service parts for old U. S. stamps. Look in your attic or old trunk—you may find some valuable stamps. Earling Nelson, c/o IRC Servicer.

FOR SALE—Esco 32/110 Volt a.c. Converter, 160 watt output, 60 cycle. In fine condition. \$25 cash, f.o.b. H. J. Krueger, c/o IRC Servicer.

WILL SWAP—Servicing instruments, parts and tubes as well as picture projectors for electrical appliances, auto accessories, etc. Eric W. Rosegren, c/o IRC Servicer.

TRADE OR SELL—Weston 8 1/2" d.c. Ammeter, model 57, 0 to 1.5 amperes; Weston 8 1/2" a.c. Ammeter, Model 151, 0 to 25 amperes; Readrite set analyzer Model 245 and Walker Short Wave Converter, Model 4X, 4-tube, 14 to 200 meters. All in good condition. Make offer. Need a late model tube tester or other service equipment. E. L. Seabeck, c/o IRC Servicer.

FOR SALE—Weston Model 660 Set Analyzer used but slightly. List price new \$75—will sell for \$47.75. Will sell Weston Model 533 tube checker with six adapters for \$18. Satullo Radio Sales & Service, c/o IRC Servicer.

FOR SALE—Large collection of U. S. commemorative postage stamps, also mixed lot of foreign. Write for list. Charles M. Conley, c/o IRC Servicer.

WILL TRADE—Signagraph for learning code—rolls, sending key, instructions, etc. included. Cost \$25. Need meters and service equipment or what have you? Robert L. Guttridge, c/o IRC Servicer.

WILL TRADE—Supreme Model 400-A Analyzer changed for testing all five prong tubes; also a Readrite 245-A tester. State what you have to offer or name your cash price. Theodore Mackintosh, c/o IRC Servicer.

WANTED—Silver Marshall S-M 225, 256, 223, 227, 257 and 272 a.f. transformers and S.M. 331 uni-choke. Have many parts to swap. R. W. Tanner, c/o IRC Servicer.

SWAP OR SELL—15 watt amplifier complete with tubes, turntable, pickup and speaker. Also a.c.-d.c. Generator, 150 watts, 110 volts, 60 cycles, 6 volts d.c. Was used only twice. Generator works with amplifier. What have you? Reynolds J. Castelli, c/o IRC Servicer.

WILL TRADE—15,000 meter Clapp-Eastham horizontal loose coupler in excellent condition. Original price \$48. What have you to offer? H. A. Merkel, c/o IRC Servicer.

WILL TRADE—Automatic Code Transmitter with three rolls of tape, a key and buzzer complete with instructions. Can use a set analyzer or meters. William Husarik, c/o IRC Servicer.

SWAP OR SELL—Sterling Mutual Conductance counter tube tester only slightly used. Will sell for \$25 or trade for good auto radio or short wave radio. Box S-1, c/o IRC Servicer.

WILL SELL OR TRADE—Jewell 209 Tube Tester with adapters for late tubes; Majestic Special Master B Eliminator and Readrite 501 Resistance meter. All in good condition. Orville Faulstich, c/o IRC Servicer.

Please Note!

If you do not receive the Servicer regularly, drop us a line on your regular service stationery. We'll gladly put your name on the mailing list. Or, if you have a friend in the service business whom you think will benefit through reading this little publication, either send his name along or suggest that he write to us direct.

To date, five copies of the Servicer have been issued—May, June, July, October and November. A few back copies of each issue are available and will gladly be sent to servicemen who request them.