



Electronic  
TUBE

# HAM NEWS

Copyright 1949, By General Electric Company

MAY—JUNE, 1949

VOL. 4—NO. 3



## FREQUENCY STANDARD

Continuous Coverage Interpolating Standard  
for Accurate Frequency Determinations

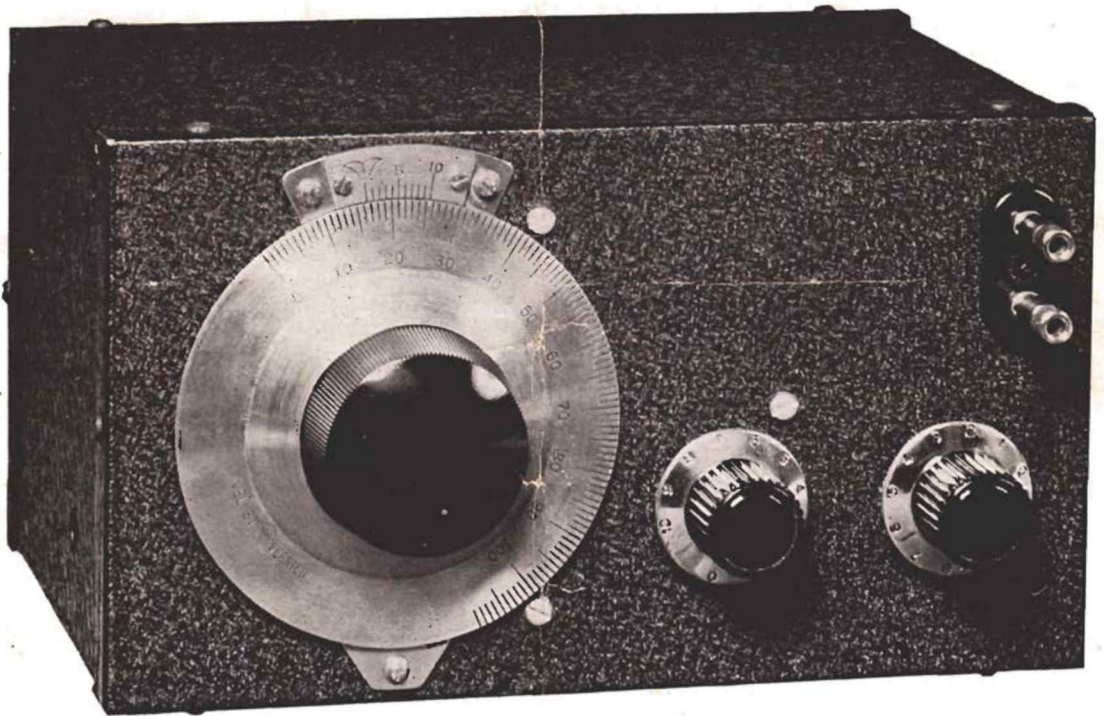

Fig. 1. Front View of the Frequency Standard. Main Tuning Dial on the Left, Blocking Oscillator Frequency Control in Middle, Output Control on the Right

### CONTENTS

Frequency Standard .....	pages 1-5
Questions and Answers (Glass to Metal Seals; C-R Tube Operation; Discoloring of Bulbs; Metal vs. Glass Tubes; V-R Tubes in Parallel) .....	pages 6-7
Tricks and Topics (Rotary Joint for Beams; Index Marking for Call Book) .....	page 7
Technical Data (6AK5) .....	page 8

## ELECTRICAL CIRCUIT

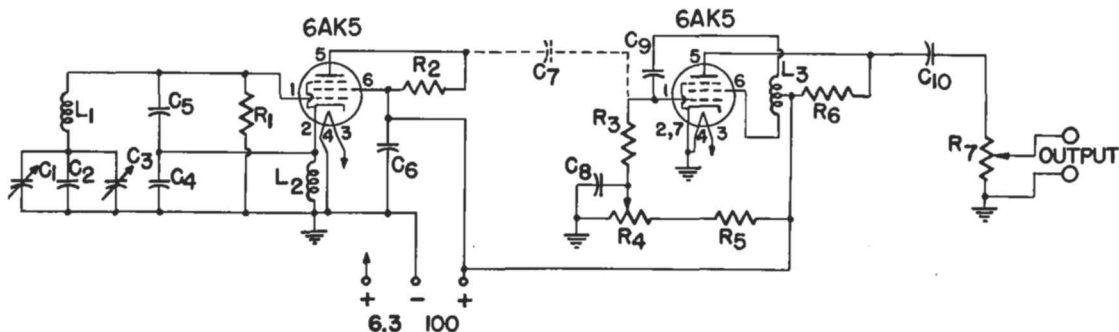

Fig. 2. Circuit Diagram of the Frequency Standard

### CIRCUIT CONSTANTS

<p>C<sub>1</sub>..... 12 mmf double-spaced variable (Millen #23915A with one stator plate removed)</p> <p>C<sub>2</sub>..... 270 mmf silver mica (250 plus 20)</p> <p>C<sub>3</sub>..... 50 mmf trimmer (Millen #26050)</p> <p>C<sub>4</sub>..... 0.01 mf mica</p> <p>C<sub>5</sub>..... 0.0047 mf mica</p> <p>C<sub>6</sub>..... 0.1 mf 200 volt paper</p> <p>C<sub>7</sub>..... Ceramic condenser, see text</p> <p>C<sub>8</sub>, C<sub>10</sub>..... 0.05 mf 200 volt paper</p> <p>C<sub>9</sub>..... 50 mmf ceramic</p> <p>L<sub>1</sub>, L<sub>2</sub>..... 8 millihenry air core inductance (Millen #34208)</p>	<p>L<sub>3</sub>..... 10 millihenry air core inductance with center tap (Millen #34210-1)</p> <p>R<sub>1</sub>, R<sub>6</sub>..... 0.1 meg, 1/2 watt</p> <p>R<sub>2</sub>..... 510 ohm, 1/2 watt</p> <p>R<sub>3</sub>..... 0.750 meg, 1/2 watt</p> <p>R<sub>4</sub>..... 10,000 ohm linear potentiometer</p> <p>R<sub>5</sub>..... 75,000 ohm 1/2 watt</p> <p>R<sub>7</sub>..... 100 ohm potentiometer</p> <p>Dial..... National Type N, scale 2</p> <p>Knobs..... National HRS-3 black</p> <p>Cabinet..... Parmetal UC596</p>
---	--

Frequency measuring work is done by every amateur each time he has a QSO. He may use his receiver, or a 100 kc crystal, or a calibrated VFO, or some other frequency measuring device. Whatever the method, he knows that the amateur he is working is in a certain band of frequencies, and similarly, he knows that he himself is transmitting in a certain band of frequencies. This is frequency measurement of a sort, although the percentage of accuracy is not good.

In an endeavour to increase the percentage of accuracy, many amateurs use 100 kc crystals, so that band edges can be spotted accurately. If this is done in conjunction with a receiver using adequate bandwidth, and with a nearly linear dial, it is possible to make frequency readings to within ten kilocycles or so.

In order to get accuracy beyond this point, it is usually necessary to go to so-called secondary frequency standards. The "secondary" refers to the fact that the standard is adjusted to some primary standard, such as WWV, so that the standard now becomes a second, or secondary standard. There are two general types of secondary frequency standards. One is the fixed frequency standard. This consists of a fixed frequency oscillator, usually using a crystal, and a means of generating sub-multiples of the fixed frequency. For example, a 100 kc crystal oscillator with or without a 10 kc multi-vibrator is such a standard.

The other type is the interpolating standard which is the type about to be described. The interpolating type differs from the fixed-frequency type in that the fundamental frequency of the former is variable. The standard shown in Fig. 1 has a fundamental frequency range which is variable from approximately 100 to 101 kilocycles. In addition, a frequency divider produces ten kilocycle frequency steps.

Therefore, if this standard were set at 100 kilocycles, the tenth harmonic could be heard on a re-

ceiver at 1000 kilocycles. At 1010 kc the first ten kc step could be heard. Now assume that a signal existed at 1005 kilocycles. By tuning, on the standard, until the standard's signal was zero beat with the 1005 kc signal, you would find that the dial had been moved just ninety degrees, so that the standard was now generating a signal at 100.5 kilocycles. Meanwhile, the ten kilocycle marker heard at 1010 kc would now be heard at 1015 kc. The exact use of this standard will be described later, but it can be seen that any unknown signal can be zeroed on by the standard, and the frequency accurately determined.

### ELECTRICAL DETAILS

Referring to the circuit diagram, Fig. 2, the 6AK5 on the left is the variable frequency oscillator. L<sub>1</sub> is the grid coil, C<sub>1</sub> the main tuning condenser, C<sub>2</sub> the fixed padding condenser, and C<sub>3</sub> the adjustable padding condenser, which enables the frequency to be set to exactly 100 kc when C<sub>1</sub> is set at zero on the dial. The circuit is a Clapp type of oscillator, which has become so popular recently because of its high order of stability.

The oscillator feeds into another 6AK5 tube which acts as a blocking oscillator. A blocking oscillator is used rather than a multi-vibrator because the blocking oscillator takes much less current (about 0.1 mil) and therefore contributes practically no heat to the unit. Potentiometer R<sub>4</sub> allows the frequency of oscillations to be varied, so that this stage may be set for ten kilocycles. The output from the frequency standard may be controlled by R<sub>7</sub>.

The circuit shown requires very little power to operate it. The high voltage requirements are 100 volts at approximately 10 mils, while the filament requirements are 6.3 volts at 0.350 amperes. This means that practically no heat is generated, so that temperature compensation was not necessary.

Because of the small power requirements, it is possible to supply plate and filament power from a

# ELECTRICAL CIRCUIT

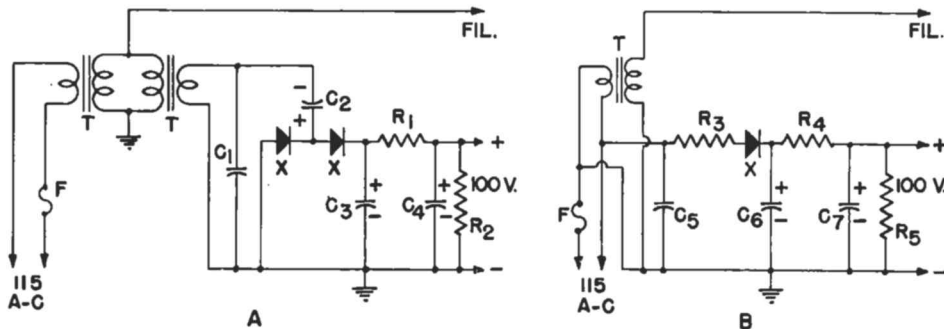

Fig. 3. Circuit Diagrams of Two Suggested Power Supplies

### CIRCUIT CONSTANTS

C <sub>1</sub> , C <sub>5</sub> .....	0.05 mf 600 volt paper
C <sub>2</sub> , C <sub>3</sub> , C <sub>6</sub> .....	40 mf 150 volt electrolytic
C <sub>4</sub> , C <sub>7</sub> .....	20 mf 150 volt electrolytic
F.....	1 ampere fuse
R <sub>1</sub> .....	.4700 ohm, 1/2 watt
R <sub>2</sub> .....	47,000 ohm, 1/2 watt

R <sub>3</sub> .....	50 ohm, 1/2 watt
R <sub>4</sub> .....	4000 ohm, 1/2 watt
R <sub>5</sub> .....	1 meg, 1/2 watt
T.....	6.3 volt, 1 ampere (Thordarson T-21F08)
X.....	Selenium rectifier (G-E 6RS5GH2)

receiver. In this case, the voltage used should be 100 volts, as specified, as the unit has been designed to operate at this approximate voltage only. A voltage regulator tube, such as the GL-OC3/VR-105, would make an excellent source of power, although a voltage regulated supply is not required.

Two suggested power supplies are shown in Fig. 3. The supply shown in Fig. 3A is a voltage doubler, which insures that 100 volts output will be obtained. Two filament transformers are used, back-to-back, to give a-c line isolation. The supply shown in Fig. 3B is a half-wave rectifier which operates directly from the a-c line. If this supply is used, care must be taken to see that proper a-c polarity is obtained when connecting the power supply to the line.

### MECHANICAL DETAILS

Fig. 1 shows the complete frequency standard in a 5 by 6 by 9 inch cabinet. The dial on the left is the main tuning control, the middle knob is R<sub>4</sub>, and the knob on the right is R<sub>7</sub>. The output is taken from the two terminals at the upper right.

An exposed view of the front panel, cabinet and power supply is shown in Fig. 5. The frequency standard proper is mounted on the front panel by means of a 3 by 4 by 5 inch box. The power supply is mounted on a 2 3/4 by 8 1/2 inch piece of 1/8 inch thick aluminum or steel, and fastened to the back panel of the cabinet by 3/4 inch metal bushings.

A rear view of the frequency standard proper is given in Fig. 4. In the right-hand portion of the 3 by 4 by 5 inch box will be seen the main tuning condenser (C<sub>1</sub>) with the padding condenser (C<sub>3</sub>) mounted below. The latter condenser is mounted on the side of the small box. It is adjusted through a hole cut in the cabinet (see Fig. 5). Directly above C<sub>1</sub> is L<sub>1</sub>, and to the right of L<sub>1</sub> will be seen C<sub>4</sub> and C<sub>5</sub>. These condensers are fastened to the box by a small metal strap. The slider from an adjustable resistor works very nicely for this.

The left-hand portion of the small box contains the two tube sockets and the remainder of the components, except for R<sub>7</sub> which is mounted directly to the front panel outside the box. The sketch of Fig. 6 shows how the various components are placed. Two components were deliberately left out of the sketch,

for the sake of clarity. C<sub>6</sub> should be connected to the B plus terminal of the four terminal strip and to pin 2 of the 6AK5 blocking oscillator tube. Condenser C<sub>7</sub> is connected from pin 5 of the VFO tube to pin 1 of the BO tube, if it is necessary. This will be explained later.

Figs. 7 and 8 give the layout details for the two suggested power supplies. Layout is not critical in any respect.

### CONSTRUCTIONAL DETAILS

Two of the parts specified may be critical, and on these parts no substitutions are recommended, unless the builder desires to do extra experimentation. These parts are L<sub>1</sub> and L<sub>3</sub>. Coil L<sub>1</sub> should have a moderately high Q in order for the 6AK5 oscillator to operate properly. The Millen #34208 coil has been found satisfactory. Coil L<sub>3</sub> is even more critical, as the proper operation of the blocking oscillator depends upon the proper coupling between the two halves of coil L<sub>3</sub>. The Millen #34210-1 coil will operate satisfactorily.

It is also strongly recommended that a National Type N dial (scale 2) be used for the main tuning dial. It is possible to read this dial accurately to one part in a thousand, for 180 degrees rotation. One division (out of a hundred) equals approximately ten cycles change in the variable frequency oscillator's frequency. The vernier permits reading to one-tenth of a division, which is a frequency change of one cycle. The stability of the Clapp oscillator more than justifies use of a dial which can be read to this accuracy.

The first step in the construction of the frequency standard is to mount the small box on the front panel of the cabinet. This is a job which requires checking with the tuning condenser used and the tuning dial so that the tuning dial is centered on the front panel and so that the tuning condenser mounts against the side of the small box. In general, the Type N dial will have its shaft center in from the left side of the cabinet approximately 2 5/8 inches. The vertical dimension will be one which centers the face of the dial on the front panel. The dial template will help in this layout.

When the hole for the dial is drilled, then the small box is mounted so that the tuning condenser can be held against the side of the box and mate

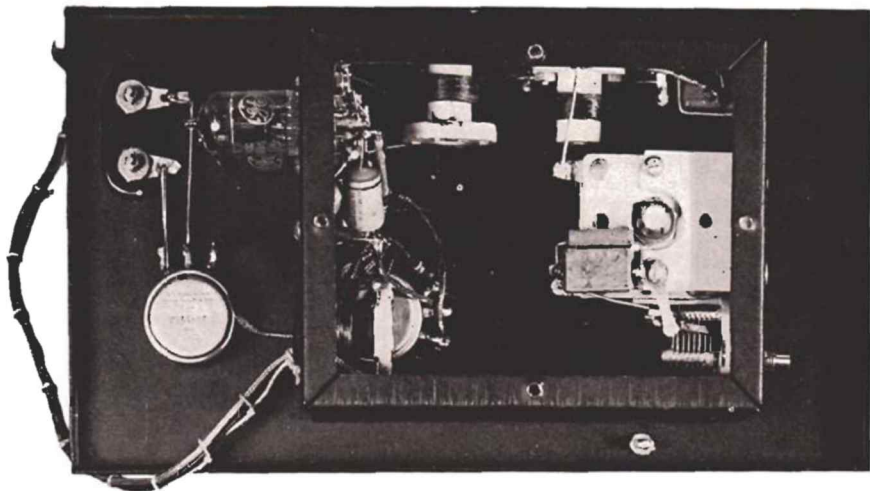

Fig. 4. Rear View of the Frequency Standard

with the tuning dial. It may be necessary to cut off part of the shaft on  $C_1$ . Fig. 4 gives the details of the bracket used to mount  $C_1$ . Two are used. The small box is centered vertically on the front panel, and is placed approximately  $1\frac{1}{2}$  inches from the edge of the cabinet in a horizontal direction.

Controls  $R_4$  and  $R_7$  are mounted  $1\frac{3}{4}$  inches up from the bottom of the panel and  $1\frac{3}{8}$  and  $3\frac{1}{2}$  inches respectively from the right hand edge of the panel.

The small box can now be removed from the front panel and the remainder of the parts mounted. Coil  $L_1$  should be mounted only by the two holes in the isolantite base. Spacers made of washers will hold the coil far enough off the chassis so that the connecting lugs do not touch the chassis. Do not put any machine screw through the center of the coil. Coils  $L_2$  and  $L_3$  may be mounted with machine screws through the center hole. Mount as shown in Fig. 4. The components in the box are then completely connected, except the connections to  $R_4$  and  $R_7$ . The small box is then mounted on the front panel and connections made to  $R_4$  and  $R_7$ .

It is recommended that the layout of parts as shown in Fig. 6 be followed closely. This layout is

efficient in its use of space, and gives sufficient isolation between the two stages. This is important.

#### TUNE-UP ADJUSTMENTS

Measure the d-c voltage applied to the unit and adjust until it is approximately 100 volts. If the power supply circuit in Fig. 3A is used, the voltage may be adjusted by increasing or decreasing  $R_1$ . The same thing is true of  $R_4$  in Fig. 3B.

Remove the 6AK5 blocking oscillator tube from its socket. Set the main dial to zero. Check the frequency of the variable oscillator by beating the 50th harmonic against WWV at 5,000 kc. Adjust to zero beat by means of  $C_3$ . The unit should have warmed up for about ten minutes before this is done. At this point it is desirable to check the operating level of the variable frequency oscillator. The d-c bias on pin 1 of the VFO tube should be between 3 and 4 volts as measured with a VTVM, or by means of a 20,000 ohm per volt voltmeter. In the latter case use the 10 volt scale and use a one megohm resistor at the end of the negative test lead where you connect to pin 1.

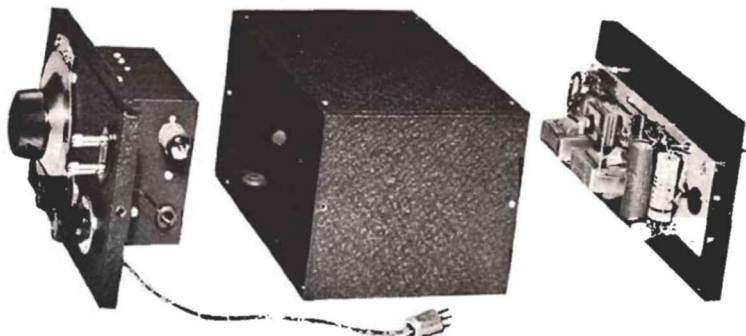

Fig. 5. Disassembled View of the Frequency Standard and Power Supply

If a sufficiently strong signal is not heard in the receiver, take the back off the 3 by 4 by 5 inch box and couple the receiver antenna to the oscillator by bringing a lead close to the plate circuit.

The next step is to determine the exact frequency change incurred when the main tuning dial is tuned through 180 degrees. This may be done several ways. The easiest method is to tune in WWV at 10,000 kc. The 100th harmonic of the oscillator should be heard at zero beat with WWV. Now tune the dial until zero beat is again heard. This will be with the dial tuned through approximately 150 degrees, if the circuit constants have been followed carefully. As the dial is tuned the frequency increases. When the frequency is exactly 101.01 kc the 99th harmonic is at zero beat with WWV at 10,000 kc. By noting the dial reading and taking the ratio between it and full scale, the exact frequency range of the dial can be determined.

For the purpose of further explanation, let us assume that the dial was found to cover 100 to 101.250 kilocycles when going from zero through 100 divisions. This means that each division of the 100 divisions on the dial represents a change of 12.50 cycles. The dial readings will be linear because of the relatively small frequency range covered.

Now put the 6AK5 tube in the blocking oscillator socket after carefully cleaning each tube pin with fine steel wool. This may be an unnecessary precaution, but a form of microphonism may occur if this is not done. Condenser  $C_7$  should not be wired in at this time.

Set  $C_1$  to zero and tune in the signal on a relatively low frequency. Turn the receiver BFO on. Tune the receiver slowly. There should be a beat each ten kilocycles when  $R_4$  is properly adjusted. Listen on the even 100 kc points as you adjust  $R_4$ . The frequency will be found to lock into place. If this is not true, add  $C_7$  to the circuit. Try 5 mmf. Experiment until beats are heard regularly and clearly. Once  $C_7$  is the proper value (more than 10 mmf should not be necessary, and it is possible that  $C_7$  may be omitted entirely) double check to determine if the blocking oscillator is producing 10 kc steps. If not, it may be necessary to change the value of either  $R_3$  or  $R_5$ . Both 9 kc and 11 kc steps may be found by adjusting  $R_4$ . Once 10 kc steps are heard in the receiver, the unit is ready for use.

#### USE OF THE FREQUENCY STANDARD

The proper use of this frequency standard can best be explained by means of an example. One factor must always be kept in mind, and that is the number of cycles (at the fundamental frequency) that is represented by one division of the main tuning dial. We shall assume, for this discussion, that this factor is 12.50 cycles per division.

Next assume that you wish to measure the frequency of a signal which is somewhere between 3990

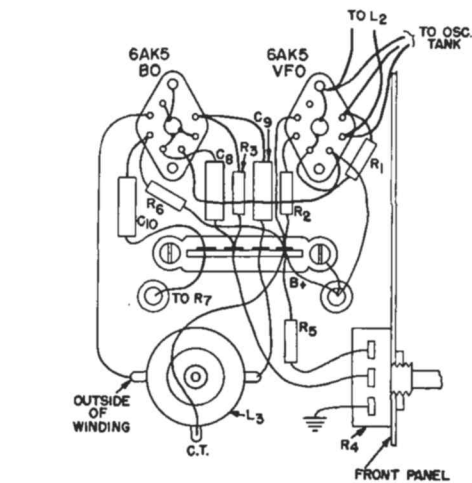

Fig. 6. Sketch Showing Component Layout

and 4000 kilocycles. This assumes that you have previously calibrated your receiver with the frequency standard so that you know the dial readings for 3990 and 4000 kilocycles. Now, with the frequency standard set at zero, the 39.9th harmonic of the fundamental frequency is below the unknown. By tuning the main dial on the frequency standard this 39.9th harmonic can be increased in frequency until it gives zero beat with the unknown.

Assume the dial reading, when zero beat is obtained, is 7.0 divisions (out of 100). We have therefore moved the fundamental frequency 7.0 times 12.50 or 87.5 cycles. Therefore, the unknown frequency is 87.5 times 39.9 or 3,491.25 cycles above 3990 kc. The actual frequency of the unknown is therefore 3,990.00 plus 3,491.25 or 3993.491 kilocycles. As a double check, we can keep tuning the main dial on the frequency standard until the 39.8 harmonic moves up to zero beat with the unknown.

The second reading may be, for example, 27.1 divisions. This is a change of 12.50 times 27.1 or 338.75 cycles. This times 39.8 is 13,482.25 cycles. This added to 3980.00 is 3993.482 kilocycles. This figure is 9 cycles off from the first. The two readings may be averaged for a final reading.

It will be seen from the above that the reading accuracy is about 40 cycles at 4 megacycles, or 10 parts per million. This is the so-called short term accuracy, based on checks against WWV every hour or so. The long time accuracy will depend on how well the unit is constructed, the ambient temperature conditions, and the effective temperature coefficient of the components used.

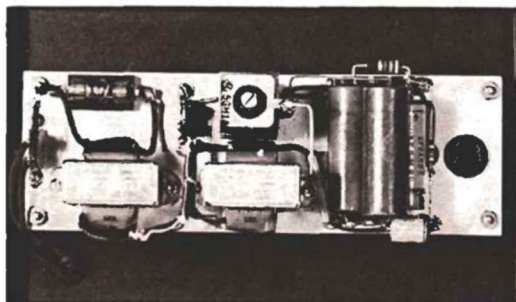

Fig. 7. Power Supply (Fig. 3A)

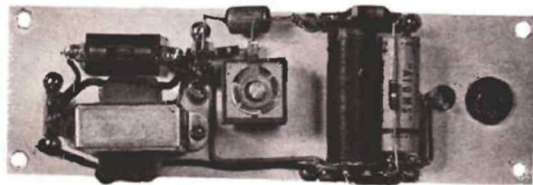

Fig. 8. Power Supply (Fig. 3B)

# QUESTIONS AND ANSWERS



Do you have any questions about tubes or tube circuits that are of general interest? For each question published you will receive \$10 worth of G-E Electronic tubes. Mark your letter "Entry for Questions and Answers" and send to Lighthouse Larry, Tube Division, Bldg. 269, General Electric Company, Schenectady, New York, or in Canada to Canadian General Electric Company, Ltd., Toronto, Ontario.

## GLASS TO METAL SEALS

**Question:** How is the glass to metal seal accomplished in miniature tubes?—J. L. Stafford.

**Answer:** The glass envelope of a miniature tube (either the 7- or 9-pin type) is formed from two pieces, a glass bulb and a glass stem. These pieces are joined near the point where the metal leads come through the stem. This sealing operation is the last bit of assembly work done prior to exhaust.

The glass stem is a flat button of glass with the metal pins, or leads, going through the glass and being sealed to it. The leads are usually several pieces of metal welded end to end. For example, a lead may consist of a piece of nickel (which serves as the pin) welded to a piece of dumet, which is welded to a second piece of nickel. The second piece of nickel is inside the bulb and connects to the tube elements.

The glass in the button base is sealed to the dumet portion of the lead by the application of heat to both the glass and the lead. An airtight seal is made possible, despite differential expansion of the lead and the glass, due to the way dumet is made. Basically, dumet is a piece of copper-clad iron. The glass adheres to the thin copper sheath. As changes in temperature cause the glass to expand and contract, the thin copper sheath is able to follow this movement without causing an air leak.

Manufacturing a miniature tube therefore follows this pattern. The glass stem is made by sealing seven (or nine) leads into a glass button. The tube elements are mounted on the leads. The glass bulb is slipped over the elements and sealed to the glass stem.—Lighthouse Larry.

## C-R TUBE OPERATION

**Question:** With tubes such as the 5BP1, 3AP1, etc., the cathode is connected to one side of the filament internally, making it necessary to use a filament transformer which is insulated to stand the voltage on the cathode, which may be a thousand volts or more. However, tubes such as the 5CP1, 3KP1, etc., have a separate cathode lead brought out on a separate pin. In this case can one side of the filament be grounded, so that an inexpensive transformer may be used? Also, will the phosphor of cathode-ray tubes

lose its fluorescent properties, or otherwise deteriorate, if the tubes are stored for a period of four or five years without use?—W4NZY.

**Answer:** In the case of cathode-ray tubes where the cathode is not connected to the filament internally, it is recommended that the cathode be connected to the center-tap or one side of the filament winding. This means that a well-insulated transformer is required. In the event that this connection is not made, these tubes are rated to have no more than 140 volts between the cathode connection and either of the two filament leads.

There should be no deterioration taking place in a cathode-ray tube stored as you state.—Lighthouse Larry.

## DISCOLORING OF BULBS

**Question:** What causes the silver color on the glass bulbs of high vacuum rectifiers such as the 25ZG-GT and the 35Z5-GT after they have been used for several months?—R. Wagner.

**Answer:** This effect will be noted in many types of tubes. The silver color is caused by a very thin deposit of metal. The metal may be aluminum, magnesium, nickel, etc., or a combination of metals, depending on the type of tube involved.

Almost any type of metal, when evaporated and deposited in a thin layer on the inside of a vacuum tube, will appear as a silvery or mirror-like finish. The same effect causes the silver color of the getter material which is deposited on the inside of the bulb at the time of manufacture.—Lighthouse Larry.

## METAL VS. GLASS TUBES

**Question:** Are there any general rules that can be made as to the selection of metal tubes over glass tubes, or vice versa, as to radiation of heat, shielding, microphonics, maximum usable frequency, etc.?—H. Van Valkenburgh.

**Answer:** It is assumed in this question that the term glass tubes refers to the large-size tubes, and not to miniature tubes. In this case, no general rules can be given, but a discussion of relative merits might be in order.

A metal tube will certainly radiate more heat from its metal shell than a glass tube will from its glass envelope. However, the glass bulb permits the loss of radiant heat energy through the glass bulb, so that a metal tube shell must, of necessity, be capable of radiating more heat. There cannot be too much difference in the total heat-releasing capabilities of glass vs. metal, as similar types of tubes are given the same rating.

Metal tubes are superior from the shielding standpoint. Even though a glass tube uses an external metal shield, this shield is liable to cause circuit noise.

There is no comparison of glass vs. metal that can be made concerning the maximum usable frequency, as this ties in with the tube type under con-

sideration. The same general statement also holds true for microphonics, as this depends to a large degree on the internal construction.

As a last point, the metal tube may be considered sturdier. The metal shell is less liable to be damaged, by a glancing blow from a screwdriver, for example, than a glass bulb.—Lighthouse Larry.

#### V-R TUBES IN PARALLEL

**Question:** When using voltage regulator tubes in parallel, what method can be used to obtain an equal current flow through each tube?—W4LTV.

**Answer:** Voltage regulator tubes are not recommended for parallel operation because no satisfactory

method has yet been found to balance the tubes properly. If series resistance is used, then the regulating properties of the tube are lost. However, even if this were to be done, the problem of starting voltage is still present. If one tube requires an appreciably higher starting voltage than the other, the first tube will not even be ignited.—Lighthouse Larry.



## TRICKS AND TOPICS

How did you solve that last problem that almost had you stumped? Be it about tubes, antennas, circuits, etc., Lighthouse Larry would like to tell the rest of the hams about it. Send it in! For each "trick" published you win \$10 worth of G-E Electronic Tubes. No entries returned. Mark your letter "Entry for Tricks and Topics" and send to Lighthouse Larry, Tube Division, Bldg. 269, General Electric Company, Schenectady, New York, or in Canada, to Canadian General Electric Company, Ltd., Toronto Ontario.

#### ROTARY JOINT FOR BEAMS

Recently, when I got the urge to put up a ten meter beam, I was faced with the usual problem of providing 360 degree rotation without winding the feed line into a twisted mess. Fig. 9 shows how this problem was overcome. Because these types of coaxial connectors are readily available at low prices at the present time, the over-all arrangement is inexpensive and yet very satisfactory in performance.

The 83-1R connector is bolted to the pipe flange and the latter is fastened securely to the pipe after connecting the coaxial cable to the 83-1R connector. The flange and the 83-1R connector are then free to turn as the beam turns, while the elbow and the 83-1SP connector are stationary.

After assembly the collar of the 83-1AP elbow may be soldered to the 83-1R connector to prevent the collar from loosening, and to make a better electrical connection.

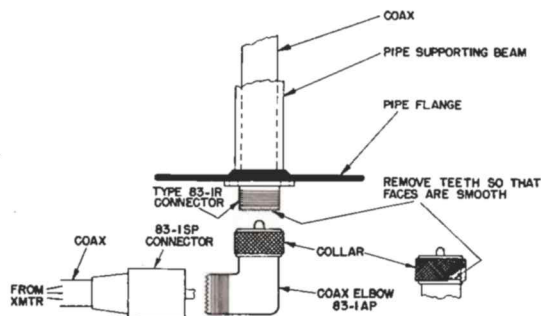

Fig. 9. Rotary Joint for Beam

There may be an impedance discontinuity present at the rotary joint, but it should be less than in other types of rotary joints. At any rate, it has been in use for over a year, has given no trouble, and I have worked over fifty countries with the beam.—W4INO.

(Ed's note: This arrangement is probably not completely waterproof. A covering of some sort is therefore advisable.)

#### INDEX MARKING FOR CALL BOOK

A very easy way to make a set of thumb index marks for your call book without cutting or pasting on cumbersome tabs is described below. This may not be original but the writer discovered this simple and effective method. All that is needed is a bottle of black ink (preferably india ink) and a pen.

Open the call book to the first district. On the right edge of the right page make a mark  $\frac{1}{8}$  in. wide and  $\frac{3}{8}$  in. long, starting about  $\frac{3}{4}$  in. from the top of the page (Fig. 10). Then open the call book to the second district and make a similar mark, starting about  $\frac{1}{8}$  in. below the bottom of the mark of the first call area (as shown at "b"). Follow this sequence through the book for each call area and each major foreign country, including any of your favorite DX areas, ending with the Q signals.

After this is done, fold the book so that the cut edges fan out about 2 in. wide. The black marks can then be easily seen. In front of each of the marks print the corresponding number of the call area or the foreign prefix.—W2FEN.

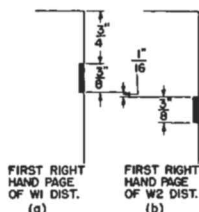
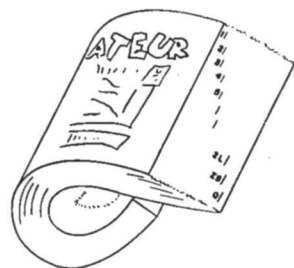

Fig. 10. Call Book Index Marking



# TECHNICAL INFORMATION

## 6AK5

### GENERAL DESCRIPTION

**Principal Application:** The 6AK5 is a miniature radio-frequency amplifier pentode with sharp cut-off characteristics. Its high transconductance combined with low interelectrode capacitances and the short

lead lengths obtained as a result of its miniature construction enable this tube to be used effectively as a radio-frequency amplifier at frequencies up to approximately 400 megacycles.

Cathode	Coated Unipotential
Heater Voltage (A-C or D-C)	6.3 Volts
Heater Current	0.175 Ampere
Envelope	T-5½ Glass
Base	E7-1 Miniature Button 7-pin

Mounting Position	Any
Direct Interelectrode Capacitances*	
Grid to Plate (Max)	0.02 μf
Input	4.0 μf
Output	2.8 μf

### MAXIMUM RATINGS

#### DESIGN-CENTER VALUES:

Plate Voltage	180	Volts
Screen Voltage	140	Volts
Peak Heater-Cathode Potential	90	Volts
Plate Dissipation	1.7	Watts
Screen Dissipation	0.5	Watts
Cathode Current	18	Milliamperes

### CHARACTERISTICS AND TYPICAL OPERATION

Plate Voltage	120	150	180	Volts
Screen Voltage	120	140	120	Volts
Cathode-Bias Resistor**	200	330	200	Ohms
Plate Resistance (Approximate)	0.34	0.42	0.69	Megohms
Transconductance	5000	4300	5100	Micromhos
Plate Current	7.5	7.0	7.7	Milliamperes
Screen Current	2.5	2.2	2.4	Milliamperes

\* With RMA standard shield No. 316 connected to cathode.

\*\*Fixed-biased operation is not recommended.

### BASING DIAGRAM



RMA 7BD  
BOTTOM VIEW

### TERMINAL CONNECTIONS

- Pin 1—Grid Number 1
- Pin 2—Cathode, Internal Shield, Grid No. 3
- Pin 3—Heater
- Pin 4—Heater
- Pin 5—Plate
- Pin 6—Grid No. 2
- Pin 7—Cathode, Internal Shield, Grid No. 3

ELECTRONICS DEPARTMENT

**GENERAL ELECTRIC**

SCHENECTADY, N. Y.

(In Canada, Canadian General Electric Company, Ltd., Toronto, Ont.)