

the GENERAL RADIO Experimenter



©1956 • GENERAL RADIO Company, Cambridge, Mass., U. S. A.

Since 1915 — Manufacturers of Electronic Apparatus for Science and Industry

VOLUME 30 No. 9

FEBRUARY, 1956

THE MEASUREMENT OF IMPACT NOISE

Many of the everyday noises that we hear are impact noises. They range in intensity from the "tick-tock" of a watch to the tremendous crash of a huge drop hammer. In the industrial plant impact noises are produced by hammers, riveters, chippers, and punch presses; and in the office, by typewriters and business machines of various sorts. A related class of noise is explosive noise as in gun fire or even the repeated explosions of gasoline engines in autos and trucks. To industry, some of these noises can be a serious problem, particularly those produced by large drop hammers, because of the possible hearing loss that can result from con-

tinued exposure to the noise.¹ This problem has led to considerable research in the fields of hearing damage from noise, of noise reduction, and of noise measurement.

Noise measurements with sound-level meters and spectrum analyzers are inadequate for evaluating impact noise. A cathode-ray oscillograph can be used to study this type of noise, but the measurement is so complicated that it is performed mainly in the research laboratory.

A new instrument, the TYPE 1556-A

¹ Subcommittee Z24-X-2, "The Relation of Hearing Loss to Noise Exposure," American Standards Association, New York, 1954, p. 49.

Figure 1 (left). Oscillogram of noise from a single strike of a punch press doing a simple forming operation. The time scale along the horizontal axis is 10 milliseconds per division. The instantaneous sound pressure is displayed on the vertical axis, and the peak level recorded is 120 db re 0.002 microbar.

Figure 2 (center). Oscillograms of noise from two separate handclaps. The time scale along the horizontal axis is 2 milliseconds per division.

Figure 3 (right). Oscillogram of noise from a small drop hammer. The time scale along the horizontal axis is 10 milliseconds per scale division.

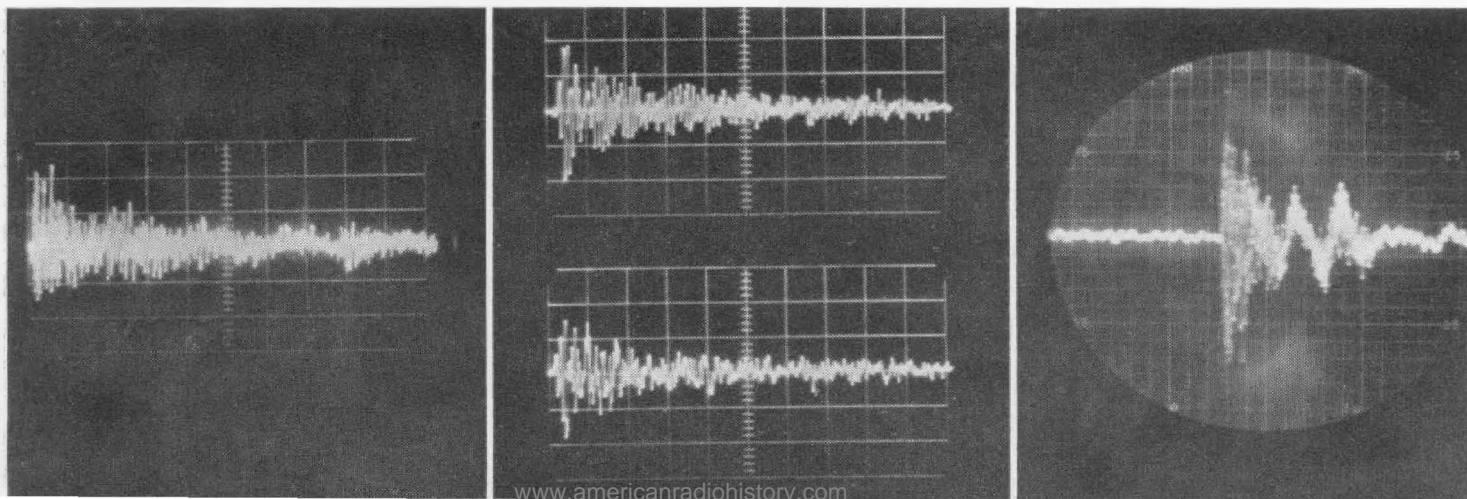

Impact Noise Analyzer, shown in Figure 4, has been recently developed to simplify these measurements. This instrument is an accessory for a sound-level meter, and it can be used to measure certain significant characteristics of an impact noise. It is also useful as an accessory for spectrum analyzers, such as the TYPE 1550-A Octave Band Noise Analyzer, for magnetic tape recorders and for the TYPE 761-A Vibration Meter.

The considerations underlying the design, operation, and application of this new instrument will be better understood if we consider first some of the characteristics of impact noises.

Characteristics of Impact Noise

Figures 1, 2, and 3 are oscillographic records of instantaneous sound pressure (the vertical ordinate) versus time (horizontal axis). Figure 1 is the oscillogram of the electrical output of a condenser microphone placed 4 feet from a punch press doing a simple forming operation. The time scale along the horizontal axis is 10 milliseconds per division, that is, 0.1 second for the full sweep. The instantaneous peak level shown in the oscillogram is 120 db (*re* 0.0002 microbar) and occurs about 5 milliseconds after the first sound from the impact. At 1 millisecond, a level of about 119 db is reached. After this initial rapid rise, the level decays, so that after about 30 milliseconds it is appreciably below its maximum. One interesting feature of this impact sound is the random nature of the individual peak amplitudes. That is, although there is the general trend of a rapid rise to a maximum value and a slower but still rapid decay, successive peak amplitudes vary appreciably. This behavior

is shown more clearly in succeeding oscillograms. The sound-pressure wave is also dissymmetrical, with the positive, or excess, pressure wave having the highest instantaneous peak level.

The oscillograms in Figure 2 correspond to the sound pressure waves of two separate handclaps about 18 inches from the condenser microphone. Here the time scale has been spread out, each division being 2 milliseconds. The instantaneous peak positive levels, attained in a fraction of a millisecond, are 117 db and 115 db, and the negative levels are 118 db and 117 db. The decay is appreciably longer, being several milliseconds. The dissymmetry here is not marked, but the randomness of the individual amplitudes of the oscillations is clearly shown.

The oscillogram* of Figure 3 is a

*Courtesy of Liberty Mutual Insurance Company, Boston, Massachusetts.

Figure 4. View of Impact Noise Analyzer attached to a sound-level meter.

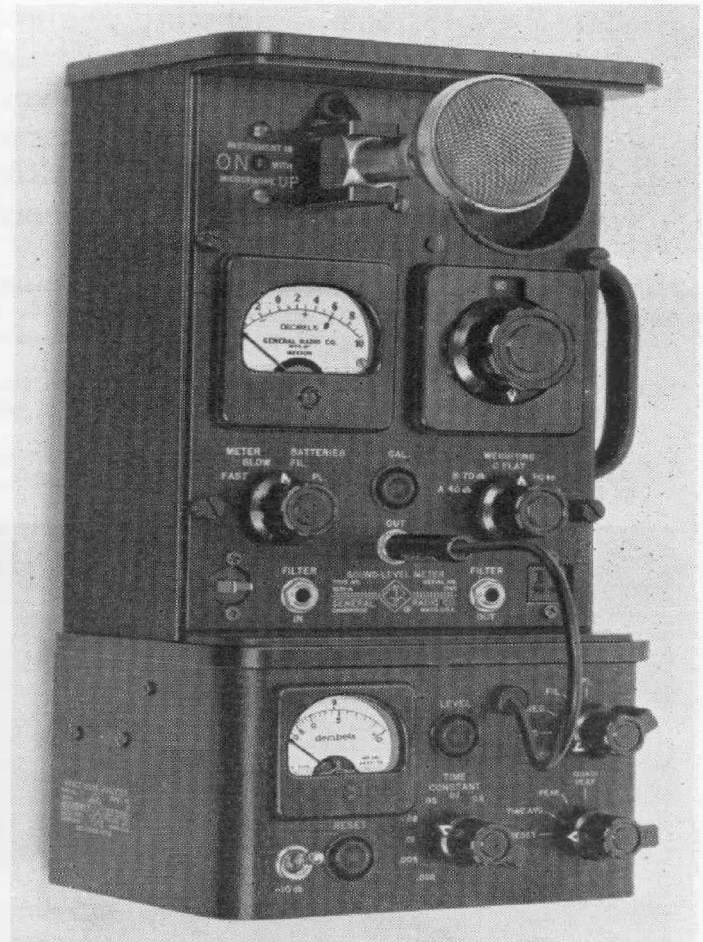



display of the sound wave from a small 1800-lb drop hammer in an open field. The microphone was 24 feet from the hammer, and the maximum level observed is 119 db. (This is the very faint peak 8.5 small divisions above the reference line.) The time scale along the horizontal axis is 10 milliseconds per small division. The usual very rapid rise and fast decay is very clearly shown here. But in addition there is a low-frequency variation having a period of about 25 milliseconds (40 cps), which is a ringing of the hammer. This type of oscillation is not so apparent in the oscillograms taken close to the hammer. At a distance of 3 feet, for example, the oscillograms are very similar to those of Figures 1 and 2. A typical peak level for this small hammer at a distance of 3 feet is 127 db. The difference in shape of the oscillograms at these distances is a result of the appreciable attenuation of high-frequency components and relatively small attenuation of the low-frequency component.

Need for a New Instrument

When a standard sound-level meter is used to measure such noises, the momentary reading obtained at each impact seems to have little significance. The sound level meter is inadequate because an impact sound does not remain at any particular level for a time that is comparable to the time constants of the meter, which are of the order of two-tenths of a second. The meter reading does show a momentary rise and decay, but the maximum reading obtained is commonly 15 to 30 db below the peak level of the wave.

A cathode-ray oscillograph does not have this limitation. Its moving element is an electron beam, which has so little mass that it can easily be made to move in accordance with the instantaneous

sound pressure. By photographing the displayed oscillograph pattern, one obtains a record of a noise of the type shown in Figures 1, 2, and 3.

The equipment required to obtain such a record is complicated, expensive, and bulky. A cathode-ray oscillograph, alone, has many controls, and displaying transient sounds on this device is a complicated operation. As a result, only a few, well-equipped, research laboratories have undertaken a serious study of impact sounds. To set up useful criteria for judging the significance of these sounds, a great deal of experimental data must be accumulated. The collection of these data has been seriously hampered by the lack of simple means of measurement.

The variability of some impact sounds provides further evidence of the need for simple measuring equipment. For example, tools using explosive cartridges for setting fastening devices in concrete produce sounds that vary considerably in level from one shot to the next. Therefore, a number of samples of such sounds should be measured to determine this variability; and a simple measuring instrument makes such a study practical.

The response of the hearing mechanism to impact sounds is appreciably different from that to steady sounds. This difference is due in part at least to certain delays inherent in the action of the hearing mechanism. These delays are comparable to the time constants of impact sounds. The delay in the action of the middle ear muscles, for example, is probably of the order of ten milliseconds or more.² Thus, on some impact sounds no appreciable action of these muscles will occur until after the sound

² W. A. Rosenblith, "Electrical Responses from the Auditory Nervous System," *Annals of Otolaryngology, Rhinology and Laryngology*, September, 1954, Vol. 63, No. 3, pp. 839-860.

is essentially completed. Because of this delay, one would expect the character of an impact noise in the first few milliseconds to be of greater significance than the behavior after longer periods.

The measurement of impact sounds by cathode-ray oscillographs can yield a large amount of information. But oscillograms cannot be used directly in rating a noise. We need to have a few numbers that will characterize the sound wave, so that we can use the numbers in plotting graphs and in setting up tentative criteria for impact noises. A study of the patterns of impact noise oscillograms leads to the conclusion that two obvious numbers to use are the maximum instantaneous level and some measure of the time duration of the wave.

Description of Impact Noise Analyzer

These two values are readily measured by the new TYPE 1556-A Impact Noise Analyzer, shown in Figure 4 attached to a sound-level meter. Both the peak level and the duration of a single impact can be measured. The instrument contains a battery-operated transistor amplifier, which is highly stabilized by negative feedback. This amplifier simultaneously drives three a-c voltmeter circuits, which consist of rectifiers, storage capacitors, and a common electronic d-c voltmeter, as

illustrated in the simplified schematic of Figure 5.

The electrical storage system, which is a capacitor charged by the rectifier, makes it possible to measure all three characteristics on a single impact with only one indicating meter. This storage system is an essential element in obtaining a satisfactory reading on an indicating instrument for these very short duration sounds. In order that the charge remain stored in the capacitor for some time, the electrical leakage of the rectifier must be extremely low in the reverse direction. This characteristic is obtained in recently developed silicon-junction diode rectifiers.

When the measurement of a single impact is completed, the capacitors in the metering circuit are discharged by switching to a position called "RESET." Then the instrument is ready for measuring another impact.

The three characteristics of a sound that can be measured by means of the Impact Noise Analyzer are labeled on the instrument as "QUASI PEAK," "PEAK," and "TIME AVG" (time average).

The "QUASI PEAK" is a continuously indicating measure of the higher sound-pressure levels occurring just before the time of indication. The electrical circuit of the "QUASI PEAK"

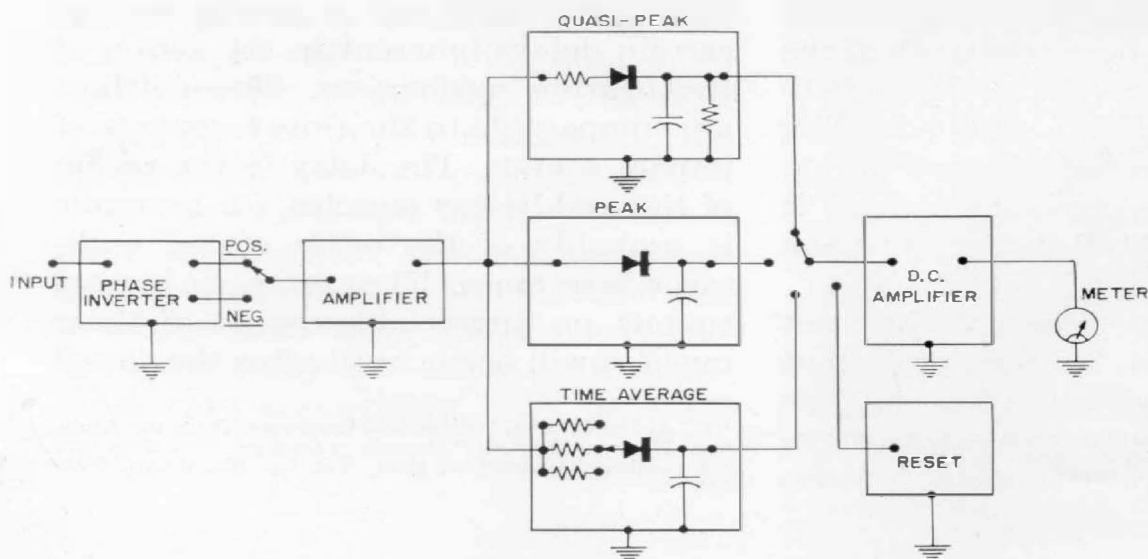

Figure 5. Simplified functional diagram of the Impact Noise Analyzer.



system has a fast rise time (a fraction of one millisecond) and a slow decay time (about six-tenths of a second) so that the fast indicating meter on the instrument can follow reasonably well the peak levels of sound. This measure of a sound is useful for repeated impacts. It also serves as a convenient indicator for calibrating the system, and it has the characteristics proposed as standard for measuring electrical impulse noise.³ Incidentally, there is some evidence that in general it can be used as a single measure of loudness of noise with appreciably better results than is possible with the rms meter specified in the sound-level meter standard.

The "PEAK" is the maximum sound-pressure level reached by the noise after the analyzer control is switched out of the "RESET" position. The time required for this instrument to note the peak level is so short (of the order of one ten-thousandth of a second) that for sound waves it can be regarded as instantaneous. This "PEAK" level is stored electrically for a number of seconds, so that the level can be read on the indicating instrument at leisure.

Comparisons have been made between the peak levels of impact sounds measured on this instrument and those measured by the cathode-ray oscillograph technique. The agreement is very satisfactory, being generally within one decibel.

The time-average level is obtained by charging a capacitor through a rectifier and a series resistor. Seven different values of charging time are provided, ranging from 2 milliseconds to 0.2 second. This time-average level is a measure of the level maintained over a period of time. The actual averaging

time is set by the charging time and the shape of the pressure wave. The time-average level is also stored in an electrical capacitor, so that it can be read on the indicating instrument at leisure.

The difference between the peak level and the averaged level is a measure of the time duration of the wave. How a particular time duration for these complicated impact waves is to be specified is not obvious. If they were simple rectangular pulses, there would be no problem. Such pulses will be used to illustrate the basis of the procedure adopted for more complicated waves.

Assume that the charging time of a rectifier circuit is set to be 0.01 second. If a constant voltage is suddenly applied to this rectifier circuit, current flowing into the capacitor will result in an increase in voltage across it. The longer this voltage is applied, the closer will the voltage across the capacitor approach the applied voltage. Thus, if it lasts for 0.01 second, the capacitor voltage should be 4 decibels less than the applied voltage. If it lasts for only 0.002 second, however, it should be 15 decibels less than the applied voltage. This relation is shown as the lower curve in Figure 6. Some experimental results obtained by using the impact noise analyzer to measure known rectangular pulses are shown also in Figure 6. The ratio of the applied voltage to the voltage across the capacitor is plotted in decibels along the horizontal axis, and the ratio of the duration of the applied voltage to the charging time of the rectifier circuit is plotted along the vertical axis. The close agreement of the measured values to the theoretical relation indicates that the circuits are operating as expected.

If a rectangular pulse of unknown duration is applied to this instrument, its duration can be determined from

³ American Standards Association, C63.2-1950. "Proposed American Standard Specifications for a Radio Noise Meter, 0.015 to 2.5 Megacycles/Second."

these measurements. The "PEAK" circuit charges very quickly to the full applied voltage so it is used as the reference, and the difference in decibels between the peak value and the averaged value is used with the chart to determine the duration of the pulse. For example, assume that the indicated peak level is 138 db and the level with an averaging time of 0.002 second is 130 db. The difference in level is 8 decibels. From the chart it is seen that this level difference corresponds to a time ratio of 0.5. The pulse, therefore, was one-half of 0.002 second, which is 0.001 second, or 1 millisecond.

Impact noises are not so simple as rectangular pulses, however, as is shown by the oscillograms of Figures 1, 2, and 3. Rather, they appear to be, to a first approximation, exponentially decaying random noises. For such an applied

Figure 6. Chart showing the relations between the ratio of the peak to averaged value and the time constants of an impact and of the circuit. The lower curve is for a rectangular pulse, and the upper one is for the usual impact noises.

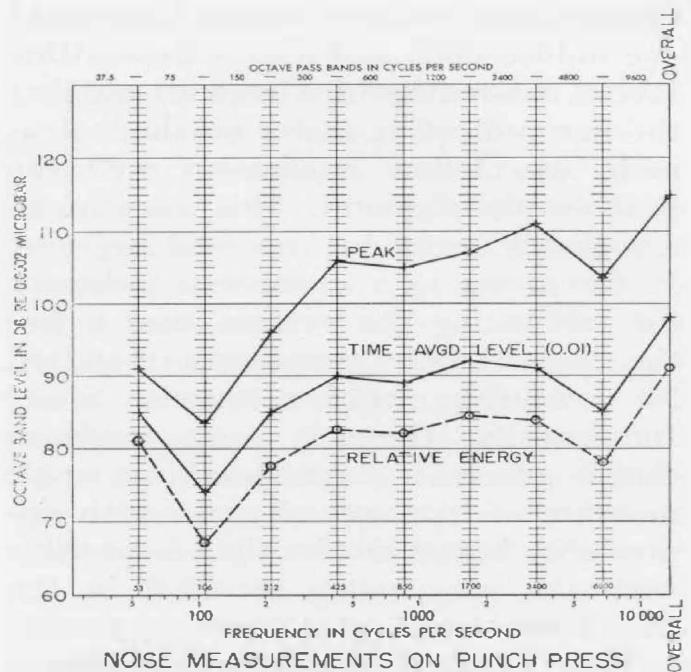
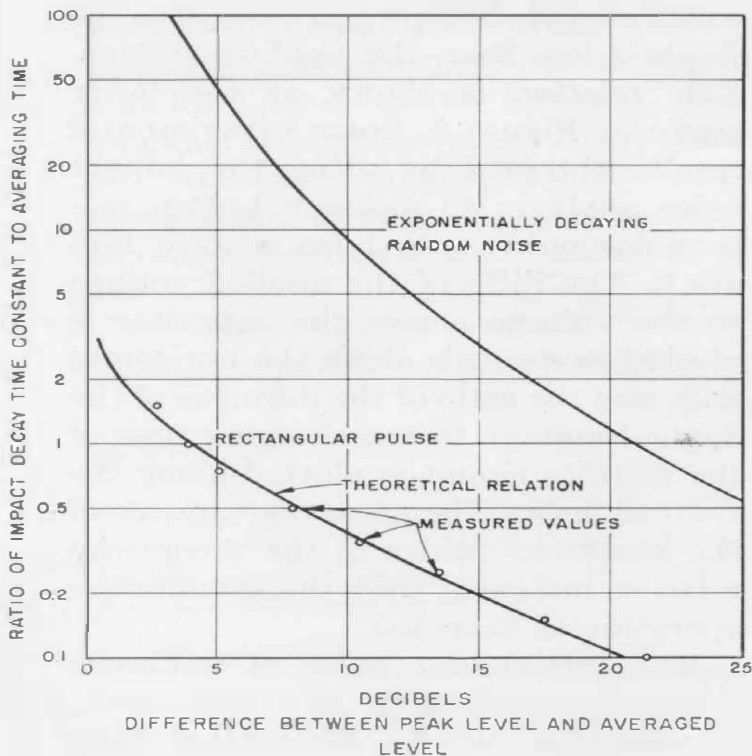

Figure 7. The results of an octave-band analysis of the noise from a single impact of a punch press as measured by the impact noise analyzer on the output of the octave-band analyzer.

wave, a relation of the type previously given for rectangular pulses can be computed, and is shown in Figure 6.* Here the decay time constant is defined in the same way as it is done in electrical circuits. The time constant is the time required for the wave to drop 8.7 db in level from its initial value.

A particular example will show how this relation can be used. Measurements of a small punch press stamping out blanks gave a peak level of 115 db and a time-averaged level of 98 db when a time constant of 0.01 second was used. The difference in level is 17 decibels. From the chart this difference corresponds to a time ratio of 2. The equivalent impact decay time is then 2 times 0.01, which is 0.02 second, or 20 milliseconds.

* The computed relation shown in Figure 6 is based on the assumption that the charging time of the peak circuit is of the order of a hundredth to a thousandth the decay time of the exponentially decaying wave. This assumption appears to be justified for most of the impact noises encountered in industry.



When this procedure is used on the impact noises, whose oscillograms are shown in Figures 1 and 2, equivalent decay times of about 30 milliseconds for the punch press and about 4 milliseconds for the handclaps are obtained. These values appear to correspond reasonably well with estimates made from the oscillograms.

In addition to its use for measuring impact noise directly, the impact noise analyzer can measure the output of a spectrum analyzer. For example, the impact noise of a punch press was measured by using an octave-band analyzer and the new impact meter. The results are shown in Figure 7. The upper curve is a plot of the peak level observed in the band, and the middle curve is a plot of the time-averaged level. The overall levels are shown at the right.

It is not clear that the measured peak level in a band has real significance by itself, since this peak is not one that actually occurs in the physical sound wave. But, when it is taken in conjunction with the time-averaged level, one can get an estimate of how the energy in the sound is distributed in frequency. Thus, the peak and time-averaged level can be used to determine an equivalent decay time for the noise in each band. Then, with the assumption that the

noise wave in each band is an exponentially decaying one, the square of the pressure wave can be integrated with time and the result is plotted on the chart as relative energy. The absolute position here is purely arbitrary. These points show a distribution in frequency that is more uniform than the distribution shown for the peak level, which means that, in general, lower frequency components decay less rapidly than do higher frequency ones.

The calculated decay time of the noise in the different bands is shown in the curve of Figure 8. These results show a variation in decay time constant from 300 milliseconds, or 0.3 second, in the lowest band to a time constant of only 13 milliseconds for the noise in the band from 2400 to 4800 cycles per second. This result is what one would expect, since the high-frequency energy is usually dissipated much more rapidly than the low-frequency energy.

Other Uses

In addition to its use in evaluating impact noise and vibration, the Impact Noise Analyzer shows promise of being useful in many other types of measurement. Among those already suggested are the measurement of reverberation time, of loudness, and of the damping effect of sprayed coatings.

— ARNOLD P. G. PETERSON

Figure 8. The time constant of analyzed noise from a punch press.

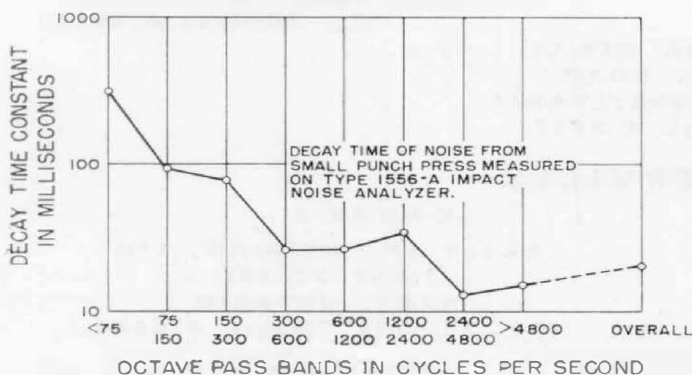

Acknowledgment—The author wishes to acknowledge helpful discussions on this subject with Dr. Jerome R. Cox, Jr. of the Central Institute for the Deaf; and the assistance of Mr. Robert J. Ruplenas of the General Radio Company, in the development of the instrument described here.



SPECIFICATIONS

Input Level: Any voltage between 1 and 10 volts for normal range. Levels below 1 volt reduce the range of reading.

Input Impedance: Between 25,000 and 100,000 ohms, depending on LEVEL control setting.

Frequency Range: 5c to 20 kc

Level Indication: Meter calibrated in decibels from -10 to +10. Added attenuator switch increases range by 10 db.

Peak Reading: Rise time is less than 50 microseconds for a value within 1 db of peak value (for rectangular pulses). Storage time at normal room temperature is greater than 10 seconds for 1 db decrease in value.

Quasi Peak Reading: Rise time of less than 1/4 millisecond and decay time of 600 ± 120 milliseconds for rectifier circuit.

Time Average Reading: Charge time of rectifier circuit selected by seven position switch, having times of .002, .005, .01, .02, .05, .1, and .2 seconds for the resistance-capacitance time con-

stant. Storage time at normal room temperature is greater than 1 minute for 1 db decrease in value.

Source: A sound-level meter or spectrum analyzer should ordinarily be used to supply the analyzer input.

Input Terminals: An attached cord with phone plug at one end.

Batteries: One 1 1/2-volt size D flashlight cell (Rayovac 2LP or equivalent) and one 45-volt B battery (Eveready 455 or equivalent) are supplied.

Tube Complement: One TYPE CK-6418 tube; Three TYPE 2N105 transistors or equivalents.

Cabinet: Aluminum, finished in organic black. Carrying case supplied.

Mounting: May be fastened to end frame of TYPE 1551-A Sound Level Meter.

Dimensions: 7 1/2" (wide) × 4 1/4" (deep) × 6 1/2" (high).

Net Weight: Instrument, 4 1/2 pounds; Carrying case, 1 pound.

Type		Code Word	Price
1556-A	Impact Noise Analyzer	MEDAL	\$210.00

A NEW General Radio net-price list is enclosed with this copy of the EXPERIMENTER. As there have been many revisions, please be sure to use this latest price information when ordering. The list is of convenient size for filing with your copy of our catalog.

The prices are net f.o.b. Cambridge or West Concord, Mass. Customers in other countries are reminded that quantity discounts shown for some items apply only for domestic sales.

GENERAL RADIO COMPANY

275 MASSACHUSETTS AVENUE
CAMBRIDGE 39 MASSACHUSETTS
TELEPHONE: TRowbridge 6-4400

BRANCH ENGINEERING OFFICES

NEW YORK 6, NEW YORK
90 WEST STREET
TEL.—WOrth 4-2722

LOS ANGELES 38, CALIFORNIA
1000 NORTH SEWARD STREET
TEL.—Hollywood 9-6201

CHICAGO 5, ILLINOIS
920 SOUTH MICHIGAN AVENUE
TEL.—WAbash 2-3820

SILVER SPRING, MARYLAND
8055 131h STREET
TEL.—JUniper 5-1088

PHILADELPHIA OFFICE
1150 YORK ROAD
ABINGTON, PENNSYLVANIA
TEL.—HAncock 4-7419

REPAIR SERVICES

WEST COAST
WESTERN INSTRUMENT CO.
826 NORTH VICTORY BOULEVARD
BURBANK, CALIFORNIA
TEL.—Victoria 9-3013

CANADA
BAYLY ENGINEERING, LTD
FIRST STREET
AJAX, ONTARIO
TEL.—Toronto EMpire 8-6866