

THE

# General Radio EXPERIMENTER

VOLUME XXVII No. 12

MAY, 1953

Copyright, 1953, General Radio Company, Cambridge, Mass., U. S. A.



ELECTRICAL MEASUREMENTS AND THEIR INDUSTRIAL APPLICATIONS

## A NEW 2-AMPERE VARIAC® TWICE THE POWER FOR THE SAME PRICE

<p><i>Also</i> IN THIS ISSUE</p> <p style="text-align: right;"><i>Page</i></p> <p>TYPE 1551-P1 CON- DENSER MICRO- PHONE SYSTEM... 2</p>
---

● A NEW VARIAC, the TYPE V-2, is the latest addition to the General Radio line of adjustable autotransformers. Designed to supplant the older TYPE 200-B, with which it is generally interchangeable, TYPE V-2 offers *twice the power rating for the same*

*price.* In addition, TYPE V-2 incorporates such desirable features of V-line Variacs as the GR unit brush and Duratrak, the stable brush track that resists deterioration from use and abuse.

Like the TYPE 200-B, the new TYPE V-2 is intended primarily for panel mounting, and so is supplied with a reversible dial-plate (0-115 volts; 0-135 volts) and pointer knob for panel installation. Although the depth behind panel is slightly greater, mounting bolts and bolt locations for TYPE V-2 are the same as for TYPE 200-B, as is the radial clearance required back of panel. This latter was accomplished by operating the brush on the face of the winding, instead of on the periphery, and by optimum use of copper and modern core material.

Unlike TYPE 200-B, TYPE V-2 has a metal base for improved cooling and strength and a terminal board on which the circuit is clearly indicated. This unit can be operated at both 50 and 60 cycles for either line or overvoltage connections.

Figure 1. Designed for panel mounting, the new Type V-2 Variac Autotransformer gives more watts per dollar than its predecessor.

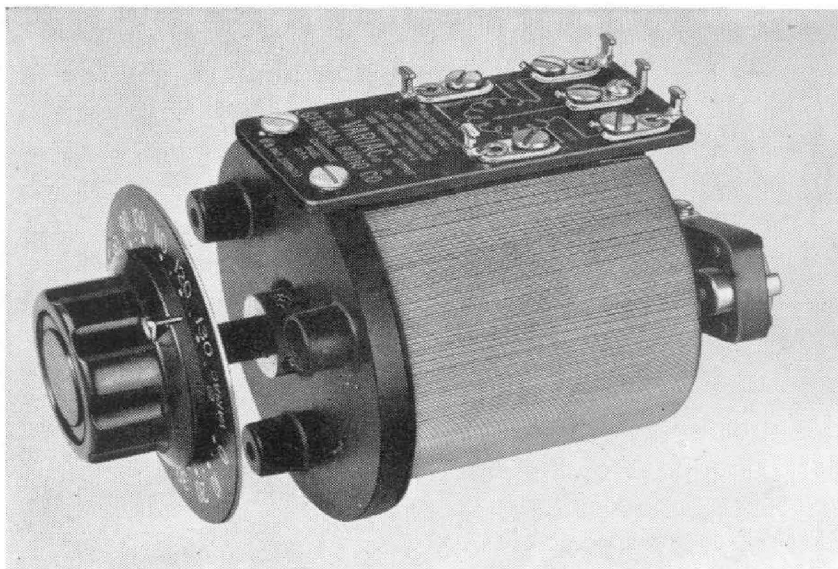

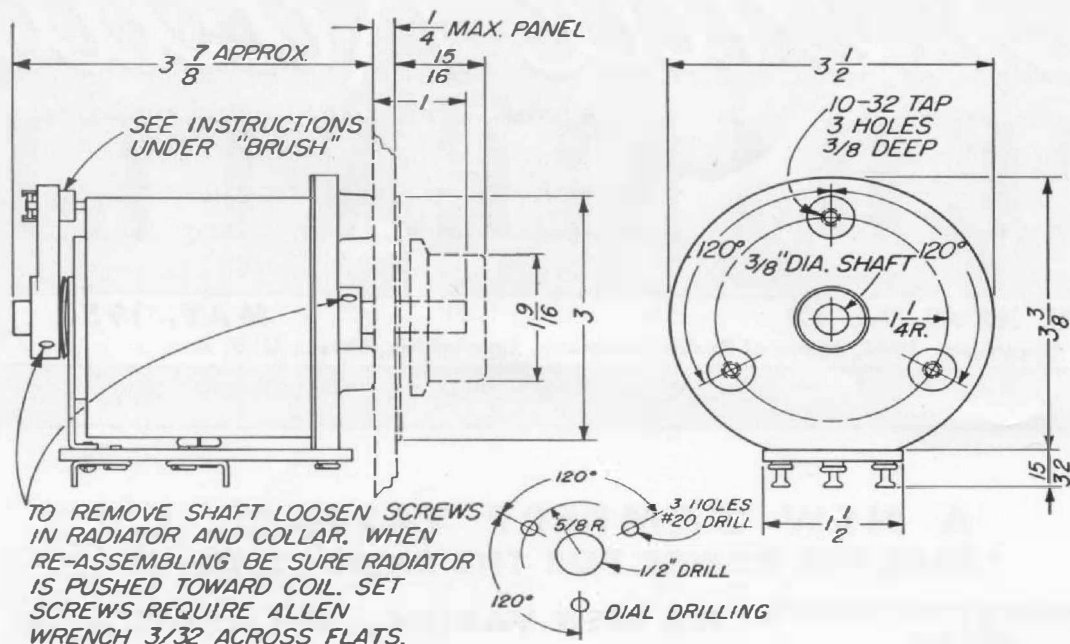

Figure 2. Dimensions of the Type V-2 Variac. Mounting dimensions and radial clearance are the same as for the older Type 200-B. Depth behind panel is slightly greater.

The TYPE V-2 assembly is a strong, simplified design that will withstand shock and vibration tests such as those under MIL-T-945-A. With its rating of

0.345 KVA and its many desirable features, TYPE V-2 Variac offers excellent value for your autotransformer dollar.

— GILBERT SMILEY

**SPECIFICATIONS**

**Input Voltage:** 115 volts.  
**Load Rating:** 0.345 kva.  
**Line Frequency:** 50 to 60 cycles.  
**Output Voltage:** Overvoltage connection, 0 to 135 volts; line-voltage connection, 0 to 115 volts.  
**Rated Current:** 2 amperes.

**Maximum Current:** Overvoltage connection, 2 amperes; line-voltage connection, 3 amperes.  
**No-Load Loss at 60 Cycles:** 3.5 watts.  
**Driving Torque:** 15 to 30 inch-ounces.  
**Dimensions:** See Figure 2.  
**Net Weight:** 3 1/2 pounds.

Type		Code Word	Price
V-2	2-Ampere Variac®.....	BEADY	\$12.50

**TYPE 1551-P1 CONDENSER MICROPHONE SYSTEM**  
**TINY MICROPHONE EXTENDS USEFUL FREQUENCY RANGE OF**  
**TYPE 1551-A SOUND-LEVEL METER TO 15 KILOCYCLES**

During the development of the TYPE 1551-A Sound-Level Meter,<sup>1</sup> much thought was given to the choice of microphone. Because of its low cost, high sensitivity, and good frequency response, the Rochelle-salt crystal microphone was chosen as standard equip-

ment. It was recognized, however, that no one microphone would satisfy all the demands that would be made on a sound-level meter and that special purpose or accessory microphones would be needed. A dynamic microphone has already been made available<sup>2</sup> for those applications

<sup>1</sup>E. E. Gross, Jr., "TYPE 1551-A Sound-Level Meter," *General Radio Experimenter*, Vol. XXVI, No. 10, March, 1952.

<sup>2</sup>E. E. Gross, Jr., "A Dynamic Microphone for the Sound-Level Meter," *General Radio Experimenter*, Vol. XXV, No. 11, April, 1951.



requiring a long cable between microphone and sound-level meter. There are also many measurements where a wide frequency range is essential. For example, when response measurements are to be made over the full range of high-fidelity loud-speaker systems, the measurement microphone must be usable from 20 to about 15,000 cycles per second, which is well beyond the requirements of the standard<sup>3</sup> on sound-level meters. Similarly, when noise measurements are made on jet engines, air blasts, knitting and weaving rooms in textile mills, or when they are made to evaluate deafness risk<sup>4</sup> or to aid in solving an

annoyance problem, good high frequency response is essential.

The new TYPE 1551-P1 Condenser Microphone System was developed to satisfy this need for making sound measurements over wide frequency ranges. It takes advantage of the wide frequency range of the amplifier in the TYPE 1551-A Sound-Level Meter, and the combination has a good frequency response characteristic from 20 to 15,000 cycles per second.

This new accessory is a portable, battery-operated unit just as the sound-level meter is, so that the complete measuring equipment is readily portable. The basic elements are the condenser microphone, a preamplifier, an extension cable, and a battery unit. As shown in Figure 1, the condenser microphone

<sup>3</sup>ASA, American Standard for Sound-Level Meters for Measurement of Noise and Other Sounds, Z-24.3, 1944.

<sup>4</sup>Gordon D. Hoople, "Unsolved Problems Relating to Hearing Loss in Industry," *Journal of the Acoustical Society of America*, Vol. 24, No. 6, pp. 765-766, November, 1952.

Figure 1. View of the Type 1551-A Condenser Microphone System attached to the Type 1551-A Sound-Level Meter. Inset shows microphone, microphone base, and preamplifier.

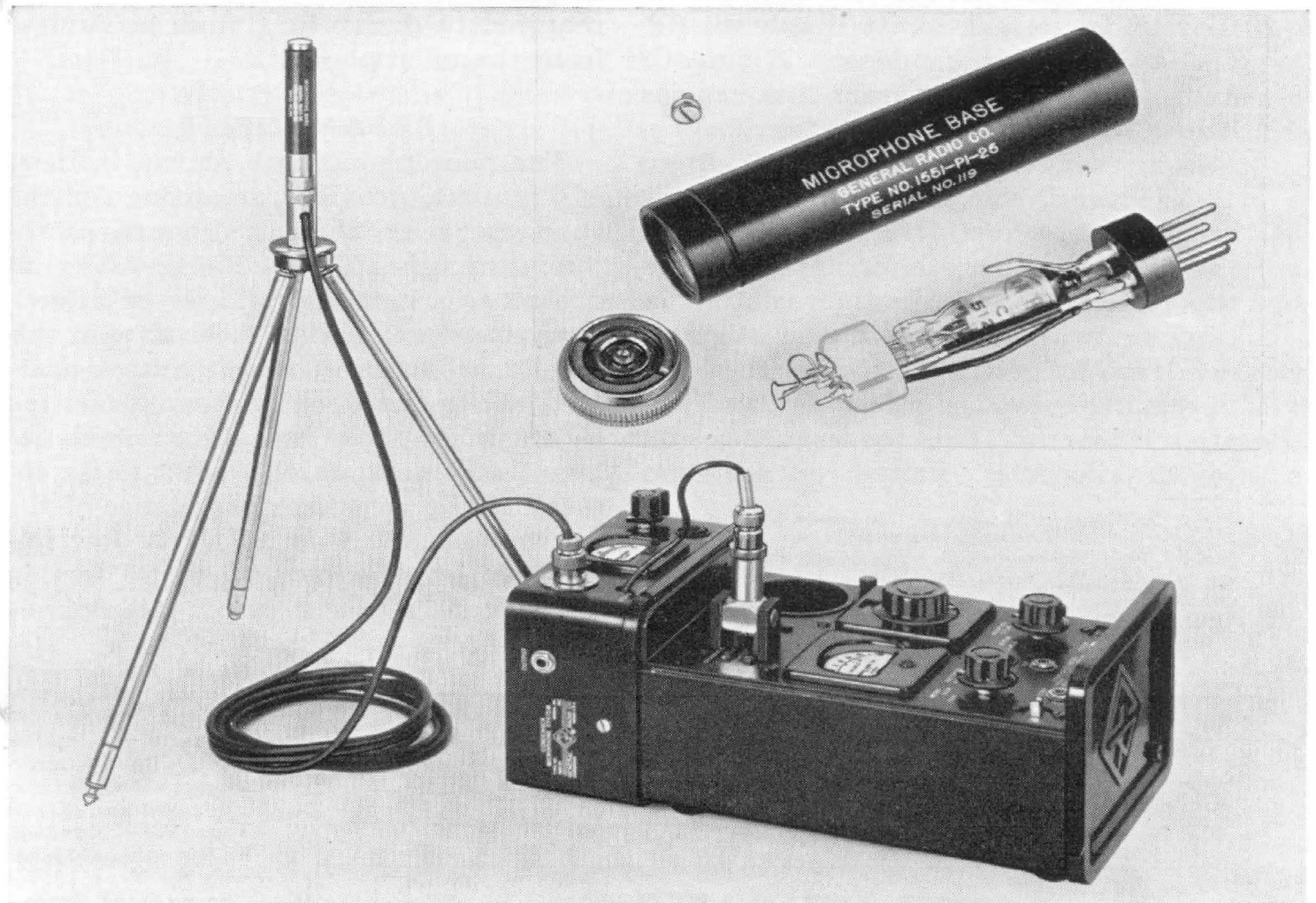

mounts on a small cylindrical base which houses a sub-miniature tube preamplifier. The microphone base plugs into one end of a 10-foot extension cable which has a tripod fitting. The other end of the cable plugs into a compact, battery-operated power supply, which is readily fastened to the end of the sound-level meter cabinet. Connection is made to the sound-level meter input or microphone socket by a short flexible cable on the power supply.

### MICROPHONE CHARACTERISTICS

The Altec TYPE 21-C Condenser Microphone used with this system is well suited to making acoustic measurements over wide frequency ranges. It is similar to the earlier TYPE 21-B Microphone<sup>5, 6</sup>, but modifications in the cap have extended the high-frequency response. The typical response curves in Figure 2 show that the response of the microphone to sounds normal to its diaphragm (0° or perpendicular incidence) is smooth and essentially flat from frequencies below 20 cycles to 8 kilocycles. The response then remains within  $\pm 3$  db to 14 kilocycles. The small size of this microphone is a distinct advantage from the measurement standpoint since, as the curves show, it limits variation in response with changes in the angle of incidence of sound striking the diaphragm. Figure 2 shows that this variation is less than 6 db for frequencies up to 10 kilocycles. Larger microphones

commonly used in sound measurements are much poorer in this respect. For example, the difference between grazing (90°) and perpendicular (0°) incidence response for the standard crystal microphone or the dynamic microphone (TYPE 759-P25)<sup>2</sup> is 6 db at approximately 4,000 cycles. By making such comparisons, it can be seen that this new microphone shows a substantial improvement in response over the microphone furnished with the sound-level meter or the TYPE 759-P25 Dynamic Microphone. The sensitivity of the microphone is approximately -48 db (re 1 volt per  $\mu$ bar) which is 10 db greater than the crystal microphone normally used with the sound-level meter. The output impedance is approximately 6  $\mu$ mf. At low frequencies this is an extremely high source impedance (over 1,000 megohms at 20 cycles), so an amplifier with high input impedance is required to derive maximum usefulness from the microphone.

### PREAMPLIFIER

The microphone base, shown in inset of Figure 1, provides mounting for the condenser microphone and houses a sub-miniature tube (TYPE CK-512-AX) connected as a cathode follower or impedance transformer. Use of the tube in this fashion produces an output voltage nearly equal to the signal voltage generated by the microphone but at an impedance level of approximately 6,000 ohms instead of the very high impedance of the microphone. At this relatively low impedance level, cables up to 25 feet in length can be used between microphone

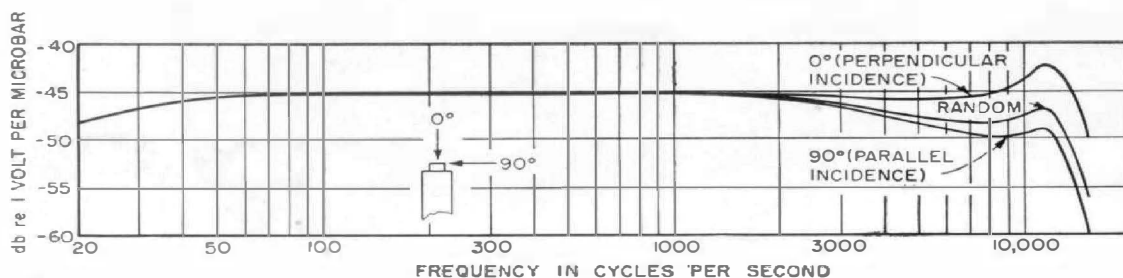

Figure 2. Frequency-response characteristics for different directions of incident sound. These characteristics show the overall response of the Type 1551-P1 Condenser Microphone System with the Type 1551-A Sound-Level Meter.

<sup>5</sup>J. K. Hilliard, "Miniature Condenser Microphone," *J. of the Soc. of Motion Picture and Television Engineers*, Vol. 54, pp. 303-314, March, 1950.

<sup>6</sup>R. J. Carrington, "Miniature Capacitor Microphone-Omnidirectional at All Frequencies," *Electrical Manufacturing*, Vol. 48, No. 4, pp. 128-133, October, 1950.

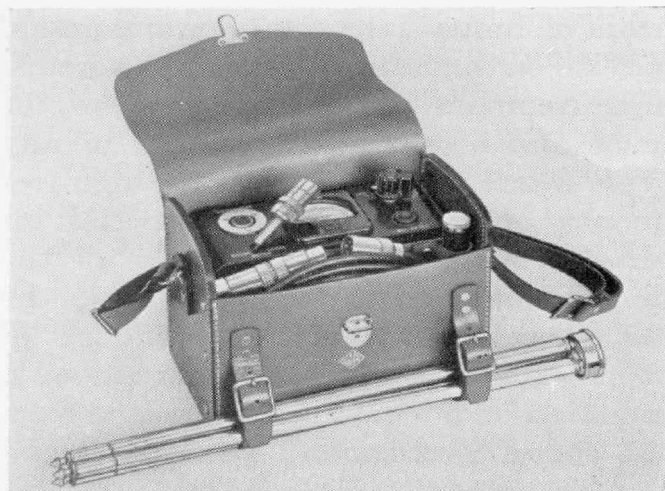

Figure 4. The condenser microphone system is furnished in a compact leather carrying case of top-grain cowhide.

base and sound-level meter without cable correction. Figure 3 is an elementary schematic diagram of the system. As is indicated, no external grid-leak is used to determine the bias for the preamplifier. The insulating material supporting the back plate structure of the microphone is a glass-bonded mica with a leakage resistance of more than  $10^7$  megohms and is specially treated to remove and seal out moisture. So long as the leakage resistance is maintained at this high value, the grid bias is established by the voltage gradient within the electron cloud surrounding the cathode. Under these conditions it has been found that the bias is stable and the noise level over the 20-kilocycle band at the output of the preamplifier is approximately 20  $\mu$ volts or low enough so that sound levels of 40 db (re 0.0002  $\mu$ bar) can be meas-

ured with the system. The output of a 50-db microphone is 20  $\mu$ volts for a sound-pressure level of 30 db (re 0.0002  $\mu$ bar).

### POWER SUPPLY

The battery-operated power supply furnishes the filament and plate supply for the CK-512-AX tube in the pre-amplifier and the 200 volts necessary to polarize the condenser microphone. Polarization is achieved by raising the cathode 200 volts above ground. The 200 volts is accurately determined by using a precision cathode resistor and measuring the cathode current with the panel meter. The normal grid bias is approximately  $-1$  volt, so that when the cathode voltage is 200 volts the polarizing voltage is actually 199 volts. If for any reason the grid bias increases beyond approximately  $-12$  volts, the voltage drop across the preamplifier tube exceeds 100 volts and, since the B battery is 300 volts, it becomes impossible to set the cathode voltage to 200 volts. Thus a warning is given if the polarizing voltage is in error by 6 per cent or more.

The power supply is contained in a simply formed aluminum case finished with black lacquer. As indicated in Figure 1, it can be fastened to the end frame of the sound-level meter. In addition to the short flexible cable on the power supply, which connects the output of the system to the input of the sound-level meter, there is an OUTPUT jack to

Figure 3. Elementary schematic circuit diagram of the condenser microphone system.

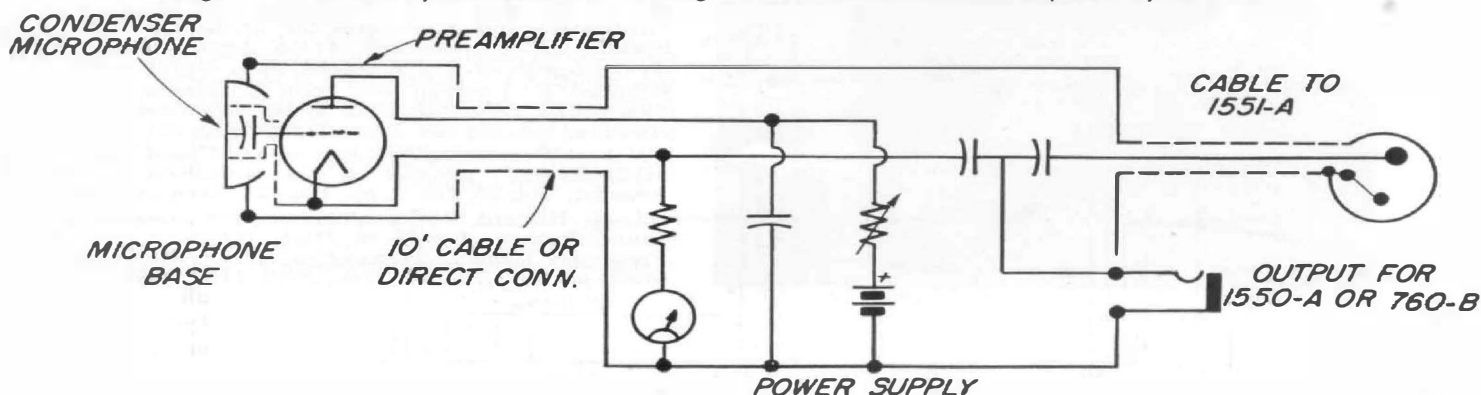

facilitate connection of the microphone system to the input of other instruments such as analyzers or recorders.

### CALIBRATION

The frequency response of the microphone is checked in our testing laboratory, and the 400-cycle level of the system is supplied. In addition, a calibration adaptor is included which permits measurement of the 400-cycle level at any time by using the TYPE 1552-A Sound-Level Calibrator.<sup>7</sup>

### APPLICATIONS

The TYPE 1551-P1 Condenser Microphone System offers in a small, battery-operated, and convenient package a wide-range pickup for the sound-level meter that will prove useful in many sound measurements. It extends the useful range of the sound-level meter from an upper limit of 8 or 9 kilocycles to 15 kilocycles. Not only is its high-frequency operation superior to previous microphones that we have offered, but its low-frequency response remains constant to 20 cycles. It should prove useful in the

<sup>7</sup>E. E. Gross, Jr., "An Acoustic Calibrator for the Sound-Level Meter." *General Radio Experimenter*, Vol. XXIV, No. 7, December, 1949.

Figure 5. High-frequency sound, produced by a power saw, is measured with the sound-level meter and condenser microphone system.

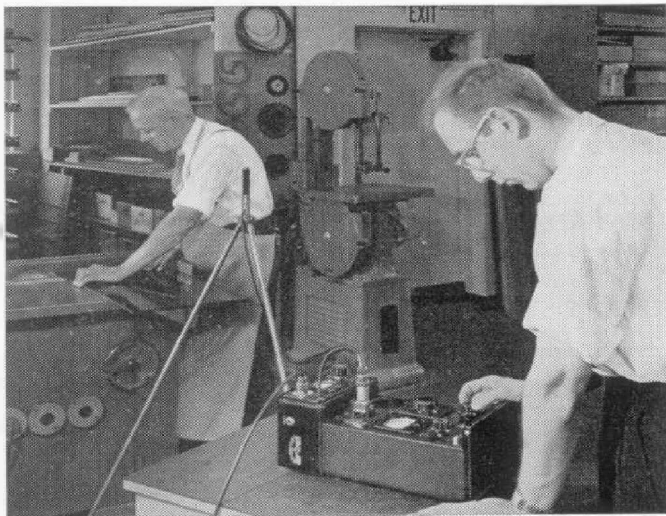

fields of industrial noise measurements, checks on high-fidelity sound systems, measurements of jet-engine noises, or noise and sound measurements of any type where low-, medium-, or high-frequency components are of special interest. Owing to the small size of the microphone and microphone base, the response is relatively independent of sound incidence when the microphone is mounted on a tripod and separated from the sound-level meter. The mechanical impedance of the microphone diaphragm is high enough for measurements of sound pressures in cavities, making the microphone useful for measuring earphone characteristics in earphone-coupling cavities and for measurement of acoustic impedance. The small dimensions and cylindrical shape of the microphone and base make the unit easily adaptable for use as a probe microphone for the study of noise levels in ventilating ducts.<sup>8, 9</sup>

Probe tubes<sup>10</sup> can be used with the microphone for exploring sound fields in small cavities where even this small microphone offers an obstruction.

A probe tube can also be used where the temperature of the sound field to be explored is extremely high and it is desirable to maintain some distance between the microphone and the probe point in the field.<sup>11</sup>

Because of its uniform response, this pickup system should prove especially useful in all measurements where accurate analysis of all components pres-

<sup>8</sup>L. L. Beranek, J. L. Reynolds, and K. E. Wilson, "Apparatus and Procedures for Predicting Ventilating System Noise," *Journal of the Acoustical Society of America*, Vol. 25, No. 2, pp. 313-321, March, 1953.

<sup>9</sup>Clifford E. Piestrup and John E. Wesler, "Noise of Ventilating Fans," *Journal of the Acoustical Society of America*, Vol. 25, No. 2, pp. 322-326, March, 1953.

<sup>10</sup>Robert W. Benson, "Calibration and Use of Probe-Tube Microphones," *Journal of the Acoustical Society of America*, Vol. 25, No. 1, pp. 128-134, January, 1953.

<sup>11</sup>J. K. Hilliard, "Microphone for the Measurement of Sound-Pressure Levels of High Intensity over Wide Frequency Range," *Transactions of the IRE Professional Group on Audio*, PGA-7, pp. 38-45, May, 1952.



ent in the noise is desired. The microphone is very rugged and durable and will withstand very high sound-pressure levels without damage. The upper limit of measurement before its output becomes noticeably distorted is 140 db. When higher sound-pressure levels are to be measured, other versions of this microphone,<sup>12</sup> the Altec TYPES 21BR-180 and 21BR-200, can replace the TYPE 21-C on the microphone base for measurements up to 180 db. For ex-

<sup>12</sup>J. K. Hilliard, "Applications of High-Intensity Microphones," presented at IRE National Convention, Session 38, March 26, 1953, New York City, N. Y.

ample, the 21BR-180 can be used for sound levels from about 60 db to 160 db.

To make the use of the condenser microphone system as convenient as possible, a leather carrying case, illustrated in Figure 4, is supplied as a part of the system. Compartments are provided for each unit for handy storage and transportation of the system. With a case such as this, the problem of keeping all necessary components together and easily available, whether in the laboratory or on field trips, is neatly solved.

— E. E. GROSS, JR.

## SPECIFICATIONS

**Frequency Response:** Useful range of the TYPE 1551-A Sound-Level Meter with TYPE 1551-P1 Condenser Microphone System is 20 cycles to 15 kilocycles. Typical frequency response curves are shown in Figure 2.

**Sensitivity:** Open circuit output of typical microphone and preamplifier is 48 db below one volt per microbar. This sensitivity is about 10 db greater than the crystal microphone supplied with the sound-level meter. When the levels of the sound components exceed 60 db (re 0.0002  $\mu$ bar), the Condenser Microphone System can be connected directly to the TYPE 760-B Sound Analyzer or the TYPE 1550-A Octave-Band Noise Analyzer.

**Calibration:** The output level of the microphone system is measured at several frequencies against a standard microphone that is calibrated periodically by the National Bureau of Standards. The measured level at 400 cycles is supplied. A Calibration Adaptor is provided for use with the TYPE 1552-A Sound-Level Calibrator.

**Maximum Safe Sound-Pressure Level:** At levels above 140 db the output of the microphone becomes non-linear. For levels up to 180 db the Altec TYPE 21-BR-200 can be used in place of the Altec TYPE 21-C. (The TYPE 21-BR-200 is not furnished as part of the TYPE 1551-P1.)

**Cable Correction:** No correction is necessary for the 10-foot cable supplied.

**Internal Noise Level:** Under normal conditions the noise level of the TYPE 1551-P1 Condenser Microphone System is low enough to permit satisfactory measurements of sound-pressure levels as low as 40 db (re 0.0002  $\mu$ bar).

**Output Terminals:** A short flexible output cable on the power unit plugs into the microphone socket of the TYPE 1551-A Sound-Level Meter in place of the standard crystal microphone. In addition, a jack located on the side of the power supply provides a direct connection to the TYPE 760-B Sound Analyzer or the TYPE 1550-A Octave-Band Noise Analyzer.

**Batteries:** One 1½-volt size-D flashlight cell (Eveready 950 or equivalent) and one 300-volt B battery (Eveready 493 or Burgess V-200) are supplied.

**Tubes:** One Raytheon Type CK-512-AX is supplied in the TYPE 1551-P1-25 Microphone Base.

**Mounting:** Microphone on microphone base plugs into one end of 10-foot cable, which has fitting to mount on the tripod. Other end of 10-foot cable connects to power supply unit, which fastens to the end frame of the Sound-Level Meter.

**Dimensions:** Microphone — (diameter)  $\frac{5}{8}$  x (length)  $2\frac{1}{64}$  inches; Microphone Base — (diameter)  $\frac{3}{4}$  x (length) 3 inches; Power Supply — (height) 7 x (length)  $3\frac{1}{4}$  x (width)  $7\frac{1}{2}$  inches.

Leather carrying case with compartment for microphone and microphone base, power supply, 10-foot cable, and calibration adaptor has overall outside dimensions of approximately (height) 7 x (length)  $5\frac{1}{2}$  x (width)  $8\frac{1}{2}$  inches.

**Net Weight:** Altec 21-C Microphone, less than  $\frac{1}{2}$  oz.

Microphone and Base, 1.2 oz.

Power Supply, 3 lbs. 11 oz.

Complete System in Carrying Case, 7 lbs. 6 oz.

Type		Code Word	Price
1551-P1	Condenser Microphone System .....	NONAL	\$225.00

**VISITORS FROM OVERSEAS**

The recent annual convention of the Institute of Radio Engineers afforded a welcome opportunity to greet many of our friends from overseas. Among those visiting our plant after the convention were:

Mr. Marius Berlin, of Radiophon, Paris, exclusive distributors for General Radio products in France and the French colonies; Mr. John C. Lagercrantz, of Stockholm, exclusive distributor for Sweden; and Mr. Harnam V. Montwane, of Eastern Electric and Engineering Co., Bombay, exclusive distributors for India.

We were also privileged to have as guests at our booth in the Radio Engineering Show, and later at our factory, a group of nine overseas business men from Latin America and European countries, who are now on a five-weeks' tour of electronic plants in the United States. This group, all engaged in selling electronic equipment of U. S. manufacturers in their respective countries, are representatives of Ad. Auriema, Inc., New York export agents for U. S. firms. The accompanying photograph shows the group in the General Radio booth at the Radio Engineering Show.



(Left to right) Mr. Mario R. Aguilar, Mexico City; Mr. John Dorman, Ad. Auriema, Inc.; Mr. Richard Bohn, Ad. Auriema, Inc.; Mr. Edmund C. Paca, Ad. Auriema, Inc.; Mr. Nathan Blomhof, Brussels, Belgium; Mr. Guillermo Lucas Royo, Havana, Cuba; Mr. Joseph Sedacca, Ad. Auriema, Inc.; Mr. Angel Mokuvos, Montevideo, Uruguay; Mr. Barnett Phillips, Ad. Auriema, Inc.; Mr. Leopoldo Brandt, Buenos Aires, Argentina; Mr. Andres Lara Saenz, Madrid, Spain; Mr. Anthony Forani, Brussels, Belgium; Mr. Ad. Auriema, President, Ad. Auriema, Inc.; Mr. R. C. Auriema, Ad. Auriema, Inc.; Mr. J. Augusto Gerlinger, Sao Paulo, Brazil; Mr. Richard Minnich, Ad. Auriema, Inc., and Mr. S. W. DeBlois, Export Manager, General Radio Company.

**GENERAL RADIO COMPANY**

275 MASSACHUSETTS AVENUE

CAMBRIDGE 39

MASSACHUSETTS

TELEPHONE: TRowbrldge 6-4400

**BRANCH ENGINEERING OFFICES**

NEW YORK 6, NEW YORK  
90 WEST STREET  
TEL.—WOrth 2-5837

LOS ANGELES 38, CALIFORNIA  
1000 NORTH SEWARD STREET  
TEL.—Hollywood 9-6201

CHICAGO 5, ILLINOIS  
920 SOUTH MICHIGAN AVENUE  
TEL.—WAbash 2-3820