

THE

General Radio EXPERIMENTER

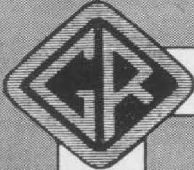

VOLUME XXIII No. 2

JULY, 1948

Copyright, 1948, General Radio Company, Cambridge, Mass., U. S. A.

ELECTRICAL MEASUREMENTS AND THEIR INDUSTRIAL APPLICATIONS

A WIDE-RANGE CAPACITANCE TEST BRIDGE

Also

IN THIS ISSUE

Page

MISCELLANY..... 8

● **WIDE-RANGE** is a term that has no absolute meaning and is perhaps used a bit loosely on occasions in technical and promotional writing. Nevertheless, there is little risk of criticism of its use to describe the TYPE 1611-A Capacitance Test Bridge. This new bridge measures capacitance from 1 $\mu\mu\text{f}$ to 10,000 μf , a range of ten billion

to one. Over this entire range an accuracy of $\pm(1\% + 1 \mu\mu\text{f})$ is maintained.

The new bridge combines the functions of the older TYPES 740-B* and 740-BG* but improves on the performance of each in several important respects. In accuracy, sensitivity, and convenience the performance equals or exceeds that of both previous models. In the very important range below 1000 $\mu\mu\text{f}$, the performance has been markedly improved by the use of a unique zero-compensating circuit. For the measurement of electrolytic capacitors, the new bridge permits the application of a polarizing voltage from a grounded power supply, an important convenience feature. The sensitivity of the detector is controlled by the bridge unbalance in such a manner that balance can be reached with a minimum manipulation of the manual gain control.

The panel controls and their location have been selected with ease of operation in mind. The less-used controls are near the top of the panel, the more used near the bottom where they are most accessible.

The scales of the capacitance and dissipation factor dials are direct reading in capacitance and dissipation factor, and the indexes for both scales are visible through a single window. Since at the index both scales are vertical, both increase upward. Hence increasing readings are obtained for counterclockwise rotation of the right-hand knob, and for clockwise rotation of the left-hand knob.

*Although the TYPE 740-BG Capacitance Test Bridge has been discontinued, the TYPE 740-B is still available. Its limited field of usefulness, as compared to the new bridge, is offset by its lower price.

The Basic Bridge Circuits

The series-resistance capacitance bridge circuit is used, in which the unknown capacitance is measured by variable resistance arms against a fixed standard capacitor, and the dissipation factor of the unknown is measured by a variable resistor in series with the standard capacitor. In order to cover effectively the extremely wide capacitance range, two bridge circuits are used, differing in the value of the standard capacitance used and in the method of connecting voltage source and detector. The necessary changes in circuit connection are all made by the CAPACITANCE MULTIPLIER control.

Figure 2a shows the basic circuit arrangement used for the four lower multiplier positions (0.0001, 0.001, 0.01, and 0.1). Note that the voltage source

is connected across the similar arms of the bridge. With this method of connection, the sensitivity of the bridge depends upon the ratio of the two capacitances. The applied voltage and the detector sensitivity are such that satisfactory balance can be obtained for any ratio up to one hundred to one; that is, for unknown capacitances in the range from 100 $\mu\mu\text{f}$ to 1 μf . Below 100 $\mu\mu\text{f}$, the absolute sensitivity falls off inversely with capacitance, which means that the precision of balance can be expressed as a constant capacitance, in this case of the order of 0.1 $\mu\mu\text{f}$. This precision of balance is adequate for the capacitance balance but does not permit precise dissipation factor determinations for very small values of capacitance.

Figure 2b shows the arrangement

Figure 1. Panel view of the Type 1611-A Capacitance Test Bridge with cover of cabinet removed.

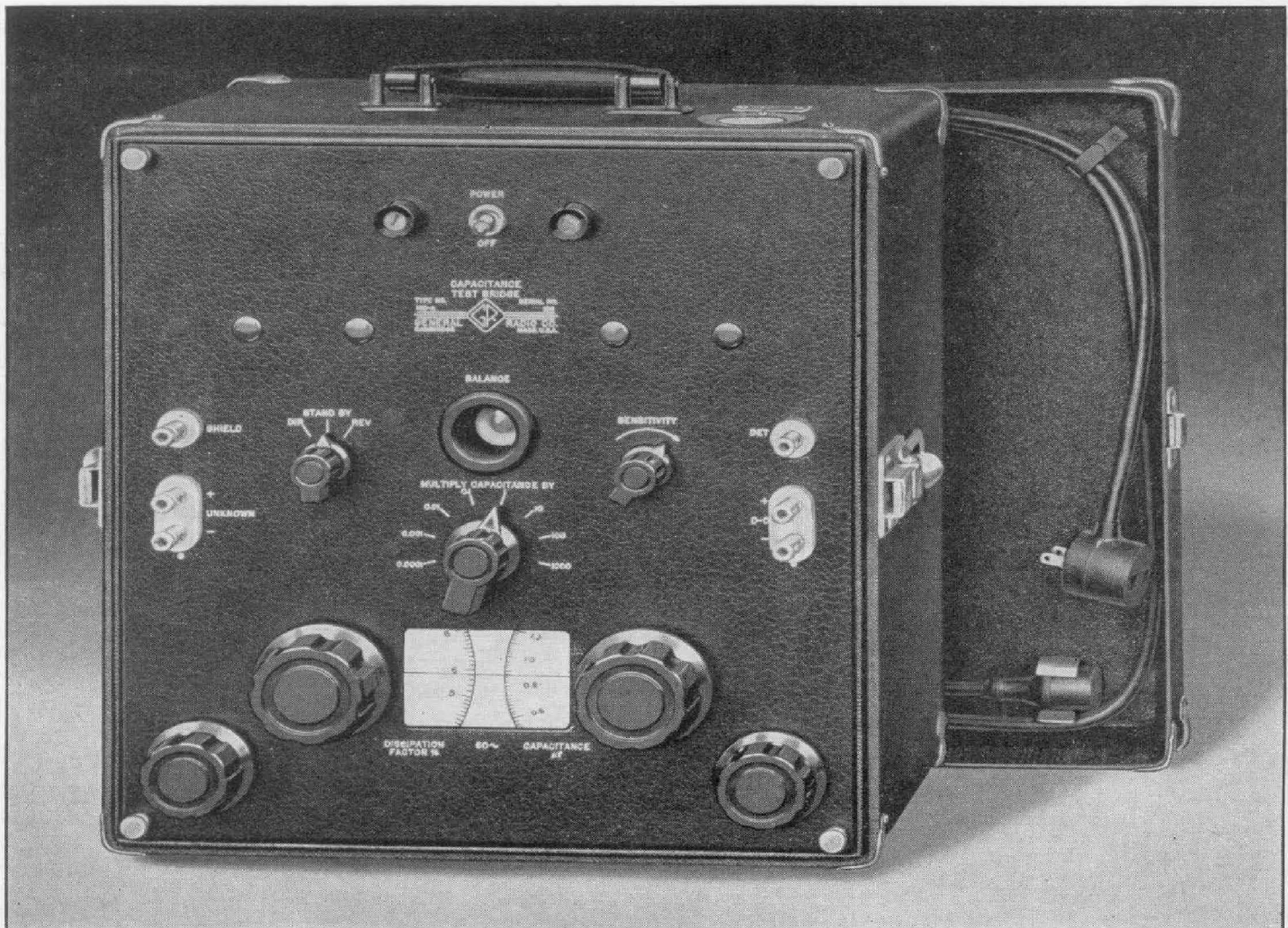

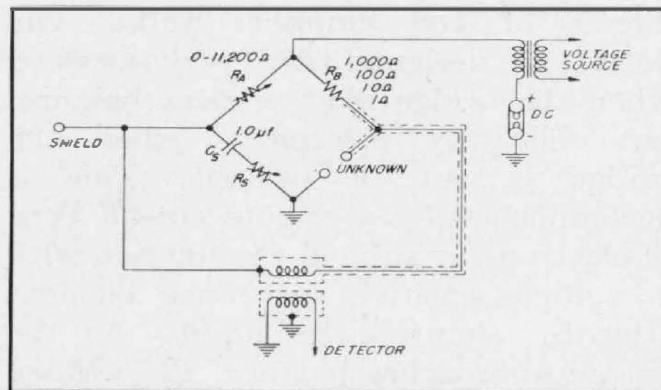
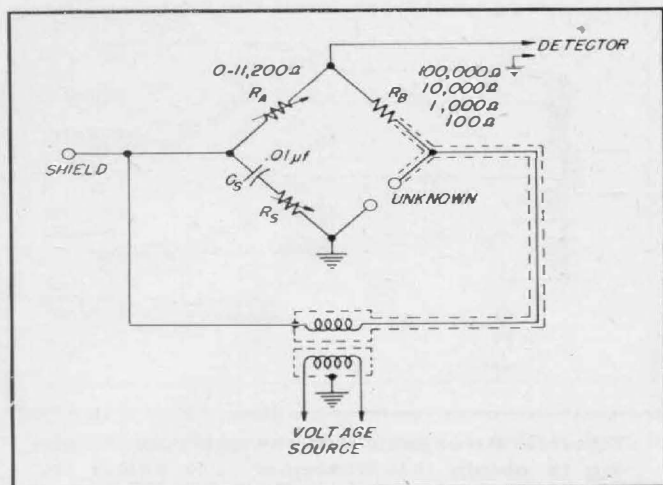

(Left) Figure 2a. Basic bridge circuit used for the four lower multiplier positions.

(Above) Figure 2b. Circuit for the four higher multiplier positions.

used for the four higher multipliers (10, 100, 1000, and 10,000). Note that the voltage source and the detector have been interchanged as compared to the circuit of Figure 2a, and that the capacitance of the standard arm has been changed from $0.01 \mu\text{f}$ to $1.0 \mu\text{f}$. In this method of connection the bridge sensitivity is a function of the ratio of the resistance R_A to the impedance in the standard arm. Unlike the circuit of Figure 2a, the sensitivity of the circuit in Figure 2b does not change as the ratio arm R_B is changed. Optimum sensitivity would be attained with the impedance of the standard arm equal to the resistance R_A . The latter is variable, however, being the balancing arm of the bridge, and, accordingly, the sensitivity varies with the setting of this arm. The reactance of a capacitance of $1 \mu\text{f}$ at 60 cycles is 2650 ohms, and maximum sensitivity is attained when the R_A equals this value. Actually the main decade of the A -arm rheostat goes from 1000 to 10,000 ohms, so that the sensitivity is optimum at about mid-scale and changes relatively little over the range.

Bridge Voltages

Because of the very wide range of input impedance presented by the

bridge, no single source of voltage can be capable of efficiently supplying test voltage for all ranges. Ideally a separate source of proper impedance and voltage might be provided for each multiplier position, but an excellent compromise is obtained by providing four separate sources, one for each pair of the eight multiplier positions. For each pair of positions, a resistance is placed between the bridge and the voltage source such that the same power is delivered to the bridge for each position. The required value of resistance is, of course, the geometric mean of the two values of bridge impedance. The voltages for the four sources are so chosen that, with these series resistances, the maximum safe power is delivered to the bridge for any setting of the multiplier. Figure 3 shows schematically the arrangement. The proper source is selected by a switch mechanically connected to the switch that controls the multiplier ratio of the bridge.

The Detector

The detector system consists of a single stage of amplification and an electron-ray tube used as a visual null indicator. The amplifier is made selective to the operating frequency by a parallel resonant circuit in the plate

circuit of the amplifier tube. The detector is designed to be very sensitive when the bridge is at or near balance, but relatively insensitive when the bridge is out of balance. This is accomplished by a remote cut-off type of electron-ray tube in conjunction with a voltage-sensitive resistance element (thyrite) shunting its input. As the bridge approaches balance, the voltage impressed on the thyrite element is reduced. The resistance-voltage characteristic of the latter is such that the resistance approaches a maximum value as the applied voltage approaches zero. Consequently, as the voltage is reduced, the gain of the system increases because the resistance element in question is located in the plate circuit of a high-impedance tube (see Figure 4).

The indicator tube (TYPE 6U5) is mounted in a slotted cylinder and held in position by a thumbscrew. When the bridge is used in very brightly lighted locations, or when the brilliance of the "eye" has been reduced with age, the tube may be slid back in its mounting to provide additional light shielding.

Compensating Circuits

Any loss in the standard capacitor causes the bridge to read low in dissipation factor by an amount equal to the dissipation factor of the standard capacitor. Although this value does not exceed 0.0003, it must be compensated

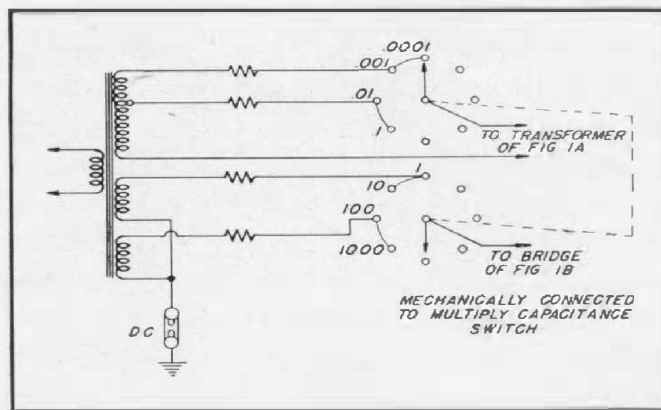

Figure 3. Arrangement of power supply switching to obtain the maximum safe power for each multiplier position.

for in order to realize the maximum accuracy of the bridge. Compensation is accomplished by connecting fixed capacitors across the resistors in the opposite arm, of such value that the product $R_B\omega C_B$ equals the dissipation factor of the standard capacitor.

A new method of compensation is used to eliminate the effects of the zero capacitance and losses across the unknown terminals. It is this compensation which makes possible accurate direct measurements of capacitance and dissipation factor obtained on the lowest multiplier position, without "zero" corrections.

As shown in Figure 5, voltages of adjustable magnitude are fed to the bridge output through a capacitor and a resistor. These voltages are adjusted to cancel the unbalance voltage produced by the zero capacitance. They

Figure 4. Elementary schematic diagram of the null detector.

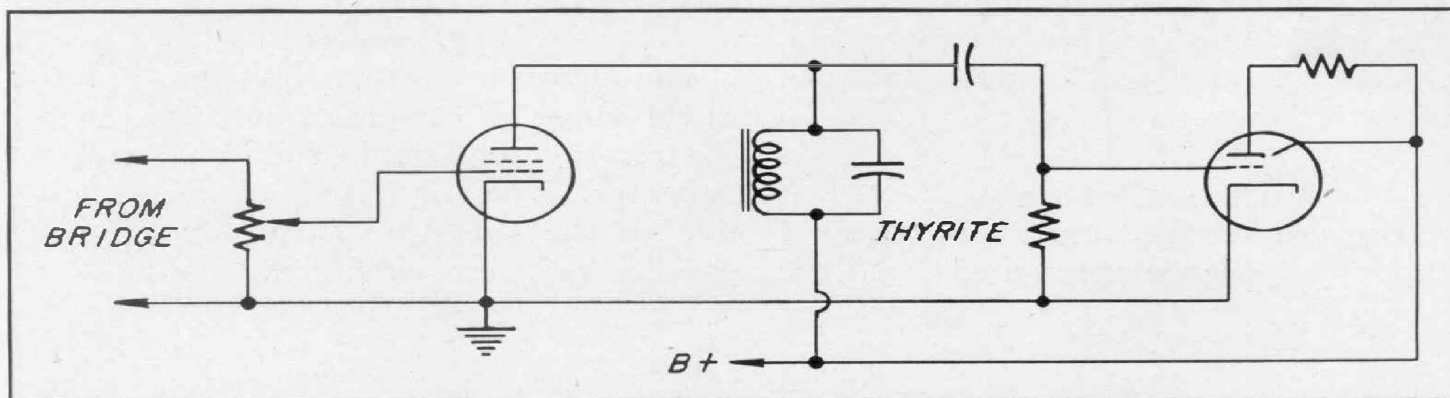

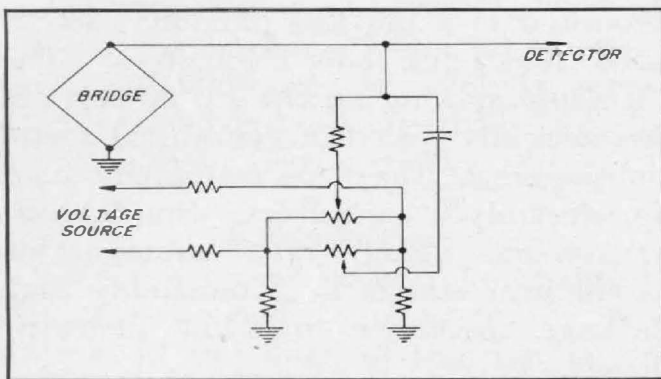

Figure 5. Schematic diagram of circuit used to cancel the unbalance voltage produced by the zero capacitance.

also serve to compensate partially for any leakage through the bridge transformer as well as for any small voltage induced in the amplifier through capacitance coupling to high-voltage leads.

The theory upon which this compensating method is based is as follows. Consider the network of Figure 6 wherein a voltage E' is coupled through an admittance Y_5 to the detector terminals of the four-arm bridge network energized by the voltage E . The condition of balance (zero potential across terminals $A - A'$) is most easily determined by considering the shortcircuit current across the detector terminals. The bridge itself produces a current most conveniently expressed in admittance form as

$$i_{sc} = E \frac{Y_1 Y_4 - Y_2 Y_3}{Y_1 + Y_2 + Y_3 + Y_4} \quad (1)$$

The circuit E' , Y_5 yields a current equal to $E' Y_5$. Equating the sum of the currents to zero and designating as α the ratio E'/E , we have the following expression:

$$Y_1 Y_4 - Y_2 Y_3 + \alpha Y_5 (Y_1 + Y_2 + Y_3 + Y_4) = 0 \quad (2)$$

Figure 6. Equivalent circuit of the bridge and compensating circuit.

This can conveniently be rewritten in the equivalent form

$$(Y_1 + \alpha Y_5) (Y_4 + \alpha Y_5) = (Y_2 - \alpha Y_5) (Y_3 - \alpha Y_5) \quad (3)$$

Equation (3) states that the network of Figure 6 behaves at balance as if an admittance αY_5 were connected in parallel with each arm. Of these fictitious admittances, two are positive and two negative with the choice of sign depending on the polarity of the two voltages involved.

Referring specifically to the bridge network used in the TYPE 1611, it is seen that, by proper choice of the coupling admittance and the voltage, an effective negative capacitance and negative parallel resistance are produced across the unknown terminals to neutralize the real capacitance and resistance that exist there. Simultaneously, the same effective capacitances are placed across the standard arm of the bridge, but the circuit capacitance there is 10,000 $\mu\mu\text{f}$, and the effect of the introduced admittance is for practical purposes negligible. Across the resistance arm R_A , there is also produced an effective negative capacitance. This serves partially to neutralize the real capacitance that exists across this resistance arm and to this extent improves further the accuracy of the circuit. Across the fourth arm B , the introduced capacitance is positive and would act to produce an error in

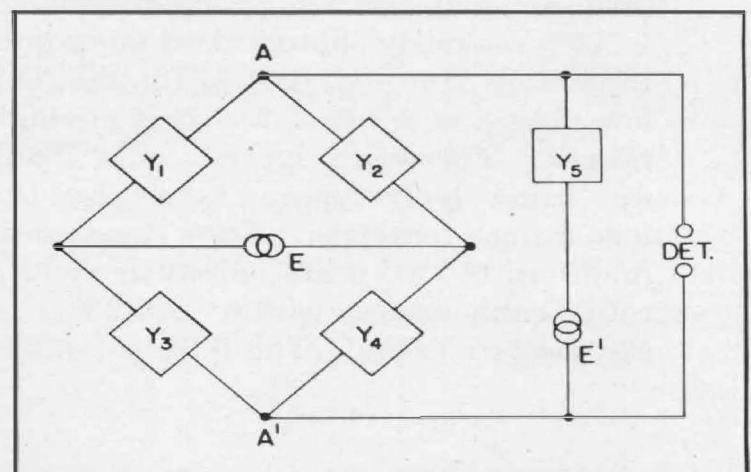

dissipation factor; but, as has been pointed out previously, capacitance is required across this arm to neutralize the losses in the standard capacitor. Therefore, in three of the four bridge arms, the effect of the added circuit is beneficial and in the fourth arm it is negligible.

The compensating circuit is effective for leakage through the bridge transformer and extraneous pickup in the amplifier to the extent that these can be represented by a voltage acting through a fixed impedance to the amplifier input. All of the extraneous effects together with the deliberately introduced voltage and admittance can be combined and represented as in Figure 6.

The equations as written have been in terms of voltage impressed on the bridge circuit, i.e., we have assumed a zero-impedance generator. Actually, of course, the magnitude and phase of the voltage impressed on the bridge change as the bridge arms are manipulated, thus making the compensation less effective. However, the shift of phase and magnitude is not significant except when the capacitance being measured is so large that the zero effects and the stray pickups are inconsequential.

Circuit Elements

Several of the components used in the bridge, in order to realize the accuracy and the direct-reading features, are a little unusual and are briefly described.

As previously noted, two standard capacitors are used, 0.01 μf for the four low ranges and 1.0 μf for the four high ranges. These are special units made up using polystyrene tape for the insulating material. They are each made up of two units paired to yield a total capacitance within $\pm 0.25\%$ of the desired value. The 0.01 μf unit is

mounted in a low-loss phenolic case as used for TYPE 505 Capacitors. The elements making up the 1.0 μf unit are hermetically sealed in cylindrical metal containers of the type commonly used for electrolytic capacitors. Special heat treatment, aging, and impregnation result in a standard of unusually high leakage resistance and low dielectric losses.

Two rheostats (one for each standard capacitor) are used to balance the dissipation factor and are ganged to a common shaft. Each rheostat winding consists of two tapered sections with the resistances of these sections so chosen that the resulting scale permits precise readings at low values of dissipation factor while at the same time retaining the convenience of having the entire range on a single scale. The scale is pre-engraved and four adjustable shunt resistors are provided, one across each section of each rheostat to bring the actual resistance into agreement with the value required by the scale.

In some applications, as for instance in measuring many electrolytic capacitors in the range 1000–10,000 μf , dissipation factors in excess of 30% are encountered. For these values, provision is made in the bridge for switching into the standard arm additional fixed resistors which extend the range to 60%.

The variable resistor R_A , by means of which the capacitance balance is obtained, is the same unit that has been used previously in thousands of General Radio impedance and capacitance bridges. It is a tapered rheostat having a total resistance of approximately 11,000 ohms with the taper so chosen that the scale of the dial is essentially logarithmic. An adjusting plate and cam are built into the unit, which permits an adjustment of the position



of the arm with respect to the dial at several points. As adjusted at the factory, the resistance in kilohms corresponds to the dial reading within $\pm 0.5\%$ over the main decade from 1.0 to 10.

Applications

This new bridge is suitable for use in the electric power industry for the testing, in the shop, of the dissipation factor of bushings and insulators and of the insulation of electrical equipment in general. In making measurements on such large, unshielded structures, voltages may be induced electrostatically which will shift the balance of the bridge. A switch is provided which permits reversing the test voltage with respect to the interfering voltage. The correct capacitance and dissipation factor can be computed from the two sets of readings taken for the two positions of the switch. In most cases the calculation consists merely of taking the arithmetic average of the direct and reverse readings.

In addition to its uses for the testing of insulators and of components, the TYPE 1611-A Capacitance Bridge should find wide application in chemical and plastics laboratories for measuring the dissipation factor and dielectric constant of both solid and liquid dielectric materials. The accuracy of dissipation-factor reading is adequate for all but extremely low-loss materials such as polystyrene, mica, and good electrical grade ceramics. Even for these materials, the dielectric constant can be evaluated accurately. It should be noted that the usefulness of electrical tests of this kind is not limited to insulating materials. Increasing use is being found for electrical measurements on materials destined for uses other than electrical. Product control and the checking of batch-to-batch uniformity of material on the basis of electrical constants is one application that shows increasing promise of usefulness.

—IVAN G. EASTON

SPECIFICATIONS

Capacitance Range: 0 to 11,000 μf , covered by eight multiplier steps and an approximately logarithmic, direct-reading dial.

Dissipation-Factor Range: 0 to 60% (at 60 cycles), covered by a dial having an approximately logarithmic scale with a range of 30%, and a switch that adds a fixed value of 30%.

Capacitance Accuracy: $\pm(1\% + 1 \mu\text{f})$ over the entire range of the bridge.

Dissipation Factor Accuracy: $\pm(2\%$ of dial reading $+ 0.05\%$ dissipation factor). Power Factor = $\frac{D}{\sqrt{1 + D^2}}$, where D = dissipation factor.

Sensitivity: The sensitivity is such that any capacitance in the range 100 μf to 10,000 μf can be balanced to a precision of at least 0.1%.

Temperature and Humidity Effects: The readings of the bridge are unaffected by temperature and humidity variations over the range of room conditions normally encountered (65°F to 95°F , 0 to 90% RH).

A-C Voltage Applied to Capacitance under Test: The voltage impressed on the unknown capacitance varies from a maximum of approximately 125 volts at 100 μf to less than 3 volts at

10,000 μf . The circuit is so arranged that a maximum of one volt-ampere of reactive power is delivered to the sample.

Polarizing Voltage: Terminals are provided for connecting an external d-c polarizing voltage. The maximum voltage that should be impressed is 500 volts.

One of the terminals is grounded so that any a-c operated power supply with grounded output can be used. The terminal capacitances of the power supply do not affect the bridge circuit.

Power Supply Voltage: 105 to 125 (or 210 to 250) volts, 60 cycles.

Power Input: 15 watts.

Accessories Supplied: Line connector cord.

Mounting: Portable carrying case of luggage-type construction. Case is completely shielded to insure freedom from electrostatic pickup.

Vacuum Tubes: One each 6X5-GT, 6SJ7, and 6U5. All are supplied.

Net Weight: 30½ pounds.

Dimensions: (Width) 14½ x (depth) 16 x (height) 10 inches, overall, including cover and handles.

Type	Code Word	Price
1611-A Capacitance Test Bridge	FORUM	\$375.00



MISCELLANY

VACATION — During the weeks of July 26 and August 2 most of our employees will be vacationing. Manufacturing departments will be closed, and other departments will be manned by a skeleton staff. Every effort will be made to take care of urgent business, but repairs cannot be made, except in hardship cases. Our Service Department requests that shipments of material to be repaired be either scheduled to reach us well before this vacation period or delayed until afterward.

TECHNICAL PAPER — "Evaluation of Hysteresis Core Loss by Power Equations," by Horatio W. Lamson, at the 1948 Annual Meeting of the American Society for Testing Materials, Detroit, June 22.

RECENT VISITORS to our plant and laboratories include —

J. L. Tora, Instructor in Electrical Engineering, I. C. A. I., Madrid; Jose M. Rubiato, Assistant Professor, University of Madrid; Eugenio Méndez, Instructor, E. S. I. M. E., of Mexico, D. F.; and P. R. Desikochar, Engineer, All-India Radio, Bangalore.

THE General Radio EXPERIMENTER is mailed without charge each month to engineers, scientists, technicians, and others interested in communication-frequency measurement and control problems. When sending requests for subscriptions and address-change notices, please supply the following information: name, company address, type of business company is engaged in, and title or position of individual.

GENERAL RADIO COMPANY

275 MASSACHUSETTS AVENUE

CAMBRIDGE 39

MASSACHUSETTS

TELEPHONE: TROWBRIDGE 4400

BRANCH ENGINEERING OFFICES

NEW YORK 6, NEW YORK
90 WEST STREET
TEL.—WORTH 2-5837

LOS ANGELES 38, CALIFORNIA
950 NORTH HIGHLAND AVENUE
TEL.—HOLLYWOOD 6201

CHICAGO 5, ILLINOIS
920 SOUTH MICHIGAN AVENUE
TEL.—WABASH 3820