

THE

# General Radio EXPERIMENTER

VOLUME XXII No. 2 and No. 3

JULY-AUGUST, 1947

Copyright, 1947, General Radio Company, Cambridge, Mass., U. S. A.

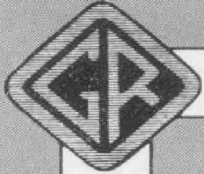

ELECTRICAL MEASUREMENTS AND THEIR INDUSTRIAL APPLICATIONS

## A COUNTING-RATE METER FOR RADIOACTIVITY MEASUREMENTS

*Also*  
**IN THIS ISSUE**  
*Page*  
 THE NEW ELECTRICAL  
 UNITS ..... 7

**THE TYPE 1500-A** Counting-Rate Meter is the first General Radio instrument developed specifically for the comparatively new, but rapidly growing, field of nuclear physics. Fundamentally, it is a frequency meter that indicates, in counts per minute, the rate at which nuclear transformations occur in a radioactive material.

In 1940 General Radio engineers, in cooperation with interested physicists at the Massachusetts Institute of Technology, designed an improved counting-rate meter.<sup>1</sup> Several such instruments were used on war projects, including a blood preservation program that ultimately "saved more lives than were snuffed out at Hiroshima and Nagasaki."<sup>2</sup> The design used in the **TYPE 1500-A** Counting-Rate Meter<sup>3</sup> is essentially the same, except that certain instabilities inherent in the original design have been eliminated in the present circuit arrangement.

The instrument is direct reading and covers the range from 5 to

<sup>1</sup>A. F. Kip, A. G. Bousquet, R. D. Evans, W. N. Tuttle, *Review of Scientific Instruments*, Vol. 17, No. 9, 323-333, Sept., 1946.

<sup>2</sup>J. G. Gibson II and R. D. Evans, *Technology Review*, Vol. 49, No. 2, Dec., 1946.

<sup>3</sup>A. G. Bousquet, "Radioactivity Meter for Nuclear Research," *Electronic Industries*, Sept., 1946.

Figure 1 Panel view of the Type 1500-A Counting-Rate Meter with counter tube plugged in.

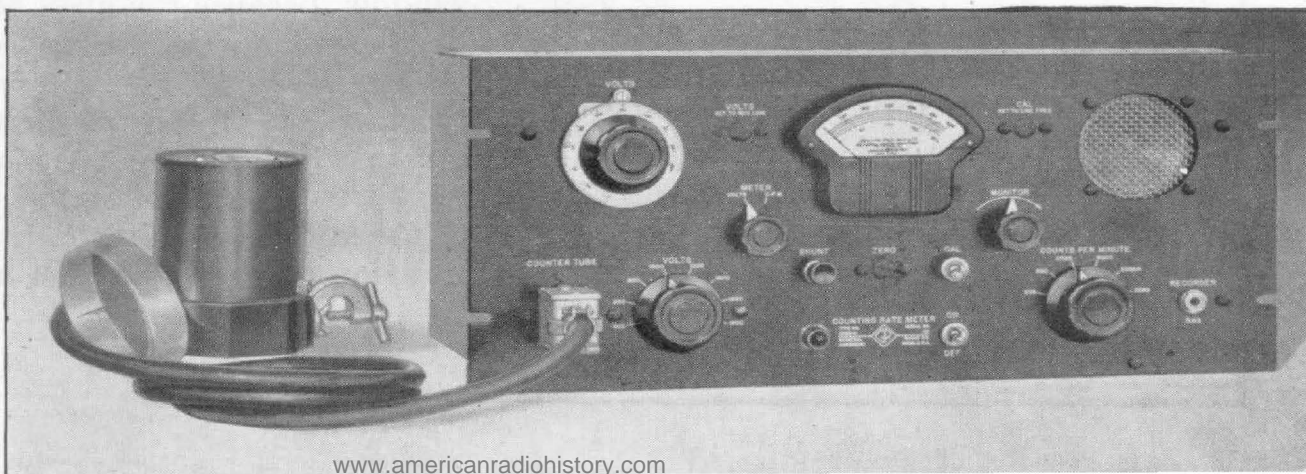

20,000 counts per minute. It includes an aural monitor, a regulated, adjustable high-voltage supply (400-2000 volts), and a quenching circuit to permit the use of either a "self-quenching" or a "non-self-quenching" Geiger-Mueller counter. The equipment is notable for its ease of operation. A major feature is provision for operating a 5-ma pen-and-ink recorder, such as the Esterline-Angus Model AW Graphic Instrument. Consequently, while data are being accumulated, the presence of an operator is not required. Results can be interpreted later from the permanent record.

The Geiger-Mueller counter tube that actuates the frequency-meter circuit is mounted, with its quenching circuit, in a probe at the end of a four-foot cable. For easy interchangeability and short leads, the instrument is designed primarily for use with a counter that has a four-prong tube base. Other designs of counters can be used, however, since connections to the socket can easily be made. Three plug-in type counter tubes are now available for use with this instrument: the TYPE 1500-P2 Beta-Ray Counter, the Sylvania GB-302 Beta-Ray Counter, and the General Radio TYPE 1500-P3 Gamma-Ray Counter.

Figure 2. Characteristic response curve of a Geiger-Mueller counter.

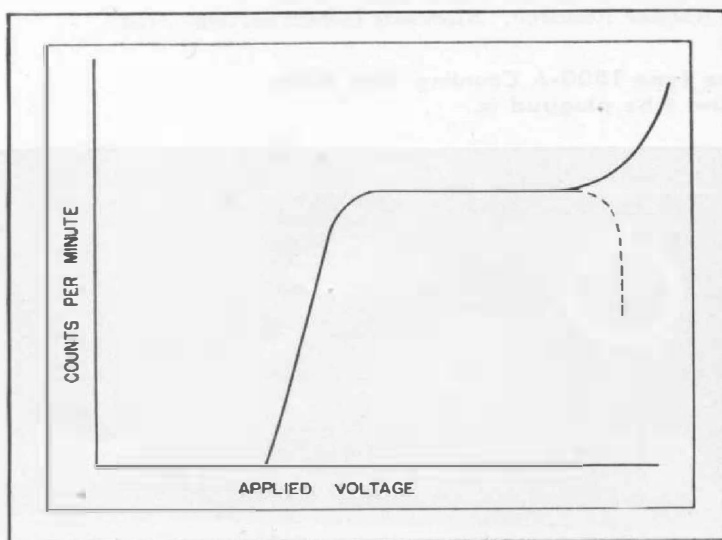

## HOW COUNTERS OPERATE

The operating characteristics of Geiger-Mueller counter tubes differ markedly from those of other tubes familiar to the electronics engineer. Since these characteristics determine the nature of the associated circuits, a more-or-less detailed knowledge of them is necessary as an introduction to the circuit description of the counting-rate meter.

Atoms undergoing nuclear transformation radiate either particles, quanta of energy, or both. The radiation may consist of the high-speed positrons or electrons of beta radiation, alpha particles, gamma rays, X-rays, or neutrons. The radiation is detected by its primary or secondary ionizing effect on the gas in the Geiger-Mueller counter, which consists of a cylindrical metal cathode and a coaxial wire anode enclosed in a gas-filled chamber.

When the counter is designed primarily for detecting beta particles, the coaxial anode is supported at one end of the counter and a very thin "window" is placed at the other end to allow the beta particles to enter without too great a loss from absorption. The ratio of particles absorbed to the total is determined by the window density. In the TYPE 1500-P2 Beta-Ray Counter the window is of 1-mil (0.001-inch) aluminum-alloy foil (about 7 milligrams per square centimeter). Beta particles ionize the gas directly by collision.

Counters designed for detecting gamma radiation and fast neutrons need no window, because the glass envelope and the cathode are to a large degree transparent to these rays. Gamma rays, or photons, are flashes of electromagnetic energy which eject photo electrons from the surface of the countertube cathode in the same way that light causes the emission of electrons from a photo-sen-



sitive surface. Soft gamma rays (X-rays) are absorbed by the gas in the counter, and ionization takes place because of the absorption process. Fast neutrons ionize the gas directly. Cosmic rays are also detected with either the gamma-ray or the beta counter.

These two conventional types of counter are not efficient detectors of alpha particles and slow neutrons. For the counting of alpha particles, an ionization chamber is ordinarily used. Counters for slow neutrons use a boron-trifluoride gas, with which the neutrons react to produce alpha particles, which, in turn, ionize the gas. These and other specialized types of counters can be easily connected to the counting-rate meter.

### QUENCHING

When sufficient voltage is applied to the Geiger-Mueller-counter electrodes, the electron from the ionized atom is attracted to the anode and in its migration collides with other atoms of the gas and causes further ionization. As a result, there is an avalanche of electrons, which lowers the potential of the anode. This change in potential of the anode is detected by the rest of the circuit, and

used as a measure of the radiation resulting from a nuclear transformation.

The positive ions travel relatively slowly to the cathode, where they may eventually cause the emission of secondary electrons. These, in turn, would be attracted to the anode and cause multiple or spurious discharges if proper precautions were not taken. In self-quenching counters a small amount of polyatomic vapor with high electron affinity is introduced into the counter. This vapor absorbs the secondary electrons, and the discharge is quenched. In non-self-quenching counters the external circuit is designed to maintain the anode potential at the low level long enough to allow the complete neutralization of the positive ions, and the discharge is quenched.

In self-quenching counters some of the molecules of the quenching vapor break down to less complex molecules each time a discharge is quenched. The life of this type of counter is consequently a function of the number of "counts" detected. It is usually about  $5 \times 10^8$  counts, which corresponds to a three months' life at about eight hours per day operating at 10,000 counts per minute. The non-self-quenching counter

Figure 3. Functional schematic circuit diagram of the Type 1500-A Counting-Rate Meter.

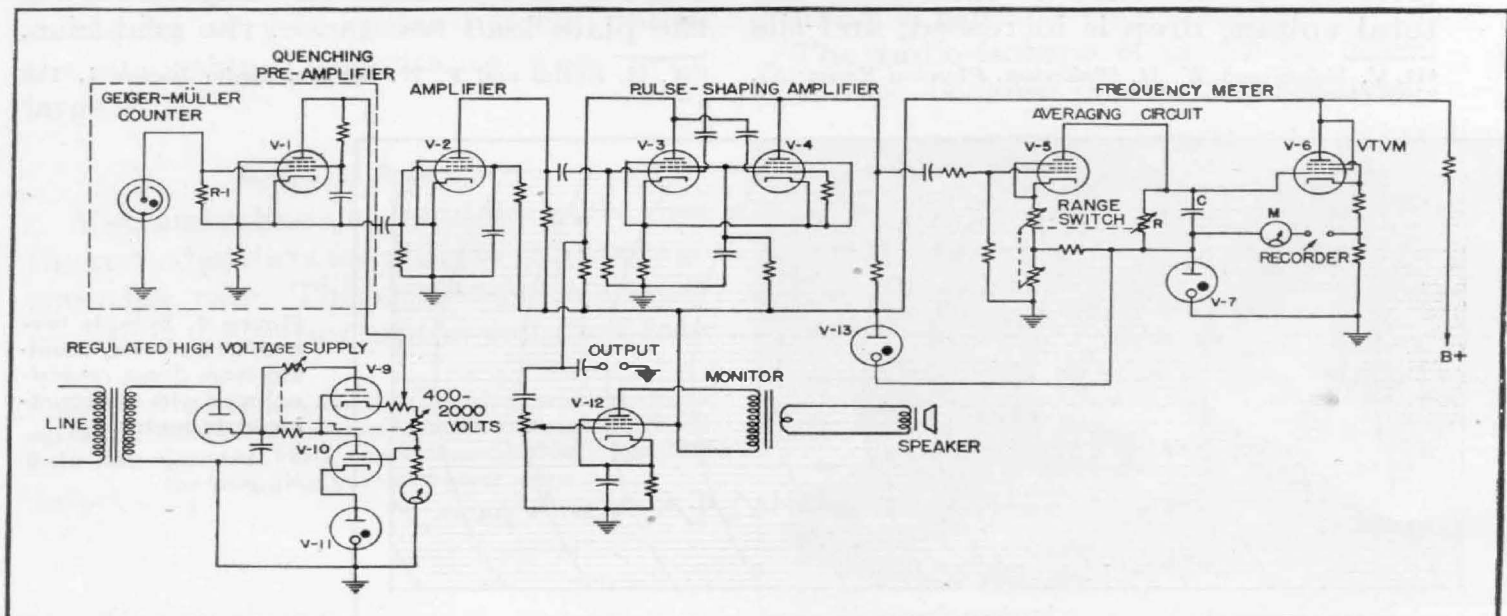



is more reliable over long periods and is less affected by temperature and over-voltage.

The characteristic curve of Figure 2 shows the counter tube response as the applied voltage is varied. The discharge is properly quenched, and the response is quite constant over a fairly wide plateau for both types of counters. When the voltage is excessive, the quenching action is inadequate, and the counter will go into an uncontrolled discharge that is either intermittent as indicated by the rising characteristic due to spurious counts, or continuous as shown by the drooping characteristic with eventual abrupt failure in response.

The TYPE 1500-A Counting-Rate Meter operates with either type of counter. A quenching circuit is included, but does not impair the operation of self-quenching counters.

**CIRCUIT DETAILS**

As shown in Figure 3, the quenching circuit of the TYPE 1500-A Counting-Rate Meter is a modified Neher-Pickering circuit.<sup>4</sup> The vacuum tube V-1 normally operates at zero bias, but, when a counter discharge occurs, the voltage drop in the resistor R-1 causes the tube to operate at cut-off, and, since the impedance of the tube is increased, the total voltage drop is increased, and the

voltage at the counter is maintained at a lower level for the time necessary to quench the counter discharge.

The resultant voltage pulses appearing at the cathode of V-1 are amplified and applied to a modified Eccles-Jordan pulse-shaping circuit<sup>5</sup> whose output pulses depend only for their time distribution on the input pulses. The positive output pulses are all identical in shape and magnitude, and when they are applied to the grid of the next tube, V-5, which is normally biased below cut-off, they cause corresponding plate current pulses to flow through the load resistor, R. A d-c voltage proportional to the average pulse rate is thus built up across the capacitor, C. For pulses spaced equally in time, the plate load voltage will assume a constant average value, but if the pulses are distributed randomly with time the voltage will fluctuate widely about the average value. The capacitor, C, smooths out these fluctuations, and its size is chosen to give a good compromise between speed of response and degree of smoothing. This capacitor, designed and built by the General Radio Company, is wound with polystyrene tape to avoid dielectric polarization errors that other dielectric materials would introduce. The ranges are varied by simultaneously changing the plate load resistance, the grid bias,

<sup>4</sup>H. V. Neher and W. H. Pickering, *Physical Review* 53, 316L (1938).

<sup>5</sup>W. H. Eccles and F. W. Jordan, *Radio Review* 1, 143 (1919).

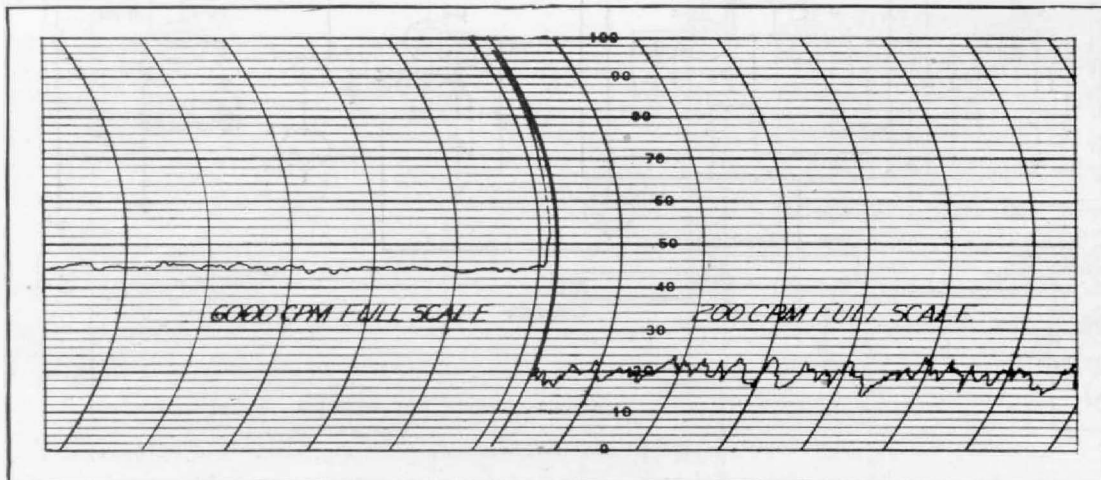

Figure 4. Sample records of beta-ray counting from 5-ma recorder, used with the counting-rate meter.



and the amount of degeneration in the cathode circuit of V-5. A d-c vacuum-tube voltmeter across the R-C plate load of the averaging circuit indicates the pulse rate and is calibrated in counts per minute. The full-scale ranges are 200, 600, 2,000, 6,000, and 20,000 counts per minute.

### RECORDER

An Esterline-Angus 5-ma pen-and-ink recorder can be plugged in directly in series with the panel meter, and, since the calibration is linear, the recorder deflection will be proportional to the counting rate. While a recorder is not essential, its use is recommended, since, because nuclear transformations occur at random intervals, a definite time is required to obtain a minimum error in the determination of the average counting rate, no matter what the measuring method is.

A sample of the results to be expected is shown in Figure 4. The unevenness of the trace is an indication of the random time distribution of nuclear transformations. The lower the counts per minute, the more irregular the trace will be, percentage-wise, for a given running speed of the paper. Obviously, if the counting rate were only one per minute and random in time distribution, the trace would be very irregular indeed, unless the smoothing capacitance were very large.

### ACCURACY

A straight line can be drawn through the recorded data to indicate the average counting rate. The accuracy to be expected is a function of the counting rate

and of the recording time. After equilibrium has been established, a recording time of about one minute is required at 50 counts per minute to yield an error of less than 2 per cent in the interpretation of the results, whereas a few seconds' observation will be sufficient at the high counting rates (greater than 2000 counts per minute) to bring the error in the interpretation of the results down to a negligible value. In addition to this statistical error, the accuracy of the indicated result can be no greater than the full-scale accuracy of the meter itself. This metering accuracy is better than 3 per cent of full scale.

### APPLICATIONS

Prewar radioactivity applications were numerous. During the war nuclear physics was utilized in many projects, including blood preservation, goiter diagnosis, radiotherapy, and, of course, the atomic bomb. Physicists, chemists, geologists, biologists, botanists are now applying the many newly available radio-isotopes to their particular problems. Metallurgy, power engineering, crystallography, agriculture, oil surveying, glass and plastics manufacturing, combustion engineering design, ore assaying, and turbulence research are but a few more of the fields where radioactivity is proving very useful.

The radio-isotope is useful for these purposes, because it has the same elec-

Figure 5. View of pre-amplifier and quenching circuit assembly with cover removed to show Type 1500-P2 Beta-Ray Counter. Note the convenient arrangement for plugging in the counter tube.

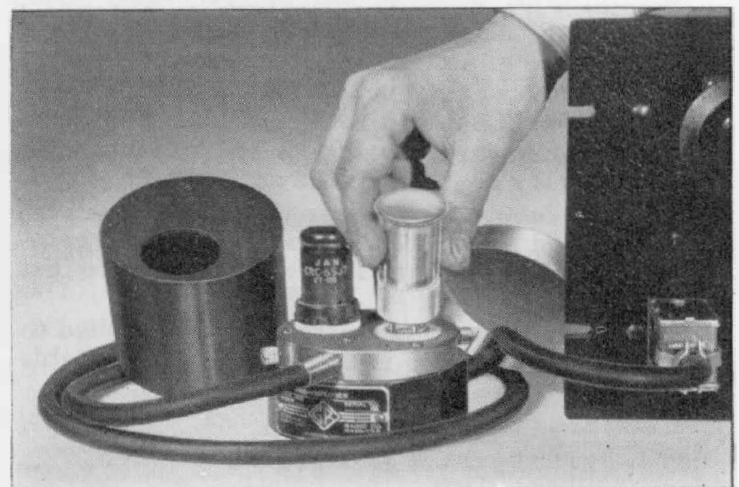



tron system as its stable counterpart and consequently exhibits the same chemical properties. Typical uses of these isotopes are as "tagged" elements in chemical reactions and in tracer work, and as radiation sources in radiotherapy. In these broad fields of application, it is fortunate that many of the artificially radioactive isotopes are relatively short-lived since after each experiment the slate is automatically wiped clean. Iodine 131 has a half-life of eight days; phosphorus 32, fourteen days. Carbon 14, however, is very long-lived: 5100 years elapse before its activity is halved. Some 85 radio-isotopes are now available from the Oak Ridge Isotopes Branch. Over 450 isotopes have been produced by the various particle accelerators such as the cyclotron, synchrotron, and betatron.

Biologists have learned that cells where growth is rapid are particularly sensitive to irradiation, and that cells exhibit specific absorption. Dosage of food or of medicine for a specific organ can consequently be studied readily by the tracer technique, and irradiation can be selectively applied internally. For example, radio-therapeutic doses can be administered that will get radioactive strontium to a bone tumor or radioactive iodine to the thyroid gland

when local irradiation is needed. Tracer technique is proving useful in studying such problems as how light can form sugars photosynthetically from carbon dioxide and water.

The geologist has gleaned information on the age of the earth from deposits of helium and pitchblende. The mineralogist has tabulated the relative abundance of the naturally radioactive isotopes and is using the information for the ready analysis of the potassium content of salt deposits from various regions. The metallurgist is compiling valuable data concerning case-hardening, welding, alloying by tracer methods.

Cosmic radiation, plentiful at all times, provides a continuous supply of very high energy radiation. Even so, the mutations attributed to cosmic radiation are not sufficiently well controlled for the zoologist, who concentrates a radioactive beam on the *Drosophila* fruit fly to fathom in a short time the secrets of evolution that are otherwise disclosed only after eons of cosmic irradiation of the now human species.

Further applications of nuclear physics are daily being found. They are closely dependent on the use of electronic measuring and counting instruments.

— A. G. BOUSQUET

## SPECIFICATIONS

**Range:** Full scale values of 200, 600, 2000, 6000, and 20,000 counts per minute are provided. The minimum rate that can be read on the meter scale is 5 counts per minute.

**Accuracy:** The instrument has been calibrated with a generator of equally-spaced pulses to yield an accuracy of  $\pm 3\%$  of full scale on all ranges.

**Counter Tube:** Counter is not included and must be ordered separately. Both beta-ray and gamma-ray counters are available. See price list below.

**Counter Circuit Voltage:** The voltage applied to the counter circuit is continuously adjustable

from 400 to 2000 volts. The value of the voltage is read from an eight-position switch and a calibrated dial which covers the 200-volt interval between switch points. Means are provided for standardizing the voltage so that the accuracy of the voltage readings is within  $\pm 3\%$  of the actual value. The power supply is well regulated so that line-voltage fluctuations do not cause changes in the high-voltage supply.

**Output:** The output of the trigger circuit is available at rear terminals. The 400- to 2000-volt variable high-voltage supply is also available at terminals at the rear of the instrument.



**Aural Monitor:** A small loudspeaker is mounted on the panel for use as an aural monitor. A control, with an off position, is provided for adjusting the volume.

**Power Supply:** 105 to 125 volts, 50 to 60 cycles. By a simple change in connections on the power transformer, a 210- to 250-volt line can be used.

**Power Input:** 60 watts.

**Vacuum Tubes:**

- |             |                |
|-------------|----------------|
| 5 — 6SJ7    | 2 — 6J5        |
| 1 — 6AG7    | 1 — 6C6        |
| 1 — 6X5GT/G | 2 — 991        |
| 1 — 2X2/879 | 2 — 0C3/VR-105 |

Type		Code Word	Price
1500-A	Counting Rate Meter*	WORRY	\$495.00
1500-P2	Beta-Ray Counter	WORRYBETAR	55.00
1500-P3	Gamma-Ray Counter	WORRYGAMMA	54.00

\*U. S. Patent No. 2,374,248.

## THE NEW ELECTRICAL UNITS

On January 1, 1948, the National Bureau of Standards, in cooperation with similar organizations in other countries, will introduce revised values of the units of electricity and light. This change was scheduled to go into effect in 1940, but the project was delayed by the war.

The electrical units of the present "international" system will be superseded by those of the "absolute" system, derived from the fundamental mechanical units of mass, length, and time by use of the accepted principles of electromagnetism, with the value of the permeability of space taken as unity in the centimeter-gram-second system or as  $10^{-7}$  in the meter-kilogram-second system. Actually, all of the common electrical units fall into the m-k-s system. This revision constitutes a return to the basic principles, always recognized as desirable, of having the electrical units consistent with the fundamental mechanical units.

The international units now in use were originally intended to be exact multiples of the units of the centimeter-

**Accessories Supplied:** Power connection cable; plug for recorder connection; preamplifier assembly, with connection cable.

**Accessories Required:** Geiger Mueller counter tube. See price list below.

**Mounting:** The instrument is shipped with walnut end frames for table mounting. Relay-rack mounting is possible by removing the end frames.

**Dimensions:** Panel, 19 x 8 1/4 inches; depth behind panel, 13 inches.

**Net Weight:** 38 1/2 pounds, including preamplifier.

gram-second system, but the units were defined independently. The ampere, the ohm, and the volt were defined by reference to three physical standards — the silver voltameter, a specified column of mercury, and the Clark standard cell. The original definitions were not sufficiently specific to give the precision that eventually came to be required, with the result that the units as used differed slightly from the c-g-s system while, because of the independent definitions, the units did not satisfy Ohm's law.

This condition was recognized some forty years ago, and the units were redefined. The ohm as defined by the mercury column was retained, as was the ampere in terms of deposits of silver. The magnitude of the international volt was changed to make it consistent with the ampere and the ohm in the relationship  $I = \frac{E}{R}$ . This revision achieved consistency among the units, but did not correct the difference between the international system and the c-g-s system. The revision of the units to accomplish this correction was agreed upon as de-





sirable by many scientific and engineering societies as early as twenty years ago and, since that time, plans for the change have been going forward. Absolute measurements of resistance and current have been made in various countries, and the results correlated by measurements made on the various national standards at the International Bureau of Weights and Measures.

At its meeting in Paris in October, 1946, the International Committee on Weights and Measures adopted the following relations between the mean international units and the new absolute units:

- 1 mean international ohm = 1.00049 abs. ohms
  - 1 mean international volt = 1.00034 abs. volts
- The mean international units are the averages of units as maintained by six countries (France, Germany, Great Britain, Japan, U. S. S. R., and U. S. A.), all of which took part in this work before the war. Each country's units differ slightly from the average, and the conversion factors for the United States will be as follows:
- 1 international ohm = 1.000495 abs. ohms
  - 1 international volt = 1.00033 abs. volts
  - 1 international ampere = 0.999835 abs. ampere
  - 1 international henry = 1.000495 abs. henrys

- 1 international farad = 0.999505 abs. farad
- 1 international watt = 1.000165 abs. watts

To convert the values of existing standards to the new units, the present values should be multiplied by these factors.

It will be seen that for resistance, inductance, and capacitance, the magnitude of the change is 0.05 per cent. This difference is large enough so that it cannot be neglected in calibrations guaranteed to 0.1 per cent or 0.25 per cent. Consequently, during the second half of 1947, our calibrations of resistors, capacitors, and inductors will gradually be changed to the new absolute units. During 1947, the National Bureau of Standards is specifying calibrations in both systems of units, and our own standards, which are checked periodically by the Bureau, are being revalued in the new units.

All instruments listed in Catalog K, will, in the future, be calibrated in the new units and when so calibrated will carry the word "absolute" or the abbreviation "abs." on their panels. All new instruments not as yet cataloged, will be calibrated in the new units, without specific statement on their panels.

— R. F. FIELD

***THE General Radio EXPERIMENTER is mailed without charge each month to engineers, scientists, technicians, and others interested in communication-frequency measurement and control problems. When sending requests for subscriptions and address-change notices, please supply the following information: name, company address, type of business company is engaged in, and title or position of individual.***

**GENERAL RADIO COMPANY**

275 MASSACHUSETTS AVENUE

CAMBRIDGE 39

MASSACHUSETTS

TELEPHONE: TROWBRIDGE 4400

**BRANCH ENGINEERING OFFICES**

NEW YORK 6, NEW YORK  
90 WEST STREET  
TEL.—WORTH 2-5837

LOS ANGELES 38, CALIFORNIA  
950 NORTH HIGHLAND AVENUE  
TEL.—HOLLYWOOD 6201

CHICAGO 5, ILLINOIS  
920 SOUTH MICHIGAN AVENUE  
TEL.—WABASH 3820