

The GENERAL RADIO EXPERIMENTER

VOL. VIII. No. 12



MAY, 1934

ELECTRICAL COMMUNICATIONS TECHNIQUE AND ITS APPLICATIONS IN ALLIED FIELDS

HOW DIALS ARE MADE

PERHAPS the most important feature of any dial for instrument use is the scale, which must have uniform, clear, clean-cut divisions, accurately spaced. The scale may be made by several possible methods, one of which is stamping. The disadvantage of this method is that, after a few hundred scales have been produced, the die shows appreciable wear. The resulting wide scale markings plus the high initial cost of the die make this method not as satisfactory as other processes.

If a very accurate scale having a large number of fine, closely-spaced graduations is desired, the scale can be individually engraved on an automatic self-indexing engraving machine.* The precision scale thus produced has very uniform, accurately-spaced divisions, but the cost is necessarily high because of the labor involved.

Where extreme accuracy is not required and where good appearance and low cost must be combined, dials made

by the "photo-etching" method are eminently satisfactory. As the name implies, the process is one in which photolithography and chemical etching are combined. Photolithography is used to print an etch-resisting coating over the surface of the dial, after which the unprotected metal is eaten away in a chemical bath.

The process is well adapted to the economical production of identical scales on a quantity basis. The details can best be understood by tracing the manufacture of a single dial, but it will be obvious that many dials can be handled as readily as a single unit.

The first essential step in the process is the making of a complete and accurate black-and-white drawing, usually to a large scale so that the subsequent reduction to actual size will minimize any small irregularities. The reduction is done in a camera having a lens carefully corrected for optical distortion, and the resulting negative is then used to make a transparent contact "positive," having black (opaque) lines on a white (transparent) background—a dial-sized replica of the original drawing.

*It is by this process that the scales on the General Radio TYPES 704 and 706 Precision Dials are made.



The self-indexing engraving machine which rules the scales on TYPE 704 and TYPE 706 Precision Dials

A plate of grained lithographic zinc of uniform surface is then coated with a light-sensitive solution of bichromate and albumen and carefully dried on a rotating disc at the proper temperature to produce an emulsion of uniform thickness. The zinc plate is then held in close contact with the transparent positive and exposed to intense illumination.

The exposed zinc plate is washed with a safe-etch solution and water and rolled up with lithographic ink in order to "develop" the image. The result is a zinc printing plate or "master"

General Radio precision dials have individually engraved scales: A TYPE 706 Dial with a TYPE 519-A Dial Lens

which takes ink wherever the positive allowed the light to strike and repels ink in the unexposed portions. The plate is placed on a flat-bed offset press which transfers the inked impression onto a rubber-covered roller or "blanket" and from that onto the actual piece of polished nickel-silver dial metal.*

After the ink has been transferred to the dial metal, the plate is then ready for etching. First it is dusted with a combination of asphaltum or dragon's blood powder and French chalk which adheres to the ink (background). The excess material is removed either by a small, soft brush or by compressed air.

*The process up to this point is simply photolithography, used for printing maps, calendars, circus posters, etc., except that the impression is made on paper or cloth instead of dial metal. Many of the small-sized General Radio instruction booklets are made by this process from type-written originals.—EDITOR.

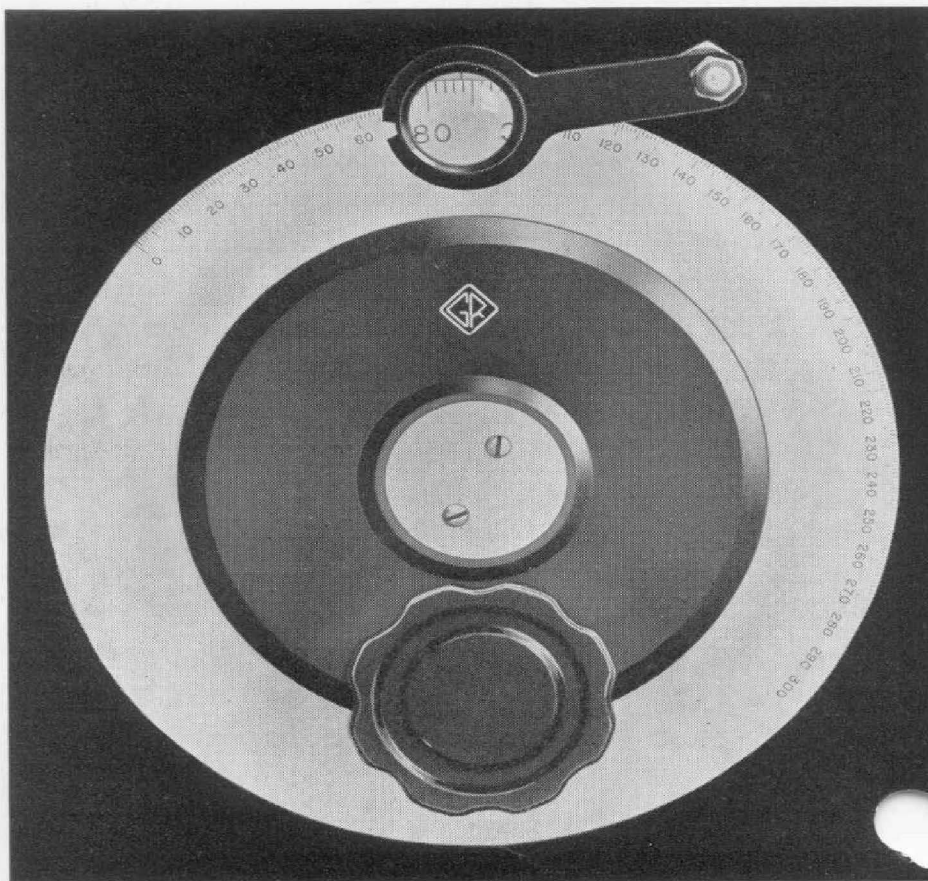

The ink and the powder are fused and hardened by heating the sheet of metal either in an oven or over an open flame. The heating of the plate forms the acid-resist material which covers the metal where it is not desired to etch. It is especially important in the manufacture of dial scales not to apply too much heat which may distort the metal. The back of the plate is covered with asphaltum paint or other resisting material.

The etching process is purely chemical. The dial metal is hung in a solution of perchloride of iron crystals and muriatic acid which is kept constantly agitated to hasten the etching. Fifteen or twenty minutes is the usual time required for etching, but this varies with the strength of the acid, the metal of which the dials are being made, and the depth it is desired to etch. After etching is completed, the metal is dipped in cleaning chemicals and rinsed in water.

The plate, with the scales and figures etched and the background still covered with the acid-resist material, is then sprayed over the entire surface with black lacquer. After this is dry, the dial plate is immersed in a solvent

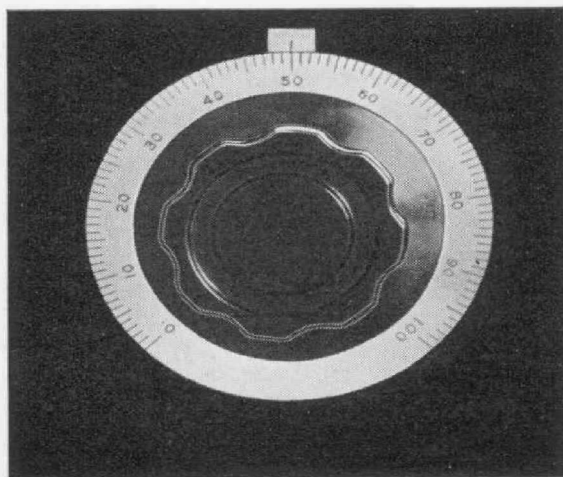

The etching process described in the accompanying article is used to make the scales on dials like this one: A TYPE 710-B, 2 $\frac{3}{4}$ -inch dial

which removes the acid-resist material, with its coating of lacquer, leaving the polished dial metal exposed. The lacquer in the etched portions is unaffected by the solvent.

The individual dial scales are cut out and mounted on a spindle and the circular-grain finish is applied with fine emery and polishing wheels. The scales are then turned down to the exact diameter and sprayed with clear lacquer to preserve the finish. The completed dial scales are then mounted on their respective bakelite knobs and placed in stock. —MYRON T. SMITH

A NEW SWEEP CIRCUIT FOR THE ELECTRON OSCILLOGRAPH

LAST June the General Radio Company introduced the TYPE 635-A Electron Oscillograph, a small and portable type of cathode-ray oscillograph which at that time was an innovation. Although the standard TYPE 506-A Bedell Sweep Circuit* can, of course, be used to provide a linear time

axis for this oscillograph, there has been considerable demand for a lower-priced unit designed mainly for use with the portable electron oscillograph.

The laboratories of the General Radio Company have, accordingly, developed a new sweep circuit known as the TYPE 655-A Bedell Sweep Circuit*

* U. S. Patent 1,707,594.



FIGURE 1. This new instrument supplies a controlled linear sweep for the General Radio TYPE 635 Electron Oscillograph

for Electron Oscillograph and intended mainly for use with the TYPE 635-A and TYPE 635-B Electron Oscillographs.* Since the new sweep circuit was intended primarily for use with a single general type of oscillograph, it has been possible to simplify it appreciably without sacrificing any of the important features which have made the TYPE 506-A Bedell Sweep Circuit so popular.

In the first place, since the sensitivity of the TYPE 635 Electron Oscillographs is not adjustable, the sweep circuit may be designed to give a definite length of sweep. For the same reason, the direct polarizing voltage which centers the pattern on the oscillograph screen may be left fixed. These factors alone make possible the elimination of two con-

*The TYPE 635-B Electron Oscillograph is a modified form of the original TYPE 635-A Electron Oscillograph and uses the RCA-906 cathode-ray oscillograph tube or its equivalent.

trols. It has also been possible to provide fixed synchronizing circuits in this sweep circuit which will allow control of the sweeping action for any voltage sufficient to produce a satisfactory deflection on the cathode-ray tube.

It will, accordingly, be seen that the only characteristic of the operation of the sweep circuit which must be adjustable is the frequency. In the TYPE 655-A Bedell Sweep Circuit this is accomplished by a single knob covering ranges from 30 to 300 cycles per second and from 300 to 3000 cycles per second. A double-pole switch is provided for shifting the range.

This sweeping frequency range of 30 to 3000 cycles per second was determined after a careful investigation of the uses to which cathode-ray oscillographs are generally put. We have found that the most common use for oscillographs with sweep circuits is the

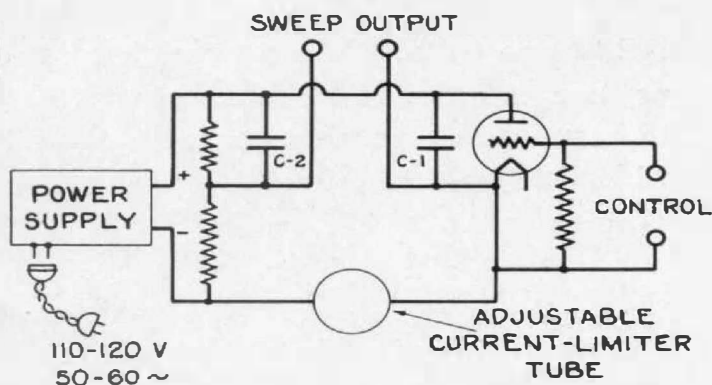

FIGURE 2. Schematic diagram for the TYPE 655-A Bedell Sweep Circuit

observation of audio-frequency waveforms in the range from 30 to 15,000 cycles per second. Another common use of the oscillograph is for observing modulated radio-frequency waves, the modulation frequency being within this same audio range and, accordingly, requiring the same sweeping frequency as for a corresponding audio-frequency waveform.

The TYPE 655-A Bedell Sweep Circuit allows observation of frequencies down to 30 cycles per second. At its upper sweeping limit of 3000 cycles per second a 15,000-cycle wave will be seen with five complete cycles across the cathode-ray screen. Similarly, 18,000- and 21,000-cycle waves, which are above the limit of audibility for most people, may be seen on the oscillograph with six and seven complete cycles, respectively, spread across the screen. For the few special occasions when extremely low sweeping frequencies are required, an external condenser may be used to extend the range.

We have also found that portable oscillographs of this type are frequently used for 60-cycle work. With the range of the TYPE 655-A Bedell Sweep Circuit either one or two cycles of a 60-

cycle wave may be seen on the oscillograph.

The principle of operation of the TYPE 655-A Bedell Sweep Circuit is similar to that of the popular TYPE 506-A Bedell Sweep Circuit. Figure 2 shows the general arrangement. The condenser C-1 is charged at a constant current which is determined by the setting of the adjustable current limiter. When the voltage across this condenser reaches the breakdown value for the 885-type discharge tube, the tube flashes and discharges the condenser. The cycle then repeats itself. By introducing a small voltage of the frequency of the observed wave into the grid circuit of the discharge tube, the sweeping action may be made to synchronize with the observed wave, thus giving a steady pattern on the oscillograph screen which may be inspected carefully or photographed.

Of course, the arrangement shown in Figure 2 is not the complete wiring diagram for the instrument, which necessarily includes arrangements for providing the proper grid bias on the discharge tube, for controlling the current limiting action, etc. The sweep circuit also contains a complete a-c operated power-supply unit and a filter for minimizing interference transmitted back from the discharge tube through the control circuits.

The operation of the TYPE 655-A Bedell Sweep Circuit is extremely simple. The terminal posts are so arranged on the panel that it is merely necessary to connect together corresponding posts on the oscillograph and on the sweep circuit. Only the single large frequency knob and its associated two-range switch need be adjusted, and

this adjustment involves only turning the knob or setting the switch so that the desired pattern is seen on the screen. The panel of the instrument is engraved directly in approximate sweeping frequency, making it possible to set the instrument quickly to any desired value or to determine the approximate frequency of an observed waveform.

The instrument is supplied complete with a set of tubes which consist of one 885-type tube, one 58-type tube, and

one 80-type tube. No batteries whatsoever are required for the operation. The instrument operates on any source of 110-120 volts, 50-60 cycles alternating current. —H. H. SCOTT

[The price of the new TYPE 655-A Bedell Sweep Circuit described in the foregoing article is \$60 including tubes. The new TYPE 635-B Electron Oscillograph, also mentioned in the article, is priced at \$80 including tubes. The sweep circuit was developed by Mr. Scott; the new oscillograph by E. Karplus.—EDITOR]



PHOTOGRAPHY OF TRANSIENTS WITH A CATHODE-RAY OSCILLOGRAPH*

TAKING satisfactory photographs of stationary recurrent patterns appearing on the fluorescent screen of a modern cathode-ray oscillograph is a fairly simple matter inasmuch as the exposure time need be limited only by the observer's ability to maintain a stable pattern. When, however, he must record transient phenomena in which the spot sweeps only once across the screen, the "speed" of both lens and sensitive emulsion must be suited to the brilliancy of the spot and to the speed with which it moves across the screen. There is a maximum spot velocity beyond which a given spot brilliancy and a given lens-emulsion combination will fail to produce a usable record. The experimental determination of this limiting velocity is a fundamental consideration.

The simple method of measuring the limiting velocity described here is be-

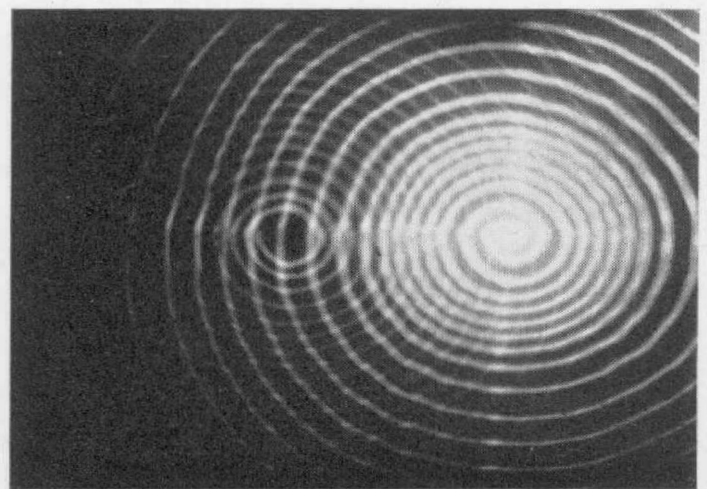

Two maximum-velocity spirals of the type described in the accompanying article. Each was taken with a different accelerating voltage on the tube

lieved to have been the original idea of Eduard Karplus, Engineer, of the General Radio Company. It depends for its

*Reprinted from the "Notes on Electron Tubes and Circuits" section in the April, 1934, issue of *Electronics*. Copyright, 1934, McGraw-Hill Publishing Co.

operation on the fact that, when both pairs of deflecting plates are excited by equal a-c voltages of the same frequency but 90° out of phase, the circular (Lissajou) figure appears. This is traced out by the fluorescent spot which sweeps around the circle once for each cycle of the applied a-c voltage. Obviously, the velocity of the spot is proportional to the diameter of the circle, so that if its diameter is progressively increased, there will be a point beyond which a single passage of the spot fails to make an impression on the emulsion. A record of this type is shown in which the diameter of the circle was rapidly widened during the exposure so that the spot executed a spiral.

A convenient circuit for making the test, using the 115-volt, 60-cycle line is shown. The two quadrature voltages are taken off across C and R_1 , R_1 being adjustable so that the voltages can be made equal. R_2 is a voltage divider across the line. By adjusting it, the diameter of the circular pattern can be changed at will.

The test exposure is made by decreasing R_2 until the circle is a mere spot, then the camera shutter is opened and R_2 quickly increased to a maximum. This produces a corresponding rapid increase in the diameter of the circle traced by the moving spot, which results in the spiral shown. The velocity at any point on the spiral is given by the relation $v = 2\pi rf$, where r is the distance from the center to the point in question, f is the frequency in cycles

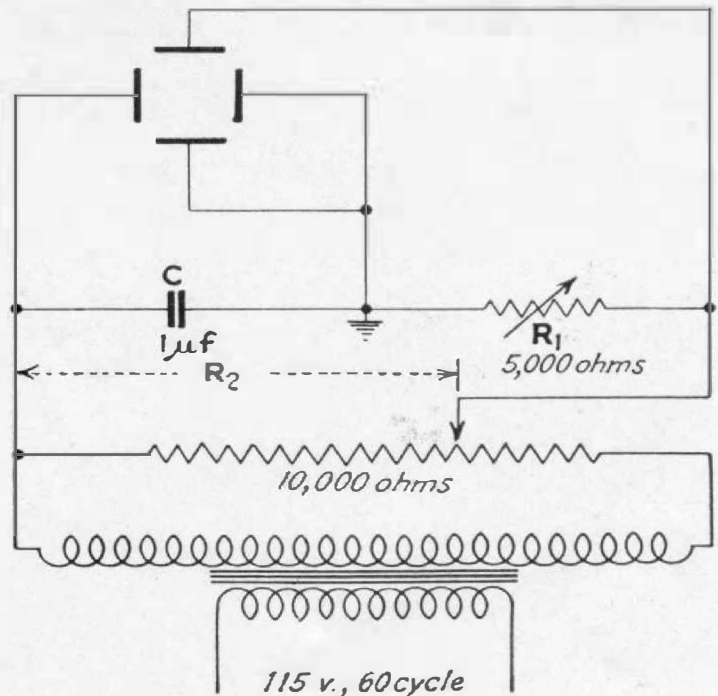

Circuit for measuring the maximum velocity of oscillograph spot that a given lens-emulsion combination will record

per second, and v is the velocity in linear units per second, the unit being the same as that chosen to measure r . The use of the 60-cycle line will usually give a sufficiently wide range of test velocities for cathode-ray oscillograph tubes now generally available, but greater velocities can, of course, be obtained by increasing the test frequency.

Because of the ease with which this test can be carried out, experimenters working with transients that approach the limiting velocity can easily test out each new package of emulsion stock in the same way that photographers who are trying for perfection often determine by trial the exposure required by the particular batch of printing paper being used. —JOHN D. CRAWFORD

CROSLEY'S W L W



RATED at 500,000 F-R-C, gold-standard watts, WLW's new plant at Mason, Ohio, has just gone on the air full time as the world's largest.

The *Experimenter* reverses the emphasis given these two photographs in the popular press to call attention to General Radio frequency monitors in the right-hand relay rack in the fore-

ground. At the top is the frequency-deviation indicator which operates from one of the three standard-frequency oscillators below it. Three oscillators are required because this same control room is used for WSAI and W8XAL, two other Crosley channels.

Joseph A. Chambers is the Technical Supervisor.



THE GENERAL RADIO COMPANY mails the *Experimenter*, without charge, each month to engineers, scientists, and others interested in communication-frequency measurement and control problems. Please send requests for subscriptions and address-change notices to the



GENERAL RADIO COMPANY

30 State Street - Cambridge A, Massachusetts

PRINTED
IN
U.S.A.