

Transformerless Power Supplies (continued)

point in the circuit is at line potential. When the negative return is thus common to the chassis (and metal cabinet), there is grave danger of electric shock and fire.

Every possible precaution should be taken in the design of equipment to be powered by transformerless supplies to guard against shock to the operator and accidental grounding of the power line. It is urged that the bridge circuit of Figure 10 be used whenever possible in test instruments, in preference to the other circuits.

When experimenting with transformerless voltage multiplier circuits, such as the tripler, quadrupler, and higher-order multipliers, the operator must bear in mind that the circuit will most certainly deliver a voltage equal to several times the line peak, when supplying a light load. The extreme compactness of the transformerless multiplier, together with the conspicuous absence of heavy iron-core components usually associated with dangerous high-voltage equipment, tends to reduce the operator's alertness to the high-voltage danger.

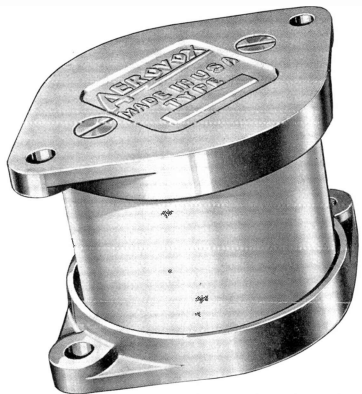

Yesterday, "SPECIAL"

today, "STANDARD"

● Until recently the mica stack-mounting type and other extra-heavy-duty transmitting capacitors in mica, oil-filled, electrolytic and paper plug-ins and other types, were definitely "special" or made to order. Previous prices reflected the custom-built angle.

Aerovox, however, has made these extra-heavy-duty transmitting capacitors standard items in regular production as listed in the Aerovox Transmitting Capacitor Catalog. Such capacitors are now available to you at new and reasonable prices for your initial equipment, alterations or maintenance. Therefore, before placing your next order, be sure to check AEROVOX standard types and prices!

Ask for DATA . . .

● If you are engaged in designing, building or maintaining radio or electronic equipment using extra-heavy-duty capacitors, write on business letterhead for your copy of the Aerovox Transmitting Capacitor Catalog. Submit that capacitance problem for engineering collaboration, recommendations, specifications, quotations.

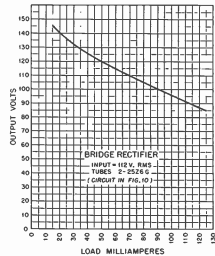

FIG. 11

For the benefit of designers of transformerless power supplies, a tube table has been supplied in Part 1 of this article, listing the principal characteristics of all the tubes designed especially for transformerless operation. In addition to the rectifiers listed in this table, the following types combine a transformerless rectifier in the same envelope with an output amplifier: 12A7, 25A7-G, 25A7-GT, 32L7-GT, 70L7-GT, 117L7-GT, 117M7-GT, 117N7-GT, and 117P7-GT. The heater voltages of these tubes are evident from the first part of the type number.

NEW BEDFORD, MASS., U. S. A.
Sales Offices in All Principal Cities

AEROVOX
CORPORATION

In Canada
AEROVOX GAMBON
Hamilton, Ont.
EXPORT: 180 Spadina, N. W. 11
CAN. MAIL REG. NO. 12345



VOL. 14, NO. 3

MARCH, 1942

60c per year in U.S.A.
60c per year in Canada

Transformerless Power Supplies

PART II

By the Engineering Department, Aerovox Corporation

VOLTAGE TRIPLER CIRCUITS

EXTENDING the principle of voltage multiplication still further, we show two voltage tripler circuits as Figures 4 and 5. The circuit of Figure 4 is essentially that of a conventional half-wave doubler and half-wave rectifier in series.

How this circuit supplies d.c. at three times the line voltage may be explained in this manner: When the lower side of the supply line is positive, diodes V_1 and V_3 pass current, charging capacitors C_1 and C_2 to the line peak less the drops in the two tubes. When the input cycle reverses, the voltage across C_1 combines with the peak line voltage and charges C_3 through V_1 to this total value. The

voltage across C_3 is then very nearly equal to twice the line peak, while that across C_2 is very nearly equal to the line peak.

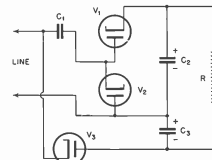

CAPACITOR PEAK VOLTAGES
 C_1, C_2 LINE VOLTAGE $\times 1.41$
 C_3 LINE VOLTAGE $\times 2.82$
VOLTAGE TRIPLER

FIG. 4

These two capacitors discharge in series, affording their combined voltage drops. Thus, the voltage presented to the load resistance R is the sum of the voltages appearing across C_2 and C_3 —approximately three times the line peak.

In the tripler circuit, the ripple frequency corresponds to that of the line because of the asymmetry of the arrangement. Filtering procedure is therefore the same as for the simple half-wave transformerless circuit.

In the second voltage tripler circuit, shown in Figure 5, the four diodes of the two tubes are connected in a full-wave doubler-full-wave rectifier circuit in a manner somewhat similar to the foregoing circuit. Constants given in

AEROVOX PRODUCTS ARE BUILT BETTER

Printed in U. S. A.

Copyright 1942 by Aerovox Corporation

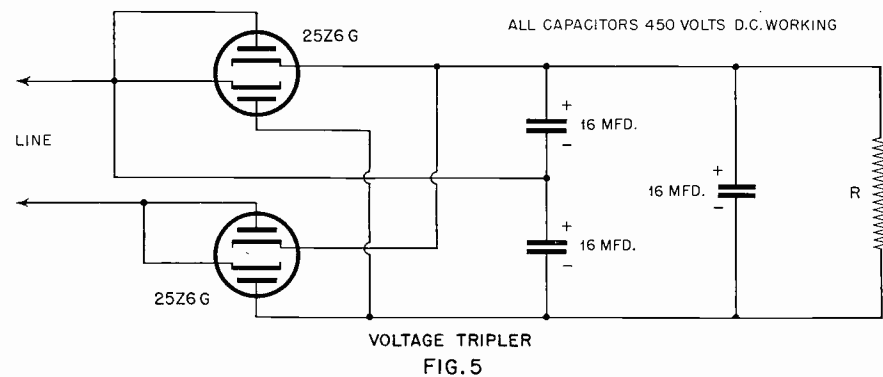

the diagram are those employed by the editors in an experimental set-up. An output voltage-load current curve for this circuit is given in Figure 6.

VOLTAGE QUADRUPLER CIRCUIT

When two half-wave doublers are operated in series, as in Figure 7, a practical voltage quadrupler circuit is obtained. Operation of this circuit is explained in this manner: When the lower side of the supply line is positive, diode V_2 passes current, charging capacitor C_1 to a voltage equal to the line peak less the drop in V_2 .

When the line polarity reverses, the plate of V_1 is positive at a potential equal to the voltage across C_1 plus the line peak. V_1 passes current and the capacitor C_2 is charged to a voltage equal very nearly to twice the line peak.

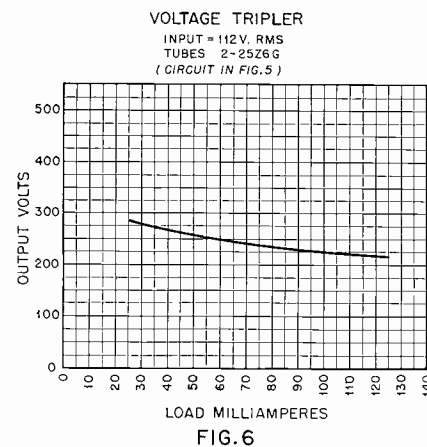

Now, when the upper side of the line swings positive, C_2 is also charged very nearly to the line peak by current passed by V_3 . And when the lower side of the line swings positive, C_1 is also charged by current through V_4 to a voltage equal to the line peak plus the voltage across C_2 less the tube drop. Thus, the voltages across C_3 and C_4 are each equal to a little less than twice the peak line voltage.

The final result of this action is that the total voltage presented to the load R is the sum of the voltages across C_3 and C_4 —approximately four times the line peak for low values of load current. Hence the term *voltage quadrupler*.

C_1 and C_2 must be capable of handling the line peak; C_3 and C_4 twice that voltage. The quadrupler circuit is symmetrical and accordingly easy to filter.

Constants given in the quadrupler circuit in Figure 8 are those arrived at in an experimental setup by the editors. Performance of this practical circuit is shown by the output voltage-load current curve, Figure 9.

The quadrupler is not the ultimate in voltage-multiplying circuits. The principle may be even further extended. Practical circuits have been set up to multiply the line voltage by six, eight, and ten without transformers. However, the voltage regulation of these chain-type circuits is poor, and the heater-cathode potential at the high-voltage end of the

string will greatly exceed the maximum value permissible for a given tube, giving rise to immediate or at least premature breakdown.

It is seen from the foregoing explanations that in all transformerless voltage-multiplying circuits capacitors are separately charged and then permitted to discharge in series. The operation of switching these capacitors alternately into charging and discharging positions is performed automatically by the tubes.

BRIDGE RECTIFIER CIRCUIT

A simple transformerless bridge rectifier circuit is shown in Figure 10. This unit is a full-wave supply which does not give a "hot" connection back to the power line. The bridge rectifier is particularly advantageous for supplying power to certain test instruments, such as oscillators and vacuum-tube voltmeters, which do not require high plate voltages but demand compactness and economy. Another distinguishing feature of the bridge rectifier circuit is that the two tubes operate in series and a line voltage of twice the ordinary value may be used when desired, provided that the filter capacitors can withstand the higher output voltage.

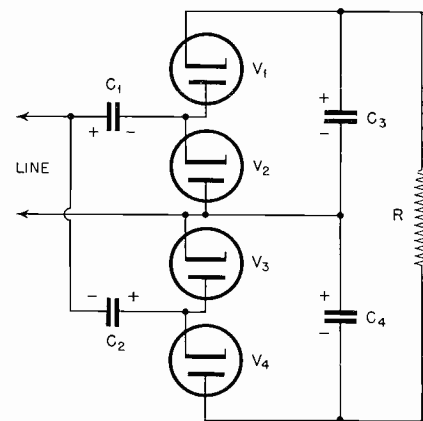

CAPACITOR PEAK VOLTAGES
 C_1, C_2 LINE VOLTAGE X 1.41
 C_3, C_4 LINE VOLTAGE X 2.82
AN OUTPUT FILTER CAPACITOR WOULD BE RATED AT
LINE VOLTAGE X 5.64
VOLTAGE QUADRUPLER
FIG. 7

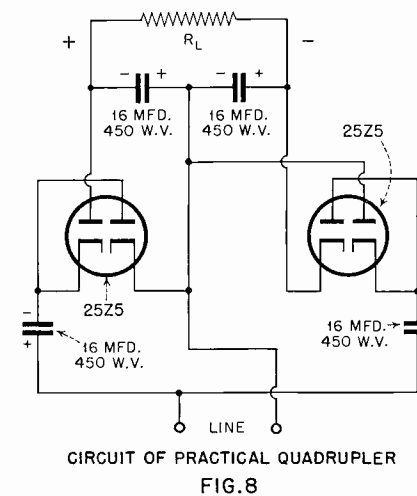

CIRCUIT OF PRACTICAL QUADRUPLER
FIG. 8

Operation of the bridge circuit takes place in the following manner: When the upper side of the power line is positive, diode 1 of the upper tube passes current, charging the input filter capacitor, through diode 4 of the lower tube, to the line peak voltage less the drop through the two diodes.

Upon reversal of the line polarity, diode 3 of the lower tube and diode 2 of the upper tube pass current, again charging the input capacitor. Thus, both halves of the supply-voltage cycle are utilized and full-wave rectification thereby secured. The ripple voltage across the capacitor is at twice the line frequency and therefore may be filtered as easily as the output of a full-wave rectifier. The input capacitor, like the same unit in the half-wave rectifier circuit, need be capable of withstanding only the line peak voltage.

Constants given in the circuit diagram are those employed by the editors in a test circuit, and the curve of Figure 11 is the output voltage-load current characteristic obtained with those values.

CONSTRUCTION AND OPERATION NOTES

Transformerless power supply circuits do not generally require mechanical and electrical treatment different from that common to other types of power units, except that care

must be taken to ventilate these units. The tubes designed for this service have high-voltage heaters and their envelopes radiate considerable heat. The high-capacitance electrolytic capacitors may soon become damaged from exposure to the heat. At the same time, the powered unit might have its operation impaired by the heat generated by the power supply. It is strongly recommended that the transformerless power supply be located near ample air vents judiciously placed in the instrument or receiver case.

In any of the circuits described in the foregoing discussions, larger output currents may be obtained by connecting two or more tubes in parallel wherever one tube is shown in the diagram. Voltage regulation may be improved to some degree by the use of larger filter capacitances than those specified, and still further by means of small gaseous voltage regulator tubes, such as types VR75, VR90, VR105, VR150, and 874, used singly or in an appropriate series combination. Rectifier tubes of full-wave separate cathode type of construction may be employed in any of the circuits in which a number of separate diodes is indicated. By doing so, two effective tubes are made available in each envelope, providing compactness and ease of replacement.

The high-voltage heaters of tubes designed principally for transformerless power supplies are connected to the line through a suitable dropping resistor (often built directly into the line cord, in order to remove heat sources from the chassis) or to the other heaters connected in series in the powered circuit. When the series

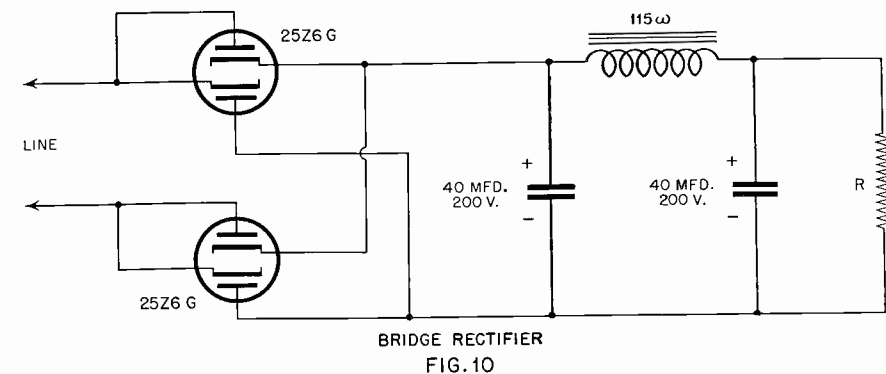

BRIDGE RECTIFIER
FIG. 10

heater arrangement is employed in a radio receiver, the tubes must be placed along the string in a preferred sequence in order to minimize the hum due to heater-cathode leakage. The rectifier tube, being able to withstand the highest value of heater-cathode voltage, is placed first in the series string, closest to the line and farthest from ground. One transformerless supply tube—type 117Z6-GT—has a 117-volt heater that may be connected directly across the a.c. line without a dropping resistor. This tube enables the construction of transformerless power supply units of extreme simplicity and economy.

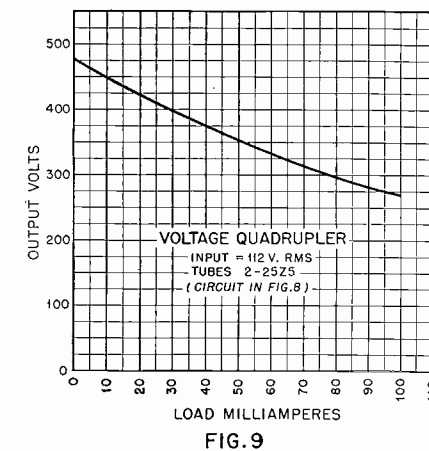

It will be observed from the circuit diagrams in this article that most transformerless power supply circuits provide a dangerous connection back to the power line. Often, in the case of the simple half-wave line rectifier used most frequently in midget radio sets, this "hot" connection is likewise the B-minus point or chassis ground. In such an arrangement, any negative