

Radio Editors of magazines and newspapers are hereby given permission to reprint in whole or in part, with proper credit to the Aerovox Corporation, the contents of this issue of the Aerovox Research Worker.

The AEROVOX

Research Worker

The Aerovox Research Worker is a monthly house organ of the Aerovox Corporation. It is published to bring to the Radio Experimenter and Engineer authoritative, first hand information on condensers and resistances for radio work.

VOL. 11, NO. 3

MARCH, 1939

50c per year in U.S.A.
60c per year in Canada

The Measurement of Motor-Starting Capacitors

By the Engineering Department, Aerovox Corporation

FOR the proper operation of a capacitor type motor during the starting period, the capacitor must maintain its capacity and power factor within fairly close limits. Some motors are more critical than others in the allowable variation in capacity that they will tolerate and still give good starting service. Similarly, an excessively high power factor will reduce the starting torque thus prolonging the starting period. When the starting torque is too low the motor will not come up to speed and disconnect the capacitor. This condition causes a progressive failure of the capacitor as it is on voltage for too long a period. When the motor requires more than 10 to 20 seconds to come up to speed and disconnect the starting circuit, the motor and its starting equipment should be examined for excessive load on the motor and for a defective or improper capacitor. Excessive load on the motor may be due to friction in the bearings. This can be determined by removing the load and turning the motor over by hand. The starting switch in the motor should be examined for wear or damage to make certain the fault is mechanical as capacitor failure is less likely than any other type of failure.

Motor starting capacitors should be tested under actual operating conditions of rated voltage and frequency. In order to determine properly all the capacitor characteristics the capacitor is tested for current and power when rated voltage is impressed across its

terminals. The circuit shown in Figure 1 shows the proper connections for the test.

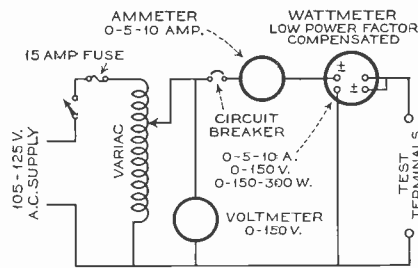

Figure 1

The circuit and the equipment is straight-forward except that a low power factor wattmeter is required since the power losses in a good condenser are very low, although the product of the current and voltage, the apparent power is quite high. For this reason it is desirable to have a low power factor wattmeter the scale of which in watts reads about one fifth of the volt-ampere capacity of the circuit. A circuit breaker having a capacity of 15 amperes is used to protect the meters when a shorted condenser is accidentally connected to the test terminals. If the circuit breaker is used as a switch, it should be of the "trip free" type. This prevents the operator from holding the breaker closed on a short circuit. The variac is necessary as the voltage must

be adjusted to the rated voltage of the condenser.

Two range meters are desirable because of the large variation in capacitors used on standard motors. Such meters are standard or can be readily converted by the use of shunts and multipliers.

To find the capacity and power factor of a capacitor, the voltage is first adjusted to the rated voltage of the unit. The unit may be connected to the test terminals, but the circuit breaker should be open. The circuit breaker is then closed and a final adjustment of voltage is made while simultaneous readings of current and power are taken. The voltage should not be applied to the capacitor for more than 30 seconds. Longer application of voltage may damage the unit. The capacity of the capacitor is then found by multiplying the current by 2650 and dividing by the voltage. This holds for 60 cycles only. The per cent power factor is found by dividing 100 times the power in watts as read on the wattmeter by the products of current times voltage. The chart shown in Figure 2 can be used to simplify the operation.

To find the capacity and power factor of a capacitor from the current, power, and voltage readings, the curves of Chart 2 are used as follows:

A straight edge such as a celluloid triangle is placed on the chart so that it connects the current in amperes on the left hand side of

AEROVOX PRODUCTS ARE BUILT BETTER

the "C" scale with the voltage, as read on the voltmeter, on the left hand side of scale "B". The capacity in microfarads is read from the capacity scale on scale "A". The capacity scale has a range of 30 to 2500 mfd. so that all values of capacity normally found in practice can be determined by this chart.

To find the power factor from the current, voltage and power readings, a line is drawn from the voltage now on the left hand side of scale "A" to the current on the left hand side of scale "C". The point at which the line crosses the "B" scale is marked and a second line is drawn through this point and the power in watts on the power scale which is on the left hand side of scale "A". This scale is also the voltage scale. The line is extended to the right hand side of scale "C" and power factor is read from this scale.

Thus a capacitor that draws 5.2 amperes, 40 watts from a 120 volt 60 cycle line is found to have a capacity of 115 mfd. and a power factor of 6.4%. Using the same capacitor as before, the voltage being 120, the current 5.2 amp. and the power 40 watts; we find that the line connecting the 120 volt point on line "A" and the 5.2 ampere point on the left-hand side of line "C", crosses the line "B" at 624 volt amperes. Now putting the straight-edge so that it connects the 40 watt point on line "A" with the 624 volt ampere point marked on line "B", we find that it crosses the power factor scale, the right-hand scale of line "C", at 6.4 per cent power factor.

If a circuit breaker is not available, the capacitor should first be tested for a short. This can be done in several ways. The easiest method is to test the unit on D.C. if a source is available. The capacitor is connected in series with a 100 watt lamp across a 120 volt D.C. line. The lamp will light to full brilliancy when a shorted unit is connected across the line. A capacitor having high leakage will cause the lamp to glow. This test for leaking has very little meaning as any leakage that will cause a 100 watt lamp to glow is much too great to be tolerated. The 100 watt lamp can be replaced with a 20 watt lamp to give a better indication of leakage. A short can be determined on A.C. with the circuit shown in Figure 3. The neon lamp will light up when a shorted capacitor is tested.

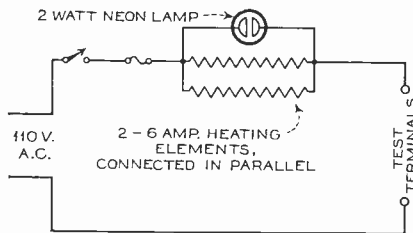

Figure 3

Another method of testing a capacitor for power factor does not require a wattmeter but entails considerably more calculation. The capacitance is found, as before, from the current and voltage readings. To find the power factor, the effective or equivalent series resistance of the capacitor is found by the following method:—The capacitor is connected in the circuit of Figure 4, and a reading of the current and voltage taken with the knife switch open (E_1 and I_1). If the capacitor is not

shorted, the knife switch is closed and another reading of the current and voltage taken (E_2 and I_2). The capacitance is found from the second set of readings. To find the equivalent series resistance use is made of the following equation

$$R_e = \frac{\left(\frac{E_1}{I_1}\right)^2 - \left(\frac{E_2}{I_2}\right)^2 - R^2}{2R} \quad (1)$$

E_1 and I_1 are the readings with the switch open and E_2 and I_2 are the readings with the switch closed.

The power factor of the capacitor is then given by the equation

$$\text{PERCENT P.F.} = \frac{R_e}{\left(\frac{E_2}{I_2}\right)} \times 100 \quad (2)$$

No simple graph or chart can be made for the calculation of the first equation. If R is fixed, a family of curves can be computed and used for a more rapid calculation of the resistance but this does not save much time.

For the average sized motor starting capacitor a resistance of 20 ohms is a satisfactory value. The exact value of the resistance is not necessary as the voltage drop across it can be found. The circuit can be so arranged as shown in Fig. 4, so that by pressing a series of 3 buttons the voltmeter can be connected across the resistor, the condenser and the line in any order desired. The current will be read on the ammeter as before.

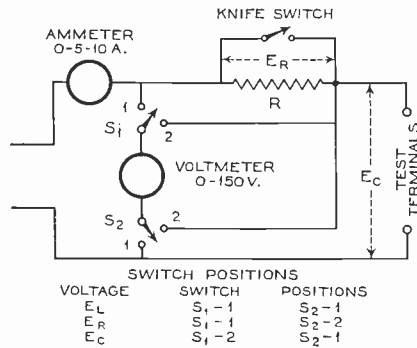

Figure 4

For this set-up the capacity becomes

$$C = 2650 \frac{I_2}{E_2} \quad (3)$$

and the equivalent series resistance is

$$R_e = \frac{\frac{E_1^2 - E_R^2}{I_1^2} - \left(\frac{E_2}{I_2}\right)^2}{2 \frac{E_R}{I_1}} \quad (4)$$

E_1 and I_1 taken with switch open
 E_2 and I_2 taken with switch closed
 E_R is voltage across R .

With this sequence of measurements it is not necessary to make a separate short circuit test as the first reading, with the knife switch open, will be sufficient to indicate a shorted condenser. When a 20 ohm series resistor is used, the current will be equal to the voltage divided by the 20 ohms if the capacitor is short circuited. Thus, if a 150 mfd. capacitor is being tested on a 120 volt line, the ammeter will read 4.5 amperes for a good unit and 6 amperes for a shorted unit. If the unit is found to be good the readings of current and voltage are recorded and the knife switch closed. The readings of current and voltage are again recorded and the computations performed. A sample computation is given below.

$E_1 = 120$ volts $I_1 = 4.0$ amperes
 $E_R = 80$ volts $E_2 = 120$ volts
 $E_C = 85.6$ volts $I_2 = 5.6$ amperes

From the graph of Figure 2, the capacity is found to be 124 mfd. Using the second set of readings, a line is drawn up from the point 5.6, on the C scale, until it crosses the 120 volt line, on B scale, across the graph to the A scale and 124 mfd. is read.

To find the power factor the first and second sets of readings are used.

$$R_e = \frac{\left(\frac{120}{4}\right)^2 - \left(\frac{80}{5.6}\right)^2 - \left(\frac{120}{5.6}\right)^2}{2 \left(\frac{80}{4}\right)}$$

$$= \frac{14400 - 6400 - 14400}{16} = \frac{14400}{31.6}$$

$$= \frac{8000 - 14400}{16} = \frac{14400}{31.6}$$

$$= \frac{500 - 460}{40}$$

$$R_e = \frac{40}{40} = 1.0 \text{ Ohms}$$

The power factor of this condenser is then found from equation (2)

$$\text{PERCENT P.F.} = \frac{R_e \times 100}{\frac{E_2}{I_2}} = \frac{1}{\frac{120}{5.6}} \times 100$$

$$= \frac{1}{21.4} \times 100 = 4.7 \text{ PERCENT}$$



POWER - POWER-FACTOR CHART

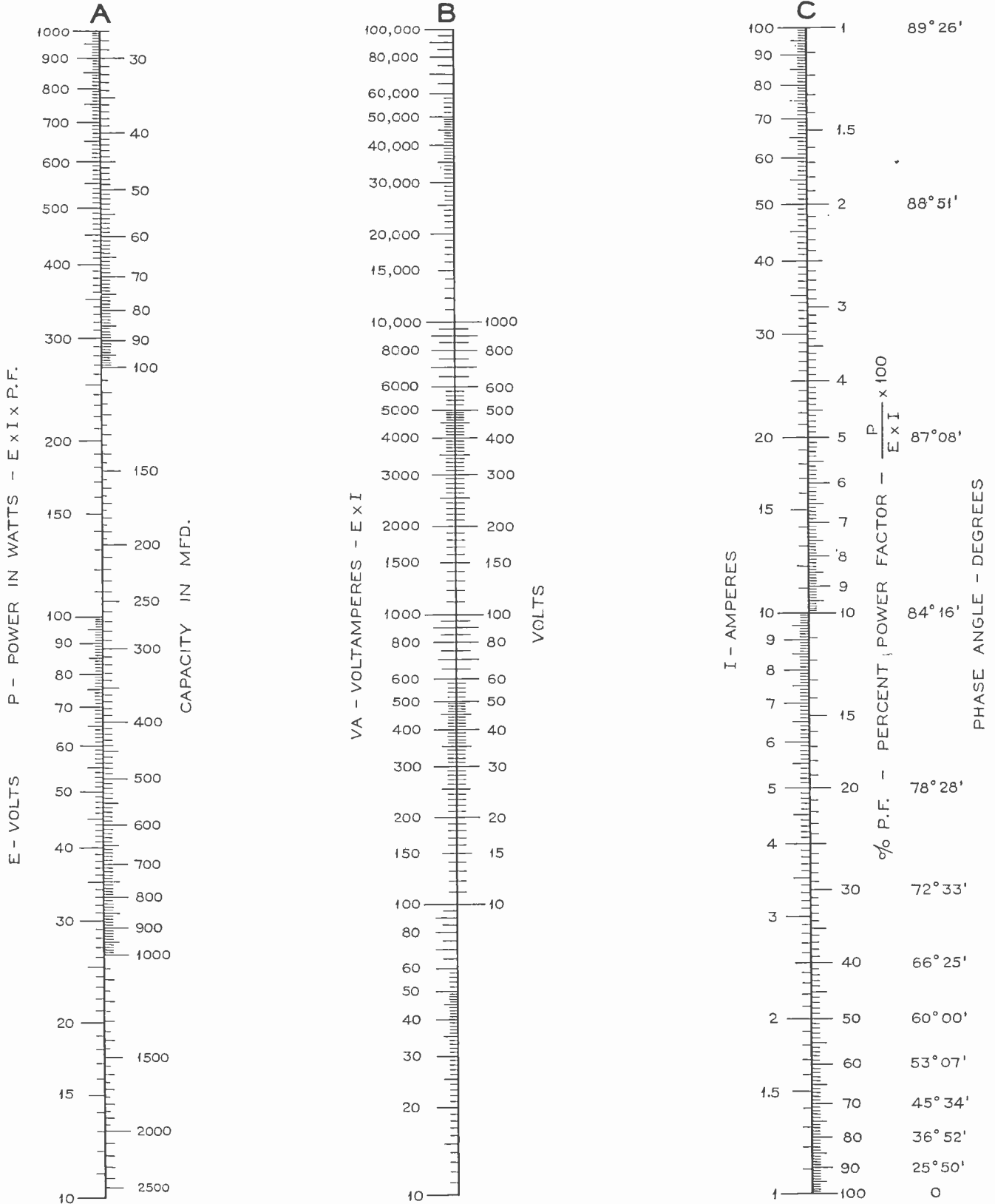
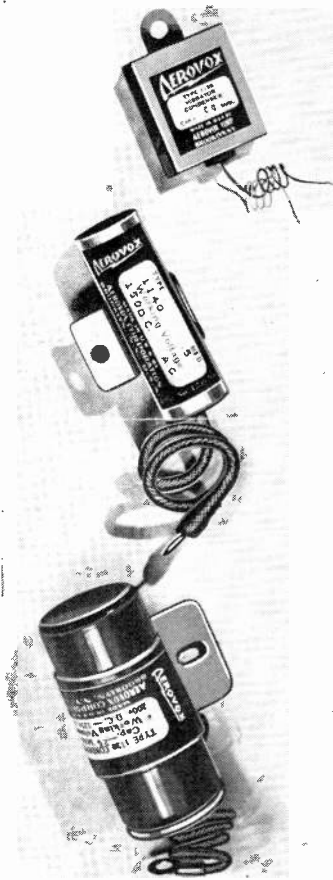

Figure 2

AUTO-RADIO Condensers

• Few applications are more severe than those of auto-radio. First and foremost, the condensers must often withstand the extremes of icy-cold weather and blistering engine heat. Second, vibrations and jolts must be withstood. Third, and mighty important, there must be a really precise application if noise suppression is to be truly achieved. AEROVOX engineers have met these three cardinal requirements. And their auto-radio condensers, as cataloged below, are ready to tell the story of thorough engineering.



Ask for

CATALOG

• Your jobber has the latest catalog featuring these auto-radio condensers, along with all other radio condenser needs.

Ask your jobber for a copy. Or you may write direct to us, if you prefer.

Meanwhile, if you plan to come to the Parts Show in Chicago, be sure to jot down our booth—208 Coulomb Street.



Suppressor Condensers

Type 1120—1.0 Mfd. List Price \$0.75
Type 1140—0.5 Mfd. List Price \$0.50



Dual Section Suppressor Condenser

Type 1141—5-.5 Mfd. List Price \$0.75



Suppressor Condensers for FORDS



FOR 1937 MODELS
Type 1144—Cap. .5 Mfd. List Price \$0.50
FOR 1936 MODELS
Type 1150—Cap. .5 Mfd. List Price \$0.50

Ammeter Condensers



Type	Cap.	List Price
1160	.5	\$0.45
1170	1.0	.65

Dome Light Filter Condenser Type 1180

List Price \$0.80



Oil-Gauge Filter Condenser

Type 1142-0 .25 Mfd.

List Price \$0.50

Oil-Impregnated Vibrator Condensers

List Price Each, Any Capacity \$0.45



Type 1130—One Lead		Type 1131—Two Leads	
Cap.	Cap.	Cap.	Cap.
.007 Mfd.	.04 Mfd.	.007 Mfd.	.01 Mfd.
.01 Mfd.	.05 Mfd.	.01 Mfd.	.02 Mfd.
.02 Mfd.	.06 Mfd.	.02 Mfd.	
.03 Mfd.	.07 Mfd.		

Vibrator Condensers

Type	Cap.	List Price
1135	.01	\$0.60
1135	.5	.65

Tubular Paper Vibrator Condensers



Type 1684—1600 W.V.D.C.			
Cap. Mfd.	List Price	Cap. Mfd.	List Price
.005	\$0.35	.03	\$0.35
.007	.35	.04	.40
.01	.35	.05	.45
.02	.35		

Oil-Impregnated Tubular Vibrator Condensers

Hermetically sealed oil condenser in metal tubes, with an outer cardboard tube as an insulating cover.

Type 1686—1600 W.V.D.C.			
Cap. Mfd.	List Price	Cap. Mfd.	List Price
.005	\$0.35	.01	\$0.40
.006	.35	.02	.40
.007	.40		

Gas-Gauge Filter Condenser

Type 1143-G .05 Mfd. List Price \$0.50



"Hash" Condenser

Type 1122—Cap. .5 Mfd. List Price \$0.40



AEROVOX CORPORATION

New Bedford, Mass.

Sales Offices in All Principal Cities

