

# COMMUNICATIONS



NOVEMBER

★ RADIO ENGINEERING

★ OWI 200-KW BETHANY TRANSMITTERS

★ GRAPHICAL COURSE ALIGNMENT AIDS

★ REPORT ON FCC TELEVISION HEARINGS

★ QUARTER-WAVELENGTH INSULATORS

★ TELEVISION ENGINEERING

1944



# Why AMPEREX

## WATER and AIR COOLED TRANSMITTING and RECTIFYING TUBES

*Of exclusive Amperex design!* These four words, denoting an "Amperextra" reflected in better performance, have been used in a number of instances when describing our products. Of exclusive Amperex design, for example, is the channel support of our transmitting tubes. This feature results in more rigid support of tube elements. Exact inter-element alignment is assured. This, in turn, means absolute freedom from change in characteristics that might ordinarily arise from shock and vibration either in shipment or service.

There are more than 100 different types of **Amperex** tubes for broadcasting, industrial and electro-medical applications. An **Amperex** engineer will gladly assist you with your present or postwar problems.

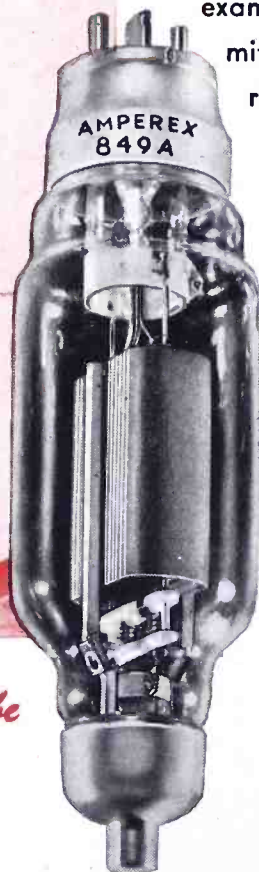

**AMPEREX** . . . *the high performance tube*



*Keep Buying . . .  
Keep Holding . . .  
More War Bonds*

# AMPEREX ELECTRONIC CORPORATION

79 WASHINGTON STREET . . . . . BROOKLYN 1, N. Y.  
Export Division: 13 E. 40th St., New York 16, N. Y., Cables: "Arlab"

# THE 400 SERIES

# Input Transformers

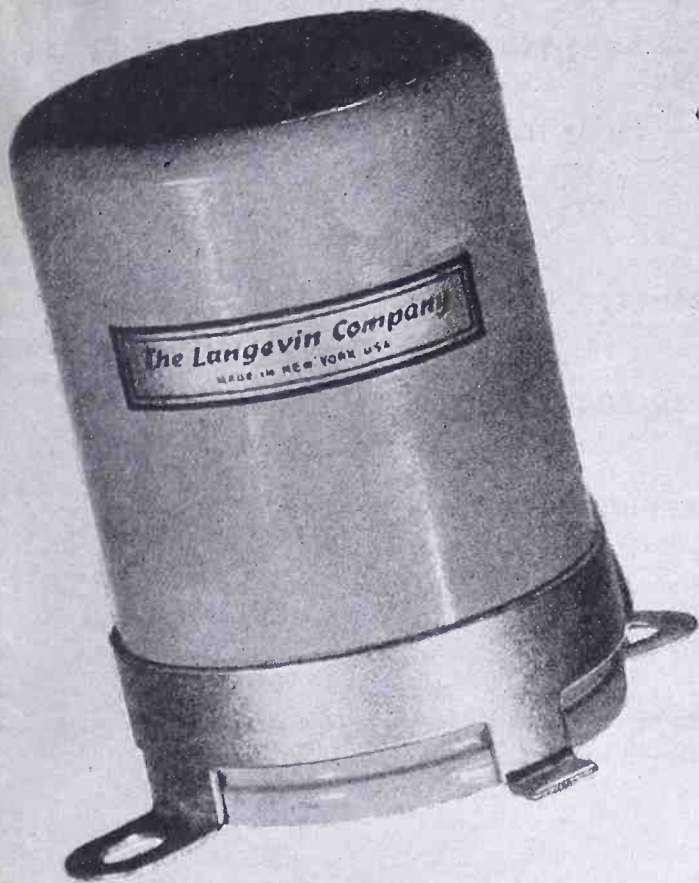

**D**esigned to occupy minimum space with excellent frequency response, the 400 Series Input Transformers are intended for high quality amplifier requirements. Combines high permeability shield with rotatable strap mounting for minimum stray field pick-up. Equipped with 10" Surprenant color-coded leads. 2" center to center mounting, 1 1/2" O.D. x 2 1/4" high. Baked gray enamel finish. Available for immediate delivery.

## TYPE 401-A INPUT TRANSFORMER

30/250/600 ohms to 30,000 ohm secondary center tapped. Maximum operating level +10 V.U. at .001 milliwatt reference level.

## TYPE 400-C BRIDGING INPUT TRANSFORMER

Nominal impedance 600/15,000 ohms to 60,000 ohm secondary. With proper input circuits, input impedance range 0/25,000 ohms. Maximum operating level +10 V.U. at .001 milliwatt reference level.

## TYPE 402-A INPUT TRANSFORMER

Nominal 30/120 ohm primary to 50,000 ohm secondary. Input impedance range 0/250 ohms. Maximum operating level +10 V.U. at .001 milliwatt reference level.

Frequency response characteristics as usually expressed for input transformers of wide frequency response are not complete due to variables in circuit constants. Therefore we have prepared an engineering bulletin illustrating exact operating measurements, which is available upon request.

# The Langevin Company

INCORPORATED

SOUND REINFORCEMENT AND REPRODUCTION ENGINEERING

NEW YORK

37 W. 65 St., 23

SAN FRANCISCO

1050 Howard St., 3

LOS ANGELES

1000 N. Seward St., 38





SYLVANIA RADIO TUBE "FIRSTS"



# WINNING THE BATTLE OF STANDARDIZATION

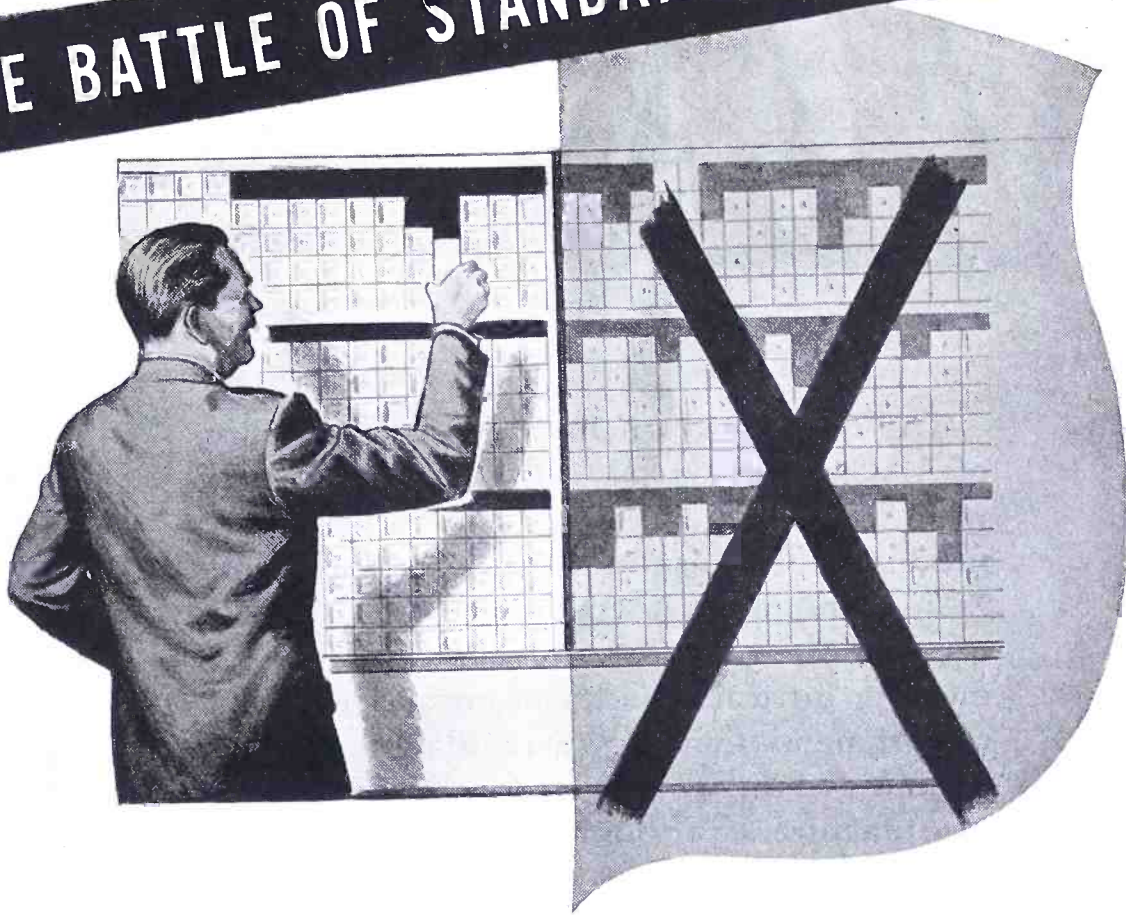
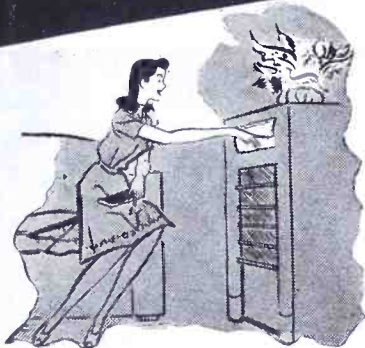

SYLVANIA was first to introduce a line of 6.3-volt radio tubes and to propose their universal use in not only automobile but home receivers.

That was back in the early 1930's. Prior to the introduction of these tubes, there was no agreement as to what types of radio tubes should be used for automobile service. Existing 2.5- or 5-volt types were either wasteful of battery current or did not have the efficiency needed. Standardization on 6.3-volt tubes of high efficiency would make it possible to effect manufacturing economies, to avoid complicated filament wiring arrangements, to save automobile battery drain, and to improve operating efficiency.

Sylvania's proposal met with opposition, but its common sense won the day. More and more radio-set manufacturers

specified 6.3-volt tubes in all types of new equipment. And, in time, 2.5-volt tubes became practically extinct except for replacements.

Winning this battle of radio tube standardization, furthermore, proved to be a boon to radio broadcast listeners. Elimination of the transformer in AC-DC sets reduced both the size and the cost of radio receivers. Millions who otherwise would not have been able to afford sets were able to take full advantage of broadcast information and entertainment.

You will always find Sylvania, exemplar of radio tube quality, on the side of standardization for the mass market.

That is why it pays to sell Sylvania.

*Quality that Serves the War Shall Serve the Peace*

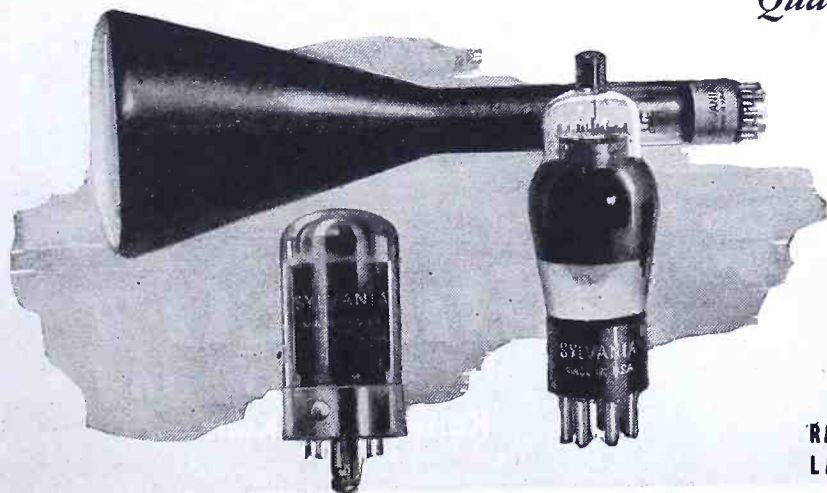

RADIO DIVISION



EMPORIUM, PENNSYLVANIA

# SYLVANIA

## ELECTRIC PRODUCTS INC.

RADIO TUBES, CATHODE RAY TUBES, ELECTRONIC DEVICES, FLUORESCENT LAMPS, FIXTURES AND ACCESSORIES, INCANDESCENT LAMPS

COMMUNICATIONS FOR NOVEMBER 1944 • 3

# AAC CRYSTALS

The recognized quality and dependability of AAC quartz crystals is the result of AAC's wide experience as one of America's largest producers of transmitters and other precision radio equipment. AAC quartz crystals and crystal units have proved so outstanding in meeting intricate specifications and exacting requirements that they are today demanded by many of the world's greatest airlines, radio manufacturers, various branches of the armed services and other government agencies.

This practical achievement background—plus AAC's staff of skilled engineers and modern-to-the-minute manufacturing facilities is ready to meet your crystal needs advantageously. Rapid delivery of standard types—also special types, ground and mounted to your specifications.

**ELECTRONICS DIVISION**  
Kansas City, Kansas



WRITE now for your free copy of the new AAC crystal catalog giving detailed facts about AAC quartz crystals and crystal units.

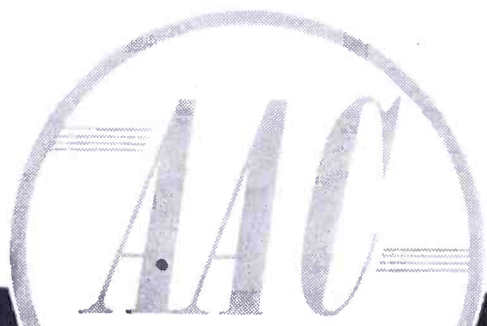
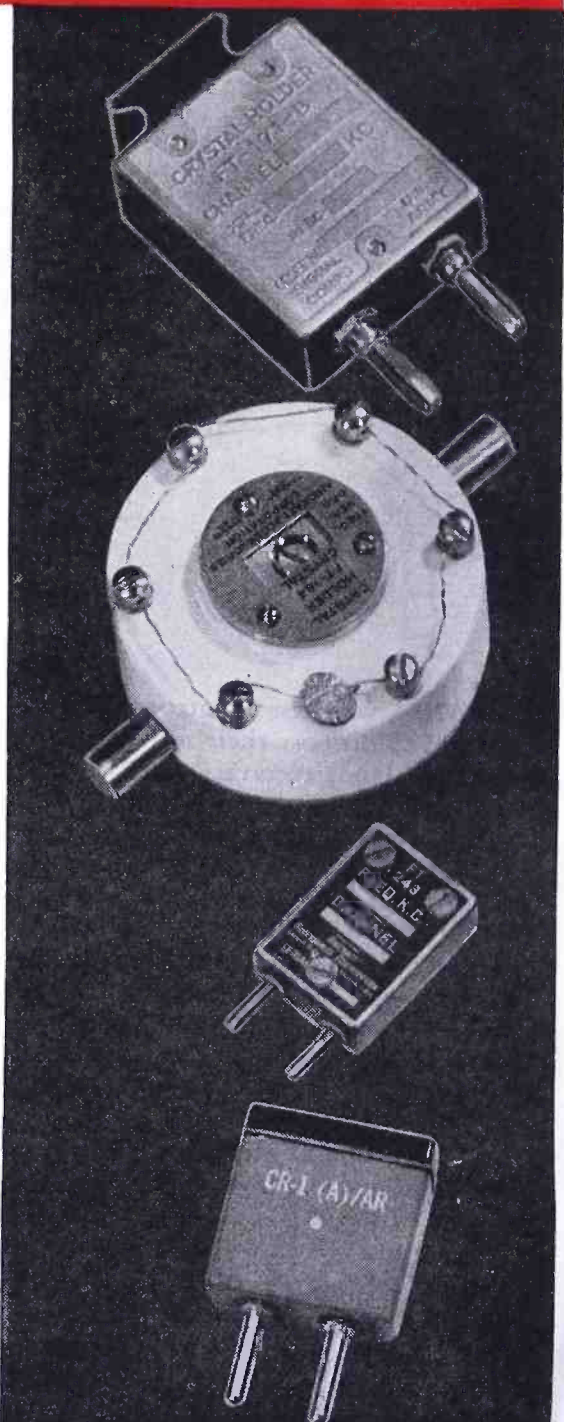

*Products*



**AIRCRAFT**  
RADIO and  
Kansas City, Kans.



# PRECISION MADE FOR PRECISE PERFORMANCE

*and*

## PROVED IN USE!

There is no question about AAC crystals meeting the most exacting requirements under severe operating conditions. Their reliability has been tested and proved a thousand times over . . . in battlefront service to the armed forces . . . in helping to keep the communication systems of many leading airlines working efficiently . . . in meeting the quality demands of radio manufacturers. The list of users of AAC crystals shown below is a tribute to the engineering skill and fine manufacturing facilities behind AAC crystals.



Braniff Airways, Inc.  
Chicago & Southern Air Lines, Inc.  
National Airlines, Inc.  
Northwest Airlines, Inc.  
Pan American Airways System  
Pan American-Grace Airways, Inc.  
Pennsylvania-Central Airlines Corp.  
Transcontinental & Western Air, Inc.

Colonial Radio Corp.  
Columbia Broadcasting System, Inc.  
Stewart-Warner Corporation  
Western Electric Company, Inc.  
Zenith Radio Corporation

Remember, crystal production is only one of AAC's services to the aviation and electronics industries. The production of airborne and ground radio equipment at the rate of more than 30 million dollars yearly for U. S. government and leading airlines demonstrates the wide scope and high rating of AAC manufacturing ability.

E-134

# ACCESSORIES CORPORATION

ELECTRONICS

New York, N. Y.

• ENGINEERED POWER CONTROLS

Burbank, Calif.

Cable Address: AACPRO

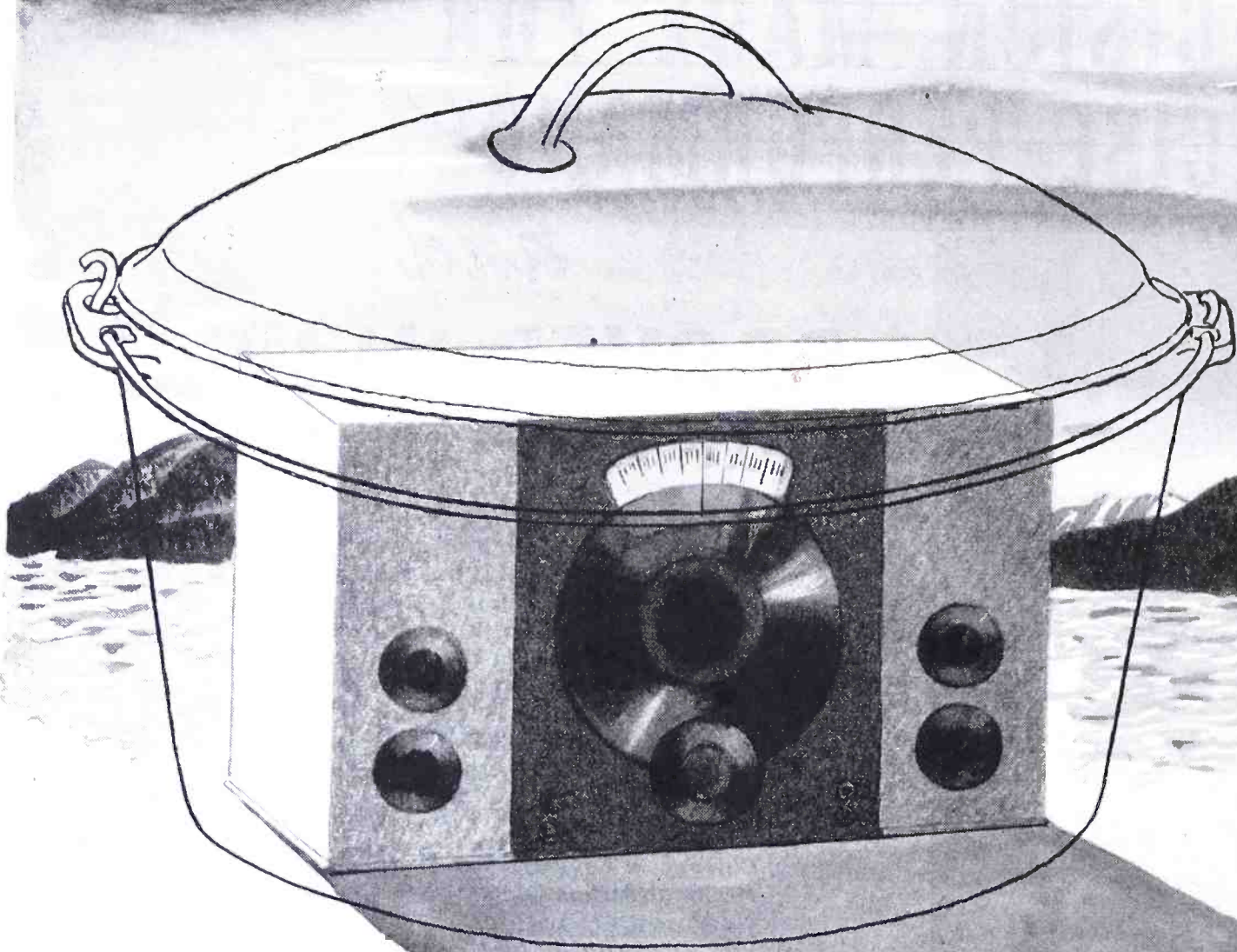

## the lid is still down

Only the most hazy hints may be given as to what you can expect in the way of more accurate, highly specialized electronic instruments when military secrecy is removed.

Into the past two years, a normal ten years of technological progress has been crammed. Out of it will come electronic instruments of amazing accuracy and of such rugged construction as to defy mechanical error. *-hp-* engineering has contributed much to these advancements. Some of the new *-hp-* instruments which are today doing combat service will set new standards in your laboratory and plant tomorrow.

If you are interested in radio broadcasting, television or frequency modulation . . . carrier current work, industrial heat-

ing or electronic controls, *-hp-* has an important date on your calendar of plans . . . a real stake in your future. Even though vital technical data cannot be released publicly today it is a practical idea for you to make known your requirements now so that much time may be saved in ultimately obtaining the solution to your problem. Among new instruments already perfected you may find just what is required. *-hp-* engineers are at your service without cost or obligation.

Direct Canadian inquiries to Atlas Radio Corp., 560 King St. West, Toronto 2, Canada.

**HEWLETT-PACKARD COMPANY**

Box 929 E

Station A

Palo Alto, California





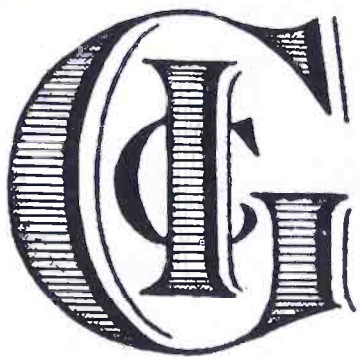

# radio components exclusively

As before, our total facilities will be devoted exclusively to the production of variable air condensers, push-button tuning devices, record changers and other radio components.

We will continue our established policy of producing a full line of types, sizes and specifications *plus exclusive special designs.*

## GENERAL INSTRUMENT CORP.

829 NEWARK AVENUE, ELIZABETH 3, N. J.



variable air condensers

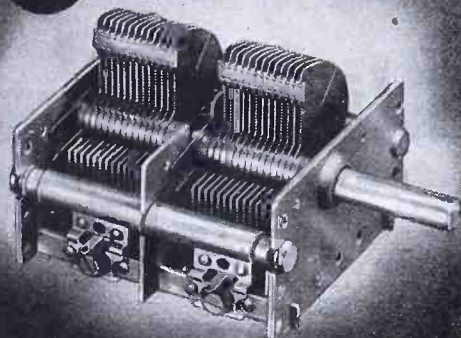

and push button tuning devices

record changers . . .



A line of new volume production models — simple — reliable — appealing.

NEW components? . . .



We're working on 'em now. Tell you later.

# AGAIN!

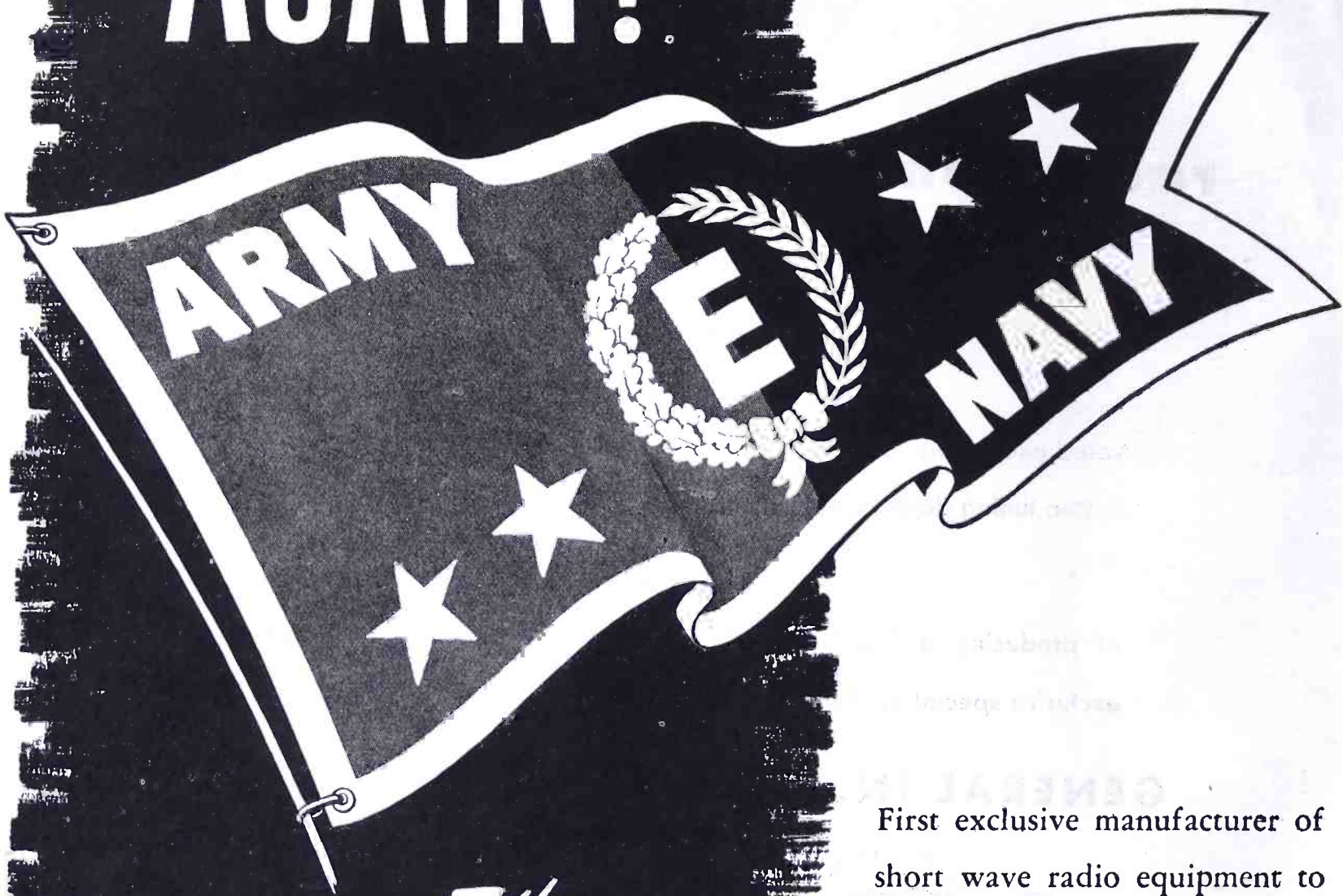

*For the 5<sup>th</sup> time*  
**hallicrafters**  
*employees win*  
*Army-Navy*  
*"E" Award!*

First exclusive manufacturer of short wave radio equipment to receive the coveted Army-Navy "E" Award for the fifth time . . . the result of the continued and untiring devotion to duty of the company's 1,500 employees.

## hallicrafters

THE HALLICRAFTERS COMPANY • MANUFACTURERS OF RADIO AND ELECTRONIC EQUIPMENT • CHICAGO 16, U. S. A.



Builders of the famous SCR-299

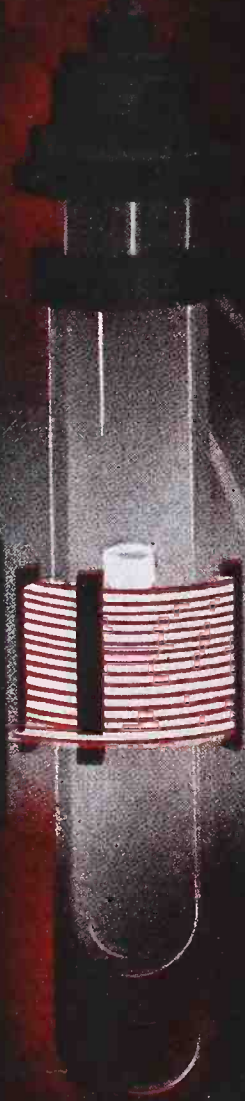

# Casting in a vacuum— Electronically

ANOTHER  
**MACHLETT**  
TECHNIQUE

One of the many vital processes that give Machlett vacuum tubes their remarkable quality is a novel method of casting electrodes in a vacuum. Complex parts of high-frequency oscillators, as well as X-ray tube anodes, are made by this unusual technique. Purified copper rod is placed over a mould in a graphite crucible, and the whole enclosed within a double-walled water-cooled quartz-silicon tube, which is encircled by a high-frequency coil. A vacuum of about  $10^{-5}$  mm. of mercury is maintained.

When the current is turned on, the metal melts and flows into the mould. Cooling is precisely controlled by adjusting the position of the heating coil, so that crystals form longitudinally, for

maximum heat transfer under operating conditions.

This method accomplishes a number of things, quickly and simply. No gases can be occluded in the metal to shorten tube life by reducing the vacuum. Oxides cannot form. There are no "pipes" in a casting thus poured. Dimensions can be held to about  $1/10,000$ th of an inch—and accurate dimensions are as important as metal purity in protecting transmitting tube performance, both assuring the maximum designed performance and long life. Techniques such as this make possible the production of the tube shown above . . . Machlett Laboratories, Inc., Springdale, Connecticut.

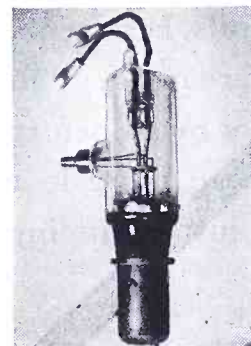

ML-846—An U. H. F. transmitting tube for television and F. M. and short wave broadcasting.

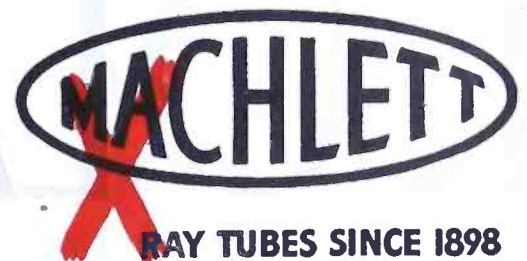

**RAY TUBES SINCE 1898**

TODAY THEIR LARGEST MAKER  
COMMUNICATIONS FOR NOVEMBER 1944 • 9



# GI Phone Booth .. Model 44

**T**HERE are few comforts for the man out in the forward observation post, but of one thing he can be sure—he has the best Communications Equipment in the world. For the Electronic Industry has gone all out to provide our G.I.'s with the finest . . . the best performing and the most dependable . . . Communications Systems that scientific discovery and manufacturing genius can produce.

The oldest and most respected names in audio communications are to be found on the components that make up these Systems and so it is that many of the Transformers, Coils, Headsets and other electronic parts are marked "Rola". It's a mark that meant much before the war . . . that will mean more in the Electronic Age now just beginning.

# ROLA

THE ROLA COMPANY, INC.

2530 SUPERIOR AVENUE • CLEVELAND 14, OHIO

Let's do more



in forty-four!

MAKERS OF THE FINEST IN SOUND REPRODUCING AND ELECTRONIC EQUIPMENT

# Bendix Radio Presents

## A NOTABLE IMPROVEMENT IN AIRLINE GROUND STATION EQUIPMENT

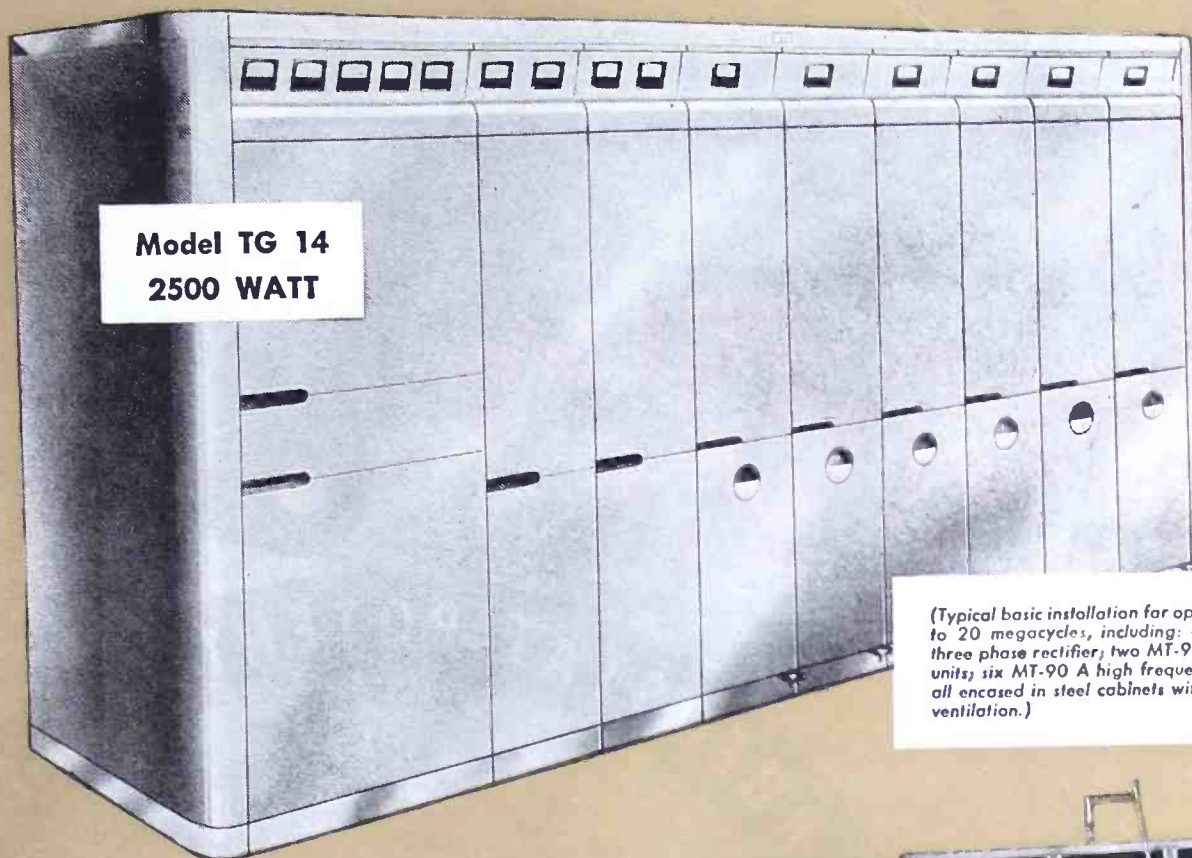

Model TG 14  
2500 WATT

(Typical basic installation for operation on 2.5 to 20 megacycles, including: one MP-36 A three phase rectifier; two MT-92 A modulator units; six MT-90 A high frequency RF units—all encased in steel cabinets with forced draft ventilation.)

### Great Flexibility . . . Exceptional Sturdiness . . . Complete Tropicalization

Bendix Radio\*—center of radio research and production for the aviation industry—has now turned its broad experience and extensive facilities to the production of the finest of ground station equipment—and here is one result: a new, unit-type installation providing an unlimited number of operating channels in the frequency range of 200-425 kc. and 2.5 to 20 mc. . . . with sufficient power supply capacity to permit simultaneous operation of 2 radio telephone, 1 radio telephone and 2 telegraph, or 3 telegraph channels . . . and designed to allow quick installation of additional RF channels as traffic loads increase.

Constructed to the quality requirements which have made the products of Bendix Radio the Standard of the Aviation Industry, this equipment has hermetically sealed transformers for tropical use, and is studded throughout with other features to assure peak performance under all conditions. As a further guarantee of reliability, *special attention has been given to adequate overload protection, and improved electrical design assures the effective reduction of Harmonic Radiation to a minimum.*

Information as to dimensions, weight, construction, electrical characteristics and easy-service features will be sent promptly on request.



The MS-77 Remote Control Unit, built to individual requirements, provides a method of installing control equipment in a manner which will place all the equipment in locations readily accessible to the operator. The compact low structure of this unit permits it to be installed in such a way that the operator may have a full unobstructed view in all directions.

\*TRADE-MARK OF BENDIX AVIATION CORPORATION

# Bendix RADIO DIVISION

BENDIX AVIATION CORPORATION BALTIMORE 4, MARYLAND

STANDARD FOR THE AVIATION INDUSTRY

COMMUNICATIONS FOR NOVEMBER 1944 • 11

# For special requirements

## DeJUR ELECTRICAL INSTRUMENTS

**1 1/2 INCH METER • SQUARE TYPE • MODEL 112**  
 This miniature instrument may be successfully used in a variety of applications, and it is particularly useful where space is an important factor. The DeJur 112 measures only 1 3/4" square and 25/32" deep, and uses basically the same carefully designed components as our larger instruments. In order to conserve space, soldering lugs are used for the terminal connections instead of the conventional studs. Available in standard ranges.

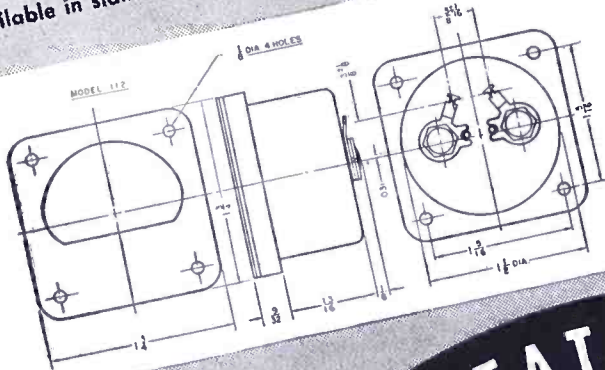
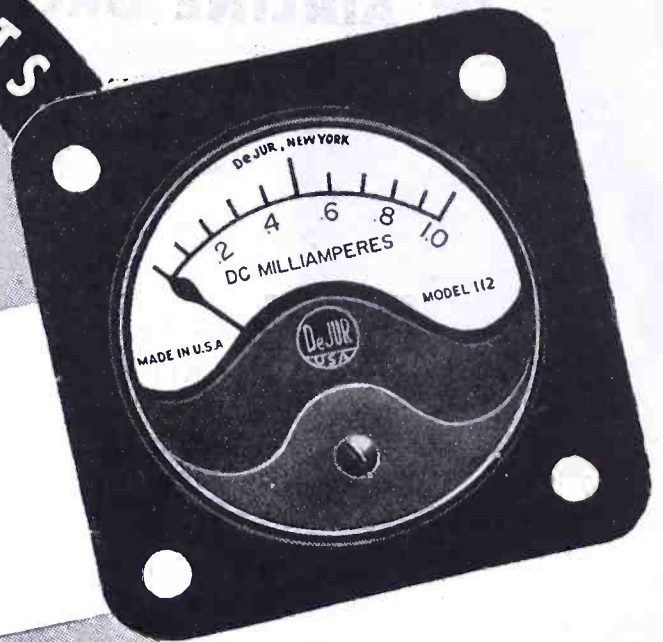

## DeJUR RHEOSTAT-POTENTIOMETERS

**MODEL 241 D**  
 A dual unit model, with both units mounted together. The Model 241 D is typical of the many types developed by DeJur engineers for special requirements. We are equipped to serve your needs, too.

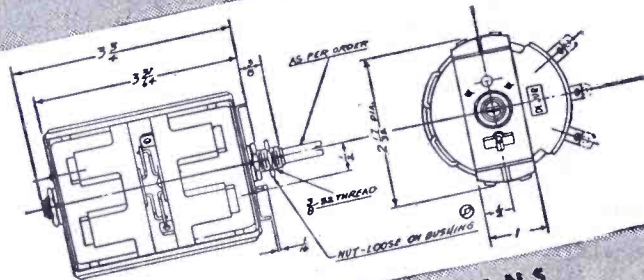

SPECIFICATIONS		MODEL NO.
50 WATTS	RANGE IN OHMS	241 D
RANGES—10 to 10,000 Ohms	0. 10	241 D
MECH. ROTATION—300°	0. 50	241 D
ELEC. ROTATION—270°	0. 100	241 D
WEIGHT—7 Oz.	0. 500	241 D
	0. 1,000	241 D
	0. 5,000	241 D
	0. 10,000	241 D



Write for the NEW DeJur Catalog

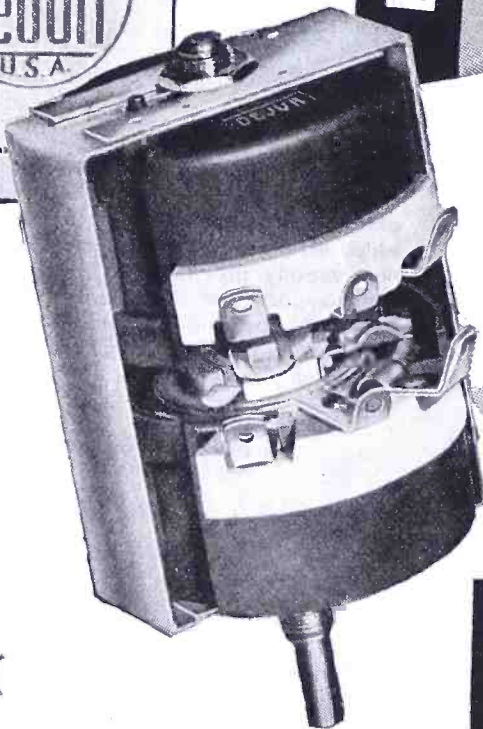

# DeJur-Amsco Corporation

GENERAL OFFICE: NORTHERN BLVD. AT 45th ST., LONG ISLAND CITY 1, N. Y.

Buy and Hold More WAR BONDS

12 • COMMUNICATIONS FOR NOVEMBER 1944

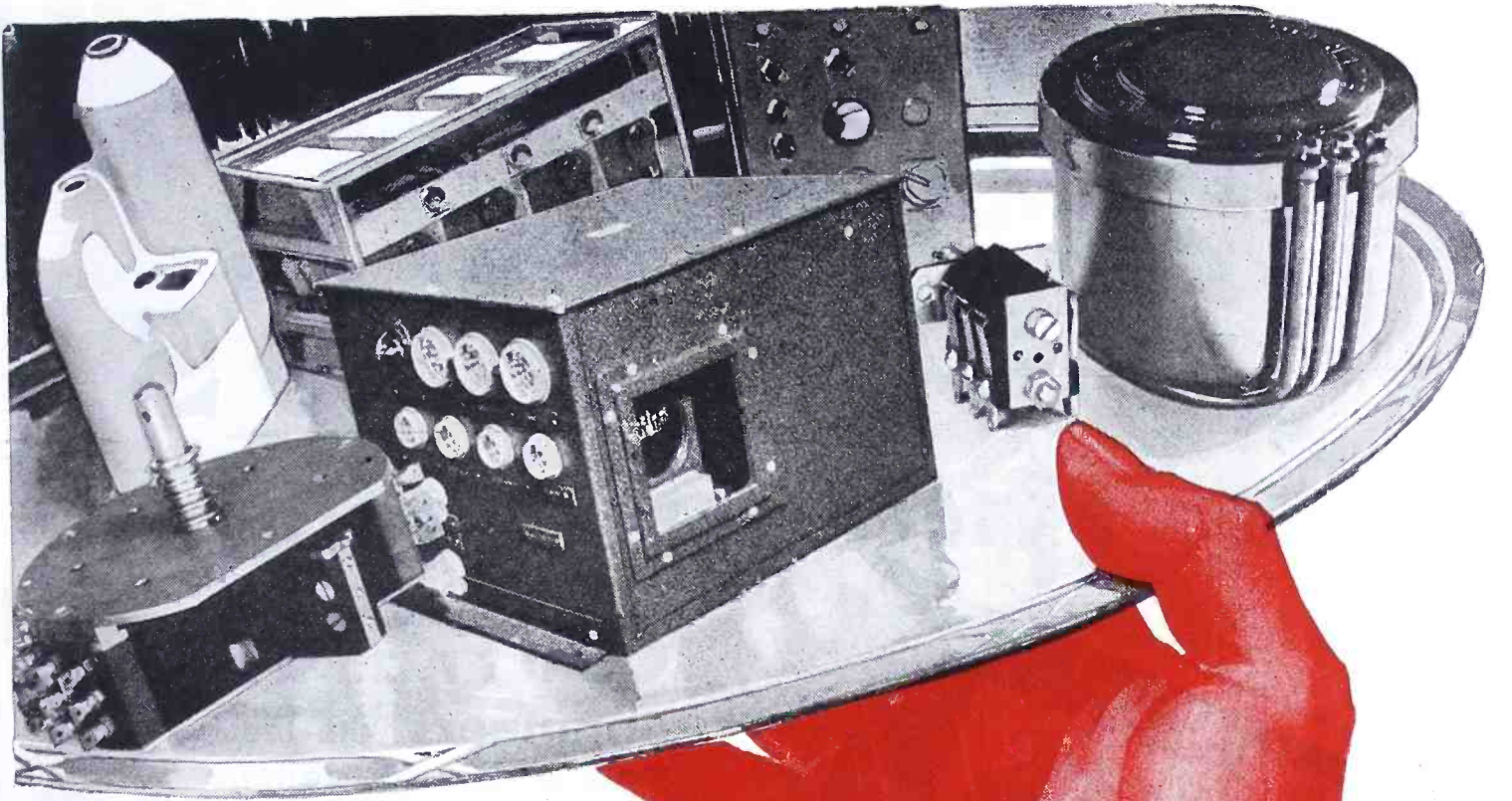

## SPECIALIZED SKILLS A DIME A DOZEN

**B**UT what makes Lewyt "different" is the ability with which we use our specialized skills for *your* benefit... especially when you've got your eye on post-war cost-conscious buyers.

Will there be many sub-contractors in wartime products bidding for your work? Be cautious, then, with those of only war-born experience... whose production education is largely limited to the lush years of "Cost-Plus" operations.

But in the period of re-conversion to a civilian economy, cost-sensitive production will be an imperative *must*. There will be no place or time for carelessness, or laxity, or indifference to costs.

Lewyt is *not* a war baby. Lewyt is a "Manufacturer's Manufacturer" with 56 years of widely diversified production experience... with highly developed skills for making things better at less cost. We are doing it for many of the greatest names in American Industry. Perhaps we can "whet your appetite" for some of these skills, too.

It costs nothing to consult us. Even if present conditions preclude figuring on the job *now*, we can quote on WAR BONDS. They start at \$18.75.

### CHECK THESE OPERATIONS FOR IMPORTANT SAVINGS

We specialize in electric and electronic instruments, chassis and housings; mechanical and electrical assemblies; highest precision machine work; sheet metal fabrications; all types of welding, product finishing, etc. Write on your business stationery for illustrated 48-page book, "Let Lewyt Do It" ... postage paid, no charge, no obligation. See Lewyt listings in Thomas' Register. LEWYT CORPORATION, 76 BROADWAY, BROOKLYN 11, N. Y.

# Lewyt

LET LEWYT DO IT



# Take advantage of Centralab's experience in ceramics

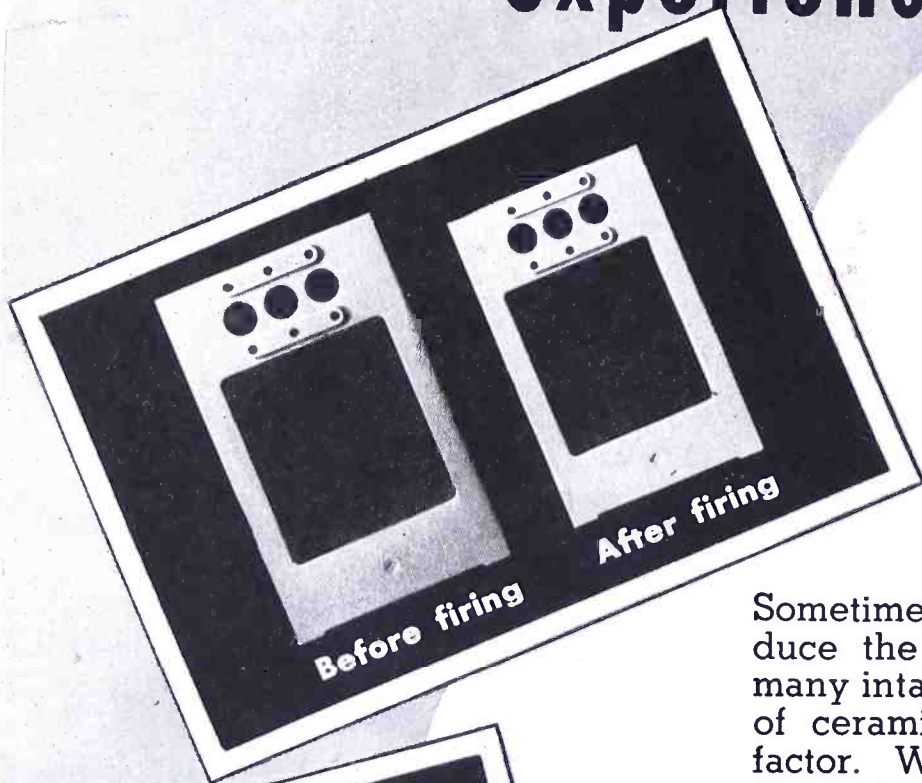

**Centralab engineers** with their wealth of experience, through which millions of Ceramic parts have been produced, have learned the HOW and WHY

Each shape and form has its own peculiarities. The slide rule and the logarithmic scale do not always apply.

Sometimes TRIAL and ERROR produce the final result. One of the many intangibles in the manufacture of ceramics is the sizeable shrink factor. Witness these unretouched illustrations.

Some things can and some things CANNOT be done. So before you make a complete design in which ceramics are a vital part, we welcome your consultation with our engineers.



# Centralab

Division of GLOBE-UNION INC., Milwaukee

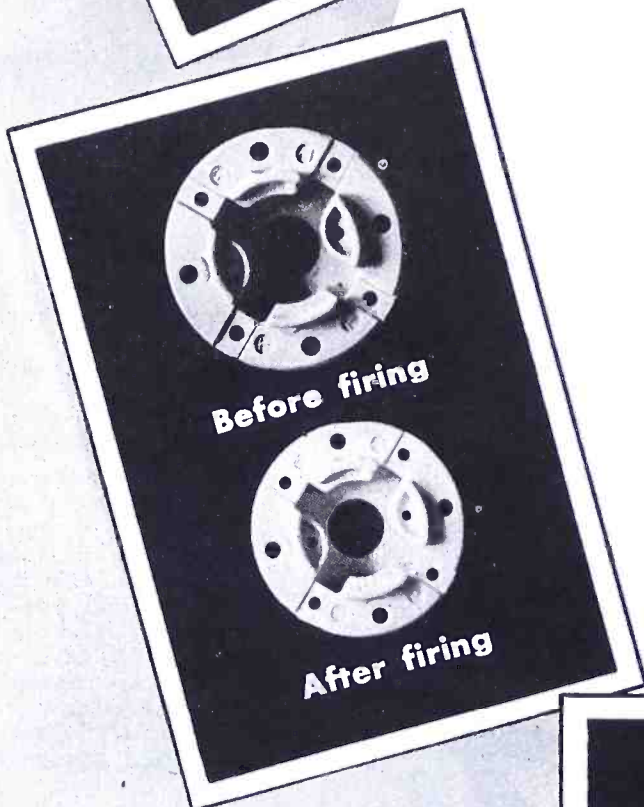

Producers of Variable Resistors • Selector Switches • Ceramic Capacitors, Fixed and Variable • Steatite Insulators.

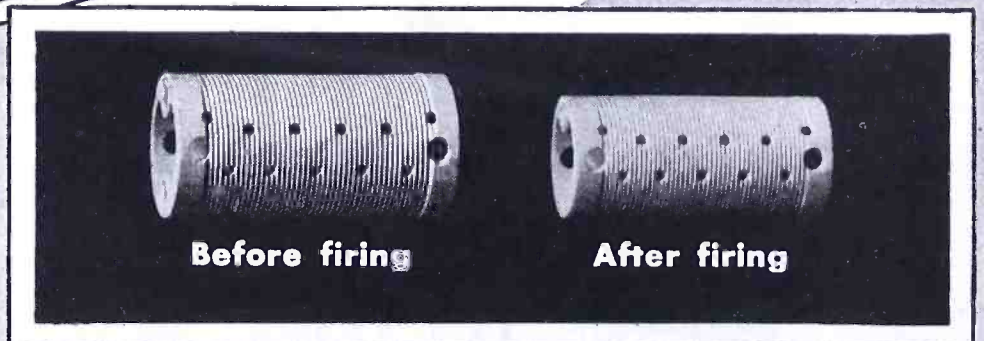



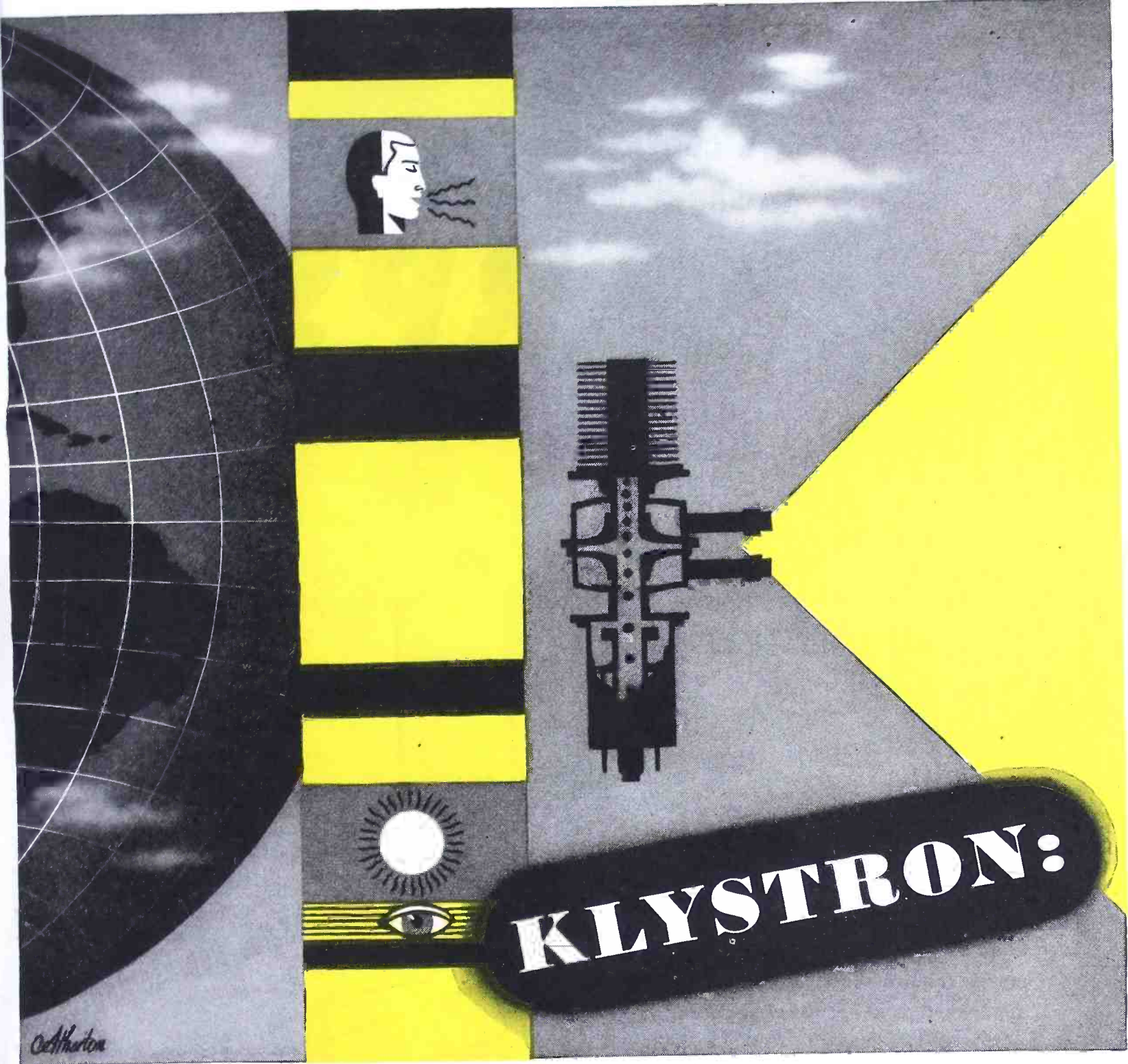

## Makes *vhf* waves behave

**T**HE KLYSTRON converts DC energy into radio frequency energy by modulating the velocity of an electron beam between spaced grids.

The ultra-high-frequency waves thus generated are so short that they approach heat and light waves in the electro-magnetic spectrum.

This makes it possible to project, by reflection, a shaped beam of *vhf* waves. Sperry engineers have put this principle to work in important wartime devices for our Armed Forces.

▶ **Klystrons are now in quantity production, and certain types are available. Write for information.**

The name "KLYSTRON" is a registered trade-mark of the Sperry Gyroscope Company, Inc.

• • •

Like other Sperry devices, Klystrons are also being made during the emergency by other companies.

**Sperry Gyroscope Company**  
INC.  
GREAT NECK, N. Y. • DIVISION OF THE SPERRY CORPORATION

GYROSCOPICS • ELECTRONICS • AUTOMATIC COMPUTATION • SERVO-MECHANISMS

COMMUNICATIONS FOR NOVEMBER 1944 • 15

So convert paper plans  
to sheet metal products is

# KARP'S JOB

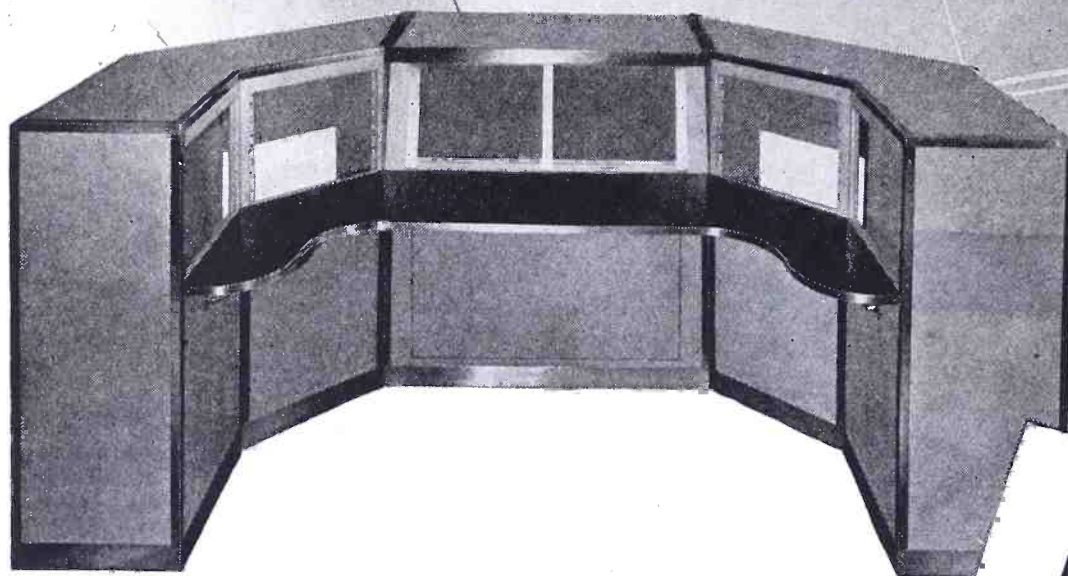

Give us the specifications or plans for your sheet metal requirements, and KARP will produce a superior finished product because . . .

- ★ We have engineers and craftsmen with a "golden touch" to create anything in sheet metal.
- ★ We have complete metal working facilities, including hundreds of stock dies to lower or eliminate die costs.
- ★ All orders are custom built with typical KARP ingenuity.
- ★ Competitive prices! Prompt deliveries!

SUPPORT THE SIXTH WAR LOAN DRIVE

**KARP METAL PRODUCTS CO., INC.**

30th STREET • BROOKLYN 32, N. Y.

## KARP Sales Representatives

*are strategically located all over the country. A card to this office will bring our representative in your district to consult with you.*

# Proving ground for Norelco Cathode Ray Tubes

**T**HE uniform characteristics, long life and outstanding performance of NORELCO Cathode Ray Tubes are the result of exceptional manufacturing skill supplemented by rigid tests applied to each tube as it comes off the production line.

As an example of the care exercised, the electronic test set, shown here, subjects every cathode ray tube to 30 different checks, such as line width, light output, plate alignment, base-to-shell alignment, uniformity of cathode surface, astigmatism, presence of gas, and screen condition. A total of 90 exacting tests of raw materials, parts, sub-assemblies, assemblies and performance guard cathode ray tube quality.

This is typical of the great lengths to which North American Philips goes in producing high performance NORELCO electronic tubes. Behind this company is an organization with world-wide experience resulting from over fifty years of electrical research and development.

Although all the tubes we produce now go to the armed forces, we invite inquiries from prospective users. A list of tube types we are especially equipped to produce will be sent on request.

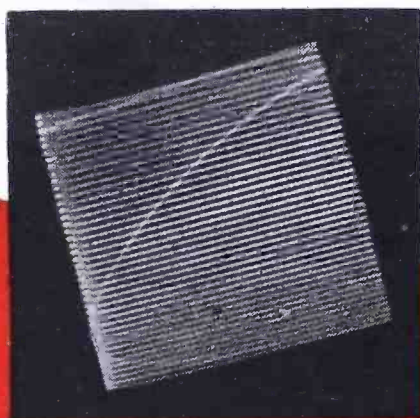

Pattern used for measuring light output by means of photoelectric cell. Frequency— $60 \times 2940$  cycles.

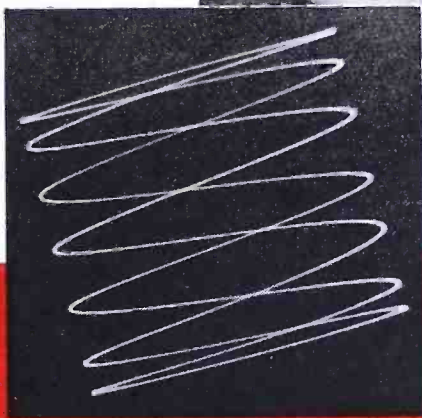

Trace showing absence of astigmatism. Frequency— $60 \times 420$  cycles.

Uniformly bright spot on screen of 5 CPI cathode ray tube in test set indicates perfectly formed cathode.

Write today for interesting booklet, describing the background of North American Philips in the science of electronics.

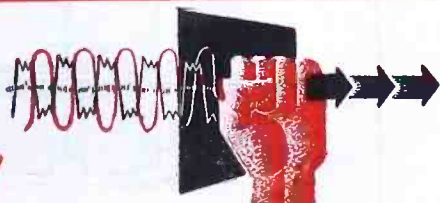

**Norelco** Electronic Products by  
Reg. U. S. Pat. Off.

**NORELCO PRODUCTS:** Quartz Oscillator Plates; Amplifier, Transmitting, Rectifier and Cathode Ray Tubes; Searchray (X-ray) Apparatus; X-ray Diffraction Apparatus; Medical X-ray Equipment, Tubes and Accessories; Electronic Measuring Instruments; High Frequency Heating Equipment; Communications Equipment; Tungsten and Molybdenum products; Fine Wire; Diamond Dies. When in New York, be sure to visit our Industrial Electronics Showroom.

**NORTH AMERICAN PHILIPS COMPANY, INC.**

Dept. E-11, 100 East 42nd Street, New York 17, N. Y.  
Factories in Dobbs Ferry, N. Y.; Mount Vernon, N. Y. (Metalix Div.); Lowell, Me. (Elmet Div.)

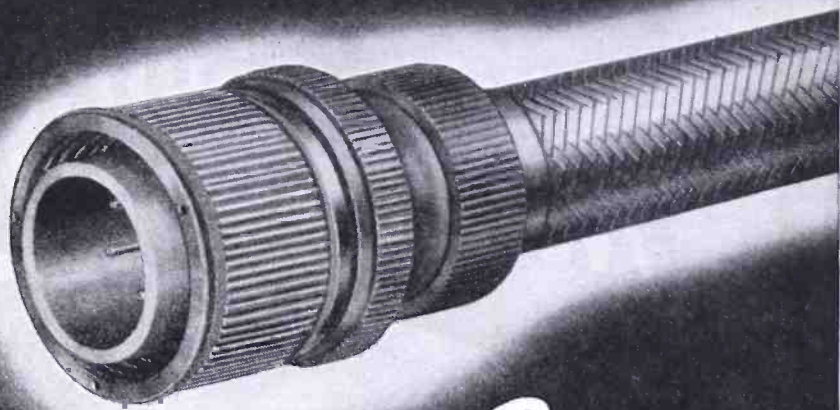
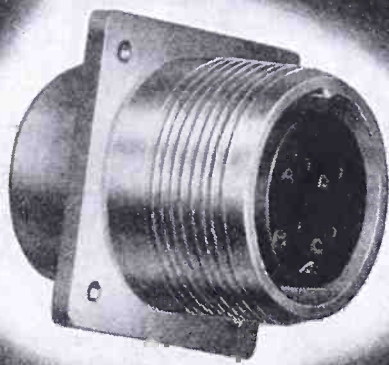

*Looks Simple?*



—here's what it takes to make a good **DISCONNECT PLUG**

● There are more than 25 precision-made parts in the average Multiple Circuit Electrical Connector. When assembled, they perform their function—that of making or breaking many electrical circuits simultaneously—with the utmost simplicity and efficiency. Such simplicity in operation is the end result of years of research, many refinements and great skill in manufacture. The Breeze Multiple Circuit Electrical Connector reflects in the efficiency with which it does its job, the experience which went into its production—the background which has made Breeze a leading producer of many different types of aircraft and electrical accessories.

*Breeze*



**CORPORATIONS, INC.**

NEWARK, N. J.

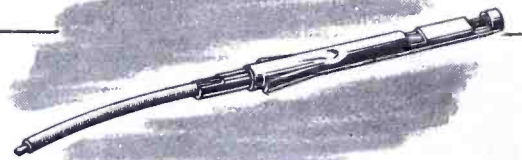

Socket construction features spring-loaded contact for positive electrical connection with pin.



Both pin and socket feature spring snap for ease of assembly in housing insulators after soldering

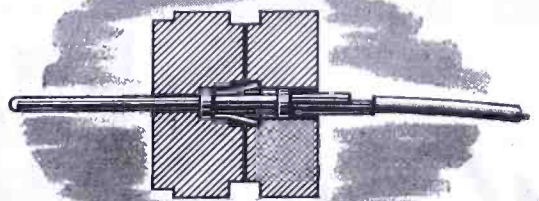

Cross-section illustrating how contact pin is snapped into place after soldering on lead wires.

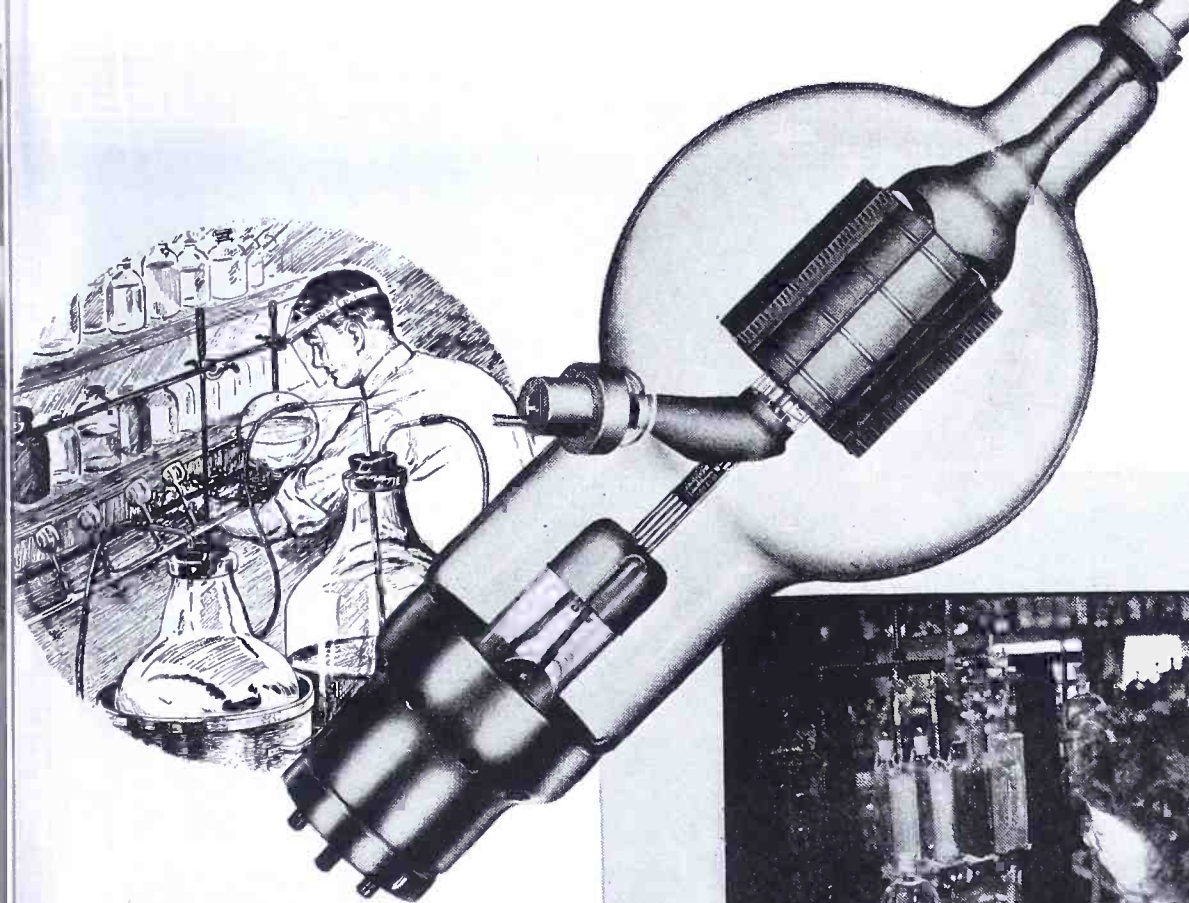

# the *Science* behind the science of electronics

The pattern of progress in the science of electronics is determined by the achievements in creating and developing new and more efficient electron vacuum tubes. Therefore, the whole complex task of vacuum tube development — involving the intelligent application of many sciences — comprises the real science behind the science of electronics.

To create and produce the modern vacuum tube requires experience and skill of the highest order in these many sciences in addition to complete facilities for their application. The list includes everything from chemistry and metallurgy — the technology of glass fabrication and vacuum pumping — to physics, optics, thermo-dynamics and most important of all — Electronics.

The resources and resourcefulness of Eimac laboratories have accounted for many outstanding contributions to the science of Electronics. A fact which is attested to by the leadership which Eimac tubes enjoy throughout the world. These comprehensive facilities are continuously being utilized to achieve better and better results for the users of Eimac tubes.

Eimac Engineering is devoted solely to the development and production of electron vacuum tubes. However, since the electron vacuum tube is the heart of all electronic devices it is advisable for users and prospective users of electronics to look first to the vacuum tubes required. A note outlining your problem will bring advice and assistance without cost or obligation.

Write for your copy of *Electronic Teles* — a 64 page booklet fully illustrated — covering fundamentals of Electronics and many of its important applications. Written in layman's language.



*A few of the branches of the Science  
behind the Science of Electronics*

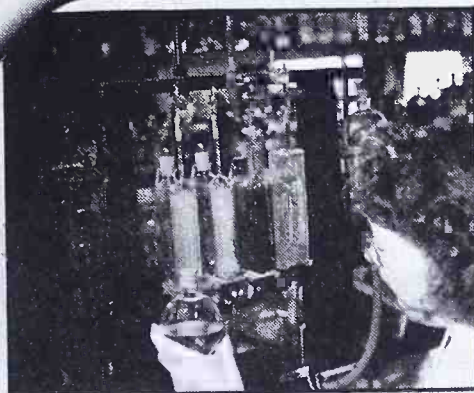

**CHEMISTRY**—Making Gas Analysis in the Eimac Laboratory

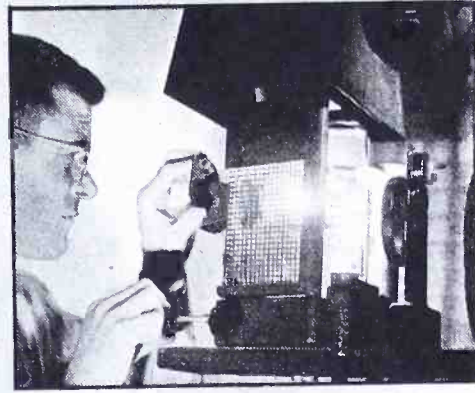

**METALLURGY**—Spectrographic Analysis of the Rare Metals Used in Vacuum Tubes

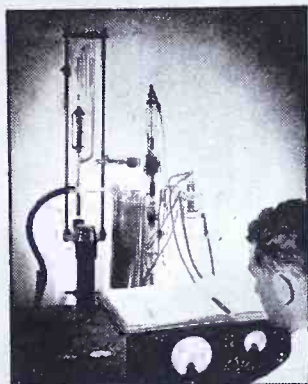

**VACUUM TECHNOLOGY**—Constant Research to Develop Better Vacuum Techniques



**PHYSICS**—Actually Viewing Emission of Electrons with Electron Microscope



**ELECTRONICS**—Determining Facts about and Recording Data on Vacuum Tube Capabilities



**OPTICS**—Studying the Effect Processing has on the Structure of Materials Through Photomicrography

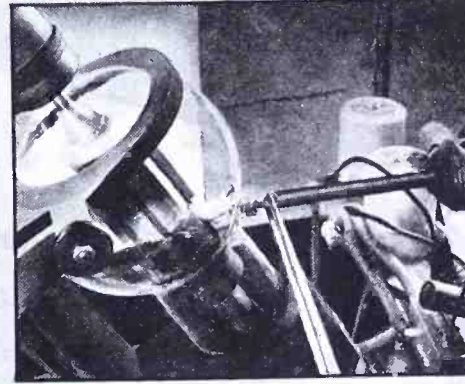

**GLASS TECHNOLOGY**—Special Equipment and Technique to Produce Complicated Glass Structures

Follow the leaders to

**Eimac**  
REG. U. S. PAT. OFF.  
**TUBES**

**EITEL-McCULLOUGH, INC., 869 San Mateo Ave., SAN BRUNO, CALIF.**

Plants located at: San Bruno, California and Salt Lake City, Utah

Export Agents: FRAZAR & HANSEN, 301 Clay Street, San Francisco, California, U. S. A.

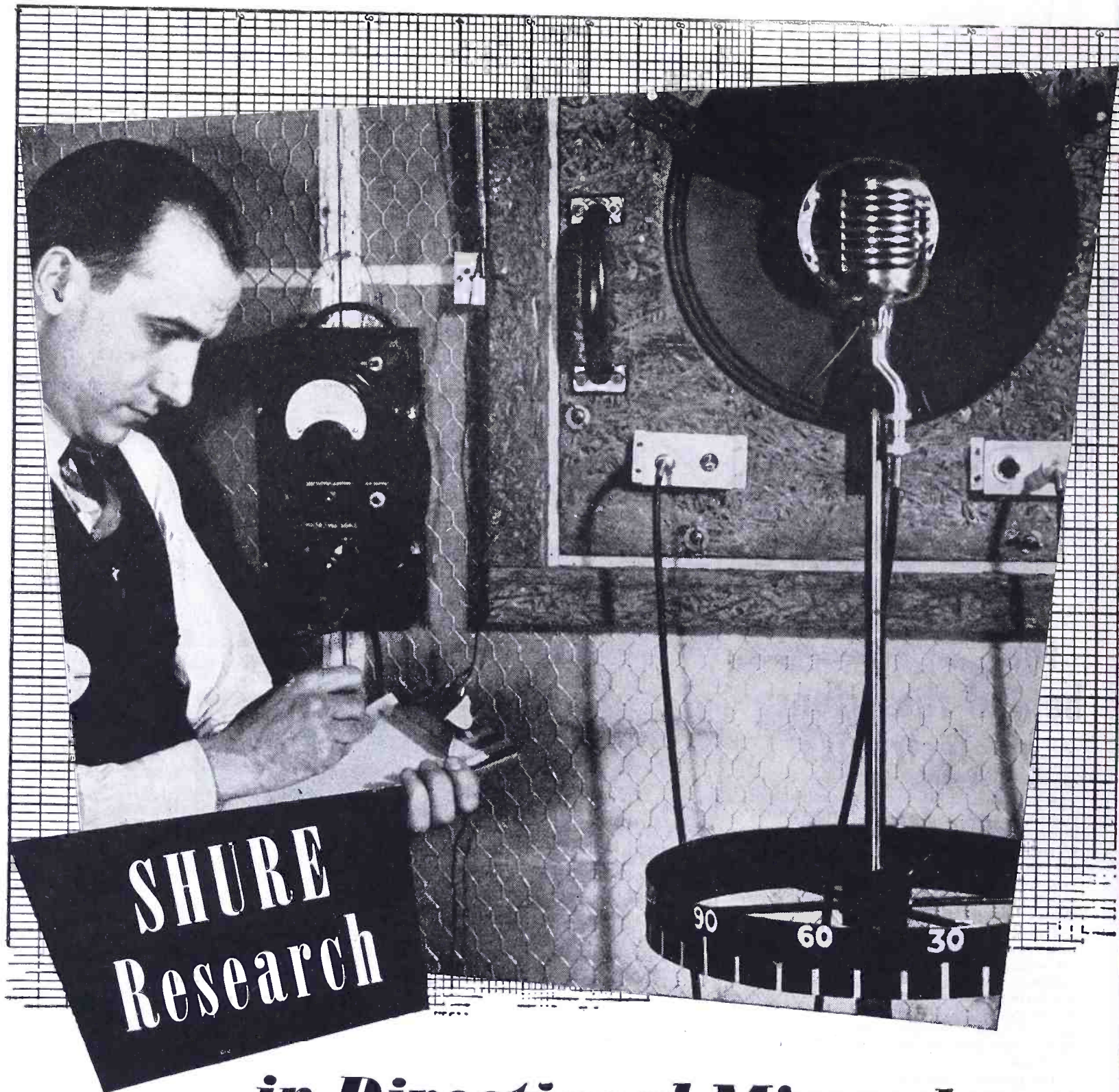

**SHURE  
Research**

## **... in Directional Microphones**

It is not enough to design a Microphone that merely converts sound waves into electrical impulses. A Microphone, to be truly useful in modern broadcasting, should be discriminating enough to accept wanted sounds — and reject unwanted sounds. Shure Research was the first to develop a single unit uni-directional Microphone, both crystal and dynamic.

Shure Research is the reason why practically every major broadcasting station uses the Shure 556 Unidyne. Shure Research is your assurance of postwar microphone superiority.

**SHURE BROTHERS, 225 West Huron Street, Chicago**  
*Designers and Manufacturers of Microphones and Acoustic Devices*



# FIRST OFFICIAL PICTURE

Of the New

**HARVEY REGULATED**

**POWER SUPPLY 206 PA**

**RANGE 500 to 1000 VOLTS**

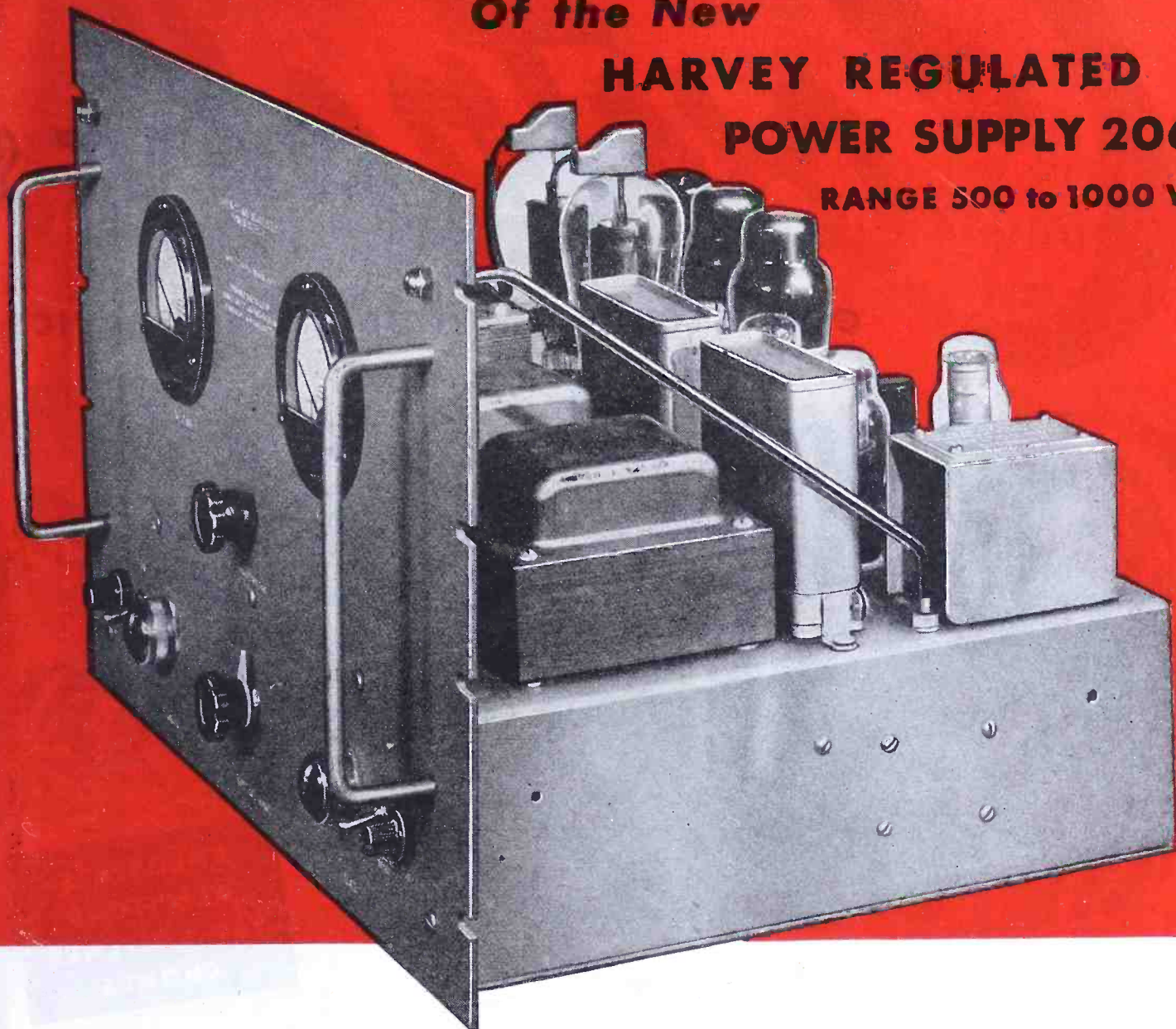

*Look It Over!* You'll see the quality craftsmanship and compact construction of this new HARVEY 206 PA—its sound design, precision assembly and easy accessibility. Notice the gray, crackle-finish panel and the copper plated chassis.

The new Harvey 206 PA is equipped with spare fuses, a generous 6 ft. heavy duty Typex cord, two interlocks for safety, overload and time delay relays—everything to make it a thoroughly dependable, easy-to-operate source of laboratory D. C. power.

Although the picture gives you an indication of why the HARVEY 206 PA operates smoothly and efficiently, it can't show you how this precision instrument operates in two ranges—500 to 700 volts at  $\frac{1}{4}$  of an ampere; 700 to 1000 volts at .2 of an ampere—with both ranges accurately regulated within one per cent. That's up to the instrument and us. We'd like nothing better than the chance to show you just what this important new development can do. Get in touch with

**HARVEY**

OF CAMBRIDGE

**HARVEY RADIO LABORATORIES, INC.**

442 CONCORD AVENUE • CAMBRIDGE 38, MASSACHUSETTS

# OHMITE

# Control UNITS

GIVE ACCURATE, TROUBLE-FREE SERVICE

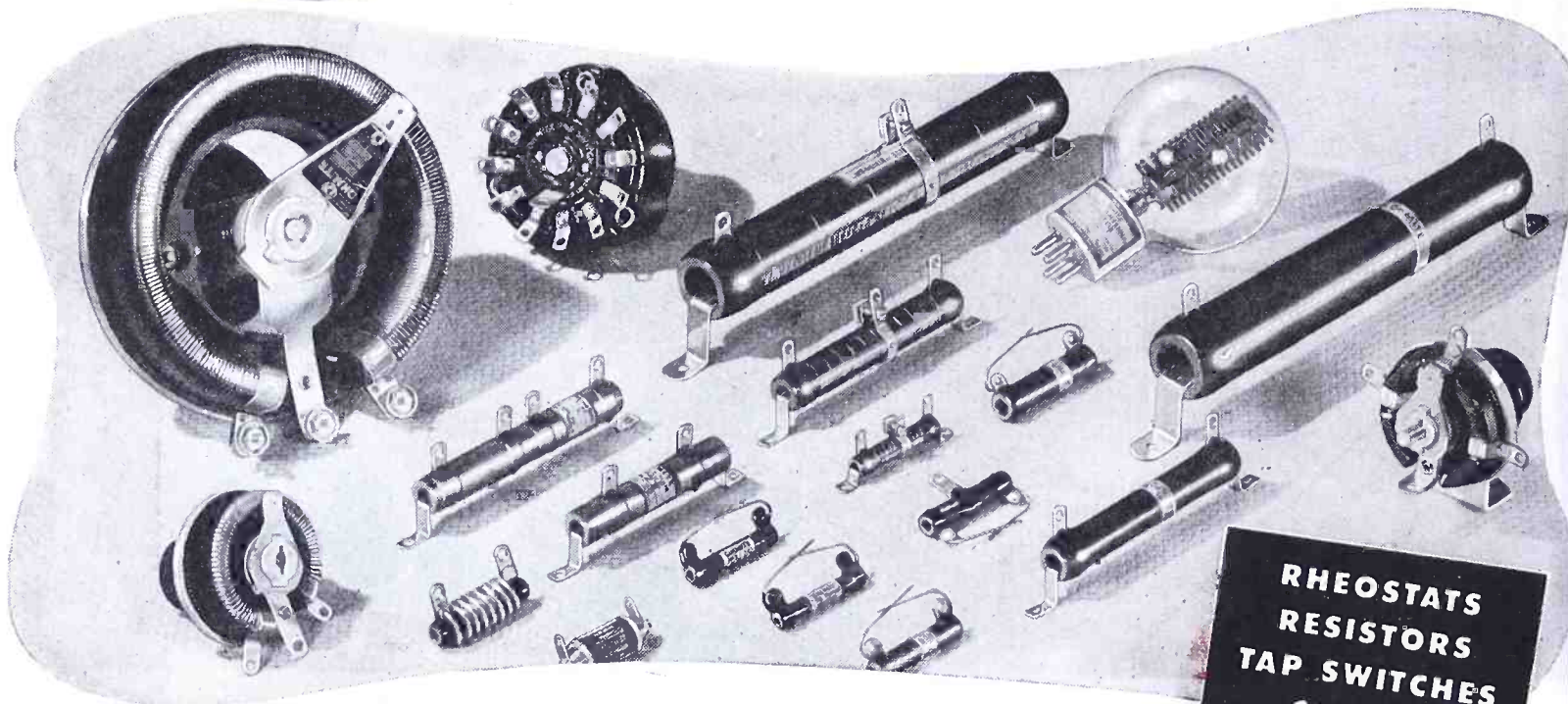

**RHEOSTATS  
RESISTORS  
TAP SWITCHES  
CHOKES**

Designed and Built  
to Withstand

**SHOCK**

**VIBRATION**

**TEMPERATURE EXTREMES**

**HUMIDITY**

**ALTITUDE**

● Because they are so consistently reliable in actual service . . . Ohmite Rheostats, Resistors, Chokes and Tap Switches have become "the control engineer's control units."

Shown here are a few of the many types extensively used in military and industrial equipment. The wide variety of types and sizes in stock or special units provides a ready and exact answer to most applications.

In designing for war or postwar, let Ohmite experience help you.

**OHMITE MANUFACTURING COMPANY**  
4869 Flourney Street Chicago 44, U.S.A.



For helpful data and information, write on company letterhead for Industrial Catalog and Engineering Manual No. 40. Address Ohmite Manufacturing Co., 4869 Flourney Street Chicago 44, Ill.

Be Right with **OHMITE**

RHEOSTATS • RESISTORS • TAP SWITCHES



# ELECTRONIC RESEARCH FOR INDUSTRY

The National Union Laboratories are now available to complete your established engineering facilities



There is no need to postpone your electronic research program, awaiting the day when competent engineers, costly equipment and scarce materials can be obtained. You can start right now and be far ahead by having National Union Laboratories take over this highly specialized part of your work, thus rounding out

the development activities of your existing engineering group.

Whether you are interested in a single project or a complete service—we invite you to investigate National Union Electronic Research. Let's talk it over. There is no obligation whatever. Please address inquiries to Department C.

**NATIONAL UNION RESEARCH LABORATORIES**  
National Union Radio Corporation Newark 2, New Jersey

# Another DuMONT Contribution...

## TYPE 247 CATHODE-RAY OSCILLOGRAPH

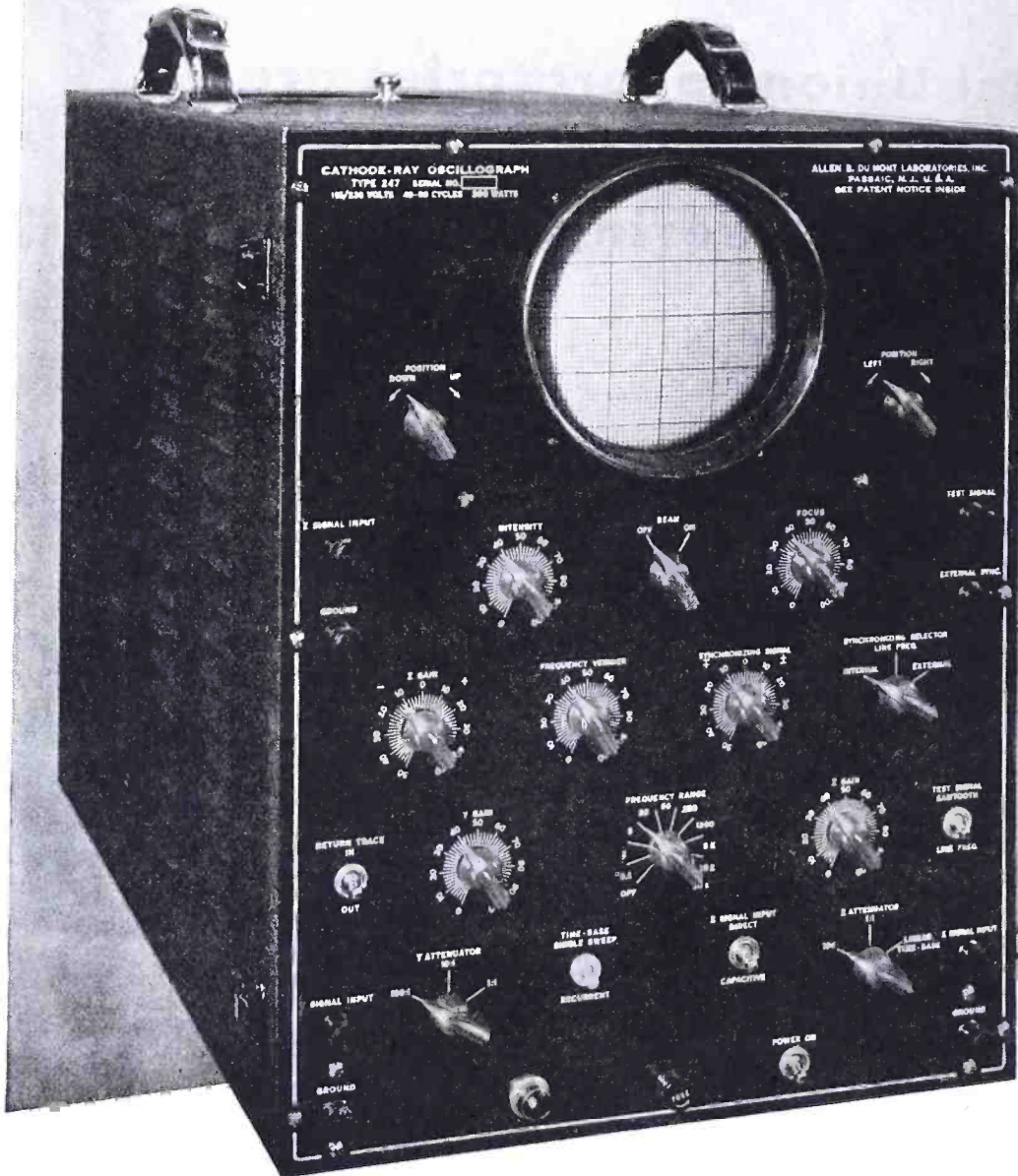

Uses new Army-Navy preferred Type 5CP1 cathode-ray tube with intensifier electrode operated at overall accelerating potential of 3000 v. High-intensity patterns. 5" dia. screen.

Medium-persistence green screen, standard. Also available with short-persistence blue screen Type 5CP5 tube for high-speed photographic recording. Or Type 5CP2 long-persistence green screen for visual observation of low-speed phenomena.

Vertical or Y-axis amplifier response does not fall more than 10% below the uniform value from 2 to 200,000 C.P.S. Sufficient gain for maximum deflection factor of 0.05 r.m.s. volt input signal for 1" deflection of beam.

Distortionless, continuously-variable low-impedance attenuator or gain control. Stepped attenuator with ratios of 1:1, 10:1 and 100:1.

X-axis or horizontal amplifier accommodates signal produced by linear time-base generator. Reasonably uniform response from d-c to 100,000 sinusoidal C.P.S. Signal amplitude of 0.5 v. r.m.s. sufficient for deflection of 1" through amplifier.

Recurrent, repetitive and single-sweep operation of linear time-base generator. Continuously variable from 0.5 to 50,000 sawtooth cycles per second. Single sweep of writing rates corresponding to 0.5 to 10,000 cycles per second.

Z amplifier channel for applying external signal to grid or modulating electrode of cathode-ray tube.

Steel case. Black wrinkled finish. Copper-finished steel chassis. Two carrying handles. 14" w.; 19" h.; 26" d. 130 lbs.

▶ This latest oscillograph facilitates the investigation of transient as well as recurrent phenomena over a wide frequency range. And since a permanent record of transient phenomena is usually desirable, this instrument provides for such photographic recording by applying comparatively high accelerating potentials to its cathode-ray tube. Furthermore, a new type of beam-control circuit is incorporated.

The sweep frequency range has been extended. The instrument may be used for observations on low-speed machinery and for other low-frequency signal functions—even down to  $\frac{1}{2}$  cycle per second. At the other extreme, the instrument handles radio-frequency signals as high as 500 kilocycles. The time-base has the necessary range to display such signals properly. Also, the vertical amplifier can satisfactorily accommodate them.

▶ Literature on request . . .

© ALLEN B. DUMONT LABORATORIES, INC.

# DUMONT

## Precision Electronics & Television

ALLEN B. DUMONT LABORATORIES, INC., PASSAIC, NEW JERSEY • CABLE ADDRESS: WESPEXLJN, NEW YORK

# An Important Statement

BY MYCALEX CORPORATION OF AMERICA

Issued in an Effort to Clear up and to  
Avoid Continued Confusion in the Trade.

It has come to our attention that in some quarters electronic engineers and purchasing executives are under the erroneous impression that the MYCALEX CORPORATION OF AMERICA is connected or affiliated with others manufacturing glass-bonded mica insulation, and that genuine "MYCALEX" and products bearing similar names are all "the same thing" . . . or "put out by the same people" . . . or "come from the same plant."

## These are the facts:

1. The MYCALEX CORPORATION OF AMERICA is not connected or affiliated with any other firm or corporation manufacturing glass-bonded mica insulating materials. It is 100% American in ownership and operation.
2. The word "MYCALEX" is a registered trade-mark owned by the MYCALEX CORPORATION OF AMERICA, and identifies glass-bonded mica insulating materials manufactured by MYCALEX CORPORATION OF AMERICA.
3. The General Electric Company, by virtue of a non-exclusive license it had under a MYCALEX patent through the MYCALEX (PARENT) COMPANY LTD., has been permitted use of the trade-mark "MYCALEX" on its glass-bonded mica insulating materials.
4. The MYCALEX CORPORATION OF AMERICA has behind it over 20 years of research leadership, dating back to work done by the original MYCALEX (PARENT) COMPANY, LTD. of Great Britain, from which it obtained its American patents. MYCALEX CORPORATION OF AMERICA owns U. S. patents and patent applications on improved glass-bonded mica insulation marketed under the trade-mark "MYCALEX."
5. The products of MYCALEX CORPORATION OF AMERICA are: (a) "MYCALEX 400"—the most highly perfected form of MYCALEX, approved by the Army and Navy as Grade L-4 insulation. MYCALEX 400 is sold in sheets, rods and fabricated form. (b) "MYCALEX K"—an advanced capacitor dielectric with a dielectric constant of 10 to 15, which can be fabricated to specifications. (c) MOLDED MYCALEX available to specifications in irregular shapes and into which metal inserts may be incorporated.
6. "MYCALEX" in the forms described above is made by exclusive formulae and exclusive patented processes. It is utterly impossible for any one other than the MYCALEX CORPORATION OF AMERICA to offer any product, similar in appearance, as "the very same thing."

**MYCALEX CORPORATION of AMERICA**

*"Owners of 'MYCALEX' Patents"*

Plant and **CLIFTON,**  
General Offices: **NEW JERSEY**

Executive Offices: 30 **ROCKEFELLER PLAZA**  
**NEW YORK 20, N. Y.**

COMMUNICATIONS FOR NOVEMBER 1944 • 25





*History of Communications. Number Nine of a Series*

## MILITARY COMMUNICATIONS BY TELEPHONE



During the Spanish-American War the telephone as a means of electronic voice communication met with favor and played a vital part in military action for the first time. Replacing men and horses, a telephone message could cross and recross enemy territory by wire without delay and cost of life.

Today, telephones in the office and home life of the average American have been an instrumental force in our higher standard of living.

Universal, manufacturing microphones and other voice communication components for the allied forces, will again after Victory is ours, stock dealers' shelves with the Universal components you have been waiting for. Until then — *Buy War Bonds.*

*Model T-45, illustrated at left, is the new Lip Microphone being manufactured by Universal for the U. S. Army Signal Corps. Shortly, these microphones will be available to priority users through local Radio Jobbers.*



**UNIVERSAL MICROPHONE COMPANY**  
INGLEWOOD, CALIFORNIA



FOR TOUGH MILITARY CONDITIONS

# Sperti HERMETIC SEALS

**IMPROVED TYPE!** Seal out dust, moisture and fungus from transformers, relays, vibrators and other sensitive component parts.

**FUSED INTO ONE PIECE.** Glass-to-metal vacuum tight hermetic seal. Resists corrosion. Thermal operating range of  $-70^{\circ}\text{C}$  to  $200^{\circ}\text{C}$ . Insulation leakage resistance, 30,000 megohms, minimum, after Navy immersion test.

**SOLDERING TEMPERATURE NOT CRITICAL.** Simple, easy to attach by means of high frequency, oven-soldering or standard soldering iron.

**WRITE, WIRE OR PHONE TODAY** for information. Complete details will enable us to make specific recommendations and send appropriate samples.

NOW IN

*Volume production*

**Sperti** INCORPORATED



Electronic Division,  
RESEARCH • DEVELOPMENT • MANUFACTURING  
CINCINNATI 12, OHIO



# Forward

## WITH THE 6<sup>TH</sup> WAR LOAN!

Official U. S. Marine Corps Photo

### *Keep Your Plant's Quota* "OUT FRONT!"

Victory depends upon materials—as well as men! To keep our American forces "closing in" overseas, you and every other manufacturer here at home must keep on making "Out Front" War Bond Quotas!

This means *action now* on every point in the fighting 8-Point Plan to step up Payroll Deductions. For instance, have you a 6th War Loan Bond Committee, representing labor, management and other important groups in your company? Selected Team Captains

yet—preferably returned veterans? If so, have you instructed them in sales procedure—and given each the Treasury Booklet, *Getting the Order?*

How about War Bond quotas? Each department—

and individual—should have one! Assigning responsibilities is vital, too! Have you appointed enough "self-starters" to arrange rallies, competitive progress boards and meeting schedules? Are personal pledge, order or authorization cards printed, and made out in the name of each worker? Planning for resolicitation near the end of the drive? Your State Payroll Chairman is ready now with a detailed Resolicitation Plan. And, have you contracted for space in *all* your regular advertising media to tell the War Bond story?

Your positive *Yes* to *all* points in this forward-to-victory 8-Point Plan assures your plant meeting an "Out Front" Quota in the 6th War Loan—and speeds the day of unconditional surrender!

*The Treasury Department acknowledges with appreciation the publication of this message by*

## COMMUNICATIONS

*This is an official U. S. Treasury advertisement—prepared under the auspices of Treasury Department and War Advertising Council.*



# "MEET YOUR NAVY"

Now Carries the RAYTHEON Name  
Into 3,500,000 Radio Homes Each Week!

- ★ ACTUAL BATTLE EXPERIENCES
- ★ 65 BLUEJACKET MUSICIANS

- ★ 200 BLUEJACKET VOICES
- ★ TALENTED BLUEJACKET SOLOISTS

RAYTHEON MANUFACTURING COMPANY • Newton and Waltham, Massachusetts

*Every Saturday Night*  
**BLUE NETWORK**  
*Coast-to-Coast*

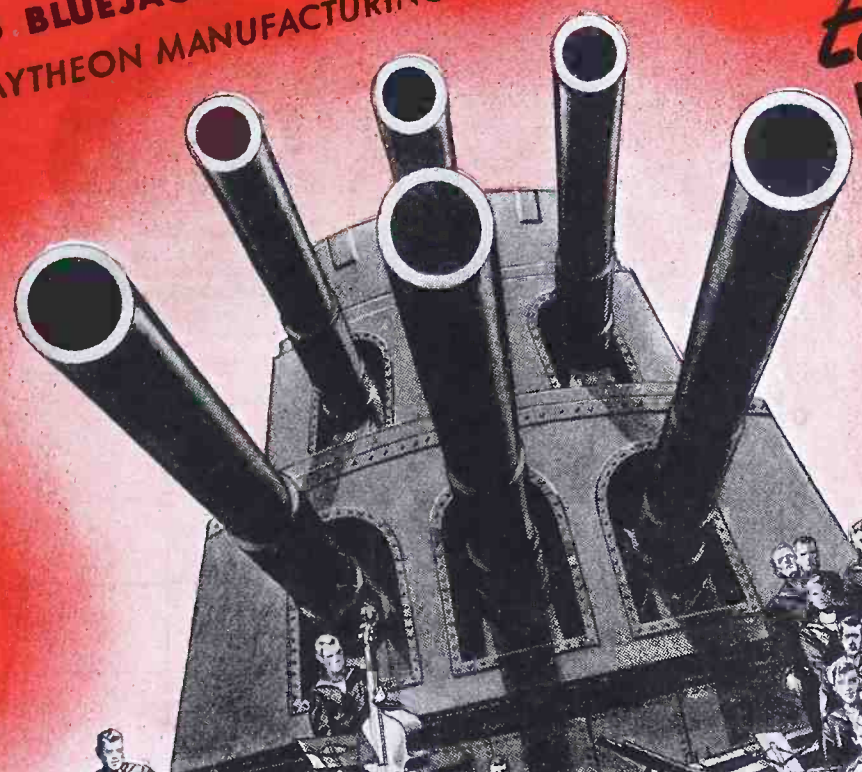

All Four Raytheon Divisions Have Been  
Awarded Army-Navy "E" Plus Stars



**RAYTHEON**  
*High Fidelity*  
RADIO AND ELECTRONIC TUBES



DEVOTED TO RESEARCH AND THE MANUFACTURE OF TUBES AND EQUIPMENT FOR THE NEW ERA OF ELECTRONICS

LOW PASS (TYPE L.P.I.)  
HIGH PASS (TYPE H.P.I.)

# FILTERS

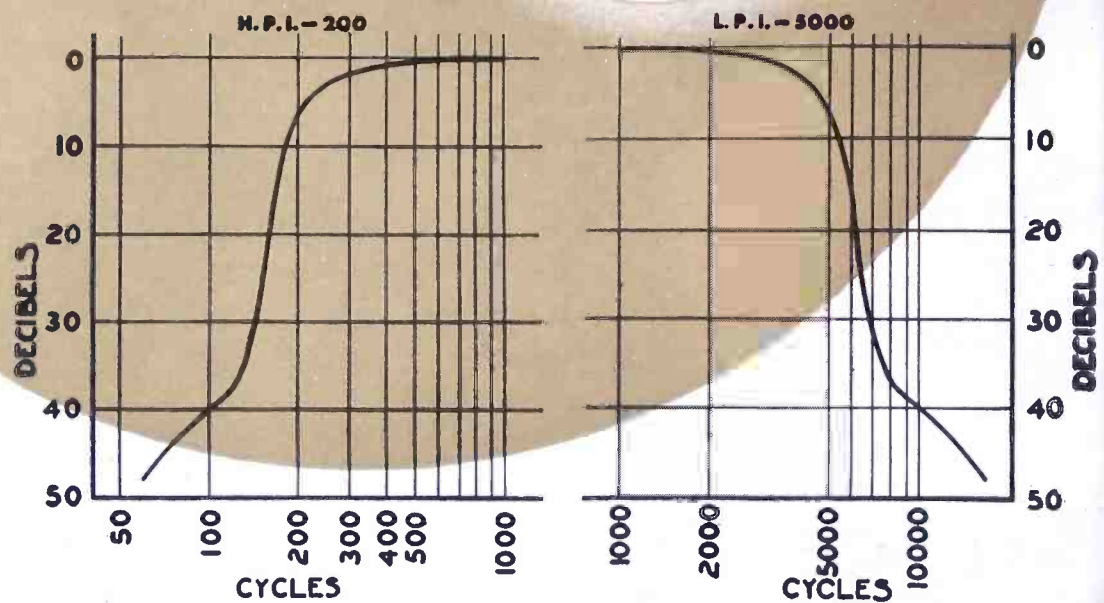
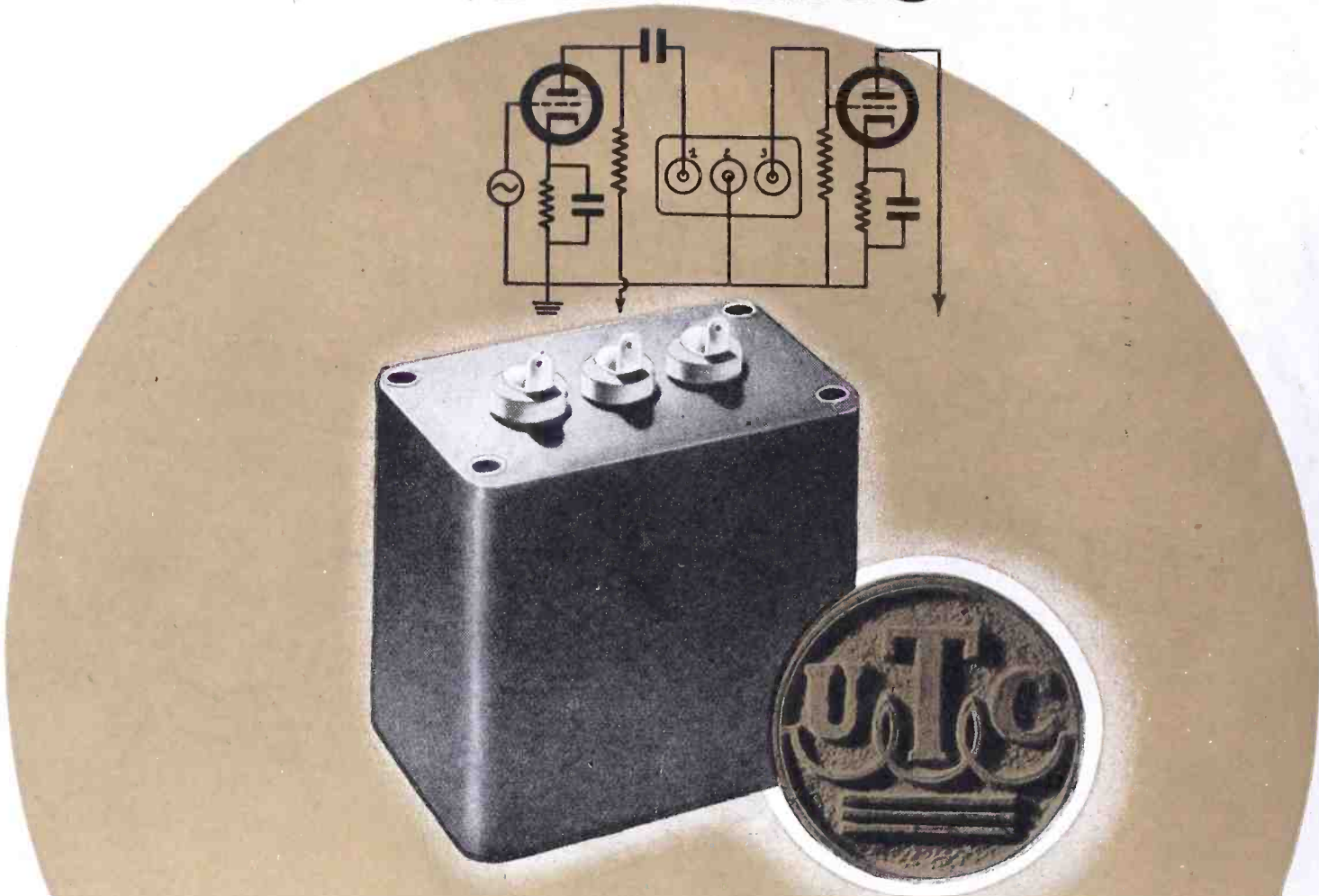

New additions to the UTC Interstage Filter family are now available in the type HPI and LPI units, respectively high pass interstage and low pass interstage filters.

The units are designed with a nominal impedance of 10,000 ohms to be used in a circuit as illustrated. Typical curves obtainable are shown above. Loss at cutoff frequency is less than 6 DB. At .75 times cutoff or 1.5 cutoff frequency respectively, the attenuation is 35 DB, and at one-half or twice cutoff frequency respectively, the attenuation is 40 DB.

These units employ a dual alloy magnetic shield which reduces inductive pickup to 150 Mv. per gauss. The dimensions in hermetically sealed cases are 1½" x 2½" x 2½". Filters of the HPI and LPI type can be supplied for any cutoff frequency from 200 to 10,000 cycles. Specify by type followed by frequency, as: LPI-2500.

*May we cooperate with you on design savings for your application . . . war or postwar?*

*United Transformer Co.*

150 VARICK STREET

NEW YORK 13, N. Y.

EXPORT DIVISION: 13 EAST 40th STREET, NEW YORK 16, N. Y.. CABLES: "ARLAB"



THE BRICKS ARE OLD...



The Ideas are New

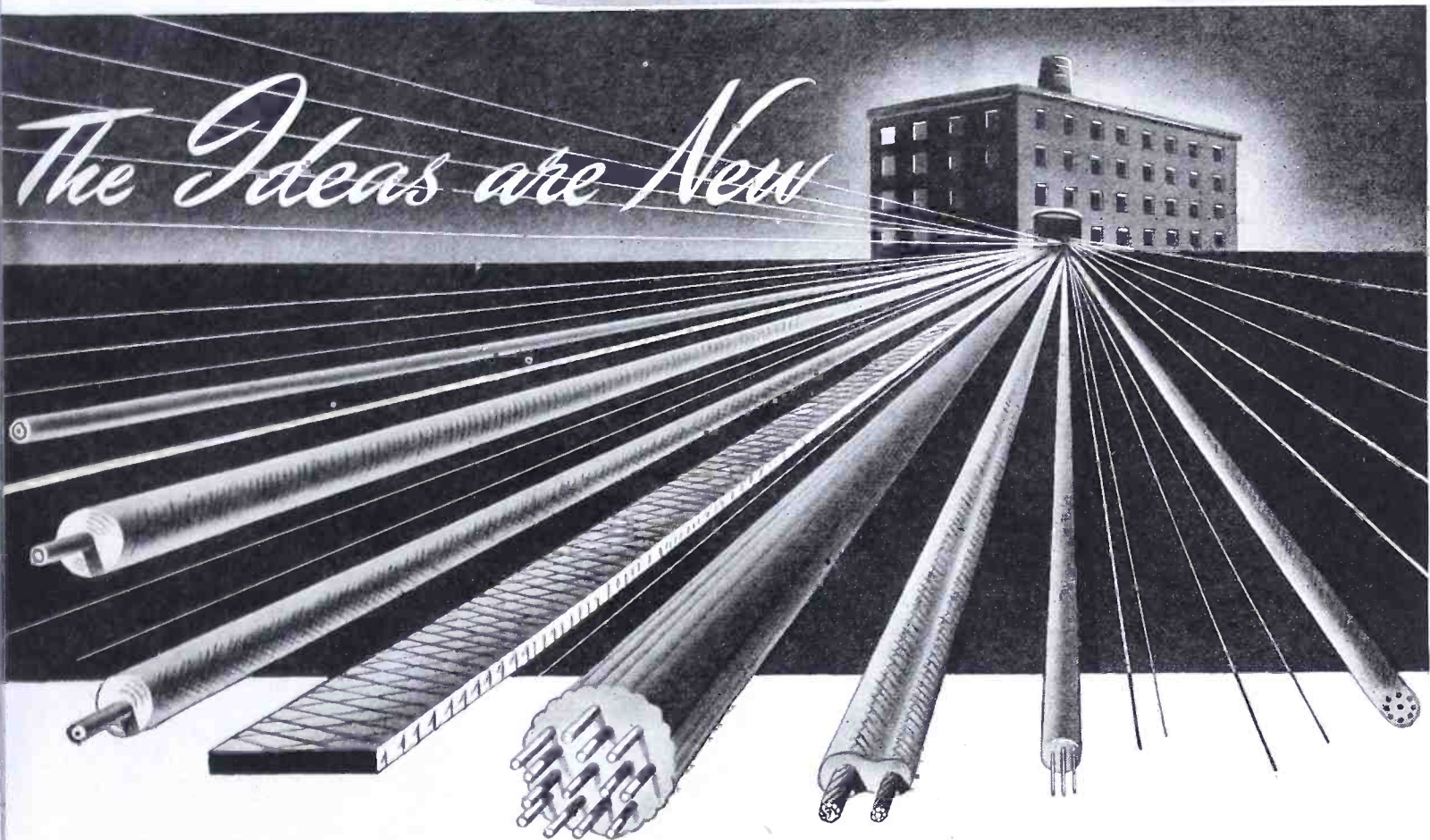

THE true power of America is not, as our enemies thought, in our great factories, our natural resources... it is in the know-how to meet new situations in new ways... summed up in a phrase known throughout the entire world — "Yankee Ingenuity!"

At Ansonia, for example, war found us with no experience in making cables of the exact type required by the Army and Navy, with their unique specifications. Yet we have produced them in staggering quantities — which, like their exact nature and use, must remain secret. But we can say that re-

quirements were not only met but that one new and particularly vital kind of cable was first produced here at Ansonia — in an old brick building typical of the Naugatuck Valley. This type of thinking and action continues to be available to our forward-looking government in war, to industry in peace.

**ANKOSEAL** multi-conductor insulated cables are among the most promising of Ansonia war-proven developments. If you have, or expect to have, a use for electrical cables—

CHECK ANKOSEAL!

**THE ANSONIA ELECTRICAL COMPANY**

Specializing in "Ankoseal" a Thermoplastic Insulation  
ANSONIA • CONNECTICUT



A Wholly-Owned Subsidiary of

**NOMA ELECTRIC CORPORATION**

GENERAL OFFICES • NEW YORK, N. Y.

—In peacetime makers of the famous Noma Lights—the greatest name in decorative lighting. Now, manufacturers of fixed mica dielectric capacitors and other radio, radar and electronic equipment.

Skilled hands *seal-in* the original precise characteristics of Hammarlund variable capacitors so that moisture and vibration can not change them — even after long periods of operation in all sorts of climates and under varied working conditions.

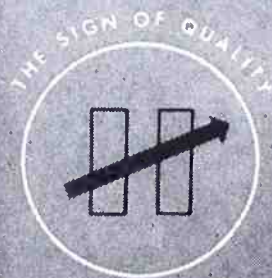

ESTABLISHED 1910

# HAMMARLUND

THE HAMMARLUND MFG. CO., INC., 460 W. 34<sup>TH</sup> ST., N. Y. C.  
MANUFACTURERS OF PRECISION COMMUNICATIONS EQUIPMENT



# COMMUNICATIONS

LEWIS WINNER, Editor

\* \* NOVEMBER, 1944 \* \*

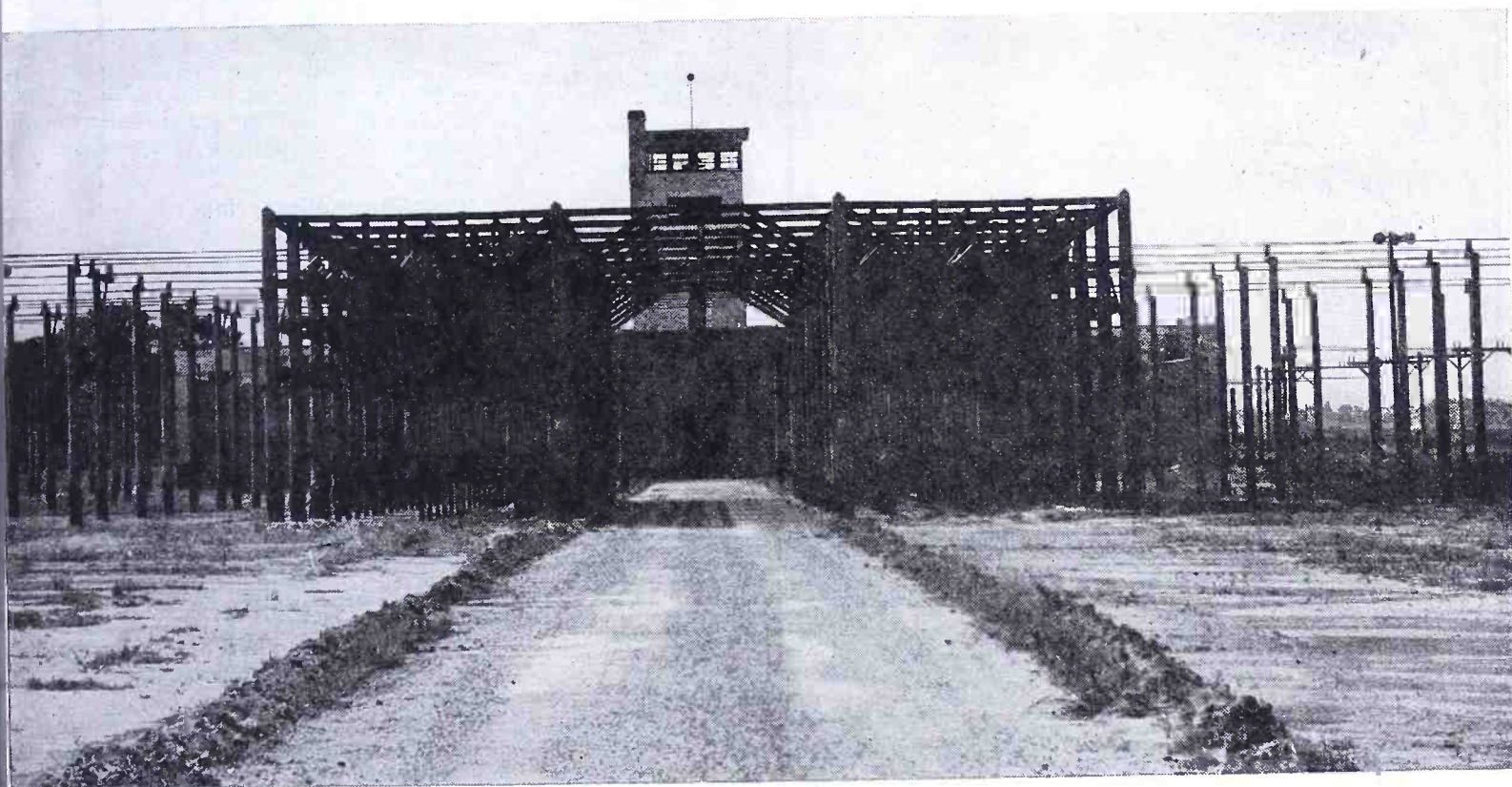

## HOWI 200-KW H-F TRANSMITTERS AT BETHANY, OHIO

by R. J. ROCKWELL

Director of Broadcast Eng.  
The Crosley Corporation

ON September 23, 1944, the Office of War Information, the Office of the Coordinator of Inter-American Affairs and the Crosley Corporation officially dedicated three new 200-kw transmitters at Bethany, Ohio.

This was the culmination of almost two years of planning, designing and building, of invention and adventure in the field of radio engineering. This was the end of a trail that started with an urgent war necessity, and the beginning of another trail that leads forward to a new kind of *air supremacy* for the United States of America. This was *the loudest voice in the world* trying its young lungs.

On that fateful December Sunday in 1941, when bombs rained down on Pearl Harbor, Uncle Sam was internationally inarticulate, as compared with the enemy. Six international licensees were operating only 13 short-wave stations, several of which were incapable even of 50-kw output. In contrast to this, Germany had

at least 68 short-wave transmitters under her control, and it was reported that from 12 to 20 additional units of 200-kw output might be in operation by December, 1942. Japan controlled 42 known transmitters, ranging up to 50 kw. Thus, the Axis was able to carry the same program on as many as 20 different frequencies. In fact, Germany's regular service to the Americas was then using 16 frequencies.

### Illustration Above

A view of the main antenna switching station with transmission lines leading to the antenna.

By the most conservative estimates, we needed at least 36 international transmitters, operating on a total of 70 frequencies between 6 and 20 mc, with powers ranging up to 200 kw, if possible. But that was a big *IF!* For, at that time, no vacuum tubes, output circuits or antennas which were capable of such powers were known to exist.

In a drastic effort to remedy the situation, the Board of War Communications called a *council of war* in Washington. All interested parties were invited—international licensees, equipment manufacturers, representatives of the Federal Communications Commission, Office of War Information, Office of Coordinator of Inter-American Affairs, the Department of State, and others—to determine how soon existing facilities could be augmented and new facilities added, and what powers could be attained. As a result of this and subsequent meetings, it was decided that, within one year, a total

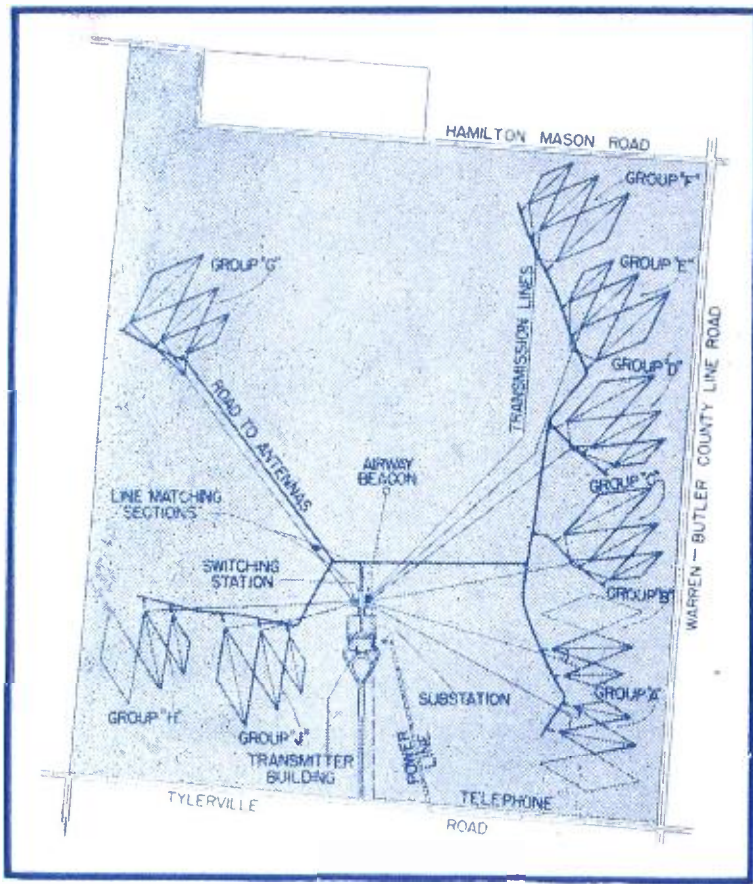
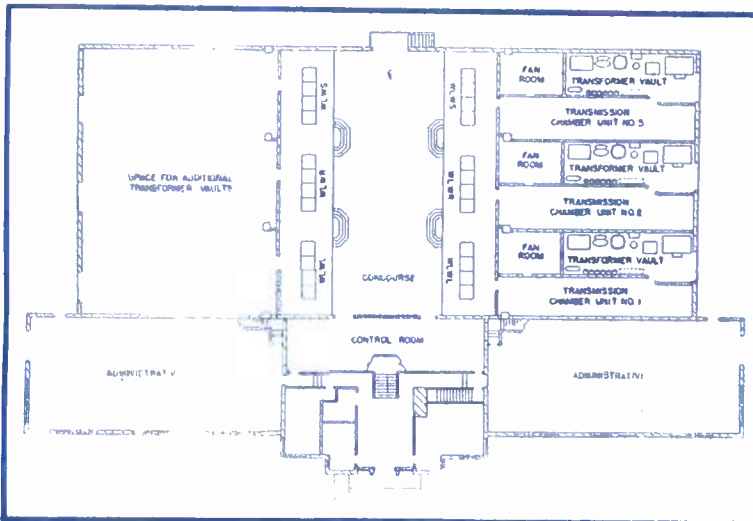
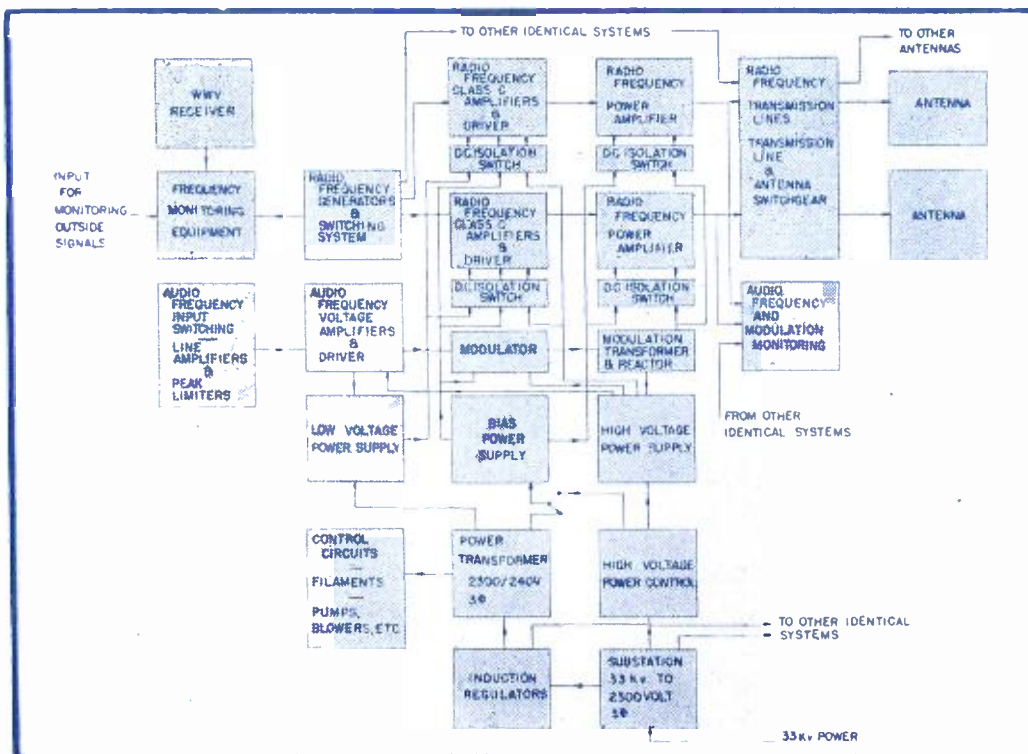

Figure 1  
A general layout of the property where the 200-kw transmitters are located, with building, substation, switching station and antenna system.



Figures 2 (left) and 3 (below)  
Figure 2, floor plan of the transmitter building, showing the fireproof vaults where the high voltage transformers, filter reactors, filter condensers, and high voltage control components are placed. Figure 3, block diagram of the complete transmission system.



of 32 transmitters could be in operation and at the disposal of OWI and CIAA. It was felt that installations could be greatly expedited by duplicating existing maximum power output, which was 100 kw, and required operation of tubes in parallel to achieve even this power.

But, to be on a parity with the Axis, and to be able to override interference and cope with inferior receiving conditions in foreign countries, we had to do more than just duplicate existing powers; we had to exceed them, we had to double our greatest previous powers!

As a part of this mammoth program, the Crosley Corporation undertook to re-design its equipment, for an output of 200 kw. Tubes were designed and developed, circuits were calculated, and antennae were devised to do the job. This paper will describe the installation in some detail, and tell of its operation.

### High Power Pioneering

The story of Bethany really goes back far beyond Pearl Harbor. In the very early days of high-power, high-frequency broadcasting, when 10 kw was the power maximum, Crosley's W8XAL was a pioneering leader. Always experimenting with higher powers, its staff had already built a 50-kw transmitter when FCC made that output a license requirement. Through continuation of these experiments, tubes were developed capable of 75 kw, and in 1940, another momentous dedication was held, of the most powerful short-wave station in this country at that time, WLWO.

Even in the standard band, Crosley had pioneered in high power. Its world famous W8XO, on the WLW frequency of 700 kc, had operated successfully for several years prior to the war with 500-kw power. And even today, the unmodulated signal of W8XAL serves the U. S. Bureau of Standards, providing a variety of information on radio skywave transmission, notably on absorption and its variation. From measurements of this type, the Bureau supplies OWI with advance information which enables them to schedule optimum usable frequencies for all American international stations for various times of day, season and solar cycle.

Because of these qualifications, as well as the fact that Crosley's offer to construct the three 200-kw transmitters did not conflict with urgent military orders, this responsibility was placed in the hands of the Crosley Corporation by OWI. Moreover, since at the time the decision was made, it was still considered a possibility that bombings of the East coast might be attempted by Germany, a middle-west location was desirable for security reasons.

### Selecting a Site

Once the basic plan was evolved, the first big problem was the selection of a site on which to build the project. The specifications were extremely exacting. About a section of land was required for the building, switching station and 24-rhombic antennae. And it was necessary to leave some space for future expansion without overcrowding. The ground had to be as high, or higher, than surrounding territory, and relatively level throughout and for some distance beyond. A uniform slope under and ahead of the

antennas in the direction of transmission was needed, in order to lower the angle of maximum radiation of the high frequency, directional radiators. The land had to be virtually free of wooded or populated areas for a considerable distance. A source of 3000-kva primary power was required, as well as provision for broadcast type telephone circuits, leading from the master control room of WLW in Cincinnati.

The Bethany site was chosen only after thorough studies had been made of U. S. topographical maps covering a radius of about 50 miles around Cincinnati, and after every other possible site had been investigated. It is slightly less than a full section of high, relatively flat land, gently sloping generally in all directions from center, and the surrounding land is also flat and slopes slightly in favorable directions. The area is remarkably free from housing, and the few slightly wooded areas could easily be avoided in layout.

The same dual-power circuit feeding the WLW, WLWO and WLWK transmitters near Mason, Ohio, passes along the southern boundary of the property, and the telephone cables for those stations run along the eastern boundary. Thus expense, and use of critical materials, could be held at a minimum, in obtaining these vital services. Two rail lines are within a few miles of the place, and a good hard surface road runs past the south entrance to the property, while satisfactory all-weather roads skirt the east and north boundaries. This was of considerable importance, due to the physical size of some of the components of the project, such as antenna poles, transformers, etc., which had to be transported to the site.

Figure 1 shows a general layout of the property, with building, substation, switching station and antenna system indicated and identified.

### Tailoring the Transmitter Building

The building is composed of two separate units, an administrative section and a transmitter section. Although, due to the character of the design, there is an expansion joint between these sections, the two are actually one building.

Since this paper deals primarily with the transmitters, concentration will be on the details of that section, and the administrative portion will be dismissed with the information that it is two stories high, with a four-story central tower that serves as a guard station and revolving searchlight beacon house. Offices and living quarters for resident engineers, a machine shop and a garage occupy the two stories of the building itself, while the first three levels of the guard tower contain radio-testing equipment, a storage tank for distilled water used in tube cooling, and two 1500-gallon water storage tanks for general building purposes.

The transmitter section is entirely functional. It was designed to accommodate six transmitters with their associated equipment, and is actually six similar units, three on each side of a center concourse. This section is a monitor type building 175' wide by 75' long, with a high bay measuring 24' from floor to roof slab. Ceiling height in the side bays is 17'. This section contains some interesting features. A tunnel extends under the center of the concourse, connect-

Figure 4  
View of a section of the transmitter. Unit, third from left, is r-f driver, which operates at carrier frequency throughout; range is 6 to 22 mc.

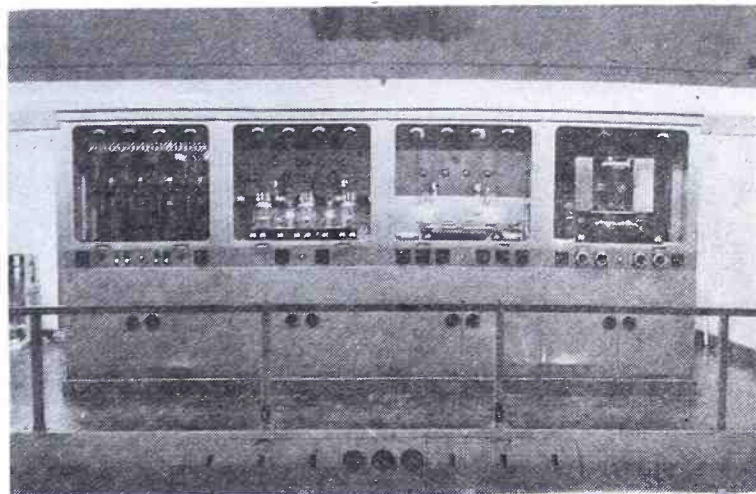

Figure 5  
Rear view of one of the r-f generators. Shield has been removed from second buffer stage coil to show construction.

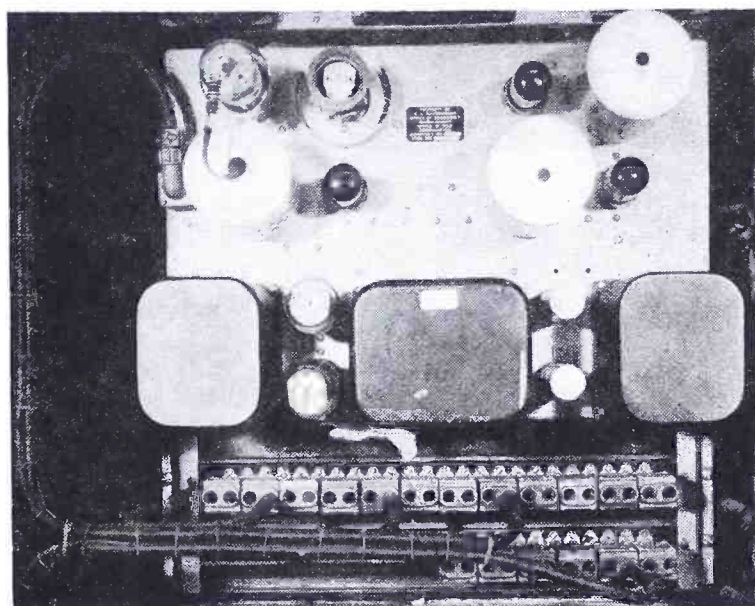

Figure 6  
Partial view of the equipment bays in which the r-f units are mounted. Note coaxial patching panels. R-f generator front panel has been removed to reveal internal construction.

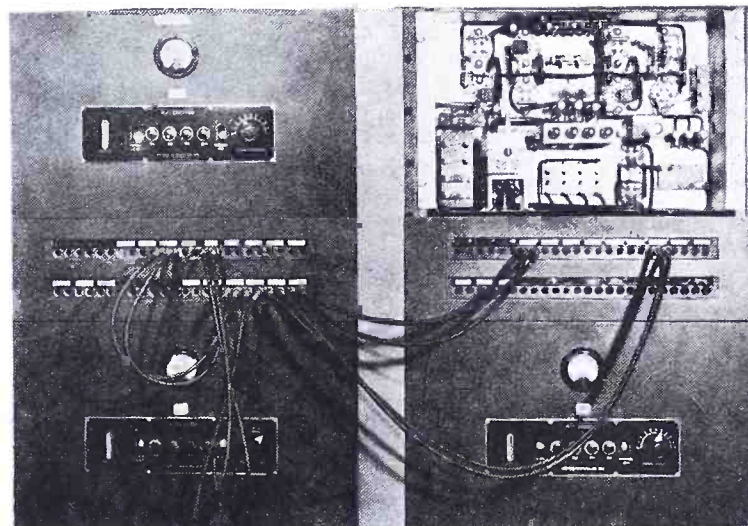
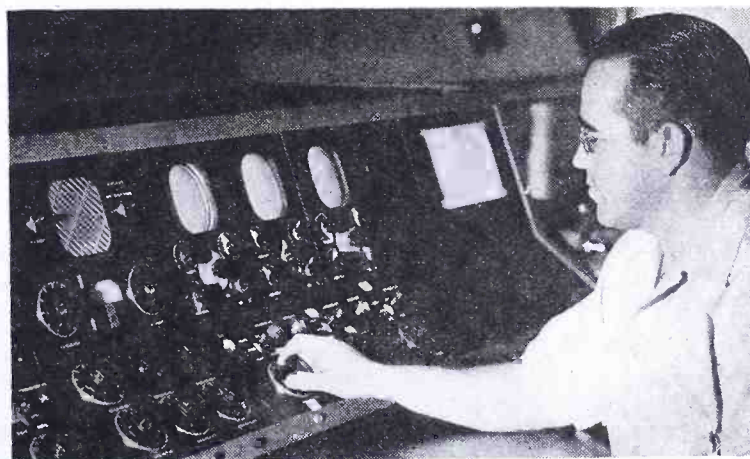
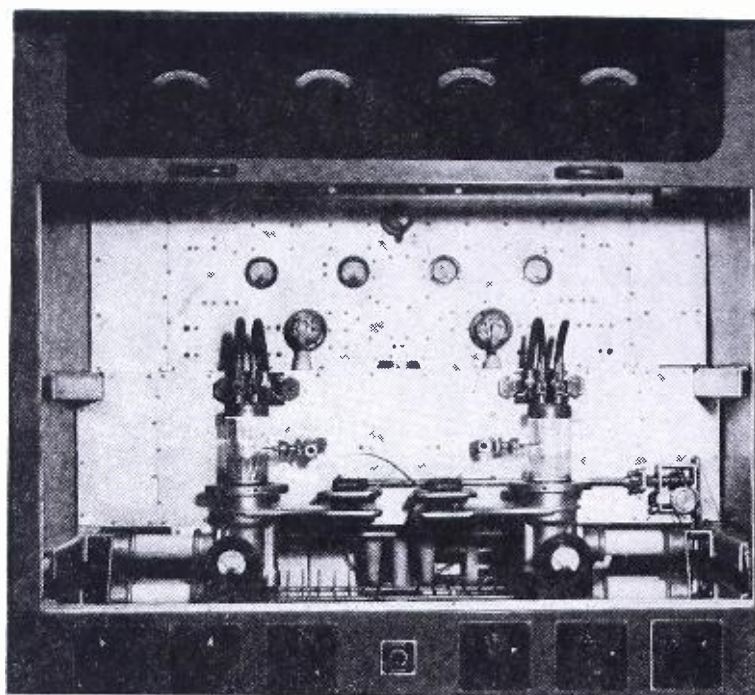

Figure 7  
Cathode-ray oscilloscopes used for monitoring carrier of each transmitter. These are mounted in the control desk.





Figures 8 (left) and 9 (right)

Figure 8, front view of the r-f driver which is composed of three stages. Each stage is separately tuned in both grid and plate circuits, and is link-coupled to the succeeding stage. Figure 9, output coupling adjustment, which is completed by swinging a small link coil into the field of the center of the driver plate inductance.

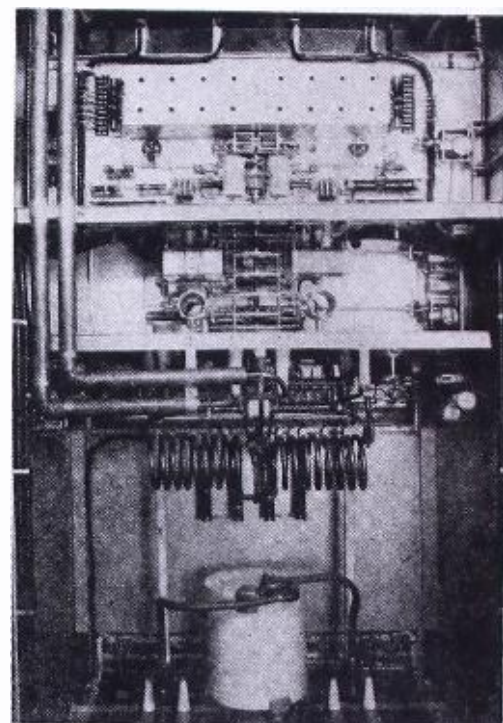

ing with the boiler room under the administrative section, and provides cross-connecting facilities for the transmitters on either side. To permit the extraordinary flexibility for piping and wiring required in this installation, a cellular steel floor was set between two mats of concrete, the upper layer being the floor of the concourse. This steel *Q-floor* extends from the sides of the tunnel walls to the undersides of the transmitter catwalks.

Another unusual design feature is its cantilever construction. The high bay has a span of 64' between column supports. The monitor width of the high bay is 99'. To reduce the depth of the girders supporting bay beams, 17' 6" cantilevers were designed on the outside of the columns, to support the extension of the monitor beyond the column centers. This cantilever action produced negative moments in the center of the span, permitting a reduction of the beam depth of the girders bridging the high bay. The roof slab of the side bays is suspended from the bottom level of the cantilevers, producing a design in which only three spans are necessary to bridge a total distance of 175', and which, at the same time, accomplishes the difference in ceiling heights incident to monitor-type roof construction.

The transmitter section interior consists of the center concourse, flanked by catwalks, on which are mounted six transmitter units. Directly behind these units is a continuous wall, in which is mounted, behind each individual unit, a group of cabinets which include 240-v power distribution panels, magnetic switch panels, automatic air control equipment, etc. Beyond the wall to the rear are individual fan rooms, in which are cooling fans, water pumps, and plenum chambers for distributing inlet and heated air as described later. Directly behind these fan rooms are the transformer vaults. Under the catwalks are the filament transformers, and plumbing for distributing the water to water-cooled tubes. On the slanted front edge are water-flow meters, temperature gauges, and water controls, Figure 4.

The entire building is thoroughly grounded, a mat of wires radiating on all sides for a distance of 50', and extending to the reinforcing bars which are welded together within the concrete. This was

done to eliminate the possibility of cross-modulation, and to provide a good ground matting for the transmitters.

### The Transmission System

A general over-all picture of the complete transmission system appears in the block diagram of Figure 3. The diagram shows one complete transmission system with its three essentials: primary power, r-f power, and a-f power, separately obtained and combined into high power modulated r-f energy, which is radiated by the antenna system.

Radio frequency at carrier frequency is generated continuously on all frequencies assigned to this plant. Separate 15-watt exciters for each frequency are mounted, six to a bay, in the control room. Exciter power is fed to the transmitters through a plug and jack panel, using multiple, double conductor coaxial lines and jacks.

The r-f driver unit, third from the left in Figure 4, operates at carrier frequency throughout. Its range is 6 to 22 mc. Input power from the exciters is from 2 to 5 watts. A maximum output power of 10 kw can be obtained from this unit, which is coupled, through an adjustable link, to the power amplifier in the adjacent cabinet to the right.

The modulated class C amplifier employs two tubes, operating push-pull, capable of 200-kw carrier output. Conventional lumped constant circuits are used in the grid, while the plate circuit consists of a lumped variable capacity, and a shorted transmission line section for the inductance. Variable inductive coupling is employed to transfer power to the antenna transmission lines.

The a-f circuits originate in the control room, where the modulating signal is taken from incoming telephone lines, or local electrical transcriptions. A transmitter circuit includes a limiting line amplifier, to amplify the audio voltage and compress high level peak; peak clipper to chop both positive and negative peaks at a pre-set level, usually equivalent to 100% transmitter modulation; and the usual level controls and volume indicators. From the control room, a-f voltage is fed at zero level to the modulator unit of the transmitter. The modulator contains three push-pull voltage-amplifier stages, and a multiple-tube class B power

stage, capable of delivering 180 kw of audio power. The modulation transformer, modulation reactor, and d-c blocking condenser are located in the transformer vault, and are connected to the modulator through high-voltage cables.

Primary power for these transmitters is derived from a substation at the side of the main building, and a stepdown transformer in the transformer vault. All rectifier tubes and their filament transformers are located in the rectifier unit of the transmitter.

The rectifier unit also serves as a control and supervisory unit for the entire transmitter. Momentary contact buttons, pilot relays, and supervisory relays and lights are mounted in the rectifier cabinet. All 240-v power contactors for filaments, low voltage supplies, etc., and a 240-v breaker and distribution panel are located in the wall cabinet behind the transmitter, as previously described. All equipment dangerous to personnel is completely interlocked, both electrically and mechanically.

### Antenna System

The antenna system consists of a transmission line from each of the six transmitter bays to a common transmission line switching system. In this gear, any transmitter line can be connected to any outgoing antenna line. All antennas are of the reentrant rhombic type.

Each transmitter is equipped with a complete and separate cooling system, which supplies water for water-cooled tubes, and ventilating air for general cabinet cooling. This system is so arranged that all waste power is converted into heated air, which is automatically used for building heat in winter. In summer, heated air is forced through roof ventilators, causing cool air to be drawn into the building. A 50-gallon-per-hour still in the boiler room and a 400-gallon storage tank in the guard tower, with a common feeder to all systems, supply the distilled water for cooling.

A complete system of modulation monitoring, by means of oscilloscopes, of audio monitoring by means of diodes on the transmission lines, and of frequency monitoring, by means of a secondary standard and WWV comparison equip-

(Continued on page 56)

# Specify

# C.T.C.

CRYSTALS

I-F TRANSFORMERS

TURRET TERMINAL LUGS

SPLIT LUGS

DOUBLE END TERMINAL LUGS

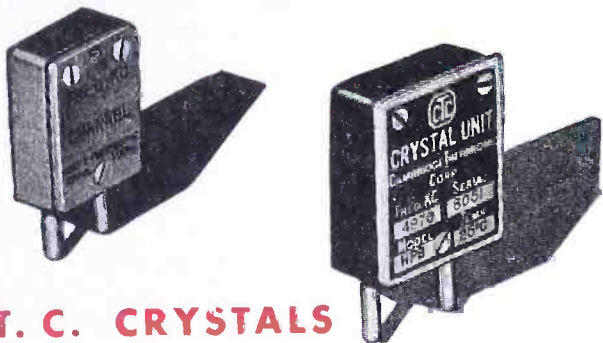

## C. T. C. CRYSTALS

Accurate cutting of each slice — thanks to X-RAY ORIENTATION — insures constant frequency over a wide temperature range. Multiple mechanical lapping operations; dimensioning by edge lapping and finishing to final frequency by etching, are other important steps in the manufacture of C.T.C. Crystals that guarantee high activity and constant frequency throughout their entire life.

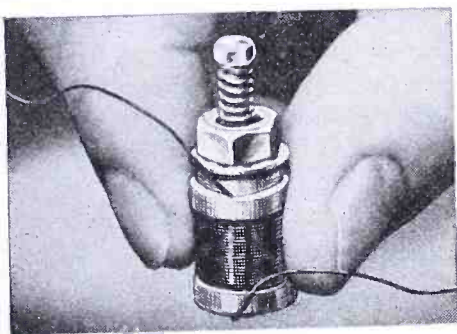

## I-F TRANSFORMERS

These tiny, ultra-high frequency, slug tuned I-F Transformers are doing an efficient, thoroughly dependable job in many important radio and electronic applications.

Ask us about LS-1 (pictured above actual size) and LS-2 transformers.

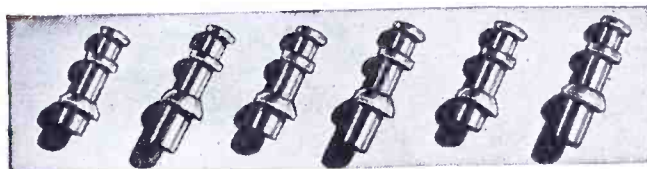

## C. T. C. TURRET TERMINAL LUGS

Just swage these heavily silver plated Turret Terminal Lugs to the board and in a jiffy you have a good, firm turret terminal. Quick soldering, too. Sufficient metal is used in the Lugs to give them strength but not enough to draw heat thus increasing soldering time.

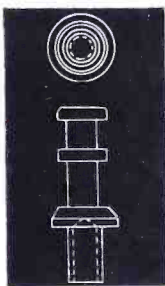

C. T. C. Turret Terminal Lugs are stocked to meet  $\frac{1}{32}$ ",  $\frac{2}{32}$ ",  $\frac{3}{32}$ ",  $\frac{4}{32}$ ",  $\frac{5}{32}$ ", and  $\frac{6}{32}$ " board thicknesses.

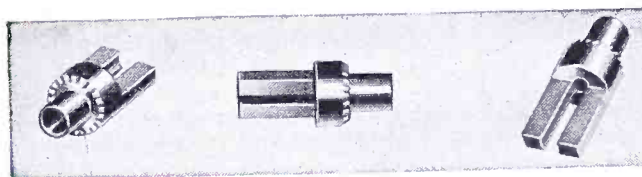

## C. T. C. SPLIT LUGS

A .050 hole through the shaft permits wiring to these Split Lugs from either top or bottom without drilling or cutting. Just swage them to the board, then wire. Made of brass, heavily silver plated, C. T. C. Split Lugs are available in two sizes to fit  $\frac{3}{32}$ " and  $\frac{5}{32}$ " boards.

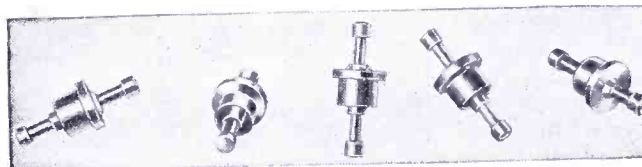
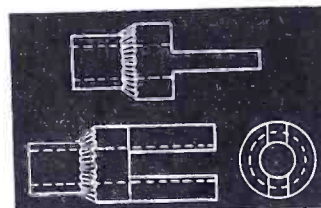

## DOUBLE END TERMINAL LUGS

Use these Double End Terminal Lugs when you need terminal posts on both sides of the board. Like C.T.C. Turret Terminal and Split Lugs, C.T.C. Double End Lugs simply swage to the terminal board — provide twin terminal posts which may be wired from top and bottom. Heavily silver plated brass. Stocked to fit  $\frac{3}{32}$ " terminal boards.

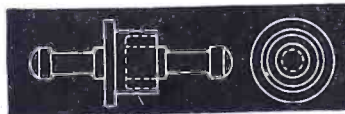

For complete information get in touch with

**CAMBRIDGE Thermionic CORP.**

**442 CONCORD AVENUE**

**CAMBRIDGE 38, MASSACHUSETTS**

# GRAPHICAL CAA COURSE

by G. L. BREWER

Chief, High Frequency Unit  
Signals Division, CAA

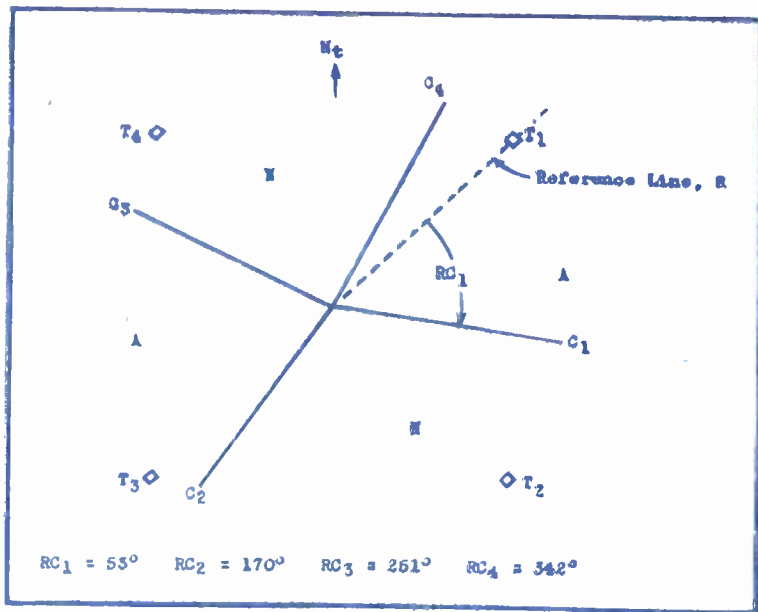

Figure 1  
First step in solution;  
drawing of towers and  
required courses, cor-  
rectly oriented.

**T**HIS paper describes a graphical method employed by the CAA for determining the adjustments necessary for properly orienting the four courses of a CAA radio-range station employing the modified Adcock antenna system.

The method discussed was introduced by the writer in 1938 to provide a simple and direct procedure whereby CAA personnel, especially those in the field, could pre-determine the correct adjustments of the radio equipment for producing the required courses. In the past it was necessary to solve the following simultaneous equations to secure these data:

$$\frac{I_1 + I_2 \tan \theta}{I_2 - I_1 \tan \theta} = \frac{\cos(a \sin A_1) \cos \frac{\phi_2}{2} - \sin(a \sin A_1) \sin \frac{\phi_2}{2}}{\cos(a \cos A_1) \cos \frac{\phi_1}{2} - \sin(a \cos A_1) \sin \frac{\phi_1}{2}} \quad (1)$$

$$\frac{-I_1 + I_2 \tan \theta}{I_2 + I_1 \tan \theta} = \frac{\cos(a \sin A_3) \cos \frac{\phi_2}{2} - \sin(a \sin A_3) \sin \frac{\phi_2}{2}}{\cos(a \cos A_3) \cos \frac{\phi_1}{2} - \sin(a \cos A_3) \sin \frac{\phi_1}{2}} \quad (2)$$

$$\frac{I_1 + I_2 \tan \theta}{I_2 - I_1 \tan \theta} = \frac{\cos(a \sin A_2) \cos \frac{\phi_2}{2} - \sin(a \sin A_2) \sin \frac{\phi_2}{2}}{\cos(a \cos A_2) \cos \frac{\phi_1}{2} - \sin(a \cos A_2) \sin \frac{\phi_1}{2}} \quad (3)$$

$$\frac{-I_1 + I_2 \tan \theta}{I_2 + I_1 \tan \theta} = \frac{\cos(a \sin A_4) \cos \frac{\phi_2}{2} - \sin(a \sin A_4) \sin \frac{\phi_2}{2}}{\cos(a \cos A_4) \cos \frac{\phi_1}{2} - \sin(a \cos A_4) \sin \frac{\phi_1}{2}} \quad (4)$$

Where:

- (a)  $A_1, A_2, A_3$  and  $A_4$  are the angles which the courses make with the reference line.
- (b)  $\theta$  is the goniometer angle in degrees.
- (c)  $I_1$  and  $I_2$  are the values of r-f current in the goniometer primaries. ( $I_1$  feeds towers  $T_1$  and  $T_3$  when the goniometer setting is zero.)
- (d)  $\phi_1$  is the phase difference between the voltages at towers  $T_1$  and  $T_3$ .
- (e)  $\phi_2$  is the phase difference between the voltages at towers  $T_2$  and  $T_4$ .

Many of the field engineers and electricians after spending considerable effort on the solution of the above equations for which there were no practical means of checking the results, resorted to the "trial and error" method. In order to aid this personnel, the graphical method was conceived and has proved a great aid in enabling the necessary data to be determined within a few minutes rather than hours, which was necessary in most cases, where the purely mathematical solution was employed.

**T**HIS paper treats only the subject of the graphical method for course alignment and does not attempt to describe the theory and operation of a radio-range station as

employed by the CAA since numerous previous presentations have discussed this subject in great detail.

### Graphical Method Features

By the use of the graphical method,

the following are determined:

- (a)—The goniometer setting.
- (b)—The electrical line length of the r-f transmission lines to each of the four sideband antennas.
- (c)—The ratio of the r-f currents in the goniometer primaries.

These data supply the necessary information for orienting the courses, although it should be realized of course that correct alignment of courses is also dependent upon proper tune-up and adjustment of all component equipments.

The graphical method solution is based on the following information:

- (a)—Tower bearings (measured clockwise from true north).
- (b)—Course bearings (true and toward station).
- (c)—Frequency (in kilocycles).
- (d)—Diagonal tower distance (in feet).

The first step toward the solution is the drawing of the towers and required courses, correctly oriented, as in Figure 1, with the signal identification letters noted in their respective quadrants. The towers are designated by the letter  $T$  with subscript numbers starting with a tower in an  $A$  quadrant, through which a reference line is drawn as  $T_1$ , and continue in clockwise direction as  $T_2, T_3$  and  $T_4$ . Likewise, the courses are designated by letters  $C$  with subscripts starting from the reference line and numbering in a similar clockwise direction. The angles measured from the reference line in a clockwise direction to the re-

For those who are not familiar with radio range systems, it is suggested that they review the paper by D. M. Stewart, Chief, Technical Development Division, CAA, entitled *Circuits Design for Low-Frequency Radio Ranges*. Although Mr. Stuart does not attempt to cover the operation of the radio range system, he does, in the first part, include sufficient information for the reader to understand the principle involved and the terminology employed.



# SOLUTION FOR ALIGNMENT

pective courses are designated as reference angles and denoted by the letter *R*.

## Bisecting Lines

The bisecting lines are shown in Figure 2 and are determined by bisecting the angle between the extension of one course of each pair of diagonally opposite courses and the associated course.

The bisecting line is extended on either side of the center and denoted by the letter *B* of the subscripts of the associated courses. In practice the actual geometrical construction is not required since the reference angles for these bisecting lines can easily be computed and inserted by using a protractor. For example, the smaller reference angle is obtained by using the equation

$$RB_{1-3} = \frac{RC_1 + RC_3 - 180}{2}$$

## Goniometer Setting

To determine the goniometer setting, a line (called *Goniometer Line*) is drawn radially from the center bisecting the angle between the bisecting lines, which places the *Goniometer Line* in an *A* quadrant. The reference angle of this line in degrees is the goniometer dial setting. This method yields two solutions which are 180° apart, both of which are correct.

The following rules govern whether

Figure 2  
Bisecting lines, determined by bisecting angle between extension of one course of each pair of diagonally opposite courses and associated course.

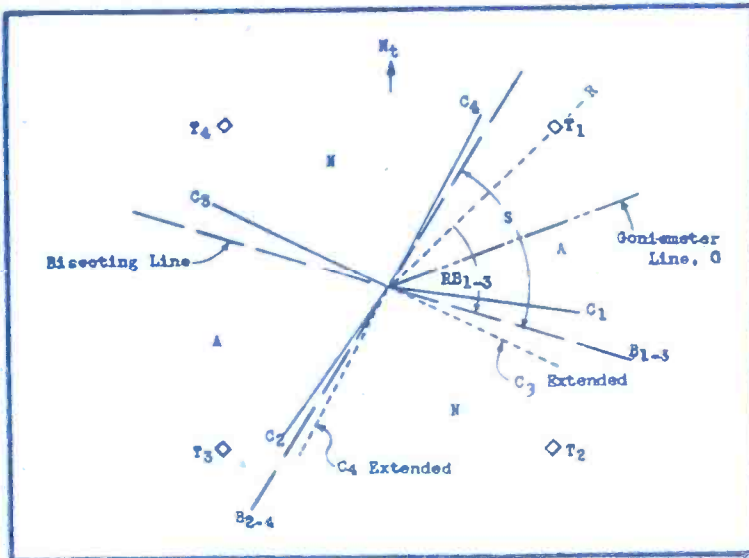

course bending, course squeezing, or both are required:

- (a)—If opposite courses are not 180° apart, course bending is required.
- (b)—If the bisecting lines are not perpendicular to each other, course squeezing is required.

## Course Squeezing

[Charts referred to in following text will appear in December]

The smaller angle subtended by the bisecting lines (angle *S* in Figure 2) is referred to chart 1 and the ratio of primary currents determined. The smaller current is for the goniometer primary having the same signal identification letter as the smaller quadrants.

The angle of bend (*E* in Figure 3) for a pair of courses is the angle between either course and the corresponding bisecting line. The angle of bend for one pair of courses is referred to chart 2 and the bending effect, *L*, thus determined. A vector is drawn (length proportional to *L*) radially from the center, perpendicular to the associated bisecting line, and on the

same side of the bisecting line as the associated courses, as in Figure 3. A perpendicular construction line is then drawn at the end of this vector. The same operation is performed for the other pair of courses. At the intersection of the two perpendicular construction lines *O*, a line is drawn to each of the adjacent tower's center lines and perpendicular to the latter. (Should only one pair of courses require bending, the intersection *O* will necessarily fall upon one of the unbent courses).

The scaled distances from the center to these intersections on the tower lines, using the same scale as for vectors *V*, represent the number of electrical degrees of line length that is added to the optimum line length for the respective towers. The opposite towers will have the same value of line length subtracted from the optimum value.

The units for the above results are in electrical degrees. For producing the departure from optimum line length, the above results are referred to the manufacturer's data for the par-

Figure 3 (left, below) and 4 (below)  
Figure 3, angle of bend *E* is shown here. Figure 4, graphical method used to determine *L<sub>G</sub>* and angle *A*.

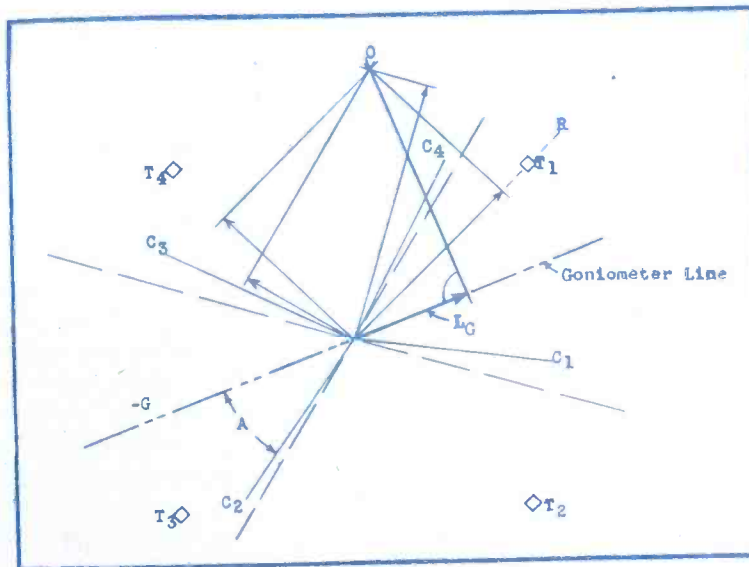
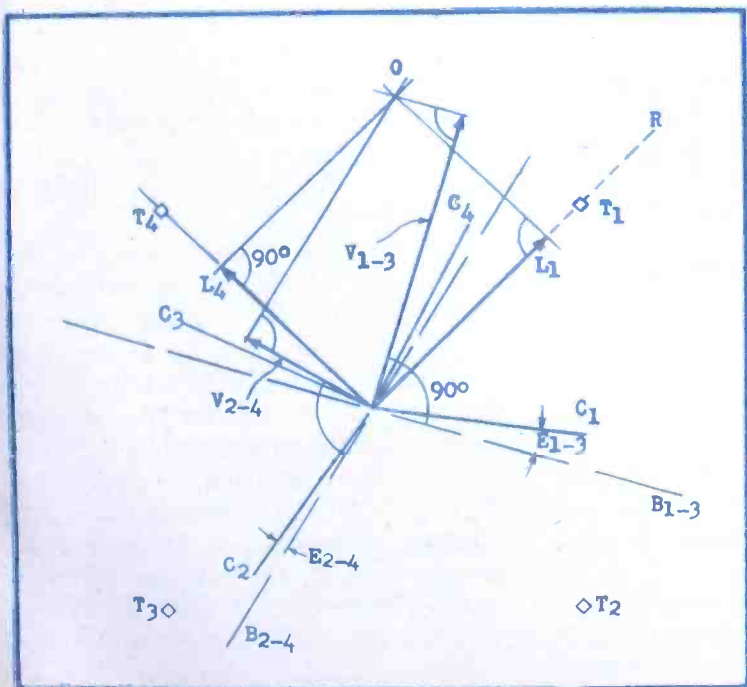

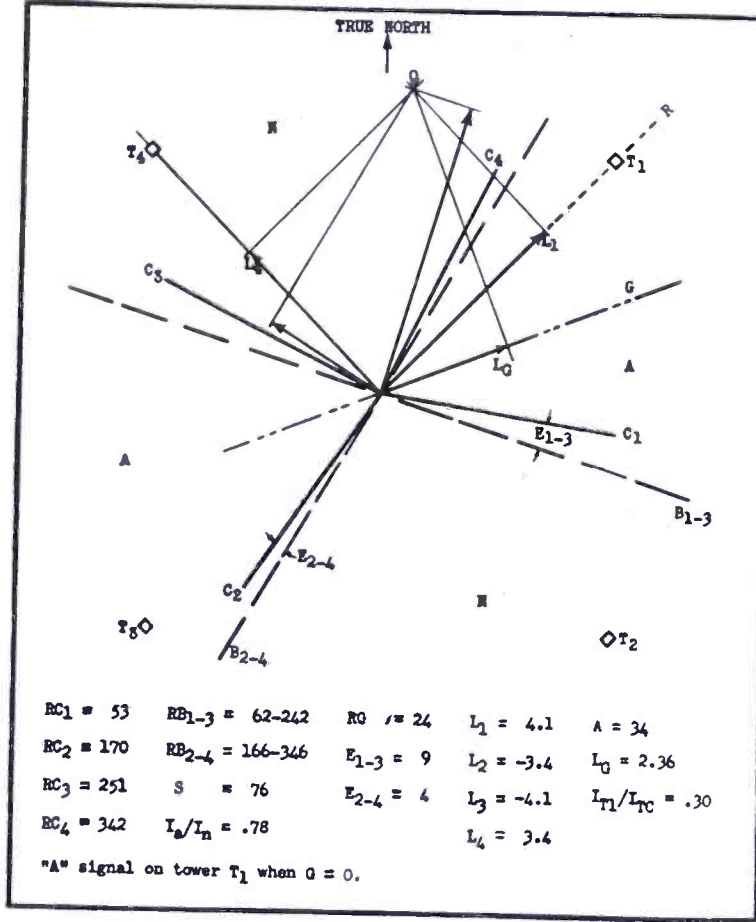

Figure 5

Sample work sheet showing all construction lines for a typical graphical solution. The magnetic declination is 5° W; tower distances, 600' diagonal; frequency, 300 kc; courses, 35, 116, 207 and 278 (true azimuth and toward station); tower bearing 225° (true azimuth and toward center tower).

ticular artificial lines used and the equipment adjusted accordingly.

This method has an error of approximately 1.5° in orientation of the courses under certain conditions where both extreme shifting and bending exists. For alignments of moderate shifting and bending the average error is less than one-half degree orientation. As other errors are prevalent in actual alignments of courses, this error becomes negligible for initial alignments.

The graphical method can also be used during actual alignment of courses in the field. Numerous times the courses are not correct after the first attempt of setting the courses. The corrections required to bring the courses into proper position can be obtained by the following procedure: The courses that were produced, although incorrect, are used for working another solution. The difference between the results obtained from this second solution and the original solution which produced the incorrect courses, indicates the correction that must be applied to the original solution. These corrections are applied to the original solution in a direction opposite to that of the difference be-

tween the original and second solutions. For example, if the original solution gives a goniometer setting of 25°, the second solution based on the courses as found gives a goniometer setting of 27°; the correction is minus 2° and the setting for final adjustment is 23°.

This procedure, however, is only used to compensate for small inherent errors in the equipment, radiation, and terrain conditions. Large discrepancies usually indicate improper adjustment of the r-f circuits in the transmitter, coupling units, or antenna system. It is obvious that these errors cannot be rectified by the above procedure and must be eliminated by correct equipment adjustment in order that stable operation of the station can be assured.

A sample work sheet showing all construction lines for a typical graphical solution is shown in Figure 5 and a portion of a completed sample course alignment data sheet as used by the CAA is shown in Figure 6.

#### Solution for Determining Per Cent Modulation

The graphical method is employed further to cover the adjustment of the per cent modulation for the range signals. For stations equipped for simultaneous voice broadcasts, the maximum per cent modulation permitted for the range signals is 30%, the other 70% being allotted to the voice modulation. The constant output feature of the voice amplifiers limits the maximum voice modulation

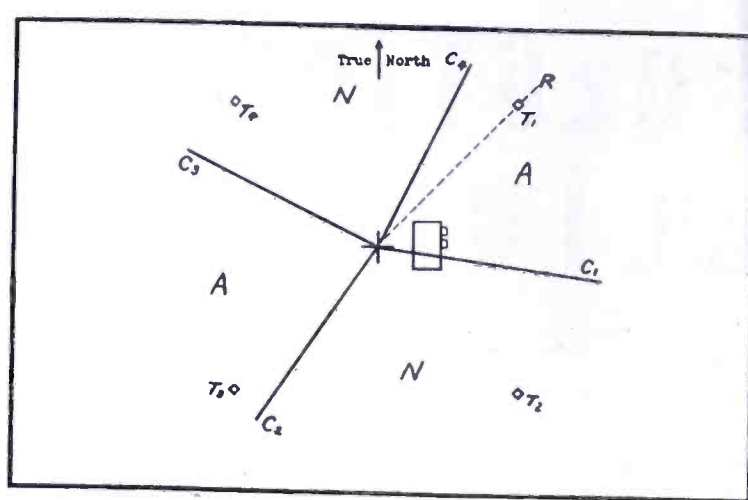

Figure 6 (above)

Portion of completed sample course alignment sheet as used by CAA. This appears on a data sheet with the following information: Diagonal tower distance, 600'; tower bearing, 225° true, toward center; magnetic declination 5° W from true North; required courses, 35, 116, 207, and 278, true and toward station; carrier frequency, 300 kc. Equipment settings (by graphical solution) . . . goniometer, 24°; current ratio, I (A)/I (N) = .78; L<sub>1</sub> = 4.1°; L<sub>2</sub> = -3.4°; L<sub>3</sub> = 4.1°; L<sub>4</sub> = 3.4°. L is the ± electrical line length from normal or optimum length. Ratio of tower currents for 30% modulation on strongest course (measurement made with goniometer set at zero) is  $\frac{I_{T1}}{I_{TC}} = .30$ . This computation is based on the understanding that towers T<sub>1</sub> and T<sub>3</sub> transmit an "A" signal when the goniometer is set at zero. If it should be found that towers T<sub>1</sub> and T<sub>3</sub> transmit an "N" signal when the goniometer is set at zero, or if it should become necessary to produce that condition by a reversal of connections in the goniometer primary, then 90° is added to the given goniometer setting and the goniometer is set at 90° instead of 0°, when adjusting current in tower T<sub>1</sub> for 30% modulation.

to 70% so that the range signals may employ the entire remaining 30% without causing over-modulation. Since the range signals are produced by the beating of the carrier, emitted from the center tower, and the single sideband radiated from the corner towers, the per cent modulation of the range signal is equal to the ratio of the sideband field strength to carrier field strength and the ratio varies with direction from the station because of the difference in field patterns of the two components.

Since the on-course signals are of primary importance, the per cent modulation is set so that maximum allowable modulation exists on the on-courses. All courses will have the same percentage of modulation if course bending is not present; but if bending exists, the per cent modulation of the on-courses' signals will vary. Thus, under conditions of bend, only the modulation on one course can be set at 30% and the others will have a smaller value.

To adjust the relative output of the carrier and sidebands so that 30% modulation exists on the strongest course or courses, the power output of the carrier channel is first adjusted to the level designated for the desired coverage of the station. Then the sideband power is adjusted by setting the r-f current in the sideband tower T<sub>3</sub>, when the goniometer is set on zero, in accordance with the ratio of currents obtained from chart 4, after the values of L<sub>G</sub> and angle A are determined by

(Continued on page 81)

# POLICE RADIO EQUIPMENT

**AVAILABLE NOW!**

WPB has permitted us to return to our pre-war products to a limited extent. Police Radio Communication Equipment can be supplied on priority ratings.

Our Sales Department is ready to assist you in getting priority ratings. Write for Police Radio Equipment Catalog and further particulars.

*by*  
**Doolittle**

**FM**  
OR  
**AM**

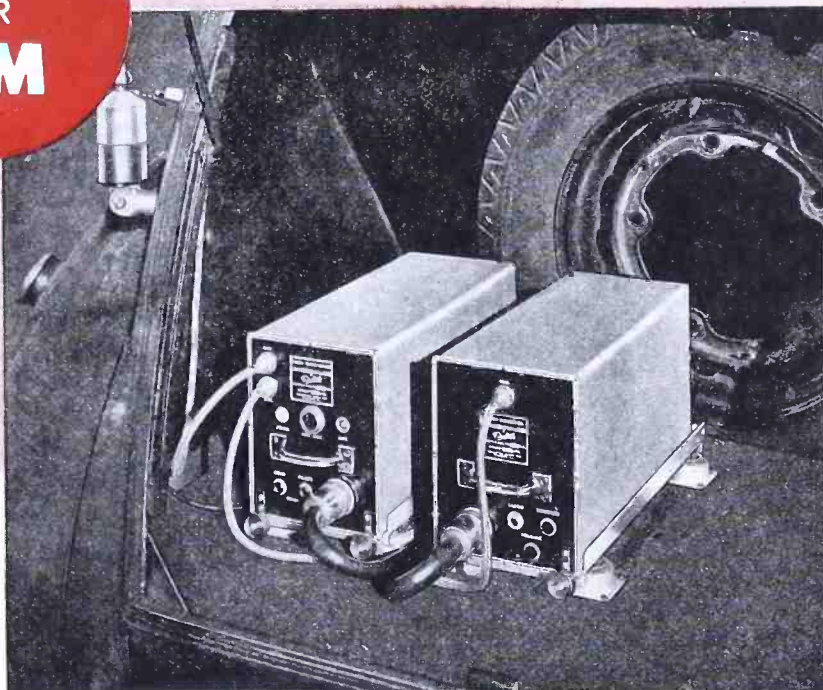

*Doolittle* **RADIO, INC.**  
7421 South Loomis Boulevard, Chicago 36, Illinois

BUILDERS OF PRECISION RADIO COMMUNICATIONS EQUIPMENT

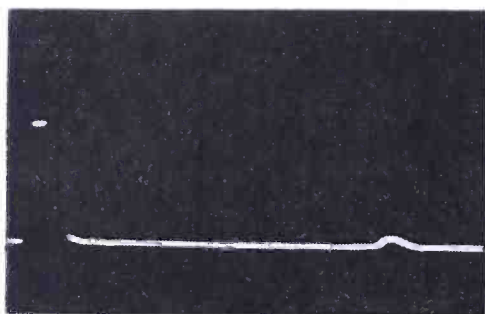

A

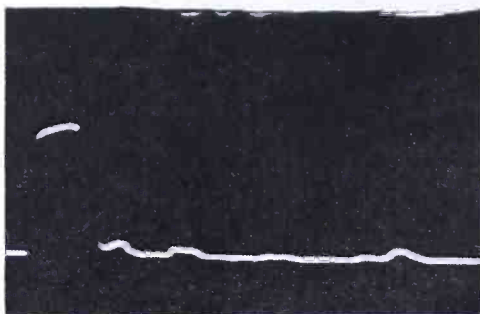

B

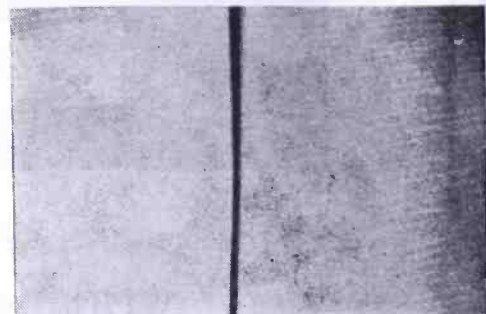

C

Photographs of oscilloscope responses (antenna pointed at transmitter) at 400 and 51.25 mc, and bar and test patterns at 51.25 mc included in multipath propagation test report of E. W. Engstrom. In *A* and *B* appear the responses at 400 mc for relative receiver gains of 1 and 10. A study of these views reveal that the multipath responses are relatively small compared to the main pulse. In *C* appears a photograph of one set of pulses in the middle of the television raster (51.25 mc). Horizontal deflection was synchronized on the other double frequency horizontal pulses. In *F* appears a photograph of the test pattern with the pulse modulation removed from the transmitter. A reasonable freedom from multipath effects is apparent. In *D* and *E* appear oscilloscope responses at 51.25 mc, for relative receiver gains of 1 and 10, respectively. Receiving antenna used for these tests was located at same spot as 400-mc antenna. Receiving antenna pointed down Fifth Avenue toward Empire State Building in New York City. It can be seen that there are no reflections whose amplitudes are greater than the order of 1% or 2% of the main pulse. The report states that an examination of the original negative from which *A* was made showed a response close to the main response, whose amplitude was 20% to 30% that of the main response. In view of the limitations in reproduction, this response does not show. The pulse nearest the right hand side of *A* and *B* are time marker pulses on the receiver oscilloscope and not responses to transmitted pulses.

D

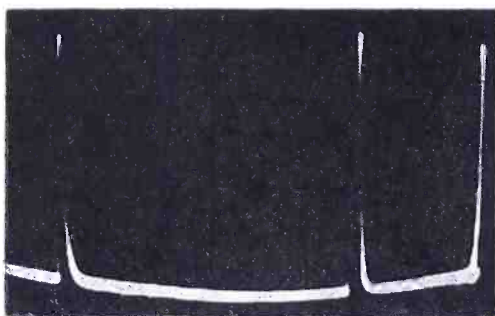

E

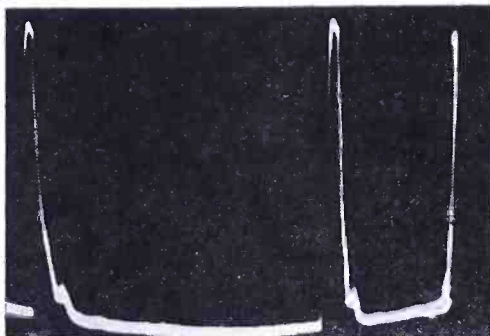

F

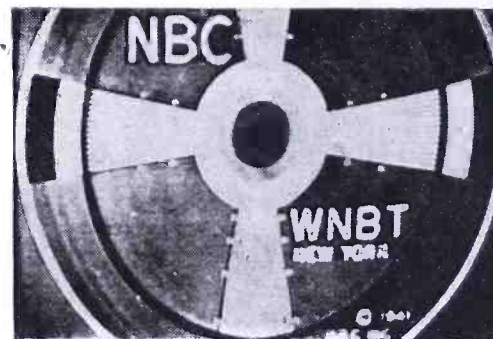

## A REPORT ON THE FCC ALLOCATION HEARINGS ON TELEVISION

Highlights Of Statements Presented By

E. W. Engstrom, Dr. P. C. Goldmark and G. L. Beers

TELEVISION received quite a thorough analysis at the recent FCC allocation hearings in Washington. Statements offered by a score of technical and administrative experts from government and industry, covered a wide variety of subjects including lineage, bandwidths, antennas, multipaths, color, u-h-f/v-h-f techniques, etc.

Discussing the multipath problem, E. W. Engstrom, research director of RCA Laboratories, disclosed that a series of 400-mc multipath propagation tests had been made by the technical staffs of RCA Laboratories and NBC. The report indicated that for regions having large buildings and where difficulties have been had in the past from multipath transmission paths at 51.25 megacycles and at other television channels below

by LEWIS WINNER

Editor

90 mc, the same difficulty was evidenced at 400 mc. The report stated that it appeared to be more difficult to find an antenna location at 400 mc reasonably free of multipath transmission effects, than at 51.25 mc. However, in residential areas at some distance from the transmitter where the 51.25-mc multipath transmission effects were not serious, a similar freedom from the trouble prevailed at 400 mc, according to the report.

A rather interesting procedure was used to conduct these tests. Short pulses of 400-mc signal were transmitted and observed at several receiver locations. Where multipaths effects were noticed, the time delay factor proved important.

That is if two paths prevailed, one a direct path and one a path resulting from a reflection from an object such as a building off to one side, the first pulse would be the one arriving over the direct path and the second would be the one arriving over the path provided by the reflection. This second pulse would arrive a bit later than the first, depending of course on how much longer the reflection path was than a direct path. According to the report, if the reflection path were one mile longer than the direct path, the second pulse would arrive at the receiver approximately 5 microseconds after the first pulse.

Analyzing the transmitter and receiving equipment used to make these tests, the report stated:

"The transmitter which was available

# 2

# POPULAR RCA INSTRUMENTS

## for high-precision measurement work

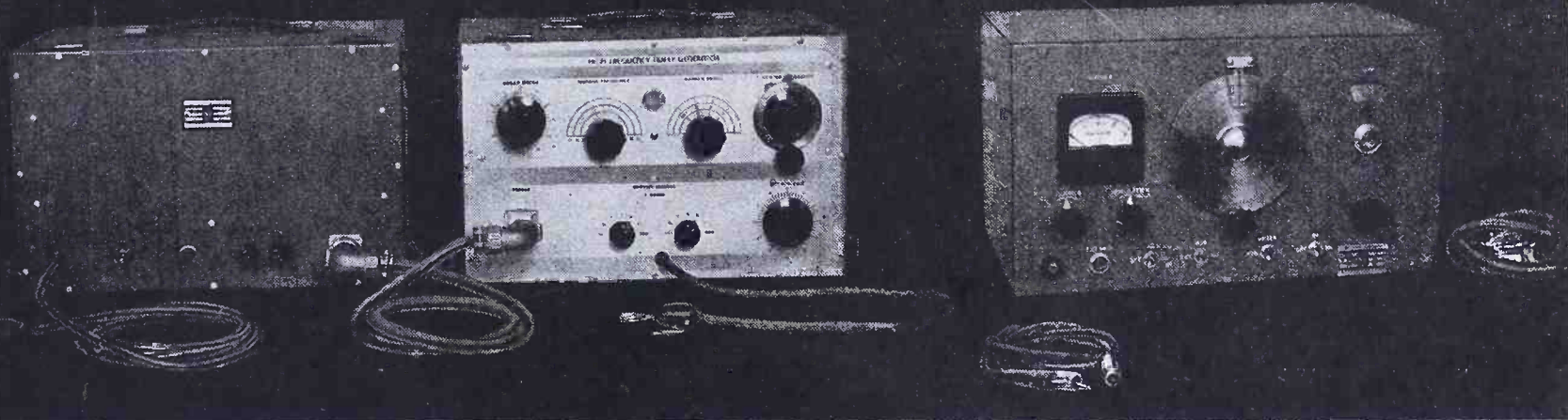

### RCA High-Frequency Wide-Band Sweep Generator

*Type 709 B*

### RCA Ultra-High Frequency Signal Generator

*Type 710 A*

**T**HE big job is done—valuable development, production and field test experience are combined in two quality products—the 709 B Sweep Generator and the 710 A Signal Generator. Here are two instruments every Television, FM and H.F. Laboratory can rely on for postwar design applications.

The 709 B Sweep Generator covers the frequency band of 5 to 65 megacycles (center frequency). It is ideal for high frequency I. F. curve response study. Its calibration marker permits constant checking of band width characteristics.

The 710 A Signal Generator, with a frequency range of 370 to 560 megacycles, is widely used for checking high frequency devices. This instrument provides

smooth and complete attenuation throughout its range, plus precision frequency control.

Planning your postwar activity means planning your laboratory facilities as well. Now is the time to investigate the characteristics of these reliable RCA instruments.

*RCA bulletins containing complete descriptions and specifications of the 709 B Sweep Generator and the 710 A Signal Generator will be sent promptly on request.*

*Please note that deliveries of these instruments are subject to regulations of WPB General Scheduling Order M-293.*



## RADIO CORPORATION OF AMERICA

RCA VICTOR DIVISION • CAMDEN, N. J.

*In Canada:*

RCA VICTOR COMPANY LTD., MONTREAL

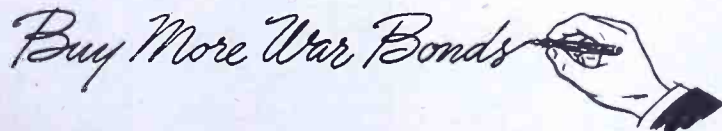

for making these tests produced pulses of approximately two microseconds duration at 400-mc. The peak power in the r-f pulses was approximately 20 kw. The pulse repetition rate was approximately 1,000 cycles, and the receiver used for the tests had a bandwidth of approximately one megacycle. The received impulses were presented for observation on a cathode-ray type oscilloscope having a sweep rate of 1,000 cycles, with an expanded scale of approximately 120 microseconds for 9" of deflection.

"The pulse rate at the transmitter and the sweep rate at the receiver were both controlled by crystal oscillators. No effort was made to synchronize the two since they were found to be quite stable and it was possible to pull the frequency of the crystal oscillators so that the system was substantially synchronized for periods long enough to make observations.

"For most of the tests a dipole antenna mounted a half wavelength in front of a rectangular reflecting plate, 20" by 24", was used at the transmitter. The receiving antenna was identical with this transmitting antenna.

"All of the tests were made with the transmitter on the 85th floor of the Empire State Building in New York City, and horizontal polarization was used. The transmitting antenna was mounted in a window facing north. Tests were made with the receiver at several locations, varying from Radio City, three-quarters of a mile north of Empire State Building, to some detached private residences 15 miles north of the Empire

State Building. At each location photographic records of the received oscilloscope traces were made with different antenna orientations. For each antenna position the receiver was adjusted so that the largest received pulse was just below saturation of the oscilloscope, and a photograph of the trace was made. The gain control was then increased by a known ratio, usually 10 to 1, driving the largest echo into saturation on the oscilloscope and bringing small echos which might be present up so they became visible. In this manner, a record was obtained which showed multipath responses whose amplitude was greater than 1 per cent that of the main response. Tests were made in this manner with the receiving antenna pointed toward the transmitter so as to receive the maximum signal over a direct path and then repeated with the antenna turned 45°, 90°, and 180° from its original direction. In all, some 80 different sets of data were taken in this manner.

"Similar tests on pulse transmissions from the regular WNBT television transmitter were made. For the 51.25-mc tests an RCA TRK120 television receiver was used. For presentation of the output pulses from the receiver a 9" oscilloscope was used. In order to duplicate as nearly as possible the conditions of the 400-mc tests at 51.25 mc, a dipole antenna was installed in a north window of the 85th floor of the Empire State Building and connected to the WNBT transmitter. Modulation on the transmitter consisted of double-frequency horizontal synchronizing pulses originating in a television synchronizing generator and shortened by a transmission line arrangement. These pulses drove the transmitter to peak power. The modulator was biased so that the carrier was a minimum between pulses. These pulses, as presented on the oscilloscope at the receiver, were considerably narrower than the pulses which had been received at 400 mc. This was due mostly to the fact that the bandwidth of the television receiver was 4 mc, while the 400-mc receiver had a bandwidth of only 1 megacycle."

Six types of television interference were listed by Mr. Engstrom. In order of their importance they were: (1) shadow; (2) multipath; (3) radio noise; (4) sporadic E reflections; (5) bursts; and (6) F-2 layer reflections. In view of all these factors, said Mr. Engstrom, television should start at, as near to 45 mc, as possible.

#### Dr. Goldmark's Statement . . . U-H-F in Television

THE position of u-h-f in television was discussed by Dr. Peter C. Goldmark, chief television engineer of CBS, at the hearings. According to Dr. Goldmark, television in the ultrahigh frequencies will give a more satisfactory and permanent service than it can in the frequencies presently assigned to it.

The use of u-h-f would permit widening the present 4-mc video band to 10 mc, which would require a maximum channel of 16 mc, he said. This would be utilized for transmission in black-and-white at 735 lines per picture or in color with 525 lines. According to Dr. Goldmark, the 10-mc bandwidth proposal is based on data and calculations showing that the average 16-mm professional film will

produce a picture with a texture which is equivalent to about 680 lines or 750 lines if we allow for blanking. The proposed 735-line black-and-white system which actually give 660 lines per picture, he said, is thus almost identical in definition to the average professional 16-mm film.

Discussing the discrepancy in pure geometrical definition that exists between the 735-line monochrome and the 525-line color pictures, he said that the added information resulting from color more than offsets that difference.

Dr. Goldmark pointed out that two u-h-f television transmitters to operate between 460 and 476 mc have been ordered from Federal Telephone and Radio Corporation and General Electric Company. He said that these transmitters will be capable of handling modulation in excess of 10 mc. Dr. Goldmark said that the Federal transmitter would provide combined audio and video transmission on the same carrier. No further details were offered.

Analyzing the advantages which the u-h-f region appears to offer to receiver design, Dr. Goldmark said that u-h-f carrier frequencies are high compared to the width of the transmission band, making it possible to have a large number of wide channels within a relatively narrow spectrum.

He said: "In the prefer television allocation structure the useful spectrum extended from 50 mc to 294 mc, thus covering something like 2½ octaves. The highest television carrier frequency in the band is nearly six times the lowest car-

(Continued on page 78)

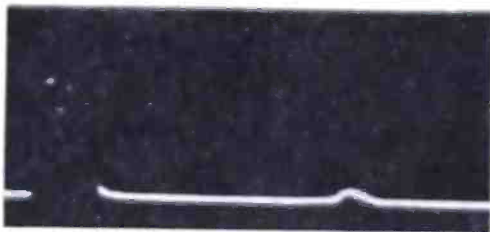

Oscilloscope response at 400-mc, receiver gain of 1, antenna pointed 90° from transmitter.

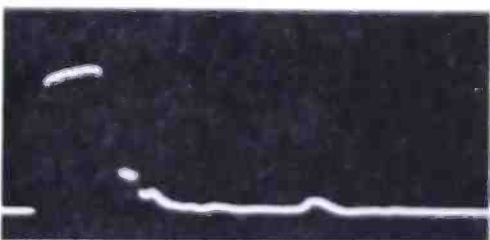

(Above) Oscilloscope response at 400 mc, receiver gain of 10, antenna pointed 90° from transmitter. An echo practically as large as the main response, delayed approximately 3 microseconds, was noticed in these tests. (Below) Photograph of pulse pattern at 51.25 mc.

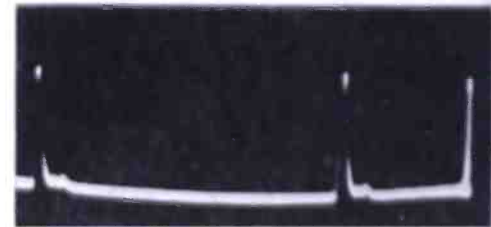
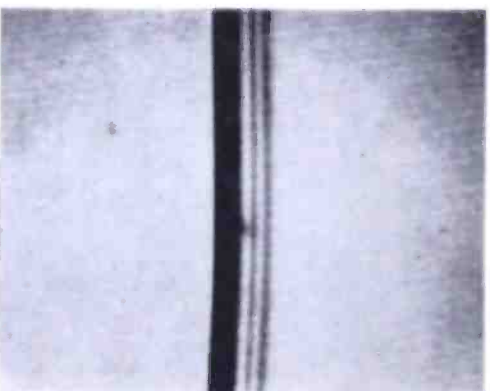

Oscilloscope response at 51.25 mc, receiver gain of 1, antenna pointed 90° from transmitter. Here and in response shown below, two multipath responses in the order of 8% of the amplitude of the main response as well as small echos, with amplitudes of 1% to 2% are shown.

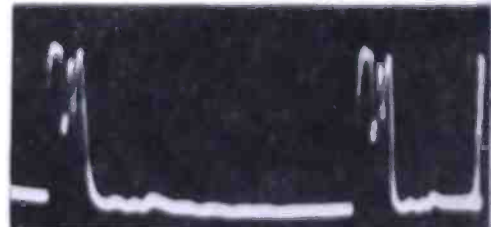

(Above) Oscilloscope response at 51.25 mc, receiver gain of 10, antenna pointed 90° from transmitter. (Below) A photograph of test pattern at 51.25 mc, with antenna pointed 90° transmitter.



# Some

# INTERESTING FACTS ABOUT HYTRON

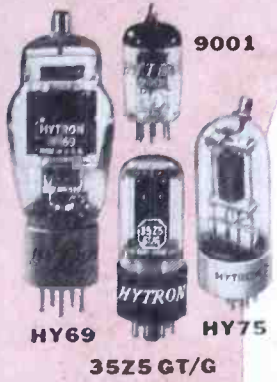

- ★ Hytron is the oldest manufacturer in the United States specializing on radio receiving tubes. The first Hytron tube was made by hand in 1921.
- ★ The now standard BANTAM GT receiving tube is a Hytron origination. Hytron designed and developed over 70 of the popular GT types. These small glass receiving tubes contributed to the development of the miniature table radio and to large scale production of radio and radar equipment for the Services.
- ★ The tiny BANTAM JR. tubes originated by Hytron were the first sub-miniatures. They made possible hearing aids and pocket radio sets. Similar Hytron tubes serve in wartime electronic devices.
- ★ Hytron has pioneered transmitting and special purpose tubes for the radio amateur and for police radio. Its very-high-frequency tubes and its instant-heating r.f. beam tetrodes for mobile communications, have also become extremely popular with the Services.
- ★ Hytron combines long experience in high-speed receiving tube techniques with the know-how of special purpose tube engineering. The result is economical mass production of special tubes.
- ★ First of the receiving tube manufacturers to convert 100% to war production, Hytron will be just as alert in serving the post-war market.

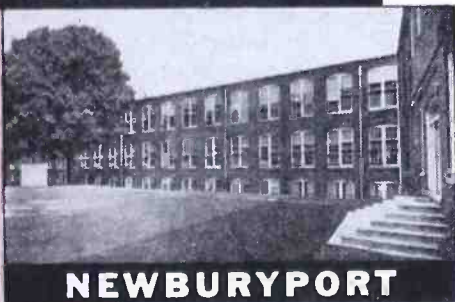
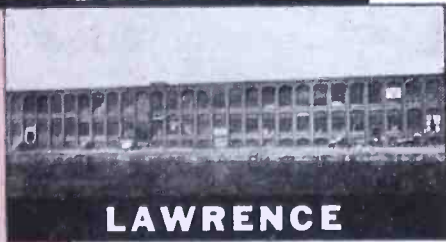

CONSULT HYTRON regarding your needs for these tubes: receiving, ballast, hearing aid, very-high-frequency triodes and pentodes, miniatures, medium and low-power transmitting triodes, r.f. beam tetrodes (particularly instant-heating), r.f. pentodes, gaseous voltage regulators, and rectifiers.

OLDEST EXCLUSIVE MANUFACTURER OF RADIO RECEIVING TUBES

**HYTRON**  
CORPORATION  
ELECTRONIC AND RADIO TUBES  
SALEM AND NEWBURYPORT, MASS.



**BUY ANOTHER WAR BOND**

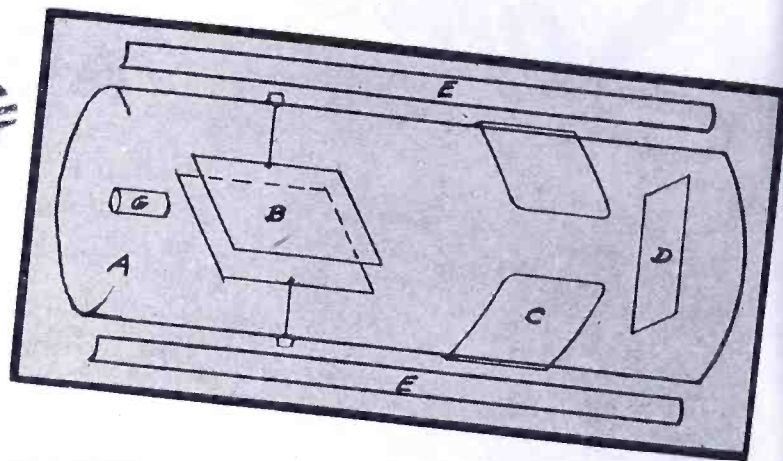
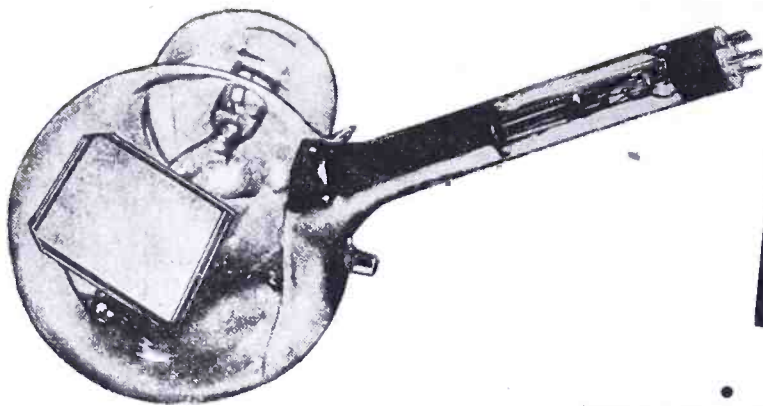

Figures 1 (left) and 2 (right)  
 Figure 1, the iconoscope, one of the first camera tubes to be developed. Figure 2, constructional details for orthicon: A, glass envelope; B, static deflection plates; C, magnetic deflection coils; D, translucent mosaic screen; E, field coils, and G, electron gun.

## C-R TUBES...SPECIAL DESIGNS

by **J. R. BEERS**

Development Engineer  
 North American Philips Co., Inc.

**T**HERE are several types of video type tubes that are based on the application of cathode rays and cathode-ray guns. Among these are iconoscope, orthicon, and image dissector which come under the classification of camera tubes.

In the iconoscope the gun is basically the same as that used to activate the fluorescent screen of the tubes analyzed in previous papers. In this application, however, the cathode ray is used as a means for discharging electrical energy. This energy is generated on a light sensitive mosaic upon which a picture (to be transmitted) is focused by means of a conventional lens system. Figure 1 shows one of the first tubes used for this purpose.

The target plate consists of an extremely thin and uniform mica sheet, backed by a metal plate. The surface of the mica facing the gun is sensitized by deposition of caesium metal upon a base of silver oxide. This is applied so as to form tiny photoelectric cells each insulated from the other. The mosaic surface may be charged by visible light rays, as in the television application, or it may be designed to respond to normally invisible rays, such as infrared.

Information gathered by the sen-

sitized plate is translated into electrical impulses, when scanned by the electron beam from the c-r gun. Scanning, in this case, is accomplished by magnetic fields.

In this type of tube, the electron beam used for the discharge is necessarily of high speed, due to gun design and the small spot-size required. Because of this, more secondary electrons are released at the mosaic than can be collected. These excess secondaries fall back on the mosaic, causing unwanted localized charging.

The orthicon tube, using slow speed electrons for scanning, was subsequently developed to overcome this condition. Construction of the tube is shown in Figure 2. It employs both electrostatic and magnetic deflection of the electron beam and utilizes the same type of mosaic screen.

The image dissector tube serves all of the similar purposes as previously mentioned tubes. However, it does not possess the same memory features. Signals produced are much weaker, so electron multipliers are frequently built in as an integral part of the tube. An early form of the tube used a mosaic film that was translucent. Here, the screen acts as a cold cathode from which electrons are emitted in direct proportion to the light intensity of the image focused upon it. These electrons are attracted to the anode at the opposite end of the tube. A small aperture in its center permits

electrons to pass through the anode to a target. This produces a signal corresponding to the emission resulting from light focused on the cathode at that point. By means of magnetic fields, the entire electron image is made to pass before the aperture in a fixed scanning pattern. Thus, electrons from every segment of the cathode are systematically collected by the target. In this manner the cathode image is dissected, and the picture information transmitted as electrical fluctuations. In newer designs the cathode consists of an opaque surface which is excited through a window at opposite ends of the tube.

In present-day television these tubes are the basis for picture transmission just as the fluorescent screen type are a basis for picture reception. However, at the present stage of television development there appears to be a greater field for possible changes and improvements in picture tubes than in camera tubes.

Foremost among reception improvements is the subject of projection. In Figure 3 is shown a projection type receiver. This receiver uses a projection type c-r tube having a 4" face diameter which projects a picture 16"x20" on a translucent screen. A top voltage of 25,000 is used in this receiver. Method of projection is shown in Figure 4.

Although such a receiver appears to answer the requirement for larger



# LOOK AT THIS EXCLUSIVE HARWOOD FEATURE . . . .

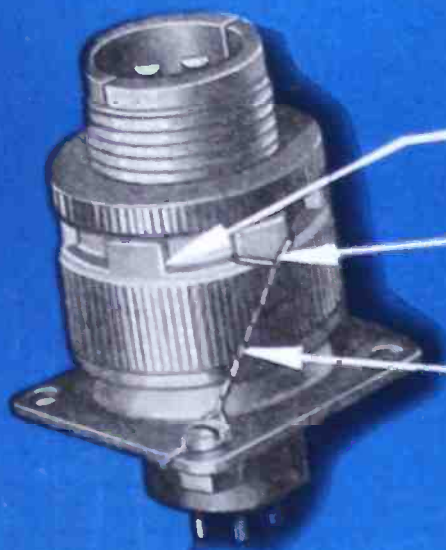

Castellated coupling nut, adapted to spanner or strap wrench, has many important advantages.

Safety wire is instantly attachable to any one of six positions, or lugs, on the coupling nut — without drilling a hole. Rounded edges of lugs prevent crimping of wire.

Release of wire presents no difficulty. Wire pulls clean; no drilling out.

FIELD CHECKS for a "short" or an "open" are quick and easy jobs if the connectors are Harwood with castellated coupling nuts. Simply cut the safety wire, untwist and pull out. It comes away clean, as it has not been crimped on the sharp edges of a tight-fitting drilled hole.

Reassembly is as easy. No holes to drill. Just loop the wire over a lug on the castellated coup-

ling nut, which will be in correct locking position when the nut is tightened, then secure. This Harwood feature is an advantage in shop assembly, too. Write for details today.

## THE HARWOOD CO.

Division of Los Angeles Corp

540 N. LA BREA AVE., LOS ANGELES 36, CALIF.

AN STANDARDS FROM 10S TO 44S IN  
QUANTITY DELIVERIES ON SCHEDULE



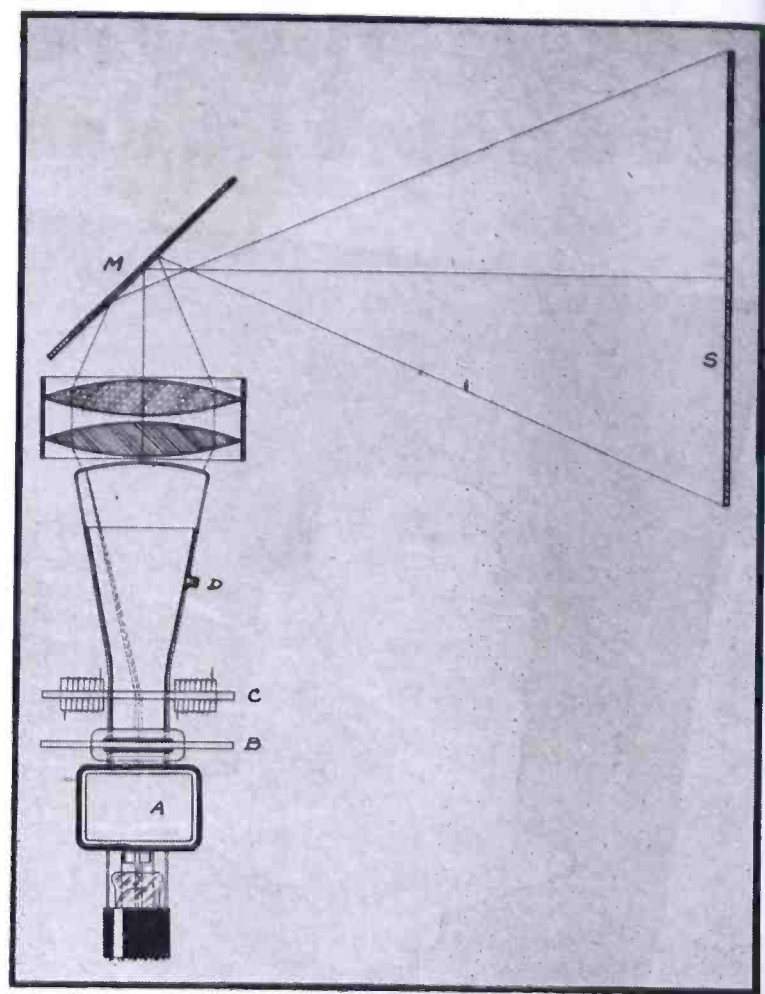
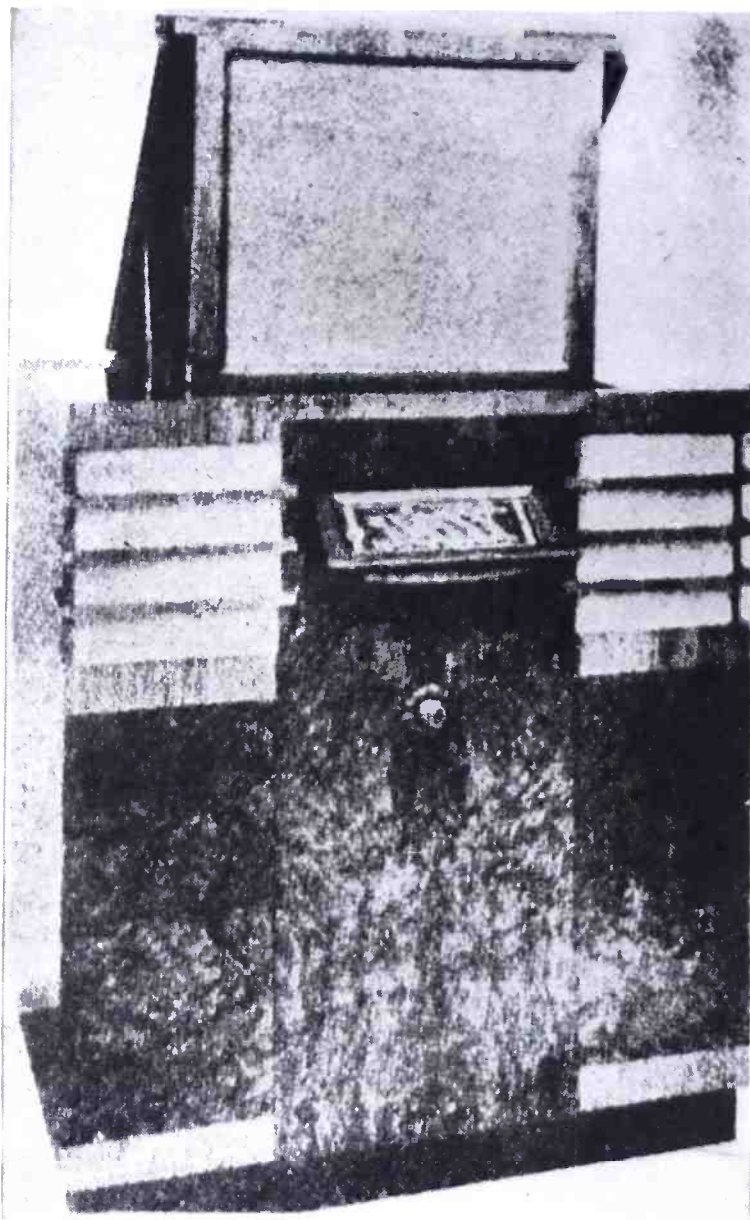

Figures 3 (left) and 4 (above)  
 Figure 3, Philips type projection receiver using trans-lux screen; picture size is 16" x 20". Figure 4, projection method used in this receiver: A, focusing coil; B, vertical deflection coil; C, horizontal deflection coil; D, high potential anode; M, mirror; and S, translucent screen.

pictures there is still a considerable problem in light level and tube life as compared to direct-viewing tubes. Many experiments have been made with dark-trace screens and various types of electronic light shutters or valves. However, thus far the fluorescent type screen appears to be the most practical. Since this material has definite limitations as a light source

Figures 5 (below) and 6 (below, right)  
 Figure 5, one arrangement of Schmidt optical system for television projection: A, apertures; B, metallic surface of mirror; C, correction lens; M, concave mirror; M<sub>1</sub>, plane mirror-reflecting surface on side toward tube; S, screen; and T, projection c-r tube. Figure 6, the new Baird electronic color television tubes.

when operated at outputs consistent with satisfactory life, it becomes necessary to increase efficiency of projection system to highest possible degree.

An adaptation of Schmidt optics for projection appears to have initial efficiencies considerably in excess of the conventional lens systems. Figure 5 shows one arrangement of this system. A relative aperture of F/6 as compared to F/1.5 in the conventional systems as well as fewer reflecting surfaces favor the Schmidt system. Although at first glance it would appear that final decision might be made in favor of this system, experience has shown that

there are other critical factors to be considered. Since the mirror surfaces of the reflectors are metallic and exposed to atmospheric action they are subject to a certain degree of corrosion. The problem of dust deposits on the mirror surfaces also has to be considered. Either of the above difficulties may reduce the efficiency of the system to below that of a conventional system whose light losses have been reduced by non-reflective treatment of the lens surfaces.

Another factor in determining final light level is the efficiency of projection  
 (Continued on page 80)

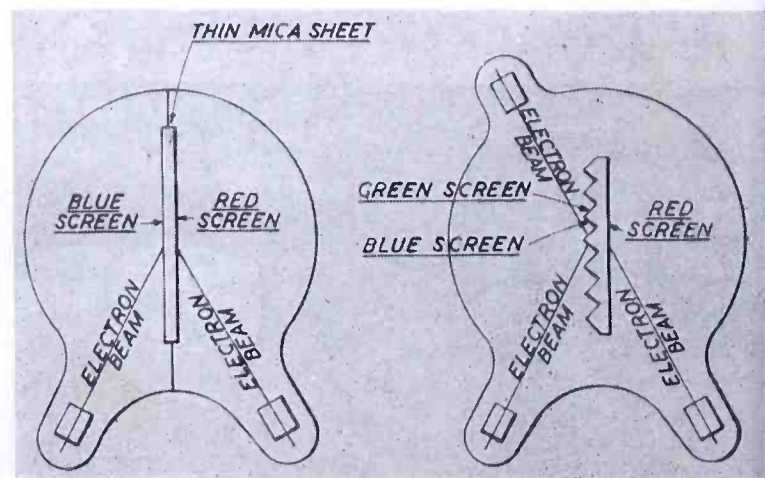
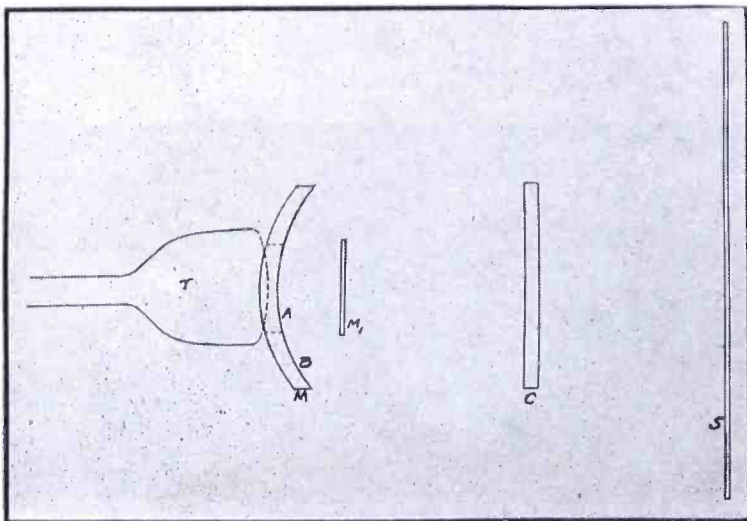

**COLONEL JOHN CASEY, Manager,**  
**Chicago Municipal Airport . . .**

*Colonel Casey said, "The growing complexities of airport traffic make it ever more important that private planes and regular operating passenger aircraft be equipped with up-to-date, reliable two-way radio, if high standards of safety are to be maintained. One important factor is . . ."*



## **"A FOOLPROOF POWER SUPPLY FOR AIRCRAFT RADIO OPERATION"**

Colonel Casey, Electronic Laboratories has long been aware of the need for reliable power supplies especially adapted for aircraft use. One of E-L's exclusive developments along this line involves vibrators operating in parallel which assures a reserve power source for extra protection. These Vibrator Power Supplies—both light and heavy duty—are specially designed for complete reliability at very high altitudes.

The life of E-L Vibrator Power Supplies is far beyond the customary overhaul requirement. With these units maintenance time is cut to a minimum—only a small fraction of the time previously required.

Other E-L developments for the aircraft field include units for flashing wing lights and for instrument panel illumination. This equipment has wide application for the light plane field as well as for large aircraft.

The economy and versatility of Vibrator Power Supplies are also available to the marine field—where units have been designed to provide fluorescent lighting, radio-telephone operation and electrical appliance use—as well as many other fields where it is necessary to convert current to specific voltage and type requirements . . . Let E-L engineers consult with you on your power supply problem.

### **STANDARD POWER SUPPLY MODEL SC-1096**

Model SC-1096 is a typical E-L Vibrator Power Supply which meets the requirements of aircraft radio use. This unit was designed for the Canadian Signal Corps to operate radio transmitters. Input voltage: 12 volts DC, or 110-117 volts AC at 50-60 cycles. Output voltage: 2000 volts at 125 ma., 400 volts at 25 ma., 250 volts at 10 ma., 250 volts at 5 ma., 10 volts at 5 amps., 12 volts at 1 amp. Output power: 480 watts. Dimensions: 17" x 12 $\frac{3}{4}$ " x 7 $\frac{3}{4}$ ".

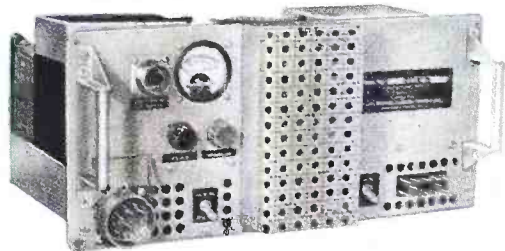

# *Electronic*

**LABORATORIES INC.**  
INDIANAPOLIS

VIBRATOR POWER SUPPLIES FOR LIGHTING, COMMUNICATIONS, AND ELECTRIC MOTOR OPERATION • ELECTRIC, ELECTRONIC AND OTHER EQUIPMENT

# Franklin's 39

## RADIO SOCKET

*The favorite yesterday, the favorite for tomorrow*

THE MANY MILLIONS INSTALLED IN 1941 IS

*Positive Testimony to its*  
**POSTWAR VALUE**

The story of Franklin's series 39 Radio Socket, with patented "U" shaped bow spring action contacts, is most remarkable ... developed and patented early in 1938 it received immediate acceptance and approval by practically all the radio set manufacturers and became standard equipment with most.

Series 39 sockets should be riveted to the chassis to become a permanent part of the set ... no replacement will be necessary as the socket will outlive the set.

Series 39 sockets were the favorite yesterday and will be the favorite tomorrow for standard broadcast receivers.

For the details of the 39, Diheptal, Miniature, Lock-in, Battery and Sockets for other applications, moulded or ceramic...and a complete line of Radio Components...write for the New Franklin Catalog with which is included a complete Buyers Guide for the Electronic Industries.



# A.W. FRANKLIN MANUFACTURING CORP.

SOCKETS • TERMINAL STRIPS • PLUGS • SWITCHES • PLASTIC FABRICATION • METAL STAMPINGS • ASSEMBLIES

175 VARICK ST., NEW YORK 14, N. Y.

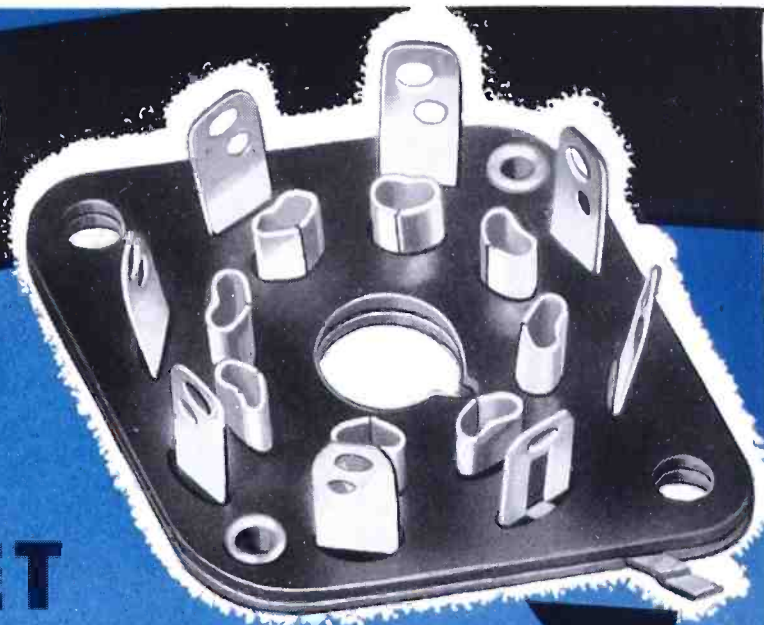

This series 39 socket has a 39G Contact with a soldering tab which eliminates wiring to ground.

Illustrating the "U" shaped bow spring action contacts...39H and 39G...used in Franklin's series 39 Sockets.

Bow spring action maintains resiliency even after installation of oversize pins

Direction of metal grain prevents breaking of soldering tail and permits rough handling in production



"U" shaped contact provides separate soldering tail which prevents solder from flowing into contact body

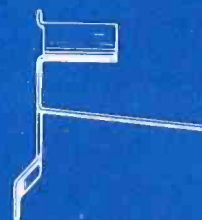

The 39G contact has a soldering tab to eliminate wiring to ground ... can be inserted in any position where grounding is desired.

# QUARTER-WAVELENGTH INSULATORS

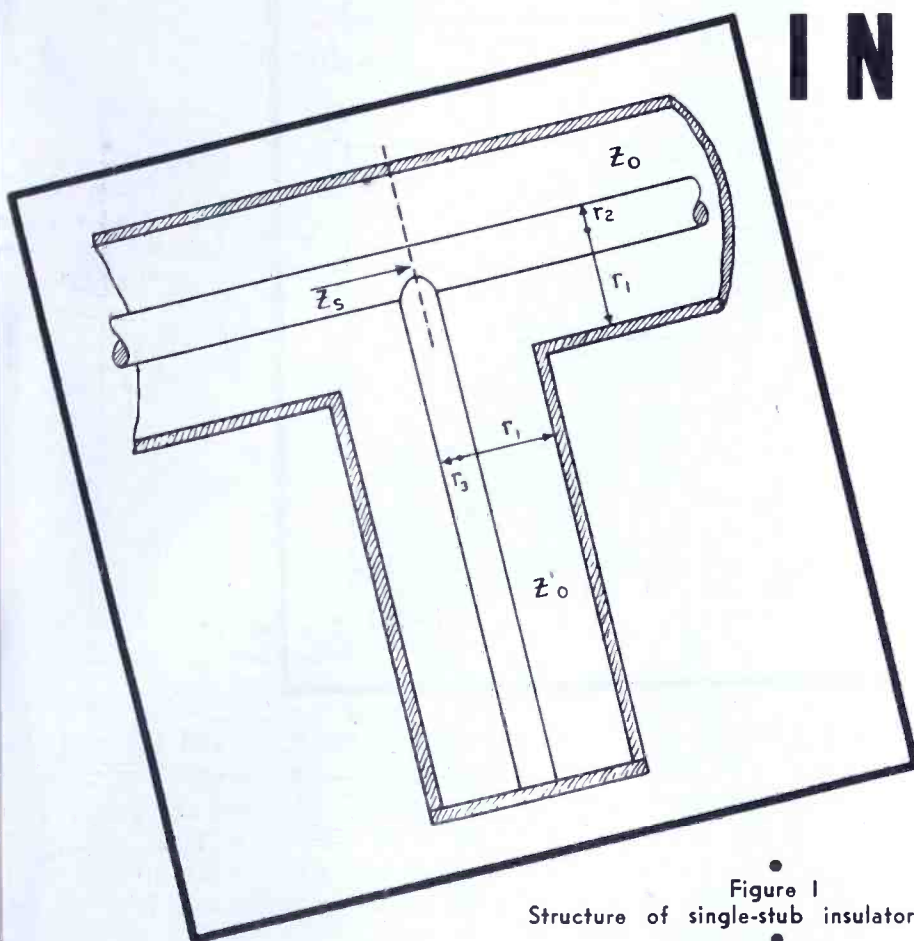

Figure 1  
Structure of single-stub insulator support.

by LAWRENCE A. WARE  
Associate Professor  
Electrical Engineering Dept.  
State University of Iowa

$$= \frac{Z_0 \tan b}{\sqrt{\tan^2 b + n^2}} \tan^{-1}(n/\tan b) \quad (1)$$

where  $n = \frac{Z_0}{Z'_0}$  . (2)

It is convenient in the following material to work with the ratio of  $Z_s/Z_0$ .

$$\frac{Z_s}{Z_0} = \frac{\tan b}{\sqrt{\tan^2 b + n^2}} \tan^{-1}(n/\tan b) \quad (3)$$

$$= \frac{1}{\sqrt{1 + \left(\frac{n}{\tan b}\right)^2}} \tan^{-1}(n/\tan b) \quad (4)$$

$$= A / \theta^\circ \quad (4')$$

The ratio given by equation 4 will give an indication of the amount of mismatch caused by the stub and from it the resultant loss can be determined as  $f$  is varied away from  $f_0$ . It is readily seen from equation 4 that as  $n$  is decreased,  $A$  in equation 4' approaches unity and  $\theta$  approaches zero for fixed values of frequency or of  $b$ . It is clear then, in this simple case, that if an improvement in *broadbanding* is to be obtained,  $n$  must be made as small as practicable. This decrease in  $n$  however involves an increase in  $Z'_0$  and thus a decrease in the radius  $r_3$ . There may exist, in practical cases, a lower limit to  $r_3$  owing to the possible breakdown of the air around the inner conductor if the transmitted power is very high. Curves for  $A$  and  $\theta$  are plotted in Figure 2 for three values of  $n$ . In Figure 3 are plotted two curves of attenuation caused by such a stub for values of  $n = 1.0$  and  $0.8$ . It is to be noted for future reference that at  $b = 80^\circ$  and  $100^\circ$  and for  $n = 0.8$ , the loss of about 0.02 db, which is an im-

IN the use of coaxial lines at ultra-high frequencies it is often convenient to make use of quarter-wave short-circuited stubs to support the inner conductor. As long as only a single frequency is to be transmitted this method offers no particular difficulty, as the stub can be adjusted to be one-quarter wavelength long at the given frequency, to which it will offer infinite impedance. However, if a band of frequencies is to be transmitted there will be reflection loss at all frequencies except the one for which the stub has been designed. As an introduction to this problem let us consider the simple single-stub support represented in Figure 1. Later we will analyze the problem of broadening the band, over which low attenuation will occur.

**(A)—The Single Stub Support**

In Figure 1, we have the main transmission line represented as having a characteristic impedance  $Z_0$  given by the usual equation,  $Z_0 = 138 \log(r_1/r_2)$ . Suppose we design the stub for a frequency  $f_0$  which will be called the midfrequency. The stub will differ in general from the line itself by having a different characteristic impedance,  $Z'_0$ , brought about by adjusting the

**The short-circuited quarter-wavelength line used as a support for the inner conductor of high-frequency coaxial lines is considered in this paper. Three cases are treated specifically: a—The single stub support; b and c—Two special cases of the double stub support. It is shown that, by making appropriate adjustments of the characteristic impedances in these elements, broadbanding is improved, i.e., a broader band of frequencies may be transmitted with less loss due to mismatching. As an illustration a design of a double-stub support to operate at 750 megacycles is presented.**

radius  $r_3$  of the inner conductor. The length of the stub will be such that at  $f_0$  it is one quarter-wavelength long and its angular length will be designated by  $b$  given by  $b = (f/f_0)90^\circ$ , where  $f$  is the frequency of operation and will not be considered to differ from the midfrequency by more than about 10%. Neglecting the resistance of the conductors, the input impedance to the stub is

$$Z = j Z'_0 \tan b$$

and  $Z_s$  can easily be calculated as follows:

$$Z_s = \frac{Z Z_0}{Z + Z_0} = \frac{j Z'_0 Z_0 \tan b}{Z_0 + j Z'_0 \tan b}$$

the degree

to which your communications problems are solved may determine the degree of your postwar business success.

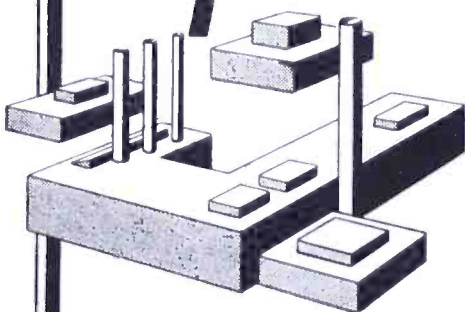

The First of a New Series of Bulletins Introducing FREQUENCY CONTROL UNITS . . . Now Ready. Also an Attractive Binder to Hold Bulletins . . . On Request

WRITE NOW FOR "CRYSTIONICS" INFORMATION AND BULLETIN

©1944

VALPEY

Crystal Corp.

CRAFTSMANSHIP IN CRYSTALS SINCE 1931 HOLLISTON, MASSACHUSETTS

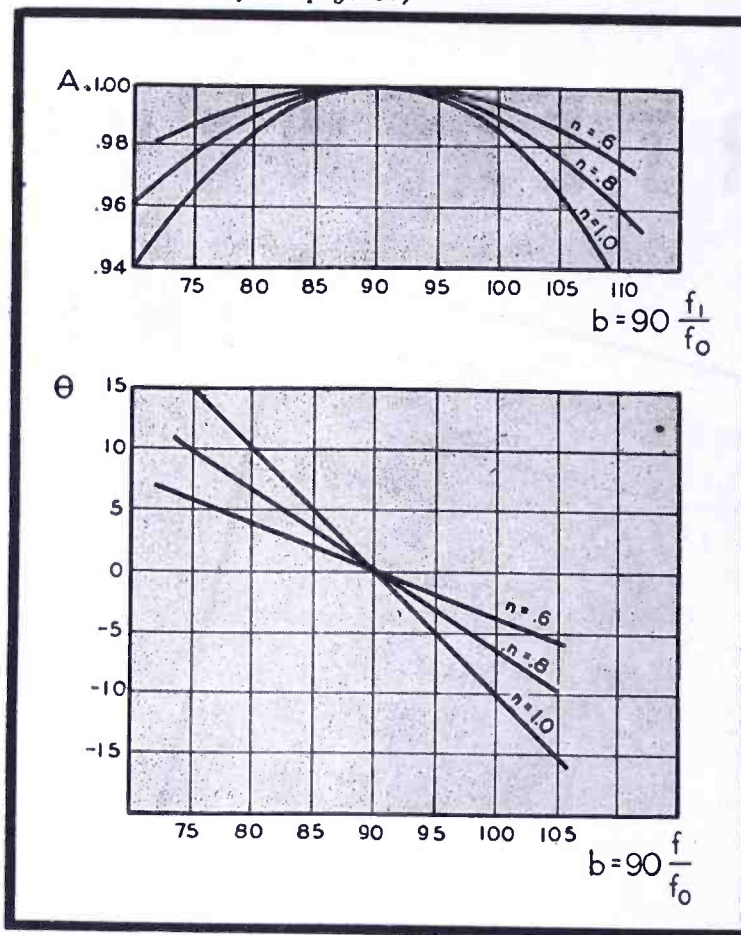

Figure 2 Curves for A and theta for a single-stub with variable n.

provement over that for n = 1.0 of roughly 0.01 db. If it be assumed that r1/r2 = 3.6 then n = 0.8 would give a value for r1/r2, for the stub, of 4.95. Also if the midfrequency, f0, is 750 megacycles, then the band from b = 80° to 100°, representing a range of about 22% of f0, is 167,000,000 cycles per second wide.

Thus far it is seen that decreasing n will produce broadbanding but it is, of course, advisable to decrease the loss, over the operating range, to a much lower value if possible. A further improvement in matching can be realized without decreasing n to any lower value by using two quarter-wavelength stubs separated by a quarter wavelength as shown in Figure 4. Here the characteristic impedance of the main line is, as before, Z0; that of the stubs is Z'0, and that of the section a-b between the stubs is Z''0. The ratio of Z0/Z'0 will again

be designated by n and the ratio of Z0/Z''0 will be represented by a. The problem is divided into two parts. The first in part (B) will make a = 1 and n = 0.8 and the second in part (C) will take a = 1.035 and n = 0.8 for reasons to be considered later.

(B)—The Two-Stub Support With a = 7.0 and n = 0.8

To obtain information concerning the degree of mismatching in this two-stub structure it is first necessary to calculate the impedance Z1 in Figure 4. This impedance is the resultant of combining the stub impedance with the Z0 of the line as in part (A). Then Z1 is used as the terminating impedance of the short section of line a-b and its input impedance is calculated. This impedance in turn is combined in parallel with that of the stub c giving a value for Zs. This pro-

(Continued on page 54)

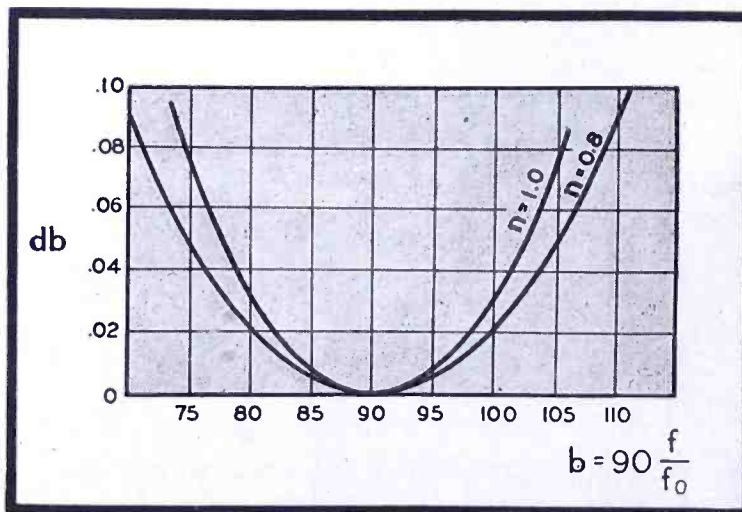
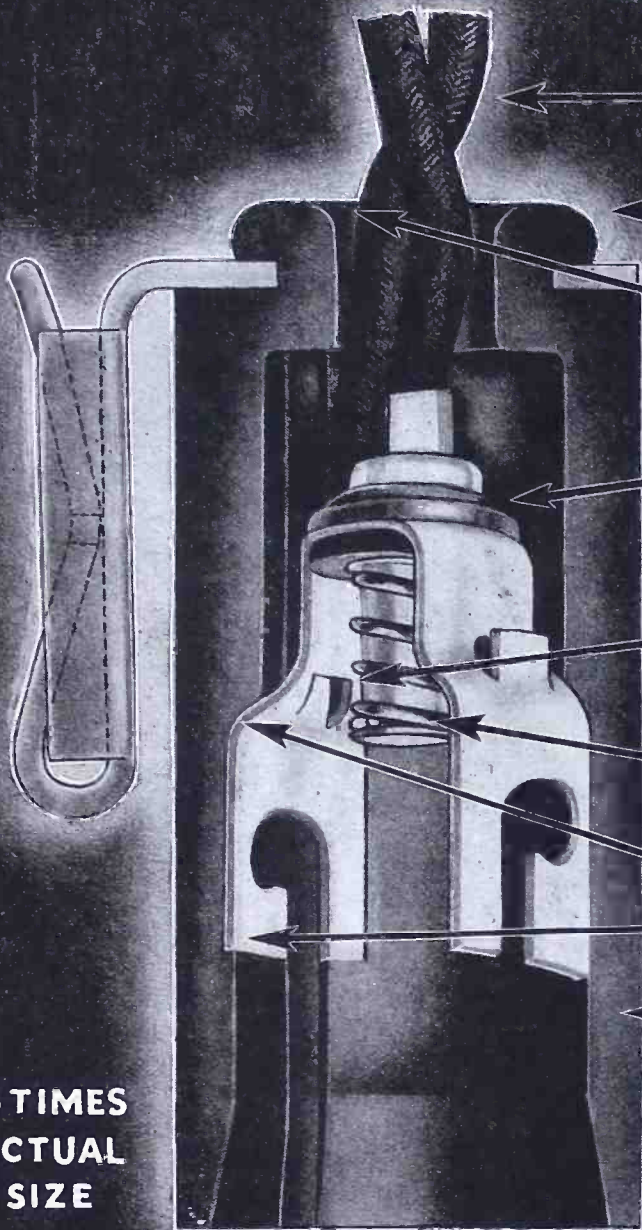

Figure 3 Loss in db for single stub for n = 1.0 and 0.8.

# *a New and Superior* DIAL LIGHT SOCKET



4 TIMES  
ACTUAL  
SIZE

Tensile strength of leads and connections far in excess of requirements.

Tough, plastic shell molded around bracket providing a secure bond with mechanical strength far beyond any normal requirement.

Rounded edge will not cut or fray wire insulation.

Voltage Breakdown between contacts—1200 Volts. Voltage Breakdown to ground—5000 Volts.

Lug on contact fits in groove in shell so that contact cannot be turned or twisted when inserting lamp.

Center contact mounted so that it cannot protrude from shell and short on chassis when lamp is removed.

Plastic shell is recessed for contacts, which cannot be pushed or pulled out of position.

Stronger, tougher, heavy walled plastic shell.

A variety of different mounting bracket styles available, suitable for practically any mounting.

## For Your Present and Post-War Production

**40TH ANNIVERSARY**  
1904-1944

This year Lenz celebrates its 40th year of service to the communications industry.

Lenz Dial Light Sockets have always been known for their superior mechanical qualities and electrical characteristics.

Now these sockets are still further improved, with even greater mechanical strength. A stronger, tougher plastic shell is attached to the bracket with a new type of construction that provides a virtually unbreakable bond between shell and bracket. Its excellent electrical characteristics are maintained.

Consider these Lenz Dial Sockets for your present and post war production. Write for sample today.



In Business

Since 1904

**LENZ ELECTRIC  
MANUFACTURING CO.**

1751 N. WESTERN AVE.

CHICAGO 47, ILLINOIS

ELECTRIC CORDS, WIRES AND CABLES

TODAY in WAR... TOMORROW in PEACE

**BRACH**

**MARINE ANTENNAS and MOUNTS**



Brach Marine Antennas and Mounts are now manufactured 100% for the service of Uncle Sam's amphibian tanks, PT boats, etc. But with the dawn of Victory we shall be ready and able to utilize our enhanced experience and wartime "know how" in supplying the civilian requirements for antenna equipment for ship-to-shore communication.

**L. S. BRACH MFG. CORP.**

World's Oldest and Largest Manufacturers of Radio Antennas and Accessories  
55-65 DICKERSON STREET • NEWARK N. J.

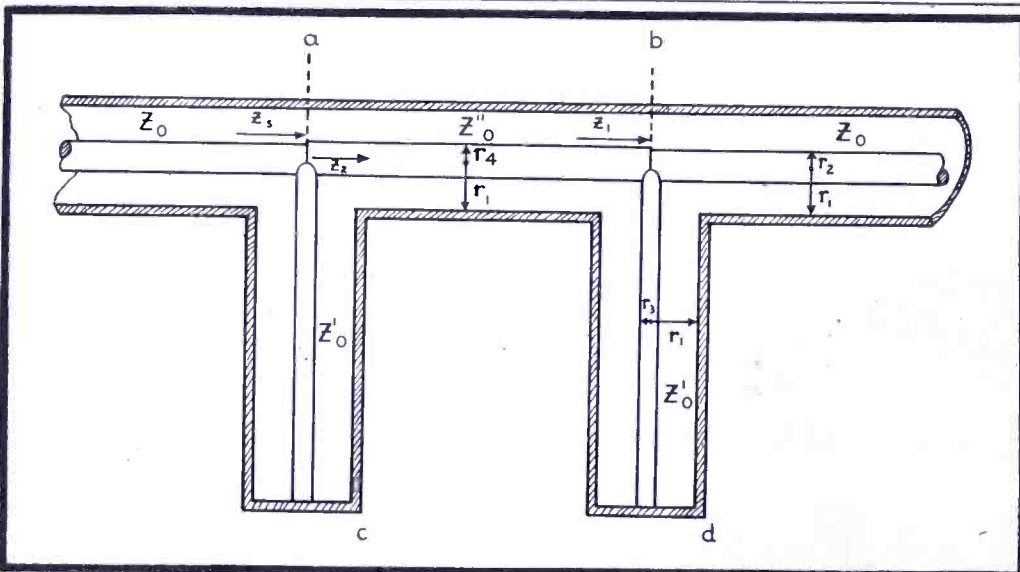

(Continued from page 52)

cedure allows the employment of two variable impedances  $Z'_0$  and  $Z''_0$  thus permitting more opportunity to make adjustments which will improve the matching conditions. The principal results are as follows:

The ratio of the input impedance  $Z_i$  to  $Z_0$  at the point  $a$  can be easily calculated to be

$$\frac{Z_i}{Z_0} = \frac{(a+n) \tan b + j \tan^2 b}{(a+n) \tan b + j (a^2 \tan^2 b - n^2 - 2an)} \quad (5)$$

$$= A / \theta^\circ \quad (6)$$

where

$$A = \sqrt{\frac{1 + \frac{(a+n)^2}{\tan^2 b}}{a^2 + \frac{(a+n)^2 - 2a^2 n (n+2a)}{\tan^2 b} + \frac{n^2 (n+2a)}{\tan^4 b}}} \quad (7)$$

and

$$\theta = \tan^{-1} \frac{a+n}{a^2} \frac{n(n+2a) - (a^2-1) \tan^2 b}{\tan b + \tan^3 b} \quad (8)$$

Through a knowledge of  $A$  and  $\theta$  in general the loss may be calculated for various values of  $b$ . In this section  $a = 1$  and  $n = 0.8$ , which substituted into equations 7 and 8, make it possible to plot the curves of Figure 5. It is noted that the phase curve tends to cross the axis with a much lower slope than in the case of the single stub and it may be expected that the attenuation curve will show much lower values in this region. The corresponding attenuation curve is plotted in Figure 9, where it is noted that a great improvement has been made at the reference points of  $b = 80^\circ$  and  $100^\circ$ . The value is now about 0.005 db instead of 0.02. A further decrease in  $n$  will improve this condition.

**(C)—Double Stub Support With  $a$  and  $n$  Arbitrary**

In the treatment of the more general case it is first necessary to inspect equation 5 with the purpose of determining the relation which must exist among  $n$ ,  $a$  and  $b$  in order to ob-

(Continued on page 84)

Figure 4  
Structure of a double-stub support.



# Setting the Standard for Fine Screen Television



**FINEST PICTURE QUALITY IN BLACK AND WHITE AND IN FULL COLOR!**

Sharper, more brilliant pictures than ever before possible are now a reality with Federal's new broad-band television technique . . .

In a revolutionary contribution to the television art, Federal's system permits combining *sight and sound* on one carrier frequency . . .

For the broadcaster — a single transmitter, and consequently, lower first cost, lower power consumption, less space requirement, and fewer high power tubes . . .

For the television audience — a

simpler, less expensive receiver, more compact and efficient, and requiring fewer tubes.

This great forward stride is the logical outcome of Federal's long list of achievements in the field and the contribution of Federal's engineers to the development of the "Micro-ray" more than a decade ago . . . the forerunner of modern television technique.

And as a result . . . Federal has been selected by the Columbia Broadcasting System for the construction

of its new television transmitter atop the Chrysler Tower in New York.

Federal's modern television technique will also be reflected in an equally advanced Federal television receiver for the home . . . producing the finest picture quality.

Federal has the experience, the facilities, the technique, needed to build television equipment for any broadcasting requirement. For the best in television — see Federal first.



## Federal Telephone and Radio Corporation



Newark 1, N. J.

**ENGINEERING  
EXPERIENCE  
and  
Manufacturing  
Facilities for**

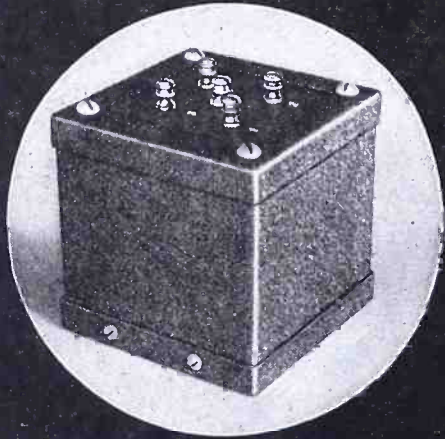

**FILAMENT TRANSFORMERS**

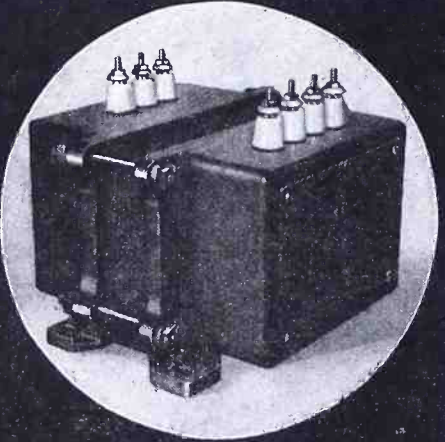

**MODULATION TRANSFORMERS**

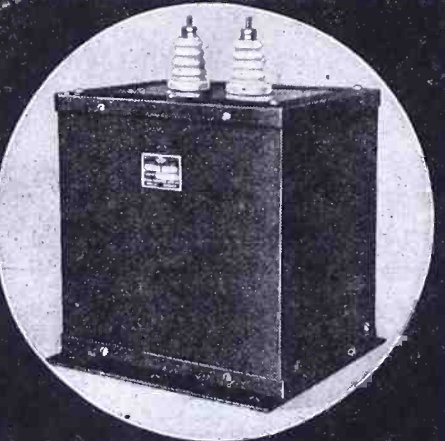

**REACTORS**

**SEND PRINTS AND  
SPECIFICATIONS IN  
CONFIDENCE FOR  
ESTIMATE**

**THE ACME ELECTRIC & MFG. CO.**  
CUBA, NEW YORK • CLYDE, NEW YORK

**Aeme Electric**  
TRANSFORMERS

**OWI TRANSMITTERS**

(Continued from page 36)

ment, is centrally located in the control room.

**R-F Generator**

The r-f signal is initiated in the r-f generator units. A battery of these run continuously. All units are identical, consisting of a 6V6 crystal-oscillator stage, two 6V6 multiplier-buffer stages and a final 807 amplifier.

The crystal-oscillator stage is of conventional design, using broadcast-type temperature controlled ovens. The plate circuit is tuned to crystal frequency. The first buffer stage operates either at crystal frequency of second, third or fourth harmonic, and the second buffer stage operates in some cases as a multiplier and in other cases as a straight amplifier, depending on the multiplication of crystal frequency required.

In all cases the 807 stage operates as a straight amplifier. The output is coupled to three parallel sets of coaxial jacks. Operating conditions are such that from one to three transmitters may be connected without affecting the drive.

Each unit is assembled on a rack-mounting 12 x 20" chassis all of which are identical. Thus any unit can operate on any frequency, when proper coils and crystals are plugged in.

Tuning the crystal oscillator and buffer amplifier stages is accomplished by midgeet variable condensers mounted inside the coil forms. The tuning condenser for the plate circuit of the 807 stage is mounted in the chassis, and is adjustable from the front panel. Thus, to set up any unit on a given frequency, it is necessary only to plug in the proper coils and crystal, and peak the tuning of the 807 stage. Figure 5 shows a rear view of one of the r-f generator units. The shield has been removed from the second buffer stage coil to show the construction.

A partial view of the equipment bays in which these generators are mounted appears in Figure 6, showing the coaxial patching panels by means of which the outputs of the generators may be patched to the inputs of the transmitter drivers. Immediately above and below the patching panels are the r-f generator unit front panels (one of which has been removed to show internal construction) with the final tuning knob to the right, tube metering push buttons grouped at the center, and crystal heat indicator at the left.

Audio monitoring of the transmitters is accomplished by speakers concealed above each transmitter. Each speaker is driven from its own amplifier. The input to this amplifier is normally fed from a diode monitor coupled to the transmitter output. By means of a switch located on the hand rail in front of the transmitter, speakers may be switched to the audio line so that comparison may be made between the signal as it enters the modulator input, and as it leaves the transmitter. Duplicate speakers are similarly located in the control room above the control desk, where monitoring is accomplished in the same manner. In addition, there are monitor level controls on the desk.

Cathode-ray oscilloscopes, which may

(Continued on page 66)

**ARPIN  
RECTIFIERS**  
MERCURY  
VAPOR  
HALF WAVE  
**575-A**  
FOR HIGH  
VOLTAGE

for

- HIGH POWER TRANSMITTERS
- INDUCTION HEATING EQUIPMENT
- SPECIAL INDUSTRIAL APPLICATIONS

**IMMEDIATE DELIVERY**

575-A is a heavy-duty half-wave rectifier tube of exceptional performance. Filament of edge-wise wound ribbon of a new alloy, giving greater thermionic emission reserve. No arc-back at full rating. Used by Signal Corps and many large manufacturers. Two tubes for full-wave rectification in single phase circuits deliver 5000 volts DC at 3 amps. with good regulation. Filament 5 volts, 10 amps. Peak Plate Current 6 amps. Peak Inverse Voltage 15,000 volts.

**WRITE FOR NEW CATALOG**

illustrating and describing the ARPIN 575-A and other tubes in the ARPIN line.

**ARPIN MANUFACTURING CO.**  
422 Alden St. Orange, N. J.

**ZOPHAR**

**WAXES  
AND  
COMPOUNDS**

FOR  
**INSULATING and WATERPROOFING  
of ELECTRICAL and  
RADIO COMPONENTS**

Also for  
**CONTAINERS and PAPER  
IMPREGNATION**

**FUNGUS RESISTANT WAXES**

**ZOPHAR WAXES and COMPOUNDS  
MEET ALL ARMY AND NAVY  
SPECIFICATIONS  
Inquiries Invited**

**ZOPHAR MILLS, INC.**  
(FOUNDED 1846)  
120 - 26th ST., BROOKLYN, N. Y.

# Here's

# VARIABLE CONDENSER

# Efficiency!

- Perfect electrical design symmetry.
- Built-in neutralization.
- Unexcelled mechanical construction.
- Built-in coil mountings with lead lengths at an absolute minimum.
- Half the length of conventional dual condensers.
- Unexcelled for use in balanced single-ended or push-pull circuits.

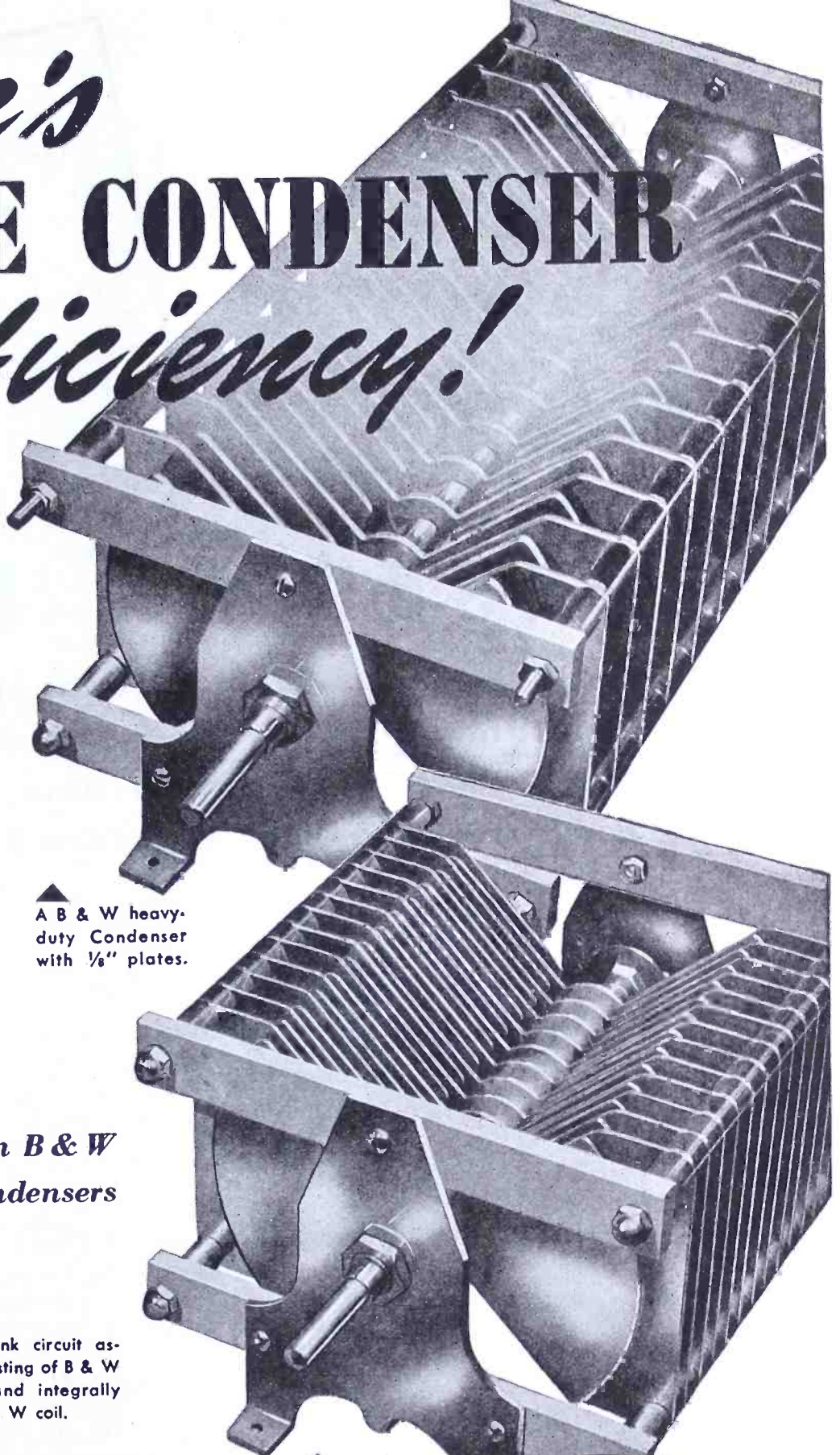

▲ A B & W heavy-duty Condenser with 1/8" plates.

Write for new Catalog 75-C on B & W Type CX heavy duty variable condensers

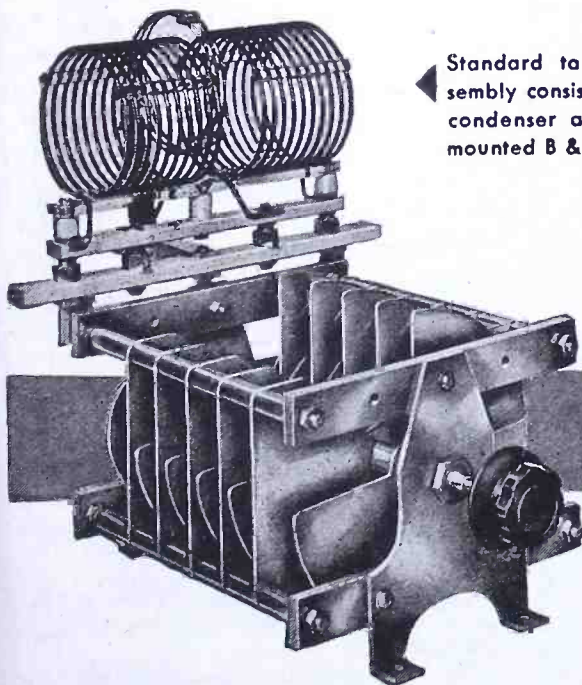

◀ Standard tank circuit assembly consisting of B & W condenser and integrally mounted B & W coil.

▲ Typical standard Type CX Condenser with 1/16" plates.

AIR INDUCTORS-VARIABLE CONDENSERS  
ELECTRONIC EQUIPMENT ASSEMBLIES



## BARKER & WILLIAMSON

Dept. C-114, 235 Fairfield Ave., Upper Darby, Pa.

Export: LINDETEVES, INC., 10 Rockefeller Plaza, New York, N. Y., U. S. A.

Figure 1  
The nominally positive directions of voltage and current at the two pairs of terminals.

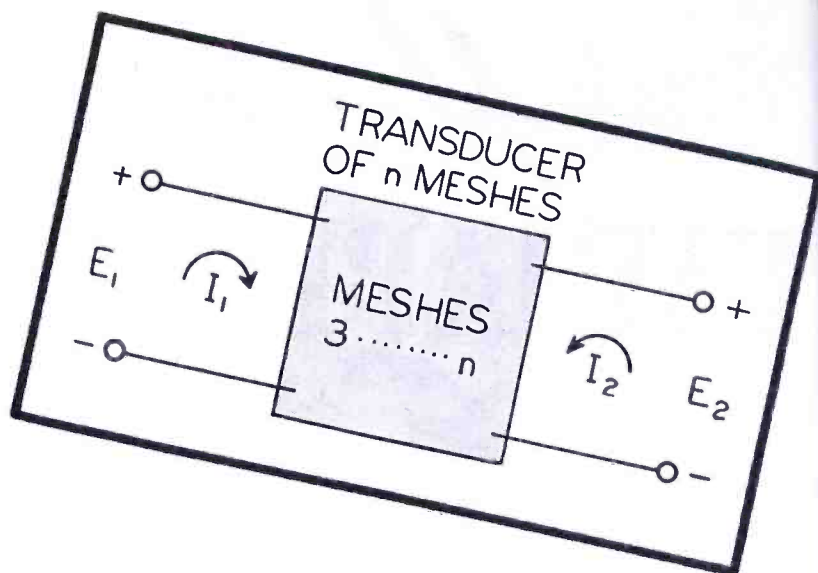

# A COMPILATION OF TRANSDUCER FORMULAE

**Relations Between  $\pi$ -Section Elements, T-Section Elements, Open-Circuit Impedances, Short-Circuit Admittances, Iterative and Image Parameters and Others, Are Tabulated In All Possible Combinations So That Any Set Can Be Found From Any Other Set**

by **W. R. MacLEAN**

Research Associate  
Polytechnic Institute of Brooklyn

**A**N electrical transducer, sometimes called a *four-pole*, is a network with two pairs of accessible terminals. Here the designation *four-pole* is not precisely what is meant, since it is essential that the four terminals be associated in two fixed pairs. Into one of the two pair, we send energy and from the other pair we receive. The networks considered in the presentation are the simple linear passive ones. That is, they contain only coils, resistors, and condensers.

The complete performance characteristics of such a transducer is, of course, known if its internal structure is specified. The structure would consist of any number of meshes,  $n$ , each containing  $L$ ,  $R$ ,  $C$ , and coupled together in any manner. We designate one of the pairs of accessible terminals as 1, and the other as 2, and identify the meshes of the internal structure so that the circuit through terminals 1 is contained in mesh 1 and in that only. Similarly, terminals 2 are contained only in mesh 2.

By the standard method of solving polymesh networks for the various

steady-state currents under the action of single-frequency driving forces, we have  $n$  equations in the  $n$  unknown currents, involving the terminal voltage  $E_1$ , at terminals 1, and  $E_2$  at 2. There are no other emf's to consider since the internal structure is passive. In Figure 1 appears the nominally positive directions of voltage and current at the two pairs of terminals.

The  $n$  simultaneous equations could be solved for the  $n$  currents by the regular process of determinants. In general, however, we are not interested in the currents in the internal meshes, but only those in meshes 1 and 2. To determine these for given terminal voltages, we would have to compute the determinant,  $\Delta$ , and certain of its minors<sup>1</sup>,  $\Delta_{11}$ ,  $\Delta_{12}$ , etc.

If now at any single frequency, it is desired to know the *external* behavior of the transducer to varying conditions of loading, it is not necessary to return to  $n$  simultaneous equations, or even to the  $n$ -rowed determinant,  $\Delta$ . A complete description of this external behavior can be obtained from *three* quantities; for instance, from the three impedances which make up the equivalent  $T$

section. In general, these  $T$ -section impedances will be functions of the frequency.

The  $T$ -section impedances are not the only set which describe the behavior of a transducer under varying load; there are the  $\pi$ -section impedances also. In all there are eight or more sets of such quantities which are useful in communications engineering. The relations that exist between the eight most useful sets are presented in a chart in this paper, and in such a tabular form that one can observe immediately how any set may be expressed in terms of any other set or in terms of the system determinant,  $\Delta$ , and its various minors. For those doing any amount of work involving transducers, such a chart is quite useful. A portion of the chart (using somewhat different designations) was first presented by G. A. Campbell in his famous article *Cisoidal Oscillations*<sup>2</sup>. The rest of the formulae are, of course, to be found in some texts<sup>3</sup>, but not usually as a convenient tabulation.

### Chart Use Guide

As a guide to the use of the chart,

<sup>1</sup>The minor  $\Delta_{12}$ , for instance, is the determinant that remains when the first row and second column are stricken from  $\Delta$ . Similarly  $\Delta_{11}$  is obtained by deleting the first two rows and columns.

<sup>2</sup>Trans. AIEE, 30, pp. 873-909 (1911); or *Collected Papers*, an A. T. & T. publication.

<sup>3</sup>E. A. Guillemin, *Communication Networks*, J. Wiley & Sons.

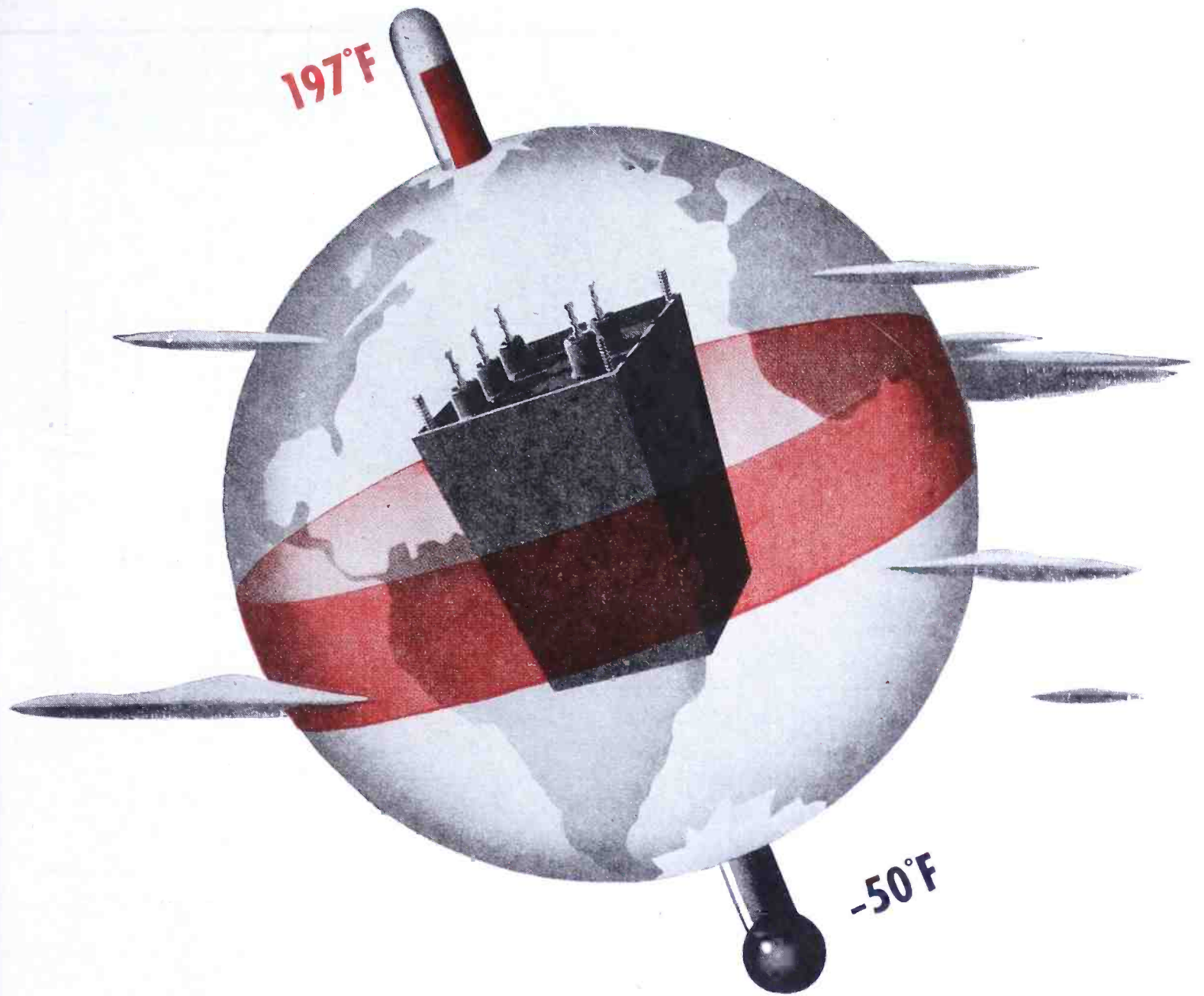

## Torture Test — **DOUBLED!**

The story of a transformer yanked back and forth from Pole to Equator

Men of the U. S. Army Signal Corps say that no matter where they run their lines, "It's either too hot or too cold." To make sure equipment can take it, the Corps runs the five-cycle humidity test.

They were giving this test to a Thermador transformer. They put it into a chamber, pressed a button to get the bleak 50° below. They pressed another button, the thermometer shot to the 197° of a blazing equatorial noon. Five times they raised and lowered the temperature. They watched, through the glass doors, water dripping onto the transformers—condensation.

After forty-eight hours they took an ice pick to get at the terminals.

They wiped them dry, connected the current, threw

on the switch. If, after this torture, the transformer could take 2,000 volts it would pass the test. They gave it not 2,000 but 4,000 volts, doubling the test—and, of course, it took it!

BUY MORE WAR BONDS!

THERMADOR ELECTRICAL MANUFACTURING CO.

5119 South Riverside Drive • Los Angeles



**THERMADOR  
TRANSFORMERS**

DEFEAT HEAT COLD HUMIDITY



	SHORT CIRCUIT ADMITTANCES	OPEN CIRCUIT IMPEDANCES	T-SECTION ELEMENTS	Π-SECTION ELEMENTS
	$Y_{11}$ $Y_{22}$ $Y_{12}$	$Z_{11}$ $Z_{22}$ $Z_{12}$	$T_1$ $T_2$ $T_{12}$	$\Pi_1$ $\Pi_2$ $\Pi_{12}$
$Y_{11} =$	$\frac{\Delta_{11}}{\Delta}$	$\frac{Z_{22}}{Z_{11}Z_{22} - Z_{12}^2}$	$\frac{T_2 + T_{12}}{T_1T_2 + T_1T_{12} + T_2T_{12}}$	$\frac{\Pi_1 + \Pi_{12}}{\Pi_1\Pi_{12}}$
$Y_{22} =$	$\frac{\Delta_{22}}{\Delta}$	$\frac{Z_{11}}{Z_{11}Z_{22} - Z_{12}^2}$	$\frac{T_1 + T_{12}}{T_1T_2 + T_1T_{12} + T_2T_{12}}$	$\frac{\Pi_2 + \Pi_{12}}{\Pi_2\Pi_{12}}$
$Y_{12} =$	$\frac{-\Delta_{12}}{\Delta}$	$\frac{-Z_{12}}{Z_{11}Z_{22} - Z_{12}^2}$	$\frac{-T_{12}}{T_1T_2 + T_1T_{12} + T_2T_{12}}$	$\frac{-1}{\Pi_{12}}$
$Z_{11} =$	$\frac{Y_{22}}{Y_{11}Y_{22} - Y_{12}^2}$	$\frac{\Delta_{22}}{\Delta_{11 \cdot 22}}$	$T_1 + T_{12}$	$\frac{\Pi_1(\Pi_2 + \Pi_{12})}{\Pi_1 + \Pi_2 + \Pi_{12}}$
$Z_{22} =$	$\frac{Y_{11}}{Y_{11}Y_{22} - Y_{12}^2}$	$\frac{\Delta_{11}}{\Delta_{11 \cdot 22}}$	$T_2 + T_{12}$	$\frac{\Pi_2(\Pi_1 + \Pi_{12})}{\Pi_1 + \Pi_2 + \Pi_{12}}$
$Z_{12} =$	$\frac{-Y_{12}}{Y_{11}Y_{22} - Y_{12}^2}$	$\frac{\Delta_{12}}{\Delta_{11 \cdot 22}}$	$T_{12}$	$\frac{\Pi_1\Pi_2}{\Pi_1 + \Pi_2 + \Pi_{12}}$
$T_1 =$	$\frac{Y_{22} + Y_{12}}{Y_{11}Y_{22} - Y_{12}^2}$	$Z_{11} - Z_{12}$	$\frac{\Delta_{22} - \Delta_{12}}{\Delta_{11 \cdot 22}}$	$\frac{\Pi_1\Pi_{12}}{\Pi_1 + \Pi_2 + \Pi_{12}}$
$T_2 =$	$\frac{Y_{11} + Y_{12}}{Y_{11}Y_{22} - Y_{12}^2}$	$Z_{22} - Z_{12}$	$\frac{\Delta_{11} - \Delta_{12}}{\Delta_{11 \cdot 22}}$	$\frac{\Pi_2\Pi_{12}}{\Pi_1 + \Pi_2 + \Pi_{12}}$
$T_{12} =$	$\frac{-Y_{12}}{Y_{11}Y_{22} - Y_{12}^2}$	$Z_{12}$	$\frac{\Delta_{12}}{\Delta_{11 \cdot 22}}$	$\frac{\Pi_1\Pi_2}{\Pi_1 + \Pi_2 + \Pi_{12}}$
$\Pi_1 =$	$\frac{1}{Y_{11} + Y_{12}}$	$\frac{Z_{11}Z_{22} - Z_{12}^2}{Z_{22} - Z_{12}}$	$\frac{T_1T_2 + T_1T_{12} + T_2T_{12}}{T_2}$	$\frac{\Delta}{\Delta_{11} - \Delta_{12}}$
$\Pi_2 =$	$\frac{1}{Y_{22} + Y_{12}}$	$\frac{Z_{11}Z_{22} - Z_{12}^2}{Z_{11} - Z_{12}}$	$\frac{T_1T_2 + T_1T_{12} + T_2T_{12}}{T_1}$	$\frac{\Delta}{\Delta_{22} - \Delta_{12}}$
$\Pi_{12} =$	$\frac{-1}{Y_{12}}$	$\frac{Z_{11}Z_{22} - Z_{12}^2}{Z_{12}}$	$\frac{T_1T_2 + T_1T_{12} + T_2T_{12}}{T_{12}}$	$\frac{\Delta}{\Delta_{12}}$
$K_1 =$	$\sqrt{\frac{1}{Y_{11}Y_{22} - Y_{12}^2} + \left[ \frac{Y_{22} - Y_{11}}{2(Y_{11}Y_{22} - Y_{12}^2)} \right]^2} + \frac{Y_{22} - Y_{11}}{2(Y_{11}Y_{22} - Y_{12}^2)}$	$\sqrt{\left( \frac{Z_{11} + Z_{22}}{2} \right)^2 - Z_{12}^2} + \frac{Z_{11} - Z_{22}}{2}$	$\sqrt{\frac{(T_1 + T_2)(T_1 + T_2 + 4T_{12})}{4}} + \frac{T_1 - T_2}{2}$	$\frac{\sqrt{\Pi_{12}(\Pi_1 + \Pi_2)(\Pi_1\Pi_{12} + \Pi_2\Pi_{12} + 4\Pi_1\Pi_2)} + (\Pi_1 - \Pi_2)\Pi_{12}}{2(\Pi_1 + \Pi_2 + \Pi_{12})}$
$K_2 =$	$\sqrt{\frac{1}{Y_{11}Y_{22} - Y_{12}^2} + \left[ \frac{Y_{11} - Y_{22}}{2(Y_{11}Y_{22} - Y_{12}^2)} \right]^2} + \frac{Y_{11} - Y_{22}}{2(Y_{11}Y_{22} - Y_{12}^2)}$	$\sqrt{\left( \frac{Z_{11} + Z_{22}}{2} \right)^2 - Z_{12}^2} + \frac{Z_{22} - Z_{11}}{2}$	$\sqrt{\frac{(T_1 + T_2)(T_1 + T_2 + 4T_{12})}{4}} + \frac{T_2 - T_1}{2}$	$\frac{\sqrt{\Pi_{12}(\Pi_1 + \Pi_2)(\Pi_1\Pi_{12} + \Pi_2\Pi_{12} + 4\Pi_1\Pi_2)} + (\Pi_2 - \Pi_1)\Pi_{12}}{2(\Pi_1 + \Pi_2 + \Pi_{12})}$
$\Gamma =$	$\cosh^{-1} \frac{Y_{11} + Y_{22}}{2Y_{12}}$	$\cosh^{-1} \frac{Z_{11} + Z_{22}}{2Z_{12}}$	$\cosh^{-1} \frac{T_1 + T_2 + 2T_{12}}{2T_{12}}$	$\cosh^{-1} \left( 1 + \frac{(\Pi_1 + \Pi_2)\Pi_{12}}{2\Pi_1\Pi_2} \right)$
$W_1 =$	$\frac{1}{Y_{11}} \sqrt{\frac{Y_{11}Y_{22}}{Y_{11}Y_{22} - Y_{12}^2}}$	$Z_{11} \sqrt{1 - \frac{Z_{12}^2}{Z_{11}Z_{22}}}$	$\sqrt{\frac{(T_1 + T_{12})(T_1T_{12} + T_2T_{12} + T_1T_2)}{T_2 + T_{12}}}$	$\Pi_1 \sqrt{\frac{\Pi_{12}(\Pi_2 + \Pi_{12})}{(\Pi_1 + \Pi_{12})(\Pi_1 + \Pi_2 + \Pi_{12})}}$
$W_2 =$	$\frac{1}{Y_{22}} \sqrt{\frac{Y_{11}Y_{22}}{Y_{11}Y_{22} - Y_{12}^2}}$	$Z_{22} \sqrt{1 - \frac{Z_{12}^2}{Z_{11}Z_{22}}}$	$\sqrt{\frac{(T_2 + T_{12})(T_1T_{12} + T_2T_{12} + T_1T_2)}{T_1 + T_{12}}}$	$\Pi_2 \sqrt{\frac{\Pi_{12}(\Pi_1 + \Pi_{12})}{(\Pi_2 + \Pi_{12})(\Pi_1 + \Pi_2 + \Pi_{12})}}$
$\Theta =$	$\cosh^{-1} \frac{\sqrt{Y_{11}Y_{22}}}{Y_{12}}$	$\cosh^{-1} \sqrt{\frac{Z_{11}Z_{22}}{Z_{12}^2}}$	$\cosh^{-1} \sqrt{\frac{(T_1 + T_{12})(T_2 + T_{12})}{T_{12}^2}}$	$\cosh^{-1} \sqrt{\frac{(\Pi_2 + \Pi_{12})(\Pi_1 + \Pi_{12})}{\Pi_1\Pi_2}}$
$A =$	$\frac{-Y_{22}}{Y_{12}}$	$\frac{Z_{11}}{Z_{12}}$	$\frac{T_1 + T_{12}}{T_{12}}$	$\frac{\Pi_2 + \Pi_{12}}{\Pi_2}$
$B =$	$\frac{-1}{Y_{12}}$	$\frac{Z_{11}Z_{22} - Z_{12}^2}{Z_{12}}$	$\frac{T_1T_2 + T_1T_{12} + T_2T_{12}}{T_{12}}$	$\Pi_{12}$
$C =$	$\frac{-Y_{11}Y_{22} - Y_{12}^2}{Y_{12}}$	$\frac{1}{Z_{12}}$	$\frac{1}{T_{12}}$	$\frac{\Pi_1 + \Pi_2 + \Pi_{12}}{\Pi_1\Pi_2}$
$D =$	$\frac{-Y_{11}}{Y_{12}}$	$\frac{Z_{22}}{Z_{12}}$	$\frac{T_2 + T_{12}}{T_{12}}$	$\frac{\Pi_1 + \Pi_{12}}{\Pi_1}$

the following definitions of the quantities that appear are presented:

**Short-Circuit Admittances:**  $Y_{11}$ ,  $Y_{22}$ ,  $Y_{12}$

- $Y_{11}$ : admittance at 1, with 2 shorted
- $Y_{22}$ : admittance at 2, with 1 shorted
- $Y_{12}$ : ratio of receiving current at 1 shorted to driving voltage at 2

Due to the linear nature of the network, the quantity  $Y_{21}$  is the same as  $Y_{12}$ . This is true for all double

Chart of transducer formulæ (other portion appears on page 62). In rows 5 and 6, one has a choice of two impedances for each K or W. Corresponding these are two values of  $\Theta$  and  $\Gamma$ .

index quantities which follow; hence it is only necessary to mention one of them. The voltage and current at the two ends are related by a pair of

linear equations involving these admittances

$$\begin{aligned} I_1 &= Y_{11}E_1 + Y_{12}E_2 \\ I_2 &= Y_{21}E_1 + Y_{22}E_2 \end{aligned} \quad (1)$$

**Open-Circuit Impedances:**  $Z_{11}$ ,  $Z_{22}$ ,  $Z_{12}$

- $Z_{11}$ : impedance at 1, with 2 open
- $Z_{22}$ : impedance at 2, with 1 open
- $Z_{12}$ : ratio of receiving voltage at 1 open to driving current at 2

These quantities also relate the two

# WELDING CAPACITORS

*for capacitor  
discharge-type equipment*

SPRAGUE

SPRAGUE

- Uniform voltage stress
- Low max. voltage gradient
- Contacts **SOLDERED** to foil  
— internal arcs avoided

Working closely with leading welding equipment manufacturers in the rapid development of Capacitor-Discharge units, Sprague has produced a line of specially-designed capacitors that have proved eminently successful in this exacting application. The dielectric of these Sprague Welding Capacitors is a high-quality

paper impregnated with an oil specially processed to assure a more nearly uniform stress throughout the units and a lower maximum voltage gradient. Longer life is the natural result. A special construction feature wherein contacts are painstakingly *soldered* to the foil minimizes danger of internal arcs with consequent gaseous discharges that might eventually ruin the capacitors.

For the latest developments in this field—whether for original capacitor-discharge welding equipment or replacement purposes—*write Sprague.*

**SPRAGUE ELECTRIC CO., North Adams, Mass.**  
(Formerly Sprague Specialties Co.)

# SPRAGUE

## CAPACITORS \* KOOLOHM RESISTORS

ITERATIVE PARAMETERS			IMAGE PARAMETERS			TANDEM PARAMETERS				REALIZABLE IMPEDANCES			
$K_1$	$K_2$	$\Gamma$	$W_1$	$W_2$	$\theta$	A	B	C	D	$S_1$	$S_2$	$O_1$	$O_2$
$\frac{(K_1+K_2) \coth \Gamma + (K_2-K_1)}{2K_1K_2}$	$\frac{(K_1+K_2) \coth \Gamma + (K_1-K_2)}{2K_1K_2}$	$-\frac{K_1+K_2}{2K_1K_2 \sinh \Gamma}$	$\frac{\pm}{W_1 \tanh \theta}$	$\frac{\pm}{W_2 \tanh \theta}$	$-\frac{1}{\sqrt{W_1W_2} \sinh \theta}$		$\frac{D}{B}$			$\frac{1}{S_1}$			$= Y_{11}$
$\frac{(K_1+K_2) \coth \Gamma + (K_1-K_2)}{2K_1K_2}$	$\frac{(K_1+K_2) \coth \Gamma + (K_2-K_1)}{2K_1K_2}$	$-\frac{K_1+K_2}{2K_1K_2 \sinh \Gamma}$	$\frac{\pm}{W_1 \tanh \theta}$	$\frac{\pm}{W_2 \tanh \theta}$	$-\frac{1}{\sqrt{W_1W_2} \sinh \theta}$		$\frac{A}{B}$			$\frac{1}{S_2}$			$= Y_{22}$
$\frac{(K_1+K_2) \coth \Gamma + (K_2-K_1)}{2K_1K_2}$	$\frac{(K_1+K_2) \coth \Gamma + (K_1-K_2)}{2K_1K_2}$	$-\frac{K_1+K_2}{2K_1K_2 \sinh \Gamma}$	$\frac{\pm}{W_1 \tanh \theta}$	$\frac{\pm}{W_2 \tanh \theta}$	$-\frac{1}{\sqrt{W_1W_2} \sinh \theta}$		$\frac{-1}{B}$			$-\frac{\sqrt{O_1(O_2-S_2)}}{S_2O_1}$			$= Y_{12}$
$\frac{K_1+K_2}{2} \coth \Gamma + \frac{K_1-K_2}{2}$	$\frac{K_1+K_2}{2} \coth \Gamma + \frac{K_2-K_1}{2}$	$\frac{K_1+K_2}{2 \sinh \Gamma}$	$\pm W_1 \coth \theta$	$\pm W_2 \coth \theta$	$\frac{\sqrt{W_1W_2}}{\sinh \theta}$	$\frac{A}{C}$				$O_1$			$= Z_{11}$
$\frac{K_1+K_2}{2} \coth \Gamma + \frac{K_1-K_2}{2}$	$\frac{K_1+K_2}{2} \coth \Gamma + \frac{K_2-K_1}{2}$	$\frac{K_1+K_2}{2 \sinh \Gamma}$	$\pm W_1 \coth \theta$	$\pm W_2 \coth \theta$	$\frac{\sqrt{W_1W_2}}{\sinh \theta}$	$\frac{D}{C}$				$O_2$			$= Z_{22}$
$\frac{K_1+K_2}{2} \coth \Gamma + \frac{K_1-K_2}{2}$	$\frac{K_1+K_2}{2} \coth \Gamma + \frac{K_2-K_1}{2}$	$\frac{K_1+K_2}{2 \sinh \Gamma}$	$\pm W_1 \coth \theta$	$\pm W_2 \coth \theta$	$\frac{\sqrt{W_1W_2}}{\sinh \theta}$	$\frac{1}{C}$				$\sqrt{O_1(O_2-S_2)}$			$= Z_{12}$
$\frac{K_1+K_2}{2} \tanh \frac{\Gamma}{2} + \frac{K_1-K_2}{2}$	$\frac{K_1+K_2}{2} \tanh \frac{\Gamma}{2} + \frac{K_2-K_1}{2}$	$\frac{K_1+K_2}{2 \sinh \Gamma}$	$\sqrt{W_1W_2} \frac{\sqrt{W_1/W_2} \cosh \theta - 1}{\sinh \theta}$	$\sqrt{W_1W_2} \frac{\sqrt{W_2/W_1} \cosh \theta - 1}{\sinh \theta}$	$\frac{1}{\sinh \theta}$	$\frac{A-1}{C}$				$O_1 - \sqrt{O_1(O_2-S_2)}$			$= T_{11}$
$\frac{K_1+K_2}{2} \tanh \frac{\Gamma}{2} + \frac{K_1-K_2}{2}$	$\frac{K_1+K_2}{2} \tanh \frac{\Gamma}{2} + \frac{K_2-K_1}{2}$	$\frac{K_1+K_2}{2 \sinh \Gamma}$	$\sqrt{W_1W_2} \frac{\sqrt{W_1/W_2} \cosh \theta - 1}{\sinh \theta}$	$\sqrt{W_1W_2} \frac{\sqrt{W_2/W_1} \cosh \theta - 1}{\sinh \theta}$	$\frac{1}{\sinh \theta}$	$\frac{D-1}{C}$				$O_2 - \sqrt{O_2(O_1-S_1)}$			$= T_{22}$
$\frac{K_1+K_2}{2} \tanh \frac{\Gamma}{2} + \frac{K_1-K_2}{2}$	$\frac{K_1+K_2}{2} \tanh \frac{\Gamma}{2} + \frac{K_2-K_1}{2}$	$\frac{K_1+K_2}{2 \sinh \Gamma}$	$\sqrt{W_1W_2} \frac{\sqrt{W_1/W_2} \cosh \theta - 1}{\sinh \theta}$	$\sqrt{W_1W_2} \frac{\sqrt{W_2/W_1} \cosh \theta - 1}{\sinh \theta}$	$\frac{1}{\sinh \theta}$	$\frac{1}{C}$				$\sqrt{O_1(O_2-S_2)}$			$= T_{12}$
$\frac{2K_1K_2}{(K_1+K_2) \tanh \Gamma/2 + (K_2-K_1)}$	$\frac{2K_1K_2}{(K_1+K_2) \tanh \Gamma/2 - (K_2-K_1)}$	$\frac{2K_1K_2 \sinh \Gamma}{K_1+K_2}$	$\sqrt{W_1W_2} \frac{\sinh \theta}{\sqrt{W_2/W_1} \cosh \theta - 1}$	$\sqrt{W_1W_2} \frac{\sinh \theta}{\sqrt{W_1/W_2} \cosh \theta - 1}$	$\sinh \theta$	$\frac{B}{D-1}$				$\frac{S_2O_2}{O_2 - \sqrt{O_1(O_2-S_2)}}$			$= \pi_{11}$
$\frac{2K_1K_2}{(K_1+K_2) \tanh \Gamma/2 - (K_2-K_1)}$	$\frac{2K_1K_2}{(K_1+K_2) \tanh \Gamma/2 + (K_2-K_1)}$	$\frac{2K_1K_2 \sinh \Gamma}{K_1+K_2}$	$\sqrt{W_1W_2} \frac{\sinh \theta}{\sqrt{W_1/W_2} \cosh \theta - 1}$	$\sqrt{W_1W_2} \frac{\sinh \theta}{\sqrt{W_2/W_1} \cosh \theta - 1}$	$\sinh \theta$	$\frac{B}{A-1}$				$\frac{S_2O_1}{O_1 - \sqrt{O_2(O_1-S_1)}}$			$= \pi_{22}$
$\frac{2K_1K_2 \sinh \Gamma}{K_1+K_2}$	$\frac{2K_1K_2 \sinh \Gamma}{K_1+K_2}$	$\frac{2K_1K_2 \sinh \Gamma}{K_1+K_2}$	$\sqrt{W_1W_2} \sinh \theta$	$\sqrt{W_1W_2} \sinh \theta$	$\sinh \theta$	B				$\frac{S_2O_1}{\sqrt{O_1(O_2-S_2)}}$			$= \pi_{12}$
$\sqrt{\frac{\Delta}{\Delta_{11:22}} + \left(\frac{\Delta_{22}-\Delta_{11}}{2\Delta_{11:22}}\right)^2} + \frac{\Delta_{22}-\Delta_{11}}{2\Delta_{11:22}}$	$\sqrt{\frac{\Delta}{\Delta_{11:22}} + \left(\frac{\Delta_{22}-\Delta_{11}}{2\Delta_{11:22}}\right)^2} + \frac{\Delta_{11}-\Delta_{22}}{2\Delta_{11:22}}$	$\cosh^{-1} \frac{\Delta_{11} + \Delta_{22}}{2\Delta_{12}}$	$\frac{\sqrt{(W_1+W_2)^2 \cosh^2 \theta - 4W_1W_2} \pm (W_1-W_2) \cosh \theta}{2 \sinh \theta}$	$\frac{\sqrt{(W_1+W_2)^2 \cosh^2 \theta - 4W_1W_2} \mp (W_1-W_2) \cosh \theta}{2 \sinh \theta}$	$\cosh^{-1} \left\{ \frac{W_1+W_2}{2\sqrt{W_1W_2}} \cosh \theta \right\}$	$\frac{A-D}{2C} + \frac{1}{C} \sqrt{\left(\frac{A+D}{2}\right)^2 - 1}$				$\sqrt{\left(\frac{O_1-O_2}{2}\right)^2 + O_1S_2} + \frac{O_1-O_2}{2}$			$= K_1$
$\sqrt{\frac{\Delta}{\Delta_{11:22}} + \left(\frac{\Delta_{22}-\Delta_{11}}{2\Delta_{11:22}}\right)^2} + \frac{\Delta_{11}-\Delta_{22}}{2\Delta_{11:22}}$	$\sqrt{\frac{\Delta}{\Delta_{11:22}} + \left(\frac{\Delta_{22}-\Delta_{11}}{2\Delta_{11:22}}\right)^2} + \frac{\Delta_{22}-\Delta_{11}}{2\Delta_{11:22}}$	$\cosh^{-1} \frac{\Delta_{11} + \Delta_{22}}{2\Delta_{12}}$	$\frac{\sqrt{(W_1+W_2)^2 \cosh^2 \theta - 4W_1W_2} \pm (W_1-W_2) \cosh \theta}{2 \sinh \theta}$	$\frac{\sqrt{(W_1+W_2)^2 \cosh^2 \theta - 4W_1W_2} \mp (W_1-W_2) \cosh \theta}{2 \sinh \theta}$	$\cosh^{-1} \left\{ \frac{W_1+W_2}{2\sqrt{W_1W_2}} \cosh \theta \right\}$	$\frac{D-A}{2C} + \frac{1}{C} \sqrt{\left(\frac{A+D}{2}\right)^2 - 1}$				$\sqrt{\left(\frac{O_1-O_2}{2}\right)^2 + O_1S_2} - \frac{O_1-O_2}{2}$			$= K_2$
$\cosh^{-1} \frac{\Delta_{11} + \Delta_{22}}{2\Delta_{12}}$	$\cosh^{-1} \frac{\Delta_{11} + \Delta_{22}}{2\Delta_{12}}$	$\cosh^{-1} \frac{\Delta_{11} + \Delta_{22}}{2\Delta_{12}}$	$\cosh^{-1} \left\{ \frac{W_1+W_2}{2\sqrt{W_1W_2}} \cosh \theta \right\}$	$\cosh^{-1} \left\{ \frac{W_1+W_2}{2\sqrt{W_1W_2}} \cosh \theta \right\}$	$\cosh^{-1} \left\{ \frac{W_1+W_2}{2\sqrt{W_1W_2}} \cosh \theta \right\}$	$\cosh^{-1} \frac{A+D}{2}$				$\cosh^{-1} \frac{O_1+O_2}{2\sqrt{O_1(O_2-S_2)}}$			$= \Gamma$
$\sqrt{K_1K_2} \frac{(K_1+K_2) \cosh \Gamma + (K_1-K_2) \sinh \Gamma}{(K_1+K_2) \cosh \Gamma - (K_1-K_2) \sinh \Gamma}$	$\sqrt{K_1K_2} \frac{(K_1+K_2) \cosh \Gamma - (K_1-K_2) \sinh \Gamma}{(K_1+K_2) \cosh \Gamma + (K_1-K_2) \sinh \Gamma}$	$\cosh^{-1} \sqrt{\cosh^2 \Gamma - \left(\frac{K_1-K_2}{K_1+K_2}\right)^2 \sinh^2 \Gamma}$	$\sqrt{\frac{\Delta \Delta_{22}}{\Delta_{11} \Delta_{11:22}}}$	$\sqrt{\frac{\Delta \Delta_{11}}{\Delta_{22} \Delta_{11:22}}}$	$\cosh^{-1} \frac{\sqrt{\Delta_{22} \Delta_{11}}}{\Delta_{12}} = \tanh^{-1} \sqrt{\frac{\Delta \Delta_{11:22}}{\Delta_{22} \Delta_{11}}}$	$\sqrt{\frac{AB}{CD}}$				$\sqrt{O_1S_1}$			$= W_1$
$\sqrt{K_1K_2} \frac{(K_1+K_2) \cosh \Gamma - (K_1-K_2) \sinh \Gamma}{(K_1+K_2) \cosh \Gamma + (K_1-K_2) \sinh \Gamma}$	$\sqrt{K_1K_2} \frac{(K_1+K_2) \cosh \Gamma + (K_1-K_2) \sinh \Gamma}{(K_1+K_2) \cosh \Gamma - (K_1-K_2) \sinh \Gamma}$	$\cosh^{-1} \sqrt{\cosh^2 \Gamma - \left(\frac{K_1-K_2}{K_1+K_2}\right)^2 \sinh^2 \Gamma}$	$\sqrt{\frac{\Delta \Delta_{11}}{\Delta_{22} \Delta_{11:22}}}$	$\sqrt{\frac{\Delta \Delta_{22}}{\Delta_{11} \Delta_{11:22}}}$	$\cosh^{-1} \frac{\sqrt{\Delta_{22} \Delta_{11}}}{\Delta_{12}} = \tanh^{-1} \sqrt{\frac{\Delta \Delta_{11:22}}{\Delta_{22} \Delta_{11}}}$	$\sqrt{\frac{DB}{CA}}$				$\sqrt{O_2S_2}$			$= W_2$
$\cosh^{-1} \sqrt{\cosh^2 \Gamma - \left(\frac{K_1-K_2}{K_1+K_2}\right)^2 \sinh^2 \Gamma}$	$\cosh^{-1} \sqrt{\cosh^2 \Gamma - \left(\frac{K_1-K_2}{K_1+K_2}\right)^2 \sinh^2 \Gamma}$	$\cosh^{-1} \sqrt{\cosh^2 \Gamma - \left(\frac{K_1-K_2}{K_1+K_2}\right)^2 \sinh^2 \Gamma}$	$\cosh^{-1} \frac{\sqrt{\Delta_{22} \Delta_{11}}}{\Delta_{12}} = \tanh^{-1} \sqrt{\frac{\Delta \Delta_{11:22}}{\Delta_{22} \Delta_{11}}}$	$\cosh^{-1} \frac{\sqrt{\Delta_{22} \Delta_{11}}}{\Delta_{12}} = \tanh^{-1} \sqrt{\frac{\Delta \Delta_{11:22}}{\Delta_{22} \Delta_{11}}}$	$\cosh^{-1} \frac{\sqrt{\Delta_{22} \Delta_{11}}}{\Delta_{12}} = \tanh^{-1} \sqrt{\frac{\Delta \Delta_{11:22}}{\Delta_{22} \Delta_{11}}}$	$\cosh^{-1} \sqrt{AD}$				$\tanh^{-1} \sqrt{\frac{S_1}{O_1}}$			$= \theta$
$\cosh \Gamma + \frac{K_1-K_2}{K_1+K_2} \sinh \Gamma$	$\cosh \Gamma + \frac{K_1-K_2}{K_1+K_2} \sinh \Gamma$	$\cosh \Gamma + \frac{K_1-K_2}{K_1+K_2} \sinh \Gamma$	$\sqrt{\frac{W_1}{W_2}} \cosh \theta$	$\sqrt{W_1W_2} \sinh \theta$	$\frac{1}{\sqrt{W_1W_2}} \sinh \theta$	$\frac{\Delta_{22}}{\Delta_{12}}$				$\frac{O_1}{\sqrt{O_1(O_2-S_2)}}$			$= A$
$\frac{2K_1K_2 \sinh \Gamma}{K_1+K_2}$	$\frac{2K_1K_2 \sinh \Gamma}{K_1+K_2}$	$\frac{2K_1K_2 \sinh \Gamma}{K_1+K_2}$	$\sqrt{W_1W_2} \sinh \theta$	$\sqrt{W_1W_2} \sinh \theta$	$\sqrt{W_1W_2} \sinh \theta$	$\frac{\Delta}{\Delta_{12}}$				$\frac{S_2O_2}{\sqrt{O_1(O_2-S_2)}}$			$= B$
$\frac{2}{K_1+K_2} \sinh \Gamma$	$\frac{2}{K_1+K_2} \sinh \Gamma$	$\frac{2}{K_1+K_2} \sinh \Gamma$	$\frac{1}{\sqrt{W_1W_2}} \sinh \theta$	$\frac{1}{\sqrt{W_1W_2}} \sinh \theta$	$\frac{1}{\sqrt{W_1W_2}} \sinh \theta$	$\frac{\Delta_{11:22}}{\Delta_{12}}$				$\frac{1}{\sqrt{O_1(O_2-S_2)}}$			$= C$
$\cosh \Gamma - \frac{K_1-K_2}{K_1+K_2} \sinh \Gamma$	$\cosh \Gamma - \frac{K_1-K_2}{K_1+K_2} \sinh \Gamma$	$\cosh \Gamma - \frac{K_1-K_2}{K_1+K_2} \sinh \Gamma$	$\sqrt{\frac{W_2}{W_1}} \cosh \theta$	$\sqrt{\frac{W_2}{W_1}} \cosh \theta$	$\sqrt{\frac{W_2}{W_1}} \cosh \theta$	$\frac{\Delta_{11}}{\Delta_{12}}$				$\frac{O_2}{\sqrt{O_1(O_2-S_2)}}$			$= D$

ends by equations which are the solution of (1)

$$\begin{cases} E_1 = Z_{11}I_1 + Z_{12}I_2 \\ E_2 = Z_{21}I_1 + Z_{22}I_2 \end{cases} \quad (2)$$

**T-Section Impedances:**  $T_1, T_2, T_{12}$

$T_1$ : impedance of series arm near 1  
 $T_2$ : impedance of series arm near 2  
 $T_{12}$ : impedance of shunt arm

**$\pi$ -Section Impedances:**  $\pi_1, \pi_2, \pi_{12}$

$\pi_1$ : impedance of shunt arm near 1

Chart of transducer formulæ (other portion appears on page 60). In column 6, within each square, one should use a consistent determination of any square root or  $\pm$  sign appearing.

$\pi_2$ : impedance of shunt arm near 2  
 $\pi_{12}$ : impedance of series arm

**Iterative Parameters:**  $K_1, K_2, \Gamma$

$K_1$ : iterative impedance at 1, i.e., such a value of impedance which if connected to 2 as a load would

equal the input impedance at 1. Or, the impedance at 1 of the transducer followed by an infinite chain of identical transducers in tandem.

$K_2$ : same definition as for  $K_1$ , with 1 and 2 interchanged

$\Gamma$ : natural logarithm of the ratio of one terminal voltage to the preceding one in the infinite chain just mentioned.  $\Gamma$  has the same value for transmission either way and is called the propagation constant. (Continued on page 64)



# Crystal Blanks

## TO YOUR SPECIFICATIONS

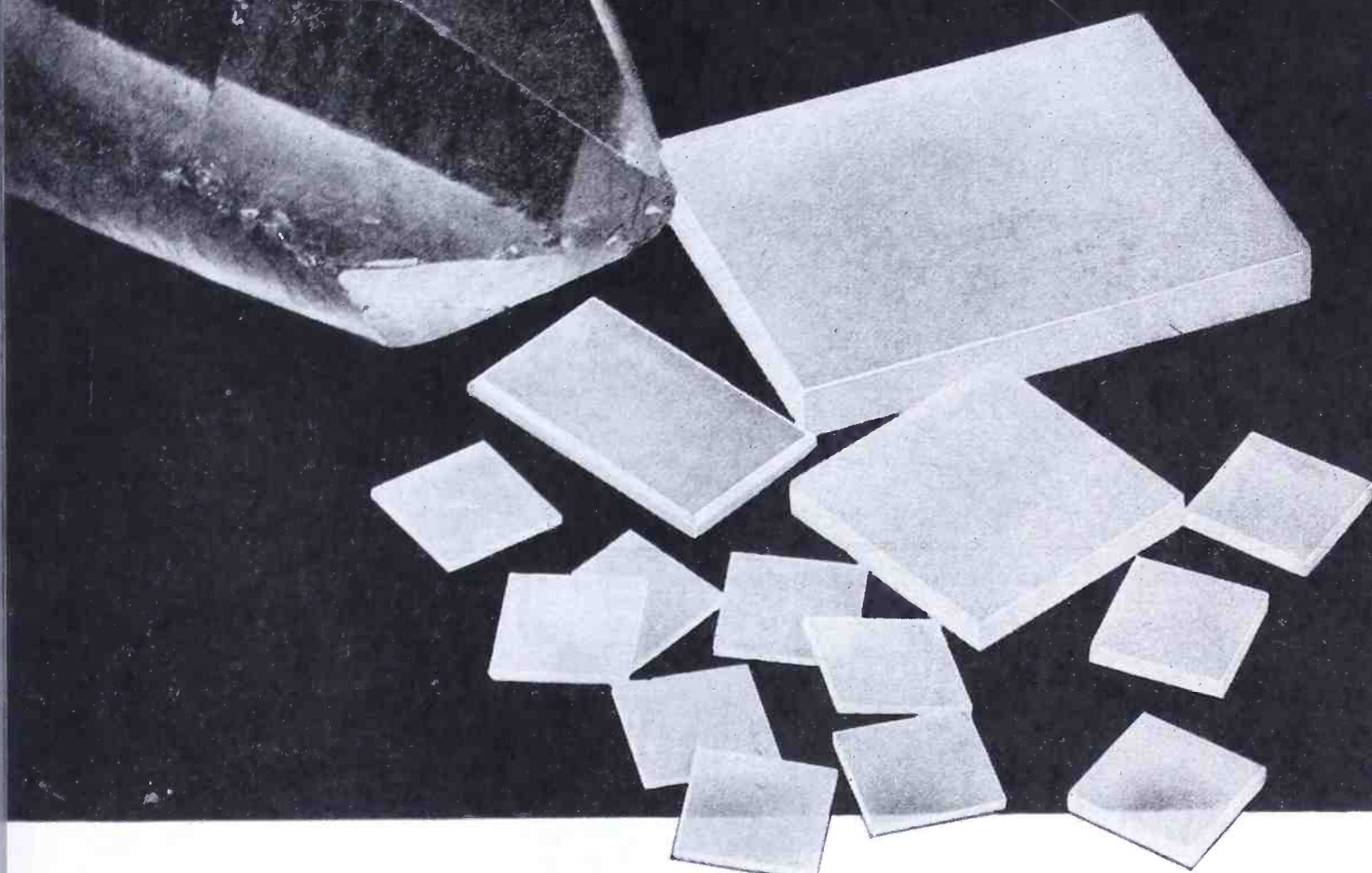

**C**rystal Products Company can supply Quartz Crystal blanks in any of the three stages of manufacture: (1) "rough-sawed" blanks, (2) "semi-finished" blanks, and (3) "electrically finished" blanks.

"Rough-sawed" blanks are cut to the specified angles and roughly sawed to dimensions.

"Semi-finished" blanks are blanks which have been brought to approximate dimensions by machine lapping, allowance being made for final hand finishing.

"Electrically-finished" blanks are finished by hand to the frequency desired and electrically tested.

All crystal blanks are cut to specifications from selected Brazilian quartz and guaranteed free from all impurities such as optical twinning, electrical twinning, bubbles, fractures, scratches, mineral inclusions, and other mechanical and electrical imperfections. Dimensions, temperature coefficients, and frequencies are guaranteed within specifications listed. **Send us your holders for replacement of crystal blanks to exact specifications.**



**Crystal**  
**PRODUCTS COMPANY**

1519 McGee Street, Kansas City, Mo.  
Producers of Approved Precision Crystals  
for Radio Frequency Control

Send for it **NOW!**

# CONCORD RADIO CORPORATION'S

*New* 16-page supplement!



## HARD-TO-GET RADIO PARTS

Listing hundreds of different and hard-to-locate components, including

- Resistors
- Condensers
- Switches
- Speakers
- Wire
- Volume Controls
- Rheostats
- Test Accessories
- Transformers
- Relays

Here's a real bonanza of radio parts. All items listed have been designated by Concord customers as "urgently needed." All are from well-known manufacturers. All are priced right. Remember, however, that they'll go fast—rush your request for this Special Supplement immediately!

Only the name has been changed! Just another reminder that the

# Lafayette Radio Corp

is now known as the  
**CONCORD RADIO CORPORATION**



For more than 22 years, the Lafayette Radio Corporation has been one of the great arsenals of the nation for radio and electronic equipment. Although we are now known as the Concord Radio Corporation, we assure you that *only the name has been changed*. Both in Chicago and Atlanta, you will find the same personnel, the same high qualities of merchandise, the same low prices, and the same reliable, speedy services as heretofore. You may shop by mail or visit us personally . . . fully confident of guaranteed satisfaction. Be sure that your name is on our mailing list for postwar catalogs, and literature. You won't want to miss the unusual developments in radio and electronics which the Concord Radio Corporation will introduce after V-Day.

*Mail Coupon Today* for the New, 16-page Supplement of "Hard-to-Get Radio Parts" by the Concord Radio Corporation!

**CONCORD RADIO CORPORATION**  
901 W. Jackson Blvd., Chicago 7, Ill., Dept. R-11  
Please rush me the new 16-page "Special Supplement" just published by the Concord Radio Corporation.

NAME .....

ADDRESS .....

CITY .....

STATE .....

# CONCORD RADIO CORPORATION

## Lafayette Radio Corporation

901 W. Jackson Blvd., CHICAGO 7, ILLINOIS ★ 265 Peachtree St., ATLANTA 3, GEORGIA

## TRANSDUCER FORMULAE

(Continued from page 62)

constant. The real part of  $\Gamma$  is the attenuation constant and the imaginary part is the phase constant.

Image Parameters:  $W_1, W_2, \Theta$

$W_1, W_2$ : Image impedances at 1 and 2. We find two values of impedance,  $W_1, W_2$ , so that with  $W_2$  as load on 2 the impedance into 1 is  $W_1$  and with  $W_1$  as load on 1 the impedance into 2 is  $W_2$ . Or,  $W_1$  is the impedance looking into 1 when the transducer is followed by an infinity of identical transducers alternately reversed so that like numbered terminals are connected together.  $W_2$  is an impedance into 2 in a similar arrangement.

$\Theta$ : half the natural logarithm of the ratio of voltage at one terminal to the preceding like numbered terminal in one of the infinite chains. The result is the same for terminals of either number and both directions of transmission.  $\Theta$  is called the transfer constant. Its real and imaginary parts are image attenuation constant and image phase constant.

Tandem Parameters

We can set up a bilinear relationship between input and output voltage and current, valid for any condition of loading by formulae, such as

$$\begin{matrix} E_2 = AE_2 - BI_2 \\ I_1 = CE_2 - LI_2 \end{matrix} \quad (3)$$

The quantities  $A, B, C,$  and  $D$  then describe the transducer. Here there are four quantities instead of three as previously, so one would not expect them to be entirely independent. This is correct, for the determinantal equation

$$\begin{vmatrix} A & B \\ C & D \end{vmatrix} = 1 \quad (4)$$

always holds.

The full usefulness of these parameters only becomes apparent when one employs matrix multiplication. In terms of matrix multiplication, (3) becomes:

$$\begin{pmatrix} E_1 \\ I_1 \end{pmatrix} = \begin{pmatrix} A & B \\ C & D \end{pmatrix} \begin{pmatrix} E_2 \\ -I_2 \end{pmatrix} \quad (5)$$

Suppose now a network  $\begin{pmatrix} A & B \\ C & D \end{pmatrix}$

is followed by a second one.

$$\begin{pmatrix} A' & B' \\ C' & D' \end{pmatrix}, \text{ then in addition to (5),}$$

there would be another equation exactly like it but with primed letters.

n such a tandem arrangement, however,  $E_2 = E'_1$  and  $-I_2 = I'_1$ . Therefore

$$\begin{pmatrix} E_1 \\ I_1 \end{pmatrix} = \begin{pmatrix} A & B \\ C & D \end{pmatrix} \begin{pmatrix} A' & B' \\ C' & D' \end{pmatrix} \begin{pmatrix} E'_2 \\ -I'_2 \end{pmatrix}$$

Or, the ABCD matrix of two transducers in tandem is the product of the individual ones. This is a very useful relation for some applications.

(5) can be solved and written as

$$\begin{pmatrix} E_2 \\ I_2 \end{pmatrix} = \begin{pmatrix} D & B \\ C & A \end{pmatrix} \begin{pmatrix} E_1 \\ -I_1 \end{pmatrix}$$

e., for the reversed transducer,  $A$  and  $D$  change places.

It is not always possible to build a two-terminal network out of a finite number of elements whose impedance could coincide at all frequencies with any of the impedances,  $1/Y_{12}$ ,  $Z_{12}$ ,  $W_1$ ,  $V_2$ ,  $K_1$ ,  $K_2$ . That is, the latter are not physically realizable. It is sometimes convenient to express network parameters in terms of physically realizable impedances.  $Z_{11}$ ,  $Z_{22}$ ,  $1/Y_{11}$ ,  $1/Y_{22}$  are four such impedances. The first column gives expressions for all other network quantities in terms of these, but for this formulation, it is convenient to introduce the letters

$$\begin{cases} 0_1 = Z_{11} \\ 0_2 = Z_{22} \\ S_1 = 1/Y_{11} \\ S_2 = 1/Y_{22} \end{cases}$$

where  $0_1$  and  $0_2$  are the open-circuit impedances looking into the two ends, and  $S_1$ ,  $S_2$ , the corresponding short-circuit impedances.

Here again there are four instead of three quantities, and hence a relation must exist between them. This relation is

$$\begin{vmatrix} 0_1 & 0_2 \\ S_1 & S_2 \end{vmatrix} = 0$$

In several cases the relationships between the various sets of parameters are not unique. This is seen in the ambiguity of sign of the square roots and of branch of the multiple valued inverse hyperbolic functions. These ambiguities are not accidental and cannot be removed.

A specification of one of the sets of parameters:  $Y$ ,  $Z$ ,  $T$ ,  $\pi$ ,  $A$ , defines

See any book on matrices. Rules sufficient for this application can be deduced from the two examples.

$$\begin{pmatrix} a & b \\ c & d \end{pmatrix} \begin{pmatrix} \alpha \\ \beta \end{pmatrix} = \begin{pmatrix} a\alpha + b\beta \\ c\alpha + d\beta \end{pmatrix} \text{ and } \begin{pmatrix} a & b \\ c & d \end{pmatrix} \begin{pmatrix} u & v \\ w & x \end{pmatrix} = \begin{pmatrix} (au + bw) & (av + bx) \\ (cu + dw) & (cv + dx) \end{pmatrix}$$

(Continued on page 66)

**"Yes, Sir!  
I heard  
every  
word!"**

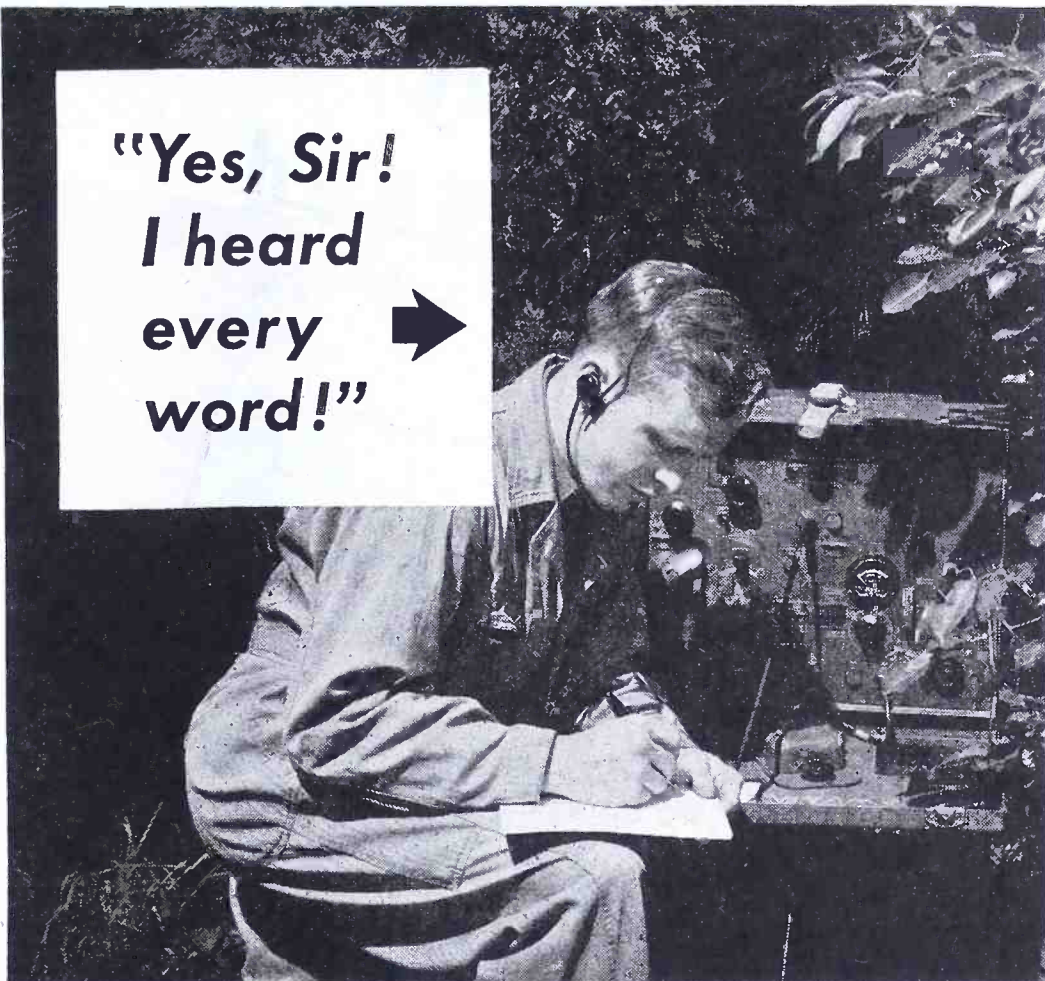

Photograph Signal Corps, U.S. Army

• IT MAY BE an urgent order for an artillery barrage or an emergency call for reserves. Whatever the message, Telex Receivers will bring it through with exceptional clearness. In serving on all war fronts Telex Magnetic Receivers have withstood a severe seasoning. Under all conditions their ruggedness and dependability have been proven.

In perfecting your product for the postwar market, let Telex engineers help you to solve your present and near future receiver or transformer problems.

In creating the first wearable Electronic Hearing Aid and in serving the U. S. Army Signal Corps they are prepared to put ingenuity and experience to work for you. Write us today.

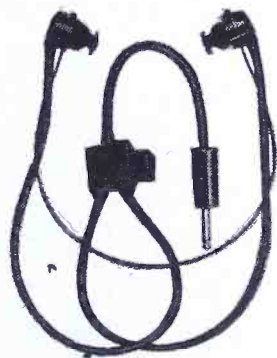

**TELEX EXPERIENCE OFFERS:**

**MAGNETIC RECEIVERS:**

**Cu. Vol.**—Approx. 0.3 cu. in.  
**Impedance**—Up to 5000 ohms.  
**Sensitivity**—18 dynes/sq. cm. for 10 microwatt input.  
**Construction**—Rugged and stable, using only finest materials, precisely machined—no diaphragm spacing washers in Telex receivers.

**TRANSFORMERS AND CHOKES:**

**Cu. Vol.**—Down to .15 cu. in.  
**Core Material**—High permeability steel alloys.  
**Windings**—To your specs. (Limit of six outside leads on smallest cores.)

ELECTRONICS PRODUCTS DIVISION

**TELEX**

**PRODUCTS COMPANY**

TELEX PARK • MINNEAPOLIS • MINNESOTA

# Individually Designed



## TO YOUR Specifications

Harnesses or other wiring assembly in your plans, now, or for the future, individually designed by HOWARD! Send your specifications to HOWARD, specialists in the design and manufacture of radio equipment.

# HOWARD MANUFACTURING CORP.

★ BUY WAR BONDS ★

COUNCIL BLUFFS, IOWA

# ...on our mark

... and set to go on Civilian production of Radio and Automotive Products—soon. Set your sights on Snyder.

**SNYDER MFG. CO.**  
RADIO & AUTOMOTIVE PRODUCTS • PHILA. 40, PA.

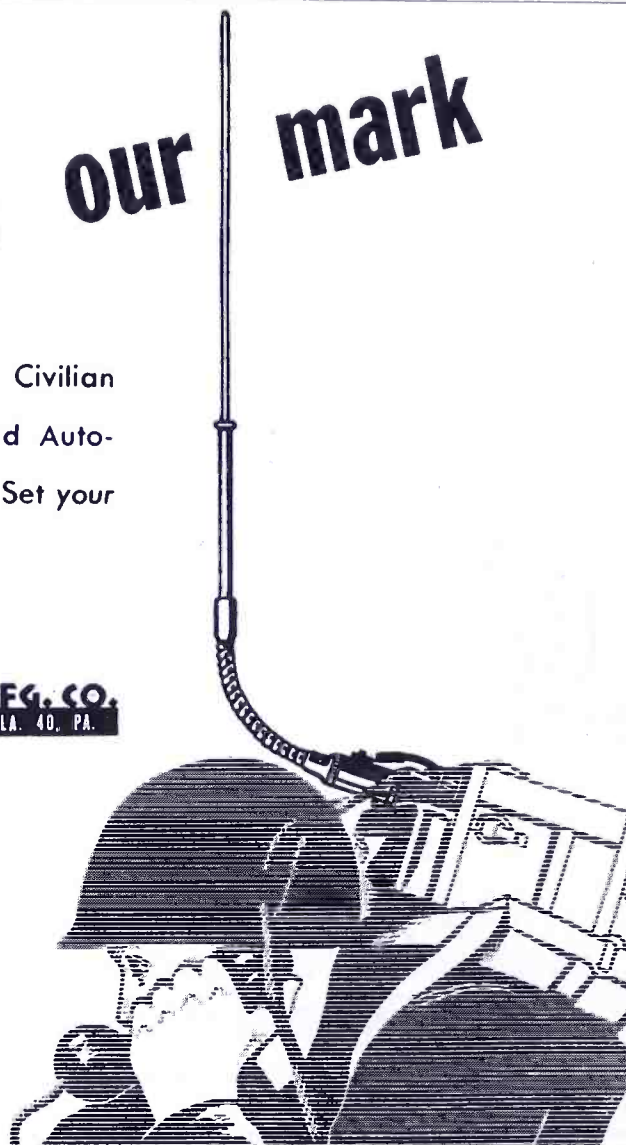

## TRANSDUCER FORMULAE

(Continued from page 65)

the performance of a network uniquely. Consequently, all the relations between this group are single valued. On the other hand, specification of the *Realizable Impedance* group leaves an ambiguity: for instance, an interchange of output wires would not change this set. Since certain changes in elements are equivalent to an inversion of leads, we have two networks for each such set. In the case of the *Image Parameter* set, there are four networks corresponding to each. Changing the sign of every element or inverting leads does not change the *Image Parameters*. Hence in column 6 of the chart there is a total of four choices in each square.

Finally every network has two image and two iterative impedances on each end. The  $\Gamma$  or  $\Theta$  corresponding to one is the negative of that corresponding to the other. This is the other value of  $\cosh^{-1}$  or  $\tanh^{-1}$ .

## OWI TRANSMITTERS

(Continued from page 56)

be seen in Figure 7, are provided for monitoring the carrier of each transmitter, and are located in the control desk. These have a 60-cycle sweep voltage on the horizontal plates; the vertical plates are fed from pre-tuned circuits, coupled by coaxial lines to the transmitter output. These tuned circuits are selected by band switch from the front of the oscilloscope. The coil assembly on each has 10 resonant circuits, each with a midrange variable condenser for resonating the circuit to any of 10 frequencies on which the associated transmitter may be operating.

Immediately below each oscilloscope panel is a small panel bearing the audio level control, the *carrier-on* light, the *emergency-off* button for each of the transmitters, and a key which, when thrown, drops the studio line, and picks up the output of a pre-set electrical transcription machine, and simultaneously, through relays, starts the transcription machine motor. To the right of the public address speaker on the center panel is a master key, which operates *all* the pre-set electrical transcription machines simultaneously.

At the center of the desk are the general controls common to all transmitters. Immediately above is the public address speaker, which also serves as a microphone, and which may be switched to a two-way f-m transmitter, communicating with the antenna service car, without being disconnected from the regular building intercommunication system. Immediately below the speaker is a volume level indicator, with its range switch and channel selector switch. Below these are the level control and selector switches for the monitoring speakers.

The frequency monitoring system is also included in the control room equipment, and consists of a secondary frequency standard, a fixed-tuned 5-mc WWV receiver, a frequency counter, and an r-f signal mixing panel.

All components of the 100-kc oscilla-  
(Continued on page 70)

*You'll Want this New*

**JAMES KNIGHTS**

*"Crystal Controlled"*

**Frequency Standard**



This is the ideal secondary frequency standard to check frequency of oscillators and transmitters, to calibrate and align receivers, etc. Can be used by the crystal manufacturer to check frequency standards for production. Useful many ways in the electronic laboratory or factory. Provides output up to 40 megacycles at 1,000, 100 and 10 kilocycle intervals. Complete cost only \$59.50. Descriptive catalog sheet on request.

**BUY WAR BONDS FOR VICTORY!**

**The JAMES KNIGHTS Co.**

**SANDWICH, ILLINOIS**

**CRYSTALS FOR THE CRITICAL**



W. J. McGONIGLE, President

RCA BUILDING, 30 Rockefeller Plaza, New York, N. Y.

GEORGE H. CLARK, Secretary



At the 77th Division Club meeting, October 25, 1944

### Personals

**A** ROUSING round of applause and congratulations to Morris Pierce for his epic deed on the western front. Thanks to his ingenuity we captured powerful Radio Luxembourg before its German occupants could destroy it.

Mr. Pierce, chief engineer of WGAR, who was serving as chief engineer of the Psychological Warfare Branch of OWI, won the plaudits of the world last year, too, by securing the surrender of the entire Italian fleet without the firing of a single shot. An old transmitter retuned from 1,100 to 500 kc did the job, and what a job!

Glad to see John W. Swanson recently. JWS started in wireless with the United Wireless Telegraph Company in 1909. He then went with the Marconi Wireless Company of America. A position with the United Fruit Company (Tropical Radio) followed. Today he is an executive in the Marine Department of the Standard Oil Company. . . . VWOA welcomes Edward J. Oberle of Allwood, N. J., who has seen service in the Navy and at WODA of Paterson, N. J. . . . We were sorry to learn of the illness of Charles E. Drew, a genuine old-timer, who recently entered the Veterans Hospital at Northport, L. I., after suffering a nervous breakdown. His most recent book, *How to Pass Radio License Examinations*, was

published April 1, 1944. We hope that we may see him around again very soon. . . . Commander Fred Muller would like to receive mail from his old friends. Contact headquarters for his address.

### The VWOA Fall Meeting

**T**HE 77th Division Club meeting on October 25, 1944, was well attended. Among those present were: Ludwig Arson, president of Radio Receptor Company; Col. Tom Mitchell, vice president and general manager of RCA Communications, and J. F. Rigby, personnel director of RCAC; C. D. Guthrie, radio supervisor of the War Shipping Administration, and Mr. Campbell of the same office; Ed Carroll, who always comes up from Philadelphia for these parties to relate those interesting stories; Carl Nelson, publisher of *Telephone and Telegraph Age*; a large delegation from the marine department of the Mackay Radio and Telegraph Company with E. H. Price, marine superintendent, and A. F. Wallis in the lead; V. P. Villandre, war services supervisor of the Radiomarine Corporation of America and our very diligent ticket committee chairman these many years; Peter Podell, one of our founders, now in the motor sales field; Frank Orth, technical supervisor of CBS; Arthur H. Lynch, eastern representative of the National Company

and general sales manager for Ercel Radio Laboratories, and chairman of our ways and means committee; A. I. Yuter, one of our most constant members; George Duvall, now with the Army Signal Corps; Bill Stedman who seldom misses a meeting; Henry Hayden, Ward Leonard representative; Roscoe Kent, one of the earliest of oldtimers, now with the Gemex Company; Martell Montgomery of Federal Telephone and Radio Corporation; Henry Steinberg, eastern representative of Cornell Dubilier; Bob Frey, radio supervisor of the Bul Steamship Lines; J. A. Bossen; and R. J. Iverson of the New York Times radio staff.

### In Memoriam

**T**WO of our veteran wirelessmen have passed away . . . Arthur Cohen, member of the staff of the American Embassy, Rio de Janeiro, and John H. Cose, assistant superintendent of RCA Institutes. Mr. Cohen was a wireless officer on the largest of American passenger vessels. He also served aboard some of the larger American Yachts. Mr. Cose served on the staff of RCA Institutes as a code instructor, and head of the Physics Department. In 1939 he assumed the position of Assistant Superintendent. . . . To the families and friends of these veteran wirelessmen we extend our deepest condolences.

# “HIGHWAYS OF THE AIR”

*Important to everyone interested in airports and aviation*

## YOU SHOULD KNOW—

What is the "bottle-neck" in post-war expansion of civil aviation . . . . . See page 8

Why CAA is installing Ultra High Frequency radio ranges. See page 8

What anti-collision devices are being developed . . . See page 9

What electronic aircraft detectors are . . . . . See page 9

What can civil aviation learn from the A.A.C.S. . . . See page 2

What goes into an instrument landing system . . . See page 11

What is approach control. See page 11



These questions and dozens of others of vital import to all those interested in the development of radio in aviation for increased safety of human life and property are discussed in the pages of

## “HIGHWAYS OF THE AIR”

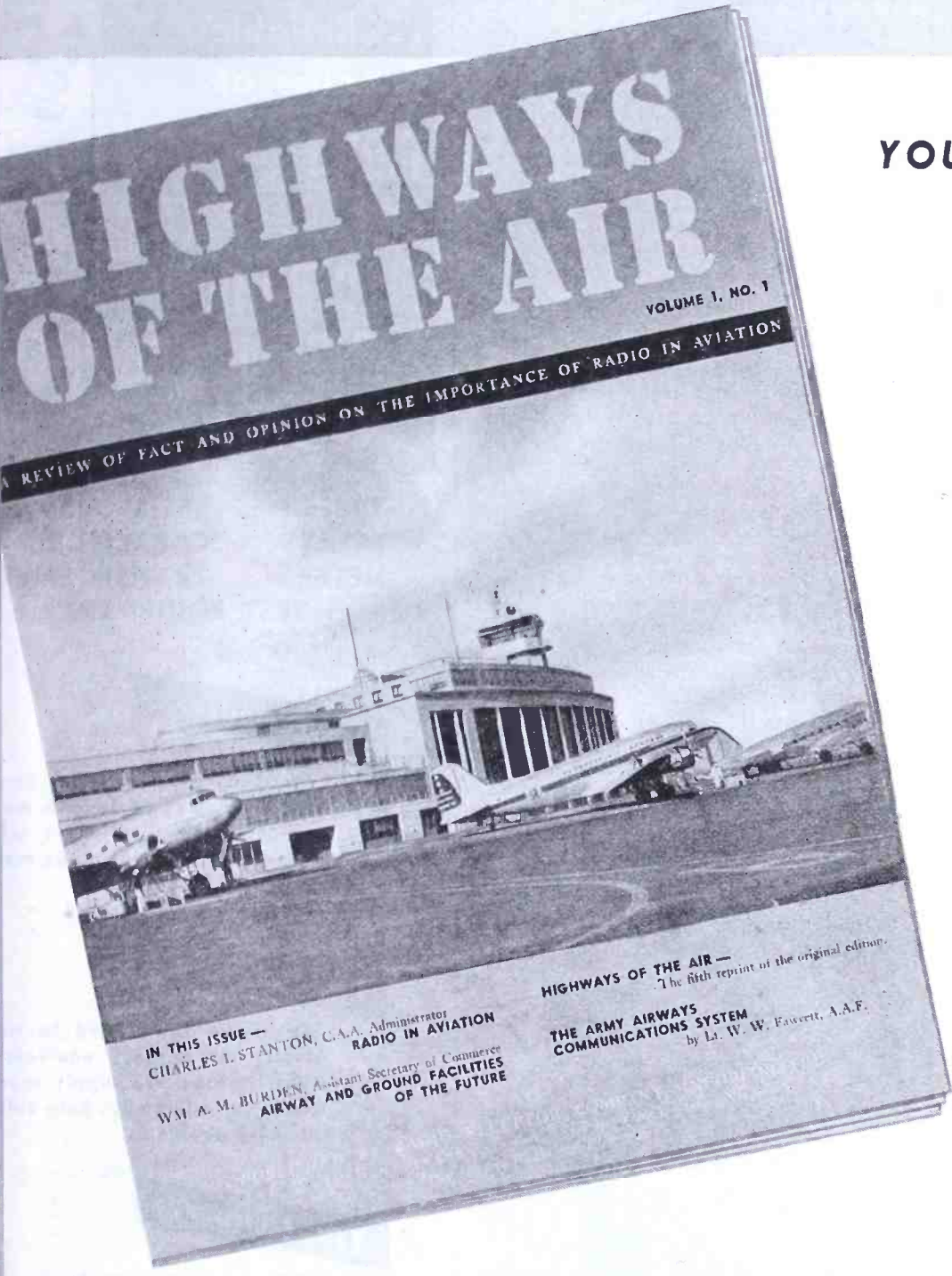

This issue is No. 1, Volume 1—others will follow if you request them. Contents are authoritative—but non-technical—designed to inform the layman on a subject which is becoming of increasing importance.

Send for your copy on your letterhead—we are glad to send it as our contribution to a greater Air-America.

# RADIO RECEPTOR CO., INC.

251 West 19th Street • New York 11, N. Y.

Engineers and Manufacturers of Airway and Airport Radio Equipment • Communications Equipment • Industrial Electronics • Electronic Heating Equipment  
S I N C E 1 9 2 2 I N R A D I O A N D E L E C T R O N I C S

*Designed for*



*Application*

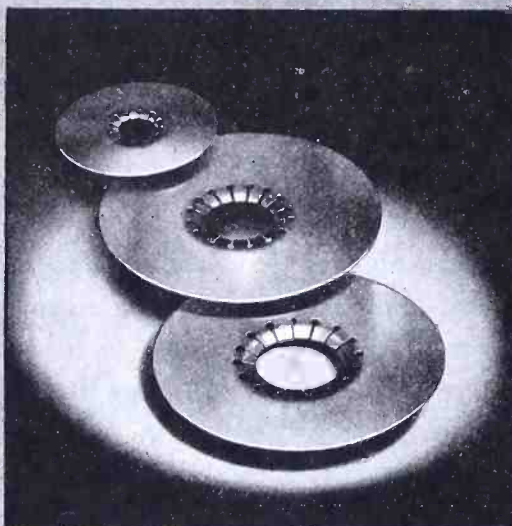

**No. 33446 — Cavity Socket Contact Discs**

Now that the Secret classification has been lifted from the General Electric type GL496 or "Lighthouse" ultra high frequency tube, we can list the cavity contact discs we have been furnishing to authorized customers during the past few years. This set consists of three different size unhardened beryllium copper multifinger contact discs. Heat treating instructions forwarded with each kit for hardening after spinning or forming to frequency requirements.

**JAMES MILLEN MFG. CO., INC.**

MAIN OFFICE AND FACTORY  
**MALDEN MASSACHUSETTS**



**OWI TRANSMITTERS**

*(Continued from page 66)*

tor circuit are enclosed in a temperature controlled oven, including the tuned circuit, the crystal, the oscillator tube, and a voltage regulator. The oscillator is electron coupled to an isolating amplifier, which feeds the output to the multivibrator and the fixed tuned WWV receiver.

The WWV receiver is a three-stage t-r-f type, fed from a tuned loop. A detector stage mixes the 100-kc signal with the WWV signal. An audio amplifier is included to drive the monitoring speaker.

The multivibrator is of conventional design, with operating frequencies at 10, 20 and 50 kc. It is preceded and followed by isolating amplifiers. The output amplifier is of cathode-follower type, feeding one stator of two signal-balancing variocouplers, in tandem, driven from a common shaft, and completely shielded from each other. A faraday shield eliminates capacity coupling between rotor and stator of each variocoupler. The rotors are so oriented on the common shaft that when coupling is at minimum in one unit, it is at maximum in the other. Multivibrator output is fed to one stator, the unknown signal is fed to the other, and the two rotors in series are fed to the input of the communications receiver. This provides a means of balancing the amplitudes of the unknown and the standard signals, so that a good beat note is obtained.

The unknown signal input to the signal balancing variocouplers may, by means of a jack panel, be obtained from one of the r-f generators, or from an antenna. The multiple-band communication receiver and frequency counter complete the equipment of the frequency-monitoring unit.

**R-F Driver**

A front view of the r-f driver, which is composed of three stages, is shown in

Figure 10

Interior of the power amplifier cabinet. Small cabinet between two tubes provides shielding for grid circuits of amplifier.

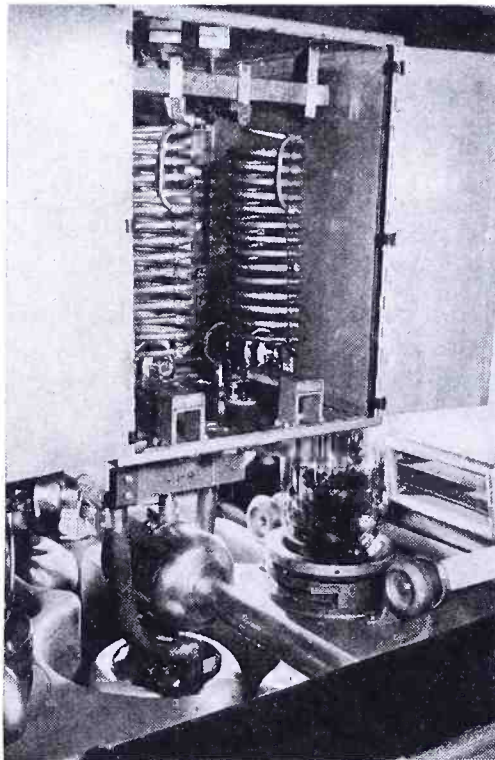

**harvey**

**... Reliable Supplier of RADIO and ELECTRONIC PARTS and EQUIPMENT**

- TUBES**
- RELAYS**
- METERS**
- RESISTORS**
- CAPACITORS**
- TRANSFORMERS**
- TEST EQUIPMENT**

**The Goods:**

We stock and sell items bearing the names of famous manufacturers... people who value their reputation as much as we value ours.

**The Service:**

We track down hard-to-find items, or suggest equivalent substitutions. We supply sound technical advice... help solve priority problems.

**The Delivery:**

Fast... within 24 hours, or times. And whether you order by mail, wire or phone, you receive immediate attention. Try HARVEY and see for yourself.

Telephone Orders to  
**LONGACRE 3-180**

**HARVEY RADIO COMPANY**

**HARVEY**

103 WEST 43rd ST., NEW YORK 18, N. Y.



Fig. 8. Each stage is separately tuned in both grid and plate circuits, and is link-coupled to the succeeding stage. Both the grid and plate circuits of the first stage, a single 807, have eight pre-tuned, plug-in coils. Each grid coil is provided with an input winding which is selectively connected to the double coaxial transmission line terminating on the r-f exciter patching panel. The push-pull 813 second stage has two sets of tapped coils in both grid and plate circuits. The F129B driver third stage is push-pull, and has two sets of tapped coils in its grid. Both these stages have adjustable tuning capacities, controlled from the front of the cabinet. The 129B plate circuit consists of a copper tubing inductance with adjustable taps and shorting bars, and a variable air condenser, visible from center front of Figure 8, controlled from front of cabinet. A ganged band switch is mounted vertically and operated from the rear of the cabinet, by means of a horizontal handwheel, accessible from the top shelf. This mechanism switches all circuits except the 129B plate circuit, which must be changed manually. Other front controls include the third stage neutralizing, and the output coupling adjustment, which is accomplished by swinging a small link coil into the field of the center of the driver plate inductance, Figure 9.

#### Final Amplifier Unit

The final amplifier of each transmitter is designed to deliver 250-kw 100% plate modulated, on frequencies between 6 mc and 21.65 mc, with plate voltage up to 15 kv. Figure 10 shows a view of the interior of the power amplifier cabinet. Mounted between the two tubes is a small cabinet which provides shielding for the grid circuits of the amplifier. The grids of these tubes are driven through a pi network, fed through coaxial transmission lines from the driver cabinet, where it is inductively coupled to the tank circuit of the driver. The doors of the grid cabinet are shown open, so that grid coils may be observed. These coils are so proportioned that the circuit is tuned at 6 mc, when the entire coil is in the circuit. By placing shorting straps across turns of the coils, higher frequencies are obtained.

(Continued on page 72)

Figure 11

Neutralizing condenser, which consists of two semi-cylindrical sections, rotated in the cylindrical space formed by tube jacket housings.

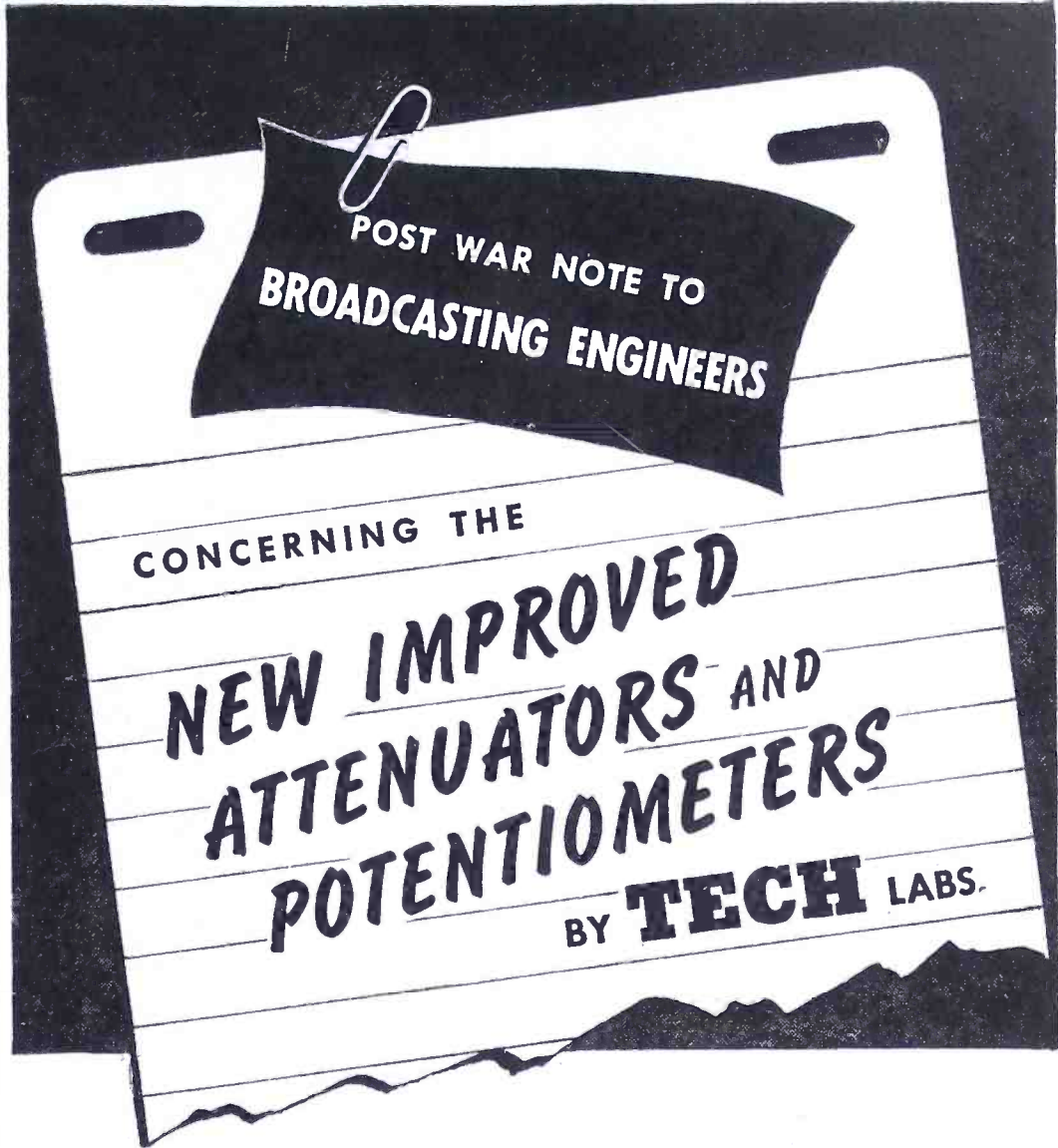
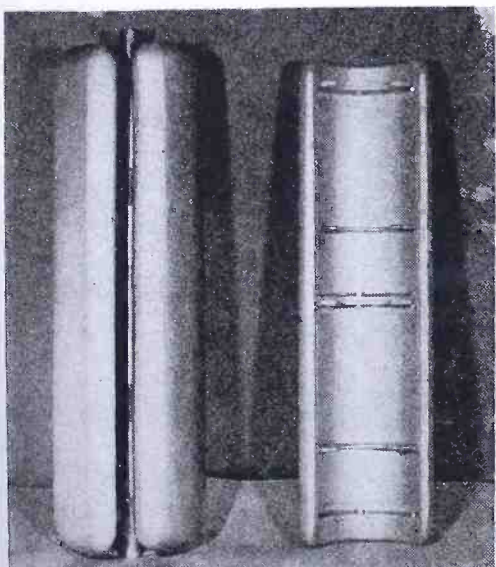

All our modern production facilities, manpower and materials are engaged in supplying our armed forces with quality electrical resistance instruments. Once the Victory has been won, Broadcast Engineers everywhere can rely on Tech. Labs. for prompt shipment on precision attenuators and potentiometers.

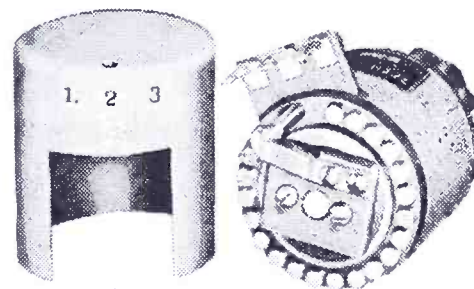

TYPE 600

- Stainless silver contacts and wiper arms eliminate the necessity of frequent cleaning and result in less noise.
- Better insulation and moisture proofing result in superior performance.
- Improved mechanical construction — pinned rotor hubs and detent gears—results in longer trouble free operation.

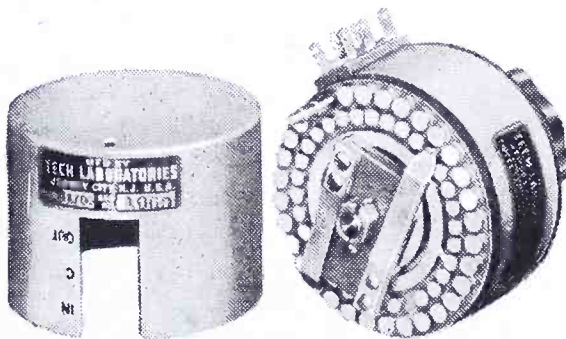

TYPE 700



MANUFACTURERS OF PRECISION  
ELECTRICAL RESISTANCE INSTRUMENTS

15 LINCOLN STREET, JERSEY CITY 7, N. J.



## Gas Filled Pressure Condensers

Johnson Engineers were among the first to design and build Gas Filled Pressure Condensers in fixed, variable, and combination fixed and variable types.

Gas Filled Condensers offer a decided advantage in size where large capacities or high voltage ratings are necessary. In some cases Gas Filled Condensers make possible an instrument that would be a mechanical impossibility in an air type.

Johnson Gas Filled Pressure Condensers are available in several sizes of housings depending on the rating specifications. Prices are low, efficiency is high, gas leakage is nil over long periods of time.

Write today for more information and prices.

**JOHNSON**  
a famous name in Radio

E. F. Johnson Co. Waseca, Minn.

(Continued from page 71)

until at 21.65 mc the entire coil is short circuited. The pi network uses the tube capacities and inductances in its circuit.

The grid circuit of the final amplifier has a fixed bias which protects the tubes to a safe value of plate dissipation, in case of failure of drive. This is accomplished by obtaining bias voltage through a high resistance from one of the low voltage rectifiers. The voltage is applied continuously, and in case of failure of drive, the tubes are automatically protected from overloads without the operation of any relays. When tubes are being driven, the bias becomes negligible.

On each side of the cabinet interior, cooling air is provided through a vertical duct, connecting with the header duct above the entire transmitter unit, and providing a blast of air on the glass of the power amplifier tubes, of sufficient velocity for effective cooling over the entire periphery of the glass.

In Figure 10, the arrangement of the neutralizing condenser and the plate tank condenser may also be seen. In the center of the picture, three concentric shafts run toward the rear of the cabinet, through a corona shield, housing bevel gears. This mechanism, operating by chain drive from controls on front of the cabinet, adjusts the plate tank condenser, the antenna coupling loop, and the neutralizing condenser.

The neutralizing condenser consists of two semi-cylindrical sections (Figure 11) rotated in the cylindrical space formed by the tube jacket housings. This design provides a balanced-bridge circuit, with essentially no detuning of grid or plate circuits during neutralization adjustments.

The plate tank circuit of the power amplifier (Figure 12) consists of a variable air condenser and a transmission line inductance with movable shorting bar. The constants of this circuit are such that a frequency range of 6 to 21.65 mc is covered by adjustment of the capacity and inductance. The moving portion of the plate tank condenser is suspended from a carriage which rides on three brass pipes. In addition, this condenser is bypassed to the shield at practically the same point to which the filaments of the tubes are bypassed. The grid cabinet is also connected to this same point. This serves to hold the circulating currents in the shielding to a minimum, and pro-

Figure 12  
Variable air condenser and transmission line inductance, with movable shorting bar in plate tank circuit of the power amplifier.

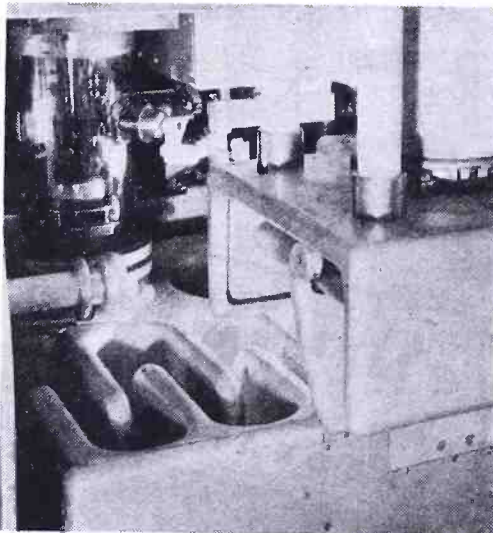

**PREMAX**

# Premax Antennas

—Tested  
in war

—Ready  
for peace

Send Today for Your Copy  
of This Interesting Booklet

*Premax Products*

Division Chisholm-Ryder Co., Inc.

4501 Highland Ave., Niagara Falls, N. Y.

*Permanent*

# MAGNETS

*By*

**Thomas & Skinner**

ALL SHAPES . . . ALL SIZES  
Cobalt • Chrome • Tungsten  
Stamped, Formed or Cast.

**ALNICO**

*(Cast or sintered, under G. E. license)*

Also: LAMINATIONS for output transformers of highest permeability. Standard stocks in a wide range of sizes for Audio, Choke, Output and Power Transformers. Write for dimension sheet. . . . TOOLS . . . DIES . . . STAMPINGS . . . HEAT TREATING.  
44 YEARS' SPECIALIZED EXPERIENCE

**Thomas & Skinner**

STEEL PRODUCTS CO.

1113 E. 23rd St., Indianapolis 5, Ind.

vides stable operation at powers in excess of 200 kw.

The stationary plates of the plate condenser are carried directly on the housings which contain the tube jackets. Figure 13 shows an assembly of tube jackets in housings, incorporating thermometers and water pressure gauges. Also shown are the antenna coupling loop, vertical section of the transmission line, and the bottom header castings to which are to be connected the horizontal four-pipe transmission line, on which the shorting bar slides. These horizontal pipes also carry cooling water to the tubes.

The transmission line tank is housed in a metal shielding duct, which is a continuation of a shield within the cabinet, but which is insulated from the metal of the cabinet itself. The vertical section of the transmission line consists of a pair of large copper pipes on each side, each pair encased in a copper sleeve. This offers an exceptionally low impedance circuit, and makes it possible to obtain a high distributed capacity, even though the conductors are separated from each other far enough to permit mounting of a coupling loop between them.

The coupling loop is in two portions: a vertical adjustable portion shown in Figure 13, and a horizontal fixed portion which runs parallel to the horizontal portion of the transmission line tank circuit.

(Continued on page 74)

Figure 13

Vertical adjustable portion of the coupling loop, which also has a horizontal fixed portion, running parallel to the horizontal portion of the transmission line tank circuit.

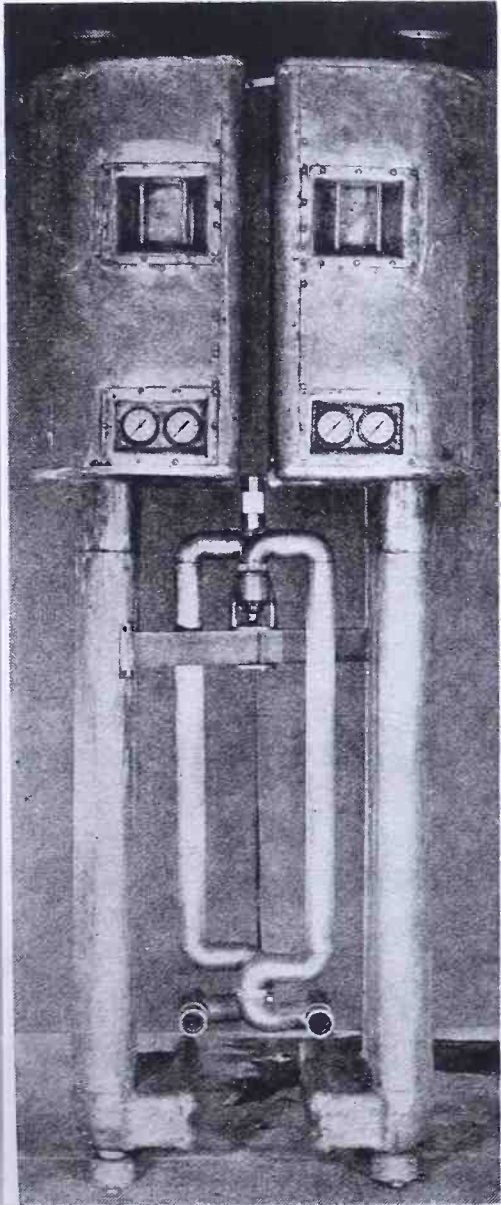

# SPARE PARTS BOXES

Made as per specification—42 B 9 (Int) for shipboard use, Electrical and Mechanical. Navy grey finish. Immediate Delivery.

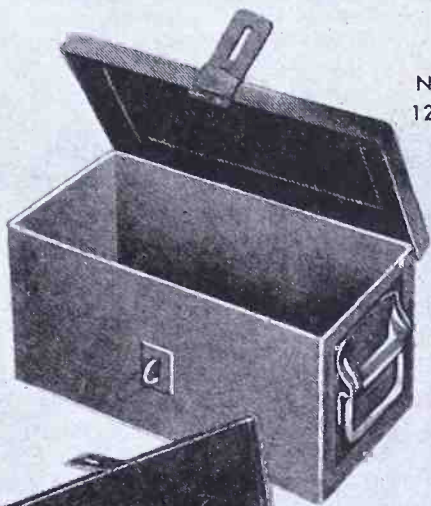

No. 1025-1  
12" x 6" x 6"

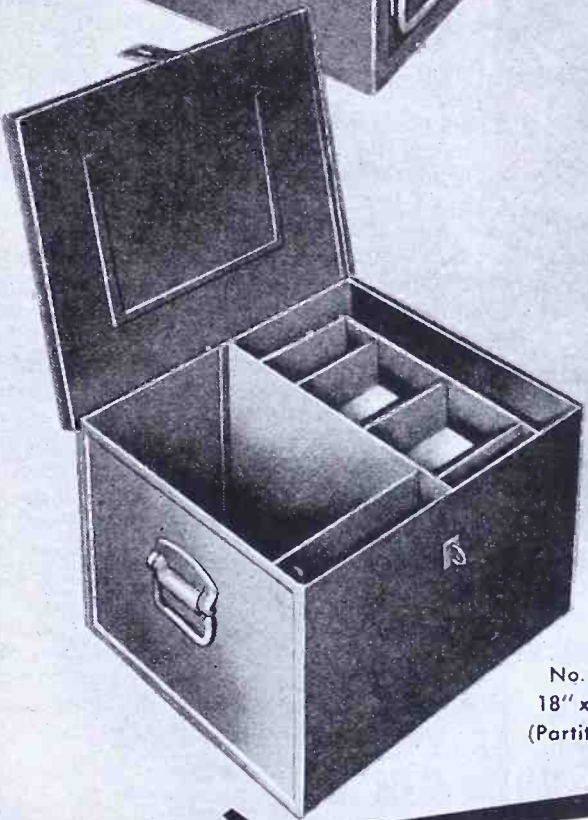

No. 1025-11  
18" x 15" x 12"  
(Partitions extra)

24 STOCK SIZES			
Number	Length	Width	Height
1025-1	12	6	6
1025-2	12	9	6
1025-3	12	12	6
1025-4	12	9	9
1025-5	18	9	6
1025-6	18	9	9
1025-7	18	12	9
1025-8	18	6	6
1025-9	18	15	9
1025-10	18	12	6
1025-11	18	15	12
1025-12	18	12	12
1025-13	18	18	12
1025-15	24	15	12
1025-16	24	15	15
1025-17	24	18	12
1025-18	24	18	15
1025-19	24	18	18
1025-20	24	12	9
1025-23	30	15	9
1025-14	30	15	12
1025-22	36	12	9
1025-21	42	9	9
1025-24	42	12	9

WRITE FOR PRICE LIST

**Cole Steel**  
**office equipment**  
will again be available  
after the war

# COLE

STEEL EQUIPMENT COMPANY  
349 Broadway, New York 13, N. Y. Factory: Brooklyn

# STOP VIBRATION GREMLINS WITH BIRTCHER STAINLESS STEEL - LOCKING TYPE TUBE CLAMPS



Where vibration is a problem, Birtcher Locking TUBE CLAMPS offer a foolproof, practical solution. For ALL types of tubes and similar plug-in components.

**83 VARIATIONS**

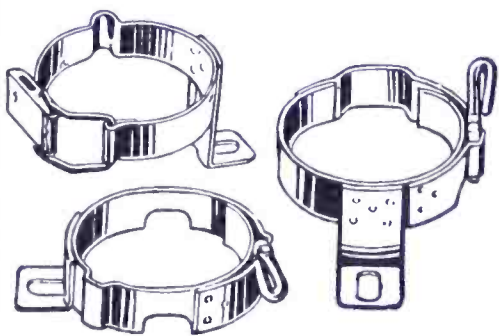

OVER TWO MILLION IN USE  
Send for our standard catalog and samples of corrosion-proof Birtcher Tube Clamps.



**THE BIRTCHER CORPORATION**  
Manufacturers of AIRCRAFT  
and RADIO PARTS  
5087 HUNTINGTON DR. LOS ANGELES 32

(Continued from page 73)

and which is automatically coupled or decoupled, depending on the position of the transmission line shorting bar. Tuning of this coupled circuit is accomplished by vacuum condensers, either at the bottom of the vertical coupling loop, or at the rear of its horizontal portion, depending on frequency. The vertical portion of the coupling loop is so arranged that it can be rotated into a bucking position with respect to the horizontal section, during operation at lower frequencies.

All of the foregoing adjustments for frequency change can be made from the front of the cabinet in a few seconds.

### Low Level Audio and Control Room Equipment

All program material is supplied to the transmitters either by telephone circuits, or by electrical transcriptions. No provisions are made for live pick-ups at the transmitter building. At present the OWI and CIAA programs originate in studios in the East, and are fed through the WLW master control room at Crosley Square in downtown Cincinnati, to the transmitter audio equipment. Figure 14 shows a panoramic view of the equipment bays in the control room. A separate amplifier channel is provided for each modulator input, plus one spare. Each channel is installed in a separate equipment bay.

The incoming lines are terminated in matching networks which provide a means of feeding one to three amplifier channels from any one line. The output of the matching network may be patched directly to the desired amplifier input, or it may be patched through a selector switch, affording a quick means of transfer from one program channel to another. This switch affords a selection of either of two circuits, and is set up by patch cord, so that the selection may be between any two telephone lines, or between telephone line and electrical transcription output.

The signal then is routed to one of four equipment bays which contain the amplifier channels associated with the particular transmitter inputs, and passes through a variable attenuator and an

Figure 14

View of the equipment bays in the control room.

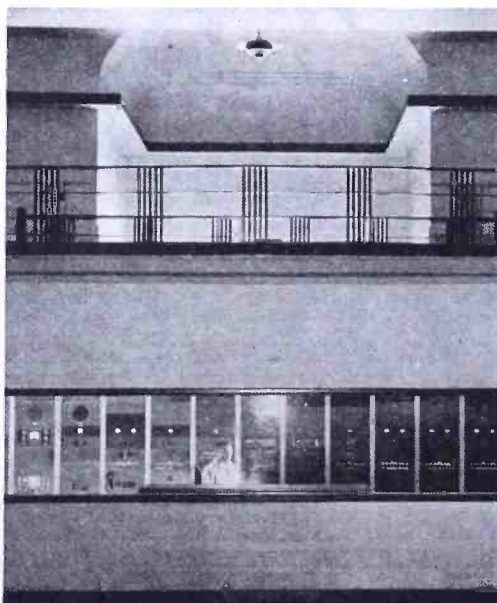

## To Serve You Better

AN ALTERNATE SOURCE  
OF GENUINE BIRTCHER  
TUBE CLAMPS

## Prompt Delivery

We are fully licensed to manufacture the complete BIRTCHER line of locking type, stainless steel tube clamps. Orders placed with us for prompt delivery using BIRTCHER part and identification numbers will be filled at prices as favorable as those to which you are accustomed. All clamps will be identical with those manufactured by the Birtcher Corporation.

SOLE LICENSED MANUFACTURER  
OF BIRTCHER TUBE CLAMPS

**THE GEORGE S. THOMPSON  
CORPORATION**

5240 HUNTINGTON DR.  
LOS ANGELES 32, CALIF.

## University LABORATORIES

**UNIVERSITY  
REFLEX  
SPEAKERS**  
are now the  
**ACCEPTED  
STANDARD  
for all  
WAR USE**

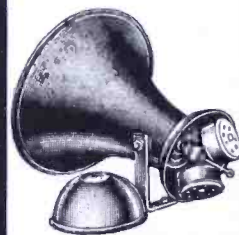

EVERY REFLEX  
in the  
**UNIVERSITY LINE**  
is the result of  
YEARS of  
RESEARCH



EVERY REFLEX  
in the  
**UNIVERSITY LINE**  
has a vital part  
to play in the  
**WAR PROGRAM**



There are  
**OVER 50 SPEAKERS**  
in the  
**UNIVERSITY LINE**

Submit your  
special prob-  
lems direct to  
our engineering  
department.



**UNIVERSITY**  
225 VARICK STREET N. Y. C.

electrical transcription switching relay to the line amplifier. The volume indicator, mounted in the bay, monitors the level at the output of the line amplifier. From this point, the signal passes through a peak clipper, and out of the amplifier bay to the transmitter input attenuator, located on the control desk.

The electrical transcription switching relay mentioned, is controlled by keys on the control desk, as previously described. Monitoring speaker amplifiers and switching equipment are also located in the control room equipment bays. Each program channel has a monitoring take-off at the output of the line amplifier, and this signal is fed through speaker selector switches so arranged that the operator is able to pre-set levels before the signal is fed to the modulator input. The e-t machine output is fed through a pre-amplifier and variable attenuator to the switching relay, and to the selector switches of the monitoring speaker, so that here again the level may be pre-adjusted before the signal is fed to the modulator.

Throughout all of the speech equipment in the control room, complete flexibility is maintained by use of jacks and patch cords, by which any elements, from amplifiers to fixed pads, may be isolated. In most cases, back contacts on the jacks route the signal through its normal channel, but the presence of the jacks in the circuit makes it possible to lift a defective element quickly, and patch in a spare.

#### Modulator

The modulator (Figure 15) consists of a three-stage voltage amplifier, followed by a 2- to 6-tube class B power stage. The first two stages are push-pull 807 and 813 tubes, respectively, and are resistance coupled. These stages are mounted horizontally on a vertical panel in the upper center of the unit, while the circuit components are mounted on the rear. The 813s are resistance coupled to push-pull 891s, located slightly above the main group of tubes, and operating class A as the third voltage amplifier. The 891 stage is coupled with a 1:1 ratio transformer, to 2, 4, or 6 F125 tubes, operating class B with zero-grid current, as the power stage. In the 4 or 6 tube  
(Continued on page 76)

Figure 15

Modulator unit which consists of three-stage voltage amplifier and a two to six-tube class B amplifier.

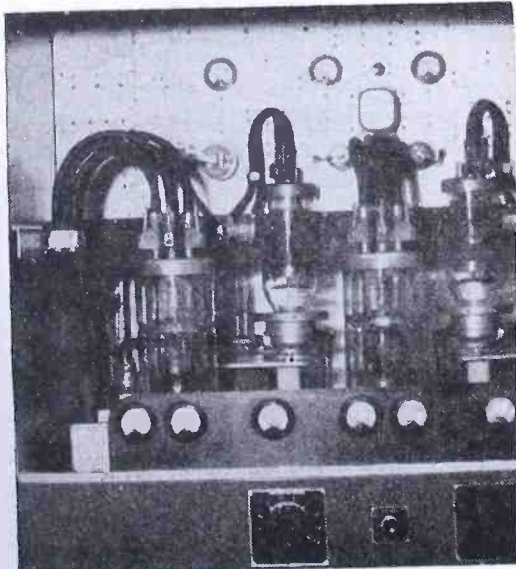

# All to your advantage

**CANNON QUALITY CONTROL** is our investment but you collect the dividends. Let's see how.

We mill all contacts to extremely close tolerances. You get the benefit of low voltage drop. We die cast fittings. You gain strength and save weight. We pioneered the split shell. You (collectively) save hundreds of thousands in the cost of wiring and assembly.

All along the line we take extra care in manufacture. We test, inspect and check again. You have the assurance that, whatever else may fail, the Cannon Plugs you use are dependable.

All that is worth a lot to you isn't it? It's our investment in your good will.

## CANNON ELECTRIC

Cannon Electric Development Co., Los Angeles 31, California

Canadian Factory and Engineering Office:  
Cannon Electric Company, Limited, Toronto

Representatives in principal cities — Consult your local telephone book

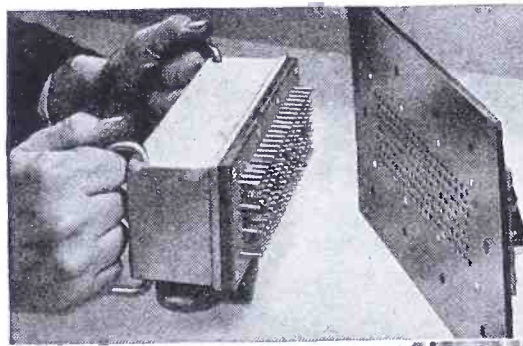

World's largest connector—Cannon  
DPL with 135 contacts.

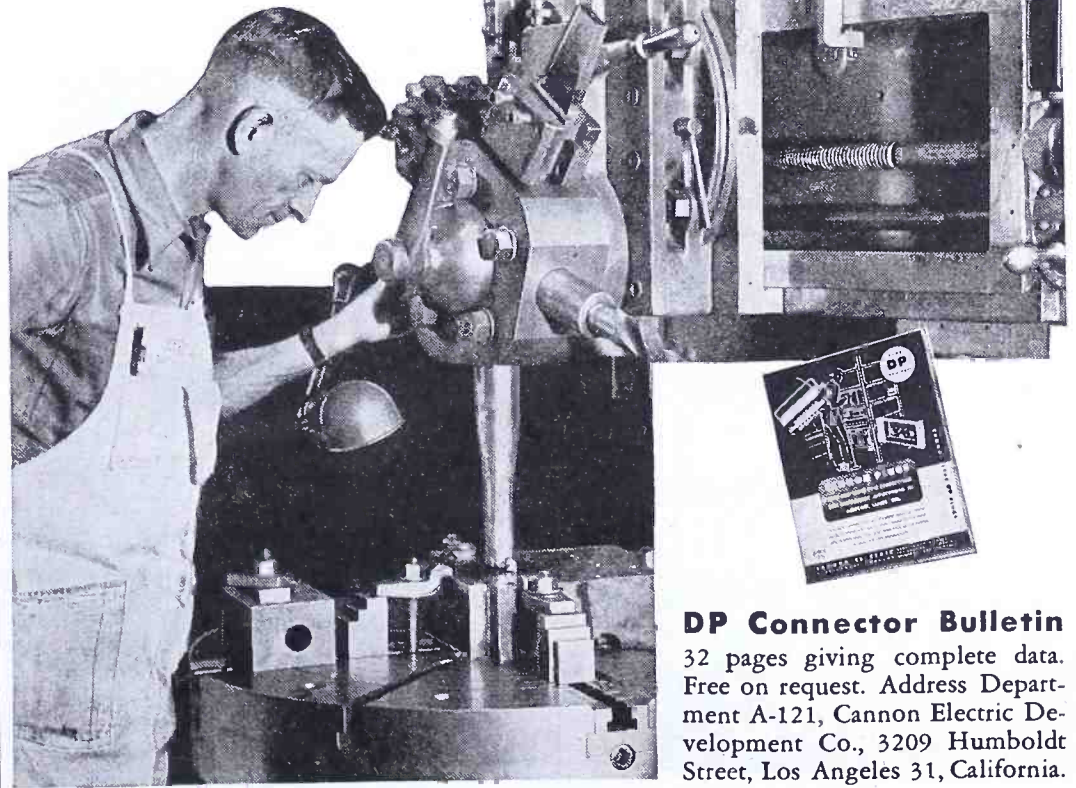

**DP Connector Bulletin**  
32 pages giving complete data.  
Free on request. Address Department A-121, Cannon Electric Development Co., 3209 Humboldt Street, Los Angeles 31, California.

# STANDARD

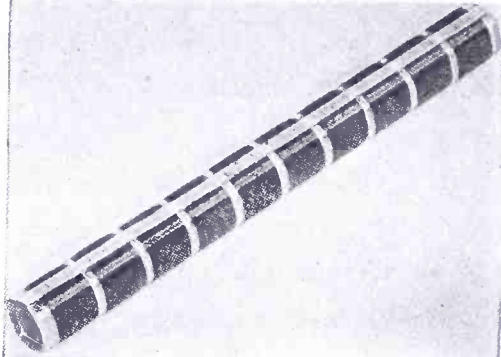

Stick of Relay Coils

## MASTERPIECE

Each unit that we produce bears the unmistakable hallmark of perfection . . . because we specialize — concentrating all our skill in research, engineering and production on the solution of your most trying coil problems. Our engineering staff is available for consultation without obligation.

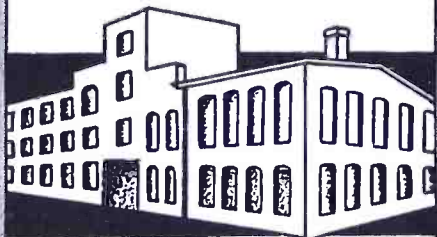

WE INVITE YOUR INQUIRIES

# STANDARD WINDING CO.

44-62 Johnes Street  
NEWBURGH, NEW YORK  
NEW YORK OFFICE: 53 PARK PLACE  
REctor 2-5334

(Continued from page 75)

arrangement, 2 or 3 tubes operate in parallel on each side of the push-pull circuit. Three 125s in the front constitute one side of the class B stage, while three more in the rear constitute the other side.

In order to accommodate tubes of normal differences in characteristics, each tube has individually combined bias and drive adjustment. The circuit is such that these two adjustments are accomplished simultaneously, with one potentiometer in each grid circuit. Each modulator tube plate circuit has a 42-ohm surge limiting resistor in series, which may be seen at bottom of unit in Figure 16.

The modulation transformer, weighing more than 24,000 pounds, and its reactor and d-c blocking condenser, are located in the transformer vault. This combination was designed to cover a frequency range of from 30 to 10,000 cycles, at a power output of 180-kw maximum.

### Power Supply Substation

Power is supplied to the plant from a 33-kv loop circuit, with remote controlled disconnect switches on each side of the take-off point. These switches, both normally closed, may be opened by push-button controls in the transmitter control room, in case of a fault on either line.

At the substation a 3000-kva transformer bank provides 3-phase, 2400-v service, divided into six main circuits to the transmitters, each equipped with fused disconnect switches. Three of these are for the high-voltage plate-supply transformers, and the other three are fed through an induction regulator, and supply a 200-kva, 2400/240-v, 3-phase transformer in each vault. All 240-v power for operating filament transformers, pump and blower motors, low voltage supplies, etc., is obtained from these transformers. Each transmitter becomes an independent unit from the substation to the antenna switching station.

### Transformer Vault

All high voltage transformers, filter reactors, filter condensers, and high-volt-

Figure 16

The 42-ohm surge limiting resistors, which are in series with each modulator plate circuit, at bottom of unit in view below.

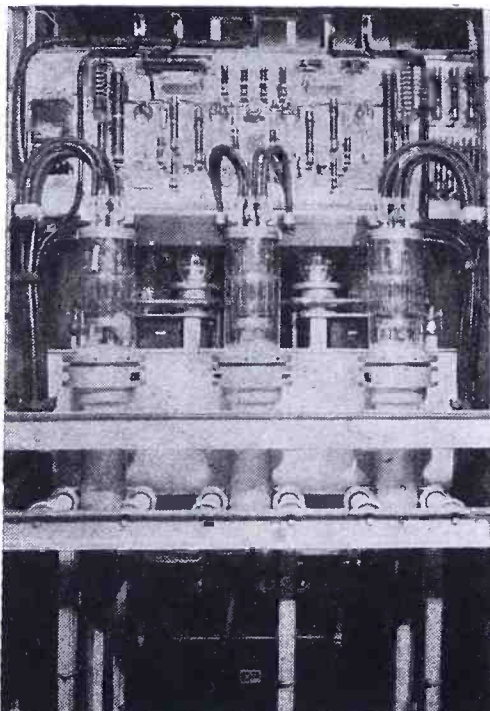

## ADVANCED ENGINEERING

demonstrated by

## THORDARSON

COMPACT, HERMETICALLY-SEALED TRANSFORMER FOR AIRBORNE SERVICE

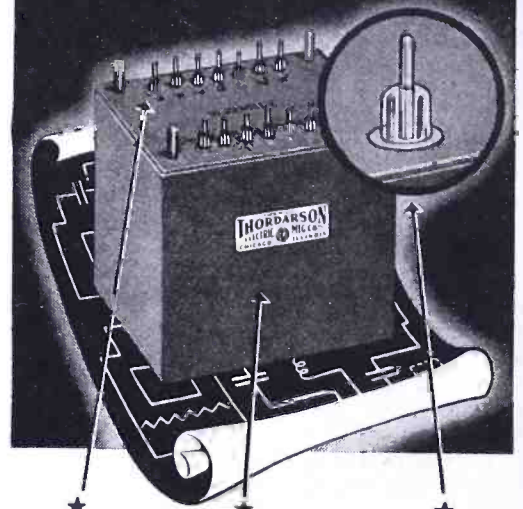

A type of hermetic seal construction to meet the newest rigid requirements of the Armed Forces.

High efficiency in a small package . . . this compact high frequency power transformer 160 to 2600 c.p.s. fills a difficult airborne application.

Since the terminal seal employs metal and glass, absolute protection is assured against all performance difficulties usually caused by climatic changes.



## THORDARSON

TRANSFORMER DIVISION  
THORDARSON ELECTRIC MFG. CO.  
300 WEST HURON STREET, CHICAGO, ILL.

Transformer Specialists Since 1895  
ORIGINATORS OF TRU-FIDELITY AMPLIFIERS

## Wanted ENGINEERS

- Radio
- Chemical
- \* Electrical
- Electronic
- \* Mechanical
- Metallurgical
- \* Factory Planning
- Materials Handling
- Manufacturing Planning

Work in connection with the manufacture of a wide variety of new and advanced types of communications equipment and special electronic products.

Apply (or write), giving full qualifications, to:

R.L.D., EMPLOYMENT DEPT.,  
**Western Electric Co.**  
100 CENTRAL AV., KEARNY, N. J.

\*Also: C. A. L.

Locust St., Haverhill, Mass.

Applicants must comply with WMC regulations

age control components are located in three fireproof vaults within the building, one for each of the three transmitters, built into the bay directly behind each transmitter unit. In the floor plan (Figure 2) the location of the vaults, and the major components of one vault, may be seen.

The high-voltage plate transformer is a 750-kva, three-phase unit, with a special high speed motor-operated tap switch, connected in its secondary winding, which operates under load. The transformer windings and taps are such as to provide variable d-c voltages at the load from 5500 to 15,000-v in 32 steps. Incorporated in the transformer is a voltage regulating control, to operate the tap switch motor, and thus maintain the voltage at any selected value, regardless of input line variations or load on the transformer. Voltage adjustment is accomplished from the transmitter control panel, by means of a rheostat, which is the series calibrating resistor for the contact-making voltmeter in the control unit. The shaft of the rheostat is connected to the panel control through a torque switch, which causes the tap changer to become instantly responsive to adjustments of the control. At all other times, a half-minute time delay is automatically operative, as the tap changer corrects for line voltage fluctuations. The transformer also returns automatically to its lowest voltage tap each time primary voltage is removed for periods in excess of a few seconds in order that reapplication of power may occur at minimum voltage.

The unregulated three-phase power for the high voltage system from the substation is fed through manual disconnect switches in the vaults, and then through series line reactors for limiting fault, or rectifier arc-back currents, through a magnetically operated contactor, and the ignitron interrupter (*see high voltage controls*) before reaching the tap changing transformer. Normally, the magnetic contactor remains closed, and the power interruption is accomplished by the ignitron unit. But if an a-c line overload should occur or a transmitter door should be opened, this contactor operates, following the ignitron interruption, to provide additional protection.

[To Be Concluded in December]

Figure 17  
The rectifier cabinet.

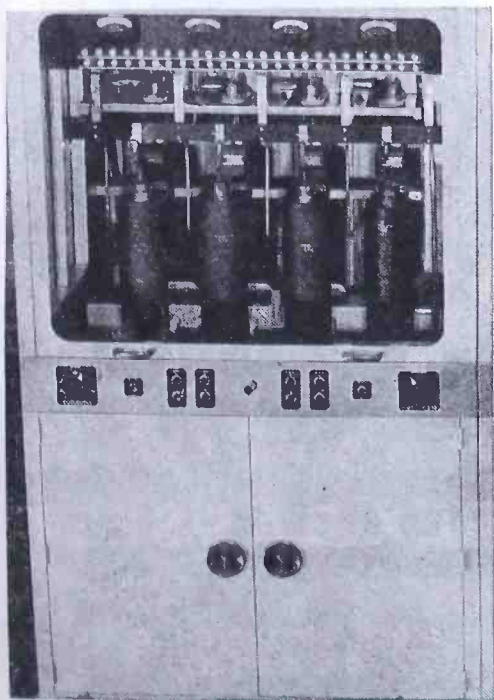

## "Nails" for HITLER'S COFFIN

Milling machine designed and built by Remler for difficult operations requiring precision accuracy.

**THE ENGINEER** who helped design this special machine has a son in the South Pacific, the girl who feeds in the "nails" has a boy friend with General Patton. Like other Americans with a stake in Victory, these Remler workers take a personal interest in improving techniques to lower costs and speed up deliveries.

- For complete sound transmitting systems; radio; plugs and connectors and other electronic components in metal and plastic, consult . . .

REMLER COMPANY, LTD.

2101 Bryant St. • San Francisco, 10, California

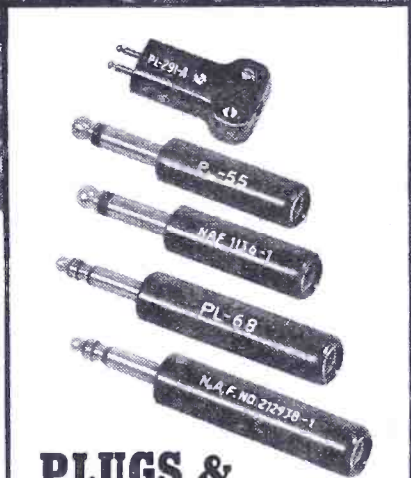

## PLUGS & CONNECTORS

Signal Corps and  
Navy Specifications

Types :		PL		
50-A	61	74	114	150
54	62	76	119	159
55	63	77	120	160
56	64	104	124	291-A
58	65	108	125	354
59	67	109	127	
60	68	112	149	

PLP		PLQ		PLS	
56	65	56	65	56	64
59	67	59	67	59	65
60	74	60	74	60	74
61	76	61	76	61	76
62	77	62	77	62	77
63	104	63	104	63	104
64		64			

NAF  
1136-1 No. 212938-1

Other Designs to Order

# REMLER

SINCE 1918

Announcing & Communication Equipment

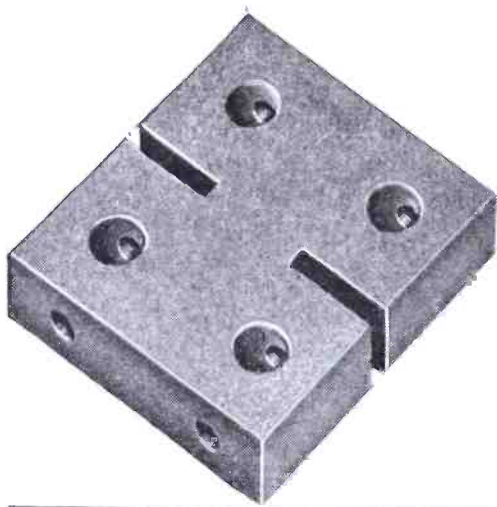

## HAVE YOU INVESTIGATED MYCALEX?

Mycalex has many physical and electrical characteristics which make it outstandingly superior to any other electrical insulation for many purposes. It is particularly effective at ultra-high frequencies.

Mycalex can be sawed, drilled, tapped, ground, polished, turned or milled and dimensions can be held to very close tolerances. It is an ideal material where only a few pieces are required and die cost necessary for other materials would not be justified.

Mycalex is available in sheets, rods, bars, tubes and strips which can be fabricated into almost any shape or size required.

Mycalex is just one trade name for glass-bonded mica insulation also available under several other trade names. Johnson has used and is prepared to furnish any such material.

Johnson as a fabricator is approved and recommended by the manufacturers of this material. Johnson is one of the pioneer fabricators of Mycalex, probably has more complete equipment, and certainly has had more experience than other manufacturers.

Johnson's recommendations will be unbiased. Johnson regularly uses steatite, porcelain, bakelite, hard rubber and all makes of glass bonded mica. If you have an insulation problem, Johnson Engineers will be glad to make recommendations, submit samples or quote prices. Write Johnson today or contact the Johnson Representative in your territory.

**JOHNSON**  
a famous name in Radio

E. F. Johnson Co. Waseca, Minn.

## GOLDMARK ON U-H-F TELEVISION

(Continued from page 44)

rier frequency. It would be difficult to build a receiver and receiving antenna to cover this range and still sell at reasonable price. Now consider the case of a television band providing for thirty 16-mc channels and starting, say, around 450 mc. Such a band would extend from 450 to 950 mc, which is barely more than one octave. As a result the requirements of receiving antennas, of receiver tuning circuits, etc., are considerably simplified and much more easily met. There are indications that the proposed new standards can be fitted into a channel less than 16 mc wide.

"The power requirements for the new u-h-f television transmitters were based on coverage at the present 60-mc channel, and we have not taken into account the appreciable increase in field strength which the higher frequencies offer."

Dr. Goldmark cited that in the report of Dr. R. A. Norton, prepared on behalf of the FCC for the 1940 and 1941 television hearings, propagation data evaluated u-h-f advantages. These data revealed, he said, that, progressing toward the boundaries of the service area, the horizon, field strength from a 5-kw transmitter at 500 mc is approximately equal to that from a 125-kw transmitter at 60 mc.

Analyzing this point, Dr. Goldmark said:

"Simple computation based on Dr. Norton's 1941 report furnished the following interesting data: assuming two transmitters, one operating at 60 mc, the other at 500 mc, both with 1-kw power, and further assuming a transmitting antenna 1000-feet high and receiving antenna 30-foot high, the service area (500  $\mu$ v/m contour) at 60 mc will be 2340 square miles, whereas at 500 mc the coverage increases to 6560 square miles. In contrast to this, the interference area (5  $\mu$ v/m contour) at 60 mc is 25,100 square miles, but is reduced to 19,800 square miles at 500 mc. Stating it differently, the interference to service area ratio at 60 mc is 11 to 1 but only 3 to 1 at 500 mc."

Dr. Goldmark also discussed u-h-f noise conditions. He said that according to a RTPB report the daytime and nighttime atmospheric noise is negligible at 500 mc as well as at 100 mc.

And for any given bandwidth, he pointed out, most man-made noise at 500 mc has a peak amplitude which is only half of that which is present at 100 mc.

The report also reveals that the ratio of the peak amplitude of man-made noise in a receiver having a 16-mc bandwidth to that of man-made noise in a 6-mc receiver is 1.9 to 1. Assuming an urban location, the peak noise amplitude will therefore be  $(\frac{1}{2} \times 1.9) = .8$  times as great in the 16-mc u-h-f receivers as in a 6-mc receiver operating in the v-h-f spectrum, explained Dr. Goldmark.

The annoying receiver hiss, which would introduce a salt and pepper effect in the presence of a weak signal, is proportional to the square root of the bandwidth only. Thus, he said, noise due to receiver hiss would be only 1.6 times as intense in a 16-mc receiver as in a 6-mc receiver; a negligible amount with respect to the 500 microvolt-per-meter contour.

Highly-directional receiving antennas will not respond to all the noise-energy perceptible at a given receiver location,



Available from local dealers or by writing factory direct.

## UNIVERSAL STROBOSCOPE

This handy phonograph turntable speed indicator, complete with instructive folder, is now available gratis to all phonograph and recorder owners through their local dealers and jobbers. As a recorder aid the Universal Stroboscope will assist in maintaining pre-war quality of recording and reproducing equipment in true pitch and tempo.

Universal Microphone Co., pioneer manufacturers of microphones and home recording components as well as Professional Recording Studio Equipment, takes this means of rendering a service to the owners of phonograph and recording equipment. After victory is ours—dealer shelves will again stock the many new Universal recording components you have been waiting for.



AVIATION COMMUNICATION EQUIPMENT

**RB**

QUARTZ RADIO CRYSTALS

**ELECTRONIC EQUIPMENT**

**QUARTZ CRYSTALS**

**MANUFACTURING**

**ENGINEERING**

**DESIGNING**

**TO ORDER**

**REX BASSETT**

INCORPORATED

FORT LAUDERDALE  
FLORIDA



said Dr. Gammack. He pointed out that normally, noise can be assumed to come from all directions at once, that the net received amount will pervade only that part of the noise which originates within its beam. At 500 mc, the explanation of the improvement in the signal-to-noise ratio will easily amount to 8 or 8 db or more, as compared with that which is obtained with the customary double dipole array around 100 mc.

Therefore, he said, the increase in signal-to-noise ratio coupled with the predicted increase in field strength in effect would cause a 5-hp transmitter operating at 500 mc to provide a service comparable to that of 100-hp transmitters operating at 100 mc.

**G. L. Beers Explains**

**ANSWERING** questions relating to stability of transmitters and receivers, color television and channel assignments, G. L. Beers, staff assistant to the chief engineer of RCA Victor division, RCA, said that in general it can be stated that the stability of television transmitters for frequencies of 50 mc, 100 mc, and 500-1000 mc will probably be a definite percentage of the carrier frequency. He explained that it is believed that a transmitter stability of .05% can be achieved throughout this entire frequency range unless some new technique for the generation of power in the region of 500-1000 mc is required. This would impose lower limits on frequency stability. He said that the minimum drift which can be achieved with arrangements which are suitable for broadcast receivers will result in a percentage drift which remains substantially constant throughout the frequency range considered. According to Mr. Beers the best frequency stability which can probably be obtained in a commercial product would be approximately .05%.

Analyzing this problem further, Mr. Beers said: "The primary effect of transmitter instability and receiver drift upon a 6-mc television channel for frequencies in the region between 50 mc and 100 mc is to limit the deviation which can be used for a 200-ke frequency modulation television sound channel. The RTPB committee which considered this subject adopted a maximum deviation of plus or minus 25 kc.

"It is our belief that the effect of transmitter and receiver instability for 6-mc channels at frequencies up to 100 mc will not impose material limitations on the resolution which can be obtained from television receivers. No frequency stability difficulty is anticipated with a 20-mc channel at 300 mc. The frequency stability which can be obtained in the region between 500 and 1000 mc will not permit the use of a 200-ke television sound channel. The channel width required for the transmission of the sound at carrier frequencies in this region must either be increased materially or some other method of sound transmission must be employed. Frequency stability limitations from the standpoint of both picture and sound will not permit the use of 6-mc channels at 1000 mc. It is believed that the benefits which can be realized from automatic frequency control in re-

(Continued on page 80)

**PORTABLE POWER PROBLEMS**

THIS MODEL B - (6-4)

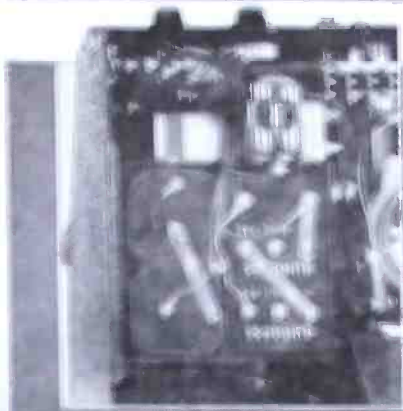

**HIGH SENSITIVITY** and standardized operation characterize the General Electric Model "B" Electrocardiograph which assists doctors in quickly establishing accurate diagnosis and prognosis of heart conditions. A true photographic record of minute change in heart potential waves is given by this remarkable lightweight, battery-powered instrument. As a result, it quickly and economically makes available information that would otherwise be very difficult to obtain.



**BATTERY COMPARTMENT**, shown upper left, houses the power source for the Model "B" Electrocardiograph (Burgess "A" and "B" Batteries). General Electric descriptive literature emphasizes that "the power source is a dependable source of power—always smooth." Battery power is independent of commercial electric supply. Burgess engineers special-purpose batteries for specific commercial and laboratory applications. **Solve your portable power problems. Send coupon for literature.**



**FREE . . . 20-PAGE BROCHURE** containing 21 descriptive pages, 25 charts and graphs, and descriptive literature for electronic applications. Write Dept. 9 for your free copy. Burgess Electronics Division, General Electric Co., Schenectady, N. Y.

Name   
 Company   
 Address   
 City

**BURGESS B**

COMMUNICATIONS

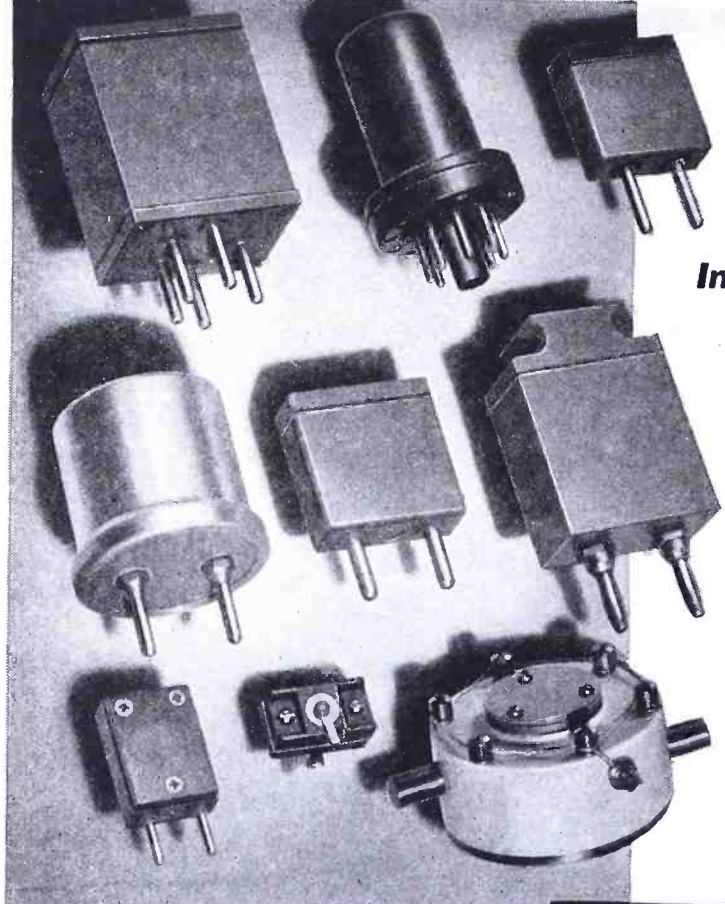

**In QUARTZ  
CRYSTALS**  
*the most significant  
advancements have  
been introduced by*  
**BLILEY**

Do more than before . . .  
buy extra War Bonds



**BLILEY ELECTRIC COMPANY** • UNION STATION BUILDING • ERIE, PENNSYLVANIA

**MEASUREMENTS AROUND THE WORLD**

0.25-INCH, DESIGNATED BY THE WORD  
"JAOB"

IS CONSIDERED A PRETTY FINE  
DEGREE OF MEASUREMENT IN INDIA

—but in America . . . in fact, wherever delicate and  
precise measurements are vital in Radio and  
Electronic devices, there you will find

**MONARCH**

MEASURING—TESTING—CALIBRATING Equipment,  
performing in a manner that has made Monarch

Universally accepted for  
dependable performance



Our Post-War  
Plans are well Advanced

**MONARCH MFG. CO.**

**2014 N. Major Ave. Chicago, Ill.**

(Continued from page 79)

ceivers designed for the television frequencies under consideration do not justify the additional circuit complications and the resultant increase in costs to the customer."

Fidelity standards were also discussed by Mr. Beers. He said that the subject of the adequacy of a 60-mc channel in the frequency region between 50 and 300 mc was considered by committee 1 of RTPB panel 6. He offered a resolution adopted by the committee, which, he said, expressed his opinion on this subject. The resolution read:

"It is the opinion of the committee that the present television bandwidth of 6 megacycles renders an adequate monochrome television service having acceptable entertainment value. An increase in the bandwidth would not add to the value of picture commensurate with efficient spectrum utilization in the existing bands below about 200 megacycles. A reduction in bandwidth would not provide gains in the form of possibilities for increase in number of channels or more economical use of the space available, commensurate with the resulting degradation of the picture."

Mr. Beers pointed out that practical television receivers which will select any one of 20 to 30 six-mc channels in the 50-300 mc band can be constructed.

**SPECIAL C-R TUBES**

(Continued from page 48)

tion screen. While a perfectly diffusing reflective screen is the most satisfactory from the standpoint of viewing angle, it is considerably less efficient than a screen having directive characteristics. However, the greatest efficiency is obtained by using a translucent screen, but again the viewing angle becomes a limiting factor.

Another problem of considerable interest is the development of tubes and methods for the transmission and reception of colored pictures. Considerable work has been done along this line by Dr. Goldmark of CBS in which mechanically operated color filters are used. This system requires direct-viewing picture tubes which must be operated at a light output considerably above that of the presently used direct viewing tubes for black and white. This brings up the problem of tube life which may be materially shortened at higher intensities, as well as picture size which again depends upon tube-face diameter.

Several other methods for producing colored pictures have been suggested. Latest among these is the Baird tube employing a three-color fluorescent screen which is excited by three separate cathode-ray guns all assembled in the same envelope. The elimination of mechanical color filters as well as light losses due to them would be in favor of such a tube design. However, such a tube could present some rather serious manufacturing problems which

might make its cost prohibitive. At the same time there would be a definite limitation to picture size since the envelope diameter must be considerably greater in diameter than the fluorescent screen.

During the past three years many new applications for cathode-ray tubes have been found in the prosecution of the war. Various types of screens have been developed including high speed, dark trace, long persistence, and photo-emissive types used for detection and combat purposes, which can only be mentioned here, but which will have many and varied postwar applications.

Looking toward postwar applications of c-r tubes and possible markets, the uses might be classified as television, aviation, industrial, radio servicing, laboratory and medical applications in the order of their importance.

By far the most important of the above markets will be television.

Television has, as a possible market, every home in our larger cities, with direct viewing and limited projection type tubes for immediate postwar use.

## CAA COURSE SOLUTIONS

(Continued from page 40)

Use of the graphical method as described below and illustrated in Figure 4:

A construction line is drawn perpendicular to the goniometer line from the intersection point  $O$ . The distance from the center to where this line crosses the goniometer line or its extension, to the same scale as used for vectors  $V$ , is the value of  $L_0$  and is always positive. Angle  $A$  is the angle between the negative portion of the goniometer line and the closer adjacent course. (That part of the goniometer line on the opposite side of the center from the vector  $L_0$  is referred to as the negative portion of the goniometer line.

[To Be Concluded In December]



# 3 RECEIVERS . . . . . COVER AERONAUTICAL TELEPHONE FREQUENCIES

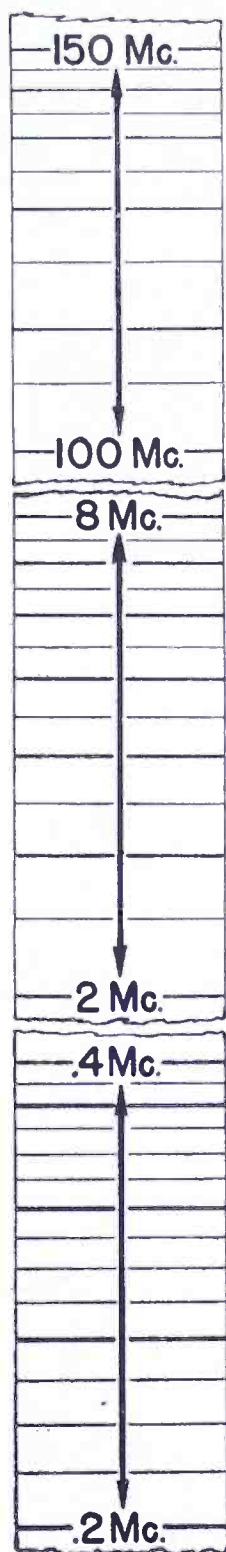

**Comco Model 132 VHF Receiver**

Comco Model 132 VHF Receiver—fixed frequency, crystal controlled—frequency range 100 to 150 Mc.—single channel—superheterodyne.

**FEATURES:** High "Q" lines used for antenna and front-end inductances. Three IF stages. Amplified AVC. AVC-operated squelch circuit. Noise limiter. Twelve tubes. Standard 5¼-inch rack panel mounting.



**Comco Model 82-F Medium Frequency Receiver**

Comco Model 82-F Medium Frequency Receiver. Fixed frequency—crystal controlled—frequency range 2 to 8 Mc. Single channel—superheterodyne.

**FEATURES:** Three high "Q" circuits prior to mixer—one RF stage—one IF stage—total seven tuned circuits—antenna and second detector—amplified AVC—AVC-operated squelch circuit—eight tubes—rack-mounted on standard 3½-inch by 19-inch panel.



**Comco Model 126 Low Frequency Monitoring Receiver**

Comco Model 126 frequency monitoring receiver. Fixed tuned T-R-F type—frequency range 200 to 400 Kc—two R-F stages—detector—output—five tubes—especially designed for monitoring CAA range transmissions and weather broadcasts. 278 Kc. control tower, etc. Complete receiver—rack-mounted on standard 3½-inch by 19-inch panel.

THESE Comco receivers are especially designed for airport traffic control towers, aeronautical ground stations or point-to-point services. Suitable for local or unattended remote operation. These receivers furnish speaker output for local operation. Self-contained power supply for 110 volts AC operation. Designed for ease of installation and maintenance. Developed through practical operating experience and recommendations of leading airlines. Extremely low maintenance required. Now being supplied to our armed forces for similar service in military installations.

## COMMUNICATIONS COMPANY, Inc.

*Manufacturers of Radio and Electronic Equipment*

CORAL GABLES  34, FLORIDA

# Q METER

## MODEL 160-A

*Direct Reading*

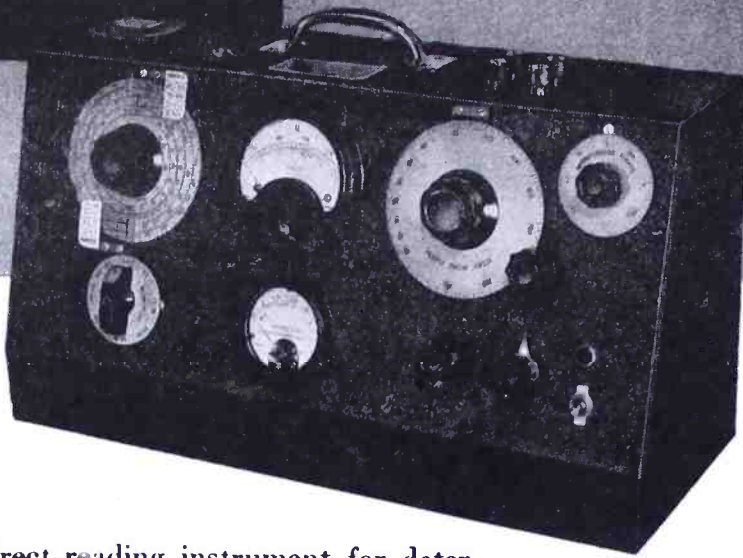

A dependable direct-reading instrument for determining the Q or the ratio of reactance to resistance, of coils. Used in design and production engineering of Radio and Electronic equipment. Condensers and other components readily measurable.

*Determines effective inductance or capacitance*



### BOONTON RADIO

BOONTON, N. J.

*Corporation*



DESIGNERS AND MANUFACTURERS OF THE "Q" METER . . . QX-CHECKER . . . FREQUENCY MODULATED SIGNAL GENERATOR . . . BEAT FREQUENCY GENERATOR . . . AND OTHER DIRECT READING TEST INSTRUMENTS

## SMART IDEA:

Though we're all absorbed in vital war work, let's give some thought to the future. Do a smart thing now — get thoroughly acquainted with

Insuline's vast line of Radio-Electronic Products and the Insuline Manufacturing Facilities . . .

*These 2 books tell the story. Write for them now.*

48-page Catalogue describes Insuline's vast line of Radio-Electronic Products.

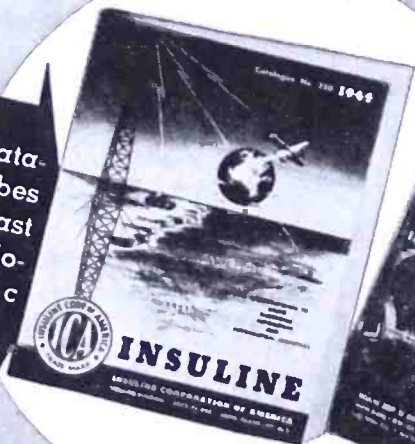

8-page Brochure presents Insuline's organization and manufacturing facilities.

What are your requirements? Send data for immediate assistance.



# INSULINE

CORPORATION OF AMERICA

INSULINE BUILDING • LONG ISLAND CITY, N.Y.



### FIRST ANNUAL CONFERENCE

### TELEVISION BROADCASTERS ASSOCIATION, INC.

Hotel Commodore, New York City  
December 11 and 12, 1944

**Monday, December 11, 1944**

10:00 A. M. Opening remarks: *Dr. Allen B. Du Mont, TBA president* Report on arrangements; *O. B. Hanson, vice-president, NBC, chairman of conference*

"New Horizons in Television": *Dr. W. R. G. Baker, vice president in charge of electronics, G. E. and E. W. Engstrom, in charge of the RCA Laboratories.*

"Television Programming": *John F. Royal, vice president in charge of television of NBC; Robert L. Gibson, assistant to vice president in charge of advertising and publicity at G.E., and Thomas H. Hutchinson, in charge of production for RKO Television Corporation.*

"Establishing Television Networks": *Harold S. Osborne, chief engineer of A. T. & T.*

12:30 P. M. Luncheon session.

"Television and the Broadcaster"; *Lewis Allen Weiss, Don Lee Network.*

2:00 P. M. Panel meetings, *Dorman D. Israel, presiding.*

Panel meetings will be conducted by: *C. A. Priest, G.E. (manufacturers); Samuel H. Cuff, DuMont (broadcasters); Thomas H. Hutchinson, RKO Television (program producers); William H. Weintraub (advertising agencies); Clifford Denton, New York Daily News (newspapers); Paul Larsen, SMPE (theatres and motion pictures); and William Morris (talent).*

Topics:

- "Broadcast Television Licenses"
- "Television and the Theatre"
- "Program Production and Advertising Agencies"
- "Television Receiver Manufacture"
- "Television Transmitters."

7:30 P. M. Banquet. \* "Seeing Our Neighbors." Large screen television demonstration with special telecast to ballroom.

**Tuesday, December 12, 1944**

9:30 A.M. \* "What I See in Television"

10:30 A. M. Round-table discussions: *Dr. Alfred N. Goldsmith, chairman.* Experts who will handle question and answer session, will include *O. B. Hanson, NBC; Allen B. DuMont, president of TBA; Dr. C. F. Jolliffe, RCA; F. J. Bingley, Philco; J. E. Keister, G.E.; Harry Lubcke, Don Lee; Jack R. Poppele, WOR; A. H. Brolly, Balaban and Katz; and Klaus Landsberg, Television Productions, Inc.*

12:30 P. M. Luncheon session. \*\* "The Motion Picture and Television."

3:30 P. M. to 8:00 P. M. Visits to N. Y. City television stations.

\*Speakers to be announced.

# NEWS BRIEFS

## 2-WAY EQUIPMENT STILL ON PRIORITY, SAYS WPB

WPB has announced that there has been no relaxation of restrictions that would allow the sale of two-way equipment on unrated purchase orders. Certain manufacturers who have erroneously informed their customers that they could make deliveries on unrated orders have been asked to correct this impression.

Two-way emergency radio communication equipment is available only in limited quantities for essential use by police departments, public utilities, railroads and other essential industries when the equipment is vital to their operation, WPB said.

\* \* \*

## F. E. WALTERS GOES TO MECK INDUSTRIES

Fred E. Walters has been appointed plant manager of the John Meck Industries, Plymouth, Indiana. Mr. Walters was formerly with International Detrola Corporation as production manager.



\* \* \*

## ILLINOIS U. NAMES EVERITT E. E. DEPT. HEAD

Dr. W. L. Everitt has been named professor and head of the department of electrical engineering at the University of Illinois.

Dr. Everitt will take up his duties at the University immediately on release from war service, in Washington.

Dr. Everitt succeeds Ellery B. Paine, whose retirement was announced recently.

\* \* \*

## A. J. HALL NOW U. M. C. RESEARCH ENGINEER

A. J. Hall has been appointed production and research engineer for the Universal Microphone Co., Inglewood, Cal.

He was formerly with the Kellogg Switchboard and Supply Co., Chicago, as engineer in charge of design, research and development laboratories.



\* \* \*

## NBC AND COLUMBIA UNIVERSITY SPONSOR TELEVISION COURSE

The first television course to be recognized for credit toward a university degree was inaugurated recently by the University Extension of Columbia University in cooperation with the NBC University of the Air.

Forty persons are enrolled in this 15-week course, representing one-tenth of the total applications for admission.

Twenty guest experts in various fields of television are expected to address the class during the 15 weekly sessions.

\* \* \*

## KOBAK BECOMES MBS PRESIDENT

Edgar Kobak has been elected president of the Mutual Broadcasting System. He suc-

(Continued on page 89)

*The Complete Line*

**OF RECTIFIERS AND PHOTOTUBES**

**CETRON**



Particularly sensitive to blue and violet light. RMA spectral sensitivity designation S-4. 5-Pin base interchangeable with other similar tubes.

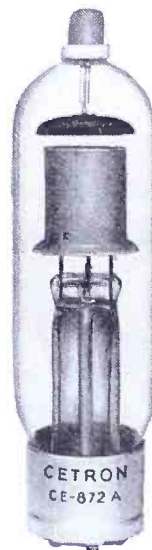

Rectifier designed to meet rigid Army and Navy specifications. Incorporates numerous improvements insuring efficiency, ruggedness and long-life.



Grid control Rectifier (Thyratron) especially suited for industrial use, such as handling primary currents of small resistance welders—motor control, etc.

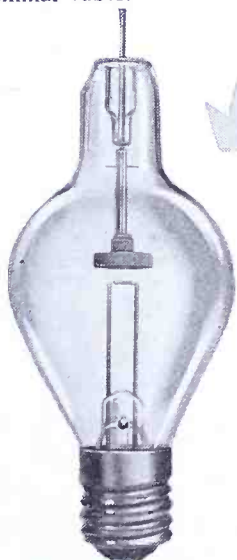

CE-235 is a half wave Argon-filled Rectifier with screw base, sturdily constructed for long, dependable service.

Cetron Rectifiers are available in gas and mercury filled, both full, and half wave types in a wide range of ratings.

Cetron Phototubes are produced by us to take care of almost every situation . . . over 50 types, both blue and red sensitivity.

Continental's long experience and careful production methods insure you the utmost in satisfaction from all the many types of tubes we make. Write for complete catalog.



**CONTINENTAL**

**ELECTRIC COMPANY GENEVA, ILL.**

★ CHICAGO OFFICE, 903 Merchandise Mart  
NEW YORK OFFICE, 265 West 14th Street

# QUARTER-WAVELENGTH INSULATORS

(Continued from page 54)

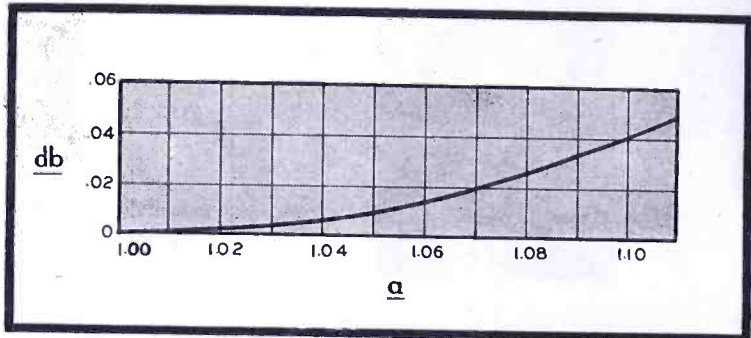
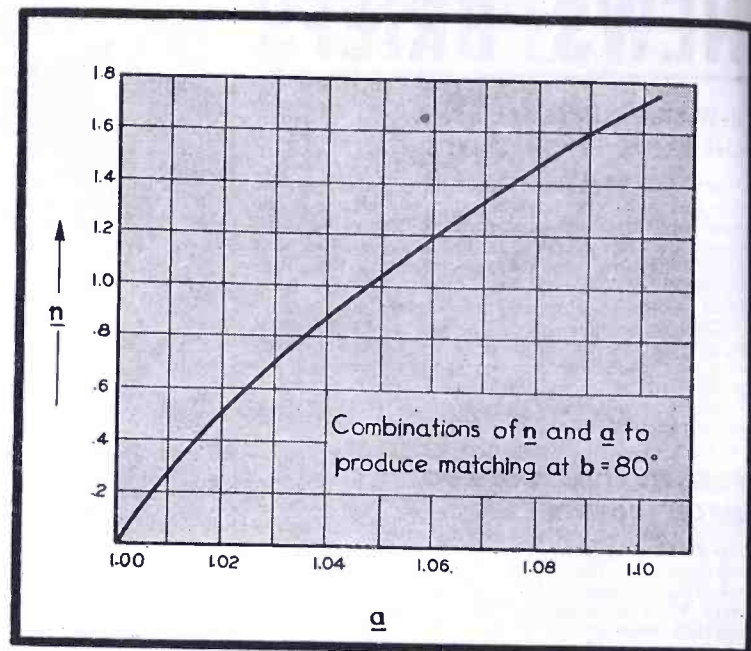
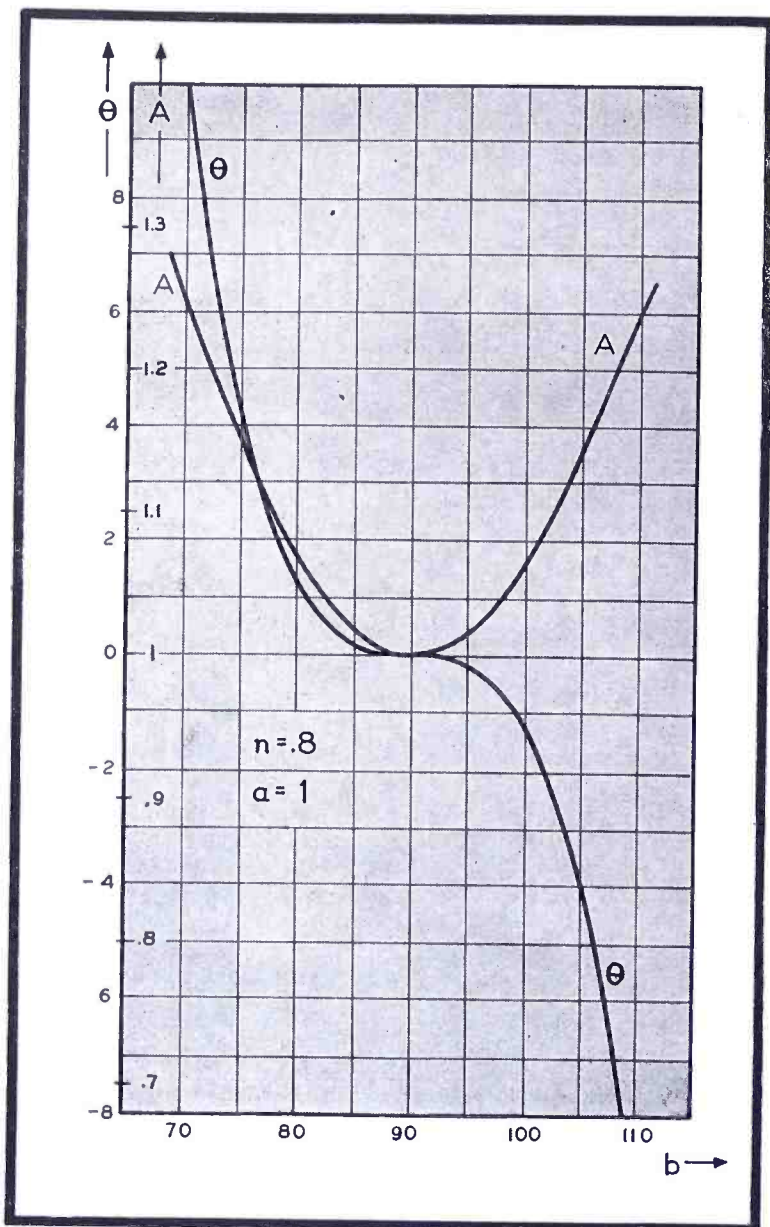

Figures 5 (left), 6 (top, right) and 7 (above, right) Figure 5,  $A$  and  $\theta$  for a double-stub support with  $a = 1.0$  and  $n = 0.8$ . Figure 6, relation of  $n$  and  $a$  to produce matching at  $b = 80^\circ$  and  $100^\circ$ . Figure 7, loss at  $b = 90^\circ$  as a function of  $a$ .

tain perfect matching. This is easily seen to be the following equation  

$$\tan^2 b = a^2 \tan^2 b - n^2 - 2an$$
 (9)  
 or solved for  $n$ , it becomes

$$n = a \left[ \sqrt{1 + \frac{a^2 - 1}{a^2} \tan^2 b} - 1 \right] \quad (10)$$

Equation 10 thus gives combinations

of values of  $a$  and  $n$  which will produce zero loss at given values of  $b$ . Using  $b = 80^\circ$  and  $100^\circ$  as points at which we wish to have zero loss a curve relating  $n$  to  $a$  is plotted in Figure 6. This gives pairs of values which may be used to obtain perfect matching at  $80^\circ$  and  $100^\circ$ . Again re-

(Continued on page 86)

## JONES 500 SERIES PLUGS AND SOCKETS

Designed for 5,000 volts and 25 amperes. All sizes polarized to prevent incorrect connections, no matter how many sizes used on a single installation. Fulfill every electrical and mechanical requirement. Easy to wire and instantly accessible for inspection. Sizes: 2, 4, 6, 8, 10, and 12 contacts. Send for a copy of Bulletin 500 for complete information. Write today.

**HOWARD B. JONES CO.**  
 2460 W. GEORGE STREET  
 CHICAGO 18, ILL.

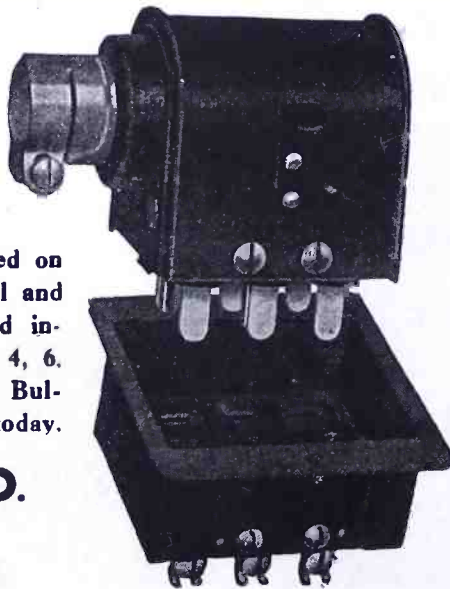

### STATEMENT OF THE OWNERSHIP, MANAGEMENT, CIRCULATION, ETC., REQUIRED BY THE ACTS OF CONGRESS OF AUGUST 24, 1912, AND MARCH 3, 1933, OF COMMUNICATIONS

Published monthly at New York, N. Y., for October 1, 1944.

State of New York }  
 County of New York } ss.:

Before me, a Notary Public, in and for the State and county aforesaid, personally appeared B. S. Davis, who, having been duly sworn according to law, deposes and says that he is the Business Manager of COMMUNICATIONS, and that the following is, to the best of his knowledge and belief, a true statement of the ownership, management, etc., of the aforesaid publication for the date shown in the above caption, required by the Act of August 24, 1912, as amended by the Act of March 3, 1933, embodied in section 537, Postal Laws and Regulations, to wit: 1. That the names and addresses of the publisher, editor, managing editor, and business manager are: Publisher, Bryan Davis Publishing Co., Inc., 19 East 47th Street, New York, N. Y.; Editor, Lewis Winner, New York, N. Y.; Managing Editor, None. Business Manager, B. S. Davis, Ghent, N. Y.; 2. That the owners are: Bryan Davis Publishing Co., Inc., 19 E. 47th St., New York 17, N. Y.; B. S. Davis, Ghent, N. Y.; J. C. Munn, Union City, Pa.; A. B. Goodenough, Port Chester, N. Y.; P. S. Weil, Great Neck, N. Y.; F. Walen, Union City, N. J.; G. Weil, Great Neck, N. Y.; L. Winner, New York, N. Y. 3. That the known bondholders, mortgagees, and other security holders owning or holding 1 per cent or more of total amount of bonds, mortgages, or other securities, are: None. 4. That the two paragraphs next above, giving the names of the owners, stockholders and security holders, if any, contain not only the list of stockholders and security holders as they appear upon the books of the company, but also, in cases where the stockholder or security holder appears upon the books of the company as trustee or in any other fiduciary relation, the name of the person or corporation for whom such trustee is acting, is given; also that the said two paragraphs contain statements embracing affiant's full knowledge and belief as to the circumstances and conditions under which stockholders and security holders who do not appear upon the books of the company as trustees, hold stock, and securities in a capacity other than that of a bona fide owner; and this affiant has no reason to believe that any other person, association, or corporation has any interest direct or indirect in the said stock, bonds, or other securities than as so stated by him.

(Signed) B. S. DAVIS, Business Manager.  
 Sworn to and subscribed before me, this 19th day of September, 1944.  
 (Seal) FRANKLIN B. GOOLD, Notary Public.  
 Commission expires March, 1946.

# "DIE-LESS" DUPLICATING

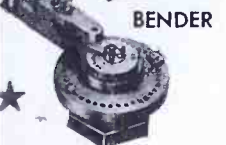
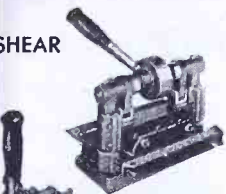

DI-ACRO is pronounced "DIE-ACK-RO"

**No Dies!** "DIE-LESS" DUPLICATING might be described as a new industrial technique made possible by the accuracy, extreme adaptability and ease of operation of DI-ACRO Precision Machines—Shears, Brakes, Benders—especially when used as a continuous, integrated production process. Parts can be made just as accurately as with dies, to tolerance of .001".



Write for catalog "DIE-LESS" DUPLICATING



**O'NEIL-IRWIN MFG. CO.**

322 FIFTH AVENUE SOUTH • MINNEAPOLIS 15, MINNESOTA

Continuously Since 1930



AIRCRAFT MARINE • BROADCAST POLICE • COMMERCIAL • AMATEUR

## HIPOWER CRYSTAL COMPANY

Sales Division—205 W. Wacker Drive, Chicago 6  
Factory—2033 Charleston St., Chicago 47, Ill.

## Filters and Transformers

...for Unusual Jobs

Our new Catalog covering the specialized line of ADC Transformers, Filters, Equalizers, Key Switches, Jacks, Plugs and other electronic components is now ready.



Write for ADC Catalog No. 14.

*Audio Development Co.*

2833 13th Ave. S., Minneapolis, Minn.

# Radio AND ELECTRONIC DEVICES



## BURSTEIN-APPLEBEE CO.

1012-1014 McGee St. • Kansas City 6, Missouri

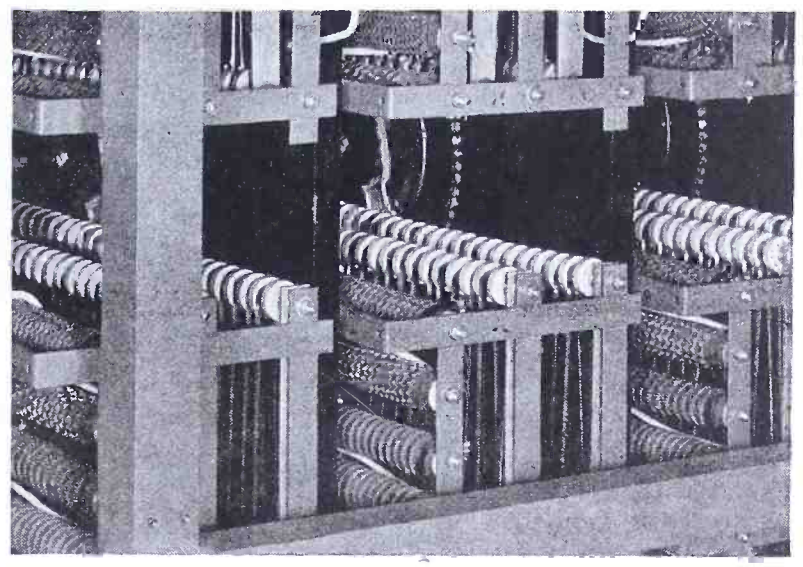

## ADAPTABLE and DEPENDABLE RESISTORS

**A**DAPTABILITY and dependability of resistors assume primary importance in the assembly of large rheostat control units. The wide range of resistance values and capacities that can be built up from the Ward Leonard line is limitless. The many types and mounting arrangements permit the meeting of load requirements in minimum space. It is obvious in an assembly as shown above that the dependability of the individual resistor is an absolute essential.

For over fifty years industry has looked to Ward Leonard for both resistors and resistor assemblies. This experience has given Ward Leonard Engineers the viewpoint of user and designer. It is reflected in the completeness of the Ward Leonard line of Resistors.

Whatever your requirements you will find a Ward Leonard Resistor that exactly meets your conditions. Send for Bulletins.

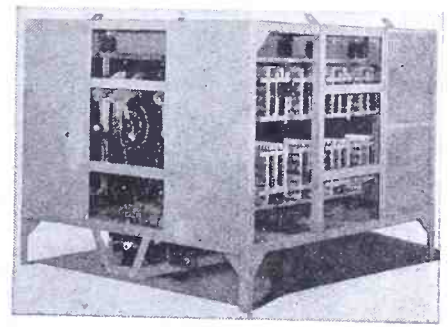

This motor operated Ward Leonard assembled rheostat is built up from several types of Ward Leonard Resistors.



# WARD LEONARD RELAYS • RESISTORS • RHEOSTATS

Electric control  devices since 1892.

WARD LEONARD ELECTRIC COMPANY  
75 SOUTH STREET, MOUNT VERNON, N. Y.

# INSULATORS

(Continued from page 84)

ferring to equation 5 it is seen that at  $b = 90^\circ$

$$\frac{Z_s}{Z_0} = \frac{1}{a^2} \quad (11)$$

which means, of course, that if  $a$  is not equal to unity there will be a mismatch at the midfrequency and a consequent loss. From equation 8 it is seen that at  $b = 90^\circ$  the angle of  $Z_s/Z_0$  is zero. Thus by selecting appropriate values of  $a$  the loss at  $b = 90^\circ$  can be set arbitrarily within certain practical limits. A curve relating the db loss at  $b = 90^\circ$  to values of  $a$  is presented in Figure 7. If it be required that the loss at the mid-frequency not exceed 0.005 db,  $a$  is seen to be about 1.035 and from Figure 6 the corresponding value of  $n$  is seen to be 0.8.

Before any calculations are made, then, one may expect an attenuation curve showing about 0.005 db loss at  $b = 90^\circ$ , decreasing to zero at  $b = 80^\circ$  and  $100^\circ$  and then, as distance from the midfrequency increases, a loss which increases again to values above the allowable amount. The frequency range in this case over which the attenuation is equal to or less than 0.005 db will be wider than for the case where  $a = 1.00$ .

Curves for  $A$  and  $\theta$  for the case of  $a = 1.035$  and  $n = 0.8$  are plotted in Figure 8. The attenuation curve is plotted in Figure 9. Figure 8 clearly indicates the effect of the change of  $a$  from 1.00 to 1.035. It is seen, from the attenuation curve, that 0.005 db is not exceeded until  $b = 76^\circ$  and  $104^\circ$  which represents an improvement in frequency range of about 40% over the case for  $a = 1.00$  and  $n = 0.8$ .

The actual values which have been used above are selected arbitrarily and of course a similar elementary analysis can be carried out using other frequency ranges, values of allowable attenuation, and the corresponding values of  $a$  and  $n$ . In conclusion, a design of a double-stub support is offered, to operate about a midfrequency of  $f_0 = 750$  megacycles. Let us assume  $r_1 = 1.5$  cm.,  $a = 1.035$ ,  $n = 0.8$ , and  $Z_0 = 77$  ohms. The wavelength is

$$\lambda = c/f_0 = \frac{3 \times 10^{10}}{750 \times 10^6} = 40 \text{ cm}$$

The length of the stubs then must be about 10 cm, preferably with adjustable plugs at the ends  $c$  and  $d$  for allowing adjustments. (See Figure 4). The distance between  $a$  and  $b$

Products  
of  
**"MERIT"**

**OUTPUT TRANSFORMER**  
Hermetic-Sealed  
Glass Terminals

**Announcing!**  
Our new plant is now in full production, greatly increasing our capacity. We believe it to be the most modern and efficient unit now engaged in the production of transformers, coils and allied electronic equipment.  
Please take note of our new address, where you will always receive a cordial welcome.  
Sincerely yours,  
*Karl*  
President.

**MERIT COIL & TRANSFORMER CORP.**  
4427 North Clark St. CHICAGO 40, ILL.

*Laboratory Standards*



**PULSE GENERATOR**

**MODEL 79-B**  
SPECIFICATIONS:  
**FREQUENCY:** continuously variable 60 to 100,000 cycles.  
**PULSE WIDTH:** continuously variable 0.5 to 40 microseconds.  
**OUTPUT VOLTAGE:** Approximately 150 volts positive.  
**OUTPUT IMPEDANCE:** 6Y6G cathode follower with 1000 ohm load.  
**R. F. MODULATOR:** Built-in carrier modulator applies pulse modulation to any r.f. carrier below 100 mc.  
**MISCELLANEOUS:** Displaced sync output, individually calibrated frequency and pulse width dials, 117 volt, 40-60 cycles operation, size 14"x10"x10", wt. 31 lbs.  
 Price: \$295.00 F.O.B. BOONTON Delivery on priority

**MEASUREMENTS CORPORATION**  
BOONTON • NEW JERSEY



# DIALITE

by Micarta

- ★ Tough molded shell; high impact strength
- ★ Rigidly anchored to bracket to assure permanent position
- ★ Leads securely soldered, will not short inside shell
- ★ High dielectric strength
- ★ Unlimited mounting bracket possibilities for any requirement

A competent staff of engineers and designers is at your service to aid in solving your present and postwar problems and in developing new ideas. Complete facilities for the manufacture of terminal strips, coil forms, jack plugs, battery plug assemblies and resistor boards.

*Serving the Radio and Electronic Industry for Over 20 Years*



**MICARTA FABRICATORS, INC.**  
 5324 RAVENSWOOD AVENUE • CHICAGO 40, ILLINOIS • TELEPHONE LONGBEACH 9700

should also be 10 cm. The various radii are as follows:

$$r_1 = 1.5 \text{ cm}, \quad r_2 = 0.416, \quad r_3 = 0.302, \\ \text{and } r_4 = 0.435 \text{ cm}$$

The frequencies between which the loss will be about 0.005 db or less will be given by  $(f/f_0)^{90} = 76$  and 104. Thus  $f = 634$  and 866 megacycles are the limits of the band.

In the design of this double-stub support it may be advantageous to place the stubs at right angles to each other in order to increase the rigidity of the structure.

**Appendix: Calculation of Small Losses**

For the purpose of calculating losses which are the result of a very slight mismatch of impedances, the following development is presented. Let us assume a generator of unit emf, and an impedance  $Z_0/0^\circ$ . This generator works into an impedance  $Z_s/\theta^\circ$  where  $Z_s$  differs very little from  $Z_0$  and  $\theta$  is small. The condition is as shown in Figure 10.

The power delivered in the case where  $Z_s/\theta = Z_0/0^\circ$  is

$$P_1 = \frac{1}{4Z_0} \quad (a)$$

The power in the mismatched case  
 (Continued on page 88)

Figures 8 (right) and 9 (right, below) Figure 8, A and  $\theta$  for a double-stub support with  $a = 1.035$  and  $n = 0.8$ . Figure 9, loss in a double-stub support for two cases:  $a = 1.0, n = 0.8$ , and  $a = 1.035, n = 0.8$ .

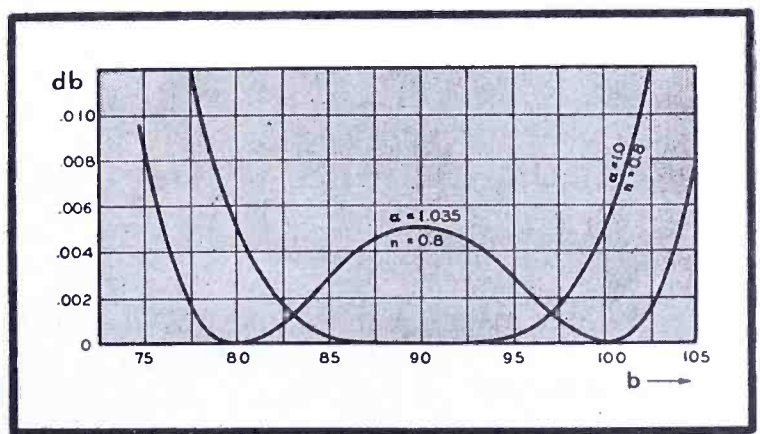
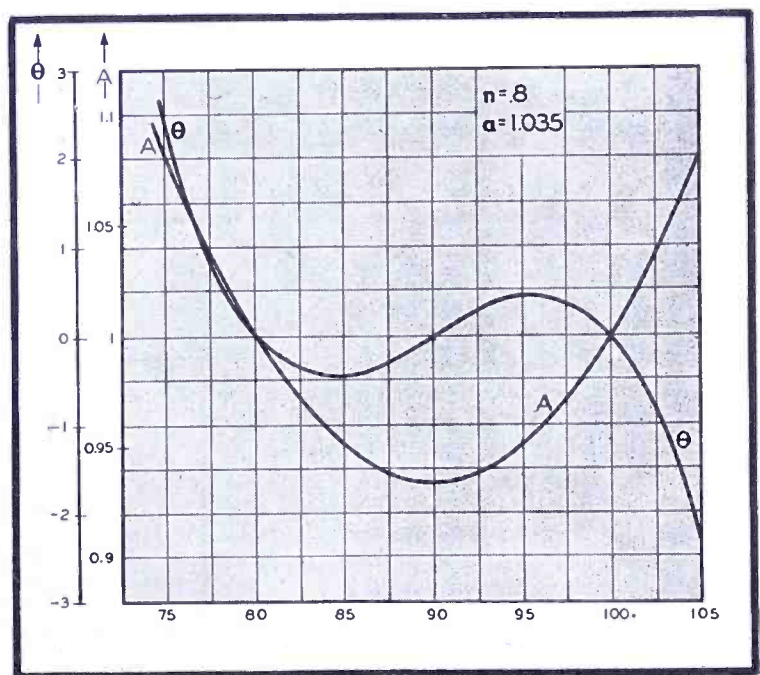

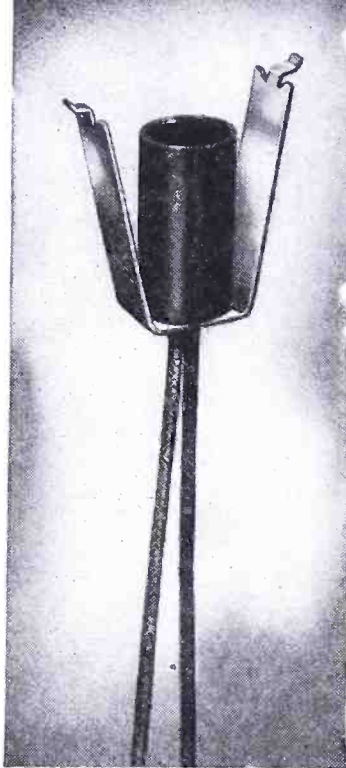

## Built-In Resistor Adapts this Drake Assembly for use with No. NE 51 NEON Lamps

THE DRAKE 500 Series Dial Light Assemblies are ideally suited for use with 110V NEON lamps, when equipped with a built-in resistor. Their many fine features have made the 500 Series a favorite. In fact, millions have been used since they were first introduced in March 1940! As world's largest exclusive producer of Socket and Jewel Pilot Light Assemblies, DRAKE facilities and long specialized experience assures top quality and speedy deliveries in any quantities. If you have a socket or jewel light problem, submit it to our capable engineers. Should a standard type prove unadaptable, they'll design and build a special type for your particular need. The Drake catalog contains a wealth of information on a big line of Pilot Light Assemblies. Do you have a copy?

No. 527F Tube



### PILOT LIGHT ASSEMBLIES

## DRAKE MANUFACTURING CO.

1713 WEST HUBBARD ST. CHICAGO 22, U.S.A.

# ENGINEERS....

## Are You Concerned With YOUR POST WAR FUTURE ?

The Federal Telephone & Radio Corporation, the manufacturing unit of the International Telephone & Telegraph Corporation with its multiple business activities extending to all parts of the civilized world, will accept applications from experienced men for immediate employment with almost limitless post war possibilities. These positions should interest those with an eye to the future and whose interest lies in forging ahead with this internationally known organization whose expansion plans for post war are of great magnitude covering all types of radio and telephone communications. Advancement as rapid as ability warrants. Majority of positions are located in the New York area!

We need the following personnel! Men with long experience or recent graduates considered.

- ENGINEERS
- ELECTRONICS
- ELECTRICAL
- RADIO
- MECHANICAL
- CHEMICAL
- TRANSFORMER DESIGN
- SALES AND APPLICATION ENGINEERS
- PHYSICISTS
- DESIGNERS
- DRAFTSMEN
- TOOL DESIGNERS
- TECHNICAL WRITERS

## Look Ahead With Federal!

If inconvenient to apply in person, write letter in full, detailing about yourself, education, experience, age, etc., to Personnel Manager.

FEDERAL TELEPHONE & RADIO CORP.

39 Central Avenue

EAST NEWARK

NEW JERSEY

is determined below.

$$I = \frac{1}{Z_0 + Z_s \cos \theta + jZ_s \sin \theta} \quad (b)$$

$$|I|^2 = \frac{1}{Z_0^2 + 2Z_0Z_s \cos \theta + Z_s^2} \quad (c)$$

and the power is

$$P_2 = \frac{Z_s \cos \theta}{Z_0^2 + 2Z_0Z_s \cos \theta + Z_s^2} \quad (d)$$

The ratio of powers is then

$$\frac{P_1}{P_2} = \frac{1}{4Z_0} \cdot \frac{Z_0^2 + Z_s^2 + 2Z_0Z_s \cos \theta}{Z_s \cos \theta} = \frac{Z_s}{Z_0} \cdot \frac{Z_0}{Z_s} + 2 \cos \theta = \frac{4 \cos \theta}{1} = 4 \cos \theta \quad (e)$$

Now let  $Z_s/Z_0 = 1 + a$ , and  $\cos \theta = 1 - (\theta^2/2)$ . Substituting into equation e:

$$\rho = \frac{1 + a + \frac{1}{1+a} + (2 - \theta^2)}{4 - 2\theta^2} = \frac{4 + 4a + a^2 - \theta^2}{4 + 4a - 2\theta^2} \quad (f)$$

neglecting terms in  $\theta^2 a$ . When equation f is divided out, the following approximate equation is obtained:

$$\rho \approx 1 + \frac{a^2 + \theta^2}{4 \frac{Z_s}{Z_0}} \quad (g)$$

The db loss is given by  $10 \log \rho = (10 \ln \rho)/2.3$

$$= \frac{10}{2.3} \ln \left( 1 + \frac{a^2 + \theta^2}{4 \frac{Z_s}{Z_0}} \right) \approx 1.085 \frac{a^2 + \theta^2}{\frac{Z_s}{Z_0}} \text{ db} \quad (h)$$

Equation h will give the db loss caused by any very slight mismatch. When the mismatch is considerable, however, it is necessary to use equation e.

Figure 10 Generator with mismatched impedances

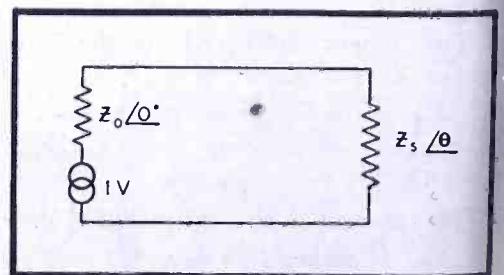

## NEWS BRIEFS

(Continued from page 83)

eds Miller McClintock, who retired. Mr. Koback was formerly executive vice president of the Blue network and before that ce president of NBC.

### I. E. MACFARLANE, IBS EXECUTIVE, DEAD

I. E. Macfarlane, chairman of the executive committee of the Mutual Broadcasting System, ce president of WGN, and business manager the "Chicago Tribune," died recently. Mr. Macfarlane was one of the founders of the Mutual Broadcasting System ten years ago. He was also the first president of the network, and served in that capacity for eight years.

### J. TRUMBULL BECOMES UNITED AIRLINE RESIDENT REP.

Justin Trumbull, formerly superintendent of aircraft radio electrical equipment for United Airlines at Chicago, has been named resident representative of United at the Douglas Aircraft Corporation in Santa Monica. He also is presenting Aeronautical Radio at Douglas.

### VELT NOW FONDA PRESIDENT

ving M. Felt has been named president of the Fonda Corporation, New York, and Edgar Ellinger, Jr., was appointed executive vice-president. Both executives hold similar posts at the Jefferson-Travis Radio Manufacturing Corp. and Union Aircraft Products Corp. Other officers appointed include Spencer C. Jones, vice president; Justin C. Harris, treasurer, and Frank Baron, secretary.

### HAINES CATALOG

A catalog describing wire-wound resistors (ratings, characteristics, bracket and terminal schematics), has been released by Haines Mfg. Corp., 246 McKibbin Street, Brooklyn 6, N. Y.

### WESTINGHOUSE ACQUIRES HAZELTINE LICENSE

Hazeltine license for home receiver manufacture was obtained recently by the radio division of the Westinghouse Electric and Manufacturing Company.

### STROMBERG-CARLSON TO MAKE WIRE RECORDERS

The Stromberg-Carlson Company have signed contract with the Armour Research Foundation to manufacture wire recorders.

### DOLPH GROSS LEAVES TERMINAL RADIO

dolph L. Gross has resigned as treasurer and stockholder of Terminal Radio Corporation, 85 Portland St., New York. Mr. Gross has been with the government's Electronic Research Supply Agency at 460 Fourth Avenue, New York, since May, 1943.

### WHITE STAR AND "E" AWARDS

ntinel Radio Corporation, 2020 Ridge Avenue, Evanston, Illinois, recently received the Army-Navy "E" award.

A second white star has been added to the "E" flags of the National Union Radio Corporation, De Jur-Amsco Corporation, and the Rola Company.

A fourth white star has been added to the "E" flag of the Hallicrafters Company.

### PRO PROCEDURE CHANGE

Provisions for securing priorities assistance in radio communication, broadcasting, commercial recording and public address systems for maintenance, repair and operating have been transferred from WPB Preference Rating Order 133 to Controlled Materials Plan Regulation and Direction 23 to CMP Regulation 5. Simultaneously Order P-133 was revoked.

In order to insure the adequacy of our foreign communications, United States international point-to-point radio communication companies may now secure special maintenance, repair and operating assistance under CMP Regulation 5, Direction 23. International point-to-point communication companies are defined as WFB as those owning stations licensed by the FCC to handle international communica-

# FOR SAFETY'S SAKE!

## Electro-Voice Hand-Held Differential Microphone

Model 205-S

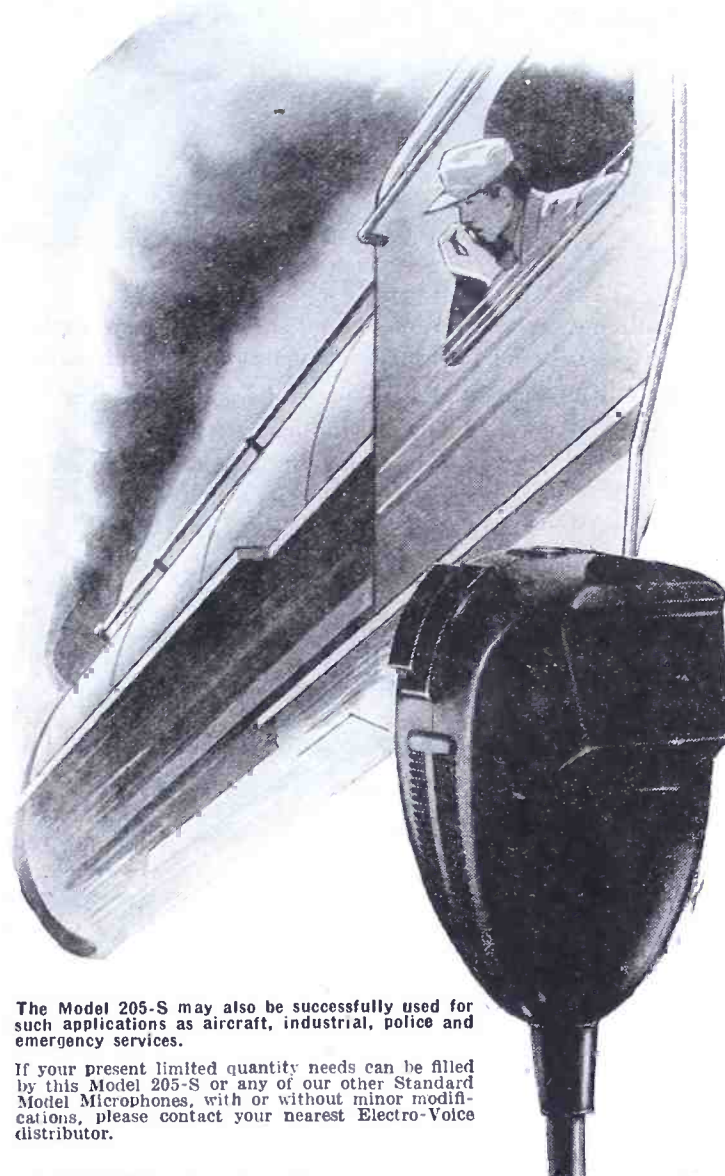

The Model 205-S may also be successfully used for such applications as aircraft, industrial, police and emergency services.

If your present limited quantity needs can be filled by this Model 205-S or any of our other Standard Model Microphones, with or without minor modifications, please contact your nearest Electro-Voice distributor.

The appalling number of railroad accidents in recent months has stimulated the demand for installation of radio communications on railway lines. Eventually, all lines will be thus equipped. Splendidly suited "for safety's sake" is the Electro-Voice Differential Microphone Model 205-S. A noise-cancelling microphone, it enables the transmission of voice clearly and distinctly, unaffected by shrieking whistles or grinding wheels. Ruggedly constructed, it can "take" the punishment of a hard-riding locomotive.

**FREQUENCY RESPONSE:** substantially flat from 100-4000 c.p.s.

**LEVEL:** -20 DB (0 DB = 1 volt/dyne/cm<sup>2</sup>)

**ARTICULATION PERCENTAGE:** 97% under quiet, 88% under 115 DB ambient noise

**TEMPERATURE RANGE:** -40° to +185°F

**WEIGHT:** Less than eight ounces  
**INPUT REQUIREMENT:** standard single button input  
**BUTTON CURRENT:** 10-50 milliamperes.

**MECHANICAL DETAILS:** molded, high impact phenolic housing. Minimum wall thickness, 3/8". Vinylite carbon retainer.

**SWITCH:** press-to-talk, with or without hold-down lock. Double pole double throw contacts provide an optional wide assortment of switch circuits. Standard circuit provides closing of button circuit and relay simultaneously.

**THERMAL NOISE:** Less than 1 millivolt with 50 milliamperes through button

**IMPACT RESISTANCE:** capable of withstanding more than 10,000 drops

**POSITIONAL RESPONSE:** plus or minus 5 DB of horizontal

**CABLE:** 5' three conductor, overall synthetic rubber jacketed

**BACKGROUND NOISE REDUCTION:** 20 DB and higher, depending on distance from noise source

# Electro-Voice MICROPHONES

ELECTRO-VOICE CORPORATION • 1239 SOUTH BEND AVENUE • SOUTH BEND 24, INDIANA  
Export Division: 13 East 40th Street, New York 16, N. Y., U. S. A. Cables: Arlab



tions, including code, voice and pictorial matter

The special rule allowing international point-to-point radio communication carriers to use MRO preference rating AA-1 for rearranging and modifying their facilities, formerly in P-133, will be continued under CMP-5.

Under CMP Regulation 5, stations will be able to use their MRO rating for the purchase of new equipment such as amplifiers, turntables, microphones, etc., whether for replacement or as additional equipment, provided the total value of the new equipment for any one capital addition does not exceed \$500. Another provision of the new ruling deletes the specific limit of spare tubes that can be kept on hand. Hereafter the total amount that may be spent for MRO under CMP-5 in any calendar quarter may not exceed one-fourth of the expenditures in the whole year 1942; except that if the present expenditures do not exceed \$5,000 a year, the purchases do not have to be based on 1942 purchases. WPB pointed out, however, that if this limitation works any hardship on a station, an appeal for increased MRO quota may be filed under CMP-5.

### McGIFFIN NOW G-M OF LEWYT

Roy McGiffin has been appointed general man-

ager of Lewyt Corporation, 136 Broadway, Brooklyn 11, N. Y.



### RMA PLANS POSTWAR PARTS STANDARDIZATION

The RMA engineering department and parts divisions have prepared for extensive standardization of radio components for postwar civilian production.

The parts standardization work of the engineering department will be under the immediate jurisdiction of the receiver section.

(Continued on page 90)

**BROADCAST ENGINEERS  
— POLICE RADIOMEN**

*Write Now!*

— on your phasing and tuning gear problems

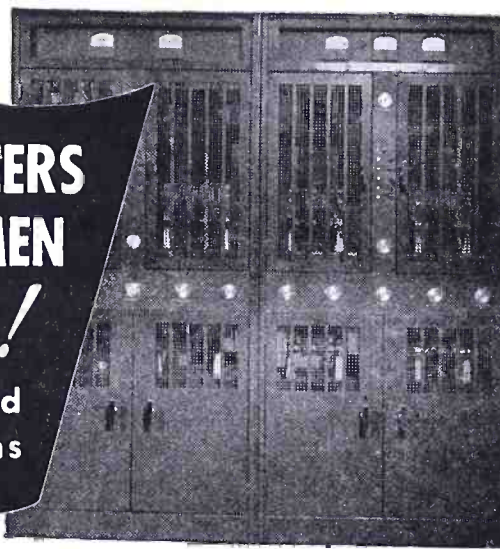

• Let us know *now* your requirements and specifications for *phasing and tuning gear* for your directional antenna. Andrew custom built equipment will again become available as soon as Uncle Sam releases our engineering and manufacturing facilities from production for war.

This release may come at any moment. Be sure that your needs are listed at the top of our peace-time back-log. The planning you do now will speed your own reconversion to the new high standards of the future.

Andrew engineers will gladly apply their years of skilled experience to the

solution of your special problems in the field of directional antenna equipment:

- Phasing networks and equipment
- Antenna tuning units
- Remote reading antenna ammeters
- Phase monitors
- Coaxial transmission lines and accessories

**ANDREW CO.**  
*ANDREW*  
**363 East 75th Street  
Chicago 19, Illinois**

D. Israel is chairman of this section, and H. C. Forbes is vice chairman. The latter will be the coordinator of parts standardization work of the receiver section and its various subcommittees.

The standards committees of the receiver components section of the RMA engineering department have been reorganized and now include: fixed capacitors, J. I. Cornell, chairman; electrolytic capacitors, H. E. Rice, chairman; mica capacitors, A. DiGiacomo, chairman; paper capacitors, Louis Kahn, chairman; variable air capacitors, Henry Sarkis, chairman; ceramic dielectric capacitors, J. D. Heibel, chairman; volume controls, H. W. Rubinstein, chairman; fixed composition resistors, D. S. W. Kelly, chairman; wire-wound resistors, Jess Marsden, chairman; plug-in resistors, Georg Mucher, chairman; sockets, S. Del Camp, chairman; speakers, W. A. Ellmore, chairman; high-frequency cores, no chairman as yet; power transformers, Arni Helgason, chairman; high-frequency circuit switches, Henry Richter, chairman; interruptors and rectifiers, H. M. Dressel, chairman; r-f and i-f transformers, Monte Cohen, chairman; dry batteries, L. M. Temple, chairman; and relay racks, P. K. McElroy, chairman. \* \* \*

**NEW CANADIAN DISTRIBUTOR FOR DU MONT**

Cyclograph Services, Ltd., 12 Jordon Street Toronto, Ontario, has been appointed distributor for Du Mont cathode-ray tubes, oscillographs and cyclographs in Canada. The Canadian appointee will function not only as a sales and field engineering organization, but also in the maintenance and repairs of Du Mont equipment in the Dominion, succeeding Burlec, Ltd.

**IRC NAMES BAGGS MERCHANDISING MANAGER**

Robert N. Baggs has been appointed manager of the merchandising division of International Resistance Company. Mr. Baggs was formerly advertising and sales promotion manager of the tube division of the Radio Corporation of America.



**FOLSOM HONORED BY NAVY**

The Distinguished Civilian Service Award was recently awarded to Frank M. Folsom, former chief of the Procurement Branch, Office of Procurement and Material in the Navy, for exceptional performance in that capacity from February, 1942, to December, 1943. Mr. Folsom is now a director and vice president of the Radio Corporation of America, in charge of the RCA Victor Division. \* \* \*

**HUDSON AMERICAN CRYSTAL BULLETIN**

A six-page illustrated brochure, "Frequency Etch," has been released by Hudson American Corporation, 25 West 43rd Street, New York. Included in the bulletin are specific hints on etching as well as a series of graphs showing the relation between etching time and the increase in frequency of BT crystals. The method used by one of the major crystal manufacturers in bulk etching crystals to frequency is also described. \* \* \*

**EVERITT ELECTED IRE PRESIDENT**

Dr. William L. Everitt has been elected president of the Institute of Radio Engineers for the coming year. Dr. Everitt, who is chief of the Operational Research Branch, Office of the Chief Signal Officer of the United States Army, succeeds Professor Hubert M. Turner of the Department of Electrical Engineering at Yale University, New Haven. Dr. Hendrik J. Van der Bijl of Johannesburg Union of South Africa, was elected vice president. Dr. Van der Bijl, fellow of the Institut

*Remember* **THE ISOSO-LOOP?**



This was the highest "Q" loop known. It went into vast numbers of pre-war receivers. For the present, all of our efforts are devoted to making DX Xtals but when Peace comes, we hope to be, once again, the World's Largest Loop-Aerial Manufacturers.

*May we help you with your post war plans?*

**DX CRYSTAL CO.**

GENERAL OFFICES: 1841 W. CARROLL AVE., CHICAGO, ILL., U.S.A.



TRADE MARK  
"the heart of a good transmitter"

since 1928, is chairman of the Electricity Supply Commission, the S. A. Iron and Steel Industrial Corporation, Ltd., and the Industrial Development Corporation of S. A., Ltd.; chairman and managing director of African Metals Corporation, Ltd.; director of the S. A. Board Barclays Bank; director general of War Supplies, and chancellor of the University of Pretoria, all of Johannesburg, Union of South Africa.

\*\*\*

#### CLARK CUTTING TOOL CATALOG

A 12-page adjustable cutting tool catalog has been released by Robert H. Clark Company, 2330 Santa Monica Blvd., Beverly Hills, California.

Featured are data on grinding fixtures, hole cutters, counterbores, tool holders, fly cutters, and boring bars.

\*\*\*

#### RAYTHEON ON NATIONAL NETWORK

The Raytheon Manufacturing Company is now broadcasting weekly over a coast-to-coast hookup on the Blue network. The famous All-Navy program, "Meet Your Navy," is being featured.

Broadcasts are made from the huge Great Lakes Naval Training Center at Great Lakes, Illinois.

\*\*\*

#### CARTER MOTORS APPOINTS EXPORT AGENTS

Williams & Associates, 540 N. Michigan Blvd., Chicago, have been appointed Carter Motor export agents in Mexico, Central and South America, and the continent of Africa by Robert W. Carter, managing director of Carter Motor Company, 1608 Milwaukee Avenue, Chicago.

Frazar & Hansen, 301 Clay Street, San Francisco, California, will act as Carter Motor export agents for China, Philippines, and the Far East including Australia, New Zealand and India.

\*\*\*

#### SHAW BECOMES TAYLOR TUBE CHIEF INSPECTOR

William Shaw, formerly engineer for G. E. X-Ray Company, has been appointed chief inspector of Taylor Tubes, Inc., 2312 Wabansia Avenue, Chicago.

\*\*\*

#### RADIO CLUB HEARS RAGAZZINI AND SHANK

A paper, on "Fluctuation Noise as a Factor in Receiver Input Circuit Design," was delivered by Dr. John R. Ragazzini, assistant professor in electrical engineering, Columbia University, before the Radio Club of America at Havemeyer Hall, Columbia University.

A discussion of the origin of fluctuation voltages in circuit elements served as the basis for the paper.

Eugene R. Shank, research engineer of the RCA Laboratories, presented a paper on "Controlled and Uncontrolled Multivibrators" at another RC of A meeting at Columbia University.

In the course of the paper an equation relating the natural frequency of the multivibrator to the characteristics of the tubes and circuit components was developed on the basis of simple capacitor-resistor time constants. Information about the natural frequency stability was also given. The synchronizing of the multivibrators was also considered in some detail.

\*\*\*

#### UNIVERSAL MICROPHONE 16 YEARS OLD

Universal Microphone Co., Inglewood, Cal., observed its 16th birthday in October.

\*\*\*

#### TEN NATIONAL REPS FOR HAINES

Ten national sales representatives have been appointed by Haines Manufacturing Corp., 248 McKibbin Street, Brooklyn, New York.

The representatives are: R. A. Adams, Detroit 21, Michigan; Hal F. Corry, Dallas, Texas; Jack Heimann, Minneapolis, Minn.; Royal Higgins, Chicago 5, Ill.; Russ Hines, San Francisco, Calif.; J. P. Kay, Kansas City 6, Mo.; Bert Knight, Los Angeles 15, Calif.; John O. Olsen, Cleveland, Ohio; Perry Sattler, New York 7, N. Y.; and Henry P. Segel, Boston 16, Mass.

\*\*\*

#### CANNON SOLENOID BULLETIN

A 32-page bulletin on d-c solenoids has just been issued by Cannon Electric Development Company, 3209 Humboldt Street, Los Angeles 31, California. Appearing are photographs of direct current solenoids, together with tabu-

(Continued on page 92)

BACK THE INVASION—BUY MORE BONDS NOW!



# ORIGINATORS

## OF THE FINEST-MADE AND MOST-WIDELY IMITATED PILOT LIGHT ASSEMBLIES

Dialco creative Engineering has originated numerous types of Pilot Lights which set the standard for the industry. COMPLETE WITH LAMPS: To speed production we offer a vast line of Pilot Lights completely assembled with proper G.E. or Westinghouse Lamps. SPECIALISTS IN NEON APPLICATIONS. . . . Send specifications for immediate solution of your problem. Write for complete Catalogue.

**YOU CAN DEPEND ON DELIVERIES  
WHEN YOU DEAL WITH THE**

World's Largest  
Manufacturer of Pilot Lights



# DIAL LIGHT CO. *of America, Inc.*

900 BROADWAY • NEW YORK 3, N. Y.  
Telephone: ALgonquin 4-5180-1-2-3

BACK THE INVASION—BUY MORE BONDS NOW!

# Look! a production standard

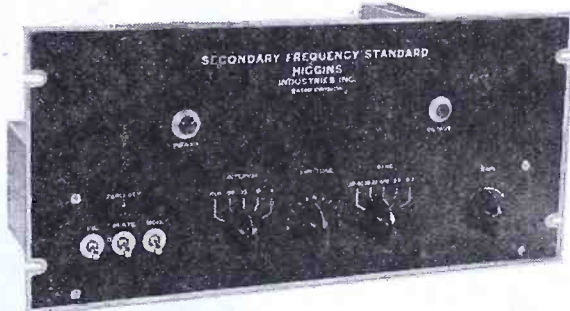

● ● ●

**A Complete Secondary Frequency Standard Specifically Designed for routine production line operations.**

**MODEL FS-10:** 1. 1000; 100; 25 and 10 kilocycle intervals • 2. Ample RF output • 3. Built in modulator, 1000 cycle tone • 4. A crystal stability of at least 1 cycle per megacycle per degree centigrade • 5. 105 to 120 v., 50 to 60 cycle, A.C. operation. Output unaffected by line variations • 6. Standard relay rack mounting • 7. Multivibrators stable under extreme line voltage variations

**MODEL FS-11:** 1. Same as the Model FS-10 except for an additional interval as required by YOUR type of work!

*Prices and literature upon request*

# Higgins

**INDUSTRIES INCORPORATED**

2221 Warwick Avenue

Santa Monica, California

# FROM THE HOUSE OF JACKS

... and other radio and electronic components!

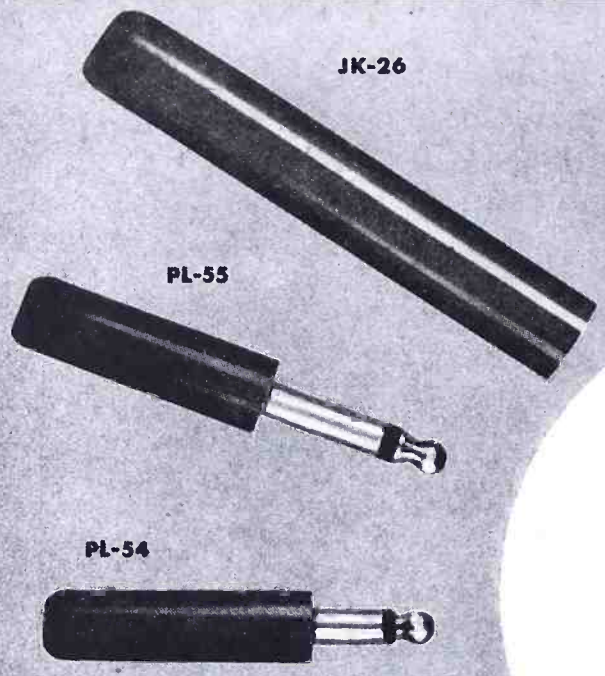

JK-26

PL-55

PL-54

America's largest producer of JK-26 jacks. All models built to strict Signal Corps specifications.

### Experience for Sale!

Amalgamated Radio, pioneers in the field, maintain experimental and development laboratories for post-war radio and television equipment. Our components are completely engineered in a self-contained factory equipped with tools of our own design. Years of specialized experience assure high quality products at low cost. *Inquiries are invited.*

ADDITIONAL JACKS & PLUGS FOR IMMEDIATE DELIVERY  
JK-55 JK-48 PL-291 PL-291A PL-204

## AMALGAMATED RADIO TELEVISION CORP.

476 BROADWAY • NEW YORK 13, N. Y.

# If you want

- CRYSTALS
- CABLES
- HARNESES
- ELECTRONIC ASSEMBLIES
- CABINETS

Telephone Peru, Indiana

151

*Serving the Radio and Electronic Industries with precision engineered products.*

# Wm. T. WALLACE MFG. CO.

General Offices: PERU, INDIANA

Cable Assembly Division: ROCHESTER, INDIANA

## NEWS BRIEFS

(Continued from page 91)

lar data, dimensional drawings, wiring diagrams and response characteristic charts.

### BURLEC APPOINTS COMMANDER MILLARD CHIEF ENGINEER

Commander John R. Millard, RCNVR, has been appointed vice president and chief engineer of Burlec, Limited, Toronto 13, Canada.

For the past year Commander Millard has been serving at Naval Service HQ as director of technical research.

### BOSTON FIRE DEPARTMENT USING 2-WAY RADIO

The Fire Department of Boston, Massachusetts, is now using an f-m two-way system, installed by Galvin. Call letters are WEY, operating on a frequency of 37.74 mc.

Thirty-three mobile fire department units, including three fireboats, and the cars of the district and deputy fire chiefs, are equipped with two-way transmitters and receivers.

The central control station antenna is mounted 420 feet above sea level.

### HUBBELL NOW WITH CROSLY

Richard W. Hubbell has been appointed broadcasting production manager for the Crosley Corporation.

Hubbell is the author of "4,000 Years of Television," and was formerly with WQXR and CBS.



### GUARDIAN RELAY AND SOLENOID FOLDER

A four-page illustrated bulletin offering data on eight relays and eight solenoids has been published by Guardian Electric Mfg. Company, 1623 West Walnut Street, Chicago 12, Illinois. Relay charts show standard voltages, maximum contact capacity, coil resistance, and operating current. Solenoid charts give resistance and operating current at standard voltages and show stroke and lifting capacity of small solenoids.

### AMP CATALOG

A 20-page catalog, 33, describing the design possibilities in solderless wiring systems has been released by Aircraft-Marine Products Inc., 1591 F North Fourth Street, Harrisburg, Penna.

Featured are data and illustrations on connector blocks, multiple connectors, connector strips, bus bars, terminals, etc.

### ELECTRO-VOICE BOOKLET

A six-page booklet covering communications microphones has been issued by the Electro-Voice Corporation, 1239 South Bend Avenue, South Bend 24, Indiana.

Appearing in the booklet are data on the lip-type 245, or differential microphone; the hand-held 205-S, the noise-cancelling microphone; and the dynamic 600-D.

### FTR BULLETINS

Twelve new bulletins on transmitters, coaxial cables, r-f heating units, selectors, and general products, have been released by the Federal Telephone and Radio Corporation. Transmitter bulletins cover 5-kw broadcast, 20-kw h-f, multi-unit and marine units. Coaxial bulletins describe high frequency solid dielectric cables. The megatherm is described in the r-f heating bulletins. Application data also appear in these bulletins.

### C-D FIBRE COMPANY CATALOG

A 12-page catalog, GF-51, with design and application data on dilecto, dilectene, celeron, micabond, vulcoid and vulcanized fibre, has

# A STRONGER FACTOR in TODAY'S NEW COMPLETE CIRCUIT PROTECTION



## EXTRACTOR POSTS

WITH WELDED ANTI-VIBRATION  
SIDE TERMINALS

NOW UNDERWRITERS' APPROVED

Resistance to extremes of shock, vibration and temperatures is provided by the new Littelfuse Extractor Posts with electrically welded side terminals. By Littelfuse process, terminals are made integral with inside metal shell. Maximum conductivity is insured. Other Littelfuse improvements for dependability, durability, and convenience make these extractor posts outstanding examples of Littelfuse complete circuit protection.

### EXTRACTOR POST No. 342001 for 3 A G Fuses

Finger-operated. Welded side terminals. Knob and body black bakelite. Positive fuse grip. Full visual shock-proof inspection. Spring-activated cup. Specially designed grip prevents fuse from dropping out.



Also furnished screw-driver operated (341001), meeting Underwriters' specifications.

Send for B/P and ENGINEERING DATA  
Ask for Samples

Safeguard new equipment, or irreplaceable present equipment. Fuses, Fuse Clips, Fuse Panels, Circuit Breakers, Thermocouples, Fine Wire Products, Indicators, etc.

## LITTELFUSE INCORPORATED

4757 Ravenswood Ave., Chicago 40, Ill.  
200 Ong St., El Monte, Calif.

been released by the Continental Diamond Fibre Company, Newark 51, Delaware.

### CRYSTAL PRODUCTS CATALOG

A 32-page illustrated catalog of quartz crystal units has been released by Crystal Products Company, Kansas City, Missouri. The catalog is indexed to include all fields: broadcasting, filter, test, amateur, aircraft, police-marine, multiple crystal units and blanks. Various types of crystals for each of these services are described and illustrated with cross-sectional photos and drawings.

### WESTINGHOUSE NAMES LOHR MARKET DEVELOPMENT HEAD

A. W. Lohr has been appointed acting manager of the market development department at Westinghouse, in East Pittsburgh, during the absence of Donald C. Hooper, who is now in the U. S. Navy.

### BUTTERFLY CIRCUIT DATA IN G.R. BULLETIN

An analysis of the high-frequency butterfly circuit, by Edward Karplus, appears in the October issue of the General Radio Experimenter.

### HARCO ANTENNA CATALOG

An assortment of masts and towers are described in a 24-page catalog released by the Harco Steel Construction Co., Inc., Elizabeth, N. J. Detailed and illustrated are tubular masts, portable tubular masts, straight triangular towers, tapered triangular towers, straight square towers, tapered square towers, mobile masts and towers, and special types.

### ONAN GENERATING PLANT FOLDER

A folder describing a-c and d-c generating units for high and low powers has been released by D. W. Onan & Sons, 39-51 Royalston Avenue, Minneapolis, Minn.

### STERNKOPF NOW WITH UNIVERSAL COIL

B. J. Sternkopf, formerly of Sperry Gyroscope, has joined Universal Coil Manufacturing Company, 1138 Broadway, Brooklyn, as sales manager. Martin L. Green is owner and chief engineer of the company, which was formerly known as Universal Sound Laboratories.

### BENDIX OPENS R.R. RADIO ENG.-SALES-SERVICE UNIT

An engineering, sales and service organization to coordinate expanding activities in railroad radio has been established by the Bendix Radio Division of Bendix Aviation Corporation.

R. B. Edwards has been named engineering coordinator for the group, which will be under the general direction of W. L. Webb and John W. Hammond, chief engineer and sales manager, respectively.

### FINN AND COCKE BECOME RCA REGIONAL MANAGERS

David J. Finn will manage RCA product distribution in the Chicago region. James W. Cocke has been named manager of RCA product distribution in the Dallas, Atlanta region.

Mr. Finn was formerly sales manager for the RCA industrial and sound department.

Mr. Cocke has directed sales activities for RCA in Dallas and Atlanta for many years.

### COUGHLIN NOW P-A FOR UNITED ELECTRONICS

Peter J. Coughlin has been named purchasing agent at United Electronics Company, Newark 2, N. J.

Mr. Coughlin was formerly with Titeflex.

### SYLVANIA SPECIAL ELECTRONIC PRODUCTS BULLETIN

Nine types of electronic tubes for specialized applications are described in a 24-page bulletin, 202, published by Sylvania Electric Products, Inc., Special Products Division, 60 Boston Street, Salem, Mass.

Products described include stroboscopes for the study of reciprocating and rotating motion; Pirani and thermocouple tubes for measuring vacuum; voltage regulator tubes; facsimile tubes; germicidal tubes; black light and near ultraviolet lamps. Technical sections of the bulletin give specifications, basic circuit diagrams and suggested applications for products and accessories.

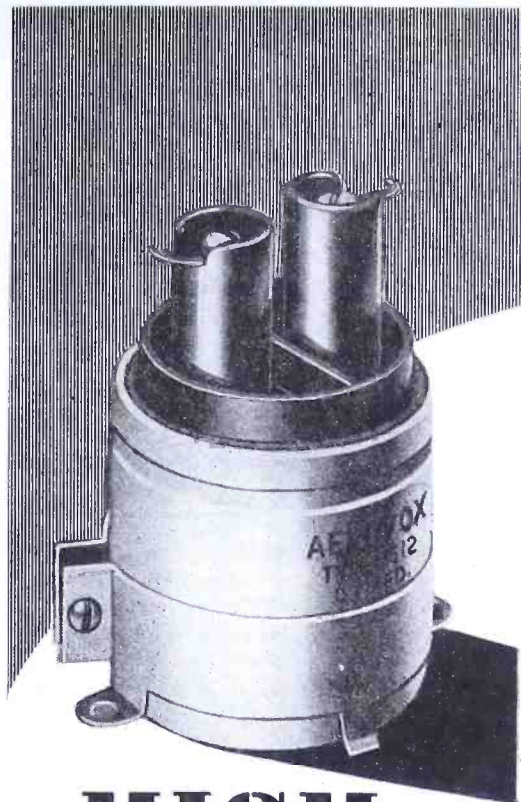

# HIGH-VOLTAGE requirements

● Aerovox Type 12 is an immersion-proof oil-filled paper capacitor designed to meet high-voltage, high-altitude operating requirements. Particularly suitable for high-voltage circuit applications such as in television, cathode-ray tube power supplies, high-voltage rectifier circuits, aircraft transmitters, or as a high-voltage by-pass capacitor. Note barrier in bakelite top. This further increases insulation and creepage path between terminals.

### AEROVOX TYPE 12 HYVOL

Supplied with adjustable mounting ring for vertical mounting.

For certain less critical applications, ceramic insulators may be removed and unit used without them.

Voltage ratings from 2000 to 7500 volts d.c.w. Capacitances from .01 to 2.0 mfd., depending on voltage.

For high-voltage high-altitude operation, particularly aircraft, units can be had with special porcelain cover and single, taller insulator pillar terminal with corona shield.

● Write for Literature . . .



AEROVOX CORP., NEW BEDFORD, MASS., U. S. A.

In Canada: AEROVOX CANADA LTD., HAMILTON, ONT.

Export: 13 E. 40 St., New York 16, N. Y. Cable: ARLAB

# STAMINA



The inherent stamina of Cinaudagraph Speakers is due to experience in design and manufacturing plus highest inspection standards. In all types of Cinaudagraph Speakers, from small watch-like Handie-Talkie units to large auditorium speakers, you'll find the same precision, the same painstaking workmanship and the same long-lived faithful reproduction.

Watch Cinaudagraph Speakers after Victory!



**Cinaudagraph Speakers, Inc.**

3911 S. Michigan Ave., Chicago

Export Div., 13 E. 40th St., New York 16, N. Y.

*"No Finer Speaker Made in all the World"*

ENGINEERS: Here's  
the **BIG POINT** about  
**AMPERITE**  
**REGULATORS**

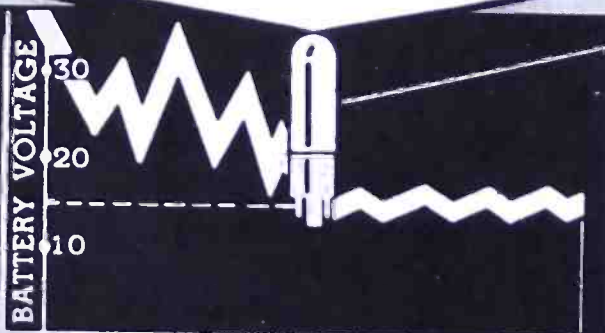

VOLTAGE OF 24V  
BATTERY & CHARGER  
VARIES APPROX.

**50%**

WITH AMPERITE  
VOLTAGE VARIES  
ONLY

**2%**



*Features:*

1. Amperites cut battery voltage fluctuation from approximately 50% to 2%.
2. Hermetically sealed — not affected by altitude, ambient temperature, humidity.
3. Compact . . . light . . . and inexpensive.

Used by U.S. Army, Navy, and Air Corps.

**DELAY RELAYS:** For delays from 1 to 100 seconds.  
Hermetically sealed. Unaffected by altitude. . . . Send for catalogue sheet.

NEW! 4-page folder will help you solve Current and Voltage Problems; contains much valuable data in practical form — Write for your copy now.

**AMPERITE CO., 561 Broadway, New York (12), N. Y.**

In Canada: Atlas Radio Corp., Ltd., 560 King St., W. Toronto

# THE INDUSTRY OFFERS . . .

## DAVEN DUAL-UNIT ATTENUATOR

Improved model dual-unit attenuators have been developed by the Daven Company, 191 Central Avenue, Newark, New Jersey.

The dual-unit construction is featured in balanced H attenuators, as well as in special multi-circuit controls of the potentiometer, T ladder, L, and rheostat types.

The new model has fungus and mildew-resisting varnish on all bakelite parts and resistive windings; contact and switch blades are of tarnish resistant, silver alloy. Other features are: separable coupling; new detent device with gear and roller mounted in recessed front end of front unit, separate from resistive network; and extrusion of detent gear and steel attenuator cover for stop to rotation.

Rear of panel depth, 3 7/8".

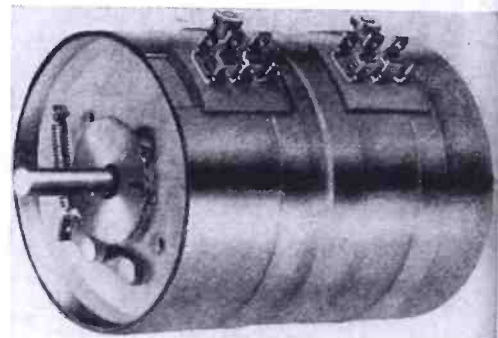

## HERMETICALLY SEALED SOLA TRANSFORMERS

Hermetically-sealed constant voltage transformers for through-chassis mounting, and for such applications as heating and refrigeration controls, television and f-m receivers, vacuum tube voltmeters, electronic gauging and inspection equipment, photometric instruments, etc., have been announced by Sola Electric Company, 2525 Clybourn Avenue, Chicago 14, Illinois.

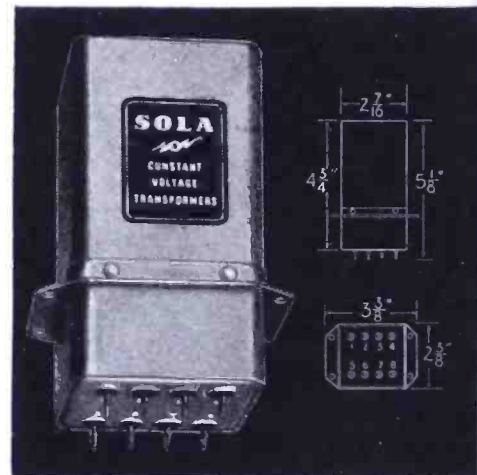

## LITTELFUSE BREAKERETTES

Push-breaker type circuit breakers, Breakerette 1561, rated at 32 volts a-c or d-c, interchangeable with all 5 A G fuses, or Navy midjet size are being produced by Littelfuse Incorporated, 200 Ong St., El Monte, California; 4757 Ravenswood Ave., Chicago 40, Illinois. Break is snap action capable of interrupting short circuits of 1,000 amperes in ratings up to 5 amperes and 2,500 amperes in ratings over 5 amperes capacity. Time characteristics of the fuses are duplicated electrically. Provided with 5 A G caps to fit into standard 5 A G fuse clips.

In operation, when the bi-metal releases the push-button on which it acts directly, a double break of the circuit is effected. The actual breaking distance is 1/8". To reset, the button is merely pushed into its bottom position with respect to the case. Both trip-free and non-trip free features are provided.

Trip-free shield is thermoplastic to permit visual indication when breaker is tripped. Ex-



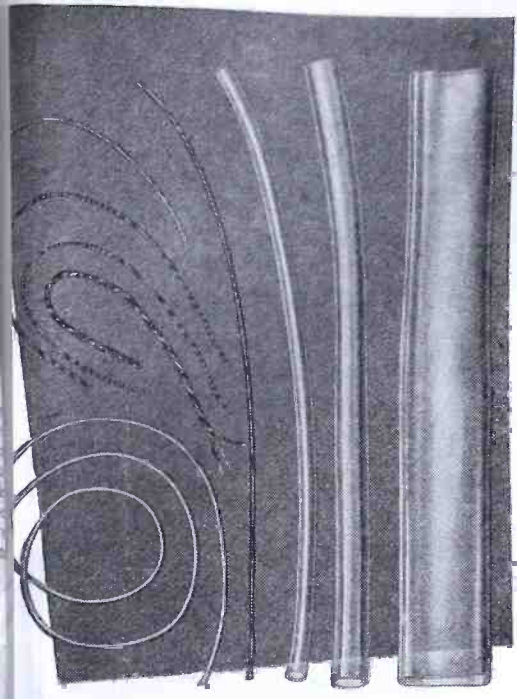

**"SURCO AMERICAN"**  
**Plastic Insulation**  
*fills every one of*  
*your specifications*

You need only to list your specifications to obtain exactly the qualities you require in "Surco-American" Flexible Plastic Tubing. Our own formulations, are rigidly tested to withstand the widest range of conditions, temperature extremes, non inflammability, ageless durability, maximum flexibility; proof against moisture and all kinds of weather. Available in continuous lengths, inside diameters from .005 to 2", packed exclusively to maintain original round form. Other features of "Surco-American" formulations are non fogging, high insulating resistance, dielectric strength which averages 1500 volts per mil. thickness, resistant to abrasion, clear and in all colors. "Surco-American" tested products also include: flexible plastic insulated wire in all colors and sizes, insulating tape, special tubing and wire. Complete technical data.

**Surprenant**  
**ELECTRICAL INSULATION CO.**  
 Dept. L.  
 84 PURCHASE ST.  
 BOSTON MASS.

tre dimensions  $1\frac{1}{8}$ " long x  $\frac{3}{4}$ " wide; overall height with trip-free shield is  $1\frac{1}{4}$ ". Weight, 15 grams without hood, 18 grams with hood. It fits into clips on  $\frac{7}{8}$ " spacing or more.

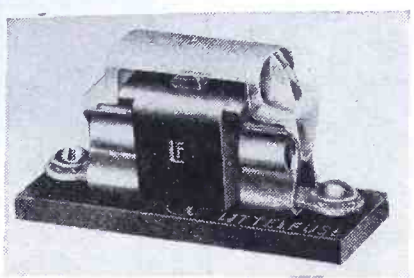

**ANDREW ANTENNA-TUNING UNIT**

For coupling a vertical tower antenna to a coaxial transmission line, Andrew Co., 363 E. 75th Street, Chicago 19, have produced an antenna tuning unit, type 48. An L network is used. Elements are variable.

Features are: built-in isolation filter, to permit connecting coaxial transmission line to u-h-f antenna on top of tower. This permits operation of an h-f "talk-back" antenna on top of a low frequency tower. A standard broadcast station would use this feature to connect a coaxial transmission line to a phase sampling loop, or to an f-m antenna; built-in tower lighting filter, to facilitate feeding aircraft warning lights on top of tower; and plug-in meter positions, to facilitate temporary metering in all branches of the circuit during adjustment.

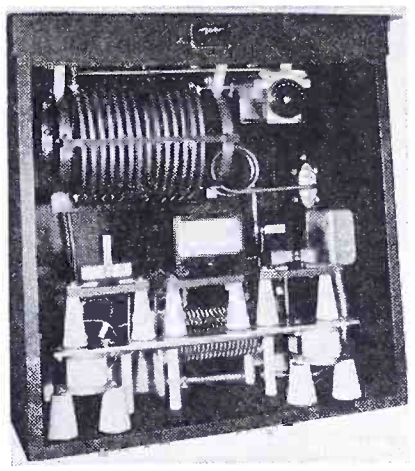

**FTR AUTOMATIC SELECTORS**

A high-speed, multi-contact automatic selector, FTR 800, is now being manufactured by Federal Telephone and Radio Corporation, Newark, N. J.

The rotor assembly is operated by a stepping mechanism which responds to impulses of current. After each impulse, a reed suspended pawl engages a ratchet, moving the wipers one step forward over the bank contacts. By this method, connections are made from circuits (connected to wipers) to other circuits (connected to the bank assembly).

The stepping mechanism may be controlled manually by a dial or other means. Automatic control for the stepping magnet may be provided by interrupter springs, electronic circuits or relay circuits.

The wipers on the rotor may be of either of two types: double-ended or single-ended. According to the type of wiper used, this selector can be arranged to have a capacity of from one to three 2-row levels of 22 points each or from one to six single-row levels of 11 points each.

In the case of the double-ended type wiper, one end wiper over a row of 11 contacts during the first half revolution of the rotor and the other end wiper over the same row of contacts during the second half revolution. A single-ended wiper consists of two electrically connected, single-ended units mounted 180 degrees apart and axially staggered. Two rows of bank contacts are wiped over alternately during each revolution by the two staggered ends and are thus equivalent, electrically, to a single row of 22 contacts.

The wipers can be either bridging or non-bridging. The non-bridging wiper passes from one contact to the next without short circuiting the adjacent contacts. A bridging wiper connects with one contact before disconnecting from the adjacent contact. When the step is completed, the wiper is connected to one contact only.

When required, the selector can be arranged  
 (Continued on page 96)

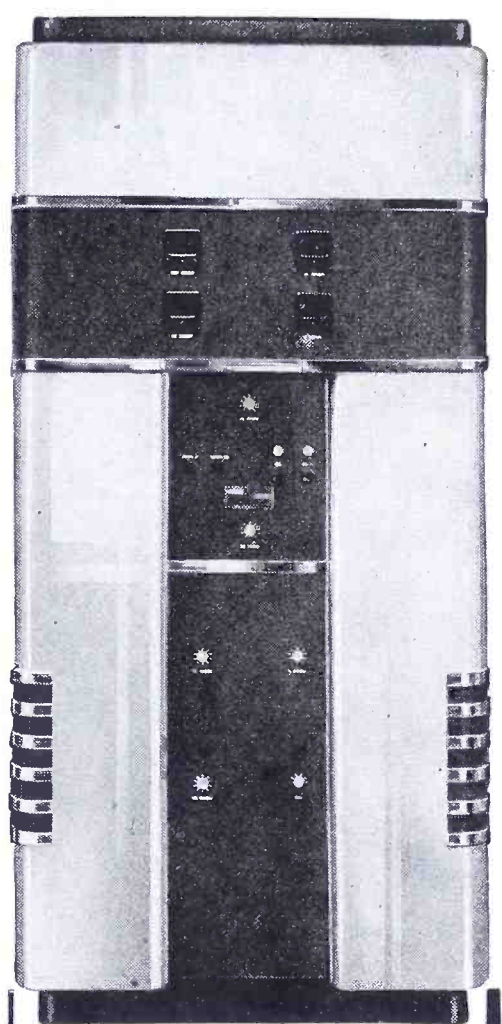

**Broadcast Station**  
**Directional Equipment**

Have you investigated the possibilities of increasing power by installing directional antenna equipment to "protect" other near-by stations on your frequency? If not, this should definitely be a part of your Post-War plans.

Johnson Engineers are pioneers in the directional antenna equipment field. They have completed and delivered 39 such units (probably more than any other manufacturer) and it is not too soon to place your order for Post-War delivery.

Johnson service includes working in cooperation with your consulting engineer in design of the equipment, building the phasing unit with cabinet to match your other equipment, furnishing tower coupling units, and furnishing concentric line, gas equipment and other accessories.

Write to Johnson today for further information and estimates.



**JOHNSON**  
*a famous name in Radio*  
 E. F. Johnson Co. Waseca, Minn.

# RELAYS by KURMAN

Twenty-five years' experience in solving all types of Relay Problems. Complete facilities for Designing, Engineering, Manufacturing. Specialists in producing Relays of exceptional power and sensitivity for Aircraft, Intercommunications Systems, Electronic Devices. Exclusive Kurman features provide greater dependability, longer life, more precise performance.

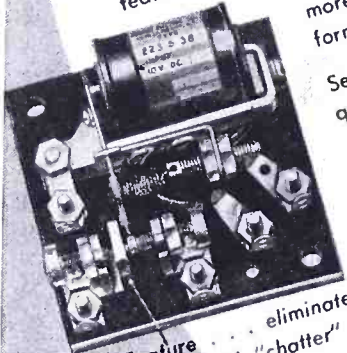
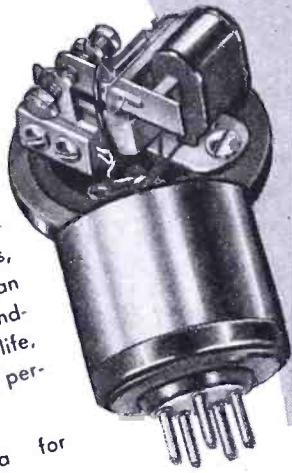

New Feature eliminates "bounce" and "chatter"

Send data for quotations.

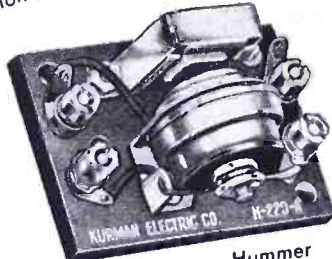

Microphone Hummer

## KURMAN ELECTRIC CO.



35-18 37th STREET • LONG ISLAND CITY I, N. Y.

# RUBYFLUID

... will solve any soldering problem ...

Ruby's Stainless Steel Flux makes joining this metal easy, economical. For general soldering and tinning, liquid or paste Rubyfluid is the perfect flux. Wets out freely—no harmful fumes.



Ask your jobber or write direct.

**RUBY CHEMICAL CO.**  
58 McDowell St. - Columbus, Ohio

# Rubyfluid

**CRYSTALS  
EXCLUSIVELY**



**SINCE  
1934**

ORDERS SUBJECT TO PRIORITY  
**PETERSEN RADIO CO., Council Bluffs, Iowa**

• **Ted McElroy**

World's Largest Manufacturer of  
Wireless Telegraphic Apparatus

COMPLETE CENTRAL OFFICE EQUIPMENT

**McElroy Manufacturing Corp.**

82 Brookline Avenue • Boston, Massachusetts

for homing, that is, the rotor will return automatically to normal position.

Selector is 2 1/2" x 3 1/4" x 3 1/2". Said to have an operating life of 4,000,000 revolutions at operating speeds up to 60 steps per second.

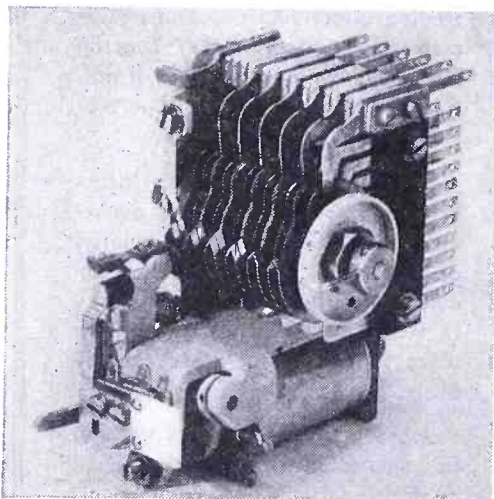

### GREEN MULTI-RECTIFIERS

Multi-rectifiers with six selenium rectifier sections which may be interconnected by external links to provide four ranges of d-c were recently developed by Green Electric Laboratories, 130 Cedar Street, New York 6, N. Y.

The rectifiers provide: 0-8 volts, maximum capacity 100 amperes; 0-16 volts, maximum capacity 50 amperes; 0-24 volts, maximum capacity 35 amperes; and 0-48 volts, maximum capacity, 18 amperes.

A built-in voltmeter and ammeter indicate d-c output voltage and current. Red line calibrations indicate the maximum current limitation on each range.

On each side of the rectifier cabinet are wing nut terminals for convenience in connecting loads.

Additional features include a three-phase magnetic contactor in the main power supply

### THE INDUSTRY OFFERS ... —

(Continued from page 95)

circuit with on-off push buttons, pilot lamp, monitor lamp, buzzer (overload warning), and an automatic watchman which provides automatic current interruption in case of prolonged overload.

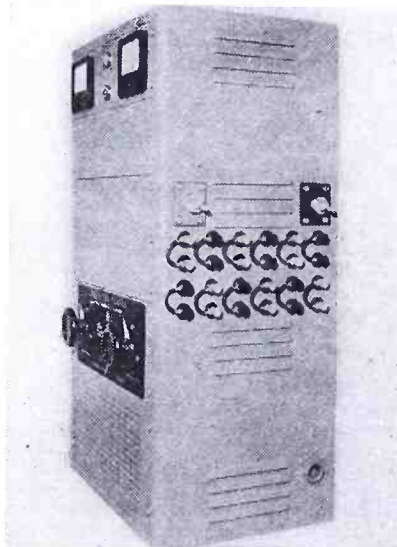

### UTC INTERSTAGE FILTERS

Two interstage filters, types BPI and BPL, for 200 to 10,000 cycles, have been developed by United Transformer Co., 150 Varick Street, New York 13, N. Y. These filters are sharply peaked, having approximately a 2 db attenuation of frequencies plus or minus 3% from the mean frequency, and attenuations of approximately 40 db per octave. They are adjusted to zero phase shift at the mean frequency.

The BPI type has a primary impedance of 10,000 ohms; for operation from the plate of a triode tube to a succeeding grid. Gain is approximately 2 to 1. Type BPL filters are designed to operate from a line impedance of

either 500 or 600 ohms to the grid of a tube. The gain is about 9 to 1.

Hermetically sealed case of BPI type, 1 1/2 x 2 1/2 x 2 1/2.

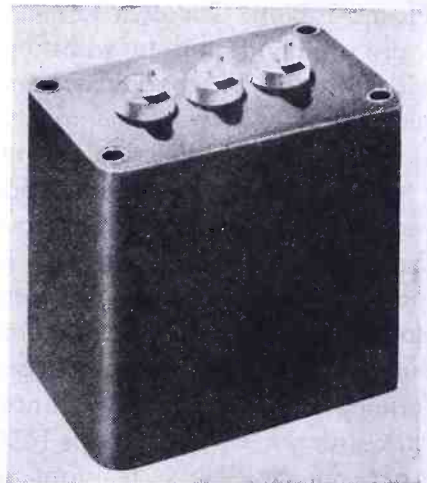

### GUARDIAN MIDGET RELAY

A 1.2-ounce, single-pole single-throw midget relay has been produced by Guardian Electric Manufacturing Company, 1623 West Walnut Street, Chicago 12, Illinois. Measures 1 9/32" x 1 5/32" x 29/32".

Operates on d-c only, and is said to have a switch capacity of double pole, double throw with 1.5 ampere contacts.

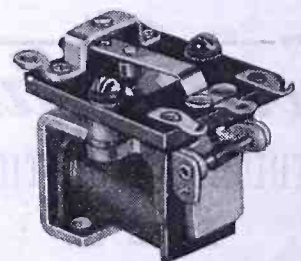

### RAWSON ELECTROSTATIC VOLTMETER

Electrostatic voltmeters, type 518, for the meas-

# PLASTIC NAME PLATES

SCALES, GAUGES,  
CALCULATORS,  
CHARTS,  
DIALS,  
ETC.

- Impervious to moisture, grease, oils, acids, alkalis.
- Printing guaranteed not to wash or rub off.
- Non-inflammable, non-corrosive plastic.
- Printed and laminated vinylite and cellulose acetate.

SAMPLES AND ESTIMATES GLADLY SUPPLIED ON REQUEST  
WRITE DEPARTMENT C.

**THE HOPP PRESS, INC.**

PRINTING — FABRICATING — FORMING

460 W. 34th STREET, N. Y. C.

ESTABLISHED 1893

**CORWICO**

# WIRES

MADE BY

*Engineers FOR  
Engineers*

**VICTORY**

concentrating upon  
for the duration . . . .

**cornish**  
WIRE COMPANY, INC.

15 Park Row, New York City, New York

**CORWICO**

urement of a-c or d-c high voltages have been developed by Rawson Electrical Instrument Co., 113 Potter Street, Cambridge 42, Mass. Exact rms readings on a-c are said to be available with no errors due to frequency or waveform.

For d-c measurements there is said to be no appreciable current drain, as the resistance is guaranteed to be higher than one million megohms.

For a-c measurements the input capacitance is around 10 micromicrofarads, drawing negligible current at low frequencies.

Meters are offered in ranges of 1, 2, 3, 5, 10, and 20 kilovolts full scale; accuracy 1%.

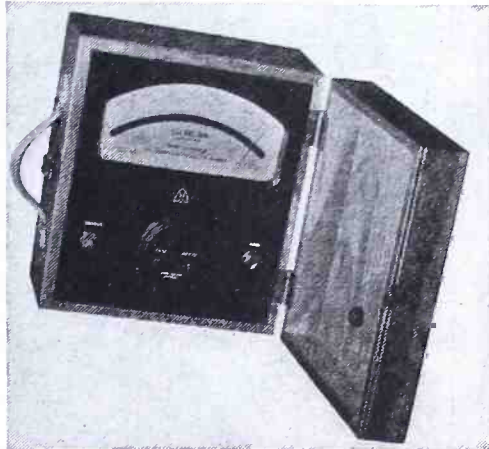

### BEE TERMINAL BLOCKS

Solderless, wire-to-wire Bee terminal blocks with slotted-channel binding-post studs, are being produced by L. S. Brach Manufacturing Corporation, Newark 4, N. J. One type, series A-200, has terminal posts staggered in V formations. In another type, series A-300, terminals are set straight in line.

Wires are held in channel between a top clamp or shoe built into the nut, and a lower clamp or shoe which is secured to the base.

Manufacturer claims that average contact resistance of terminal block equals .00031 ohm after 90 hours salt spray.

Block is said to be coated with a hard, moisture-proof, arc-resistant film which contains a fungicidal substance. Base is made of laminated phenolic. Blocks are made under license from the Buchanan Research Laboratories, Inc.

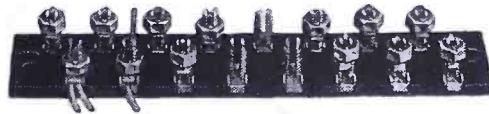

### ROWE MILLISECOND METER

An elapsed milliseconds meter, type MM100, that measures, electronically, small periods of elapsed time directly in milliseconds on a linear scale meter, has been developed by Rowe Radio Research Laboratory Co., 2422 North Pulaski Road, Chicago. The start and finish of the period to be measured is made to initiate and terminate operation of the unit by various mechanical, electrical or photoelectronic means. Start of the period causes the meter to rise and termination stops the meter, at which position it remains for taking the reading.

Range is 100 milliseconds. Other ranges can be had covering both higher and lower elapsed periods.



### N. A. PHILIPS SPECTROMETER

A Geiger-counter x-ray spectrometer has been announced by North American Philips Co., Inc., 100 East 42 Street, N. Y. City.

The spectrometer utilizes a Geiger-Muller tube to measure the intensity and position of interference lines which are encountered in x-ray diffraction analysis work.

# SIGNAL LIGHT

*visible from  
all  
angles*

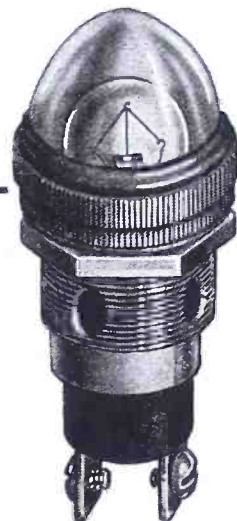

## Gothard SERIES 1600 PILOT LIGHTS

● represent a decided advance in Pilot Light design and function. They are particularly adapted to indicate "Current ON" for industrial machines. These Gothard Lights are equipped with special conical lens that are molded with tiny hemispheres on the inner surface for maximum diffusion of light—you see the light from all angles. The shape of these lenses permits the lamp to mount well forward of the panel. Lamps removable from front. Model 1600—for 115 volt candelabra lamps; Model 1604—for single contact, bayonet base lamps and Model 1605—for double contact, bayonet base lamp. Jewel colors: red, green, amber, blue, opal and clear. Request new Gothard catalog on these and other models.

*Gothard*

**MANUFACTURING COMPANY**

1335 NORTH NINTH STREET  
SPRINGFIELD, ILLINOIS

Canadian Distributor: William F. Kelly Company

1207 Bay Street, Toronto 5, Ontario.

Export Division: 25 Warren Street,  
New York 7, N. Y.

Cables: Simontrice, New York

A STEADY SOURCE OF ALL  
ELECTRONIC  
EQUIPMENT

**TERMINAL RADIO CORP.**

Telephone: WOrth 2-4416

85 CORTLANDT ST., NEW YORK, N. Y.

*Your Plant*

FOR ACTION  
PHONE! WIRE! WRITE  
BULLETINS AND CATALOGS ON REQUEST

# AUDAX

RELAYED-FLUX  
*Microdyne*

Long before this war began  
AUDAX Pickups were in

## SELECTIVE SERVICE

Since pickups first became important commercially, the distinguished products of AUDAX have been SELECTED wherever and whenever the requirements were exacting.

Today AUDAX magnetically powered pickups are SELECTED for War contracts that demand the highest standards of performance . . . irrespective of climatic variations or severe handling.

Our stern peacetime standards, maintained for so many years, have proven comfortably adequate to meet government specifications.

The sharp, clean-cut *facsimile* reproduction of MICRODYNE is a marvel to all who have put it to the only test that really matters . . . the EAR TEST.

**AUDAK COMPANY**  
500-C Fifth Ave., New York 18, N. Y.

Creators of High Grade Electrical  
and Acoustical Apparatus Since 1915

Send for your copy of our informative  
"PICK-UP FACTS"

★ BUY  
WAR BONDS

"The Standard by Which Others  
Are Judged and Valued"



## ADVERTISERS IN THIS ISSUE

COMMUNICATIONS—NOVEMBER, 1944\*

THE ACME ELECTRIC & MFG. CO. . . . .	56	HOWARD B. JONES CO. . . . .	84
Agency: Scheel Adv. Agency		Agency: Merrill Symonds, Advertising	
AEROVOX CORPORATION . . . . .	93	KARP METAL PRODUCTS CO. . . . .	16
Agency: Austin C. Lescarboura & Staff		Agency: Shappe-Wilkes Inc.	
AIRCRAFT ACCESSORIES CORP. . . . .	4, 5	THE JAMES KNIGHTS CO. . . . .	67
Agency: Potts-Turnbull Co.		Agency: Turner Adv. Agency	
AMALGAMATED RADIO TELEVISION CORP. . . . .	92	KURMAN ELECTRIC CO. . . . .	96
Agency: Shappe-Wilkes Inc.		Agency: H. J. Gold Co.	
AMPEREX ELECTRONIC CORP. . . . . Inside Front Cover		THE LANGEVIN CO. . . . .	1
Agency: Shappe-Wilkes Inc.		Agency: Terrill Belknap Marsh Associates	
AMPERITE CO. . . . .	94	LENZ ELECTRIC MFG. CO. . . . .	53
Agency: H. J. Gold Co.		Agency: Triangle Adv. Agency, Inc.	
VICTOR J. ANDREW CO. . . . .	90	LEWYTT CORPORATION . . . . .	13
Agency: Burton Browne, Advertising		Agency: Moser & Cotins N. Y. C. Corp.	
THE ANSONIA ELECTRIC CO. . . . .	31	LITTELFUSE, INC. . . . .	93
Agency: Albert Frank-Guenther Law, Inc.		Agency: Merrill Symonds, Advertising	
ARPIN MFG. CO. . . . .	56	McELROY MFG. CORP. . . . .	96
Agency: Gallard Adv. Agency		Agency: Shappe-Wilkes Inc.	
THE AUDAK CO. . . . .	98	MACHLETT LABORATORIES, INC. . . . .	9
Agency: Hart Lehman, Advertising		Agency: St. Georges & Keyes, Inc.	
AUDIO DEVELOPMENT CO. . . . .	85	MEASUREMENTS CORPORATION . . . . .	86
Agency: Turner Adv. Agency		Agency: Frederick Smith	
BARKER & WILLIAMSON . . . . .	57	MERIT COIL & TRANSFORMER CORP. . . . .	86
Agency: The Harry P. Bridge Co.		Agency: Ross Llewellyn, Inc.	
REX BASSETT, INC. . . . .	78	MICARTA FABRICATORS INC. . . . .	87
Agency: Art Kell & Associates		Agency: Sander Rodkin	
BENDIX RADIO DIV. BENDIX AVIATION CORP. . . . .	11	JAMES MILLEN MFG. CO., INC. . . . .	76
Agency: MacManus John & Adams, Inc.		MONARCH MFG. CO. . . . .	80
BIRTCHEER CORPORATION . . . . .	74	Agency: Duane Wanamaker, Advertising	
Agency: Robert F. Dennis, Inc.		MYCALEX CORPORATION OF AMERICA . . . . .	25
BLILEY ELECTRIC CO. . . . .	80	Agency: Rose-Martin, Inc.	
Agency: Hardy, Advertising		NATIONAL UNION RESEARCH CORPORATION . . . . .	23
BOONTON RADIO CORP. . . . .	82	Agency: Hutchins Adv. Co., Inc.	
Agency: Frederick Smith		NORTH AMERICAN PHILIPS CO., INC. . . . .	17
L. S. BRACH MFG. CORP. . . . .	54	Agency: Erwin, Wasay & Co., Inc.	
Agency: United Adv. Agency		OHMITE MFG. CO. . . . .	22
BREEZE CORPORATIONS . . . . .	18	Agency: Henry H. Teplitz, Advertising	
Agency: Burke Dowling Adams		O'NEIL-IRWIN MFG. CO. . . . .	85
BURGESS BATTERY CO. . . . .	79	Agency: Foulke Agency	
Agency: Howard H. Monk & Associates		PETERSEN RADIO CO. . . . .	96
BURSTEIN-APPLEBEE CO. . . . .	85	PREMAX PRODUCTS DIV. CHISHOLM-RYDER CO., INC. . . . .	72
Agency: Frank E. Whalen Adv. Co.		Agency: Norton Adv. Service	
CAMBRIDGE THERMIONIC CORP. . . . .	37	RADIO CORPORATION OF AMERICA . . . . .	43
Agency: Walter B. Snow & Staff		Agency: Kenyon & Eckhardt, Inc.	
CANNON ELECTRIC DEVELOPMENT CO. . . . .	75	RADIO RECEPTOR CO., INC. . . . .	69
Agency: Dana Jones Co.		Agency: Shappe-Wilkes Inc.	
CENTRAL RADIO LAB. . . . .	14	RAYTHEON MFG. CO. . . . .	29
Agency: Gustav Marx Adv. Agency		Agency: Burton Browne, Advertising	
CINAUDAGRAPH SPEAKERS, INC. . . . .	94	REMLER CO., LTD. . . . .	77
Agency: Michael F. Mayker		Agency: Albert A. Drennan	
COLE STEEL EQUIPMENT CO. . . . .	73	THE ROLA CO., INC. . . . .	10
Agency: Ehrlich & Neuwirth		Agency: Foster & Davies, Inc.	
COMMUNICATIONS CO., INC. . . . .	81	RUBY CHEMICAL CO. . . . .	96
Agency: Moran & Webb		Agency: Harry M. Miller, Inc.	
CONCORD RADIO CORP. . . . .	64	SHURE BROTHERS CO. . . . .	20
Agency: Shappe-Wilkes Inc.		Agency: Henry H. Teplitz, Advertising	
CONTINENTAL ELECTRIC CO. . . . .	83	SNYDER MFG. CO. . . . .	66
Agency: Duane Wanamaker, Advertising		Agency: Philip Klein Advertising Agency	
CORNISH WIRE CO. . . . .	97	SPERRY GYROSCOPE CO., INC. . . . .	15
Agency: Hart Lehman, Advertising		Agency: Young & Rubicam	
CRYSTAL PRODUCTS CO. . . . .	63	SPERTI, INC. . . . .	27
Agency: R. J. Potts-Calkins & Holden		Agency: Stockton-West-Burkhart, Inc.	
D-X CRYSTAL CO. . . . .	90	SPRAGUE ELECTRIC CO. . . . .	61
Agency: Michael F. Mayker		Agency: The Harry P. Bridge Co.	
DeJUR-AMSCO CORPORATION . . . . .	12	STANDARD WINDING CO. . . . .	76
Agency: Shappe-Wilkes Inc.		Agency: Sternfield-Godley, Inc.	
DIAL LIGHT COMPANY OF AMERICA . . . . .	91	SURPRENANT ELECTRICAL INSULATION CO. . . . .	95
Agency: H. J. Gold Co.		Agency: G. Jerry Spaulding, Inc.	
DOOLITTLE RADIO INC. . . . .	41	SYLVANIA ELECTRIC PRODUCTS INC. . . . .	3
Agency: Henry H. Teplitz, Advertising		Agency: Arthur Kudner, Inc.	
DRAKE MFG. CO. . . . .	88	TECH LABORATORIES . . . . .	71
Agency: The Vanden Co.		Agency: Lewis Adv. Agency	
ALLEN B. DUMONT LABORATORIES, INC. . . . .	24	THE TELEX PRODUCTS CO. . . . .	65
Agency: Austin C. Lescarboura & Staff		Agency: Erwin, Wasay & Co. of Minnesota	
EITEL-McCULLOUGH, INC. . . . .	19	TERMINAL RADIO CORP. . . . .	97
Agency: L. C. Cole, Advertising		Agency: Charles Brunelle	
ELECTRONIC LABORATORIES, INC. . . . .	49	THERMADOR ELECTRIC MFG. CO. . . . .	59
Agency: Burton Browne, Advertising		Agency: John H. Riordan Co.	
ELECTRO-VOICE MFG. CO., INC. . . . .	89	THOMAS & SKINNER STEEL PRODUCTS CO. . . . .	72
Agency: Shappe-Wilkes Inc.		Agency: The Caldwell-Baker Co.	
FEDERAL TELEPHONE & RADIO CORP. . . . .	55	GEORGE S. THOMPSON CORP. . . . .	74
Agency: Marschalk & Pratt		Agency: Robert F. Dennis, Inc.	
FEDERAL TELEPHONE & RADIO CORP. . . . .	88	THORDARSON ELECTRIC MFG. CO. . . . .	76
Agency: Commerce Agency, Inc.		Agency: Duane Wanamaker, Advertising	
A. W. FRANKLIN MFG. CO. . . . .	50	U. S. TREASURY DEPT. . . . .	28
Agency: Sam J. Gallay		UNITED TRANSFORMER CORP. . . . .	30
GENERAL INSTRUMENT CORP. . . . .	7	Agency: Shappe-Wilkes Inc.	
Agency: H. W. Fairfax Agency, Inc.		UNIVERSAL MICROPHONE CO. . . . .	26, 78
GENERAL RADIO CO. . . . . Inside Back Cover		Agency: Ralph L. Power Agency	
GOTTHARD MFG. CO. . . . .	97	UNIVERSITY LABORATORIES . . . . .	74
Agency: Merchandising Advertisers		Agency: George Homer Martin	
HALLICRAFTERS, INC. . . . .	8	VALPEY CRYSTAL CORP. . . . .	52
Agency: Burton Browne, Advertising		Agency: Cory Snow, Inc.	
HAMMARLUND MFG. CO., INC. . . . .	32	WILLIAM T. WALLACE MFG. CO. . . . .	92
Agency: Roeding & Arnold, Inc.		Agency: Michael F. Mayker	
HARVEY RADIO CO. . . . .	70	WARD-LEONARD ELECTRIC CO. . . . .	85
Agency: Shappe-Wilkes Inc.		Agency: E. M. Freystadt Associates, Inc.	
HARVEY RADIO LABS., INC. . . . .	21	WESTERN ELECTRIC CO. . . . .	76
Agency: Walter B. Snow & Staff		Agency: Deutsch & Shea Adv. Agency, Inc.	
THE HARWOOD CO. . . . .	47	WESTINGHOUSE ELECTRIC & MFG. CO. . . . .	Back Cover
Agency: John H. Riordan Co.		Agency: Fuller & Smith & Ross, Inc.	
HEWLETT-PACKARD CO. . . . .	6	ZOPHAR MILLS, INC. . . . .	56
Agency: L. C. Cole, Advertising		Agency: J. G. Proctor Co., Inc.	
HIGGINS INDUSTRIES, INC. . . . .	91		
HIPOWER CRYSTAL CO. . . . .	85		
Agency: Turner Adv. Agency			
THE HOPP PRESS, INC. . . . .	97		
Agency: Gallard Adv. Agency			
HOWARD MFG. CORP. . . . .	66		
Agency: Bozell & Jacobs			
HYTRON CORPORATION . . . . .	45		
Agency: Henry A. Loudon—Advertising			
INSULINE CORPORATION OF AMERICA . . . . .	82		
Agency: H. J. Gold Co.			
E. F. JOHNSON CO. . . . .	72, 78, 95		
Agency: David, Inc.			

\*Due to paper restrictions several advertising pages had to be omitted from this issue.

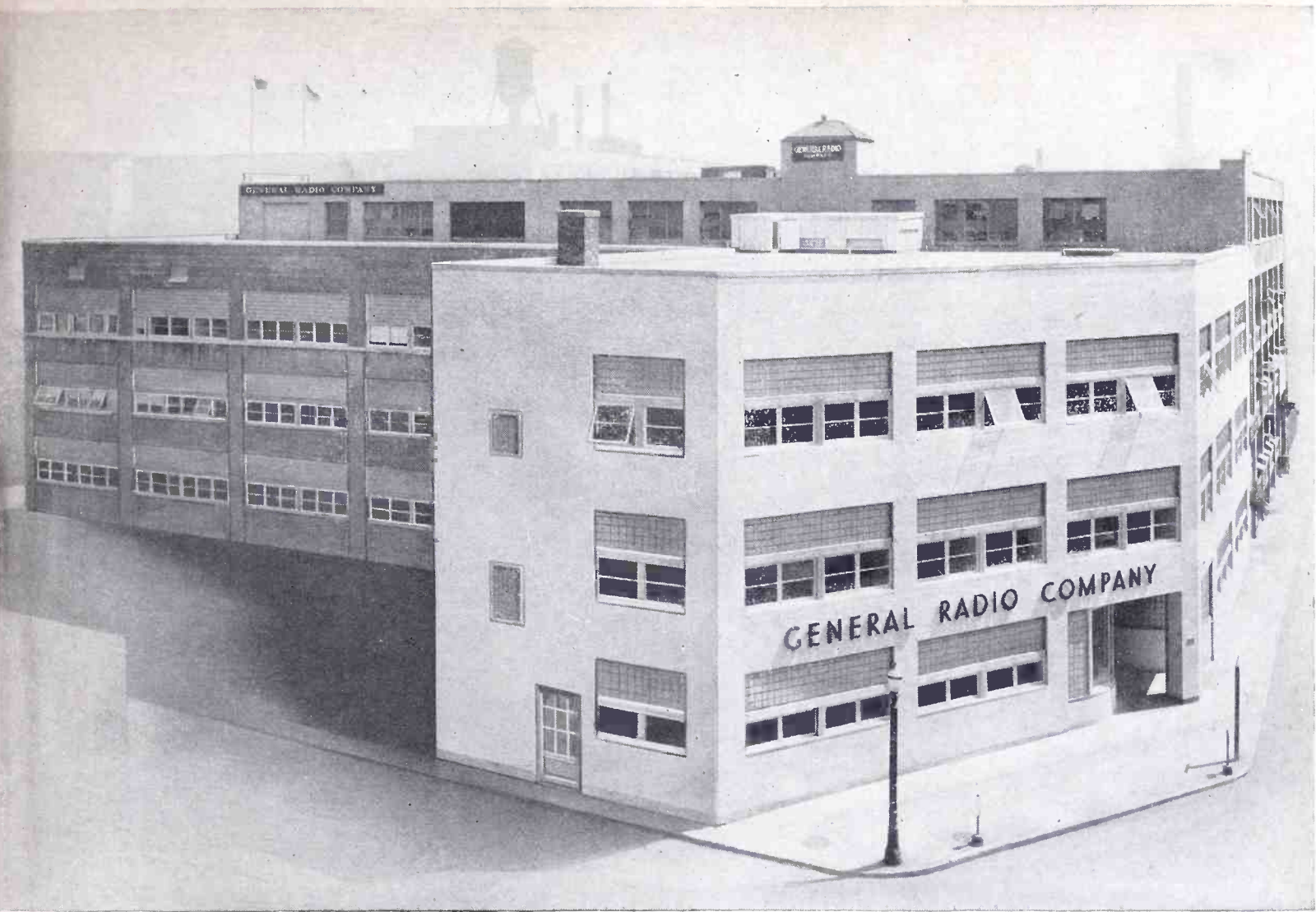

## JUST AROUND THE CORNER

● LATELY, persons corresponding with us have noted a new address . . . 275 Massachusetts Avenue. We've moved our engineering and general business offices into a remodeled building at this location. It's just around the corner from 30 State Street, which is still ours, and which is now devoted exclusively to manufacturing.

For a long time we have felt the need for rearranging our space; for one thing we have been badly cramped in the shop; and our engineering department has been spread over several floors and mixed up with many other activities.

The new building, which is connected by ramps on all floors with the older one, provides about 30 per cent more manufacturing space, and allows all of the engineering department to be on one floor.

Under pressure of the war we have expanded our output in several ways. We have let out the manufacture of several instruments to sub-con-

tractors; we have turned over the designs, drawings and models of several instruments to other manufacturers for their exclusive use; we have rented considerable extra space in two outside buildings, in one of which we have contracted for a large number of war-time workers under our own foremen.

After the war when the armed guards have left us, we hope that you will come to see our new laboratories and offices. In the meantime we continue to devote our energies to filling war orders for electronic laboratory test equipment.

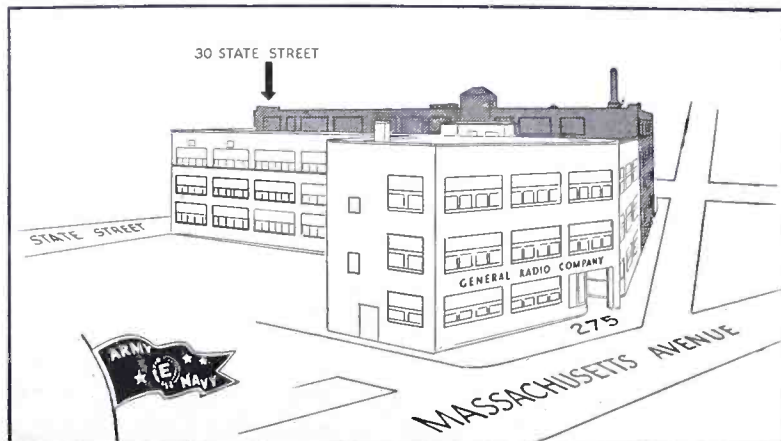

**VARIAC**



MADE ONLY BY

**GENERAL RADIO COMPANY**

Cambridge 39, Mass.

NEW YORK  
CHICAGO  
LOS ANGELES

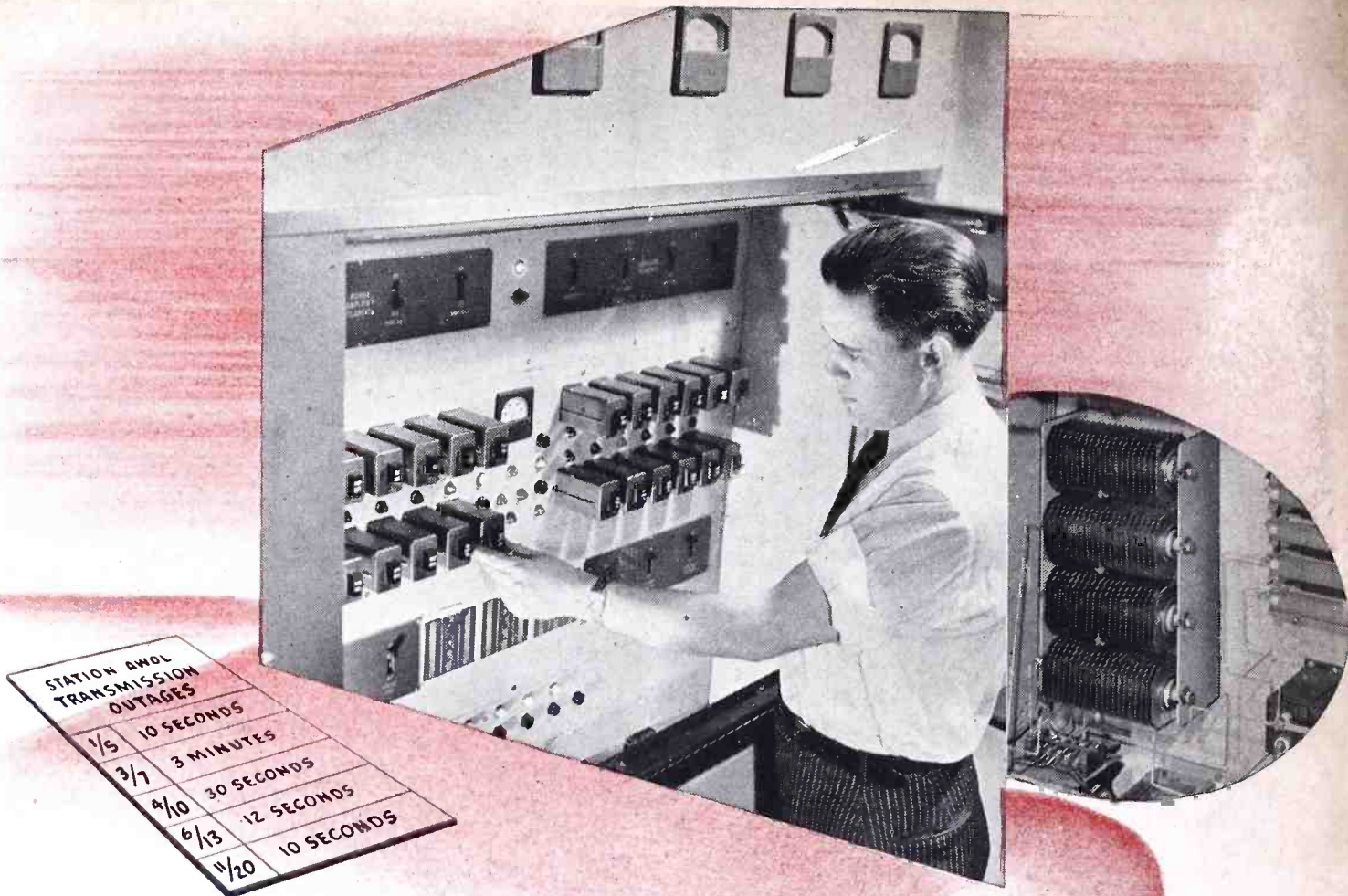

STATION AMOL TRANSMISSION OUTAGES	
1/5	10 SECONDS
3/7	3 MINUTES
4/10	30 SECONDS
6/13	12 SECONDS
11/20	10 SECONDS

**CONSIDER** *Continuity of Operation*  
**WHEN YOU SELECT A NEW TRANSMITTER**

Off the air, right in the middle of a program—that's the nightmare of operating a radio station. That's when seconds seem like hours, and minutes like eternities. As though you didn't know!

Westinghouse Transmitters have been designed to cut program outage down to an almost unbelievable point. For example:

1. *Indicator Lights* show at a glance which circuit suffered an overload—even though the transmitter has returned to the air... making circuit checkup easy.
2. *Conservative Operation of All Tubes*—greatly increases reliability... lengthens tube life.
3. *Air-Cooled Tubes*—eliminate complicated and unreliable water cooling equipment.
4. *Surgeproof Metal Rectifiers* eliminate low voltage rectifier failures.
5. *Tube Life Meter* indicates the end of reliable tube life.

6. *Circuit Breakers* supply full overload and undervoltage protection automatically reducing length of outage.

We'll gladly give you complete information on these features, as well as other important advantages of Westinghouse Transmitters, such as: **Low Operating Cost, Simplicity of Control, High Fidelity Signals, Ease of Maintenance.**

**PLACE YOUR ORDER NOW  
 FOR YOUR POSTWAR TRANSMITTER**

By placing your order today for a Westinghouse Transmitter, you assure yourself of the fastest possible delivery following the lifting of wartime manufacturing restrictions. We are scheduling deliveries in the sequence in which orders are received. For details, write Westinghouse Electric & Mfg. Company, Dept. 1NB, P. O. Box 868, Pittsburgh 30, Pa.

J-08079

**Westinghouse RADIO DIVISION**  
 PLANTS IN 25 CITIES... OFFICES EVERYWHERE



**A M • E L E C T R O N I C S • F M**