

COMMUNICATIONS

including
**TELEVISION
ENGINEERING**

MAY 24 REC'D

MAY
1940

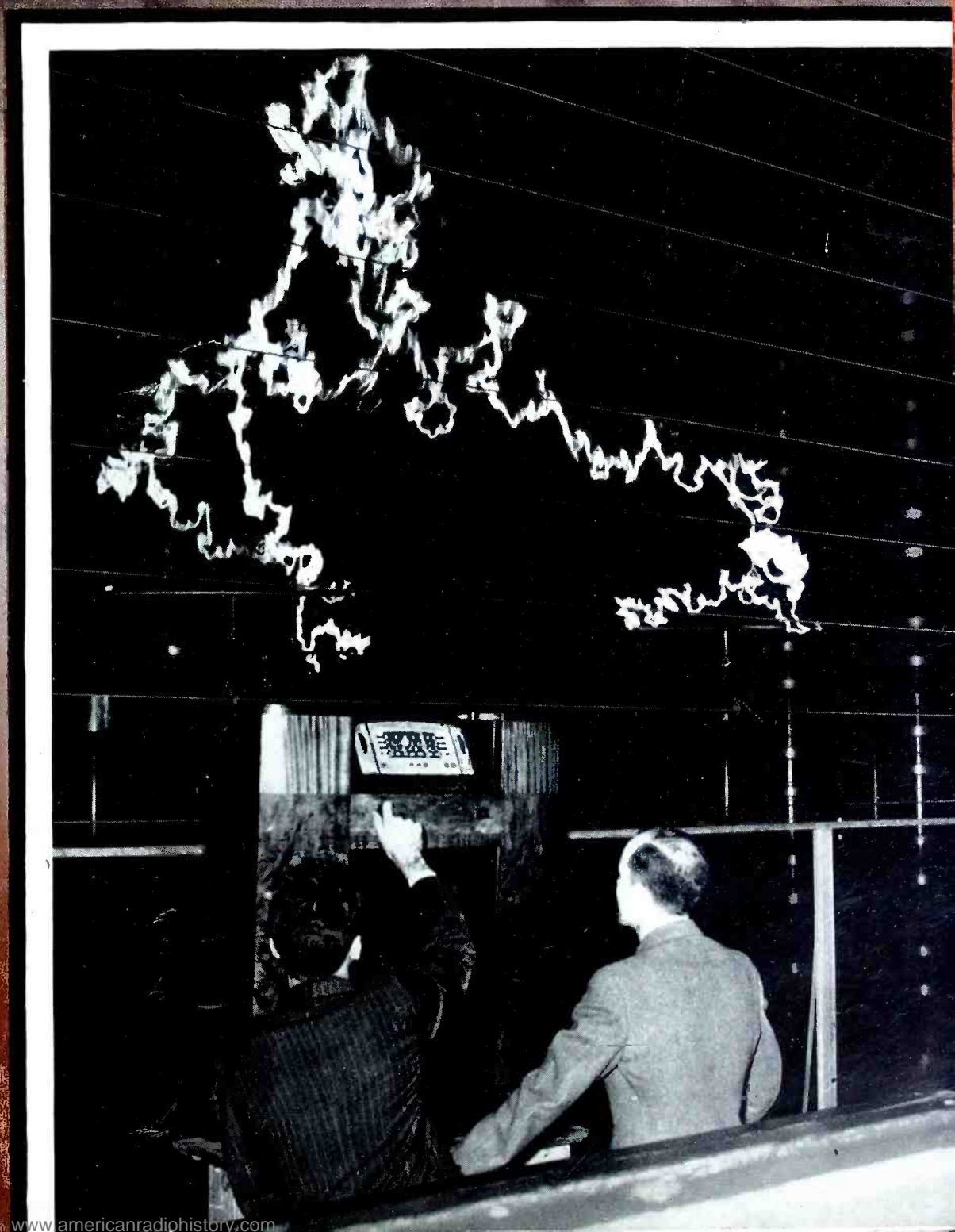

The IDEAL in a high FOR FREQUENCY MODULATION



Products of AmpereX Engineering

Power Transmitting Tube

TELEVISION and BROADCASTING

10 K.W. up to 30 megacycles in telegraphy service
70% EFFICIENCIES and better at 40 to 50 megacycles
5000 Watts per pair in Broadcast Band (*FCC approved)

Frequency Modulation and Television — so long in the offing — have finally arrived and they are accomplished facts. However, in their train have come such a multiplicity of intricate engineering problems and a complexity of design problems as to literally swamp the broadcast engineer and equipment designer.

One of the most perplexing of these is the question of tubes. High power at Ultra High Frequencies is the order of the day and the engineer and designer naturally turn to water cooled tubes. Obviously, though, the water cooled tube with its cumbersome associated equipment is not the ideal generator of Ultra High Frequencies, nor does it lend itself to simplicity and efficiency in circuit design.

With the full realization of the deficiencies of existing tubes in mind, the Amperex Engineering Staff has designed and perfected a series of high power all-glass air-cooled tubes whose efficiencies at ultra high frequencies are truly startling and which are also highly desirable substitutes for water-cooled and radiator-cooled tubes in normal broadcast transmitters.

Some of their outstanding characteristics follow:

- All Glass — Air Cooled.
- Economical in Operation.
- Simplicity in Equipment Design.
- Pure Tungsten Filament
(for reliability of operation and long life)
- High Grid to Plate Transconductance.
- Extra Low Interelectrode Capacitance.
- Low Lead Resistance.
- 5 K.W. output per pair at 40 to 50 megacycles with 70% efficiency and better.
- 10 K.W. and better in telegraphy service at all frequencies up to 30 megacycles.

PRICE each \$300.00

AMPEREX ELECTRONIC PRODUCTS, Inc.
79 WASHINGTON STREET • BROOKLYN, NEW YORK
ATLANTA • CHICAGO • SEATTLE • LOS ANGELES

• **HF3000 HIGH POWER TRANSMITTING TRIODE** is characterized by a Balanced Positive Grid Plate and Grid Current characteristics for minimized natural distortion in plate modulated service. High Plate to Grid Transconductance—Low lead resistance.

Characteristics	21-22 Volts
Filament Voltage	40.5 Amps.
Filament Current	16
Amplification Constant	10,000 Volts
Maximum Ratings	1.25 Amps.
D.C. Plate Voltage	2.5 K.W.
D.C. Plate Current	
Typical Performance Capabilities	
Plate Modulated Power Amplifier output	4000 watts
Linear R.F. Power Amplifier output	1000 watts
Unmodulated or F.M. Amplifier output	
D. C. Plate Voltage	6000 at 40 MC
D. C. Plate Voltage	5000 at 50 MC
D. C. Plate Voltage	4000 at 60 MC
D. C. Plate Voltage	4000 at 60 MC
*FCC Approval for high level or plate modulation 2500 watts	

• **AB3100 CLASS AB MODULATOR**
 An exceptionally high pureveance plus a low output resistance permit the use of this tube as a class AB modulator for audio powers as high as 6 K.W. out of a pair of tubes and sufficient audio power for the plate modulation of the final stage of a 5 K.W. Broadcast Transmitter at a plate voltage as low as 5000 volts. True AB operation minimizes driving requirements and distortion.

Characteristics	15. Volts
Filament Voltage	58. Amperes
Filament Current	5. Amperes
Emission	6
Amplification Constant	10,000 Volts
Maximum Ratings	1 Ampere
Plate Voltage	2 K.W.
D.C. Plate Current	
Typical Performance	
Class A Amplifier or Modulator	600 watts
Output	

• **ZB3200—A low distortion ZERO BIAS CLASS B MODULATOR** of relatively low driving power requirements. A high Amplification Constant plus a correspondingly high plate resistance provide extraordinary abuse tolerance for hard usage in commercial telegraphy service.

Characteristics	21-22 Volts
Filament Voltage	40.5 Amps.
Filament Current	85
Amplification Constant	10,000 Volts
Maximum Ratings	1.25 Amperes
D.C. Plate Voltage	2.5 K.W.
D.C. Plate Current	
Plate Dissipation per tube	8,000 watts
Typical Performance	
Class B Zero Bias Modulator	1,000 watts
Output 2 Tubes	
Class B Linear R.F. Power	
Amplifier	
Class C Telegraphy	8000 at 30 MC
D.C. Plate Voltage	6000 at 40 MC
D.C. Plate Voltage	5000 at 50 MC
D.C. Plate Voltage	6000 watts
	4000 watts
	3000 watts

• Contents •

COVER ILLUSTRATION

A General Electric frequency-modulation receiver undergoing listening tests while subjected to million-volt lightning discharges in Steinmetz Hall, New York World's Fair.

- 5 AIRCRAFT RADIO VIBRATION By L. B. Hallman, Jr.
- 8 VOLTAGE DIVIDERS FOR EXTENDED FREQUENCY RANGES By F. Alton Everest
- 10 SATELLITE STUDIO EQUIPMENT By Grant S. Feikert
- 12 MARINE TELEPHONES FOR SMALL BOATS
By S. Gordon Taylor
- 13 ANTENNAS AND TRANSMISSION LINES AT THE EMPIRE STATE TELEVISION STATION
By N. E. Lindenblad
- 24 OVER THE TAPE
- 24 CORRECTION NOTICE
- 25 IRE CONVENTION PROGRAM
- 26 THE MARKET PLACE
- 32 INDEX OF ADVERTISERS

• Editorial Comment •

FREQUENCY modulation seems destined to play an important part in police radio communications. In this connection f-m transmission seems to possess three advantages over conventional systems: (1) comparative freedom from noise, (2) minimum interference between properly spaced stations on the same frequency, and (3) better overall reception with less fading caused by steel bridges, elevated structures, and the like.

Recent demonstrations employing low-power transmitters installed in automobiles confirmed the above opinions. With increasing interest in the subject, it seems likely that several state police systems will employ f-m before the end of the year.

IN line with our usual policy of announcing convention dates in this section, we should like to call attention to the following gatherings:

Radio Parts National Trade Show, June 11-14, Hotel Stevens, Chicago, Ill.

Institute of Radio Engineers, June 27-29, Hotel Statler, Boston, Mass.

National Association of Broadcasters, August 4-7, St. Francis Hotel, San Francisco, Calif.

Pacific Coast Convention IRE-AIEE, August 28-30, Los Angeles, Calif.

Rochester Fall Meeting, November 11-13, Hotel Sagamore, Rochester, N. Y.

National Police Communication Conference, December 2-5, Orlando, Florida.

Details on most of these gatherings will appear in later issues of COMMUNICATIONS.

IT is expected that the FCC will take early action on both television and frequency modulation. Apparently the television question is receiving the immediate attention of the Commission and a lengthy report is anticipated at an early date, probably this month. It is to be hoped that the f-m report will also be issued without too much delay. The radio industry is anxiously awaiting these decisions.

Copyright 1940, Bryan Davis Publishing Co., Inc.

BRYAN S. DAVIS
President

JAMES A. WALKER
Secretary

Published Monthly by the
BRYAN DAVIS PUBLISHING CO., Inc.

19 East 47th Street
New York City

New York Telephone: PLaza 3-0483

PAUL S. WEIL
Advertising Manager

A. GOEBEL
Circulation Manager

Chicago Office—608 S. Dearborn Street
Telephone: Wabash 1903



Wellington, New Zealand—Te Aro Book Depot
Melbourne, Australia—McGill's Agency

Entered as second-class matter October 1, 1937, at the Post Office at New York, N. Y., under the act of March 3, 1879. Yearly subscription rate: \$2.00 in the United States and Canada, \$3.00 in foreign countries. Single copies: twenty-five cents in United States and Canada, thirty-five cents in foreign countries.

YOUR TUBE DOLLAR-- IS IT INVESTED---OR SPENT?

TO BE invested, every dollar you put into transmitting tubes should provide:

- 1—dependable, economical performance today
- 2—research to assure even better tubes tomorrow

If the tubes in your transmitter are marked "General Electric" your tube dollar is invested, because G-E transmitting tubes year by year will give you improved performance, and at the lowest possible operating cost.

The GL-857B is a noteworthy example—a tube whose history is another story of G-E achievement:

G-E Engineers . . .

- developed the hot-cathode mercury-vapor rectifier.
- built the first high-voltage mercury-vapor rectifiers, which were soon accepted as standard throughout the industry.
- introduced the 857, and later the new 857 which reduced arc-backs, cut voltage drop and power loss between electrodes, and gave longer life and greater dependability.
- produced a more efficient cathode that cut filament power in half.
- developed the first accurate rectifier emission test, which assured even greater dependability in G-E built tubes.
- designed a new, rigid filament structure, which greatly increased cathode life.

Bulletin GEA-3315A gives technical information and prices on the complete G-E transmitting tube line. Get one from the nearest G-E Office, or write direct to General Electric, Radio and Television Dept., Schenectady, N. Y.

NOW—G.E. announces the GL-266B, a high-power, high-voltage mercury-vapor rectifier—interchangeable with the 266B—and incorporating all the advantages of the GL-857B. Available soon.

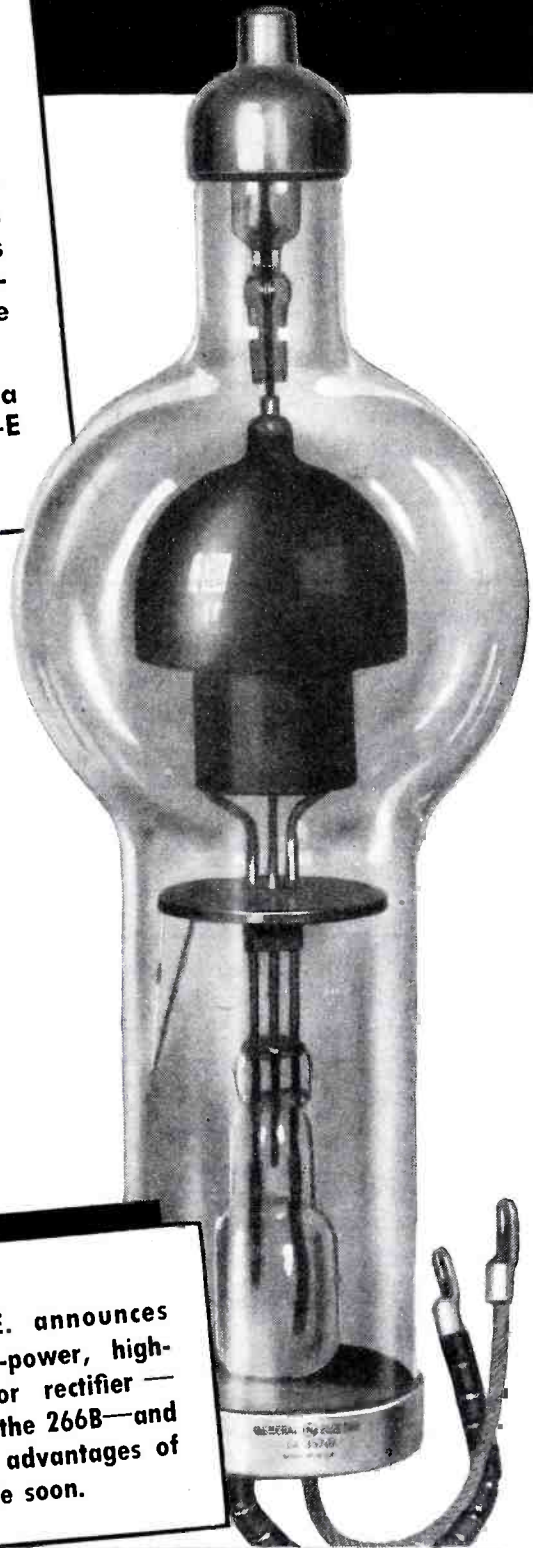

GENERAL  ELECTRIC

161-3



LENZ *Presents* a NEW and IMPROVED DIAL LIGHT SOCKET

Voltage Breakdown between contacts—1200 Volts.
Voltage Breakdown to ground—5000 Volts.

Bakelite Shell is recessed for contacts, which cannot be pushed or pulled out of position.

Heavy wall Bakelite Shell.

Brackets on grounded type socket welded to shell preventing interference due to vibration.



Tensile strength of leads and connections far in excess of requirements.

Center contact mounted so that it cannot protrude from shell and short on chassis when lamp is removed.

Lug on contact fits in groove in shell so that contact cannot be turned or twisted when inserting lamp.

A variety of different mounting bracket styles available, suitable for practically any mounting.

● *Complete Wire and Socket Assembly Accepted in Radio Receivers listed by Underwriters Laboratories.*

The superiority of the new Lenz Dial Light Socket, both electrically and mechanically is apparent with even the most casual inspection.

But even with its obvious superiority the use of the New Lenz Dial Light Socket will not add to the cost of your radio chassis. Samples will be gladly submitted upon receipt of specifications. Lenz Dial Light Sockets are made in both the two wire insulated type with bakelite shell and the single wire grounded type with metal shell.



**LENZ ELECTRIC
MANUFACTURING CO.**
1751 N. Western Ave., Chicago, Illinois

ENJOYING ITS 35TH YEAR OF SUCCESSFUL BUSINESS

AIRCRAFT RADIO VIBRATION

The mechanical insulation of radio equipment against aircraft vibration

I—The Problem

VIBRATION is one of the fundamental problems in aircraft design. Because of the necessity for making every part of the aircraft structure as light and as compact as possible, vibration originating in the engine and propeller is quite readily transmitted to every section of the ship. Also, vibration of considerable amplitude often originates with aerodynamic disturbances occurring when the ship is rapidly losing altitude or otherwise maneuvering in such a manner as to unbalance the forces between the air and various portions of the airplane structure. Shock caused by taxing over rough ground is often severe as are also impulses set up due to the impact with the ground on landing.

Such vibratory disturbances shorten the life of radio equipment by weakening the internal structure of vacuum tubes, by making precise fixed adjustments difficult to maintain and by placing greater stresses on all soldered connections, machine-screw assemblies and supporting members. Many of these difficulties can be overcome by heavier and more rigid designs. Such designs are expensive, however, and as it is usually necessary to keep weight down as much as possible, it is better engineering practice to use lighter, simpler construction and effectively insulate the radio equipment against vibrations that might be encountered in the aircraft.

It is with the design of such insulating or vibration-absorbing structures that this paper is concerned. If an insulating mounting is to be of the greatest value it must be properly designed. It is not always true that just any type of vibration-absorbing structure is better than none at all, and it is quite likely that an improperly or carelessly designed insulating mounting will do more harm than good.

By **L. B. HALLMAN, Jr.**

Aircraft Radio Lab.
Wright Field

II—Translatory Vibration

The problem presented by pure translatory vibration may be understood from a study of the simple structure shown in Fig. 1. Here we have a mass mounted upon a vibrating structure and separated from it by an isotropic elastic medium. We assume a vibratory motion to be imparted to the mounting structure by means of a force F acting in the direction S . The purpose of the elastic medium, or compliance, is to insulate the mass from the vibrating structure in such a manner that the mass will remain practically stationary

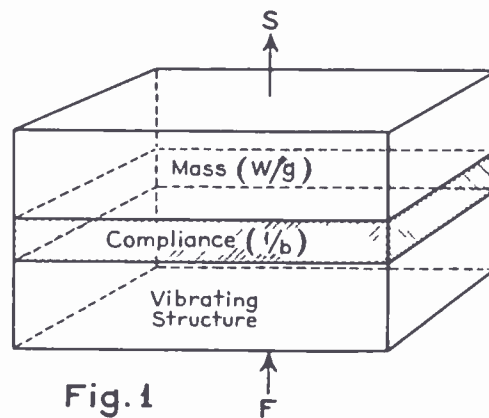

Fig. 1

even though the structure upon which it is mounted is vibrating. It is our problem to determine the properties of the compliance required to accomplish this. The mass represents the radio equipment we desire to mount and insu-

late. The vibrating structure is the airplane fuselage.

The theoretical and practical analysis of this type of structure, regarded as a dynamical system having one degree of freedom, has been thoroughly covered as it applies to airplane instrument board vibration^{1, 2, 3}, and in a general way it has been expounded in textbooks on vibration and vibration engineering. However, none of the systems analyzed in these references are directly applicable to the designs of suitable vibration-absorbing assemblies for radio equipment. We shall review the classic analysis briefly here because it is necessary to the clear understanding of our particular problem and its solution. We neglect, for the moment, any possible rotational vibration and assume that the effective force resulting from the vibrating structure may be represented by $F = F_0 \sin \omega t$, where $\omega = 2\pi f$. That this assumption is justified, follows from the fact that any periodic force may, by a Fourier analysis, be represented by a fundamental and a series of harmonic sinusoidal terms. If we succeed in insulating against the fundamental, the harmonic terms can cause no trouble, since, in a properly designed assembly, they will be attenuated to a greater degree than the fundamental.

Opposing this applied force we have:

(1) The force due to the accelerated mass $= (W/g)d^2s/dt^2$; where W is the weight of the mass and g is the acceleration of gravity.

(2) The force due to friction or viscous damping $= C ds/dt$; where C is the damping constant of the structure.

(3) The force due to the elastic element $= bs$; where b is the stiffness in the direction of applied stress—Hooke's law assumed. Adding the counter forces (1), (2) and (3), and equating them to the applied force we have:

$$(W/g)d^2s/dt^2 + C ds/dt + bs = F_0 \sin \omega t,$$

(1) Stephen J. Zand, "A Study of Airplane and Instrument-Board Vibrations," *S. A. E. Journal*, Vol. 29, 1931, p. 263.
 (2) Stephen J. Zand, "Vibration of Instrument Boards and Airplane Structures," *S. A. E. Journal*, Vol. 31, 1932, p. 445.
 (3) S. J. Zand and L. N. Swisher, "Anti-Vibration Mounting of Airplane Instruments," *Bulletin 101C*, Lord Manufacturing Company.
 (4) S. Timoshenko, "Vibration Problems in Engineering," 2nd ed., p. 38, D. Van Nostrand Company, Inc.

$$\text{or } d^2s/dt^2 + 2n ds/dt + p^2s = q \sin \omega t \dots\dots\dots (1)$$

Where

$$n = gC/2W; p^2 = gb/W; q = gF_0/W.$$

The general solution of (1) is,⁴

$$s = e^{-nt} (C_1 \sin (p^2 - n^2)t + C_2 \cos (p^2 - n^2)t) - \frac{q}{(p^2 - \omega^2)^2 + 4\omega^2n^2} \cos \omega t + \frac{q(p^2 - \omega^2)}{(p^2 - \omega^2)^2 + 4\omega^2n^2} \sin \omega t$$

s, in the above expressions, is the displacement in the direction S. The expression for the forced vibration of the system may be written as,

$$S_t = C_0 \sin (\omega t - \alpha) \dots\dots\dots (2)$$

Where,

$$C_0 = \frac{q}{\sqrt{(p^2 - \omega^2)^2 + 4\omega^2n^2}} \dots\dots\dots (3)$$

$$\alpha = \tan^{-1} \frac{2\omega n}{p^2 - \omega^2}$$

Since (1) is an ordinary linear equation with constant coefficients it follows that $2\pi/\sqrt{p^2 - n^2}$ is the natural period of the system (when the applied forces are zero). In vibrating systems of the type with which we are concerned $p \gg n$. We may, therefore, neglect n^2 in comparison with p^2 and take the natural frequency of the system to be $p/2\pi$. Resonance occurs when the frequency of the applied force equals the natural frequency of the system; i. e., when $p = \omega$, or $\sqrt{gb/W} = 2\pi f_1$. That is,

$$f_1 = \frac{1}{2\pi} \sqrt{\frac{g}{\Delta s}} \dots\dots\dots (4)$$

Where, $\Delta s = W/b =$ the static deflec-

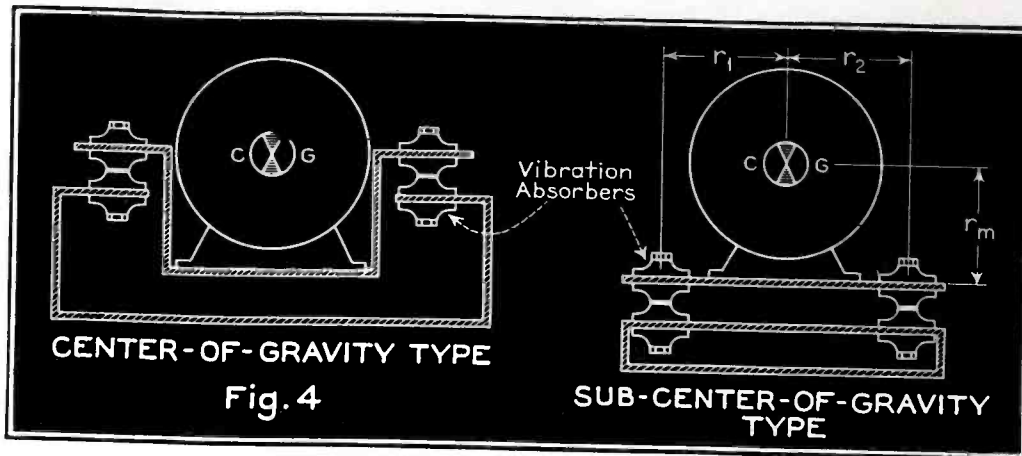

tion of the system under the weight W. It follows then that, in a system in which the frictional forces are small, the resonant frequency depends entirely upon the compliance of the system in the direction of the vibratory motion and, therefore, on the static deflection of the system under the weight W.

For satisfactory insulation, it is necessary to choose an elastic structure having a stiffness b such that resonance occurs below the lowest frequency at which it is desired to insulate the system. This follows from a consideration of (3). At resonance $p^2 - \omega^2 = 0$ and, since n is small, it follows that C_0 becomes very large. The magnitude of motion of the equipment we desire to insulate becomes much greater than the amplitude of the vibration we are attempting to insulate against. Excessive mechanical stresses are set up in the structure which are likely to cause subsequent breakdown. Clearly when the amplitude of the resulting motion is increased rather than decreased, our vibration absorber has become instead a vibration amplifier and, in most instances, the equipment would be less likely to be damaged if we provided a rigid mounting.

We may also write,

$$C_0 = \frac{\Delta_{st}}{\sqrt{(1 - f_1^2/f^2)^2 + f_1^2G^2/f^2}}$$

Where, $f = p/2\pi$, $f_1 = \omega/2\pi$, $G = 2n/p$, $\Delta_{st} = F_0/b$.

Since Δ_{st} is the deflection of the system under the applied force F_0 , it follows that,

$$B = \frac{1}{\sqrt{(1 - f_1^2/f^2)^2 + f_1^2G^2/f^2}}$$

is a measure of the effectiveness of our vibration absorber and is a quantity that we desire kept as small as possible.

Substituting for Δ_{st} , its value, we may write,

$$C_0 = B(F_0/b) = B(F_0/Kf_1^2) \dots\dots (5)$$

Where $K = (2\pi)^2W/g$.

(5) indicates that if the amplification factor, B, is maintained constant as the natural period of the system is increased, then the force, F_0 , driving the system at a frequency f_1 , at or near resonance, must increase as the square of the frequency for any constant amplitude C_0 . Thus, it follows that the lower we can make the resonant period of the system the less likely the structure will be to fail if some unforeseen resonant condition should occur. This is an important consideration since relatively high frequencies of vibration (from 30 c-p-s up) occur during a level flight² and if we should design an insulating mounting to resonate just below this band we would probably encounter damaging vibratory conditions during preliminary engine warm ups, take offs, and landing when vibrations of appreciable duration and amplitude having frequencies as low as 6 c-p-s may occur.² A mounting designed to resonate at 10 c-p-s would, therefore, provide much better all-round protection for the equipment than one designed to resonate at 20 c-p-s, though both would be equally satisfactory during a level flight.

The quantity $f_1^2 G^2/f^2$, in the expression for B, depends on the damping constant n and may, for most practical mountings, be neglected except for frequencies at or near resonance where $p^2 - \omega^2$ becomes very small. Neglect-

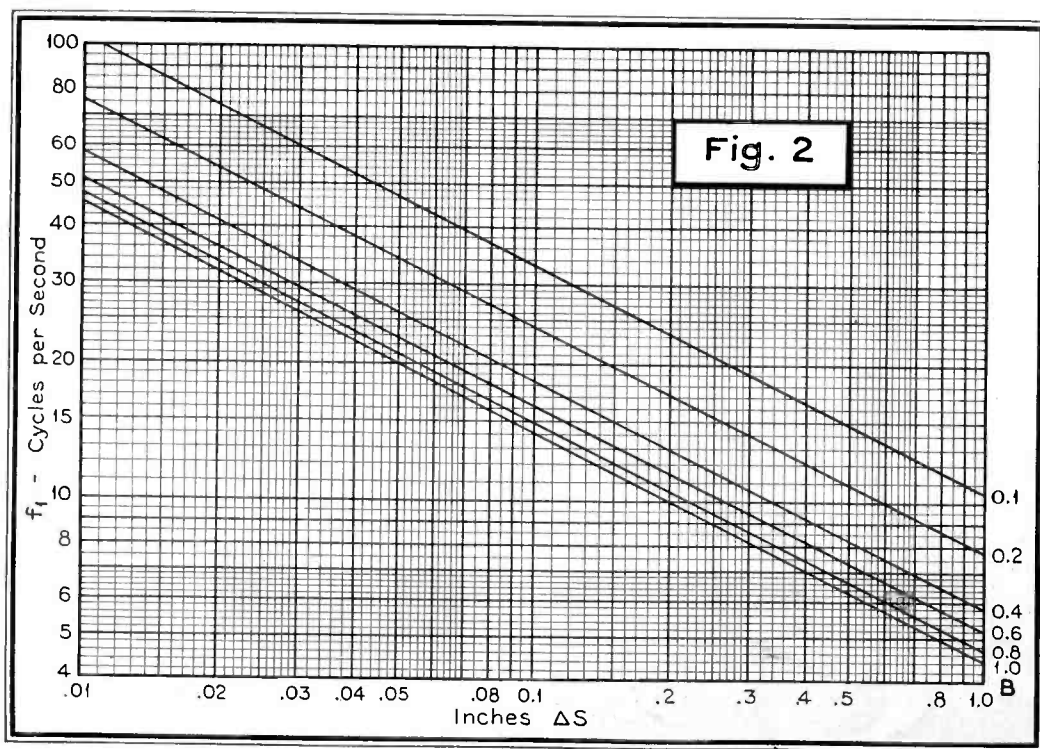

ing this quantity, we may write,

$$B = \pm \frac{1}{1 - (f_1/f)^2}$$

Taking the negative value of B, substituting for f its value, and rearranging we have,

$$\Delta s \cdot f_1^2 = (g/4\pi^2) (1/B + 1) = \text{Const.} \dots\dots\dots (6)$$

(6) will be recognized as a family of equilateral hyperbolas, each value we assign to B determining a particular hyperbola. Only the negative value of B will be considered; the positive value being imaginary for values of B less than one.

(6) is useful for predicting the performance of a given vibration absorber at various frequencies. Knowing the static deflection of the mounting, Δs , we may determine how much the absorber will reduce the amplitude of a vibration of frequency f_1 .

If (6) is plotted logarithmically the hyperbolas become straight lines and are somewhat easier to read and draw. A family of such curves is shown in Fig. 2. The value of B corresponding to each line is indicated. For example, if we desire a mounting that causes no change (unit amplification) in the amplitude of a vibration of 10 c-p-s, we must provide a static deflection, Δs , of 0.196 inches. Checking Fig. 2 still further we see that this mounting will reduce the amplitude of a vibration having a frequency of 23.5 c-p-s to 0.1 of its original amplitude.

III—Rotational Vibration

In the discussion of the mechanical system of Fig. 1 it was assumed that the turning moment of the mass about an axis in its mounting plane was negligible. This is not necessarily true, and when the turning moment is relatively large it is necessary to consider its effect on the foregoing analysis.

This will be clear from a consideration of Fig. 3. Here the mass is located so that its center of gravity is above the plane of the mounting a distance r_m . The mounting structure is

supported, by means of isotropic compliances, at points distances r_1 and r_2 respectively from the point at which the mass ($M = W/g$) is attached. A force $I_o(t)$, causing a vibratory motion of the mounting structure in the horizontal direction, will cause rotation about the center of gravity of the system. Such a force will be opposed by:

(1) The force due to the accelerated mass =

$$(W/g) (r_m^2 + i^2) d^2\theta/dt^2.$$

$(W/g) (r_m^2 + i^2)$ is the moment of inertia of the mass about an axis in the mounting plane and i is the radius of gyration of the mass about its center of gravity.

(2) The force due to friction or viscous damping =

$$C_{r1}r_1^2 + C_{r2}r_2^2 d\theta/dt.$$

Where C_{r1} and C_{r2} are the damping constants at the two points of suspension.

(3) The force due to the stiffness of the elastic elements in the direction of rotation = $(b_{r1}r_1^2 + b_{r2}r_2^2)\theta$. Hooke's law assumed. b_{r1} and b_{r2} are the stiffnesses of the two elastic elements at the points of suspension.

Adding the counter forces 1, 2, and 3,

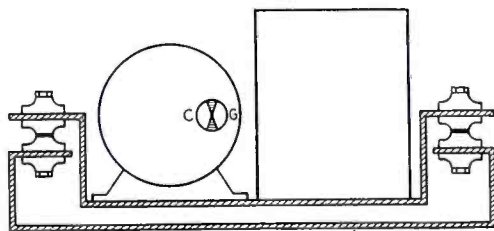

Fig. 5

and equating them to the applied force, we have,

$$(W/g) (r_m^2 + i^2) d^2\theta/dt^2 + (C_{r1}r_1^2 + C_{r2}r_2^2) d\theta/dt + (b_{r1}r_1^2 + b_{r2}r_2^2)\theta = I_o(t).$$

If C_{r1} , C_{r2} , b_{r1} , and b_{r2} are constants, a condition compatible with most practical conditions where the angle of movement is comparatively small, the above is a linear equation with constant coefficients and may be compared directly with (1) which was derived for a translatory motion. Dividing through

by $(W/g) (r_m^2 + i^2)$ we obtain,

$$d^2\theta/dt^2 + (2n_r) d\theta/dt + p_r^2\theta = q_r(t) \dots\dots\dots (7)$$

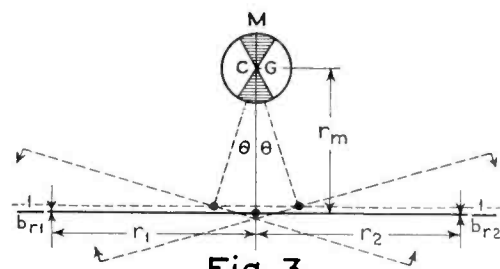

Fig. 3

$$n_r = \frac{g(C_{r1}r_1^2 + C_{r2}r_2^2)}{2W(r_m^2 + i^2)},$$

$$p_r^2 = \frac{g(b_{r1}r_1^2 + b_{r2}r_2^2)}{W(r_m^2 + i^2)},$$

$$q_r = \frac{gI_o}{W(r_m^2 + i^2)}$$

Assuming $n_r^2 \ll p_r^2$ we see that the resonant period of the rotary mode of vibration is given by $2\pi/p_r$ and $2\pi f_r =$

$$p_r = \sqrt{\frac{g}{W} \sqrt{\frac{b_{r1}r_1^2 + b_{r2}r_2^2}{(r_m^2 + i^2)}}}$$

For translatory motion, as described by (1), $p = \sqrt{gb/W}$, where b is the total stiffness of the system. If we have a two-point symmetrical suspension, such as is now being considered, we may write $b = 2b_t$; b_t being the stiffness at each point of suspension. Therefore, $p = \sqrt{2gb_t/W} = 2\pi f_t$ and,

$$\frac{f_r}{f_t} = \sqrt{\frac{b_{r1}r_1^2 + b_{r2}r_2^2}{2b_t(r_m^2 + i^2)}}$$

If $b_{r1} = b_{r2} = b_t$, then, for a level suspension, $r_1 = r_2 = r_o$ and we may write,

$$\frac{f_r}{f_t} = \sqrt{\frac{r_o^2}{r_m^2 + i^2}} \dots\dots\dots (8)$$

That is, under these conditions, if $r_o^2 = r_m^2 + i^2$, the natural period of the rotational mode is equal to the natural period of the translatory mode. This is a very desirable condition since, when the natural periods of both modes are the same, unexpected vibratory modes are much less likely to be encountered. This indicates the importance of using vibration-absorber units exhibiting equal stiffness in all directions, and of locating them symmetrically with respect to the center of gravity of the supported mass. Vibration absorbers having unequal stiffnesses in various directions will have as many different periods of vibration at as many different modes. The performance of such a unit is difficult, if not impossible, to predict and is likely to be unsatisfactory.

(Continued on page 24)

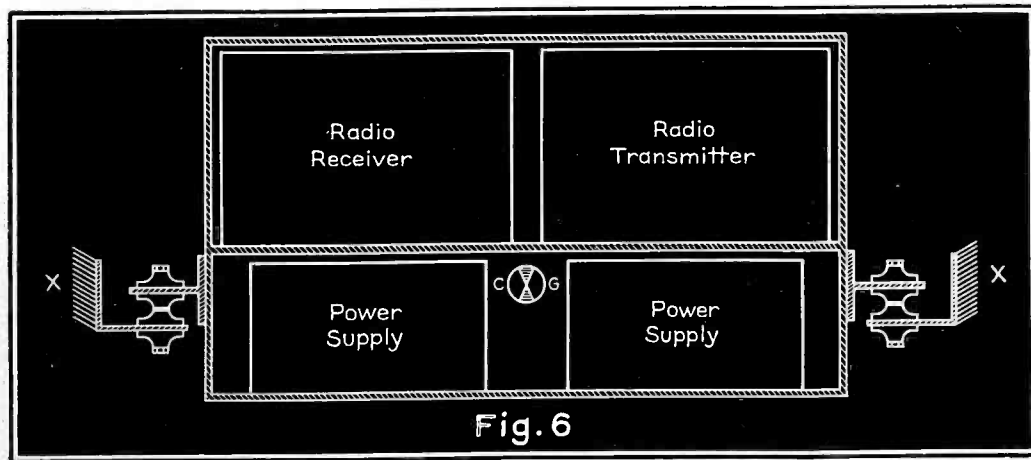

Fig. 6

VOLTAGE DIVIDERS

for extended frequency ranges

NOW that the communication industry is thinking in terms of megacycles instead of kilocycles as far as carrier frequencies are concerned and since the "audio" range in television has stretched to a band many millions of cycles in width, it seems necessary that we reconsider the fundamental action of the voltage divider in order to make it behave properly under the abnormal conditions to which it is so often subjected.

In dealing with resistance dividers at audio frequencies, the tacit assumption is often made that the action of the resistance divider is independent of frequency. Although the lower frequencies only are often under consideration, the student or experimenter may extend this reasoning to the higher frequencies, a procedure that may be wholly in error and one that may lead to disastrous results. In working with television signals, square-waves, wide-band amplifiers, or transients having high-frequency components, this casual attitude will spell defeat by frequency discrimination.

The voltage division ratio of any resistance divider will deviate from its d-c ratio at some frequency at which the impedance of the resistance elements deviates from essentially a pure resistance. Every resistor has a certain amount of inductance and capacitance which may be neglected at ordinary frequencies. At high frequencies the distributed capacitance may dominate the situation because of its shunting effect. In general, it may be said that the resistance voltage divider falls down at the high fre-

Resistance voltage divider with capacitance divider in parallel.

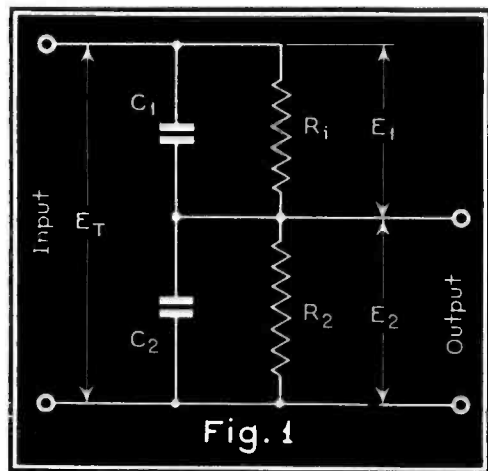

Fig. 1

By F. ALTON EVEREST

Department of Electrical Engineering
Oregon State College

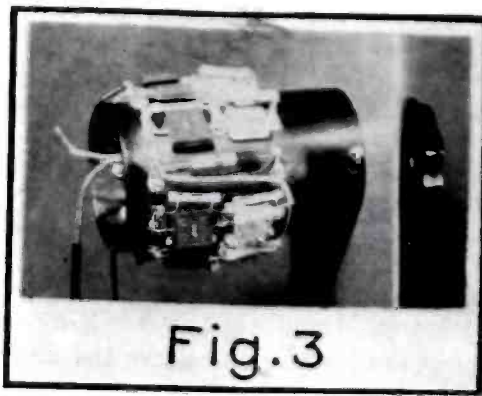

Fig. 3

A laboratory type of balanced attenuator.

quencies because of this shunting effect. The inductive effects of most commercial resistors can, for frequencies not too high, be neglected.

Resistance Divider Analysis

Let us analyze the "inverted L" type of attenuator or voltage divider shown in Fig. 1. We will include the capacitive shunting elements to make the analysis general. The impedance of R_1 and C_1 in parallel is

$$Z_1 = \frac{(R_1) \left(-j \frac{1}{\omega C_1} \right)}{R_1 - j \frac{1}{\omega C_1}}$$

which may be simplified by multiplying the numerator and denominator by $-j\omega C_1$

$$Z_1 = \frac{R_1}{1 + j\omega C_1 R_1} \dots \dots \dots (1)$$

In a similar manner the impedance of R_2 and C_2 in parallel is given by

$$Z_2 = \frac{R_2}{1 + j\omega C_2 R_2} \dots \dots \dots (2)$$

The total impedance is

$$Z_T = Z_1 + Z_2 = \frac{R_1}{1 + j\omega C_1 R_1} + \frac{R_2}{1 + j\omega C_2 R_2} \dots \dots (3)$$

The voltage dividing ratio $\frac{E_2}{E_T}$ is given by

$$\frac{E_2}{E_T} = \frac{Z_2}{Z_1 + Z_2} = \frac{R_2}{Z_T} \dots \dots \dots (4)$$

By substituting (1) and (2) in (4) we get

$$\frac{E_2}{E_T} = \frac{\frac{R_2}{1 + j\omega C_2 R_2}}{\frac{R_1}{1 + j\omega C_1 R_1} + \frac{R_2}{1 + j\omega C_2 R_2}}$$

which may be simplified to

$$\frac{E_2}{E_T} = \frac{R_2 (1 + j\omega C_1 R_1)}{R_1 (1 + j\omega C_2 R_2) + R_2 (1 + j\omega C_1 R_1)} \dots \dots (5)$$

A careful inspection of equation (5) will disclose the fact that the $\frac{R_2}{R_1 + R_2}$

factor (which describes the voltage dividing ratio at d-c or low frequencies at which R_1 and R_2 act as pure resistances) is included. However, each term is altered by a factor dependent upon frequency. If the frequency is made zero (d-c), the terms of equation (5) within the parentheses reduce to unity and

$$\frac{E_2}{E_T} = \frac{R_2}{R_1 + R_2}$$

results.

Another judicious inspection of equation (5) reveals the very important fact that if $C_1 R_1 = C_2 R_2$ the imaginary part of each term becomes the same. In other words if $C_1 R_1 = C_2 R_2$ the voltage

division ratio $\frac{E_2}{E_T}$ will be independent of

frequency. If then we can adjust the time constant of Z_1 to be equal to that of Z_2 , the attenuation will be independent of frequency.

Fig. 2 shows the calculated effect of capacitive unbalance on a typical voltage divider composed of two resistances of 0.8 and 0.2 megohms. The resistor R_2 is assumed to be connected to a device such as a vacuum tube grid circuit

having an input capacitance C_2 of 20 mmfd. The magnitude of the capacitance C_1 determines the frequency response of the divider. If C_1 were zero, the drooping response shown in Fig. 2 is obtained. A value of C_1 of 10 mmfd gives a rising characteristic. The possibility of using this principle in high-frequency compensation of wide-band amplifiers immediately suggests itself. If C_1 is 5 mmfd the time constants of both sections of the divider network are the same and theoretically the voltage-division ratio is uniform at all frequencies.

If the ratio $\frac{C_1 R_1}{C_2 R_2}$ is greater

than unity, a rising characteristic results, and if less than unity, a drooping characteristic results.

The capacitances involved are under certain conditions of more or less indefinite magnitude, such as, for instance, various distributed capacitances. Two paths of action are suggested: Use the distributed capacitance for one of the elements in the capacitive divider, or render it negligible by inserting a larger capacitance, i.e., literally "swamping" it. The use of stray capacitance for one of the circuit elements has a great disadvantage in that it changes with the proximity of surrounding objects. For instance, closing a door on the metal cabinet might upset the balanced conditions. Placing capacitors across the resistance divider of a size sufficient to render stray capacitance changes ineffective is to be preferred. The size of these capacitors is limited, however, by the capacitive loading placed upon the source. The input impedance of the device into which the voltage divider is working should be large compared to the voltage divider or a further error will be introduced. In other words, an attenuator for wide-band operation should be especially designed for use in its particular circuit.

Application of Wide Band Attenuators

The photograph of Fig. 3 shows a step-by-step attenuator which was constructed for use in the input circuit of a video amplifier. The frequency characteristic of the attenuator is essentially flat out to 2 megacycles. The bakelite tube serves as a convenient mounting for the resistance and capacitance elements, providing short leads to the selector switch placed within the tube. Note the use of ceramic-mounted trimmer condensers for the adjustable element.

The circuit of Fig. 4 illustrates a method of switching for an attenuator for wide band use. The rather unusual isometric sketch is used to illustrate as simply as possible the connections to a three-circuit selector switch. A schematic diagram for each of the five steps

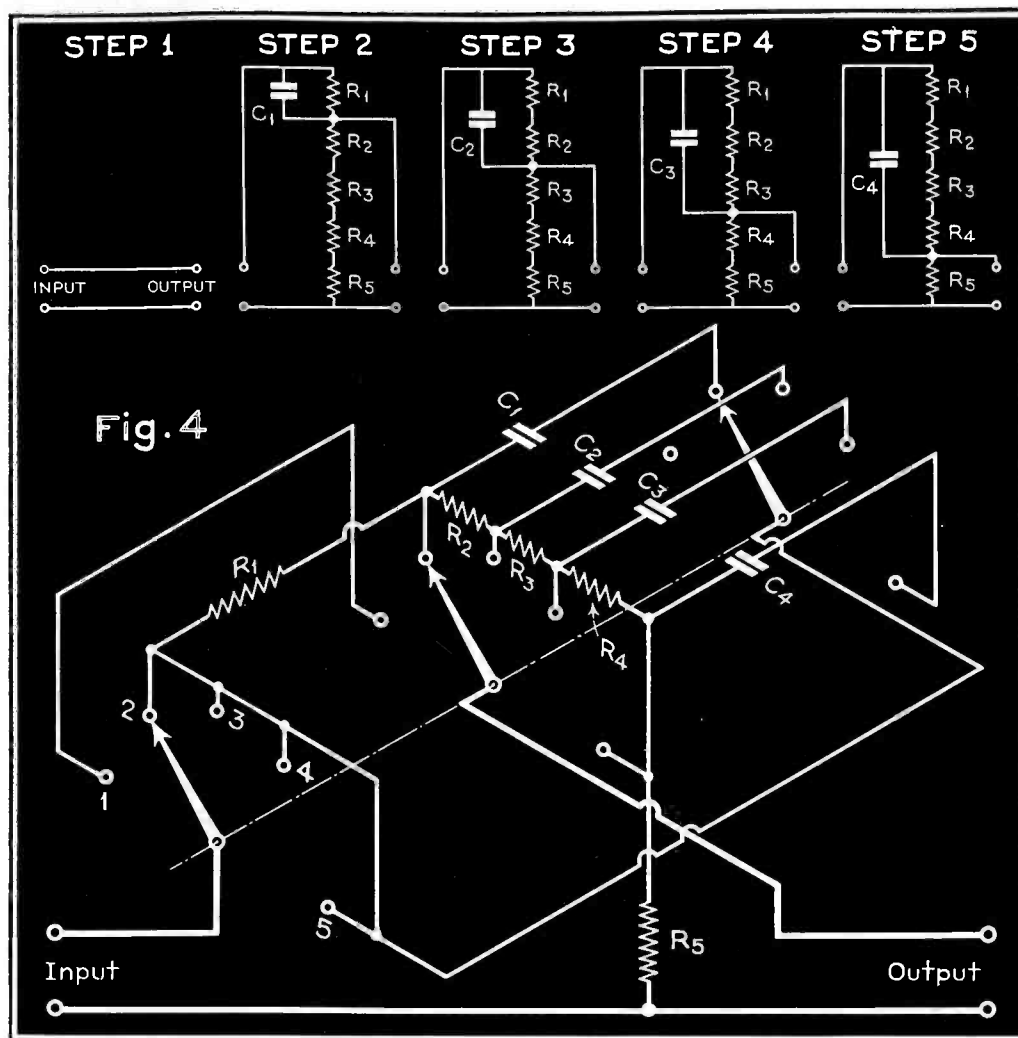

Circuit of attenuator arrangement.
 C_1 to C_4 normally adjustable.

is also shown above. This attenuator is obviously designed to work into a certain capacitance which, with capacitors C_1 to C_4 , completes the capacitive divider in shunt with the resistive divider. The capacitors C_1 to C_4 would normally be made adjustable.

An attenuator such as shown in Fig. 4 operates in steps the magnitude of which is fixed by design. For many

Frequency response. Voltage division independent of frequency when $C_1 R_1 = C_2 R_2$.

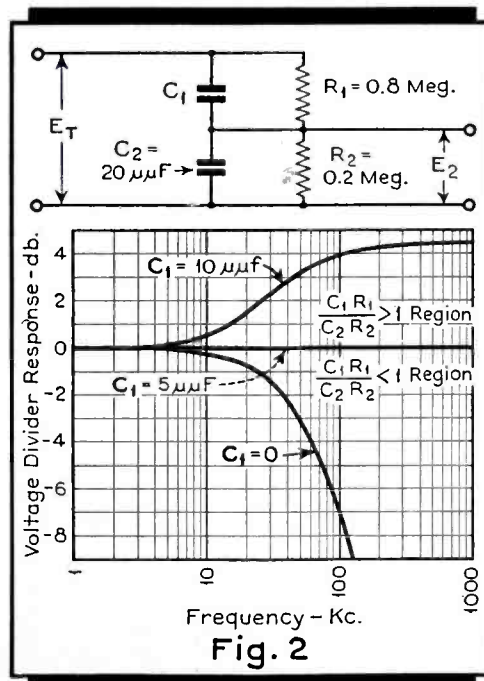

Fig. 2

services, much finer adjustments are necessary. Another fine attenuator in series with a coarse one is normally not a satisfactory approach to the problem because the setting of one influences the other. A commonly accepted method is to devise a step-by-step attenuator for approximately 10% steps and to control the gain of the amplifier (if such is the use) by other means within the 10% steps, such as the variation of screen voltage within narrow limits.

Adjustment of Attenuators

One of the simplest methods of adjustment of balanced RC attenuators designed for wide band use is by means of square-wave response.² A square wave is applied to the input of the attenuator and the output wave shape is studied by a special cathode-ray oscilloscope. A greatly distorted wave results for any but the correct setting of the adjustable capacitor. This allows a rapid visual adjustment suited for production adjustment and testing. The disadvantage of this system lies in the expensive equipment necessary.

Satisfactory adjustments may be obtained by measuring the attenuation ratio at a relatively low frequency and at some high frequency, say several megacycles, or at least at the upper edge of the band to be used, the adjustable capacitor is adjusted until the same attenuation ratio is obtained at

(Continued on page 22)

Satellite Studio

MANY broadcast stations have found it desirable to install equipment for use in satellite studios. These studios may be located from five miles to fifty or one hundred miles from the main studio to allow broadcasts from an adjacent town. Since a studio of this type may be used only a part of the broadcast day, perhaps ten per cent of the time, it becomes an economic problem. The cost must be kept low, yet the operation of the equipment must be extremely reliable and flexible. A maintenance engineer will ordinarily not be available at the remote studio, therefore reliability and conservativeness of design must be observed. Centralized control and compactness are factors contributing to reliability. This article describes equipment suitable for meeting the above requirements.

A common office desk was used for mounting the speech-input equipment instead of the characteristic relay rack. The arrangement of the equipment is shown in Fig. 1. It should be noted that the desk selected for this use required only an inexpensive mechanical alteration. The right hand part which normally housed drawers was widened to accommodate a section of a standard 19-inch relay rack. The amplifiers were constructed on inverted chassis bases equipped with wing flanges to allow their mounting on the rack. Over the front of these units, standard relay rack panels or mats were used. Removal of these mats exposes all wiring and connections.

The desk was further modified to allow both ends to be equipped with removable panels so that ready accessibility was insured for wiring, maintenance, and testing. The opposite side of the desk was equipped in a similar manner except that 13½" panels were used because widening this section to 19" did not leave adequate knee space. A channel installed in the top of the desk made it possible for interconnecting wires to be placed between the units mounted in the racks on either side of the desk. Over the top of this channel, as can be seen from Fig. 1, is placed a console which holds all of the voice circuit switches, faders, gain controls and the volume indicator. The mechanical layout was arranged to make wiring simple and to isolate the power-supply units. The power supplies, receiver, and oscillator are all in one end, and the amplifiers are in the other end of the

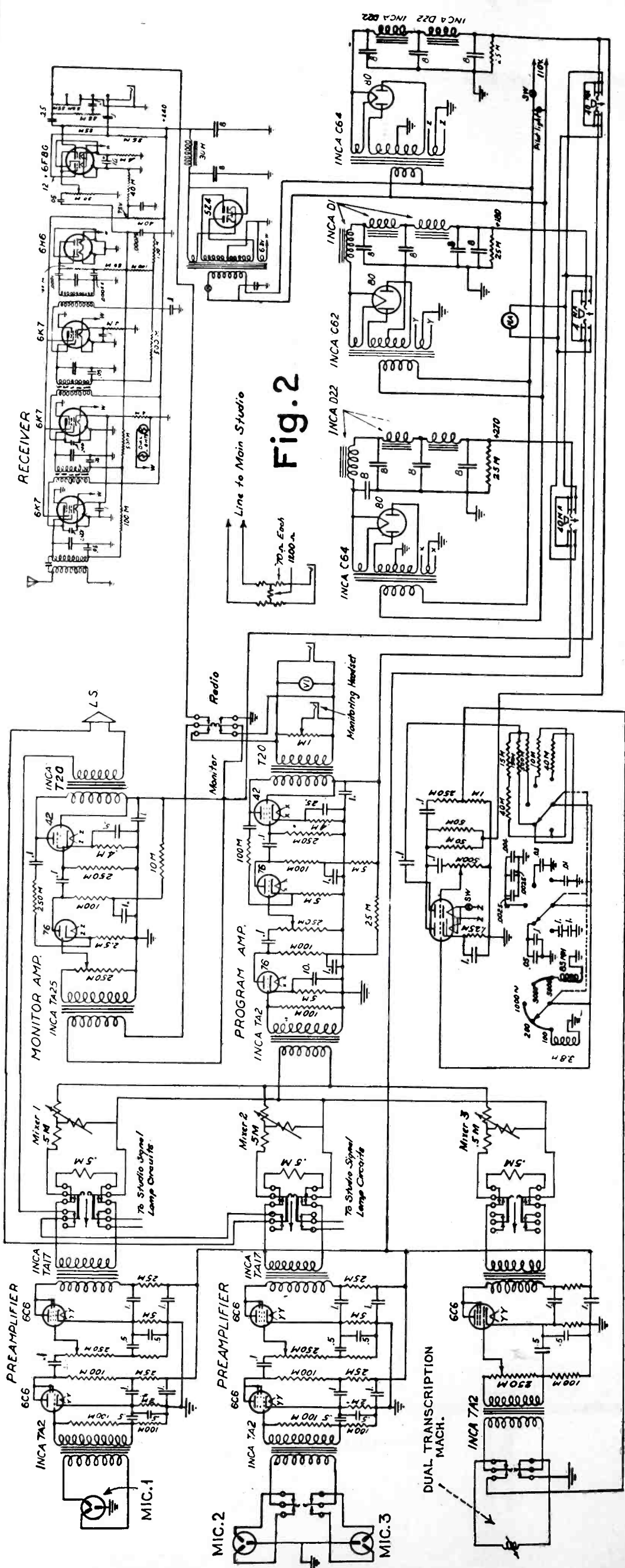

Fig. 2

Equipment

By **GRANT S. FEIKERT**

Chief Engineer
KOAC

desk. This mechanical isolation added materially to freedom from hum.

The electrical requirements dictate that a system of this type be capable of accommodating at least three microphones. Microphone connectors are mounted in the end of the desk, allowing short leads to the pre-amplifiers. In addition to the three microphone circuits, facilities have been included for handling a dual transcription table. In the installation described dual speed motors were used in order to maintain economy compatible with design, since the studio was operated only part time.

As shown in Fig. 2, the pre-amplifiers use type 6C6 tubes connected as triodes and have an overall gain of approximately 50 decibels. Complete decoupling of both grid and plate circuits has been included, and each pre-amplifier is equipped with a voltage divider between tubes. This facilitates adjustment of the output of each channel. Pre-amplifiers of this design, using the components indicated in Fig. 2, have been found to be extremely stable and of excellent frequency response. The use of 6C6 tubes has not given trouble from microphonic noise.

The two pre-amplifiers and the transcription channel operate through one position, locking type key switches into a three-channel parallel type mixer. The output of this mixing system operates directly into the program amplifier which consists of two triodes operating into a type 42 tube connected as a triode.

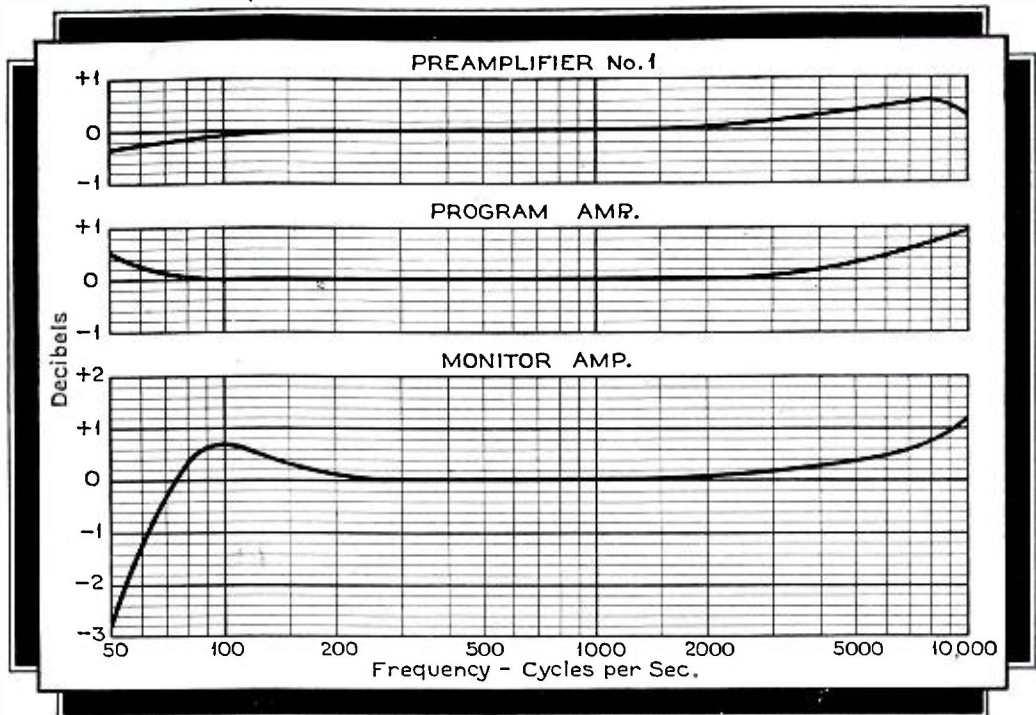

Fig. 3. Frequency characteristics of preamplifier, program and monitor amplifiers.

Negative feedback was used on this amplifier with the result that its frequency response was improved and the noise level lowered. The output of this unit is fed into a jack which connects, by means of a patch cord, to the line to the main studio. The output connection of this amplifier was also extended to one side of a two-position, locking-type key and connected in turn to the input of the monitoring amplifier. On the opposite position of this monitoring key the radio tuner makes available the program from the transmitter.

The radio receiver may be tuned to the transmitter of the master station which is being fed through the monitoring amplifier. This procedure insures perfect cueing of the remote studio program. Practice has shown that an hour

Fig. 1. Showing arrangement of the studio equipment

program can be very smoothly run from this satellite studio with the announcer stationed fifty miles away in the main studio of the system.

The key switches operating on the output of the pre-amplifier and the transcription channel are equipped with contacts to break the studio loudspeaker circuits, during the time that any of the microphones are connected to the line.

On the console front the three switches to the left of the volume indicator, when viewed from the operator's position, are the two microphone and the transcription switches respectively. On the right appear the microphone selector key on Channel 2 as shown in the circuit of Fig. 2, the key selecting either the transcription circuits or the output of the audio oscillator used for line equalization, and the monitor key which places the monitoring amplifier and studio speakers on either the radio receiver or the output of the local studio system.

Probably the outstanding feature of this installation is the oscillator used for equalizing the transmission line. This oscillator, which uses a 6A6 tube, is of the controlled feedback type. A three-gang switch is used, as shown in the wiring diagram of Fig. 2, for the selection of any one of five audio frequencies which are indicated in the diagram. The resonant values of circuit constants to produce the desired frequencies are shown. The third arm of the multiple switch is used to select one of several resistors which maintain a constant voltage output from the oscillator for any pre-determined frequency.

It is a matter of routine procedure to make a frequency run on the line in as short a time as three seconds, or as fast as the operator at the main studio can read the volume indicator. This feature

(Continued on page 23)

MARINE TELEPHONE FOR SMALL BOATS

By S. GORDON TAYLOR

HAD someone made the statement twenty years ago that there would be telephones on pleasure and small commercial boats, capable of rendering exactly the same service as the instrument on the office desk or library table, it is possible that his statements would have been labeled another Jules Verne fantasy. Had he gone further, and stated that this would be possible without the use of complex equipment on board under the paid ministrations of a professional operator, then a listener familiar with the strict rules and regulations of the government radio authorities would have probably expressed a more cogent and perhaps less polite opinion of both the story and the narrator.

Today the owner of a pleasure boat cruising down the coast can pick up a telephone hand-set and call any land phone with exactly the same ease that he could were he sitting at his office desk. Or the dispatcher of a fleet of tugs can contact the captains of any of the boats at any time, without waiting for the boat to put into shore to phone for orders. In the same way, fishing boats can phone in from sea for market quotations, or to arrange for the sale of the catch almost before it is out of the water.

Some three or four years ago there was a burst of publicity on the then experimental "Harbor Radio." Since that time little has been heard about it although in the meantime it has become an established enterprise. At the present time there are four regularly established marine exchange stations distributed along the east coast, with a fifth proposed to complete the service area coverage of the entire coast from Maine to Florida. There are similar stations now operating at Los Angeles, San Francisco and Seattle, providing coverage of a greater part of the coastal

Top view of 30-inch model shown above.

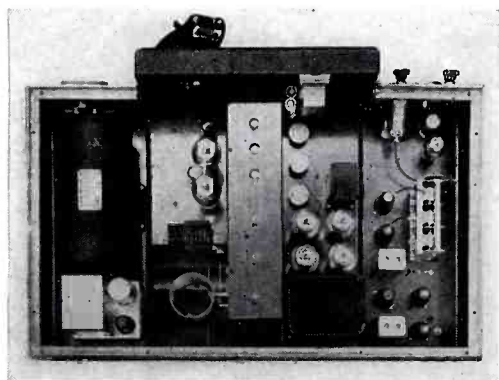

waters of the Pacific; and stations are proposed for New Orleans and Galveston, to extend the east coast service area around into the Gulf. Such is the contribution of the Bell Telephone System to this service.

That the service has proven beneficial to boat owners is definitely indicated by its growing popularity. Records of the New York City marine telephone exchange, for instance, show that the number of calls handled through this station during the past few months represents an increase of more than four hundred per cent over the corresponding months of last year.

In addition to communication with land-wire phones through the connecting link of the marine exchange, he is able to talk direct with other similarly equipped boats within range of his equipment, and for this purpose the frequency of 2738 kilocycles is set aside by the FCC. Further, in case of emergency, he is privileged to call the nearest coast guard station either direct on the 2670-kc Coast Guard stand-by channel, or via the marine exchange ashore. Thus the marine telephone provides

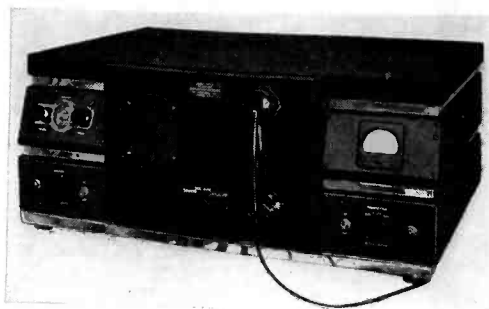

Above: This 30-inch table mounting unit houses receiver, transmitter, power supply.

Below: Another model providing five transmitting and receiving channels plus weather receiving bands.

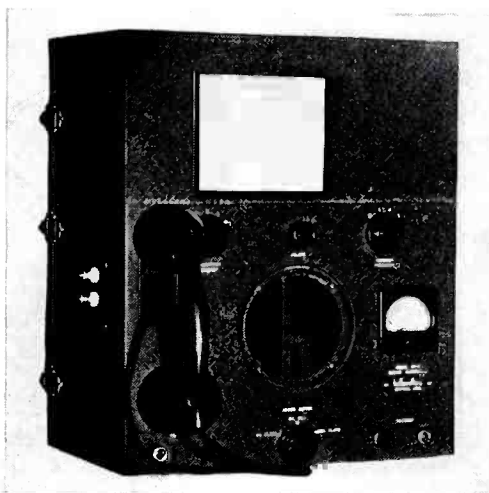

safety and convenience in addition to practical utility.

Calls placed through the telephone company's shore stations are charged for at regular toll rates, as from that shore station's location, plus a flat handling charge to cover the marine-radio link. Direct ship-to-ship calls involve no charge but if the two boats are so separated as to make direct contact impossible, they can communicate through the shore system paying the usual charge for the land wire link.

As for the equipment used on board the boat, it must be of special design as well as simple and foolproof in operation so that it can be used regularly by the owner or captain who may have no technical knowledge whatsoever. This is one service in which the FCC has let down the bars to the extent that the apparatus need not be operated by, nor even under the supervision of, the usual professional operator. The only requirement is a third class operator's license, to obtain which involves mainly a knowledge of radio rules and regulations rather than the technical end.

The power required depends on two things—the required service area and the power source available. Some installations use as little as 10 watts and find it ample where only "local" contacts are required. A 25 to 50-watt carrier is generally preferred, however, as it provides more dependable coverage for longer hops and a reserve for closer contacts under adverse conditions.

To make such low power more effective, the marine exchanges have listening stations spotted at strategic points within the service area of the mother station, these posts relaying the boat's signal over the land line to the exchange. Thus the New York exchange has four pick-up stations in the Bay and Long Island Sound, one of them some

(Continued on page 28)

Bottom view of unit shown at top of page.

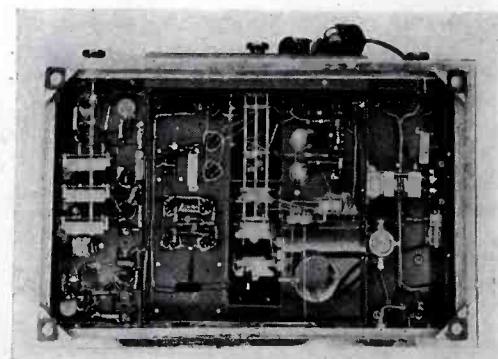

TELEVISION ENGINEERING

ANTENNAS AND TRANSMISSION LINES at the EMPIRE STATE TELEVISION STATION

By **N. E. LINDENBLAD**
RCA Communications, Inc.

INTRODUCTION

SPEED and detail of picture scanning in television can result in corresponding definition only to the extent that the circuit media can be made non-distorting over corresponding frequency bands. In order to make such circuit performance at all possible, it has been found necessary to employ carrier frequencies in the so-called ultra-high-frequency region.

It has, however, been considered advisable to use carrier frequencies no higher than necessary to provide, what at present appears to be, a fair compromise between diverging causes of limitation, although high enough to provide, within a geographic territory, a reasonable number of channels of similar propagation characteristics. The wide-band requirements in high-definition television have called for careful consideration of details and have also lead to the application of unconventional designs in radio-frequency circuits and antennas. This became especially true when it was attempted to bring out the full definition possible at such detail picture scanning as 441 lines.

Introduction of horizontal polarization for television transmission added complications to the design of antennas of the broadcasting type.

Long lines must frequently be used between transmitter and antenna. Under such conditions the antenna characteristics must closely match the characteristic impedance of the line

The first of three articles on this unique development in antennas and transmission lines.—Editor.

throughout the operating frequency band. Also, the transient state of all vision circuits must be of short duration and cause a minimum of reflection.

Coupling between sound and vision transmitters must be kept low although sound and vision modulated carriers of smallest possible frequency separation must be radiated from the same radiating structure or from adjacently located separate structures.

In order that the reader may gain a

Showing point at which optimum power transfer occurs.

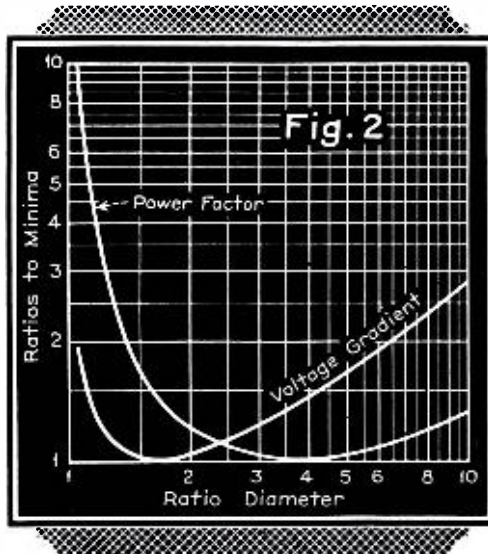

full perspective of the development of radiation structures for the Empire State Building television transmitting station, the general circumstances forming the background to the particular design conditions to be met will be reviewed.

Since correct application of transmission-line principles is vital to success in providing a radiating system for television, these principles will be discussed in some detail.

Various antenna types used at the Empire State Building will be described.

The principles of a new wide-band antenna for vision transmission will be discussed in detail and illustrated by experimental data. The application of these principles to experimental models and to the new antenna recently erected on top of the Empire State Building will be demonstrated. The electrical as well as the mechanical design features of this antenna will be described.

It will be shown how the vision portion of this new antenna has a constant resistive input characteristic over such a wide range of frequencies that even possible future band expansions and shifts in carrier frequency may be amply accommodated.

SELECTION OF CARRIER FREQUENCY

The selection of proper spectral location for television carrier frequencies presents the problem of compromising within certain borders of practical possibilities and will probably be subject to revision as the art progresses.

Within the borders of practical possibilities there are many factors to be considered.

The virtues of the lower carrier frequencies are: ease of producing high energy levels, slower drop in signal strength with distance beyond line of sight and less shadow effects.

The handicaps at the lower carrier frequencies are: greater percentage band width, sporadic long distance effects, higher noise levels and larger radiator dimensions. The band-width percentage is inversely proportional to the carrier frequency. At the high modulation frequencies, called for in high-definition television, it therefore becomes increasingly difficult to provide a sufficient number of channels at the lower carrier frequencies.

The carrier frequencies used at the Empire State Building television station have been in the 40 and 50-mc region.

POLARIZATION

In order to determine which type of polarization results in the most favorable propagation, a number of surveys were made. The most urgently needed information was regarding which type of polarization would result in minimum multipath phenomena and noise.

The propagation characteristics of vertical, horizontal and circular, or rotary, polarization were studied at various frequencies. It was found that horizontal polarization was not only superior to vertical polarization, but also to circular polarization.

Radiation having polarization which is parallel to a perfectly conductive surface will have its polarity reversed upon reflection against the surface. In the case of polarization which is per-

pendicular in respect to the conductive surface there is no phase reversal upon reflection. Circularly polarized radiation when striking a conductive surface at an angle will have both parallel and perpendicular components in respect to the surface. The direction of rotation is therefore reversed upon reflection.

By combining several antennas at various angles of polarization and connecting them at progressive phase in proportion to their relative angular displacement such a system becomes selective in respect to rotation of the plane of polarization. It was therefore hoped that by such an arrangement the intensity of all odd multiples of reflection would be greatly reduced.

Due to the fact, however, that buildings do not present perfect conductive surfaces and also because the characteristics of the horizontal component, including noise considerations, are superior to those of the vertical component, the combination became less desirable than horizontal polarization alone.

TRANSMISSION LINE PRINCIPLES

The magnetic and the electric energy of a traveling wave on a line are equal. The magnetic energy of a certain length of line equals the product of the current squared, the radian phase velocity and the inductance. The electric energy equals the product of voltage squared, radian phase velocity and capacity. The voltage-current ratio thus equals the square root of the inductance-capacity quotient regardless of radian phase velocity. This ratio is called the characteristic impedance of a line. When the terminating impedance of a line equals the characteristic impedance, the voltage-current ratio is not disturbed

in any way upon the arrival of a wave at the line termination. The energy of the wave is absorbed at the rate it arrives and there is no reflection at the point of termination.

Since current is directional and axial with the line conductor the phase when looking in the direction of the current is opposite to the phase when looking against its direction. The voltage on the other hand is, of course, of the same phase regardless of the direction in which it is observed. Looking in the direction of wave travel, voltage and current are in phase. Looking in the reverse direction, voltage and current are in phase opposition.

For a traveling wave, the difference of phase between two points on a line is directly proportional to the radian phase velocity and the distance. When disregarding phase shift due to line termination characteristics, the phase difference between voltages of direct and reflected waves at a point a certain distance from the end of the line is therefore directly proportional to the radian phase velocity and twice the distance between the point and the end of the line. The phase between the direct and the reflected wave thus varies with the distance between the point of reference and the end of the line.

Due to the reversal of phase between current and voltage upon reversal of direction of wave travel and due to the variation, with distance, in phase between components of the direct and the reflected waves, these entities will combine into the well known phenomenon of standing waves. At points where the voltages add numerically the currents will subtract numerically. In general, where the voltages of the direct and the reflected waves from a vector sum, the currents will form a vector difference and vice versa.

The resistance and the reactance of the termination will determine the relative phase between voltage and current at this point. At any other point the phase of the direct wave is later and the phase of the reflected wave is equally earlier than the phase at the reflection.

If the termination is only resistive and higher than the characteristic impedance of the line, the current surplus of the wave is reflected. Traveling in the opposite direction, the current of the reflected wave, at the source of reflection, is of opposite phase to the current of the direct wave. The voltage corresponding to the reflected current surplus is, of course, determined by this current and the characteristic impedance of the line over which the reflected wave is returning. In reference to the point of observation, it has already been stated that the voltage and current of a receding wave on a line in phase and

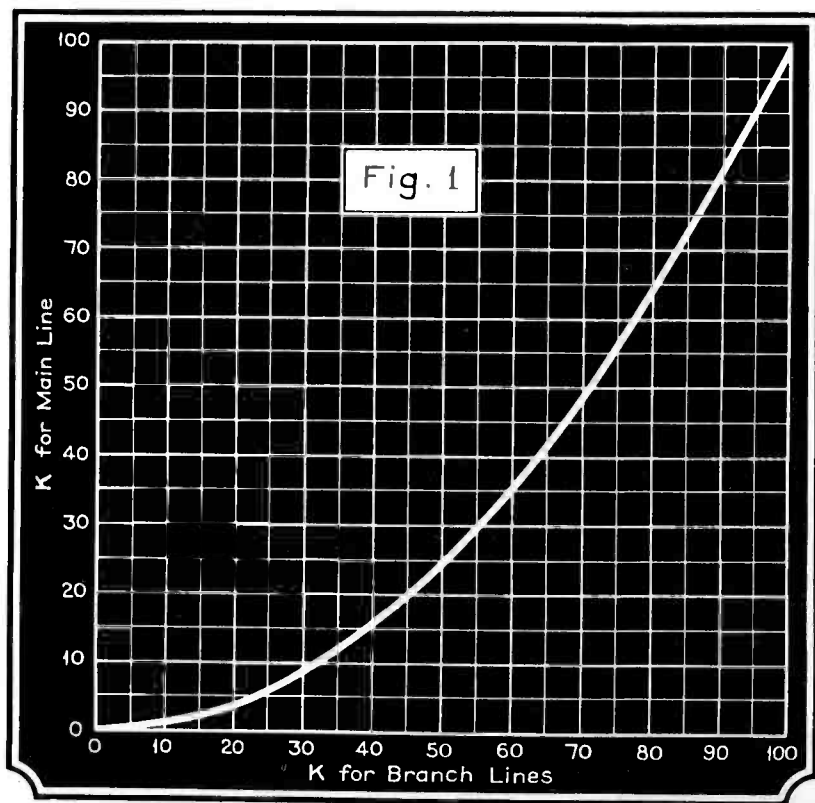

Showing that the reflection on the main transmission line becomes smaller than the reflection on the branches.

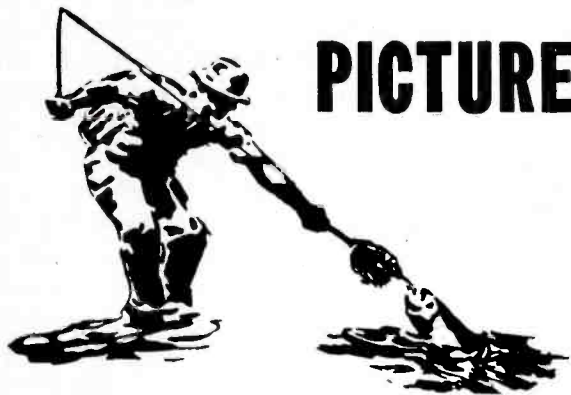

PICTURE OF ENGINEER WITH PROBLEM

and why it isn't insulation!

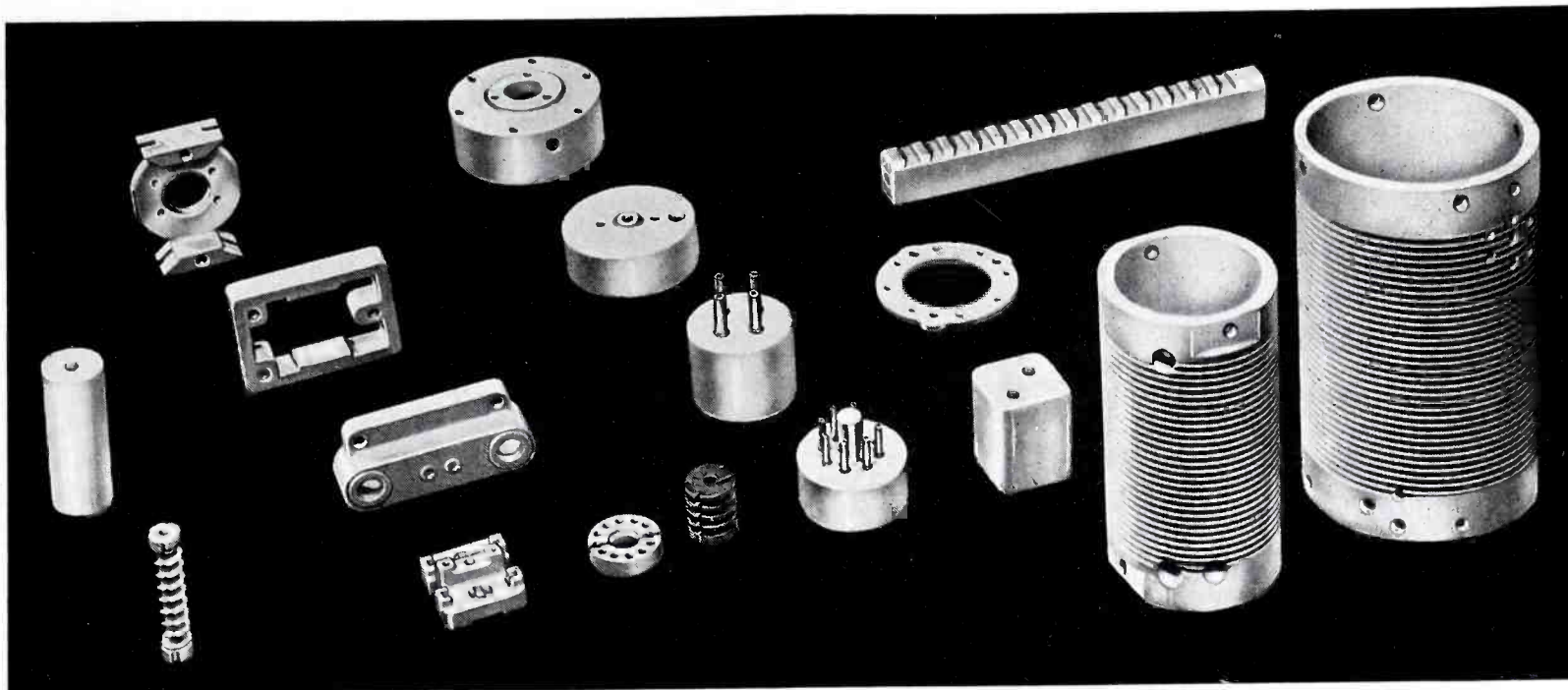

A frisky brown trout on the end of his line is all that's bothering this electronic engineer. He has solved his insulation problem—that's why he is on vacation.

If any one feature of the Alsimag Family of ceramic materials can be singled out for special mention, engineers agree it is the wide range of characteristics which can be obtained in order to meet every insulating requirement. And when you specify one of the Alsimag "bodies" even the Purchasing Department joins in the cheering, for Alsimag steatite ceramics generally cost no more! Our engineering and research staffs will be glad to help with your individual design problems.

Every designing engineer ought to have our Property Chart—costs three cents which you pay to Uncle Sam.

A TYPICAL ALSIMAG BODY IS No. 35

Heat Resistant (safe limit for const. temp.)	1000° C	Loss Factor	60 cycles 1.95% 10 M C 1.08%
Dielectric Constant	60 cycles 6.5 10 M C 6.0	Dielectric Strength	200 Volts per Mil
Power Factor	60 cycles30% 10 M C18%	Water Absorption	Extruded Material .02% Pressed Material .069%
Vol. Resistivity (220 v. 60 cycles) 75° F—.08			

*38th Year
of Ceramic Leadership*



FROM CERAMIC HEADQUARTERS

AMERICAN LAVA CORPORATION • CHATTANOOGA • TENNESSEE
CHICAGO • CLEVELAND • NEW YORK • ST. LOUIS • LOS ANGELES • SAN FRANCISCO • BOSTON • PHILADELPHIA • WASHINGTON, D. C.

of opposite phase for an advancing wave. The current of the reflected wave will therefore, at the termination, subtract from the current of the direct wave whereas the voltages will add. At a point a quarter-wave away from the line termination the voltage and current of the direct wave will be a quadrant later in phase and the voltage and current of the reflected wave will be a quadrant earlier in phase than at the point of termination. The voltage of the reflected wave will therefore now subtract from the voltage of the direct wave whereas the currents will add. The input, or series, resistance at a quarter-wave distance from the termination thus becomes the reciprocal of the resistance of the termination in respect to the characteristic impedance of the line.

If the terminating resistance is lower than the characteristic impedance of the line, there is a current deficiency instead of a surplus. The direction of the current of the reflected wave must then be additive to the current of the direct wave. In this case the voltage of the reflected wave subtracts from the voltage of the direct wave at the point of termination.

Reflection-free performance of the line can thus be obtained by placing a resistance in parallel with the line at any point where the input or series resistance of the line is a maximum. At a point where the series impedance of the line is a minimum, the parallel resistance would have to be negative.

If now, instead the line is matched by resistance at the termination and a shunt reactance is added at this point, the resultant voltage and current will be out of phase with the resistive component and out of phase quadrature with the reactive component. The voltage and current of the reflected wave will therefore not be in phase quadrature with the voltage and current of the direct wave. The phase reversal at a point a quarter-wave from the termination thus results in impedance which is not only reciprocal in polarity but also in magnitude. Equal magnitudes obtain at distances which differ from a quarter-wave. If the reactance is inductive the distance for equal magnitudes is greater than a quarter-wave and smaller if the reactance is capacitive. Due to the polarity reversal it can thus be seen that identical shunt reactances, properly spaced, may be made to completely cancel each other's reflection effect in that one forms the parallel tuning counterpart to the other. If the reflecting reactance is small the distance between a pair of canceling shunt reactances becomes practically equal to a quarter-wave.

This principle can be practically util-

Fig. 3. Coaxial end section enclosed in coaxial container.

Fig. 4. Another coaxial connection. See text.

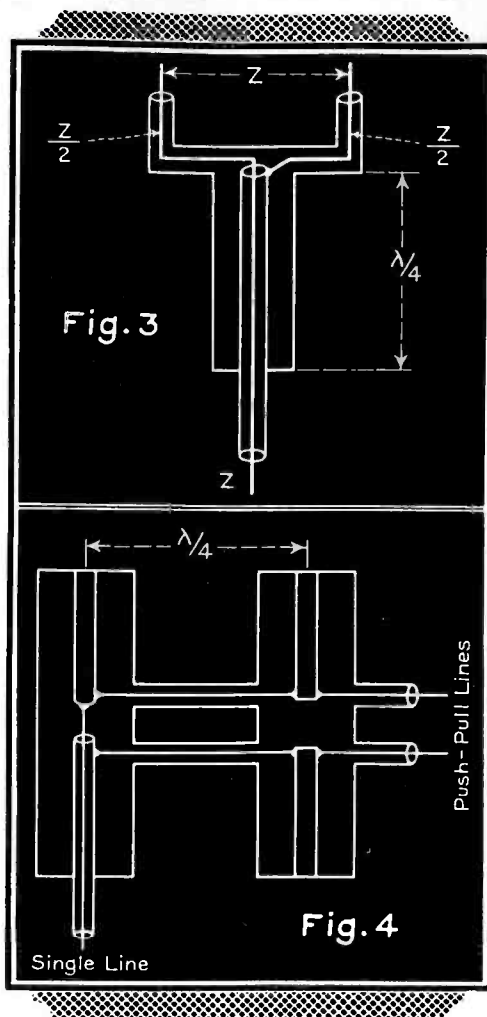

ized with great profit in the placing of the insulators for supporting the center conductor of a coaxial line. If such insulators are located at random they may cause serious cumulative reflection effects. If, on the other hand, they are placed in pairs with a separation, within a pair, of nearly a quarter-wave, the resultant insulator effect becomes negligible.

The phenomenon of reciprocal relationship between the series impedances of a line at points an odd multiple of a quarter-wave apart has been utilized in the so-called quarter-wave impedance transformer. In a case where it is necessary to continue a line into another line of different characteristic impedance, voltage and current distribution of undisturbed proportionality, in respect to the characteristic impedances of the lines, may be maintained by inserting a quarter-wave line section in series with the two lines having a characteristic impedance equal to the geometric mean between the characteristic impedances of the two lines. The characteristic impedance of the link is then equal to the square root of the product of the desired impedances at the two ends. A special case of this general principle is the matching of a line by a resistive load which does not equal the characteristic impedance of a line.

It is obvious that such transformation can be made in several stages. In the case of wide frequency bands this is even desirable, since the total electromagnetic storage in a cascaded transformer is less than that of a single quarter-wave link. The reflection caused at frequencies not corresponding to the length of the transforming links then becomes less. A transformer made up of many cascaded quarter-wave links can be replaced by a tapered line, which then if sufficiently long forms the most ideal type of impedance transformer.

The fact that the voltage and current phase varies from point to point along a line on which standing waves are present makes it possible to compensate for the reflection at any point on the line for a particular frequency by shunting or inserting a circuit of proper reactive and resistive characteristics. Usually it is not desirable to use compensating resistances. A point can always be found on the line at which the resistance will equal the characteristic impedance of the line if the reactive component is tuned by a counter reactance. For effectiveness over widest possible band this counter reactance should then be located at the point nearest to the source of reflection at which such compensation can be carried out. A simple form of counter reactance is a line section of proper length connected to the line in T-fashion. Regardless of the characteristics of the source a reflection can always be trapped by inserting an impedance transformer at the maximum or minimum point of the standing wave, since the series impedance of the line at such a point is resistive. This procedure is, however, usually less convenient than using the T-connected reactance.

It is sometimes desirable to branch a transmission line into two branches of different lengths so that a particular phase difference may be obtained between their terminations when each line is matched. The two most commonly desired differences are phase quadrature and phase opposition.

When phase quadrature is desired, the branches must obviously differ in length by a quarter-wave. If the branches have equal characteristic impedances and are matched, they may be supplied from a common line of half the characteristic impedance of each branch. The common line will then be matched.

If there should be any reflection, and if this reflection is equal on the two lines, the input impedance of each at the branching junction will become the reciprocal of the other in reference to the characteristic impedance of the branch lines. The input impedance into the junction of two lines differing in

(Continued on page 18)

PLUG-IN High Fidelity Audio Units

UNIFORM FROM 40 TO 15,000 CYCLES
EXCEPT ITEMS CARRYING DC

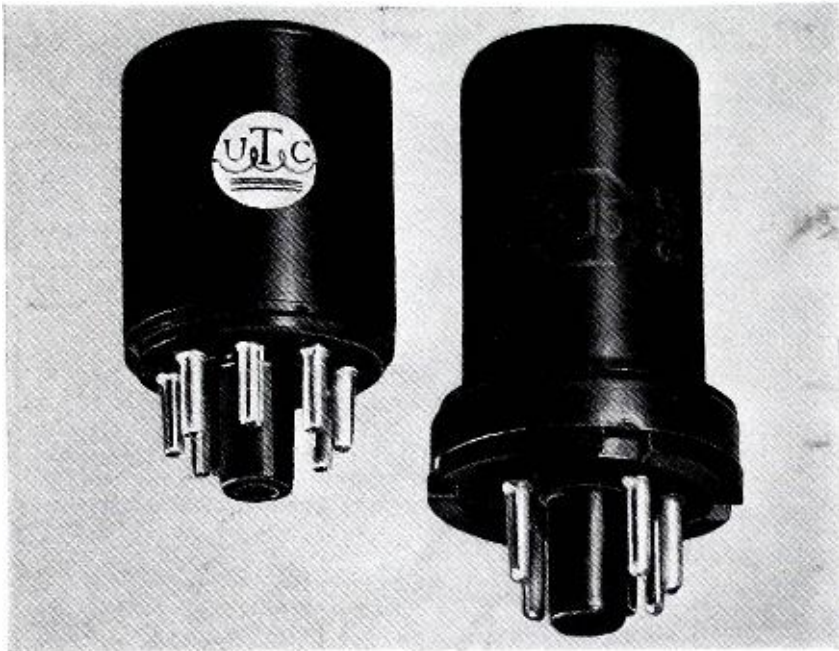

Microphone Cable Transformers

The UTC cable transformers are designed to be inserted in the cable circuit, and are ruggedly constructed to withstand mechanical abuse. The cable connections (supplied less cable) are made through the spring strain relief to terminal boards inside the end caps. These units may be located any place on the cable within twenty-five feet of the amplifier. 1 1/2" diameter . . . 2 1/2" long . . .

Type MC-1 primary tapped 30/50 and 200/250 ohms, secondary to grid, standard fidelity. Net **\$4.50**

Type MC-2 primary tapped 30/50 and 200/250 ohms, secondary to grid, high fidelity. Net **\$6.00**

Type MC-3 crystal microphone to 50/200 ohm line. Net **\$6.00**

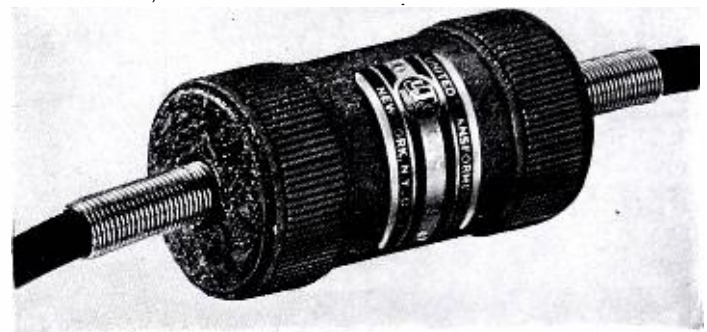

UTC has been producing Plug-In transformers for audio service for the past three years. The new "P" series is the final culmination of this development. These units have identical characteristics to the popular UTC Ouncer* transformers, and weigh only two ounces. Units not carrying D.C. have high fidelity characteristics, being uniform from 40 to 15,000 cycles. Items with D.C. in pri. and O-14 and O-15 are for voice frequencies from 150 to 4,000 cycles. They are of submersion proof design and fit standard octal sockets. The low weight and oversize pins used make it impossible to dislodge these units from their sockets, even when used upside down in portable equipment. Overall dimensions are 1 1/8" diameter . . . height exclusive of terminals—1 1/2".

PLUG-IN High Fidelity Audio Units

(MAX. LEVEL 0 DB)

200 ohm balanced winding may be used for 250 ohms.

Type No.	Application	Pri. Imp.	Sec. Imp.	Net Price
P-1	Mike, pickup or line to 1 grid	50, 200, 500	50,000	\$6.60
P-2	Mike, pickup or line to 2 grids	50, 200, 500	50,000	6.60
P-3	Dynamic mike to 1 grid	7.5/30	50,000	6.00
P-4	Single plate to 1 grid	8,000 to 15,000	60,000	5.40
P-5	Single plate to 1 grid, D. C. in Pri.	8,000 to 15,000	60,000	5.40
P-6	Single plate to 2 grids	8,000 to 15,000	95,000	6.00
P-7	Single plate to 2 grids, D. C. in Pri.	8,000 to 15,000	95,000	6.00
P-8	Single plate to line	8,000 to 15,000	50, 200, 500	6.60
P-9	Single plate to line, D. C. in Pri.	8,000 to 15,000	50, 200, 500	6.60
P-10	Push pull plates to line	8,000 to 15,000 each side	50, 200, 500	6.60
P-11	Crystal mike or pickup to line	50,000	50, 200, 500	6.60
P-12	Mixing and matching	50,200	50, 200, 500	6.00
P-13	Reactor, 200 Hys.—no D.C.; 50 Hys.—2 MA. D.C., 6,000 ohms			4.80
P-14	50:1 mike or line to 1 grid	200	1/2 megohm	6.60
P-15	10:1 single plate to 1 grid	8,000 to 15,000	1 megohm	6.60

*Our most copied line . . . yet never duplicated.

UNITED TRANSFORMER CORP.

150 VARICK STREET



NEW YORK, N. Y.

EXPORT DIVISION: 100 VARICK STREET NEW YORK, N. Y. CABLES: "ARLAB"

PERFORMANCE EFFICIENCY Go Up with Lingo

Photo shows the 294' Lingo Radiator at CJKL, Kirkland Lake, Ontario, Canada. A similar installation was made at CKGB, Timmons, Ont., also owned by Northern Broadcasting Co., Ltd.



LINGO—for the utmost in antenna performance

The ever-increasing number of Lingo installations is evidence that engineers recognize the high efficiency these radiators make possible. They are constructed entirely different from the conventional structural steel towers and are designed for a wind velocity of 100 m.p.h. The cross-section is uniform, circular and narrow throughout and the non-rusting guys have no deleterious effect whatsoever. The standard base insulator and the special automatic static drain guy insulators insure safe insulator design for powers as high as 500 KW. Painting and maintenance costs are about **one-fourth** that of a structural type tower. These facts are important to you.

We will be glad to make a free survey and give you the facts as they apply in your own case. In writing please give location, power and frequency of station.

JOHN. E. LINGO & SON, Inc.
Dept. C-5 CAMDEN, N. J.



TELEVISION ANTENNAS

(Continued from page 16)

length by a quarter-wave and having equal reflection will therefore be that of a pair of reciprocal impedances in parallel.

For a certain voltage at the junction, the volt-amperes fed into the branches will be inversely proportional to their input impedances at this point. If the reciprocity factor of these impedances in respect to the characteristic impedance is (a), the impedance of one branch will be multiplied by (a) and the other will be divided by (a). The reciprocity factor in reference to the characteristic impedance of the main line which obtains from the impedance variation in the branches may be called (b). In this discussion it is assumed that the branches have equal characteristic impedance. The characteristic impedance of the main line thus becomes half of the characteristic impedance of one of the branches. The parallel impedance at the junction is then equal to the characteristic impedance of the main line multiplied or divided by the reciprocity factor (b).

The volt-amperes into each branch equals the square of the voltage at the junction divided by the input impedance of the branch. The sum of the volt-amperes into the two branches equals the square of the voltage divided by the parallel impedance of the branches. When solving this simple equation

$$\frac{E^2}{Za} + \frac{E^2}{Z} = \frac{E^2}{2b} \quad \text{or} \quad \frac{E^2}{Za} + \frac{E^2}{Z} = \frac{E^2}{2}$$

$$b = \frac{a^2 + 1}{2a} \quad \text{or} \quad b = \frac{2a}{a^2 + 1}$$

the value of (b) expressed in terms of (a) is obtained. When taking the quotient of the difference between (b) and unity and the sum of (b) and unity

$$K_{EI} = \frac{b-1}{b+1} = \frac{\frac{a^2+1}{2a} - 1}{\frac{a^2+1}{2a} + 1} = \left(\frac{a-1}{a+1}\right)^2 \quad \text{or} \quad K_{EI} = \frac{b-1}{b+1}$$

$$= \frac{\frac{2a}{a^2+1} - 1}{\frac{2a}{a^2+1} + 1} = -\left(\frac{a-1}{a+1}\right)^2$$

it will be found that the coefficient of volt-ampere reflection on the main line

You and your associates can obtain a year's subscription to **COMMUNICATIONS** (12 issues) for only \$1.00 each by using the Group Subscription Plan.

A regular yearly subscription to **COMMUNICATIONS** costs \$2.00 — but when four or more men sign up at one time, each one is entitled to the half-price rate. (Foreign subscribers on the "G-S-P" only pay \$2.00 each).

COMMUNICATIONS

19 E. 47th St., N. Y. C.

Please enter annual subscriptions (12 issues) for each of the undersigned for which payment is enclosed at the rate of \$1.00 each. (This rate applies only on 4 or more subscriptions when occupations are given.) Foreign Subscriptions are \$2.00 each.

Name

Street

City-State

Occupation or title

Employed by

Nature of business

(State if Manufacturer, Broadcast Station, etc.)

Product

Name

Street

City-State

Occupation or title

Employed by

Nature of business

(State if Manufacturer, Broadcast Station, etc.)

Product

Name

Street

City-State

Occupation or title

Employed by

Nature of business

(State if Manufacturer, Broadcast Station, etc.)

Product

Name

Street

City-State

Occupation or title

Employed by

Nature of business

(State if Manufacturer, Broadcast Station, etc.)

Product

equals the square of the coefficient of volt-ampere reflection on the branch lines. Since this coefficient is always of sub-unity value, it is evident that the reflection on the main line becomes smaller than the reflection on the branches, Fig. 1. The actual values of the amplitude reflections will, of course, equal the square root of the volt-ampere reflections.

In like manner, the reflection on the main line may be estimated for any number of branches of various lengths if the relationship between their input impedances in respect to their characteristic impedances is known. A notable combination results when three branches are made of such relative lengths, versus the wave length, that they will deliver three-phase output when fed from a common main line.

In general, maximum reduction of coefficient of reflection occurs in the phase quadrature case. There is no reduction in coefficient of reflection for a pair of branches differing in length by a half-wave or multiple thereof.

Besides designing lines and line connections for minimum reflection, many other considerations enter in when attempt is made to provide maximum efficiency and utility. Only brief reference to a few of these considerations is justified within the scope of this article. It should be noticed that these references are only concerned with coaxial lines.

Optimum power transfer efficiency of a coaxial line is obtained when the ratio between diameters of outer and center conductor equals 3.6. This ratio corresponds to a characteristic impedance of 77 ohms. Optimum power transfer ability, for a given outer conductor, is obtained when the ratio of the conductor diameters is 1.65, Fig. 2. This ratio corresponds to a characteristic impedance of 30 ohms and provides maximum ratio between power and voltage gradient. Since the transfer efficiency characteristic as well as the characteristic of the energy transfer ability do not deviate too greatly from their respective optimum values at conductor ratios intermediate those corresponding to the above mentioned optimum ratios, it is possible to strike an economic balance between operation and investment cost. This becomes increasingly important as the length of the line increases. A line having a conductor ratio of 2.5 corresponding to a characteristic impedance of 55 ohms provides a good compromise. Any compromise is, of course, conditional.

A frequently occurring problem is that of providing a suitable connection between a voltage balanced circuit or line and a single coaxial line.

This can be done by connecting a line to two branches differing in length

Live Broadcast or PRESTO Recording? SO LIFE-LIKE LISTENERS CAN'T TELL THE DIFFERENCE!



Presto Dual 8-A Turntable, choice of many leading radio stations

● Many stations now contract to take programs for delayed broadcast, because their crowded schedules won't permit them to broadcast the program as it comes over the wire line. They record from the line . . . broadcast when time is open.

The engineers responsible for recording these programs know that their Presto recordings bring in thousands of dollars in added revenue to their stations. They take pride in the fact that listeners cannot hear the slightest difference between their Presto recordings and programs broadcast direct from the wire lines or studio. That is why they insist on using the finest recording equipment and PRESTO Q DISCS, proven by every test to have the lowest surface noise and widest frequency response range of any disc made.

Illustrated is the Presto Dual 8-A turntable equipment recommended for radio stations. Recent installations include NBC, New York (4) . . . WOR, New York (4) . . . Department of Interior, Washington (3) . . . WTIC, Hartford . . . WGN, Chicago . . . Westinghouse Short Wave Stations, Pittsburgh . . . WBNY, Buffalo, NBC-Washington and WKBN, Youngstown (2 tables, each) . . . WHDH, Boston, WHO, Des Moines (1 each).

JUST OFF THE PRESS! Our new catalog gives complete performance data on the entire Presto line of recording equipment and discs. Send for your copy today!

**PRESTO EQUIPMENT USED BY
DEPARTMENT OF INTERIOR,
WASHINGTON, D. C.**



PRESTO RECORDING CORPORATION
242 West 55th Street, New York, N. Y.
World's Largest Manufacturers of Instantaneous Sound Recording Equipment

You HELPED US PERFECT THIS NEW RECORDER..!

The new F-26-3, just out, was perfected on the firing line. It meets the demands of engineers for a precision instrument, simpler to operate and easier to service:

Amazing new cutterhead and network with a frequency response flat to 8,000 cycles (also available to fit Unit 199 and 220 Recorders, Model 2)

- Instantaneous variation of pitch and direction of cut eliminate expensive feed screws—a Fairchild exclusive
- 16" dynamically balanced turntable with direct synchronous drive assures split-second timing
- Instant change from 78 to 33 1/3 r.p.m.
- New recording scale in minutes for all pitches and both OUT-IN and IN-OUT
- Floating motor mount eliminates all vibration.

SEND TODAY FOR LITERATURE

"... it had to satisfy Fairchild first"



FAIRCHILD

Sound Equipment Division

AERIAL CAMERA CORPORATION
88-06 Van Wyck Boulevard, Jamaica, L. I., N. Y.

"Mangrid"
GRID WIRE

Economy
with quality

"Mangrid"
made only by

WILBUR B. DRIVER CO.
NEWARK, NEW JERSEY



FIRE, INSURANCE and HEALTH Inspectors say "O.K.," instantly when electrical equipment, motors, production materials and plants are kept clean with the Ideal Super-Powered "3-in-1" Jumbo Cleaner.

Cleaning is done safely—no moist air to rot wire insulation; thoroughly removes dust, dirt, grit, bench litter and other harmful foreign matter.

IDEAL

JUMBO
"3-in-1"



ELECTRIC CLEANER

High velocity air stream (24,200 ft. per min.) insures superior cleaning action. Low pressure prevents damage to delicate parts. Vacuums or blows dirt out of hard-to-get-at places. Sprays paint, varnish, etc. Attachments available for all kinds of cleaning jobs. Other type Cleaners available to suit your every requirement.

ASK FOR FREE TRIAL DEMONSTRATION

Electrical Products Division

IDEAL COMMUTATOR DRESSER CO.
1062 Park Avenue Sycamore, Illinois
In Canada: Irving Smith, Ltd., Montreal, Quebec.

by a half-wave. The branch terminals will then be in phase opposition. Since impedance matching requires that each branch have twice the characteristic impedance of the single coaxial main line, the impedance between the two terminals of the branches will be four times that of the main line. Due to the considerable length difference of half a wave between the two branches, the phase opposition between the branch terminals cannot be maintained for large frequency variations.

A circuit of greater utility for providing voltage balance may be had by enclosing the quarter-wave end section of a coaxial line within a coaxial, cylindrical container, Fig. 3, so that the line is conductively bonded where it enters the container, but forms a free quarter-wave stub inside thereof. The outer conductor of the line, by virtue of quarter-wave resonance, then becomes free to assume whatever potential is called for by the conditions of the circuit to which it is connected.

If this line balance converter is called upon for the transfer of widely separate frequencies it is necessary to make the ratio between container and the outer conductor of the transmission line as large as practically possible. In this way the shunt effect developing between the free end of the outer conductor of the line and surrounding container at non-resonance, can be kept sufficiently high to prevent serious unbalance. No inherent impedance transformation takes place during transit through this circuit.

This converter, which represents a development made in connection with the work at the Empire State Building television station, has found many uses. It can be used as a connection between single coaxial lines and push-pull lines or in general as a central connection to a number of balanced circuits. It makes it possible to connect a number of single coaxial lines in series.

It should be noted that an equal shunt effect to that experienced by the outer conductor portion within the container may be added to the center conductor by connecting it to a duplicate of the stub formed by the outer conductor, Fig. 4. In this case the length of the container has to be extended to a half wave. The shunt reactance, coming into effect at off-resonance, then becomes equal for both terminals and no unbalance is experienced. The reactive effect, however, will cause some reflection at large frequency variations. It is then, of course, possible to connect a compensating dummy to the line at a proper distance. Such procedure will, however, hardly have to be considered if the ratio between container and outer line conductor is generous.

Greater precautions against reflection becomes increasingly necessary as the length of the line and the frequency sweep increases. As the frequency varies, the shifts in location of maxima and minima of a standing wave increase in a cumulative fashion with the distance from the source of reflection. It is therefore obvious that the impedance presented at the transmitter will shift between the reciprocal values of line impedance at a rate which is proportional to the length of the line and the frequency shift. If, on the contrary, the line is sufficiently short, the shift of position of the standing wave will not be great enough to present a complete progression of impedance variation.

This phenomenon must also be kept in mind when locating compensation circuits. If the compensation circuit is located too far from the source of reflection it will not compensate over a sufficiently wide frequency band. On the other hand great distance from the source of reflection will result in a repetition of the compensation phenomenon at frequency intervals proportional to the distance. If the characteristic between the intervals has a tendency only towards moderate mismatch a general improvement may be obtained.

It should, however, be borne in mind that lest transient phenomena occur the total system must have flat and resistive characteristics over a band at least as wide as that corresponding to the steepness of the wave fronts produced by the modulation.

Reflections whether from the steady state or from transients will, if again reflected upon the return to the transmitter, cause multiple images. If the multiple images are complete duplicates of the direct image they are caused by steady state reflections. If they are hollow outlines they are of transient character. Transient reflection means reflection while a circuit is building up to steady state. It is assumed that when the steady state is reached, there is no reflection. Images from such reflection will then only show outlines. An impulse so short that it does not well cover the double distance between the source of reflection and the compensating circuit will appear as a multiple image of pronounced intensity.

An impedance variation across the output of a transmitter will cause a variation in its power output and result in a corresponding distortion.

If the termination impedance formed by the transmitter, to the reflected waves returning over the line, equals the characteristic impedance of the line throughout the operating frequency band, the output of the transmitter will become nearly constant within the band unless the reflection is very high. The energy

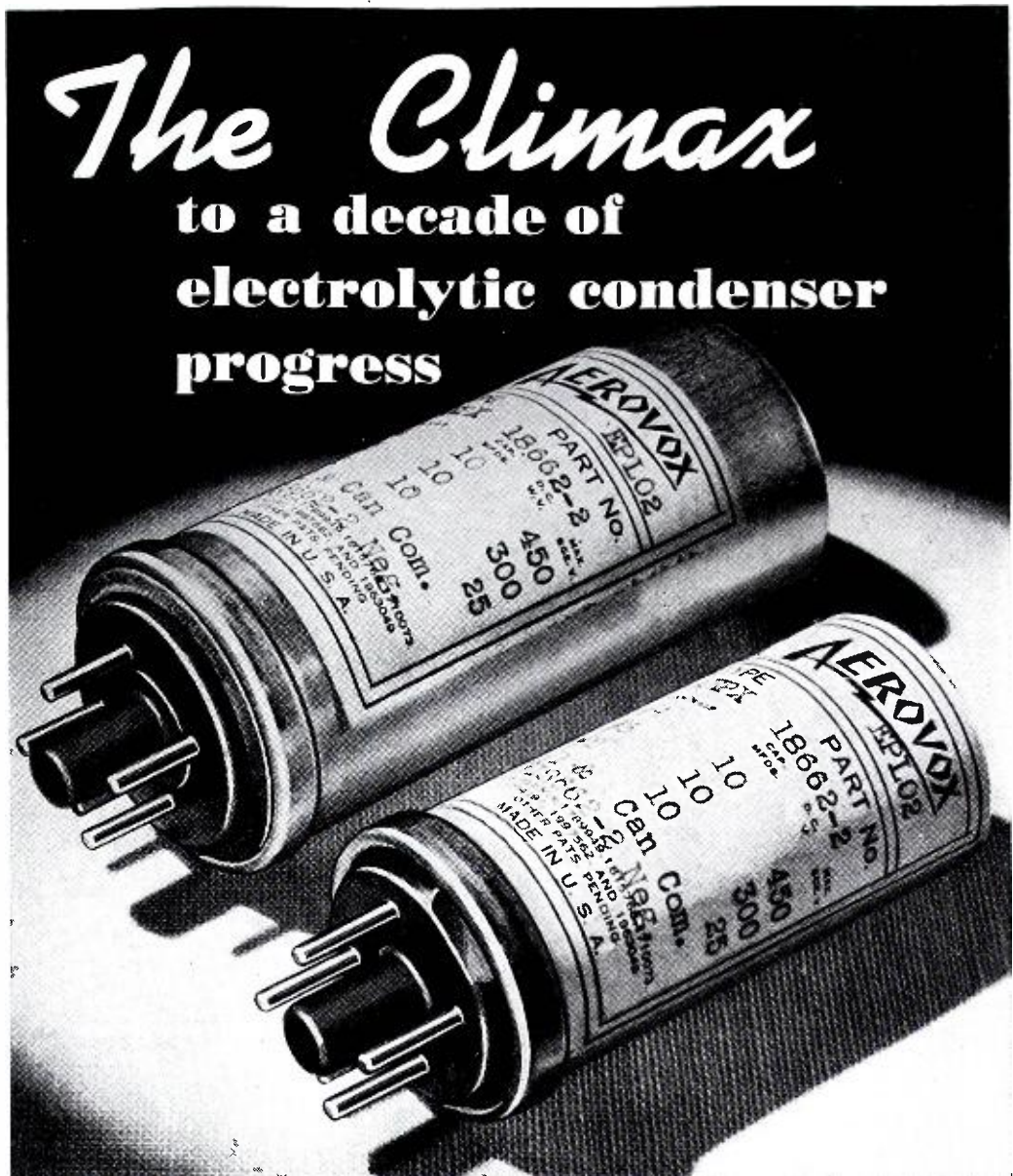

featuring . . .

Special octal base designed and made by AEROVOX, yet fits the usual standard octal socket.

Nickel-plated brass prongs engage with metal socket contacts of similar metal, for low-resistance, corrosion-free connections.

Junction of brass prongs and aluminum studs imbedded in molded bakelite, immune to corrosive effects.

Hi-purity aluminum tabs from electrolytic section bonded to aluminum studs of octal base, for corrosion-free aluminum-to-aluminum joints.

Hermetic sealing achieved by can edge spun over soft-rubber gasket and bakelite cover plug. Vented cover for full protection.

Available with plain foil and with etched foil. Two can sizes: 1 3/8" and 1 5/32" dia., 2 1/2" to 4 1/4" high. Single, dual, triple and quadruple section units. 25 to 500 v. D.C.W.

● AEROVOX rounds out ten years of electrolytic condenser pioneering with a brand new, startling, far-reaching contribution to the radio and electronic arts in the form of the Series AP Plug-In Electrolytic Condenser.

Developed primarily for the U. S. Signal Corps, and for use in aircraft, police-radio, sound-system and other equipment where continuity of service is a prime requisite, this idea opens up untold possibilities. Readily removed, tested, replaced, these octal-base condensers handle as easily as a radio tube or vibrator. Assemblies can be equipped with fresh plug-in electrolytics immediately prior to shipment or to actual use. Users can have "spares" on hand.

The many problems encountered in providing a tight, leak-proof, hermetically-sealed octal base, positively free from corrosion, have been fully solved. A perfected, practical, brand new class of condenser now becomes available to you.

Write for DATA . . .

● Engineering data, sample, quotations, cheerfully sent to responsible parties. Having fully tooled up for this type, the prices are fully in line with usual standard types of electrolytics.



AEROVOX CORPORATION

New Bedford, Mass.



Sales Offices in All Principal Cities

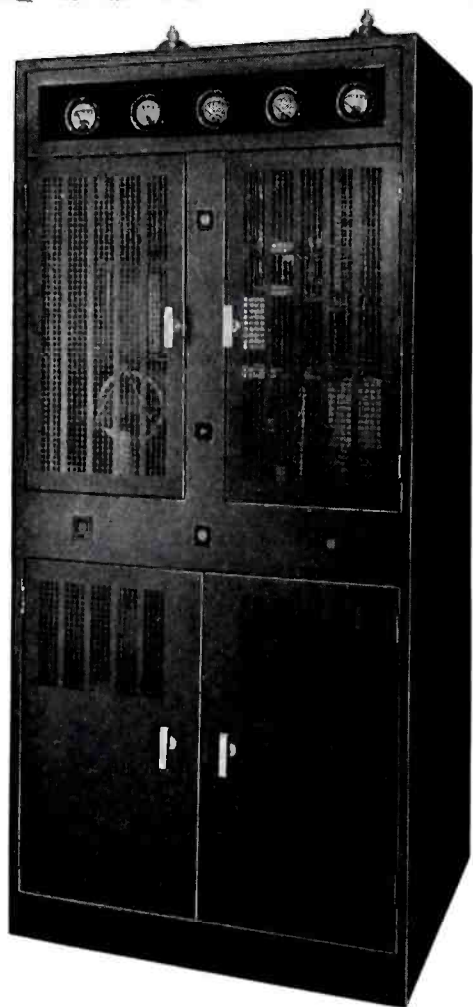

JOHNSON Phasing Equipment

When KMBC of Kansas City selected JOHNSON to build the phasing equipment for their new tower, it added another demonstration to the growing list of modern stations who have turned to JOHNSON for precision equipment of special design.

For 17 years, JOHNSON engineers have been designing and building apparatus to meet special problems and exacting requirements of broadcast and shortwave stations. This experience is particularly valuable now in view of the forthcoming frequency changes and the attendant opportunity to modernize transmitters and install directional antenna systems.

If you have a problem, write JOHNSON. Catalogs 301E and 966E free upon request.



E. F. JOHNSON CO.

WASECA, MINNESOTA

1900 - 25 WABNEY ST. MINN. 55083, U.S.A.

MANUFACTURERS OF RADIO TRANSMITTING EQUIPMENT

rejected at the end of the line is then absorbed by the transmitter upon returning over the line.

In general, therefore, the output of a transmitter becomes constant regardless of which end of the line is matched. The output of the line will then vary as the reflection varies at the output end of the line. The variability due to line length does, however, disappear.

The occurrence of multiple images, will not take place if either end of the transmission line is well matched and if there are no intermediate sources of reflection along the line. There are, however, certain difficulties connected with the matching together of line and transmitter.

The equivalent internal impedance of a transmitter must, of course, have a reasonably constant relationship to its loading impedance, within the operating frequency band. Variations in the power output, while undesirable, can, however, be tolerated to a certain degree.

If, on the other hand, there should be

a fairly substantial reflection from the antenna, a decrease in the ability of the transmitter to absorb the returning waves would result in the retransmission of the portion that the transmitter failed to absorb. A second image would thus obtain, which would be displaced from the primary image in proportion to the length of the line. Since even very small amplitudes of secondary impulses result in clearly distinguishable images, this condition is not acceptable.

Due to the appreciably intrinsic relation between such factors as emission, transit time and reactance in vacuum tubes, it is at the present next to impossible to provide a transmitter of sufficiently constant self impedance, over a wide band of frequencies, to provide satisfactory absorption of returning waves.

The radiation of multiple-free images therefore greatly depends upon the antenna and it becomes of cardinal importance that this structure cause very little reflection throughout the operating frequency band.

A large-screen theatre-type television system was demonstrated recently before the annual stockholders' meeting of Radio Corporation of America. This laboratory model projects images of 4½ by 6 feet on to an ordinary beaded motion picture screen. Built as an intermediate step in the development of larger screen equipment, the apparatus consists of three parts. One part contains kinescope projection tube. Another contains power supply, the third electrical circuits.

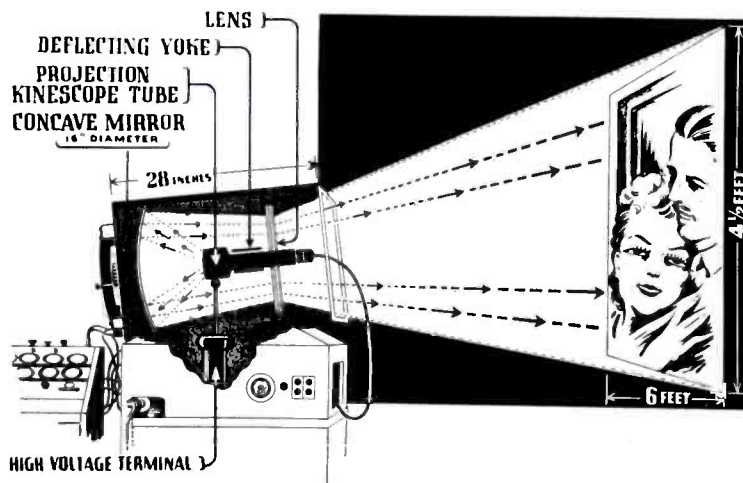

VOLTAGE DIVIDERS

(Continued from page 9)

both extremes. A point-by-point response curve similar to Fig. 2 may be plotted if desired. For relative great step-down ratios, a wide-band amplifier may be needed to bring the voltage up within the range of the voltage measuring device at hand. In such a case, the response characteristics of the amplifier alone will be needed.

A description of one typical problem encountered will make clear the necessity for a good understanding of the general attenuator principles outlined in this discussion. A wide-band, push-pull amplifier was constructed utilizing the usual phase-inverter tube whose grid was driven by a portion of the voltage appearing in the plate circuit of its mate. It was found necessary to balance this voltage-dividing circuit capacitively to avoid serious unbalance be-

tween the two sides of the push-pull system at the higher frequencies. The amplifier responded well to treatment once the basic trouble was understood.

References

(1) "Theory of Voltage Dividers and

IMPORTANT!

BE CERTAIN TO
ATTEND THE

**I R E
CONVENTION**

•
**HOTEL STATLER
BOSTON**

•
June 27-28-29

Their Use with Cathode-Ray Oscillographs," Peters, Blackburn, and Hannen, *Bureau of Standards Journal of Research*, Vol. 9, July, 1932, (Research Paper No. 460).

- (2) "An Oscillograph for Television Development," Stocker, *Proc. I.R.E.*, Vol. 25, No. 8, August, 1937, pp. 1012 to 1033.
- (3) "Oscillograph Design Considerations," Metzger, *Proc. I.R.E.*, Vol. 27, No. 3, March, 1939, pp. 192-198.
- (4) "Practical Aspects of Wideband Television Amplifier Design," Everest, *COMMUNICATIONS*, March, 1939, pp. 21, 22, 24, 38, 48, 49.

SATELLITE STUDIO

(Continued from page 11)

has allowed accurate and intelligent adjustment of the line equalizer during normal program breaks.

If in some locations of a temporary nature it is found that economy requires the locating of this equipment in the studio, advantage lies in the use of a split headset. Arrangements have been made so that one telephone receiver can be plugged into the radio receiver and one connected across the line which is being fed from the amplifier. Good monitoring can be obtained by this method with the advantage of an overall check on the studio equipment, the line to the main studio, the studio cueing procedure, etc. The use of this system by our station has at times prevented program blanks.

A word should be added concerning construction and testing of the assembly. Each amplifier was wired and tested individually with measurements being made of the frequency response, the inherent noise, and the overall gain. After the individual amplifiers were wired into the complete assembly, listening tests indicated a high audio peak at about 120 cycles. This was found to entirely disappear when the desk was removed from its saw horse supports and placed on the floor. Due to the front of the desk being used for a loudspeaker baffle, acoustic distortion occurred when the unit was placed some three feet above a smooth surfaced, sound reflecting floor.

Operation with this equipment in service over a period of more than a year has not indicated the desirability of any significant changes in its design or construction. Experience has shown also that errors are much less likely to occur with one position locking type keys being used for studio switching operations than with the two position locking type.

Simplicity and straight forward operation have constituted the keynote of design. Much thought was given to the psychology influencing the action of an operator working under stress, and the results have indicated that this feature is worth more consideration in the design of studio switching equipment.



- Noise level below microphonics.
- Excellent frequency characteristics.
- Low in price; small in size.
- Complete with dial, knob and shield.
- Now ready for immediate shipment.

Series LA-800

Ladder Network

Compact low impedance mixing controls for use in portable broadcast equipment and public address systems, similar in construction to larger and costlier units.

Because of the low price they may readily be adapted as mixer or master gain controls in popular priced systems. Outstanding advantages are: dependability of service, accuracy of control, noiseless operation, and constant impedance over a large part of the operating range.

Price \$5.75

20 Steps

SERIES	DECIBEL PER STEP	Attenuation	
		CHARACTERISTIC	DECIBEL TOTAL
LA-800	2.0	Tapered	Infinite
LA-801	1.5	Linear	Infinite
LA-802	2.0	Linear	Infinite
LA-803	2.0	Linear	40 Db.

Series CP-800

High Impedance Potentiometers

These are designed for use as gain controls in portable amplifiers and public address systems. They are rugged, compact, and are readily adaptable to popular priced systems. Long and trouble-free service can be obtained from this type of attenuator, thus eliminating the necessity of periodic replacement of the volume control.

Price \$5.75

20 Steps

SERIES	DECIBEL PER STEP	Attenuation	
		CHARACTERISTIC	DECIBEL TOTAL
CP-800	2.0	Linear	Infinite
CP-802	1.5	Linear	Infinite
CP-803	3.0	Linear	Infinite
CP-804	2.0	Tapered	Infinite

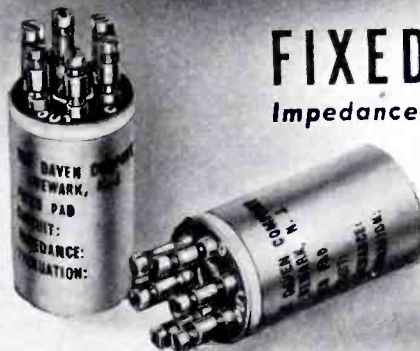

FIXED ATTENUATOR (Pads)

Impedances may be secured from 30 to 600 ohms.

"TEE" Network
 Type T950 \$2.50
 Size 11/16 x 1 5/8
 Overall Height

Balanced
 "H" Network
 Type H950 \$3.00
 Size 11/16 x 1 5/8
 Overall Height

WRITE FOR CATALOG

THE DAVEN COMPANY

158 SUMMIT STREET

NEWARK, NEW JERSEY

AIRCRAFT VIBRATION

(Continued from page 7)

IV—Practical Design Considerations

Based on the foregoing theoretical analysis, we shall formulate certain principles of design that have been found applicable to most practical conditions. The following preliminary data is required:

(a) Total weight of equipment to be mounted.

(b) Location of the center of gravity of the assembled equipment as mounted on the vibration-absorber assembly.

(c) Radius of gyration, i , of the total mass of equipment as mounted.

(d) The lowest frequency of vibration it is desired to insulate against.

Given the above data, we may proceed with the design of a suitable vibration-absorber assembly.

If at all possible, the plane in which the vibration-absorber units are located should contain also the center of gravity of the equipment to be insulated. When this is true there is no turning moment likely to develop about an axis in the plane of the mounting, and, therefore, no rotational mode of vibration set up. This greatly simplifies the design of the assembly because it is then only necessary to consider the compliance of the vibration-absorber units in the direction, and under the condition, of translatory vibration.

Assume, for example, that we desire to insulate against vibrations of all frequencies down to 10 cycles per second. From a practical standpoint this will be accomplished satisfactorily if we make B , in Fig. 2, equal to 1.0 at 10 cycles per second. Referring to Fig. 2, we see that the static deflection, ΔS required to accomplish this is 0.196 inches. Knowing the required static deflection of the vibration absorbers and the weight of the equipment to be insulated against vibration, we may easily deduce the required stiffness of the correct vibration-absorber units. Provided the mounting plane of the vibration-absorber units contains also the center of gravity of the assembled equipment no further basic design considerations are necessary.

With certain types of equipment, however, raising the plane containing the vibration-absorber units a sufficient amount to cause it to contain also the center of gravity of the equipment requires the use of a considerably larger mounting area than would be necessary if the vibration-absorber units were placed directly beneath the equipment. This is illustrated in Fig. 4, which indicates a dynamotor unit supported both by a sub-center-of-gravity type and a center-of-gravity-type mounting. The possibility of conserving mounting area through the use of the sub-center-of-

gravity mounting is obvious. It should be noted, however, that, where the sub-center of gravity type of mounting is used, it is important to adjust the distances r_1 , r_2 , and r_m so that $r_1 = r_2 = r_o$, and $r_o^2 = r_m^2 + i^2$. It is also very desirable to use vibration-absorber units of such physical construction and composition that their stiffnesses are the same in all directions and to symmetrically locate them with respect to the center of gravity of the equipment.

The sub-center-of-gravity type of mounting is, however used, inherently unstable and the center-of-gravity type is always preferable unless practical conditions make its use impossible. Mounting space can often be conserved by using a single mounting to support several related units of equipment. In this way center-of-gravity type mountings may be used and, at the same time, the total required mounting space kept to a minimum. This construction is illustrated in Fig. 5 where a single center-of-gravity type mounting is used to support a vacuum-tube amplifier and dynamotor units.

Where space is available for mounting several related units of equipment (such as the radio receiver, transmitter, and power-supply units) together in one location, a very effective type of center-of-gravity mounting to apply is indicated in Fig. 6. The entire assembly is mounted by securely fastening to the airplane structure at the points marked "X".

The vibration-absorber units themselves may be metallic springs or suitably treated rubber. Springs have several disadvantages. They do not lend themselves readily to compact designs, are not easily damped or snubbed, and become complicated when designed for uniform stiffness in all directions. Suitable rubber units, on the other hand, may be obtained in very compact designs, their total movement is readily limited without detriment to the vibration-absorbing action and they may be arranged, with little difficulty, to give fairly uniform stiffness in all directions. For these reasons, properly designed rubber units are preferable for mounting most aircraft radio equipment. The rubber used in the fabrication of such units should be treated to withstand, without any serious change in stiffness or other deterioration, ambient temperatures between -40° C. and $+70^\circ$ C. (-40° F and $+158^\circ$ F), salt spray, oil-and-water spray, and the continuous application, over long periods of time, of the normal amplitudes and frequencies of vibration it is desired to insulate against.

CORRECTION

An error appeared in the article "A

Light-Pattern Calibration Chart" published on pages 24, 25, 26 of the April 1940 issue of COMMUNICATIONS. Equation (5), page 25, should read

$$\text{Recorded level (db)} = 20 \log \frac{W}{W_0}$$

OVER THE TAPE

MANUFACTURERS' AGENT

Mr. Thomas C. Jenkins, Johannesburg, South Africa, will arrive in New York about the middle of May. He is arranging to establish himself as manufacturers' agent for South Africa and is seeking representation of reliable American and Canadian manufacturers. While in this country Mr. Jenkins will make his headquarters with Wilbur B. Driver Company, Newark, N. J.

ELECTRICAL INDUSTRIES APPOINTMENT

The Electrical Industries Mfg. Co., Inc., Red Bank, N. J., manufacturers of Leach Recorders, has appointed E. Friedenbergl as General Sales Manager. Mr. Friedenbergl has been connected with the radio industry in various sales and merchandising capacities for the past 15 years.

CHANGE OF NAME

The corporate title of the Eisler Electric Corporation has been changed to Callite Tungsten Corporation, it was announced recently by Charles H. Kraft, President of the company. The organization is serving many industries with both materials and equipment for the manufacture of incandescent lamps, neon signs, radio tubes and other types of electronic devices.

GOLENPAUL-AEROVOX ANNIVERSARY

An outstanding tieup in the radio trade, Golenpaul-Aerovox, will celebrate its tenth anniversary by the time the Radio Parts Show rolls around. It was ten years ago that Charley Golenpaul joined Aerovox Corporation and started building up its jobber sales from virtually nothing to a gigantic business. He has been most active in jobber, service and ham organizations, and in other groups and movements as well.

EARL WEBBER BOOKLET

Just off the press is an 8-page booklet, titled the "Blue Book of Instrument Values," which has been prepared by the Earl Webber Co., 4358 W. Roosevelt Rd., Chicago, Ill. A copy will be sent without charge.

CLAROSTAT APPOINTMENT

To provide better application of engineering service for radio manufacturers and industrial users of resistors, controls and resistance devices, Clarostat Mfg. Co., Inc., Brooklyn, N. Y., announces the appointment of Frank Murphy as its sales engineer in the Chicago area. Mr. Murphy has an extensive background of manufacturing and engineering experience in the radio, electrical and industrial fields generally.

JOHN MECK BOOKLET

Every day problems in layout and connection of speaker systems are covered in a new booklet, prepared by John Meck Industries, Randolph at Elizabeth Sts., Chicago, Ill. A copy will be sent without charge to any radioman interested in sound work.

CINEMA ENGINEERING EXPANDS

The Cinema Engineering Company, Burbank, Calif., announces the appointment of Norman B. Neely as exclusive sales representative. This company has been supplying precision attenuators and resistors, plugs and patch cords, relays, jacks, jack strips, gain sets and similar units to the motion picture industry for several years. Mr. Neely's appointment marks the beginning of an expansion campaign made possible by increased manufacturing facilities. A new catalog has just been released and is available upon request to Norman B. Neely, 5334 Hollywood Boulevard, Hollywood, Calif.

HARVEY-WELLS BULLETIN

An attractive and interesting folder on 1940 ship radiotelephone equipment has just been issued by Harvey-Wells Communications, Inc., Southbridge, Mass. This folder describes new 25 watt, 10 watt and portable models. Write for Bulletin MR-40.

REX RHEOSTAT CATALOG

The Rex Rheostat Co., 37 W. 20th St., New York City, have recently made available Catalog R covering their line of special resistors and rheostats. Copies of the Catalog may be obtained by writing to the above organization.

IRE CONVENTION

THE Fifteenth Annual Convention of the Institute of Radio Engineers will be held at the Hotel Statler, Boston, Mass., on June 27, 28 and 29. While the complete program has not yet been made available, a general program has been arranged. It is given below:

Thursday, June 27

- 9:00 A.M. Registration
- 10:00 A.M. Technical session, welcome by the president.
- 1:30 P.M. Trips to Raytheon, General Radio, Harvard's Cruft Lab., M. I. T., Hygrade Sylvania in Salem, Marblehead.
- 8:00 P.M. Technical session with demonstrations on ultra-high frequency at M. I. T.

Friday, June 28

- 10:00 A.M. Technical session, general.
- 2:00 P.M. Technical session on aviation radio. Technical conference on rating of transmitting tubes.
- 7:30 P.M. Banquet.

Saturday, June 29

- 10:00 A.M. Technical session, general.
- 2:00 P.M. Technical session on frequency modulated systems.
- 4:30 P.M. Trip to Yankee Network frequency modulated transmitter and supper atop Mt. Asnebumskit at Paxton.

The Convention Committee, which appears to be doing an excellent job, consists of the following members:

Chairman, W. L. Barrow, Mass. Inst. of Tech.; Vice Chairman, E. L. Bowles, Mass. Inst. of Tech.; Budget and Finance, P. K. McElroy, General Radio Company; Program and Arrangements, C. E. Tucker, Mass. Inst. of Tech.; Trips, Henry Lane, Presto Recording Corp.; Registration and Information, Rudolph Oberg, Northeastern Univ.; Banquet and Entertainment, J. M. Henry, New England Tel. & Tel.; Women, Mrs. D. B. Sinclair; Exhibition, John D. Crawford, I. R. E. Headquarters; Papers, H. A. Pratt, care I. R. E. Headquarters.

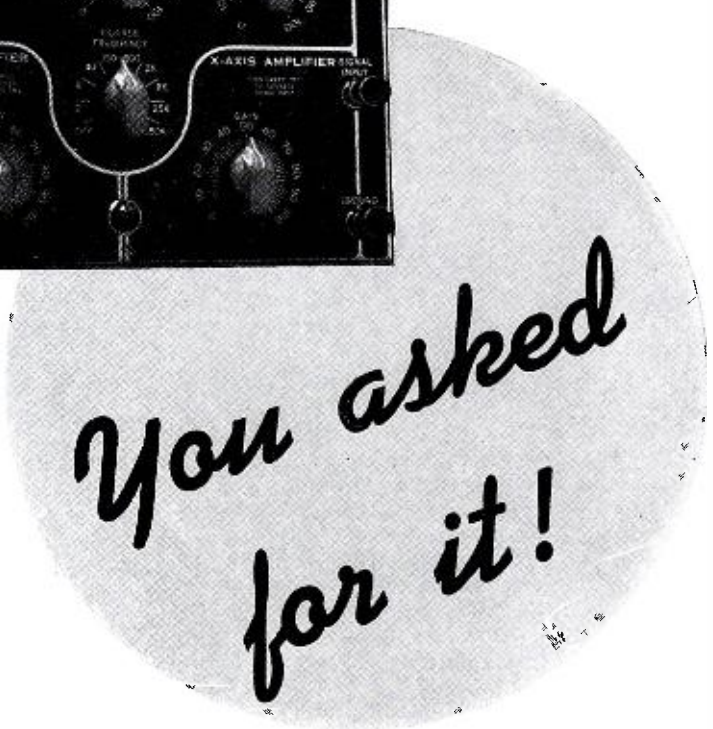
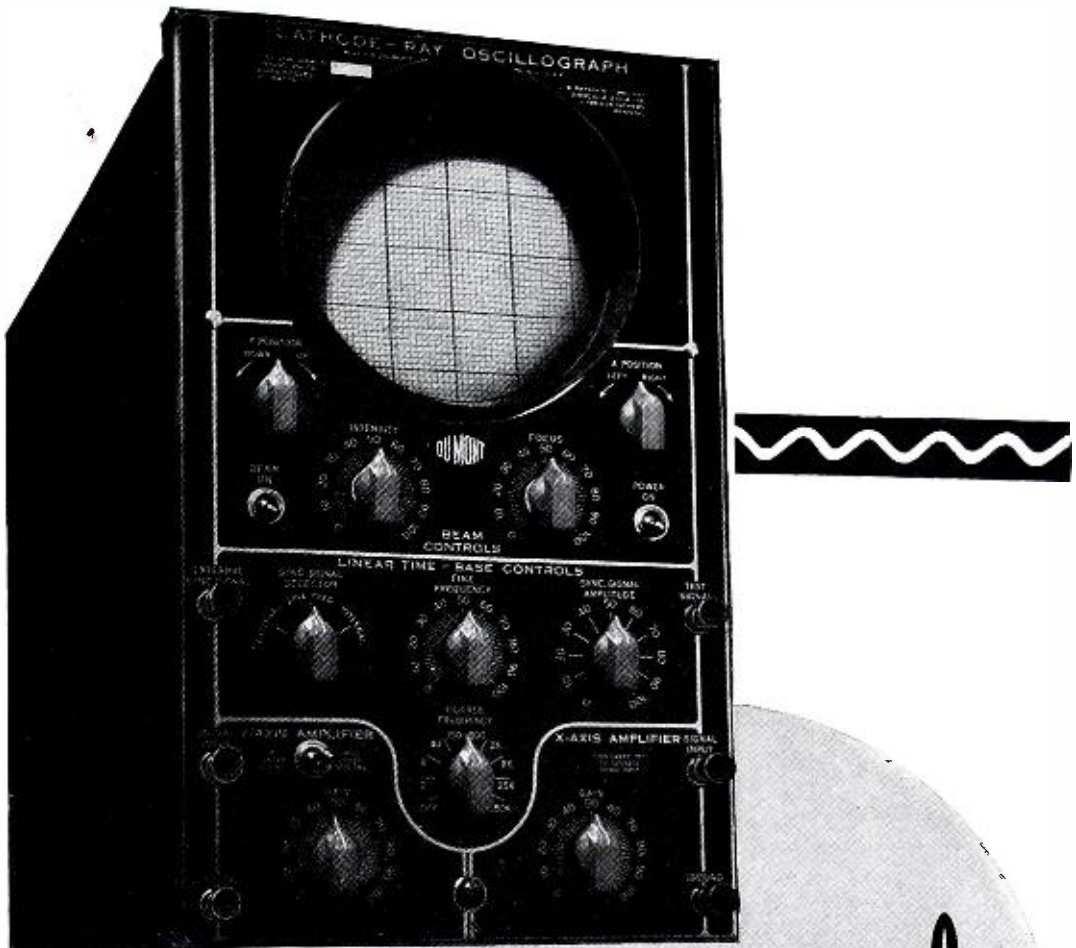

Constant-impedance, continuously-variable input attenuator — zero frequency discrimination.

A handsome, rugged, readily portable instrument for use in the laboratory, shop and field.

Four easily-accessible deflection-plate terminals.

Beam switch.

Symmetric deflection of both axes for fine focus and no distortion.

Undistorted four-cycle square-wave response.

Flat to 100,000 sinusoidal cycles per second.

Sweep frequencies from 2 to 60,000 cycles per second.

Instantaneous position circuits. Spot may be immediately positioned to any point on the screen.

Regulated power supplies — no pattern drift.

Nearly fifteen-inch time-base, with 2½ times full-scale deflection.

New functionally-designed front panel. Controls cleverly grouped according to circuit arrangement and general functions.

Unique chassis construction providing balanced electrical and mechanical design, and balanced weight distribution for ready portability.

Dimensions: 14½" high, 8-13/16" wide, 19½" deep. Weight 54 lbs.

Positively built like a battleship.

★ And so Du Mont is proud to announce a new cathode-ray oscilloscope which sets a new "high" for such equipment. It is the direct result of the closest cooperation with engineers in many fields, plus a detailed study of the requirements of their respective industries.

The Type 208 Cathode-Ray Oscilloscope is replete with features which will make your work easier and more pleasant, which will extend your investigations into studies not previously feasible without much labor and expense; and, because of its outstanding engineering and completeness, this instrument will leave some money in your budget for other needed equipment.

Detailed data describing this radically different instrument is now ready. Your name and address are all we need.



THE MARKET PLACE

NEW PRODUCTS FOR THE COMMUNICATIONS FIELD

THREE-PHASE VARIACS

General Radio Type 50 Variacs (5-kw size) can now be provided in 2- and 3-gang combinations for use on three-phase circuits, and with current-equalizing chokes

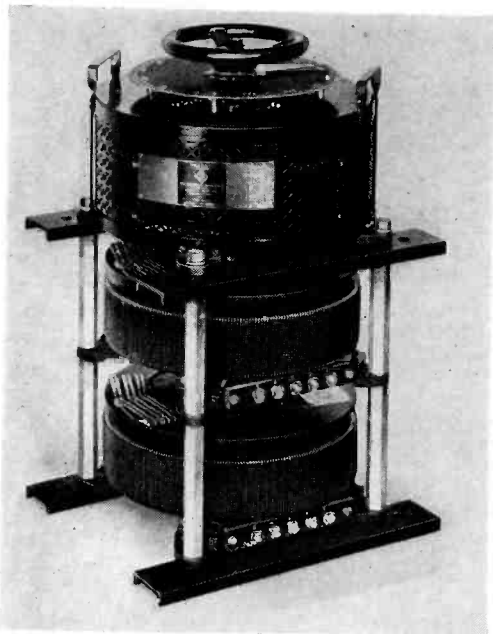

for parallel operation on single-phase circuits. Both 115- and 230-volt models are available. The 230-volt, 3-gang unit can be used in the wye connection on 560-volt circuits to obtain continuously variable output voltages from 0 to 560 volts with a maximum output of 30 kva. General Radio Co., 30 State St., Cambridge, Mass.

PLUG-IN ELECTROLYTICS

Plug-in electrolytic condensers are now being made generally available by Aerovox Corporation, New Bedford, Mass. Handling with the ease and speed of radio tube or vibrator changes, the plug-in feature permits an electrolytic condenser to be instantly removed without tools or trouble, for testing and replacement. Developed primarily for the U. S. Signal Corps, the plug-in electrolytic has offered obvious advantages to aircraft, police-radio and sound-system equipment, and with its

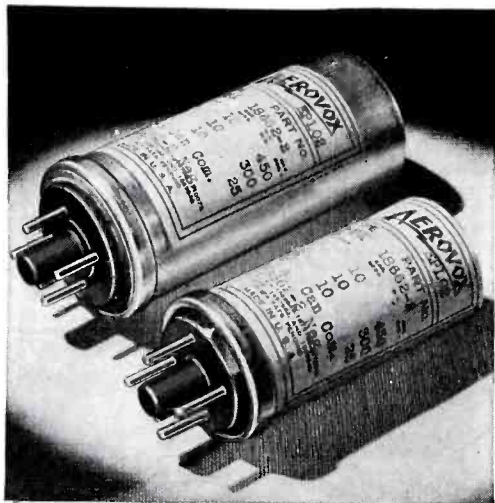

transition from custom-built item to standard condenser, the plug-in type can provide many possibilities in home and auto radios as well. Aerovox is now tooled up for the mass production of this type, bringing the cost down to the level of conventional electrolytics, it is said.

VARI-X

The Bliley Vari-X, with VF2 Crystal Unit, combines full quartz crystal stability with the frequency flexibility of a self-excited variable oscillator. Engineered for operating convenience, this crystal controlled variable frequency exciter is easily



placed in service. Output is obtained on 40 or 80 meters simply by rotating the tuning knob and watching the electric eye for resonance. Either crystal is instantly chosen by a convenient selector switch. Literature may be secured from the Bliley Electric Co., Union Station Bldg., Erie, Pa.

SPOT WELDER

The Eisler Engineering Co. has introduced a 5-kva high-speed production spot welder. This welder is an air operated,



vertical press type machine supplied with a suitable automatic timer and contactor. There are two operators for this welder, one to load the welding fixture and the other to operate the foot switch and slide.

the fixture along after each weld. Eisler Engineering Co., 740-770 So. 13th St., Newark, N. J.

KENYON PLUG-IN TRANSFORMERS

Kenyon Transformer Co., Inc., 840 Barry St., New York City, have announced a new series of plug-in transformers in both standard and submersion proof types. Cases are of alumilite, 2 1/8 by 1 1/2 in. in diameter and are provided with an 11-prong base similar to the octal type. 21 types are available to cover a wide variety of applications. Additional informa-

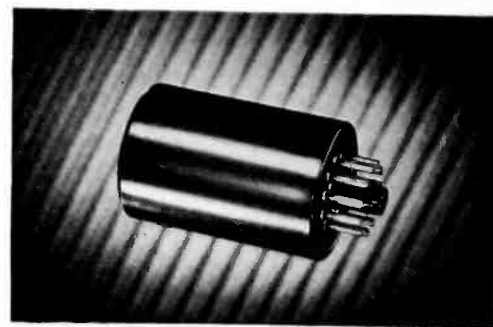

tion and prices may be obtained directly from Kenyon.

BROADCAST TRANSMITTERS

The Gates American Corp., Quincy, Ill., announce the addition of two new models of commercial broadcast transmitters recently approved by FCC. These transmitters include the Model S101 for 100 watts operation and the S251 for either 250 watts or combined 100-250 watts service. Complete brochure on these new equipments available on request.

POWER TAP-SWITCHES

New increased ratings have been set for each of the five Ohmite high-current tap switch models. Model 111 is now rated at 10 amps, 150 volts ac; Model 212 at 15 amps, 150 volts ac; Model 312 at 25 amps,

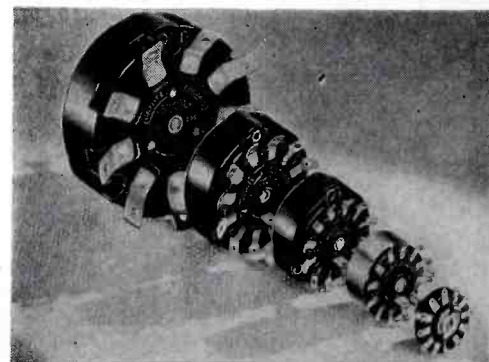

300 volts ac; Model 412 at 50 amps, 300 volts ac; and Model 608 at 100 amps, 300 volts ac. These ratings apply to alternating current circuits operating at any power factor. For complete information write Ohmite Mfg. Co., 4835 Flournoy St., Chicago.

BLILEY CRYSTAL UNITS

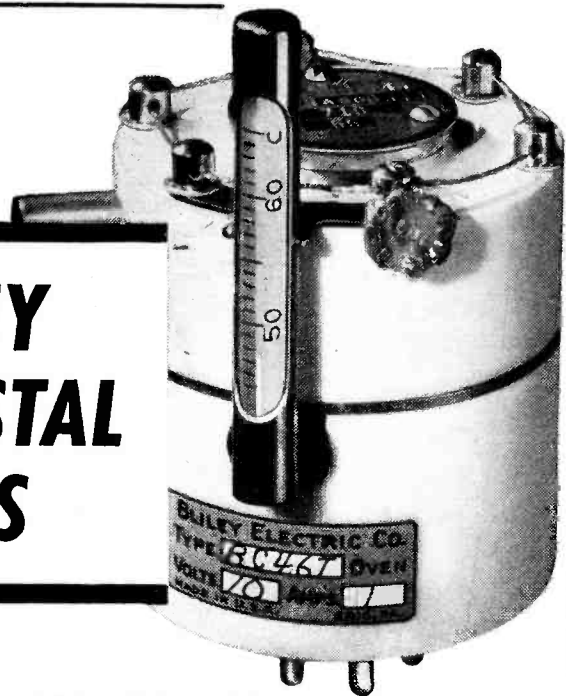

PRECISION BUILT
FOR *dependable* OPERATION

Bliley Broadcast Crystals and Ovens meet all F.C.C. requirements. Write for Catalog G-11 describing complete line.

BLILEY ELECTRIC COMPANY

UNION STATION BUILDING

ERIE, PA.

ONAN ELECTRIC PLANTS

SERIES
OTC

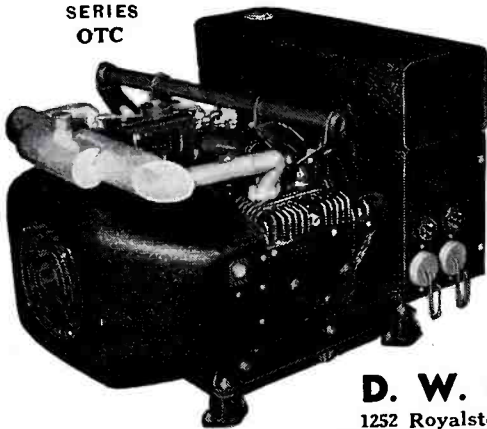

ONAN A.C. ELECTRIC PLANTS are used by Radio Operators all over the world for primary or Emergency power supply.

40 DEPENDABLE MODELS 350 to 10,000 watts, ready for immediate shipment and operation.

LIGHTWEIGHT, COMPACT PLANTS for Mobile, Pickup, Transmitter Trucks. 1500 watt OTC, weight 120#; 4000 watt OTA, weight 200#.

Built by specialists in Electric Plant manufacturing for 14 years. 15,000 in operation on land, on sea, and in the air.

WRITE FOR DETAILS

D. W. ONAN & SONS

1252 Royalston Ave., Minneapolis, Minn.

PLAN TO ATTEND

the

NATIONAL

IRE CONVENTION

JUNE 27-28-29

HOTEL STATLER

BOSTON

**27-145 MEGACYCLE
RANGE
(11.1-2.07 METERS)
AMPLITUDE/FREQUENCY
MODULATION**



Model S-27 is the first general-coverage U.H.F. communications receiver to incorporate Frequency Modulation reception. Covers 3 bands: 27 to 46 mc; 45 to 84 mc; 81 to 145 mc. Switch changing from FM to AM reception. Acorn tubes in R.F. and newly developed converter system. High gain 1853 tubes in I.F. stages. Beam power tubes and 6C8G phase inverter in A.F. Amplifier. Limiter tube provides full limiter action on signals of approximately 5 to 10 microvolts in F.M. operation. 955 plate-tuned oscillator. I.F. selectivity automatically sharpened to receive amplitude modulated U.H.F. signals or broadened for wide band frequency modulated signals. Front panel controls: R.F. gain control. Band switch. Antenna trimmer. I.F. selectivity (air tuned iron core) control. Volume control. Pitch control. Tone control. S-meter adjustment (meter calibrated in S and DB units). AVC switch. Beat oscillator switch. Automatic noise limiter switch. Amplitude/Frequency Modulation switch. Send-receive switch. Phone jack.

the hallicrafters inc.
2601 SOUTH INDIANA AVENUE, CHICAGO, U. S. A.

WORLD'S LARGEST BUILDERS OF AMATEUR
COMMUNICATIONS EQUIPMENT

GENERAL UTILITY RESISTOR

A line of general-utility voltage-dropping resistors is announced by Clarostat Mfg. Co., Inc., 285-7 N. Sixth St., Brooklyn,

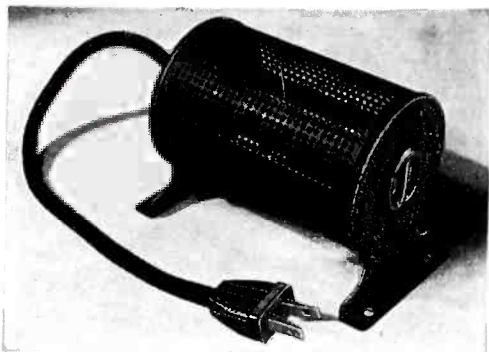

N. Y. Series HT units are now available in any resistance and wattage rating from 100 watts up. They can be used for any voltage-dropping or current regulating purpose.

EXTRUDED TUBING

A new development in plastic materials is an extruded tubing manufactured in con-

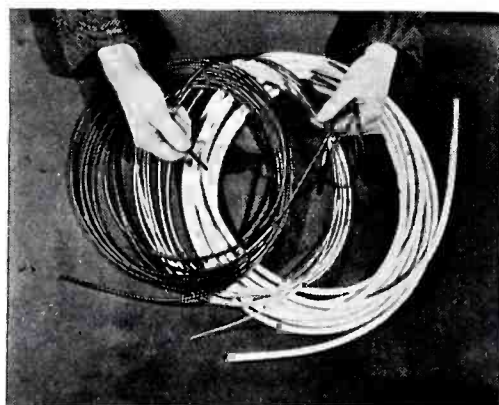

tinuous lengths and having characteristics of importance for its use in many indus-

MARINE RADIO—continued from page 12

sixty miles out on Long Island. Boston has similar "ears" as far down the coast as Newport, R. I.

To illustrate some of the special design requirements imposed by the nature of this service, and particularly by the fact that the equipment is usually in the hands of an operator with little or no technical knowledge or training, a description of the Hallicrafters Model HT-3 Marine Telephone unit is presented.

In this equipment the transmitter, receiver and power supply are all included in a single metal cabinet of the table-mounting type, 29¾ inches long, 11¾ wide and 19¼ deep. The ship's battery (or other supply source) and the antenna are the only "extras" needed for operation.

The receiver section consists of a 6-tube superhet which tunes the standard broadcast range in addition to the 1900-3100 range within which the operating frequencies for harbor service fall. The circuit is rather conventional and for that reason does not merit detailed discussion.

tries. It is particularly fitted for use in the automotive, aviation, communications, electrical instrument, marine radio, and other fields where flexible tubing plays an important part in wire insulation against heat, moisture, oils, etc. Irvington Varnish & Insulator Co., 24 Argyle Terrace, Irvington, N. J.

HYTRON HY75

The HY75 is a medium-power triode designed for efficient operation at frequencies from 50 to 300 megacycles. Short connec-

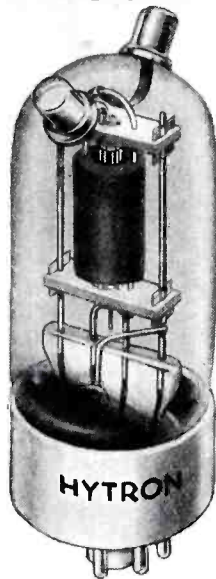

tion leads, small internal elements, low interelectrode capacitances are said to produce high plate circuit efficiency. The filament is of thoriated tungsten, wound in a spiral. A graphite anode and a pure tantalum vertical-bar grid are also used. This tube has characteristics so that it can be employed in u-h-f circuits of capacity-coupled stages. Hytron Corp., 76 Lafayette St., Salem, Mass.

CRYSTAL HOLDER SOCKET

A new socket for crystal-holders made

of transparent ultra-low-loss Amphenol "912" (pure polystyrene), which is non-hygroscopic, won't collect frost, and is tough and strong. Losses are said to be



negligible, and permit full crystal output to be applied to the grid of the oscillator tube. The mounting arrangement is interesting as it can be assembled either on top of a chassis, or from underneath, fastening with a single No. 6 screw. American Phenolic Corp., 1250 Van Buren St., Chicago, Ill.

PHONOGRAPH NEEDLE

Permo Products Corp., 6415 Ravenswood Ave., Chicago, have developed a special phonograph needle tipped with an alloy made from the rhodium, ruthenium and osmium group. The inherent characteristics of the alloy provide self-lubricating effect which reduces record wear, it is said. The needle is designed to give approximately 50-hours service on standard 10-in commercial shellac records.

ED. DENIKE ADVANCED

G. Ed De Nike, who has been advertising manager for National Union Radio Corp., Newark, N. J., for many years, has been appointed sales manager for New York State. His new headquarters are at 76 Monroe St., Geneva, N. Y.

Attention might, however, be called to the provision for "quiet a-v-c" and inter-carrier noise suppression; and to the fact that automatic gain control is applied to all tubes ahead of the second detector. This combination provides highly effective automatic regulation and in addition permits adjustment of threshold sensitivity to the level of existing noise, below which signals would not be useful for phone communication purposes anyway. If it is desirable to pull through a signal that is "way down in the noise" this control, located at the rear of the chassis can be advanced to provide the desired increased sensitivity.

This system is particularly useful when the receiver is left on, tuned to either the ship-to-ship or telephone exchange frequencies, awaiting possible incoming calls. With the manual threshold control adjusted properly there will be no sound from the loudspeaker until a carrier comes on.

The built-in loudspeaker is in the circuit of the receiver output except during actual telephone communication;

then removal of the hand-set from its hook cuts in the headphone and silences the loudspeaker.

Plate supply for the receiver is obtained from a vibrapak unit which is entirely independent of the transmitter plate supply generator.

The transmitter is designed for band-switch operation on three frequencies, and employs a 6F6 oscillator driving a pair of RK-39's in parallel. The latter are modulated by four 6L6's in push-pull parallel, operating directly out of single-button carbon microphone of the hand-set. Such is the power sensitivity of the 6L6's that ample drive is obtained when the microphone is spoken into at normal voice level.

The transmitter power supply is a 450-volt dynamotor of rugged construction. As the equipment is normally supplied, this unit is for operation from a 12-volt battery, as are also the receiver plate supply unit and the filament circuit arrangements. The HT-3 can, however, be supplied for operation from other d-c sources.

(Continued on page 30)

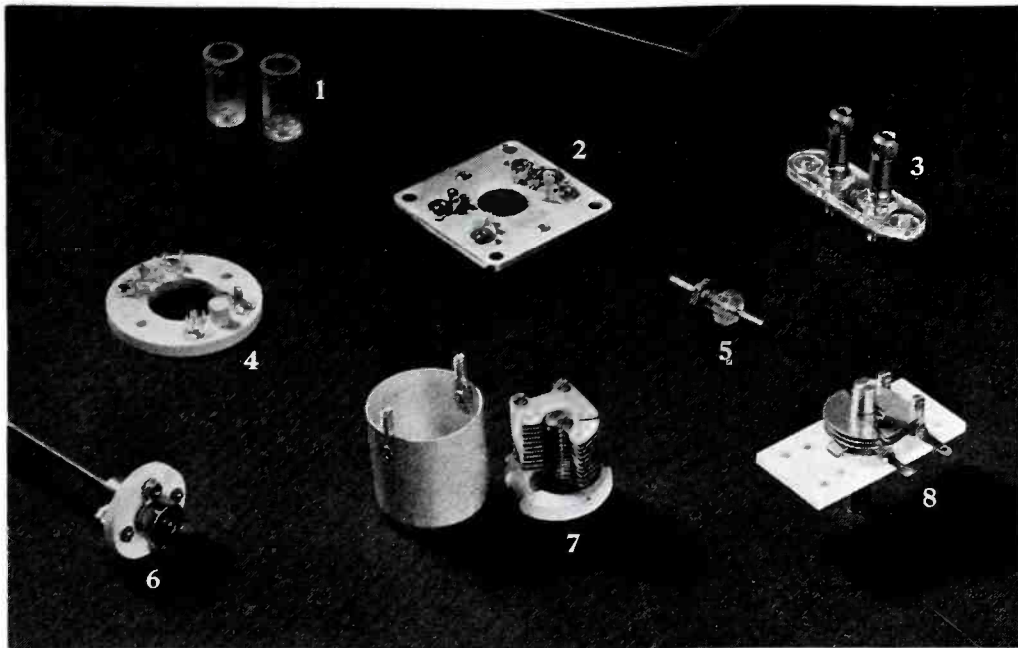

FOR HIGH FREQUENCIES

1. Small Coil Form
2. Pentode Acorn Socket
3. Victron Terminal Strip
4. Triode Acorn Socket
5. Victron Bushing
6. Flexible Coupling
7. Padding Condenser
8. Tuning Condenser

When constructing ultra-high frequency equipment, you will find that the parts shown above will simplify your problems. All were designed with the actual constructor's needs in mind by men thoroughly familiar with high frequency technique. Among them you will find an acorn socket with built-in by-pass condensers. You will find a flexible coupling that works around corners, so that you can lay out your circuit for electrical efficiency rather than mechanical necessity. You will find tuning condensers small enough to fit in compact layouts, and miniature coil forms to go with them. National makes what you need.

NATIONAL COMPANY  **MALDEN, MASS.**

MANUFACTURERS

More than 9000 engineers associated with the radio, television, broadcast, recording and two-way communications fields want to read about your new products in COMMUNICATIONS. Send complete data to "The Market Place" editor.



The combination of high tensile strength that assures a lasting bond, and faster, cleaner work made possible by quick-acting flux of pure water white rosin, has given Gardiner Rosin-Core Solder an outstanding reputation for efficiency and economy on radio work by expert or amateur. Yet, due to modern production methods and big sales, Gardiner Solders cost less than even ordinary kinds. Made in various alloys and core sizes . . . and in gauges as small as 1/32 of an inch . . . in 1, 5 and 20 lb. spools.



4819 S. CAMPBELL AVENUE

CHICAGO, ILL.

TAYLOR **VULCANIZED FIBRE**
PHENOL FIBRE
TAYLOR INSULATION
TAYLOR FIBRE CO., Norristown, Pa.

We manufacture a complete line of equipment
 Spot Welders, electric, from 1/4 to 500 KVA;
 Transformers, special and standard types; Incandescent Lamp Manufacturing Equipment; Radio Tubes, Ex-Ray, Cathode Ray, Photo Cells, Electronic Equipment Vacuum Pumps, etc. Tungsten Slugs, Rod and Wire Manufacturing Equipment; General Glass Working Machines and Burners; College Glass Working Units for students and laboratory; Photo-Flash Lamp Equipment; Neon Sign Manufacturing Equipment; Thermos Bottle Equipment; Wire Butt Welders; A.C. Arc Welders from 100 to 400 Amps. CHAS. EISLER, Pres.

EISLER ENGINEERING COMPANY

741 So. 13th St. (Near Avon Ave.)

Newark, New Jersey

YOU CAN'T AFFORD TO MISS
 THE
NATIONAL IRE CONVENTION
 HOTEL STATLER **BOSTON, MASS.**
 JUNE 27-28-29

PIEZO Electric Crystals Exclusively
 • Quality crystals for all practical frequencies supplied SINCE 1925. Prices quoted upon receipt of your specifications.
 Our Pledge: **QUALITY FIRST**
SCIENTIFIC RADIO SERVICE
 UNIVERSITY PARK **HYATTSVILLE, MD.**

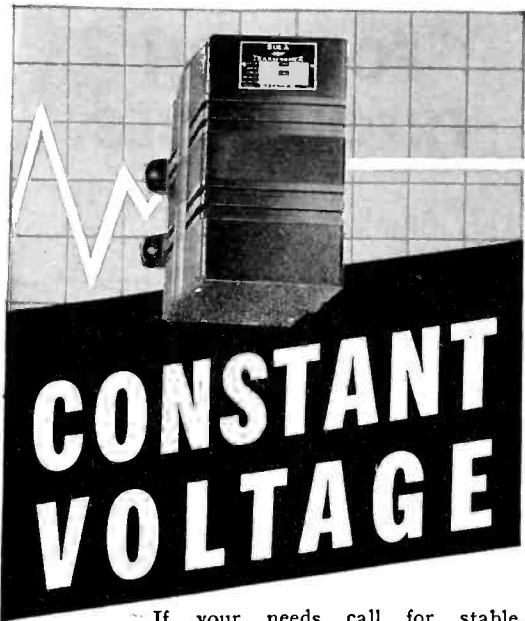

CONSTANT VOLTAGE

If your needs call for stable voltage at all times you can depend on SOLA CONSTANT VOLTAGE TRANSFORMERS to deliver for you, even though the incoming line voltage varies as much as thirty percent. Practical, economical, trouble-free—they can replace non-regulating transformers or perform as auxiliaries to equipment now in use.

WRITE FOR CATALOG ECV-22

SOLA

SOLA ELECTRIC CO. 2525 Clybourn Chicago, Illinois



RESISTANCE TUNED AUDIO OSCILLATORS

LOW DISTORTION—less than 1% for distortion measurements on high quality audio equipment and broadcast transmitters.

EXCELLENT STABILITY—saves time because NO ZERO SETTING necessary.

WIDE FREQUENCY RANGE—models available from 5 cps. to 200,000 cps.

HIGH OUTPUT—models available with 1 to 5 watts output

INEXPENSIVE—the Model 200B, 20-20,000 cps., 1 watt output—only \$85.80 net f.o.b. Palo Alto, California.

Write for complete information about these and other instruments

HEWLETT-PACKARD CO.
481 Page Mill Road • Palo Alto, California

MARINE RADIO

(Continued from page 28)

A "push-to-talk" button on the handset serves as the send-receive switch. When depressed, this actuates relays which start the dynamotor, apply plate voltage to all tubes in the transmitter, close the oscillator cathode circuit, open the receiver plate supply, switch the antenna to the transmitter and short out the headphones. All of this providing the transmitter filaments have been turned on. Releasing the button reverses the process.

Selection of the desired one of the three operating frequencies is accomplished by means of a band switch on the center front panel. This accomplishes all change-over operations. This is essential because no transmitter tuning of any kind can be done by a holder of a third grade ticket. The various adjustments, tuning, coupling, antenna loading, etc., must therefore be made by a properly licensed commercial operator when the installation is made. These are all made inside the cabinet; the coupling by means of clips on the coils, and the tuning by means of the lock-type, screw-driver adjustments accessible through the holes which may be seen in the tuning can in the top-view photo. Once pre-set they require no further attention unless some change is made in the antenna or transmitter, in which event the services of a duly qualified operator are again required to make the necessary readjustment.

Usually the equipment is adjusted on installation to provide for operation on (1) the marine telephone frequency for the area in which the boat is to operate; (2) the 2738-kc ship-to-ship frequency; and (3) the 2670-kc Coast Guard emergency stand-by channel. This gives the regular operator the choice of these three services by a flick of the switch.

Each shore telephone exchange station has its own assigned transmitting and receiving frequencies with receiving equipment always standing by on the

LAMINATIONS

for Output TRANSFORMERS of Highest Permeability

Standard stocks in a wide range of sizes for Audio, Choke, Output and Power Transformers. Write for dimension sheets.

M permanent MAGNETS

ALNICO (Cast or Sintered)

COBALT-CHROME-TUNGSTEN

Cast, formed or stamped permanent magnets for all purposes. Engineering cooperation backed by 38 years experience in magnet making.

TOOLS » DIES » STAMPINGS
HEAT TREATING

Thomas & Skinner
Steel Products Co.

1113 E. 23rd St. Indianapolis, Ind.

WHEN YOU CHANGE YOUR ADDRESS

Be sure to notify the Subscription Department of COMMUNICATIONS at 19 E. Forty-seventh St., New York City, giving the old as well as the new address, and do this at least four weeks in advance. The Post Office Department does not forward magazines unless you pay additional postage, and we cannot duplicate copies mailed to the old address. We ask your cooperation.

★

HOTEL CHELSEA

RIGHT ON THE BOARDWALK

FROM WITH MEALS & BATH \$6

ROOM ONLY & BATH \$3

Per Person 2 in a Room

FOR RECREATION OR RELAXATION

Choose the Chelsea

Here you will find everything to further your comfort and enjoyment—outside ocean-view rooms . . . wide verandas for lounging . . . sun deck . . . beautiful dining room at the ocean's edge . . . superb cuisine . . . varied sports and entertainment. You'll like your fellow guests, too, and the delightfully friendly atmosphere of the Chelsea.

SPECIAL WEEKLY RATES

ATLANTIC CITY

JOEL HILLMAN
J. CHRISTIAN MYERS
JULIAN A. HILLMAN

latter. Thus on the east coast the New York exchange transmits on 2590 and receives on 2198 kc; Boston transmits on 2506 and receives on 2110, etc.

The receiver section of the HT-3 can, of course, be operated alone, without the transmitter filaments turned on. It can thus be used to stand-by awaiting expected calls, or can be used to pick up broadcast entertainment.

The panel operating controls number seven in all. Of these, four are the conventional receiver controls: tuning, band-switch, off-on and volume. The transmitter controls are: off-on, band-switch and meter switch. These are in addition to the push-to-talk switch on the hand-set and the receiver threshold sensitivity control on the rear of the cabinet.

The meter switch permits the single meter to be used to check operation, the choice of positions being: r-f plates, r-f grids, modulator plates, transmitter filaments and receiver filaments. (In the 32-volt equipment rheostats provide for adjustment of filament voltages).

Current drain from a 12-volt source is $9\frac{1}{2}$ amperes for the entire receiver and the transmitter filaments; 35 amperes when the transmitter is on the air, pumping its normal 50 watts into the antenna.

A recommended quarter-wave antenna would be approximately 85 feet long overall, a length not possible on some smaller boats. In such cases compensation is provided by means of the loading coil in the transmitter and in extreme cases it may be necessary to use an additional load coil in series with the antenna lead.

Another type of equipment for marine radio telephone service, particularly for smaller boats or where the last word in operating simplicity is desired, is the HT-8 model of this same manufacturer illustrated in one of the accompanying photos. In this 25-watt output job both the transmitter and receiver circuits are pre-tuned internally to provide switch-selection choice of 5 transmitting frequencies and 6 receiving frequencies. The cabinet shown is for bulkhead or table mounting and contains only the receiver and transmitter, the power supply being separate for mounting in a locker or other out of the way place.

It is such equipment, plus the service developed and rendered by the telephone company, that has made the Jules Verne fantasy come true. The system is new but soundly established and there is every indication that it will within the next few years become as important to the small pleasure and commercial boat as its radio installation is to the great liner, whether considered from the standpoints of general communication or safety in emergencies.



CALLITE FORMED PARTS of TUNGSTEN . . . MOLYBDENUM for your specific applications

Makers of x-ray and high power transmission tubes can tell you about Callite service in formed parts. Never have specifications been more exacting. Callite's demonstrated ability to "meet every requirement" in this field is your guarantee of satisfaction when Callite is called in on your particular problem. Consult Callite today—take advantage of its modern laboratory facilities and over 20 years of research and experience. Write for Bulletin No. 30.

CALLITE TUNGSTEN CORPORATION
 542 39th ST. • UNION CITY, N. J. • Code Address "Callites"

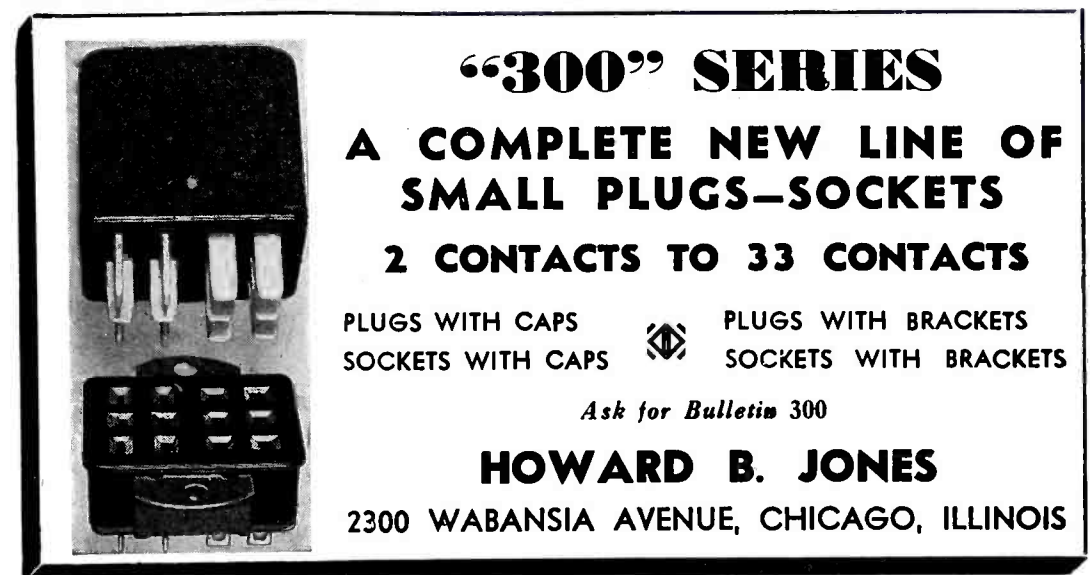

"300" SERIES
A COMPLETE NEW LINE OF SMALL PLUGS-SOCKETS
2 CONTACTS TO 33 CONTACTS

PLUGS WITH CAPS PLUGS WITH BRACKETS
 SOCKETS WITH CAPS SOCKETS WITH BRACKETS

Ask for Bulletin 300

HOWARD B. JONES
 2300 WABANSIA AVENUE, CHICAGO, ILLINOIS

STANDARD or SPECIAL . . .

WE FIT THEM TO YOUR JOB!

These specially-designed B&W Coils, used in conjunction with Cardwell Condensers, were adopted as standard in the 50 two-way transmitters engineered by Lieut. A. A. Kirchner, in consultation with Rissi Bros., Inc., for the Grand Rapids Police Department.

No matter what YOUR requirements—aircraft, marine, police, commercial, diathermy, general communications or amateur—chances are you can select the coil you need from the 125 standard B&W types. If not, we will gladly cooperate in designing the proper coil for your special requirements. Address B&W Engineering Dept. for full information and descriptive literature.

B & W AIR INDUCTORS
 BARKER & WILLIAMSON • ARDMORE, PA.



WAXES AND COMPOUNDS FOR INSULATION and WATERPROOFING of ELECTRICAL and RADIO COMPONENTS

● such as transformers, coils, power packs, pot heads, sockets, wiring devices, wet and dry batteries, etc. Also WAX SATURATORS for braided wire and tape and WAXES for radio parts. The facilities of our laboratories are at your disposal to help solve your problems.

Zophar MILLS, Inc.
FOUNDED 1846
120-26th ST., BROOKLYN, N. Y.

PINCOR



A
SIZE
FOR
ANY
JOB

DYNAMOTORS

Pincor Dynamotors are as much "at home" on tough jobs as on ordinary ones. No wonder they are specified by governmental and commercial users universally for air craft, marine and broadcast service, police units, sound systems, auto radios, etc. Available in a wide variety of types and frames for any requirement. Highest efficiency and regulation. Capacities: 5 to 850 watts. Input, 6 to 110 volts; output, up to 1750 volts.

Specify "Pincor"—and be sure of thousands of hours of dependable, quiet service. Mail coupon for complete information.

PIONEER GEN-E-MOTOR CORP.
CHICAGO, ILL.

Export Address: 25 Warren St., N. Y., N. Y.
Cable: Simontrice, New York

Pioneer Gen-E-Motor Corporation
Dept. R-5E.
466 West Superior St., Chicago, Ill.
Please send information on Pincor Dynamotors, Motor Generators and special power supply units.

Name

Address

City..... State.....

Index to Advertisers

	Page
A	
Aerovox Corp.	21
American Lava Corp.	15
Amperex Electronic Products, Inc., Inside Front Cover, 1	
B	
Barker & Williamson.....	31
Bliley Electric Co.....	27
Brush Development Co., The.....	Back Cover
C	
Callite Products Division.....	31
D	
Daven Co., The.....	23
Driver Co., Wilbur B.....	20
DuMont Labs., Allen B.....	25
E	
Eisler Engineering Co.....	29
F	
Fairchild Aviation Corp.....	20
G	
Gardiner Metal Co.....	29
General Electric Co.....	3
General Radio Co.....	Inside Back Cover
H	
Hallcrafters, Inc., The.....	27
Hewlett-Packard Co.....	30
I	
Ideal Commutator Dresser Co.....	20
J	
Johnson Co., E. F.....	22
Jones, Howard B.....	31
L	
Lenz Electric Mfg. Co.....	4
Lingo & Son Inc., John E.....	18
N	
National Co., The.....	29
O	
Onan & Sons, D. W.....	27
P	
Pioneer Genemotor Corp.....	32
Presto Recording Corp.....	19
S	
Scientific Radio Service.....	29
Sola Electric Co.....	30
T	
Taylor Fibre Co.....	29
Thomas & Skinner Steel Products Co.....	30
U	
United Transformer Corp.....	17
Z	
Zophar Mills, Inc.....	32

PLAN TO ATTEND

the
**NATIONAL
IRE CONVENTION**

JUNE 27-28-29

Hotel Statler Boston

A GRACIOUS HOST
FROM COAST TO COAST



The Gotham



The Drake

The Blackstone



The Town House



Bellevue Biltmore

A. S. KIRKEBY, Managing Director

**KIRKEBY
HOTELS**

NEW SQUARE-WAVE GENERATOR

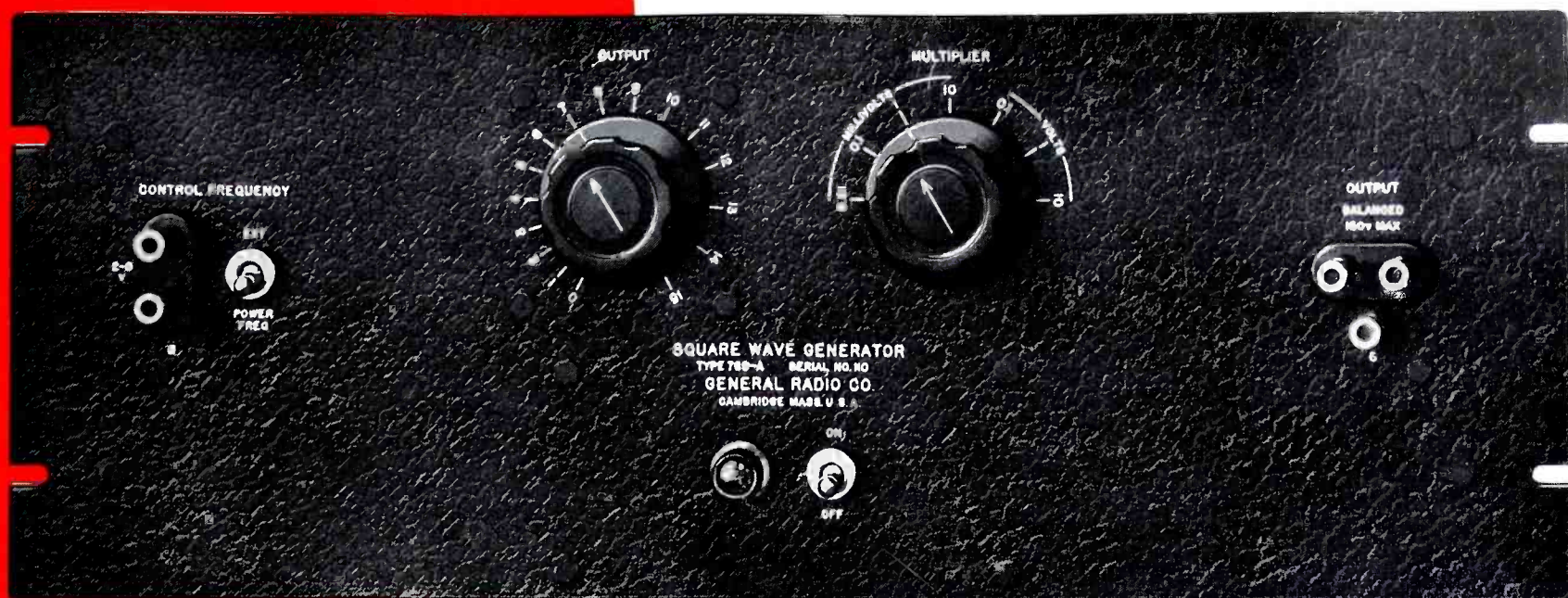

SPECIFICATIONS

FREQUENCY RANGE

Square waves with fundamentals from 10 cycles to 5,000 cycles per second can be produced. The output circuit passes frequencies between 0.1 cycle and 250,000 cycles.

OUTPUT VOLTAGE

Continuously variable — peak-to-peak, 150 volts with balanced output; 75 volts, unbalanced. Minimum output voltage 10 microvolts.

ATTENUATOR

Slide wire and 6-step multiplier are used. The wave shape is not affected by the attenuator.

SQUARENESS OF WAVEFORM

At low frequencies, entire rise in voltage takes place in 0.001 cycle.

OUTPUT IMPEDANCE

500 ohms, balanced; 250 ohms, unbalanced. The impedance is independent of frequency down to d-c.

EXTERNAL OSCILLATOR

An oscillator capable of delivering 6 volts, open circuit, is required to excite the generator. A 60-cycle control system is built in.

for Audio-Frequency Testing

GENERAL RADIO announces the new Type 769-A Square-Wave Generator, primarily designed for audio-frequency testing. In its essentials the circuit consists of an amplifier arranged to overload with great ease. A voltage of from 2 to 8 volts, obtained from the power line or an external source, is amplified to about 75 volts and then has both sides of the wave cut off by a double diode. This squared signal is re-amplified and clipped again by a pair of cascaded diodes. The signal is then amplified and attenuated to any desired level.

It is now generally recognized that the entire behavior of an amplifier or other circuit to applied signals is completely determined by a knowledge of its response to sinusoidal signals in phase and amplitude over the frequency scale. Similarly its performance is completely determined from its transient response to an abrupt steep wave front—a square wave.

The square-wave generator method of testing audio systems offers the simplest and most direct method for observing the effects of both phase shift and amplitude response in a single test. Square-wave generators are very valuable in a-f testing of the over-all response of television systems, amplitude or frequency-modulated systems, receivers, amplifiers or any of the audio-frequency components of any of these.

● WRITE FOR BULLETIN 591

Type 769-A Square-Wave Generator...\$225.00

GENERAL RADIO COMPANY

CAMBRIDGE, MASSACHUSETTS

Branches in New York and Los Angeles

A New Frontier

IN THE SOUND FIELD

• *FINE RECORDING* of professional quality in the home, in educational institutions, and countless professional applications presents the same **CHALLENGE** and **OPPORTUNITY FOR THE FUTURE** that the phonograph and radio have in the past.

• Record libraries made directly in the home or school from the outstanding musical broadcasts, records of history-making speeches in these history-making times, of children's voices and of home music . . . objective study and progress records in speech correction, language, drama, singing and instrumental training, and for the professional artist and public speaker.

• *FINE QUALITY RECORDING* opens these and countless other opportunities . . . made possible with the new Brush crystal record cutter and low mass permanent stylus pickups, companion elements to produce a **NEW HIGH STANDARD** of quality with virtually any of the hard or soft recording materials.



Technical bulletins on theory, methods, and equipment gladly furnished on request.

THE BRUSH DEVELOPMENT CO.

3311 PERKINS AVENUE

CLEVELAND, OHIO