

COMMUNICATIONS

i n c l u d i n g
TELEVISION
ENGINEERING

JULY
1939

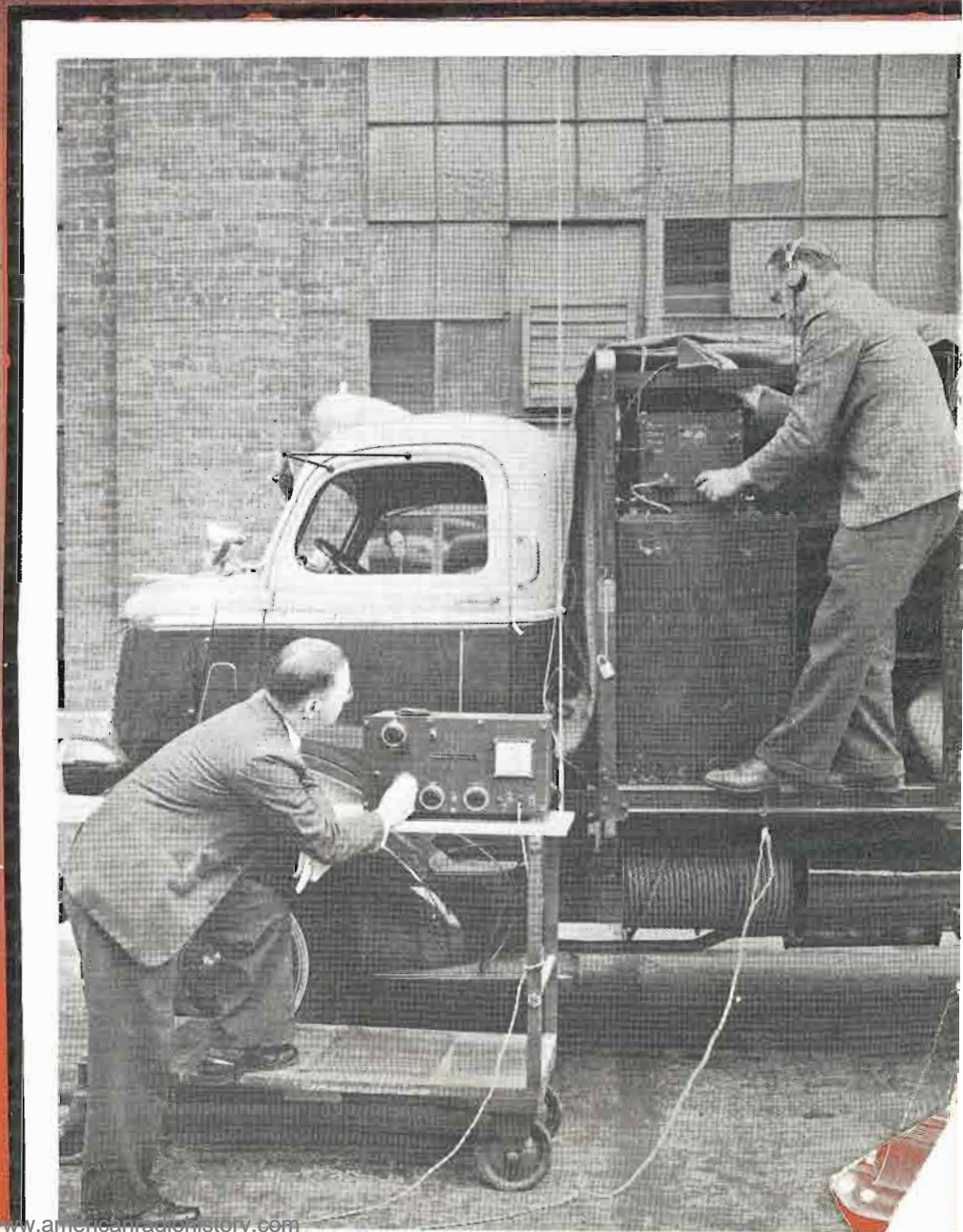

KVGB

Technical Department
GREAT BEND, KANSAS

LEO LEGLEITER
Chief Engineer
DAVE WILSON
Production Manager
JUSTIN BRADSHAW
Traffic Manager
VERN MINOR
Business Manager

May 16, 1939

Gentlemen:-

...Going back over the transmitter logs of KVGB, I find that two 872's and two 838's were installed in the transmitter on March 4th, 1937. These tubes have never been removed from their respective sockets, except, of course, for the routine prong and socket polishing jobs, and the periodic emission tests.

These four Amperex tubes have seen every day, every hour of broadcasting from this station, and are, according to the last tests, in "as good as new" condition.

Two Amperex 203A's were placed in service at the same time, but were removed after successfully and satisfactorily passing 6,094 hours. Two other tubes of a well known make were then installed. The last of these competitive tubes gassed out of service at the end of 2,586 hours. The Original Amperex tubes were then restored to service and at the last accounting had 7,571 hours of interrupted service behind them.

The initial tube installation of 872's and 838's are, as I stated above, still in service, and have passed 10,157 hours of perfect performance. Some of these hours, by the way, were hard ones, in which line voltage fluctuations, and extremely high powerline peaks would raise the filament voltage to the eleven and twelve volt levels. Thought you might like to know.

With this perfect record to serve as a basis of comparison, it's not hard to guess the name our replacement tubes will carry.

Yours enthusiastically,

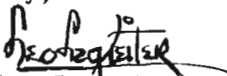
Leo Legleiter,
Chief Engineer, KVGB

Thank You KVGB

AMPEREX ELECTRONIC PRODUCTS, Inc.
79 Washington Street **Brooklyn, New York**

Export Division: 100 Varick Street, New York, U. S. A. Cables: "ARLAB"

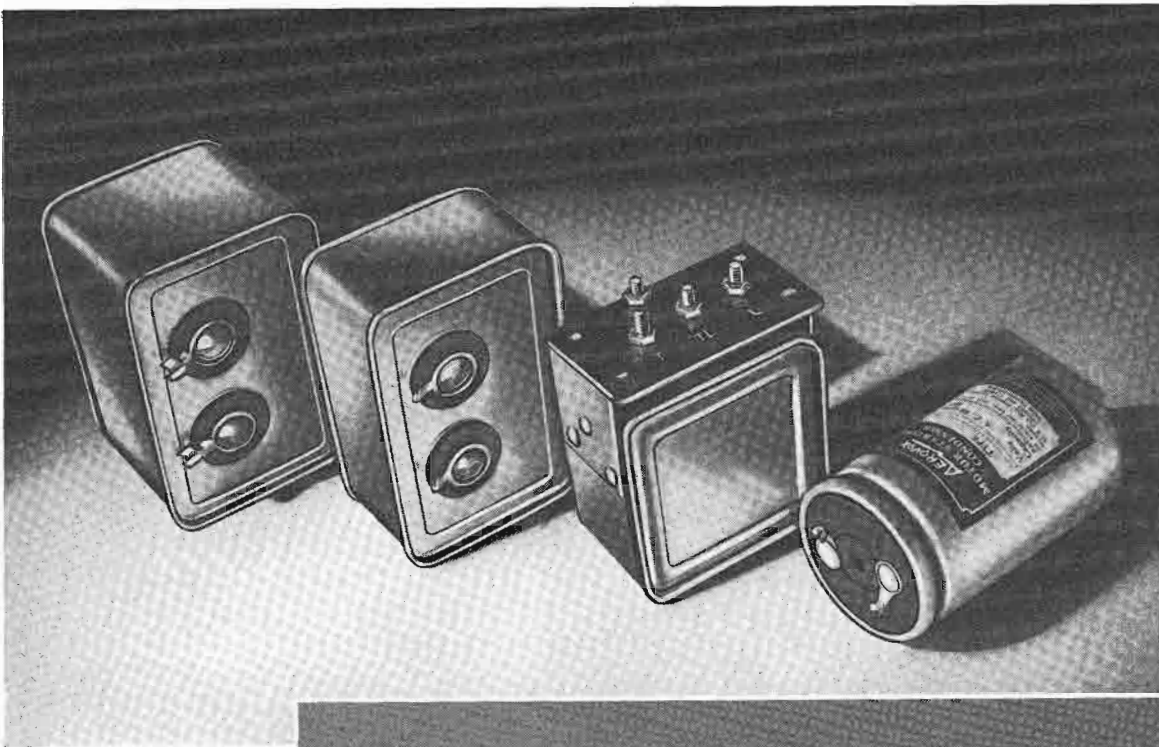

*Not RADIO, yet of
real interest to RADIOMEN*



● AEROVOX motor-starting capacitors of the electrolytic and the oil-filled paper types may mean little or nothing to you, as such. But . . .

The fact that AEROVOX pioneered in the development of the high-capacity electrolytic capacitors for motor-starting functions, and has produced the greater part of the couple of millions of such units now used in electric refrigerators, has

implications of extreme interest to you.

This simply goes to prove that AEROVOX is a pioneering organization. AEROVOX has the needed research and engineering facilities to solve difficult condenser-application problems. And the fruits of the laboratory can be multiplied indefinitely by the new AEROVOX plant, to meet the scope of any field.

Submit Your Condenser Problems . . .

● Our engineers will gladly collaborate with you in working out the best combination of condensers, other components and circuits. This is our A.A.E. (Aerovox Application Engineering) service which is saving manufacturers untold sums of money in lowered first cost and in minimized comebacks.

AEROVOX CORPORATION
New Bedford, Mass.
 Sales Offices in All Principal Cities



RAY D. RETTENMEYER

Editor

• Editorial Comment •

THIS year's annual convention of the Institute of Radio Engineers will again be held in New York City, September 20-23, at the Hotel Pennsylvania. From all indications the 1939 Radio Engineering Show will be bigger and better. Registration last year was 1,768, a gain of about 50% over 1937. Attendance at the 1939 show should be even higher. More complete details will be published in a later issue of COMMUNICATIONS.

THE Federal Communications Commission has increased the normal license period for standard broadcast stations from six months to one year . . . a move which affects all of the 735 standard broadcast stations now operating in the United States and territorial possessions.

The Commission's action follows a proposal made early this year by the FCC's Committee on proposed rules and regulations. By extending the license period, we believe the Commission has taken a step in the right direction since it will save a great deal of time and trouble for both the broadcasters and the Commission.

MEMBERS of the Associated Police Communication Officers will hold their annual convention at the Hotel President, Kansas City, Missouri, October 2-5. Lt. Roy DeShaffon of the Kansas City Police Department Communications Division is preparing a program of business and entertainment which seems to promise one of the best conventions in APCO history.

The organization is composed of police communication supervisors, operators, and others actively engaged in the field. We understand that the manufacturers are cooperating wholeheartedly in convention arrangements and that they will provide some interesting demonstrations and displays. Watch for further details in COMMUNICATIONS.

• Contents •

COVER ILLUSTRATION

Engineers testing radio equipment in one of the supply trucks of the Thaw Trans-Asiatic expedition. The four mobile units in the expedition should be able to maintain contact over distances up to 200 miles. This 14,000-mile tour will start in Paris and end in Bombay, India. Photo courtesy General Electric Co.

- 5 IMPEDANCE MEASUREMENTS ON BROADCAST ANTENNAS, Part II By Donald B. Sinclair
- 10 THE POLYRHETOR By G. T. Stanton
- 12 SOUND EFFECTS CONSOLE By W. W. Strathy
- 15 THE N.A.B. CONVENTION
- 17 TELEVISION FUNDAMENTALS—Part IV: The Cathode-Ray Tube as a Television Reproducer By F. Alton Everest
- 20 TELEVISION ECONOMICS—Part VI By Dr. Alfred N. Goldsmith
- 23 SOUND MOTION PICTURE FILMS IN TELEVISION—Part III By John A. Maurer
- 31 BOOK REVIEWS
- 32 VETERAN WIRELESS OPERATORS ASSOCIATION NEWS
- 36 THE MARKET PLACE
- 40 INDEX OF ADVERTISERS

Copyright 1939, Bryan Davis Publishing Co., Inc.

BRYAN S. DAVIS
President

JAMES A. WALKER
Secretary

Published Monthly by the
BRYAN DAVIS PUBLISHING CO., Inc.

19 East 47th Street
New York City

New York Telephone: PLaza 3-0483

SANFORD R. COWAN
Manager

PAUL S. WEIL
Advertising Manager

A. GOEBEL
Circulation Manager

Chicago Office—608 S. Dearborn Street

Telephone: Wabash 1903



Wellington, New Zealand—Te Aro Book Depot
Melbourne, Australia—McGill's Agency

Entered as second class matter October 1, 1937, at the Post Office at New York, N. Y., under the act of March 3, 1879. Yearly subscription rate: \$2.00 in the United States and Canada, \$3.00 in foreign countries. Single copies: twenty-five cents in United States and Canada, thirty-five cents in foreign countries.

NEW HEAVY DUTY RADIATION-AIR COOLED TUBES

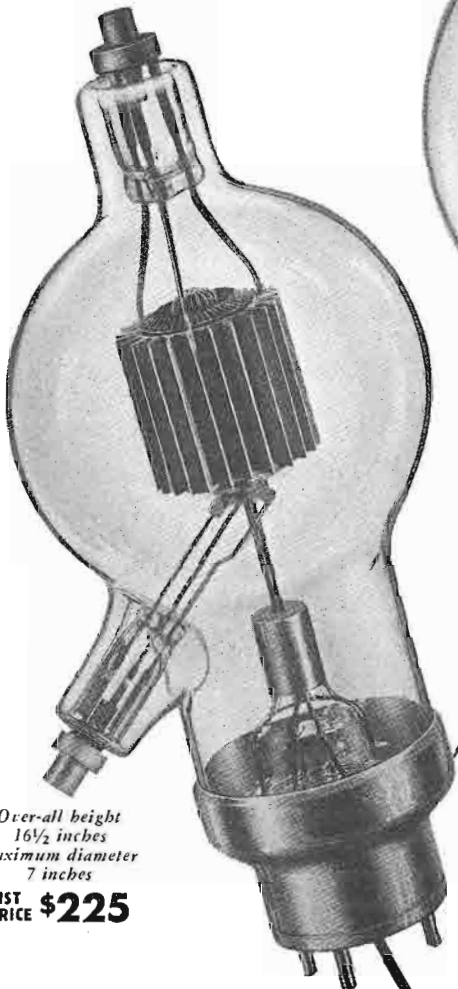

Over-all height
16½ inches
Maximum diameter
7 inches
LIST PRICE \$225

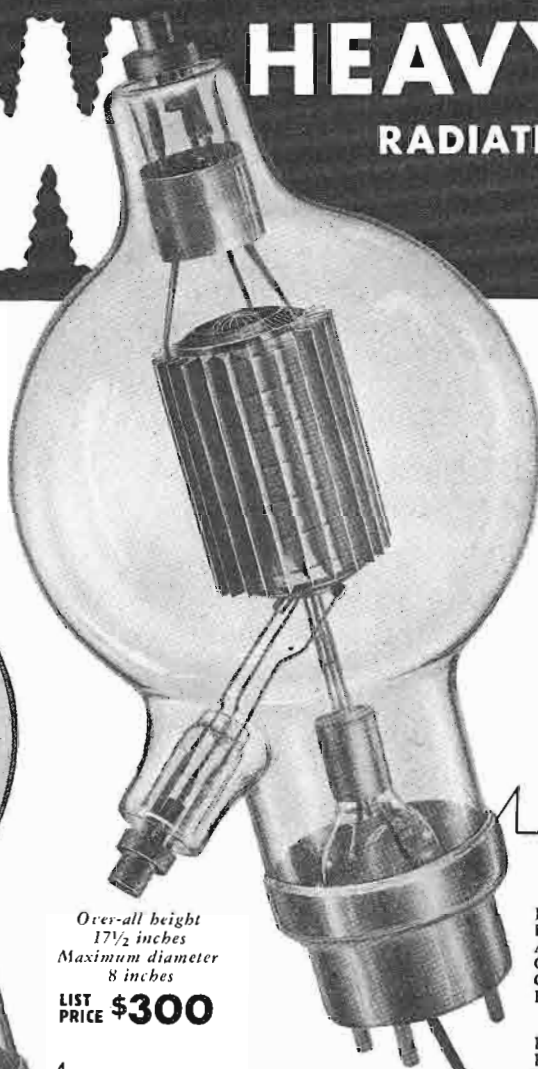

Over-all height
17½ inches
Maximum diameter
8 inches
LIST PRICE \$300

2000T

Filament voltage	10 volts
Filament current	26 amps
Amplification factor	18.5
Grid-plate capacity	9 mmfds
Grid-filament capacity	13 mmfds
Filament-plate capacity	1 mmfds

MAXIMUM RATINGS

Plate voltage	6000 volts
Plate current	1.75 amps
D. C. Grid current	.2 amps
Plate dissipation	2000 watts

1500T

Filament voltage	7.5 volts
Filament current	26 amps
Amplification factor	18.5
Grid-plate capacity	7 mmfds
Grid-filament capacity	10 mmfds
Filament-plate capacity	.9 mmfds

MAXIMUM RATINGS

Plate voltage	6000 volts
Plate current	1.25 amps
D. C. Grid current	.175 amps
Plate dissipation	1500 watts

**10 TO 15 KW ANTENNA
POWER WITH PUSH-
PULL RADIATION-AIR
COOLED TRIODES.**

**Eimac
TUBES**

Eitel-McCullough, Inc., 768 San Mateo St., San Bruno, Cal.

Here's new economy and greater efficiency for communications companies and broadcasters. Eimac 1500T and 2000T open new fields for the design of commercial transmitters. These new tubes were designed especially for medium high power radio and television transmitters. The unconditional guarantee against failures resulting from gas released internally—the "Eimac-processed" tantalum elements—the extra rugged grid and filament and downright ability to outperform most other vacuum tubes makes them the most outstanding vacuum tube on the market today. Low interelectrode capacities and high electrical efficiency place them "head-and-shoulder" above the old, expensive to operate, water-cooled tube of medium power which is fast disappearing. Immediate recognition by the world's leading radio engineers places the stamp of approval on the new Eimac 1500T and 2000T. Technicians, station owners, manufacturers are invited to write for complete data—you should have this information.

RADIO WOULD HAVE SAVED OVER 2,000 LIVES!

The Battle of New Orleans would never have been fought had radio communications been developed in 1815. Andrew Jackson met and defeated the British at New Orleans two weeks after peace had been signed at Ghent, Belgium... Today via R.C.A. Communications, Inc., news travels at lightning speed. This radio message service of the Radio Corporation of America provides instant communication to and from 43 countries and among leading cities of the United States.

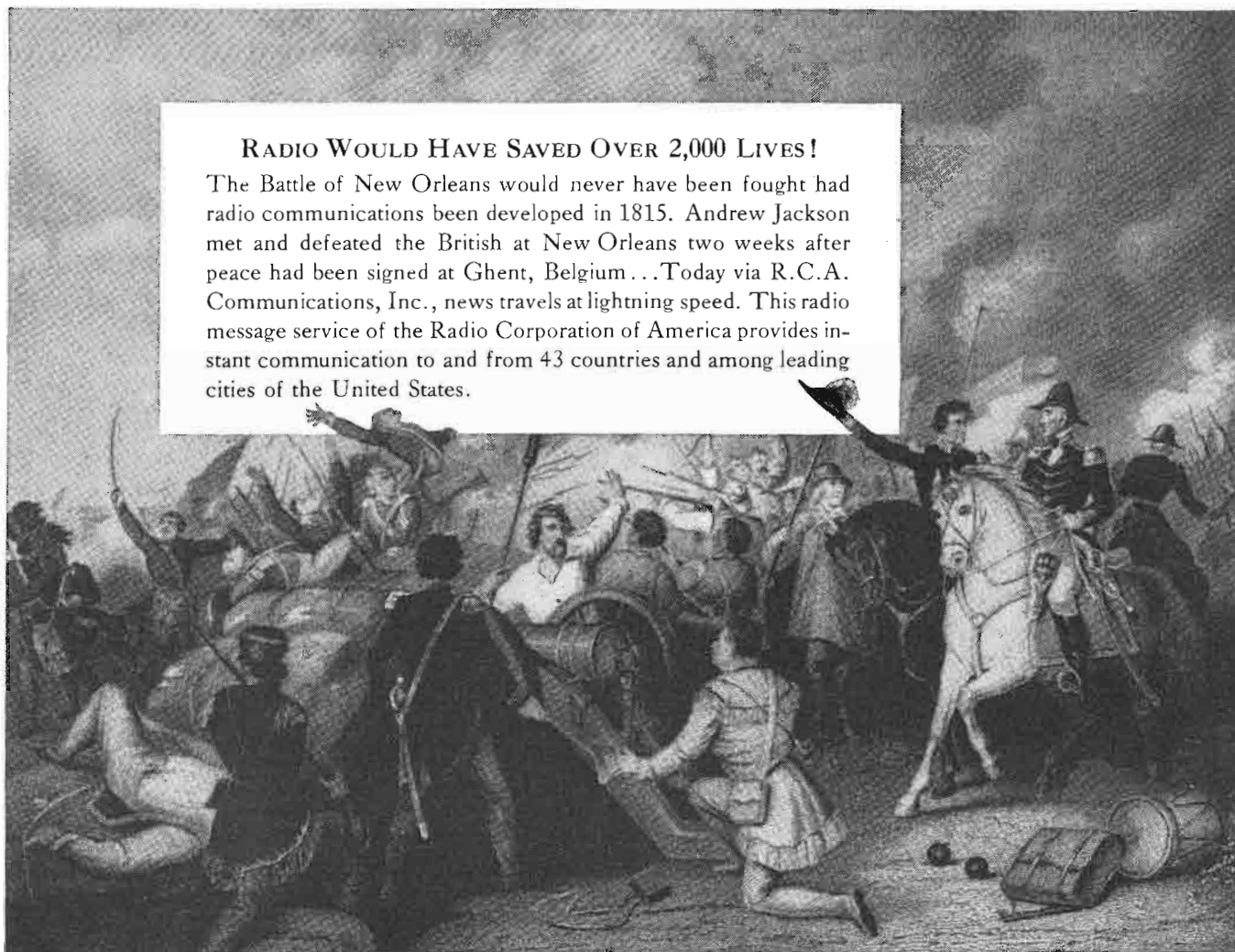

RCA Helps Make Radio a Welcome Guest in 27,500,000 Homes

IN RETURN for its welcome in the American home, radio provides millions of dollars worth of entertainment, education, and news which listeners receive free. In addition, radio renders services to the government, churches, universities, farms, ships, airplanes, and business which have an untold value.

How vital these services are is dramatically illustrated in contrasting pre-radio days with the present. For example... just imagine the cost and confusion that would be caused if news of the signing of a peace treaty should take two weeks to travel now from Europe to America as it did in 1815!

RCA's Role in Increasing the Services of Radio!

Research in RCA Laboratories is the basis of the

ever expanding services of the Radio Corporation of America. Research made possible the development of NBC and its two networks, the Red and the Blue. Research creates the extra values offered in RCA Victor Radios, RCA Victor Television Receivers, RCA Victrolas, Victor and Bluebird Records, and all of the sound, radio, and motion picture equipment built by RCA Victor.

All of the activities of RCA are dramatized in the RCA exhibits at the New York World's Fair and at the San Francisco Exposition. We cordially invite you to visit these fascinating exhibits.

Trademarks "RCA Victor," "Victrola" and "Victor" Reg. U.S. Pat. Off. by RCA Mfg. Co., Inc.

Listen to the "Magic Key of RCA" every Monday, 8:30 to 9:30 P. M., E. D. S. T., on NBC Blue Network.



RADIO CORPORATION OF AMERICA RADIO CITY, N. Y.

RCA Manufacturing Co., Inc.
Radiomarine Corporation of America

R.C.A. Communications, Inc.
National Broadcasting Company

RCA Laboratories
RCA Institutes, Inc.

IMPEDANCE MEASUREMENTS ...

By

Donald B. Sinclair

General Radio Company

On Broadcast Antennas

IV. METHODS OF IMPEDANCE MEASUREMENT SPECIFICALLY ADAPTED TO ANTENNA MEASUREMENTS

Factors Affecting Choice of Method

General

THE methods of impedance measurement discussed so far have been considered purely from the general standpoint, with no especial emphasis placed upon the nature of the impedance to be measured, the convenience and speed of the measurements, or the equipment necessary. Some of the factors affecting the choice of a specific method are discussed in the following paragraphs.

Nature of Impedance to be Measured

Analyses of methods for impedance measurement, in their elementary forms, are customarily based upon the assumption that the device to be measured is a two-terminal element. This is, of course, strictly untrue because any physical circuit element has residual capacitance to ground and mutual inductance and capacitance to nearby circuits and objects, in addition to the nominal impedance between the terminals. In physically small circuit elements, such as coils and condensers, the residual parameters are often negligible and, in the majority of cases, through judicious use of electromagnetic shielding, they can be localized in such a way that they are rendered innocuous.

Antennas and transmission lines, in contrast, cannot be considered as two-terminal devices except when one side is grounded, because of the relatively large distributed ground capacitances which exist. In practice, one side of the impedance to be measured usually is grounded, and the measuring circuit must be designed to suit this condition.

The magnitudes of the impedances to be measured in radiating systems range all the way from a few ohms to several thousand. Since the choice of a method of measurement depends upon the spe-

Part II

cific ranges of resistive and reactive components and upon the accuracy required at different impedance levels, it is important to break down such an indefinite impedance range and examine it critically. To do so, it is helpful to list the general types of impedances that it may be necessary to measure. These are: (1) Antennas: (a) self impedances, (b) mutual impedances; (2) Transmission Lines: (a) characteristic impedance, (b) terminated impedance; (3) Matching and Phasing Networks: (a) characteristic impedance, (b) terminated impedance; (4) Circuit Elements.

Antenna self-impedances range from less than 20 ohms for antenna lengths less than about 0.2λ to as much as 1,500 ohms at about 0.4λ . Most broadcast antennas, however, fall into the relatively low-impedance category, say less than 100 ohms. In measurements of antenna impedance proper, the resistive component must be determined with a high degree of accuracy because it is used directly in the determination of input power. Antenna mutual impedances can range from essentially zero to values of the same order of magnitude

as the self-impedances. The impedance of a properly terminated line is essentially resistive and equal to the characteristic impedance. For concentric lines, the characteristic impedance is practically always less than 100 ohms.

The characteristic impedances of matching and phasing networks can be found from open- and short-circuit measurements, as can those of transmission lines. The orders of magnitude, however, are somewhat different when artificial $\lambda/4$ sections are used. Sections of this type can have very low open-circuit impedances and very high short-circuit impedances, both of which are essentially resistive. Terminated impedances, of course, are of the same order of magnitude as the line characteristic impedances.

The circuit elements that have to be measured in connection with radiating systems are the coils and condensers that are used in the various coupling units. They have impedances that are highly reactive and that range from a few ohms to a few hundred ohms.

The general characteristics of the measuring circuit can now be reduced. It must, first, measure impedances with one side grounded; it must, second, measure resistance components accurately up to, say, 100 ohms at least and preferably higher; and it must, third, measure reactive components over a more or less indefinite range.

Both series-resonance and bridge methods satisfy these requirements fairly well and are recommended in the 1938 Standards of Good Engineering Practice concerning Standard Broadcast Stations issued by the Federal

Communications Commission and in the 1938 Standards on Transmitters and Antennas issued by the Institute of Radio Engineers.

Extension of Range

Series-resonance and bridge methods can be used directly to measure resistive

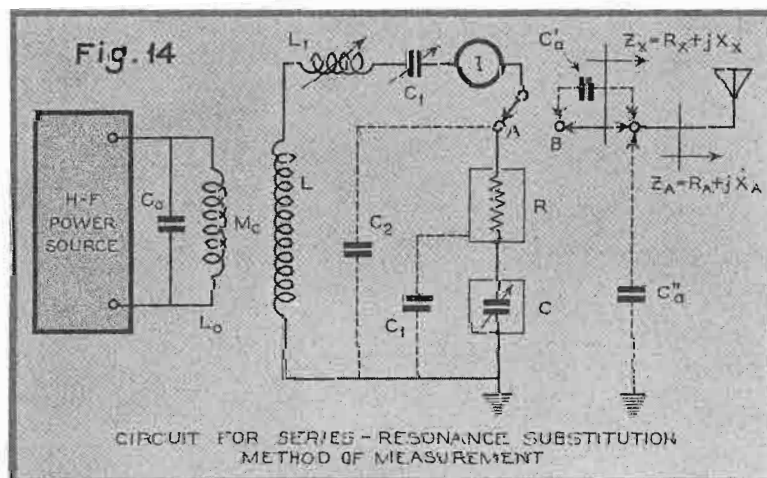

CIRCUIT FOR SERIES-RESONANCE SUBSTITUTION METHOD OF MEASUREMENT

as the self-impedances.

The characteristic impedance of a transmission line is often found from measurements of the input impedance with the far end open- and short-circuited. The impedances to be measured are ordinarily highly reactive, both inductive and capacitive, and their mag-

components up to about 100 ohms and reactive components that fall within the range of the standard condenser used. For higher values of resistance and reactance, either a different method must be used, or the range must be extended.

The range can be extended quite easily by the use of known series or parallel condensers. The technique, in effect, is to change the impedance of the unknown so that it falls within the range of the method of measurement. Two simple examples can be cited which will illustrate the nature of the extension of range by means of external fixed condensers.

(1) An impedance of $60 + j70$ ohms is to be measured at 1,000 kilocycles with an r-f bridge that has a range of 0-111 ohms resistance and 138-3980 ohms capacitive reactance (40-1150 mmfd). The resistive component of the unknown is within the range of the bridge; the reactive component is not. If, however, a 200-mmfd condenser, which has a reactance of about $-j800$ ohms at 1 mc, is connected in series with the unknown, the bridge must measure an impedance of $60 - j740$ ohms, which is well within its rating both for resistance and reactance.

(2) An impedance of $250 - j130$ ohms is to be measured at 1 mc with the same bridge. Both resistive and reactive components are out of the range of the bridge. If, however, a 500-

components of the unknown within the range of the bridge with a single parallel condenser. When this condition occurs, a large enough condenser should first be shunted across the unknown to bring the resistive component within the range of the bridge, and the reactance should then be brought within the range of the bridge by a series condenser.

Series-Resonance Substitution Method

The circuits that are used for measuring impedances take many different forms, depending upon conditions, and they may differ materially in appearance from the simple basic circuits discussed so far. A typical substitution circuit, for instance, is shown in Fig. 14. It can be taken as representative of the series-resonance methods in common use.

The high-frequency power source shown should be of about 50 watts power, but not more than 10% of the available power should be dissipated in the antenna in order to comply with the 1938 Standards of Good Engineering Practice concerning Standard Broadcast Stations issued by the Federal Communications Commission. The milliammeter, I, should have a full-scale reading of about 100 ma. The decade resistor, R, should have steps at least as small as 1 ohm and should preferably be of the inductance-compensated type. The condenser, C, should be of the pre-

and standard resistance, R, to restore the proper value of I.

When the resistance, R, and the capacitance, C, are properly set, the lead can be moved from point A to point B without changing either the tuning or the current read by the meter, I. The resistance then equals the resistive component of the antenna impedance, and the condenser reactance equals the reactive component of the antenna impedance. If the reactive component of the antenna impedance is inductive, or if it is capacitive but outside the range of the standard condenser, C, the auxiliary condenser, C'_a , should be connected in series, between points B and B'. Proper choice of the value of C'_a , will bring the reactive component within the range of the standard condenser. If the resistive component of the antenna impedance is higher than the maximum resistance of the decade resistor, R, the auxiliary condenser C''_a should be connected in parallel between point B' and ground. Proper choice of the value of C''_a will bring the resistive component within the range of the decade resistor. If the reactive component is then outside the range of the standard condenser, C, the addition of a series condenser, C'_a , of the proper magnitude is necessary.

The errors that occur in this set-up are principally caused by residual capacitances. The two capacitances denoted by C_1 and C_2 , in particular, can cause error and should be kept as small as is practical. C_1 can be measured by removing the resistance, R, from circuit, connecting the movable wire directly to the standard condenser, C, and tuning to resonance, then inserting the resistance, R, in circuit, connecting the movable lead to point A, and noting the change in C necessary to restore resonance. It should be added directly to the capacitance of C when determining the reactive component. C_2 is ordinarily small when a shielded decade resistor is connected as shown, and causes no serious error. To avoid error, the capacitance to ground of the movable lead must be kept as nearly the same as possible when moved from point A to point B.

Small errors can also occur in the standards used because of residual parameters and skin effect. The standard condenser, C, has a resistive component, which in a typical case, can range from about 0.02 ohm at a setting of 1,000 mmfd and a frequency of 1500 kc to about 1 ohm at 100 mmfd and 550 kc. The compensated resistor has an inductive reactance, which commonly ranges from about 3.5 ohms at 550 kc to 10 ohms at 1500 kc. It also has skin effect, which causes the zero resistance to reach approximately 0.65

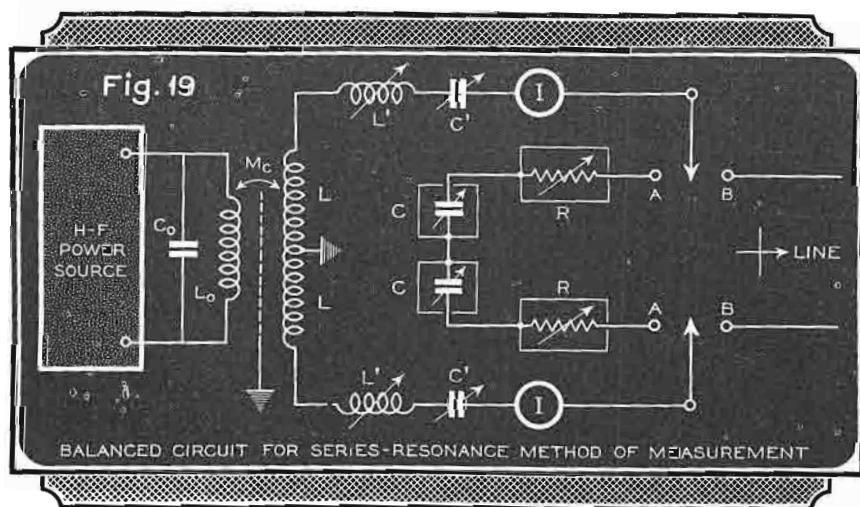

mmfd condenser is connected in parallel with the unknown, the bridge must measure an impedance

$$Z = \frac{(250 - j130) (-j320)}{250 - j450} =$$

$97 - j146$ ohms, which is within the range for both reactive and resistive components.

When high impedances are being measured, sometimes it is not possible to bring both the resistive and reactive

precision type, with a maximum capacitance of the order of 1000 mmfd.

The procedure for measuring an antenna with this circuit is as follows:

(1) Connect lead to point B, and adjust coupling, M_c , until a reading somewhere between half- and full-scale is obtained with the circuit tuned to resonance by means of L' and C' .

(2) Disconnect lead from point B, and connect to point A. Adjust standard condenser, C, to restore resonance

ohms.² A large part of the shunting capacitance across the series resistor can be avoided by connecting the resistor between the compensated decade resistor, R_x , and the standard condenser, C_x . Although terminals are not provided on the panel, it is recommended that this connection be made internally if the series-resistance method is to be used and accurate reactance measurements are required at high resistance levels.

The bridge can also be modified for the measurement of high resistive components by connecting the standard condenser, C_x , and the compensated decade resistor, R_x in parallel. With this combination, the bridge can be used to measure high impedances in terms of their parallel components as follows:

(1) Connect a 100-ohm resistor and a 500-mmfd fixed condenser in parallel, connect the combination to the *unknown* terminals of the bridge, and balance the bridge with the standard condenser, C_x , and resistor, R_x , connected in parallel. Call the settings C_1 and R_1 , respectively.

(2) Connect the unknown impedance across the parallel resistor-condenser combination in the *unknown* arm and rebalance with C_x and R_x . Call the settings C_2 and R_2 .

The change in the admittance of the standard arm must equal the change in

tance components, is easily obtained from the well-known relations

$$R_x = \frac{G_x}{G_x^2 + B_x^2} \dots\dots\dots(7)$$

$$X_x = \frac{-B_x}{G_x^2 + B_x^2} \dots\dots\dots(8)$$

Two sources of error occur in the parallel method of measurement that are not found in the series method. Because of the residual inductance, L_x , the conductance of the compensated decade resistor is not exactly equal to $1/R$ as implied by equation (5), and the change of susceptance as the setting is varied is not zero as implied by equation (6).

For frequencies below 1500 kc and resistance settings above 30 ohms, the error in conductance is less than 1%. The change of susceptance in going from a setting of 100 ohms to a setting of 30 ohms, however, is about 10,000 μ mho at 1500 kc, and large errors are likely to occur at broadcast frequencies unless corrections are applied. The compensating inductance, L_p , also introduces an error. The error, however, is ordinarily so small as to be negligible. It can be avoided by using a true parallel substitution method in which the unknown impedance is connected across the standard condenser, C_x , and resistor, R_x , instead of across the parallel combination connected to the *unknown* terminals. In this case the initial resistance balance should be made at a setting of less than 100 ohms, since the final balance, with the

unknown connected in parallel, will occur at a higher setting.

An additional error sometimes arises when a modulated signal is used to drive the bridge because the bridge cannot be balanced simultaneously at the carrier frequency and at the sideband frequencies. The amount by which the bridge is unbalanced at the sideband frequencies when it is balanced at the carrier frequency is determined by the relative rates at which the impedances of the two lower bridge arms change with respect to frequency. The amount of unbalance is negligibly small, for instance, when measuring a condenser, but it may be considerable when measuring a coil or an antenna. When it exists, the two first-order side bands beat together in the radio receiver used as a null detector and produce a signal of twice the modulating frequency. The observed effect is, therefore, the occurrence of a second harmonic at the fundamental balance point. This second harmonic is of no particular importance except as it may become so strong as to obscure the fundamental balance. Its presence, however, is an indication that an error can occur. The error is caused by second-order sidebands, which arise either from second harmonics in the modulating voltage or from non-linearity of the modulation characteristic. When the carrier is balanced out by the bridge, the second-order side bands beat with the first-order side bands in the radio receiver to produce a fundamental tone. Since, in order to obtain a fundamental null, the bridge must be unbalanced so as to produce a component of fundamental that is equal and opposite to the spurious signal, an erroneous reading necessarily occurs. Adjusting the radio-receiver tuning changes the relative phase of the side-bands and carrier even when the tuning is nearly optimum, and, in addition, changes the relative amplitudes when the tuning is near the edge of the channel. The phase and magnitude of the spurious signal, and consequently the bridge balance, therefore change with the receiver tuning. When a strong second harmonic at balance occurs, a change of the tuning of the receiver will indicate when error is occurring by causing a shift in the bridge balance. The error can be avoided completely by using an unmodulated signal and a receiver which will produce a heterodyne note. The receiver used should be provided with a good sensitivity control, and it should be possible to cut out the automatic volume control. Strong signals, particularly when applied to receivers having a heterodyne oscillator coupled to the i-f stages, cause an AVC effect, which masks the approach to bridge balance. Auto-

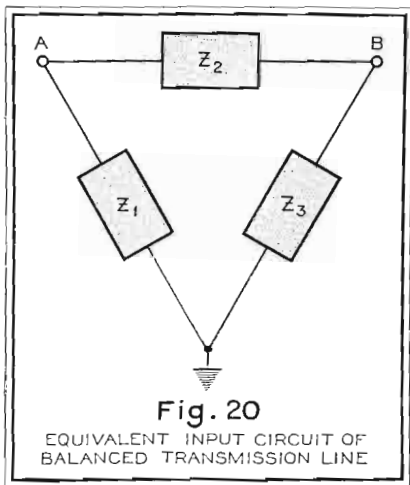

admittance of the unknown arm, which is, in turn, equal to the unknown admittance, $Y_x = G_x + jB_x$.

$$G_x = \frac{1}{R_2} - \frac{1}{R_1} = \frac{R_1 - R_2}{R_1 R_2} \dots\dots\dots(5)$$

$$B_x = \omega (C_2 - C_1) \dots\dots\dots(6)$$

The unknown impedance, expressed in terms of series resistance and reac-

²The shunting reactance is approximately 1600 ohms at 1500 kc. In the worst case, therefore, the resistance error for a 150-ohm series resistor would be 0.85%. The corresponding reactance component would be 13.7 ohms capacitive. At 550 kc the same resistance error and reactance component occur for a series resistance of about 400 ohms.

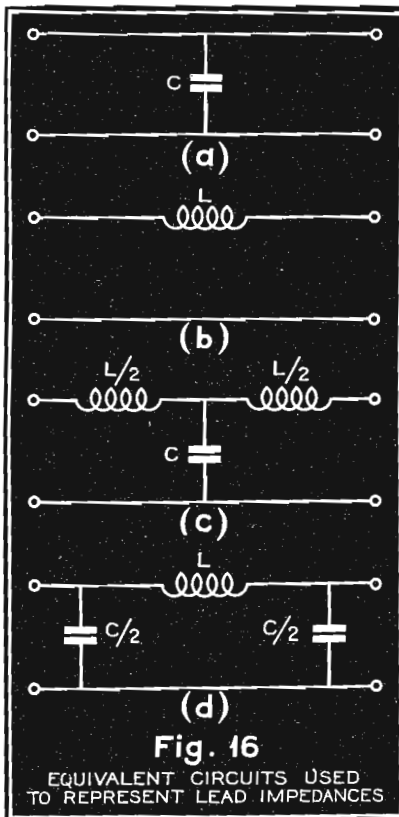

matic volume control, of course, tends to keep the signal level constant and to make the balance point extremely difficult to find.

V. CORRECTION ERRORS

Inductance and Capacitance of Leads

In addition to the errors which are inherent in the particular method used, there are errors that are common to all methods. These occur mainly because of the residual inductance and capacitance of the wiring that is used to connect units together and to connect the unknown impedance to the measuring equipment.

So long as the wires are very short compared with the wavelength, it is unnecessary to consider them as transmission lines and to analyze their effects with complicated formulas. They can be represented, instead, by one of the simple equivalent circuits shown in Fig. 16.

None of the circuits of Fig. 16 is a rigorous equivalent but each can be used for corrections in certain special applications. When the terminating impedance is very high, the lead inductance is often negligible, and the circuit of Fig. 16(a) is adequate; when the terminating impedance is very low, the lead capacitance is often negligible and the circuit of Fig. 16(b) is adequate. For impedances that are neither very low nor very high it is sometimes necessary to use one of the more complicated circuits shown in Fig. 16(c) and 16(d). It should be emphasized that even these circuits can be considered equivalent only at frequencies so low that $\omega^2 LC \ll 1$.

When connecting an antenna to a measuring circuit it is often difficult to avoid the use of long leads because of the mechanical layout of the antenna tuning unit. In many cases, however, the effects of these leads can be minimized by including the leads in the measuring circuit. In the ordinary bridge set-up illustrated in Fig. 15, for instance, if the auxiliary series condenser, C'_a , is placed at the antenna end of a long lead from the bridge, the initial balance with C'_a shorted to ground at point A eliminates the effect of the inductance of the lead, and it may be unnecessary to make any further correction. This point should be checked, however, since the capacitance may be important. The capacitance of the lead can be measured by plugging a condenser of convenient size into the *unknown* terminals of the bridge to obtain an initial balance and then noting the change in the standard capacitance, C_s , required to rebalance the bridge when the lead is connected and disconnected. One side of the auxiliary series condenser, C'_a , should be connected to

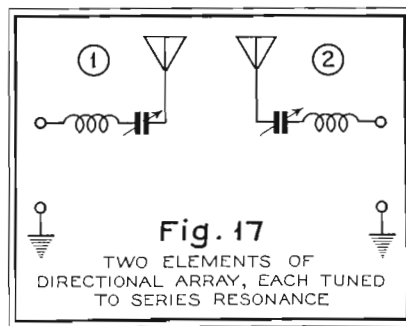

the antenna end of the lead when making this measurement so that the capacitance to ground of C'_a is included. The inductance of the lead can be determined by connecting a condenser of convenient size in series at the *unknown* terminals of the bridge and taking the difference between the measured impedances when it is grounded at the bridge and when it is grounded through the lead at point A. When the parallel connection of the bridge is used, if the lead is left connected to the bridge at all times and is connected and disconnected from the antenna at the far end, the effect of the lead capacitance is eliminated. A check should be made, however, to insure that the lead inductance does not cause error.

Since bridge methods are based upon voltage nulls, they are more susceptible to pickup than series-resonance methods, which are based upon current maxima. The generator, bridge and detector should therefore be individually shielded and should be connected together with shielded leads. A single ground connection should be made at the bridge and carried through to the detector and generator by the shields of the coaxial leads in order to avoid spurious currents in the shields and consequent pickup. Particularly for use in antenna measurements the receiver should be well protected from direct pickup by shielding and from pickup on the power leads by filtering.

Because bridges operate at a null they are also susceptible to interference and atmospheric noise picked up by the antenna. Under severe conditions the accuracy of balance can be greatly reduced by interference from these unwanted signals. The simplest way to minimize the trouble is to increase the ratio of desired to undesired signal by increasing the power input to the bridge. If increasing the power input up to the maximum rating for the bridge resistors does not create sufficient improvement, better results can sometimes be obtained by substituting a communications-type receiver, with crystal filter and noise suppressor, for the standard type of broadcast receiver normally used.

VI. SPECIFIC MEASUREMENT TECHNIQUE

Simple Antennas

When the impedance of a simple antenna is measured, it is important to determine it at the point at which the antenna meter is connected. This is particularly true, of course, of the resistive components from which the an-

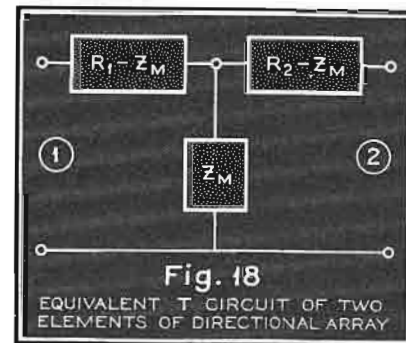

tenna power is computed. When the antenna impedance is low, any lead corrections which occur are almost always caused by inductance and apply only to the reactive component of the measured value. When the antenna impedance is high, however, the lead corrections are largely caused by capacitance and apply to both the resistive and the reactive components of the measured value.

In order to avoid error, it is wise to use a number of different lead lengths and, if possible, a number of different methods of measurement to determine the unknown impedance. For example, when measuring a high-impedance antenna with the bridge, three different methods can be used, namely:

(1) *Series connection. Range extended with series resistor in standard arm.*

(2) *Series connection. Range extended with auxiliary parallel condenser in unknown arm.*

(3) *Parallel connection.*

These three methods, in turn, can be used with minor variations. When the consistency obtained among the measurements is of the order of the desired accuracy, it is safe to assume that the major errors have been eliminated.

Multi-Element Arrays

The interpretation of measurements on arrays is complicated by the existence of mutual impedances. When the elements other than the one being measured are deliberately detuned, their effect on the impedance of the element to be measured is a minimum, and the measured value can be taken as the self-impedance. Conversely, if one of the other elements is tuned to resonate at the measuring frequency, its effect on the element to be measured is a maxi-

(Continued on page 26)

THE POLYRHETOR

By G. T. STANTON

ELECTRICAL RESEARCH PRODUCTS, INC.

AN interesting and unique sound system has been installed at the General Motor's exhibit—"Highways and Horizons"—at the New York World's Fair. Known as the Polyrhettor, it serves as a guide for the visitors attending the exhibits, describing the miniature highways of tomorrow to those seated in the endless "Carry-around."

Essentially the mechanism consists of a finely wrought steel drum twelve feet in height mounted on a circular base and supported by seven equally spaced columns. This drum carries twenty-four bands of sound film which are pierced at 150 equally spaced points by needles of light. As the drum revolves, these light beams shine through the sound track and actuate photoelectric cells, similar to the method used in sound motion pictures. The voice currents generated by the light sensitive cells are amplified and pass through a system of trolleys to sound projectors

in each pair of moving cars. The same machine also controls the speed of the

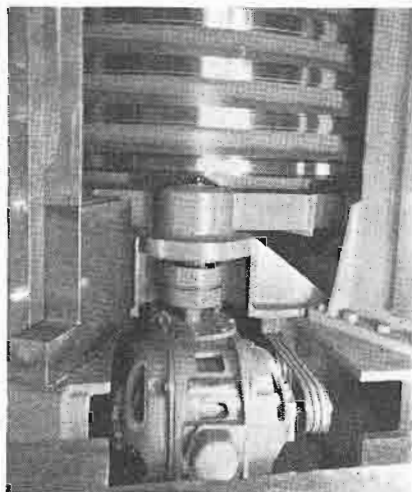

Driving force is secured from a synchronous motor acting through a speed-reduction unit.

Schematic diagram of Polyrhettor.

cars so that the "guide" always speaks at the correct moment.

The trolley system is also unique. It was found that a satisfactory relationship between sound and scene could be maintained for each spectator if a separate voice circuit was supplied to each pair of cars. This would appear to mean 150 different circuits and trolley tracks. But space between the car rails would not admit more than a few of them. The solution was trolley sectionalization. Seven trolley rails, instead of 150, were laid down and these were broken, with insulating joints, into seventy-foot sections throughout the whole tour.

The story for the first seventy-foot section of the tour is recorded on one of the twenty-four loops of film. This record takes forty seconds to play; one complete revolution of the loop; the time required for a given car to travel seventy feet. One of the light-beams, which scans this loop, is asso-

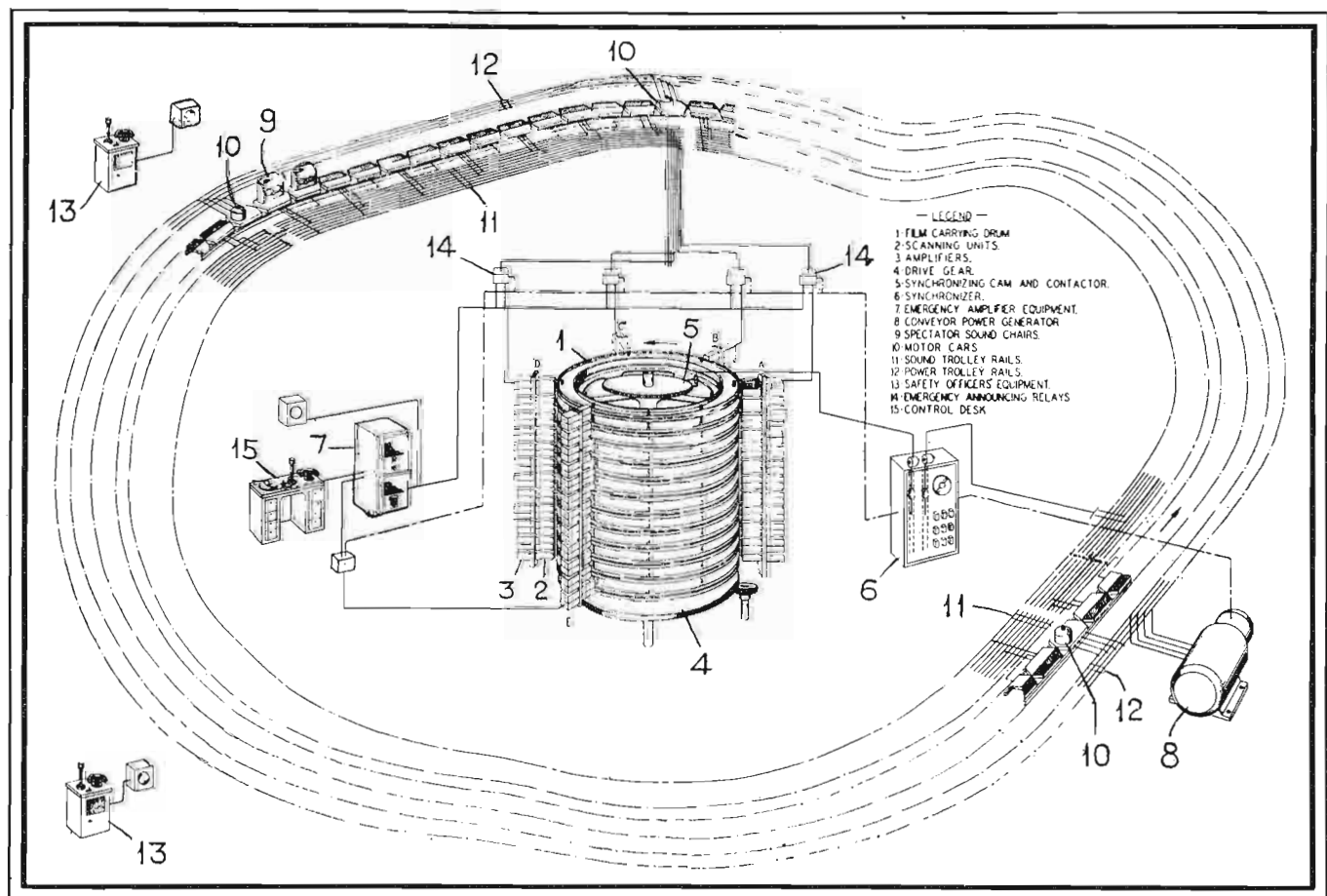

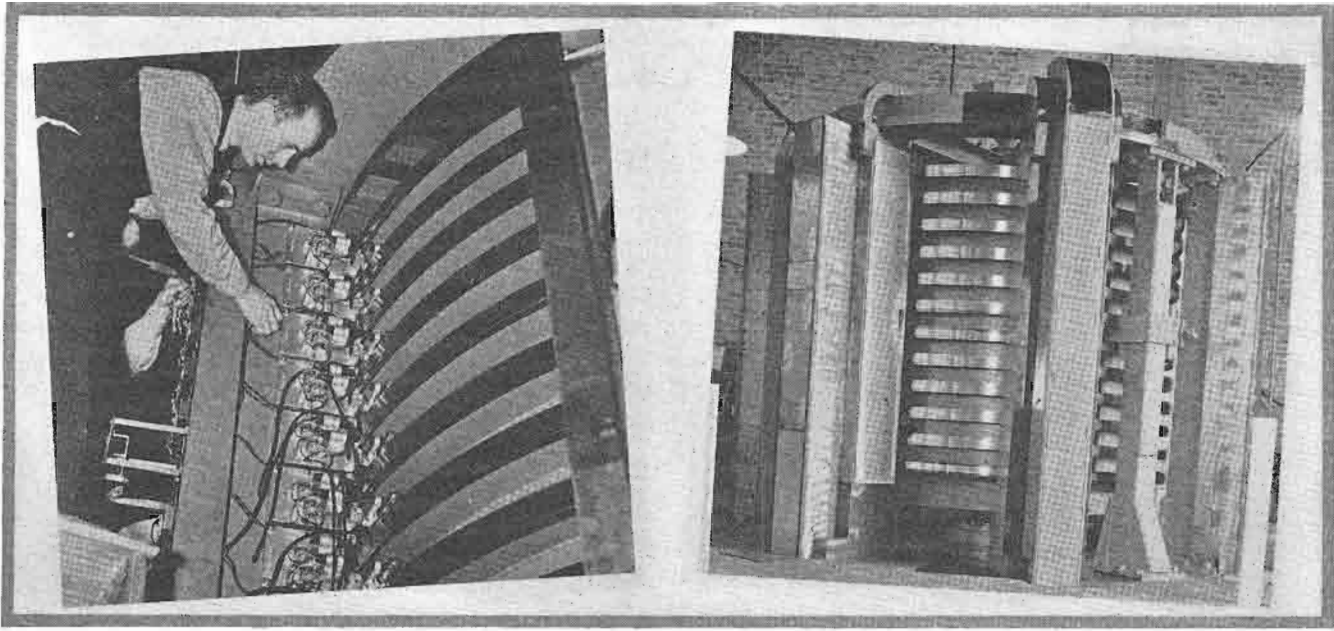

Left: Adjusting one of the 150 optical scanners. Right: A view of the Polyhetor showing mounting method.

ciated with one of the seven trolley rails extending along the first seventy-foot section of panorama. The loudspeakers in the first pair of cars on each seventy-foot section connect with this particular rail. Sliding contact is made through a silver impregnated shoe beneath the car.

When the rotation of the drum is properly synchronized with the speed of the cars, this shoe first touches its trolley just as the story is commencing. As the story finishes, for that seventy-foot section, the contactor shoe is carried to the next section of the same rail where the story is continued on a second loop of film. Similarly, all the remaining sections of trolley, fed from other film loops, tell consecutive chapters of the story until the cars have completed one round trip.

In addition to this first scanner, six others are spaced at equal intervals around the loop of film, as previously mentioned. Each of these scanners connects with some one of the six remaining trolley rails in each section of track. All twenty-four loops are so scanned by seven beams. Obviously,

the beginning of the story recorded on each loop arrives at each scanner progressively. By connecting each pair of cars, in any one section of the seven rail track, with the proper trolley rail, sound matching the scene before that pair of cars will be projected to the visitor.

An eighth trolley rail, paralleling these seven, provides a common return path for all speech circuits. In addition, a short section of rail slotted into approximately two-foot lengths extends along the loading and unloading zone for synchronizing purposes. This ninth rail will be discussed later.

Synchronization between the rotating drum and the conveyor—at first might appear to present difficulties, but it

Left: Examining one of the 24 bands of 16mm motion picture film. Right: Showing the "Carry-go-round" in which the speakers are mounted.

proved to be a straight-forward process accomplished by apparatus adapted from automatic elevator control. An interrupter-cam, driven by the rotating drum, actuates a make-and-break contact, thereby advancing a mechanical contactor or "selector" in step with the drum's rotation. A second contactor, mounted on one car in each conveyor section, makes and breaks contact with a special synchronizing rail, which is located in one of the sections between the loading and unloading platform. This circuit advances a second "selector," step-by-step with the car's progress. At each step these two selectors connect with relays so arranged that a premature arrival of the car "selector" functions to slow the conveyor; a tardy arrival to speed it up. The relays produce a temporary speed correction only, and a motor-driven rheostat establishes a semi-permanent speed correction at a slow rate. This double arrangement avoids "hunting."

In event the conveyor only is stopped, the sound machine continues to rotate and picks up the conveyor at a syn-

(Continued on page 29)

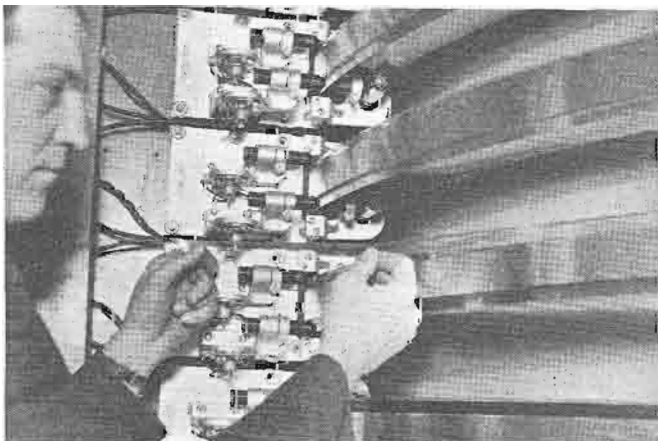

SOUND EFFECTS CONSOLE

By **W. W. STRATHY**

Sound Engineer

WHOLESALE RADIO SERVICE CO.

IN these days of lavish expenditures on radio broadcast productions the job done by the W. P. A. radio unit in New York City with Vernon Radcliffe as production manager is worthy of notice. Started early in 1937, this organization has put on over twenty-five-hundred broadcasts. This is something of a record in itself but is even more impressive when it is realized that every one of these broadcasts is built up in all details within the organization. Research, scripts, talent, direction, production; these are all a part of the activity.

The presentations represent the most intensive program of adult education ever undertaken by a single group; not alone in the great volume of programs, but in their diversity. The primary object is the rehabilitation of the underprivileged through educational entertainment; giving listeners and particularly the foreign elements, a keen insight into American institutions.

The very fact that the entire program is educational in nature makes the job just that much more difficult but so cleverly are the presentations handled, and so skillfully dramatized, that they are acceptable to sixteen radio stations in the New York metropolitan area.

With unlimited finances this would

be considered a real accomplishment. But in this instance stark economy is necessary throughout. There can be no highly paid talent, no "name" bands, no world-famous authors. As with other W. P. A. activities, such money as is available must be devoted almost exclusively to salaries, providing jobs for those who need them. And it might be added that through understanding and sympathetic direction excellent talent has been developed which has found its way back into private industry.

That is the general story of the W. P. A. broadcast activities in New York City. At present there are ten weekly productions running and two more about to be added. Each is a part of a series and some of the serials have been running for more than a year. Each serial has a definite objective. Several are concerned with citizenship, others with history, music, popular law and science. Some are carried over national and regional hook-ups, others over individual stations, depending largely on their nature. There is no outlay for station time.

From a technical standpoint, the variety of stations employed complicates the picture considerably. With all programs dramatized, sound effects naturally play an important role. It was

found, however, that the equipment afforded by the smaller stations was inadequate. A complete sound department was therefore organized and sound effects constructed within this organization to insure a uniform high standard of quality in all programs. Turntables for the playing of sound recordings were likewise designed within the organization and were built to W. P. A. specifications by Wholesale Radio Service, Inc. Because of its relatively low cost, its flexibility and the advantage which similar equipment offers to broadcast stations and program production organizations, this Lafayette sound effects console is described in detail.

The block diagram of Fig. 1 shows the general circuit arrangement and the photographs illustrate physical layout.

The entire unit is mounted in a sturdy telephone-black cabinet approximately five feet in length, with rubber tired castors and push-bars on the ends for ready mobility (Fig. 2). Metal trim is chromium plated except the control panel which is gray crackle. All controls except those involved in "spotting" are mounted on the sloping control panel and each is clearly labelled.

Provision is made for operation from either a-c or d-c to meet requirements for universal use in New York City where both types of current are supplied. While the same line plug is used, regardless of the type of supply, the equipment automatically adapts itself through a relay switching arrangement (Fig. 5) developed by Lafayette engineers. The converter is built-in and the operating characteristics of the entire equipment remain identical on either type of supply.

Four input circuits are provided, three for the self-contained record pickups and one for microphone input. Following is a 4-channel mixer-fader system with key switches which permits any one or more to be cut in on either of the two main amplifier channels.

Fig. 4 shows the arrangement of amplifier equipment. It is all mounted on a swinging rack where it is instantly accessible. Fig. 3 shows this rack in normal position. By removing the two panels shown in this view the under-

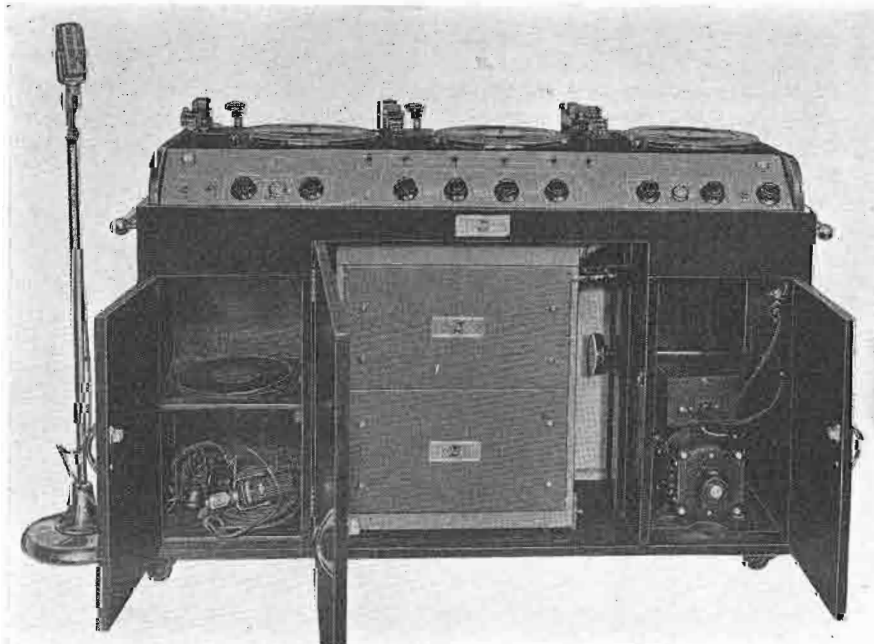

Fig. 2. Front view of console with doors open showing equipment.

Fig. 4. Another view of the console. Note accessibility of amplifier.

chassis assemblies of the amplifiers are exposed should servicing be necessary.

With reference to Fig. 4, the 2-stage microphone amplifier is shown in the upper right-hand corner of the amplifier rack and to the left of it the preamplifiers which feed the two main amplifiers. These main amplifiers are shown directly below and at the bottom is the dual power supply, one section of which provides the plate supply for the power output stages and the other the plate supply for all other tubes as well as the fixed grid-bias voltage for the power stages.

The entire rear half of the console serves as the loudspeaker enclosure, within which two 12-inch speakers are mounted with appropriate grills in the rear wall of the console. The light colored partition at the rear of the amplifier compartment (Fig. 4) serves as a ventilation as well as acoustic baffle. Behind this, at the bottom of the loudspeaker enclosure, an exhaust fan is mounted. Air is drawn in through the ports in the bottom of the amplifier compartment, circulates around the amplifiers, over the top of this baffle, around the turntable motors and down through the loudspeakers. Thus complete ventilation of the entire equipment is effectively maintained.

Two of the three turntables are of the constant-speed 78-33-1/3 rpm type while in the case of the third the speed is completely variable by means of a speed-control knob at the extreme right end of the control panel. Many unusual sound effects are obtained by varying the record speed, while other effects are more simply obtained in this manner than by the more common means.

Precise "spotting" is accomplished by means of a new development by Lafayette engineers in which the ordinary dial method is employed to select the

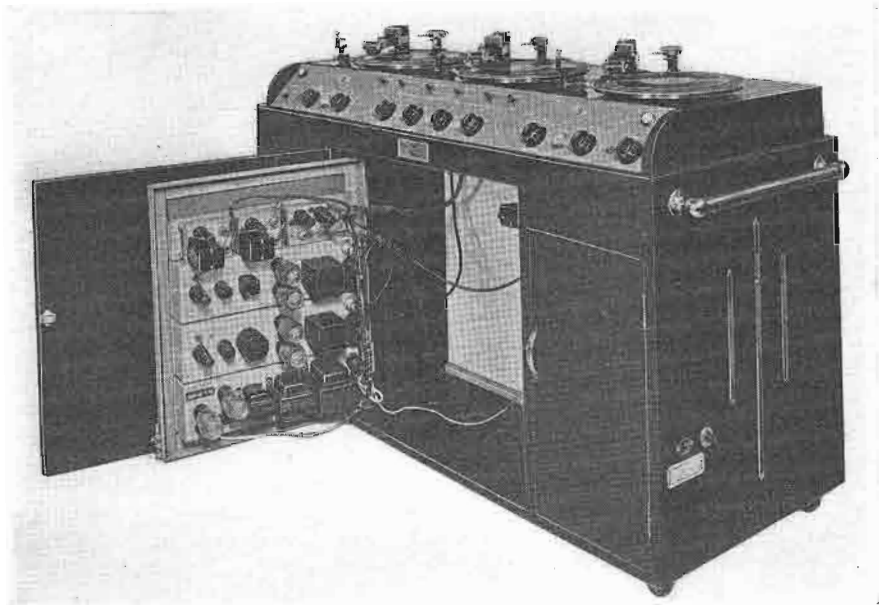

proper groove but the exact portion of the groove is selected by this new, simple and inexpensive scheme. This arrangement involves a large plate with "V" shaped cuts around its edge. The plate rests on the turntable but provision is made whereby it can be stopped without stopping the turntable; the record, of course stopping with this plate. On the console top beside each turntable a stop or "trigger" is mounted in such a position that its bolt can engage with the cuts on the edge of the plate and when so engaged the plate will idle.

To "spot" any portion of a record a notation is made during a preliminary playing of the dial reading, both main and "second" hands, and the number of the cut (cuts are numbered from 1 to 10) nearest the trigger when the exact desired portion of the record is reached. Thereafter when it is desired to start the record at this particular point it is only necessary to engage the trigger with that cut, move the pick-up arm across

the record until the dial shows readings as noted and there place the pick-up on the record. When the trigger is released the plate (and record) assume normal speed instantly. So exact is this system that a record can be "spotted" to start at a given word in the recording, or a single note in a musical score.

Another unusual means for obtaining desired sound effects involves provision for overloading the amplifiers to a controllable degree. By turning up the master gain control to a point where the amplifier overloads, speech and other sounds become distorted and in this distorted form simulate desirable sound effects. With the master gain employed in this way it is of course necessary to provide other means of controlling actual sound output and for this purpose an overall gain control is included at the input to each loudspeaker, the circuit of one of which is shown in Fig. 6. To assist the operator in the use of this feature is a visual distortion indicator in the form of a neon lamp so arranged in the circuit that it will glow whenever on overload condition exists in the amplifier.

Fig. 5. Relay switching arrangement. Fig. 6. Gain control circuit.

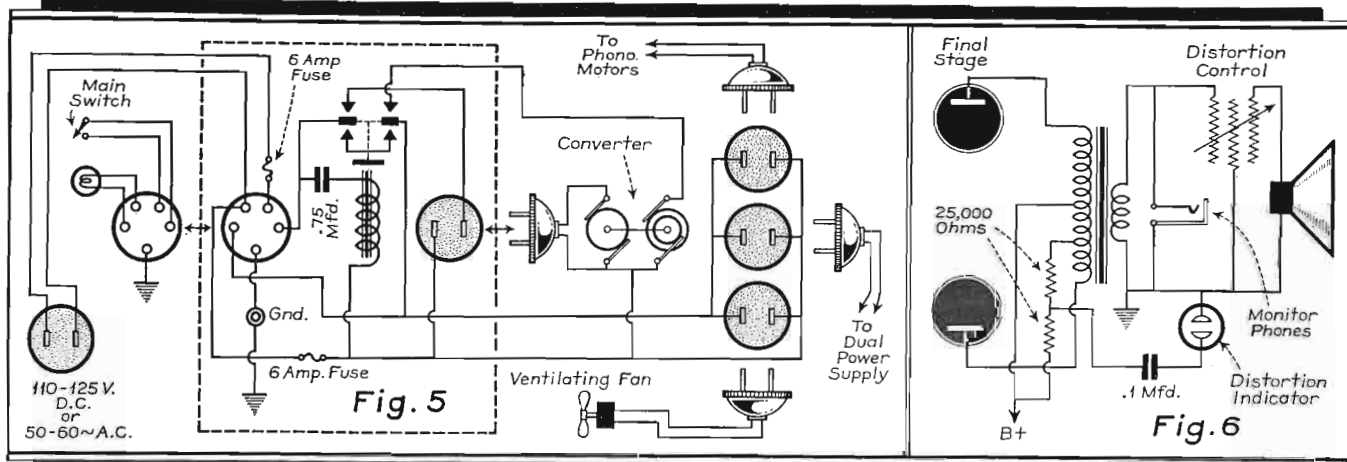

Fig. 1. Block diagram showing general circuit arrangement.

Another feature which has more than justified its use consists of two fixed equalizers which may be cut in and out as desired by means of key switches. One of these cuts off frequencies above 200 cycles, the other cuts out all frequencies below 200 cycles. When not in the circuit resistance networks compensate for the equalizer insertion loss, maintaining the volume level constant. This arrangement has been found to offer definite advantages over variable equalizers in certain applications, particularly where instantaneous changes are required.

Each channel is capable of 30 watts output and each main amplifier provides gain in excess of 100 db.

A control panel arrangement providing instantaneous changeover from one channel to another and from one input to another is, of course, essential for this type of work, as are also facilities for mixing and fading as required. A brief summary of the panel controls as shown in the photographs, will illustrate the flexibility and utility provided in this design.

Directly in the center are the noiseless mixer-fader controls for the four input channels and immediately above are the key switches by means of which any of these inputs are cut in on either of the two main amplifiers. When thrown to the up position these switches connect the corresponding inputs to main channel "A", the controls for which are at the left and the loudspeaker is also at the left of the operator. To avoid confusion the etched line above the switches extends to the right where its con-

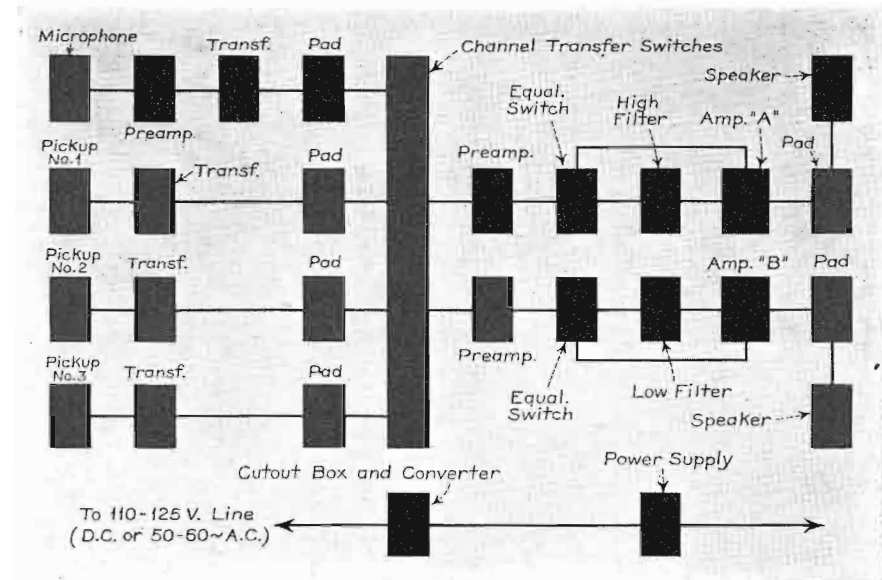

controls are located. These amplifier controls consist of a master gain control, distortion regulator control and distortion indicator lamp. The "hi" equalizer and "lo" equalizer switches are conveniently placed, on either side of the row of input channel switches. At the extreme left is the master power switch with the main pilot light above it and just to its right a headphone jack for monitoring Channel "A" output. At the extreme right is the speed control for the variable speed turntable and above it is pilot light to indicate when this motor is in service. Next to the speed control knob is the monitor jack for Channel "B". Off-on switches for the turntable motors are located near each turntable on the top of the console.

Flexible as this sound effects console is, there is almost a certainty that future requirements will require some altera-

tions or additions. This is one of the reasons that every unit comprising the assembly is provided with plug input and output and all interconnections made by means of cable plugs. Thus each of the three preamplifiers, the two main amplifiers, the loudspeakers, the distortion regulating output networks, the equalizer networks, the power-supply unit, the individual input channel transformers, and the a-c, d-c power system including the converter, can be removed bodily and other units substituted without the use of a soldering iron and with the expenditure of only the time required in loosening their mounting bolts or screws.

With twelve productions per week, put on at the studios of eight different stations in and around New York City these consoles are easily rolled into a truck, transported to the stations and there rolled directly into the studio. Completely self-contained and with operators trained in their use, they are adding their daily bit to the excellent work being carried on by the W. P. A. Radio Unit and helping to overcome at least some of the obstacles encountered in such a comprehensive schedule as this organization is conducting.

APARTMENT HOUSE TELEVISION

Negotiations for the permanent installation of individual television outlets in every apartment are now in progress between Radio Corporation of America and Twenty Park Avenue, the new 23 story apartment house located at the northwest corner of Park and 35th Street, New York City, it is announced by Pease & Ellimen, Inc., renting agents for the structure. When completed, this will mark an advancement for general consumer distribution of television usage in the metropolitan area.

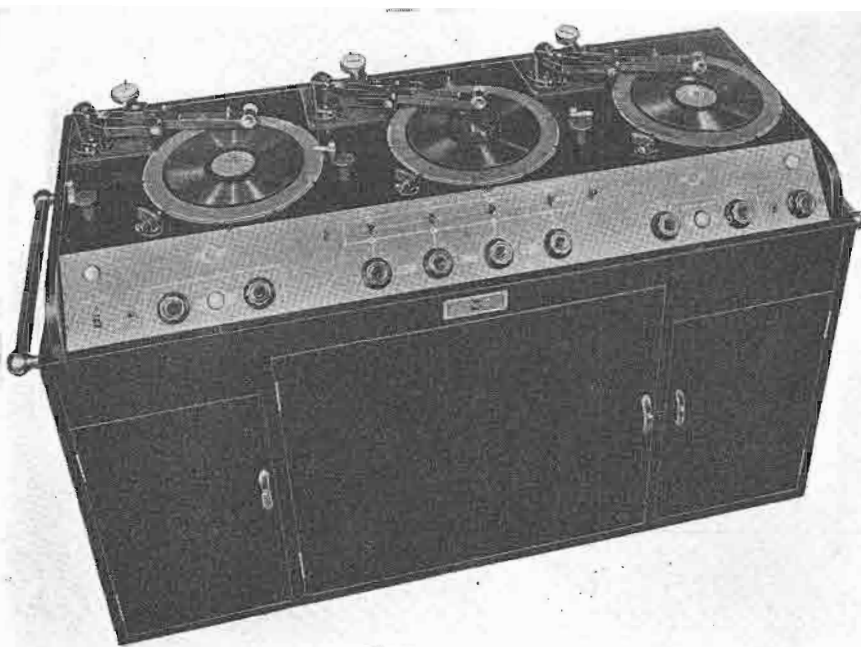

Fig. 3. A third view of console showing turntables and controls.



Left: R. M. Wilmotte.
Top center: Neville Miller.



Top right: Edwin M. Spence.
Left: Edward M. Kirby.

THE N. A. B.

THIS year's Annual Convention of the National Association of Broadcasters is being held at the Hotel Ambassador, Atlantic City, N. J., from July 10-13. Advance registrations indicate an all-time record in attendance.

This will be the first convention since the reorganization of the Association and the first held since Mr. Miller was elected president. The present staff includes: Neville Miller, President; Edwin M. Spence, Secretary-Treasurer; Andrew W. Bennett, Counsel; Edward M. Kirby, Director of Public Relations; Joseph L. Miller, Director of Labor Relations; Paul Peter, Director of Research; Raymond M. Wilmotte, Acting Director of Engineering, and Everett E. Revercomb, Auditor.

Two things are outstanding in interest: the adoption of the new NAB Code and Standards of Practice and a full report of the copyright committee which will negotiate a new contract with ASCAP before January 1, 1941, when the present contract expires.

Speakers on the program are: Gov-

Right center: Everett E. Revercomb.
Below: Andrew W. Bennett.



CONVENTION

ernor Carl Milliken, secretary of Motion Picture Producers and Distributors of America, Inc., who will discuss the philosophy of self-regulation; James G. Stahlman, retiring president of the American Newspaper Publishers Association, who will talk on "Press and Radio in a Democracy"; Hon. Elmer F. Andrews, Wage and Hour Administrator, who will discuss "Wages and Hours and the Broadcasting Industry"; Orrin Dunlap, radio editor of the *New York Times*, who will discuss "The Possible Future Effect of Television and Facsimile on Standard Broadcasting"; Joseph Marty, executive secretary of the Radio Servicemen of America, who will speak on "The Missing Link in Broadcasting."

The banquet will be held Wednesday night. In an adjacent studio, Mr. Miller and Mr. Stahlman will participate in a network broadcast, together with Will Hays, who will be picked up from Hollywood. Their subject, "The Three Mirrors of America—The Press, the Motion Picture, the Radio."

Left bottom: Joseph L. Miller.
Below: Paul Peter.



HOLYOKE HOOK UP WIRE



Photo
Courtesy
RCA Mfg. Co.

for television receivers

Television models are now on the regular production line in several radio receiver manufacturing plants. More important, they are efficient in operation . . . and the public is buying them.

Holyoke has contributed to Television by supplying the proper types of fine quality, high heat-resisting rubber covered low loss hookup wire. Despite the "high falutin" adjectives we use when describing this hookup wire—remember—it costs no more than less efficient brands. In fact, you must use the right hookup wire in television sets . . . or else!

We invite those engineers with radio receiver manufacturing plants who have not already done so to write at once for full particulars. Or, let us have your specifications for price quotations.



Double rubber covered wire, each sheathing 1/16" thick, capable of 20,000-30,000 volts breakdown, exceeds AIEE standard requirements, ideal for television.

Low loss, low capacity rubber covered stranded conductors with RMA color coded braid, either saturated or fire resisting impregnation.

There is a Holyoke wire, cable or cordset available for every radio and electrical application. Shielded wires and harnesses a specialty.

HOLYOKE WIRE & CABLE CORP., 730 Main St., Holyoke, Mass.

Holyoke Wire & Cable Corporation

TELEVISION ENGINEERING

Registered U. S. Patent Office

TELEVISION

Part IV: The Cathode-Ray Tube
as a Television Reproducer

THIS installment will deal only with the cathode-ray tube as a television reproducer, although there are many mechanical systems by which the separate picture elements can be reassembled at the receiving end. This does not mean that the mechanical systems hold no promise for the future, but rather that in the United States at the present time practically all of the activity is confined to cathode-ray reproducers. The major limitation of the cathode-ray tube, as will be pointed out later, is the lack of light, and the mechanical systems have advantages in this regard due to the fact that they control a powerful local light source such as an intense incandescent lamp, an arc, or the recently introduced high-pressure vapor tube. The cathode-ray tube is particularly adapted to the demands of high-definition television, and this fact is largely responsible for its more or less universal adoption throughout the world at this stage of television development.

HISTORY OF THE CATHODE-RAY TUBE

Many people who have only recently become acquainted with the cathode-ray tube may be somewhat startled to learn that tubes bearing that very name have been in existence since 1876. Even earlier than this, Coulomb, and later

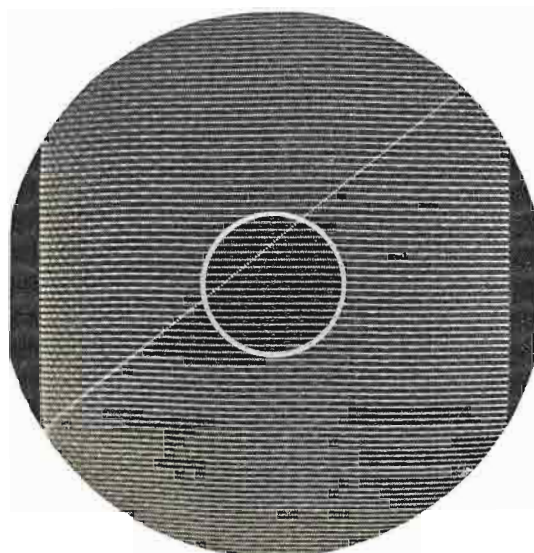

Fig. 5-a. Resolution test pattern. Grid modulated at about 2 mc/sec. Spread vertically to show individual scanning lines. Photo courtesy IRE Proc.

Faraday, observed the effect of application of a high potential between two electrodes within a crudely evacuated glass envelope. The Giessler tube giving interesting color effects within its fancy glass-work was a novel result.

Better exhaust techniques, however, gave rise to the discovery of new effects, one of which was the *cathode-ray* phenomenon, so named by Plücker about 1879. The Crookes tube showed that the "rays" were more properly discrete particles leaving the cathode at right angles to its surface. These particles were later (1890) identified as electrons suggesting that a better name for *cathode-rays* would be *electron beam*, and this has been generally adopted while speaking of the beam, but not the tube itself. Many improvements have been introduced, among them magnetic focussing (1898), the hot cathode for electron emission by Wehnelt (1905), and various arrangements for focussing the beam electrostatically. Intensive research work during the last few years has resulted in bringing the cathode-ray tube from a laboratory curiosity to a tool which has

FUNDAMENTALS

By **F. ALTON EVEREST**

Dept. of Elect. Eng.
OREGON STATE COLLEGE

become indispensable to the communication engineer.

DESCRIPTION OF THE CATHODE-RAY TUBE

The cathode-ray tube as used today in television receivers is shown in Fig. 1. This is one of the largest tubes extensively made and has a screen diameter of 12 inches and employs electromagnetic deflection. In the neck of the tube the electron emitting and focussing elements are assembled constituting what is quite appropriately called the *electron gun*. The beam originating here is attracted by the higher potential on the various anodes and then impinges upon the fluorescent screen. The energy which the electrons have by virtue of their mass and velocity is given up at the screen and some of it is translated to visible light producing a luminous spot.

Fig. 2 shows a partial section view showing the construction of a typical electron gun. At the extreme left the cathode, or the electron emitting device, is shown. The filament within the cathode sleeve is heated by an electric current which in turn heats the cathode sleeve. The end of this cathode tube toward the fluorescent screen is coated with a material which has a high electron emission efficiency when heated.

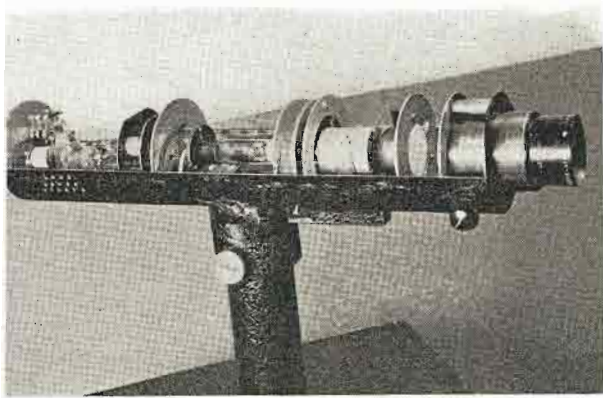
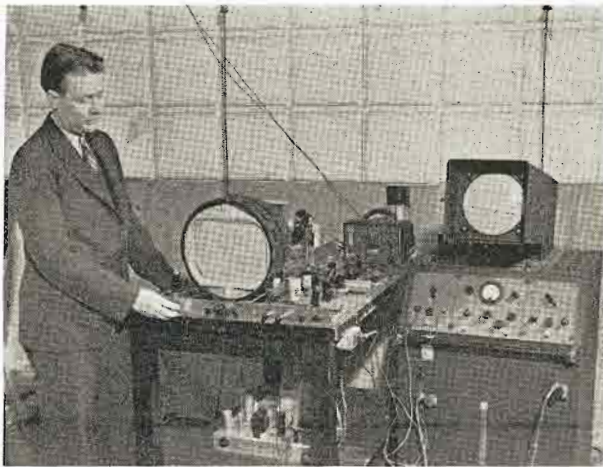

Fig. 4. An RCA projection type cathode-ray television tube. Small image can be projected on 3 x 4 ft. screen. Photo courtesy IRE Proc.



Above: Fig. 6. A 12" tube being tested with a special test pattern. RCA Photo.

Below: Fig. 8. Removing fluorescent material from a furnace. RCA photo.



The first anode, which is held at a very high potential with respect to the cathode, attracts the emitted electrons, and they are pulled through the hole in the cylinder which is usually called the *grid*. It is so called, not because of its structure, but because it performs a function comparable to the grid in the ordinary triode. The intensity of the luminous spot on the fluorescent screen is a function of the speed with which the electrons arrive and the number of electrons. With fixed electrode voltages, the speed remains constant, and the light intensity of the luminous spot is controlled by the variation of the number of electrons in the beam. This is accomplished by the grid. Because it is so much closer to the electron source, a certain low voltage applied to it has the same effect on the electron density of the beam as a very much greater voltage on the first anode. Therefore, a relatively small video signal voltage (say 20 volts) applied between the cathode and grid is sufficient to vary the beam from full brilliancy to cut-off.

The beam next passes through two holes in discs within the cylinder which comprises the first anode. The beam then passes through the second anode which may be either a hollow cylinder with a partially closed end as shown

applied is curved an amount that will retain the spot focus even though the beam is bent in any direction by the deflection system.

Because the beam is composed of many individual electrons travelling in the same direction within a well-defined space, they should react in the same manner as electrons flowing in a conductor occupying the same space. We know that a conductor which has electrons flowing in it is surrounded by a magnetic field and that it will have a mechanical force exerted upon it if another magnetic field approaches it. This is the well-known *motor principle* upon which so many electrical devices depend. This electron beam can thus be deflected to any point on the screen by suitable currents flowing in suitably arranged coils around the neck of the tube. Two pairs of coils whose axes are oriented 90 degrees from each other are used, the whole assembly being enclosed and mounted around tube's neck.

We also know that each electron has a small but definite negative electric charge. Because like charges repel and unlike charges attract, the electrostatic deflection system of plates shown on the right in Fig. 2 will bend the beam. If the top horizontal plate is made positive with respect to the lower one, the beam will be deflected upward an amount

Showing approximate spectral energy distribution compared to eye sensitivity.

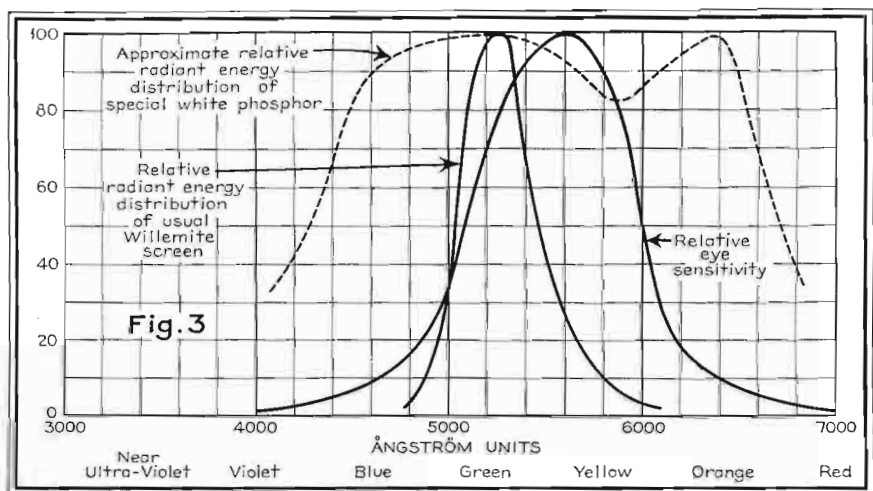

in Fig. 2 or a conducting coating on the inside of the funnel-shaped portion of the glass envelope. In either case, the electrostatic equipotential surfaces are so arranged and adjusted that the electrons in the beam may be brought to a very fine focus at the fluorescent screen. The large end of the glass envelope upon which the fluorescent coating is

which depends linearly upon the magnitude of the difference of potential applied. If the plate nearer the reader of the other pair is made positive with respect to the far plate, the beam would be deflected toward the reader. By means of these two pairs of plates, the beam may be moved to any part of the screen. The actual requirements and relative advantages of the two types of deflection systems will be covered in some detail in the next installment.

The focussing system is quite effec-

Fig. 5-b. Area within white circle of Fig. 5-a enlarged four times to show detail. Photo from IRE Proc.

tive as demonstrated by the photograph of Fig. 5 (a) and (b) which has been taken from Burnett's paper.⁴ Regular scanning methods were employed, and the grid was modulated at about two million cycles per second. Each of these dots is of approximately the same order of magnitude as an elemental picture area, although the lines have been separated for ease in observation. This enlarged area of Fig. 5 (b) has been taken from the center of the screen and has

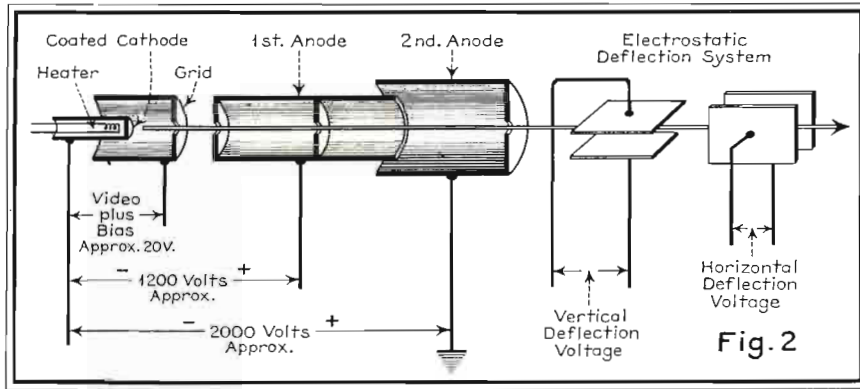

Showing a partial section view of a typical electron gun.

been enlarged four times. A certain amount of de-focussing, blurring, and change in spot shape occurs near the edges of the fluorescent screen, although this effect is not serious. Fortunately, also, the center of interest usually lies in the center of the picture.

LUMINESCENCE

The law of conservation of energy states that energy may be transformed from one form to another, but can be neither created nor destroyed. Energy can exist in many invisible forms. For instance, a small amount of current can be passed through the filament of an incandescent lamp causing a radiation of energy, but the effects of the energy cannot be seen until enough current is passed to make the filament become white-hot and radiate energy within the visible spectrum.

In nature, there are many substances which have the power to change invisible ultra-violet radiation energy or cathode-ray energy into visible light. The study of this phenomenon is in general known as *luminescence*. This may be broken down into two parts, *fluorescence* and *phosphorescence*. *Fluorescence* is an emission of luminous radiation which stops as soon as the exciting stimulus is removed. *Phosphorescence* is that luminous radiation which persists after the excitation has been removed. For example, if a sheet of paper were coated with a certain luminous coating, it would appear white in daylight and be invisible in the dark. However, let some ultra-violet light fall upon

Fig. 1. Comparing 12" television tube with a small metal tube. Both tubes are used in same receiver. RCA photo.



it and it fluoresces with some characteristic color. When the ultra-violet light is removed, the color continues, dying away slowly. This latter is called *phosphorescence* or after-glow. Phosphorescence continues for days or even weeks with certain substances. It is believed that *fluorescence* is associated

with a change within the molecule itself while *phosphorescence* is associated with the transit of electrons from one molecule to another.

The coatings used on television cathode-ray tubes rely principally upon the fluorescent effect and, hence, are usually called fluorescent coatings. The after-glow or time lag caused by the phosphorescent effect is, in fact, usually very detrimental in television pictures. For instance, a moving part of the image would leave an eerie trail behind it. A ball thrown would appear to have a tail like a comet. Suitable screen materials should have what is termed *short persistence* or *medium persistence* characteristics. Phosphorescent characteristics of several substances as given by Levy and West¹ are:

Material	Duration of Phosphorescence
Calcium Tungstate	8 microseconds
Willemite	2-8 milliseconds
Zinc phosphate	About 0.25 second
Zinc sulphide with nickel	Fraction of 1 micro-second.

A screen whose relative brightness decays to within 10% of "black" in about 15 milliseconds is deemed satisfactory for television reception, and it would fall under the medium persistence classification.

COLOR OF EMITTED LIGHT OF FLUORESCENT COATINGS

The screen that has been used very extensively for general steady-state os-

(Continued on page 22)

Fig. 10. A television type cathode-ray tube undergoing life test. RCA photo.



Above: Fig. 7. A 12" cathode-ray tube being subjected to factory tests. RCA photo.

Below: Fig. 9. Manufacturing process of joining shank and tube. RCA photo.

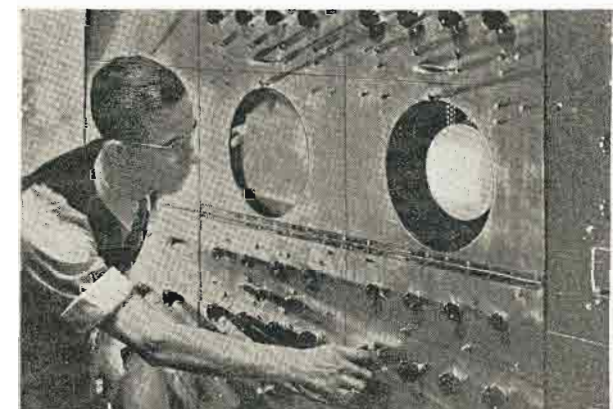
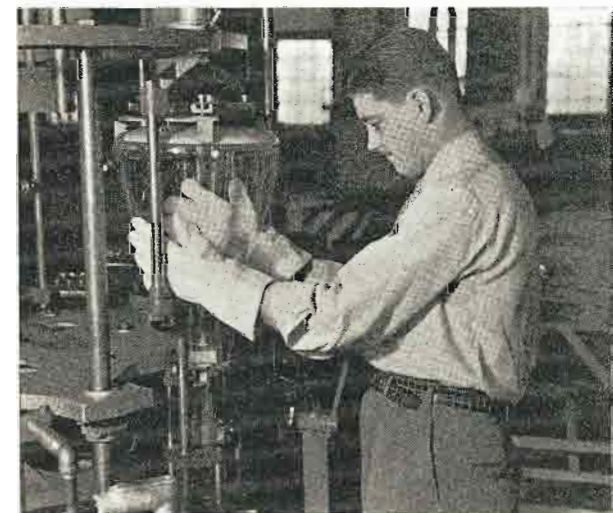

TELEVISION ECONOMICS

I. TELEVISION BROADCAST RECEIVERS

I-1 Chassis

Television receiver construction resembles broadly that of present-day audio broadcasting receivers. That is, the receiver consists of one or more metal chassis on which are mounted component parts and tubes, which are appropriately interconnected on the lower surface of the chassis to each other and to smaller component parts. The major differences from audio receivers include the increased amount of power generally used (falling in the 150-350 watt range or higher depending on the particular circuits which are used and the picture size) and the generation in the receiver of kinescope voltages of the order of 5,000 volts. Where more than one chassis is used, practice has not been standardized as to the division of parts between the respective divisional chassis. In some cases the radio-receiver circuits may be handled on a single chassis and the deflection circuits on another chassis. The magnetic deflection yokes and the kinescope supports may be mounted separately or may form a part of one of the component chassis. Obviously suitable protection against high-voltage shock is to be provided in the form of electro-mechanical interlocks which open power-supply circuits, and perhaps discharge high-voltage condensers whenever the interior of the receiver is made accessible.

From time to time various suggestions have been made for the further protection of such receivers. Some of the methods that have been considered include the exclusive use for high-voltage circuits of suitable high-tension wiring of the type used in oil-burner ignition systems or the like, the conductive connection of the chassis to each side of the power line through a resistance of sufficiently low value to prevent an undue rise in chassis voltage resulting from high-tension leakage with the accompanying hazard of shock through personal contact with control shafts or the like which are connected to the chassis, as well as rigid rules for the testing of all condensers on alternating current and at a voltage in excess of the normal maximum voltage. It has further been mentioned that appropriate insulating bushings are desirable on the high-tension secondary side of the power transformers and that such transformers may preferably be housed in perforated casings to prevent

Part VI

trouble from internal pressure in the event of a short circuit and any resulting considerable evolution of heat within the casing.

Under competitive conditions, a tendency to minimize some of these or similar safety measures may occur but is regarded as economically undesirable. In the event that the high voltages in a television receiver shall cause actual hazard or even annoyance (not to mention psychological discomfort) to the user, the loss in television receiver sales, particularly in the early days of television, may far out-weigh the saving in receiver construction. Engineers and

By

Dr. ALFRED N. GOLDSMITH

Consulting Industrial Engineer

the industry broadly will be well advised to maintain maximum safety standards in television receivers, not only as a matter of sound practice and consideration for the user but as well in the interests of the good reputation and direct returns of the industry.

I-2 Receiver Tubes

The tubes used in television receivers resemble in part those used in present audio broadcast receivers. The chief differences lie in the considerably greater total number of tubes and in the adaptation of some of these tubes to ultra-high-frequency operation and for the wide modulation frequency bands corresponding to the video signals.

Since the number of tubes in the television receivers averages three to five times that in the audio receiver, the corresponding required power supply is greater—a factor thoroughly justifying an interested and cooperative attitude toward television on the part of the public-utility organizations. Any power company is fully warranted in reducing electrical noise originating on its lines and otherwise cooperating with the television users in the light of the increase in residential load thus to be anticipated.

The standard type of tubes used in television receivers is largely employed under average conditions and with average life. The ultra-high-frequency

tubes are particularly designed to have as low an inter-electrode capacity, as large an amplification factor, and as low a noise level as possible. It has in fact been suggested that an appropriate "figure of merit" for u-h-f tubes is the ratio of the transconductance to the sum of the input capacity and the output capacity of the tube (or some closely related quantity).

Since performance of television receivers may become somewhat critically dependent upon the condition of the tubes, manufacturing groups and service men may appropriately suggest that the user consider replacement of all tubes in the receiver, as a unit, on a reasonable schedule. A parallel case is that of a fine piano which should certainly be tuned on a definite schedule. The gradual deterioration of television performance may pass unnoticed for a time but the improvement resulting from a thorough overhauling and general replacement of expendable parts (e.g., tubes) is very evident to the user and will prove helpful in maintaining the appeal and reputation of the corresponding service.

I-3 Kinescopes and Pictures

Kinescopes

The cathode-ray tube, which enables the translation of the received television signals into the visible image in motion, may be regarded as the central component of the electronic television receiver. Such tubes are termed "kinescopes," "oscillights," "videotrons," "TCR tubes," and the like. Of necessity the receiver circuits are built appropriately to actuate this important device. Essentially it consists of an evacuated envelope enclosing an electron-emitting source or cathode, a succession of anodes generally at progressive increasingly positive potentials enabling the acceleration and control of the electron stream, electron-optical arrangements (which may overlap with the preceding elements) for forming a narrow pencil of electrons which is sharply focused on a fluorescent screen, a modulation control element whereby the intensity of the electron pencil may be systematically and accurately varied in accordance with the video signal or blanked out, and as previously stated, a fluorescent screen upon which the final luminous image is formed. Elements for systematically deflecting the electron stream may be enclosed in the tube

or placed externally. Accordingly, the production of kinescopes is a specialized art which can be presented only in outline in the following, where the individual elements of the kinescope will be considered in sequence.

The cathode consists of a metallic surface (e.g., nickel) upon which or within which alkaline-earth oxides are held as the electron emitter. In a certain European kinescope, a filament-type cathode is provided with a cup at its tip, one millimeter in diameter and filled with the emitter. Alternatively, in American practice, a sprayed coating on the cathode consists of about 10 milligrams per square centimeter of surface of a mixture of strontium and barium carbonates in amyl acetate together with a small amount of a binder such as nitro-cellulose. However, oxides, peroxides, hydroxides, nitrates or similar salts of the alkaline-earth metals may be used. After heating of the cathode coating, this becomes typically about 40% of strontium oxide and 60% of barium oxide. There are many available processes for the construction and later activation of the cathode.

An internal heater is preferred to bring the metal cup or emitter support to the necessary temperature. Illustratively, such a heater consists of several inches of tungsten wire having a diameter of less than 0.01 inch, wound in a double non-inductive spiral, which is then insulated by a baked coating of alumina 0.02 inch thick. The cathode heaters generally consume in the neighborhood of 5 watts at several volts.

The assembly of accelerating, beam-restricting, and beam-focusing electrodes near the cathode constitutes the so-called "gun." The gun must be carefully designed in accordance with the recently developed technique of electron optics, and then checked experimentally against systematic variation of the more important design factors. Broadly, the electron gun depends for its focusing action on an arrangement of successive coaxial cylinders forming an electrostatic lens which focuses a small and highly concentrated electron spot on the fluorescent screen. By appropriate design, what is actually focused on the screen is not the active emitting spot on the cathode but the image of a considerably smaller electron-path cross-over located very near to the cathode which may optically be regarded as the pupil of the system. These bi-potential electrostatic lenses are best checked by performance tests, and particularly as regards the minimizing of the electron-optical aberrations of the system. The "electrolytic-trough" method of studying potential distribution in the lens is also useful in practice. It has been found that the

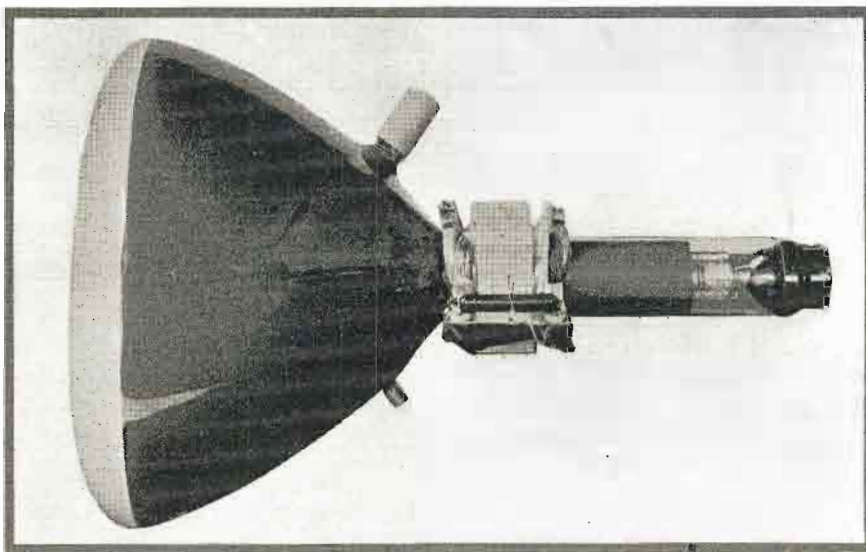

A television type cathode-ray tube used by Pye Ltd., London.

lens aberrations can be reduced not only by appropriate dimensioning and placement of the cylindrical electrodes but also by suitable shaping of certain of these electrodes as particular surfaces of revolution. Ideally, the electron spot should remain focused on the fluorescent screen independently of the position of the spot on any part of the screen area, regardless of instantaneous brightness of the spot (beam current), and despite changes in power-supply voltage. It is to be expected that electron optics, already at a highly practical point of usefulness, will be further perfected by detailed development. It is also clear that the kinescope gun is an exact device, and that appropriate quantity manufacturing methods for such electron-optical instruments will call for increasingly precise equipment. While it is not of practical importance at this time, it is of interest that electron mirrors as well as lenses can be built, that they can produce excellent picture quality, and that they appear susceptible of combination with electron lenses to form even more highly corrected systems.

In order to control the electron-beam current and therefore the instantaneous brightness of the scanning spot, a modulating or grid element in the gun is used. This operates with a constant grid bias (generally in the range from 50-250 volts) and with a video grid signal (generally in the range from 5 to 30 volts, depending upon the size of the picture and other factors).

The beam travelling on its way to the fluorescent screen must be deflected according to the scanning regime. Standard practice requires that line deflections be horizontal from left to right and frame deflections vertical from top to bottom. The beam is blanked out

on its return at the end of each line and of each frame, an appropriate fraction of the scanning cycle being allotted to this purpose. The deflecting means may be electrostatic or magnetic; and there are differences of engineering opinion as to the more desirable form. Electrostatic deflection is accomplished by pairs of (generally) parallel plates within the tube, while magnetic deflection is accomplished by a pair of electromagnets mounted on a yoke and external to the tube. In each case the design must be such that there is no noticeable mutual reaction between the vertical and horizontal deflecting controls, nor may the deflection be dependent upon the video control of the beam. As indicated previously, there are differences of opinion as to the most desirable deflection means, the advocates of electrostatic deflection stating that the deflection plates add little to the cost of the tube whereas the magnetic deflection yokes are expensive, require a constant-current supply, necessitate the use of an iron-core coupling transformer flat up to nearly 200 kilocycles, and create difficulty in getting the correct deflecting wave form. The advocates of magnetic deflection emphasize a claimed shorter usable length of the magnetic-deflection tubes, a decrease of defocusing at the edge areas of the picture because of greater obtainable uniformity of the deflecting field and a larger convergence angle of the beam, and a diminished defocusing of the spot for high beam currents resulting from the last-mentioned cause. They also weight the relative difficulties differently, and reach the opposite conclusion from those preferring electrostatic deflection.

A practical problem in connection with deflection is the relationship between the permissible angle of swing of the electron beam and the quality of the image at the edges of the picture.

It is desirable that the beam shall swing through a wide angle in order to avoid excessive length of the tube. However, electron optical considerations indicate that the image quality can be maintained only with increasing difficulty as the angle of deflection of the beam is increased. Defocusing near the edges of the screen may readily occur particularly when beam deflections of the order of 30 degrees or more from the central axis are used. It has nevertheless been claimed that a satisfactory kinescope produced in Europe utilizes magnetic deflection on a screen 10 inches wide though the tube length is restricted to 11 inches! In another European kinescope having electrostatic deflection and focusing, the tube, although 14.4 inches in diameter, is only 18 inches long.

Before considering the fluorescent screen, it should be pointed out that unusual care is necessary in the evacuation of kinescopes. Further, in view of their considerable dimensions, the amount of space required in the factory for the manufacturing processes and for test, storage, and shipment of these tubes, constitutes an economic problem. Space must also be provided in the factory for the storage of blanks, the manufacture and adjustment of guns, the chemical processes connected with cathode coating, further processes involved in depositing colloidal graphite in the interior of the tube for the final anode, for equipment for the manufacture of the fluorescent material and its deposition on the screen area, as well as for the evacuation of the assembled kinescopes. It may be here added that colloidal graphite is used for an anode coating on the pre-cleaned glass surface because it readily forms a tenacious, conductive, homogeneous, and dark-colored film which has a helpful "getter" action and also has a low photoelectric emission. The production of these tubes therefore is a more elaborate and costly process by far than the production of the average vacuum tube. In the case of a certain European manufacturer of electrostatic-deflection kinescopes, 12-inch tubes of this type were made of soft glass and coated internally with lead sulfide by precipitation (rather than graphite). Six tubes were exhausted at a time, the process taking one and one-half hour per tube, and 30 tubes being produced per week. An onion-shaped section at the large end of the tube was preferred in this case to funnel shape for structural-strength reasons. At the present time such tubes retail in America at a cost depending on picture size and image color. Although quantity production may cut the cost, it is not certain how far a precision product of this sort, involving considerable individual

handling, can be reduced in cost as the manufactured quantity is increased. For example, the exhaustion process in itself is fairly elaborate. The actual exhaustion is usually carried out in two stages. A rotary oil fore-pump carries the vacuum to about 0.1 mm of mercury. A mercury or oil condensation pump, equipped with the usual liquid-air trap, carries the vacuum down to about 1 millionth of a millimeter of mercury or better. The tube blanks are generally of Pyrex, and connecting tubing of large diameter is necessary to enable reasonable exhaust speeds. The metal parts are assembled by spot welding with particular care to ensure chemical cleanliness of all parts. The tube itself is baked at a temperature of 450 degrees C. High-frequency induction is used to outgas the gun, the cathode is then activated, and a suitable getter (for example, a mixture of aluminum and barium) is flashed, after which the tube is sealed. There are numerous details and possible variations of procedure, as well as desirable precautions in these processes, which cannot conveniently be here given but which influence both development and manufacturing costs.

Means must finally be provided in the kinescopes whereby the modulated scanning electron beam shall produce a visible image. A number of methods have been suggested including the thermal effect of the electron beam or the electrostatic effect of the beam. In the case of the thermal process, the electron energy is used to incandescence (or brighten the incandescence of) a suitable surface or structure of low thermal capacity and high heat-radiating capacity. When the beam is used electrostatically, its effect may be directly employed, or alternatively multiplied by the production thereby of intense potential gradients in a restricted region. In one proposed method of electrostatic utilization of the beam, minute light valves electrostatically operated with extreme rapidity are suggested. Such light valves have been described in the form of extremely small and thin metallic vanes or conducting hairs. An otherwise constant beam of light is then thrown upon this valve-covered image-forming surface, and the image is then suitably reproduced by lens action on a screen. In another proposed electrostatic method of using the beam, an assembly of electrostatically-affected tiny crystals, or a single equivalent crystal plate, is caused to control the position of the plane of polarization (or a related characteristic) of the light passing through the crystalline medium, namely zinc blende (that is zinc sulphide). One of the usual optical methods of translating a change in the plane of polarization of a light pencil into a

corresponding change in its intensity is then applied to create the image elements or the integrated entire image. All of the preceding processes are in the development stage, and have not reached the market in simplified and commercial form. Accordingly there need be considered at this time only a third effect of the electron beam, which is widely and successfully used commercially, namely the production of fluorescence in certain crystalline media and mixtures.

(To be continued)

• • •

TELEVISION FUNDAMENTALS

(Continued from page 19)

cillographic work is the Willemite screen. This substance is found in nature and can also be made synthetically. This material has been so popular because practically all of its energy is developed in a region in which the eye is very sensitive. Fig. 3 shows the relative eye sensitivity plotted against the wavelength of light in Angstrom units. It will be seen that the eye is most sensitive to yellow-green light. The spectral energy curve of Willemite is shown, and it will be seen that almost all of its energy is concentrated in the green, where the eye is very sensitive.

Although cathode-ray tubes giving green light were and are used in many experimental television receivers, the fact remains that a more suitable and pleasing color would be white. The approximate spectral energy distribution of one mixture is shown as a broken line in Fig. 3. This is an inefficient arrangement because, although the white screen may have the same efficiency from the energy standpoint, much of this energy is expended at wavelengths at which the eye is relatively insensitive and, therefore, wasted as far as apparent light intensity is concerned. Even though the white screen is inefficient, the public will insist upon something very close to white because of the comparison to motion pictures which television is always subjected to.

Other difficulties confront the white television screen. For instance, the predominating hue shifts to a longer wavelength with higher intensities. The bright parts of the image may have a cast that is somewhat different from the less bright portions. In general, however, this effect is more pronounced at the lower intensities as almost any fluorescent coating tends to appear white at extremely high intensities.

The extraneous illumination falling on the screen also influences the apparent color. A screen that appears white in a totally dark room may appear tinted if an incandescent lamp is burning in the

(Continued on page 24)

SOUND MOTION PICTURE FILMS IN TELEVISION

Part III

IN discussing in last month's article the ability of 16-mm films to provide the quality of picture image that is needed for television broadcasting, the writer was dealing with facts that many of his readers could confirm from their own experience. Amateur 16-mm movie cameras and projectors are widely distributed, and give, on the whole, a good enough performance to justify the assertion that similar films, used with refined equipment and methods, can provide all the detail that can be transmitted over a 441-line television system.

The facts regarding sound reproduction to be presented in the present article are much less widely known, and must be accepted largely on the basis of the writer's experience. Comparatively few engineers have ever heard high-quality 16-mm sound films reproduced on playback equipment good enough to reveal the full quality of the recording. Indeed, it is more than likely that any reproduction from 16-mm film that the reader may have heard was of mediocre quality.

At the outset it is important to make clear the reasons for the state of affairs referred to above.

Projection equipment for 16-mm sound films until recently has all been of the small portable type, and has been manufactured under definite and even appropriate economic limitations. These limitations made it impossible to use optical systems, amplifier components, and loudspeakers comparable in quality to the parts used in 35-mm theatre reproducing equipment. Because of weight limitations on mechanical parts, especially flywheels, steadiness of film motion has not been of a very high order. The result has been that, with one notable exception, the machines on the market have had inherent characteristics, particularly as regards frequency response, that did not compare well with those of 35-mm theatre equipment.

Engineering effort has done much, and undoubtedly will do a great deal more, to overcome these limitations of 16-mm portable sound projectors; but the fact remains that the majority of the machines now in use, while fairly satisfactory for speech, give musical reproduction far below present broadcast standards of quality. Any estimate of the possibilities of 16-mm sound recording and reproduction arrived at by listening to films played on such projectors naturally is unreliable.

In the absence of really high-quality

16-mm film playback equipment, and in view of the prospective market for 16mm sound films, producers in the past have had little reason to expend effort in improving film quality. The result has been that most 16-mm sound films that have been distributed commercially are capable of flat response only to about 4000 cycles. Thus at best they are definitely unsuitable at sources of sound for broadcasting.

When the above commercial limitations are set aside and sound is recorded on and reproduced from 16-mm film with the best equipment

By JOHN A. MAURER

THE BERNDT-MAURER CORP.

available at the present time, the quality obtained is of an entirely different order. Flat response to 6000 cycles, with useful response to 8000, is obtained on prints made with conventional types of film stock. Finer grained types of stock for printing permit extension of the range of flat response to 8000 cycles. These figures refer to records made at the standard 16-mm film speed of 36 feet per minute. Naturally, any increase of the speed of film travel, such as would be involved in a change of camera speed from 24 to 30 frames per second, as has occasionally been proposed, would give a proportionate increase in the frequency range available.

16-mm film records made by the best techniques at present available have low distortion, comparable in amount to that of excellent disc recordings of the same frequency ranges, and give similar low background noise levels in reproduction. The noise is made up in about equal parts of hiss from the photoelectric cell, hiss due to film grain, and crackling noises due to dirt adhering to the film. Improvements in the fineness and uniformity of film grain which at the same time result in much smoother film surfaces are rapidly reducing the importance of the two latter components of the noise.

Films having the high-quality characteristics described above have been demonstrated publicly on two occasions: once by R. W. Benfer, of Electrical Research Products, Inc., at the Detroit Convention of the Society of Motion Picture Engineers in November, 1938, and once by the writer at the Hollywood Convention of the same Society in April, 1939.

16-mm reversal film, exposed in a

camera of the newsreel type, is capable of flat response to 5000 cycles, with useful response to 6000. The less rapid types of negative film, used under the same conditions, give about the same performance. The noise level of records on negative type film is about 6 decibels higher than that of records on the slow films generally used for sound recording, but is not high enough to be objectionable in comparison with the natural noises that are almost always present when newsreel material is being recorded.

Those who have read the second article of this series will recall that one of the requirements set down as necessary in any standardization of film dimensions for television was the potential ability to provide sound reproduction flat to 15000 cycles. In view of present trends in film research, the writer believes that it would not be safe to predict that 15000 cycles can *not* be recorded and reproduced with a film speed of 45 or even 36 feet per minute; but he believes, nevertheless, that any complete set of standards should make possible an ultimate increase of speed of film travel to the order of 60 feet per minute (40 frames per second) if this should become necessary. A speed of 60 feet per minute would definitely permit recording and reproduction with a 15,000-cycle range. Provision for such increase of film speed is a matter of film-scanner design, and will be discussed, with definite suggestions, in the next paper of this series.

For the present let us consider the available sound quality in relation to present needs, and particularly in relation to present sound broadcasting practice. It has been stated that a flat response to 8000 cycles is available for higher quality programs, and a flat range to 5000 cycles for subjects of the newsreel type. Present sound broadcasts in New York City occasionally provide a frequency range of 8000 cycles, but the range is usually of the order of 6000 cycles in local programs and 5000 cycles in broadcasts received by wire line from other cities. These statements are based on observations made by listening to broadcasts by means of a high-quality band-pass receiver, with a number of sharp cutting low-pass filters available for insertion in the audio circuit. Commercial receivers, as is well known, do not provide flat response above 4000 cycles except in a few special cases. It is also well known that sound reproduction flat

to 8000 cycles or higher must be free from distortion to be pleasing, and that the requisite degree of freedom from distortion is not obtained in the detectors and audio amplifiers of most present-day receivers.

In view of the conditions above cited, and further, in view of the cost of loudspeakers and audio systems capable of giving good performance with a 15000-cycle frequency band, the writer believes that it will be some years before it is feasible to bring the sound associated with television broadcasting to a 15,000 cycle standard in the home. In the interim the quality available from 16-mm films at standard film speed should prove satisfactory to the public, especially since improvement is certain to come from the results of film research now in progress.

The importance of proper reproducing equipment for sound films has been indicated earlier in this paper. Fortunately this equipment presents no unsolved problems. If built in a reasonably massive fashion, with accurate parts, a reproducer for 16-mm film can give as good performance, from the standpoint of freedom from speed variations, as is obtained with 35-mm film. The optical system used to produce the line of light that scans the sound track should employ the best available lenses and should be designed to give a beam not more than .0004 inch in width; but this does not necessitate a cost greater than twenty to thirty dollars for this part. The photocell exciter lamp should be operated on direct current. The photocell amplifier must be of the same quality as a high-grade microphone amplifier, and must be coupled to the photocell by a circuit of low enough impedance to permit flat response.

One recommendation which the writer considers to be of special importance is that as far as possible all sound track used for broadcasting should be of the push-pull type. Push-pull sound tracks are no more difficult to produce than the conventional single sound track. The cancellation of second harmonic distortion which occurs in the process of reproduction makes it possible to tolerate considerable variations in film processing, while maintaining better overall freedom from distortion than can be obtained with single tracks. Inasmuch as it is an easy matter to arrange the reproducing system to function interchangeably and equally well with push-pull and single tracks, the adoption of the push-pull system would not prevent the occasional broadcasting of films having single sound tracks.

The next paper in this series will discuss film-scanner design for television

broadcasting and its relation to the standardization of sound film for television purposes.

TELEVISION FUNDAMENTALS

(Continued from page 22)

room. Added to all this, there appears to be a wide variety of individual ideas as to what a "white" screen really is.

In spite of these difficulties, several fluorescent coatings have been developed which give essentially black and white pictures.¹¹ One method of attack is to mix two or more highly colored substances in such a way that their composite effect is essentially a white. For instance, substances exhibiting blue and red-orange fluorescence will produce white. Progress is being made in this direction, and increasing the luminous efficiency seems to hold real promise. Because the maximum visible light energy emitted is only in the region of 4% or 5% of the electron energy input, there is ample room for improvement.

PROJECTION CATHODE-RAY TUBES

Fig. 4, which is taken from Law's paper,² shows a cathode-ray tube which gives a small, intense image so bright that it can be projected onto a screen giving a 3 x 4 foot projected image. Light may be compared to butter, the greater the area over which it is spread, the thinner it lies. This answers the question often asked as to why a lens system is not used on an ordinary cathode-ray television image tube. It can be done, but the picture gets dimmer the greater the area it is made to cover. This projection cathode-ray tube is designed for high-voltage operation (10,000 volts), high-electron gun current, and a small fluorescent screen image (2.4 x 1.8 inches) which is projected onto a screen for enlargement. With such terrific electron bombardment, the fluorescent screen has a much shorter life than that of an ordinary direct-viewing tube. The progress of the projection tube now seems to be bound up in the development of more durable fluorescent materials.

BIBLIOGRAPHY

- (1) Levy and West, "Fluorescent Screens for Cathode-Ray Tubes," *Journal IEE*, Vol. 79, 1936, pp. 11-19.
- (2) Law, "High Current Electron Gun for Projection Kinescopes," *Proc. IRE*, Vol. 25, No. 8, August, 1937, pp. 954-976.
- (3) Zworykin and Painter, "Development of the Projection Kinescope," *Proc. IRE*, Vol. 25, No. 8, August, 1937, pp. 937-953.
- (4) Burnett, "A Circuit for Studying Kinescope Resolution," *Proc. IRE*, Vol. 25, No. 8, August, 1937, pp. 992-1011.
- (5) Zworykin, "Iconoscopes and Kinescopes in Television," *RCA Review*,

Vol. I, No. 1, July, 1936, pp. 60-84.

- (6) Maloff, "Direct-Viewing Type Cathode-Ray Tube for Large Television Images," *RCA Review*, Vol. II, No. 3, January, 1938, pp. 289-296.
- (7) Laverenz, "Problems Concerning the Production of Cathode-Ray Tube Screens," *Journal of the Optical Society of America*, January, 1937. Reprinted in *Television*, Vol. II, RCA Institutes' Technical Press.
- (8) Wilson, "Television Engineering" (Pitman), Chapter VIII, Cathode Rays and Fluorescence.
- (9) Randall, "The Theory of Luminescence," *Television* (London), July, 1937, p. 408. Abstract of paper appearing in *Royal Society of Arts Journal*, March, 1937, p. 146.
- (10) Parr, "The History of the Cathode-Ray Tube," *Television* (London), February, 1937, p. 85.
- (11) Schmidling, "Fluorescent Materials for Television Tubes," *COMMUNICATIONS*, April, 1939, p. 30.

(To be continued)

CORRECTION

SEVERAL errors appeared in the article "Amplifier Testing by Means of Square Waves," by Gilbert Swift, which appeared in the February, 1939, issue of *COMMUNICATIONS*.

On page 22 the explanatory note on Fig. 2 should read: "Some attenuation at high frequencies. Highly damped, insufficient delay at high frequencies."

On page 23 the sentence beginning in the fifth line of the center column should read as follows: "Insufficient delay at the higher frequencies is indicated by rounding of two diagonally opposite corners of the wave, as shown in Fig. 2."

In Fig. 4 on the same page the caption should be: "Higher attenuation at high frequencies. Highly damped, insufficient delay at high frequencies."
—EDITOR.

TELEVISION PICK-UP OVER TELEPHONE CABLE

ON the evening of May 20 events at the 6-day bicycle race in progress at Madison Square Garden, New York City, were "telecast" by the National Broadcasting Company in a half-hour program of sight and sound. The facilities for carrying the television signals from Madison Square Garden to the National Broadcasting Company were furnished by the New York Telephone Company and Bell Telephone Laboratories as an experiment in television transmission.

The television signals were picked up by NBC "telemobile" unit from the edge of track at the Garden, and were transmitted over existing telephone cables to the Circle central office on West 50th Street and thence over a similar circuit to the NBC studio at Radio City. Special amplifiers, attenuation equalizers, and phase equalizers were provided at the Circle office and at both terminals. The adjustment of the overall circuit was such that the signal was delivered at Radio City without noticeable impairment.

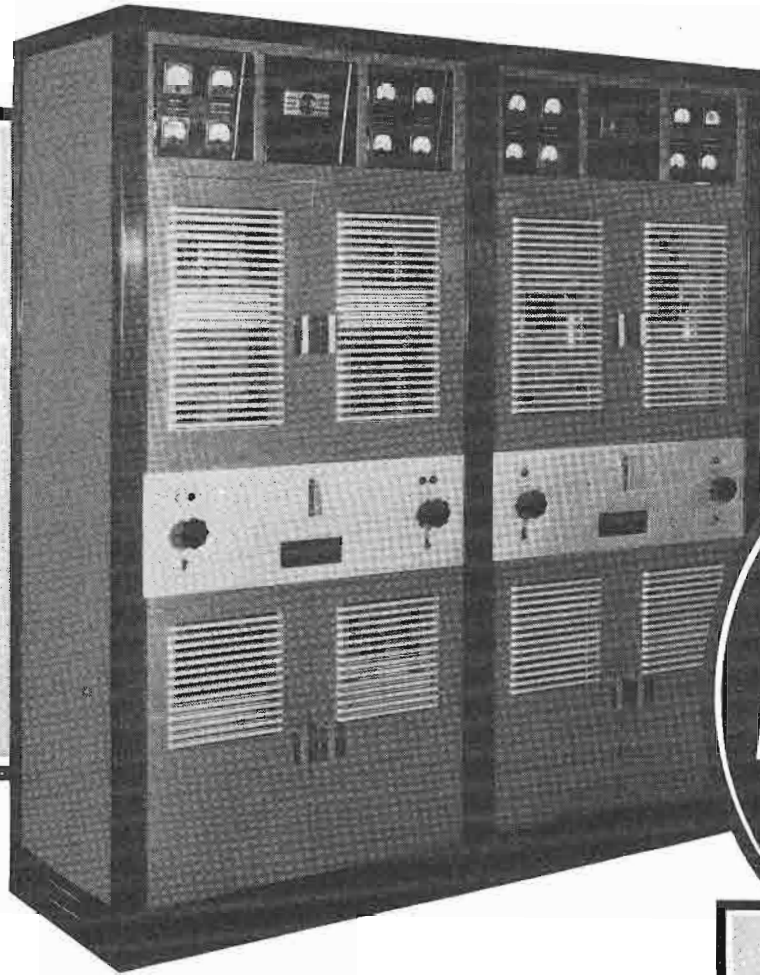

RCA 1-E Transmitter. Consists of 2 units which match in appearance and dimensions and are integrally designed for use together. One is the RCA Type 250-D Exciter Unit—the other an RCA 1 kw. amplifier-modulator unit of new design.

**RCA Announces a
DeLuxe Transmitter
for Regional Stations
A HIGHLY EFFICIENT
1,000 WATT
EQUIPMENT**

The RCA 1-E transmitter is designed for stations operating with licensed powers of 1,000 watts, 500 watts, 500/1,000 watts or 250/1,000 watts. Employing the very latest type high efficiency tubes and featuring straightforward circuits, it is one of the most efficient 1,000 watt transmitters developed to date. It offers the simplest and most nearly foolproof tuning and operating procedure. Uses high level modulation.

The 1-E has many special features—features you will find only in this de luxe equipment. Some of these include a total of 26 meters for the facilitation of tuning and operation, an auto-transformer for compensating line voltage fluctuations, a variable output coupling system for the maintenance of power output at specified value, a dummy antenna for testing operations. The 1-E has an exceptionally complete control system—providing protection not only for personnel and equipment, but also facilitating automatic or manual starting, instantaneous power change-over, etc. This outstanding new transmitter has many other features, too—is equipment you will recognize as definitely superior.

SPECIFICATIONS

- Rated operating power...1,000 watts
- Radio frequency range. .550-1,600 kcs.
- Radio frequency stability... ± 10 cycles
- Modulation capability...100%
- Audio frequency response (± 1.5 db.) 30-10,000 cycles
- Audio distortion (50 to 7,500 cycles) 3% RMS. max.
- Background noise and hum level...minus 60 db.
- Power supply . . . 230 volts, 50/60 cycles, single phase
- Power consumption (nomodulation) 4.8 kw.
- Dimensions (over all) 76-1/4 inches by 25-1/4 inches by 84-1/8 inches
- Weight (approx.) 3,000 lbs.



Broadcast Equipment

RCA Manufacturing Co., Inc., Camden, N. J. • A Service of the Radio Corporation of America

NEW YORK
1270 Sixth Avenue

CHICAGO
589 E. Illinois Street

ATLANTA
530 Citizens & Southern Bank Building

DALLAS
Santa Fe Building

SAN FRANCISCO
170 Ninth Street

HOLLYWOOD
1016 N. Sycamore Avenue

ALL NEW RELAYS by GUARDIAN are DESIGNED here



BEFORE PRODUCTION BEGINS

Guardian's Relay Assembly line in action pictured in the above candid photo, turns out thousands of Relays every day. But before any relay goes into production, Guardian's Engineering Laboratory must design your control and test it in innumerable ways. We must know in advance that your relays will perform as expected. A uniform, dependable, faultless product is the natural result . . . ANY QUANTITY AS YOU WANT THEM, WHEN YOU WANT THEM. No complaints . . . no post-mortems. When seeking a better source for relays, remember it's not the largest factory BUT high quality, fast service and conservative cost that really count.

ENGINEERING LABORATORY—devoted solely to the design of electrical control units from simple to most intricate combinations . . . uniform in size . . . space-saving . . . simple, better and more economical.

Ask Us to Make Specific Recommendations to Fit Your Special Requirements.
Write for Catalog "C" Today!

GUARDIAN ELECTRIC

1623 W. WALNUT STREET CHICAGO, ILLINOIS

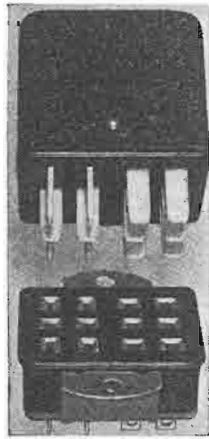

"300" SERIES

A COMPLETE NEW LINE OF SMALL PLUGS—SOCKETS

2 CONTACTS TO 33 CONTACTS

PLUGS WITH CAPS
SOCKETS WITH CAPS

PLUGS WITH BRACKETS
SOCKETS WITH BRACKETS

Ask for Bulletin 300

HOWARD B. JONES

2300 WABANSIA AVENUE, CHICAGO, ILLINOIS



Frequency Measuring Service



Many stations find this exact measuring service of great value for routine observation of transmitter performance and for accurately calibrating their own monitors.

MEASUREMENTS WHEN YOU NEED THEM MOST

at any hour every day in the year

R.C.A. COMMUNICATIONS, Inc.

Commercial Dept.
A RADIO CORPORATION OF AMERICA SERVICE

66 BROAD STREET
NEW YORK, N. Y.

IMPEDANCE MEASUREMENTS

(Continued from page 9)

mum. The mutual impedance can be determined in the following manner:

(1) Tune each element to series resonance as indicated in Fig. 17. The self-impedances between the terminals shown are, therefore, purely resistive and equal to R_1 at element numbered 1 and R_2 at element numbered 2.

(2) Measure the impedance between the terminals at element No. 1 with the terminals at element No. 2, first open, then closed. Call the impedances $Z'_{o/c}$ and $Z'_{s/c}$, respectively.

(3) Repeat the measurements at element No. 2 with element No. 1 first open, then closed. Call the measured impedances $Z''_{o/c}$ and $Z''_{s/c}$, respectively.

(4) Analyze the combination in terms of the equivalent T circuit of Fig. 18. From the equations for this network the value of the mutual impedance, Z_M , is found to be:

$$Z_M = \frac{\sqrt{Z'_{o/c}(Z''_{o/c} - Z''_{s/c})}}{\sqrt{Z''_{o/c}(Z'_{o/c} - Z'_{s/c})}} \dots (9)$$

The mutual impedance in the foregoing method is found from the difference between two numbers that may be large compared with the difference. It is, therefore, sometimes easier to determine it by a more direct method. A rapid check on magnitude, for instance, can be obtained simply by exciting one antenna with a current I_1 , and measuring the resonant current I_2 , in the other. Then, to a first approximation:

$$|Z_M| = \frac{I_2}{I_1} R_2 \dots (10)$$

Coaxial Transmission Lines

The characteristic impedances and propagation constants of coaxial lines are ordinarily found from measurements made at one end with the far end first open, then closed. If the two measured values are $Z_{o/c}$ and $Z_{s/c}$ respectively, then:

$$Z_o = \sqrt{Z_{s/c} Z_{o/c}}$$

$$\theta = \pi l = \tanh^{-1} \sqrt{\frac{Z_{s/c}}{Z_{o/c}}}$$

where Z_o is the characteristic impedance, θ the line angle, p the propagation constant of the line, and l the line length.

In general, one of the two measured impedances has a negative reactance and the other a positive reactance. At frequencies which make the line-length an odd multiple of $\lambda/8$, the magnitude of the two impedances are equal. At frequencies which make the line length an integral multiple of $\lambda/4$, on the other hand, one of the impedances becomes very high and the other very low. At these frequencies it is difficult

to obtain accurate measurements. Neither the characteristic impedance nor the propagation constant changes appreciably with frequency, however, an accurate result can easily be obtained by making measurements at frequencies above and below the desired frequency and interpolating. A check on the characteristic impedance can be obtained by terminating the line in an impedance equal to the computed value and checking the input impedance to see that it matches at the operating frequency.

Balanced Transmission Lines

The technique for measuring impedances that are balanced to ground has not been developed to as great an extent as that for measuring impedances with one side grounded.

The series-resonance methods are relatively easily adapted to measurements of balanced impedances by changing from an unbalanced to a balanced resonant circuit. The balanced counterpart of the series resonance substitution circuit of Fig. 14, for instance, is shown in Fig. 19. The degree of balance required in the settings of the various circuit elements is not ordinarily critical but mechanical symmetry should be approached as closely as possible in order to balance the ground capacitances. The measurement procedure to be followed is essentially the same as that previously described.

The ordinary radio-frequency bridge cannot be used to measure balanced lines directly except when the ground capacitances are negligibly small compared to the direct capacitance between the wires. If it is assumed that the input impedance can be represented by the three-terminal equivalent circuit of Fig. 20, however, it can be used to measure them indirectly in terms of the three component impedances Z_1 , Z_2 and Z_3 . The procedure is as follows:

(1) Short-circuit impedance Z_1 by grounding line A at point of measurement, and measure impedance from line B to ground. Call the measured value Z' .

$$Z' = \frac{Z_2 Z_3}{Z_2 + Z_3} \dots\dots\dots (11)$$

(2) Short-circuit impedance Z_2 by connecting line A to line B at point of measurement, and measure impedance from the junction to ground. Call the measured value Z'' .

$$Z'' = \frac{Z_3 Z_1}{Z_3 + Z_1} \dots\dots\dots (12)$$

(3) Short-circuit impedance Z_3 by grounding line B at point of measurement, and measure impedance from line A to ground. Call the measured value Z''' .



The Pickup of Tomorrow

The Brush Model PL-50 transcription type crystal pickup is truly "the pickup of tomorrow." Program, production and transcription engineers have long desired a pickup with characteristics now available in the Brush PL-50.

- Permanent sapphire stylus with a pressure of only 15 grams.
- High fidelity, 30-10,000 c.p.s.—2 db., harmonic distortion a small fraction of 1%.
- Tone Arm—modern in design and finished in black and chrome.
- No measurable wear of harder material records.
- Acetate records may be played hundreds of times without damage to record.
- May even be used on a wax master cutting.

Model PL-20 provides higher output than the PL-50, also has permanent sapphire stylus; stylus pressure 30 grams; 1000 to 3000 playings on commercial pressings without measurable wear; fidelity only moderately less than PL-50.

Complete Technical Data on Request



PL-50 List \$75.00
PL-20 List \$37.50

THE BRUSH DEVELOPMENT CO.

3318 Perkins Avenue

Cleveland, Ohio

$$Z''' = \frac{Z_1 Z_2}{Z_1 + Z_2} \dots\dots\dots (13)$$

Combining equations (11), (12) and (13) gives:

$$Z_1 = \frac{2 Z' Z'' Z'''}{Z' Z'' - Z'' Z''' + Z''' Z'} = \frac{2}{-\frac{1}{Z'} + \frac{1}{Z''} + \frac{1}{Z'''}} \dots\dots\dots (14)$$

$$Z_2 = \frac{2 Z' Z'' Z'''}{Z' Z''' + Z'' Z''' - Z''' Z'} = \frac{2}{\frac{1}{Z'} - \frac{1}{Z''} + \frac{1}{Z'''}} \dots\dots\dots (15)$$

$$Z_3 = \frac{2 Z' Z'' Z'''}{-Z' Z'' + Z'' Z''' + Z''' Z'} = \frac{2}{\frac{1}{Z'} + \frac{1}{Z''} - \frac{1}{Z'''}} \dots\dots\dots (16)$$

The method outlined gives each component of impedance detecting any unbalance. At perfect balance, $Z_1 = Z_3$, $Z' = Z'''$.

$$Z_1 = Z_3 = 2 Z'' \dots\dots\dots (14a)$$

$$Z_2 = \frac{2 Z' Z''}{2 Z'' - Z'} = \frac{1}{\frac{1}{Z'} - \frac{1}{2 Z''}} \dots\dots\dots (15a)$$

When the balanced line is fed from a balanced source, the effective input impedance is given by

$$Z_{AB} = \frac{2 Z_1 Z_2}{2 Z_1 + Z_2} = \frac{4 Z' Z''}{4 Z'' - Z'} \dots\dots\dots (17)$$



WAXES AND COMPOUNDS FOR INSULATION and WATERPROOFING of ELECTRICAL and RADIO COMPONENTS

● such as transformers, coils, power packs, pot heads, sockets, wiring devices, wet and dry batteries, etc. Also WAX SATURATORS for braided wire and tape and WAXES for radio parts. The facilities of our laboratories are at your disposal to help solve your problems.

Zophar MILLS, Inc.
FOUNDED 1846
120-26th ST., BROOKLYN, N. Y.



Another FINCH First! World's Fastest Facsimile System

- Sensational new equipment now produces full size five-column tabloid page at rate of twenty square inches per minute or eight complete pages per hour!
- Transmits press, drawings, photos, advertisements—all of the features of a modern newspaper. Uses a dry electro-sensitive paper issuing copy black-on-white in fine detail and in original size.
- Finch Facsimile is self-synchronizing under all conditions of service and can be operated from any source of electric power, AC or DC, and from local batteries.
- Fifteen of the nation's major radio broadcasting stations, U. S. and foreign governments, now use Finch Facsimile in their daily operations.

GET FULL ENGINEERING AND
COMMERCIAL DATA FROM

FINCH
TELECOMMUNICATIONS
LABORATORIES Inc.

1819 BROADWAY NEW YORK, N. Y.

The value of Z_{AB} obtained represents the input impedance seen from the source. It should be measured once with the far end of the line open and once with it closed if it is desired to compute the characteristic impedance and propagation constant by the usual method. No grounds should be made to the line at any point other than the input when making measurements.

Routine measurements on a terminated line can also be made by a method which is considerably simpler than that outlined but which is much more restricted in scope. This method consists in connecting between the *unknown* bridge terminals and the balanced line a shielded transformer having an unbalanced primary and a balanced secondary. For maximum flexibility the turns ratio should be so chosen that the bridge can be balanced at a resistance setting of about 50 ohms when the transformer secondary is terminated in a resistance equal to the characteristic impedance of the line. To calibrate the bridge, various known impedances are then connected across the transformer secondary and the corresponding bridge readings are noted. Through the resulting curves the values of balanced impedances can be determined from the bridge settings.

BIBLIOGRAPHY

- (1) William A. Fitch and William S. Duttera, "Measurement of Broadcast Coverage and Antenna Performance," Part II, *RCA Review*, Vol. 3, No. 3, p. 340, Jan., 1939.
- (2) E. A. Laport, "Some Notes on the Influence of Stray Capacitance Upon the Accuracy of Antenna Resistance Measurements," *Proc. I.R.E.*, Vol. 22, No. 5, p. 657, May, 1934.
- (3) D. B. Sinclair, "Broadcast Antenna Measurements with the R-F Bridge," *General Radio Experimenter*, Vol 12, No. 9, p. 5, Feb., 1938.



MICROVOLTS, INC.

Microvolts, Inc., is a new company that has been formed by a group of Boonton, N. J., engineers for the purpose of developing and manufacturing a line of precision radio-frequency testing and measuring instruments, with particular emphasis on the ultra-high-frequency field. The engineers include C. J. Franks, Jerry Minter, J. G. Haas, and J. M. VanBeuren. New models will be announced to the trade shortly.

TELEVISION BOOK

"Practical Television by RCA," a 40-page book outlining the RCA television system, particularly receiving-circuit designs, antenna installation, and reception, has been published by the Service Division of the RCA Manufacturing Company. "Practical Television," which seeks to dispel some of the mystery of television in a practical fashion, includes 62 illustrations (38 of them RCA-NBC television test patterns for the most part never before published), and is printed on heavy-coated paper and easy-to-read type. The book is being supplied by RCA distributors, and bears a printed price of 25c.

● You and your associates can obtain a year's subscription to **COMMUNICATIONS** (12 issues) for only \$1.00 each by using the Group Subscription Plan.

A regular yearly subscription to **COMMUNICATIONS** costs \$2.00 — but when four or more men sign up at one time, each one is entitled to the half-price rate. (Foreign subscribers on the "G-S-P" only pay \$2.00 each).

COMMUNICATIONS

19 E. 47th St., N. Y. C.

Please enter annual subscriptions (12 issues) for each of the undersigned for which payment is enclosed at the rate of \$1.00 each. (This rate applies only on 4 or more subscriptions when occupations are given.) Foreign Subscriptions are \$2.00 each.

Name

Street

City-State

Occupation or title

Employed by

Nature of business

(State if Manufacturer, Broadcast Station, etc.)

Product

Name

Street

City-State

Occupation or title

Employed by

Nature of business

(State if Manufacturer, Broadcast Station, etc.)

Product

Name

Street

City-State

Occupation or title

Employed by

Nature of business

(State if Manufacturer, Broadcast Station, etc.)

Product

Name

Street

City-State

Occupation or title

Employed by

Nature of business

(State if Manufacturer, Broadcast Station, etc.)

Product

POLYRHETOR

(Continued from page 11)

chronous point after the latter's controls are set for re-starting. Light signals at the operators position indicate correct synchronous operation and any departure is immediately flashed on an indicating board showing whether the sound system or the conveyor is at fault.

TUBE CHARACTERISTICS CHART

The seventh edition of the Tung-Sol radio tubes characteristic chart is now available. Considerable information is contained in this booklet which may be obtained by writing to the Tung-Sol Lamp Works Inc., Newark, N. J.

HOWARD B. JONES BULLETIN

Howard B. Jones has recently issued a new revised bulletin covering electrical connecting devices. This 36-page booklet may be secured by writing to the above organization at 2300 Wabansia Ave., Chicago, Ill.

NEW SPRAGUE FACTORY

The recent purchase by the Sprague Specialties Company of a second set of factory buildings in North Adams, Mass., results in almost doubling the floor space now available in that city for the manufacture of condensers and resistors. The new plant consists of an office building, three separate manufacturing buildings ranging from two to four stories high, a power house and three warehouses.

BAKELITE BOOKLET

Bakelite Corporation, 247 Park Ave., New York City, have just issued a booklet entitled "New Paths to Profits." It is said to be a businessman's guide to modern plastic materials. Copies are available from the above organization.

THORDARSON SALES MANAGER

Thordarson announces the appointment of W. S. Hartford as General Sales Manager. Mr. Hartford's experience in the industry dates from 1927 when he joined the radio sales division of Kellogg Switchboard in a sales promotional capacity. Now in his sixth year with Thordarson, he has made a close study of merchandising problems of mutual interest to distributor and manufacturer and is fully acquainted with Thordarson products and their distribution.

LINK BULLETINS

Fred M. Link, 15 East 26th St., New York City, has recently made available a number of bulletins giving descriptions and specifications of their line of police-radio equipment, frequency monitors and signal generators. Copies may be secured from the above organization.

FACSIMILE EQUIPMENT

W. G. H. Finch, President of the Finch Telecommunications Laboratories, Inc., New York City, has announced that WOKO in Albany, N. Y., has concluded an agreement for use of Finch facsimile apparatus. WOKO will go on the air just as soon as it receives its FCC facsimile grant. Other broadcasters now using Finch facsimile equipment are WLW, WOR, WGN, WSM, WHO, WWJ, KSTP, WHK—WCLE, WSAI, WGH, and W2XBF.

ALL YOU'VE
EVER ASKED FOR
in a sound recorder
—YOU'LL FIND in
the **NEW PRESTO**
MODEL Y

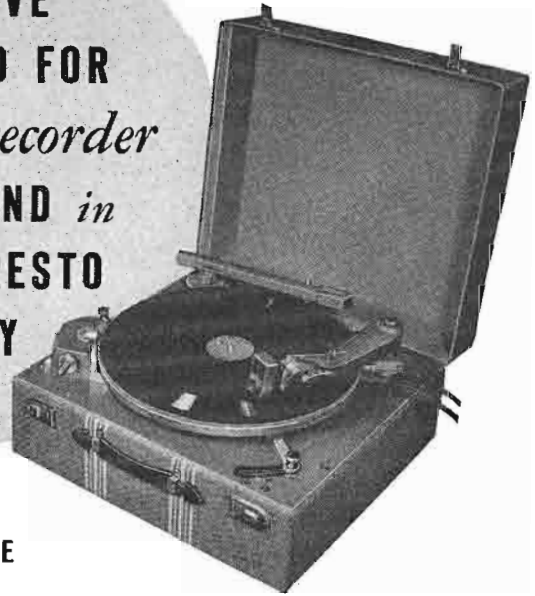

NEW 16" TURNTABLE

Completely new rim drive mechanism. Uses no idler wheels. Changes from 78 to 33½ rpm. instantaneously.

Shift a lever—cut outside-in or inside-out.

New cutter feed mechanism. Makes eccentric trip groove at finish of record . . . makes starting and runout spiral grooves . . . cuts 112 lines per inch. Presto high fidelity cutting head. Range 50 to 6500 cycles.

Cuts record up to 17¼" size.



NEW RECORDING AMPLIFIER

Output ten watts—gain 125 db.

Equipped with two-microphone mixer, high and low frequency equalizers, playback volume control, volume indicator, and selector switch for recording and playing records and for public address operation.

LIGHTEST 16" RECORDER ON THE MARKET

Turntable mounts in one case weighing 44 lbs. Amplifier and loudspeaker combine in second case weighing 47 lbs.

PRICE COMPLETE EXCEPT
FOR MICROPHONE AND
STAND . . \$595.00



Write for descriptive folder giving complete data

PRESTO RECORDING CORPORATION
242 West 55th Street, New York, N. Y.

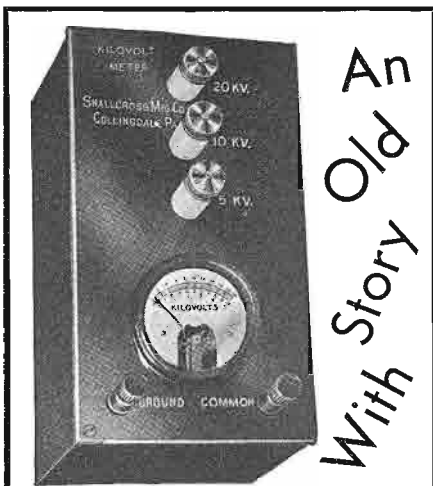

An
Old
Story
With

SHALLCROSS

High voltage measurement—now such a necessary part of television design—is an old story to the Shallcross Manufacturing Company.

The Shallcross line of kilovoltmeters—ranging from one to two hundred kilovolts—have been used for years by other branches of the electrical industry. The dependability, accuracy and fair price of these instruments has been proved.

Let Shallcross answer your high voltage measurement problems.

Write for Bulletin 700-SF

SHALLCROSS MFG. CO.
COLLINGDALE, PA.

Be Sure
It's *Fairchild* ...

1. The Fairchild F-26-2 Recorder, for example, paces the industry. Here's how:
 16" Turntable • Two speeds—78 and 33½ r.p.m. • Direct synchronous drive at 33½ r.p.m. assures split-second timing. • Crystal cutter head of new design • Improved recording amplifier.
2. Fairchild tone fidelity and distortion-free range have amazed experts. And—our job is not done until you get maximum results ...



BAIRD LARGE-SCREEN PROJECTION TELEVISION

THE Baird Television Corporation offered its second demonstration in America of large-screen projection television on June 20, 1939, in New York City. One or more such demonstrations will be given each week, and, since the size of the auditorium is limited in capacity, admission will be by invitation only.

The demonstration witnessed by your television reporter left no doubt in his mind that large-screen television is a practical reality, and further, that television, particularly for spot news, will provide a valuable supplement to present cinema programs.

Considering the demonstration as a whole the quality of the picture—in this case, an NBC transmission of *The Pirates of Penzance*—was remarkable. Some minor defects were, however, noticeable, the principal one being a peculiar elongation of noses. In general, it might be said that there was a tendency toward an elongation in the vertical direction and a contraction, but to a lesser degree, in the horizontal direction. Streaky effects were also occasionally observable. The stroboscopic effect when the conductor waved his baton was rather surprising. In what proportion these defects were due to the transmission end as opposed to the receiving end we are not in a position to state. These defects, however, were of such minor nature that it appears quite likely that they will soon be eliminated.

As shown in the illustration, the projection tube is of the direct-viewing type, that

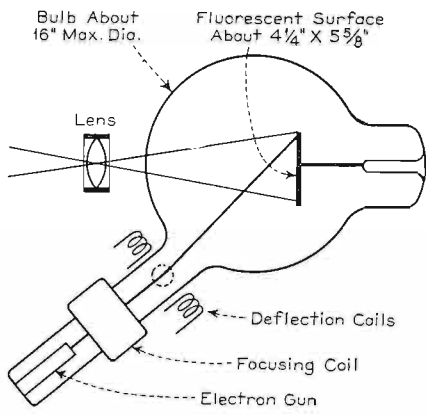

is, the image is taken from the same side of the fluorescent screen that is scanned. In appearance this tube resembles the iconoscope except that a fluorescent surface replaces the photoelectric mosaic. This fluorescent surface is of special composition and is approximately 4½ by 5½ inches in size. The diameter of the bulb in which this fluorescent plate is enclosed is quite large, about 16 inches, partly in order to obtain adequate heat dissipation.

The image appearing upon the fluorescent surface is projected by means of a lens upon the viewing screen. The viewing screen brought from England was about 15 by 20 feet, but was found to be too large to fit into the auditorium, in consequence of which a 9 by 15 foot screen is being used.

The Baird Company also showed a home television receiver capable of receiving American television programs and which employed approximately one-half the number of tubes currently used in American television receivers. As no further television programs were available this receiver was not seen in operation.—R. L.



Those who make an art of living depend on this world famed hotel as the very embodiment of gracious service, true refinement and dignified hospitality.

- Under the same Management as
- The Gotham
NEW YORK CITY
 - The Drake
CHICAGO
 - The Evanshire
EVANSTON, ILL.
 - The Town House
LOS ANGELES
- A. S. Kirkeby
Managing Director

The Blackstone
Michigan Avenue • CHICAGO

WHEN YOU CHANGE YOUR ADDRESS

Be sure to notify the Subscription Department of COMMUNICATIONS at 19 E. Forty-seventh St., New York City, giving the old as well as the new address, and do this at least four weeks in advance. The Post Office Department does not forward magazines unless you pay additional postage, and we cannot duplicate copies mailed to the old address. We ask your cooperation.

BOOK REVIEWS

STANDARDS ON RECEIVERS 1938, published by The Institute of Radio Engineers, Inc., 330 West 42 Street, New York City, 1938, 58 pages, paper covers, price 50 cents.

The first section of this book is devoted to the standardized definitions of terms pertaining to amplification, modulations, rectification, circuits, circuit elements, receivers, and auxiliary equipment. This is followed by two pages of graphical symbols.

The major portion of the text concerns itself with methods of testing broadcast radio receivers, both as regards the requirements and characteristics of the testing apparatus as well as the actual test procedures.

This book is recommended to all communication engineers. R. L.

STANDARDS ON TRANSMITTERS AND ANTENNAS 1938, published by The Institute of Radio Engineers, Inc., 330 West 42 Street, New York City, 1938, 42 pages, paper covers, price 50 cents.

This is another of the excellent series of booklets devoted to I.R.E. standards, this volume being devoted to transmitters and antennas.

The first fourteen pages give the standardized definitions of terms pertaining to transmitters and antennas. This is followed by two pages of graphical symbols.

Nine pages are devoted to methods of testing transmitters including such topics as power rating, spurious radiations, frequency stability, operational stability, and amplitude modulation.

There then follows thirteen pages on methods of testing single-unit and multi-unit antennas and a discussion on the propagation of radio waves.

This book is a recommended addition to the radio engineer's library. R. L.

RADIO'S MASTER ENCYCLOPEDIA, 1939 edition, published by the United Catalog Publishers, 258 Broadway, New York City, 1938, 670 pages, price \$2.50.

This book is somewhat misnamed, since in reality it is a master catalog and not an encyclopedia. However, it does contain a comprehensive listing and description of the products of practically all important manufacturers in the industry. Illustrations, technical information and prices are provided. Prices, in every case, are listed. Inconspicuously, at the bottom of each page the discount is indicated in code.

A classified directory at the beginning of the volume gives the names and addresses of the various manufacturers of parts and accessories, alphabetically by products. This should prove valuable as an exhaustive buyer's guide.

Indexing and cross indexing is exceptionally good. R. G. H.

We have received a copy of *SANDS, CLAYS, AND MINERALS* (Published by A. L. Curtis, Westmoor Laboratory, P. O. Box 61, Chatteris, England at 3/6 per copy). This periodical deals mainly with the geographical distribution, the mining, and the practical applications of sands, clays, and particularly minerals. The scope of the articles is broader than the title of the magazine would indicate, for, in the particular issue at hand, there appear essays on such widely diversified topics as: "Selection of Coal for Industrial Purposes," "Early Technical Balances," "Reparation of Historical Buildings," and "Rubber Fillers."

D. B.

the new DAVEN Type No. 910 VOLUME LEVEL INDICATOR

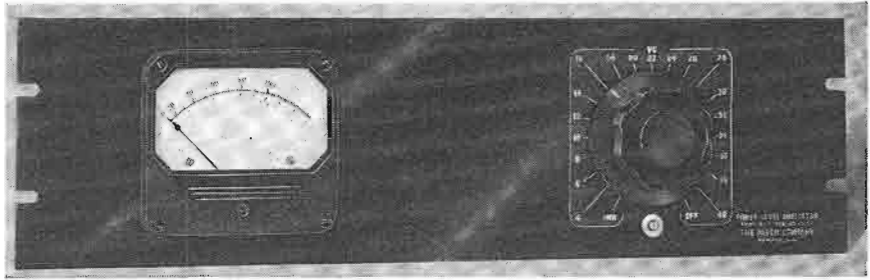

It is designed to indicate audio levels in broadcasting, sound recording, and allied fields where precise monitoring is important. The Type 910 unit is completely self-contained, requiring no batteries or external power supply. The indicator is sensitive to low power levels, rugged and dependable.

The indicator used in this panel is the new WESTON Type 30 meter, the dynamic characteristics of which have been approved by BELL TELEPHONE LABORATORIES, N.B.C. and COLUMBIA Engineers. The indicator reads in percent voltage and VU. The "VU" is defined as being numerically equal to the number of DB above 1 mw. reference level into 600 ohms.

Two meter controls are provided, one a small decade with screwdriver adjustment for zero level setting of the meter pointer; the other a constant impedance "T" type network for extending the range of the instrument in steps of 2 DB.

Because of the length of the meter scale, small differences in pointer indications are easily noticed. For this reason the screwdriver type vernier is provided. All V. I. meters can thus be adjusted to the same scale reading. This is particularly convenient in complex installations where several V. I. meters must be read by one operator, or in coordinating the various meters at different points in a network.

SPECIFICATIONS

- ★ INPUT IMPEDANCE: 7500 ohms constant on all steps of meter range switch except on the 1 mw. calibration step.
- ★ POWER LEVEL-RANGES: Standard 1 mw. at 600 ohms reference. See table below.
- ★ FREQUENCY RANGE: Less than 0.2 Db. variation up to 10,000 cycles.
- ★ SCALE READING: Meter calibrated —20 to 3 VU and 0 to 100%. Type "A" Scale, for sound level work is marked in VU on the upper scale; Type "B" Scale for broadcasting work is marked in percent on the upper scale.
- ★ INDICATING METER: Copper-oxide-type adjusted for deliberate pointer action. Large clearly marked scale.
- ★ METER RANGE CONTROL: Heavy duty "T" network. Input impedance 7500 ohms; Output impedance 3900 ohms. Attenuation variable in steps of 2 VU.
- ★ METER ADJUSTMENT CONTROL: Miniature step-by-step decade type unit. Designed for fine adjustment of the zero level reading over a range of ± 0.5 VU.
- ★ MOUNTING: Standard relay rack Mounting Aluminum Panel 5¼ x 19".
- ★ FINISH: Black dull satin finish; R. C. A. or W. E. gray.

Type No.	Range	Zero Calibration	Scale	Price
910-A	1 mw. +4 to 40 VU off	1 mw. 600 Ohms	A	\$72.50
910-B	1 mw. +4 to 40 VU off	1 mw. 600 Ohms	B	72.50
910-C	1 mw. +4 to 24 VU off	1 mw. 600 Ohms	A	67.50
910-D	1 mw. +4 to 24 VU off	1 mw. 600 Ohms	B	67.50

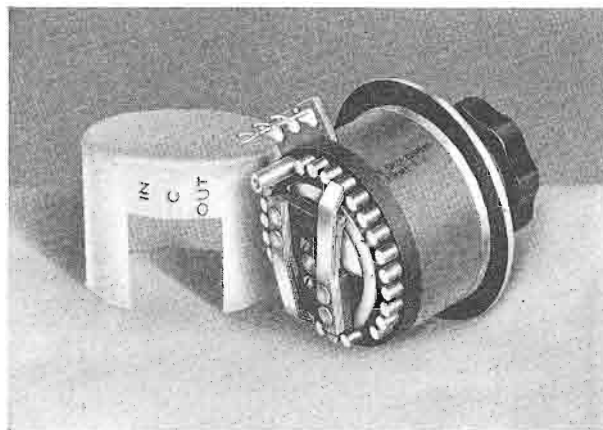

The new "T" attenuator illustrated at left is a 12 step unit. Both the 12 and 20 step attenuators are in stock for immediate delivery.

Type T-994
Price \$12.50
12 step attenuator

Type TA-1000
Price \$17.50
20 step attenuator

Round dial supplied with above attenuator

Type 991
Price \$3.00
Rheostat for calibrating meter

THE DAVEN COMPANY

158 SUMMIT STREET

NEWARK, NEW JERSEY



VETERAN WIRELESS OPERATORS ASSOCIATION NEWS



W. J. McGONIGLE, President

RCA Building, 30 Rockefeller Plaza, New York, N. Y.

H. H. PARKER, Secretary

DE FOREST DAY

REMEMBER de Forest Day at the New York World's Fair, Friday, September 22nd, 1939. We look forward to having a large out-of-town representation in New York on that day to pay tribute to one of humankind's greatest benefactors and a true wireless pioneer, Dr. Lee de Forest. Dr. de Forest will be there in person and will greet you then. Let's all get together, then, and make this a truly worthy tribute to a most deserving scientist. We will see you at the New York World's Fair on de Forest Day, September 22nd, 1939.

SEATTLE

One of our real old-time members, and a member since the inception of our Association, is our Seattle, Washington, Representative, Captain Robert Woolverton, United States Army Signal Corps, now in charge of the Army's Alaska Communication System in Seattle. (That's the Army Radiotelephone link between Seattle, Wash., and Alaska.) Captain Bob journeys back in memory to the days when one George Clark (our illustrious Past President and Historian) was south bound on the old *Lebanon*, about 1906, and talked with Bob Woolverton on the battle wagon *Kentucky*, then off the Virginia Capes. He started radio operating on the *Kentucky* in 1904, and in 1905 was the first person to design equipment for, and to actually use a high-spark frequency in radio communication—for which accomplishment he was made a Fellow of the Institute of Radio Engineers in 1915.

In 1913 he became the first Radio Supervisor for the Department of Commerce at San Francisco. Assignments that followed included assisting in the design and subsequently building the 500-kw arc stations at San Diego, Pearl Harbor, and Cavite, and during the World War, in 1918, was Army Radio Officer, 2nd United States Army in France. His wide acquaintance in the radio fraternity, made possible by his continuous activity in the radio art, includes practically all of the pioneers and others too numerous to mention.

Active, today, in his Signal Corps berth at Seattle, Washington, Captain Bob can be said to be one of the true pioneers who have contributed much to the art throughout its lifetime. Captain Bob Woolverton, we salute you—A Wireless Pioneer.

SAN FRANCISCO

We find that our San Francisco Chapter Chairman Gilson Willets has not failed to promote VVOA interests since the SF cruise in February. Among the new members signed up in that area are: E. H. Dodd, Captain U. S. N., Ret., who graduated from the Naval Academy in 1898 and among his assignments includes two years, from 1908 to 1910, at the Mare Island Navy Yard, and from 1910 to 1926 in the Communications service of the United

States Navy. Since April 15th, 1929, Captain Dodd has been engaged in an executive capacity with the Mackay Radio and Telegraph Company at San Francisco. His many friends in the radio fraternity may communicate with him at 724 Eighth Avenue, San Francisco—N. O. Gunderson, who started in the Navy in December, 1924, and served until 1927, then brass pounding for Mackay from 1929 to 1931 and since then in the Marine Department of the Mackay Company—Miguel Lopez, stationed at the A. T. & T. plant at Dixon, Calif., formerly long affiliated with us and now renewing his membership.

MONUMENT

On Memorial Day, May 30th, 1939, a wreath of poppies was placed on the Wireless Operators' Monument in Battery

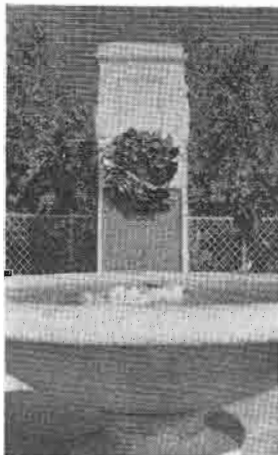

Park, New York, by our President. Our good member, W. Steadman, placed a cluster of fresh flowers in the font which stands in front of the Monument. The picture shown was taken that day.

BOSTON

An interesting communication from Bart McCarthy, Secretary-Treasurer of the Boston Chapter re recent doings in those parts. Bart states that so soon as they have another function there he will furnish the details for inclusion in this page. BM is doing a good job of keeping the Boston group VVOA minded.

AWARD

On a recent visit to the office of Geo. P. Smith, Jr., recently made "Czar" of the amusement area of the New York World's Fair, 1939 (according to a report in the World Telegram), we noticed a plaque for distinguished service awarded to Mr. Smith in 1933 by the National Showmen's Association. GPS, by the way, was Chief

Radioman of the flagship of the United States Fleet on the trip around the world in 1908. He is not only a veteran radioman, but, as the newspaper article put it, "the veteran showman, George P. Smith, Jr." Our best wishes for a successful Fair, GPS.

IN MEMORIAM

We learned with deep regret of the recent deaths of two of our members. Steve Kovacs, long a member of our Association and a loyal supporter of our activities, died in the Key West Marine Hospital after a short illness. Steve was liked by all who knew him and his death is a real blow to us all. We mourn his loss and extend our sincerest condolences to his family.

Clinton Gluck, an old-time Navy radio man, retired but recently employed at the WJZ transmitter, died recently after a prolonged illness in the Naval Hospital in Brooklyn. His funeral service was attended by our President, Fred McDermott, a friend of the old Navy days, and Wm. Fallon, an associate of Mr. McDermott's. Clinton was a fine fellow and a good radioman and his loss will be felt by all who knew him. Our deep sympathies to his family.

TRIBUTE

A rather belated tribute to A. F. Wallis, Vice-President 1938, H. H. Parker, Secretary then and now, and W. C. Simon, Treasurer then and now, for their splendid efforts in furthering the work of the Association. Such cooperation on the part of our officers and members assures the continued success and growth of our organization. They did a noble job and we acknowledge it here. Your cooperation in sending in your dues promptly, supplying interesting items for this page and promoting the interests of our Association generally is deeply appreciated. Continue it and success is ours.

NEW MEMBERS

Among new members recently initiated are: Fred J. Gommo, who started in radio operating for RCA in August, 1927, and is now with the United Fruit Company; Wilbur T. Marshall, who served aboard the *Finland* and *Kroonland* in 1926 and is now in the Ship Telephone Service of the New York Telephone Company at the New York station.

CLEVELAND

We received an interesting letter from Ralph Worden, News Editor of radio station WGAR in Cleveland regarding the possibilities of organizing a real up and going chapter there among the many old-timers, residents of that city. Our fullest cooperation to you, Ralph, and all aboard for Cleveland.

BEER PARTY

At the recent Smoker held in New York a good time was had by all. All the beer one could drink, coupled with a substantial meal and the usual corn cobs and 'baccy and the endless stories of past experiences, resulted in a full evening of enjoyment. Among those present were: "Bill" Simon, our Treasurer; H. H. Parker, our energetic and hard-working Secretary; R. H. Pheysey of the Unifruitco and a faithful attendant at all our functions; Carl O. Petersen, our 1938 Gold Medal of Valor recipient, accompanied by Mr. Griswold and several other members of the Paramount News staff; our President; O. W. Penney and Mr. Garcia of the staff of WMCA, one of the larger metropolitan stations; Mr. Mong, at present a civil engineer with a local oil company, but formerly a radio operator with the United Fruit Company; W. Steadman, one of our most enthusiastic VWOA boosters who is always there when we have a meeting or function, and some few others.

PERSONALS

Our heartiest congratulations to the Messrs. Beakes and Nicholas, both Life Members of our Association, on their recent elevation to the top position in their companies. Mr. Beakes recently assumed the position of President of the Tropical Radio and Telegraph Company after a lifetime of service in the field of radio. Mr. E. A. Nicholas, formerly in charge of the License division of RCA, was elevated to the presidency of the Farnsworth Television Corporation. A biographical sketch of each of them will appear in an early issue. . . . Frank L. Velten sends in the necessary. . . . How is Ebby getting along down Floridy way? The warm weather probably discourages letter writing. . . . "Bill" McGonigle recently received a new copy of the FCC's First Class Radiotelegraph License with First Class Radio Telephone Endorsement and in addition holds a Class A Amateur license. Yes, he took and passed the 25-word straight language and 20-word cipher code test. It was a bit tough, though. . . . A. F. Wallis recently left New York to assume new duties for the Mackay Company at New Orleans. We look for a sharp upturn in VWOA activities in the Gulf region. AF is a past Vice-President and is at present a Director besides being a quite successful sales manager. Let's hear from you often, "Steve."

• • •

FERRIS BULLETIN

The Model 33 Radio-Frequency Calibrator is described in a bulletin which may be obtained from the Ferris Instrument Corp., Boonton, N. J. This Calibrator is a small, portable unit which supplies standard frequencies.

JANETTE BULLETIN

Bulletin 14-25 has recently been issued by the Janette Manufacturing Co., 556-558 W. Monroe St., Chicago, Ill. This bulletin gives considerable information on dynamotors. Write to the above company.

GENERAL RADIO BULLETIN

"Variac Transformers for Voltage Control" is the title of a bulletin made available by the General Radio Co., 30 State Street, Cambridge, Mass. Descriptions and specifications are given.

RCA BULLETINS

Several new bulletins have been made available by RCA Manufacturing Co., Inc., Camden, N. J. One bulletin deals with measuring equipment for industrial, laboratory, radio station, and school and university uses; another with speech-input equipments for single and two-studio installations; the third describes the AVA-41 aircraft antenna system.

"SOUND ADVANCES"

"Sound Advances" is the title of a bulletin that is published by Sound Apparatus Co., 150 W. 46th St., New York City. The latest issue of this bulletin contains some very interesting information on a new magnetic and a new crystal recording head. Copies may be secured from the above organization.

PHOTOSWITCH BULLETINS

A number of new bulletins are now available from Photoswitch, Inc. This literature is devoted to the application and description of a photoelectric cell control for industrial uses. To secure the literature write to the above organization at 21 Chestnut St., Cambridge, Mass.

PACENT BULLETIN

The Type 9-R high-fidelity remote-control radio receiver is described in a bulletin now available from the Pacent Engineering Corp., 79 Madison Ave., New York City. Write to the above organization for Bulletin 103.

DUPLEX RECORDING BULLETIN

The Model A 16 Duplex Recorder is described in a bulletin available from Duplex Recording Devices Co., 514 W. 36th St., New York City. Prices and specifications are given.

AMERICAN MICROPHONE BULLETIN

American Microphone Co., Inc., 1915 S. Western Ave., Los Angeles, Calif., recently issued Special Bulletin No. 33, describing their Model D8T moving-coil dynamic microphone and the C6 crystal microphone. The above organization will send the bulletin free on request.

EPCO BULLETINS

A number of bulletins have just been made available by Electronic Products Co., St. Charles, Illinois, describing their line of photoelectric control apparatus and industrial applications. Copies may be secured from the above organization.

ALTMAYER APPOINTMENT

John Altmayer, Advertising Manager of The Brush Development Company, Cleveland, for more than two years, has just joined the advertising agency of Gregory and Bolton, Inc., with offices in Cleveland and Youngstown, Ohio, in the capacity of Account Executive and Technical Consultant.

TELEVISION MEETING

The Hollywood Television Society holds meetings weekly on Tuesdays at 7:30 P. M., at the recreation building of the Plummer Park, Hollywood. Entrances to the park are at 7377 Santa Monica Blvd., and 1156 N. Vista St. The program from the Don Lee television station, W6XAO, is received on receivers built by the membership. Technical talks follow the demonstration at 8:30 P. M.

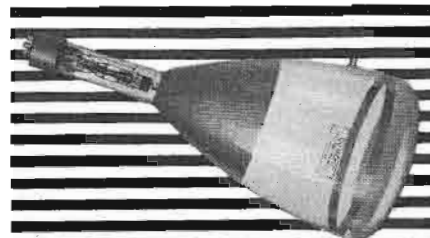

A Versatile INDICATOR

As an oscillograph, the cathode-ray tube provides the only available indicator which may be applied effectively to any problem, free from all inertia effects, and capable of plotting a visual curve of one quantity as a function of any other quantity.

Having pioneered the development of commercialized cathode-ray equipment, we shall gladly share this experience in its application to your specific problem.

ALLEN B. DUMONT
LABORATORIES, Inc.
PASSAIC • NEW JERSEY

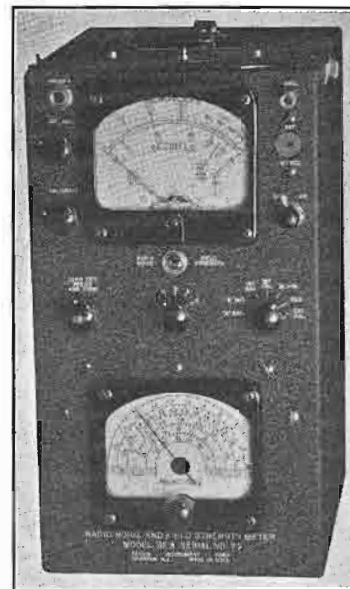

Ferris Model 32 Radio Noise and Field Strength Meter

A Universal Direct Reading Microvoltmeter for Measuring all Types of Radio Noise and Carrier Fields.

Coverage 150-350 and 550-20,000 kilocycles—direct reading, logarithmic scale on output meter—built in calibrating generator.

Send for bulletin E 32 for complete details.

Circulars on Signal Generators are available on request.

FERRIS INSTRUMENT CORP.
Boonton, New Jersey

Fluorescent Materials

SILICATES and Tungstates, in all colors in the spectrum, are available for cathode ray tube applications.

TUNGSTEN — MOLYBDENUM — KULGRID LEAD-IN WIRES

Leading tube manufacturers are well acquainted with the life-long dependability and production accuracy of Callite Tungsten—Molybdenum and Kulgrid lead-in wires. Don't accept inferior substitutes. Depend on Callite quality products for maximum production efficiency.

IN ALL COLORS IN THE SPECTRUM FOR TELEVISION APPLICATION . . .



Call on Callite engineers for detailed information on fluorescent materials, lead-in wires and contact points.

CALLITE PRODUCTS DIVISION
 EISLER ELECTRIC CORP. • 542 39th ST. • UNION CITY, N. J.

For PROFESSIONAL USE

RECOTON

Playback & Transcription NEEDLES

Steel Cutting NEEDLES

Sapphire Cutting & Playback NEEDLES

Write for Complete Descriptive Literature

RECOTON Corporation
 178 Prince St., New York

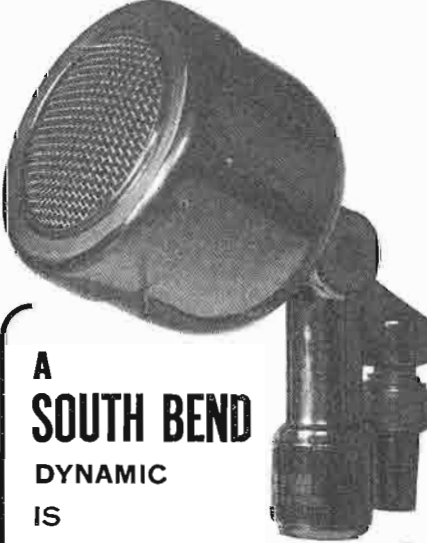

A SOUTH BEND DYNAMIC IS REALLY GOOD

A WIDE RANGE microphone of greater output. A rugged, sensitive instrument of simple beauty to grace any sound set-up.

MODEL D3—with cable \$25

SOUTH BEND MICROPHONE CO.
 1720 Mishawaka Avenue
 South Bend - - - Indiana

NEW COMPANY

Following a recent reorganization of its parent company, Air Devices Corp., Connecticut Telephone and Electric Corporation, Meriden, Conn., is announcing the appointment of a new staff of executives, including a new president. The new organization will be headed by Harold W. Harwell, former Vice-President and General Manager of Cinaudagraph Corporation, Stamford, Conn., as President. Charles A. Cunnene, who has been connected with the company since 1922, will serve as Secretary-Treasurer. The sales activities of the company will be directed by Frank Holmstrom, newly-appointed Vice-President and General Sales Manager. Joseph A. Sullivan and George Lundquist, both long-time members of Connecticut's sales staff, have been appointed assistants to Mr. Holmstrom. Sales promotion and advertising will be under the direction of another new staff member, Charles H. Gillette, who for the past five years served in a similar capacity for American Bosch Corporation, Springfield, Mass. Established in 1894, Connecticut Telephone and Electric Corporation has been engaged in the development and manufacture of communication and signal systems. The new organization is planning considerable expansion in this field.

BLILEY BULLETIN

Bliley Electric Co., Erie, Pa., have just issued a bulletin that gives rather complete information on a dual-frequency crystal calibrator. Copies may be secured from the above organization. Write for Engineering Bulletin E-7.

LICENSE AGREEMENT

Announcement was made from the Inglewood, Calif., factory of the Universal Microphone Co., as of June 1, that all microphones manufactured by the firm have been licensed by Western Electric, ERPI and A. T. and T. The contractual agreement is a retroactive one and covers this phase of the organization's widespread activities from the date of its establishment eleven years ago. The license agreement is specifically for the firm's microphone division, which engages in the manufacture and distribution of microphones, stands and accessories. But it also concerns the recording division, which manufactures and distributes various types of recorders, blank records and accessories, so far as it relates to microphones used for such machines.

At the Parts Show. Left to right: I. A. Mitchell, UTC, and Sam Harris, Amperex.



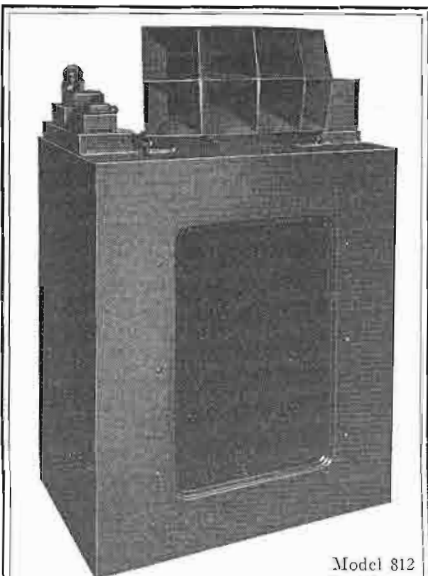

Model 812

ICONIC THEATRE QUALITY SPEAKER SYSTEMS

Broadcast engineers will like the Iconic because, whether in monitor or audition room, each voice and instrument is heard in its true natural tones. Operators of small theatres and school auditoriums will like the theatre quality with which ICONIC meets their every requirement. For full information about the Iconic System, sound reproducers, theatre systems, or speakers see your dealer or write

LANSING MANUFACTURING CO.
6900 McKinley Ave. Los Angeles, Calif.

LAMINATIONS for Output TRANSFORMERS of Highest Permeability

Standard stocks in a wide range of sizes for Audio, Choke, Output and Power Transformers. Write for dimension sheets.

permanent MAGNETS

ALNICO (Cast or Sintered)

COBALT-CHROME-TUNGSTEN

Cast, formed or stamped permanent magnets for all purposes. Engineering cooperation backed by 38 years experience in magnet making.

TOOLS » DIES » STAMPINGS
HEAT TREATING

Thomas & Skinner
Steel Products Co.

1113 E. 23rd St. Indianapolis, Ind.



Taken at the National Radio Parts Trade Show. Left to right: Ed. Hughes, Doug. Smith and John Allen.

FAST APPROVAL OF RECEIVERS

Twenty-four hour service on radio receivers has been inaugurated recently by Underwriters' Laboratories to permit the examination, test and inspection of new designs as rapidly as manufacturers can produce them. Production in the radio industry makes this special service desirable. Frequently less than two weeks elapse between the time a manufacturer receives an order for a lot of receivers of a special design and the day the sets are delivered. Frequently no more of these sets are made after the order is completed, and none is kept in stock at the factory. To keep pace with this fast production schedule in approving receivers for safety, Underwriters' Laboratories' engineers now consult with manufacturers, examine and check engineering department drawings and parts for the new sets and render a tentative opinion immediately.

CROWE BULLETIN

Crowe Name Plate & Manufacturing Co., 3701 Ravenswood Ave., Chicago, Ill., have just issued an interesting and attractive bulletin giving considerable data on Crowe parts for amateurs and for manufacturers of sound equipment, transmitters, testing instruments and similar devices. Write to the above company for Bulletin No. 225.

CORNELL-DUBILIER CATALOG

An 8-page, two-color catalog describing the line of C-D Capacitor Analyzer, Bridge and Decades has been released to the trade. Copies of catalog No. 167-A listing all the advantages of the Analyzer, Bridge and Decades free on request. Inquiries should be addressed to the Cornell-Dubilier Electric Corporation, South Plainfield, New Jersey.

RCA ACQUIRES RIDER INSTRUMENTS

The manufacturing and sales rights to the Rider "Chanalyst" and the Rider "VoltOhmyst," introduced about a year ago by Service Instruments, Inc., have been acquired by the RCA Manufacturing Company, according to a joint announcement by John F. Rider, President of Service Instruments, and L. A. Goodwin, Jr., RCA Accessories and Test Equipment Sales Manager. At the same time, RCA announced a new policy of "Minimized Obsolescence" in the production of service test equipment.

**DESTINED
to become a
LANDMARK**

Lingo structures erected 40 years ago are still giving uninterrupted service . . .

LINGO Vertical Tubular Steel Radiators are constructed and erected with an "eye to the future." . . . For 42 years LINGO has enjoyed an unequalled record of stability, even in the most notorious hurricane belts. LINGO "tube" Radiators are constructed of full-weight copper-bearing seamless steel tubing, and are not to be confused with other light-weight tubular or structural steel towers. This extra assurance of stability is only one of the many plus advantages that include a new peak efficient antenna performance and if you're "price minded" that is only another reason why you should know more about LINGO.

Write for
Descriptive Folder

Contains complete technical data and recommendations. In your request, please state location, power and frequency of station.

**JOHN E. LINGO
& SON, INC.**
Dept. C-7, Camden, N. J.

LINGO
VERTICAL
TUBULAR STEEL
RADIATORS

THE MARKET PLACE

NEW PRODUCTS FOR THE COMMUNICATIONS FIELD

REMOTE AMPLIFIER

The Collins 12Y remote amplifier is shown in the accompanying illustration. This unit is said to combine small size and light weight with high-quality program amplification. One high-fidelity channel is incorporated which operates from a low-level velocity, dynamic or other self-generating microphone. A universal input transformer matches all commercial type microphones, it is said. A single headphone jack connected across the output terminals permits program monitoring as well as talk-back from the studio. The gain control can be supplied in the variable type as illustrated or slotted for adjustment with a screwdriver. Literature may be secured from *Collins Radio Co.*, Cedar Rapids, Iowa.—COMMUNICATIONS.



Above: Collins remote amplifier.

Below: Aerovox condensers.

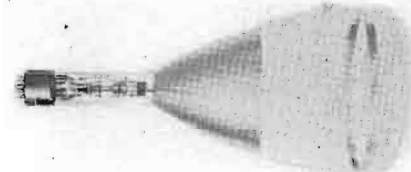

Above: DuMont cathode-ray tube.

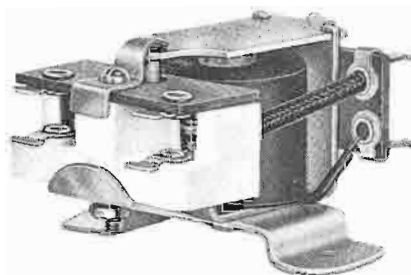

Above: Allied Control relay.

Below: Ohmite tap switches.

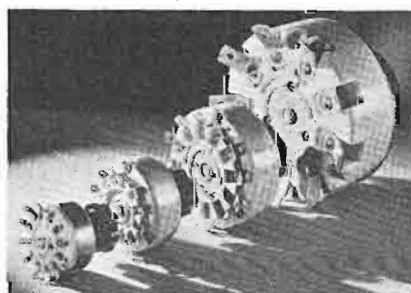

PAPER-WOUND CONDENSERS

To meet the demand for paper-wound replacements for metal-can and cardboard-case dry electrolytics, two new condensers are announced by Aerovox. The PWC series, matching in size and shape the dry electrolytic metal-can condensers, is available in three types replacing the 4-600, 8-600 and 8-8-600 electrolytics, with actual capacities of 2.0, 2.75, and 1.75-1.75 mfd, respectively. The PWP series matches the cardboard-case dry electrolytics of 4-600, 8-600 and 8-8-600, with actual capacities of 2.0, 3.0, and 2.75-2.75 mfd. These paper replacement units have low power factor and leakage. No polarity need be observed. *Aerovox Corporation*, New Bedford, Mass.—COMMUNICATIONS.

NEW TUBES

Preliminary technical information has been released on four new RCA tubes recently announced to radio equipment manufacturers, as follows: RCA-6J7-GT triple-grid detector amplifier, RCA-6K6-GT power amplifier pentode, RCA-12J7-GT triple-grid detector amplifier, RCA-35Z5-GT high-vacuum half-wave rectifier with heater tap for pilot lamp. These four types having octal bases and tubular (T-9) bulbs, supplement types in the GT-series already announced. Ratings and characteristics of these new tubes are available from *RCA Radiotron Division, RCA Manufacturing Co., Inc.*, Harrison, N. J.—COMMUNICATIONS.

RELAY

The Allied relay shown in the accompanying illustration is designated as the type D and is intended for use in police, aircraft, and marine radio applications such as antenna transfer, filament control, dynamotor starting, alarm and signal devices. It is available in s-p-s-t, s-p-d-t, d-p-s-t and d-p-d-t. Rating up to 10 amperes at 125 volts a-c. Special contacts for dynamotor starting and ratings up to 30 amperes continuous on 6 and 12-volt batteries. Further information may be secured from *Allied Control Company, Inc.*, 227 Fulton St., New York City.—COMMUNICATIONS.

U-H-F FIELD-INTENSITY METER

A new measuring instrument has recently been developed for surveying the service range of television and other stations operating in the ultra-high-frequency spectrum of from 20 to 125 megacycles (15 to 2.4 meters wavelength). This apparatus, the ultra-high-frequency field-intensity meter, not only provides accurate indications of the strength of very short wavelength signals but enables records to be made automatically, with suitable attachments, and also provides data on the amount of noise which might interfere with television pictures. *RCA Manufacturing Co., Inc.*, Camden, N. J.—COMMUNICATIONS.

CATHODE-RAY TUBES

Two recent DuMont designs in cathode-ray tubes have been announced. First, there is the new egg-shaped blank which is said to provide several times the structural strength and hence a higher safety factor in larger tubes. The second DuMont development is the intensifier type tube, offering a direct means of lowering the cost of television sets and oscillographs of given image size. The introduction of one or two gold rings deposited on the inside wall adjacent to the screen, provides for the intensifier electrode which accelerates the electrons after deflection. *Allen B. DuMont Labs., Inc.*, 2 Main Ave., Passaic, N. J.—COMMUNICATIONS.

DIAL LIGHTS

A line of eight radio dial lights, covering practically any replacement need, has been announced to the jobbing trade by Arcturus. The following types are now available: A40, A41, A42, A44, A46, A50, A51, A55.

The dial lights are packed in handy cartons of ten lamps each. *Arcturus Radio Tube Co.* Newark, N. J.—COMMUNICATIONS.

POWER TAP SWITCHES

Three new models, in addition to the 40-ampere tap switch recently announced, now completes the series of new Ohmite all-enclosed high-amperage tap switches. These new tap switches are multi-point, load-break, non-shorting, single-pole, rotary selectors particularly designed for alternating current use. They are compact and the ceramic construction provides good insulation. There are four sizes in this series: Model 212, 10 amperes, 240 volts a-c, diameter 2 1/4". Model 312, 20 amperes, 240 volts a-c, diameter 3-5/16". Model 412, 40 amperes, 240 volts a-c, diameter 4-3/16". Model 608, 75 amperes, 240 volts a-c, diameter 6". Special tap switches with less than the maximum number of taps, special length shafts, etc., can be had on order. Tandem assemblies also available. *Ohmite Manufacturing Company*, 4835 Flournoy Street, Chicago, Ill.—COMMUNICATIONS.

"TOPHET" Resistance Wire
is to the Electric Heating
Appliance what the Tylon-
Perisphere is to the World's
Fair.

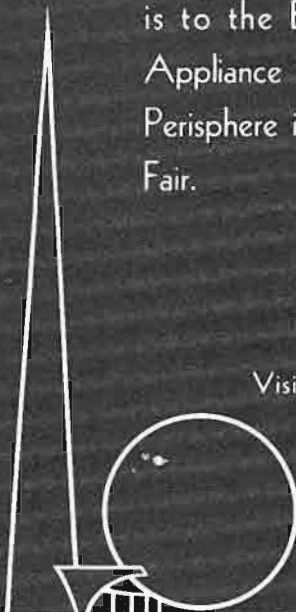

Visit our exhibit at the
World's Fair, in
the Metals Build-
ing opposite
the Tylon.

WILBUR B. DRIVER CO.
NEWARK, NEW JERSEY

DUPLEX RECORDER

The answer to the quest for constant speed

Positive Drive Sound on Disc Recording Equipment
Sync.-Drive for 16 mm hand crank camera, optional

DUPLEX RECORDING DEVICES CO.

514 WEST 36TH ST.

NEW YORK, N. Y.

TAYLOR

VULCANIZED FIBRE

PHENOL FIBRE

TAYLOR INSULATION

TAYLOR FIBRE CO., Norristown, Pa.

MR. BROADCASTER

Your transmitting tubes repaired and your
satisfaction guaranteed.

204A—\$35. 849—\$60. 228A—\$100.

Other tubes quoted on request.

Garrett W. Lewis Electronics

ROUTE 3, LOS GATOS, CALIF.

R. F. and I. F. COILS

TEXTILE COVERED AND LITZ WIRE
TRIMMER AND PADDER CONDENSERS

Write for literature—submit specifications.

EDWIN I. GUTHMAN & CO., INC.

400 SO. PEORIA STREET

CHICAGO, ILL.

Cable Address: GUTHCO

PRECISION MADE BLILEY CRYSTALS

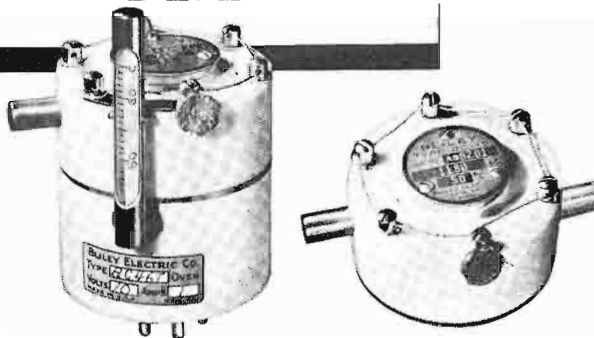

Thorough workmanship, critical inspection
tests and accurate calibration, assure the
high degree of precision and dependability
essential in all radio communication services.
Write for catalog G-10 covering Bliley crys-
tals, holders and ovens for frequencies from
20 kc. to 30 mc.

BLILEY ELECTRIC COMPANY

UNION STATION BUILDING

ERIE, PA.

MADE BETTER TO
WORK BETTER



• The combination of high tensile
strength that assures a lasting bond,
and faster, cleaner work made pos-
sible by quick-acting flux of pure water
white rosin, has given Gardiner Rosin-Core Solders an
outstanding reputation for efficiency and economy on radio
work by expert or amateur. Yet, due to modern production methods and big sales,
Gardiner Solders cost less than even ordinary kinds. Made in various alloys and
core sizes . . . and in gauges as small as 1/32 of an inch . . . in 1, 5 and 20 lb. spools.
Eastern Sales Office and Warehouse: DAVID M. KASSON & CO., 401 Broadway, N. Y.



4819 S. CAMPBELL AVENUE

CHICAGO, ILL.

We manufacture a complete line of equipment

Spot Welders, electric, from 1/4 to 500 KVA;
Transformers, special and standard types; Incandes-
cent Lamp Manufacturing Equipment; Radio Tubes,
Ex-Ray, Cathode Ray, Photo Cells, Electronic
Equipment Vacuum Pumps, etc. Tungsten Slugs,
Rod and Wire Manufacturing Equipment; General
Glass Working Machines and Burners; College
Glass Working Units for students and laboratory;
Photo-Flash Lamp Equipment; Neon Sign Manu-
facturing Equipment; Thermos Bottle Equipment;
Wire Butt Welders. CHAS. EISLER, Pres.

EISLER ENGINEERING COMPANY

739-750 So. 13th St. (Near Avon Ave.)

Newark, New Jersey.

PIEZO Electric Crystals Exclusively

• Quality crystals for all practical frequencies sup-
plied SINCE 1925. Prices quoted upon receipt
of your specifications.

Our Pledge: QUALITY FIRST

SCIENTIFIC RADIO SERVICE

UNIVERSITY PARK

HYATTSVILLE, MD.

AUDITORIUM SPEAKERS

Just announced by Jensen . . . a new line of 18-inch permanent magnet auditorium speakers. The manufacturer states that these new p-m speakers have efficiency equal in every respect to the field coil models of equal size. They are offered in four types to meet different response requirements. Jensen Model BR-18 Peri-dynamic enclosure is provided for all the new 18-inch speakers, thus four new models of Peri-dynamic reproducers with bass reflex are available, too. Complete descriptive literature available on request to the *Jensen Radio Manufacturing Co.*, 6601 S Laramie Ave., Chicago, Ill.—COMMUNICATIONS.

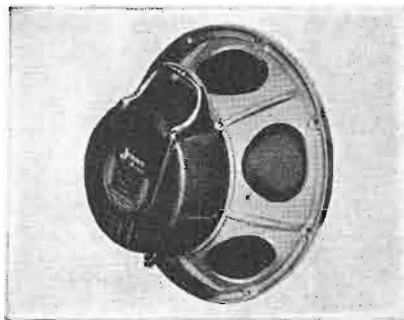

Above: Jensen speaker.

BAND SWITCH

The Type 892 band switch is designed for high-power transmitters up to one kw rating. It is simple and sturdy. Silver nickel contacts and a stainless steel spring eliminate poor contact due to corrosion. The ceramic is Alsimag 196 giving low dielectric loss and high insulating qualities. The index head is long wearing because moving parts are case hardened. Eddy current losses are low because dural spacers are used where intense fields are encountered. The band switch components are sold unassembled to provide the most flexible combinations for constructor's needs. The voltage between contacts is 5000; to ground, 4000. *Heintz & Kaufman, Ltd.*, S. San Francisco, Calif.—COMMUNICATIONS.

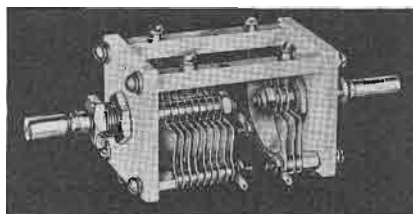

Below Cardwell condenser.

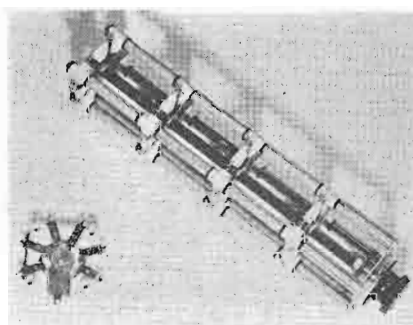

Above: Heintz & Kaufman band switch.

Below: Webster-Chicago phono motor.

PHONOGRAPH MOTORS

Webster-Chicago have just announced a new rim drive type of turntable motor, containing several new and interesting features. The motor operates at a relatively low speed, driving the turntable rim through a larger pulley, and as a consequence, the angle of velocity of the rim drive is said to be much lower. The manufacturers claim that this eliminates turntable vibration due to resonance. The only difference between 50 and 60-cycle motors of this type lies in the size of the driving wheel on the motor shaft. Requirements for 50-cycle equipment can be met by simply changing this wheel which can be done with a screw driver. Full information can be obtained from *Webster-Chicago*, 5622 Bloomingdale Ave., Chicago, Ill.—COMMUNICATIONS.

ALSIMAG 222

American Lava has recently put on the market a new ceramic material which carries the designation "Alsimag 222" and is a further addition to other well-known Alsimag ceramics. Alsimag 222 has the property that it can be machined after it has acquired strength by being fired. This makes it useful for inventors, research men, and development engineers who frequently have to build working models and do not want to go into the initial expense of costly dies for sample work. They can do their experimental work on machined insulators made of Alsimag 222 and, after having established the shape and size required, the final product can be substituted by another Alsimag material most suitable for the specific purpose. Alsimag 222 is supplied in round stock or in tubular form in various sizes up to 3" diameter, also in discs and plates up to 10" diameter. Special shapes can be cut to specifications upon request. *American Lava Corp.*, Chattanooga, Tenn.—COMMUNICATIONS.

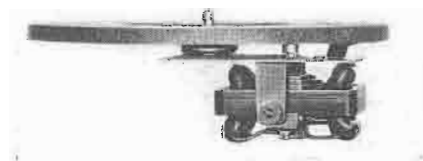

Above: Solar condenser—front and side sections.

Below: American Lava ceramic parts.

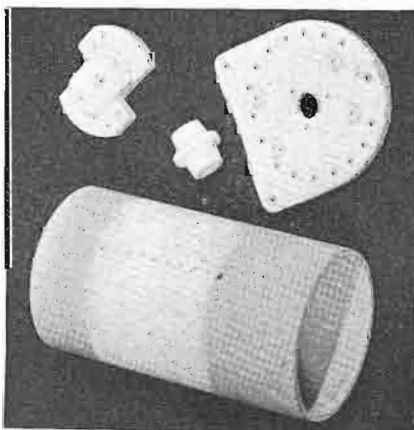

BAND-SPREAD CONDENSER

The new Cardwell types EU-25-100-AF and EU-50-100-AF band-spread condensers combine a low-capacity condenser for "band-spread" with a high capacity for "band-set"; both units in one compact trim-air midget frame. The high-capacity tank section may be locked at any desired capacity, allowing the tuning section to spread over a narrow band of frequencies over the entire dial for any band or inductor used. *The Allen D. Cardwell Mfg. Corp.*, 81 Prospect Street, Brooklyn, New York.—COMMUNICATIONS.

SOUND LEVEL METER

This new instrument has been designed to offer a convenient, portable means of measuring sound intensity in design and survey work. By means of a calibrated microphone and specially designed amplifier, all housed in a single portable carrying case, it is possible to measure the intensity of sounds or noises within the range of the human ear. The range of measurements is from plus 50 decibels to plus 125 decibels, in steps of one decibel each. A weighted response curve is employed, meeting the specifications set up by the American Acoustical Society. Complete information and bulletins describing the Pattern 15 Soundmaster may be secured by writing the manufacturer, *John Meck Instruments*, 164 N. May St., Chicago, Illinois.—COMMUNICATIONS.

SPEAKERS

Lansing has just placed on the market a new line of low-priced permanent-magnet and replacement speakers. Sizes from 5 to 15 inches are now available. All models are said to be mechanically heavy and rugged. Full information may be obtained by writing direct to *Lansing Mfg. Co.*, 6900 McKinley Ave., Los Angeles, Calif.—COMMUNICATIONS.

PAPER CONDENSERS

By a new method of manufacture, which embodies molding paper condenser sections in wax, Solar has developed a type of paper tubular bypass condenser which is said to show an indicated increase in probable life. In manufacturing these units, the cardboard tube has been dispensed with as a protection against moisture and the sections are molded directly in wax. A thin paper wrapper is used around the molded assembly to serve as a marker as well as a protection against mechanical abrasion. *Solar Manufacturing Corp.*, 599 Broadway, New York City.—COMMUNICATIONS.

BABY-BULL HORN

Latest product to be announced in the field of public-address equipment is known as the "baby-bull" horn—a powerful loudspeaker, made by Western Electric which is capable of radiating enjoyable music and high-quality speech to an open air audience of thousands. Because of its unique electro-acoustic characteristics and weather resistant construction the instrument is expected to find wide application as a sound reinforcement device in baseball parks, expositions, county fairs, outdoor concerts, and similar public gatherings where large masses of listeners are scattered over a broad area. *Western Electric Co.*, 195 Broadway, New York City.—COMMUNICATIONS.



No compensating adjustments while the condenser "warms up" when a Lapp gas-filled unit is on the job. Also: practically zero loss, small space requirement, puncture-proof. Available in wide range of sizes for replacement in existing circuits. Write for descriptive literature.

LAPP INSULATOR CO., INC.
LEROY, N. Y., U. S. A.

QUARTZ CRYSTALS

Piezo-Electric quartz blanks suitable for grinding to commercial frequencies.

Rough and semi-finished blanks to meet any commercial tolerances.

Quartz cut to any specifications.

Prices and information upon request.

G. C. HUNT and SONS
CARLISLE PENNSYLVANIA



SMOOTH ... QUIET ... DEPENDABLE

"PINCOR" offers the only complete line of "B" power supply equipment for police units, aircraft and radio broadcast service and sound systems. Frames, sizes and capacities to fit any requirement. "PINCOR" dynamotors are the last word in efficiency and regulation. Deliver high voltage current for proper operation of your apparatus with a minimum of A.C. ripple. Compact, light weight. With or without filter. Send for catalog.

PIONEER GEN-E-MOTOR CORPORATION
Dept. R-5G, 466 West Superior St., Chicago, Illinois



Without obligation kindly send me "PINCOR" Silver Band Dynamotor catalog and data sheets.

Name

Address

City..... State.....

Also send me Converter Catalog.

EIMAC TUBES

Three new Eimac tubes have recently been made available. These are the 75T, 1500T and 2000T. The 75T and the 2000T are shown in the accompanying illustration.

The 75T is a radiation-cooled triode designed to develop a high-power output while requiring low plate voltage. A new feature is a heat shield directly over the plate. The shield acts as a control to protect the plate lead seal. Tantalum elements are used. Interelectrode capacities are said to be low.

The Eimac 1500T must be cooled by a draft of air such as is provided by a fan or blower. Provision has been made so that the seals can be cooled by a draft of air as is provided by a small dental blower. Such cooling must be used on frequencies above 20 mc. On the lower frequencies a large radiator-connector having cooling fins similar to cylinder design for air-cooled gas engines will provide adequate seal cooling. A pair of 1500Ts operating as a class "C" modulated amplifier is suitable for 5 kw broadcast service. A pair operating in class "B" audio will supply the necessary audio power.

The Eimac 2000T must be cooled in same manner as 1500T. A pair of 2000Ts operating as a Class "C" modulated amplifier will supply 7.5 kw of antenna power for broadcast service. A pair of 2000T tubes operating in Class "B" audio will supply the necessary audio power for 100% modulation of the above carrier.

Eitel-McCullough, Inc., San Bruno, Calif.—COMMUNICATIONS.

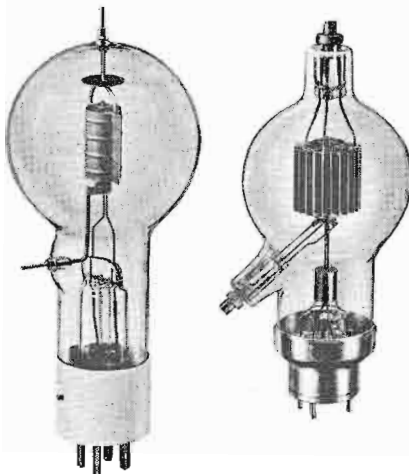

Above: Eimac tubes, 75T (left) & 2000T (right.)

Below: Pioneer converter.



TRANSCRIPTION PLAYBACK

A new portable professional transcription record player has been announced by Terminal. It weighs 32 pounds and is enclosed in a leather-reinforced carrying case. The unit operates on 110 volts, a-c or d-c. The motor has two speeds, 33 1/3 and 78 rpm. The turntable accommodates discs up to 17 1/4 inches. Descriptive literature is available from the Terminal Radio Corp., 68 W. 45th St., New York City.—COMMUNICATIONS.

SHALLCROSS BULLETIN

The Shallcross Current Flow Test Set No. 695 for relays is described in a new bulletin obtainable from the Shallcross Mfg. Co., 10 Jackson Ave., Collingdale, Pa. Considerable information is given.

CONVERTERS

A new line of rotary converters, designated as the Pincor "K" Series, was announced by Pioneer at the Radio Trade Show. The line consists of the following: Type "AK" 100 to 200 watts, Type "BK" 300 to 500 watts and Type "CK" 750 to 1000 watts, as well as units of greater capacities. These new converters feature all cast iron frames, built-in ventilators on four sides for dispensation of heat, etc. Available with filters for radio operation. Also made for constant speed phonograph work and similar uses. Pioneer also announced a new complete line of both motor generator sets and centrifugal pumps, in all sizes. Data on all these new "Pincor" products now available. Pioneer Gen-E-Motor Corp., 466 W. Superior St., Chicago, Ill.—COMMUNICATIONS.

Now..
5 VITAL FEATURES
 COMBINED IN
AMPERITE VELOCITY
 WITH ACOUSTIC COMPENSATOR

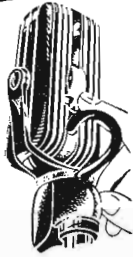

- it's a VELOCITY
- it's a DYNAMIC
- UNI-DIRECTIONAL
- NON-DIRECTIONAL
- HIGH OR LOW PITCH

UNI-DIRECTIONAL PICK-UP FIELD COMPENSATOR UP

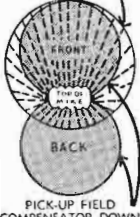

PICK-UP FIELD COMPENSATOR DOWN

By moving up the Acoustic Compensator, you change the Amperite Velocity Microphone to dynamic operation — without peaks. At the same time you reduce the back pickup, making the microphone practically UNI-DIRECTIONAL.

With the Acoustic Compensator down, the microphone is BI-DIRECTIONAL . . . 120 degrees front and back without frequency discrimination. Rotating the microphone until it parallels the ceiling makes

the microphone NON-DIRECTIONAL. THE ACOUSTIC COMPENSATOR is a regular feature of these models: RBHk (hi-imp); RBMk (200 ohms) LIST \$42.00. RSHk (hi-imp); RBSk (200 ohms) LIST \$32.00

Write for Complete Illustrated Bulletins and Valuable Sales Helps.

AMPERITE Co. 561 BROADWAY, N. Y. Cable Address: Alkem, New York

AMPERITE Velocity **MICROPHONES**

NEW! COMPLETE!



Free!

CORNELL-DUBILIER
 Radio Transmitter
 CAPACITOR CATALOG

NOW READY! Cornell-Dubilier's new 1939-40 catalog—featuring the most complete line of RADIO TRANSMITTER CAPACITORS in the world. It's brand new from cover to cover! Thirty-two pages of valuable information you'll want to have. Includes blue prints, charts, convenient break-down of capacitor features. Designed for quick, easy reference. Make this **FREE** book your guide to specifying capacitors. Handsomely bound. Write today for your copy of new C-D Catalog No. 160-T.

CORNELL-DUBILIER
ELECTRIC CORPORATION
 1005 Hamilton Boulevard, South Plainfield, New Jersey
 Cable Address: "CDBDU"

CORNELL-DUBILIER ELECTRIC CORPORATION, 1005 Hamilton Blvd., South Plainfield, N. J.

Rush copy of Catalog No. 160-T. Also put my name on your list for free copy of C-D House Organ.

Name
 Address
 City State

Index to Advertisers

A	
Aerovox Corp.	1
Amperex Electronic Products, Inc.	Inside Front Cover
Amperite Co.	40
B	
Bliley Electric Co.	37
Brush Development Co., The	27
C	
Callite Products Division	34
Cornell-Dubilier Elec. Corp.	40
D	
Daven Co., The	31
Driver Co., Wilbur B.	37
DuMont Laboratories, Inc., Allen B.	33
Duplex Recording Devices Co.	37
E	
Eisler Engineering Co.	37
Eitel-McCullough, Inc.	3
F	
Fairchild Aerial Camera Corp.	30
Ferris Instrument Corp.	33
Finch Telecommunications Labs., Inc.	28
G	
Gardiner Metal Co.	37
General Radio Co.	Inside Back Cover
Guardian Electric Co.	26
Guthman & Co., Inc., Edwin L.	37
H	
Holyoke Wire & Cable Corp.	16
Hunt & Sons, G. C.	39
J	
Jones, Howard B.	26
L	
Lansing Mfg. Co.	35
Lapp Insulator Co., Inc.	35
Lewis, Garrett W.	37
Lingo & Son, Inc., John E.	35
P	
Pioneer Genemotor Corp.	30
Presto Recording Corp.	29
R	
R. C. A. Communications, Inc.	26
R.C.A. Mfg. Co., Inc.	25, Back Cover
Radio Corporation of America	4
Recoton Corp.	34
S	
Scientific Radio Service	37
Shallcross Mfg. Co.	30
South Bend Microphone Co.	34
T	
Taylor Fibre Co.	37
Thomas & Skinner Steel Products Co.	35
W	
Wholesale Radio Service Co., Inc.	40
Z	
Zophar Mills, Inc.	23

We hobnob with BIG SHOTS



You are known by the company you keep. Which must account for our world-wide reputation. For in our stock of over 50,000 radio items are the finest names in the industry. It's not that we're social climbers. We hobnob with leading manufacturers because we believe in giving our customers what they want—at prices they like to pay. We find it pays all around. Send for our new **FREE** catalog.

WHOLESALE RADIO SERVICE CO. INC.
 100 SIXTH AVE., NEW YORK, N. Y.
 CHICAGO, ILL. • ATLANTA, GA. • BOSTON, MASS.
 BRONX, N. Y. • NEWARK, N. J. • JAMAICA, L. I.

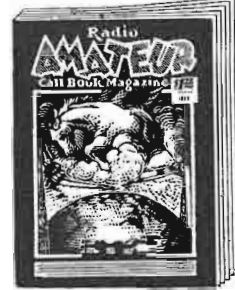

Radio Engineers

who are
RADIO AMATEURS
 buy a fresh copy today of the
RADIO AMATEUR CALL BOOK

The CALLBOOK is the only publication that lists all licensed radio amateurs in the United States and over a hundred and seventy-five different foreign countries.

Each issue also contains a world map showing amateur prefixes, press time and weather schedules, amateur prefixes listed alphabetically and by countries and a world time conversion chart.

Complete . . . Accurate . . . Up-to-Date

Issued Quarterly
MARCH . . . JUNE . . . SEPTEMBER
 and **DECEMBER**

Annual subscription \$4.00
 Single copies \$1.25

Buy your copy now from your radio jobber or direct from:

Radio Amateur Call Book, Inc.
 608 S. Dearborn St., Chicago, Ill., U. S. A.

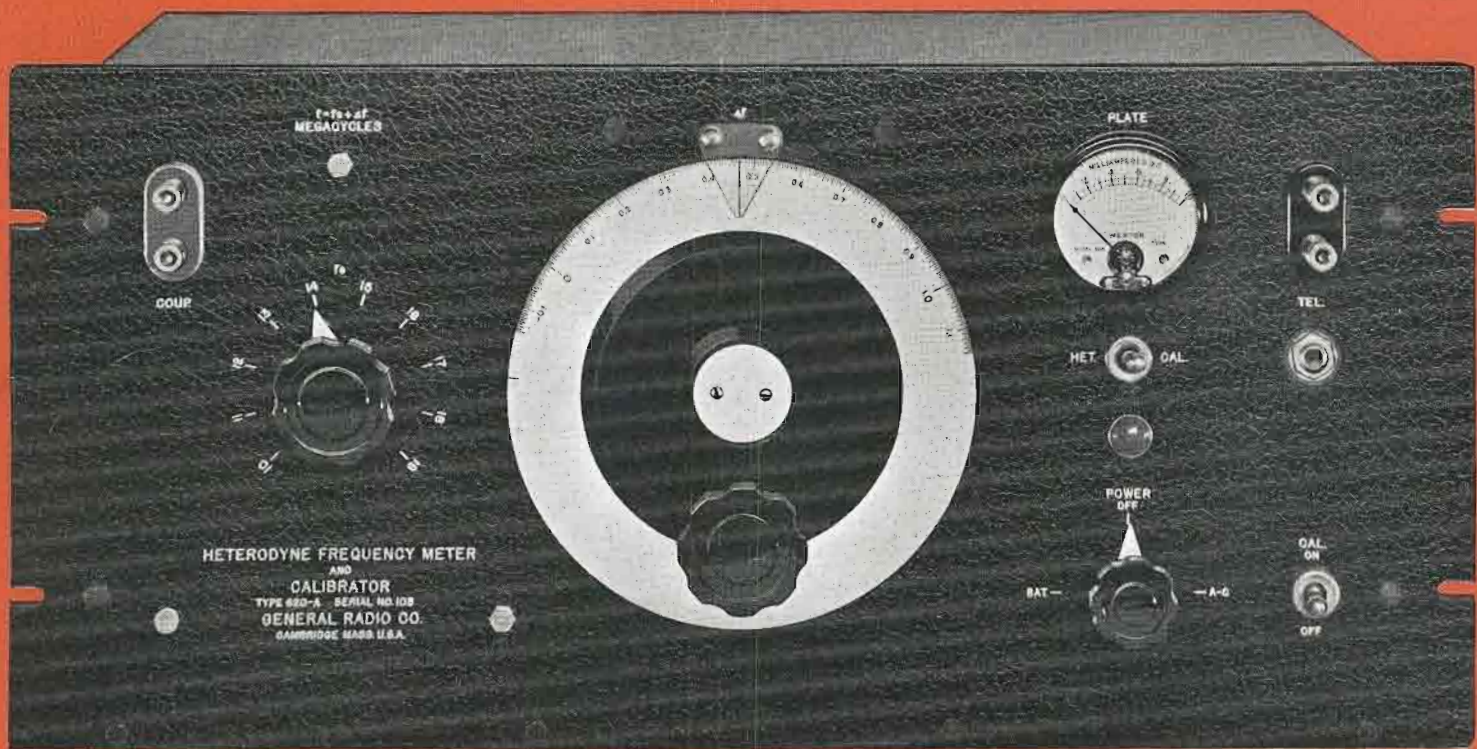

for Television

and other Ultra-High-Frequency Services

ACCURATE • SIMPLE TO OPERATE • WIDE FREQUENCY RANGE

THE GENERAL RADIO Type 620-A Heterodyne Frequency Meter and Calibrator offers a number of advantages for frequency measurements and monitoring in the high- and ultra-high-frequency bands. Its accuracy is sufficient for use as a monitor for television transmitters; its direct-reading feature is a great convenience in laboratory and production testing of television receivers.

- **HIGH UPPER-FREQUENCY LIMIT**—satisfactory to 300 Mc
- **VERY WIDE RANGE**—300 kc to 300 Mc
- **DIRECT READING**—no charts or curves
- **SELF-CALIBRATING**—calibration can be checked instantly from built-in piezo-electric oscillator
- **NO COILS TO CHANGE**—built-in coil system with 10-point panel selector switch
- **GOOD ACCURACY**—over-all accuracy 0.01% or better, in terms of crystal calibrator—can be used as transmitter frequency monitor if allowable tolerance is 0.02% or greater
- **FLEXIBLE POWER SUPPLY**—built-in a-c operated supply or external d-c source, either selected by panel switch

TYPE 620-AR Relay Rack Model..... \$490.00
 TYPE 620-AM Portable Model \$555.00

• WRITE FOR BULLETIN 455 FOR COMPLETE DATA

GENERAL RADIO COMPANY CAMBRIDGE MASSACHUSETTS



Stability PLUS Dependability
ON DIRECT OPERATION
from a Phototube

One Tube
DOES THE WORK
OF TWO



... With the New RCA
HOT-CATHODE GAS TETRODES

Having extreme sensitivity and outstanding stability over a wide range of anode voltage, the new RCA-2050 and RCA-2051 gas-filled tetrode tubes of the indirectly heated, hot-cathode type, pave the way for important savings in grid-controlled rectifier and relay applications. They are particularly adapted for use in control devices actuated either by phototubes or radio signals.

Grid current is extremely low, permitting high grid resistance to be used in the grid circuit. The resulting high sensitivity permits the tube to be operated directly by a vacuum-type phototube, as shown in Diagram No. 1, thus eliminating one or more tubes previously required in conventional circuits (Diagram No. 2).

The control characteristic is very steep, having a control ratio of approximately 325. Only low values of grid-bias voltage are required. A very small grid-anode capacitance makes the tubes insensitive to line voltage surges and minimizes the undesirable effect of capacitance current flowing through the grid resistance.

Now ready for delivery, the tubes are detailed in an engineering folder available from RCA Commercial Engineering Section, Harrison, N. J.

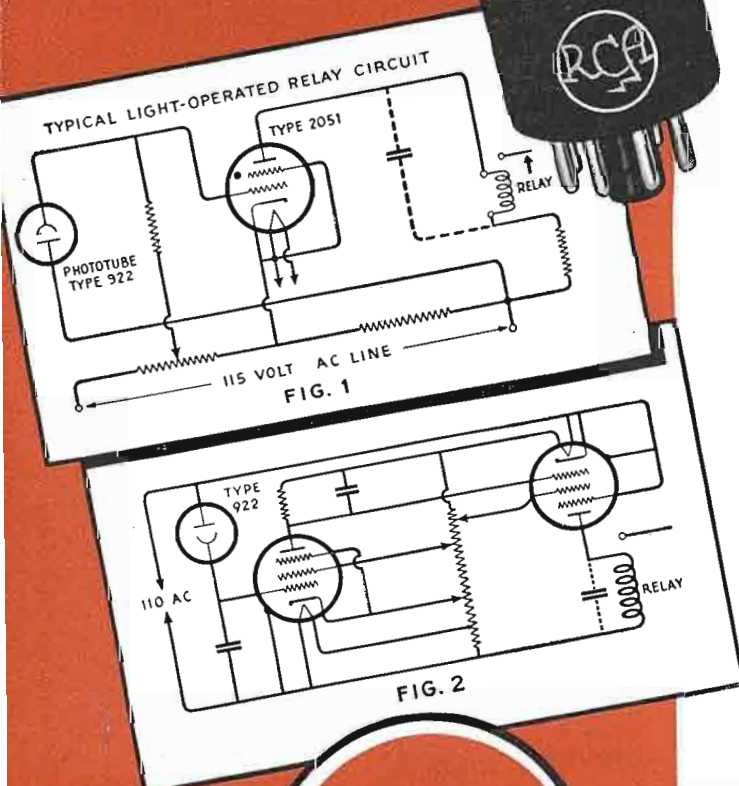

RCA-2050—Used to control up to 650 volts peak and will handle a peak current of 500 ma. and an average current of 100 ma.

RCA-2051—Used to control up to 350 volts peak and will handle a peak current of 375 ma. and an average current of 75 ma.

The above illustration of RCA-2050 is approximately actual size. Each tube has small, ST-12 bulb, uses standard octal base and is of extremely rugged construction.

CHARACTERISTICS

	Type 2050	Type 2051
HEATER VOLTAGE	6.3	6.3 Volts
HEATER CURRENT	0.6	0.6 Amperes
PEAK ANODE VOLTAGE (Max.)	650	350 Volts
PEAK ANODE CURRENT (Max.)	500	375 Ma.
AVERAGE ANODE CURRENT (Max.)	100	75 Ma.
GRID RESISTOR (Max.)	10	10 Megohms

Visit RCA Television Exhibits at Golden Gate International Exposition and New York World's Fair.



Radio Tubes