



Application Note

AN-183

Applications of the RCA-7199 Triode-Pentode in High-Fidelity Audio Equipment

This Note describes the special features of the RCA-7199 triode-pentode, and discusses its application in "hi-fi" audio equipment. The RCA-7199 is a 9-pin miniature type containing a medium-mu triode and a sharp-cutoff high-transconductance pentode, and having very low hum, leakage noise, and microphonism. It is specially designed and controlled for use in high-fidelity audio equipment in stages operating at signal levels in the order of 100 millivolts. It is particularly useful in direct-coupled voltage-amplifier phase-splitter circuits, and in tone-control circuits.

The Note gives two circuits in which the RCA-7199 is used as a direct-coupled voltage amplifier and phase splitter, and one in which the pentode unit of the tube is used as a general-purpose voltage amplifier. It also discusses the advantages to be gained by operation of voltage-amplifier pentodes at low plate and grid-No 2 voltages, and gives graphs and calculations showing how these advantages may be achieved for the pentode unit of the RCA-7199.

Design Features and Characteristics

The RCA-7199 utilizes a specially designed cage assembly and stem which make it much less susceptible than other triode-pentodes to microphonics. These features also provide a rugged tube structure and minimize leakage noise. The heaters of the two units are specially designed to produce very low magnetic hum. Median values of hum and noise, expressed as equivalent voltages at the control grids, are 35 microvolts for the pentode unit and 10 microvolts for the triode unit. Maximum values are 100 microvolts for the pentode unit and 150 microvolts for the triode unit. These equivalent hum-and-noise voltages are for grid-circuit resistances of 50,000 ohms.

Because of its high transconductance (7000 μmhos), the pentode unit of the 7199 can provide large voltage gains (values of 100 to 350 are typical). It can also deliver output signals as large as 90 volts peak-to-peak with low distortion. The triode unit has a mu of 17 and can



handle large signal voltages. This combination of characteristics, together with its very low hum and noise, makes the 7199 especially suitable for use as a voltage amplifier and cathode follower, or a voltage amplifier and phase splitter (the phase splitter is a form of cathode follower).

Hum and Noise Performance

The hum-and-noise performance that can be expected from the 7199 when precautions are taken in circuit layout and wiring to eliminate hum and noise from other sources is illustrated by the following example:

Assume that the pentode unit of the 7199 is to be used in the input stage of an amplifier having a sensitivity of 100 millivolts RMS. (The rated power output or voltage output of the amplifier need not be specified). The amplifier has an input resistance of 50,000 ohms. Based on the maximum value of hum and noise for the pentode unit (100 microvolts), the minimum signal-to-noise ratio at the amplifier input in decibels will be

$$20 \log \frac{0.1}{0.0001} = 20 \log 1,000, \text{ or } 60 \text{ db.}$$

Based on the median value of hum and noise for the pentode unit (35 microvolts), this ratio will be

$$20 \log \frac{0.1}{0.000035} = 20 \log 2,850, \text{ or approximately } 69 \text{ db.}$$

If the input stage has a gain of at least 20 db (a voltage gain of 10), hum and noise originating in the grid circuits of succeeding stages can be neglected, and the signal-to-noise ratio at the amplifier output will be the same as that at the input. Because the pentode unit of the 7199 can easily provide voltage gains of more than 100, these conditions are easily realized. Hum and noise at the output of the amplifier, therefore, will be at least 60 db below rated output.

It is evident from the foregoing example that if the pentode unit of the RCA-7199 is used in the input stage of a preamplifier, or in any other application where the input signal level is only a few millivolts, the hum and noise at the output of the following amplifier may be substantially less than 60 db below rated output. For high-fidelity reproduction, therefore, the pentode unit of the 7199 should not be used in any stage where the input signal level is substantially less than 100 millivolts.

Applications

An example of the use of the 7199 as a voltage amplifier and phase splitter is shown in Fig. 1. In this high-fidelity, 15-watt, power amplifier, the pentode unit of the 7199 is direct-coupled to the triode unit, which drives a pair of RCA-6973 high-fidelity beam power tubes operating in class AB₁ with fixed bias. The amplifier uses 18 db of degenerative

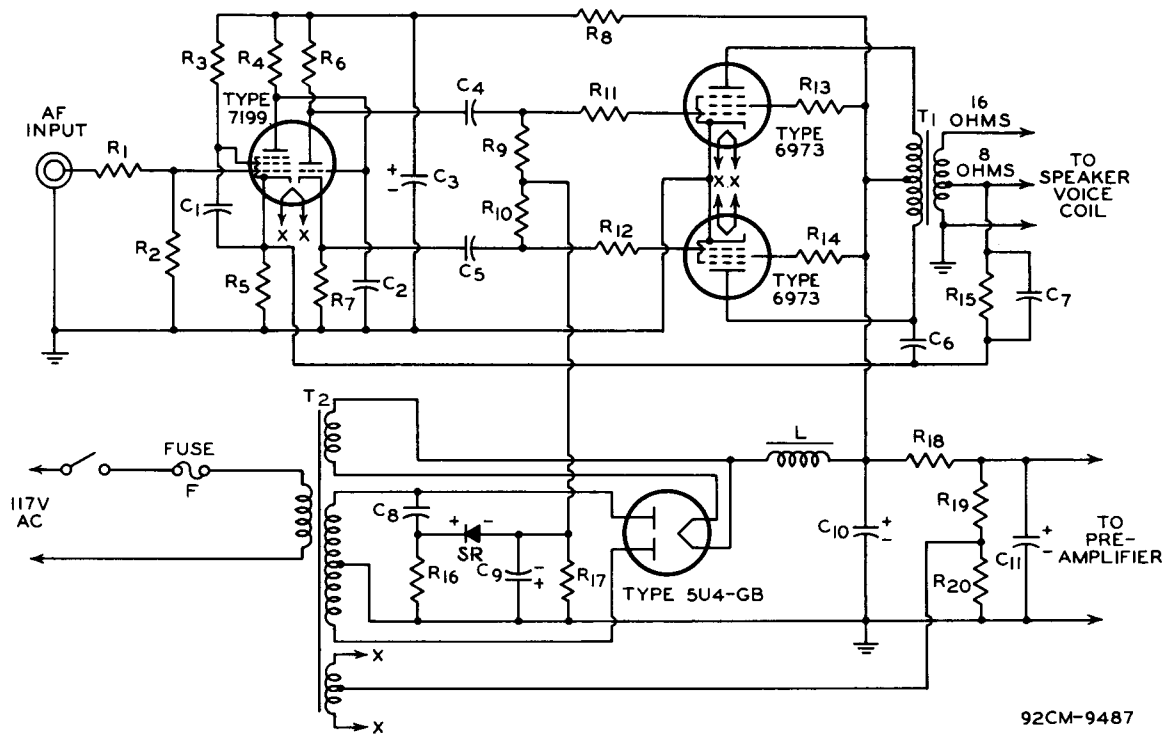

92CM-9487

- | | |
|---|---|
| C ₁ : 0.25 μ f, 600 v., paper | R ₆ , R ₇ : 15,000 ohms \pm 5%, 2 watts |
| C ₂ : 3.3 μ f, 400 v., mica or ceramic | R ₈ : 3900 ohms, 2 watts |
| C ₃ , C ₁₁ : 40 μ f, 450 v., electrolytic | R ₉ , R ₁₀ : 100,000 ohms, 0.5 watt |
| C ₄ , C ₅ : 0.25 μ f, 600 v., paper | R ₁₁ , R ₁₂ : 1000 ohms, 0.5 watt |
| C ₆ : 3.3 μ f, 600 v., mica or ceramic | R ₁₃ , R ₁₄ : 100 ohms, 0.5 watt |
| C ₇ : 150 μ f, 400 v., mica or ceramic | R ₁₅ : 8200 ohms, 0.5 watt |
| C ₈ : 0.02 μ f, 600 v., paper | R ₁₆ : 15,000 ohms, 1 watt |
| C ₉ : 100 μ f, 50 v., elec- trolytic | R ₁₇ : 68,000 ohms, 0.5 watt |
| C ₁₀ : 80 μ f, 450 v., elec- trolytic | R ₁₈ : 4700 ohms, 2 watts |
| F: Fuse, 3 amperes, 150 volts | R ₁₉ : 270,000 ohms, 1 watt |
| L: Filter choke, 3 henries, 160 ma., 75 ohms, Triad type C13X or equivalent | R ₂₀ : 47,000 ohms, 0.5 watt |
| R ₁ : 10,000 ohms, 0.5 watt | SR: Selenium rectifier, 20 ma., 135 volts rms |
| R ₂ : 470,000 ohms, 0.5 watt | T ₁ : Output transformer for matching speaker voice- coil impedance to 6600- ohm plate-to-plate tube load, Stancor type A8056 or equivalent |
| R ₃ : 820,000 ohms, 0.5 watt | T ₂ : Power transformer, 360-0- 360 volts rms, 120 ma., Stancor type PC 8410 or equivalent |
| R ₄ : 220,000 ohms, 0.5 watt | |
| R ₅ : 820 ohms, 0.5 watt | |

Fig.1 - High-fidelity power amplifier using the RCA-7199 triode-pentode as a high-gain voltage amplifier and phase splitter.



feedback between the voice-coil connection and the voltage-amplifier cathode. At 15 watts output, total harmonic distortion (measured at 1000 cps) is less than 0.5 per cent, and intermodulation distortion is less than 0.5 per cent. Hum and noise with input shorted are 84 db below rated output. As shown in Fig.2, the frequency response of the amplifier at 4 watts output is flat over the entire audio spectrum and down less than 2 db at 10 cps and 60,000 cps. At 15 watts output, the frequency response is flat from 20 cps to 15,000 cps, and down less than 1 db at 15 cps and 20,000 cps. The amplifier has a sensitivity of 1.2 volts RMS, and a damping factor of 12.

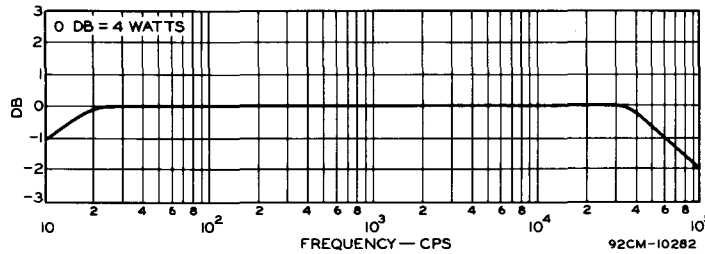

Fig.2 - Frequency-response characteristics of the amplifier shown in Fig.1.

A slightly different voltage-amplifier/phase-splitter circuit which also is capable of very good performance is shown in Fig.3. In this circuit, grid-No.2 voltage for the pentode unit of 7199 is obtained through

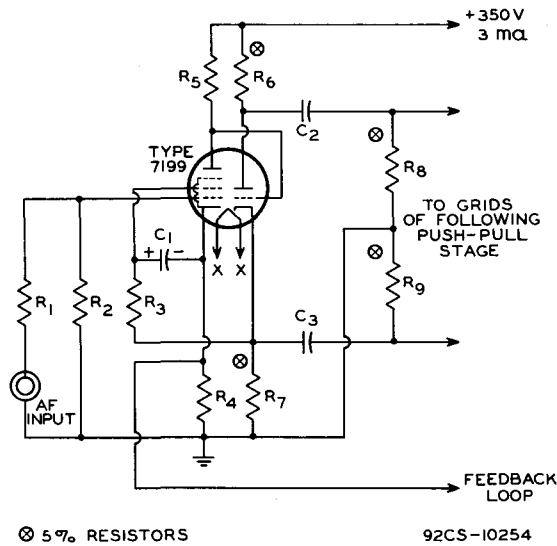

Fig.3 - Voltage-amplifier/phase-splitter circuit using the RCA-7199.

a 220,000-ohm resistor from the cathode of the triode unit. This arrangement provides regenerative feedback between the two units which can be used to obtain increased over-all gain at the lower audio frequencies.



The frequency at which this feedback becomes effective depends on the value of the grid-No.2 bypass capacitor C_1 . If C_1 has a small value, it may be necessary to use relatively heavy filtering in the B supply circuit to prevent motorboating.

The voltage-amplifier/phase-splitter circuits shown in Figs. 1 and 2 produce extremely low harmonic distortion, have frequency-response characteristics extending well beyond the audio range, and permit the use of relatively large amounts of over-all feedback. The phase-splitter stages are easily balanced at low frequencies by adjustment of the plate and cathode resistors, and have input impedances of several megohms, thus making it possible to achieve very high gains in the pentode stages.

Some of the special considerations involved in the use of such circuits are:

(1) As the plate-load resistance for the pentode unit is increased, the distortion produced by this unit increases more rapidly than its gain;

(2) If the plate-supply voltage is low, the use of direct coupling between the pentode and triode units may result in undesirably low plate voltage for the pentode unit;

(3) To obtain equal response at the higher audio frequencies in the two output circuits of the phase splitter, it may be necessary to equalize the capacitances to ground of the plate and cathode of the triode unit.

Operation of Voltage-Amplifier Pentodes at Low Plate and Grid-No 2 Voltages

There are two methods by which a pentode may be operated so as to produce low harmonic distortion. One is to operate the pentode over the most nearly linear region of its characteristic. The other is to select an operating point just above the "knee" of the characteristic, so that second-harmonic distortion is partially cancelled by third-harmonic distortion. Although the latter method provides the highest gain, and has recently been used by some circuit designers for that reason, it is not recommended for production equipment because of the initial adjustment required. Normal variations among pentodes of the same type are such that a quiescent point which is just above the "knee" for one tube may be on or under the "knee" for another, and thus result in low gain and very high distortion.

Although operation over the most nearly linear region of the characteristic provides less gain, it provides much more latitude for normal variations in tube characteristics, and, therefore, is the recommended method of operation for pentodes. To achieve maximum latitude in this method of operation, it is necessary to take into consideration the effects on harmonic distortion of normal variations in transconductance, plate resistance, amplification factor, cathode current, and plate-to-grid-No. 2 current ratio.



Fig. 4 shows the total harmonic distortion and voltage gain of the pentode unit of the RCA-7199 as a function of plate-load resistance. The three distortion curves show the spread of this characteristic for tubes having high, average, and low plate currents; gain curve is for typical tube having average plate current.

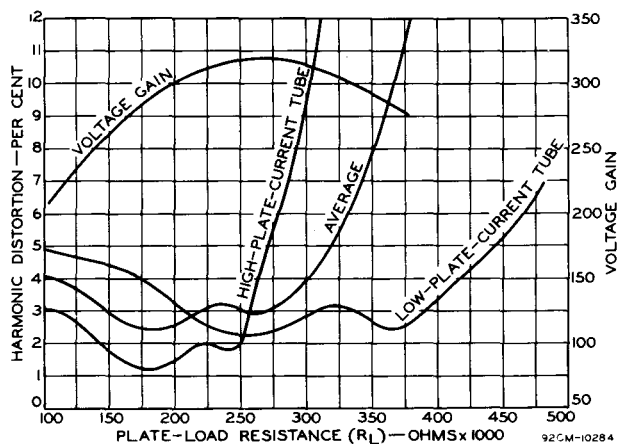

Fig. 4 - Total harmonic distortion and voltage gain of the pentode unit of an RCA-7199 as a function of plate-load resistance. Distortion curves are for typical tubes having high, average, and low plate currents; gain curve is for typical tube having average plate current.

having high, low, and average values of plate current. This figure also shows the voltage gain of a tube having average plate current as a function of plate-load resistance.

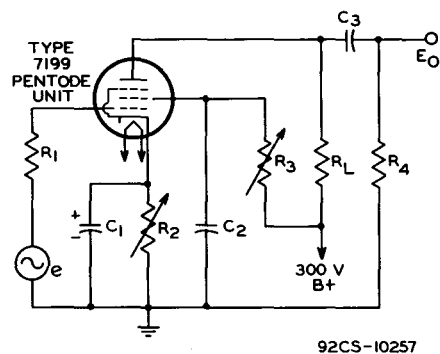

Fig. 5 - Amplifier circuit used to obtain data shown in Fig. 4. Cathode resistor was adjusted to provide grid-No. 1 bias of -1 volt.

These curves were obtained with the tubes operated in the circuit shown in Fig. 5, using a constant signal-input voltage of 0.1 volt (100 millivolts) RMS, and with the cathode resistor adjusted to provide a grid-



No.1 bias of -1 volt. The average maximum output voltage obtained in this circuit was 32 volts RMS (representing a gain of 320), or 90 volts peak-to-peak, which is sufficient to drive the largest audio-output tubes.

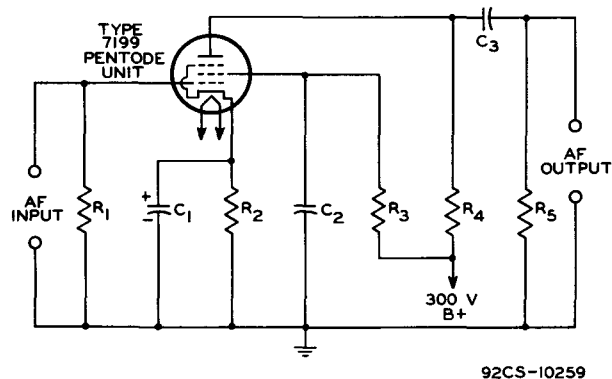

Fig. 6 - General-purpose voltage-amplifier circuit using the pentode unit of an RCA-7199.

The first minimum point on each distortion curve is that obtained by operation over the most nearly linear region of the tube characteristic. The second minimum point is for operation in the knee region, which is not recommended.

It is evident from Fig. 4 that the optimum value of plate-load resistance under the conditions employed is between 180,000 and 240,000 ohms. (The average value of cathode resistance required to provide -1 volt of bias for this range of plate-load resistance values was 750 ohms). The

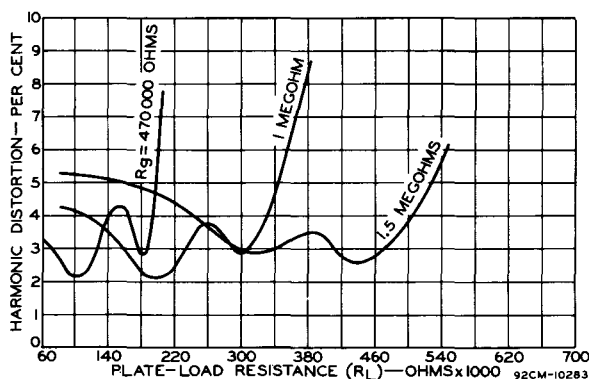

Fig. 7 - Total harmonic distortion of a typical RCA-7199 pentode unit as a function of plate-load resistance and grid-No. 2 resistance.

circuit of a general-purpose amplifier stage using the pentode unit of the 7199 with the recommended component values is shown in Fig. 6. In this circuit, the average grid-No. 2 voltage of the pentode is 35 volts.



The spread of a typical curve of distortion vs plate-load resistance, such as the curve for an average pentode shown in Fig. 4, can be broadened so as to make circuit performance less critical with respect to individual tube characteristics and component values by an increase in the value of the grid-No.2 resistor. Fig. 7 shows the distortion of a typical 7199 pentode unit as a function of grid-No.2 resistance and plate-load resistance. These data were obtained in the circuit shown in Fig. 8.

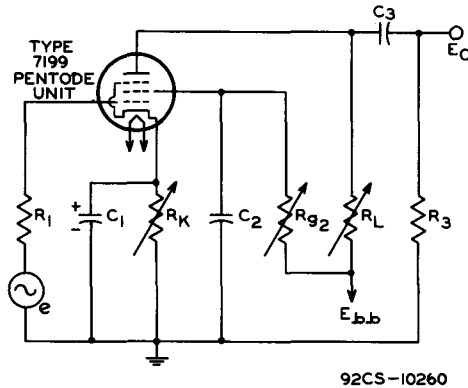

Fig. 8 - Amplifier circuit used to obtain data shown in Fig. 7.

It is evident that as the grid-No.2 resistance is made larger--i.e., as the grid-No.2 voltage is reduced--the plate-load resistance for minimum distortion increases and becomes much less critical. This effect can be used to advantage in the design of direct-coupled pentode-triode circuits such as those shown in Figs. 1 and 3. In such circuits, the pentode unit must be operated at low plate voltage to provide proper bias for the triode unit, and, therefore, must also be operated with low grid-No.2 voltage. The use of high-value plate-load and grid-No.2 resistors of relatively wide tolerance satisfies these requirements, minimizes the sensitivity of the circuit to variations in tube characteristics and component values, and reduces manufacturing costs.

The curves in Fig. 7 also indicate that in any pentode amplifier application it is possible to achieve minimum distortion for any value of plate-load resistance by adjustment of the grid-No.2 resistance. This feature makes it possible to optimize gain and distortion for any desired high-frequency "roll-off" characteristic.

Information furnished by RCA is believed to be accurate and reliable. However, no responsibility is assumed by RCA for its use; nor for any infringements of patents or other rights of third parties which may result from its use. No license is granted by implication or otherwise under any patent or patent rights of RCA.